

# STRUCTURAL CONCRETE

THEORY AND DESIGN **SIXTH EDITION**



M. NADIM HASSOUN, AKTHEM AL-MANASEER

WILEY



# Structural Concrete



# Structural Concrete

Theory and Design

*Sixth Edition*

M. Nadim Hassoun

South Dakota State University

Akthem Al-Manaseer

San Jose State University

WILEY

Portions of this publication reproduce excerpts from the *2012 International Building Code*, International Code Council, Inc., Washington, D.C. Reproduced by permission. All rights reserved. [www.iccsafe.org](http://www.iccsafe.org)

This book is printed on acid-free paper.

Copyright © 2015 by John Wiley & Sons, Inc. All rights reserved.

Published by John Wiley & Sons, Inc., Hoboken, New Jersey.  
Published simultaneously in Canada.

No part of this publication may be reproduced, stored in a retrieval system, or transmitted in any form or by any means, electronic, mechanical, photocopying, recording, scanning, or otherwise, except as permitted under Section 107 or 108 of the 1976 United States Copyright Act, without either the prior written permission of the Publisher, or authorization through payment of the appropriate per-copy fee to the Copyright Clearance Center, Inc., 222 Rosewood Drive, Danvers, MA 01923, 978-750-8400, fax 978-646-8600, or on the web at [www.copyright.com](http://www.copyright.com). Requests to the Publisher for permission should be addressed to the Permissions Department, John Wiley & Sons, Inc., 111 River Street, Hoboken, NJ 07030, 201-748-6011, fax 201-748-6008, or online at <http://www.wiley.com/go/permissions>.

**Limit of Liability/Disclaimer of Warranty:** While the publisher and author have used their best efforts in preparing this book, they make no representations or warranties with respect to the accuracy or completeness of the contents of this book and specifically disclaim any implied warranties of merchantability or fitness for a particular purpose. No warranty may be created or extended by sales representatives or written sales materials. The advice and strategies contained herein may not be suitable for your situation. You should consult with a professional where appropriate. Neither the publisher nor the author shall be liable for damages arising herefrom.

For general information on our other products and services, or technical support, please contact our Customer Care Department within the United States at 800-762-2974, outside the United States at 317-572-3993 or fax 317-572-4002.

Wiley publishes in a variety of print and electronic formats and by print-on-demand. Some material included with standard print versions of this book may not be included in e-books or in print-on-demand. If this book refers to media such as a CD or DVD that is not included in the version you purchased, you may download this material at <http://booksupport.wiley.com>. For more information about Wiley products, visit [www.wiley.com](http://www.wiley.com).

***Library of Congress Cataloging-in-Publication Data:***

Hassoun, M. Nadim.

Structural concrete : theory and design / M. Nadim Hassoun, South Dakota State University; Akthem Al-Manaseer, San Jose State University. – Sixth edition.

pages cm

Includes index.

ISBN 978-1-118-76781-8 (hardback) – 978-1-118-76813-6 (epdf) – 978-1-118-76778-8 (epub)

1. Reinforced concrete construction. 2. Buildings, Reinforced concrete. I. Al-Manaseer, A. A. (Akthem A.) II. Title.

TA683.2.H365 2015

624.1'8341–dc23

2014041923

Printed in the United States of America

10 9 8 7 6 5 4 3 2 1

# CONTENTS

Preface	xiii
Notation	xvii
Conversion Factors	xxiii
1 Introduction	1
1.1 Structural Concrete	1
1.2 Historical Background	1
1.3 Advantages and Disadvantages of Reinforced Concrete	3
1.4 Codes of Practice	4
1.5 Design Philosophy and Concepts	4
1.6 Units of Measurement	5
1.7 Loads	6
1.8 Safety Provisions	8
1.9 Structural Concrete Elements	9
1.10 Structural Concrete Design	9
1.11 Accuracy of Calculations	10
1.12 Concrete High-Rise Buildings	10
References	13
2 Properties of Reinforced Concrete	15
2.1 Factors Affecting Strength of Concrete	15
2.2 Compressive Strength	17
2.3 Stress–Strain Curves of Concrete	18
2.4 Tensile Strength of Concrete	19
2.5 Flexural Strength (Modulus of Rupture) of Concrete	21
2.6 Shear Strength	21
2.7 Modulus of Elasticity of Concrete	22
2.8 Poisson’s Ratio	23

2.9	Shear Modulus	24	
2.10	Modular Ratio	24	
2.11	Volume Changes of Concrete	24	
2.12	Creep	25	
2.13	Models for Predicting Shrinkage and Creep of Concrete	27	
2.14	Unit Weight of Concrete	69	
2.15	Fire Resistance	70	
2.16	High-Performance Concrete	70	
2.17	Lightweight Concrete	71	
2.18	Fibrous Concrete	72	
2.19	Steel Reinforcement	72	
	Summary	78	
	References	79	
	Problems	80	
<b>3</b>	<b>Flexural Analysis of Reinforced Concrete Beams</b>		<b>83</b>
3.1	Introduction	83	
3.2	Assumptions	84	
3.3	Behavior of Simply Supported Reinforced Concrete Beam Loaded to Failure	84	
3.4	Types of Flexural Failure and Strain Limits	88	
3.5	Load Factors	91	
3.6	Strength Reduction Factor $\phi$	93	
3.7	Significance of Analysis and Design Expressions	94	
3.8	Equivalent Compressive Stress Distribution	94	
3.9	Singly Reinforced Rectangular Section in Bending	99	
3.10	Lower Limit or Minimum Percentage of Steel	108	
3.11	Adequacy of Sections	109	
3.12	Bundled Bars	113	
3.13	Sections in the Transition Region ( $\phi < 0.9$ )	114	
3.14	Rectangular Sections with Compression Reinforcement	116	
3.15	Analysis of T- and I-Sections	127	
3.16	Dimensions of Isolated T-Shaped Sections	136	
3.17	Inverted L-Shaped Sections	137	
3.18	Sections of Other Shapes	137	
3.19	Analysis of Sections Using Tables	139	
3.20	Additional Examples	140	
3.21	Examples Using SI Units	142	
	Summary	145	
	References	148	
	Problems	148	
<b>4</b>	<b>Flexural Design of Reinforced Concrete Beams</b>		<b>152</b>
4.1	Introduction	152	
4.2	Rectangular Sections with Tension Reinforcement Only	152	
4.3	Spacing of Reinforcement and Concrete Cover	155	
4.4	Rectangular Sections with Compression Reinforcement	162	



4.5	Design of T-Sections	169	
4.6	Additional Examples	174	
4.7	Examples Using SI Units	178	
	Summary	181	
	Problems	184	
5	Shear and Diagonal Tension		188
5.1	Introduction	188	
5.2	Shear Stresses in Concrete Beams	188	
5.3	Behavior of Beams without Shear Reinforcement	191	
5.4	Moment Effect on Shear Strength	193	
5.5	Beams with Shear Reinforcement	195	
5.6	ACI Code Shear Design Requirements	198	
5.7	Design of Vertical Stirrups	201	
5.8	Design Summary	205	
5.9	Shear Force Due to Live Loads	209	
5.10	Shear Stresses in Members of Variable Depth	213	
5.11	Examples Using SI Units	217	
	Summary	222	
	References	222	
	Problems	223	
6	Deflection and Control of Cracking		226
6.1	Deflection of Structural Concrete Members	226	
6.2	Instantaneous Deflection	227	
6.3	Long-Time Deflection	233	
6.4	Allowable Deflection	234	
6.5	Deflection Due to Combinations of Loads	234	
6.6	Cracks in Flexural Members	243	
6.7	ACI Code Requirements	247	
	Summary	252	
	References	253	
	Problems	254	
7	Development Length of Reinforcing Bars		257
7.1	Introduction	257	
7.2	Development of Bond Stresses	258	
7.3	Development Length in Tension	261	
7.4	Development Length in Compression	264	
7.5	Summary for Computation of $l_d$ in Tension	266	
7.6	Critical Sections in Flexural Members	268	
7.7	Standard Hooks (ACI Code, Sections 25.3 and 25.4)	272	
7.8	Splices of Reinforcement	276	
7.9	Moment–Resistance Diagram (Bar Cutoff Points)	281	
	Summary	285	
	References	286	
	Problems	287	

8	Design of Deep Beams by the Strut-and-Tie Method	290
8.1	Introduction	290
8.2	B- and D-Regions	290
8.3	Strut-and-Tie Model	290
8.4	ACI Design Procedure to Build a Strut-and-Tie Model	293
8.5	Strut-and-Tie Method According to AASHTO LRFD	301
8.6	Deep Members	303
	References	321
	Problems	321
9	One-Way Slabs	324
9.1	Types of Slabs	324
9.2	Design of One-Way Solid Slabs	326
9.3	Design Limitations According to ACI Code	328
9.4	Temperature and Shrinkage Reinforcement	328
9.5	Reinforcement Details	329
9.6	Distribution of Loads from One-Way Slabs to Supporting Beams	329
9.7	One-Way Joist Floor System	335
	Summary	338
	References	339
	Problems	340
10	Axially Loaded Columns	342
10.1	Introduction	342
10.2	Types of Columns	342
10.3	Behavior of Axially Loaded Columns	344
10.4	ACI Code Limitations	344
10.5	Spiral Reinforcement	347
10.6	Design Equations	348
10.7	Axial Tension	349
10.8	Long Columns	349
	Summary	352
	References	353
	Problems	354
11	Members in Compression and Bending	356
11.1	Introduction	356
11.2	Design Assumptions for Columns	358
11.3	Load–Moment Interaction Diagram	358
11.4	Safety Provisions	361
11.5	Balanced Condition: Rectangular Sections	362
11.6	Column Sections under Eccentric Loading	365
11.7	Strength of Columns for Tension Failure	367
11.8	Strength of Columns for Compression Failure	370
11.9	Interaction Diagram Example	376
11.10	Rectangular Columns with Side Bars	377
11.11	Load Capacity of Circular Columns	381
11.12	Analysis and Design of Columns Using Charts	386

11.13	Design of Columns under Eccentric Loading	391
11.14	Biaxial Bending	397
11.15	Circular Columns with Uniform Reinforcement under Biaxial Bending	399
11.16	Square and Rectangular Columns under Biaxial Bending	402
11.17	Parame Load Contour Method	403
11.18	Equation of Failure Surface	408
11.19	SI Example	411
	Summary	413
	References	415
	Problems	415
12	Slender Columns	420
12.1	Introduction	420
12.2	Effective Column Length ( $Kl_u$ )	421
12.3	Effective Length Factor ( $K$ )	422
12.4	Member Stiffness ( $EI$ )	425
12.5	Limitation of the Slenderness Ratio ( $Kl_u/r$ )	427
12.6	Moment-Magnifier Design Method	428
	Summary	438
	References	440
	Problems	441
13	Footings	443
13.1	Introduction	443
13.2	Types of Footings	445
13.3	Distribution of Soil Pressure	448
13.4	Design Considerations	449
13.5	Plain Concrete Footings	459
13.6	Combined Footings	472
13.7	Footings under Eccentric Column Loads	478
13.8	Footings under Biaxial Moment	479
13.9	Slabs on Ground	483
13.10	Footings on Piles	483
13.11	SI Equations	484
	Summary	484
	References	487
	Problems	487
14	Retaining Walls	490
14.1	Introduction	490
14.2	Types of Retaining Walls	490
14.3	Forces on Retaining Walls	492
14.4	Active and Passive Soil Pressures	493
14.5	Effect of Surcharge	497
14.6	Friction on the Retaining Wall Base	499
14.7	Stability against Overturning	499
14.8	Proportions of Retaining Walls	500

14.9	Design Requirements	501	
14.10	Drainage	502	
14.11	Basement Walls	513	
	Summary	517	
	References	518	
	Problems	518	
15	Design for Torsion		523
15.1	Introduction	523	
15.2	Torsional Moments in Beams	524	
15.3	Torsional Stresses	525	
15.4	Torsional Moment in Rectangular Sections	528	
15.5	Combined Shear and Torsion	529	
15.6	Torsion Theories for Concrete Members	529	
15.7	Torsional Strength of Plain Concrete Members	534	
15.8	Torsion in Reinforced Concrete Members (ACI Code Procedure)	534	
15.9	Summary of ACI Code Procedures	542	
	Summary	550	
	References	551	
	Problems	552	
16	Continuous Beams and Frames		555
16.1	Introduction	555	
16.2	Maximum Moments in Continuous Beams	556	
16.3	Building Frames	561	
16.4	Portal Frames	562	
16.5	General Frames	565	
16.6	Design of Frame Hinges	565	
16.7	Introduction to Limit Design	578	
16.8	The Collapse Mechanism	580	
16.9	Principles of Limit Design	582	
16.10	Upper and Lower Bounds of Load Factors	582	
16.11	Limit Analysis	582	
16.12	Rotation of Plastic Hinges	586	
16.13	Summary of Limit Design Procedure	593	
16.14	Moment Redistribution of Maximum Negative or Positive Moments in Continuous Beams	596	
	Summary	605	
	References	607	
	Problems	607	
17	Design of Two-Way Slabs		610
17.1	Introduction	610	
17.2	Types of Two-Way Slabs	610	
17.3	Economical Choice of Concrete Floor Systems	614	
17.4	Design Concepts	615	
17.5	Column and Middle Strips	619	
17.6	Minimum Slab Thickness to Control Deflection	620	

17.7	Shear Strength of Slabs	624	
17.8	Analysis of Two-Way Slabs by the Direct Design Method	629	
17.9	Design Moments in Columns	658	
17.10	Transfer of Unbalanced Moments to Columns	659	
17.11	Waffle Slabs	672	
17.12	Equivalent Frame Method	681	
	Summary	692	
	References	693	
	Problems	693	
18	Stairs		696
18.1	Introduction	696	
18.2	Types of Stairs	698	
18.3	Examples	713	
	Summary	721	
	References	722	
	Problems	722	
19	Introduction to Prestressed Concrete		724
19.1	Prestressed Concrete	724	
19.2	Materials and Serviceability Requirements	735	
19.3	Loss of Prestress	737	
19.4	Analysis of Flexural Members	746	
19.5	Design of Flexural Members	756	
19.6	Cracking Moment	762	
19.7	Deflection	764	
19.8	Design for Shear	767	
19.9	Preliminary Design of Prestressed Concrete Flexural Members	775	
19.10	End-Block Stresses	777	
	Summary	780	
	References	782	
	Problems	783	
20	Seismic Design of Reinforced Concrete Structures		786
20.1	Introduction	786	
20.2	Seismic Design Category	786	
20.3	Analysis Procedures	804	
20.4	Load Combinations	818	
20.5	Special Requirements in Design of Structures Subjected to Earthquake Loads	819	
	References	856	
	Problems	856	
21	Beams Curved in Plan		858
21.1	Introduction	858	
21.2	Uniformly Loaded Circular Beams	858	
21.3	Semicircular Beam Fixed at End Supports	865	
21.4	Fixed-End Semicircular Beam under Uniform Loading	869	

21.5	Circular Beam Subjected to Uniform Loading	872
21.6	Circular Beam Subjected to a Concentrated Load at Midspan	875
21.7	V-Shape Beams Subjected to Uniform Loading	878
21.8	V-Shape Beams Subjected to a Concentrated Load at the Centerline of the Beam	881
	Summary	885
	References	886
	Problems	886
22	Prestressed Concrete Bridge Design Based on AASHTO LRFD Bridge Design Specifications	887
22.1	Introduction	887
22.2	Typical Cross Sections	888
22.3	Design Philosophy of AASHTO Specifications	891
22.4	Load Factors and Combinations (AASHTO 3.4)	892
22.5	Gravity Loads	896
22.6	Design for Flexural and Axial Force Effects (AASHTO 5.7)	905
22.7	Design for Shear (AASHTO 5.8)	906
22.8	Loss of Prestress (AASHTO 5.9.5)	913
22.9	Deflections (AASHTO 5.7.3.6)	915
	References	944
23	Review Problems on Concrete Building Components	945
24	Design and Analysis Flowcharts	970
	Appendix A: Design Tables (U.S. Customary Units)	994
	Appendix B: Design Tables (SI Units)	1005
	Appendix C: Structural Aids	1013
	Index	1033

# PREFACE

The main objective of a course on structural concrete design is to develop, in the engineering student, the ability to analyze and design a reinforced concrete member subjected to different types of forces in a simple and logical manner using the basic principles of statistics and some empirical formulas based on experimental results. Once the analysis and design procedure is fully understood, its application to different types of structures becomes simple and direct, provided that the student has a good background in structural analysis.

The material presented in this book is based on the requirements of the American Concrete Institute (ACI) Building Standard 318-14, International Building Code IBC-2012, American society of Civil Engineers Load Standards ASCE 7-10, and AASHTO LRFD Bridge Design Specifications. Also, information has been presented on material properties, including volume changes of concrete, stress–strain behavior, creep, and elastic and nonlinear behavior of reinforced concrete.

Concrete structures are widely used in the United States and almost all over the world. The progress in the design concept has increased in the last few decades, emphasizing safety, serviceability, and economy. To achieve economical design of a reinforced concrete member, specific restrictions, rules, and formulas are presented in the codes to ensure both safety and reliability of the structure. Engineering firms expect civil engineering graduates to understand the code rules and, consequently, to be able to design a concrete structure effectively and economically with minimum training period or overhead costs. Taking this into consideration, this book is written to achieve the following objectives:

1. To present the material for the design of reinforced concrete members in a simple and logical approach.
2. To arrange the sequence of chapters in a way compatible with the design procedure of actual structures.
3. To provide a large number of examples in each chapter in clear steps to explain the analysis and design of each type of structural member.
4. To provide an adequate number of practical problems at the end of most chapters to achieve a high level of comprehension.

5. To explain the failure mechanism of a reinforced concrete beam due to flexure and to develop the necessary relationships and formulas for design.
6. To explain *why* the code used specific equations and specific restrictions on the design approach based on either a mathematical model or experimental results. This approach will improve the design ability of the student.
7. To provide adequate number of design aids to help the student in reducing the repetitive computations of specific commonly used values.
8. To enhance the student's ability to use a total quality and economical approach in the design of concrete structures and to help the student to design reinforced concrete members with confidence.
9. To explain the nonlinear behavior and the development of plastic hinges and plastic rotations in continuous reinforced concrete structures.
10. To provide review problems for concrete building component design in Chapter 23.
11. To provide a summary at the end of most chapters to help the student to review the materials of each chapter separately. Also to design and analysis flowcharts in Chapter 24.
12. To provide new information on the design of special members, such as beams with variable depth (Chapter 5), deep beams using ACI and AASHTO design methods (Chapter 8), stairs design (Chapter 18), seismic design utilizing IBC 2012 and ASCE 7-10 (Chapter 20), beams curved in plan (Chapter 21), and bridge design according to AASHTO (Chapter 22).
13. To present information on the design of reinforced concrete frames, principles of limit design, and moment redistribution in continuous reinforced concrete structures.
14. To present examples on prediction of creep and shrinkage of concrete using the ACI and AASHTO codes.
15. To provide examples in SI units in all chapters of the book. Equivalent conversion factors from customary units to SI units are also presented. Design tables in SI units are given in Appendix B.
16. References are presented at the end of most chapters.

The book is an outgrowth of the authors' lecture notes, which represent their teaching and industrial experience over the past 35 years. The industrial experience of the authors includes the design and construction supervision and management of many reinforced, prestressed, and precast concrete structures. This is in addition to the consulting work they performed for international design and construction firms, professional registration in the United Kingdom, Canada, and other countries, and a comprehensive knowledge of other European codes on the design of concrete structures.

The book is written to cover two courses in reinforced concrete design. Depending on the proficiency required, the first course may cover Chapters 1 through 7, 9, 10, 11, 13, 23, and 24, whereas the second course may cover the remaining chapters. Parts of the late chapters may also be taught in the first course as needed. A number of optional sections have been included in various chapters. These sections are indicated by an asterisk (\*) in the Contents and may easily be distinguished from those that form the basic requirements of the first course. The optional sections may be covered in the second course or relegated to a reading assignment. Brief descriptions of the chapters are given below.

The first chapter of the book presents information on the historical development of concrete, codes of practice, loads and safety provisions, and design philosophy and concepts. The second chapter deals with the properties of concrete as well as steel reinforcement used in the design of reinforced concrete structures, including stress-strain relationships, modulus of elasticity and



shear modulus of concrete, shrinkage, creep, fire resistance, high-performance concrete, and fibrous concrete. Because the current ACI Code emphasizes the strength approach based on strain limits, this approach has been adopted throughout the text. Chapters 3 and 4 cover the analysis and design of reinforced concrete sections based on strain limits. The behavior of reinforced concrete beams loaded to failure, the types of flexural failure, and failure mechanism are explained very clearly. It is essential for the student to understand the failure concept and the inherent reserve strength and ductility before using the necessary design formulas.

Chapter 5 covers shear design, including members with variable depth in actual structure.

Chapter 6 deals with the serviceability of reinforced concrete beams, including deflection and control of cracking. Chapter 7 covers bond and development length. Chapter 8 covers the design of deep beams utilizing the ACI and AASHTO strut-and-tie approach.

Chapter 9 covers the design of one-way slabs, including joist-floor systems. Distributions of loads from slabs to beams and columns are also presented in this chapter to enhance the student's understanding of the design loads on each structural component. Chapters 10, 11, and 12 cover the design of axially loaded, eccentrically loaded, and long columns, respectively. Chapter 10 allows the student to understand the behavior of columns, failure conditions, tie and spiral design, and other code limitations. After absorbing the basic information, the student is introduced in Chapter 11 to the design of columns subjected to compression and bending. New mathematical models are introduced to analyze column sections controlled by compression or tension stresses. Biaxial bending for rectangular and circular columns is presented. The design of long columns is discussed in Chapter 12 using the ACI moment-magnifier method.

Chapters 13 and 14 cover the design of footings and retaining walls, then Chapter 15 covers the design of reinforced concrete sections for shear and torsion. Torsional theories and ACI Code design procedure are explained. Chapter 16 deals with continuous beams and frames. A unique feature of this chapter is the introduction of the design of frames, frame hinges, the limit state design collapse mechanism, rotation and plastic hinges, and moment redistribution. Adequate examples are presented to explain these concepts.

The design of two-way slabs is introduced in Chapter 17. All types of two-way slabs, including waffle slabs, are presented with adequate examples. A summary of the design procedure is provided with tables and diagrams. Chapter 18 covers the design of reinforced concrete stairs. Slab-type and stepped-type stairs are explained. The second type, although quite common, has not been covered in any text. Chapter 19 covers an introduction to prestressed concrete. Methods of prestressing, fully and partially prestressed concrete design, losses, and shear design are presented with examples. Chapter 20 presents the seismic design and analysis of members utilizing the IBC 2012, ASCE 7-10, and the ACI Code. Chapter 21 deals with the design of curved beams. In actual structures curved beams are used frequently. These beams are subjected to flexure, shear, and torsion. Chapter 22 covers prestressed concrete bridge design based on the AASHTO LRFD bridge design specifications with design examples. Chapter 23 deals with sample problems review for concrete building component design. Chapter 24 provides flow charts to help the students and engineers to better understand the design and analysis of concrete structure.

In Appendixes A and B, design tables using customary units and SI units are presented.

Finally, the book is written to provide basic reference materials on the analysis and design of structural concrete members in a simple, practical, and logical approach. Because this is a required course for seniors in civil engineering, we believe this book will be accepted by reinforced concrete instructors at different universities as well as designers who can make use of the information in their practical design of reinforced concrete structures.

A companion Web site for the book is available at [www.wiley.com/college/hassoun](http://www.wiley.com/college/hassoun). This Web site contains MSEXcel spreadsheets that enable students to evaluate different design aspects of concrete members in an interactive environment and a solutions manual for instructors.

Our appreciation and thanks go out to Radwa Sakr for the boundless time she spent in helping in the revision of this manuscript and her contributions to the sample problem review chapter. Our thanks also go to Peter Gomez for his contribution to the deep beam chapter, Armando Prada for his contribution to the creep and shrinkage chapter, Peter Park for his contribution to the bridge design chapter, and Pamela Gagnier for her comments on foundation design. We would like to thank Farzam Tondnevis for his constructive comments on the seismic chapter and Maryam Fakhari for reviewing the creep and shrinkage chapter. Also, our appreciation and thanks go to Abdullah Fayyaz, Najah Elias, Snezana Ristanovic, Rashmi Ganerwal, and Vickie Estrada for their contributions to previous editions of the book.

Our sincere thanks go out to Ahmet Pamuk, Florida State University; Nadim Wehbe, South Dakota State University; M. Issa, University of Illinois at Chicago; and Faisal Wafa, King Abdul-Aziz University, for their constructive comments. Our thanks to Basile Rabbat for many discussions on the code interpretation. Special thanks are due to the civil engineering students at South Dakota State University and San Jose State University for their feedback while using the manuscript.

Most of the photos shown in this book were taken by the authors. We wish to express appreciation to John Gardner and Murat Saatcioglu from the University of Ottawa, Canada, for the photos provided in the seismic chapter.

# NOTATION

$a$	Depth of the equivalent rectangular concrete stress block
$a_b$	Value of $a$ for a balanced condition
$A$	Effective tension area of concrete surrounding one bar. (This value is used for control of cracking.)
$A_b$	Area of individual bar
$A_{ch}$	Area of core of spirally reinforced column
$A_{cp}$	Gross area enclosed by outside perimeter of cross section
$ACI$	American Concrete Institute
$A_g$	Gross (total) area of cross section
$A_l$	Total area of longitudinal torsion steel
$A_o$	Gross area enclosed by shear flow $0.85 A_{oh}$
$A_{oh}$	Area enclosed by centerline of the outmost closed transverse torsional reinforcement
$A_{ps}$	Area of prestressed reinforcement in the tension zone
$A_s$	Area of flexural tension steel
$A'_s$	Area of compression steel
$A_{sb}$	Area of balanced steel
$A_{st}$	Total steel area in the section (column)
$A_{sf}$	Area of reinforcement to develop compressive strength of overhanging flanges in T- or L-sections
$A_t$	Area of one leg of close stirrups used to resist torsion
$A_{tc}$	Transformed concrete area
$A_v$	Total area of shear reinforcement within a spacing $S$
$A_l$	Loaded area
$A_2$	Maximum area of supporting surface geometrically similar and concentric with the loaded area
$b$	Width of compression zone at extreme fiber
$b_e$	Effective width of flange
$b_o$	Perimeter of critical section for punching shear
$b_w$	Width of beam web
$c$	Distance from extreme compression fiber to neutral axis
$c_2$	Side of rectangular column measured transverse to the span
$C$	Cross-sectional constant $\sum (1 - 0.63x/y)x^3y/3$ ; compression force

$C_c$	Compression force in a concrete section with a depth equal to a
$C_m$	Correction factor applied to the maximum end moment in columns
$C_r$	Creep coefficient = creep strain per unit stress per unit length
$C_s$	Force in compression steel
$C_t$	Factor relating shear and torsional stress properties = $b_w d / \sum x^2 y$
$C_w$	Compression force in web
$C_l$	Force in the compression steel
$d$	Distance from extreme compression fiber to centroid of tension steel
$d'$	Distance from extreme compression fiber to centroid of compression steel
$d_b$	Nominal diameter of reinforcing bar
$d_c$	Distance from tension extreme fiber to center of bar closest to that fiber, used for crack control
$d_t$	Distance from extreme compression fibers to extreme tension steel
$D$	Dead load, diameter of a circular section
$e$	Eccentricity of load
$e'$	Eccentricity of load with respect to centroid of tension steel
$E$	Modulus of elasticity, force created by earthquake
$E_c$	Modulus of elasticity of concrete = $33w^{1.5}\sqrt{f'_c}$
$E_{cb}$	Modulus of elasticity of beam concrete
$E_{cc}$	Modulus of elasticity of column concrete
$E_{cs}$	Modulus of elasticity of slab concrete
$EI$	Flexural stiffness of compression member
$E_s$	Modulus of elasticity of steel = $29 \times 10^6$ psi = $2 \times 10^5$ MPa
$f$	Flexural stress
$f_c$	Maximum flexural compressive stress in concrete due to service loads
$f_{ca}$	Allowable compressive stress in concrete (alternate design method)
$f'_c$	28-day compressive strength of concrete (standard cylinder strength)
$f_d$	Compressive strength of concrete at transfer (initial prestress)
$f_{pc}$	Compressive stress in concrete due to prestress after all losses
$f_{pe}$	Compressive stress in concrete at extreme fiber due to the effective prestressing force after all losses
$f_{ps}$	Stress in prestress steel at nominal strength
$f_{pu}$	Tensile strength of prestressing tendons
$f_{py}$	Yield strength of prestressing tendons
$f_r$	Modulus of rupture of concrete = $7.5\lambda\sqrt{f'_c}$ psi
$f_s$	Stress in tension steel due to service load
$f'_s$	Stress in the compression steel due to service load
$f_{se}$	Effective stress in prestressing steel after all losses
$f_t$	Tensile stress in concrete
$f_y$	Specified yield strength of steel reinforcement
$f_{yt}$	Specified yield strength of transverse reinforcement
$F$	Loads due to weight and pressure of fluids
$F_n$	Nominal strength of a strut, tie, or nodal zone
$F_{ns}$	Nominal strength of a strut
$F_{nt}$	Nominal strength of a tie
$G$	Shear modulus of concrete (in torsion) = $0.45E_c$
$h$	Total depth of beam or slab or column
$h_f$	Depth of flange in flanged sections
$h_p$	Total depth of shearhead cross section
$H$	Lateral earth pressure
$I$	Moment of inertia

$I_b$	Moment of inertia of gross section of beam about its centroidal axis
$I_c$	Moment of inertia of gross section of column
$I_{cr}$	Moment of inertia of cracked transformed section
$I_e$	Effective moment of inertia, used in deflection
$I_g$	Moment of inertia of gross section neglecting steel
$I_s$	Moment of inertia of gross section of slab
$I_{se}$	Moment of inertia of steel reinforcement about centroidal axis of section
$J$	Polar moment of inertia
$K$	kip = 1000 lb, a factor used to calculate effective column length
$K_b$	Flexural stiffness of beam
$K_c$	Flexural stiffness of column
$K_{ec}$	Flexural stiffness of equivalent column
$K_s$	Flexural stiffness of slab
$K_t$	Torsional stiffness of torsional member
kN	Kilonewton
ksi	Kip per square inch
$\ell_c$	Length of compression member in a frame
$\ell_n$	Clear span
$\ell_u$	Unsupported length of column
$L$	Live load, span length
$L_r$	Roof live load
$l_d$	Development length
$L_{dc}$	Development length in compression
$l_{dh}$	Development length in tension of a standard hook
$l_{hb}$	Basic development length of a standard hook
$l_n$	Clear span
$l_u$	Unsupported length of compression member
$l_v$	Length of shearhead arm
$l_1$	Span length in the direction of moment
$l_2$	Span length in direction transverse to span $l_1$
$M$	Bending moment
$M_1$	Smaller factored end moment at end of column
$M_2$	Larger factored end moment at end of column
$M_a$	Maximum service load moment
$M_b$	Balanced moment in columns, used with $P_b$
$M_c$	Factored moment amplified for long columns
$M_{cr}$	Cracking moment
$M_{cre}$	Moment causing flexural cracking at a section
$M_m$	Factored modified moment
$M_n$	Nominal moment strength = $M_u/\phi$
$M'_n$	Nominal moment strength using an eccentricity $e'$
$M_0$	Total factored moment
$M_p$	Plastic moment
$M_u$	Moment strength due to factored loads
$M_{u1}$	Part of $M_u$ when calculated as singly reinforced
$M_{u2}$	Part of $M_u$ due to compression reinforcement or overhanging flanges in T- or L-sections
$M'_u$	Moment strength using an eccentricity $e'$
$M_v$	Shearhead moment resistance
$M_{1ns}$	Factored end moment in nonsway frame at which $M_1$ acts

$M_{1s}$	Factored end moment in sway frame at which $M_1$ acts
$M_{2,\min}$	Minimum value of $M_2$ in columns
$M_{2ns}$	Factored end moment in nonsway frame at which $M_2$ acts
$M_{2s}$	Factored end moment in sway frame at which $M_2$ acts
$n$	Modular ratio = $E_s/E_c$
$N$	Normal force
$N_u$	Factored normal load
$N_1$	Normal force in bearing at base of column
NA	Neutral axis
psi	Pounds per square inch
$P_{cp}$	Outside perimeter of gross area = $2(x_0 + y_0)$
$P$	Unfactored concentrated load
$P_b$	Balanced load in column (at failure)
$P_c$	Euler buckling load
$P_n$	Nominal axial strength of column for a given $e$
$P_0$	Perimeter of shear flow in area $A_0$
$P_0$	Axial strength of a concentrically loaded column
$P_s$	Prestressing force in the tendon at the jacking end
$P_u$	Factored load = $\phi P_n$
$P_x$	Prestressing force in the tendon at any point $x$
$q$	Soil-bearing capacity
$q_a$	Allowable bearing capacity of soil
$q_u$	Ultimate bearing capacity of soil using factored loads
$Q$	Stability index for a story
$r$	Radius of gyration, radius of a circle
$R$	Resultant of force system, reduction factor for long columns, or $R = R_u/\phi$ , also rain load
$R_u$	A factor = $M_u/bd^2$
$S$	Snow loads
$s$	Spacing between bars, stirrups, or ties
SI	International System of Units
$t$	Thickness of a slab
$T$	Torque, tension force
$T_c$	Nominal torsional strength provided by concrete
$T_{cr}$	Cracking torsional moment
$T_n$	Nominal torsional strength provided by concrete and steel
$T_s$	Nominal torsional strength provided by reinforcement
$T_u$	Torque provided by factored load = $\phi T_n$
$u$	Bond stress
$U$	Design strength required to resist factored loads
$V$	Shear stress produced by working loads
$v_c$	Shear stress of concrete
$v_{cr}$	Shear stress at which diagonal cracks develop
$v_h$	Horizontal shear stress
$v_t$	Shear stress produced by a torque
$v_u$	Shear stress produced by factored loads
$V$	Unfactored shear force
$V_c$	Shear strength of concrete
$V_{ci}$	Nominal shear strength of concrete when diagonal cracking results from combined shear and moment
$V_{cw}$	Nominal shear strength of concrete when diagonal cracking results from excessive principal tensile stress in web

$V_d$	Shear force at section due to unfactored dead load ( $d$ = distance from the face of support)
$V_n$	Nominal shear strength = $V_c + V_s$
$V_p$	Vertical component of effective prestress force at section
$V_s$	Shear strength carried by reinforcement
$V_u$	Shear force due to factored loads
$w$	Width of crack at the extreme tension fiber, unit weight of concrete
$w_u$	Factored load per unit length of beam or per unit area of slab
$W$	Wind load or total load
$x_0$	Length of the short side of a rectangular section
$x_1$	Length of the short side of a rectangular closed stirrup
$y_b$	Same as $y_t$ , except to extreme bottom fibers
$y_0$	Length of the long side of a rectangular section
$y_t$	Distance from centroidal axis of gross section, neglecting reinforcement, to extreme top fiber
$y_l$	Length of the long side of a rectangular closed stirrup
$\alpha$	Angle of inclined stirrups with respect to longitudinal axis of beam, ratio of stiffness of beam to that of slab at a joint
$\alpha_c$	Ratio of flexural stiffness of columns to combined flexural stiffness of the slabs and beams at a joint; $(\Sigma K_c)/\Sigma(K_s + K_b)$
$\alpha_{ec}$	Ratio of flexural stiffness of equivalent column to combined flexural stiffness of the slabs and beams at a joint: $(K_{ec})/\Sigma(K_s + K_b)$
$\alpha_f$	$(E_{cb}I_b/E_{cs}I_s)$
$\alpha_{f1}$	$\alpha_f$ in direction $\ell_1$
$\alpha_{f2}$	$\alpha_f$ in direction $\ell_2$
$\alpha_m$	Average value of $\alpha$ for all beams on edges of a panel
$\alpha_v$	Ratio of stiffness of shearhead arm to surrounding composite slab section
$\beta$	Ratio of long to short side of rectangular footing, measure of curvature in biaxial bending
$\beta_1$	Ratio of $a/c$ , where $a$ = depth of stress block and $c$ = distance between neutral axis and extreme compression fibers. (This factor is 0.85 for $f'_c \leq 4000$ psi and decreases by 0.05 for each 1000 psi in excess of 4000 psi but is at least 0.65.)
$\beta_a$	Ratio of unfactored dead load to unfactored live load per unit area
$\beta_c$	Ratio of long to short sides of column or loaded area
$\beta_{ds}$	Ratio used to account for reduction of stiffness of columns due to sustained lateral load
$\beta_{dns}$	Ratio of maximum factored dead load moment to maximum factored total moment
$\beta_t$	Ratio of torsional stiffness of edge beam section to flexural stiffness of slab: $E_{cb}C/2E_{cs}I_s$
$\gamma$	Distance between rows of reinforcement on opposite sides of columns to total depth of column $h$
$\gamma_f$	Fraction of unbalanced moment transferred by flexure at slab–column connections
$\gamma_p$	Factor for type of prestressing tendon (0.4 or 0.28)
$\gamma_v$	Fraction of unbalanced moment transferred by eccentricity of shear at slab–column connections
$\delta$	Magnification factor
$\delta_{ns}$	Moment magnification factor for frames braced against sidesway
$\delta_s$	Moment magnification factor for frames not braced against sidesway
$\Delta$	Deflection
$\epsilon$	Strain
$\epsilon_c$	Strain in concrete
$\epsilon_s$	Strain in steel
$\epsilon'_s$	Strain in compression steel
$\epsilon_y$	Yield strain = $f_y/E_s$
$\theta$	Slope angle
$\lambda$	Multiplier factor for reduced mechanical properties of lightweight concrete
$\lambda_\Delta$	Multiplier for additional long-time deflection
$\mu$	Poisson's ratio; coefficient of friction

$\zeta$	Parameter for evaluating capacity of standard hook
$\pi$	Constant equal to approximately 3.1416
$\rho$	Ratio of the tension steel area to the effective concrete area = $A_s/bd$
$\rho'$	Ratio of compression steel area to effective concrete area = $A'_s/bd$
$\rho_1$	$\rho - \rho'$
$\rho_b$	Balanced steel ratio
$\rho_g$	Ratio of total steel area to total concrete area
$\rho_p$	Ratio of prestressed reinforcement $A_{ps}/bd$
$\rho_s$	Ratio of volume of spiral steel to volume of core
$\rho_w$	$A_s/b_wd$
$\phi$	Strength reduction factor
$\psi_e$	Factor used to modify development length based on reinforcement coating
$\psi_s$	Factor used to modify development length based on reinforcing size
$\psi_t$	Factor used to modify development length based on reinforcement location
$\omega$	Tension reinforcing index = $\rho f_y/f'_c$
$\omega'$	Compression reinforcing index = $\rho' f_y/f'_c$
$\omega_p$	Prestressed steel index = $\rho_p f_{ps}/f'_c$
$\omega_{pw}$	Prestressed steel index for flanged sections
$\omega_w$	Tension reinforcing index for flanged sections
$\omega'_w$	Compression reinforcing index for flanged sections computed as for $\omega$ , $\omega_p$ , and $\omega'$



# CONVERSION FACTORS

<b>To Convert</b>	<b>to</b>	<b>Multiply By</b>
<i>1. Length</i>		
Inch	Millimeter	25.4
Foot	Millimeter	304.8
Yard	Meter	0.9144
Meter	Foot	3.281
Meter	Inch	39.37
<i>2. Area</i>		
Square inch	Square millimeter	645
Square foot	Square meter	0.0929
Square yard	Square meter	0.836
Square meter	Square foot	10.76
<i>3. Volume</i>		
Cubic inch	Cubic millimeter	16390
Cubic foot	Cubic meter	0.02832
Cubic yard	Cubic meter	0.765
Cubic foot	Liter	28.3
Cubic meter	Cubic foot	35.31
Cubic meter	Cubic yard	1.308
<i>4. Mass</i>		
Ounce	Gram	28.35
Pound (lb)	Kilogram	0.454
Pound	Gallon	0.12
Short ton (2000 lb)	Kilogram	907
Long ton (2240 lb)	Kilogram	1016
Kilogram	Pound (lb)	2.205
Slug	Kilogram	14.59

(continued)

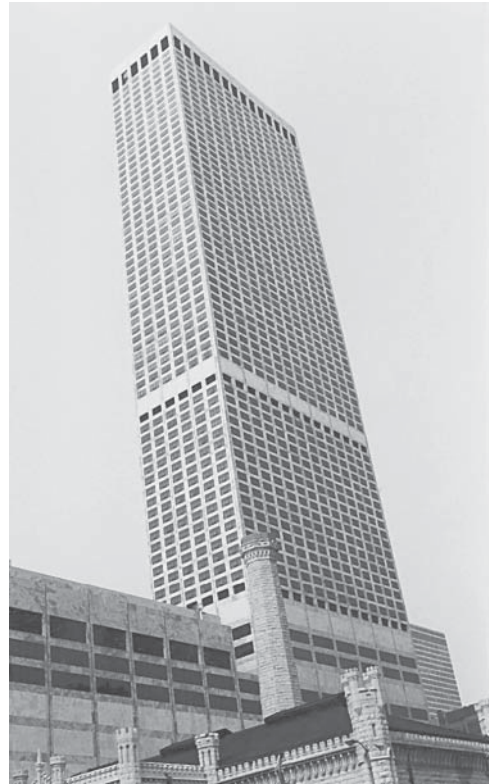
<b>To Convert</b>	<b>to</b>	<b>Multiply By</b>
<i>5. Density</i>		
Pound/cubic foot	Kilogram/cubic meter	16.02
Kilogram/cubic meter	Pound/cubic foot	0.06243
<i>6. Force</i>		
Pound (lb)	Newton (N)	4.448
Kip (1000 lb)	Kilonewton (kN)	4.448
Newton (N)	Pound	0.2248
Kilonewton (kN)	Kip (K)	0.225
<i>7. Force/length</i>		
Kip/foot	Kilonewton/meter	14.59
Kilonewton/meter	Pound/foot	68.52
Kilonewton/meter	Kip/foot	0.06852
<i>8. Force/area (stress)</i>		
Pound/square inch (psi)	Newton/square centimeter	0.6895
Pound/square inch (psi)	Newton/square millimeter (MPa)	0.0069
Kip/square inch (ksi)	Meganewton/square meter	6.895
Kip/square inch (ksi)	Newton/square millimeter	6.895
Pound/square foot	Kilonewton/square meter	0.04788
Pound/square foot	Newton/square meter	47.88
Kip/square foot	Kilonewton/square meter	47.88
Newton/square millimeter	Kip/square inch (Ksi)	0.145
Kilonewton/square meter	Kip/square foot	0.0208
Kilonewton/square meter	Pound/square foot	20.8
<i>9. Moments</i>		
Foot·kip	Kilonewton·meter	1.356
Inch·kip	Kilonewton·meter	0.113
Inch·kip	Kilogram force·meter	11.52
Kilonewton·meter	Foot·kip	0.7375

# Structural Concrete



# CHAPTER 1

## INTRODUCTION



Water Tower Place, Chicago, 74 stories, tallest concrete building in the United States.

### 1.1 STRUCTURAL CONCRETE

The design of different structures is achieved by performing, in general, two main steps: (1) determining the different forces acting on the structure using proper methods of structural analysis and (2) proportioning all structural members economically, considering the safety, stability, serviceability, and functionality of the structure. Structural concrete is one of the materials commonly used to design all types of buildings. Its two component materials, concrete and steel, work together to form structural members that can resist many types of loadings. The key to its performance lies in strengths that are complementary: Concrete resists compression and steel reinforcement resists tension forces.

The term *structural concrete* indicates all types of concrete used in structural applications. Structural concrete may be plain, reinforced, prestressed, or partially prestressed concrete; in addition, concrete is used in composite design. Composite design is used for any structural member, such as beams or columns, when the member contains a combination of concrete and steel shapes.

### 1.2 HISTORICAL BACKGROUND

The first modern record of concrete is as early as 1760, when John Smeaton used it in Britain in the first lock on the river Calder [1]. The walls of the lock were made of stones filled in with

concrete. In 1796, J. Parker discovered Roman natural cement, and 15 years later Vicat burned a mixture of clay and lime to produce cement. In 1824, Joseph Aspdin manufactured portland cement in Wakefield, Britain. It was called portland cement because when it hardened it resembled stone from the quarries of the Isle of Portland.

In France, François Marte Le Brun built a concrete house in 1832 in Moissac in which he used concrete arches of 18-ft span. He used concrete to build a school in St. Aignan in 1834 and a church in Corbarière in 1835. Joseph Louis Lambot [2] exhibited a small rowboat made of reinforced concrete at the Paris Exposition in 1854. In the same year, W. B. Wilkinson of England obtained a patent for a concrete floor reinforced by twisted cables. The Frenchman François Cignet obtained his first patent in 1855 for his system of iron bars, which were embedded in concrete floors and extended to the supports. One year later, he added nuts at the screw ends of the bars, and in 1869, he published a book describing the applications of reinforced concrete.

Joseph Monier, who obtained his patent in Paris on July 16, 1867, was given credit for the invention of reinforced concrete [3]. He made garden tubs and pots of concrete reinforced with iron mesh, which he exhibited in Paris in 1867. In 1873, he registered a patent to use reinforced concrete in tanks and bridges, and four years later, he registered another patent to use it in beams and columns [1].

In the United States, Thaddeus Hyatt conducted flexural tests on 50 beams that contained iron bars as tension reinforcement and published the results in 1877. He found that both concrete and steel can be assumed to behave in a homogeneous manner for all practical purposes. This assumption was important for the design of reinforced concrete members using elastic theory. He used prefabricated slabs in his experiments and considered prefabricated units to be best cast in T-sections and placed side by side to form a floor slab. Hyatt is generally credited with developing the principles upon which the analysis and design of reinforced concrete are now based.

A reinforced concrete house was built by W. E. Ward near Port Chester, New York, in 1875. It used reinforced concrete for walls, beams, slabs, and staircases. P. B. Write wrote in the *American Architect and Building News* in 1877 describing the applications of reinforced concrete in Ward's house as a new method in building construction.

E. L. Ransome, head of the Concrete Steel Company in San Francisco, used reinforced concrete in 1879 and deformed bars for the first time in 1884. During 1889 to 1891, he built the two-story Leland Stanford Museum in San Francisco using reinforced concrete. He also built a reinforced concrete bridge in San Francisco. In 1900, after Ransome introduced the reinforced concrete skeleton, the thick wall system started to disappear in construction. He registered the skeleton type of structure in 1902 using spiral reinforcement in the columns, as was suggested by Armand Considère of France. A. N. Talbot, of the University of Illinois, and F. E. Turneaure and M. O. Withney, of the University of Wisconsin, conducted extensive tests on concrete to determine its behavior, compressive strength, and modulus of elasticity.

In Germany, G. A. Wayass bought the French Monier patent in 1879 and published his book on Monier methods of construction in 1887. Rudolph Schuster bought the patent rights in Austria, and the name of Monier spread throughout Europe, which is the main reason for crediting Monier as the inventor of reinforced concrete.

In 1900, the Ministry of Public Works in France called for a committee headed by Armand Considère, chief engineer of roads and bridges, to establish specifications for reinforced concrete, which were published in 1906.

Reinforced concrete was further refined by introducing some precompression in the tension zone to decrease the excessive cracks. This refinement was the preliminary introduction of partial and full prestressing. In 1928, Eugene Freyssinet established the practical technique of using prestressed concrete [4].



The Barkwick House, a three-story concrete building built in 1905, Montreal, Canada.

From 1915 to 1935, research was conducted on axially loaded columns and creep effects on concrete; in 1940, eccentrically loaded columns were investigated. Ultimate-strength design started to receive special attention, in addition to diagonal tension and prestressed concrete. The American Concrete Institute Code (ACI Code) specified the use of ultimate-strength design in 1963 and included this method in all later codes. The method is called in the current ACI code the strength design method. Building codes and specifications for the design of reinforced concrete structures are established in most countries, and research continues on developing new applications and more economical designs.

### 1.3 ADVANTAGES AND DISADVANTAGES OF REINFORCED CONCRETE

Reinforced concrete, as a structural material, is widely used in many types of structures. It is competitive with steel if economically designed and executed.

The advantages of reinforced concrete can be summarized as follows:

1. It has a relatively high compressive strength.
2. It has better resistance to fire than steel.
3. It has a long service life with low maintenance cost.
4. In some types of structures, such as dams, piers, and footings, it is the most economical structural material.
5. It can be cast to take the shape required, making it widely used in precast structural components. It yields rigid members with minimum apparent deflection.

The disadvantages of reinforced concrete can be summarized as follows:

1. It has a low tensile strength of about one-tenth of its compressive strength.
2. It needs mixing, casting, and curing, all of which affect the final strength of concrete.
3. The cost of the forms used to cast concrete is relatively high. The cost of form material and artisanry may equal the cost of concrete placed in the forms.
4. It has a low compressive strength as compared to steel (the ratio is about 1:10, depending on materials), which leads to large sections in columns of multistory buildings.
5. Cracks develop in concrete due to shrinkage and the application of live loads.

#### 1.4 CODES OF PRACTICE

The design engineer is usually guided by specifications called the codes of practice. Engineering specifications are set up by various organizations to represent the minimum requirements necessary for the safety of the public, although they are not necessarily for the purpose of restricting engineers.

Most codes specify design loads, allowable stresses, material quality, construction types, and other requirements for building construction. The most significant standard for structural concrete design in the United States is the Building Code Requirements for Structural Concrete, ACI 318, or the ACI Code. Most of the design examples of this book are based on this standard. Other codes of practice and material specifications in the United States include the International building Code (IBC), The American Society of Civil Engineers standard ASCE 7, The American Association of State Highway and Transportation Officials (AASHTO) specifications, and specifications issued by the American Society for Testing and Materials (ASTM), the American Railway Engineering Association (AREA), and the Bureau of Reclamation, Department of the Interior.

#### 1.5 DESIGN PHILOSOPHY AND CONCEPTS

The design of a structure may be regarded as the process of selecting the proper materials and proportioning the different elements of the structure according to state-of-the-art engineering science and technology. In order to fulfill its purpose, the structure must meet the conditions of safety, serviceability, economy, and functionality. This can be achieved using design approach-based strain limits in concrete and steel reinforcement.

The unified design method (UDM) is based on the strength of structural members assuming a failure condition, whether due to the crushing of the concrete or to the yield of the reinforcing steel bars. Although there is some additional strength in the bars after yielding (due to strain hardening), this additional strength is not considered in the analysis of reinforced concrete members. In this approach, the actual loads, or working loads, are multiplied by load factors to obtain the factored design loads. The load factors represent a high percentage of the factor for safety required in the design. Details of this method are presented in Chapters 3, 4, and 11. The ACI Code emphasizes this method of design, and its provisions are presented in the body of the Code. The reason for introducing this approach by the ACI Code relates to the fact that different design methods were developed for reinforced and prestressed concrete beams and columns. Also, design procedures for prestressed concrete were different from reinforced concrete. The purpose of the Code approach is to simplify and unify the design requirements for reinforced and prestressed flexural members and compression members.



A second approach for the design of concrete members is called the strut-and-tie method (STM). The provisions of this method are introduced in the ACI Code, Chapter 23. It applies effectively in regions of discontinuity such as support and load applications on beams. Consequently, the structural element is divided into segments and then analyzed using the truss analogy approach, where the concrete resists compression forces as a strut, while the steel reinforcement resists tensile forces as a tie.

A basic method that is not commonly used is called the working stress design or the elastic design method. The design concept is based on the elastic theory assuming a straight-line stress distribution along the depth of the concrete section under service loads. The members are proportioned on the basis of certain allowable stresses in concrete and steel. The allowable stresses are fractions of the crushing strength of concrete and yield strength of steel. This method has been deleted from the ACI Code. The application of this approach is still used in the design of prestressed concrete members under service load conditions, as shown in Chapter 19.

Limit state design is a further step in the strength design method. It indicates the state of the member in which it ceases to meet the service requirements such as losing its ability to withstand external loads or suffering excessive deformation, cracking, or local damage. According to the limit state design, reinforced concrete members have to be analyzed with regard to three limiting states:

1. Load-carrying capacity (safety, stability, and durability)
2. Deformation (deflections, vibrations, and impact)
3. Formation of cracks

The aim of this analysis is to ensure that no limiting state will appear in the structural member during its service life.

## 1.6 UNITS OF MEASUREMENT

Two units of measurement are commonly used in the design of structural concrete. The first is the U.S. customary system (lying mostly in its human scale and its ingenious use of simple numerical proportions), and the second is the SI (Système International d'Unités), or metric, system.

The metric system is expected to be in universal use within the coming few years. The United States is committed to changing to SI units. Great Britain, Canada, Australia, and other countries have been using SI units for many years.

The base units in the SI system are the units of length, mass, and time, which are the meter (m), the kilogram (kg), and the second (s), respectively. The unit of force, a derived unit called the newton (N), is defined as the force that gives the acceleration of one meter per second ( $1 \text{ m/s}^2$ ) to a mass of one kilogram, or  $1 \text{ N} = 1 \text{ kg} \times \text{m/s}^2$ .

The weight of a body,  $W$ , which is equal to the mass,  $m$ , multiplied by the local gravitational acceleration,  $g$  ( $9.81 \text{ m/s}^2$ ), is expressed in newtons (N). The weight of a body of 1 kg mass is  $W = mg = 1 \text{ kg} \times 9.81 \text{ m/s}^2 = 9.81 \text{ N}$ .

Multiples and submultiples of the base SI units can be expressed through the use of prefixes. The prefixes most frequently used in structural calculations are the kilo (k), mega (M), milli (m), and micro ( $\mu$ ). For example,

$$\begin{array}{lll} 1 \text{ km} = 1000 \text{ m} & 1 \text{ mm} = 0.001 \text{ m} & 1 \mu\text{m} = 10^{-6} \text{ m} \\ 1 \text{ kN} = 1000 \text{ N} & 1 \text{ Mg} = 1000 \text{ kg} = 10^6 \text{ g} & \end{array}$$

## 1.7 LOADS

Structural members must be designed to support specific loads.

Loads are those forces for which a given structure should be proportioned. In general, loads may be classified as dead or live.

Dead loads include the weight of the structure (its self-weight) and any permanent material placed on the structure, such as tiles, roofing materials, and walls. Dead loads can be determined with a high degree of accuracy from the dimensions of the elements and the unit weight of materials.

Live loads are all other loads that are not dead loads. They may be steady or unsteady or movable or moving; they may be applied slowly, suddenly, vertically, or laterally, and their magnitudes may fluctuate with time. In general, live loads include the following:

- Occupancy loads caused by the weight of the people, furniture, and goods
- Forces resulting from wind action and temperature changes
- The weight of snow if accumulation is probable
- The pressure of liquids or earth on retaining structures
- The weight of traffic on a bridge
- Dynamic forces resulting from moving loads (impact), earthquakes, or blast loading

The ACI Code does not specify loads on structures; however, occupancy loads on different types of buildings are prescribed by IBC-2012 and the American National Standards Institute (ANSI) [5]. Some typical values are shown in Table 1.1. Table 1.2 shows the weights and specific gravity of various materials.

**Table 1.1** Typical Uniformly Distributed Design Loads

Occupancy	Contents	Design Live Load	
		lb/ft <sup>2</sup>	kN/m <sup>2</sup>
Assembly hall	Fixed seats	60	2.9
	Movable seats	100	4.8
Hospital	Operating rooms	60	2.9
	Private rooms	40	1.9
Hotel	Guest rooms	40	1.9
	Public rooms	100	4.8
	Balconies	100	4.8
Housing	Private houses and apartments	40	1.9
	Public rooms	100	4.8
Institution	Classrooms	40	1.9
	Corridors	100	4.8
Library	Reading rooms	60	2.9
	Stack rooms	150	7.2
Office building	Offices	50	2.4
	Lobbies	100	4.8
Stairs (or balconies)		100	4.8
Storage warehouses	Light	100	4.8
	Heavy	250	12.0
Yards and terraces		100	4.8

**Table 1.2** Density and Specific Gravity of Various Materials

Material	Density		Specific Gravity
	lb/ft <sup>3</sup>	kg/m <sup>3</sup>	
Building materials			
Bricks	120	1924	1.8–2.0
Cement, portland, loose	90	1443	—
Cement, portland, set	183	2933	2.7–3.2
Earth, dry, packed	95	1523	—
Sand or gravel, dry, packed	100–120	1600–1924	—
Sand or gravel, wet	118–120	1892–1924	—
Liquids			
Oils	58	930	0.9–0.94
Water (at 4°C)	62.4	1000	1.0
Ice	56	898	0.88–0.92
Metals and minerals			
Aluminum	165	2645	2.55–2.75
Copper	556	8913	9.0
Iron	450	7214	7.2
Lead	710	11,380	11.38
Steel, rolled	490	7855	7.85
Limestone or marble	165	2645	2.5–2.8
Sandstone	147	2356	2.2–2.5
Shale or slate	175	2805	2.7–2.9
Normal-weight concrete			
Plain	145	2324	2.2–2.4
Reinforced or prestressed	150	2405	2.3–2.5

AASHTO and AREA specifications prescribe vehicle loadings on highway and railway bridges, respectively. These loads are given in References 6 and 7.

Snow loads on structures may vary between 10 and 40 lb/ft<sup>2</sup> (0.5 and 2 kN/m<sup>2</sup>), depending on the local climate.

Wind loads may vary between 15 and 30 lb/ft<sup>2</sup>, depending on the velocity of wind. The wind pressure of a structure,  $F$ , can be estimated from the equation

$$F = 0.00256C_s V^2 \quad (1.1)$$

where

$V$  = velocity of air (mi/h)

$C_s$  = shape factor of structure

$F$  = dynamic wind pressure (lb/ft<sup>2</sup>)

As an example, for a wind of 100 mi/h with  $C_s = 1$ , the wind pressure is equal to 25.6 lb/ft<sup>2</sup>. It is sometimes necessary to consider the effect of gusts in computing the wind pressure by multiplying the wind velocity in Eq. 1.1 by a gust factor, which generally varies between 1.1 and 1.3.

The shape factor,  $C_s$ , varies with the horizontal angle of incidence of the wind. On vertical surfaces of rectangular buildings,  $C_s$  may vary between 1.2 and 1.3. Detailed information on wind loads can be found in Reference 5.

## 1.8 SAFETY PROVISIONS

Structural members must always be proportioned to resist loads greater than the service or actual load in order to provide proper safety against failure. In the strength design method, the member is designed to resist factored loads, which are obtained by multiplying the service loads by load factors. Different factors are used for different loadings. Because dead loads can be estimated quite accurately, their load factors are smaller than those of live loads, which have a high degree of uncertainty. Several load combinations must be considered in the design to compute the maximum and minimum design forces. Reduction factors are used for some combinations of loads to reflect the low probability of their simultaneous occurrences. The ACI Code presents specific values of load factors to be used in the design of concrete structures (see Chapter 3, Section 3.5).

In addition to load factors, the ACI Code specifies another factor to allow an additional reserve in the capacity of the structural member. The nominal strength is generally calculated using an accepted analytical procedure based on statistics and equilibrium; however, in order to account for the degree of accuracy within which the nominal strength can be calculated, and for adverse variations in materials and dimensions, a strength reduction factor,  $\phi$ , should be used in the strength design method. Values of the strength reduction factors are given in Chapter 3, Section 3.6.

To summarize the above discussion, the ACI Code has separated the safety provision into an overload or load factor and to an undercapacity (or strength reduction) factor,  $\phi$ . A safe design is achieved when the structure's strength, obtained by multiplying the nominal strength by the reduction factor,  $\phi$ , exceeds or equals the strength needed to withstand the factored loadings (service loads times their load factors). For example,

$$M_u \leq \phi M_n \quad \text{and} \quad V_u \leq \phi V_n \quad (1.2)$$

where

$M_u, V_u$  = external factored moment and shear forces, respectively

$M_n, V_n$  = nominal flexural strength and shear strength of member, respectively

Given a load factor of 1.2 for dead load and a load factor of 1.6 for live load, the overall safety factor for a structure loaded by a dead load,  $D$ , and a live load,  $L$ , is

$$\text{Factor of safety} = \frac{1.2D + 1.6L}{D + L} \left( \frac{1}{\phi} \right) = \frac{1.2 + 1.6(L/D)}{1 + (L/D)} \left( \frac{1}{\phi} \right) \quad (1.3)$$

The factors of safety for the various values of  $\phi$  and  $L/D$  ratios are as follows:

$\phi$	0.9				0.8				0.75				
	L/D	0	1	2	3	0	1	2	3	0	1	2	3
Factor of safety		1.33	1.56	1.63	1.67	1.50	1.74	1.83	1.88	1.6	1.87	1.96	2

For members subjected to flexure (beams), with tension-controlled sections,  $\phi = 0.9$ , and the factor of safety ranges between 1.33 for  $L/D = 0$  and 1.67 for  $L/D = 3$ . These values are less than those specified by the ACI Code 318 Appendix C of 1.56 for  $L/D = 0$  and 1.81 for  $L/D = 3.0$  based on load factors of 1.4 for dead load and 1.7 for live load. This reduction ranges between 17 and 8%, respectively.

For members subjected to axial forces (spiral columns),  $\phi = 0.75$ , and the factor of safety ranges between 1.60 for  $L/D = 0$  and 2 for  $L/D = 3$ . The increase in the factor of safety in columns reflects the greater overall safety requirements of these critical building elements.

A general format of Eq. 1.2 may be written as [8]

$$\phi R \geq v_0 \sum (v_i Q_i) \quad (1.4)$$

where

- $R_n$  = nominal strength of structural number
- $\phi$  = undercapacity factor (Reduction factor <1.0)
- $\sum Q_i$  = sum of load effects
- $v_i$  = overload factor
- $v_0$  = analysis factor (>1.0)

The subscript  $i$  indicates the load type, such as dead load, live load, and wind load. The analysis factor,  $v_0$ , is greater than 1.0 and is introduced to account for uncertainties in structural analysis. The overload factor,  $v_i$ , is introduced to account for several factors such as an increase in live load due to a change in the use of the structure and variations in erection procedures. The design concept is referred to as load and resistance factor design (LRFD).

## 1.9 STRUCTURAL CONCRETE ELEMENTS

Structural concrete can be used for almost all buildings, whether single story or multistory. The concrete building may contain some or all of the following main structural elements, which are explained in detail in other chapters of the book:

- *Slabs* are horizontal plate elements in building floors and roofs. They may carry gravity loads as well as lateral loads. The depth of the slab is usually very small relative to its length or width (Chapters 9 and 17).
- *Beams* are long, horizontal, or inclined members with limited width and depth. Their main function is to support loads from slabs (Chapters 3, 4, and 8).
- *Columns* are critical members that support loads from beams or slabs. They may be subjected to axial loads or axial loads and moments (Chapters 10, 11, and 12).
- *Frames* are structural members that consist of a combination of beams and columns or slabs, beams, and columns. They may be statically determinate or statically indeterminate frames (Chapter 16).
- *Footings* are pads or strips that support columns and spread their loads directly to the soil (Chapter 13).
- *Walls* are vertical plate elements resisting gravity as well as lateral loads as in the case of basement walls (Chapter 14).
- *Stairs* are provided in all buildings either low or high rise (Chapter 18).

## 1.10 STRUCTURAL CONCRETE DESIGN

The first step in the design of a building is the general planning carried out by the architect to determine the layout of each floor of the building to meet the owner's requirements. Once the

architectural plans are approved, the structural engineer then determines the most adequate structural system to ensure the safety and stability of the building. Different structural options must be considered to determine the most economical solution based on the materials available and the soil condition. This result is normally achieved by:

1. Idealizing the building into a structural model of load-bearing frames and elements
2. Estimating the different types of loads acting on the building
3. Performing the structural analysis using computer or manual calculations to determine the maximum moments, shear, torsional forces, axial loads, and other forces
4. Proportioning the different structural elements and calculating the reinforcement needed
5. Producing structural drawings and specifications with enough details to enable the contractor to construct the building properly

### 1.11 ACCURACY OF CALCULATIONS

In the design of concrete structures, exact calculations to determine the size of the concrete elements are not needed. Calculators and computers can give an answer to many figures after the decimal point. For a practical size of a beam, slab, or column, each dimension should be approximated to the nearest 1 or  $\frac{1}{2}$  in. Moreover, the steel bars available in the market are limited to specific diameters and areas, as shown in Table 1, Appendix 1. The designer should choose a group of bars from the table with an area equal to or greater than the area obtained from calculations. Also, the design equations in this book based on the ACI Code are approximate. Therefore, for a practical and economical design, it is adequate to use four figures (or the full number with no fractions if it is greater than four figures) for the calculation of forces, stresses, moments, or dimensions such as length or width of a section. For strains, use five or six figures because strains are very small quantities measured in a millionth of an inch (e.g., a strain of 0.000358 in./in.). Stresses are obtained by multiplying the strains by the modulus of elasticity of the material, which has a high magnitude (e.g., 29,000,000 lb/in.<sup>2</sup>) for steel. Any figures less than five or six figures in strains will produce quite a change in stresses.

#### *Examples*

For forces, use 28.45 K, 2845 lb, 567.8 K (four figures).

For force/length, use 2.451 K/ft or 2451 lb/ft.

For length or width, use 14.63 in., 1.219 ft (or 1.22 ft).

For areas, use 7.537 in.<sup>2</sup>, and for volumes, use 48.72 in.<sup>3</sup>.

For strains, use 0.002078.

### 1.12 CONCRETE HIGH-RISE BUILDINGS

High-rise buildings are becoming the dominant feature of many U.S. cities; a great number of these buildings are designed and constructed in structural concrete.

Although at the beginning of the century the properties of concrete and joint behavior of steel and concrete were not fully understood, a 16-story building, the Ingalls Building, was constructed

**Table 1.3** Examples of Reinforced Concrete Skyscrapers

Year	Structure	Location	Stories	Height	
				ft	m
1965	Lake Point Tower	Chicago	70	645	197
1969	One Shell Plaza	Houston	52	714	218
1975	Peachtree Center Plaza Hotel	Atlanta	71	723	220
1976	Water Tower Place	Chicago	74	859	262
1976	CN Tower	Toronto	—	1465	447
1977	Renaissance Center Westin Hotel	Detroit	73	740	226
1983	City Center	Minneapolis	40	528	158

in Cincinnati in 1902 with a total height of 210 ft (64 m). In 1922, the Medical Arts Building, with a height of 230 ft (70 m), was constructed in Dallas, Texas. The design of concrete buildings was based on elastic theory concepts and a high factor of safety, resulting in large concrete sections in beams and columns. After extensive research, high-strength concrete and high-strength steel were allowed in the design of reinforced concrete members. Consequently, small concrete sections as well as savings in materials were achieved, and new concepts of structural design were possible.

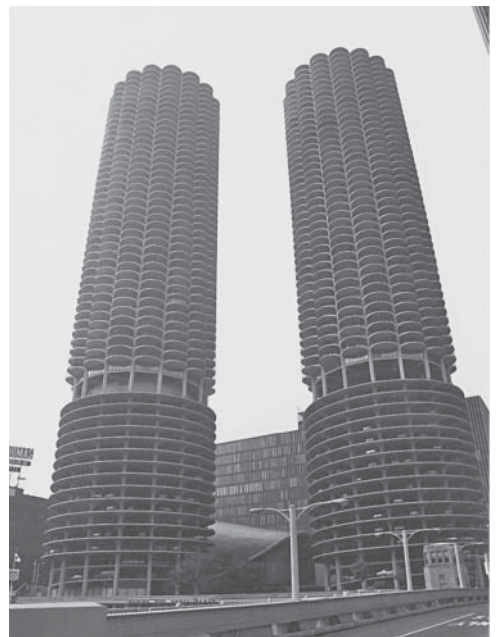
To visualize how high concrete buildings can be built, some structural concrete skyscrapers are listed in Table 1.3. The CN Tower is the world's tallest free-standing concrete structure.

The reader should realize that most concrete buildings are relatively low and range from one to five stories. Skyscrapers and high-rise buildings constitute less than 10% of all concrete buildings.

Photos of some different concrete buildings and structures are shown here.



Renaissance Center, Detroit, Michigan.



Marina City Towers, Chicago, Illinois.



City Center, Minneapolis, Minnesota.

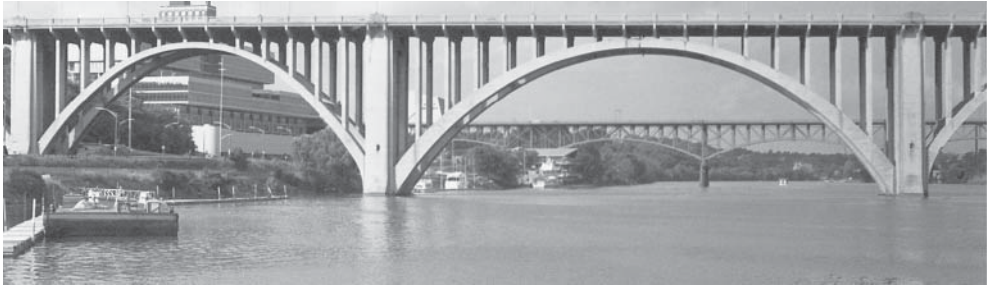


CN Tower, Toronto, Canada (height 1465 ft, or 447 m).



Concrete bridge for the city transit system, Washington, D.C.





Concrete bridge, Knoxville, Tennessee.



Reinforced concrete grain silo using the slip form system. Brookings, South Dakota.

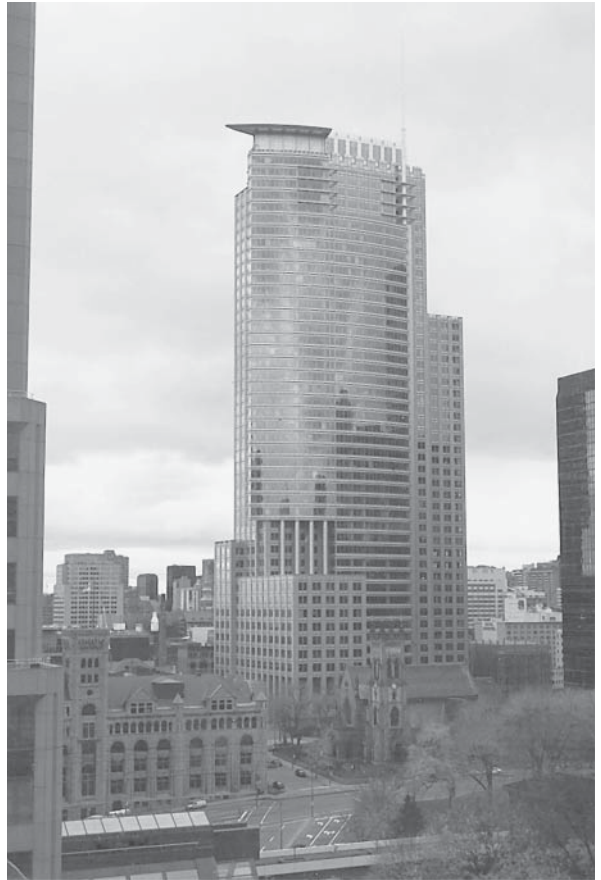
## REFERENCES

1. A. Ra'afat. *The Art of Architecture and Reinforced Concrete*. Halabi, Cairo, 1970.
2. R. S. Kirby, S. Withington, A. B. Darling, and F. G. Kilgour. *Engineering in History*. McGraw-Hill, New York, 1956.
3. H. Straub. *A History of Civil Engineering*. Leonard Hill, London, 1952.
4. E. Freyssinet. *The Birth of Prestressing*. Translation No. 29. Cement and Concrete Association, London, 1956.

5. ANSI A58.1. American National Standards Institute.
6. American Association of State and Highway Transportation officials (AASHTO). *LRFD Bridge Design Specifications*, 7th ed. AASHTO, Washington, DC, 2014.
7. *Specifications for Steel Railway Bridges*. American Railway Engineering Association, Chicago, IL, 1992.
8. C. W. Pinkham and W. C. Hansell. “An Introduction to Load and Resistance Factor Design for Steel Buildings.” *Engineering Journal AISC* 15 (1978, first quarter).

## CHAPTER 2

# PROPERTIES OF REINFORCED CONCRETE



IBM Building, Montreal Canada (the highest concrete building in Montreal, with 50 stories).

### 2.1 FACTORS AFFECTING STRENGTH OF CONCRETE

In general, concrete consists of coarse and fine aggregate, cement, water, and—in many cases—different types of admixture. The materials are mixed together until a cement paste is developed, filling most of the voids in the aggregates and producing a uniform dense concrete. The plastic concrete is then placed in a mold and left to set, harden, and develop adequate strength. For the design of concrete mixtures, as well as composition and properties of concrete materials, the reader is referred to Refs. 1 through 6.

The strength of concrete depends upon many factors and may vary within wide limits with the same production method. The main factors that affect the strength of concrete are described next.

#### 2.1.1 Water–Cement Ratio

The water–cement ratio is one of the most important factors affecting the strength of concrete. For complete hydration of a given amount of cement, a water–cement ratio (by weight) equal to 0.25 is needed. A water–cement ratio of about 0.35 or higher is needed for the concrete to be reasonably workable without additives. This ratio corresponds to 4 gal of water per sack of cement (94 lb) (or 17.8 lb per 50 kg of cement). Based on this cement ratio, a concrete strength of about 6000 psi may be achieved. A water–cement ratio of 0.5 and 0.7 may produce a concrete strength of about 5000 and 3000 psi, respectively.

### 2.1.2 Properties and Proportions of Concrete Constituents

Concrete is a mixture of cement, aggregate, and water. An increase in the cement content in the mix and the use of well-graded aggregate increase the strength of concrete. Special admixtures are usually added to the mix to produce the desired quality and strength of concrete.

### 2.1.3 Method of Mixing and Curing

The use of mechanical concrete mixers and the proper time of mixing both have favorable effects on strength of concrete. Also, the use of vibrators produces dense concrete with a minimum percentage of voids. A void ratio of 5% may reduce the concrete strength by about 30%.

The curing conditions exercise an important influence on the strength of concrete. Both moisture and temperature have a direct effect on the hydration of cement. The longer the period of moist storage, the greater the strength. If the curing temperature is higher than the initial temperature of casting, the resulting 28-day strength of concrete is reached earlier than 28 days.

### 2.1.4 Age of Concrete

The strength of concrete increases appreciably with age, and hydration of cement continues for months. In practice, the strength of concrete is determined from cylinders or cubes tested at the age of 7 and 28 days. As a practical assumption, concrete at 28 days is 1.5 times as strong as at 7 days: The range varies between 1.3 and 1.7. The British Code of Practice [2] accepts concrete if the strength at 7 days is not less than two-thirds of the required 28-day strength. For a normal portland cement, the increase of strength with time, relative to 28-day strength, may be assumed as follows:

Age	7 days	14 days	28 days	3 months	6 months	1 year	2 years	5 years
Strength ratio	0.67	0.86	1.0	1.17	1.23	1.27	1.31	1.35

### 2.1.5 Loading Conditions

The compressive strength of concrete is estimated by testing a cylinder or cube to failure in a few minutes. Under sustained loads for years, the compressive strength of concrete is reduced by about 30%. Under 1 day sustained loading, concrete may lose about 10% of its compressive strength. Sustained loads and creep effect as well as dynamic and impact effect, if they occur on the structure, should be considered in the design of reinforced concrete members.

### 2.1.6 Shape and Dimensions of Tested Specimen

The common sizes of concrete specimens used to predict the compressive strength are either 6 × 12-in. (150 × 300-mm) or 4 × 8-in. (100 × 200-mm) cylinders or 6-in. (150-mm) cubes. When a given concrete is tested in compression by means of cylinders of like shape but of different sizes, the larger specimens give lower strength indexes. Table 2.1 [4] gives the relative strength for various sizes of cylinders as a percentage of the strength of the standard cylinder; the heights of all cylinders are twice the diameters.

Sometimes concrete cylinders of nonstandard shape are tested. The greater the ratio of specimen height to diameter, the lower the strength indicated by the compression test. To compute the equivalent strength of the standard shape, the results must be multiplied by a correction factor. Approximate values of the correction factor are given in Table 2.2, extracted from ASTM C 42/C 42 M. The relative strengths of a cylinder and a cube for different compressive strengths are shown in Table 2.3.

**Table 2.1** Effect of Size of Compression Specimen on Strength of Concrete

Size of Cylinder		Relative Compressive Strength
in.	mm	
2 × 4	50 × 100	1.09
3 × 6	75 × 150	1.06
6 × 12	150 × 300	1.00
8 × 16	200 × 400	0.96
12 × 24	300 × 600	0.91
18 × 36	450 × 900	0.86
24 × 48	600 × 1200	0.84
36 × 72	900 × 1800	0.82

**Table 2.2** Strength Correction Factor for Cylinders of Different Height–Diameter Ratios

Ratio	2.0	1.75	1.50	1.25	1.10	1.00	0.75	0.50
Strength correction factor	1.00	0.98	0.96	0.93	0.90	0.87	0.70	0.50
Strength relative to standard cylinder	1.00	1.02	1.04	1.06	1.11	1.18	1.43	2.00

**Table 2.3** Relative Strength of Cylinder versus Cube [6]

Compressive strength	(psi)	1000	2200	2900	3500	3800	4900	5300	5900	6400	7300
	(N/mm <sup>2</sup> )	7.0	15.5	20.0	24.5	27.0	24.5	37.0	41.5	45.0	51.5
Strength ratio of cylinder to cube		0.77	0.76	0.81	0.87	0.91	0.93	0.94	0.95	0.96	0.96

## 2.2 COMPRESSIVE STRENGTH

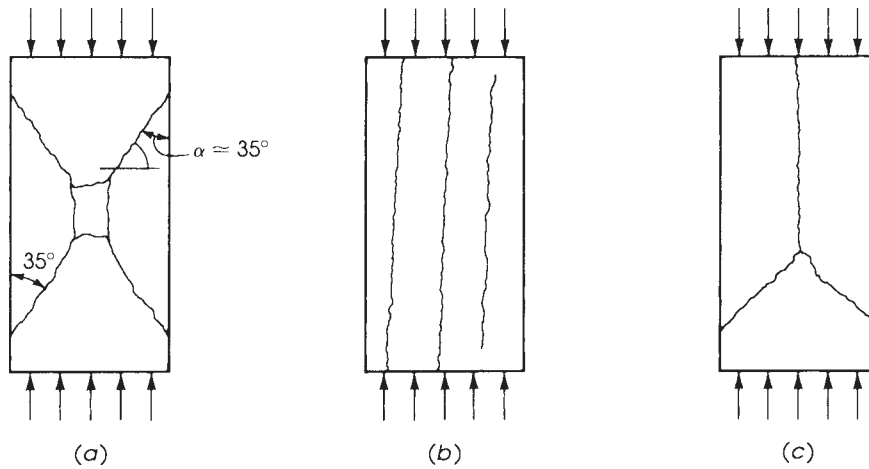
In designing structural members, it is assumed that the concrete resists compressive stresses and not tensile stresses; therefore, compressive strength is the criterion of quality concrete. The other concrete stresses can be taken as a percentage of the compressive strength, which can be easily and accurately determined from tests. Specimens used to determine compressive strength may be cylindrical, cubical, or prismatic.

Test specimens in the form of a 6-in. (150-mm) or 8-in. (200-mm) cube are used in Great Britain, Germany, and other parts of Europe.

Prism specimens are used in France, Russia, and other countries and are usually 70 × 70 × 350 mm or 100 × 100 × 500 mm. They are cast with their longer sides horizontal and are tested, like cubes, in a position normal to the position of cast.

Before testing, the specimens are moist cured and then tested at the age of 28 days by gradually applying a static load until rupture occurs. The rupture of the concrete specimen may be caused by the applied tensile stress (failure in cohesion), the applied shearing stress (sliding failure), the compressive stress (crushing failure), or combinations of these stresses.

The failure of the concrete specimen can be in one of three modes [5], as shown in Fig. 2.1. First, under axial compression, the specimen may fail in shear, as in Fig. 2.1a. Resistance to failure is due to both cohesion and internal friction.



**Figure 2.1** Modes of failure of standard concrete cylinders.

The second type of failure (Fig. 2.1*b*) results in the separation of the specimen into columnar pieces by what is known as splitting, or columnar, fracture. This failure occurs when the strength of concrete is high, and lateral expansion at the end bearing surfaces is relatively unrestrained.

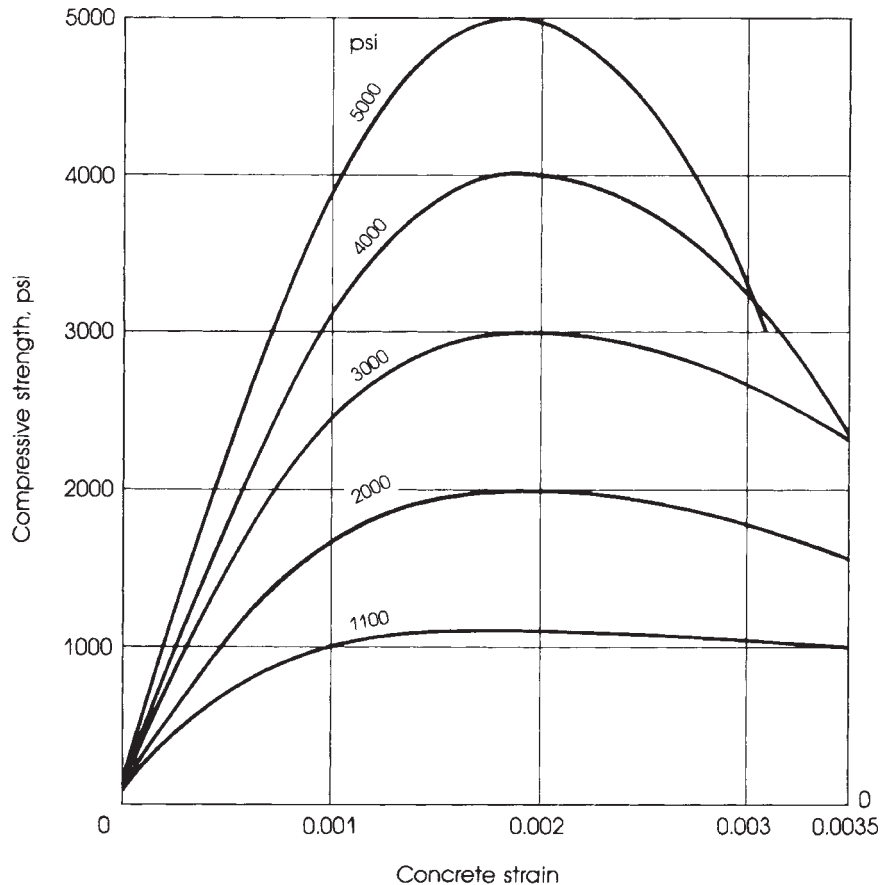
The third type of failure (Fig. 2.1*c*) is seen when a combination of shear and splitting failure occurs.

### 2.3 STRESS-STRAIN CURVES OF CONCRETE

The performance of a reinforced concrete member under load depends, to a great extent, on the stress-strain relationship of concrete and steel and on the type of stress applied to the member. Stress-strain curves for concrete are obtained by testing a concrete cylinder to rupture at the age of 28 days and recording the strains at different load increments.



Standard capped cylinders ready for testing.



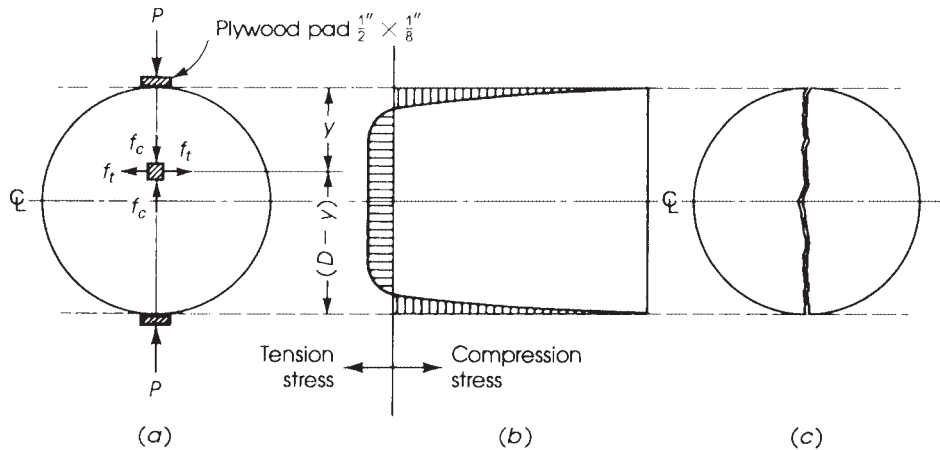
**Figure 2.2** Typical stress–strain curves of concrete.

Figure 2.2 shows typical stress–strain curves for concretes of different strengths. All curves consist of an initial relatively straight elastic portion, reaching maximum stress at a strain of about 0.002; then rupture occurs at a strain of about 0.003. Concrete having a compressive strength between 3000 and 6000 psi (21 and 42 N/mm<sup>2</sup>) may be adopted. High-strength concrete with a compressive strength greater than 6000 psi (6000 to 15,000 psi) is becoming an important building material for the design of concrete structures.

## 2.4 TENSILE STRENGTH OF CONCRETE

Concrete is a brittle material, and it cannot resist the high tensile stresses that are important when considering cracking, shear, and torsional problems. The low tensile capacity can be attributed to the high stress concentrations in concrete under load, so that a very high stress is reached in some portions of the specimen, causing microscopic cracks, while the other parts of the specimen are subjected to low stress.

Direct tension tests are not reliable for predicting the tensile strength of concrete, due to minor misalignment and stress concentrations in the gripping devices. An indirect tension test in



**Figure 2.3** Cylinder splitting test [6]: (a) configuration of test, (b) distribution of horizontal stress, and (c) cylinder after testing.

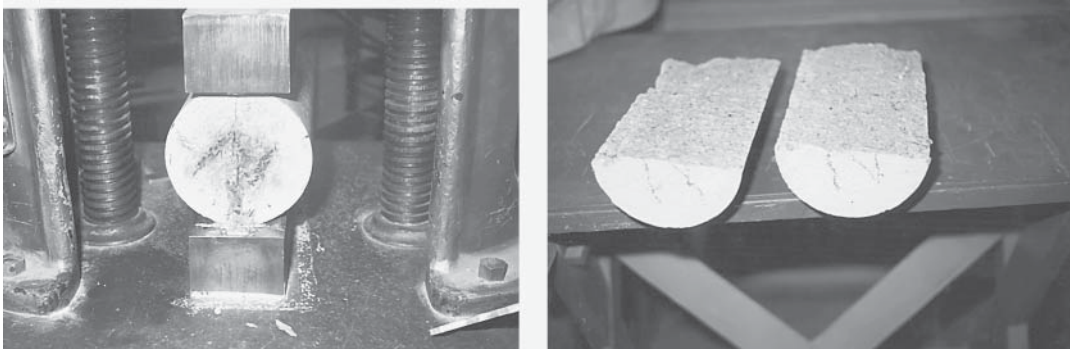
the form of splitting a  $6 \times 12$ -in. ( $150 \times 300$ -mm) cylinder was suggested by the Brazilian Fernando Carneiro. The test is usually called the *splitting test*. In this test, the concrete cylinder is placed with its axis horizontal in a compression testing machine. The load is applied uniformly along two opposite lines on the surface of the cylinder through two plywood pads, as shown in Fig. 2.3. Considering an element on the vertical diameter and at a distance  $y$  from the top fibers, the element is subjected to a compressive stress

$$f_c = \frac{2P}{\pi LD} \left( \frac{D^2}{y(D-y)} - 1 \right) \quad (2.1)$$

and a tensile stress

$$f'_{sp} = \frac{2P}{\pi LD} \quad (2.2)$$

where  $P$  is the compressive load on the cylinder and  $D$  and  $L$  are the diameter and length of the cylinder. For a  $6 \times 12$ -in. ( $150 \times 300$ -mm) cylinder and at a distance  $y = D/2$ , the compression strength is  $f_c = 0.0265 P$ , and the tensile strength is  $f'_{sp} = 0.0088P = f_c/3$ .



Concrete cylinder splitting test.



The splitting strength of  $f'_{sp}$  can be related to the compressive strength of concrete in that it varies between six and seven times  $\sqrt{f'_c}$  for normal concrete and between four and five times  $\sqrt{f'_c}$  for lightweight concrete. The direct tensile stress,  $f'_t$ , can also be estimated from the split test: Its value varies between  $0.5f'_{sp}$  and  $0.7f'_{sp}$ . The smaller of these values applies to higher strength concrete. The splitting strength,  $f'_{sp}$ , can be estimated as 10% of the compressive strength up to  $f'_c = 6000$  psi (42 N/mm<sup>2</sup>). For higher values of compressive strength,  $f'_{sp}$  can be taken as 9% of  $f'_c$ .

In general, the tensile strength of concrete ranges from 7 to 11% of its compressive strength, with an average of 10%. The lower the compressive strength, the higher the relative tensile strength.

## 2.5 FLEXURAL STRENGTH (MODULUS OF RUPTURE) OF CONCRETE

Experiments on concrete beams have shown that tensile strength in bending is greater than the tensile stress obtained by direct or splitting tests. Flexural strength is expressed in terms of the modulus of rupture of concrete ( $f_r$ ), which is the maximum tensile stress in concrete in bending. The modulus of rupture can be calculated from the flexural formula used for elastic materials,  $f_r = Mc/I$ , by testing a plain concrete beam. The beam, 6 × 6 × 28 in. (150 × 150 × 700 mm), is supported on a 24-in. (600-mm) span and loaded to rupture by two loads, 4 in. (100 mm) on either side of the center. A smaller beam of 4 × 4 × 20 in. (100 × 100 × 500 mm) on a 16-in. (400-mm) span may also be used.

The modulus of rupture of concrete ranges between 11 and 23% of the compressive strength. A value of 15% can be assumed for strengths of about 4000 psi (28 N/mm<sup>2</sup>). The ACI Code, Section 19.2.3.1, prescribes the value of the modulus of rupture as

$$f_r = 7.5\lambda\sqrt{f'_c} \text{ (psi)} = 0.62\lambda\sqrt{f'_c} \text{ (N/mm}^2\text{)} \quad (2.3)$$

where the modification factor  $\lambda$  for type of concrete (ACI Table 19.2.4.2) is given as

$$\lambda = \begin{cases} 1.0 & \text{for normal-weight concrete} \\ 0.85 & \text{for sand - lightweight concrete} \\ 0.75 & \text{for all - lightweight concrete} \end{cases}$$

Linear interpolation shall be permitted between 0.85 and 1.0 on the basis of volumetric fractions, for concrete containing normal-weight fine aggregate and a blend of lightweight and normal-weight coarse aggregate.

The modulus of rupture as related to the strength obtained from the split test on cylinders may be taken as  $f_r = (1.25 \text{ to } 1.50)f'_{sp}$ .

## 2.6 SHEAR STRENGTH

Pure shear is seldom encountered in reinforced concrete members because it is usually accompanied by the action of normal forces. An element subjected to pure shear breaks transversely into two parts. Therefore, the concrete element must be strong enough to resist the applied shear forces.

Shear strength may be considered as 20 to 30% greater than the tensile strength of concrete, or about 12% of its compressive strength. The ACI Code, Section 22.6.6.1, allows a nominal shear stress of  $2\lambda\sqrt{f'_c}$  psi ( $0.17\lambda\sqrt{f'_c}$  N/mm<sup>2</sup>) on plain concrete sections. For more information, refer to Chapter 5.

## 2.7 MODULUS OF ELASTICITY OF CONCRETE

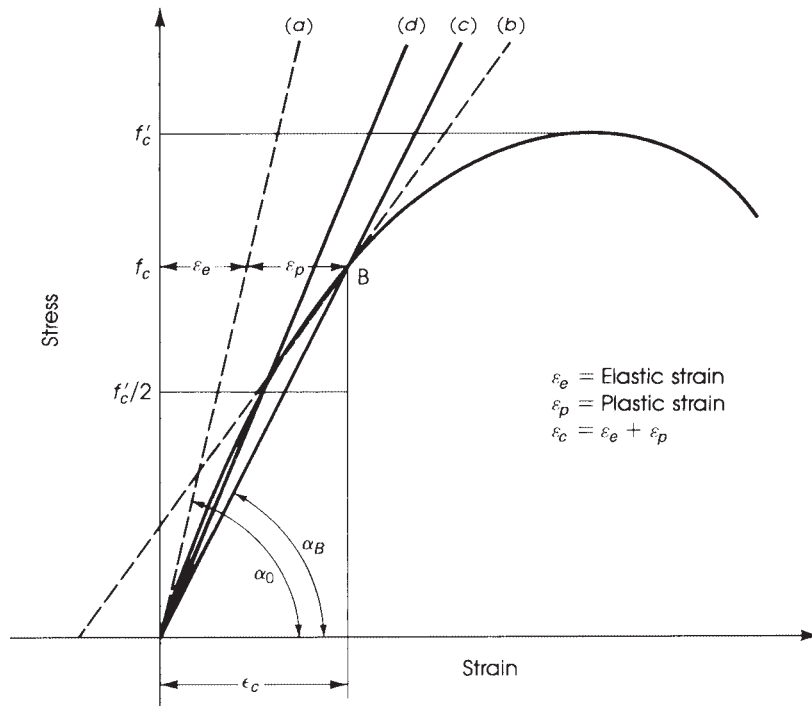
One of the most important elastic properties of concrete is its modulus of elasticity, which can be obtained from a compressive test on concrete cylinders. The modulus of elasticity,  $E_c$ , can be defined as the change of stress with respect to strain in the elastic range:

$$E_c = \frac{\text{unitstress}}{\text{unitstrain}} \quad (2.4)$$

The modulus of elasticity is a measure of stiffness, or the resistance of the material to deformation. In concrete, as in any elastoplastic material, the stress is not proportional to the strain, and the stress–strain relationship is a curved line. The actual stress–strain curve of concrete can be obtained by measuring the strains under increments of loading on a standard cylinder.

The *initial tangent modulus* (Fig. 2.4) is represented by the slope of the tangent to the curve at the origin under elastic deformation. This modulus is of limited value and cannot be determined with accuracy. Geometrically, the tangent modulus of elasticity of concrete,  $E_c$ , is the slope of the tangent to the stress–strain curve at a given stress. Under long-time action of load and due to the development of plastic deformation, the stress-to-total-strain ratio becomes a variable nonlinear quantity.

$$E_c = \frac{df_c}{d\varepsilon_c}$$



**Figure 2.4** Stress–strain curve and modulus of elasticity of concrete. Lines *a–d* represent (a) initial tangent modulus, (b) tangent modulus at a stress,  $f_c$ , (c) secant modulus at a stress,  $f_c$ , and (d) secant modulus at a stress  $f'_c/2$ .

For practical applications, the *secant modulus* can be used. The secant modulus is represented by the slope of a line drawn from the origin to a specific point of stress ( $B$ ) on the stress–strain curve (Fig. 2.4). Point  $B$  is normally located at  $f'_c/2$ .

The ACI Code, Section 19.2.2.1, gives a simple formula for calculating the modulus of elasticity of normal and lightweight concrete considering the secant modulus at a level of stress,  $f'_c$ , equal to half the specified concrete strength,  $f'_c$ ,

$$E_c = 33w^{1.5} \sqrt{f'_c} \text{ psi} (w \text{ in pcf}) = 0.043w^{1.5} \sqrt{f'_c} \text{ N/mm}^2 \quad (2.5)$$

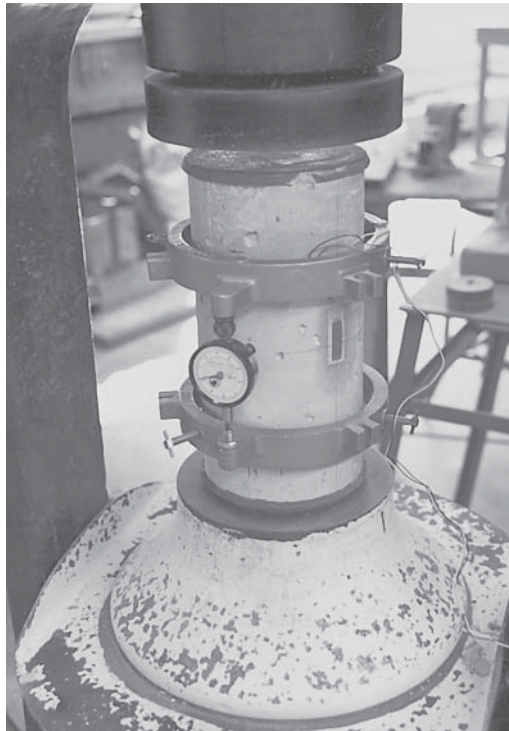
where  $w$  = unit weight of concrete [between 90 and 160 lb/ft<sup>3</sup> (pcf) or 1400 to 2600 kg/m<sup>3</sup>] and  $f'_c$  = specified compressive strength of a standard concrete cylinder. For normal-weight concrete,  $w$  is approximately 145 pcf (2320 kg/m<sup>3</sup>); thus,

$$E_c = 57,600 \sqrt{f'_c} \text{ psi} = 4780 \sqrt{f'_c} \text{ MPa} \quad (2.6)$$

The ACI Code allows the use of  $E_c = 57,000 \sqrt{f'_c}$  (psi) = 4700  $\sqrt{f'_c}$  MPa. The module of elasticity,  $E_c$ , for different values of  $f'_c$  are shown in Table A.10.

## 2.8 POISSON'S RATIO

Poisson's ratio  $\mu$  is the ratio of the transverse to the longitudinal strains under axial stress within the elastic range. This ratio varies between 0.15 and 0.20 for both normal and lightweight concrete. Poisson's ratio is used in structural analysis of flat slabs, tunnels, tanks, arch dams, and other statically indeterminate structures. For isotropic elastic materials, Poisson's ratio is equal to 0.25. An average value of 0.18 can be used for concrete.



Test on a standard concrete cylinder to determine the modulus of elasticity of concrete.

## 2.9 SHEAR MODULUS

The modulus of elasticity of concrete in shear ranges from about 0.4 to 0.6 of the corresponding modulus in compression. From the theory of elasticity, the shear modulus is taken as follows:

$$G_c = \frac{E_c}{2(1 + \mu)} \quad (2.7)$$

where  $\mu$  = Poisson's ratio of concrete. If  $\mu$  is taken equal to  $\frac{1}{6}$ , then  $G_c = 0.43E_c = 24,500\sqrt{f'_c}$ .

## 2.10 MODULAR RATIO

The modular ratio  $n$  is the ratio of the modulus of elasticity of steel to the modulus of elasticity of concrete:  $n = E_s/E_c$ .

Because the modulus of elasticity of steel is considered constant and is equal to  $29 \times 10^6$  psi and  $E_c = 33w^{1.5}\sqrt{f'_c}$ ,

$$n = \frac{29 \times 10^6}{33w^{1.5}\sqrt{f'_c}} \quad (2.8)$$

For normal-weight concrete,  $E_c = 57,000\sqrt{f'_c}$ ; hence,  $n$  can be taken as

$$n = \frac{500}{\sqrt{f'_c}}(f'_c \text{ in psi}) = \frac{42}{\sqrt{f'_c}}(f'_c \text{ in N/mm}^2) \quad (2.9)$$

The significance and the use of the modular ratio are explained in Chapter 6.

## 2.11 VOLUME CHANGES OF CONCRETE

Concrete undergoes volume changes during hardening. If it loses moisture by evaporation, it shrinks, but if the concrete hardens in water, it expands. The causes of the volume changes in concrete can be attributed to changes in moisture content, chemical reaction of the cement with water, variation in temperature, and applied loads.

### 2.11.1 Shrinkage

The change in the volume of drying concrete is not equal to the volume of water removed [6]. The evaporation of free water causes little or no shrinkage. As concrete continues to dry, water evaporates and the volume of the restrained cement paste changes, causing concrete to shrink, probably due to the capillary tension that develops in the water remaining in concrete. Emptying of the capillaries causes a loss of water without shrinkage, but once the absorbed water is removed, shrinkage occurs.

Many factors influence the shrinkage of concrete caused by the variations in moisture conditions [5]:

1. *Cement and Water Content.* The more cement or water content in the concrete mix, the greater the shrinkage.
2. *Composition and Fineness of Cement.* High-early-strength and low-heat cements show more shrinkage than normal portland cement. The finer the cement, the greater the expansion under moist conditions.

3. *Type, Amount, and Gradation of Aggregate.* The smaller the size of aggregate particles, the greater the shrinkage. The greater the aggregate content, the smaller the shrinkage [7].
4. *Ambient Conditions, Moisture, and Temperature.* Concrete specimens subjected to moist conditions undergo an expansion of  $200$  to  $300 \times 10^{-6}$ , but if they are left to dry in air, they shrink. High temperature speeds the evaporation of water and, consequently, increases shrinkage.
5. *Admixtures.* Admixtures that increase the water requirement of concrete increase the shrinkage value.
6. *Size and Shape of Specimen.* As shrinkage takes place in a reinforced concrete member, tension stresses develop in the concrete, and equal compressive stresses develop in the steel. These stresses are added to those developed by the loading action. Therefore, cracks may develop in concrete when a high percentage of steel is used. Proper distribution of reinforcement, by producing better distribution of tensile stresses in concrete, can reduce differential internal stresses.

The values of final shrinkage for ordinary concrete vary between  $200$  and  $700 \times 10^{-6}$ . For normal-weight concrete, a value of  $300 \times 10^{-6}$  may be used. The British Code [8] gives a value of  $500 \times 10^{-6}$ , which represents an unrestrained shrinkage of  $1.5$  mm in a  $3$ -m length of thin, plain concrete sections. If the member is restrained, a tensile stress of about  $10$  N/mm<sup>2</sup> ( $1400$  psi) arises. If concrete is kept moist for a certain period after setting, shrinkage is reduced; therefore, it is important to cure the concrete for a period of no fewer than  $7$  days.

Exposure of concrete to wind increases the shrinkage rate on the upwind side. Shrinkage causes an increase in the deflection of structural members, which in turn increases with time. Symmetrical reinforcement in the concrete section may prevent curvature and deflection due to shrinkage.

Generally, concrete shrinks at a high rate during the initial period of hardening, but at later stages the rate diminishes gradually. It can be said that  $15$  to  $30\%$  of the shrinkage value occurs in  $2$  weeks,  $40$  to  $80\%$  occurs in  $1$  month, and  $70$  to  $85\%$  occurs in  $1$  year.

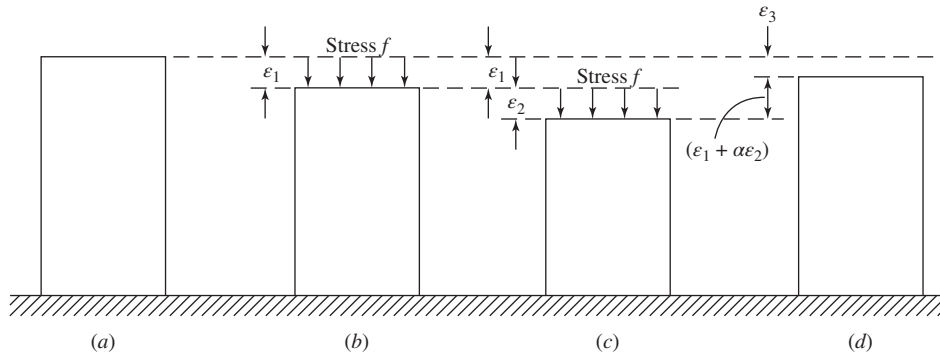
### 2.11.2 Expansion Due to Rise in Temperature

Concrete expands with increasing temperature and contracts with decreasing temperature. The coefficient of thermal expansion of concrete varies between  $4$  and  $7 \times 10^{-6}$  per degree Fahrenheit. An average value of  $5.5 \times 10^{-6}$  per degree Fahrenheit ( $12 \times 10^{-6}$  per degree Celsius) can be used for ordinary concrete. The British Standard Institution [8] suggests a value of  $10^{-5}$  per degree Celsius. This value represents a change of length of  $10$  mm in a  $30$ -m member subjected to a change in temperature of  $33^\circ\text{C}$ . If the member is restrained and unreinforced, a stress of about  $7$  N/mm<sup>2</sup> ( $1000$  psi) may develop.

In long reinforced concrete structures, expansion joints must be provided at lengths of  $100$  to  $200$  ft ( $30$  to  $60$  m). The width of the expansion joint is about  $1$  in. ( $25$  mm). Concrete is not a good conductor of heat, whereas steel is a good one. The ability of concrete to carry load is not much affected by temperature.

## 2.12 CREEP

Concrete is an elastoplastic material, and beginning with small stresses, plastic strains develop in addition to elastic ones. Under sustained load, plastic deformation continues to develop over a period that may last for years. Such deformation increases at a high rate during the first  $4$  months after application of the load. This slow plastic deformation under constant stress is called *creep*.



**Figure 2.5** Deformation in a loaded concrete cylinder: (a) specimen unloaded, (b) elastic deformation, (c) elastic plus creep deformation, and (d) permanent deformation after release of load.

Figure 2.5 shows a concrete cylinder that is loaded. The instantaneous deformation is  $\epsilon_1$ , which is equal to the stress divided by the modulus of elasticity. If the same stress is kept for a period of time, an additional strain,  $\epsilon_2$ , due to creep effect, can be recorded. If load is then released, the elastic strain,  $\epsilon_1$ , will be recovered, in addition to some creep strain. The final permanent plastic strain,  $\epsilon_3$ , will be left, as shown in Fig. 2.5. In this case,  $\epsilon_3 = (1 - \alpha)\epsilon_2$ , where  $\alpha$  is the ratio of the recovered creep strain to the total creep strain. The ratio  $\alpha$  ranges between 0.1 and 0.2. The magnitude of creep recovery varies with the previous creep and depends appreciably upon the period of the sustained load. Creep recovery rate will be less if the loading period is increased, probably due to the hardening of concrete while in a deformed condition.

The ultimate magnitude of creep varies between  $0.2 \times 10^{-6}$  and  $2 \times 10^{-6}$  per unit stress (lb/in.<sup>2</sup>) per unit length. A value of  $1 \times 10^{-6}$  can be used in practice. The ratio of creep strain to elastic strain may be as high as 4.

Creep takes place in the hardened cement matrix around the strong aggregate. It may be attributed to slippage along planes within the crystal lattice, internal stresses caused by changes in the crystal lattice, and gradual loss of water from the cement gel in the concrete.

The different factors that affect the creep of concrete can be summarized as follows [9]:

1. *Level of Stress.* Creep increases with an increase of stress in specimens made from concrete of the same strength and with the same duration of load.
2. *Duration of Loading.* Creep increases with the loading period. About 80% of the creep occurs within the first 4 months; 90% occurs after about 2 years.
3. *Strength and Age of Concrete.* Creep tends to be smaller if concrete is loaded at a late age. Also, creep of 2000 psi (14 N/mm<sup>2</sup>)-strength concrete is about  $1.41 \times 10^{-6}$ , whereas that of 4000 psi (28 N/mm<sup>2</sup>)-strength concrete is about  $0.8 \times 10^{-6}$  per unit stress and length of time.
4. *Ambient Conditions.* Creep is reduced with an increase in the humidity of the ambient air.
5. *Rate of Loading.* Creep increases with an increase in the rate of loading when followed by prolonged loading.
6. *Percentage and Distribution of Steel Reinforcement in Reinforced Concrete Member.* Creep tends to be smaller for higher proportion or better distribution of steel.
7. *Size of Concrete Mass.* Creep decreases with an increase in the size of the tested specimen.

8. *Type, Fineness, and Content of Cement.* The amount of cement greatly affects the final creep of concrete, as cement creeps about 15 times as much as concrete.
9. *Water–Cement Ratio.* Creep increases with an increase in the water–cement ratio.
10. *Type and Grading of Aggregate.* Well-graded aggregate will produce dense concrete and consequently a reduction in creep.
11. *Type of Curing.* High-temperature steam curing of concrete, as well as the proper use of a plasticizer, will reduce the amount of creep.

Creep develops not only in compression but also in tension, bending, and torsion.

The ratio of the rate of creep in tension to that in compression will be greater than 1 in the first 2 weeks, but this ratio decreases over longer periods [5].

Creep in concrete under compression has been tested by many investigators. Troxell, Raphale, and Davis [10] measured creep strains periodically for up to 20 years and estimated that of the total creep after 20 years, 18 to 35% occurred in 2 weeks, 30 to 70% occurred in 3 months, and 64 to 83% occurred in 1 year.

For normal concrete loaded after 28 days,  $C_r = 0.13\sqrt[3]{t}$ , where  $C_r$  = creep strain per unit stress per unit length. Creep augments the deflection of reinforced concrete beams appreciably with time. In the design of reinforced concrete members, long-term deflection may be critical and has to be considered in proper design. Extensive deformation may influence the stability of the structure.

Sustained loads affect the strength as well as the deformation of concrete. A reduction of up to 30% of the strength of unreinforced concrete may be expected when concrete is subjected to a concentric sustained load for 1 year.

The fatigue strength of concrete is much smaller than its static strength. Repeated loading and unloading cycles in compression lead to a gradual accumulation of plastic deformations. If concrete in compression is subjected to about 2 million cycles, its fatigue limit is about 50 to 60% of the static compression strength. In beams, the fatigue limit of concrete is about 55% of its static strength [11].

## 2.13 MODELS FOR PREDICTING SHRINKAGE AND CREEP OF CONCRETE

Seven models were described in this chapter for the prediction of shrinkage and creep of concrete. These include ACI 209R-92, B3, GL-2000, CEB 90, CEB MC 90–99, fib MC 2010, and AASHTO.

### 2.13.1 ACI 209R-92 Model

The American Concrete Institute recommends the ACI 209R-92 as one of four models [12]. Branson and Christianson [13] first developed this model in 1970. The ACI 209 model was used for many years in the design of concrete structures. The model is simple to use but limited in its accuracy.

**Shrinkage Calculation.** Calculation of shrinkage using the ACI 209R-92 model can be performed if the following parameters and conditions are known: curing method (moist-cured or steam-cured concrete), relative humidity,  $H$ , type of cement, specimen shape, ultimate shrinkage strain,  $\epsilon_{shu}$ , age of concrete after casting,  $t$ , age of the concrete drying commenced, usually taken as the age at the end of moist curing,  $t_c$ .

The shrinkage strain is defined as

$$\epsilon_{sh}(t, t_c) = \frac{t - t_c}{f + (t - t_c)} K_{ss} K_{sh} \epsilon_{shu} \quad (2.10)$$

where

- $t$  = age of concrete after casting (days)  
 $t_c$  = age of the concrete drying commenced (days)  
 $f$  = constant in determining shrinkage strain, depends on curing method shape and size factors according to Table 2.4  
 $K_{ss}$  = shape and size correction factor for shrinkage according to Eq. 2.11  
 $K_{sh}$  = relative humidity correction factor for shrinkage according to Eq. 2.12  
 $\epsilon_{shu}$  = ultimate shrinkage strain  $780 \times 10^{-6}$  (in./in.) or (mm/mm) (for both moist- and steam-cured concrete)

Shape and size correction factor for shrinkage should be calculated as follows:

For  $t - t_c \leq$  one year

$$K_{ss} = \begin{cases} 1.23 - 0.152 \left( \frac{V}{S} \right) & \text{(in. - lb)} \\ 1.23 - 0.006 \left( \frac{V}{S} \right) & \text{(SI)} \end{cases} \quad (2.11a)$$

For  $t - t_c >$  one year

$$K_{ss} = \begin{cases} 1.17 - 0.116 \left( \frac{V}{S} \right) & \text{(in. - lb)} \\ 1.17 - 0.00456 \left( \frac{V}{S} \right) & \text{(SI)} \end{cases} \quad (2.11b)$$

where

- $V$  = volume of the specimen (in.<sup>3</sup> or mm<sup>3</sup>)  
 $S$  = surface of the specimen (in.<sup>2</sup> or mm<sup>2</sup>)

Relative humidity correction factor for shrinkage is

$$K_{sh} = \begin{cases} 1.40 - 0.01H & \text{for } 40\% \leq H \leq 80\% \\ 3.00 - 0.03H & \text{for } 81\% \leq H \leq 100\% \end{cases} \quad (2.12)$$

where

- $H$  = relative humidity (%)

**Table 2.4** Values of Constant  $f$  as a Function of Curing Method

Conditions	$f$
Moist-cured concrete (7 days min.)	35
Steam-cured concrete (3 days min.)	55
If shape and size effects are considered for both curing condition	$26e^{[0.36(V/S)]}$ (in.-lb)
	$26e^{[1.42 \times 10^{-2}(V/S)]}$ (SI)

Note: In practice,  $f = 35$  and  $f = 155$  are commonly used.



**Creep Calculation.** The total load-dependent strain at time  $t$ ,  $\varepsilon_{ic}(t, t_0)$  of a concrete member uniaxially loaded at time  $t_0$  with a constant stress  $\sigma$  may be calculated as follows:

$$\varepsilon_{ic}(t, t_0) = \varepsilon_i(t_0) + \varepsilon_c(t, t_0) \quad (2.13)$$

where

$$\begin{aligned} \varepsilon_i(t_0) &= \text{initial elastic strain at loading} \\ \varepsilon_c(t, t_0) &= \text{creep strain at time } t \geq t_0 \end{aligned}$$

$$\varepsilon_i(t_0) = \frac{\sigma}{E_{cmt_0}} \quad (2.14)$$

$$\varepsilon_c(t, t_0) = \frac{\sigma}{E_{cmt_0}} C_c(t) \quad (2.15)$$

where

$$\begin{aligned} E_{cmt_0} &= \text{modulus of elasticity at age of loading (MPa) as given in Eq. 2.17} \\ C_c(t) &= \text{creep coefficient at time } t, \text{ as given in Eq. 2.19} \end{aligned}$$

Usually, the total load-dependent strain is presented with compliance function, also called creep function,  $J(t, t_0)$ , which represents the total load-dependent strain at time  $t$  produced by a unit constant stress that has been acting since time  $t_0$ .

$$J(t, t_0) = \frac{1 + C_c(t)}{E_{cmt_0}} \quad (2.16)$$

$$E_{cmt_0} = \begin{cases} 33(\gamma)^{3/2} \sqrt{f'_c(t_0)} & (\text{in.} - \text{lb}) \\ 0.043(\gamma)^{3/2} \sqrt{f'_c(t_0)} & (\text{SI}) \end{cases} \quad (2.17)$$

where

$$\begin{aligned} \gamma &= \text{concrete unit weight (kg/m}^3\text{) or (lb/ft}^3\text{)} \\ f'_c(t_0) &= \text{mean concrete compressive strength at age of loading (MPa) or ksi} \end{aligned}$$

$$f'_c(t_0) = f_{cm_{28}} \frac{t_0}{a + bt_0} \quad (2.18)$$

where  $f_{cm_{28}}$  is the average 28-day concrete compressive strength (MPa)  $a$  and  $b$  are constants according to Table 2.5.

Creep coefficient,  $C_c(t)$ , can be determined as follows:

$$C_c(t, t_0) = \frac{(t - t_0)^{0.60}}{10 + (t - t_0)^{0.60}} C_{cu} K_{ch} K_{ca} K_{cs} \quad (2.19)$$

**Table 2.5** Constants  $a$  and  $b$  as Function of Cement Type and Curing Method

Type of Cement	Moist-Cured Concrete		Steam-Cured Concrete	
I	$a = 4$	$b = 0.85$	$a = 1$	$b = 0.95$
III	$a = 2.30$	$b = 0.92$	$a = 0.70$	$b = 0.98$

**Table 2.6** Correction Factors for Age of Loading and Relative Humidity

Curing Method	$t_0$ (days)	$H$	$K_{ca}$	$K_{ch}$
Moist cured	$\geq 1$ day	$\geq 40\%$	N/A	N/A
	$\geq 7$ days	$\geq 40\%$	$1.25(t_0)^{-0.118}$	$1.27 - 0.0067H$
Steam cured	$\geq 1$ day	$\geq 40\%$	$1.13(t_0)^{-0.095}$	$1.27 - 0.0067H$
	$\geq 7$ days	$\geq 40\%$	N/A	N/A

**Table 2.7** Correction Factors for Shape and Size

$t - t_0$	$K_{cs}$ (in. -lb)	$K_{cs}$ (SI)
< 1 year	$1.14 - 0.092 \left(\frac{V}{S}\right)$	$1.14 - 0.00363 \left(\frac{V}{S}\right)$
> 1 year	$1.10 - 0.068 \left(\frac{V}{S}\right)$	$1.10 - 0.00268 \left(\frac{V}{S}\right)$

where

$t_0$  = age of concrete at loading (days)

$t$  = age of concrete (days)

$C_{cu}$  = ultimate creep coefficient = 2.35

$K_{ch}$  = relative humidity correction factor for creep determined from Table 2.6

$K_{ca}$  = age at loading correction factor determined from Table 2.6

$K_{cs}$  = shape and size correction factor for creep determined from Table 2.7

### 2.13.2 B3 Model

The model was developed by Bazant and Baweja [14] and is described by ACI [12].

**Shrinkage Calculation.** Required parameters for calculation of shrinkage strain using the B3 model are concrete mean compressive strength at 28 days, curing conditions, cement type, relative humidity, water content in concrete, and specimen shape.

The shrinkage strain can be estimated using the following equation:

$$\epsilon_s(t) = (\epsilon_{shu})(K_h)S(t) \quad (2.20)$$

where

$\epsilon_{shu}$  = ultimate shrinkage strain according to Eq. 2.21

$K_h$  = humidity function for shrinkage according to Table 2.9

$S(t)$  = time function for shrinkage according to Eq. 22.27

Ultimate shrinkage strain can be calculated using the following equation:

$$\epsilon_{shu} = -\epsilon_{su} \frac{E_{cm607}}{E_{cm(t_c + \tau_{sh})}} \quad (2.21)$$

$$\epsilon_{su} = \begin{cases} -\alpha_1 \alpha_2 [0.025(w)^{2.1} (f_{cm28})^{-0.28} + 270] \times 10^{-6} & \text{(in. - lb)} \\ -\alpha_1 \alpha_2 [0.019(w)^{2.1} (f_{cm28})^{-0.28} + 270] \times 10^{-6} & \text{(SI)} \end{cases} \quad (2.22)$$

**Table 2.8** Correction Factor  $\alpha_1$  as Function of Cement Type

Type of Cement	$\alpha_1$
I	1.00
II	0.85
III	1.10

**Table 2.9** Correction Factor  $\alpha_2$  as Function of Type of Curing

Type of Curing	$\alpha_2$
Steam cured	0.75
Water cured or $H = 100\%$	1.00
Sealed during curing	1.20

where

$\alpha_1$  = type of cement correction factor according to Table 2.8

$\alpha_2$  = curing condition correction factor according to the Table 2.9

$w$  = water content ( $\text{kg}/\text{m}^3$ ) or ( $\text{lb}/\text{yd}^3$ )

$f_{\text{cm}28}$  = mean compressive concrete strength at 28 days (MPa) or (psi)

$E_{\text{cm}607}/E_{\text{cm}(t+\tau_{\text{sh}})}$  = a factor that accounts for the time dependence of ultimate shrinkage of concrete

Type of cement correction factor  $\alpha_1$  can be determined using Table 2.8.

Curing condition correction factor  $\alpha_2$  can be determined using Table 2.9.

Humidity function for shrinkage,  $K_h$ , should be determined according to Table 2.10.

$$E_{\text{cm}28} = \begin{cases} 57000\sqrt{f_{\text{cm}28}} & (\text{in.} - \text{lb}) \\ 4735\sqrt{f_{\text{cm}28}} & (\text{SI}) \end{cases} \quad (2.23)$$

$$E_{\text{cm}607} = (1.167)^{1/2} E_{\text{cm}28} \quad (2.24)$$

$$E_{\text{cm}(t_c+T_{\text{sh}})} = \left( \frac{t_c + \tau_{\text{sh}}}{4 + 0.85(t_c + \tau_{\text{sh}})} \right)^{1/2} E_{\text{cm}28} \quad (2.25)$$

$$\tau_{\text{sh}} = \begin{cases} 190.8t_c^{-0.08}(f_{\text{cm}28})^{-0.25} \left[ 2k_s \left( \frac{V}{S} \right) \right]^2 & (\text{in.} - \text{lb}) \\ 0.085t_c^{-0.08}(f_{\text{cm}28})^{-0.25} \left[ 2k_s \left( \frac{V}{S} \right) \right]^2 & (\text{SI}) \end{cases} \quad (2.26)$$

where  $H$  is relative humidity (%).

Time function for shrinkage,  $S(t)$ , should be calculated according to the following equation:

$$S(t) = \tanh \sqrt{\frac{t - t_c}{T_{\text{sh}}}} \quad (2.27)$$

**Table 2.10** Humidity Function for Shrinkage,  $K_h$ 

Humidity	$K_h$
$H \leq 98\%$	$1 - (H/100)^3$
$H = 100\%$	-0.2
$98\% \leq H \leq 100\%$	Linear interpolation

**Table 2.11** Correction Factor  $K_s$  as Function of Cross-Sectional Shape

Cross-Sectional Shape	$K_s$
Infinite slab	1.00
Infinite cylinder	1.15
Infinite square prism	1.25
Sphere	1.30
Cube	1.55

where

- $t$  = age of concrete (days)
- $t_c$  = age of concrete drying commenced (days)
- $t - t_c$  = time from end of initial curing
- $T_{sh}$  = shrinkage half-time (days) according to Eq. 2.26
- $E_{cm28}$  = modulus of elasticity of concrete at 28 days (MPa or psi)
- $K_s$  = cross-sectional shape correction factor according to Table 2.11

If type of member is not defined,  $K_s$  can be assumed to be 1.

**Creep Calculation.** The creep function, also called creep compliance,  $J(t, t_0)$  is given by Eq. 2.28:

$$J(t, t_0) = q_1 + C_0(t, t_0) + C_d(t, t_0, t_c) \quad (2.28)$$

where

- $q_1$  = instantaneous strain, given in Eq. 2.29
- $C_0(t, t_0)$  = compliance function for basic creep composed of three terms, an aging viscoelastic term, a nonaging viscoelastic term, and an aging flow term given in Eq. 2.30
- $C_d(t, t_0, t_c)$  = compliance function for drying creep, given in Eq. 2.38

$$q_1 = \frac{0.6}{E_{cm28}} \quad (2.29)$$

The compliance function for basic creep,  $C_0(t, t_0)$ , should be calculated as follows:

$$C_0(t, t_0) = q_2 Q(t, t_0) + q_3 \ln[1 + (t - t_0)^{0.1}] + q_4 \ln \left( \frac{t}{t_0} \right) \quad (2.30)$$

where

- $q_2$  = aging viscoelastic compliance parameter
- $Q(t, t_0)$  = binomial integral
- $q_3$  = nonaging viscoelastic compliance parameter
- $q_4$  = flow compliance parameter
- $t_0$  = age of concrete at loading (days)

$$q_2 = \begin{cases} 86.8(c)^{0.5}(f_{cm_{28}})^{-0.9} \times 10^{-6} & (\text{in. - lb}) \\ 185.4(c)^{0.5}(f_{cm_{28}})^{-0.9} \times 10^{-6} & (\text{SI}) \end{cases} \quad (2.31)$$

where  $c$  is the cement content ( $\text{kg/m}^3$ ).

$$Q(t, t_0) = Q_f(t_0) \left[ 1 + \frac{Q_f(t_0)^{r(t_0)}}{Z(t, t_0)^{r(t_0)}} \right]^{-1/r(t_0)} \quad (2.32)$$

where

$$Q_f(t_0) = \frac{1}{0.086(t_0)^{2/9} + 1.21(t_0)^{4/9}} \quad (2.33)$$

$$Z(t, t_0) = \frac{\ln[1 + (t - t_0)^{0.1}]}{\sqrt{t_0}} \quad (2.34)$$

$$r(t_0) = 1.7(t_0)^{0.12} + 8 \quad (2.35)$$

$$q_3 = 0.29q_2 \left( \frac{w}{c} \right)^4 \quad (2.36)$$

$$q_4 = \begin{cases} 0.14 \left( \frac{a}{c} \right)^{-0.7} \times 10^{-6} & (\text{in. - lb}) \\ 20.3 \left( \frac{a}{c} \right)^{-0.7} \times 10^{-6} & (\text{SI}) \end{cases} \quad (2.37)$$

The compliance function for drying creep,  $C_d(t, t_0, t_c)$ , should be calculated as follows:

$$C_d(t, t_0, t_c) = q_5 \sqrt{\exp[-8H(t)] - \exp[-8H(t_0)]} \quad (2.38)$$

where  $q_5$  is a drying creep compliance parameter that can be calculated from the equation

$$q_5 = \frac{0.757 |\epsilon_{shu} \times 10^6|^{-0.6}}{f_{cm_{28}}} \quad (2.39)$$

where  $\epsilon_{shu}$  is the ultimate shrinkage strain, given by Eq. 2.21.  $H(t)$  and  $H(t_0)$  are spatial averages of pore relative humidity.

$$H(t) = 1 - \left[ \left( 1 - \frac{H}{100} \right) S(t) \right] \quad (2.40)$$

$$H(t_0) = 1 - \left[ \left( 1 - \frac{H}{100} \right) S(t_0) \right] \quad (2.41)$$

where  $S(t)$  is given by Eq. 2.27 and

$$S(t) = \tanh \sqrt{\frac{t_0 - t_c}{T_{sh}}} \quad (2.42)$$

and  $T_{sh}$  is given by Eq. 2.26.

### 2.13.3 GL 2000 Model

The GL 2000 model was developed by Gardner et al. and is described in Refs. [12] and [15].

**Shrinkage Calculation.** Parameters required for calculation of shrinkage strain using the GL 2000 model are mean 28-day concrete compressive strength,  $f_{cm_{28}}$ , relative humidity,  $H$ , age of concrete at the beginning of shrinkage,  $t_c$ , type of cement, and specimen shape.

The shrinkage strain can be calculated using the following equation:

$$\varepsilon_s(t) = \varepsilon_{shu}\beta(h)\beta(t - t_c) \quad (2.43)$$

where

$\varepsilon_{shu}$  = ultimate shrinkage strain according to Eq. 2.44

$\beta(h)$  = correction term for effect of humidity according to Eq. 2.45

$\beta(t - t_c)$  = correction term for effect of time of drying according to Eq. 2.46

Ultimate shrinkage strain should be calculated from the following equation:

$$\varepsilon_{shu} = \begin{cases} (900)K \left( \frac{4350}{f_{cm_{28}}} \right)^{1/2} \times 10^{-6} & (\text{in.} - \text{lb}) \\ (900)K \left( \frac{30}{f_{cm_{28}}} \right)^{1/2} \times 10^{-6} & (\text{SI}) \end{cases} \quad (2.44)$$

where

$K$  = shrinkage constant, which depends on cement type as shown in Table 2.12

$f_{cm_{28}}$  = mean 28-day concrete compressive strength (MPa) or psi

Shrinkage constant  $K$  can be determined from Table 2.12.

Correction term for effect of humidity,  $\beta(h)$ , should be calculated as shown:

$$\beta(h) = 1 - 1.18 \left( \frac{H}{100} \right)^4 \quad (2.45)$$

where  $H$  is the relative humidity (%).

Correction term for effect of time,  $\beta(t - t_c)$ , should be determined as follows:

$$\beta(t - t_c) = \begin{cases} \left( \frac{t - t_c}{t - t_c + 77(V/S)^2} \right)^{1/2} & (\text{in.} - \text{lb}) \\ \left( \frac{t - t_c}{t - t_c + 0.12(V/S)^2} \right)^{1/2} & (\text{SI}) \end{cases} \quad (2.46)$$

where

$t$  = age of concrete after casting (days)

$t_c$  = age of concrete at the beginning of shrinkage (days)

$V/S$  = volume-to-surface area ratio (mm or in.)

**Table 2.12** Shrinkage Constant  $K$  as Function of Cement Type

Type of Cement	$K$
I	1.00
II	0.75
III	1.15

**Creep Calculation.** The creep compliance is composed of two parts: the elastic strain and the creep strain according to the following equation:

$$J(t, t_0) = \frac{1}{E_{\text{cmt}_0}} + \frac{\phi_{28}(t, t_0)}{E_{\text{cm}_{28}}} \quad (2.47)$$

where

$$\begin{aligned} E_{\text{cmt}_0} &= \text{modulus of elasticity of concrete at loading (MPa or psi)} \\ E_{\text{cm}_{28}} &= \text{modulus of elasticity of concrete at 28 days (MPa or psi)} \\ \phi_{28}(t, t_0) &= \text{creep coefficient} \end{aligned}$$

$$E_{\text{cmt}_0} = \begin{cases} 500,000 + 52,000\sqrt{f_{\text{cmt}_0}} & (\text{in. - lb}) \\ 3500 + 4300\sqrt{f_{\text{cmt}_0}} & (\text{SI}) \end{cases} \quad (2.48)$$

where  $f_{\text{cmt}_0}$  is the concrete mean compressive strength at loading (MPa or psi), which can be determined as follows:

$$f_{\text{cmt}_0} = f_{\text{cm}_{28}} \frac{t_0^{3/4}}{a + bt_0^{3/4}} \quad (2.49)$$

Coefficients  $a$  and  $b$  are related to the cement type as shown in Table 2.13.

$$E_{\text{cm}_{28}} = 3500 + 4300\sqrt{f_{\text{cm}_{28}}} \quad (2.50)$$

Creep coefficient,  $\phi(t, t_0)$ , can be calculated as shown:

$$\phi_{28}(t, t_0) = \begin{cases} \phi(t_c) \left[ 2 \left( \frac{(t-t_0)^{0.3}}{(t-t_0)^{0.3} + 14} \right) + \left( \frac{7}{t_0} \right)^{0.5} \left( \frac{t-t_0}{t-t_0+7} \right)^{0.5} \right. \\ \quad \left. + 2.5 (1 - 1.086h^2) \left( \frac{t-t_0}{t-t_0+77(V/S)^2} \right)^{0.5} \right] & (\text{in. - lb}) \\ \phi(t_c) \left[ 2 \left( \frac{(t-t_0)^{0.3}}{(t-t_0)^{0.3} + 14} \right) + \left( \frac{7}{t_0} \right)^{0.5} \left( \frac{t-t_0}{t-t_0+7} \right)^{0.5} \right. \\ \quad \left. + 2.5 (1 - 1.086h^2) \left( \frac{t-t_0}{t-t_0+0.12(V/S)^2} \right)^{0.5} \right] & (\text{SI}) \end{cases} \quad (2.51)$$

$$\text{If } t_0 = t_c \text{ then } \phi(t_c) = 1 \quad (2.52)$$

**Table 2.13** Coefficient  $a$  and  $b$  as Function of Cement Type

Cement Type	$a$	$b$
I	2.8	0.77
II	3.4	0.72
III	1.0	0.92

$$\begin{aligned} \text{If } t_0 > t_c \quad \text{then } \phi(t_c) &= \left[ 1 - \left( \frac{t_0 - t_c}{t_0 - t_c + 77(V/S)^2} \right)^{0.5} \right]^{0.5} \quad (\text{in. - lb}) \\ \text{If } t_0 > t_c \quad \text{then } \phi(t_c) &= \left[ 1 - \left( \frac{t_0 - t_c}{t_0 - t_c + 0.12(V/S)^2} \right)^{0.5} \right]^{0.5} \quad (\text{SI}) \\ h &= \frac{H}{100} \end{aligned} \quad (2.53)$$

where  $H$  is the relative humidity (%).

#### 2.13.4 CEB 90 Model

The CEB 90 model was developed by Muller and Hillsdorf [16].

**Shrinkage Calculation.** Parameters required for calculation of shrinkage strain using the CEB 90 model are mean 28-day concrete compressive strength  $f_{cm28}$ , relative humidity  $H$ , age of concrete at the beginning of shrinkage  $t_c$ , type of cement, and specimen shape.

The strain due to shrinkage may be calculated from the following equation:

$$\varepsilon_s(t, t_c) = \varepsilon_{cs_0} \beta_s(t - t_c) \quad (2.54)$$

where

$\varepsilon_{cs_0}$  = notional shrinkage coefficient according to Eq. 2.55  
 $\beta_s(t, t_c)$  = coefficient describing development of shrinkage with time according to Eq. 2.58

Notional shrinkage coefficient is

$$\varepsilon_{cs_0} = \varepsilon_s(f_{cm28}) \beta_{RH} \quad (2.55)$$

where

$\varepsilon_s(f_{cm28})$  = concrete strength factor on shrinkage according to Eq. 2.56  
 $\beta_{RH}$  = relative humidity factor on notional shrinkage coefficient according to Table 2.14

Concrete strength factor on shrinkage,  $\varepsilon_s(f_{cm28})$ , can be calculated as

$$\varepsilon_s(f_{cm28}) = \begin{cases} \left[ 160 + 10 (\beta_{sc}) \left( 9 - \frac{f_{cm28}}{1450} \right) \right] \times 10^{-6} & (\text{in. - lb}) \\ \left[ 160 + 10 (\beta_{sc}) \left( 9 - \frac{f_{cm28}}{10} \right) \right] \times 10^{-6} & (\text{SI}) \end{cases} \quad (2.56)$$

**Table 2.14** Determination of Coefficient  $\beta_{RH}$

Humidity	$\beta_{RH}$
$40\% \leq H < 99\%$	$-1.55 \times \beta_{arh}$
$H \geq 99\%$	0.25



**Table 2.15** Coefficient  $\beta_{sc}$ 

Type of Cement	European Type	American Type	$\beta_{sc}$
Slow hardening	SL	II	4
Normal/rapid hardening	R	I	5
Rapid hardening, high strength	RS	III	8

where

$\beta_{sc}$  = coefficient that depends on type of cement according to Table 2.15.  
 $f_{cm28}$  = mean 28-day concrete compressive strength (MPa or psi)

Coefficient  $\beta_{sc}$  dependent on humidity,  $\beta_{RH}$ , should be determined according to Table 2.15, where

$$\beta_{arh} = 1 - \left( \frac{H}{100} \right)^3 \quad (2.57)$$

The development of shrinkage with time is given by

$$\beta_s(t - t_c) = \begin{cases} \sqrt{\frac{t - t_c}{350(h_e/4)^2 + (t - t_c)}} & (\text{in. - lb}) \\ \sqrt{\frac{(t - t_c)}{0.56(h_e/4)^2 + (t - t_c)}} & (\text{SI}) \end{cases} \quad (2.58)$$

where

$t$  = age of concrete (days)  
 $t_c$  = age of concrete at the beginning of shrinkage (days)  
 $h_e$  = effective thickness to account for volume/surface ratio (mm)

Effective thickness,  $h_e$ , can be determined as follows:

$$h_e = \frac{2A_c}{u} = \frac{2V}{S} \quad (2.59)$$

where

$A_c$  = cross section of the structural member (mm<sup>2</sup> or in.<sup>2</sup>)  
 $u$  = perimeter of the structural member in contact with the atmosphere (mm or in.)

**Creep Calculation.** Creep compliance represents the total stress-dependent strain per unit stress. It can be calculated as

$$J(t, t_0) = \frac{1}{E_{cmt_0}} + \frac{\phi_{28}(t, t_0)}{E_{cm28}} \quad (2.60)$$

where

$E_{cmt_0}$  = modulus of elasticity at time of loading  $t_0$  (MPa or psi)  
 $E_{cm28}$  = modulus of elasticity at 28 days (MPa or psi)  
 $\phi_{28}(t, t_0)$  = creep coefficient

$$E_{cmt_0} = E_{cm28} \exp \left[ 0.5S \left( 1 - \sqrt{\frac{28}{t_0}} \right) \right] \quad (2.61)$$

**Table 2.16** Coefficient  $S$  as Function of Cement Type

Cement Type	European Type	U.S. Type	$S$
Slow hardening	SL	II	0.38
Normal/rapid hardening	R	I	0.25
Rapid hardening high strength	RS	III	0.20

where  $S$  is the coefficient that depends on cement type and can be determined from Table 2.16.

$$E_{cm_{28}} = \begin{cases} 3,118,310 \sqrt[3]{\frac{f_{cm_{28}}}{1450}} & (\text{in. - lb}) \\ 21,500 \sqrt[3]{\frac{f_{cm_{28}}}{10}} & (\text{SI}) \end{cases} \quad (2.62)$$

Creep coefficient,  $\phi(t, t_0)$ , can be evaluated from the given equation:

$$\phi_{28}(t, t_0) = \phi_0 \beta_c(t - t_0) \quad (2.63)$$

where

$\phi_0$  = notional creep coefficient

$\beta_c(t, t_0)$  = equation describing development of creep with time after loading

$$\phi_0 = \phi_{RH} \beta(f_{cm_{28}}) \beta(t_0) \quad (2.64)$$

where  $\phi_{RH}$  is the relative humidity factor on the notional creep coefficient given by

$$\phi_{RH} = \begin{cases} 1 + \frac{1 - H/100}{0.46 \sqrt[3]{h_e/4}} & (\text{in. - lb}) \\ 1 + \frac{1 - H/100}{0.46 \sqrt[3]{h_e/100}} & (\text{SI}) \end{cases} \quad (2.65)$$

$\epsilon_{as_0}(f_{cm_{28}})$  is the concrete strength factor on the notional creep coefficient given by

$$\beta(f_{cm_{28}}) = \begin{cases} \frac{5.3}{\sqrt{f_{cm_{28}}/1450}} & (\text{in. - lb}) \\ \frac{5.3}{\sqrt{f_{cm_{28}}/10}} & (\text{SI}) \end{cases} \quad (2.66)$$

$\beta(t_0)$  is the age of concrete at loading factor on the notional creep coefficient given by

$$\beta(t_0) = \frac{1}{0.1 + t_0^{0.2}} \quad (2.67)$$

An equation describing development of creep with time after loading,  $\beta_c(t, t_0)$ , can be calculated using the following equation:

$$\beta_c(t, t_0) = \left( \frac{t - t_0}{\beta_H + t - t_0} \right)^{0.3} \quad (2.68)$$

$$\beta_H = \begin{cases} 37.5h_e [1 + (0.012H)^{18}] + 250 \leq 1500 \text{ days} & (\text{in.} - \text{lb}) \\ 1.5h_e [1 + (0.012H)^{18}] + 250 \leq 1500 \text{ days} & (\text{SI}) \end{cases} \quad (2.69)$$

### 2.13.5 CEB MC 90-99 Model

The CEB MC 90-99 is a modification of the CEB 90 and is described in Ref. 17.

**Shrinkage Calculation.** In this new model, total shrinkage contains an autogenous and drying shrinkage component. In high-performance concrete, autogenous shrinkage is significant and needs to be considered in prediction of shrinkage. This new approach was necessary so that shrinkage of normal as well as high-performance concrete can be predicted with sufficient accuracy [1].

Total shrinkage strain can be calculated using the following equation:

$$\varepsilon_s(t, t_c) = \varepsilon_{as}(t) + \varepsilon_{ds}(t, t_c) \quad (2.70)$$

where

$$\begin{aligned} \varepsilon_{as}(t) &= \text{autogenous shrinkage at time } t \\ \varepsilon_{ds}(t, t_c) &= \text{drying shrinkage at time } t \end{aligned}$$

Autogenous shrinkage,  $\varepsilon_{as}(t)$ , should be calculated as follows:

$$\varepsilon_{as}(t) = \varepsilon_{as_0}(f_{cm_{28}})\beta_{as}(t) \quad (2.71)$$

where

$$\begin{aligned} \varepsilon_{cas_0}(f_{cm_{28}}) &= \text{notional autogenous shrinkage coefficient according to Eq. 2.72} \\ \beta_{as}(t) &= \text{function to describe the time-development of autogenous shrinkage, from Eq. 2.73} \end{aligned}$$

Notional autogenous shrinkage coefficient,  $\varepsilon_{cas_0}(f_{cm})$ , can be calculated as

$$\varepsilon_{cas_0}(f_{cm_{28}}) = \begin{cases} -\alpha_{as} \left( \frac{f_{cm_{28}}/1450}{6 + f_{cm_{28}}/1450} \right)^{2.5} \times 10^{-6} & (\text{in.} - \text{lb}) \\ -\alpha_{as} \left( \frac{f_{cm_{28}}/10}{6 + f_{cm_{28}}/10} \right)^{2.5} \times 10^{-6} & (\text{SI}) \end{cases} \quad (2.72)$$

where

$$\begin{aligned} \alpha_{as} &= \text{coefficient that depends on type of cement} \\ &= 800 \text{ for slowly hardening cements (SL)} \\ &= 700 \text{ for normal or rapidly hardening cements (N or R)} \\ &= 600 \text{ for rapidly hardening high-strength cements (RS)} \\ \varepsilon_{ds_0}(f_{cm_{28}}) &= \text{mean compressive strength of concrete at an age of 28 days (MPa or psi)} \end{aligned}$$

Function  $\beta_{as}(t)$  should be calculated using the following equation:

$$\beta_{as}(t) = 1 - \exp[-0.2(t)^{0.5}] \quad (2.73)$$

where  $t$  is the age of concrete (days).

Drying shrinkage,  $\varepsilon_{ds}(t, t_c)$ , can be estimated by the equation

$$\varepsilon_{ds}(t, t_c) = \varepsilon_{ds_0}(f_{cm_{28}})\beta_{RH}(H)\beta_{ds}(t - t_c) \quad (2.74)$$

where

$\varepsilon_{ds_0}(f_{cm_{28}})$  = notional drying shrinkage coefficient according to Eq. 2.75

$\beta_{RH}(H)$  = coefficient to take into account the effect of relative humidity on drying shrinkage according to Eq. 2.76

$\beta_{ds}(t - t_c)$  = function to describe the time development of drying shrinkage according to Eq. 2.78

Notional drying shrinkage coefficient,  $\varepsilon_{ds_0}(f_{cm_{28}})$ , may be calculated from the following equation:

$$\varepsilon_{ds_0}(f_{cm_{28}}) = \begin{cases} [(220 + 110\alpha_{ds_1})\exp(-\alpha_{ds_2}f_{cm_{28}}/1450)] \times 10^{-6} & (\text{in. - lb}) \\ [(220 + 110\alpha_{ds_1})\exp(-\alpha_{ds_2}f_{cm_{28}}/10)] \times 10^{-6} & (\text{SI}) \end{cases} \quad (2.75)$$

where

$\alpha_{ds_1}$  = coefficient that depends on type of cement

= 3 for slowly hardening cements (SL)

= 4 for normal or rapidly hardening cements (N or R)

= 6 for rapidly hardening high-strength cements (RS)

$\alpha_{ds_2}$  = coefficient that depends on type of cement

= 0.13 for slowly hardening cements (SL)

= 0.12 for normal or rapidly hardening cements (N or R)

= 0.12 for rapidly hardening high-strength cements (RS)

Coefficient  $\beta_{RH}(H)$  should be calculated as follows:

$$\beta_{RH} = \begin{cases} -1.55 \left[ 1 - \left( \frac{H}{100} \right)^3 \right] & \text{for } 40\% \leq H < 99\% \times \beta_{s_1} \\ 0.25 & \text{for } H \geq 99\% \times \beta_{s_1} \end{cases} \quad (2.76)$$

where

$H$  = ambient relative humidity (%)

$\beta_{s_1}$  = coefficient to take into account the self-desiccation in high-performance concrete

It can be determined as follows:

$$\beta_{s_1} = \begin{cases} \left( \frac{3.5 \times 1450}{f_{cm_{28}}} \right)^{0.1} \leq 1.0 & (\text{in. - lb}) \\ \left( \frac{35}{f_{cm_{28}}} \right)^{0.1} \leq 1.0 & (\text{SI}) \end{cases} \quad (2.77)$$

Function  $\beta_{ds}(t - t_c)$  may be estimated as follows:

$$\beta_{ds}(t - t_c) = \begin{cases} \left( \frac{t - t_c}{350(h_e/4)^2 + (t - t_c)} \right)^{0.5} & (\text{in. - lb}) \\ \left( \frac{t - t_c}{0.56(h_e/4)^2 + (t - t_c)} \right)^{0.5} & (\text{SI}) \end{cases} \quad (2.78)$$

where

$t_c$  = concrete age at the beginning of drying (days)  
 $h_e = 2A_c/u$  = notional size of member (mm), where  $A_c$  is the cross section (mm<sup>2</sup>) and  $u$  is the perimeter of the member in contact with the atmosphere (mm)

**Creep Calculation.** Total stress-dependent strain per unit stress, also called creep compliance or creep function, can be determined as follows:

$$J(t, t_0) = \frac{1}{E_{cm_{t_0}}} + \frac{\phi_{28}(t, t_0)}{E_{cm_{28}}} \quad (2.79)$$

where

$E_{cm_{t_0}}$  = modulus of elasticity at age of loading (MPa or psi)  
 $E_{cm_{28}}$  = modulus of elasticity at day 28 (MPa or psi)  
 $\phi_{28}(t, t_0)$  = creep coefficient

$$E_{cm_{t_0}} = E_{cm_{28}} \exp \left[ 0.5S \left( 1 - \sqrt{\left( \frac{28}{t_0} \right)} \right) \right] \quad (2.80)$$

where  $S$  is the coefficient that depends on cement type and compressive strength and can be determined from Table 2.17.

$$E_{cm_{28}} = \begin{cases} 3,118,310 \sqrt[3]{\frac{f_{cm_{28}}}{1450}} & (\text{in. - lb}) \\ 21,500 \sqrt[3]{\frac{f_{cm_{28}}}{10}} & (\text{SI}) \end{cases} \quad (2.81)$$

Creep coefficient,  $\phi(t, t_0)$ , can be evaluated from the given equation:

$$\phi(t, t_0) = \phi_0 \beta_c(t, t_0) \quad (2.82)$$

where

$\phi_0$  = notional creep coefficient  
 $\beta(t, t_0)$  = equation describing development of creep with time after loading

$$\phi_0 = \phi_{RH} \beta(f_{cm_{28}}) \beta(t_0) \quad (2.83)$$

**Table 2.17** Coefficient  $S$  as Function of Cement Type and Compressive Strength

$f_{cm_{28}}$	Type of Cement	$S$
$\leq 60$ MPa (8700 psi)	Rapidly hardening high strength (RS)	0.20
$\leq 60$ MPa (8700 psi)	Normal or rapidly hardening (N or R)	0.25
$\leq 60$ MPa (8700 psi)	Slow hardening (SL)	0.38
$> 60$ MPa (8700 psi)	All types <sup>a</sup>	0.20

<sup>a</sup>Case not considered in CEB MC 90-99.

where  $\phi_{RH}$  is the relative humidity factor on the notional creep coefficient given as

$$\phi_{RH} = \begin{cases} \left[ 1 + \frac{1 - H/100}{0.46 \sqrt[3]{h_e/4}} \alpha_1 \right] \alpha_2 & (\text{in. - lb}) \\ \left[ 1 + \frac{1 - H/100}{0.46 \sqrt[3]{h_e/100}} \alpha_1 \right] \alpha_2 & (\text{SI}) \end{cases} \quad (2.84)$$

where

$$\alpha_1 = \begin{cases} \left[ \frac{3.5 \times 1450}{f_{cm_{28}}} \right]^{0.7} & (\text{in. - lb}) \\ \left[ \frac{35}{f_{cm_{28}}} \right]^{0.7} & (\text{SI}) \end{cases} \quad (2.85)$$

$$\alpha_2 = \begin{cases} \left[ \frac{3.5 \times 1450}{f_{cm_{28}}} \right]^{0.2} & (\text{in. - lb}) \\ \left[ \frac{35}{f_{cm_{28}}} \right]^{0.2} & (\text{SI}) \end{cases} \quad (2.86)$$

$\beta(f_{cm_{28}})$  is the concrete strength factor on the notional creep coefficient,

$$\beta(f_{cm_{28}}) = \begin{cases} \frac{5.3}{\sqrt{f_{cm_{28}}/1450}} & (\text{in. - lb}) \\ \frac{5.3}{\sqrt{f_{cm_{28}}/10}} & (\text{SI}) \end{cases} \quad (2.87)$$

$\beta(t_0)$  is the age of concrete at loading factor on the notional creep coefficient,

$$\beta(t_0) = \frac{1}{0.1 + t_0^{0.2}} \quad (2.88)$$

where

$$t_0 = t_{0,T} \left[ \frac{9}{2 + t_{0,T}^{1.2}} + 1 \right]^\alpha \geq 0.5 \text{ days} \quad (2.89)$$

$t_0$  = age of concrete at loading (days)

$t_{0,T}$  = age of concrete at loading adjusted according to the concrete temperature; for

$T = 20^\circ\text{C}$ ,  $t_{0,T}$  corresponds to  $t_0$

$\alpha$  = coefficient that depends on type of cement

= -1 for slowly hardening cement

= 0 for normal or rapidly hardening cement

= 1 for rapidly hardening high-strength cement

An equation describing development of creep with time after loading,  $\beta_c(t, t_0)$ , can be calculated using the following equation:

$$\beta_c(t, t_0) = \left( \frac{t - t_0}{\beta_H + t - t_0} \right)^{0.3} \quad (2.90)$$

$$\beta_H = \begin{cases} 37.5h_e [1 + (0.012H)^{18}] + 250\alpha_3 \leq 1500\alpha_3 & (\text{in. - lb}) \\ 1.5h_e [1 + (0.012H)^{18}] + 250\alpha_3 \leq 1500\alpha_3 & (\text{SI}) \end{cases} \quad (2.91)$$

$$\alpha_3 = \begin{cases} \left[ \frac{3.5 \times 1450}{f_{\text{cm}_{28}}} \right]^{0.5} & (\text{in. - lb}) \\ \left[ \frac{35}{f_{\text{cm}_{28}}} \right]^{0.5} & (\text{SI}) \end{cases} \quad (2.92)$$

### 2.13.6 fib MC 2010 Model

The fib MC 2010 model is a modification of the CEB MC 90-99 model and is described in Ref. 18.

**Shrinkage Calculation.** The equations utilized by the fib MC 2010 shrinkage prediction model are similar to those of the CEB MC 90-99 model. Shrinkage predictions according to the fib MC 2010 model can be calculated as described in the **Shrinkage Calculation** area of Section 2.13.5.

**Creep Calculation.** The creep compliance, or the total stress-dependent strain per unit stress is calculated by the following equation:

$$J(t, t_0) = \frac{1}{E_{\text{ci}}(t_0)} + \frac{\phi(t, t_0)}{E_{\text{ci}}} \quad (2.93)$$

where

- $E_{\text{ci}}$  = elastic modulus at 28 days according to Equation 2.94
- $E_{\text{ci}}(t_0)$  = elastic modulus at age of loading according to Equation 2.95
- $\phi(t, t_0)$  = creep coefficient found by Equation 2.96
- $t_0$  = age of concrete at time of loading (days)
- $t$  = age of concrete (days)

The elastic modulus of concrete at 28 days can be found by the expression:

$$E_{\text{ci}} = \begin{cases} 3,118,310 \sqrt[3]{\frac{f_{\text{cm}}}{1450}} & (\text{in. - lb}) \\ 21,500 \sqrt[3]{\frac{f_{\text{cm}}}{10}} & (\text{SI}) \end{cases} \quad (2.94)$$

where

- $f_{\text{cm}}$  = mean compressive strength of concrete at 28 days of age (MPa or psi)

The elastic modulus at the age of loading can be predicted from the following expression:

$$E_{\text{ci}}(t_0) = E_{\text{ci}} \exp \left[ 0.5S \left( 1 - \sqrt{\left( \frac{28}{t_0} \right)} \right) \right] \quad (2.95)$$

where

- S = coefficient that depends on type of cement and compressive strength  
 = 0.20 for  $f_{cm} \leq 60$  MPa (8700 psi) and rapidly hardening high-strength cement (Type III)  
 = 0.25 for  $f_{cm} \leq 60$  MPa (8700 psi) and normal and rapidly hardening cement (Type I)  
 = 0.38 for  $f_{cm} \leq 60$  MPa (8700 psi) and slow-hardening cement (Type II)  
 = 0.20 for  $f_{cm} > 60$  MPa (8700 psi) and all types of cement

The creep coefficient,  $\phi(t, t_0)$ , may be found using the following expression:

$$\phi(t, t_0) = \phi_{bc}(t, t_0) + \phi_{dc}(t, t_0) \quad (2.96)$$

where

- $\phi_{bc}(t, t_0)$  = basic creep coefficient found from Equation 2.97  
 $\phi_{dc}(t, t_0)$  = drying creep coefficient found from Equation 2.101

The basic creep coefficient,  $\phi_{bc}(t, t_0)$ , can be found from the following expression:

$$\phi_{bc}(t, t_0) = \beta_{bc}(f_{cm})\beta_{bc}(t, t_0) \quad (2.97)$$

with

$$\beta_{bc}(f_{cm}) = \begin{cases} \frac{58.6}{(f_{cm})^{0.7}} & (\text{in.-lb}) \\ \frac{1.8}{(f_{cm})^{0.7}} & (\text{SI}) \end{cases} \quad (2.98)$$

$$\beta_{bc}(t, t_0) = \ln \left[ \left( \frac{30}{t_{0,\text{adj}}} + 0.035 \right)^2 (t - t_0) + 1 \right] \quad (2.99)$$

where

- $t_{0,\text{adj}}$  = modified age of loading accounting for the effect of creep due to the type of cement according to Equation 2.100.

$$t_{0,\text{adj}} = t_{0,T} \left[ \frac{9}{2 + t_{0,T}^{1.2}} + 1 \right]^\alpha \geq 0.5 \text{ days} \quad (2.100)$$

where

- $t_{0,T}$  = age of concrete at loading adjusted according to the concrete temperature;  
 for  $T = 20^\circ\text{C}$ ,  $t_{0,T}$  corresponds to  $t_0$   
 $\alpha$  = coefficient, which depends on the type of cement  
 = -1 for slowly hardening or Type II cement  
 = 0 for normal or rapidly hardening or Type I cement  
 = 1 for rapidly hardening high-strength or Type III cement

The drying creep coefficient,  $\phi_{dc}(t, t_0)$ , may be calculated using the expression:

$$\phi_{dc}(t, t_0) = \beta_{dc}(f_{cm}) \cdot \beta(RH) \cdot \beta_{dc}(t_0) \cdot \beta_{dc}(t, t_0) \quad (2.101)$$



with

$$\beta_{dc}(f_{cm}) = \begin{cases} \frac{437,333}{(f_{cm})^{1.4}} & \text{(in.-lb)} \\ \frac{412}{(f_{cm})^{1.4}} & \text{(SI)} \end{cases} \quad (2.102)$$

$$\beta(RH) = \begin{cases} \frac{\left(1 - \frac{RH}{100}\right)}{\sqrt[3]{0.1 \left(\frac{h}{4}\right)}} & \text{(in.-lb)} \\ \frac{\left(1 - \frac{RH}{100}\right)}{\sqrt[3]{0.1 \left(\frac{h}{100}\right)}} & \text{(SI)} \end{cases} \quad (2.103)$$

$$\beta_{dc}(t_0) = \frac{1}{0.1 + t_{0,adj}^{0.2}} \quad (2.104)$$

$\beta_{dc}(t, t_0)$  = drying creep development with time calculated by Equation 2.105:

$$\beta_{dc}(t, t_0) = \left[ \frac{(t - t_0)}{\beta_h + (t - t_0)} \right]^{\gamma(t_0)} \quad (2.105)$$

where

$$\gamma(t_0) = \frac{1}{2.3 + \frac{3.5}{\sqrt{t_{0,adj}}}} \quad (2.106)$$

$$\beta_h = \begin{cases} 38.1h + 250\alpha_{fcm} \leq 1500\alpha_{fcm} & \text{(in.-lb)} \\ 1.5 \cdot h + 250\alpha_{fcm} \leq 1500\alpha_{fcm} & \text{(SI)} \end{cases} \quad (2.107)$$

where

$$\alpha_{fcm} = \begin{cases} \left(\frac{5075}{f_{cm}}\right)^{0.5} & \text{(in.-lb)} \\ \left(\frac{35}{f_{cm}}\right)^{0.5} & \text{(SI)} \end{cases} \quad (2.108)$$

where

$f_{cm}$  = mean compressive strength of concrete at 28 days of age (MPa or psi)

$RH$  = relative humidity of the ambient environment (%)

$h = 2A_c/u$  is the notional size of member (mm or in.), where  $A_c$  is the area of the cross section (mm<sup>2</sup> or in.<sup>2</sup>) and  $u$  is the perimeter of the member in contact with the atmosphere (mm or in.)

### 2.13.7 The AASHTO Model

The model is described by AASHTO LRFD (Section 5.4.2.3.3) bridge design specifications in Ref. 19.

**Shrinkage Calculation.** Parameters required for calculation of shrinkage strain using the AASHTO model are: curing method (moist-cured or steam-cured concrete), 28-day concrete compressive strength,  $f_{cm_{28}}$ , relative humidity,  $H$ , drying time of concrete,  $t$ , type of cement, and specimen shape.

The strain due to shrinkage may be calculated from the following equation:

$$\varepsilon_{sh} = k_s k_{hs} k_f k_{td} (0.48 \times 10^{-3}) \quad (2.109)$$

where

- $t$  = drying time (day)
- $k_s$  = size factor for shrinkage specified in Eq. 2.111
- $k_h$  = humidity factor for shrinkage specified in Eq. 2.112
- $k_f$  = factor for the effect of concrete strength specified in Eq. 2.113
- $k_{td}$  = time development factor

Time development factor for shrinkage should be calculated as follows:

$$k_{td} = \begin{cases} \left( \frac{t}{61 - (4/1000)f'_c + t} \right) & (f'_c \text{ in psi (in.-lb)}) \\ \left( \frac{t}{61 - 0.58f'_c + t} \right) & (f'_c \text{ in MPa (SI)}) \end{cases} \quad (2.110)$$

Size factor for shrinkage should be calculated as follows:

$$k_s = \begin{cases} \left[ \frac{t / (26e^{0.36(V/S)} + t)}{t / (45 + t)} \right] \left[ \frac{1064 - 94(V/S)}{923} \right] & (\text{in. - lb}) \\ \left[ \frac{t / (26e^{0.0142(V/S)} + t)}{t / (45 + t)} \right] \left[ \frac{1064 - 3.70(V/S)}{923} \right] & (\text{SI}) \end{cases} \quad (2.111)$$

where

- $V$  = volume of the specimen (in.<sup>3</sup>)
- $S$  = surface of the specimen (in.<sup>2</sup>)
- $f'_{ci}$  = specified compressive strength of concrete at time of prestressing for pretension members and at time of initial loading for non-prestressed member. If concrete age at time of initial loading is unknown at design time,  $f'_c$  shall be taken as  $0.80f'_c$  (ksi or MPa)

Humidity factor for shrinkage is

$$k_{hs} = [2.0 - 0.014H] \quad (2.112)$$

where  $H$  is the relative humidity (%).

$$k_f = \begin{cases} \frac{5}{1 + f'_{ci}} & (\text{in. - lb}) \\ \frac{35}{7 + f'_{ci}} & (\text{SI}) \end{cases} \quad (2.113)$$

**Creep Calculation.** The creep compliance represents the total stress-dependent strain per unit stress. It can be calculated as

$$J(t, t_0) = \frac{1}{E_c} + \frac{\psi(t, t_0)}{E_c} \quad (2.114)$$

where

$\psi(t, t_0)$  = creep coefficient as given in Eq. 2.115

$E_c$  = modulus of elasticity at 28 days (ksi) as given in Eq. 2.120

The creep coefficient may be calculated from the following equation:

$$\psi(t, t_0) = 1.9k_s k_{hc} k_f k_{td} t_0^{-0.118} \quad (2.115)$$

where

$t$  = maturity of concrete (day)

$t_0$  = age of concrete when load is initially applied (day)

$k_f$  = factor for the effect of concrete strength as given in Eq. 2.116

$k_s$  = factor for the effect of the volume-to-surface ratio of the component as given in Eq. 2.117

$k_{hc}$  = humidity factor for creep

$k_{td}$  = time development factor

The factor for the effect of concrete strength should be calculated as follows:

$$k_f = \begin{cases} \frac{5}{1 + f'_{ci}} & (\text{in. - lb}) \\ \frac{35}{7 + f'_{ci}} & (\text{SI}) \end{cases} \quad (2.116)$$

where  $f'_{ci}$  is the specified concrete compressive strength at time of initial loading.

The factor for the effect of the volume-to-surface ratio of the component should be calculated as follows:

$$k_s = \begin{cases} 1.45 - 0.13(V/S) \geq 1.0 & (\text{in. - lb}) \\ 1.45 - 0.0051(V/S) \geq 1.0 & (\text{SI}) \end{cases} \quad (2.117)$$

where

$V$  = volume of the specimen (in.<sup>3</sup>)

$S$  = surface of the specimen (in.<sup>2</sup>)

Humidity factor is given by following equations:

$$k_{hc} = 1.56 - 0.008H \quad (2.118)$$

Time development factor:

$$k_{td} = \begin{cases} \left( \frac{t}{61 - 4f'_{ci} + t} \right) & (\text{in. - lb}) \\ \left( \frac{t}{61 - 0.58f'_{ci} + t} \right) & (\text{SI}) \end{cases} \quad (2.119)$$

The modulus of elasticity at 28 days should be calculated as follows:

$$E_c = \begin{cases} 33000\omega_c^{1.5}\sqrt{f'_c} & (\text{in.} - \text{lb}) \\ 0.043\omega_c^{1.5}\sqrt{f'_c} & (\text{SI}) \end{cases} \quad (2.120)$$

where

$\omega_c$  = concrete unit weight (kip/ft<sup>3</sup>) or kg/m<sup>3</sup>

$f'_c$  = specified concrete compressive strength at 28 days (ksi or MPa)

### Example 2.1 (in.-lb Units)

Calculate the shrinkage strain and creep compliance and coefficient for the concrete specimen given below. Use the ACI 209R-92 model.

Given factors:

Humidity = 75%

$h_c = 2V/S = 2A_c/u = 3$  in.

$f_{cm_{28}} = 6556$  psi

$w = 345$  lb/yd<sup>3</sup>

$w/c = 0.46$

$a/c = 3.73$

$t = 35$  days

$t_0 = 28$  days

$t_c = 8$  days

$\gamma = 146$  lb/ft<sup>3</sup>

Cement type III

Moist-cured concrete

### Solution

*Shrinkage Calculation*

$$\epsilon_{sh}(t, t_c) = \frac{t - t_c}{f + (t - t_c)} K_{ss} K_{sh} \epsilon_{shu}$$

$$\epsilon_{shu} = 780 \times 10^{-6} \text{ in./in.}$$

According to Table 2.4,  $f = 35$

$$\frac{V}{S} = 1.5 \text{ in.}$$

$$K_{ss} = 1.23 - 0.152 \left( \frac{V}{S} \right) = 1.23 - 0.152(1.5) = 1.002$$

For  $H = 75\%$ ,

$$K_{sh} = 1.40 - 0.01H = 1.40 - 0.01(75) = 0.65$$

$$\epsilon_{sh}(t, t_c) = \frac{t - t_c}{f + (t - t_c)} K_{ss} K_{sh} \epsilon_{shu}$$

$$= \frac{35 - 8}{35 + (35 - 8)} (1.002)(0.65)(780 \times 10^{-6}) = 222.3 \times 10^{-6} \text{ in./in.}$$

*Creep Calculation*

$$J(t, t_0) = \frac{1 + C_c(t)}{E_{cm_{t_0}}}$$

Determination of  $E_{cm_{t_0}}$ :

$$a = 2.30 \quad b = 0.92 \text{ (Table 2.5)}$$

$$f'_c(t_0) = f_{cm_{28}} \frac{t_0}{a + bt_0} = 6556 \frac{28}{2.3 + 0.92 \times 28} = 6542 \text{ psi}$$

$$E_{cm_{t_0}} = 33(\gamma)^{3/2} \sqrt{f'_c(t_0)} = 33(146)^{3/2} \sqrt{6542} = 4,708,673 \text{ psi}$$

Determination of  $C_c(t)$ :

$$C_{cu} = 2.35$$

$$K_{ch} = 1.27 - 0.0067(H) = 1.27 - 0.0067(75) = 0.768$$

$$K_{ca} = 1.25(t_0)^{-0.118} = 1.25(28)^{-0.118} = 0.844$$

$$K_{cs} = 1.14 - 0.092 \left( \frac{V}{S} \right) = 1.14 - 0.138 = 1.002$$

$$C_c(t) = \frac{(t - t_0)^{0.60}}{10 + (t - t_0)^{0.60}} C_{cu} K_{ch} K_{ca} K_{cs} = \frac{(35 - 28)^{0.60}}{10 + (35 - 28)^{0.60}} 2.35 \times 0.768 \times 0.844 \times 1.002 = 0.37$$

$$J(t, t_0) = \frac{1 + C_c(t)}{E_{cm_{t_0}}} = \frac{1 + 0.37}{4,708,673} = 0.29 \times 10^{-6} \text{ psi}^{-1}$$

**Example 2.2 (in.-lb Units)**

Using the B3 model, calculate the shrinkage strain and creep function for the specimen given in Example 2.1.

**Solution***Shrinkage Calculation*

$$\epsilon_s(t) = (\epsilon_{shu})(K_h)S(t)$$

Determination of  $\epsilon_{shu}$ :

$$\alpha_1 = 1.10 \text{ (Table 2.8)}$$

$$\alpha_2 = 1.0 \text{ (Table 2.9)}$$

$$\epsilon_{shu} = -\epsilon_{su} \frac{E_{cm607}}{E_{cm(t_c + \tau_{sh})}}$$

$$\begin{aligned} \epsilon_{su} &= -\alpha_1 \alpha_2 [0.025(w)^{2.1} (f_{cm_{28}})^{-0.28} + 270] \times 10^{-6} \\ &= -(1.10)(1.0)[0.025(345)^{2.1} (6556)^{-0.28} + 270] \times 10^{-6} = -798 \times 10^{-6} \text{ in./in.} \end{aligned}$$

$$E_{cm_{28}} = 57000 \sqrt{f_{cm_{28}}} = 57,000 \sqrt{6556} = 4,615,240 \text{ psi}$$

$$k_s = 1.0$$

(Since the type of member is not defined)

$$\begin{aligned}\tau_{sh} &= 190.8(t_c)^{-0.08}(f_{cm28})^{-0.25} \left[ 2k_s \left( \frac{V}{S} \right) \right]^2 \\ &= 190.8(8)^{-0.08}(6556)^{-0.25} [2(1)(1.5)]^2 \\ &= 161.58 \text{ days}\end{aligned}$$

$$\begin{aligned}E_{cm607} &= (1.167)^{1/2} E_{cm28} \\ &= (1.167)^{1/2} (4,615,240) = 4,985,741 \text{ psi}\end{aligned}$$

$$\begin{aligned}E_{cm(t_c + \tau_{sh})} &= \left( \frac{t_c + \tau_{sh}}{4 + 0.85(t_c + \tau_{sh})} \right)^{1/2} E_{cm28} = \left( \frac{8 + 161.58}{4 + 0.85(8 + 161.58)} \right)^{1/2} (4,615,240) \\ &= 4,937,886 \text{ psi}\end{aligned}$$

$$\epsilon_{shu} = -\epsilon_{su} \frac{E_{cm607}}{E_{cm(t_c + \tau_{sh})}} = -(-798 \times 10^{-6}) \frac{4,985,741}{4,937,886} = 806 \times 10^{-6} \text{ in./in.}$$

Determination of  $K_h$ :

According to the Table 2.10, for  $H = 75\%$

$$K_h = 1 - \left( \frac{H}{100} \right)^3 = 1 - \left( \frac{75}{100} \right)^3 = 0.578$$

Determination of  $S(t)$ :

$$S(t) = \tanh \sqrt{\frac{t - t_c}{T_{sh}}} = \tanh \sqrt{\frac{35 - 8}{161.58}} = 0.387$$

$$\epsilon_s(t) = (\epsilon_{shu})(K_h)S(t) = (806 \times 10^{-6})(0.578)(0.387) = 180 \times 10^{-6} \text{ in./in.}$$

*Creep Calculation*

$$J(t, t_0) = q_1 + C_0(t, t_0) + C_d(t, t_0, t_c)$$

Determination of  $q_1$ :

$$q_1 = \frac{0.6}{E_{cm28}} = \frac{0.6}{4,615,240} = 1.3 \times 10^{-7} \text{ psi}^{-1}$$

Calculation of  $C_0(t, t_0)$ :

$$c = \frac{w}{w/c} = \frac{345}{0.46} = 750 \text{ lb/yd}^3$$

$$\begin{aligned}q_2 &= 86.8(c)^{0.5}(f_{cm28})^{-0.9} \times 10^{-6} = 86.8(750)^{0.5}(6556)^{-0.9} \times 10^{-6} \\ &= 0.873 \times 10^{-6}\end{aligned}$$

$$Q_f(t_0) = \frac{1}{0.086(t_0)^{2/9} + 1.21(t_0)^{4/9}} = \frac{1}{0.086(28)^{2/9} + 1.21(28)^{4/9}} = 0.182$$

$$Z(t, t_0) = \frac{\ln[1 + (t - t_0)^{0.1}]}{\sqrt{t_0}} = \frac{\ln[1 + (35 - 28)^{0.1}]}{\sqrt{28}} = 0.150$$

$$r(t_0) = 1.7(t_0)^{0.12} + 8 = 1.7(28)^{0.12} + 8 = 10.54$$

$$Q(t, t_0) = Q_f(t_0) \left[ 1 + \frac{Q_f(t_0)^{r(t_0)}}{Z(t, t_0)^{r(t_0)}} \right]^{-1/r(t_0)} = 0.182 \left[ 1 + \frac{0.182^{10.54}}{0.150^{10.54}} \right]^{-1/10.54} = 0.148$$

$$q_3 = 0.29q_2 \left( \frac{w}{c} \right)^4 = 0.29(0.873 \times 10^{-6})(0.46)^4 = 0.011 \times 10^{-6}$$

$$q_4 = 0.14 \left( \frac{a}{c} \right)^{-0.7} \times 10^{-6} = 0.14(3.73)^{-0.7} \times 10^{-6} = 5.57 \times 10^{-8}$$

$$\begin{aligned} C_0(t, t_0) &= q_2 Q(t, t_0) + q_3 \ln[1 + (t - t_0)^{0.1}] + q_4 \ln \left( \frac{t}{t_0} \right) \\ &= (0.873 \times 10^{-6})(0.148) + (0.011 \times 10^{-6}) \ln[1 + (35 - 28)^{0.1}] + (5.57 \times 10^{-8}) \ln \left( \frac{35}{28} \right) \\ &= 0.15 \times 10^{-6} \text{ psi}^{-1} \end{aligned}$$

Calculation of  $C_d(t, t_0, t_c)$ :

$$q_5 = \frac{0.757 |\epsilon_{shu} \times 10^6|^{-0.6}}{f_{cm28}} = \frac{0.757 |806 \times 10^{-6} \times 10^6|^{-0.6}}{6556} = 2.08 \times 10^{-6}$$

$$S(t) = 0.387$$

$$S(t_0) = \tanh \sqrt{\frac{t_0 - t_c}{T_{sh}}} = \tanh \sqrt{\frac{28 - 8}{161.58}} = 0.338$$

$$H(t) = 1 - \left[ \left( 1 - \frac{H}{100} \right) S(t) \right] = 1 - \left[ \left( 1 - \frac{75}{100} \right) 0.387 \right] = 0.903$$

$$H(t_0) = 1 - \left[ \left( 1 - \frac{H}{100} \right) S(t_0) \right] = 1 - \left[ \left( 1 - \frac{75}{100} \right) 0.338 \right] = 0.916$$

$$\begin{aligned} C_d(t, t_0, t_c) &= q_5 \sqrt{\exp[-8H(t)] - \exp[-8H(t_0)]} \\ &= (2.08 \times 10^{-6}) \sqrt{\exp[-8 \times 0.903] - \exp[-8 \times 0.916]} = 0.0176 \times 10^{-6} \text{ psi}^{-1} \end{aligned}$$

$$\begin{aligned} J(t, t_0) &= q_1 + C_0(t, t_0) + C_d(t, t_0, t_c) \\ &= (1.3 \times 10^{-7}) + (0.15 \times 10^{-6}) + (0.0176 \times 10^{-6}) = 0.298 \times 10^{-6} \text{ psi}^{-1} \end{aligned}$$

Creep coefficient

$$c_c(t, t_0) = J(t, t_0) E_{cm28} - 1 = (0.298 \times 10^{-6})(4615240) - 1 = 0.375$$

### Example 2.3 (in.-lb Units)

Using the GL 2000 model, calculate the shrinkage strain and creep compliance and coefficient for the specimen given in Example 2.1.

#### Solution

*Shrinkage Calculation*

$$\epsilon_s(t) = \epsilon_{shu} \beta(h) \beta(t - t_c)$$

Calculation of  $\epsilon_{shu}$ :

$$K = 1.15 \quad (\text{Table 2.12})$$

$$\epsilon_{shu} = (900)K \left( \frac{4350}{f_{cm28}} \right)^{1/2} \times 10^{-6} = (900)(1.15) \left( \frac{4350}{6556} \right)^{1/2} \times 10^{-6} = 843 \times 10^{-6} \text{ in./in.}$$

Calculation of  $\beta(h)$ :

$$\beta(h) = 1 - 1.18 \left( \frac{H}{100} \right)^4 = 1 - 1.18 \left( \frac{75}{100} \right)^4 = 0.627$$

Calculation of  $\beta(t - t_c)$ :

$$\beta(t - t_c) = \left( \frac{t - t_c}{t - t_c + 77(V/S)^2} \right)^{1/2} = \left( \frac{35 - 8}{35 - 8 + 77(1.5)^2} \right)^{1/2} = 0.367$$

$$\epsilon_s(t) = \epsilon_{shu} \beta(h) \beta(t - t_c) = (843 \times 10^{-6})(0.627)(0.367) = 194 \times 10^{-6} \text{ in./in.}$$

*Creep Calculation*

$$J(t, t_0) = \frac{1}{E_{cm t_0}} + \frac{\phi_{28}(t, t_0)}{E_{cm 28}}$$

Calculation of  $E_{cm t_0}$  and  $E_{cm 28}$ :

$$t_0 = 28 \text{ days} \Rightarrow E_{cm t_0} = E_{cm 28}$$

$$E_{cm 28} = 500,000 + 52,000 \sqrt{f_{cm 28}} = 500,000 + 52000 \sqrt{6556} = 4,710,395 \text{ psi}$$

Calculation of  $\phi(t, t_0)$ :

$$t_0 = 28 > t_c = 8 \text{ days}$$

$$\phi(t_c) = \left[ 1 - \left( \frac{t_0 - t_c}{t_0 - t_c + 77(V/S)^2} \right)^{0.5} \right]^{0.5} = \left[ 1 - \left( \frac{28 - 8}{28 - 8 + 77(1.5)^2} \right)^{0.5} \right]^{0.5} = 0.824$$

$$h = \frac{H}{100} = \frac{75}{100} = 0.75$$

$$\begin{aligned} \phi_{28}(t, t_0) &= \phi(t_c) \left[ 2 \left( \frac{(t - t_0)^{0.3}}{(t - t_0)^{0.3} + 14} \right) + \left( \frac{7}{t_0} \right)^{0.5} \left( \frac{t - t_0}{t - t_0 + 7} \right)^{0.5} \right. \\ &\quad \left. + 2.5(1 - 1.086h^2) \left( \frac{t - t_0}{t - t_0 + 77(V/S)^2} \right)^{0.5} \right] \\ &= 0.824 \left[ 2 \left( \frac{(35 - 28)^{0.3}}{(35 - 28)^{0.3} + 14} \right) + \left( \frac{7}{28} \right)^{0.5} \left( \frac{35 - 28}{35 - 28 + 7} \right)^{0.5} \right. \\ &\quad \left. + 2.5(1 - 1.086(0.75)^2) \left( \frac{35 - 28}{35 - 28 + 77(1.5)^2} \right)^{0.5} \right] = 0.636 \end{aligned}$$

$$J(t, t_0) = \frac{1}{E_{cm t_0}} + \frac{\phi_{28}(t, t_0)}{E_{cm 28}} = \frac{1}{4,710,394} + \frac{0.636}{4,710,395} = 0.347 \times 10^{-6} \text{ psi}^{-1}$$



**Example 2.4 (in.-lb Units)**

Using the CEB 90 model, calculate the shrinkage strain and creep compliance and coefficient for the specimen given in Example.2.1

**Solution***Shrinkage Calculation*

$$\varepsilon_s(t, t_c) = (\varepsilon_{cs_0})\beta_s(t - t_c)$$

Calculation of  $\varepsilon_{cs_0}$ :

$$\varepsilon_{cs_0} = \varepsilon_s(f_{cm28})\beta_{RH}$$

$$\beta_{sc} = 8$$

$$\begin{aligned}\varepsilon_s(f_{cm28}) &= \left[ 160 + 10 (\beta_{sc}) \left( 9 - \frac{f_{cm28}}{1450} \right) \right] \times 10^{-6} \\ &= \left[ 160 + 10 (8) \left( 9 - \frac{6556}{1450} \right) \right] \times 10^{-6} = 518.3 \times 10^{-6} \text{ in./in.}\end{aligned}$$

For  $H = 75\%$ ,

$$\beta_{RH} = -1.55\beta_{arh}$$

$$\beta_{arh} = 1 - \left( \frac{H}{100} \right)^3 = 1 - \left( \frac{75}{100} \right)^3 = 0.578$$

$$\beta_{RH} = -1.55\beta_{arh} = -1.55 \times 0.578 = -0.896$$

$$\varepsilon_{cs_0} = \varepsilon_s(f_{cm28})(\beta_{RH}) = (518.3 \times 10^{-6})(-0.896) = -464.4 \times 10^{-6} \text{ in./in.}$$

Calculation of  $\beta_s(t - t_c)$ :

$$h_e = \frac{2A_c}{u} = 2 \times 1.5 = 3.0 \text{ in.}$$

$$\beta_s(t - t_c) = \sqrt{\frac{t - t_c}{350(h_e/4)^2 + (t - t_c)}} = \sqrt{\frac{35 - 8}{350\left(\frac{3}{4}\right)^2 + (35 - 8)}} = 0.347$$

$$\varepsilon_s(t, t_c) = (\varepsilon_{cs_0})\beta_s(t - t_c) = (-464.2 \times 10^{-6})(0.347) = -161 \times 10^{-6} \text{ in./in.}$$

*Creep Calculation*

$$J(t, t_0) = \frac{1}{E_{cmt_0}} + \frac{\phi_{28}(t, t_0)}{E_{cm28}}$$

Calculation of  $E_{cmt_0}$  and  $E_{cm28}$ :

$$t_0 = 28 \text{ days} \Rightarrow E_{cmt_0} = E_{cm28}$$

$$E_{cm28} = 3,118,310 \sqrt[3]{\frac{f_{cm28}}{1450}} = 3,118,310 \sqrt[3]{\frac{6556}{1450}} = 5,156,356 \text{ psi}$$

Calculation of  $\phi(t, t_0)$ :

$$\phi_{RH} = 1 + \frac{1 - H/100}{0.46\sqrt[3]{h_e/4}} = 1 + \frac{1 - 75/100}{0.46\sqrt[3]{3/4}} = 1.598$$

$$\beta(f_{cm_{28}}) = \frac{5.3}{\sqrt{f_{cm_{28}}/1450}} = \frac{5.3}{\sqrt{6556/1450}} = 2.49$$

$$\beta(t_0) = \frac{1}{0.1 + t_0^{0.2}} = \frac{1}{0.1 + 28^{0.2}} = 0.488$$

$$\phi_0 = \phi_{RH}\beta(f_{cm_{28}})\beta(t_0) = (1.598)(2.49)(0.488) = 1.94$$

$$\begin{aligned}\beta_H &= 37.5h_e[1 + (0.012H)^{18}] + 250 = 37.5(3)[1 + (0.012 \times 75)^{18}] + 250 \\ &= 379.4 \leq 1500 \text{ days}\end{aligned}$$

$$\beta_c(t, t_0) = \left(\frac{t - t_0}{\beta_H + t - t_0}\right)^{0.3} = \left(\frac{35 - 28}{379.4 + 35 - 28}\right)^{0.3} = 0.3$$

$$\phi_{28}(t, t_0) = \phi_0\beta_c(t, t_0) = 1.94 \times 0.3 = 0.582$$

$$J(t, t_0) = \frac{1}{E_{cm_{t_0}}} + \frac{\phi(t, t_0)}{E_{cm_{28}}} = \frac{1}{5,156,356} + \frac{0.582}{5,156,356} = 0.307 \times 10^{-6} \text{ psi}^{-1}$$

### Example 2.5 (in.-lb Units)

Use the CEB MC 90-99 model to calculate the shrinkage strain and creep compliance and coefficient for the specimen given in Example 2.1.

#### Solution

*Shrinkage Calculation*

$$\varepsilon_s(t, t_c) = \varepsilon_{as}(t) + \varepsilon_{ds}(t, t_c)$$

Calculation of  $\varepsilon_{as}(t)$ :

$$\alpha_{as} = 600 \text{ for rapidly hardening high - strength cements}$$

$$\begin{aligned}\varepsilon_{as_0}(f_{cm_{28}}) &= -\alpha_{as} \left(\frac{f_{cm_{28}}/1450}{6 + f_{cm_{28}}/1450}\right)^{2.5} \times 10^{-6} \\ &= -600 \left(\frac{6556/1450}{6 + 6556/1450}\right)^{2.5} \times 10^{-6} = -72.64 \times 10^{-6} \text{ in./in.}\end{aligned}$$

$$\beta_{as}(t) = 1 - \exp(-0.2(t)^{0.5}) = 1 - \exp(-0.2(35)^{0.5}) = 0.694$$

$$\varepsilon_{as}(t) = \varepsilon_{as_0}(f_{cm_{28}})\beta_{as}(t) = (-72.64 \times 10^{-6})(0.694) = -50.41 \times 10^{-6} \text{ in./in.}$$

Calculation of  $\varepsilon_{ds}(t, t_c)$ :

$$\alpha_{ds_1} = 6 \text{ for rapidly hardening high - strength cements}$$

$$\alpha_{ds_2} = 0.12 \text{ for rapidly hardening high - strength cements}$$

$$\begin{aligned}\varepsilon_{ds_0}(f_{cm_{28}}) &= [(220 + 110\alpha_{ds_1}) \exp(-\alpha_{ds_2}f_{cm_{28}}/1450)] \times 10^{-6} \\ &= [(220 + 110 \times 6) \exp(-0.12 \times 6556/1450)] \times 10^{-6} = 511.5 \times 10^{-6} \text{ in./in.}\end{aligned}$$

$$\beta_{s1} = \left( \frac{35 \times 1450}{f_{cm_{28}}} \right)^{0.1} = \left( \frac{35 \times 1450}{6556} \right)^{0.1} = 1.23 \geq 1.0$$

$$\beta_{s1} = 1.0$$

$$\beta_{RH} = -1.55 \left[ 1 - \left( \frac{H}{100} \right)^3 \right] = -1.55 \left[ 1 - \left( \frac{75}{100} \right)^3 \right] = -0.896$$

$$\begin{aligned} \beta_{ds}(t - t_c) &= \left( \frac{t - t_c}{350(h_e/4)^2 + (t - t_c)} \right)^{0.5} \\ &= \left( \frac{35 - 8}{350\left(\frac{3}{4}\right)^2 + (35 - 8)} \right)^{0.5} = 0.347 \end{aligned}$$

$$\begin{aligned} \varepsilon_{ds}(t, t_c) &= \varepsilon_{ds_0}(f_{cm_{28}})\beta_{RH}(H)\beta_{ds}(t - t_c) \\ &= (511.5 \times 10^{-6})(-0.896)(0.347) = -159 \times 10^{-6} \text{ in./in.} \end{aligned}$$

$$\varepsilon_s(t, t_c) = \varepsilon_{as}(t) + \varepsilon_{ds}(t, t_c) = (-50.41 \times 10^{-6}) + (-159 \times 10^{-6}) = -209 \times 10^{-6} \text{ in./in.}$$

### Creep Calculation

$$J(t, t_0) = \frac{1}{E_{cmt_0}} + \frac{\phi_{28}(t, t_0)}{E_{cm_{28}}}$$

Calculation of  $E_{cmt_0}$  and  $E_{cm_{28}}$ :

$$t_0 = 28 \text{ days} \Rightarrow E_{cmt_0} = E_{cm_{28}}$$

$$E_{cm_{28}} = 3,118,310 \sqrt[3]{\frac{f_{cm_{28}}}{1450}} = 3,118,310 \sqrt[3]{\frac{6556}{1450}} = 5,156,356 \text{ psi}$$

Calculation of  $\phi(t, t_0)$ :

$$\alpha_1 = \left[ \frac{3.5 \times 1450}{f_{cm_{28}}} \right]^{0.7} = \left[ \frac{3.5 \times 1450}{6556} \right]^{0.7} = 0.84$$

$$\alpha_2 = \left[ \frac{3.5 \times 1450}{f_{cm_{28}}} \right]^{0.2} = \left[ \frac{3.5 \times 1450}{6556} \right]^{0.2} = 0.95$$

$$\phi_{RH} = \left[ 1 + \frac{1 - H/100}{0.46\sqrt[3]{h_e/100}} \alpha_1 \right] \alpha_2 = \left[ 1 + \frac{1 - 75/100}{0.46\sqrt[3]{3/4}} 0.84 \right] 0.950 = 1.427$$

$$\beta(f_{cm_{28}}) = \frac{5.3}{\sqrt{f_{cm_{28}}/1450}} = \frac{5.3}{\sqrt{6556/1450}} = 2.49$$

$$t_0 = t_{0,T} \left[ \frac{9}{2 + t_{0,T}^{1.2}} + 1 \right] = 28 \left[ \frac{9}{2 + 28^{1.2}} + 1 \right] = 32.5 \geq 0.5 \text{ days}$$

$$\beta(t_0) = \frac{1}{0.1 + t_0^{0.2}} = \frac{1}{0.1 + 32.5^{0.2}} = 0.475$$

$$\phi_0 = \phi_{RH}\beta(f_{cm_{28}})\beta(t_0) = 1.427 \times 2.49 \times 0.475 = 1.69$$

$$\alpha_3 = \left[ \frac{3.5 \times 1450}{f_{cm_{28}}} \right]^{0.5} = \left[ \frac{3.5 \times 1450}{6556} \right]^{0.5} = 0.88$$

$$\begin{aligned} \beta_H &= 37.5h_e[1 + (0.012H)^{18}] + 250\alpha_3 \\ &= 37.5 \times 3 \times [1 + (0.012 \times 75)^{18}] + 250 \times 0.88 = 349.34 \leq 1500 \times 0.880 = 1320 \end{aligned}$$

$$\beta_c(t, t_0) = \left( \frac{t - t_0}{\beta_H + t - t_0} \right)^{0.3} = \left( \frac{35 - 28}{349.38 + 35 - 28} \right)^{0.3} = 0.308$$

$$\phi_{28}(t, t_0) = \phi_0\beta_c(t, t_0) = 1.68 \times 0.308 = 0.52$$

$$J(t, t_0) = \frac{1}{E_{cm_{t_0}}} + \frac{\phi(t, t_0)}{E_{cm_{28}}} = \frac{1}{5,156,356} + \frac{0.52}{5,156,356} = 0.295 \times 10^{-6} \text{ psi}^{-1}$$

### Example 2.6 (in.-lb Units)

Use the fib MC 2010 model to calculate the shrinkage strain and creep compliance and coefficient for the specimen given in Example 2.1.

#### Solution

##### Shrinkage Calculation

The equations utilized by the fib MC 2010 shrinkage prediction model are similar to those of the CEB MC 90-99 model. Refer to Example 2.5 Shrinkage Calculation section for shrinkage prediction.

##### Creep Calculation

$$J(t, t_0) = \frac{1}{E_{ci}(t_0)} + \frac{\phi(t, t_0)}{E_{ci}}$$

Calculation of  $E_{ci}(t_0)$  and  $E_{ci}$ :

$$t_0 = 28 \text{ days} \Rightarrow E_{ci}(t_0) = E_{ci}$$

$$E_{ci} = 3,118,310 \sqrt[3]{\frac{f_{cm}}{1450}} = 3,118,310 \sqrt[3]{\frac{6556}{1450}} = 5,156,356 \text{ psi}$$

Calculation of  $\phi(t, t_0)$ :

$$\beta_{bc}(f_{cm}) = \frac{58.6}{(f_{cm})^{0.7}} = \frac{58.6}{(6556)^{0.7}} = 0.125$$

$$\alpha = 1 \text{ for type III cement}$$

$$t_{0,adj} = t_{0,T} \left[ \frac{9}{2 + t_{0,T}^{1.2}} + 1 \right]^\alpha \geq 0.5 \text{ days}$$

$$= 28 \cdot \left[ \frac{9}{2 + 28^{1.2}} + 1 \right]^1 = 32.5 \text{ days} \geq 0.5 \text{ days}$$

$$\begin{aligned}\beta_{bc}(t, t_0) &= \ln \left[ \left( \frac{30}{t_{0,\text{adj}}} + 0.035 \right)^2 \cdot (t - t_0) + 1 \right] \\ &= \ln \left[ \left( \frac{30}{32.5} + 0.035 \right)^2 \cdot (35 - 28) + 1 \right] = 2\end{aligned}$$

$$\phi_{bc}(t, t_0) = \beta_{bc}(f_{cm}) \cdot \beta_{bc}(t, t_0) = (0.125)(2) = 0.25$$

$$\beta_{dc}(f_{cm}) = \frac{437,333}{(f_{cm})^{1.4}} = \frac{437,333}{(6556)^{1.4}} = 1.98$$

$$\beta(RH) = \frac{\left(1 - \frac{RH}{100}\right)}{\sqrt[3]{0.1 \left(\frac{h}{4}\right)}} = \frac{\left(1 - \frac{75}{100}\right)}{\sqrt[3]{0.1 \left(\frac{3}{4}\right)}} = 0.59$$

$$\beta_{dc}(t_0) = \frac{1}{0.1 + t_{0,\text{adj}}^{0.2}} = \frac{1}{0.1 + 32.5^{0.2}} = 0.475$$

$$\gamma(t_0) = \frac{1}{2.3 + \frac{3.5}{\sqrt{t_{0,\text{adj}}}}} = \frac{1}{2.3 + \frac{3.5}{\sqrt{32.5}}} = 0.343$$

$$\alpha_{fcm} = \left(\frac{5075}{f_{cm}}\right)^{0.5} = \left(\frac{5075}{6556}\right)^{0.5} = 0.880$$

$$\begin{aligned}\beta_h &= 38.1 \cdot h + 250\alpha_{fcm} \leq 1500\alpha_{fcm} \\ &= 38.1(3) + 250(0.880) \leq 1500(0.880) \\ &\Rightarrow 334 \leq 1320\end{aligned}$$

$$\beta_{dc}(t, t_0) = \left[ \frac{(t - t_0)}{\beta_h + (t - t_0)} \right]^{\gamma(t_0)} = \left[ \frac{(35 - 28)}{334 + (35 - 28)} \right]^{0.343} = 0.264$$

$$\begin{aligned}\phi_{dc}(t, t_0) &= \beta_{dc}(f_{cm}) \cdot \beta(RH) \cdot \beta_{dc}(t_0) \cdot \beta_{dc}(t, t_0) \\ &= (1.98)(0.59)(0.475)(0.264) = 0.146\end{aligned}$$

$$\begin{aligned}\phi(t, t_0) &= \phi_{bc}(t, t_0) + \phi_{dc}(t, t_0) \\ &= 0.25 + 0.146 = 0.396\end{aligned}$$

$$\begin{aligned}J(t, t_0) &= \frac{1}{E_{ci}(t_0)} + \frac{\phi(t, t_0)}{E_{ci}} \\ &= \frac{1}{5,156,356} + \frac{0.396}{5,156,356} = 0.271 \times 10^{-6} \text{ psi}^{-1}\end{aligned}$$

**Example 2.7 (in.-lb Units)**

Using the AASHTO model, calculate the shrinkage strain and creep compliance and coefficient for the specimen given in Example 2.1.

**Solution***Shrinkage Calculation*

For moist-cured concrete,  $\epsilon_{sh}$  should be taken as

$$\epsilon_{sh} = K_s K_{hs} K_f K_{td} (0.48 \times 10^{-3})$$

Determination of  $K_s$ :

$$\begin{aligned} K_s &= \left[ \frac{t / (26e^{0.36(V/S)} + t)}{t / (45 + t)} \right] \left[ \frac{1064 - 94(V/S)}{923} \right] \\ &= \left[ \frac{35 / (26e^{0.36(1.5)} + 35)}{35 / (45 + 35)} \right] \left[ \frac{1064 - 94(1.5)}{923} \right] = 1.005 \end{aligned}$$

Determination of  $K_{hs}$ :

For  $H = 75\%$ ,

$$K_{hs} = 2.00 - 0.014H = 0.95$$

Determination of  $K_f$ :

Let  $f'_{ci} = f'_c = 6556$  psi

$$K_f = \frac{5}{1 + f_{ci}}$$

$F_{ci} = 6556$  psi (at time of initial loading =  $t_a = 28$  days)

$$K_f = \frac{5}{1 + 6.556} = 0.66$$

Calculation of  $K_{td}$ :

$$K_{td} = \frac{t}{61 - 4f'_{ci} + t} = \frac{35}{61 - 4(6556) + 35} = 0.50$$

$$\epsilon_{sh} = (1.005)(0.95)(0.66)(0.50)(0.48 \times 10^{-3}) = 151.2 \times 10^{-6} \text{ in./in.}$$

*Creep Calculation*

The creep coefficient should be taken as

$$\psi(t, t_0) = 1.9K_s K_{hc} K_f K_{td} t_0^{-0.118}$$

Values of  $k_{td}$  and  $k_f$  are same as shrinkage calculation.

Determination of  $k_s$ :

$$\begin{aligned} k_s &= 1.45 - 0.13 \left( \frac{V}{S} \right) \geq 1.0 \\ &= 1.45 - 0.13(1.5) = 1.26 \end{aligned}$$

Determination of  $k_{hc}$ :

$$k_{hc} = 1.56 - 0.008H = 1.56 - 0.008(75) = 0.96$$

Calculation of  $\psi(t, t_0)$ :

$$\psi(t, t_0) = 1.9(1.26)(0.96)(0.66)(0.50)(28)^{-0.118} = 0.512$$

Determination of  $E_c$ :

$$\omega_c = 2405 \text{ kg/m}^3 = 0.145 \text{ Kcf}$$

$$E_c = 33000 \omega_c^{1.5} \sqrt{f'_c}$$

$$E_c = 4665.4 \text{ ksi}$$

Calculation of  $J(t, t_0)$ :

$$\begin{aligned} J(t, t_0) &= \frac{1}{E_c} + \frac{\psi(t, t_0)}{E_c} \\ &= \frac{1}{4665.4} + \frac{0.512}{4665.4} = 324 \times 10^{-6} \text{ psi}^{-1} \end{aligned}$$

### Example 2.8 (SI Units)

Calculate the shrinkage strain and creep compliance and coefficient for the concrete specimen given below. Use the ACI 209R-92 model.

Given factors:

Humidity = 75%

$h_e = 2V/S = 2Ac/u = 76 \text{ mm}$

$f_{cm_{28}} = 45.2 \text{ MPa}$

$w = 207.92 \text{ kg/m}^3$

$w/c = 0.46$

$a/c = 3.73$

$t = 35 \text{ days}$

$t_0 = 28 \text{ days}$

$t_c = 8 \text{ days}$

$\gamma = 2405 \text{ kg/m}^3$

Cement type III

Moist-cured concrete

### Solution

*Shrinkage Calculation*

$$\begin{aligned} \epsilon_{sh}(t, t_c) &= \frac{t - t_c}{f + (t - t_c)} K_{ss} K_{sh} \epsilon_{shu} \\ \epsilon_{shu} &= 780 \times 10^{-6} \text{ mm/mm} \end{aligned}$$

According to Table 2.4,  $f = 35$ .

$$\frac{V}{S} = 38 \text{ mm}$$

$$K_{ss} = 1.23 - 0.006 \left( \frac{V}{S} \right) = 1.23 - 0.006(38) = 1.002$$

For  $H = 75\%$ ,

$$K_{sh} = 1.40 - 0.01H = 1.40 - 0.01(75) = 0.65$$

$$\begin{aligned} \epsilon_{sh}(t, t_c) &= \frac{t - t_c}{f + (t - t_c)} K_{ss} K_{sh} \epsilon_{shu} \\ &= \frac{35 - 8}{35 + (35 - 8)} (1.002)(0.65)(780 \times 10^{-6}) = 221.3 \times 10^{-6} \text{ mm/mm} \end{aligned}$$

*Creep Calculation*

$$J(t, t_0) = \frac{1 + C_c(t)}{E_{cmt_0}}$$

Determination of  $E_{cm_{t_0}}$ :

$$a = 2.30 \quad b = 0.92 \quad (\text{Table 2.5})$$

$$f'_c(t_0) = f_{cm_{28}} \frac{t_0}{a + bt_0} = 45.2 \frac{28}{2.3 + 0.92 \times 28} = 45.1 \text{ MPa}$$

$$E_{cm_{t_0}} = 0.043(\gamma)^{3/2} \sqrt{f'_c(t_0)} = 0.043(2405)^{3/2} \sqrt{45.1} = 34058.8 \text{ MPa}$$

Determination of  $C_c(t)$ :

$$C_{cu} = 2.35$$

$$K_{ch} = 1.27 - 0.0067(H) = 1.27 - 0.0067(75) = 0.768$$

$$K_{ca} = 1.25(t_0)^{-0.118} = 1.25(28)^{-0.118} = 0.844$$

$$K_{cs} = 1.14 - 0.0035 \left( \frac{V}{S} \right) = 1.14 - 0.0035(38) = 1.007$$

$$C_c(t) = \frac{(t - t_0)^{0.60}}{10 + (t - t_0)^{0.60}} C_{cu} K_{ch} K_{ca} K_{cs} = \frac{(35 - 28)^{0.60}}{10 + (35 - 28)^{0.60}} 2.35 \times 0.768 \times 0.844 \times 1.00 = 0.37$$

$$J(t, t_0) = \frac{1 + C_c(t)}{E_{cm_{t_0}}} = \frac{1 + 0.37}{34058.8} = 40.2 \times 10^{-6} \text{ MPa}^{-1}$$

### Example 2.9 (SI Units)

Using the B3 model, calculate the shrinkage strain and creep function for the specimen given in Example 2.8.

#### Solution

*Shrinkage Calculation*

$$\varepsilon_s(t) = (\varepsilon_{shu})(K_h)S(t)$$

Determination of  $\varepsilon_{shu}$ :

$$\alpha_1 = 1.10 \quad (\text{Table 2.8})$$

$$\alpha_2 = 1.0 \quad (\text{Table 2.9})$$

$$\varepsilon_{shu} = -\varepsilon_{su} \frac{E_{cm607}}{E_{cm(t_c + \tau_{sh})}}$$

$$\begin{aligned} \varepsilon_{su} &= -\alpha_1 \alpha_2 [0.019(w)^{2.1} (f_{cm_{28}})^{-0.28} + 270] \times 10^{-6} \\ &= -(1.10)(1.0)[0.019(207.92)^{2.1} (45.2)^{-0.28} + 270] \times 10^{-6} = -827 \times 10^{-6} \text{ mm/mm} \end{aligned}$$

$$E_{cm_{28}} = 4735 \sqrt{f_{cm_{28}}} = 4735 \sqrt{45.2} = 31833.9 \text{ MPa}$$

$$k_s = 1.0$$

(Since the type of member is not defined)

$$T_{sh} = 0.085(t_c)^{-0.08} (f_{cm_{28}})^{-0.25} \left[ 2k_s \left( \frac{V}{S} \right) \right]^2$$

$$T_{sh} = 0.085(8)^{-0.08} (45.2)^{-0.25} [2(1)(38)]^2$$

$$= 160.3 \text{ days}$$



$$\begin{aligned}
E_{\text{cm}607} &= (1.167)^{1/2} E_{\text{cm}28} \\
&= (1.167)^{1/2} (31833.9) = 34389.5 \text{ MPa} \\
E_{\text{cm}(t_c+\tau_{\text{sh}})} &= \left( \frac{t_c + \tau_{\text{sh}}}{4 + 0.85(t_c + \tau_{\text{sh}})} \right)^{1/2} E_{\text{cm}28} = \left( \frac{8 + 160.3}{4 + 0.85(8 + 160.3)} \right)^{1/2} (31833.9) \\
&= 34055.9 \text{ MPa} \\
\varepsilon_{\text{shu}} &= -\varepsilon_{\text{su}} \frac{E_{\text{cm}607}}{E_{\text{cm}(t_c+\tau_{\text{sh}})}} = -(-827 \times 10^{-6}) \frac{34389.5}{34055.9} = 835.1 \times 10^{-6} \text{ mm/mm}
\end{aligned}$$

Determination of  $K_h$ :

According to the Table 2.10, for  $H = 75\%$

$$K_h = 1 - \left( \frac{H}{100} \right)^3 = 1 - \left( \frac{75}{100} \right)^3 = 0.578$$

Determination of  $S(t)$ :

$$S(t) = \tanh \sqrt{\frac{t - t_c}{T_{\text{sh}}}} = \tanh \sqrt{\frac{35 - 8}{160.3}} = 0.389$$

$$\varepsilon_s(t) = (\varepsilon_{\text{shu}})(K_h)S(t) = (835.1 \times 10^{-6})(0.578)(0.389) = 187.8 \times 10^{-6} \text{ mm/mm}$$

*Creep Calculation:*

$$J(t, t_0) = q_1 + C_0(t, t_0) + C_d(t, t_0, t_c)$$

Determination of  $q_1$ :

$$q_1 = \frac{0.6}{E_{\text{cm}28}} = \frac{0.6}{31833.9} = 18.85 \times 10^{-6} \text{ MPa}^{-1}$$

Calculation of  $C_0(t, t_0)$ :

$$c = \frac{w}{w/c} = \frac{207.92}{0.46} = 452 \text{ kg/m}^3$$

$$\begin{aligned}
q_2 &= 185.4(c)^{0.5}(f_{\text{cm}28})^{-0.9} \times 10^{-6} = 185.4(452)^{0.5}(45.2)^{-0.9} \times 10^{-6} \\
&= 127.7 \times 10^{-6}
\end{aligned}$$

$$Q_f(t_0) = \frac{1}{0.086(t_0)^{2/9} + 1.21(t_0)^{4/9}} = \frac{1}{0.086(28)^{2/9} + 1.21(28)^{4/9}} = 0.182$$

$$Z(t, t_0) = \frac{\ln[1 + (t - t_0)^{0.1}]}{\sqrt{t_0}} = \frac{\ln[1 + (35 - 28)^{0.1}]}{\sqrt{28}} = 0.150$$

$$r(t_0) = 1.7(t_0)^{0.12} + 8 = 1.7(28)^{0.12} + 8 = 10.54$$

$$Q(t, t_0) = Q_f(t_0) \left[ 1 + \frac{Q_f(t_0)^{r(t_0)}}{Z(t, t_0)^{r(t_0)}} \right]^{-1/r(t_0)} = 0.182 \left[ 1 + \frac{0.182^{10.54}}{0.150^{10.54}} \right]^{-1/10.54} = 0.148$$

$$q_3 = 0.29q_2 \left( \frac{w}{c} \right)^4 = 0.29(127.7 \times 10^{-6})(0.46)^4 = 1.66 \times 10^{-6}$$

$$q_4 = 20.3 \left( \frac{a}{c} \right)^{-0.7} \times 10^{-6} = 20.3(3.73)^{-0.7} \times 10^{-6} = 8.08 \times 10^{-6}$$

$$\begin{aligned} C_0(t, t_0) &= q_2 Q(t, t_0) + q_3 \ln[1 + (t - t_0)^{0.1}] + q_4 \ln \left( \frac{t}{t_0} \right) \\ &= (127.6 \times 10^{-6})(0.148) + (1.66 \times 10^{-6}) \ln[1 + (35 - 28)^{0.1}] + (8.08 \times 10^{-6}) \ln \left( \frac{35}{28} \right) \\ &= 22.01 \times 10^{-6} \text{ MPa}^{-1} \end{aligned}$$

Calculation of  $C_d(t, t_0, t_c)$ :

$$q_5 = \frac{0.757 |\epsilon_{\text{shu}} \times 10^6|^{-0.6}}{f_{\text{cm}28}} = \frac{0.757 |835.1 \times 10^{-6} \times 10^6|^{-0.6}}{45.2} = 295.7 \times 10^{-6}$$

$$S(t) = 0.389$$

$$S(t_0) = \tanh \sqrt{\frac{t_0 - t_c}{T_{\text{sh}}}} = \tanh \sqrt{\frac{28 - 8}{160.3}} = 0.339$$

$$H(t) = 1 - \left[ \left( 1 - \frac{H}{100} \right) S(t) \right] = 1 - \left[ \left( 1 - \frac{75}{100} \right) 0.389 \right] = 0.903$$

$$H(t_0) = 1 - \left[ \left( 1 - \frac{H}{100} \right) S(t_0) \right] = 1 - \left[ \left( 1 - \frac{75}{100} \right) 0.339 \right] = 0.915$$

$$\begin{aligned} C_d(t, t_0, t_c) &= q_5 \sqrt{\exp[-8H(t)] - \exp[-8H(t_0)]} \\ &= (295.7 \times 10^{-6}) \sqrt{\exp[-8 \times 0.903] - \exp[-8 \times 0.915]} = 2.42 \times 10^{-6} \text{ MPa}^{-1} \end{aligned}$$

$$\begin{aligned} J(t, t_0) &= q_1 + C_0(t, t_0) + C_d(t, t_0, t_c) \\ &= (18.85 \times 10^{-6}) + (22.01 \times 10^{-6}) + (2.42 \times 10^{-6}) = 43.28 \times 10^{-6} \text{ MPa}^{-1} \end{aligned}$$

*Creep coefficient:*

$$c_c(t, t_0) = J(t, t_0) E_{\text{cm}28} - 1 = (43.3 \times 10^{-6})(31833.9) - 1 = 0.38$$

### Example 2.10 (SI Units)

Using the GL 2000 model, calculate the shrinkage strain and creep function for the specimen given in Example 2.8.

#### Solution

*Shrinkage Calculation:*

$$\epsilon_s(t) = \epsilon_{\text{shu}} \beta(h) \beta(t - t_c)$$

Calculation of  $\epsilon_{\text{shu}}$ :

$$K = 1.15 \text{ (Table 2.12)}$$

$$\epsilon_{\text{shu}} = (900) K \left( \frac{30}{f_{\text{cm}28}} \right)^{1/2} \times 10^{-6} = (900)(1.15) \left( \frac{30}{45.2} \right)^{1/2} \times 10^{-6} = 843.2 \times 10^{-6} \text{ mm/mm}$$

Calculation of  $\beta(h)$ :

$$\beta(h) = 1 - 1.18 \left( \frac{H}{100} \right)^4 = 1 - 1.18 \left( \frac{75}{100} \right)^4 = 0.627$$

Calculation of  $\beta(t - t_c)$ :

$$\beta(t - t_c) = \left( \frac{t - t_c}{t - t_c + 0.12(V/S)^2} \right)^{1/2} = \left( \frac{35 - 8}{35 - 8 + 0.12(38)^2} \right)^{1/2} = 0.367$$

$$\varepsilon_s(t) = \varepsilon_{shu} \beta(h) \beta(t - t_c) = (843.2 \times 10^{-6})(0.627)(0.367) = 194 \times 10^{-6} \text{ mm/mm}$$

*Creep Calculation*

$$J(t, t_0) = \frac{1}{E_{cm_{t_0}}} + \frac{\phi(t, t_0)}{E_{cm_{28}}}$$

Calculation of  $E_{cm_{t_0}}$  and  $E_{cm_{28}}$ :

$$t_0 = 28 \text{ days} \Rightarrow E_{cm_{t_0}} = E_{cm_{28}}$$

$$E_{cm_{28}} = 3500 + 4300 \sqrt{f_{cm_{28}}} = 3500 + 4300 \sqrt{45.2} = 32409.3 \text{ MPa}$$

Calculation of  $\phi(t, t_0)$ :

$$t_0 = 28 > t_c = 8 \text{ days}$$

$$\phi(t_c) = \left[ 1 - \left( \frac{t_0 - t_c}{t_0 - t_c + 0.12(V/S)^2} \right)^{0.5} \right]^{0.5} = \left[ 1 - \left( \frac{28 - 8}{28 - 8 + 0.12(38)^2} \right)^{0.5} \right]^{0.5} = 0.824$$

$$h = \frac{H}{100} = \frac{75}{100} = 0.75$$

$$\begin{aligned} \phi_{28}(t, t_0) &= \phi(t_c) \left[ 2 \left( \frac{(t - t_0)^{0.3}}{(t - t_0)^{0.3} + 14} \right) + \left( \frac{7}{t_0} \right)^{0.5} \left( \frac{t - t_0}{t - t_0 + 7} \right)^{0.5} \right. \\ &\quad \left. + 2.5(1 - 1.086h^2) \left( \frac{t - t_0}{t - t_0 + 0.12(V/S)^2} \right)^{0.5} \right] \\ &= 0.824 \left[ 2 \left( \frac{(35 - 28)^{0.3}}{(35 - 28)^{0.3} + 14} \right) + \left( \frac{7}{28} \right)^{0.5} \left( \frac{35 - 28}{35 - 28 + 7} \right)^{0.5} \right. \\ &\quad \left. + 2.5(1 - 1.086(0.75)^2) \left( \frac{35 - 28}{35 - 28 + 0.12(38)^2} \right)^{0.5} \right] = 0.636 \end{aligned}$$

$$J(t, t_0) = \frac{1}{E_{cm_{t_0}}} + \frac{\phi_{28}(t, t_0)}{E_{cm_{28}}} = \frac{1}{32409.3} + \frac{0.636}{32409.3} = 50.5 \times 10^{-6} \text{ MPa}^{-1}$$

### Example 2.11 (SI Units)

Using the CEB 90 model, calculate the shrinkage strain and creep function for the specimen given in Example 2.8.

**Solution***Shrinkage Calculation*

$$\varepsilon_s(t, t_c) = (\varepsilon_{cs_0})\beta_s(t, t_c)$$

Calculation of  $\varepsilon_{cs_0}$ :

$$\begin{aligned}\beta_{sc} &= 8 \\ \varepsilon_s(f_{cm_{28}}) &= \left[ 160 + 10(\beta_{sc}) \left( 9 - \frac{f_{cm_{28}}}{10} \right) \right] \times 10^{-6} \\ &= \left[ 160 + 10(8) \left( 9 - \frac{45.2}{10} \right) \right] \times 10^{-6} = 518.4 \times 10^{-6} \text{ mm/mm}\end{aligned}$$

For  $H = 75\%$ ,

$$\begin{aligned}\beta_{RH} &= -1.55\beta_{arh} \\ \beta_{arh} &= 1 - \left( \frac{H}{100} \right)^3 = 1 - \left( \frac{75}{100} \right)^3 = 0.578 \\ \beta_{RH} &= -1.55\beta_{arh} = -1.55 \times 0.578 = -0.896 \\ \varepsilon_{cs_0} &= \varepsilon_s(f_{cm_{28}})(\beta_{RH}) = (518.4 \times 10^{-6})(-0.896) = -464.5 \times 10^{-6} \text{ mm/mm}\end{aligned}$$

Calculation of  $\beta_s(t - t_c)$ :

$$\begin{aligned}h_e &= \frac{2A_c}{u} = 76 \text{ mm} \\ \beta_s(t - t_c) &= \sqrt{\frac{t - t_c}{0.56(h_e/4)^2 + (t - t_c)}} = \sqrt{\frac{35 - 8}{0.56(76/4)^2 + (35 - 8)}} = 0.343 \\ \varepsilon_s(t, t_c) &= (\varepsilon_{cs_0})\beta_s(t - t_c) = (-464.5 \times 10^{-6})(0.343) = -159.3 \times 10^{-6} \text{ mm/mm}\end{aligned}$$

*Creep Calculation*

$$J(t, t_0) = \frac{1}{E_{cm_{t_0}}} + \frac{\phi_{28}(t, t_0)}{E_{cm_{28}}}$$

Calculation of  $E_{cm_{t_0}}$  and  $E_{cm_{28}}$ :

$$\begin{aligned}t_0 &= 28 \text{ days} \Rightarrow E_{cm_{t_0}} = E_{cm_{28}} \\ E_{cm_{28}} &= 21,500 \sqrt[3]{\frac{f_{cm_{28}}}{10}} = 21,500 \sqrt[3]{\frac{45.2}{10}} = 35,548 \text{ MPa}\end{aligned}$$

Calculation of  $\phi(t, t_0)$ :

$$\begin{aligned}\phi_{RH} &= 1 + \frac{1 - H/100}{0.46 \sqrt[3]{h_e/100}} = 1 + \frac{1 - 75/100}{0.46 \sqrt[3]{76/100}} = 1.596 \\ \beta(f_{cm_{28}}) &= \frac{5.3}{\sqrt{f_{cm_{28}}/10}} = \frac{5.3}{\sqrt{45.2/10}} = 2.49 \\ \beta(t_0) &= \frac{1}{0.1 + t_0^{0.02}} = \frac{1}{0.1 + 28^{0.02}} = 0.488\end{aligned}$$

$$\begin{aligned}\phi_0 &= \phi_{RH}\beta(f_{cm_{28}})\beta(t_0) = (1.596)(2.49)(0.488) = 1.939 \\ \beta_H &= 1.5h_e[1 + (0.012H)^{18}] + 250 = 1.5(76)[1 + (0.012 \times 75)^{18}] + 250 \\ &= 381 \leq 1500 \text{ days} \\ \beta_c(t, t_0) &= \left(\frac{t - t_0}{\beta_H + t - t_0}\right)^{0.3} = \left(\frac{35 - 28}{381 + 35 - 28}\right)^{0.3} = 0.3 \\ \phi(t, t_0) &= \phi_0\beta_c(t, t_0) = 1.939 \times 0.3 = 0.582 \\ J(t, t_0) &= \frac{1}{E_{cm_{t_0}}} + \frac{\phi(t, t_0)}{E_{cm_{28}}} = \frac{1}{35,548} + \frac{0.582}{35,548} = 44.5 \times 10^{-6} \text{ MPa}^{-1}\end{aligned}$$


---

**Example 2.12 (SI Units)**

Use the CEB MC 90–99 model to calculate the shrinkage strain and creep function for the specimen given in Example 2.8.

**Solution***Shrinkage Calculation*

$$\varepsilon_s(t, t_c) = \varepsilon_{as}(t) + \varepsilon_{ds}(t, t_c)$$

Calculation of  $\varepsilon_{as}(t)$ :

$$\alpha_{as} = 600 \text{ for rapidly hardening high – strength cements}$$

$$\begin{aligned}\varepsilon_{as_0}(f_{cm_{28}}) &= -\alpha_{as} \left(\frac{f_{cm_{28}}/10}{6 + f_{cm_{28}}/10}\right)^{2.5} \times 10^{-6} \\ &= -600 \left(\frac{45.2/10}{6 + 45.2/10}\right)^{2.5} \times 10^{-6} = -72.6 \times 10^{-6} \text{ mm/mm}\end{aligned}$$

$$\beta_{as}(t) = 1 - \exp(-0.2(t)^{0.5}) = 1 - \exp(-0.2(35)^{0.5}) = 0.694$$

$$\varepsilon_{as}(t) = \varepsilon_{as_0}(f_{cm_{28}})\beta_{as}(t) = (-72.6 \times 10^{-6})(0.694) = -50.4 \times 10^{-6} \text{ mm/mm}$$

Calculation of  $\varepsilon_{ds}(t, t_c)$ :

$$\alpha_{ds_1} = 6 \text{ for rapidly hardening high – strength cements}$$

$$\alpha_{ds_2} = 0.12 \text{ for rapidly hardening high – strength cements}$$

$$\begin{aligned}\varepsilon_{ds_0}(f_{cm_{28}}) &= [(220 + 110\alpha_{ds_1})\exp(-\alpha_{ds_2}f_{cm_{28}}/10)] \times 10^{-6} \\ &= [(220 + 110 \times 6)\exp(-0.12 \times 45.2/10)] \times 10^{-6} = 511.6 \times 10^{-6} \text{ mm/mm}\end{aligned}$$

$$\beta_{s1} = \left(\frac{35}{f_{cm_{28}}}\right)^{0.1} = \left(\frac{35}{45.2}\right)^{0.1} = 0.97 \leq 1.0$$

For  $40\% < H = 75\% < 99\%$   $(0.97) = 96.5\%$ ,

$$\beta_{RH} = -1.55 \left[1 - \left(\frac{H}{100}\right)^3\right] = -1.55 \left[1 - \left(\frac{75}{100}\right)^3\right] = -0.896$$

$$\begin{aligned}\beta_{ds}(t-t_c) &= \left( \frac{t-t_c}{350(h_e/100)^2 + (t-t_c)} \right)^{0.5} \\ &= \left( \frac{35-8}{350(76/100)^2 + (35-8)} \right)^{0.5} = 0.343\end{aligned}$$

$$\begin{aligned}\varepsilon_{ds}(t, t_c) &= \varepsilon_{ds_0}(f_{cm_{28}})\beta_{RH}(H)\beta_{ds}(t-t_c) \\ &= (511.6 \times 10^{-6})(-0.896)(0.343) = -157.2 \times 10^{-6} \text{ mm/mm}\end{aligned}$$

$$\varepsilon_s(t, t_c) = \varepsilon_{as}(t) + \varepsilon_{ds}(t, t_c) = (-50.4 \times 10^{-6}) + (-157.2 \times 10^{-6}) = -207.6 \times 10^{-6} \text{ mm/mm}$$

*Creep Calculation*

$$J(t, t_0) = \frac{1}{E_{cmt_0}} + \frac{\phi_{28}(t, t_0)}{E_{cm_{28}}}$$

Calculation of  $E_{cmt_0}$  and  $E_{cm_{28}}$ :

$$t_0 = 28 \text{ days} \Rightarrow E_{cmt_0} = E_{cm_{28}}$$

$$E_{cm_{28}} = 21,500 \sqrt[3]{\frac{f_{cm_{28}}}{10}} = 21,500 \sqrt[3]{\frac{45.2}{10}} = 35,548 \text{ MPa}$$

Calculation of  $\varphi(t, t_0)$ :

$$\alpha_1 = \left[ \frac{35}{f_{cm_{28}}} \right]^{0.7} = \left[ \frac{35}{45.2} \right]^{0.7} = 0.836$$

$$\alpha_2 = \left[ \frac{35}{f_{cm_{28}}} \right]^{0.2} = \left[ \frac{35}{45.2} \right]^{0.2} = 0.950$$

$$\phi_{RH} = \left[ 1 + \frac{1-H/100}{0.46 \sqrt[3]{h_e/100}} \alpha_1 \right] \alpha_2 = \left[ 1 + \frac{1-75/100}{0.46 \sqrt[3]{76/100}} 0.836 \right] 0.950 = 1.423$$

$$\beta(f_{cm_{28}}) = \frac{5.3}{\sqrt{f_{cm_{28}}/10}} = \frac{5.3}{\sqrt{45.2/10}} = 2.49$$

$$t_0 = t_{0,T} \left[ \frac{9}{2 + t_{0,T}^{1.2}} + 1 \right]^\alpha = 28 \left[ \frac{9}{2 + 28^{1.2}} + 1 \right] = 32.5 \geq 0.5 \text{ days}$$

$$\beta(t_0) = \frac{1}{0.1 + t_0^{0.2}} = \frac{1}{0.1 + 32.5^{0.2}} = 0.475$$

$$\phi_0 = \phi_{RH} \beta(f_{cm_{28}}) \beta(t_0) = 1.423 \times 2.49 \times 0.475 = 1.683$$

$$\alpha_3 = \left[ \frac{35}{f_{cm_{28}}} \right]^{0.5} = \left[ \frac{35}{45.2} \right]^{0.5} = 0.880$$

$$\beta_H = 1.5h_e[1 + (0.012H)^{18}] + 250\alpha_3$$

$$= 1.5 \times 76 \times [1 + (0.012 \times 75)^{18}] + 250 \times 0.88 = 351 \leq 1500 \times 0.880 = 1320$$

$$\beta_c(t, t_0) = \left( \frac{t - t_0}{\beta_H + t - t_0} \right)^{0.3} = \left( \frac{35 - 28}{351 + 35 - 28} \right)^{0.3} = 0.307$$

$$\phi(t, t_0) = \phi_0 \beta_c(t, t_0) = 1.683 \times 0.307 = 0.517$$

$$J(t, t_0) = \frac{1}{E_{cmt_0}} + \frac{\phi(t, t_0)}{E_{cm_{28}}} = \frac{1}{35,548} + \frac{0.517}{35,548} = 42.68 \times 10^{-6} \text{ MPa}^{-1}$$

**Example 2.13 (SI Units)**

Use the fib MC 2010 model to calculate the shrinkage strain and creep function for the specimen given in Example 2.8.

**Solution***Shrinkage Calculation*

The equations utilized by the fib MC 2010 shrinkage prediction model are similar to those of the CEB MC 90-99 model. Refer to Example 2.12 Shrinkage Calculation section for shrinkage prediction.

*Creep Calculation*

$$J(t, t_0) = \frac{1}{E_{ci}(t_0)} + \frac{\phi(t, t_0)}{E_{ci}}$$

Calculation of  $E_{ci}(t_0)$  and  $E_{ci}$ :

$$t_0 = 28 \text{ days} \Rightarrow E_{ci}(t_0) = E_{ci}$$

$$E_{ci} = 21,500 \sqrt[3]{\frac{f_{cm_{28}}}{10}} = 21,500 \sqrt[3]{\frac{45.2}{10}} = 35,548 \text{ MPa}$$

Calculation of  $\varphi(t, t_0)$ :

$$\beta_{bc}(f_{cm}) = \frac{1.8}{(f_{cm})^{0.7}} = \frac{1.8}{(45.2)^{0.7}} = 0.125$$

$$\alpha = 1 \text{ for type III cement}$$

$$t_{0,adj} = t_{0,T} \left[ \frac{9}{2 + t_{0,T}^{1.2}} + 1 \right]^\alpha \geq 0.5 \text{ days}$$

$$= 28 \cdot \left[ \frac{9}{2 + 28^{1.2}} + 1 \right]^1 = 32.5 \text{ days} \geq 0.5 \text{ days}$$

$$\begin{aligned} \beta_{bc}(t, t_0) &= \ln \left[ \left( \frac{30}{t_{0,adj}} + 0.035 \right)^2 \cdot (t - t_0) + 1 \right] \\ &= \ln \left[ \left( \frac{30}{32.5} + 0.035 \right)^2 \cdot (35 - 28) + 1 \right] = 2 \end{aligned}$$

$$\phi_{bc}(t, t_0) = \beta_{bc}(f_{cm}) \cdot \beta_{bc}(t, t_0) = (0.125)(2) = 0.25$$

$$\beta_{dc}(f_{cm}) = \frac{412}{(f_{cm})^{1.4}} = \frac{412}{(45.2)^{1.4}} = 1.98$$

$$\beta(RH) = \frac{\left(1 - \frac{RH}{100}\right)}{\sqrt[3]{0.1 \cdot \frac{h}{100}}} = \frac{\left(1 - \frac{75}{100}\right)}{\sqrt[3]{0.1 \cdot \frac{76}{100}}} = 0.59$$

$$\beta_{dc}(t_0) = \frac{1}{0.1 + t_{0,adj}^{0.2}} = \frac{1}{0.1 + 32.5^{0.2}} = 0.475$$

$$\gamma(t_0) = \frac{1}{2.3 + \frac{3.5}{\sqrt{t_{0,adj}}}} = \frac{1}{2.3 + \frac{3.5}{\sqrt{32.5}}} = 0.343$$

$$\alpha_{fcm} = \left(\frac{35}{f_{cm}}\right)^{0.5} = \left(\frac{35}{45.2}\right)^{0.5} = 0.880$$

$$\begin{aligned}\beta_h &= 1.5 \cdot h + 250 \cdot \alpha_{fcm} \leq 1500 \cdot \alpha_{fcm} \\ &= 1.5 \cdot (76) + 250 \cdot (0.880) \leq 1500 \cdot (0.880) \\ &\Rightarrow 334 \leq 1320\end{aligned}$$

$$\beta_{dc}(t, t_0) = \left[\frac{(t - t_0)}{\beta_h + (t - t_0)}\right]^{\gamma(t_0)} = \left[\frac{(35 - 28)}{334 + (35 - 28)}\right]^{0.343} = 0.264$$

$$\begin{aligned}\phi_{dc}(t, t_0) &= \beta_{dc}(f_{cm}) \cdot \beta(RH) \cdot \beta_{dc}(t_0) \cdot \beta_{dc}(t, t_0) \\ &= (1.98)(0.59)(0.475)(0.264) = 0.146\end{aligned}$$

$$\begin{aligned}\phi(t, t_0) &= \phi_{bc}(t, t_0) + \phi_{dc}(t, t_0) \\ &= 0.25 + 0.146 = 0.396\end{aligned}$$

$$\begin{aligned}J(t, t_0) &= \frac{1}{E_{ci}(t_0)} + \frac{\phi(t, t_0)}{E_{ci}} \\ &= \frac{1}{35,548} + \frac{0.396}{35,548} = 39.27 \times 10^{-6} \text{ MPa}^{-1}\end{aligned}$$

### Example 2.14 (SI Units)

Using the AASHTO model, calculate the shrinkage strain and creep function for the specimen given in Example 2.8.

#### Solution

##### Shrinkage Calculation

For moist-cured concrete,  $\epsilon_{sh}$  should be taken as

$$\epsilon_{sh} = K_s K_{hs} K_f K_{td} (0.48 \times 10^{-3})$$

Determination of  $K_s$ :

$$\begin{aligned}K_s &= \left[ \frac{t / (26e^{0.0142(V/S)} + t)}{t / (45 + t)} \right] \left[ \frac{1064 - 3.7(V/S)}{923} \right] \\ &= \left[ \frac{35 / (26e^{0.014(38)} + 35)}{35 / (45 + 35)} \right] \left[ \frac{1064 - 3.7(38)}{923} \right] = 1.009 \approx 1.00\end{aligned}$$

Determination of  $K_{hs}$ :

For  $H = 75\%$ ,

$$K_{hs} = [2.00 - 0.014H] = 0.95$$



Determination of  $K_f$ :

$$K_f = \frac{35}{7 + f_{ci}} = 0.95$$

$f_{ci} = 45.2$  MPa (at time of initial loading =  $t_a = 28$  days)

$$K_f = \frac{35}{7 + 45.2} = 0.67$$

Calculation of  $K_{td}$ :

$$K_{td} = \left( \frac{t}{61 - 0.58f'_{ci} + t} \right) = \left( \frac{35}{61 - 0.58(45.2) + 35} \right) = 0.50$$

$$\varepsilon_{sh} = (1.0)(0.95)(0.67)(0.50)(0.48 \times 10^{-3}) = 153 \times 10^{-6} \text{ mm/mm}$$

### Creep Calculation

The creep coefficient should be taken as

$$\psi(t, t_0) = 1.9K_sK_{hc}K_fK_{td}t_0^{-0.118}$$

Values of  $k_{td}$  and  $k_f$  are same as shrinkage calculation.

Determination of  $k_s$ :

$$k_s = 1.45 - 0.005 \left( \frac{V}{S} \right) \geq 1.0$$

$$= 1.45 - 0.005(38) = 1.26$$

Determination of  $k_{hc}$ :

$$k_{hc} = 1.56 - 0.008H = 1.56 - 0.008(75) = 0.96$$

Calculation of  $\psi(t, t_0)$ :

$$\psi(t, t_0) = 1.9(1.26)(0.96)(0.67)(0.50)(28)^{-0.118} = 0.52$$

Determination of  $E_c$ :

$$\omega_c = 240 \text{ kg/m}^3 = 0.15 \text{ Kcf}$$

$$E_c = 0.043(2405)^{1.5} \sqrt{45.2}$$

$$= 34,097 \text{ MPa}$$

Calculation of  $J(t, t_0)$ :

$$J(t, t_0) = \frac{1}{E_c} + \frac{\psi(t, t_0)}{E_c}$$

$$= \frac{1}{34,096} + \frac{0.52}{34,097} = 44.6 \times 10^{-6} \text{ MPa}^{-1}$$

## 2.14 UNIT WEIGHT OF CONCRETE

The unit weight,  $w$ , of hardened normal concrete ordinarily used in buildings and similar structures depends on the concrete mix, maximum size and grading of aggregates, water–cement ratio, and strength of concrete. The following values of the unit weight of concrete may be used:

1. Unit weight of plain concrete using maximum aggregate size of  $\frac{3}{4}$  in. (20 mm) varies between 145 and 150 lb/ft<sup>3</sup> (2320 to 2400 kg/m<sup>3</sup>). For concrete of strength less than 4000 psi

(280 kg/cm<sup>2</sup>), a value of 145 lb/ft<sup>3</sup> (2320 kg/m<sup>3</sup>) can be used, whereas for higher strength concretes,  $w$  can be assumed to be equal to 150 lb/ft<sup>3</sup> (2400 kg/m<sup>3</sup>).

2. Unit weight of plain concrete of maximum aggregate size of 4 to 6 in. (100 to 150 mm) varies between 150 and 160 lb/ft<sup>3</sup> (2400 to 2560 kg/m<sup>3</sup>). An average value of 155 lb/ft<sup>3</sup> may be used.
3. Unit weight of reinforced concrete, using about 0.7 to 1.5% of steel in the concrete section, may be taken as 150 lb/ft<sup>3</sup> (2400 kg/m<sup>3</sup>). For higher percentages of steel, the unit weight,  $w$ , can be assumed to be 155 lb/ft<sup>3</sup> (2500 kg/m<sup>3</sup>).
4. Unit weight of lightweight concrete used for fireproofing, masonry, or insulation purposes varies between 20 and 90 lb/ft<sup>3</sup> (320 and 1440 kg/m<sup>3</sup>). Concrete of upper values of 90 pcf or greater may be used for load-bearing concrete members.

The unit weight of heavy concrete varies between 200 and 270 lb/ft<sup>3</sup> (3200 and 4300 kg/m<sup>3</sup>). Heavy concrete made with natural barite aggregate of 1½ in. maximum size (38 mm) weighs about 225 lb/ft<sup>3</sup> (3600 kg/m<sup>3</sup>). Iron ore sand and steel-punchings aggregate produce a unit weight of 270 lb/ft<sup>3</sup> (4320 kg/m<sup>3</sup>) [20].

## 2.15 FIRE RESISTANCE

Fire resistance of a material is its ability to resist fire for a certain time without serious loss of strength, distortion, or collapse [21]. In the case of concrete, fire resistance depends on the thickness, type of construction, type and size of aggregates, and cement content. It is important to consider the effect of fire on tall buildings more than on low or single-story buildings because occupants need more time to escape.

Reinforced concrete is a much better fire-resistant material than steel. Steelwork heats rapidly, and its strength drops appreciably in a short time. Concrete itself has low thermal conductivity. The effect of temperatures below 250°C is small on concrete, but definite loss is expected at higher temperatures.

## 2.16 HIGH-PERFORMANCE CONCRETE

High-performance concrete may be assumed to imply that the concrete exhibits combined properties of strength, toughness, energy absorption, durability, stiffness, and a relatively higher ductility than normal concrete. This improvement in concrete quality may be achieved by using a new generation of additives and superplasticizers, which improves the workability of concrete and, consequently, its strength. Also, the use of active microfillers such as silica fume, fly ash, and polymer improves the strength, porosity, and durability of concrete. The addition of different types of fiber to the concrete mix enhances many of its properties, including ductility, strength, and toughness.

Because it is difficult to set a limit to measure high-performance concrete, one approach is to define a lower bound limit based on the shape of its stress–strain response in tension [22]. If the stress–strain relationship curve shows a quasi-strain-hardening behavior—or, in other words, a postcracking strength larger than the cracking strength with an elastic-plastic behavior—then high performance is achieved [22]. In this behavior, multicracking stage is reached with high energy-absorption capacity. Substantial progress has been made recently in understanding the behavior and practical application of high-performance concrete.



Casting and finishing precast concrete wall panels.

## 2.17 LIGHTWEIGHT CONCRETE

Lightweight concrete has been made lighter than conventional normal-weight concrete and, consequently, it has a relatively lower density. Basically, reducing the density requires the inclusion of air in the concrete composition. This, however, can be achieved in four distinct ways:

1. By omitting the finer sizes from the aggregate grading, thereby creating what is called *no-fines* concrete. It is a mixture of cement, water, and coarse aggregate only  $\left(\frac{3}{4} - \frac{3}{8}\right)$ , mixed to produce concrete with many uniformly distributed voids.
2. By replacing the gravel or crushed rock aggregate with a hollow cellular or porous aggregate, which includes air in the mix. This type is called *lightweight aggregate concrete*. Lightweight aggregate may be natural, such as pumice, pozzolans, and volcanic slags; artificial (from industrial by-products), such as furnace clinker and foamed slag; or industrially produced, such as perlite, vermiculite, expanded clay, shale, and slate.

3. By creating gas bubbles in a cement slurry, which, when it sets, leaves a spongelike structure. This type is called *aerated concrete*.
4. By forming air cells in the slurry by chemical reaction or by vigorous mixing of the slurry with a preformed stable foam, which is produced by using special foam concentrate in a high-speed mixer. This type is called *cellular concrete*.

Structural lightweight concrete has a unit weight that ranges from 90 to 115 lb/ft<sup>3</sup>, compared with 145 lb/ft<sup>3</sup> for normal-weight concrete. It is used in the design of floor slabs in buildings and other structural members where high-strength concrete is not required. Structural lightweight concrete can be produced with a compressive strength of 2500 to 5000 psi for practical applications.

## 2.18 FIBROUS CONCRETE

Fibrous concrete is made primarily of concrete constituents and discrete reinforcing fibers. The brittle nature of concrete and its low flexural tensile strength are major reasons for the growing interest in the performance of fibers in concrete technology. Various types of fibers—mainly steel, glass, and organic polymers—have been used in fibrous concrete. Generally, the length and diameter of the fibers do not exceed 3 in. (75 mm) and 0.04 in. (1 mm), respectively. The addition of fibers to concrete improves its mechanical properties, such as ductility, toughness, shear, flexural strength, impact resistance, and crack control. A convenient numerical parameter describing a fiber is its aspect ratio, which is the fiber length divided by an equivalent fiber diameter. Typical aspect ratios range from about 30 to 150, with the most common ratio being about 100. More details on fibrous concrete are given in Reference 23.

## 2.19 STEEL REINFORCEMENT

Reinforcement, usually in the form of steel bars, is placed in the concrete member, mainly in the tension zone, to resist the tensile forces resulting from external load on the member. Reinforcement is also used to increase the member's compression resistance. Steel costs more than concrete, but it has a yield strength about 10 times the compressive strength of concrete. The function and behavior of both steel and concrete in a reinforced concrete member are discussed in Chapter 3.

Longitudinal bars taking either tensile or compression forces in a concrete member are called *main reinforcement*. Additional reinforcement in slabs, in a direction perpendicular to the main reinforcement, is called *secondary*, or *distribution*, *reinforcement*. In reinforced concrete beams, another type of steel reinforcement is used, transverse to the direction of the main steel and bent in a box or U shape. These are called *stirrups*. Similar reinforcements are used in columns, where they are called *ties*.

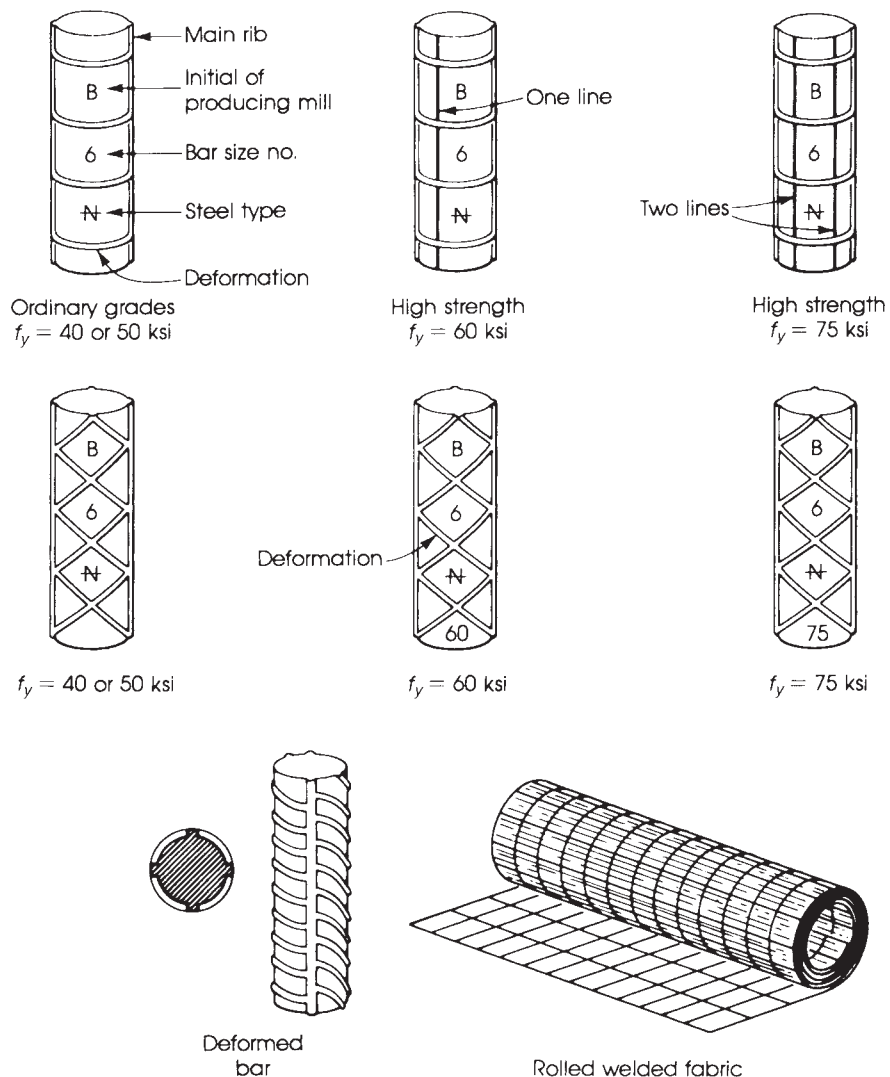
### 2.19.1 Types of Steel Reinforcement

Different types of steel reinforcement are used in various reinforced concrete members. These types can be classified as follows:

**Round Bars.** Round bars are used most widely for reinforced concrete. Round bars are available in a large range of diameters, from  $\frac{1}{4}$  in. (6 mm) to  $1\frac{3}{8}$  in. (36 mm), plus two special types,  $1\frac{3}{4}$  in. (45 mm) and  $2\frac{1}{4}$  in. (57 mm). Round bars, depending on their surfaces, are either plain or deformed bars. Plain bars are used mainly for secondary reinforcement or in stirrups and ties. Deformed bars

have projections or deformations on the surface for the purpose of improving the bond with concrete and reducing the width of cracks opening in the tension zone.

The diameter of a plain bar can be measured easily, but for a deformed bar, a nominal diameter is used that is the diameter of a circular surface with the same area as the section of the deformed bar. Requirements of surface projections on bars are specified by ASTM specification A 305 or A 615. The bar sizes are designated by numbers 3 through 11, corresponding to the diameter in one-eighths of an inch. For instance, a no. 7 bar has a nominal diameter of  $\frac{7}{8}$  in. and a no. 4 bar has a nominal diameter of  $\frac{1}{2}$  in. The two largest sizes are designated no. 14 and no. 18, respectively. American standard bar marks are shown on the steel reinforcement to indicate the initial of the producing mill, the bar size, and the type of steel (Fig. 2.6). The grade of the reinforcement is indicated on the bars



**Figure 2.6** Some types of deformed bars and American standard bar marks.

by either the continuous-line system or the number system. In the first system, one longitudinal line is added to the bar, in addition to the main ribs, to indicate the high-strength grade of 60 ksi (420 N/mm<sup>2</sup>), according to ASTM specification A 617. If only the main ribs are shown on the bar, without any additional lines, the steel is of the ordinary grade according to ASTM A 615 for the structural grade ( $f_y = 40$  ksi, or 280 N/mm<sup>2</sup>). In the number system, the yield strength of the high-strength grades is marked clearly on every bar. For ordinary grades, no strength marks are indicated. The two types are shown in Fig. 2.6.

**Welded Fabrics and Mats.** Welded fabrics and mats consist of a series of longitudinal and transverse cold-drawn steel wires, generally at right angles and welded together at all points of intersection. Steel reinforcement may be built up into three-dimensional cages before being placed in the forms.

**Prestressed Concrete Wires and Strands.** Prestressed concrete wires and strands use special high-strength steel (see Chapter 20). High-tensile steel wires of diameters 0.192 in. (5 mm) and 0.276 in. (7 mm) are used to form the prestressing cables by winding six steel wires around a seventh wire of slightly larger diameter. The ultimate strength of prestressed strands is 250 or 270 ksi.

### 2.19.2 Grades and Strength

Different grades of steel are used in reinforced concrete. Limitations on the minimum yield strength, ultimate strength, are explained in ASTM specifications for reinforcing steel bars (Table 2.18). The properties and grades of metric reinforcing steel are shown in Tables 2.19 and 2.20.

ACI Code, Section 20.2.2.4 and 20.2.25 defines the types of nonprestressed bars and wires to be specified in two tables one is used for deformed bars while the other for plain reinforcement.

**Table 2.18** Grade of ASTM Reinforcing Steel Bars

Steel	Minimum Yield Strength $f_y$		Ultimate Strength $f_{su}$		
	ksi	MPa	ksi	MPa	
Billet steel					
Grade 40	40		276	70	483
60	60		414	90	621
75	75		518	100	690
80 [24]	80		550	—	—
Rail steel					
Grade 50	50		345	80	551
60	60		414	90	621
Deformed wire					
Reinforcing	75		518	85	586
Fabric	70		483	80	551
Cold-drawn wire					
Reinforcing	70		483	80	551
Fabric	65		448	75	518
Fabric	56		386	70	483

**Table 2.19** ASTM 615 M (Metric) for Reinforcing Steel Bars

Bar No.	Diameter (mm)	Area (mm <sup>2</sup> )	Weight (kg/m)
10 M	11.3	100	0.785
15 M	16.0	200	1.570
20 M	19.5	300	2.355
25 M	25.2	500	3.925
30 M	29.9	700	5.495
35 M	35.7	1000	7.850
45 M	43.7	1500	11.770
55 M	56.4	2500	19.600

**Table 2.20** ASTM Metric Specifications

ASTM	Bar Size No.		Grade
	MPa	ksi	
A615 M	10, 15, 20	300	43.5
Billet steel	10–55	400	58.0
	35, 45, 55	500	72.5
A616 M	10–35	350	50.75
Rail steel	10–35	400	58.0
A617 M	10–35	300	43.5
Axle steel	10–35	400	58.0
A706	10–55	400	58.0
Low alloy			

The code defines the type of structure and the recommended type of steel to be used. These are shown in Table 2.21 and Table 2.22.

### 2.19.3 Stress–Strain Curves

The most important factor affecting the mechanical properties and stress–strain curve of the steel is its chemical composition. The introduction of carbon and alloying additives in steel increases its strength but reduces its ductility. Commercial steel rarely contains more than 1.2% carbon; the proportion of carbon used in structural steels varies between 0.2 and 0.3%.

Two other properties are of interest in the design of reinforced concrete structures; the first is the modulus of elasticity,  $E_s$ . It has been shown that the modulus of elasticity is constant for all types of steel. The ACI Code has adopted a value of  $E_s = 29 \times 10^6$  psi ( $2.0 \times 10^5$  MPa).

The modulus of elasticity is the slope of the stress–strain curve in the elastic range up to the proportional limit;  $E_s = \text{stress}/\text{strain}$ . Second is the yield strength,  $f_y$ . Typical stress–strain curves for some steel bars are shown in Fig. 2.7. In high-tensile steel, a definite yield point may not show on the stress–strain curve. In this case, ultimate strength is reached gradually under an increase of stress (Fig. 2.7). The yield strength or proof stress is considered the stress that leaves a residual strain of 0.2% on the release of load, or a total strain of 0.5 to 0.6% under load.

Table 2.21 Nonprestressed Deformed Reinforcement

Usage	Application	Maximum value of $f_y$ or $f_{yt}$ permitted for design calculations, psi	Applicable ASTM Specification			
			Deformed Bars	Deformed Wires	Welded wire reinforcement	Welded deformed bar mats
Flexure, axial force, and shrinkage and temperature	Special seismic systems	60,000	Refer to 20.2.2.5	Not permitted	Not permitted	Not permitted
	Other	80,000	A615, A706, A955, A996	A1064, A1022	A1064, A1022	A184 <sup>a</sup>
Lateral support of longitudinal bars or concrete confinement	Special seismic systems	100,000	A615, A706, A955, A996, A1035	A1064, A1022	A1064 <sup>b</sup> , A1022 <sup>b</sup>	Not permitted
	Spirals	100,000	A615, A706, A955, A996, A1035	A1064, A1022	Not permitted	Not permitted
	Other	80,000	A615, A706, A955, A996	A1064, A1022	A1064, A1022	Not permitted
	Special Seismic Systems	60,000	A615, A706, A955, A996	A1064, A1022	A1064 <sup>b</sup> , A1022 <sup>b</sup>	Not permitted
Shear <sup>c</sup>	Spirals	60,000	A615, A706, A955, A996	A1064, A1022	Not permitted	Not permitted
	Shear friction	60,000	A615, A706, A955, A996	A1064, A1022	A1064, A1022	Not permitted
Stirrups, ties, hoops		60,000	A615, A706, A955, A996	A1064, A1022	A1064 and A1022 welded plain wire	Not permitted
		80,000	Not permitted	Not permitted	A1064 and A1022 welded deformed wire	Not permitted
Torsion	Longitudinal and transverse <sup>c</sup>	60,000	A615, A706, A955, A996	A1064, A1022	A1064, A1022	Not permitted

<sup>a</sup>Welded deformed bar mats shall be permitted to be assembled using A615 or A706 deformed bars.

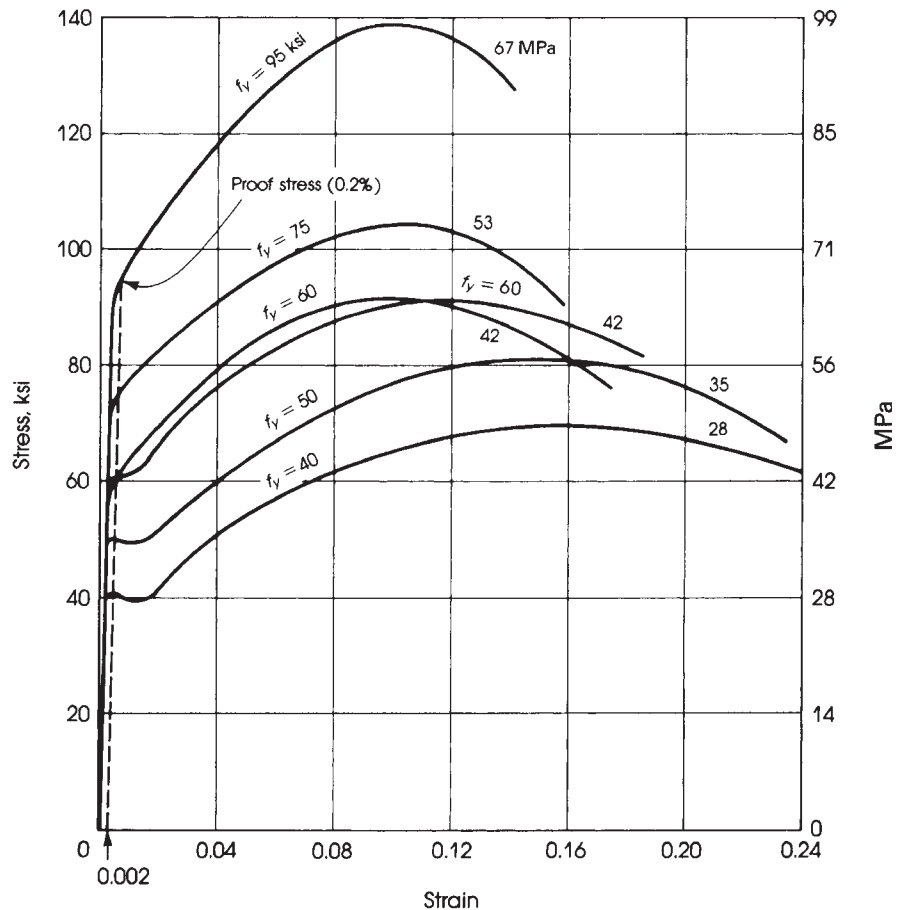
<sup>b</sup>ASTM A1064 and A1022 are not permitted in special seismic systems where the weld is required to resist stresses in response to confinement, lateral support of longitudinal bars, shear, or other actions.

<sup>c</sup>Nonprestressed bars and wires permitted for shear and transverse torsion also apply for special seismic.



**Table 2.22** Nonprestressed Plain Spiral Reinforcement

Usage	Application	Maximum Value Of $f_y$ or $f_{yt}$ Permitted for Design Calculations, psi	Applicable ASTM Specification	
			Plain Bars	Plain Wires
Lateral support of longitudinal bars or concrete confinement	Spirals in special seismic systems	100,000	A615, A706, A955, A1035	A1064, A1022
	Spirals	100,000	A615, A706, A955, A1035	A1064, A1022
Shear	Spirals	60,000	A615, A706, A955, A1035	A1064, A1022
Torsion in nonprestressed beams	Spirals	60,000	A615, A706, A955, A1035	A1064, A1022



**Figure 2.7** Typical stress–strain curves for some reinforcing steel bars of different grades. Note that 60-ksi steel may or may not show a definite yield point.

**SUMMARY****Section 2.1**

The main factors that affect the strength of concrete are the water–cement ratio, properties and proportions of materials, age of concrete, loading conditions, and shape of tested specimen.

$$f'_c(\text{cylinder}) = 0.85f'_c(\text{cube}) = 1.10f'_c(\text{prism})$$

**Sections 2.2–2.6**

1. The usual specimen used to determine the compressive strength of concrete at 28 days is a 6 × 12-in. (150 × 300-mm) cylinder. Compressive strength between 3000 and 6000 psi is usually specified for reinforced concrete structures. Maximum stress,  $f'_c$ , is reached at an estimated strain of 0.002, whereas rupture occurs at a strain of about 0.003.
2. Tensile strength of concrete is measured indirectly by a splitting test performed on a standard cylinder using formula  $f'_{sp} = 2P/\pi LD$ . Tensile strength of concrete is approximately  $0.1f'_c$ .
3. Flexural strength (modulus of rupture,  $f_r$ ) of concrete is calculated by testing a 6 × 6 × 28-in. plain concrete beam,  $f_r = 7.5\lambda\sqrt{f'_c}$  (psi), where  $\lambda$  is a modification factor related to unit weight of concrete.
4. Nominal shear stress is  $2\lambda\sqrt{f'_c}$  (psi).

**Sections 2.7–2.9**

The modulus of elasticity of concrete,  $E_c$  for unit weight  $w$  between 90 and 160 pcf, is  $E_c = 33w^{1.5}\sqrt{f'_c}$  (psi) =  $0.043w^{1.5}\sqrt{f'_c}$  MPa.

For normal-weight concrete,  $w = 145$  pcf.

$$E_c = 57,600\sqrt{f'_c} \quad \text{or} \quad E_c = 57,000\sqrt{f'_c} = 4700\sqrt{f'_c} \text{ MPa}$$

The shear modulus of concrete is  $G_c = E_c/2(1 + \mu) = 0.43 E_c$  for a Poisson ratio  $\mu = \frac{1}{6}$ . Poisson's ratio,  $\mu$ , varies between 0.15 and 0.20, with an average value of 0.18.

**Section 2.10**

Modular ratio is  $n = E_s/E_c = 500/\sqrt{f'_c}$ , where  $f'_c$  is in pounds per square inch.

**Section 2.11**

1. Values of shrinkage for normal concrete fall between  $200 \times 10^{-6}$  and  $700 \times 10^{-6}$ . An average value of  $300 \times 10^{-6}$  may be used.
2. The coefficient of expansion of concrete falls between  $4 \times 10^{-6}$  and  $7 \times 10^{-6}/^\circ\text{F}$ .

**Section 2.12–2.13**

The ultimate magnitude of creep varies between  $0.2 \times 10^{-6}$  and  $2 \times 10^{-6}$  per unit stress per unit length. An average value of  $1 \times 10^{-6}$  may be adopted in practical problems. Of the ultimate (20-year) creep, 18 to 35% occurs in 2 weeks, 30 to 70% occurs in 3 months, and 64 to 83% occurs in 1 year.

**Section 2.14**

The unit weight of normal concrete is 145 pcf for plain concrete and 150 pcf for reinforced concrete.

**Section 2.15**

Reinforced concrete is a much better fire-resistant material than steel. Concrete itself has a low thermal conductivity. An increase in concrete cover in structural members such as walls, columns, beams, and floor slabs will increase the fire resistance of these members.

**Sections 2.16–2.18**

1. High-performance concrete implies that concrete exhibits properties of strength, toughness, energy absorption, durability, stiffness, and ductility higher than normal concrete.
2. Concrete is made lighter than normal-weight concrete by inclusion of air in the concrete composition. Types of lightweight concrete are no-fines concrete, lightweight aggregate concrete, aerated concrete, and cellular concrete.
3. Fibrous concrete is made of concrete constituents and discrete reinforcing fibers such as steel, glass, and organic polymers.

**Section 2.19**

The grade of steel mainly used is grade 60 ( $f_y = 60$  ksi). The modulus of elasticity of steel is  $E_s = 29 \times 10^6$  psi ( $2 \times 10^5$  MPa).

**REFERENCES**

1. Portland Cement Association (PCA). *Design and Control of Concrete Mixtures*, 15th ed., PCA, Skokie, IL, 2011.
2. P. Bamforth, D. Chisholm, J. Gibbs, and T. Harrison. *Properties of Concrete for Use in Eurocode 2*. The Concrete Center, UK, 2008.
3. H. E. Davis, G. E. Troxell, and G. F. Hauck. *The Testing of Engineering Materials*. McGraw-Hill, New York, 1982.
4. Concrete Manual, 7th ed. U.S. Bureau of Reclamation. Washington, DC, 1963.
5. G. E. Troxell and H. E. Davis. *Composition and Properties of Concrete*. McGraw-Hill, New York, 1956.
6. A. M. Neville. *Properties of Concrete*, 4th ed. Longman, London, 2000.
7. G. Pickett. "Effect of Aggregate on Shrinkage of Concrete and Hypothesis Concerning Shrinkage." *ACI Journal* 52 (January 1956).
8. British Standard Institution (BSI). *B.S. Code of Practice for Structural Use of Concrete*. BS 8110. BSI, London, 1985.
9. Symposium on Shrinkage and Creep of Concrete. *ACI Journal* 53 (December 1957).
10. G. E. Troxell, J. M. Raphale, and R. E. Davis. "Long Time Creep and Shrinkage Tests of Plain and Reinforced Concrete." *ASTM Proceedings* 58 (1958), pp. 1101–1120.
11. "Fatigue of Concrete—Reviews of Research." *ACI Journal* 58 (1958).
12. ACI Committee 209. "Prediction of Creep, Shrinkage, and Temperature Effects in Concrete Structures (2092R-08)." In *ACI Manual of Concrete Practice, Part 1*. American Concrete Institute, Detroit, MI, 2011.

13. D. E. Branson and M. L. Christiason. "Time-Dependent Concrete Properties Related to Design—Strength and Elastic Properties, Creep, and Shrinkage." In *Designing for Effects of Creep, Shrinkage, and Temperature in Concrete Structures*. ACI SP-27. American Concrete Institute, Dearborn, MI, 1971, pp. 257–277.
14. Z. P. Bazant and S. Baweja. "Creep and Shrinkage Prediction Model for Analysis and Design of Concrete Structures: Model B3." In *The Adam Neville Symposium: Creep and Shrinkage—Structural Design Effects*. ACI SP-194. American Concrete Institute, Dearborn, MI, 2000, pp. 1–100.
15. N. J. Gardner. "Comparison of Prediction Provisions for Drying Shrinkage and Creep of Normal Strength." *Canadian Journal of Civil Engineers* 31 (2004): 767–775.
16. H. S. Muller and H. K. Hillisdorf. CEB Bulletin d'Information, No. 199, Evaluation of the Time Dependent Behavior of Concrete, Summary Report on the Work of General Task Group 9, September 1990.
17. H. S. Müllerer, C. H. Küttner, and V. Kvitsel. "Creep and Shrinkage Models of Normal and High-Performance Concrete—Concept for a Unified Code-Type Approach." *Revue Française de Genie Civil*, Special issue, Herms, Paris, 1999.
18. Special Activity Group 5, "Model Code 2010-Final Draft," *fib Bulletin* 1, no. 65, 2012.
19. American Association of State and Highway Transportation officials (AASHTO). *LRFD Bridge Design Specifications*, 7th ed. AASHTO, Washington, DC, 2014.
20. E. J. Callan. "Concrete for Radiation Shielding." *ACI Journal* 50 (1954).
21. J. Faber and F. Mead. *Reinforced Concrete*. Spon, London, 1967.
22. A. E. Newman and H. W. Reinhardt. "High Performance Fiber Reinforced Cement Composites." In *Proceedings*, vol. 2. University of Michigan, Ann Arbor, June 1995.
23. ACI Committee. *State-of-the-Art Report on Fiber Reinforced Concrete*. 544 Report. American Concrete Institute, Dearborn, MI, 1994.
24. D. P. Gustafson. "Raising the Grade," *Concrete International*, ACI, April 2010, pp. 59–62.

## PROBLEMS

- 2.1 Explain the modulus of elasticity of concrete in compression and the shear modulus.
- 2.2 Determine the modulus of elasticity of concrete by the ACI formula for a concrete cylinder that has a unit weight of 120 pcf (1920 kg/m<sup>3</sup>) and a compressive strength of 3000 psi (21 MPa).
- 2.3 Estimate the modulus of elasticity and the shear modulus of a concrete specimen with a dry density of 150 pcf (2400 kg/m<sup>3</sup>) and compressive strength of 4500 psi (31 MPa) using Poisson's ratio,  $\mu = 0.18$ .
- 2.4 What is meant by the modular ratio and Poisson's ratio? Give approximate values for concrete.
- 2.5 What factors influence the shrinkage of concrete?
- 2.6 What factors influence the creep of concrete?
- 2.7 What are the types and grades of the steel reinforcement used in reinforced concrete?
- 2.8 On the stress–strain diagram of a steel bar, show and explain the following: proportional limit, yield stress, ultimate stress, yield strain, and modulus of elasticity.
- 2.9 Calculate the modulus of elasticity of concrete,  $E_c$ , for the following types of concrete:

$$E_c = 33w^{1.5}\sqrt{f'_c} \text{ (ft)}$$

$$= 0.043w^{1.5}\sqrt{f'_c} \text{ (SI)}$$

Density	Strength $f'_c$
160 pcf	5000 psi
145 pcf	4000 psi
125 pcf	2500 psi
2400 kg/m <sup>3</sup>	35 MPa
2300 kg/m <sup>3</sup>	30 MPa
2100 kg/m <sup>3</sup>	25 MPa

- 2.10** Determine the modular ratio,  $n$ , and the modulus of rupture for each case of Problem 2.9. Tabulate your results.

$$f_r = 7.5\lambda\sqrt{f'_c} \text{ (psi)} \quad f_r = 0.62\lambda\sqrt{f'_c} \text{ (MPa)}$$

- 2.11** A  $6 \times 12$ -in. concrete cylinder was tested to failure. The following loads and strains were recorded:

Load, kips	Strain $\times 10^{-4}$	Load, kips	Strain $\times 10^{-4}$
0.0	0.0	72	10.0
12	1.2	84	13.6
24	2.0	96	18.0
36	3.2	108	30.0
48	5.2	95	39.0
60	7.2	82	42.0

- Draw the stress–strain diagram of concrete and determine the maximum stress and corresponding strain.
- Determine the initial modulus and secant modulus.
- Calculate the modulus of elasticity of concrete using the ACI formula for normal-weight concrete and compare results.

$$E_c = 57,000\sqrt{f'_c} \text{ psi}$$

$$= 4730\sqrt{f'_c} \text{ MPa}$$

- 2.12** Calculate the shrinkage strain, creep compliance, and creep coefficient using the ACI 209R-92 model for a  $6 \times 12$ -in. steam-cured concrete cylinder made with type III portland cement. Given:

H	90	%
$h_e = 2V/S$	6	in.
$f_{cm28}$	4021	psi
$w$	345	lb/yd <sup>3</sup>
$w/c$	0.4	
$a/c$	3.25	
$t$	400	days
$t_0$	28	days
$t_c$	1	days
$\gamma$	146	lb/ft <sup>3</sup>

- Calculate the shrinkage strain, creep compliance, and creep coefficient for problem 2.12 using the GL 2000 Model.
- Calculate the shrinkage strain, creep compliance, and creep coefficient for problem 2.12 using the fib MC 2010 Model.
- A concrete specimen has the following properties: Relative Humidity = 50%;  $h_e = 2V/S = 35$  mm;  $f_{cm28} = 33.9$  MPa; cement content (c) = 350 kg/m<sup>3</sup>,  $w/c = 0.49$ ,  $a/c = 4.814$ ,  $t_0 = 7$  days,  $\gamma = 2296.74$  kg/m<sup>3</sup>. The specimen is made with Type I portland cement and was moist-cured.
  - Calculate the creep compliance utilizing the ACI 209R-92 and fib MC 2010 models at ages of: 14, 90, 365, 2190 and 3650 days.
  - Create a plot showing the ACI 209R-92 and fib MC 2010 creep compliance predictions versus loading duration up to 3650 days.
  - Comment on the trend of both models.

- 2.16** A concrete specimen has the following properties: Relative humidity = 50%;  $h_e = 2V/S = 51$  mm;  $f_{cm28} = 16.5$  MPa; cement content ( $c$ ) =  $320 \text{ kg/m}^3$ ,  $w/c = 0.59$ ,  $a/c = 5.669$ ,  $t_c = 28$  days,  $\gamma = 2296.74 \text{ kg/m}^3$ . The specimen is made with Type I portland cement and was moist-cured.
- Calculate the shrinkage strain using the B3 and the GL 2000 models at ages of: 56, 90, 365, 2190, and 3650 days.
  - Create a plot showing the B3 and GL 2000 shrinkage strain predictions versus age up to 3650 days.

# CHAPTER 3

## FLEXURAL ANALYSIS OF REINFORCED CONCRETE BEAMS



Apartment building, Fort Lauderdale, Florida.

### 3.1 INTRODUCTION

The analysis and design of a structural member may be regarded as the process of selecting the proper materials and determining the member dimensions such that the design strength is equal or greater than the required strength. The required strength is determined by multiplying the actual applied loads, the dead load, the assumed live load, and other loads, such as wind, seismic, earth pressure, fluid pressure, snow, and rain loads, by load factors. These loads develop external forces such as bending moments, shear, torsion, or axial forces, depending on how these loads are applied to the structure.

In proportioning reinforced concrete structural members, three main items can be investigated:

1. The safety of the structure, which is maintained by providing adequate internal design strength.
2. Deflection of the structural member under service loads. The maximum value of deflection must be limited and is usually specified as a factor of the span, to preserve the appearance of the structure.
3. Control of cracking conditions under service loads. Visible cracks spoil the appearance of the structure and also permit humidity to penetrate the concrete, causing corrosion of steel and consequently weakening the reinforced concrete member. The ACI Code implicitly limits crack widths to 0.016 in. (0.40 mm) for interior members and 0.013 in. (0.33 mm) for exterior members. Control of cracking is achieved by adopting and limiting the spacing of the tension bars (see Chapter 6).

It is worth mentioning that the strength design approach was first permitted in the United States in 1956 and in Britain in 1957. The latest ACI Code emphasizes the strength concept based on specified strain limits on steel and concrete that develop tension-controlled, compression-controlled, or transition conditions.

### 3.2 ASSUMPTIONS

Reinforced concrete sections are heterogeneous (nonhomogeneous), because they are made of two different materials, concrete and steel. Therefore, proportioning structural members by strength design approach is based on the following assumptions:

1. Strain in concrete is the same as in reinforcing bars at the same level, provided that the bond between the steel and concrete is adequate.
2. Strain in concrete is linearly proportional to the distance from the neutral axis.
3. The modulus of elasticity of all grades of steel is taken as  $E_s = 29 \times 10^6 \text{ lb/in.}^2$  (200,000 MPa or  $\text{N/mm}^2$ ). The stress in the elastic range is equal to the strain multiplied by  $E_s$ .
4. Plane cross sections continue to be plane after bending.
5. Tensile strength of concrete is neglected because (a) concrete's tensile strength is about 10% of its compressive strength, (b) cracked concrete is assumed to be not effective, and (c) before cracking, the entire concrete section is effective in resisting the external moment.
6. The method of elastic analysis, assuming an ideal behavior at all levels of stress, is not valid. At high stresses, nonelastic behavior is assumed, which is in close agreement with the actual behavior of concrete and steel.
7. At failure the maximum strain at the extreme compression fibers is assumed equal to 0.003 by the ACI Code provision.
8. For design strength, the shape of the compressive concrete stress distribution may be assumed to be rectangular, parabolic, or trapezoidal. In this text, a rectangular shape will be assumed (ACI Code, Section 22.2).

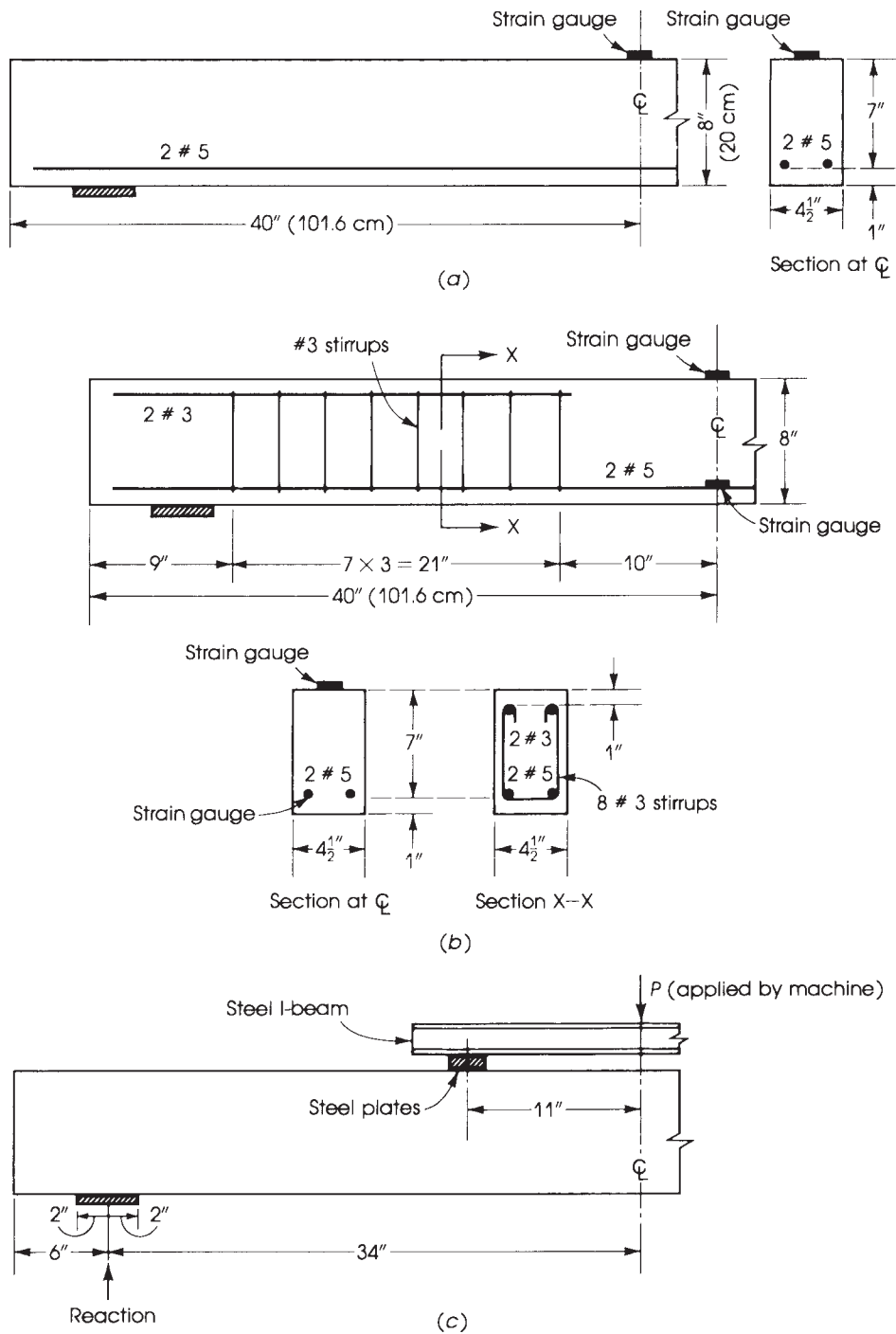
### 3.3 BEHAVIOR OF SIMPLY SUPPORTED REINFORCED CONCRETE BEAM LOADED TO FAILURE

Concrete being weakest in tension, a concrete beam under an assumed working load will definitely crack at the tension side, and the beam will collapse if tensile reinforcement is not provided. Concrete cracks occur at a loading stage when its maximum tensile stress reaches the modulus of rupture of concrete. Therefore, steel bars are used to increase the moment capacity of the beam; the steel bars resist the tensile force, and the concrete resists the compressive force.

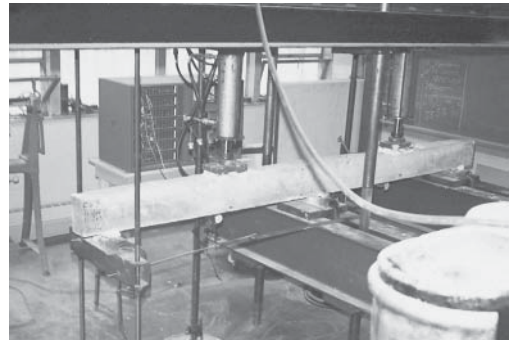
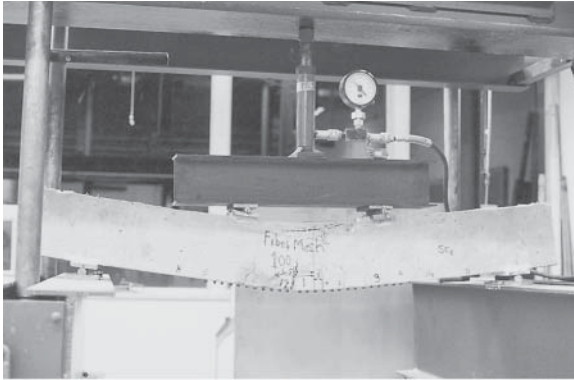
To study the behavior of a reinforced concrete beam under increasing load, let us examine how two beams were tested to failure. Details of the beams are shown in Fig. 3.1. Both beams had a section of  $4.5 \times 8 \text{ in.}$  ( $110 \times 200 \text{ mm}$ ), reinforced only on the tension side by two no. 5 bars. They were made of the same concrete mix. Beam 1 had no stirrups, whereas beam 2 was provided with no. 3 stirrups spaced at 3 in. The loading system and testing procedure were the same for both beams. To determine the compressive strength of the concrete and its modulus of elasticity,  $E_c$ , a standard concrete cylinder was tested, and strain was measured at different load increments. The following observations were noted at different distinguishable stages of loading.

**Stage 1.** At zero external load, each beam carried its own weight in addition to that of the loading system, which consisted of an I-beam and some plates. Both beams behaved similarly at this stage. At any section, the entire concrete section, in addition to the steel reinforcement, resisted the bending moment and shearing forces. Maximum stress occurred at the section of maximum bending moment—that is, at midspan. Maximum tension stress at the bottom fibers was much less than the modulus of rupture of concrete. Compressive stress at the top fibers was much less than the ultimate concrete compressive stress,  $f'_c$ . No cracks were observed at this stage.

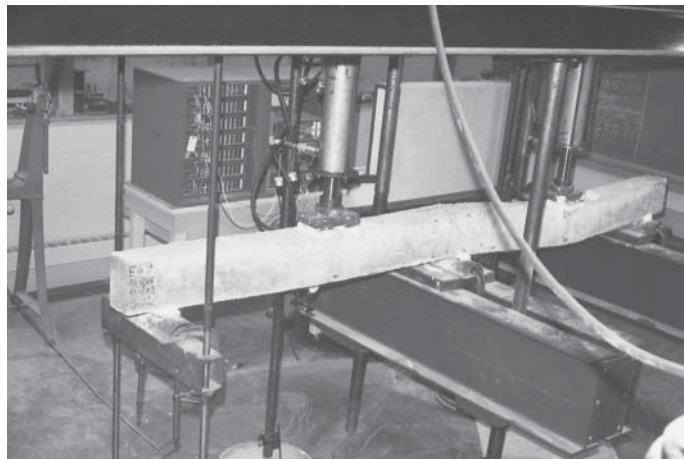




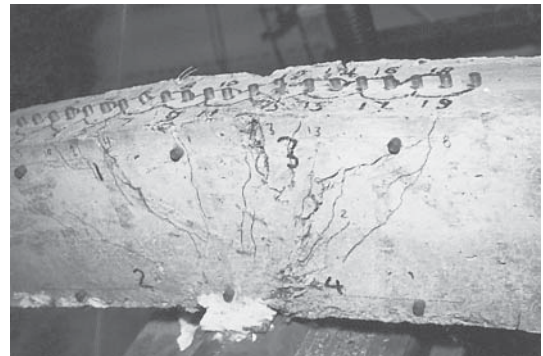
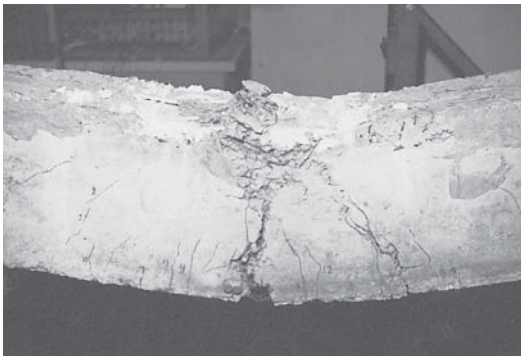
**Figure 3.1** Details of tested beams: (a) beam 1, (b) beam 2, and (c) loading system. All beams are symmetrical about the centerline.



Test on a simply supported beam and a two-span continuous beam loaded to failure.



Two-span continuous reinforced concrete beam loaded to failure.



Failure conditions at the positive- and negative-moment sections in a continuous reinforced concrete beam.

**Stage 2.** This stage was reached when the external load,  $P$ , was increased from 0 to  $P_1$ , which produced tensile stresses at the bottom fibers equal to the modulus of rupture of concrete. At this stage the entire concrete section was effective, with the steel bars at the tension side sustaining a strain equal to that of the surrounding concrete.

Stress in the steel bars was equal to the stress in the adjacent concrete multiplied by the modular ratio,  $n$ , is the ratio of the modulus of elasticity of steel to that of concrete. The compressive stress of concrete at the top fibers was still very small compared with the compressive strength,  $f'_c$ . The behavior of beams was elastic within this stage of loading.

**Stage 3.** When the load was increased beyond  $P_1$ , tensile stresses in concrete at the tension zone increased until they were greater than the modulus of rupture,  $f_r$ , and cracks developed. The neutral axis shifted upward, and cracks extended close to the level of the shifted neutral axis. Concrete in the tension zone lost its tensile strength, and the steel bars started to work effectively and to resist the entire tensile force. Between cracks, the concrete bottom fibers had tensile stresses, but they were of negligible value. It can be assumed that concrete below the neutral axis did not participate in resisting external moments.

In general, the development of cracks and the spacing and maximum width of cracks depend on many factors, such as the level of stress in the steel bars, distribution of steel bars in the section, concrete cover, and grade of steel used.

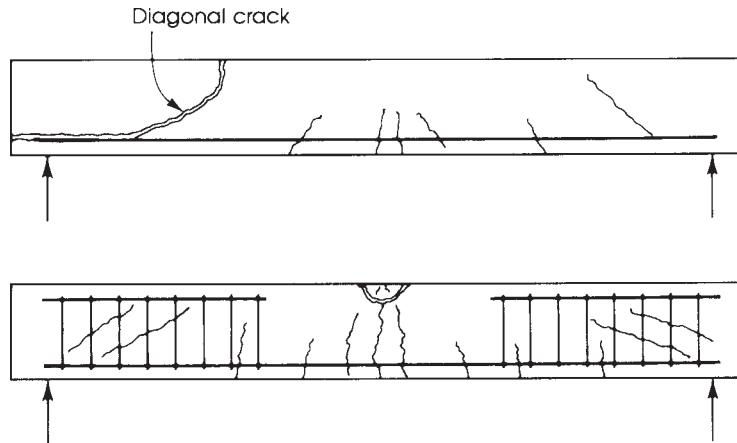
At this stage, the deflection of the beams increased clearly because the moment of inertia of the cracked section was less than that of the uncracked section. Cracks started about the midspan of the beam, but other parts along the length of the beam did not crack. When load was again increased, new cracks developed, extending toward the supports. The spacing of these cracks depends on the concrete cover and the level of steel stress. The width of cracks also increased. One or two of the central cracks were most affected by the load, and their crack widths increased appreciably, whereas the other crack widths increased much less. It is more important to investigate those wide cracks than to consider the larger number of small cracks.

If the load were released within this stage of loading, it would be observed that permanent fine cracks of no significant magnitude were left. On reloading, cracks would open quickly because the tensile strength of concrete had already been lost. Therefore, it can be stated that the second stage, once passed, does not happen again in the life of the beam. When cracks develop under working loads, the resistance of the entire concrete section and gross moment of inertia are no longer valid.

At high compressive stresses, the strain of the concrete increased rapidly, and the stress of concrete at any strain level was estimated from a stress–strain graph obtained by testing a standard cylinder to failure for the same concrete. As for the steel, the stresses were still below the yield stress, and the stress at any level of strain was obtained by multiplying the strain of steel,  $\epsilon_s$ , by the modulus of elasticity of steel,  $E_s$ .

**Stage 4.** In beam 1, at a load value of 9500 lb (42.75 kN), shear stress at a distance of about the depth of the beam from the support increased and caused diagonal cracks at approximately 45° from horizontal in the direction of principal stresses resulting from the combined action of bending moment and shearing force. The diagonal crack extended downward to the level of the steel bars and then extended horizontally at that level toward the support. When the crack, which had been widening gradually, reached the end of the beam, a concrete piece broke off and failure occurred suddenly (Fig. 3.2). The failure load was 13,600 lb (61.2 kN). Stresses in concrete and steel at the midspan section did not reach their failure stresses. (The shear behavior of beams is discussed in Chapter 8.)

In beam 2, at a load of 11,000 lb (49.5 kN), a diagonal crack developed similar to that of beam 1; then other parallel diagonal cracks appeared, and the stirrups started to take an effective



**Figure 3.2** Shape of beam 1 at shear failure (*top*) and beam 2 at bending moment failure (*bottom*).

part in resisting the principal stresses. Cracks did not extend along the horizontal main steel bars, as in beam 1. On increasing the load, diagonal cracks on the other end of the beam developed at a load of 13,250 lb (59.6 kN). Failure did not occur at this stage because of the presence of stirrups.

**Stage 5.** When the load on beam 2 was further increased, strains increased rapidly until the maximum carrying capacity of the beam was reached at ultimate load,  $P_u = 16,200$  lb (72.9 kN).

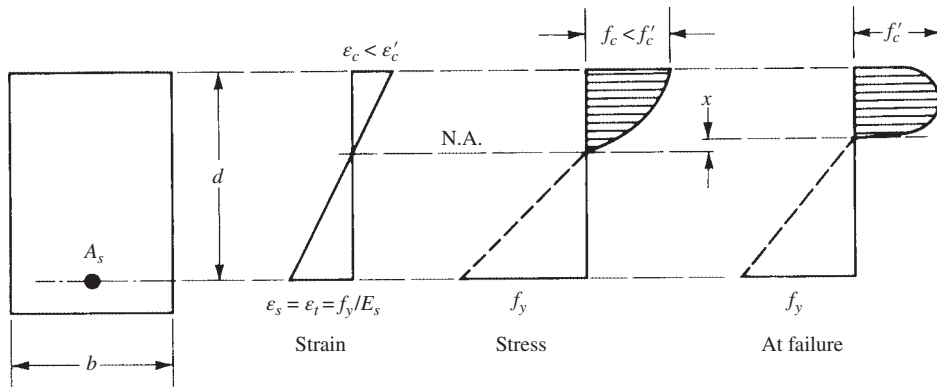
In beam 2, the amount of steel reinforcement used was relatively small. When reached, the yield strain can be considered equal to yield stress divided by the modulus of elasticity of steel,  $\epsilon_y = f_y/E_s$ ; the strain in the concrete,  $\epsilon_c$ , was less than the strain at maximum compressive stress,  $f'_c$ . The steel bars yielded, and the strain in steel increased to about 12 times that of the yield strain without increase in load. Cracks widened sharply, deflection of the beam increased greatly, and the compressive strain on the concrete increased. After another very small increase of load, steel strain hardening occurred, and concrete reached its maximum strain,  $\epsilon'_c$ , and it started to crush under load; then the beam collapsed. Figure 3.2 shows the failure shapes of the two beams.

## 3.4 TYPES OF FLEXURAL FAILURE AND STRAIN LIMITS

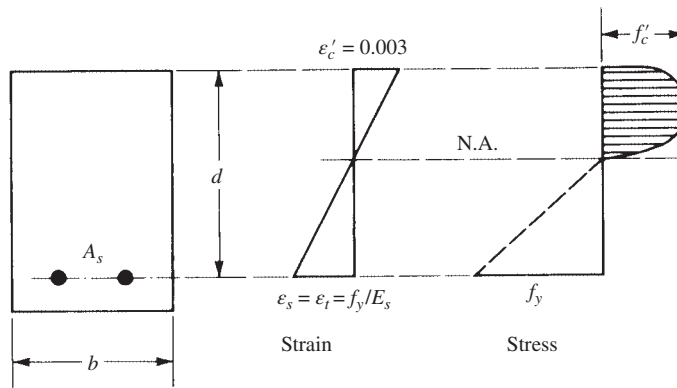
### 3.4.1 Flexural Failure

Three types of flexural failure of a structural member can be expected depending on the percentage of steel used in the section.

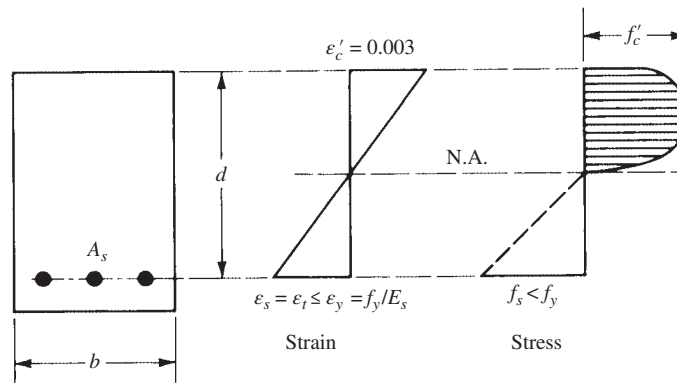
1. Steel may reach its yield strength before the concrete reaches its maximum strength, Fig. 3.3a. In this case, the failure is due to the yielding of steel reaching a high strain equal to or greater than 0.005. The section contains a relatively small amount of steel and is called a tension-controlled section.
2. Steel may reach its yield strength at the same time as concrete reaches its ultimate strength, Fig. 3.3b. The section is called a balanced section.
3. Concrete may fail before the yield of steel, Fig. 3.3c, due to the presence of a high percentage of steel in the section. In this case, the concrete strength and its maximum strain of 0.003 are reached, but the steel stress is less than the yield strength, that is,  $f_s$  is less than  $f_y$ . The strain in the steel is equal to or less than 0.002. This section is called a compression-controlled section.



(a)



(b)



(c)

**Figure 3.3** Stress and strain diagrams for (a) tension-controlled, (b) balanced, and (c) compression-controlled sections.

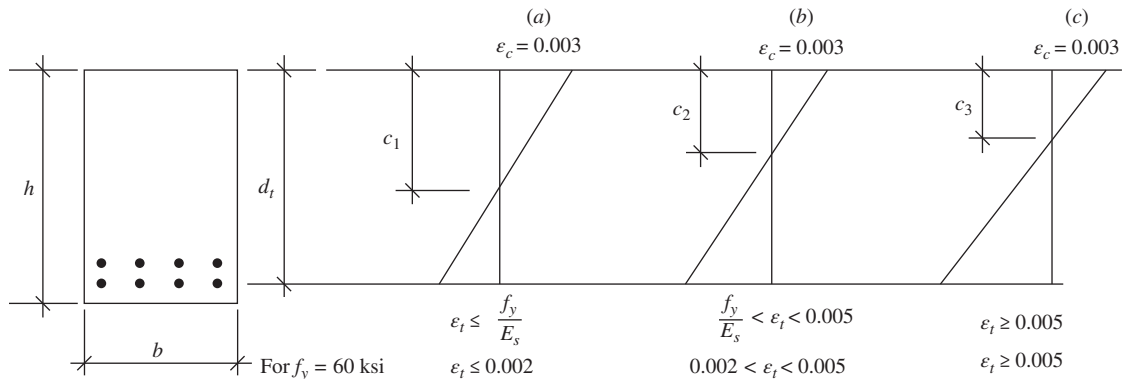
It can be assumed that concrete fails in compression when the concrete strain reaches 0.003. A range of 0.0025 to 0.004 has been obtained from tests and the ACI Code, Section 22.2.2.1, assumes a strain of 0.003.

In beams designed as tension-controlled sections, steel yields before the crushing of concrete. Cracks widen extensively, giving warning before the concrete crushes and the structure collapses. The ACI Code adopts this type of design. In beams designed as balanced or compression-controlled sections, the concrete fails suddenly, and the beam collapses immediately without warning. The ACI Code does not allow this type of design.

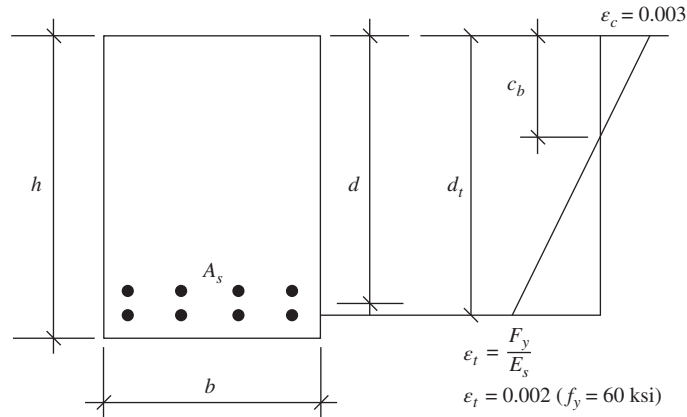
### 3.4.2 Strain Limits for Tension and Tension-Controlled Sections

The design provisions for both reinforced and prestressed concrete members are based on the concept of tension or compression-controlled sections, ACI Code, Section 21.2. Both are defined in terms of net tensile strain (NTS), ( $\epsilon_t$ , in the extreme tension steel at nominal strength, exclusive of prestress strain. Moreover, two other conditions may develop: (1) the balanced strain condition and (2) the transition region condition. These four conditions are defined as follows:

1. Compression-controlled sections are those sections in which the net tensile strain, NTS, in the extreme tension steel at nominal strength is equal to or less than the compression-controlled strain limit at the time when concrete in compression reaches its assumed strain limit of 0.003, ( $\epsilon_c = 0.003$ ). For grade 60 steel, ( $f_y = 60$  ksi), the compression-controlled strain limit may be taken as a net strain of 0.002, Fig. 3.4a. This case occurs mainly in columns subjected to axial forces and moments.
2. Tension-controlled sections are those sections in which the NTS,  $\epsilon_t$ , is equal to or greater than 0.005 just as the concrete in the compression reaches its assumed strain limit of 0.003, Fig. 3.4c.
3. Sections in which the NTS in the extreme tension steel lies between the compression-controlled strain limit (0.002 for  $f_y = 60$  ksi) and the tension-controlled strain limit of 0.005 constitute the transition region, Fig. 3.4b.
4. The balanced strain condition develops in the section when the tension steel, with the first yield, reaches a strain corresponding to its yield strength,  $f_y$  or  $\epsilon_s = f_y/E_s$ , just as the maximum strain in concrete at the extreme compression fibers reaches 0.003, Fig. 3.5.



**Figure 3.4** Strain limit distribution,  $c_1 > c_2 > c_3$ : (a) compression-controlled section, (b) transition region, and (c) tension-controlled section.



**Figure 3.5** Balanced strain section (occurs at first yield or at distance  $d_t$ ).

**Table 3.1** Strain Limits of Figure 3.4

Section Condition	Concrete Strain	Steel Strain	Notes ( $f_y = 60$ ksi)
Compression controlled	0.003	$\epsilon_t \leq f_y/E_s$	$\epsilon_t \leq 0.002$
Tension controlled	0.003	$\epsilon_t \geq 0.005$	$\epsilon_t \geq 0.005$
Transition region	0.003	$f_y/E_s < \epsilon_t < 0.005$	$0.002 < \epsilon_t < 0.005$
Balanced strain	0.003	$\epsilon_s = f_y/E_s$	$\epsilon_s = 0.002$
Transition region (flexure)	0.003	$0.004 \leq \epsilon_t < 0.005$	$0.004 \leq \epsilon_t < 0.005$

In addition to the above four conditions, Section 9.3.3.1 of the ACI Code indicates that the net tensile strain,  $\epsilon_t$ , at nominal strength, within the transition region, shall not be less than 0.004 for reinforced concrete flexural members without or with an axial load less than  $0.10 f'_c A_g$ , where  $A_g$  = gross area of the concrete section.

Note that  $d_t$  in Fig. 3.4, is the distance from the extreme concrete compression fiber to the extreme tension steel, while the effective depth,  $d$ , equals the distance from the extreme concrete compression fiber to the centroid of the tension reinforcement, Fig. 3.5. These cases are summarized in Table 3.1.

### 3.5 LOAD FACTORS

The types of loads and the safety provisions were explained earlier in Sections 1.7 and 1.8.

For the design of structural members, the factored design load is obtained by multiplying the dead load by a load factor and the specified live load by another load factor. The magnitude of the load factor must be adequate to limit the probability of sudden failure and to permit an economical structural design. The choice of a proper load factor or, in general, a proper factor of safety depends mainly on the importance of the structure (whether a courthouse or a warehouse), the degree of warning needed prior to collapse, the importance of each structural member (whether a beam or column), the expectation of overload, the accuracy of artisanry, and the accuracy of calculations.

Based on historical studies of various structures, experience, and the principles of probability, the ACI Code adopts a load factor of 1.2 for dead loads and 1.6 for live loads. The dead-load factor

is smaller because the dead load can be computed with a greater degree of certainty than the live load. Moreover, the choice of factors reflects the degree of the economical design as well as the degree of safety and serviceability of the structure. It is also based on the fact that the performance of the structure under actual loads must be satisfactorily within specific limits.

If the required strength is denoted by  $U$  (ACI Code, Section 5.3.1), and those due to wind and seismic forces are  $W$  and  $E$ , respectively, according to the ACI and ASCE 7-10 Codes, the required strength,  $U$ , shall be the most critical of the following factors:

1. In the case of dead, live, and wind loads,

$$U = 1.4D \quad (3.1a)$$

$$U = 1.2D + 1.6L \quad (3.1b)$$

$$U = 1.2D + 1.0L + 1.0W \quad (3.1c)$$

$$U = 0.9D + 1.0W \quad (3.1d)$$

$$U = 1.2D + (1.0L \text{ or } 0.5W) \quad (3.1e)$$

2. In the case of dead, live, and seismic (earthquake) forces,  $E$ ,

$$U = 1.2D + 1.0L + 1.0E \quad (3.2a)$$

$$U = 0.9D + 1.0E \quad (3.2b)$$

3. For load combination due to roof live load,  $L_r$ , rain load,  $R$ , snow load,  $S$ , in addition to dead, live, wind, and earthquake load,

$$U = 1.2D + 1.6L + 0.5(L_r \text{ or } S \text{ or } R) \quad (3.3a)$$

$$U = 1.2D + 1.6(L_r \text{ or } S \text{ or } R) + (1.0L \text{ or } 0.5W) \quad (3.3b)$$

$$U = 1.2D + 1.0W + 1.0L + 0.5(L_r \text{ or } S \text{ or } R) \quad (3.3c)$$

$$U = 1.2D + 1.0E + 1.0L + 0.2S \quad (3.3d)$$

4. Where fluid load  $F$  is present, it shall be included as follows:

$$U = 1.4(D + F) \quad (3.4a)$$

$$U = 1.2D + 1.2F + 1.6L + 0.5(L_r \text{ or } S \text{ or } R) \quad (3.4b)$$

$$U = 1.2D + 1.2F + (L + 0.5W) + 1.6(L_r \text{ or } S \text{ or } R) \quad (3.4c)$$

$$U = 1.2D + 1.2F + 1.0W + L + 0.5(L_r \text{ or } S \text{ or } R) \quad (3.4d)$$

$$U = 1.2D + 1.2F + 1.0E + L + 0.2S \quad (3.4e)$$

$$U = 0.9(D + F) + 1.0E \quad (3.4f)$$

5. When the load  $H$  (load due to lateral earth pressure, groundwater pressure, or pressure of bulk material) is present, it shall be included as follows:

- a. Include  $H$  with load factor 1.6, where effect of  $H$  adds to the primary variable load effect.

- b. Include  $H$  with load factor 0.90, where effect of  $H$  resist to the primary variable load effect

$$U = \text{primary permanent loads} + 1.6H \quad (3.5a)$$

$$U = \text{primary permanent loads} - 0.9H \quad (3.5b)$$



It is to noted that

1. The load factor  $L$  in Eqs. 3.1c, 3.1e, 3.2a, 3.3b, 3.3c, and 3.3d shall be permitted to be reduced to  $0.5L$ , except for garages, areas occupied as places of public assembly, and all areas where the live load  $L$  is greater than 100 pounds per square foot (psf).
2. Where  $W$  is based on service wind loads,  $1.6W$  shall be used in place of  $1.0W$  in Eqs. 3.1c, 3.1d, and 3.3c and  $0.8W$  shall be used in place of  $0.5W$  in Eqs. 3.1e and Eqs. 3.3b.
3. If the service level of the seismic load  $E$  is used,  $1.4E$  shall be used in place of  $1.0E$  in Eqs. 3.2a and b and 3.3d.
4. In a flood zone area, the flood load or load combinations of ASCE shall be used.
5. Impact effects shall be included with the live load  $L$ .

The ACI Code does not specify a value for impact, but AASHTO specifications give a simple factor for impact,  $I$ , as a percentage of the live load  $L$  as follows:

$$I = \frac{50}{125 + S} \leq 30\% \quad (3.6)$$

where  $I$  is the percentage of impact,  $S$  is the part of the span loaded, and live load including impact is  $L(1 + I)$ .

When a better estimation is known from experiments or experience, the adjusted value shall be used.

### 3.6 STRENGTH REDUCTION FACTOR $\phi$

The nominal strength of a section, say  $M_n$ , for flexural members, calculated in accordance with the requirements of the ACI Code provisions must be multiplied by the strength reduction factor,  $\phi$ , which is always less than 1. The strength reduction factor has several purposes:

1. To allow for the probability of understrength sections due to variations in dimensions, material properties, and inaccuracies in the design equations.
2. To reflect the importance of the member in the structure.
3. To reflect the degree of ductility and required reliability under the applied loads.

The ACI Code, Table 21.2.1, specifies the following values to be used:

For tension-controlled sections	$\phi = 0.90$
For compression-controlled sections	
a. with spiral reinforcement	$\phi = 0.75$
b. other reinforced members	$\phi = 0.65$
For plain concrete	$\phi = 0.60$
For shear and torsion	$\phi = 0.75$
For bearing on concrete	$\phi = 0.65$
For strut and tie models	$\phi = 0.75$

A higher  $\phi$  factor is used for tension-controlled sections than for compression-controlled sections, because the latter sections have less ductility and they are more sensitive to variations in concrete strength. Also, spirally reinforced compression members have a  $\phi$  value of 0.75 compared to 0.65 for tied compression members; this variation reflects the greater ductility behavior of spirally reinforced concrete members under the applied loads. In the ACI Code provisions, the  $\phi$  factor is

based on the behavior of the cross section at nominal strength,  $(P_n, M_n)$ , defined in terms of the NTS,  $\epsilon_t$ , in the extreme tensile strains, as given in Table 3.1. For tension-controlled members,  $\phi = 0.9$ . For compression-controlled members,  $\phi = 0.75$  (with spiral reinforcement) and  $\phi = 0.65$  for other members.

For the transition region,  $\phi$  may be determined by linear interpolation between 0.65 (or 0.75) and 0.9. Figure 3.6a shows the variation of  $\phi$  for grade 60 steel. The linear equations are as follows:

$$\phi = \begin{cases} 0.75 + (\epsilon_t - 0.002)(50) & \text{(for spiral members)} & (3.7) \\ 0.65 + (\epsilon_t - 0.002)\left(\frac{250}{3}\right) & \text{(for other members)} & (3.8) \end{cases}$$

Alternatively,  $\phi$  may be determined in the transition region, as a function of  $(c/d_t)$  for grade 60 steel as follows:

$$\phi = \begin{cases} 0.75 + 0.15 \left[ \frac{1}{c/d_t} - \frac{5}{3} \right] & \text{(for spiral members)} & (3.9) \\ 0.65 + 0.25 \left[ \frac{1}{c/d_t} - \frac{5}{3} \right] & \text{(for other members)} & (3.10) \end{cases}$$

where  $c$  is the depth of the neutral axis at nominal strength ( $c_2$  in Fig. 3.4). At the limit strain of 0.002 for grade 60 steel and from the triangles of Fig. 3.4a,  $c/d_t = 0.003/(0.002+0.003) = 0.6$ . Similarly, at a strain,  $\epsilon_t = 0.005$ ,  $c/d_t = 0.003/(0.005+0.003) = 0.375$ . Both values are shown in Fig. 3.6.

For reinforced concrete flexural members, the NTS,  $\epsilon_t$ , should be equal to or greater than 0.004 (ACI Code, Section 22.2.2). In this case,

$$\phi = 0.65 + (\epsilon_t - 0.002)\left(\frac{250}{3}\right) = 0.82 \quad (3.11)$$

Figure 3.6b shows the range of  $\phi$  for flexural members. For grade 60 steel, the range varies between 0.9 for  $\epsilon_t \geq 0.005$  and 0.82 for  $\epsilon_t = 0.004$ . Other values of  $\phi$  can be obtained from Eq. 3.11 or by interpolation.

### 3.7 SIGNIFICANCE OF ANALYSIS AND DESIGN EXPRESSIONS

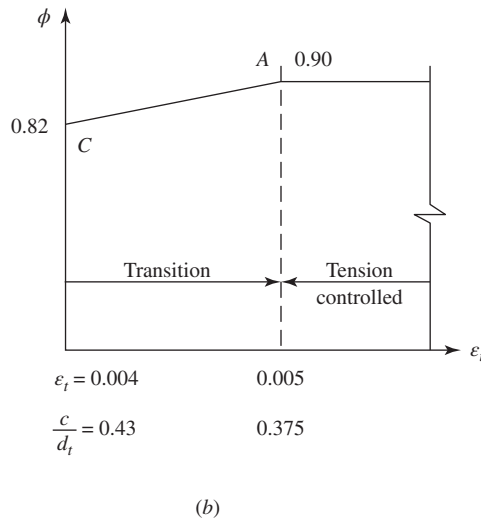
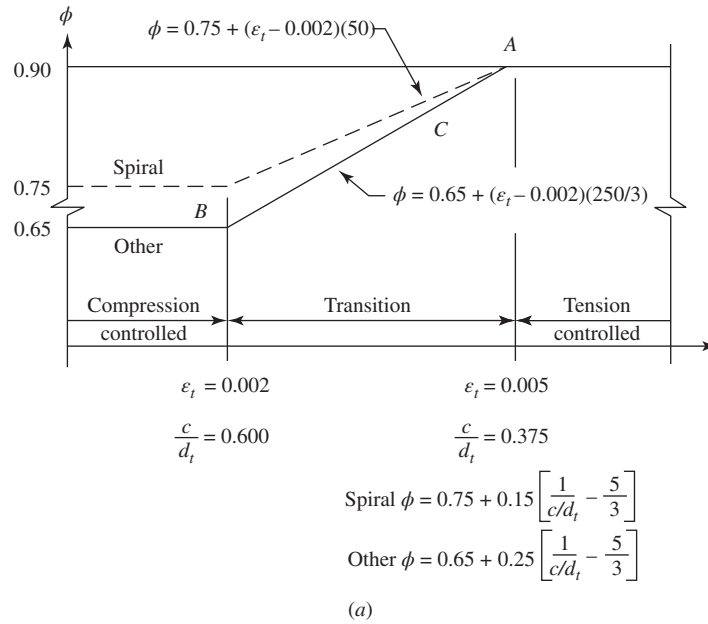
Two approaches for the investigations of a reinforced concrete member will be used in this book:

*Analysis of a section* implies that the dimensions and steel used in the section (in addition to concrete strength and steel yield strength) are given, and it is required to calculate the internal design moment capacity of the section so that it can be compared with the applied external required moment.

*Design of a section* implies that the external required moment is known from structural analysis, and it is required to compute the dimensions of an adequate concrete section and the amount of steel reinforcement. Concrete strength and yield strength of steel used are given.

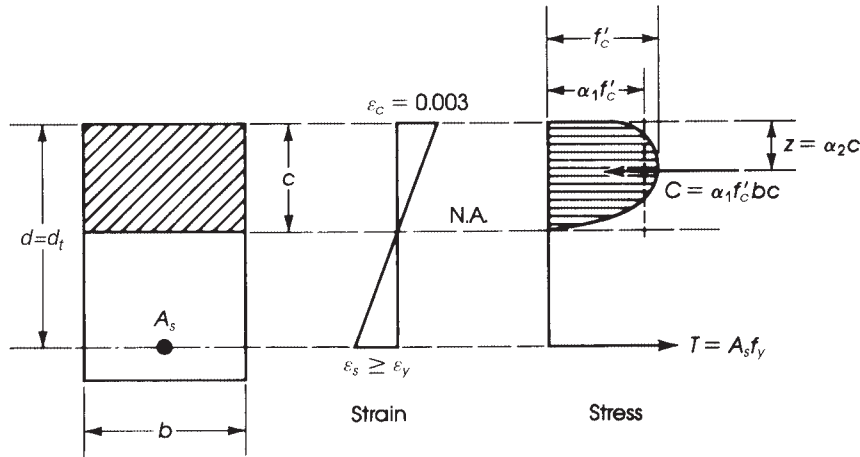
### 3.8 EQUIVALENT COMPRESSIVE STRESS DISTRIBUTION

The distribution of compressive concrete stresses at failure may be assumed to be a rectangle, trapezoid, parabola, or any other shape that is in good agreement with test results.



**Figure 3.6** (a) Variation of  $\phi$ , with the net tensile strain for grade 60 steel and for pre-stressed steel [1]; (b) variation of  $\phi$  and strain limit in flexural member with  $f_y = 60$  ksi.

When a beam is about to fail, the steel will yield first if the section is underreinforced, and in this case the steel is equal to the yield stress. If the section is overreinforced, concrete crushes first and the strain is assumed to be equal to 0.003, which agrees with many tests of beams and columns. A compressive force,  $C$ , develops in the compression zone and a tension force,  $T$ , develops in the tension zone at the level of the steel bars. The position of force  $T$  is known because its line of application coincides with the center of gravity of the steel bars. The position of compressive force  $C$  is not known unless the compressive volume is known and its center of gravity is located. If that is done, the moment arm, which is the vertical distance between  $C$  and  $T$ , will consequently be known.



**Figure 3.7** Forces in a rectangular section.

In Fig. 3.7, if concrete fails,  $\epsilon_c = 0.003$ , and if steel yields, as in the case of a balanced section,  $f_s = f_y$ .

The compression force  $C$  is represented by the volume of the stress block, which has the nonuniform shape of stress over the rectangular hatched area of  $bc$ . This volume may be considered equal to  $C = bc(\alpha_1 f'_c)$ , where  $\alpha_1 f'_c$  is an assumed average stress of the nonuniform stress block.

The position of compression force  $C$  is at a distance  $z$  from the top fibers, which can be considered as a fraction of the distance  $c$  (the distance from the top fibers to the neutral axis), and  $z$  can be assumed to be equal to  $\alpha_2 c$ , where  $\alpha_2 < 1$ . The values of  $\alpha_1$  and  $\alpha_2$  have been estimated from many tests, and their values, as suggested by Mattock, Kriz, and Hognestad [2], are as follows:

$\alpha_1 = 0.72$  for  $f'_c \leq 4000$  psi (27.6 MPa); it decreases linearly by 0.04 for every 1000 psi (6.9 MPa) greater than 4000 psi

$\alpha_2 = 0.425$  for  $f'_c < 4000$  psi (27.6 MPa); it decreases linearly by 0.025 for every 1000 psi greater than 4000 psi

The decrease in the value of  $\alpha_1$  and  $\alpha_2$  is related to the fact that high-strength concretes show more brittleness than low-strength concretes [3].

To derive a simple rational approach for calculations of the internal forces of a section, the ACI Code adopted an equivalent rectangular concrete stress distribution, which was first proposed by C.S. Whitney and checked by Mattock and others [2]. A concrete stress of  $0.85 f'_c$  is assumed to be uniformly distributed over an equivalent compression zone bounded by the edges of the cross section and a line parallel to the neutral axis at a distance  $a = \beta_1 c$  from the fiber of maximum compressive strain, where  $c$  is the distance between the top of the compressive section and the neutral axis (Fig. 3.8). The fraction  $\beta_1$  is 0.85 for concrete strengths  $f'_c \leq 4000$  psi (27.6 MPa) and is reduced linearly at a rate of 0.05 for each 1000 psi (6.9 MPa) of stress greater than 4000 psi (Fig. 3.9), with a minimum value of 0.65.

The preceding discussion applies in general to any section, and it is not confined to a rectangular shape. In the rectangular section, the area of the compressive zone is equal to  $ba$ , and every unit area is acted on by a uniform stress equal to  $0.85 f'_c$ , giving a total stress volume equal to  $0.85 f'_c ab$ ,

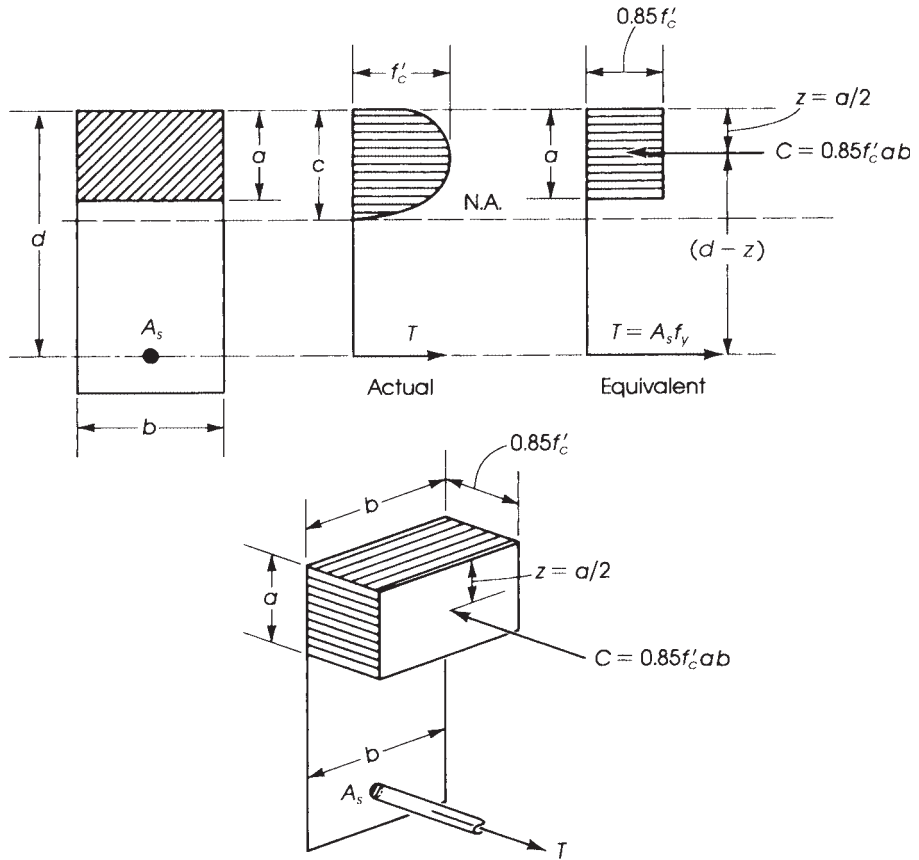


Figure 3.8 Actual and equivalent stress distributions at failure.

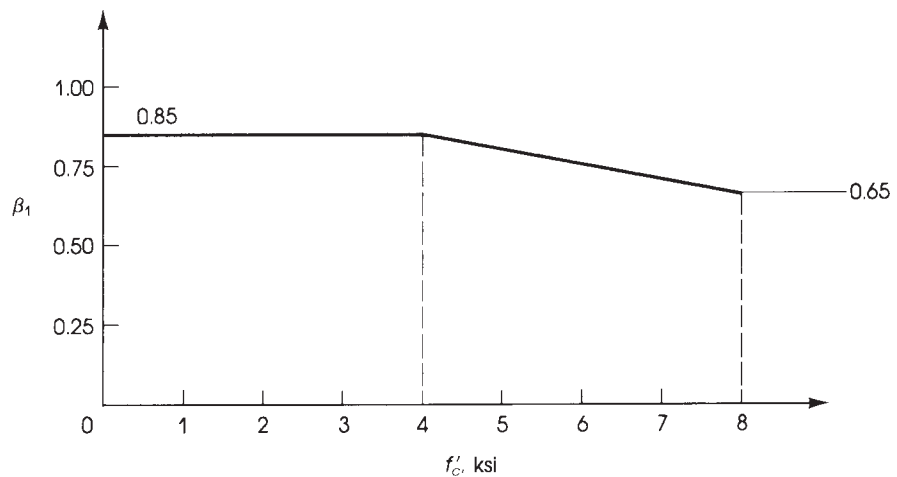
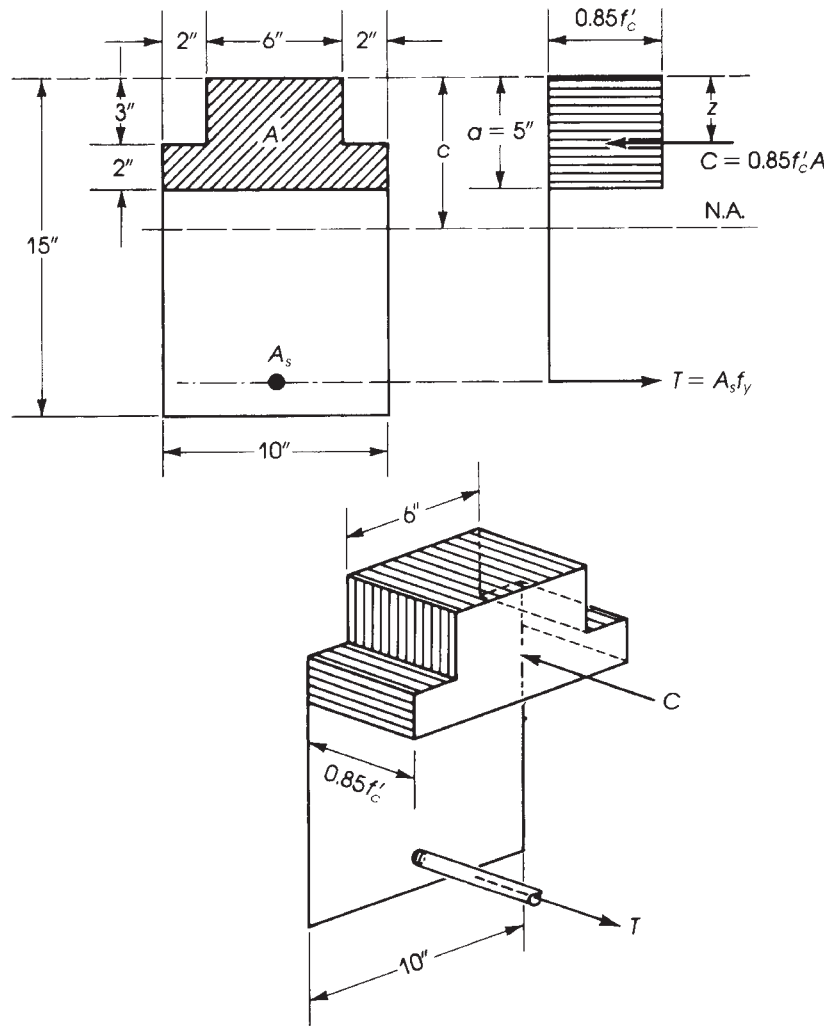


Figure 3.9 Values of  $\beta_1$  for different compressive strengths of concrete,  $f'_c$ .



**Figure 3.10** Forces in a nonrectangular section.

which corresponds to the compressive force  $C$ . For any other shape, the force  $C$  is equal to the area of the compressive zone multiplied by a constant stress equal to  $0.85f'_c$ .

For example, in the section shown in Fig. 3.10, the force  $C$  is equal to the shaded area of the cross section multiplied by  $0.85f'_c$ :

$$C = 0.85f'_c(6 \times 3 + 10 \times 2) = 32.3f'_c \text{ lb}$$

The position of the force  $C$  is at a distance  $z$  from the top fibers, at the position of the resultant force of all small-element forces of the section. As in the case when the stress is uniform and equals  $0.85f'_c$ , the resultant force  $C$  is located at the center of gravity of the compressive zone, which has a depth of  $a$ .

In this example,  $z$  is calculated by taking moments about the top fibers:

$$z = \frac{(6 \times 3 \times \frac{3}{2}) + 10 \times 2(1 + 3)}{6 \times 3 + 10 \times 2} = \frac{107}{38} = 2.82 \text{ in.}$$

### 3.9 SINGLY REINFORCED RECTANGULAR SECTION IN BENDING

We explained previously that a balanced condition is achieved when steel yields at the same time as the concrete fails, and that failure usually happens suddenly. This implies that the yield strain in the steel is reached ( $\epsilon_y = f_y/E_s$ ) and that the concrete has reached its maximum strain of 0.003. The percentage of reinforcement used to produce a balanced condition is called the *balanced steel ratio*,  $\rho_b$ . This value is equal to the area of steel,  $A_s$ , divided by the effective cross section,  $bd$ :

$$\rho_b = \frac{A_s(\text{balanced})}{bd}$$

where

$b$  = width of compression face of member

$d$  = distance from extreme compression fiber to centroid of longitudinal tension reinforcement

Two basic equations for the analysis and design of structural members are the two equations of equilibrium that are valid for any load and any section:

1. The compression force should be equal to the tension force; otherwise, a section will have linear displacement plus rotation:

$$C = T \quad (3.12)$$

2. The internal nominal bending moment,  $M_n$ , is equal to either the compressive force,  $C$ , multiplied by its arm or the tension force,  $T$ , multiplied by the same arm:

$$M_n = C(d - z) = T(d - z)$$

$$(M_u = \phi M_n \text{ after applying a reduction factor } \phi) \quad (3.13)$$

The use of these equations can be explained by considering the case of a rectangular section with tension reinforcement (Fig. 3.8). The section may be balanced, underreinforced, or overreinforced, depending on the percentage of steel reinforcement used.

#### 3.9.1 Balanced Section

Let us consider the case of a balanced section, which implies that at maximum load the strain in concrete equals 0.003 and that of steel equals the first yield stress at distance  $d_t$  divided by the modulus of elasticity of steel,  $f_y/E_s$ . This case is explained by the following steps.

**Step 1.** From the strain diagram of Fig. 3.11,

$$\frac{c_b}{d_t - c_b} = \frac{0.003}{f_y/E_s}$$

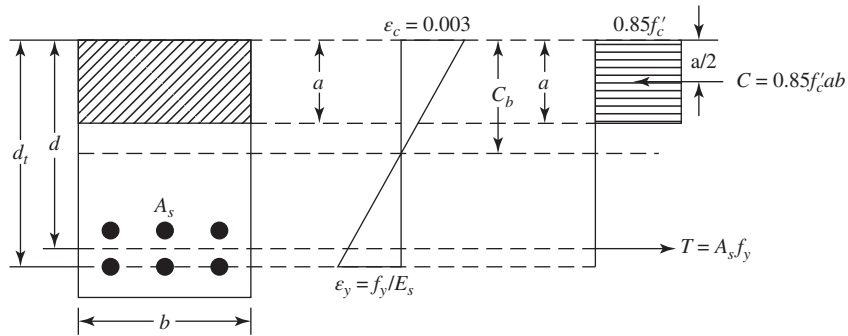
From triangular relationships (where  $c_b$  is  $c$  for a balanced section) and by adding the numerator to the denominator,

$$\frac{c_b}{d_t} = \frac{0.003}{0.003 + f_y/E_s}$$

Substituting  $E_s = 29 \times 10^3$  ksi,

$$c_b = \left( \frac{87}{87 + f_y} \right) d_t \quad (f_y \text{ in ksi}) \quad (3.14)$$

where  $f_y$  is in ksi.



**Figure 3.11** Rectangular balanced section.

**Step 2.** From the equilibrium equation,

$$C = T \quad 0.85f'_c ab = A_s f_y \quad (3.15)$$

$$a = \frac{A_s f_y}{0.85f'_c b} \quad (3.16)$$

Here,  $a$  is the depth of the compressive block, equal to  $\beta_1 c$ , where  $\beta_1 = 0.85$  for  $f'_c \leq 4000$  psi (27.6 MPa) and decreases linearly by 0.05 per 1000 psi (6.9 MPa) for higher concrete strengths (Fig. 3.9). Because the balanced steel reinforcement ratio is used,

$$\rho_b = \frac{A_s(\text{balanced})}{bd} = \frac{A_{sb}}{bd} \quad (3.17)$$

and substituting the value of  $A_{sb}$  in Eq. 3.15,

$$0.85f'_c ab = f_y \rho_b bd$$

Therefore,

$$\rho_b = \frac{0.85f'_c}{f_y d} a = \frac{0.85f'_c}{f_y d} (\beta_1 c_b)$$

Substituting the value of  $c_b$  from Eq. 3.14, the general equation of the balanced steel ratio becomes

$$\rho_b = 0.85\beta_1 \frac{f'_c}{f_y} \left( \frac{87}{87 + f_y} \right) \left( \frac{d_t}{d} \right) \quad (3.18)$$

The value of  $d_t$  is equal to  $d$  when only one single layer of steel is provided.

**Step 3.** The internal nominal moment,  $M_n$ , is calculated by multiplying either  $C$  or  $T$  by the distance between them:

$$M_n = C(d - z) = T(d - z) \quad (3.13)$$

For a rectangular section, the distance  $z = d - a/2$  as the line of application of the force  $C$  lies at the center of gravity of the area  $ab$ , where

$$a = \frac{A_s f_y}{0.85f'_c b}$$

$$M_n = C \left( d - \frac{1}{2}a \right) = T \left( d - \frac{1}{2}a \right)$$



For a balanced or an underreinforced section,  $T = A_s f_y$ . Then

$$M_n = A_s f_y \left( d - \frac{1}{2} a \right) \quad (3.19)$$

To get the usable design moment  $\phi M_n$ , the previously calculated  $M_n$  must be reduced by the capacity reduction factor,  $\phi$ ,

$$\phi M_n = \phi A_s f_y \left( d - \frac{a}{2} \right) = \phi A_s f_y \left( d - \frac{A_s f_y}{1.7 f'_c b} \right) \quad (3.19a)$$

Equation 3.19a can be written in terms of the steel percentage  $\rho$ :

$$\begin{aligned} \rho &= \frac{A_s}{bd} & A_s &= \rho b d \\ \phi M_n &= \phi f_y \rho b d \left( d - \frac{\rho b d f_y}{1.7 f'_c b} \right) = \phi \rho f_y b d^2 \left( 1 - \frac{\rho f_y}{1.7 f'_c} \right) \end{aligned} \quad (3.20)$$

Equation 3.20 can be written as

$$\phi M_n = R_u b d^2 \quad (3.21)$$

where

$$R_u = \phi \rho f_y \left( 1 - \frac{\rho f_y}{1.7 f'_c} \right) \quad (3.22)$$

The ratio of the equivalent compressive stress block depth,  $a$ , to the effective depth of the section,  $d$ , can be found from Eq. 3.15:

$$\begin{aligned} 0.85 f'_c a b &= \rho b d f_y \\ \frac{a}{d} &= \frac{\rho f_y}{0.85 f'_c} \end{aligned} \quad (3.23)$$

### 3.9.2 Upper Limit of Steel Percentage

The upper limit or the maximum steel percentage,  $\rho_{\max}$ , that can be used in a singly reinforced concrete section in bending is based on the net tensile strain in the tension steel, the balanced steel ratio, and the grade of steel used. The relationship between the steel percentage,  $\rho$ , in the section and the net tensile strain,  $\epsilon_t$ , is as follows:

$$\epsilon_t = \left( \frac{0.003 + f_y/E_s}{\rho/\rho_b} \right) - 0.003 \quad (3.24)$$

For  $f_y = 60$  ksi, and assuming  $f_y/E_s = 0.002$ ,

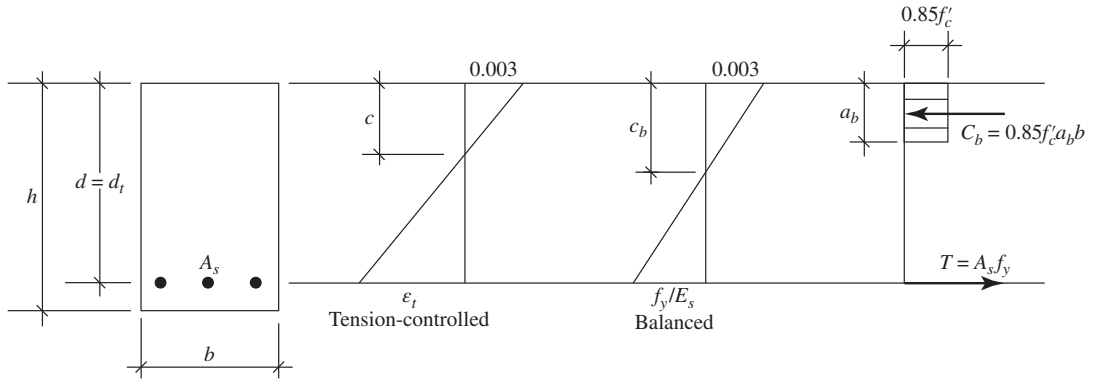
$$\epsilon_t = \left( \frac{0.005}{\rho/\rho_b} \right) - 0.003 \quad (3.25)$$

These expressions are obtained by referring to Fig. 3.12. For a balanced section,

$$c_b = \frac{a_b}{\beta_1} = \frac{A_{sb} f_y}{0.85 f'_c b \beta_1} = \frac{\rho_b f_y d}{0.85 f'_c \beta_1}$$

Similarly, for any steel ratio,  $\rho$ ,

$$c = \frac{\rho f_y d}{0.85 f'_c \beta_1} \quad \text{and} \quad \frac{c}{c_b} = \frac{\rho}{\rho_b}$$



**Figure 3.12** Strains in tension-controlled and balanced conditions. ( $d = d_t$  one layer of steel).

Divide both sides by  $d$  to get

$$\frac{c}{d} = \left( \frac{\rho}{\rho_b} \right) \left( \frac{c_b}{d} \right) \tag{3.26}$$

From the triangles of the strain diagrams,

$$\begin{aligned} \frac{c}{d} &= \frac{0.003}{0.003 + \epsilon_t} \\ \epsilon_t &= \frac{0.003}{c/d} - 0.003 \end{aligned} \tag{3.27}$$

Similarly,

$$\frac{c_b}{d} = \frac{0.003}{0.003 + f_y/E_s} \tag{3.28}$$

Substituting Eq. 3.28 into Eq. 3.26

$$\frac{c}{d} = \left( \frac{\rho}{\rho_b} \right) \left( \frac{c_b}{d} \right) = \left( \frac{\rho}{\rho_b} \right) \left( \frac{0.003}{0.003 + f_y/E_s} \right) \tag{From Eq. 3.26}$$

Substitute this value in Eq. 3.27 to get

$$\epsilon_t = \frac{0.003}{c/d} - 0.003 = \left[ \frac{0.003 + f_y/E_s}{\rho/\rho_b} \right] - 0.003 \tag{From Eq. 3.27}$$

For grade 60 steel,  $f_y = 60$  ksi,  $E_s = 29,000$  ksi, and  $f_y/E_s = 0.00207$ , then

$$\epsilon_t = \left( \frac{0.00507}{\rho/\rho_b} \right) - 0.003 \tag{From Eq. 3.25}$$

To determine the upper limit or the maximum steel percentage,  $\rho$ , in a singly reinforced concrete section, refer to Fig. 3.6. It can be seen that concrete sections subjected to flexure or axial load and bending moment may lie in compression-controlled, transition, or tension-controlled zones. When  $\epsilon_t \leq 0.002$  (or  $c/d_t \geq 0.6$ ), compression controls, whereas when  $\epsilon_t \geq 0.005$  (or  $c/d_t \leq 0.375$ ), tension controls. The transition zone occurs when  $0.002 < \epsilon_t < 0.005$  or  $0.6 > c/d_t > 0.375$ .

For members subjected to flexure, the relationship between the steel ratio,  $\rho$ , was given in Eq. 3.24:

$$\varepsilon_t + 0.003 = \frac{0.003 + f_y/E_s}{\rho/\rho_b} \quad (3.24)$$

or

$$\frac{\rho}{\rho_b} = \frac{0.003 + f_y/E_s}{0.003 + \varepsilon_t} \quad (3.29)$$

For  $f_y = 60$  ksi and  $E_s = 29,000$  ksi,  $f_y/E_s$  may be assumed to be 0.00207.

$$\frac{\rho}{\rho_b} = \frac{0.00507}{0.003 + \varepsilon_t} \quad (3.30)$$

The limit for tension to control is  $\varepsilon_t \geq 0.005$  according to ACI. For  $\varepsilon_t = 0.005$ , Eq. 3.30 becomes

$$\frac{\rho}{\rho_b} = \frac{0.005}{0.008} = \frac{5}{8} = 0.625 \quad (3.30a)$$

or  $\rho \leq 0.63375 \rho_b$  for tension-controlled sections if  $\varepsilon_t = 0.00507 = f_y/E_s$ . Both values can be used for practical analysis and design. The small increase in  $\rho$  will slightly increase the moment capacity of the section. For example, if  $f'_c = 4$  ksi and  $f_y = 60$  ksi,  $\rho_b = 0.0285$  and  $\rho \leq 0.01806$  for tension to control (as in the case of flexural members). The  $\phi$  factor in this case is 0.9. This value is less than  $\rho_{\max} = 0.75\rho_b = 0.0214$  allowed by the ACI Code for flexural members when  $\phi = 0.9$  can be used.

Design of beams and other flexural members can be simplified using the limit of  $\varepsilon_t = 0.005$ .

$$\frac{\rho}{\rho_b} = \frac{0.003 + f_y/E_s}{0.008} \quad (3.31)$$

In this case,  $\rho = \rho_{\max}$  = upper limit for tension-controlled sections.

$$\rho_{\max} = \left( \frac{0.003 + f_y/E_s}{0.008} \right) \rho_b \quad (3.31a)$$

Note that when  $\rho$  used  $\leq \rho_{\max}$ , tension controls and  $\phi = 0.9$ . When  $\rho > \rho_{\max}$ , the section will be in the transition region with  $\phi < 0.9$ .

And for  $f_y = 60$  ksi and  $f_y/E_s = 0.00207$ ,

$$\frac{\rho_{\max}}{\rho_b} = 0.63375 \quad (3.32)$$

This steel ratio will provide adequate ductility before beam failure.

Similarly,

$$\rho_{\max} = \begin{cases} 0.5474\rho_b & \text{for } f_y = 40 \text{ ksi} & (3.32a) \\ 0.5905\rho_b & \text{for } f_y = 50 \text{ ksi} & (3.32b) \\ 0.6983\rho_b & \text{for } f_y = 75 \text{ ksi} & (3.32c) \end{cases}$$

It was established that  $\phi M_n = R_u b d^2$  (Eq. 3.21), where  $R_u = \phi \rho f_y (1 - \rho f_y / 1.7 f'_c)$  (Eq. 3.22). Once  $f'_c$  and  $f_y$  are known, then  $\rho_b$ ,  $\rho$ ,  $R_u$ , and  $b d^2$  can be calculated. For example, for  $f'_c = 4$  ksi,  $f_y = 60$  ksi,  $\phi = 0.9$ ,  $\varepsilon_t = 0.005$ , and one row of bars in the section,

$$\rho_b = 0.0285 \quad \rho = 0.01806 \quad R_u = 820 \text{ psi}$$

**Table 3.2** Values of  $\rho_{\max}$  and  $R_u = M_u/bd^2$  for Flexural Tension-Controlled Sections with One Row of Bars,  $\varepsilon_t = 0.005$ 

$f'_c$ (ksi)	$f_y$ (ksi)	$\rho_b$	$\rho_{\max} = 0.63375 \rho_b$	$R_u$ (psi) (Eq. 3.22)
3	60	0.0214	0.01356	615
4	60	0.0285	0.01806	820
5	60	0.0335	0.02123	975
6	60	0.0377	0.02389	1109

Note that for one row of bars in the section, it can be assumed that  $d = d_t = h - 2.5$  in., whereas for two rows of bars,  $d = h - 3.5$  in., and  $d_t = h - 2.5$  in.  $= d + 1.0$  in. (Refer to Figs. 3.4 and 3.5 and Section 4.3.3.)

Table 3.2 gives the values of  $\rho$ ,  $\rho_b$ , and  $R_u = M_u/bd^2$  for flexural tension-controlled sections with one row of bars.

For reinforced concrete flexural members with  $\rho > \rho_{\max}$ ,  $\varepsilon_t$  will be less than 0.005. Section 9.3.3.1 of the ACI Code specifies that  $\varepsilon_t$  should not be less than 0.004 in the transition region to maintain adequate ductility and warning before failure.

For this limitation of  $\varepsilon_t = 0.004$ , the general equation (3.29) becomes

$$\frac{\rho}{\rho_b} = \frac{0.003 + f_y/E_s}{0.007} \quad (3.33)$$

For  $f_y = 60$  ksi,

$$\frac{\rho}{\rho_b} = \frac{0.003 + 0.00207}{0.007} = 0.724 \quad (3.34)$$

and the limit in the transition region is

$$\rho_{\max t} = 0.724 \rho_b \quad (3.34a)$$

Note that the  $t$  here refers to the transition region. In this case, limit of  $\phi_t$  is

$$\phi_t = 0.65 + (\varepsilon_t - 0.002) \left( \frac{250}{3} \right) = 0.817 < 0.9 \quad (3.35)$$

For  $f_y = 60$  ksi and  $f'_c = 4$  ksi,  $\rho_b = 0.0285$ ,  $\rho_{\max t} = 0.02063$ ,  $R_n = 1012$  psi (from Eq. 3.22), and  $R_u = \phi R_n = 0.817(1012) = 826$  psi.

This steel ratio in Eq. 3.33 is the upper limit ( $\rho_{\max t}$ ) for a singly reinforced concrete section in the transition region with  $\phi < 0.9$ .

It can be noticed that the aforementioned  $R_u = 826$  psi calculated for  $\varepsilon_t = 0.004$  is very close to  $R_u = 820$  psi for  $\rho_{\max} = 0.63375 \rho_b$  and  $\phi = 0.9$ . Therefore, adding reinforcement beyond  $\rho_{\max}$  (for  $\varepsilon_t = 0.005$ , Table 3.2) reduces  $\phi$  because of the reduced ductility resulting in little or nonsubstantial gain in design strength. Adding compression reinforcement in the section is a better solution to increase the design moment, keeping the section in the tension-controlled region with  $\phi = 0.9$ . (Refer to Section 3.14.)

Table 3.3 gives the values of  $\rho_t(\text{limit})$ ,  $\rho_b$ , and  $R_u$  for flexural members in the transition region for  $f_y = 60$  ksi and  $\varepsilon_t = 0.004$  and one row of bars. In this case  $\phi = 0.817$  (Eq. 3.35) and  $\rho/\rho_b = 0.724$ . It is clear that for  $f_y = 60$  ksi, the design  $R_u$  in both cases, when  $\varepsilon_t = 0.005$  with  $\phi = 0.9$  and when  $\varepsilon_{\max} = 0.004$  with  $\phi = 0.816$ , are quite close.

**Table 3.3** Values of  $\rho_t$  and  $R_u$  for Sections in Transition Region with  $\epsilon_t = 0.004$ ,  $f_y = 60$  ksi, and One Row of Bars ( $\phi = 0.817$ )

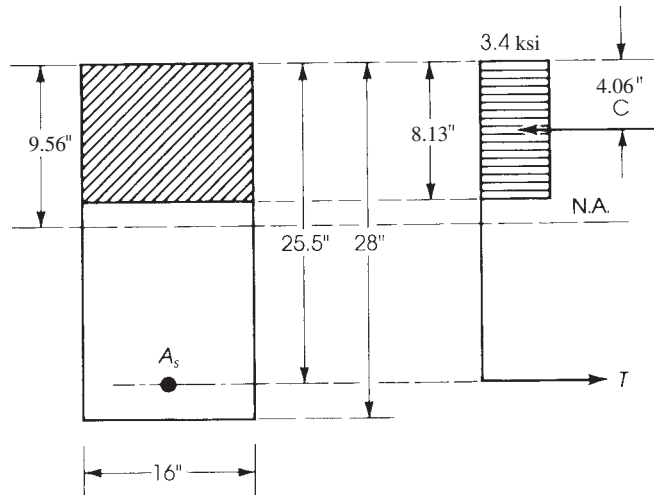
$f'_c$ (ksi)	$\rho_b$	$\rho_t$ (limit)	$R_u$ (psi)
3	0.0214	0.0155	617
4	0.0285	0.0206	822
5	0.0335	0.0243	980
6	0.0377	0.0273	1116

### Example 3.1

For the section shown in Fig. 3.13, calculate

- The balanced steel reinforcement
- The maximum reinforcement area allowed by the ACI Code for a tension-controlled section and in the transition region
- The position of the neutral axis and the depth of the equivalent compressive stress block for the tension-controlled section in  $b$ .

Given:  $f'_c = 4$  ksi and  $f_y = 60$  ksi.



**Figure 3.13** Example 3.1.

### Solution

$$\text{a.} \quad \rho_b = 0.85\beta_1 \frac{f'_c}{f_y} \left( \frac{87}{87 + f_y} \right)$$

Because  $f'_c = 4000$  psi,  $\beta_1 = 0.85$ :

$$\rho_b = (0.85)^2 \left( \frac{4}{60} \right) \left( \frac{87}{87 + 60} \right) = 0.0285$$

The area of steel reinforcement to provide a balanced condition is

$$A_{sb} = \rho_b bd = 0.0285 \times 16 \times 25.5 = 11.63 \text{ in.}^2$$

- b. For a tension-controlled section,  $\rho_{\max} = 0.63375$ ,  $\rho_b = 0.63375 \times 0.0285 = 0.01806$  or, from Eq. 3.32,

$$A_{s \max} = \rho_{\max} bd = 0.01806 \times 16 \times 25.5 = 7.37 \text{ in.}^2 \quad \text{for } \phi = 0.9$$

For the transition region,  $\rho_{\max t} = 0.724 \rho_b = 0.0206$ . For the case of  $\epsilon_t = 0.004$ ,  $A_{s \max t} = 0.0206(16 \times 25.5) = 8.41 \text{ in.}^2$  for  $\phi = 0.817$

- c. The depth of the equivalent compressive block using  $A_{s \max}$  is

$$a_{\max} = \frac{A_{s \max} f_y}{0.85 f'_c b} = \frac{7.37 \times 60}{0.85 \times 4 \times 16} = 8.13 \text{ in.}$$

The distance from the top fibers to the neutral axis is  $c = a/\beta_1$ . Because  $f'_c = 4000$  psi,  $\beta_1 = 0.85$ ; thus,

$$c = \frac{8.13}{0.85} = 9.56 \text{ in.}$$

or  $c/d = 0.375$  and  $c = 0.375(25.5) = 9.56 \text{ in.}$

### Example 3.2

Determine the design moment strength and the position of the neutral axis of the rectangular section shown in Fig. 3.14 if the reinforcement used is three no. 9 bars. Given:  $f'_c = 3$  ksi and  $f_y = 60$  ksi.

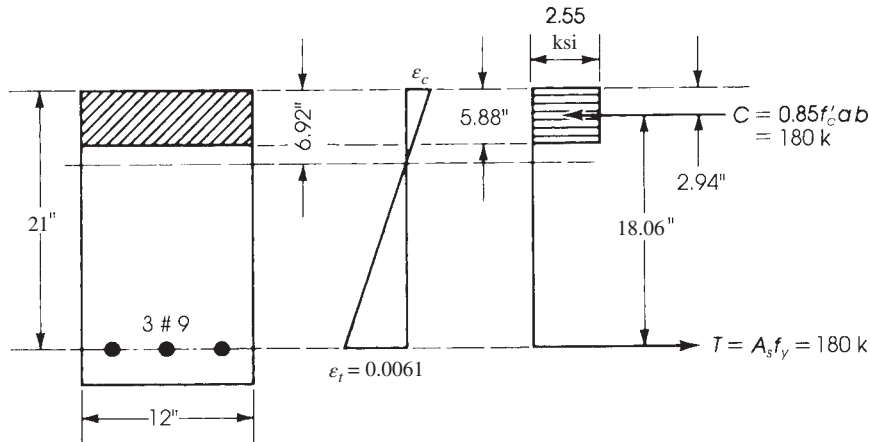


Figure 3.14 Example 3.2.

### Solution

1. The area of three no. 9 bars is  $3.0 \text{ in.}^2$

$$\rho = \frac{A_s}{bd} = \frac{3.0}{12 \times 21} = 0.0119$$

2.  $\rho_{\max} = 0.01356 > \rho$ , tension-controlled section,  $\phi = 0.9$  or check  $\epsilon_t$ :

$$a = \frac{A_s f_y}{0.85 f'_c b} = \frac{3(60)}{0.85 \times 3 \times 12} = 5.88 \text{ in.}$$

$$c = \frac{a}{0.85} = 6.92 \text{ in.}$$

$$d_t = d = 21 \text{ in.}$$

$$\epsilon_t = \left( \frac{21 - 6.92}{6.92} \right) 0.003$$

$$= 0.0061 > 0.005, \quad \phi = 0.9$$

$$\text{or } \frac{c}{d_t} = 0.33 < 0.375 \quad (\text{OK})$$

3. 
$$\phi M_n = \phi A_s f_y \left( d - \frac{1}{2} a \right)$$

$$a = \frac{A_s f_y}{0.85 f'_c b} = \frac{3.0 \times 60}{0.85 \times 3 \times 12} = 5.88 \text{ in.}$$

$$\phi M_n = 0.9 \times 3.0 \times 60 \left( 21 - \frac{5.88}{2} \right) = 2926 \text{ K} \cdot \text{in.} = 243.8 \text{ K} \cdot \text{ft}$$

### Discussion

In this example, the section is tension controlled, which implies that the steel will yield before the concrete reaches its maximum strain. A simple check can be made from the strain diagram (Fig. 3.14). From similar triangles,

$$\frac{\epsilon_c}{\epsilon_y} = \frac{c}{d - c} \quad \text{and} \quad \epsilon_y = \frac{f_y}{E_s} = \frac{60}{29,000} = 0.00207$$

$$\epsilon_c = \frac{6.92}{21 - 6.92} \times 0.00207 = 0.00102$$

which is much less than 0.003. Therefore, steel yields before concrete reaches its limiting strain of 0.003.

### Example 3.3

Repeat Example 3.2 using three no. 10 bars as the tension steel (Fig. 3.15).

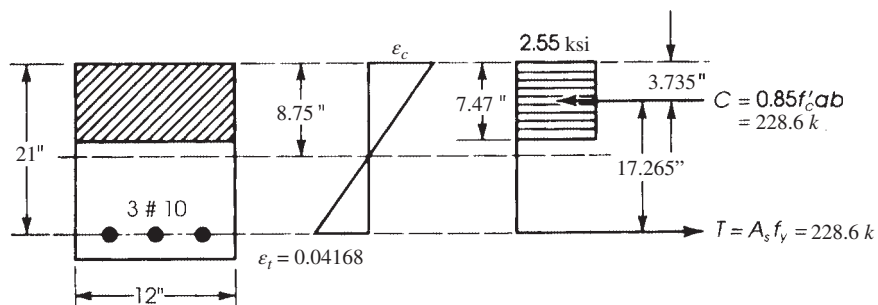


Figure 3.15 Example 3.3.

**Solution**

1. Check
- $\epsilon_t$
- :

$$a = \frac{A_s f_y}{0.85 f'_c b} = \frac{3.81(60)}{0.85 \times 3 \times 12} = 7.47 \text{ in.}$$

$$c = \frac{a}{0.85} = 8.79 \text{ in.} \quad d_t = d = 21 \text{ in.} \quad \frac{c}{d_t} = 0.419 > 0.375$$

$$\epsilon_t = \left( \frac{d_t - c}{c} \right) 0.003 = \left( \frac{21 - 8.79}{8.79} \right) 0.003 = 0.004168$$

This value is less than 0.005 but greater than 0.004 (transition region),  $\phi < 0.9$ .

$$\phi = 0.65 + (\epsilon_t - 0.002) \left( \frac{250}{3} \right) = 0.831$$

2. Calculate
- $\phi M_n$
- :

$$\phi M_n = 0.831(3.81)(60) \left[ 21 - \frac{7.47}{2} \right] = 3278 \text{ K} \cdot \text{in.} = 273 \text{ K} \cdot \text{ft}$$

**Discussion**

For a tension-controlled section,  $\epsilon_t = 0.005$  and  $\rho = 0.63375$ ,  $\rho_p = 0.01356$  (Table 3.2),  $\phi = 0.9$ .

$$A_s \text{ max} = 0.01356(12 \times 21) = 3.417 \text{ in.}^2 < 3.81 \text{ in.}^2$$

$$a = \frac{3.417 \times 60}{0.85 \times 3 \times 12} = 6.7 \text{ in.}$$

$$\phi M_n = 0.9 \times 3.417 \times 60 \left( 21 - \frac{6.7}{2} \right) = 271.4 \text{ K} \cdot \text{ft}$$

which is close to the above  $\phi M_n$ . This is a somewhat conservative approach.

**3.10 LOWER LIMIT OR MINIMUM PERCENTAGE OF STEEL**

If the factored moment applied on a beam is very small and the dimensions of the section are specified (as is sometimes required architecturally) and are larger than needed to resist the factored moment, the calculation may show that very small or no steel reinforcement is required. In this case, the maximum tensile stress due to bending moment may be equal to or less than the modulus of rupture of concrete  $f_r = \lambda 7.5 \sqrt{f'_c}$ . If no reinforcement is provided, sudden failure will be expected when the first crack occurs, thus giving no warning. The ACI Code, Section 9.6.1, specifies a minimum steel area,  $A_s$ ,

$$A_{s,\min} = \left( \frac{3\sqrt{f'_c}}{f_y} \right) b_w d \geq \left( \frac{200}{f_y} \right) b_w d$$

or the minimum steel ratio,  $\rho_{\min} = (3\sqrt{f'_c}/f_y) \geq 200/f_y$ , where the units of  $f'_c$  and  $f_y$  are in psi. This  $\rho$  ratio represents the lower limit. The first term of the preceding equation was specified to



accommodate a concrete strength higher than 5 ksi. The two minimum ratios are equal when  $f'_c = 4440$  psi. This indicates that

$$\rho_{\min} = \begin{cases} \frac{200}{f_y} & \text{for } f'_c < 4500 \text{ psi} \\ \frac{3\sqrt{f'_c}}{f_y} & \text{for } f'_c \geq 4500 \text{ psi} \end{cases}$$

For example, if  $f_y = 60$  ksi,  $\rho_{\min} = 0.00333$  when  $f'_c < 4500$  psi, whereas  $\rho_{\min} = 0.00353$  when  $f'_c = 5000$  psi and  $0.00387$  when  $f'_c = 6000$  psi.

In the case of a rectangular section, use  $b = b_w$  in the preceding expressions. For statically determinate T-sections with the flange in tension, as in the case of cantilever beams, the value of  $A_{s,\min}$  must be equal to or greater than following equation:

$$A_{s,\min} = \left( \frac{3\sqrt{f'_c}}{f_y} \right) (x)(d) \geq \frac{200xd}{f_y}$$

where

$x = 2 b_w$  or  $b_f$  whichever is smaller

$b_w =$  width of web

$b_f =$  width of flange

For example if  $b_f = 48$  in.,  $b_w = 16$  in.,  $d = 20$  in.,  $f'_c = 4000$  psi, and  $f_y = 60,000$  psi, then

$$A_{s,\min} = \left( \frac{3\sqrt{4000}}{60,000} \right) (32)(20) = 2.02 \text{ in.}^2$$

$$\frac{200(32)(20)}{60,000} = 2.13 \text{ in.}^2 \text{ (controls)}$$

$$A_{s,\min} = 2.13 \text{ in.}^2$$

### 3.11 ADEQUACY OF SECTIONS

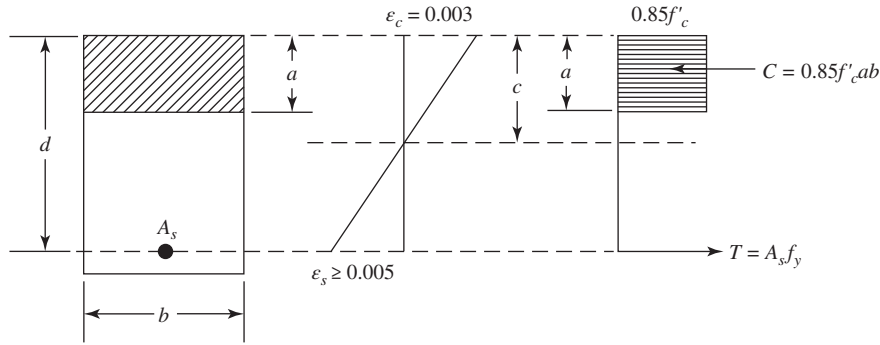
A given section is said to be *adequate* if the internal moment strength of the section is equal to or greater than the externally applied factored moment,  $M_u$ , or  $\phi M_n \geq M_u$ . The procedure can be summarized as follows:

1. Calculate the external applied factored moment,  $M_u$ .

$$M_u = 1.2M_D + 1.6M_L$$

2. Calculate  $\phi M_n$  for the basic singly reinforced section:

- a. Check that  $\rho_{\min} \leq \rho \leq \rho_{\max}$ .

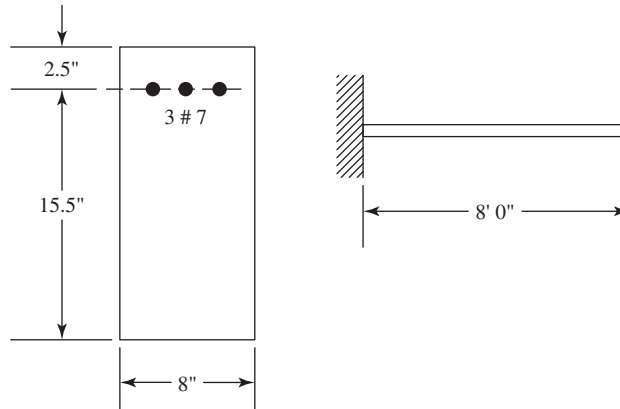


**Figure 3.16** Tension-controlled rectangular section.

- b. Calculate  $a = A_s f_y / (0.85 f'_c b)$  and check  $\epsilon_t$  for  $\phi$ .
- c. Calculate  $\phi M_n = \phi A_s f_y (d - a/2)$ .
3. If  $\phi M_n \geq M_u$ , then the section is adequate; Fig. 3.16 shows a typical tension-controlled section.

#### Example 3.4

An 8-ft-span cantilever beam has a rectangular section and reinforcement as shown in Fig. 3.17. The beam carries a dead load, including its own weight, of 1.5 K/ft and a live load of 0.9 K/ft. Using  $f'_c = 4$  ksi and  $f_y = 60$  ksi, check if the beam is safe to carry the above loads.



**Figure 3.17** Example 3.4.

#### Solution

1. Calculate the external factored moment:

$$W_u = 1.2D + 1.6L = 1.2(1.5) + 1.6(0.9) = 3.24 \text{ K/ft}$$

$$M_u = W_u \frac{L^2}{2} = 3.24 \frac{8^2}{2} = 103.68 \text{ K} \cdot \text{ft} = 1244 \text{ K} \cdot \text{in.}$$

2. Check  $\epsilon_t$ :

$$a = \frac{A_s f_y}{0.85 f'_c b} = \frac{1.8 \times 60}{0.85 \times 4 \times 8} = 3.97 \text{ in.}$$

$$c = \frac{a}{0.85} = 4.67 \text{ in.} \quad d_t = d = 15.5 \text{ in.} \quad \frac{c}{d_t} = 0.3 < 0.375$$

Also,

$$\epsilon_t = \left( \frac{d_t - c}{c} \right) 0.003 = \left( \frac{15.5 - 4.67}{4.67} \right) 0.003 = 0.007 > 0.005, \quad \phi = 0.9$$

or check

$$\rho = \frac{A_s}{bd} = \frac{1.8}{8 \times 15.5} = 0.0145 < \rho_{\max} = 0.01806$$

(from Table 3.2). Therefore, it is a tension-controlled section and  $\phi = 0.9$ .

3. Calculate  $\phi M_n$ :

$$\begin{aligned} \phi M_n &= \phi A_s f_y \left( d - \frac{1}{2} a \right) \\ &= 0.9(1.8)(60) \left( 15.5 - \frac{3.97}{2} \right) = 1312 \text{ K} \cdot \text{in.} > M_u \end{aligned}$$

Then the section is adequate.

### Example 3.5

A simply supported beam has a span of 20 ft. If the cross section of the beam is as shown in Fig. 3.18,  $f'_c = 3$  ksi, and  $f_y = 60$  ksi, determine the allowable uniformly distributed service live load on the beam assuming the dead load is that due to beam weight. Given:  $b = 12$  in.,  $d = 17$  in., total depth  $h = 20$  in., and reinforced with three no. 8 bars ( $A_s = 2.37$  in.<sup>2</sup>).

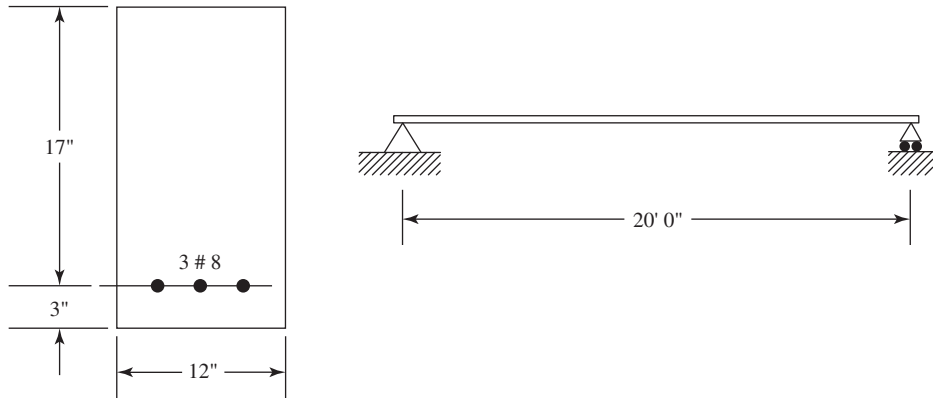


Figure 3.18 Example 3.5.

### Solution

1. Determine the design moment strength:

$$\rho = \frac{A_s}{bd} = \frac{3 \times 0.79}{12 \times 17} = 0.0116$$

$$\rho_{\max} = 0.01356 \text{ (Table 3.2)}$$

$$\rho < \rho_{\max}$$

Therefore, it is a tension-controlled section and  $\phi = 0.9$ .

Also,  $\rho > \rho_{\min} = \frac{200}{f_y} = 0.00333$ .

$$\begin{aligned} 2. \quad \phi M_n &= \phi A_s f_y \left( d - \frac{A_s f_y}{1.7 f'_c b} \right) \\ &= 0.9 \times 2.37 \times 60 \left( 17 - \frac{2.37 \times 60}{1.7 \times 3 \times 12} \right) = 1878 \text{ K} \cdot \text{in.} = 156.5 \text{ K} \cdot \text{ft} \end{aligned}$$

3. The dead load acting on the beam is self-weight (assumed):

$$w_D = \frac{12 \times 20}{144} \times 150 = 250 \text{ lb/ft} = 0.25 \text{ K/ft}$$

where 150 is the weight of reinforced concrete in pcf.

4. The external factored moment is

$$\begin{aligned} M_u &= 1.2M_D + 1.6M_L \\ &= 1.2 \left( \frac{0.25}{8} \times 20^2 \right) + 1.6 \left( \frac{w_L}{8} \times 20^2 \right) = 15.0 + 80w_L \end{aligned}$$

where  $w_L$  is the uniform service live load on the beam in K/ft.

5. Internal design moment equals the external factored moment:

$$156.5 = 15.0 + 80w_L \quad \text{and} \quad w_L = 1.77 \text{ K/ft}$$

The allowable uniform service live load on the beam is 1.77 K/ft.

### Example 3.6 Minimum Steel Reinforcement

Check the design adequacy of the section shown in Fig. 3.19 to resist a factored moment  $M_u = 30 \text{ K} \cdot \text{ft}$ , using  $f'_c = 3 \text{ ksi}$  and  $f_y = 40 \text{ ksi}$ .

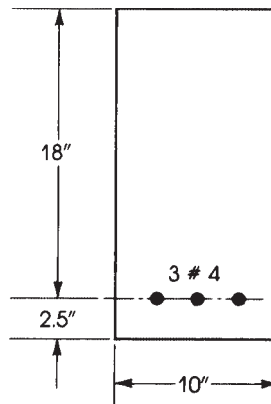


Figure 3.19 Example 3.6.

### Solution

1. Check  $\rho$  provided in the section:

$$\rho = \frac{A_s}{bd} = \frac{3 \times 0.2}{10 \times 18} = 0.00333$$

2. Check  $\rho_{\min}$  required according to the ACI Code:

$$\rho_{\min} = \frac{200}{f_y} = 0.005 > \rho = 0.00333$$

Therefore, use  $\rho = \rho_{\min} = 0.005$ .

$$A_{s,\min} = \rho_{\min}bd = 0.005 \times 10 \times 18 = 0.90 \text{ in.}^2$$

Use three no. 5 bars ( $A_s = 0.91 \text{ in.}^2$ ) because three no. 4 bars are less than the minimum specified by the code.

3. Check moment strength:  $\phi M_n = \phi A_s f_y (d - a/2)$ .

$$a = \frac{A_s f_y}{0.85 f'_c b} = \frac{0.91 \times 40}{0.85 \times 3 \times 10} = 1.43 \text{ in.}$$

$$\phi M_n = 0.9 \times 0.91 \times 40 \left( 18 - \frac{1.43}{2} \right) = 566 \text{ K} \cdot \text{in.} = 47.2 \text{ K} \cdot \text{ft}$$

4. An alternative solution; for three no. 4 bars,  $A_s = 0.6 \text{ in.}^2$  is

$$a = \frac{A_s f_y}{0.85 f'_c b} = \frac{0.6 \times 40}{0.85 \times 3 \times 10} = 0.94 \text{ in.}$$

$$\phi M_n = \frac{0.9}{12} \times 0.6 \times 40 \left( 18 - \frac{0.94}{2} \right) = 31.55 \text{ K} \cdot \text{ft}$$

$$A_s \text{ required for } 30 \text{ K} \cdot \text{ft} = \frac{30}{31.55} \times 0.6 = 0.57 \text{ in.}^2$$

The minimum  $A_s$  required according to the ACI Code, Section 9.6.1, is at least one-third greater than  $0.57 \text{ in.}^2$ :

$$\text{Minimum } A_s \text{ required} = 1.33 \times 0.57 = 0.76 \text{ in.}^2$$

which exceeds the  $0.6 \text{ in.}^2$  provided by the no. 4 bars. Use three no. 5 bars, because  $A_s = 0.91 \text{ in.}^2$  is greater than the  $0.76 \text{ in.}^2$  required.

### 3.12 BUNDLED BARS

When the design of a section requires the use of a large amount of steel—for example, when  $\rho_{\max}$  is used—it may be difficult to fit all bars within the cross section. The ACI Code, Section 25.6.1.1, allows the use of parallel bars placed in a bundled form of two, three, or four bars, as shown in Fig. 3.20. Up to four bars (no. 11 or smaller) can be bundled when they are enclosed by stirrups.

The same bundled bars can be used in columns, provided that they are enclosed by ties. All bundled bars may be treated as a single bar for checking the spacing and concrete cover requirements. The single bar diameter shall be derived from the equivalent total area of the bundled bars.

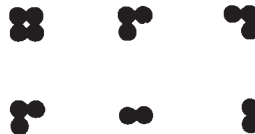


Figure 3.20 Bundled bar arrangement.

### Summary: Singly Reinforced Rectangular Section

The procedure for determining the design moment of a singly reinforced rectangular section according to the ACI Code limitations can be summarized as follows:

1. Calculate the steel ratio in the section,  $\rho = A_s/bd$ .
2. Calculate the balanced and maximum steel ratios, Eqs. 3.18 and Eqs. 3.31 or Table 3.2, for tension-controlled section. Also, calculate  $\rho_{\min} = 200/f_y$  when  $f'_c < 4500$  psi ( $f'_c$  and  $f_y$  are in psi units) and  $\rho_{\min} = 3\sqrt{f'_c}/f_y$  when  $f'_c \geq 4500$  psi.
3. If  $\rho_{\min} \leq \rho \leq \rho_{\max}$ , then the section meets the ACI Code limitations for tension-controlled section. If  $\rho \leq \rho_{\min}$ , the section is not acceptable (unless a steel ratio  $\rho \geq \rho_{\min}$  is used). If  $\rho \leq \rho_{\max}$ ,  $\phi = 0.9$  ( $\epsilon_s \leq 0.005$ ); otherwise use Fig. 3.6.
4. Calculate  $a = A_s f_y / 0.85 f'_c b$ ,  $c$ ,  $\epsilon_r$ , and  $\phi$ .
5. Calculate  $\phi M_n = \phi A_s f_y (d - a/2)$ .

Flowcharts representing this section and other sections are given at [www.wiley.com/college/hassoun](http://www.wiley.com/college/hassoun).

### 3.13 SECTIONS IN THE TRANSITION REGION ( $\phi < 0.9$ )

In the case when the NTS,  $\epsilon_t$ , in the extreme tension steel lies between the compression-controlled strain limit (0.002 for  $f_y = 60$  ksi) and the tension-controlled strain limit of 0.005, the strength reduction factor,  $\phi$ , will be less than 0.9. Consequently, the design moment strength of the section  $\phi M_n$  will be smaller than  $\phi M_n$  with  $\phi = 0.9$  (refer to Fig. 3.6). In the transition region,  $\epsilon_t$  should not be less than 0.004 for flexural members (ACI Code, Section 21.2). (See Example 3.8.)

#### Example 3.7

Determine the design moment strength of a rectangular concrete section reinforced with four no. 9 bars in one row (Fig. 3.21).

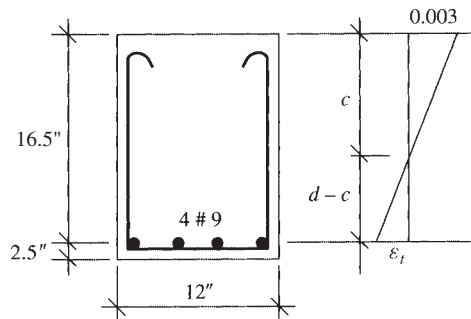


Figure 3.21 Example 3.7 ( $d = d_t$ ).

Given:  $b = 12$  in.,  $d = 16.5$  in.,  $h = 19$  in.,  $f'_c = 4$  ksi, and  $f_y = 60$  ksi.

**Solution**

- By the ACI Code provisions, for  $f'_c = 4$  ksi,  $f_y = 60$  ksi, and tension-controlled conditions ( $\rho_b = 0.0285$  and  $\rho_{\max} = 0.01806$ ), check  $\rho = A_s/bd = 4/(12 \times 16.5) = 0.02020 > \rho_{\max}$ . This indicates that the section is in the transition region and  $\phi < 0.9$ .
- Calculate  $a$ ,  $c$ , and  $\epsilon_t$ :

$$a = \frac{A_s f_y}{0.85 f'_c b} = \frac{4 \times 60}{0.85 \times 4 \times 12} = 5.882 \text{ in.}$$

$$c = \frac{a}{0.85} = 6.92 \text{ in.} \quad d_t = d = 16.5 \text{ in.} \quad \frac{c}{d_t} = 0.42 > 0.375$$

$$\epsilon_t = \left( \frac{d_t - c}{c} \right) 0.003 = \left( \frac{16.5 - 6.92}{6.92} \right) 0.003 = 0.004153 > 0.004$$

$$\phi = 0.65 + (\epsilon_t - 0.002) \left( \frac{250}{3} \right) = 0.829$$

- Calculate:

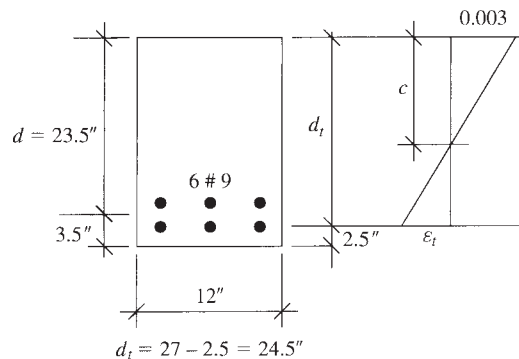
$$\begin{aligned} \phi M_n &= \phi A_s f_y \left( d - \frac{1}{2} a \right) \\ &= 0.829(4)(60) \frac{16.5 - 5.882/2}{12} = 224.9 \text{ K} \cdot \text{ft} \end{aligned}$$

**Discussion**

A slightly conservative approach can be used assuming tension-controlled section,  $\rho = \rho_{\max} = 0.01806$  and  $\phi = 0.9$ .  $A_{s,\max} = 0.01806(12 \times 16.5) = 3.576 \text{ in.}^2$ ,  $a = 5.259 \text{ in.}$ , and  $\phi M_n = 223.2 \text{ K} \cdot \text{ft}$  (almost equal to the above  $\phi M_n$ ).

**Example 3.8 Two Rows of Bars**

Determine the design moment strength of a rectangular concrete section reinforced with six no. 9 bars in two rows (Fig. 3.22).

**Figure 3.22** Example 3.8.

Given:  $b = 12 \text{ in.}$ ,  $d = 23.5 \text{ in.}$ ,  $h = 27 \text{ in.}$ ,  $d_t = 24.5 \text{ in.}$ ,  $f'_c = 4 \text{ ksi}$ , and  $f_y = 60 \text{ ksi}$ .

**Solution**

1. For tension-controlled condition,  $\epsilon_t = 0.005$ ,  $\rho_{\max} = 0.01806$  (Table 3.2), and  $\rho_b = 0.0285$ . Check

$$\rho = \frac{A_s}{bd} = \frac{6}{12 \times 23.5} = 0.02128 > \rho_{\max}$$

Section is in the transition region.

2. Calculate  $a$ ,  $c$ , and  $\epsilon_t$ :

$$a = \frac{A_s f_y}{0.85 f'_c b} = \frac{6 \times 60}{0.85 \times 4 \times 12} = 8.824 \text{ in.}$$

$$c = \frac{a}{0.85} = 10.38 \text{ in.} \quad d_t = h - 2.5 = 27 - 2.5 = 24.5$$

$$\frac{c}{d_t} = 0.424 > 0.375$$

$$\epsilon_t = \left( \frac{d_t - c}{c} \right) 0.003 = \left( \frac{24.5 - 10.38}{10.38} \right) 0.003 = 0.00408 > 0.004$$

$$\phi = 0.65 + (\epsilon_t - 0.002) \left( \frac{250}{3} \right) = 0.823$$

3. Calculate:

$$\begin{aligned} \phi M_n &= \phi A_s f_y \left( d - \frac{1}{2} a \right) \\ &= 0.823(6)(60) \frac{23.5 - 8.824/2}{12} = 471 \text{ K} \cdot \text{ft} \end{aligned}$$

**Discussion**

For a tension-controlled section limitation,  $\rho_{\max} = 0.01806$  and  $R_u = 820$  psi,

$$\phi M_n = R_u b d^2 = 0.82(12) \frac{(23.5)^2}{12} = 452.8 \text{ K} \cdot \text{ft}$$

This is a conservative value: It is advisable to choose adequate reinforcement to produce tension-controlled condition with  $\phi = 0.9$ .

**3.14 RECTANGULAR SECTIONS WITH COMPRESSION REINFORCEMENT**

In concrete sections proportioned to resist the bending moments resulting from external loading on a structural member, the internal moment is equal to or greater than the external moment, but a concrete section of a given width and effective depth has a minimum capacity when  $\rho_{\max}$  is used. If the external factored moment is greater than the design moment strength, more compressive and tensile reinforcement must be added.

Compression reinforcement is used when a section is limited to specific dimensions due to architectural reasons, such as a need for limited headroom in multistory buildings. Another advantage of compression reinforcement is that long-time deflection is reduced, as is explained in Chapter 6. A third use of bars in the compression zone is to hold stirrups, which are used to resist shear forces.

Two cases of doubly reinforced concrete sections will be considered, depending on whether compression steel yields or does not yield.



**3.14.1 When Compression Steel Yields**

Internal moment can be divided into two moments, as shown in Fig. 3.23. Let  $M_{u1}$  be the moment produced by the concrete compressive force and an equivalent tension force in steel,  $A_{s1}$ , acting as a basic section. Then  $M_{u2}$  is the additional moment produced by the compressive force in compression steel  $A'_s$  and the tension force in the additional tensile steel,  $A_{s2}$ , acting as a steel section.

The moment  $M_{u1}$  is that of a singly reinforced concrete basic section,

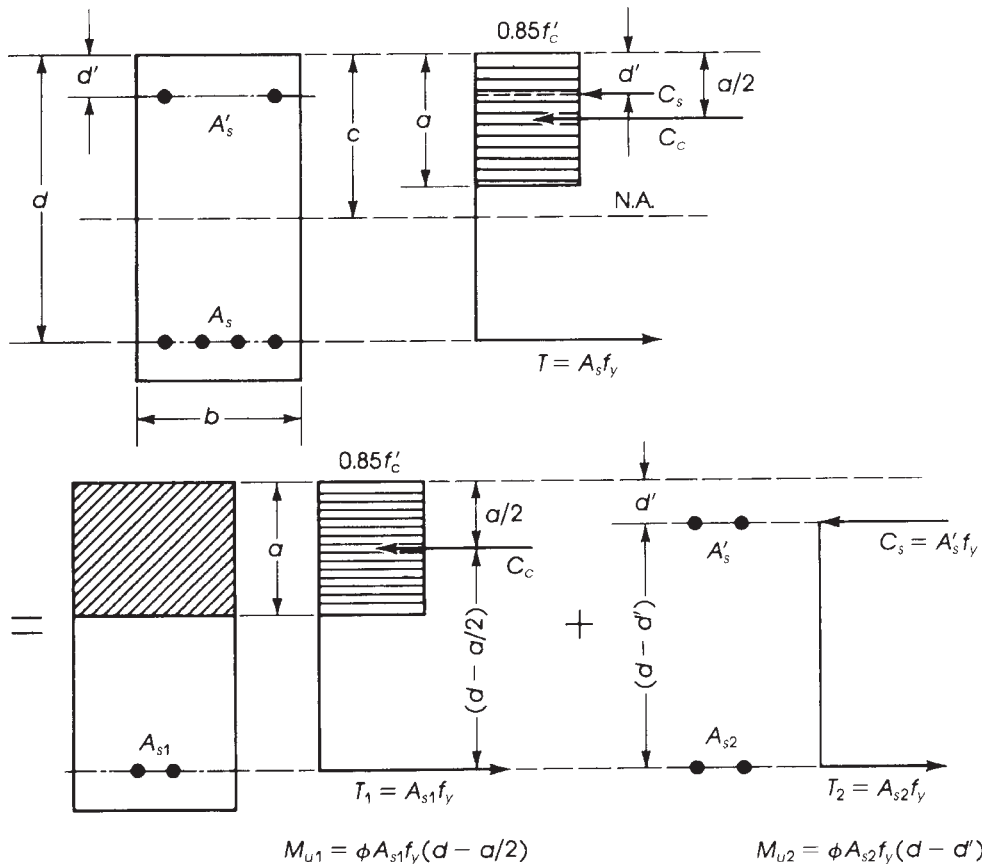
$$T_1 = C_c \tag{3.36}$$

$$A_{s1}f_y = C_c = 0.85f'_c ab \tag{3.37}$$

$$a = \frac{A_{s1}f_y}{0.85f'_c b} \tag{3.38}$$

$$M_{u1} = \phi A_{s1}f_y \left( d - \frac{a}{2} \right) \tag{3.39}$$

The restriction for  $M_{u1}$  is that  $\rho = A_{s1}/bd$  shall be equal to or less than  $\rho_{max}$  for singly reinforced tension-controlled sections, as given in Eq. 3.31a.



**Figure 3.23** Rectangular section with compression reinforcement.

Consider the moment  $M_{u2}$  and assume that the compression steel designated as  $A'_s$  yields

$$M_{u2} = \phi A_{s2} f_y (d - d') \quad (3.40a)$$

$$M_{u2} = \phi A'_s f_y (d - d') \quad (3.40b)$$

In this case  $A_{s2} = A'_s$ , producing equal and opposite forces, as shown in Fig. 3.23. The total resisting moment,  $M_u$ , is then the sum of the two moments  $M_{u1}$  and  $M_{u2}$ :

$$\phi M_n = M_{u1} + M_{u2} = \phi \left[ A_{s1} f_y \left( d - \frac{a}{2} \right) + A'_s f_y (d - d') \right] \quad (3.41)$$

The total steel reinforcement used in tension is the sum of the two steel amounts  $A_{s1}$  and  $A_{s2}$ . Therefore,

$$A_s = A_{s1} + A_{s2} = A_{s1} + A'_s \quad (3.42)$$

and

$$A_{s1} = A_s - A'_s$$

Then, substituting  $A_s - A'_s$  for  $A_{s1}$  in Eqs. 3.38 and 3.41,

$$a = \frac{(A_s - A'_s) f_y}{0.85 f'_c b} \quad (3.43)$$

$$\phi M_n = \phi \left[ (A_s - A'_s) f_y \left( d - \frac{a}{2} \right) + A'_s f_y (d - d') \right] \quad (3.44)$$

and

$$(\rho - \rho') \leq \rho_{\max} = \rho_b \left( \frac{0.003 + f_y/E_s}{0.008} \right) \quad (3.45)$$

For  $f_y = 60$  ksi,  $\rho - \rho' \leq 0.63375 \rho_b$ ,  $\phi = 0.9$ , and  $\epsilon_t = 0.005$ . Equation 3.45 must be fulfilled in doubly reinforced concrete sections, which indicates that the difference between total tension steel and the compression steel should not exceed the maximum steel for singly reinforced concrete tension-controlled sections. Failure due to yielding of the total tensile steel will then be expected, and sudden failure of concrete is avoided.

If  $\rho_1 = \rho - \rho' > \rho_{\max}$ , the section will be in the transition region with a limit of  $\rho - \rho' \leq \rho_{\max}$  (Eq. 3.34a). In this case,  $\phi < 0.9$  for  $M_{u1}$  and  $\phi = 0.9$  for  $M_{u2}$ . Equation 3.44 becomes

$$\phi M_n = \phi \left[ (A_s - A'_s) f_y \left( d - \frac{1}{2} a \right) \right] + 0.9 A'_s f_y (d - d') \quad (3.44a)$$

Note that  $(A_s - A'_s) \leq \rho_{\max} (bd)$ .

In the compression zone, the force in the compression steel is  $C_s = A'_s (f_y - 0.85 f'_c)$ , taking into account the area of concrete displaced by  $A'_s$ . In this case,

$$T = A_s f_y = C_c + C_s = 0.85 f'_c ab + A'_s (f_y - 0.85 f'_c)$$

and

$$A_s f_y - A'_s f_y + 0.85 f'_c A'_s = 0.85 f'_c ab = C_c = A_{s1} f_y \quad (\text{for the basic section})$$

Dividing by  $bd f_y$ ,

$$\rho - \rho' \left( 1 - 0.85 \frac{f'_c}{f_y} \right) = \rho_1 \quad \text{where} \quad \rho_1 = \frac{A_{s1}}{bd} \leq \rho_{\max}$$

Therefore,

$$\rho - \rho' \left( 1 - 0.85 \frac{f'_c}{f_y} \right) \leq \rho_{\max} = \rho_b \left( \frac{0.003 + f_y/E_s}{0.008} \right) \quad (3.46)$$

Although Eq. 3.46 is more accurate than Eq. 3.45, it is quite practical to use both equations to check the condition for maximum steel ratio in rectangular sections when compression steel yields.

For example, if  $f'_c = 3$  ksi and  $f_y = 60$  ksi, Eq. 3.46 becomes  $\rho - 0.9575 \rho' \leq 0.016$ ; if  $f'_c = 4$  ksi and  $f_y = 60$  ksi, then  $\rho - 0.9433 \rho' \leq 0.02138$ .

The maximum total tensile steel ratio,  $\rho$ , that can be used in a rectangular section when compression steel yields is as follows:

$$\text{Max } \rho = \rho_{\max} + \rho' \quad (3.47)$$

where  $\rho_{\max}$  is maximum tensile steel ratio for the basic singly reinforced tension-controlled concrete section. This means that maximum total tensile steel area that can be used in a rectangular section when compression steel yield is as follows:

$$\text{Max } A_s = bd(\rho_{\max} + \rho') \quad (3.47a)$$

In the preceding equations, it is assumed that compression steel yields. To investigate this condition, refer to the strain diagram in Fig. 3.24. If compression steel yields, then

$$\epsilon'_s \geq \epsilon_y = \frac{f_y}{E_s}$$

From the two triangles above the neutral axis, substitute  $E_s = 29,000$  ksi and let  $f_y$  be in ksi. Then

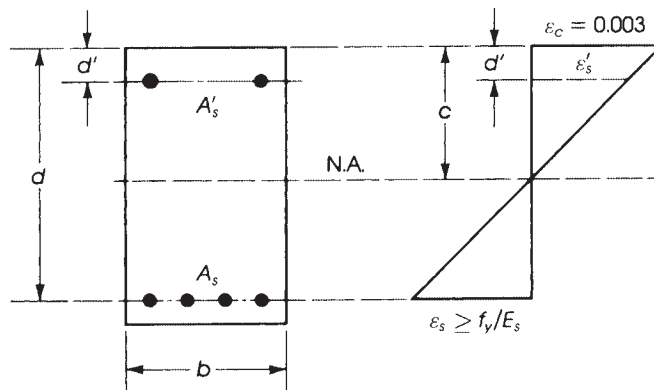
$$\begin{aligned} \frac{c}{d'} &= \frac{0.003}{0.003 - f_y/E_s} = \frac{87}{87 - f_y} \\ c &= \left( \frac{87}{87 - f_y} \right) d' \end{aligned} \quad (3.48)$$

From Eq. 3.37,

$$A_s f_y = 0.85 f'_c ab$$

but

$$A_{s1} = A_s - A'_s \quad \text{and} \quad \rho_1 = \rho - \rho'$$



**Figure 3.24** Strain diagram in doubly reinforced section.

**Table 3.4** Values of  $K$  for Different  $f'_c$  and  $f_y$ 

$f'_c$ (ksi)	$f_y$ (ksi)	$K$	$K$ (for $d' = 2.5$ in.)
3	40	$0.1003d'/d$	$0.251/d$
3	60	$0.1164d'/d$	$0.291/d$
4	60	$0.1552d'/d$	$0.388/d$
5	60	$0.1826d'/d$	$0.456/d$

Therefore, Eq. 3.37 becomes  $(A_s - A'_s)f_y = 0.85f'_c ab$ :

$$(\rho - \rho') b d f_y = 0.85 f'_c a b$$

$$\rho - \rho' = 0.85 \left( \frac{f'_c}{f_y} \right) \left( \frac{a}{d} \right)$$

Also,

$$a = \beta_1 c = \beta_1 \left( \frac{87}{87 - f_y} \right) d'$$

Therefore,

$$\rho - \rho' = 0.85 \beta_1 \left( \frac{f'_c}{f_y} \right) \left( \frac{d'}{d} \right) \left( \frac{87}{87 - f_y} \right) = K \quad (3.49)$$

The quantity  $\rho - \rho'$  is the steel ratio, or  $(A_s - A'_s)/bd = A_{s1}/bd = \rho_1$  for the singly reinforced basic section.

If  $\rho - \rho'$  is greater than the value of the right-hand side in Eq. 3.49, then compression steel will also yield. In Fig. 3.25 we can see that if  $A_{s1}$  is increased,  $T_1$  and, consequently,  $C_1$  will be greater and the neutral axis will shift downward, increasing the strain in the compression steel and ensuring its yield condition. If the tension steel used ( $A_{s1}$ ) is less than the right-hand side of Eq. 3.49, then  $T_1$  and  $C_1$  will consequently be smaller, and the strain in compression steel,  $\epsilon'_s$ , will be less than or equal to  $\epsilon_y$ , because the neutral axis will shift upward, as shown in Fig. 3.25c, and compression steel will not yield.

Therefore, Eq. 3.49 can be written

$$\rho - \rho' \geq 0.85 \beta_1 \frac{f'_c}{f_y} \times \frac{d'}{d} \times \frac{87}{87 - f_y} = K \quad (3.49a)$$

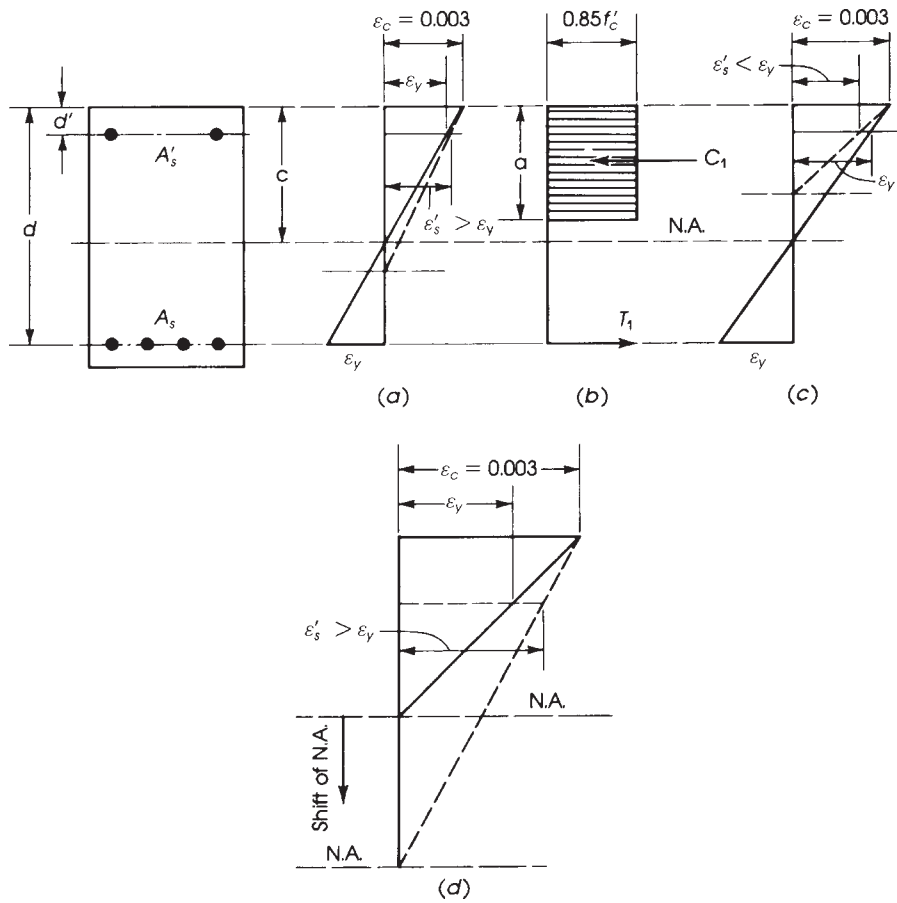
where  $f_y$  is in ksi, and this is the condition for compression steel to yield.

For example, the values of  $K$  for different values of  $f'_c$  and  $f_y$  are as shown in Table 3.4.

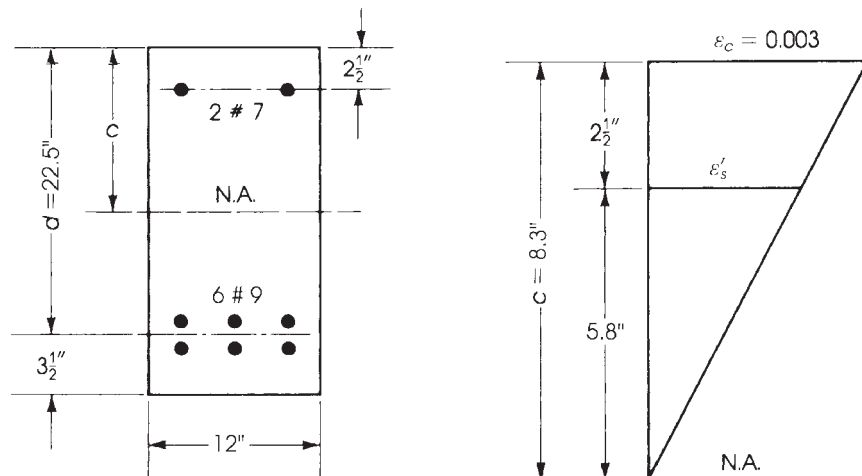
---

### Example 3.9

A rectangular beam has a width of 12 in. and an effective depth of  $d = 22.5$  in. to the centroid of tension steel bars. Tension reinforcement consists of six no. 9 bars in two rows; compression reinforcement consists of two no. 7 bars placed as shown in Fig. 3.26. Calculate the design moment strength of the beam if  $f'_c = 4$  ksi and  $f_y = 60$  ksi.



**Figure 3.25** Yielding and nonyielding cases of compression reinforcement. Diagram (d), a closeup of (a), shows how the neutral axis responds to an increase in  $A_s$ .



**Figure 3.26** Example 3.9.

**Solution**

1. Check if compression steel yields:

$$A_s = 6.0 \text{ in.}^2 \quad \rho = \frac{A_s}{bd} = \frac{6.0}{12 \times 22.5} = 0.02222$$

$$A'_s = 1.2 \text{ in.}^2 \quad \rho' = \frac{A'_s}{bd} = \frac{1.2}{12 \times 22.5} = 0.00444$$

$$A_s - A'_s = 4.8 \text{ in.}^2 \quad \rho - \rho' = 0.01778$$

For compression steel to yield,

$$\rho - \rho' \geq 0.85\beta_1 \frac{f'_c}{f_y} \times \frac{d'}{d} \times \frac{87}{87 - f_y} = K$$

Let  $\beta_1$  be 0.85 because  $f'_c = 4000$  psi; therefore,

$$K = (0.85)^2 \left(\frac{4}{60}\right) \left(\frac{2.5}{22.5}\right) \left(\frac{87}{87 - 60}\right) = 0.0175$$

$$\rho - \rho' = 0.01778 > 0.0175$$

Therefore, compression steel yields.

2. Check that  $\rho - \rho' \leq \rho_{\max}$  (Eq. 3.45): For  $f'_c = 4$  ksi and  $f_y = 60$  ksi,  $\rho_b = 0.0285$  and  $\rho_{\max} = 0.01806$  (Table 3.2). Then  $\rho - \rho' = 0.01778 < \rho_{\max}$ , and  $\phi = 0.9$  (a tension-controlled condition).
3.  $\phi M_n$  can be calculated by Eq. 3.44:

$$\phi M_n = \phi \left[ (A_s - A'_s) f_y \left( d - \frac{a}{2} \right) + A'_s f_y (d - d') \right]$$

$$a = \frac{(A_s - A'_s) f_y}{0.85 f'_c b} = \frac{4.8 \times 60}{0.85 \times 4 \times 12} = 7.06 \text{ in.}$$

$$\phi M_n = (0.9) \left[ 4.8 \times 60 \left( 22.5 - \frac{7.06}{2} \right) + 1.2 \times 60 (22.5 - 2.5) \right]$$

$$= 6213 \text{ K} \cdot \text{in.} = 517.8 \text{ K} \cdot \text{ft}$$

4. An alternative approach for checking if compression steel yields can be made as follows:

$$c = \frac{a}{0.85} = \frac{7.06}{0.85} = 8.3 \text{ in.}$$

$$\epsilon'_s = \frac{5.8}{8.3} \times 0.003 = 0.0021 \quad \epsilon_y = \frac{f_y}{E_s} = \frac{60}{29,000} = 0.00207$$

Because  $\epsilon'_s$  exceeds  $\epsilon_y$ , compression steel yields.

5. Check  $\epsilon_t$ :  $c = 8.3$  in.,  $d_t = 26 - 2.5 = 23.5$  in.

$$\epsilon_t = \left( \frac{23.5 - 8.3}{8.3} \right) 0.003 = 0.0055 > 0.005$$

or

$$\frac{c}{d} = 0.353 < 0.375 \quad (\text{OK})$$

6. The maximum total tension steel for this section,  $\max A_s$ , is equal to

$$\text{Max } A_s = bd(\rho_{\max} + \rho') = 12 \times 22.5(0.01806 + 0.00444)$$

$$= 6.08 \text{ in.}^2 A_s = 6.0 \text{ in.}^2 \quad (\text{used in the section})$$

### 3.14.2 When Compression Steel Does Not Yield

As was explained earlier, if

$$\rho - \rho' < 0.85\beta_1 \times \frac{f'_c}{f_y} \times \frac{d'}{d} \times \frac{87}{87 - f_y} = K \quad (3.50)$$

then compression steel does not yield. This indicates that if  $\rho - \rho' < K$ , the tension steel will yield before concrete can reach its maximum strain of 0.003, and the strain in compression steel,  $\epsilon'_s$ , will not reach  $\epsilon_y$  at failure (Fig. 3.25). Yielding of compression steel will also depend on its position relative to the extreme compressive fibers  $d'$ . A higher ratio of  $d'/c$  will decrease the strain in the compressive steel,  $\epsilon'_s$ , as it places compression steel  $A'_s$  nearer to the neutral axis.

If compression steel does not yield, a general solution can be performed by analysis based on statics. Also, a solution can be made as follows: Referring to 3.23 and 3.24,

$$\epsilon'_s = 0.003 \left( \frac{c - d'}{c} \right) \quad f'_s = E_s \epsilon'_s = 29,000(0.003) \left( \frac{c - d'}{c} \right) = 87 \left( \frac{c - d'}{c} \right)$$

Let  $C_c = 0.85f'_c\beta_1cb$ :

$$C_s = A'_s(f'_s - 0.85f'_c) = A'_s \left[ 87 \left( \frac{c - d'}{c} \right) - 0.85f'_c \right]$$

Because  $T = A_s f_y = C_c + C_s$ , then

$$A_s f_y = (0.85f'_c\beta_1cb) + A'_s \left[ 87 \left( \frac{c - d'}{c} \right) - 0.85f'_c \right]$$

Rearranging terms yields

$$(0.85f'_c\beta_1b)c^2 + [(87A'_s) - (0.85f'_cA'_s) - A_s f_y]c - 87A'_s d' = 0$$

This is similar to  $A_1c^2 + A_2c + A_3 = 0$ , where

$$A_1 = 0.85f'_c\beta_1b$$

$$A_2 = A'_s(87 - 0.85f'_c) - A_s f_y$$

$$A_3 = -87A'_s d'$$

Solve for  $c$ :

$$c = \frac{1}{2A_1} \left[ -A_2 \pm \sqrt{A_2^2 - 4A_1A_3} \right] \quad (3.51)$$

Once  $c$  is determined, then calculate  $f'_s$ ,  $a$ ,  $C_c$ , and  $C_s$ :

$$f'_s = 87 \left[ \frac{c - d'}{c} \right] \quad a = \beta_1 c \quad C_c = 0.85f'_c ab \quad C_s = A'_s(f'_s - 0.85f'_c)$$

$$\phi M_n = \phi \left[ C_c \left( d - \frac{1}{2}a \right) + C_s(d - d') \right] \quad (3.52)$$

When compression steel does not yield,  $f'_s < f_y$ , and the maximum total tensile steel reinforcement needed for a rectangular section is

$$\text{Max } A_s = \rho_{w,\max} bd + A'_s \frac{f'_s}{f_y} = bd \left( \rho_{w,\max} + \frac{\rho' f'_s}{f_y} \right) \quad (3.53)$$

Using steel ratios and dividing by  $bd$ :

$$\text{Max } \rho = \frac{\text{Max } A_s}{bd} \leq \rho_{w,\text{max}} + \rho' \frac{f'_s}{f_y} \quad (3.54)$$

or

$$\left( \rho - \rho' \frac{f'_s}{f_y} \right) \leq \rho_{w,\text{max}} \quad (3.55)$$

where  $\rho_{w,\text{max}}$  is the maximum steel ratio for the tension-controlled singly reinforced web section of the T-beam (Eq. 3.31).

In this case,

$$a = \frac{A_s f_y - A'_s f'_s}{0.85 f'_c b} \quad (3.56)$$

$$\phi M_n = \phi \left[ (A_s f_y - A'_s f'_s) \left( d - \frac{1}{2} a \right) + A'_s f'_s (d - d') \right] \quad (3.57)$$

In summary, the procedure for analyzing sections with compression steel is as follows:

1. Calculate  $\rho$ ,  $\rho'$ , and  $\rho - \rho'$ . Also calculate  $\rho_{\text{max}}$  and  $\rho_{\text{min}}$ .
2. Calculate

$$K = 0.85 \beta_1 \left( \frac{f'_c}{f_y} \right) \left( \frac{87}{87 - f_y} \right) \left( \frac{d'}{d} \right)$$

Use ksi units.

3. If  $\rho - \rho' \geq K$ , then compression steel yields, and  $f'_s = f_y$ ; if  $\rho - \rho' < K$ , then compression steel does not yield, and  $f'_s = f_y$ .
4. If compression steel yields, then
  - a. Check that  $\rho_{w,\text{max}} \geq \rho - \rho' \geq \rho_{w,\text{min}}$  (to use  $\phi = 0.9$ ) or check  $\epsilon_t \geq 0.005$ , where  $\rho_{w,\text{min}}$  is the minimum steel ratio for the tension-controlled singly reinforced web section of the T-beam.
  - b. Calculate

$$a = \frac{(A_s - A'_s) f_y}{0.85 f'_c b}$$

- c. Calculate

$$\phi M_n = \phi \left[ (A_s - A'_s) f_y \left( d - \frac{1}{2} a \right) + A'_s f_y (d - d') \right]$$

- d. The maximum  $A_s$  that can be used in the section is  $\text{Max } A_s = bd(\rho_{\text{max}} + \rho') \geq A_s$  (used).
5. If compression steel does *not* yield, then
  - a. Calculate the distance to the neutral axis  $c$  by using analysis (see next Example 3.10) or by using the quadratic equation 3.51.
  - b. Calculate

$$f'_s = 87 \left( \frac{c - d'}{c} \right) \text{ (ksi)}$$

- c. Check that  $\rho - \rho' f'_s / f_y \leq \rho_{w,\text{max}}$  or  $\text{max } A_s$  that can be used in the section is greater than or equal to the  $A_s$  used.

$$\text{Max } A_s = bd \left( \rho_{w,\text{max}} + \frac{\rho' f'_s}{f_y} \right) \geq A_s \text{ (used)}$$



d. Calculate

$$a = \frac{A_s f_y - A'_s f'_s}{0.85 f'_c b} \quad \text{or} \quad a = \beta_1 c$$

e. Calculate

$$\phi M_n = \phi \left[ (A_s f_y - A'_s f'_s) \left( d - \frac{1}{2} a \right) + A'_s f'_s (d - d') \right]$$

### Example 3.10

Determine the design moment strength of the section shown in Fig. 3.27 using  $f'_c = 5$  ksi,  $f_y = 60$  ksi,  $A'_s = 2.37$  in.<sup>2</sup> (three no. 8 bars), and  $A_s = 7.62$  in.<sup>2</sup> (six no. 10 bars).

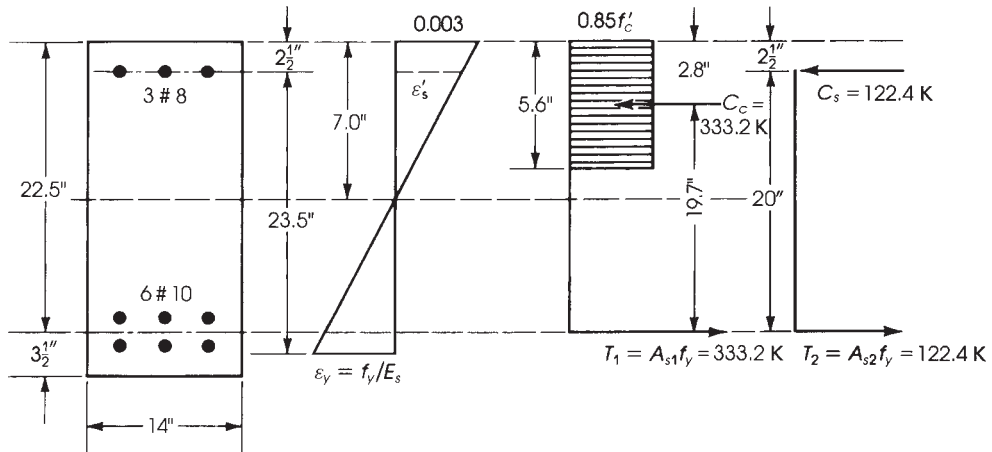


Figure 3.27 Example 3.10 analysis solution.

### Solution

1. Calculate  $\rho$  and  $\rho'$ :

$$\rho = \frac{A_s}{bd} = \frac{7.62}{14 \times 22.5} = 0.0242 \quad \rho' = \frac{A'_s}{bd} = \frac{2.37}{14 \times 22.5} = 0.00753$$

$$\rho - \rho' = 0.01667$$

2. Apply Eq. 3.50, assuming  $\beta_1 = 0.8$  for  $f'_c = 5000$  psi.

$$K = 0.85 \beta_1 \times \frac{f'_c}{f_y} \times \frac{d'}{d} \times \frac{87}{87 - f_y} = 0.85 \times 0.8 \left( \frac{5}{60} \right) \left( \frac{2.5}{22.5} \right) \left( \frac{87}{87 - 60} \right) = 0.0203$$

(or from Table 3.4,  $K = 0.456/d = 0.0203$ ):

$$\rho - \rho' = 0.01667 < 0.0203$$

Therefore, compression steel does not yield, and  $f'_s < 60$  ksi.

For  $f'_c = 5$  ksi and  $f_y = 60$  ksi, find  $\rho_b = 0.0335$  and  $\rho_{\max} = 0.02123$  (Table 3.2); then check  $(\rho - \rho') < \rho_{\max}$ , therefore  $\phi = 0.9$ , and the section is at a tension-controlled condition.

3. Calculate  $\phi M_n$  by analysis. Internal forces:

$$C_c = 0.85f'_c ab \quad a = \beta_1 c = 0.8c$$

$$C_c = 0.85 \times 5(0.8c) \times 14 = 47.6c$$

$$C_s = \text{force in compression steel}$$

$$= A'_s f'_s - \text{force in displaced concrete}$$

$$= A'_s (f'_s - 0.85f'_c)$$

From strain triangles,

$$\epsilon'_s = 0.003 \left( \frac{c - d'}{c} \right)$$

$$f'_s = E_s \epsilon'_s \text{ (since steel is in the elastic range)}$$

$$= 29,000 \left[ \frac{0.003 (c - d')}{c} \right] = \frac{87(c - d')}{c} \text{ (ksi)}$$

Therefore,

$$C_s = 2.37 \left[ 87 \frac{c - d'}{c} - (0.85 \times 5) \right] \text{ (kips)} = \left[ \frac{206.2(c - 2.5)}{c} \right] - 10.07$$

$$T = T_1 + T_2 = (A_{s1} + A_{s2})f_y = A_s f_y = 7.62(60) = 457.2 \text{ kips}$$

4. Equate internal forces to determine the position of the neutral axis (the distance  $c$ ):

$$T = C = C_c + C_s$$

$$457.2 = 47.6c + \frac{206.2(c - 2.5)}{c} - 10.07$$

$$c^2 - 5.48c - 10.83 = 0$$

$$c = 7.0 \text{ in.} \quad a = 0.8c = 5.6 \text{ in.}$$

Equation 3.51 can also be used to calculate  $c$  and  $a$ .

5. Calculate  $f'_s$ ,  $C_c$ , and  $C_s$ :

$$f'_s = \frac{87(c - 2.5)}{c} = \frac{87(7.0 - 2.5)}{7.0} = 55.9 \text{ ksi}$$

which confirms that compression steel does not yield.

$$C_c = 47.6c = 47.6(7.0) = 333.2 \text{ kips}$$

$$C_s = A'_s f'_s - 10.07 = 2.37(55.9) - 10.07 = 122.40 \text{ kips}$$

6. To calculate  $\phi M_n$ , take moments about the tension steel  $A_s$ :

$$\begin{aligned} \phi M_n &= \phi \left[ C_c \left( d - \frac{1}{2}a \right) + C_s (d - d') \right] = 0.9[333.2(22.5 - 2.8) + 122.40(22.5 - 2.5)] \\ &= 8110.8 \text{ K} \cdot \text{in.} = 675.9 \text{ K} \cdot \text{ft} \end{aligned}$$

7. Check that  $\rho - \rho' f'_s / f_y \leq \rho_{u, \max}$  (Eq. 3.55):

$$0.0242 - 0.00754 \left( \frac{55.9}{60} \right) = 0.0171 < \rho_{\max} = 0.02123$$

The maximum total tension steel that can be used in this section is calculated by Eq. 3.50:

$$\begin{aligned} \text{Max } A_s &= bd \left( \rho_{w,\text{max}} + \frac{\rho' f'_s}{f_y} \right) \\ &= 14(22.5) \left( 0.02123 + \frac{0.00753 \times 55.9}{60} \right) = 8.9 \text{ in.}^2 > 7.62 \text{ in.}^2 \quad (\text{OK}) \end{aligned}$$

8. Let  $\epsilon_t$  be checked as follows:  $c = 7.0 \text{ in.}$ ,  $d_t = 23.5 \text{ in.}$

$$\frac{c}{d_t} = 0.3 < 0.375$$

or

$$\epsilon_t = \left( \frac{d_t - c}{c} \right) 0.003 = \left( \frac{23.5 - 7}{7} \right) 0.003 = 0.0071 > 0.005$$

Tension-controlled section.

## 3.15 ANALYSIS OF T- AND I-SECTIONS

### 3.15.1 Description

It is normal to cast concrete slabs and beams together, producing a monolithic structure. Slabs have smaller thicknesses than beams. Under bending stresses, those parts of the slab on either side of the beam will be subjected to compressive stresses, depending on the position of these parts relative to the top fibers and relative to their distances from the beam. The part of the slab acting with the beam is called the flange, and it is indicated in Fig. 3.28a by area  $bt$ . The rest of the section confining the area  $(h - t)b_w$  is called the *stem*, or *web*.

In an I-section there are two flanges, a compression flange, which is actually effective, and a tension flange, which is ineffective because it lies below the neutral axis and is thus neglected completely. Therefore, the analysis and design of an I-beam is similar to that of a T-beam.

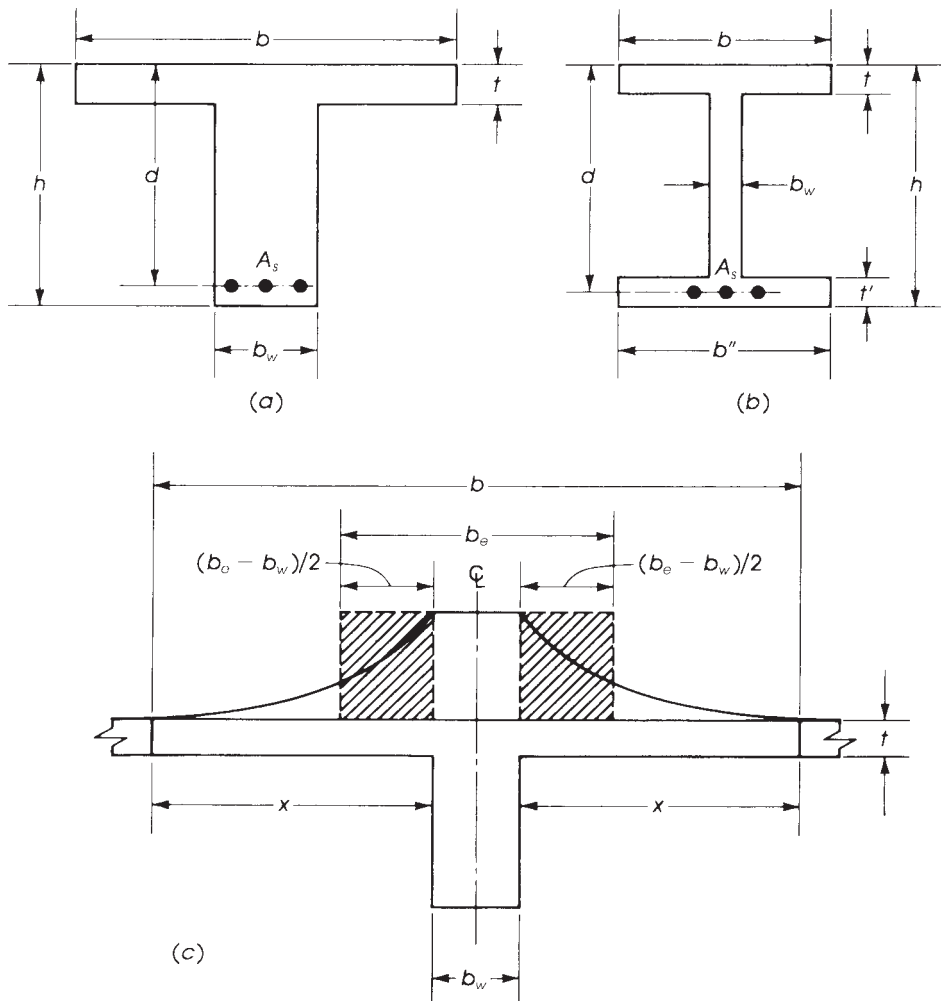
### 3.15.2 Effective Width

In a T-section, if the flange is very wide, the compressive stresses are at a maximum value at points adjacent to the beam and decrease approximately in a parabolic form to almost 0 at a distance  $x$  from the face of the beam. Stresses also vary vertically from a maximum at the top fibers of the flange to a minimum at the lower fibers of the flange. This variation depends on the position of the neutral axis and the change from elastic to inelastic deformation of the flange along its vertical axis.

An equivalent stress area can be assumed to represent the stress distribution on the width  $b$  of the flange, producing an equivalent flange width,  $b_e$ , of uniform stress (Fig. 3.28c).

Analysis of equivalent flange widths for actual T-beams indicates that  $b_e$  is a function of span length of the beam. Other variables that affect the effective width  $b_e$  are (Fig. 3.29):

- Spacing of beams
- Width of stem (web) of beam  $b_w$
- Relative thickness of slab with respect to the total beam depth
- End conditions of the beam (simply supported or continuous)
- The way in which the load is applied (distributed load or point load)
- The ratio of the length of the beam between points of zero moment to the width of the web and the distance between webs



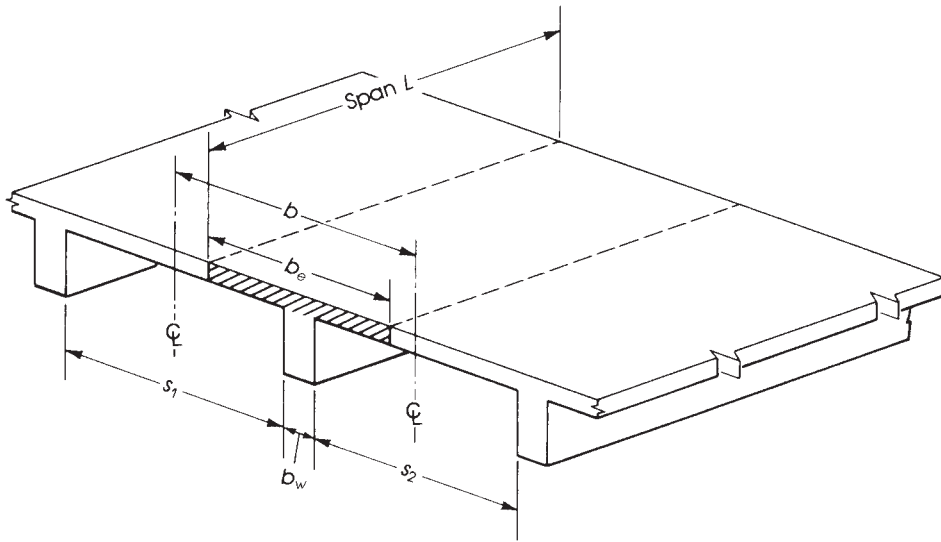
**Figure 3.28** (a) T-section and (b) I-section, with (c) illustration of effective flange width  $b_e$ .

The ACI Code, Section 6.3.2.1, prescribes the following limitations on the effective flange width  $b_e$ , considering that the span of the beam is equal to  $L$ :

1.  $b_e = L/4$
2.  $b_e = 16t + b_w$
3.  $b_e = b$ , where  $b$  is the distance between centerlines of adjacent slabs

The *smallest* of the aforementioned three values must be used.

These values are conservative for some cases of loading and are adequate for other cases. Anb similar effective width of flange can be adopted for I-beam sections. Investigations indicate that the effective compression flange increases as load is increased toward the maximum value [7]. Under working loads, stress in the flange is within the elastic range.



**Figure 3.29** Effective flange width of T-beams.

A T-shaped or I-shaped section may behave as a rectangular section or a T-section. The two cases are investigated as follows.

### 3.15.3 T-Sections Behaving as Rectangular Sections

In this case, the depth of the equivalent stress block ' $a$ ' lies within the flange, with extreme position at the level of the bottom fibers of the compression flange ( $a \leq t$ ). When the neutral axis lies within the flange (Fig. 3.30a), the depth of the equivalent compressive distribution stress lies within the flange, producing a compressed area equal to  $b_e a$ . The concrete below the neutral axis is assumed to be ineffective, and the section is considered singly reinforced, as explained earlier, with  $b$  replaced by  $b_e$ . Therefore,

$$a = \frac{A_s f_y}{0.85 f'_c b_e} \quad (3.58)$$

and

$$\phi M_n = \phi A_s f_y \left( d - \frac{a}{2} \right) \quad (3.59)$$

If the depth  $a$  is increased such that  $a = t$ , then the factored moment capacity is that of a singly reinforced concrete section:

$$\phi M_n = \phi A_s f_y \left( d - \frac{t}{2} \right) \quad (3.60)$$

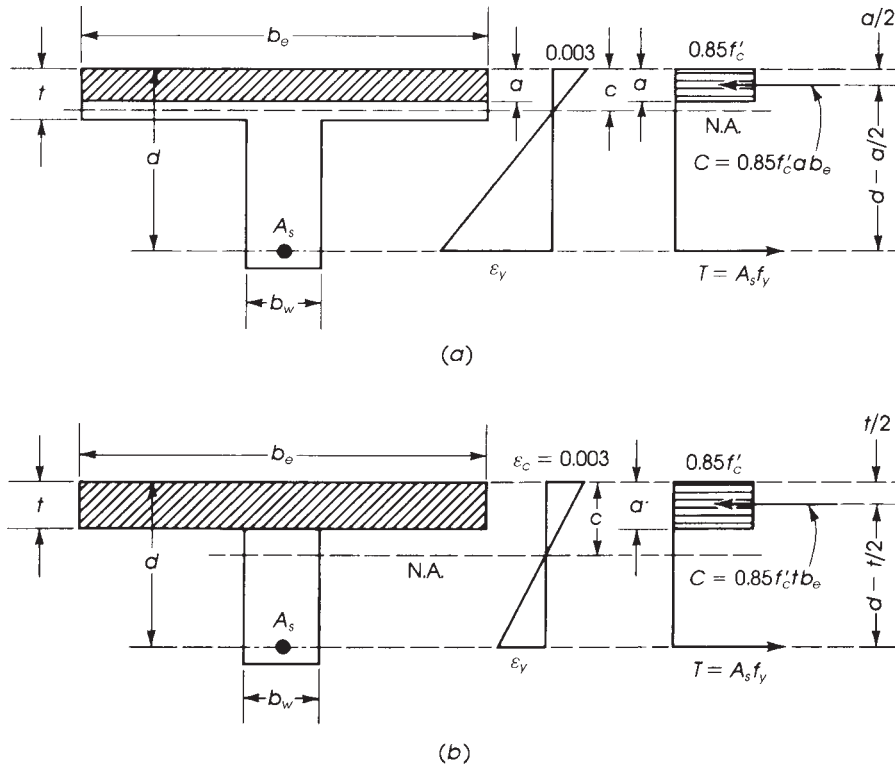
In this case

$$t = \frac{A_s f_y}{0.85 f'_c b_e} \quad \text{or} \quad A_s = \frac{0.85 f'_c b_e t}{f_y} \quad (3.61)$$

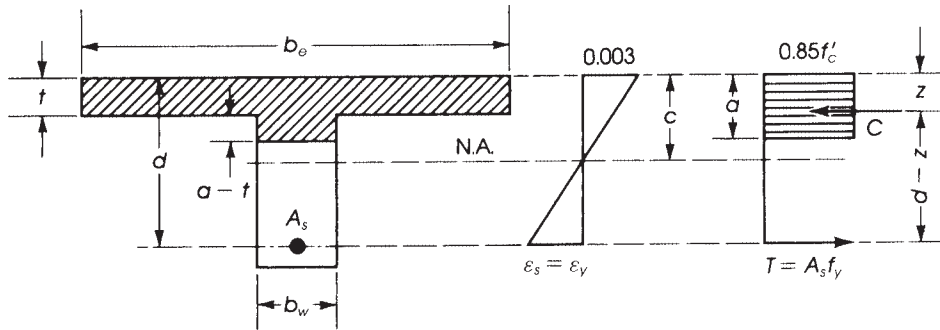
In this analysis, the limit of the steel area in the section should apply:  $A_s \leq A_{s, \max}$ , and  $\epsilon_t \geq 0.005$ .

### 3.15.4 Analysis of a T-Section

In this case the depth of the equivalent compressive distribution stress lies below the flange; consequently, the neutral axis also lies in the web. This is due to an amount of tension steel  $A_s$  more



**Figure 3.30** Rectangular section behavior (a) when the neutral axis lies within the flange and (b) when the stress distribution depth equals the slab thickness.

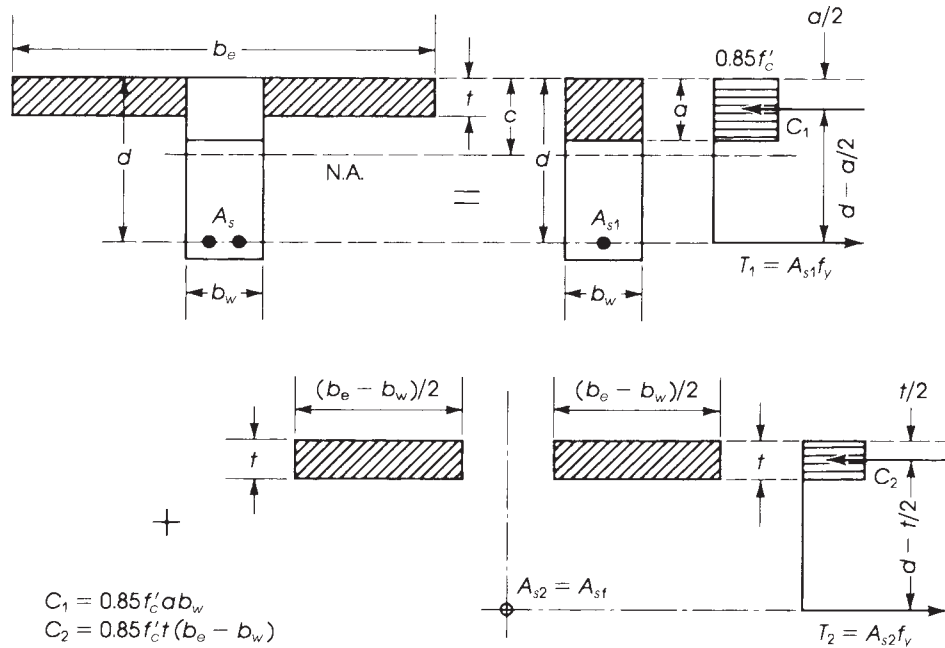


**Figure 3.31** T-section behavior.

than that calculated by Eq. 3.61. Part of the concrete in the web will now be effective in resisting the external moment. In Fig. 3.31, the compressive force  $C$  is equal to the compression area of the flange and web multiplied by the uniform stress of  $0.85f'_c$ :

$$C = 0.85f'_c [b_e t + b_w (a - t)]$$

The position of  $C$  is at the centroid of the T-shaped compressive area at a distance  $z$  from top fibers.



**Figure 3.32** T-section analysis.

The analysis of a T-section is similar to that of a doubly reinforced concrete section, considering an area of concrete  $(b_e - b_w)t$  as equivalent to the compression steel area  $A'_s$ . The analysis is divided into two parts, as shown in Fig. 3.32:

1. A singly reinforced rectangular basic section,  $b_w d$ , and steel reinforcement  $A_{s1}$ . The compressive force,  $C_1$ , is equal to  $0.85 f'_c ab_w$ , the tensile force,  $T_1$ , is equal to  $A_{s1} f_y$ , and the moment arm is equal to  $d - a/2$ .
2. A section that consists of the concrete overhanging flange sides  $2 \times [(b_e - b_w)t]/2$  developing the additional compressive force (when multiplied by  $0.85 f'_c$ ) and a moment arm equal to  $d - t/2$ . If  $A_{sf}$  is the area of tension steel that will develop a force equal to the compressive strength of the overhanging flanges, then

$$A_{sf} f_y = 0.85 f'_c (b_e - b_w) t$$

$$A_{sf} = \frac{0.85 f'_c t (b_e - b_w)}{f_y} \quad (3.62)$$

The total steel used in the T-section  $A_s$  is equal to  $A_{s1} + A_{sf}$ , or

$$A_{s1} = A_s - A_{sf} \quad (3.63)$$

The T-section is in equilibrium, so  $C_1 = T_1$ ,  $C_2 = T_2$ , and  $C = C_1 + C_2 = T_1 + T_2 = T$ . Considering equation  $C_1 = T_1$  for the basic section, then  $A_{s1} f_y = 0.85 f'_c ab_w$  or  $(A_s - A_{sf}) f_y = 0.85 f'_c ab_w$ ; therefore,

$$a = \frac{(A_s - A_{sf}) f_y}{0.85 f'_c b_w} \quad (3.64)$$

Note that  $b_w$  is used to calculate  $a$ . The factored moment capacity of the section is the sum of the two moments  $M_{u1}$  and  $M_{u2}$ :

$$\begin{aligned}\phi M_n &= M_{u1} + M_{u2} \\ M_{u1} &= \phi A_{s1} f_y \left( d - \frac{a}{2} \right) = \phi (A_s - A_{sf}) f_y \left( d - \frac{a}{2} \right)\end{aligned}$$

where

$$\begin{aligned}A_{s1} &= (A_s - A_{sf}) \quad \text{and} \quad a = \frac{(A_s - A_{sf}) f_y}{0.85 f'_c b_w} \\ M_{u2} &= \phi A_{sf} f_y \left( d - \frac{t}{2} \right) \\ \phi M_n &= \phi \left[ (A_s - A_{sf}) f_y \left( d - \frac{a}{2} \right) + A_{sf} f_y \left( d - \frac{t}{2} \right) \right] \quad (3.65)\end{aligned}$$

Considering the web section  $b_w d$ , the net tensile strain (NTS),  $\epsilon_t$ , can be calculated from  $a$ ,  $c$ , and  $d_t$  as follows:

If  $c = a/\beta_1$  (from Eq. 3.64) and  $d_t = h - 2.5$  in., then  $\epsilon_t = 0.003 [(d_t - c)/c]$ . For tension-controlled section in the web,  $\epsilon_t \geq 0.005$ .

The design moment strength of a T-section or I-section can be calculated from the preceding equation 3.65. It is necessary to check the following:

1. The total tension steel ratio relative to the web effective area is equal to or greater than  $\rho_{\min}$ :

$$\begin{aligned}\rho_w &= \frac{A_s}{b_w d} \geq \rho_{\min} \\ \rho_{\min} &= \frac{3\sqrt{f'_c}}{f_y} \geq \frac{200}{f_y} \quad (3.66)\end{aligned}$$

2. Also, check that the NTS is equal to or greater than 0.005 for tension-controlled sections.
3. The maximum tension steel (Max  $A_s$ ) in a T-section must be equal to or greater than the steel ratio used,  $A_{sf}$ , for tension-controlled sections, with  $\phi = 0.9$ .

$$\text{Max } A_s = A_{sf}(\text{flange}) + \rho_{\max}(b_w d)(\text{web}) \quad (3.67)$$

$$\text{Max } A_s = \left( \frac{1}{f_y} \right) [0.85 f'_c t (b - b_w)] + \rho_{\max}(b_w d) \quad (3.68)$$

In steel ratios, relative to the web only, divide Eq. 3.67 by  $b_w d$ :

$$\rho_w = \frac{A_s}{b_w d} \leq \rho_{\max} + \frac{A_{sf}}{b_w d} \quad (3.69)$$

or

$$\rho_w - \rho_f \leq \rho_{\max}(\text{web}) \quad (3.70)$$

where  $\rho_{\max}$  is the maximum steel ratio for the basic singly reinforced web section (Table 3.2), and  $\rho_f = A_{sf}/b_w d$ .



A general equation for calculating (Max  $A_s$ ) in a T-section when  $a < t$  can be developed as follows:

$$C = 0.85f'_c[(b_e - b_w)t + ab_w]$$

For  $\epsilon_c = 0.003$  and  $\epsilon_t = 0.005$ , then  $c/d = 0.003/(0.003 + 0.005) = 0.375$  (for the web). Hence,  $a = \beta_1 c = 0.375 \beta_1 d$

The maximum steel area is equal to  $C/f_y$  and, therefore,

$$\text{Max } A_s = \left( \frac{0.85f'_c}{f_y} \right) [(b_e - b_w)t + 0.375\beta_1 b_w d] \quad (3.71)$$

where Max  $A_s$  is the maximum tension steel area that can be used in a T-section when  $a > t$ . For example, for  $f'_c = 3$  ksi and  $f_y = 60$  ksi, the preceding equation is reduced to:

$$\text{Max } A_s = 0.0425[(b_e - b_w)t + 0.319 b_w d] \quad (3.72)$$

For  $f'_c = 4$  ksi and  $f_y = 60$  ksi,

$$\text{Max } A_s = 0.0567[(b_e - b_w)t + 0.319 b_w d] \quad (3.73)$$

In summary, the procedure to analyze a T-section, which can also be utilized for inverted L-section, described later in Section 3-17, is as follows:

1. Determine the effective width of the flange  $b_e$  (refer to Section 3.15.3). Calculate  $\rho_{\max}$  and  $\rho_{\min}$  (or take from tables).
2. Check if  $a \leq t$  as follows:  $a = A_s f_y / (0.85 f'_c b_e)$ .
3. If  $a \leq t$ , it is a rectangular section analysis.
  - a. Calculate  $\phi M_n = \phi A_s f_y (d - a/2)$ . Note that  $c = a/\beta_1$  and  $\epsilon_t = 0.003(d_t - c)/c \geq 0.005$  for tension-controlled section and  $\phi = 0.9$ .
  - b. Check that  $\rho_w = A_s/b_w d \geq \rho_{\min}$ .
  - c. Max  $A_s$  can be calculated from Eq. 3.68 and should be  $\geq A_s$  used. When  $a < t$ , normally this condition is met.
4. If  $a' > t$ , it is a T-section analysis:
  - a. Calculate  $A_{sf} = 0.85 f'_c t (b_e - b_w) / f_y$ .
  - b. Check that  $(\rho_w - \rho_f) \leq \rho_{\max}$  (relative to the web area), where

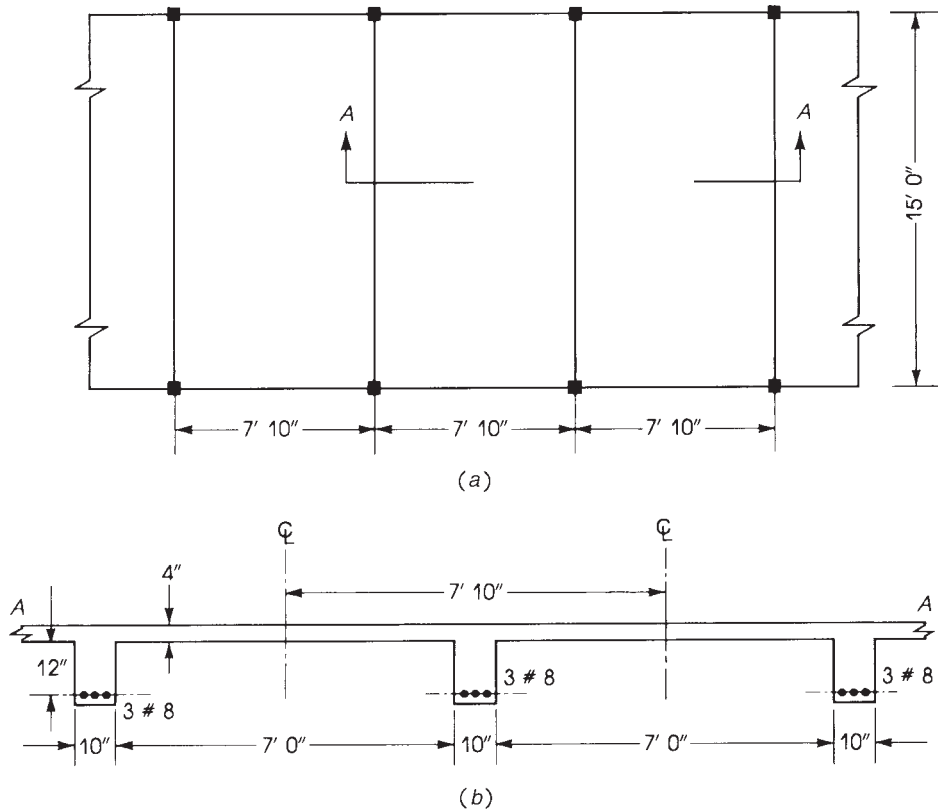
$$\rho_w = \frac{A_s}{b_w d} \quad \text{and} \quad \rho_f = \frac{A_{sf}}{b_w d}$$

Or check that Max  $A_s \geq A_s$  used in the section, for  $\phi = 0.9$ , (Eq. 3.71).

- c. Check that  $\rho_w = A_s/b_w d \geq \rho_{\min}$ . This condition is normally met when  $a > t$ .
- d. Calculate  $a = (A_s - A_{sf})f_y / 0.85 f'_c b_w$  (for the web section).
- e. Calculate  $\phi M_n$  from Eq. 3.65.

### Example 3.11

A series of reinforced concrete beams spaced at 7 ft, 10 in. on centers have a simply supported span of 15 ft. The beams support a reinforced concrete floor slab 4 in. thick. The dimensions and reinforcement of the beams are shown in Fig. 3.33. Using  $f'_c = 3$  ksi and  $f_y = 60$  ksi, determine the design moment strength of a typical interior beam.



**Figure 3.33** Example 3.11: (a) Plan of slab-beam roof and (b) section A–A.

### Solution

1. Determine the effective flange width  $b_e$ . The effective flange width is the smallest of

$$b_e = \frac{L}{4} = \frac{15}{4} \times 12 = 45 \text{ in.}$$

$$b_e = 16t + b_w = (16 \times 4) + 10 = 74 \text{ in.}$$

$$b_e = \text{Centertocenterofadjacentslabs} = (7 \times 12) + 10 = 94 \text{ in.}$$

Therefore,  $b_e = 45$  in. controls.

2. Check the depth of the stress block. If the section behaves as a rectangular one, then the stress block lies within the flange (Fig. 3.30). In this case, the width of beam used is equal to 45 in.

$$a = \frac{A_s f_y}{0.85 f'_c b_e} = \frac{2.37 \times 60}{0.85 \times 3 \times 45} = 1.24 \text{ in.} < t$$

Therefore, it is a rectangular section.

3. Check that

$$\begin{aligned} \rho_w &= \frac{A_s}{b_w d} \geq \rho_{\min} = 0.00333 \\ &= \frac{2.37}{10 \times 16} = 0.0148 > 0.00333 \end{aligned}$$

4. Check  $\epsilon_t$ :  $a = 1.24$  in.,  $c = 1.24/0.85 = 1.46$  in.,  $d_t = d = 16$  in.

$$\epsilon_t = \frac{0.003(d_t - c)}{c} = \frac{0.003(16 - 1.46)}{1.46} = 0.0299 > 0.005, \phi = 0.9$$

5. Calculate:

$$\begin{aligned} \phi M_n &= \phi A_s f_y (d - a/2) = 0.9(2.37)(60)(16 - 1.24/2) \\ &= 1968 \text{ K} \cdot \text{in.} = 164 \text{ K} \cdot \text{ft.} \end{aligned}$$

6. You may check that  $A_s$  used is less than or equal to  $\text{Max } A_s$  (Eq. 3.72), which is not needed when  $a < t$ :

$$\text{Max } A_s = 0.0425[(45 - 10) + 0.31 \times 10 \times 16] = 8.11 \text{ in.}^2; \quad A_s = 2.37 \text{ in.}^2 < \text{Max } A_s$$

### Example 3.12

Calculate the design moment strength of the T-section shown in Fig. 3.34 using  $f'_c = 3.5$  ksi and  $f_y = 60$  ksi.

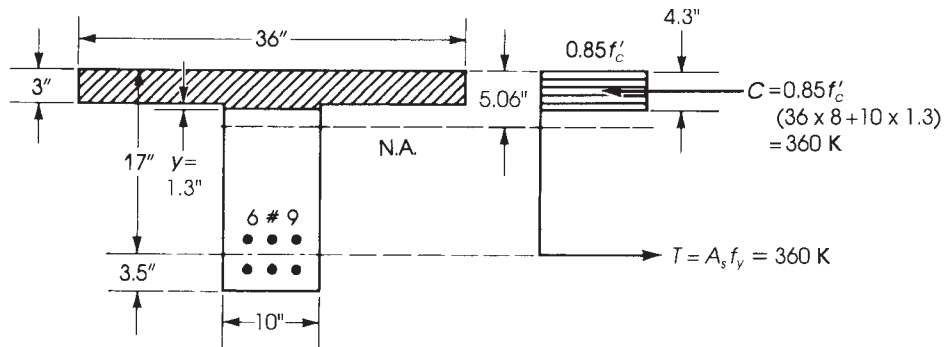


Figure 3.34 Example 3.12.

### Solution

1. Given  $b = b_e = 36$  in.,  $b_w = 10$  in.,  $d = 17$  in., and  $A_s = 6.0$  in.<sup>2</sup>, check if  $a \leq t$ :

$$a = \frac{A_s f_y}{0.85 f'_c b} = \frac{6 \times 60}{0.85 \times 3.5 \times 36} = 3.36 \text{ in.}$$

Since  $a > t$ , it is a T-section analysis.

2. Find:

$$\begin{aligned} A_{sf} &= \frac{0.85 f'_c t (b - b_w)}{f_y} = \frac{0.85 \times 3.5 \times 3 (36 - 10)}{60} = 3.87 \text{ in.}^2 (A_s - A_{sf}) = A_{s1} (\text{web}) \\ &= 6 - 3.87 = 2.13 \text{ in.}^2 \end{aligned}$$

3. Check  $\epsilon_t$ :  $a$  (web)  $= A_{s1} f_y / (0.85 f'_c b_w) = 2.13 \times 60 / (0.85 \times 3.5 \times 10) = 4.3$  in.,  $c = 4.3/0.85 = 5.06$  in.,  $d_t = 20.5 - 2.5 = 18$  in., and  $c/d_t = 0.281 < 0.375$ . Or  $\epsilon_t = 0.003(d_t - c)/c = 0.0077 > 0.005$ , then  $\phi = 0.9$

4. Check that  $A_s > A_{s, \min}$ ,  $\rho_{\min} = 0.00333$ :

$$A_{s, \min} = 0.00333 \times 10 \times 17 = 0.57 \text{ in.}^2$$

5. Calculate  $\phi M_n$  using Eq. 3.65:

$$\begin{aligned} \phi M_n &= \phi \left[ (A_s - A_{sf}) f_y \left( d - \frac{1}{2} a \right) + A_{sf} f_y \left( d - \frac{1}{2} t \right) \right] \\ &= 0.9 \left[ 2.13 \times 60 \left( 17 - \frac{4.3}{2} \right) + 3.87 \times 60 \left( 17 - \frac{3}{2} \right) \right] \\ &= 4947 \text{ K} \cdot \text{in.} = 412.3 \text{ K} \cdot \text{ft} \end{aligned}$$

Another approach to check whether  $a \leq t$  is to calculate the tension force,  $T = A_s f_y$ , and compare it to the compressive force in the total flange (Fig. 3.34):

$$T = A_s f_y = 60 \times 60 = 360 \text{ K}$$

$$C = 0.85 f'_c t b_e = 0.85 \times 3.5 \times 3 \times 36 = 321.3 \text{ K}$$

Since  $T$  exceeds  $C$ , then  $a \leq t$ , and the section acts as a T-section.

An additional area of concrete should be used to provide the difference of  $(360 - 321.3) = 38.7 \text{ K}$ . This area has a width of 10 in. and a depth of  $y$ . Therefore,

$$b_w y (0.85 f'_c) = 38.7 \text{ K} \quad \text{or} \quad 10(y)(0.85 \times 3.5) = 38.7 \text{ K}$$

where  $y = 1.3 \text{ in.}$ , and  $a = y + t = 1.3 + 3 = 4.3 \text{ in.}$ , as calculated earlier.

### 3.16 DIMENSIONS OF ISOLATED T-SHAPED SECTIONS

In some cases, isolated beams with the shape of a T-section are used in which additional compression area is provided to increase the compression force capacity of sections. These sections are commonly used as prefabricated units.

The ACI Code, Section 6.3.2.2, specifies the size of isolated T-shaped sections as follows:

1. Flange thickness,  $t$ , shall be equal to or greater than one-half of the width of the web,  $b_w$ .
2. Total flange width  $b$  shall be equal to or less than four times the width of the web,  $b_w$  (Fig. 3.35).

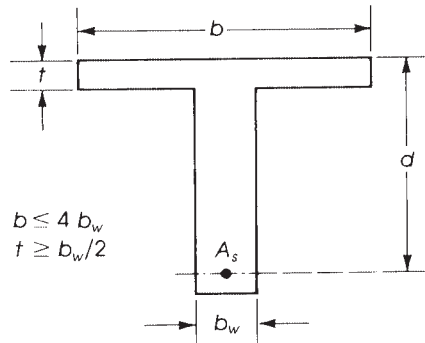


Figure 3.35 Isolated T-shaped sections.

### 3.17 INVERTED L-SHAPED SECTIONS

In slab-beam girder floors, the end beam is called a *spandrel beam*. This type of floor has part of the slab on one side of the beam and is cast monolithically with the beam. The section is unsymmetrical under vertical loading (Fig. 3.36a). The loads on slab  $S_1$  cause torsional moment uniformly distributed on the spandrel beam  $B_1$ . Design for torsion is explained later. The overhanging flange width  $b - b_w$  of a beam with the flange on one side only is limited by the ACI Code, Section 6.3.2.1, to the smallest of the following:

1.  $b_e = L/12$ .
2.  $b_e = 6t + b_w$ .
3.  $b_e = b$ .

If this is applied to the spandrel beam in Fig. 3.36b, then

1.  $b_e = (20 \times 12)/12 = 20$  in. (controls).
2.  $b_e = 6 \times 6 + 12 = 48$  in.
3.  $b_e = 3.5 \times 12 + 12 = 56$  in.

Therefore, the effective flange width is  $b = 32$  in., and the effective dimensions of the spandrel beam are as shown in Fig. 3.36d.

### 3.18 SECTIONS OF OTHER SHAPES

Sometimes a section different from the previously defined sections is needed for special requirements of structural members. For instance, sections such as those shown in Fig. 3.37 might be used in the precast concrete industry. The analysis of such sections is similar to that of a rectangular section, taking into consideration the area of the removed or added concrete. The next example explains the analysis of such sections.

---

#### Example 3.13

The section shown in Fig. 3.38 represents a beam in a structure containing prefabricated elements. The total width and total depth are limited to 14 and 21 in., respectively. Tension reinforcement used is four no. 9 bars. Using  $f'_c = 4$  ksi and  $f_y = 60$  ksi, determine the design moment strength of the section.

#### Solution

1. Determine the position of the neutral axis based on  $T = 4 \times 60 = 240$  K:

$$240 = 0.85f'_c[2(4 \times 5) + 14(a - 4)]$$

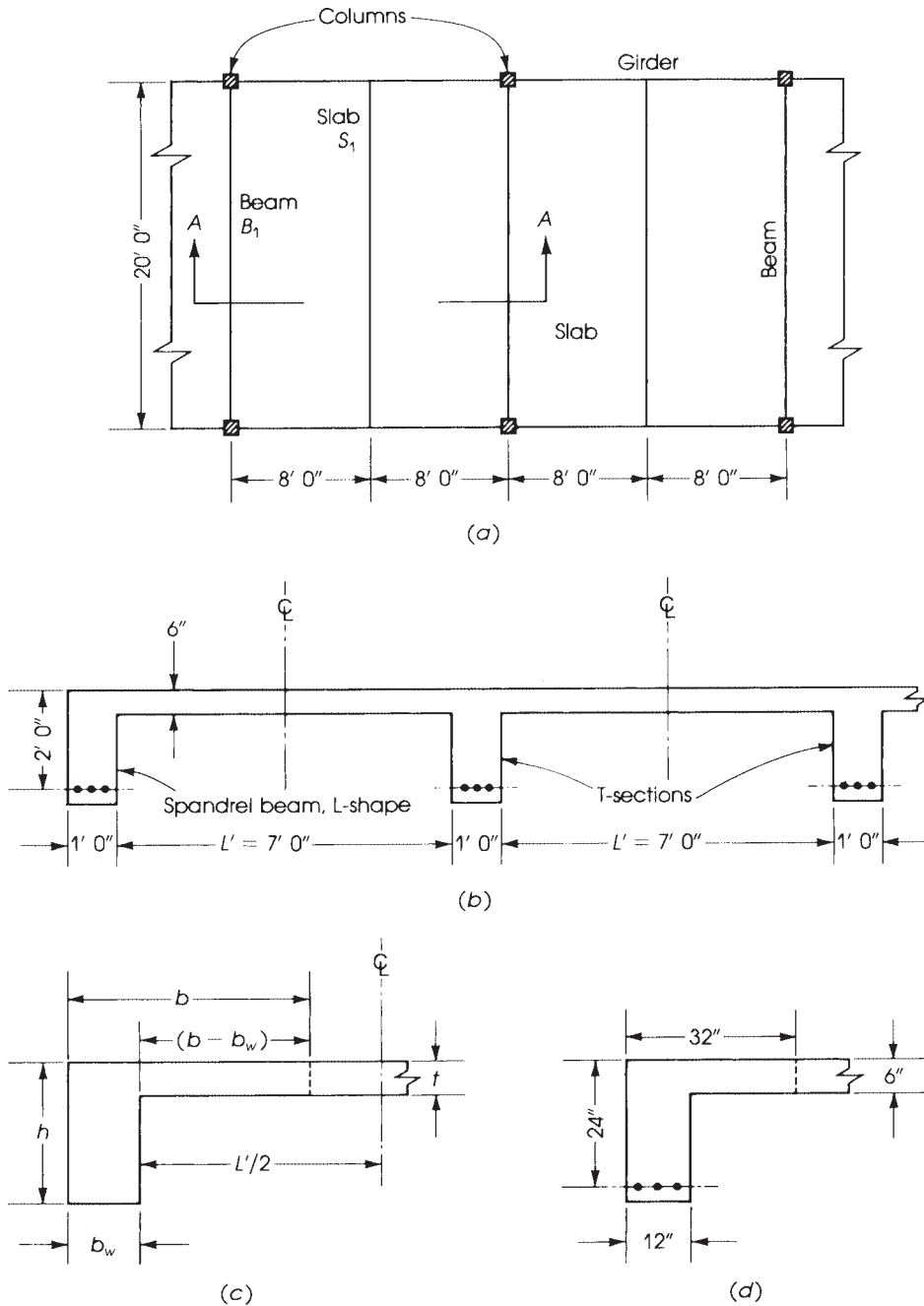
where  $a$  is the depth of the equivalent compressive block needed to produce a total compressive force of 240 K.

If  $240 = (0.85 \times 4)(40 + 14a - 56)$ , then  $a = 6.18$  in. and  $c = a/0.85 = 7.28$  in.

2. Calculate  $M_n$  by taking moments of the two parts of the compressive forces (each by its arm), about the tension steel:

$$\begin{aligned} C'_1 &= \text{compressive force on the two small areas, } 4 \times 5 \text{ in.} \\ &= 0.85 \times 4(2 \times 4 \times 5) = 136 \text{ K} \end{aligned}$$

$$C''_1 = \text{compressive force on area, } 14 \times 2.185$$



**Figure 3.36** Slab-beam-girder floor, showing (a) plan, (b) section including spandrel beam, (c) dimensions of the spandrel beam, and (d) its effective flange width.

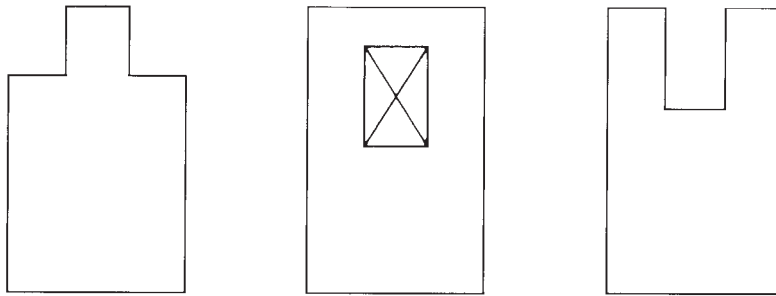


Figure 3.37 Sections of other shapes.

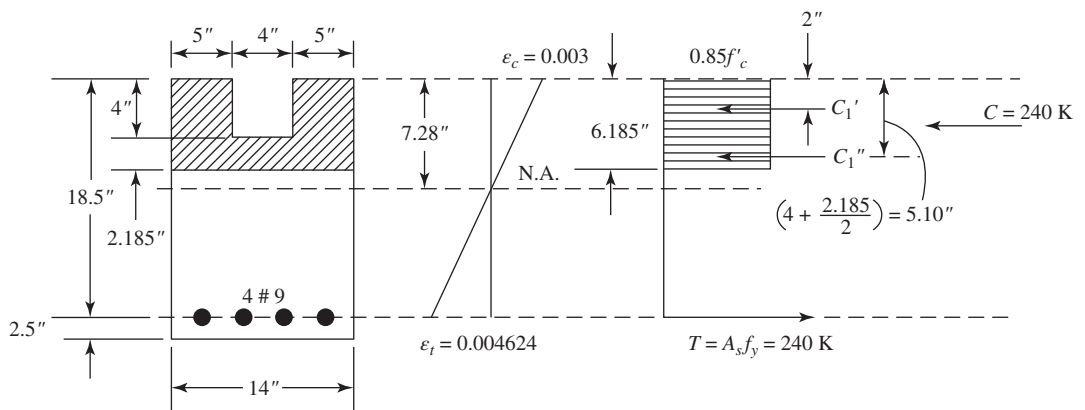


Figure 3.38 Example 3.13: (a) balanced and (b) underreinforced sections.

$$= 0.85 \times 4 \times 14 \times 2.185 = 104 \text{ K}$$

$$M_n = C'_1(d - 2) + C''_1(d - 5.10)$$

$$= 136 \times 16.5 + 104 \times 13.4 = 3637.6 \text{ K} \cdot \text{in.} = 303.1 \text{ K} \cdot \text{ft}$$

3. Calculate  $\phi M_n \epsilon_t = 0.003(d_t - c)/c$ , where  $d_t = 18.5$  in.:

$$\epsilon_t = 0.003(18.5 - 7.28)/7.28 = 0.004624 < 0.005 \text{ but } > 0.004$$

Since  $0.004 < \epsilon_t < 0.005$  the section is in the transition region and  $\phi < 0.9$ :

$$\phi = 0.48 + 83\epsilon_t = 0.864$$

$$\phi M_n = 0.864(303.1) = 261.9 \text{ K} \cdot \text{ft}$$

### 3.19 ANALYSIS OF SECTIONS USING TABLES

Reinforced concrete sections can be analyzed and designed using tables shown in Appendix A (for U.S. customary units) and Appendix B (for SI units). The tables give the value of  $R_u$  as related to

the steel ratio,  $\rho$ , in addition to the maximum and minimum values for  $\rho$  and  $R_u$ . When the section dimensions are known,  $R_u$  is calculated; then  $\rho$  and  $A_s$  are determined from tables. The values in the tables are calculated based on tension-controlled sections with  $\phi = 0.9$ . If  $\phi$  is less than 0.9 (transition region), the values of  $R_u$  should be multiplied by the ratio  $\phi/0.9$ .

$$\phi M_n = R_u b d^2 \quad R_u = \frac{M_u}{b d^2} = \phi \rho f_y \left( 1 - \frac{\rho f_y}{1.7 f'_c} \right)$$

$$A_s = \rho b d \quad \text{and} \quad \rho = \frac{A_s}{b d}$$

For any given value of  $\rho$ ,  $R_u$  can be determined from tables. Then  $\phi M_n$  can be calculated. The values of  $\rho$  and  $R_u$  range between a minimum value of  $R_u$  (min) when  $\rho$  minimum is used to a maximum value as limited by the ACI Code, when  $\rho$  is equal to  $\rho$  (max), for tension controlled sections with  $\phi = 0.9$ .

The use of tables will reduce the manual calculation time. The next example explains the use of tables.

### Example 3.14

Calculate the design moment strength of the section shown in Example 3.2, Fig. 3.14, using tables. Use  $b = 12$  in.,  $d = 21$  in.,  $f'_c = 3$  ksi,  $f_y = 60$  ksi, and three no. 9 bars.

#### Solution

- Using three no. 9 bars,  $A_s = 3.0$  in.<sup>2</sup>,  $\rho = A_s/bd = 3.0/(12 \times 21) = 0.0119$ . From Table 3.2,  $\rho_{\max} = 0.01356 > \rho$  used. Therefore,  $\phi = 0.9$ , and it is a tension-controlled section. From Table A1, for  $\rho = 0.0119$ ,  $R_u = 3$  ksi and  $f_y = 60$  ksi, get  $R_u = 553$  psi (by interpolation).
- Calculate  $\phi M_n = R_u b d^2 = 0.553 (12)(21)^2 = 2926$  K·in. = 243.8 K·ft.

## 3.20 ADDITIONAL EXAMPLES

The following examples are introduced to enhance the understanding of the analysis and design applications.

### Example 3.15

Calculate the design moment strength of the precast concrete section shown in Fig. 3.39 using  $f'_c = 4$  ksi and  $f_y = 60$  ksi.

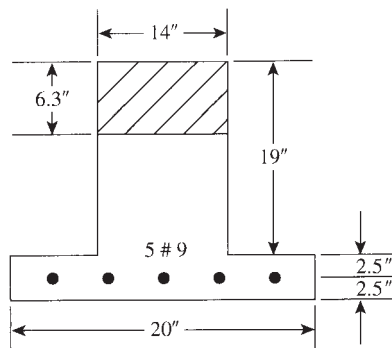


Figure 3.39 Example 3.15.



**Solution**

1. The section behaves as a rectangular section with  $b = 14$  in. and  $d = 21.5$  in. Note that the width  $b$  is that of the section on the compression side.
2. Check that  $\rho = A_s/bd = 5/(14 \times 21.5) = 0.01661$ , which is less than the maximum steel ratio of 0.018 for tension-controlled sections. Therefore,  $\phi = 0.9$ . Also  $\rho > \rho_{\min} = 0.00333$ . Therefore,  $\rho$  is within the limits of a tension-controlled section.
3. Calculate  $a$ :  $a = A_s f_y / (0.85 f'_c b) = 5 \times 60 / (0.85 \times 4 \times 14) = 6.3$  in.

$$\phi M_n = \phi A_s f_y \left( d - \frac{a}{2} \right) = 0.9 \times 5 \times 60 \left( 21.5 - \frac{6.3}{2} \right) = 4954.5 \text{ K} \cdot \text{in} = 412.9 \text{ K} \cdot \text{ft}$$

**Example 3.16**

A reinforced concrete beam was tested to failure and had a rectangular section,  $b = 14$  in. and  $d = 18.5$  in. At failure moment, the strain in the tension steel was recorded and was equal to 0.004106. The strain in the concrete at failure may be assumed to be 0.003. If  $f'_c = 3$  ksi and  $f_y = 60$  ksi, it is required to:

1. Check if the tension steel has yielded.
2. Calculate the steel area provided in the section to develop the above strains. Then calculate the applied moment.
3. Calculate the design moment strength based on the ACI Code provisions. (Refer to Fig. 3.40.)

**Solution**

1. Check the strain in the tension steel relative to the yield strain. The yield strain  $\epsilon_y = f_y/E_s = 60/29,000 = 0.00207$ . The measured strain in the tension steel is equal to 0.004106, which is much greater than 0.00207, indicating that the steel bars have yielded and in the elastoplastic range. The concrete strain was 0.003, indicating that the concrete has failed and started to crush. Therefore, the tension steel has yielded.
2. Calculate the depth of the neutral axis  $c$  from the strain diagram (Fig. 3.40). From the triangles of the strain diagram,

$$\frac{c}{d} = \frac{0.003}{0.003 + 0.004106} \quad \text{and} \quad c = 18.5 \left( \frac{3}{7.106} \right) = 7.81 \text{ in.}$$

$$a = \beta_1 c = 0.85 \times 7.81 = 6.64 \text{ in.}$$

The compression force in the concrete,  $C_c = 0.85$ ,

$$f'_c a b = 0.85 \times 3 \times 6.64 \times 14 = 237 \text{ K}$$

The tension steel  $A_s = C_c/f_y = 237/60 = 3.95 \text{ in.}^2$  (section has five no. 8 bars):

$$M_n = A_s f_y \left( d - \frac{a}{2} \right) = 3.95 \times 60 \left( 18.5 - \frac{6.64}{2} \right) = 3597.6 \text{ K} \cdot \text{in} = 299.8 \text{ K} \cdot \text{ft}$$

3. Check  $\epsilon_t = 0.003(d_t - c)/c$ .

$$c = 7.81 \text{ in.} \quad d_t = h - 2.5 \text{ in.} = 22 - 2.5 = 19.5 \text{ in.}$$

Therefore,  $\epsilon_t = 0.003(19.5 - 7.81)/7.81 = 0.0045$ , which is less than 0.005 for tension-controlled sections but greater than 0.004. Section is in the transition region, and  $\phi < 0.9$ :

$$\phi = 0.48 + 83\epsilon_t = 0.853$$

The allowable design moment =  $\phi M_n = 0.863 \times 299.8 = 255.6 \text{ K} \cdot \text{ft}$ .

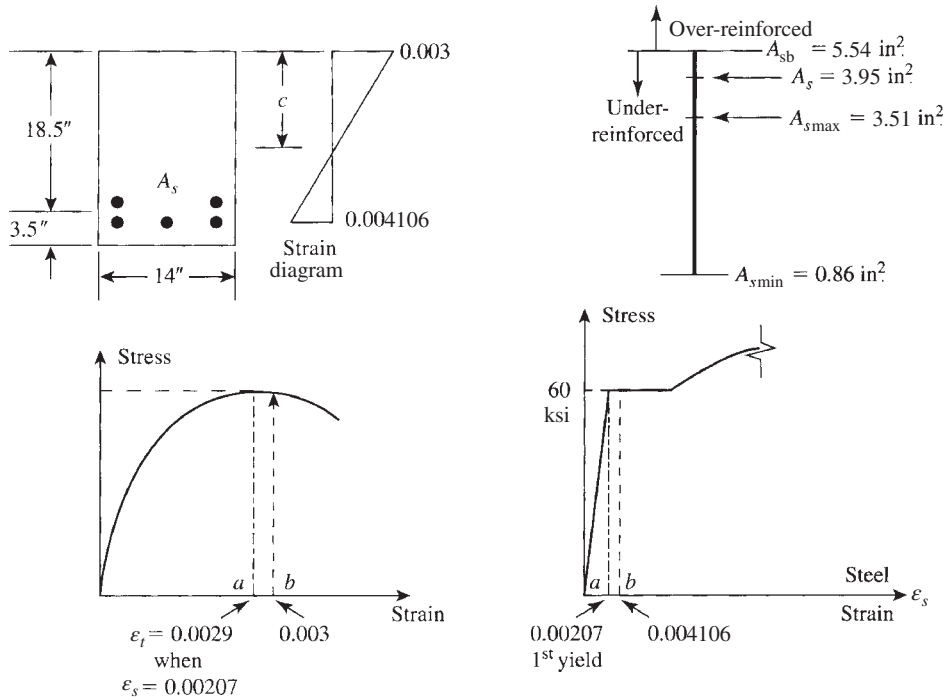


Figure 3.40 Example 3.16.

### Discussion

From Table 3.2,  $\rho_b = 0.0214$  and  $\rho_{\max} = 0.01356$ . For comparison,  $A_s$  (max) =  $0.01356(14 \times 18.5) = 3.51 \text{ in.}^2$  for  $\phi = 0.9$ , and  $A_s$  (balanced) =  $5.54 \text{ in.}^2$ . The ratio of  $A_s/A_{s,\max} = 3.95/3.51 = 1.125$  and  $A_s/A_{sb} = 0.713$ . If  $A_s = A_{\max} = 3.51 \text{ in.}^2$  is used with  $\phi = 0.9$ , then

$$a = 3.51 \times \frac{60}{0.85 \times 3 \times 14} = 5.9 \text{ in.}$$

and

$$\phi M_n = 0.9 \times 3.51 \times 60 \left( 18.5 - \frac{5.9}{2} \right) = 2947.2 \text{ K} \cdot \text{in.} = 245.6 \text{ K} \cdot \text{ft}$$

which is equal to 96% of the moment calculated above. Figure 3.40 shows the behavior of the tested beam.

## 3.21 EXAMPLES USING SI UNITS

The following equations are some of those mentioned in this chapter but converted to SI units. The other equations, which are not listed here, can be used for both U.S. Customary and SI units. Note that  $f'_c$  and  $f_y$  are in MPa ( $\text{N/mm}^2$ ):

$$\rho_b = 0.85\beta_1 \left( \frac{f'_c}{f_y} \right) \left( \frac{600}{600 + f_y} \right)$$

For tension-controlled condition,

$$\rho_{\max} = \frac{(0.003 + f_y/E_s)\rho_b}{0.008}$$

$$\rho - \rho' \geq 0.85\beta_1 \left(\frac{f'_c}{f_y}\right) \left(\frac{d'}{d}\right) \left(\frac{600}{600 - f_y}\right) = K$$

### Example 3.17

Determine the design moment strength and the position of the neutral axis of a rectangular section that has  $b = 300$  mm,  $d = 500$  mm, and is reinforced with five 20-mm-diameter bars. Given  $f'_c = 20$  MPa and  $f_y = 400$  MPa.

#### Solution

1. Area of five 20-mm bars is 1570 mm<sup>2</sup>:

$$\rho = \frac{A_s}{bd} = \frac{1570}{300 \times 500} = 0.01047 \quad \rho_{\min} = \frac{1.4}{f_y} = 0.0035$$

For  $f'_c = 20$  MPa and  $f_y = 400$  MPa,  $\rho_b = 0.0217$  and  $\rho_{\max} = 0.01356$ . Note that  $E_s = 200,000$  MPa and  $f_y/E_s = 0.002$ . Because  $\rho < \rho_{\max}$ , it is a tension-controlled section with  $\phi = 0.9$ . Also  $\rho > \rho_{\min}$ .

2. Calculate the design moment strength:

$$\phi M_n = \phi A_s f_y \left(d - \frac{1}{2}a\right)$$

$$a = \frac{A_s f_y}{0.85 f'_c b} = 1570 \times \frac{400}{0.85 \times 20 \times 300} = 123 \text{ mm}$$

$$\phi M_n = 0.9 \times 1570 \times 400 \left(500 - \frac{123}{2}\right) \times 10^{-6} = 247.8 \text{ KN} \cdot \text{m}$$

Note that the moment was multiplied by  $10^{-6}$  to get the answer in KN·m. The distance to the neutral axis from the compression fibers ( $c$ ) =  $a/\beta_1$ , where  $\beta_1 = 0.85$  for  $f'_c = 30$  MPa. Therefore,  $c = 123/0.85 = 145$  mm.

### Example 3.18

A 2.4-m-span cantilever beam has a rectangular section with  $b = 300$  mm,  $d = 490$  mm, and is reinforced with three bars, 25 mm in diameter. The beam carries a uniform dead load (including its own weight) of 25.5 kN/m and a uniform live load of 32 kN/m. Check the adequacy of the section if  $f'_c = 30$  MPa and  $f_y = 400$  MPa.

#### Solution

1.  $U = 1.2D + 1.6L = 1.2 \times 25.5 + 1.6 \times 32 = 81.8$  kN/m. External factored moment =  $M_u = UL^2/2 = 81.8(2.4^2)/2 = 235.6$  KN·m.
2. Calculate the design moment strength:

$$A_s = 1470 \text{ mm}^2 \quad \rho = \frac{A_s}{bd} = \frac{1470}{300 \times 490} = 0.01$$

$$\rho_b = 0.85\beta_1 \left( \frac{f'_c}{f_y} \right) \left( \frac{600}{600 + f_y} \right) = 0.0325$$

$$\rho_{\max} = \left( \frac{0.005}{0.008} \right) \rho_b = \left( \frac{5}{8} \right) (0.0325) = 0.0203 \quad \rho_{\min} = \frac{1.4}{400} = 0.0035$$

Since  $\rho < \rho_{\max}$  but  $> \rho_{\min}$ , it is a tension-controlled section and  $\phi = 0.9$ . Let  $a = A_s f_y / (0.85 f'_c b) = 1470 \times 400 / (0.85 \times 30 \times 300) = 77$  mm,  $c = 90$  mm. Also  $\phi M_n = \phi A_s f_y (d - a/2) = 0.9 \times 1470 \times 400 (490 - 77/2) \times 10^{-6} = 238.9$  KN·m. Also  $\epsilon_t = 0.003(d_t - c)/c = 0.003(490 - 90)/90 = 0.01333 > 0.005$ ,  $\phi = 0.9$  as assumed.

3. The internal design moment strength is greater than the external factored moment. Therefore, the section is adequate.

### Example 3.19

Calculate the design moment strength of a rectangular section with the following details:  $b = 250$  mm,  $d = 440$  mm,  $d' = 60$  mm, tension steel is six bars 25 mm in diameter (in two rows), compression steel is three bars 20 mm in diameter,  $f'_c = 20$  MPa, and  $f_y = 350$  MPa.

### Solution

1. Check if compression steel yields:

$$A_s = 490 \times 6 = 2940 \text{ mm}^2 \quad A'_s = 314 \times 3 = 942 \text{ mm}^2 \quad A_s - A'_s = 1998 \text{ mm}^2$$

$$\rho = \frac{2940}{250 \times 440} = 0.0267 \quad \rho' = \frac{942}{250 \times 440} = 0.00856$$

$$\rho - \rho' = 0.01814$$

For compression steel to yield:

$$\rho - \rho' \geq 0.85 \times 0.85 \times \left( \frac{20}{350} \right) \left( \frac{60}{440} \right) \left( \frac{600}{600} - 350 \right) = 0.01351$$

$$\rho - \rho' = 0.01814 > 0.01351.$$

Therefore, compression steel yields.

2. Calculate  $M_n$ :

$$a = \frac{A_s - A'_s}{0.85 f'_c b} = \frac{1998}{0.85 \times 20 \times 250} = 164 \text{ mm}$$

$$M_n = \left[ 1998 \times 350 \left( 440 - \frac{164}{2} \right) + 942 \times 350 (440 - 60) \right] \times 10^{-6} = 417.3 \text{ KN} \cdot \text{m}$$

3. Check  $\phi$  based on  $\epsilon_t \geq 0.005$ .

$$\epsilon_t = \frac{0.003(d_t - c)}{c} \quad a = 164 \text{ mm} \quad c = \frac{164}{0.85} = 193 \text{ mm}$$

$$d_t = h - 65 \text{ mm} = d + 25 \text{ mm} \quad \text{for two rows of tension bars}$$

$$d_t = 440 + 25 = 465 \text{ mm}$$

Let  $\epsilon_t = 0.003(465 - 193)/193 = 0.04228$ , which is less than 0.005, but greater than the 0.004 limit. Also  $\phi = 0.48 + 83 \times \epsilon_t = 0.831$ , and  $\phi M_n = 0.831(417.3) = 346.8$  KN·m.

**SUMMARY**

Flowcharts for the analysis of sections are given at [www.wiley.com/college/hassoun](http://www.wiley.com/college/hassoun).

**Sections 3.1–3.8**

1. The type of failure in a reinforced concrete flexural member is based on the amount of tension steel used,  $A_s$ .
2. Load factors for dead and live loads are  $U = 1.2D + 1.6L$ . Other values are given in the text.
3. The reduction strength factor for beams  $\phi = 0.9$  for tension-controlled sections with  $\epsilon_t \geq 0.005$ .
4. An equivalent rectangular stress block can be assumed to calculate the design moment strength of the beam section,  $\phi M_n$ .
5. Design provisions are based on four conditions, Section 3.5.

**Sections 3.9–3.13: Analysis of a Singly Reinforced Rectangular Section**

Given:  $f'_c, f_y, b, d$ , and  $A_s$ . Required: the design moment strength,  $\phi M_n$ .

To determine the design moment strength of a singly reinforced concrete rectangular section:

1. Calculate the compressive force,  $C = 0.85f'_c ab$  and the tensile force,  $T = A_s f_y$ . Calculate  $a = A_s f_y / (0.85f'_c b)$ .
2. Calculate  $\phi M_n = \phi C(d - a/2) = \phi T(d - a/2) = \phi A_s f_y (d - a/2)$ . Check  $\epsilon_t = 0.003(d_t - c)/c \geq 0.005$  for  $\phi = 0.9$  (tension-controlled section). (See Section 3.6.)
3. Calculate the balanced, maximum, and minimum steel ratios:

$$\rho_b = 0.85\beta_1 \left( \frac{f'_c}{f_y} \right) \left( \frac{87}{87 + f_y} \right) \quad \rho_{\max} = \frac{(0.003 + f_y/E_s)\rho_b}{0.008}$$

$$\rho_{\min} = \frac{0.2}{f_y} \quad \text{for } f'_c \leq 4.5 \text{ ksi}$$

where  $f'_c$  and  $f_y$  are in ksi. (See Section 3.9.2.) The steel ratio in the section is  $\rho = A_s/bd$ . Check that  $\rho_{\min} \leq \rho \leq \rho_{\max}$ .

4. Another form of the design moment strength is

$$M_n = \rho f_y (bd^2) \left( 1 - \frac{\rho f_y}{1.7f'_c} \right) = R_n bd^2$$

$$R_n = \rho f_y \left[ 1 - \left( \frac{\rho f_y}{1.7f'_c} \right) \right] \quad \text{and} \quad R_u = \phi R_n$$

5. For  $f_y = 60$  ksi and  $f'_c = 3$  ksi (Table 3.2),  $\rho_{\max} = 0.01356$ ,  $\rho_{\min} = 0.00333$ ,  $R_n = 686$  psi, and  $R_u = 615$  psi.  
For  $f_y = 60$  ksi and  $f'_c = 4$  ksi,  $\rho_{\max} = 0.01806$ ,  $\rho_{\min} = 0.00333$ ,  $R_n = 911$  psi, and  $R_u = 820$  psi.

**Section 3.14: Analysis of Rectangular Section with Compression Steel**

Given:  $b, d, d', A_s, f'_c$ , and  $f_y$ . Required: the design moment strength,  $\phi M_n$ .

1. Calculate  $\rho = A_s/bd$ ,  $\rho' = A_s'/bd$ , and  $(\rho - \rho')$ .
2. Calculate  $\rho_b$ ,  $\rho_{\max}$ , and  $\rho_{\min}$  as given above (or see Section 3.10).
3. Calculate  $K = 0.85\beta_1(f'_c/f_y)(d'/d)[87/(87 - f_y)]$ . ( $f'_c$  and  $f_y$  are in ksi.)
4. When compression steel yields,
  - a. Check that  $\rho \geq \rho_{\min}$ .
  - b. Check that  $\rho - \rho' \geq K$  for compression steel to yield. If not, then compression steel does not yield.
  - c. If compression steel yields, then  $f'_s = f_y$ .
  - d. Check that  $\rho \leq (\rho_{\max} + \rho')$  or  $(\rho - \rho') \leq \rho_{\max}$ .
  - e.  $a = (A_s - A'_s)f_y / (0.85f'_c b)$ .
  - f. Calculate  $\phi M_n = \phi(A_s - A'_s)f_y \left(d - \frac{1}{2}a\right) + \phi A'_s f_y (d - d')$ .
  - g. If  $\rho - \rho' > \rho_{\max}$  but  $< \rho_{\max t}$  (for the transition region), then  $\phi < 0.9$  for  $M_{u1}$  and  $\phi = 0.9$  for  $M_{u2}$  (Eq. 3.44a).
5. When compression steel does not yield,
  - a. Compression steel does not yield when  $\rho - \rho' < K$ . The value of  $f'_s$  is not known.
  - b. Calculate  $c =$  distance to the neutral axis from the compression fibers as follows:

$$A_1 c^2 + A_2 c + A_3 = 0$$

where

$$A_1 = 0.85f'_c \beta_1 b$$

$$A_2 = A'_s(87 - 0.85f'_c) - A_s f_y$$

$$A_3 = -87A'_s d'$$

Solve for  $c$ . An alternative solution to calculate  $c$  is as follows:

$$C + C' = T$$

$$C = 0.85f'_c(\beta_1 c b - A'_s) \quad C' = A'_s \left( \frac{87(c - d')}{c} \right) - 0.85f'_c A'_s$$

and

$$T = A_s f_y$$

Solve for  $c$ .

- c. Calculate  $f'_s = 87(c - d')/c \leq f_y$  (in ksi).
- d. Check that  $\rho \leq [\rho_{\max} + \rho'(f'_s/f_y)]$  or

$$A_s \leq \rho_{\max}(bd) + A'_s \left( \frac{f'_s}{f_y} \right).$$

- e. Calculate  $a$ :

$$a = \frac{A_s f_y - A'_s f'_s}{0.85f'_c b} \quad \text{or} \quad a = \beta_1 c$$

- f. Calculate  $\phi M_n$ :

$$\phi M_n = \phi \left[ (A_s f_y - A'_s f'_s) \left( d - \frac{1}{2}a \right) + A'_s f'_s (d - d') \right]$$

Note that  $(A_s f_y - A'_s f_y) = A_{s1} = A_s - A_{s2} = A_s - (A'_s f'_s / f_y)$  and  $A_{s2} f_y = A'_s f'_s$ . Also,  $a = A_{s1} f_y / (0.85 f'_c b)$ .

### Sections 3.15–3.17: Analysis of T-Sections

Given:  $f'_c, f_y, A_s$ , and section dimensions. Required: design moment strength,  $\phi M_n$ . Two possible cases may develop. (Determine the effective flange width,  $b_e$ , first.)

#### Case 1

1. If  $a \leq t$  (the slab thickness), then it is a T-section shape but acts as a singly reinforced rectangular section using  $b = b_e$  (the flange effective width) to calculate  $\phi M_n$ .

$$a' = \frac{A_s f_y}{0.85 f'_c b_e} \leq t$$

Or, check that  $A_c$  (the area of concrete in compression)  $= A_s f_y / (0.85 f'_c) \leq b t$ . If  $A_c \geq b t$ , then it is a T-section analysis.

2. If  $a' \leq t$  or  $A_c \leq b t$ , then  $a' = a$  and  $\phi M_n = \phi A_s f_y (d - a/2)$ .
3. Check that  $\rho_w$  (steel ratio in web)  $= A_s / b_w d \geq \rho_{\min}$ .
4. Check that  $A_s \leq \text{Max } A_s$  from Eq. 3.71. (Normally, this is OK for this case.)

$$\text{Max } A_s = \left( \frac{0.85 f'_c}{f_y} \right) [(b_e - b_w) t + 0.375 \beta_1 b_w d]$$

5. Check that  $\epsilon_t \geq 0.005$  for  $\phi = 0.9$ . (Normally this is OK for this case.)
6. The effective flange width  $b = b_e$  is the smallest of
  - a. Span/4
  - b. Center to center of adjacent slabs
  - c.  $b_w + 16 t$ , where  $t$  = slab thickness

#### Case 2

1. When  $a > t$  or  $A_c > b t$ , it is a T-section analysis.
2. For the flange,  $C_f = 0.85 f'_c t (b - b_w) = A_{sf} f_y$ , calculate  $A_{sf} = C_f / f_y$ .
3. For the web,

$$A_{sw} = \text{tension steel in the web} = A_s - A_{sf}$$

$$a = \frac{(A_s - A_{sf}) f_y}{0.85 f'_c b_w}$$

$$C_w(\text{web}) = 0.85 f'_c a b_w = A_{sw} f_y$$

4. 
$$\begin{aligned} \phi M_n &= \phi [M_w(\text{web}) + M_f(\text{flange})] = \phi \left[ C_w \left( d - \frac{1}{2} a \right) + C_f \left( d - \frac{1}{2} t \right) \right] \\ &= \phi \left[ 0.85 f'_c a b_w \left( d - \frac{1}{2} a \right) + 0.85 f'_c t (b - b_w) \left( d - \frac{1}{2} t \right) \right] \\ &= \phi \left[ (A_s - A_{sf}) f_y \left( d - \frac{1}{2} a \right) + A_{sf} f_y \left( d - \frac{1}{2} t \right) \right] \end{aligned}$$

5. Check that  $\epsilon_t \geq 0.005$  for tension-controlled section and  $\phi = 0.9$ . (See Example 3.12.)
6. Check that  $A_s, \min \leq A_s \leq A_s, \max$ . (See case 1.)

### Sections 3.18–3.21

1. Analysis of nonuniform sections is explained in Example 3.13.
2. Tables in Appendix A may be used for the analysis of rectangular sections.
3. Examples in SI units are introduced.

## REFERENCES

1. E. Hognestad, N. W. Hanson, and D. McHenry. "Concrete Distribution in Ultimate Strength Design." *ACI Journal* 52 (December 1955): 455–479.
2. A. H. Mattock, L. B. Kriz, and E. Hognestad. "Rectangular Concrete Stress Distribution in Ultimate Strength Design." *ACI Journal* (February 1961): 875–929.
3. J. R. Janney, E. Hognestad, and D. McHenry. "Ultimate Flexural Strength of Prestressed and Conventionally Reinforced Concrete Beams." *ACI Journal* (February 1956): 601–620.
4. A. H. Mattock and L. B. Kriz. "Ultimate Strength of Nonrectangular Structural Concrete Members." *ACI Journal* 57 (January 1961): 737–766.
5. American Concrete Institute (ACI). *Building Code Requirements for Structural Concrete*. ACI Code 318-14. ACI, Detroit, MI, 2014.
6. UNESCO. *Reinforced Concrete, An International Manual*. Butterworth, London, 1971.
7. M. N. Hassoun. "Ultimate-Load Design of Reinforced Concrete," *In View Point Publication*, Cement and Concrete Association, London, 1981.
8. ASCE 7-10, *Minimum Design Loads for Buildings and Other Structures*. American Society of Civil Engineering, (ASCE), Reston, VA, 2010.

## PROBLEMS

- 3.1 Singly reinforced rectangular sections.** Determine the design moment strength of the sections given in the following table, knowing that  $f'_c = 4$  ksi and  $f_y = 60$  ksi. (Answers are given in the right column.)

No.	$b$ (in.)	$d$ (in.)	$A_s$ (in. <sup>2</sup> )	$\phi M_n$ (K·ft)
a	14	22.5	5.08 (4 no. 10)	441.2
b	18	28.5	7.62 (6 no. 10)	849.1
c	12	23.5	4.00 (4 no. 9)	370.1
d	12	18.5	3.16 (4 no. 8)	230.0
e	16	24.5	6.35 (5 no. 10)	600.0
f	14	26.5	5.00 (5 no. 9)	525.3
g	10	17.5	3.00 (3 no. 9)	200.5
h	20	31.5	4.00 (4 no. 9)	535.2

For problems in SI units, 1 in. = 25.4 mm, 1 in.<sup>2</sup> = 645 mm<sup>2</sup>,  
1 ksi = 6.9 MPa (N/mm<sup>2</sup>), and 1  $M_u$  (K·ft) = 1.356 kN·m.



**3.2** Rectangular section with compression steel. Determine the design moment strength of the sections given in the following table, knowing that  $f'_c = 4$  ksi,  $f_y = 60$  ksi, and  $d' = 2.5$  in. (Answers are given in the right column. In the first four problems,  $f'_s = f_y$ )

No.	$b$ (in.)	$d$ (in.)	$A_s$ (in. <sup>2</sup> )	$A'_s$ (in. <sup>2</sup> )	$\phi M_n$ (K·ft)
a	15	22.5	8.00 (8 no. 9)	2.00 (2 no. 9)	692.2
b	17	24.5	10.08 (8 no. 10)	2.54 (2 no. 10)	950.0
c	13	22	7.00 (7 no. 9)	1.80 (3 no. 7)	590.2
d	10	21.5	5.08 (4 no. 10)	1.20 (2 no. 7)	418.2
e	14	20.5	7.62 (6 no. 10)	2.54 (2 no. 10)	597.9
f	16	20.5	9.00 (9 no. 9)	4.00 (4 no. 9)	716.3
g	20	18.0	12.00 (12 no. 9)	6.00 (6 no. 9)	820.3
h	18	20.5	10.16 (8 no. 10)	5.08 (4 no. 10)	813.7

For problems in SI units: 1 in. = 25.4 mm, 1 in.<sup>2</sup> = 645 mm<sup>2</sup>, 1 ksi = 6.9 MPa (N/mm<sup>2</sup>), and 1  $M_u$  (K·ft) = 1.356 kN·m.

**3.3 T-sections.** Determine the design moment strength of the T-sections given in the following table, knowing that  $f'_c = 3$  ksi and  $f_y = 60$  ksi. (Answers are given in the right column. In the first three problems,  $a < t$ .)

No.	$b$ (in.)	$b_w$ (in.)	$t$ (in.)	$d$ (in.)	$A_s$ (in. <sup>2</sup> )	$\phi M_n$ (K·ft)
a	54	14	3	17.5	5.08 (4 no. 10)	374.8
b	48	14	4	16.5	4.0 (4 no. 9)	279.4
c	72	16	4	18.5	10.16 (8 no. 10)	769.9
d	32	16	3	15.5	6.0 (6 no. 9)	N.G.
e	44	12	4	20.5	8.0 (8 no. 9)	660.1
f	50	14	3	16.5	7.0 (7 no. 9)	466.8
g	40	16	3	16.5	6.35 (5 no. 10)	415.0
h	42	12	3	17.5	6.0 (6 no. 9)	425.8

For problems in SI units: 1 in. = 25.4 mm, 1 in.<sup>2</sup> = 645 mm<sup>2</sup>, 1 ksi = 6.9 MPa (N/mm<sup>2</sup>), and 1  $M_u$  (K·ft) = 1.356 kN·m. Answer = 325.5 K·ft if  $\rho_{max}$  is used.

**3.4** Calculate  $\rho_b$ ,  $\rho_{max}$ ,  $R_u(\max)$ ,  $R_u$ ,  $a/d$ , and  $\max(a/d)$  for a rectangular section that has a width of  $b = 12$  in. (300 mm) and an effective depth of  $d = 20$  in. (500 mm) for the following cases:

- a.  $f'_c = 3$  ksi,  $f_y = 40$  ksi,  $A_s =$  four no. 8 bars
- b.  $f'_c = 4$  ksi,  $f_y = 60$  ksi,  $A_s =$  four no. 7 bars
- c.  $f'_c = 4$  ksi,  $f_y = 75$  ksi,  $A_s =$  four no. 9 bars
- d.  $f'_c = 5$  ksi,  $f_y = 60$  ksi,  $A_s =$  four no. 9 bars
- e.  $f'_c = 30$  MPa,  $f_y = 400$  MPa,  $A_s = 3 \times 30$  mm
- f.  $f'_c = 20$  MPa,  $f_y = 300$  MPa,  $A_s = 3 \times 25$  mm
- g.  $f'_c = 30$  MPa,  $f_y = 500$  MPa,  $A_s = 4 \times 25$  mm
- h.  $f'_c = 25$  MPa,  $f_y = 300$  MPa,  $A_s = 4 \times 20$  mm

- 3.5** Using the ACI Code requirements, calculate the design moment strength of a rectangular section that has a width of  $b = 250$  mm (10 in.) and an effective depth of  $d = 550$  mm (22 in.) when  $f'_c = 20$  MPa (3 ksi),  $f_y = 420$  MPa (60 ksi), and the steel used is as follows:
- $4 \times 20$  mm
  - $3 \times 25$  mm
  - $4 \times 30$  mm
  - 2 no. 9 bars
  - 6 no. 9 bars
- 3.6** A reinforced concrete simple beam has a rectangular section with a width of  $b = 8$  in. (200 mm) and effective depth of  $d = 18$  in. (450 mm). At design moment (failure), the strain in the steel was recorded and was equal to 0.0015. (The strain in concrete at failure may be assumed to be 0.003) Use  $f'_c = 3$  ksi (20 MPa) and  $f_y = 50$  ksi (350 MPa) for all parts.
- Check if the section is balanced, tension controlled, or compression controlled.
  - Determine the steel area that will make the section balanced.
  - Calculate the steel area provided in the section to produce the aforementioned strains and then calculate its moment. Compare this value with the design moment strength allowed by the ACI Code using  $\rho_{\max}$ .
  - Calculate the design moment strength of the section if the steel percentage used is  $\rho = 1.4\%$ .
- 3.7** A 10-ft- (3-m)-span cantilever beam has an effective cross section ( $bd$ ) of  $12 \times 24$  in. ( $300 \times 600$  mm) and is reinforced with five no. 8 ( $5 \times 25$  mm) bars. If the uniform load due to its own weight and the dead load are equal to 685 lb/ft (10 kN/m), determine the allowable uniform live load on the beam using the ACI load factors. Given:  $f'_c = 3$  ksi (20 MPa) and  $f_y = 60$  ksi (400 MPa).
- 3.8** The cross section of a 17-ft (5-m)-span simply supported beam is  $10 \times 28$  in. ( $250 \times 700$  mm), and it is reinforced symmetrically with eight no. 6 bars ( $8 \times 20$  mm) in two rows. Determine the allowable concentrated live load at midspan considering the total acting dead load (including self-weight) is equal to 2.55 K/ft (37 kN/m). Given:  $f'_c = 3$  ksi (20 MPa) and  $f_y = 40$  ksi (300 MPa).
- 3.9** Determine the design moment strength of the sections shown in Fig. 3.41. Neglect the lack of symmetry in ( $b$ ). Given:  $f'_c = 4$  ksi (30 MPa) and  $f_y = 60$  ksi (400 MPa).
- 3.10** A rectangular concrete section has a width of  $b = 12$  in. (300 mm), an effective depth of  $d = 18$  in. (450 mm), and  $d' = 2.5$  in. (60 mm). If compression steel consisting of two no. 7 bars ( $2 \times 20$  mm) is used, calculate the allowable moment strength that can be applied on the section if the tensile steel,  $A_s$ , is as follows:
- Four no. 7 ( $4 \times 20$  mm) bars
  - Eight no. 7 ( $8 \times 20$  mm) bars
- Given:  $f'_c = 3$  ksi (20 MPa) and  $f_y = 40$  ksi (300 MPa).
- 3.11** A 16-ft- (4.8-m)-span simply supported beam has a width of  $b = 12$  in. (300 mm),  $d = 22$  in. (500 mm),  $d' = 2.5$  in. (60 mm), and  $A'_s =$  three no. 6 bars ( $3 \times 20$  mm). The beam carries a uniform dead load of 2 K/ft (30 kN/m), including its own weight. Calculate the allowable uniform live load that can be safely applied on the beam. Given:  $f'_c = 4$  ksi (20 MPa) and  $f_y = 60$  ksi (400 MPa). (Hint: Use  $\rho_{\max}$  for the basic section to calculate  $M_u$ .)
- 3.12** Check the adequacy of a 10-ft- (3-m)-span cantilever beam, assuming a concrete strength of  $f'_c = 4$  ksi (30 MPa) and a steel yield strength of  $f_y = 60$  ksi (400 MPa) are used. The dimensions of the beam section are  $b = 10$  in. (250 mm),  $d = 20$  in. (500 mm),  $d' = 2.5$  in. (60 mm),  $A_s =$  six no. 7 bars ( $6 \times 20$  mm),  $A'_s =$  two no. 5 bars ( $2 \times 15$  mm). The dead load on the beam, excluding its own weight, is equal to 2 K/ft (30 kN/m), and the live load equals 1.25 K/ft (20 kN/m). (Compare the internal  $M_u$  with the external factored moment.)
- 3.13** A series of reinforced concrete beams spaced at 9 ft (2.7 m) on centers are acting on a simply supported span of 18 ft (5.4 m). The beam supports a reinforced concrete floor slab 4 in. (100 mm) thick. If the width of the web is  $b_w = 10$  in. (250 mm),  $d = 18$  in. (450 mm), and the beam is reinforced with three no. 9 bars ( $3 \times 30$  mm), determine the moment strength of a typical interior beam. Given:  $f'_c = 4$  ksi (30 MPa) and  $f_y = 60$  ksi (400 MPa).

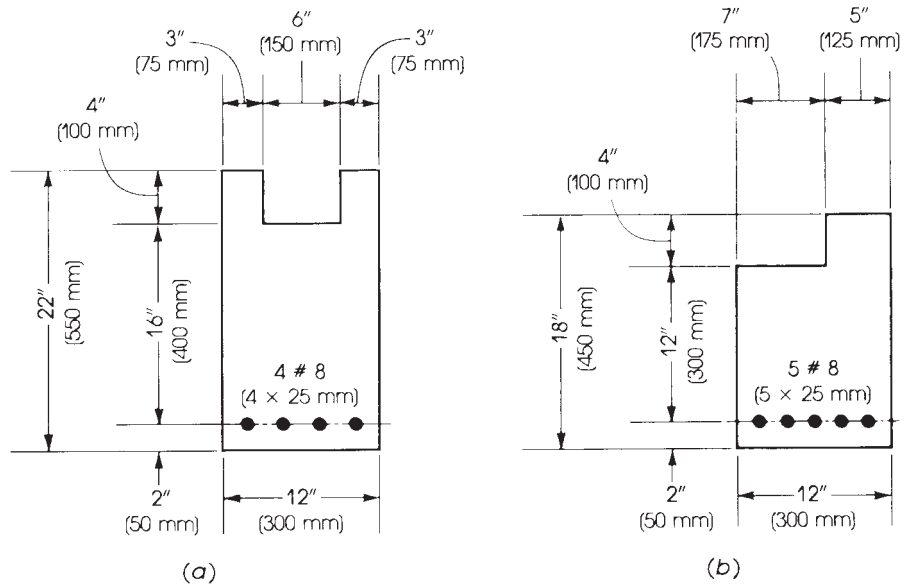


Figure 3.41 Problem 3.9.

**3.14** Calculate the design moment strength of a T-section that has the following dimensions:

- Flange width = 30 in. (750 mm)
- Flange thickness = 3 in. (75 mm)
- Web width = 10 in. (250 mm)
- Effective depth ( $d$ ) = 18 in. (450 mm)
- Tension reinforcement: six no. 8 bars ( $6 \times 25$  mm)
- $f'_c = 3$  ksi (20 MPa)
- $f_y = 60$  ksi (400 MPa)

**3.15** Repeat Problem 3.14 if  $d = 24$  in. (600 mm).

**3.16** Repeat Problem 3.14 if the flange is an inverted L shape with the same flange width projecting from one side only. (Neglect lack of symmetry)

# CHAPTER 4

## FLEXURAL DESIGN OF REINFORCED CONCRETE BEAMS



Reinforced concrete office building, Amman, Jordan.

### 4.1 INTRODUCTION

In the previous chapter, the analysis of different reinforced concrete sections was explained. Details of the section were given, and we had to determine the design moment of the section. In this chapter, the process is reversed: The external moment is given, and we must find safe, economic, and practical dimensions of the concrete section and the area of reinforcing steel that provides adequate internal moment strength.

### 4.2 RECTANGULAR SECTIONS WITH TENSION REINFORCEMENT ONLY

From the analysis of rectangular singly reinforced sections (Section 3.9), the following equations were derived for tension-controlled sections, where  $f'_c$  and  $f_y$  are in ksi:

$$\rho_b = 0.85\beta_1 \frac{f'_c}{f_y} \left( \frac{87}{87 + f_y} \right) \quad (3.18)$$

$$\rho_{\max} = \rho_b \left( \frac{0.003 + f_y/E_s}{0.008} \right) \quad (3.31)$$

For  $f_y = 60$  ksi,

$$\rho_{\max} = 0.63375\rho_b \text{ (or } 0.634\rho_b)$$

Also,

$$\rho_{\max} \begin{cases} 0.5474\rho_b & \text{for } f_y = 40 \text{ ksi} \\ 0.5905\rho_b & \text{for } f_y = 50 \text{ ksi} \\ 0.6983\rho_b & \text{for } f_y = 75 \text{ ksi} \end{cases}$$

**Table 4.1** Suggested Design Steel Ratios,  $\rho_s$ 

$f'_c$ (ksi)	$f_y$ (ksi)	% $\rho_b$	% $\rho_{max}$	% $\rho_s$	Ratio $\rho_s/\rho_b$	Ratio $\rho_s/\rho_{max}$	$R_{us}$ (psi)	$R_{u,max}$ (psi)
3	40	3.71	2.031	1.4	0.38	0.69	450	614
	60	2.14	1.356	1.2	0.56	0.89	556	615
4	60	2.85	1.806	1.4	0.49	0.78	662	820
	75	2.07	1.445	1.2	0.58	0.83	702	820
5	60	3.35	2.123	1.6	0.48	0.75	766	975
	75	2.43	1.700	1.4	0.58	0.82	830	975

**Table 4.2** Relation between  $\epsilon_t$ ,  $\rho/\rho_b$ ,  $\phi$ , and  $\epsilon_t/\epsilon_y$  ( $f_y = 60$  ksi)

$\epsilon_t$	0.004	0.005	0.006	0.007	0.0075	0.008	0.009	0.010	0.040
$\rho/\rho_b$	0.714	0.625	0.555	0.500	0.476	0.454	0.417	0.385	0.117
$\epsilon_t/\epsilon_y$	2.0	2.5	3.0	3.5	3.75	4.0	4.5	5.0	20
$\phi$	0.82	0.9	0.9	0.9	0.9	0.9	0.9	0.9	0.9

The value of  $\beta_1$  in  $\rho_b$  is 0.85 when  $f'_c \leq 4000$  psi (30 N/mm<sup>2</sup>) and decreases by 0.05 for every increase of 1000 psi (7 N/mm<sup>2</sup>) in concrete strength. The steel percentage of balanced section,  $\rho_b$ , and the maximum allowable steel percentage,  $\rho_{max}$ , can be calculated for different values of  $f'_c$  and  $f_y$ , as shown in Table 4.1 or A.4.

It should be clarified that the designer has a wide range of choice between a large concrete section and relatively small percentage of steel,  $\rho$ , producing high ductility and a small section with a high percentage of steel with low ductility. A high value of the net tensile strain,  $\epsilon_t$ , indicates a high ductility and a relatively low percentage of steel. The limit of the net tensile strain for tension-controlled sections is 0.005, with  $\phi = 0.9$ . The strain limit of 0.004 can be used with a reduction in  $\phi$ . If the ductility index is represented by the ratio of the net tensile strain,  $\epsilon_t$ , to the yield strain,  $\epsilon_y = f_y/E_s$ , the relationship between  $\epsilon_t$ ,  $\rho/\rho_b$ ,  $\phi$ , and  $\epsilon_t/\epsilon_y$  is shown in Table 4.2 for  $f_y = 60$  ksi. Also, the ACI Code, Section 6.6.5.1, indicates that  $\epsilon_t$  should be  $\geq 0.0075$  for the redistribution of moments in continuous flexural members producing a ductility index of 3.75. It can be seen that adopting  $\epsilon_t \geq 0.005$  is preferable to the use of a higher steel ratio,  $\rho/\rho_b$ , with  $\epsilon_t = 0.004$ , because the increase in  $M_n$  is offset by a lower  $\phi$ . The value of  $\epsilon_t = 0.004$  represents the use of minimum steel percentage of 0.00333 for  $f'_c = 4$  ksi and  $f_y = 60$  ksi. This case should be avoided. The value of  $\phi$  between  $\epsilon_t = 0.005$  and  $\epsilon_t = 0.004$  can be calculated from Eq. 3.8:  $\phi = 0.65 + (\epsilon_t - 0.002) \left( \frac{250}{3} \right)$ .

The design moment equations were derived in the previous chapter in the following forms:

$$\phi M_n = M_u = R_u b d^2 \quad (3.21)$$

where

$$R_u = \phi \rho f_y \left( 1 - \frac{\rho f_y}{1.7 f'_c} \right) = \phi R_n \quad (3.22)$$

where  $\phi = 0.9$  for tension-controlled sections and  $\phi < 0.9$  for sections in the transition region:

$$\phi M_n = M_u = \phi A_s f_y \left( d - \frac{A_s f_y}{1.7 f'_c b} \right) \quad (3.19a)$$

Also,

$$\phi M_n = M_u = \phi \rho f_y b d^2 \left( 1 - \frac{\rho f_y}{1.7 f'_c} \right) \quad (3.20)$$

We can see that for a given factored moment and known  $f'_c$  and  $f_y$  there are three unknowns in these equations: the width,  $b$ , the effective depth of the section,  $d$ , and the steel ratio,  $\rho$ . A unique solution is not possible unless values of two of these three unknowns are assumed. Usually,  $\rho$  is assumed (e.g., using  $\rho_{\max}$ ), and  $b$  can also be assumed.

Based on the preceding discussion, the following cases may develop for a given  $M_u$ ,  $f'_c$ , and  $f_y$ :

1. If  $\rho$  is assumed, then  $R_u$  can be calculated from Eq. 3.22, giving  $b d^2 = M_u / R_u$ . The ratio of  $d/b$  usually varies between 1 and 3, with a practical ratio of 2. Consequently,  $b$  and  $d$  can be determined, and  $A_s = \rho b d$ . The ratio  $\rho$  for a singly reinforced rectangular section must be equal to or less than  $\rho_{\max}$ , as given in Eq. 3.31. It is a common practice to assume a value of  $\rho$  that ranges between  $\frac{1}{2}\rho_{\max}$  and  $\frac{1}{2}\rho_b$ . Table 4.1 gives suggested values of the steel ratio  $\rho$  to be used in singly reinforced sections when  $\rho$  is not assigned. For example, if  $f_y = 60$  ksi, the value  $\rho_s = 1.4\%$  is suggested for  $f'_c = 4$  ksi, 1.6% for  $f'_c = 5$  ksi, and 1.2% for  $f'_c = 3$  ksi. The designer may use  $\rho$  up to  $\rho_{\max}$ , which produces the minimum size of the singly reinforced concrete section. Using  $\rho_{\min}$  will produce the maximum concrete section. If  $b$  is assumed in addition to  $\rho$ , then  $d$  can be determined as

$$d = \sqrt{\frac{M_u}{R_u b}} \quad (4.1)$$

If  $d/b = 2$ , then  $d = \sqrt[3]{2M_u/R_u}$  and  $b = d/2$ , rounded to the nearest higher inch.

2. If  $b$  and  $d$  are given, then the required reinforcement ratio  $\rho$  can be determined by rearranging Eq. 3.20 to obtain

$$\rho = \frac{0.85 f'_c}{f_y} \left[ 1 - \sqrt{1 - \frac{4M_u}{1.7 \phi f'_c b d^2}} \right] \quad (4.2)$$

$$= \frac{0.85 f'_c}{f_y} \left[ 1 - \sqrt{1 - \frac{2R_u}{0.85 f'_c}} \right] \quad (4.2a)$$

or

$$\rho = \frac{f'_c}{f_y} \left[ 0.85 - \sqrt{(0.85)^2 - Q} \right]$$

where

$$Q = \left( \frac{1.7}{\phi f'_c} \right) \frac{M_u}{b d^2} = \left( \frac{1.7}{\phi f'_c} \right) R_u \quad (4.3)$$

$$A_s = \rho b d = \left( \frac{f'_c}{f_y} \right) b d \left[ 0.85 - \sqrt{(0.85)^2 - Q} \right] \quad (4.4)$$

where all units are in kips (or pounds) and inches and  $Q$  is dimensionless. For example, if  $M_u = 2440$  K · in.,  $b = 12$  in.,  $d = 18$  in.,  $f'_c = 3$  ksi, and  $f_y = 60$  ksi, then  $\rho = 0.01389$  (from Eq. 4.2) and  $A_s = \rho b d = 0.01389(12)(18) = 3.0$  in.<sup>2</sup>, or directly from Eq. 4.4,  $Q = 0.395$  and

$A_s = 3.0 \text{ in.}^2$  When  $b$  and  $d$  are given, it is better to check if compression steel is or is not required because of a small  $d$ . This can be achieved as follows:

- a. Calculate  $\rho_{\max}$  and  $R_u(\max) = \phi \rho_{\max} f_y [1 - (\rho_{\max} f_y / 1.7 f'_c)]$ .
  - b. Calculate  $\phi M_n(\max) = R_u b d^2$ , the design moment strength of a singly reinforced concrete section.
  - c. If  $M_u < \phi M_n(\max)$ , then no compression reinforcement is needed. Calculate  $\rho$  and  $A_s$  from the preceding equations.
  - d. If  $M_u > \phi M_n(\max)$ , then compression steel is needed. In this case, the design procedure is explained in Section 4.4.
3. If  $\rho$  and  $b$  are given, calculate  $R_u$ :

$$R_u = \phi \rho f_y \left( 1 - \frac{\rho f_y}{1.7 f'_c} \right)$$

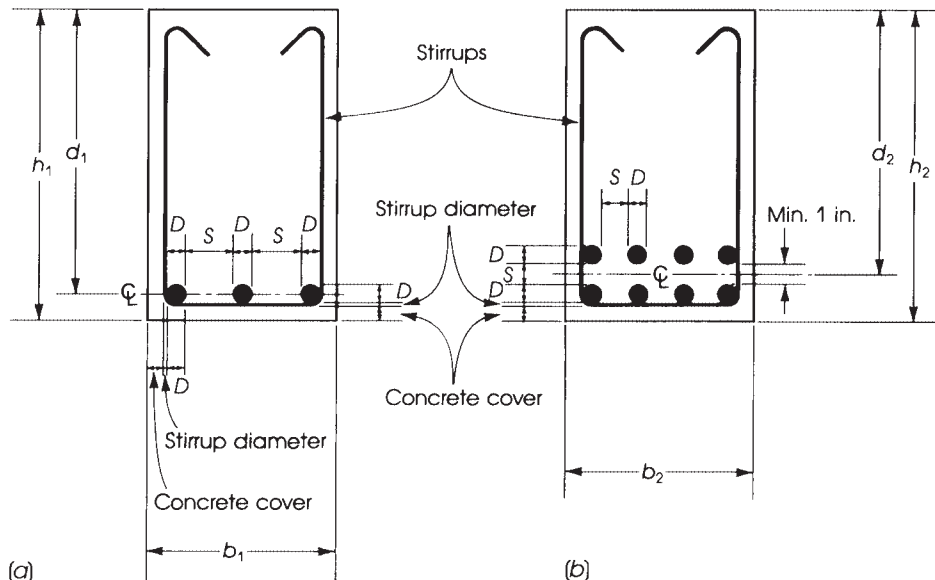
Then calculate  $d$  from Eq. 4.1:

$$d = \sqrt{\frac{M_u}{R_u b}} \quad \text{and} \quad A_s = \rho b d$$

### 4.3 SPACING OF REINFORCEMENT AND CONCRETE COVER

#### 4.3.1 Specifications

Figure 4.1 shows two reinforced concrete sections. The bars are placed such that the clear spacing shall be at least the greatest of 1 in. (25 mm), nominal bar diameter  $D$ , and  $(4/3)d_{\text{agg}}$  (nominal



**Figure 4.1** Spacing of steel bars in (a) one row or (b) two rows.

maximum size of the aggregate), (ACI Code, Section 25.2.1). Vertical clear spacing between bars in more than one layer shall not be less than 1 in. (25 mm), according to the ACI Code, Section 25.2.2. Also for reinforcement of more than two layers, the upper layer reinforcement shall be placed directly above the reinforcement of the lower layer.

The width of the section depends on the number,  $n$ , and diameter of bars used. Stirrups are placed at intervals; their diameters and spacings depend on shear requirements, to be explained later. At this stage, stirrups of  $\frac{3}{8}$  in. (10 mm) diameter can be assumed to calculate the width of the section. There is no need to adjust the width,  $b$ , if different diameters of stirrups are used. The specified concrete cover for cast-in-place and precast concrete is given in the ACI Code, Section 20.6.1. Concrete cover for beams and girders is equal to  $\frac{3}{2}$  in. (38 mm), and that for slabs is equal to  $\frac{3}{4}$  in. (20 mm), when concrete is not exposed to weather or in contact with the ground.

### 4.3.2 Minimum Width of Concrete Sections

The general equation for the minimum width of a concrete section can be written in the form

$$b_{\min} = nD + (n - 1)s + 2(\text{stirrup diameter}) + 2(\text{concrete cover}) \quad (4.5a)$$

where

$n$  = number of bars

$D$  = diameter of largest bar used

$s$  = spacing between bars (equal to  $D$  or 1 in., whichever is larger)

If the stirrup's diameter is taken equal to  $\frac{3}{8}$  in. (10 mm) and concrete cover equals  $\frac{3}{2}$  in. (38 mm), then

$$b_{\min} = nD + (n - 1)s + 3.75 \text{ in. (95mm)} \quad (4.5b)$$

This equation, if applied to the concrete sections in Fig. 4.1, becomes

$$b_1 = 3D + 2S + 3.75 \text{ in. (95 mm)}$$

$$b_2 = 4D + 3S + 3.75 \text{ in. (95 mm)}$$

To clarify the use of Eq. 4.5, let the bars used in sections of Fig. 4.1 be no. 10 (32-mm) bars. Then

$$b_1 = \begin{cases} 5 \times 1.27 + 3.75 = 10.10 \text{ in. (} s = D) & \text{say, 11 in.} \\ 5 \times 32 + 95 = 225 \text{ mm} & \text{say, 250 mm} \end{cases}$$

$$b_2 = \begin{cases} 7 \times 1.27 + 3.75 = 12.64 \text{ in. (} s = D) & \text{say, 13 in.} \\ 7 \times 32 + 95 = 319 \text{ mm} & \text{say, 320 mm} \end{cases}$$

If the bars used are no. 6 (20 mm), the minimum widths become

$$b_1 = \begin{cases} 3 \times 0.75 + 2 \times 1 + 3.75 = 8.0 \text{ in.} & (s = 1 \text{ in.}) \\ 3 \times 20 + 2 \times 25 + 95 = 205 \text{ mm} & \text{say, 210 mm} \end{cases}$$

$$b_2 = \begin{cases} 4 \times 0.75 + 3 \times 1 + 3.75 = 9.75 \text{ in.} & \text{say, 10 in.} \\ 4 \times 20 + 3 \times 25 + 95 = 250 \text{ mm} & \end{cases}$$

The width of the concrete section shall be increased to the nearest inch. Table 1 gives the minimum beam width for different numbers of bars in the section.



### 4.3.3 Minimum Overall Depth of Concrete Sections

The effective depth,  $d$ , is the distance between the extreme compressive fibers of the concrete section and the centroid of the tension reinforcement. The minimum total depth is equal to  $d$  plus the distance from the centroid of the tension reinforcement to the extreme tension concrete fibers, which depends on the number of layers of the steel bars. In application to the sections shown in Fig. 4.1,

$$\begin{aligned} h_1 &= d_1 + \frac{1}{2}D + \frac{3}{8}\text{in.} + \text{concrete cover}(1.5\text{ in.}) \\ &= d_1 + \frac{1}{2}D + 1.857\text{ in.}(50\text{ mm}) \end{aligned}$$

for one row of steel bars and

$$\begin{aligned} h_2 &= d_2 + 0.5 + D + \frac{3}{8}\text{in.} + \text{concrete cover}(1.5\text{ in.}) \\ &= d_2 + D + 2.375\text{ in.}(60\text{ mm}) \end{aligned}$$

for two layers of steel bars. The overall depth,  $h$ , shall be increased to the nearest half inch (10 mm) or, better, to the nearest inch (20 mm in SI). For example, if  $D = 1\text{ in.}$  (25 mm),  $d_1 = 18.9\text{ in.}$  (475 mm), and  $d_2 = 20.1\text{ in.}$  (502 mm),

$$\text{Minimum } h_1 = 18.9 + 0.5 + 1.875 = 21.275\text{ in.}$$

say, 21.5 in. or 22 in.,

$$h_1 = 475 + 13 + 50 = 538\text{ mm}$$

say, 540 mm or 550 mm, and

$$\text{Minimum } h_2 = 20.1 + 1.0 + 2.375 = 23.475\text{ in.}$$

say, 23.5 in. or 24 in.,

$$h_2 = 502 + 25 + 60 = 587\text{ mm}$$

say, 590 mm or 600 mm.

If no. 9 or smaller bars are used, a practical estimate of the total depth,  $h$ , can be made as follows:

$$h = \begin{cases} d + 2.5\text{ in.}(65\text{ mm}) & \text{for one layer of steel bars} \\ d + 3.5\text{ in.}(90\text{ mm}) & \text{for two layers of steel bars} \end{cases}$$

For more than two layers of steel bars, a similar approach may be used.

It should be mentioned that the minimum spacing between bars depends on the maximum size of the coarse aggregate used in concrete. The nominal maximum size of the coarse aggregate shall not be larger than one-fifth of the narrowest dimension between sides of forms, or one-third of the depth of slabs, or three-fourths of the minimum clear spacing between individual reinforcing bars or bundles of bars (ACI Code, Section 26.4.2.1).

#### Example 4.1

Design a simply reinforced rectangular section to resist a factored moment of 361 K·ft using the maximum steel percentage  $\rho_{\max}$  for tension-controlled sections to determine its dimension. Given:  $f'_c = 3\text{ ksi}$  and  $f_y = 60\text{ ksi}$ .

**Solution**

For  $f'_c = 3$  ksi,  $f_y = 60$  ksi, and  $\beta_1 = 0.85$ ,  $\rho_{\max}$  for a tension-controlled section is calculated as follows ( $\phi = 0.9$ ):

$$\rho_b = (0.85)\beta_1 \left( \frac{f'_c}{f_y} \right) \left[ \frac{87}{87 + f_y} \right]$$

$$\rho = (0.85)^2 \left( \frac{3}{60} \right) \left( \frac{87}{147} \right) = 0.0214$$

$$\rho_{\max} = \rho_b \left( \frac{0.003 + f_y/E_s}{0.008} \right) = 0.63375\rho_b = 0.01356 \quad (\text{Table 4.1})$$

$$\begin{aligned} R_{u,\max} &= \phi \rho_{\max} f_y \left( 1 - \frac{\rho_{\max} f_y}{1.7 f'_c} \right) \\ &= 0.9 \times 0.01356 \times 60 \times \left( 1 - \frac{0.01356 \times 60}{1.7 \times 3} \right) = 0.615 \text{ ksi} \end{aligned}$$

(Or, use the tables in Appendix A or Table 4.1.)

Since  $M_u = R_u b d^2$ ,

$$b d^2 = \frac{M_u}{R_u} = \left( \frac{361 \times 12}{0.615} \right) = \frac{4332}{0.615} = 7043 \text{ in.}^3$$

Thus, for the following assumed  $b$ , calculate  $d$  and  $A_s = \rho b d$ :

$$\rho = \frac{0.85 f'_c}{f_y} \left[ 1 - \sqrt{1 - \frac{4 M_u}{1.7 f'_c b d^2}} \right]$$

$b = 10$ in.	$d = 26.5$ in.	$A_s = 3.59$ in. <sup>2</sup>	
$b = 12$ in.	$d = 24.2$ in.	$A_s = 3.94$ in. <sup>2</sup>	six no. 8 bars ( $A_s = 4.71$ in. <sup>2</sup> )
$b = 14$ in.	$d = 22.4$ in.	$A_s = 4.95$ in. <sup>2</sup>	five no. 9 bars ( $A_s = 5.0$ in. <sup>2</sup> )
$b = 16$ in.	$d = 21.0$ in.	$A_s = 4.55$ in. <sup>2</sup>	

The choice of the effective depth  $d$  depends on three factors:

- 1. Width  $b$  Required.** A small width will result in a deep beam that decreases the headroom available. Furthermore, a deep narrow beam may lower the design moment strength of the structural member due to possible lateral deformation.
- 2. Amount and Distribution of Reinforcing Steel.** A narrow beam may need more than one row of steel bars, thus increasing the total depth of the section.
- 3. Wall Thickness.** If cement block walls are used, the width  $b$  is chosen to be equal to the wall thickness. Exterior walls in buildings in most cases are thicker than interior walls. The architectural plan of the structure will show the different thicknesses.

A reasonable choice of  $d/b$  varies between 1 and 3, with practical value about 2. It can be seen from the previous calculations that the deeper the section, the more economical it is, as far as the quantity of concrete used, expressed by the area  $bd$  of a 1-ft length of the beam. Alternatively, calculate  $bd^2 = M_u/R_u$  and then choose adequate  $b$  and  $d$ .

The area of the steel reinforcement,  $A_s$ , is equal to  $\rho b d$ . The area of steel needed for the different choices of  $b$  and  $d$  for this example was shown earlier. Because the steel percentage required is constant ( $\rho_{\max} = 0.01356$ ),  $A_s$  is proportional to  $bd$ . For a choice of a 12 × 24.2-in. section, the required  $A_s$  is 4.65 in.<sup>2</sup> Choose six no. 8 bars in two rows (actual  $A_s = 4.71$  in.<sup>2</sup>). The minimum  $b$  required for three

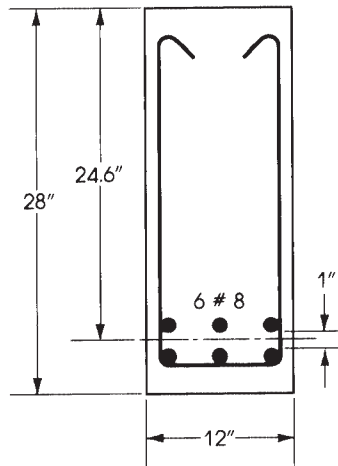


Figure 4.2 Example 4.1.

no. 8 bars in one row is 8.9 in. < 12 in., and total  $h = 24.2 + 3.5 = 27.7$  in., say, 28 in. (actual  $d = 24.6$  in.). Another choice is a section with a  $14 \times 22.4$ -in. section with a total depth ( $h$ ) of 25 in. and five no. 9 bars in one row. The choice of bars depends on:

1. Adequate placement of bars in the section, normally in one or two rows, fulfilling the restrictions of the ACI Code for minimum spacing between bars.
2. The area of steel bars chosen closest to the required calculated steel area.

The final section is shown in Fig. 4.2.

### Example 4.2

Design a simply reinforced rectangular section with  $\rho$  of about 1%. Given:  $f'_c = 3$  ksi and  $f_y = 60$  ksi.

#### Solution

1. For  $f'_c = 3$  ksi and  $f_y = 60$  ksi,  $\rho_{\max} = 0.01356$ .  
Since  $\rho < 0.01356$ , the section is tensioned controlled, and  $\phi = 0.9$ ,

$$R_u = \phi \rho f_y \left( 1 - \frac{\rho f_y}{1.7 f'_c} \right)$$

$$= 0.9 \times 0.01 \times 60 \left( 1 - \frac{0.01 \times 60}{1.7 \times 3} \right) = 0.476 \text{ ksi}$$

(From the tables in Appendix A, for  $\rho = 0.01$ ,  $R_u = 476$  psi.)

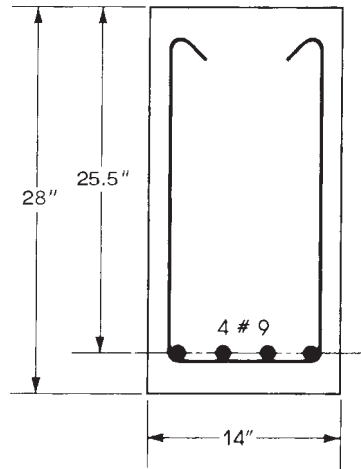
2.  $bd^2 = M_u / R_u = 4332 / 0.476 = 9100 \text{ in.}^3$  Choosing  $b = 14$  in. and  $d = 25.5$  in.,

$$A_s = \rho bd = 0.01 \times 14 \times 25.5 = 3.57 \text{ in.}^2$$

Choose four no. 9 bars in one layer;  $A_s = 4.00 \text{ in.}^2$ :

$$b_{\min} = nD + (n - 1)s + 3.75$$

$$= 7 \times 1.128 + 3.75 = 11.7 \text{ in.} < 14 \text{ in.} \quad (\text{width is sufficient})$$



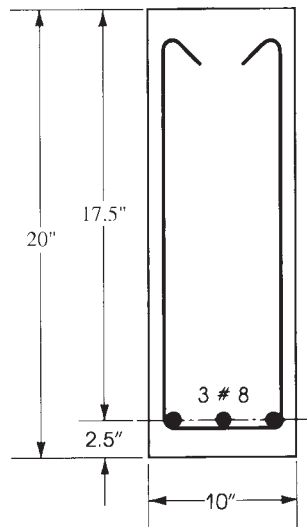
**Figure 4.3** Example 4.2.

$$\begin{aligned}
 h_{\min} &= d + \frac{D}{2} + 1.875 \quad (\text{assume } 1.5 \text{ in cover}) \\
 &= 25.5 + \frac{1.138}{2} + 1.875 = 27.94 \text{ in.} \quad \text{say, } 28 \text{ in.} \quad (d = 25.5 \text{ in.})
 \end{aligned}$$

The final cross section is shown in Fig. 4.3.

### Example 4.3

Find the necessary reinforcement for a given section that has a width of 10 in. and a total depth of 20 in. (Fig. 4.4) if it is subjected to an external factored moment of 163 K-ft. Given:  $f'_c = 4$  ksi and  $f_y = 60$  ksi.



**Figure 4.4** Example 4.3.

**Solution**

1. Assuming one layer of no. 8 steel bars (to be checked later),  $d = 20 - 0.5 - 1.875 = 17.625$  in. (or  $d = 20 - 2.5$  in. = 17.5 in.).
2. Check if the section is adequate without compression reinforcement. Compare the moment strength of the section (using  $\rho_{\max}$  for the tension-controlled condition). For  $f'_c = 4$  ksi and  $f_y = 60$  ksi,  $\rho_{\max} = 0.01806$ :

$$R_{u,\max} = \phi \rho_{\max} f_y \left( 1 - \frac{\rho_{\max} f_y}{1.7 f'_c} \right) = 820 \text{ psi} \quad (\text{from Table 4.1})$$

The moment strength of a singly reinforced basic section is

$$\begin{aligned} \phi M_{n,\max} &= R_{u,\max} b d^2 = 0.82(10)(17.5)^2 \\ &= 2511 \text{ K} \cdot \text{in.} > 163 \times 12 = 1956 \text{ K} \cdot \text{in.} \end{aligned}$$

Therefore,  $\rho < \rho_{\max}$  and the section is singly reinforced and is tension controlled ( $\phi = 0.9$ ).

3. Calculate  $\rho$  from Eq. 4.2 or 4.3:

$$Q = \left( \frac{1.7}{\phi f'_c} \right) \times \frac{M_u}{b d^2} = \left( \frac{1.7}{0.9 \times 4} \right) \times \left( \frac{1956}{10 \times 17.5^2} \right) = 0.302$$

$$\rho = \frac{f'_c}{f_y} \left[ 0.85 - \sqrt{(0.85)^2 - Q} \right] = 0.0134 < \rho_{\max} \quad (\text{tension - controlled condition})$$

$A_s = \rho b d = 0.0134(10)(17.5) = 2.345 \text{ in.}^2$  Use three no. 8 bars ( $A_s = 2.35 \text{ in.}^2$ ) in one row,  $b_{\min} < 10$  in. The final section is shown in Fig. 4.4.

**Example 4.4**

Find the necessary reinforcement for a given section,  $b = 15$  in., if it is subjected to a factored moment of 313 K · ft. Use  $f'_c = 4$  ksi and  $f_y = 60$  ksi.

**Solution**

1. For  $f'_c = 4$  ksi and  $f_y = 60$  ksi, and from Table 4.1,  $\rho_b = 0.0285$ ,  $\rho_{\max} = 0.01806$  (tension-controlled section),  $R_{u,\text{texmax}} = 820$  psi.
2. Using  $\rho_{\max} = 0.01806$  and  $R_u = 820$  psi,

$$b d^2 = \frac{M_u}{R_u} = \frac{313(12)}{0.820} = 4581 \text{ in.}^3$$

For  $b = 15$  in. and  $d = 17.50$ ,

$$A_s = \rho b d = 0.01806(15)(17.5) = 4.74 \text{ in.}^2$$

Choose four no. 10 bars,  $A_s = 5.08 \text{ in.}^2 > 4.74 \text{ in.}^2$  Bars can be placed in one row,  $b_{\min} = 12.7$  in. in Table A.7. Total depth ( $h$ ) = 17.5 + 2.5 = 20 in.

**Discussion**

1. Since a steel area of 5.08 in.<sup>2</sup> used is greater than 4.74 in.<sup>2</sup> required (the limit for a tension-controlled section with  $\phi = 0.9$ ), the section is in the transition zone. Actually, the section is underreinforced and the nominal moment  $M_n = A_s f_y (d - a/2) = 368.6 \text{ K} \cdot \text{ft}$  ( $A_s = 5.08 \text{ in.}^2$  and  $a = 5.976$  in.). If  $\phi = 0.9$  is used, then  $\phi M_n = 331.7 \text{ K} \cdot \text{ft}$ .

2. The ACI Code indicates that for sections in the transition zone,  $\phi < 0.9$ , and  $\epsilon_t \geq 0.004$ . Checking  $\epsilon_t = [0.005/(\rho/\rho_b)] - 0.003$ ,

$$\rho = \frac{5.08}{15 \times 17.5} = 0.01935 \quad \frac{\rho}{\rho_b} = 0.679$$

$$\epsilon_t = \left( \frac{0.00507}{0.679} \right) - 0.003 = 0.004467 > 0.004$$

Or, alternatively, calculate  $a = 5.08 \times 60 / (0.85 \times 4 \times 15) = 5.976$ ,  $c = a / 0.85 = 7.03$ ,  $d_t = d = 17.5$  in. Then  $\epsilon_t = 0.003(d_t - c) / c = 0.004467$ . Calculate

$$\phi = 0.65 + (\epsilon_t - 0.002) \left( \frac{250}{3} \right) = 0.856$$

$$\phi M_n = 0.856(368.6) = 315.4 \text{ K} \cdot \text{ft}$$

3. It can be noticed that, despite an additional amount of steel,  $5.08 - 4.67 = 0.41 \text{ in.}^2$  (or about 9%), the design moment strength remained the same. This is because the strength reduction factor,  $\phi$ , was decreased. Therefore, the design of sections within the tension-controlled zone with  $\phi = 0.9$  gives a more economical design based on the ACI Code limitations.

#### 4.4 RECTANGULAR SECTIONS WITH COMPRESSION REINFORCEMENT

A singly reinforced section has its moment strength when  $\rho_{\max}$  of steel is used. If the applied factored moment is greater than the internal moment strength, as in the case of a limited cross section, a doubly reinforced section may be used, adding steel bars in both the compression and the tension zones. Compression steel will provide compressive force in addition to the compressive force in the concrete area.

##### 4.4.1 Assuming One Row of Tension Bars

The procedure for designing a rectangular section with compression steel when  $M_u, f'_c, b, d$ , and  $d'$  are given can be summarized as follows:

1. Calculate the balanced and the maximum steel ratio,  $\rho_{\max}$ , using Eqs. 3.18 and Eqs. 3.31:

$$\rho_b = 0.85 \beta_1 \frac{f'_c}{f_y} \left( \frac{87}{87 + f_y} \right)$$

Calculate  $A_{s, \max} = A_{s1} = \rho_{\max} b d$  (maximum steel area as singly reinforced).

2. Calculate  $R_{u, \max}$  using  $\rho_{\max}$  ( $\phi = 0.9$ ):

$$R_{u, \max} = \phi \rho_{\max} f_y \left( 1 - \frac{\rho_{\max} f_y}{1.7 f'_c} \right)$$

( $R_{u, \max}$  can be obtained from the tables in Appendix A or Table 4.1.)

3. Calculate the moment strength of the section,  $M_{u1}$ , as singly reinforced using  $\rho_{\max}$  and  $R_{u, \max}$ :

$$M_{u1} = R_{u, \max} b d^2$$

If  $M_{u1} < M_u$  (the applied moment), then compression steel is needed. Go to the next step. If  $M_{u1} > M_u$ , then compression steel is not needed. Use Eq. 4.2 to calculate  $\rho$  and  $A_s = \rho bd$ , as explained earlier.

4. Calculate  $M_{u2} = M_u - M_{u1}$ , the moment to be resisted by compression steel.
5. Calculate  $A_{s2}$  from  $M_{u2} = \phi A_{s2} f_y (d - d')$ .  
Then calculate the total tension reinforcement,  $A_s$ :
6. Calculate the stress in the compression steel as follows:
  - a. Calculate  $f'_s = 87[(c - d')/c]$ ksi  $\leq f_y$  ( $f'_s$  cannot exceed  $f_y$ ).
  - b. Or,  $\epsilon'_s$  can be calculated from the strain diagram, and  $f'_s = (\epsilon'_s \cdot E_s)$ . If  $\epsilon'_s \geq \epsilon_y$ , then compression steel yields and  $f'_s = f_y$ .
  - c. Calculate  $A'_s$  from  $M_{u2} = \phi A'_s f'_s (d - d')$ . If  $f'_s = f_y$ , then  $A'_s = A_{s2}$ . If  $f'_s < f_y$ , then  $A'_s > A_{s2}$ , and  $A'_s = A_{s2}(f_y/f'_s)$ .
7. Choose bars for  $A_s$  and  $A'_s$  to fit within the section width,  $b$ . In most cases,  $A_s$  bars will be placed in two rows, whereas  $A'_s$  bars are placed in one row.
8. Calculate  $h = d + 2.5$  in. for one row of tension bars and  $h = d + 3.5$  in. for two rows of tension steel. Round  $h$  to the next higher inch. Now check that  $[\rho - \rho'(f'_s/f_y)] < \rho_{\max}$  using the new  $d$  or check that  $A_{s,\max} = bd[\rho_{\max} + \rho'(f'_s/f_y)] \geq A_s$  (used):

$$\rho = \frac{A_s}{bd} \quad \text{and} \quad \rho' = \frac{A'_s}{bd}$$

This check may not be needed if  $\rho_{\max}$  is used in the basic section.

9. If desired, the design moment strength of the final section,  $\phi M_n$ , can be calculated and compared with the applied moment,  $M_u$ :  $\phi M_n \geq M_u$ . Note that a steel ratio  $\rho$  smaller than  $\rho_{\max}$  can be assumed in step 1, say  $\rho = 0.6\rho_b$  or  $\rho = 0.9\rho_{\max}$ , so that the final tension bars can be chosen to meet the given  $\rho_{\max}$  limitation.
10. The strain at the bars level can be checked as follows:

$$\epsilon_t = \left( \frac{d_t - c}{c} \right) 0.003 \geq 0.005$$

#### 4.4.2 Assuming Two Rows of Tension Bars

In the case of two rows of bars, it can be assumed that  $d = h - 3.5$  in. and  $d_t = h - 2.5$  in. =  $d + 1.0$  in. Two approaches may be used to design the section.

1. One approach is to assume a strain at the level of the centroid of the tension steel equal to 0.005 or  $\epsilon_s = 0.005$  (at the  $d$  level). In this case, the strain in the lower row of bars is greater than 0.005:  $\epsilon_t = (d_t - c/c)0.003 > 0.005$ , which still meets the ACI Code limitation. For this case, follow the above steps 1 to 9. Example 4.6, solution 1, explains this approach.
2. A second approach is to assume a strain  $\epsilon_t = 0.005$  at the level of the lower row of bars,  $d_t$ . In this case, the strain at the level of the centroid of bars is less than 0.005:  $\epsilon_s = [(d_t - c)/c]0.003 < 0.005$ , which is still acceptable. Example 4.6, solution 2, explains this approach. The solution can be summarized as follows:
  - a. Calculate  $d_t = h - 2.5$  in. and then form the strain diagram and calculate  $c$ , the depth of the neutral axis:

$$c = \left( \frac{0.003}{0.003 + \epsilon_t} \right) d_t$$

For  $\varepsilon_t = 0.005$ ,

$$c = \left(\frac{3}{8}\right) d_t \quad \text{and} \quad a = \beta_1 c$$

b. Calculate the compression force in the concrete:

$$C_1 = 0.85f'_c ab = T_1 = A_{s1}f_y$$

Determine  $A_{s1}$ . Calculate  $M_{u1} = \phi A_{s1}f_y(d - a/2)$ ;  $\rho_1 = A_{s1}/bd$ ,  $\phi = 0.9$ .

c. Calculate  $M_{u2} = M_u - M_{u1}$ ; assume  $d' = 2.5$  in.

d. Calculate  $A_{s2}$ :  $M_{u2} = \phi A_{s2}f_y(d - d')$ ,  $f'_c = f_y$ ,  $\phi = 0.9$ . Total  $A_s = A_{s1} + A_{s2}$ .

e. Check if compression steel yields similar to step 6 in Section 4.4.1.

### Example 4.5

A beam section is limited to a width  $b = 10$  in. and a total depth  $h = 22$  in. and has to resist a factored moment of  $226.5 \text{ K} \cdot \text{ft}$ . Calculate the required reinforcement. Given:  $f'_c = 3 \text{ ksi}$  and  $f_y = 50 \text{ ksi}$ .

### Solution

- Determine the design moment strength that is allowed for the section as singly reinforced based on tension-controlled conditions. This is done by starting with  $\rho_{\max}$ . For  $f'_c = 3 \text{ ksi}$  and  $f_y = 50 \text{ ksi}$  and from Eqs. 3.18, 3.22, and 3.31,

$$\rho_b = 0.0275 \quad \rho_{\max} = 0.01624 \quad R_u = 614 \text{ psi}$$

$$M_u = R_u b d^2 \quad b = 10 \text{ in.} \quad d = 22 - 3.5 = 18.5 \text{ in.}$$

$$M_u = 226.5 \times 12 = 2718 \text{ K} \cdot \text{in.}$$

(This calculation assumes two rows of steel, to be checked later.) Assume  $M_{u1} = 0.614 \times 10 \times (18.5)^2 = 2101 \text{ K} \cdot \text{in.} = \max \phi M_n$ , as singly reinforced. Design  $M_u = 2718 \text{ K} \cdot \text{in.} > 2101 \text{ K} \cdot \text{in.}$  Therefore, compression steel is needed to carry the difference.

- Compute  $A_{s1}$ ,  $M_{u1}$ , and  $M_{u2}$ :

$$A_{s1} = \rho_{\max} b d = 0.01624 \times 10 \times 18.5 = 3.0 \text{ in.}^2$$

$$M_{u1} = 2101 \text{ K} \cdot \text{in.}$$

$$M_{u2} = M_u - M_{u1} = 2718 - 2102 = 617 \text{ K} \cdot \text{in.}$$

- Calculate  $A_{s2}$  and  $A'_s$ , the additional tension and compression steel due to  $M_{u2}$ . Assume  $d' = 2.5$  in.;  $M_{u2} = \phi A_{s2}f_y(d - d')$ :

$$A_{s2} = \frac{M_{u2}}{\phi f_y(d - d')} = \frac{617}{0.9 \times 50(18.5 - 2.5)} = 0.86 \text{ in.}^2$$

Total tension steel is equal to  $A_s$ :

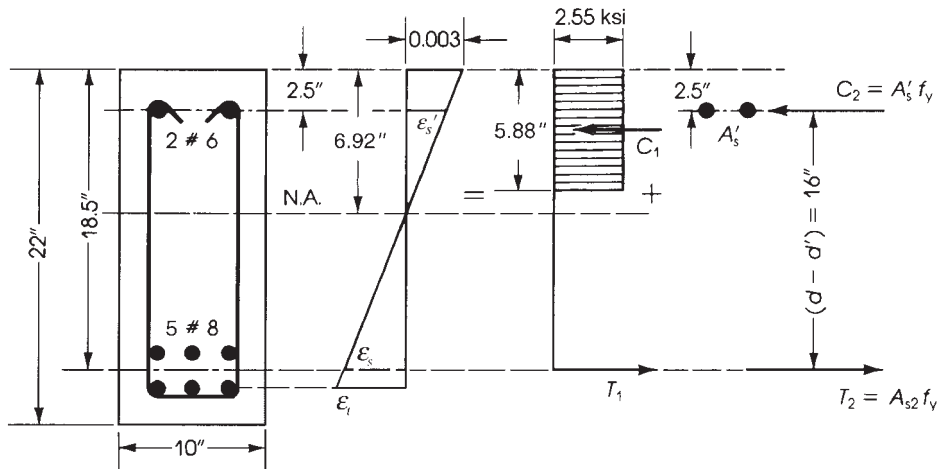
$$A_s = A_{s1} + A_{s2} = 3.0 + 0.86 = 3.86 \text{ in.}^2$$

The compression steel has  $A'_s = 0.86 \text{ in.}^2$  (in  $A'_s$  yields).

- Check if compression steel yields:

$$\varepsilon_y = \frac{f_y}{29,000} = \frac{50}{29,000} = 0.00172$$





**Figure 4.5** Example 4.5: Doubly reinforced concrete section.

$$\text{Let } a = (A_s f_y) / (0.85 f'_c b) = (3.0 \times 50) / (0.85 \times 3 \times 10) = 5.88 \text{ in.}$$

$$c(\text{distance to neutral axis}) = \frac{a}{\beta_1} = \frac{5.88}{0.85} = 6.92 \text{ in.}$$

$\epsilon'_s$  = strain in compression steel (from strain triangles)

$$= 0.003 \times \left( \frac{6.92 - 2.5}{6.92} \right) = 0.00192 > \epsilon_y = 0.00172$$

5. Check  $\epsilon_t$ :

$$\rho_1 = \frac{3}{10 \times 18.5} = 0.016216$$

$$\frac{\rho_1}{\rho_b} = 0.5897 \quad f_y = 50$$

From Eq. 3.24,  $\epsilon_{t_s} = 0.005$  is assumed at the centroid of the tension steel for  $\rho_{\max}$  and  $R_u$  used. Calculate  $\epsilon_t$  (at the lower row of bars):

$$d_t = 22 - 2.5 = 19.5 \text{ in.}$$

$$\begin{aligned} \epsilon_t &= \left( \frac{d_t - c}{c} \right) 0.003 \\ &= \left( \frac{19.5 - 6.92}{6.92} \right) 0.003 \\ &= 0.00545 > 0.005 \end{aligned}$$

as expected.

6. Choose steel bars as follows:  $A_s = 3.86 \text{ in.}^2$  Choose five no. 8 bars ( $A_s = 3.95 \text{ in.}^2$ ) in two rows, as assumed;  $A'_s = 0.86 \text{ in.}^2$  Choose two no. 6 bars ( $A'_s = 0.88 \text{ in.}^2$ ).

7. Check actual  $d$ : Actual  $d = 22 - (1.5 + 0.375 + 1.5) = 18.625 \text{ in.}$  It is equal approximately to the assumed depth. The final section is shown in Fig. 4.5.

**Example 4.6**

A beam section is limited to  $b = 12$  in. and a total depth  $h = 20$  in. and is subjected to a factored moment  $M_u = 298.4$  K·ft. Determine the necessary reinforcement using  $f'_c = 4$  ksi and  $f_y = 60$  ksi. (Refer to Fig. 4.6.)

**Solution 1: Two Solutions Are Presented**

1. Determine the maximum moment capacity of the section as singly reinforced based on tension-controlled conditions. For  $f'_c = 4$  ksi and  $f_y = 60$  ksi,  $\rho_{\max} = 0.01806$  and  $R_u = 820$  psi (Table 4.1). Assuming two rows of bars,  $d = 20 - 3.5 = 16.5$  in.:

$$\text{Max}M_{u1} = R_{u\max}bd^2 = 0.82(12)(16.5)^2 = 2679\text{K} \cdot \text{in.} = 223.25\text{K} \cdot \text{ft}$$

The design moment  $M_u = 298.4 \times 12 = 3581$  K·in.  $> M_{u1}$ ; therefore, compression steel is needed.

2. Calculate  $A_{s1}$ ,  $M_{u2}$ ,  $A_{s2}$ , and  $A_s$ :

$$A_{s1} = \rho_{\max}bd = 0.01806(12)(16.5) = 3.576\text{ in.}^2$$

$$M_{u2} = M_u - M_{u1} = 3581 - 2679 = 902\text{K} \cdot \text{in.}$$

$$M_{u2} = \phi A_{s2}f_y(d - d') \quad (\text{assume } d' = 2.5\text{ in.})$$

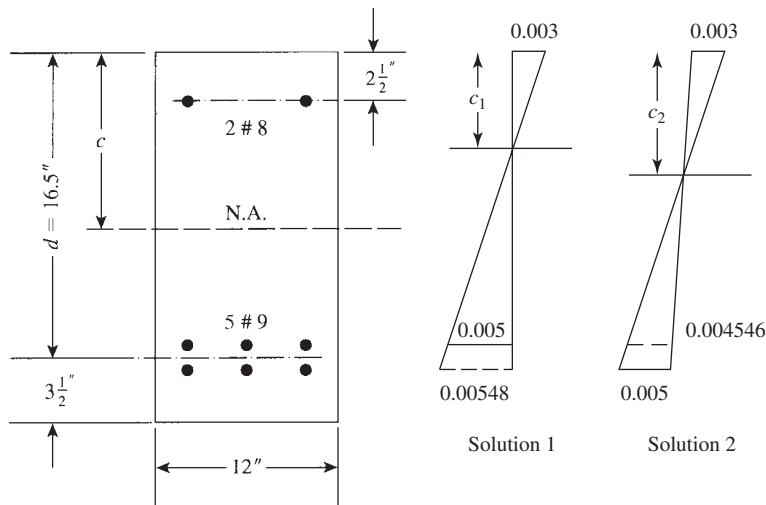
$$902 = 0.9A_{s2}(60)(16.5 - 2.5), A_{s2} = 1.19\text{ in.}^2$$

$$\text{Total } A_s = A_{s1} + A_{s2} = 3.576 + 1.19 = 4.77\text{ in.}^2 \quad (\text{five no. 9 bars})$$

3. Check if compression steel yields by Eq. 3.46 Compression steel yields if

$$\rho - \rho' \geq K = 0.85\beta_1 \frac{f'_c}{f_y} \left( \frac{d'}{d} \right) \left( \frac{87}{87 - f_y} \right)$$

$$K = (0.85)^2 \left( \frac{4}{60} \right) \left( \frac{2.5}{16.5} \right) \left( \frac{87}{27} \right) = 0.0235$$



**Figure 4.6** Example 4.6.

$$\rho - \rho' = \frac{A_{s1}}{bd} = \frac{3.576}{(12)(16.5)} = 0.01806 \leq K$$

Therefore, compression steel does not yield:  $f'_s < f_y$ .

4. Calculate  $f'_s$ :  $f'_s = 87[(c - d')/c] \leq f_y$ . Determine  $c$  from  $A_{s1}$ :  $A_{s1} = 3.576 \text{ in.}^2$ ,

$$a = \frac{A_{s1}f_y}{0.85f'_c b} = \frac{3.576 \times 60}{0.85 \times 4 \times 12} = 5.26 \text{ in.}$$

$$c = \frac{a}{\beta_1} = \frac{5.26}{0.85} = 6.19 \text{ in.}$$

$$f'_s = 87 \times \left( \frac{6.19 - 2.5}{6.19} \right) = 51.8 \text{ ksi} < 60 \text{ ksi}$$

5. Calculate  $A'_s$  from  $M_{u2} = \phi A'_s f'_s (d - d')$ :

$$902 = 0.9A'_s(51.8)(16.5 - 2.5)$$

Thus,  $A'_s = 1.38 \text{ in.}^2$ , or calculate  $A'_s$  from  $A'_s = A_{s2}(f_y/f'_s) = 1.38 \text{ in.}^2$  (two no. 8 bars). Note that the condition  $[\rho - \rho'(f'_s/f_y)] = (\rho - \rho') \leq \rho_{\max}$  is already met:

$$\left( \rho - \rho' \frac{f'_s}{f_y} \right) = \frac{1}{bd} (A_s - A_{s2}) = \frac{3.576}{12 \times 16.5} = 0.01806$$

as assumed in the solution.

6. These calculations using  $\rho_{\max}$  and  $R_u$  are based on a strain of 0.005 at the centroid of the tension steel:

$$\epsilon_t (\text{at bottom row}) = \left( \frac{d_t - c}{c} \right) 0.003$$

$$d_t = 20 - 2.5 = 17.5 \text{ in.} \quad \epsilon_t = \left( \frac{17.5 - 6.19}{6.19} \right) 0.003 = 0.00548 > 0.005$$

as expected.

### Solution 2

Assuming two rows of tension bars and a strain at the lower row,  $\epsilon_t = 0.005$ , the solution will be as follows:

1. Calculate  $d_t = 20 - 2.5 = 17.5 \text{ in.}$  From the strain diagram,

$$\frac{c}{d_t} = \frac{0.003}{0.003 + \epsilon_t} = \frac{0.003}{0.008} = 0.375$$

$$c = 0.375(17.5) = 6.5625 \text{ in.} \quad a = 0.85c = 5.578 \text{ in.}$$

2. The compression force in the concrete =  $C_1 = 0.85 f'_c ab$ ,

$$C_1 = 0.85(4)(5.578)(12) = 227.6 \text{ K} = T_1 (\text{as singly reinforced})$$

$$A_{s1} = \frac{C_1}{f_y} = \frac{T_1}{f_y} = \frac{227.6}{60} = 3.793 \text{ in.}^2$$

$$d = 20 - 3.5 = 16.5 \text{ in.}$$

$$M_{u1} = \phi A_{s1} f_y \left( d - \frac{a}{2} \right) = 0.9(3.793)(60) \left( 16.5 - \frac{5.578}{2} \right) = 2808 \text{ K} \cdot \text{in.}$$

$$= 234 \text{ K} \cdot \text{ft}$$

$$R_{u1} = \frac{M_{u1}}{bd^2} = \frac{2808.3}{12(16.5)^2} = 0.86 \text{ ksi} = 860 \text{ psi}$$

$$\rho_1 = \frac{A_{s1}}{bd} = 0.01916$$

3. Since  $M_u = 3581 \text{ K} \cdot \text{in.} > M_{u1}$ , compression steel is needed:

$$M_{u2} = 3581 - 2808 = 773 \text{ K} \cdot \text{in.}$$

$$M_{u2} = 0.9A_{s2}f_y(d - d')$$

$$773 = 0.9A_{s2}(60)(16.5 - 2.5) \quad A_{s2} = 1.022 \text{ in.}^2$$

$$\text{Total } A_s = A_{s1} + A_{s2} = 3.793 + 1.022 = 4.815 \text{ in.}^2$$

Use five no. 9 bars.

4. Check if compression steel yields as in step 3 in the first solution:

$$K = 0.0235(\rho - \rho') = \rho_1 = 0.01916 < K$$

Compression steel does not yield:

$$f'_s = 87 \left( \frac{c - d'}{c} \right) = \left( \frac{6.56 - 2.5}{6.56} \right) 87 = 53.84 \text{ ksi}$$

Calculate  $A_{s2}$ :

$$M_{u2} = \phi A'_s f'_s (d - d')$$

$$773 = 0.9A'_s(53.84)(16.5 - 2.5) \quad A'_s = 1.14 \text{ in.}^2$$

Use two no. 7 bars ( $A'_s = 1.2 \text{ in.}^2$ ).

5. Check the design moment strength:

$$A_s = 5.0 \text{ in.}^2 \quad A'_s = 1.2 \text{ in.}^2 \quad A_{s1} = (A_s - A'_s) = 3.8 \text{ in.}^2$$

$$\begin{aligned} \phi M_n &= \phi \left[ A_{s1} f_y \left( d - \frac{a}{2} \right) + A'_s f'_s (d - d') \right] \\ &= 0.9 \left[ 3.8(60) \left( 16.5 - \frac{5.578}{2} \right) + 1.2(53.84)(16.5 - 2.5) \right] \\ &= 3627.6 \text{ K} \cdot \text{in.} = 302.3 \text{ K} \cdot \text{ft} \end{aligned}$$

which is adequate. Note that the strain  $\epsilon_s$  at the centroid level of the tension steel is less than 0.005:

$$\epsilon_s = \left( \frac{d - c}{c} \right) 0.003 = \left( \frac{16.5 - 6.56}{6.56} \right) 0.003 = 0.004546$$

Both solutions are adequate.

### Discussion

1. In the first solution, the net tensile strain  $\epsilon_t = 0.005$  was assumed at the centroid of the tension steel. In this case  $\rho_{\max}$  and  $R_{u, \max}$  can be determined from Table 4.1 or tables in Appendix A. The strain in the lower row of bars will always be greater than 0.005, which meets the ACI Code requirement.
2. In the second solution, the strain limit  $\epsilon_t = 0.005$  is assumed at the lower row. In this case, the strain at the centroid of the two rows of bars will be less than 0.005 and its value depends on the depth of the section. Moreover,  $\rho$  and  $R_u$  for this case are not known and their values depend on the effective depth  $d$ .

3. Comparing the two solutions, the neutral axis depth,  $C_1$ , in solution 1 is slightly smaller than  $c_2$  for the second solution because of the strain limitations, producing a smaller  $A_{s1}$  and then higher  $A_{s2}$ . Total  $A_s$  will normally be very close. It is clear that solution 1 is easier to use because of the use of tables.
4. Note that solution 1 can have the same results as solution 2 by calculating  $A_{s1}$  as follows:  $A_{s1} = \rho_{\max} b d_t = 0.01806 (12 \times 17.5) = 3.793 \text{ in.}^2$ , which is the same  $A_{s1}$  calculated in solution 2, producing  $\epsilon_t = 0.005$  at the lower row of bars.

## 4.5 DESIGN OF T-SECTIONS

In slab–beam–girder construction, the slab dimensions as well as the spacing and position of beams are established first. The next step is to design the supporting beams, namely, the dimensions of the web and the steel reinforcement. Referring to the analysis of the T-section in the previous chapter, we can see that a large area of the compression flange, forming a part of the slab, is effective in resisting a great part or all of the compression force due to bending. If the section is designed on this basis, the depth of the web will be small; consequently, the moment arm is small, resulting in a large amount of tension steel, which is not favorable. Shear requirements should be met, and this usually requires quite a deep section.

In many cases web dimensions can be known based on the flexural design of the section at the support in a continuous beam. The section at the support is subjected to a negative moment, the slab being under tension and considered not effective, and the beam width is that of the web.

In the design of a T-section for a given factored moment,  $M_u$ , the flange thickness,  $t$ , and width,  $b$ , would have been already established from the design of the slab and the ACI Code limitations for the effective flange width,  $b$ , as given in the previous chapter Section 3.15.2. The web thickness,  $b_w$ , can be assumed to vary between 8 and 20 in., with a practical width of 12 to 16 in. Two more unknowns still need to be determined,  $d$  and  $A_s$ . Knowing that  $M_u$ ,  $f'_c$ , and  $f_y$  are always given, two cases may develop as follows:

1. When  $d$  is given and we must calculate  $A_s$ :
  - a. Check if the section acts as a rectangular or T-section by assuming  $a = t$  and calculating the moment strength of the whole flange:

$$\phi M_{\text{nf}}(\text{flange}) = \phi(0.85f'_c)bt \left( d - \frac{1}{2}t \right) \quad (4.7)$$

If  $M_u > \phi M_{\text{nf}}$ , then  $a > t$ . If  $M_u < \phi M_{\text{nf}}$ , then  $a < t$ , and the section behaves as a rectangular section.

- b. If  $a < t$ , then calculate  $\rho$  using Eq. 4.2, and  $A_s = \rho b d$ . Check that  $\rho_w \geq \rho_{\min}$ .
  - c. If  $a > t$ , determine  $A_{\text{sf}}$  for the overhanging portions of the flange, as explained in Section 3.15.4:

$$A_{\text{sf}} = \frac{0.85f'_c(b - b_w)t}{f_y} \quad (4.8)$$

$$M_{u2} = \phi A_{\text{sf}} f_y \left( d - \frac{1}{2}t \right) \quad (4.9)$$

The moment resisted by the web is

$$M_{u1} = M_u - M_{u2}$$

Calculate  $\rho_1$  using  $M_{u1}$ ,  $b_w$ , and  $d$  in Eq. 4.2 and determine  $A_{s1} = \rho_1 b_w d$ :

$$\text{Total } A_s = A_{s1} + A_{sf}$$

Then check that  $A_s \leq A_{s, \max}$ , as explained in Section 3.15. Also check that  $\rho_w = A_s / (b_w d) \geq \rho_{\min}$ .

- d. If  $a = t$ , then  $A_s = \phi(0.85f'_c)bt/f_y$ .
2. When  $d$  and  $A_s$  are not known, the design may proceed as follows:
- a. Assume  $a = t$  and calculate the amount of total steel,  $A_{sft}$ , needed to resist the compression force in the whole flange,  $bt$ :

$$A_{sft} = \frac{(0.85f'_c)bt}{f_y} \quad (4.10)$$

- b. Calculate  $d$  based on  $A_{sft}$  and  $a = t$  from the equation

$$M_u = \phi A_{sft} f_y \left( d - \frac{1}{2}t \right) \quad (4.11)$$

If the depth,  $d$ , is acceptable, then  $A_s = A_{sft}$  and  $h = d + 2.5$  in. for one row of bars or  $h = d + 3.5$  in. for two rows of bars.

- c. If a new  $d_1$  is adopted greater than the calculated  $d$ , then the section behaves as a rectangular section, and  $\rho$  can be calculated using Eq. 4.2;  $A_s = \rho b d < A_{sft}$ .
- d. If a new  $d_2$  is adopted that is smaller than the calculated  $d$ , then the section will act as a T-section, and the final  $A_s$  will be greater than  $A_{sft}$ . In this case, proceed as in step 1(c) to calculate  $A_s$ .

#### Example 4.7

The T-beam section shown in Fig. 4.7 has a web width,  $b_w$ , of 10 in., a flange width,  $b$ , of 40 in., a flange thickness of 4 in., and an effective depth,  $d$ , of 14.5 in. Determine the necessary reinforcement if the applied factored moment is 3350 K·in. Given:  $f'_c = 3$  ksi and  $f_y = 60$  ksi.

#### Solution

1. Check the position of the neutral axis; the section may be rectangular. Assume the depth of compression block  $a$  is 4 in.; that is,  $a = t = 4$  in. Then

$$\phi M_n = \phi(0.85f'_c)bt \left( d - \frac{1}{2}t \right) = 4590 \text{ K} \cdot \text{in.} > M_u = 3350 \text{ K} \cdot \text{in.}$$

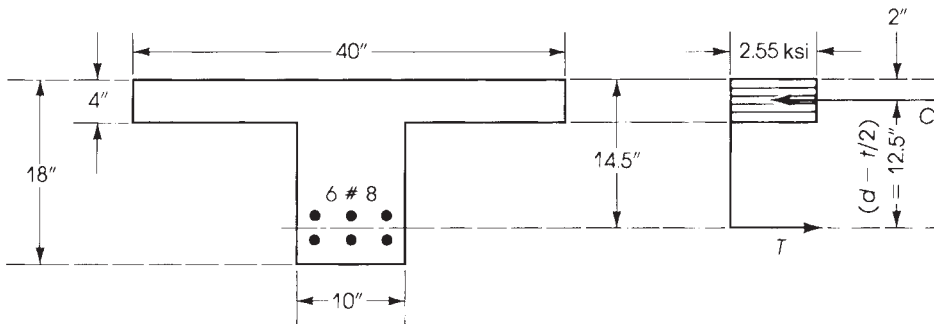


Figure 4.7 Example 4.7: T-section.

The design moment that the concrete flange can resist is greater than the factored applied moment. Therefore, the section behaves as a rectangular section.

2. Determine the area of tension steel, considering a rectangular section,  $b = 40$  in.:

$$R_u = \frac{\phi M_n}{bd^2} = \frac{3,350,000}{40 \times 14.5^2} = 398 \text{ psi}$$

From Eq. 4.2 or from tables in Appendix A, for  $R_u = 398$  psi and  $\rho = 0.00817$ ,

$$A_s = \rho bd = 0.00817 \times 40 \times 14.5 = 4.74 \text{ in.}^2$$

Use six no. 8 bars,  $A_s = 4.74 \text{ in.}^2$  (in two rows).

3. Check that  $\rho_w = A_s/b_w d \geq \rho_{\min}$ ;  $\rho_w = 4.74/(10 \times 14.5) = 0.0327 > \rho_{\min} = 0.00333$ . Note that the  $A_s$  used is less than  $A_{s, \max}$  of  $7.06 \text{ in.}^2$  calculated by Eq. 3.72.  
Also,  $a = 2.788$  in.,  $c = 3.28$  in.,  $d_t = 14.5$  in.,  
and  $\epsilon_t = 0.003(d_t - c)/c = 0.01 > 0.005$ , which is OK.

### Example 4.8

The floor system shown in Fig. 4.8 consists of 3-in. slabs supported by 14-ft-span beams spaced 10 ft on center. The beams have a web width,  $b_w$ , of 14 in. and an effective depth,  $d$ , of 18.5 in. Calculate the necessary reinforcement for a typical interior beam if the factored applied moment is  $5080 \text{ K} \cdot \text{in}$ . Use  $f'_c = 3 \text{ ksi}$  and  $f_y = 60 \text{ ksi}$ .

### Solution

1. Find the beam flange width: The flange width is the smallest of

$$b = 16t + b_w = 3 \times 16 + 12 = 60 \text{ in.}$$

and

$$b = \frac{\text{span}}{4} = \frac{14 \times 12}{4} = 42 \text{ in.}$$

Center-to-center spacing of adjacent slabs is  $10 \times 12 = 120$  in. Use  $b = 42$  in.

2. Check the position of the neutral axis assuming  $a = t$ :

$$\begin{aligned} \phi M_n (\text{based on flange}) &= \phi \times 0.85f'_c b t \left( d - \frac{1}{2}t \right) \\ &= 0.9 \times 0.85 \times 3 \times 42 \times 3(18.5 - 1.5) = 4916 \text{ K} \cdot \text{in.} \end{aligned}$$

The applied moment is  $M_u = 5080 \text{ K} \cdot \text{in.} > 4916 \text{ K} \cdot \text{in.}$ ; the beam acts as a T-section, so  $a > t$ .

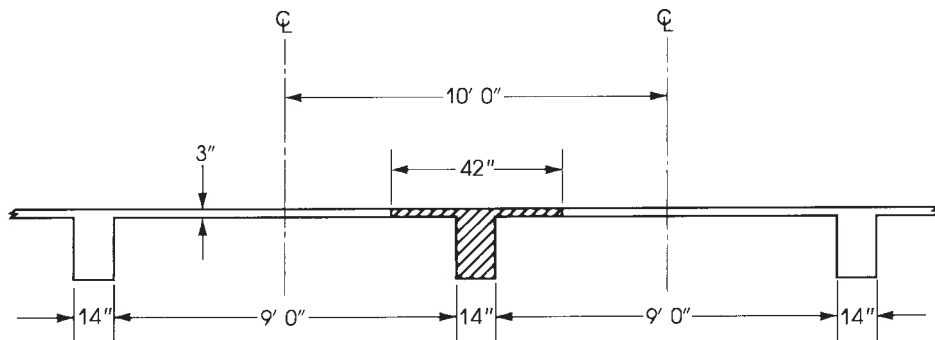


Figure 4.8 Example 4.8: Effective flange width.

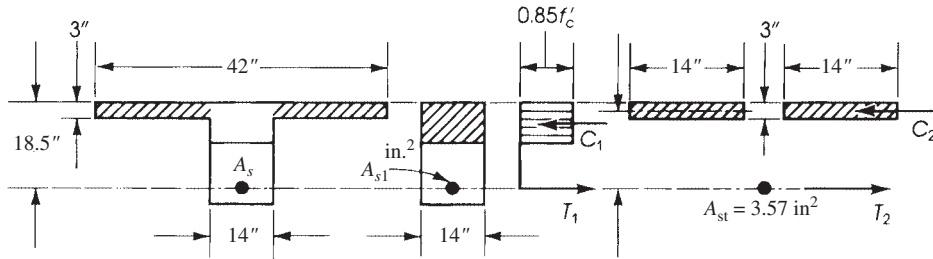


Figure 4.9 Analysis of Example 4.8.

3. Find the portion of the design moment taken by the overhanging portions of the flange (Fig. 4.9). First calculate the area of steel required to develop a tension force balancing the compressive force in the projecting portions of the flange:

$$A_{sf} = \frac{0.85f'_c(b - b_w)t}{f_y} = \frac{0.85 \times 3 \times (42 - 14) \times 3}{60} = 3.57 \text{ in}^2.$$

Here,  $\phi M_n = M_{u1} + M_{u2}$ , that is, the sum of the design moment of the web and the design moment of the flanges:

$$\begin{aligned} M_{u2} &= \phi A_{sf} f_y \left( d - \frac{1}{2} t \right) \\ &= 0.9 \times 3.57 \times 60 \left( 18.5 - \frac{3}{2} \right) = 3277 \text{ K} \cdot \text{in}. \end{aligned}$$

4. Calculate the design moment of the web (as a singly reinforced rectangular section):

$$M_{u1} = M_u - M_{u2} = 5080 - 3277 = 1803 \text{ K} \cdot \text{in}.$$

$$R_u = \frac{M_{u1}}{(b_w d^2)} = \frac{1,803,000}{14 \times (18.5)^2} = 376 \text{ psi}$$

From Eq. 4.2 or the tables in Appendix A, for  $R_u = 376$  psi,  $\rho_1 = 0.0077$ :

$$A_{s1} = \rho_1 b_w d = 0.0077(14)(18.5) = 1.99 \text{ in}^2$$

$$\text{Total } A_s = A_{sf} + A_{s1} = 3.57 + 1.99 = 5.56 \text{ in}^2 \quad (\text{uses ix no.9 bars in two rows})$$

Total  $h_5 = 18.5 + 3.5 = 22$  in. Calculate  $A_{s, \max}$  for T-sections using Eq. 3.72:

$$\text{Max } A_s = 7.02 \text{ in}^2 > 5.56 \text{ in}^2$$

5. Check  $\epsilon_t$ :  $a = 1.99 \times 60 / (0.85 \times 3 \times 14) = 3.34$  in.,  $c = 3.93$  in., and  $d_t = 19.5$  in. Then  $\epsilon_t = 0.003$  ( $(d_t - c)/c = 0.0119 > 0.005$ , tension-controlled section ( $\phi = 0.9$ )).

### Example 4.9

In a slab-beam system, the flange width was determined to be 48 in., the web width was  $b_w = 16$  in., and the slab thickness was  $t = 4$  in. (Fig. 4.10). Design a T-section to resist an external factored moment of  $M_u = 812$  K · ft. Use  $f'_c = 3$  ksi and  $f_y = 60$  ksi.

### Solution

1. Because the effective depth is not given, let  $a = t$  and calculate  $A_{sft}$  for the whole flange:

$$A_{sft} = \frac{0.85f'_c b t}{f_y} = \frac{0.85(3)(48)(4)}{60} = 8.16 \text{ in}^2$$



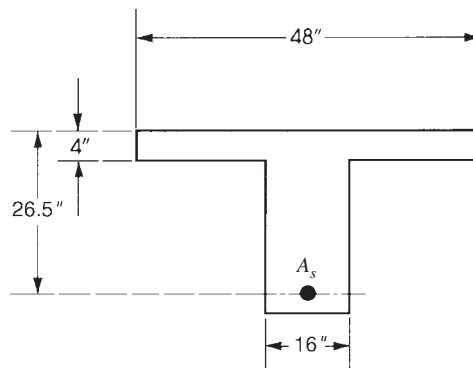


Figure 4.10 Example 4.9.

Let  $M_u = \phi A_{sft} f_y (d - t/2)$  and calculate  $d$ :

$$812 \times 12 = 0.9(8.16)(60) \left( d - \frac{4}{2} \right) \quad d = 24.1 \text{ in.}$$

Now, if an effective  $d = 24.1$  in. is chosen, then  $A_s = A_{sft} = 8.16 \text{ in.}^2$

- If a depth  $d > 24.1$  in. is chosen, say 26.5 in., then  $a < t$  and it is a rectangular analysis. The steel ratio can be calculated from Eq. 4.2 with  $\rho = 0.00574$  and  $A_s = \rho b d = 0.00574 \times 48 \times 26.5 = 7.3 \text{ in.}^2$  (six no. 10 bars in two rows,  $A_s = 7.62 \text{ in.}^2$ ).
- If a depth  $d < 24.1$  in. is chosen, say, 23.5 in., then  $a > t$ , and the section behaves as a T-section. Calculate

$$A_{sf} = \frac{0.85 f'_c t (b - b_w)}{f_y} = \frac{0.85(3)(4)(48 - 16)}{60} = 5.44 \text{ in.}^2$$

$$M_{u2} = \phi A_{sf} f_y \left( d - \frac{1}{2} t \right) = 0.9(5.44)(60) \left( 23.5 - \frac{4}{2} \right) = 6316 \text{ K} \cdot \text{in.}$$

$$M_{u1} = 812 \times 12 - 6316 = 3428 \text{ K} \cdot \text{in.}$$

- For the basic singly reinforced section,  $b_w = 16$  in.,  $d = 23.5$  in., and  $M_{u1} = 3428 \text{ K} \cdot \text{in.}$ ,  $R_u = 387$  psi. Calculate  $\rho_1$  from Eq. 4.2 to get  $\rho_1 = 0.0079$ :

$$A_{s1} = \rho_1 b_w d = 0.0079(16)(23.5) = 2.97 \text{ in.}^2$$

Total  $A_s = A_{sf} + A_{s1} = 5.44 + 2.97 = 8.41 \text{ in.}^2$  (seven no.10 bars in two rows,

$$A_s = 8.89 \text{ in.}^2)$$

- Check  $\epsilon_t$ :  $a = 2.97 \times 60 / (0.85 \times 3 \times 16) = 4.368$  in.,  $c = a / 0.85 = 5.14$  in.,  $d_t = 24.5$  in., and  $\epsilon_t = 0.003 (d_t - c) / c = 0.0113 > 0.005$ , a tension-controlled section.
- Calculate the total max  $A_s$  that can be used for the T-section by Eq. 3:

$$\text{Max } A_s =$$

$$= 0.0425[(b - b_w)t + 0.319bwd] = 10.54 \text{ in.}^2$$

$$A_s(\text{used}) \leq \text{max } A_s$$

- Note:* If there are no restrictions on the total depth of the beam, it is a common practice to adopt the case when  $a \leq t$  (step 2). This is because an increase in  $d$  produces a small increase in concrete in the web only while decreasing the quantity of  $A_s$  required.

## 4.6 ADDITIONAL EXAMPLES

The following design examples give some practical applications and combine structural analysis with concrete design of beams and frames.

**Example 4.10**

For the precast concrete I-section shown in Fig. 4.11, calculate the reinforcement needed to support a factored moment of 360 K·ft. Use  $f'_c = 4$  ksi and  $f_y = 60$  ksi.

**Solution**

Determine if the force in the flange area  $14 \times 5$  in. will be sufficient to resist a factored moment of 360 K·ft. Let  $d = 23.5$  in. Force in flange ( $C_c$ ) =  $0.85 \times f'_c$  (flange area) =  $0.85 \times 4 \times (14 \times 5) = 238$  K located at 2.5 in. from the top fibers and  $a = 5$  in.:

$$\phi M_n = 0.9 C_c \left( d - \frac{a}{2} \right) = 0.9 \times 238 \frac{23.5 - 2.5}{12} = 374.9 \text{ K} \cdot \text{ft}$$

which is greater than the applied moment of 360 K·ft. Therefore,  $a < 5$  in.:

$$\phi M_n = \phi A_s f_y \left( d - \frac{1}{2} a \right)$$

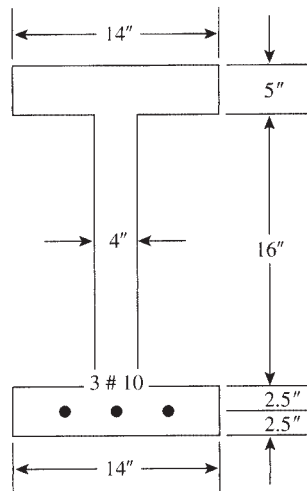
$$360 \times 12 = 0.9 A_s (60) \left( 23.5 - \frac{60 A_s}{1.7 \times 14 \times 14} \right)$$

where

$$a = \frac{A_s f_y}{0.85 f'_c b}$$

Solve to get  $A_s = 3.79 \text{ in.}^2$ . Or use Eq. 4.2 to get  $\rho = 0.01152$  and  $A_s = 0.01152 \times 14 \times 23.5 = 3.79 \text{ in.}^2$ . Use three no. 10 bars in one row, as shown in Fig. 4.11.

For similar T-sections or I-sections, it is better to adopt a section with a flange size to accommodate the compression force,  $C_c$ . In this case,  $a$  is less than or equal to the flange depth. The bottom flange is in tension and not effective.



**Figure 4.11** Example 4.10.

**Example 4.11**

The simply supported beam shown in Fig. 4.12 carries a uniform dead load of 2.8 K/ft (including self-weight) in addition to a service load of 1.6 K/ft. Also, the beam supports a concentrated dead load of 16 K and a concentrated live load of 7 K at C, 10 ft from support A.

- Determine the maximum factored moment and its location on the beam.
- Design a rectangular section to carry the loads safely using a steel percentage of about 1.5%,  $b = 20$  in.,  $f'_c = 4$  ksi, and  $f_y = 60$  ksi.

**Solution**

- Calculate the uniform factored load:  $w_u = 1.2(2.8) + 1.6(1.6) = 5.91$  K/ft. Calculate the concentrated factored load:  $P_u = 1.2(16) + 1.6(7) = 30.4$  K. Calculate the reaction at A by taking moments about B:

$$R_A = 5.91(30) \frac{30/2}{30} + \frac{30.4(20)}{30} = 108.92 \text{ K}$$

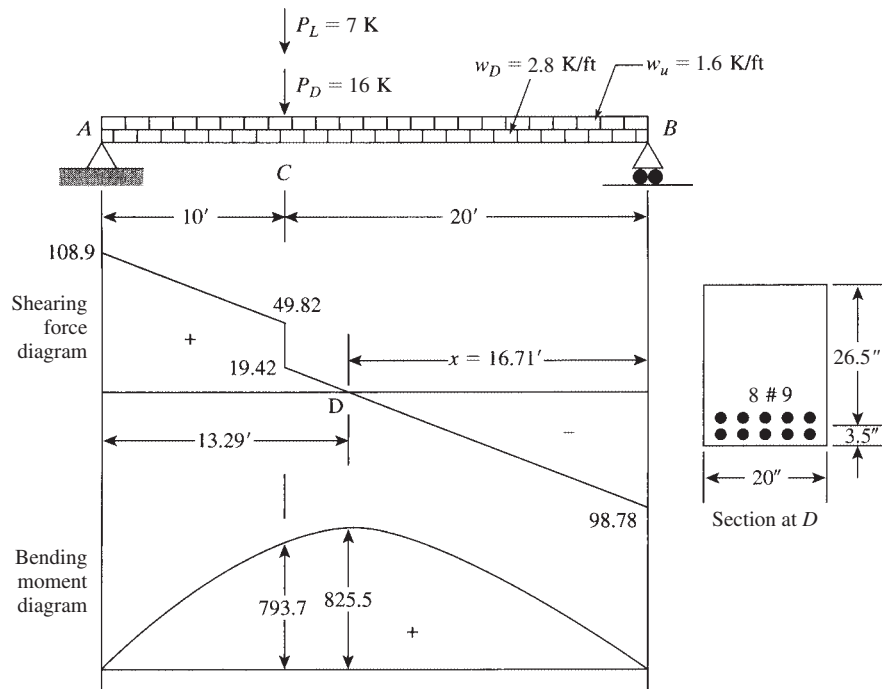
$$R_B = 5.91(30) + 30.4 - 108.92 = 98.78 \text{ K}$$

Maximum moment in the beam occurs at zero shear. Starting from B,

$$V = 0 = 98.78 - 5.91x \quad \text{and} \quad x = 16.71 \text{ ft from B at D}$$

$$M_u(\text{at D}) = 98.72(16.71) - 5.91(16.71) \left( \frac{16.71}{2} \right) = 825.5 \text{ K} \cdot \text{ft} \quad (\text{design moment})$$

$$M_u(\text{at C}) = 98.78(20) - 5.91(20) \left( \frac{20}{2} \right) = 793.6 \text{ K} \cdot \text{ft}$$



**Figure 4.12** Example 4.11.

- b. Design of the section at  $D$ : For  $f'_c = 4$  ksi and  $f_y = 60$  ksi,  $\rho_{\max} = 0.01806$  and  $\rho_{\min} = 0.00333$ , and the design steel ratio of 1.5% is within the limits. For  $\rho = 0.015$ ,  $R_u = 700$  psi (from Table A.2) or from Eq. 3.22:

$$M_u = R_u b d^2 \quad \text{or} \quad 825.5 \times 12 = 0.7(20)d^2$$

Solve to get  $d = 26.6$  in.:

$$A_s = 0.015 \times 20 \times 26.6 = 7.98 \text{ in.}^2$$

Choose eight no. 9 bars in two rows (area  $8 \text{ in.}^2$ ), five in the lower row plus three in the upper row. Minimum  $b$  for five no. 9 bars in one row is 14 in. (Table A.7). Total depth  $h = 26.6 + 3.5 = 30.1$  in. Use  $h = 30$  in. Actual  $d = 30 - 3.5 = 26.5$  in. Check the moment capacity of the section,  $a = 8 \times 60 / (0.85 \times 4 \times 20) = 7.06$  in.:

$$\phi M_n = 0.9 \times 8 \times 60 \frac{26.5 - 7.06/2}{12} = 826.9 \text{ K} \cdot \text{ft}$$

which is greater than  $825.5 \text{ K} \cdot \text{ft}$ . Check that  $A_s = 8 \text{ in.}^2$  is less than  $A_{s, \max}$ :

$$A_{s, \max} = 0.01806 \times 20 \times 26.5 = 9.57 \text{ in.}^2$$

which exceeds  $8 \text{ in.}^2$ . The final section is shown in Fig. 4.12.

#### Example 4.12

The two-hinged frame shown in Fig. 4.13 carries a uniform service dead load (including estimated self-weight) of 2.33 K/ft and a uniform service live load of 1.5 K/ft on frame beam  $BC$ . The moment at the corner  $B$  (or  $C$ ) can be evaluated for this frame dimension,  $M_b = M_c = -wL^2/18.4$ , and the reaction at  $A$  or  $D$  equals  $wL/2$ . A typical section of beam  $BC$  is shown; the column section is  $16 \times 21$  in. It is required to:

- Draw the bending moment and shear diagrams for the frame  $ABCD$  showing all critical values.
- Design the beam  $BC$  for the factored moments, positive and negative, using  $f'_c = 4$  ksi and  $f_y = 60$  ksi. Show reinforcement details.

#### Solution

- Calculate the forces acting on the frame using a computer program or the values mentioned previously.

Factored load ( $w_u$ ) =  $1.2(2.33) + 1.6(1.5) = 5.2$  K/ft.

Because of symmetry  $M_B = M_C = -wL^2/18.4 = -5.2(40)^2/18.4 = -452.2 \text{ K} \cdot \text{ft}$ .

Positive moment at midspan ( $E$ ) =  $w_u L^2/8 + M_B = 5.2(40)^2/8 - 452.2 = 587.8 \text{ K} \cdot \text{ft}$ .

Vertical reaction at  $A = R_A = R_D = w_u L/2 = 5.2(40)/2 = 104$  K. Horizontal reaction at  $A = H_A = M_B/h = 452.2/16 = 28.26$  K.

The moment and shear diagrams are shown in Fig. 4.13.

Determine the location of zero moment at section F on beam  $BC$  by taking moments about F:

$$104(y) - 28.26(16) - 5.2(y)^2/2 = 0 \quad y = 4.963 \text{ ft} \quad \text{say, 5 ft from joint } B$$

- Design of beam  $BC$ :

- Design of section  $E$  at midspan:  $M_u = +587.8 \text{ K} \cdot \text{ft}$ . Assuming two rows of bars,  $d = 21 - 3.5 = 17.5$  in. Calculate the moment capacity of the flange using  $a = 5.0$  in.:

$$\phi M_n (\text{flange}) = \phi(0.85f'_c)ab \left( d - \frac{5}{2} \right)$$

$$= 0.9(0.85 \times 4) \times (5 \times 60) \times \frac{17.5 - 2.5}{12} = 1147.5 \text{ K} \cdot \text{ft}$$

which is greater than the applied moment; therefore,  $a < 5.0$  in.

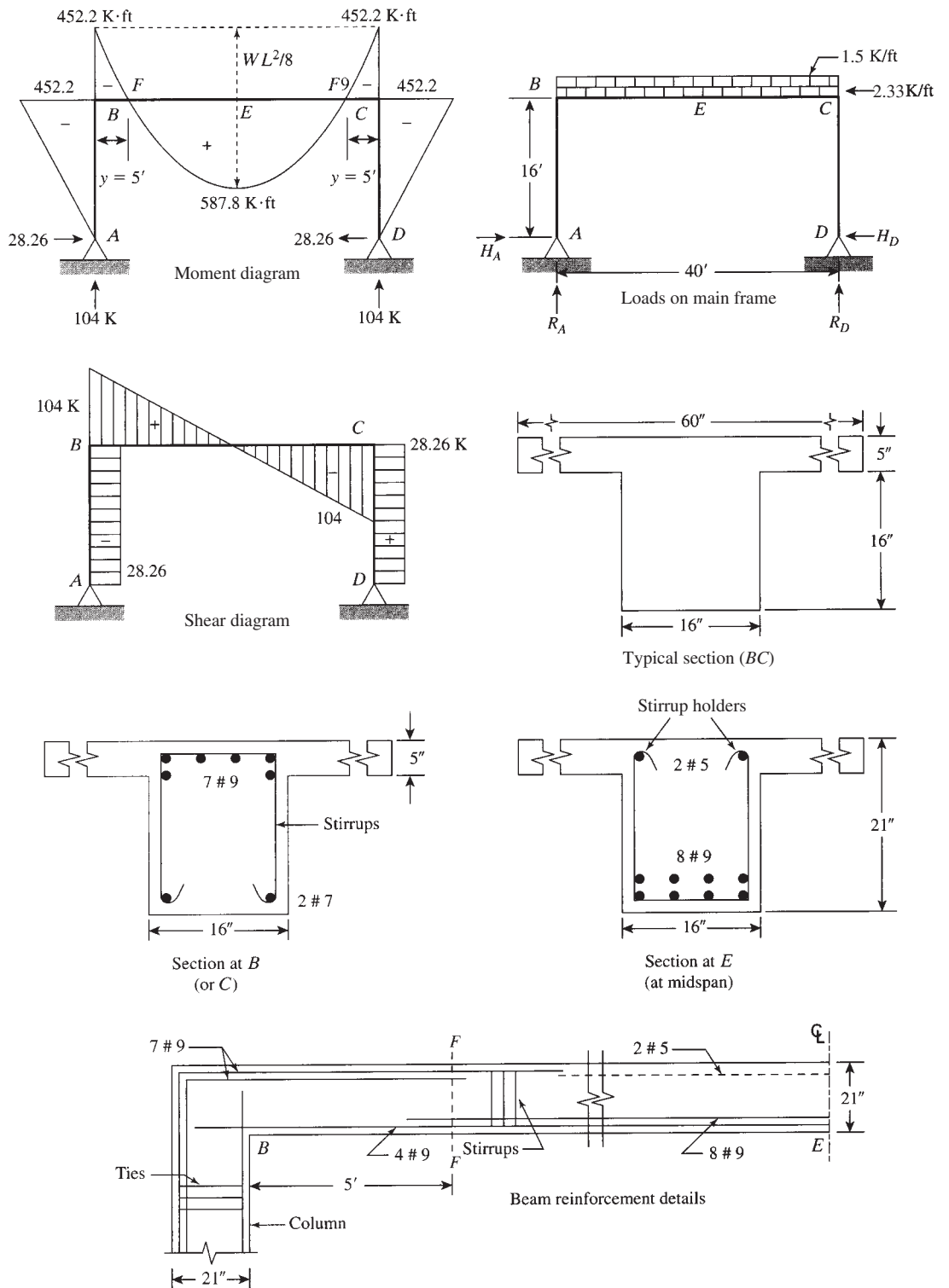


Figure 4.13 Example 4.12.

Assume  $a = 2.0$  in. and calculate  $A_s$ :

$$M_u = \phi A_s f_y \left( d - \frac{a}{2} \right)$$

$$587.8 \times 12 = 0.9 \times 60 A_s (17.5 - 1.0) \quad \text{and} \quad A_s = 7.92 \text{ in.}^2$$

Check assumed  $a = A_s f_y / (0.85 f'_c b) = 7.92 \times 60 / (0.85 \times 4 \times 60) = 2.33$  in. Revised  $A_s = 587.8 \times 12 / (0.9 \times 60 \times 16.33) = 7.99 \text{ in.}^2$  Check revised  $a$ :  $a = 7.99 \times 2.33 / 7.92 = 2.35$  in., which is very close to 2.33 in.

Alternatively, Eq. 4.2 can be used to get  $\rho$  and  $A_s$ . Choose eight no. 9 bars in two rows (area =  $8.0 \text{ in.}^2$ ), ( $b_{\min} = 11.8$  in.). Extend four no. 9 bars on both sides to the columns. The other four bars can terminate where they are not needed, beyond section F; see the longitudinal section in Fig. 4.13.

2. Design of section at B:  $M_u = -452.2$  K·ft. The section acts as a rectangular section,  $b = 16$  in. and  $d = 17.5$  in. The main tension reinforcement lies in the flange:

$$\rho_{\max} = 0.01806 \quad \text{and} \quad R_{u,\max} = 820 \text{ psi} \quad (\text{Table 4.1})$$

Check the maximum moment capacity of the section as singly reinforced:

$$\phi M_{n,\max} = R_{u,\max} b d^2 = \frac{0.82(16)(17.5)^2}{12} = 334.8 \text{ K} \cdot \text{ft}$$

which is less than the applied moment. Compression steel is needed:

$$A_{s1} = 0.01806(16)(17.5) = 5.06 \text{ in.}^2$$

$$M_{u2} = 452.2 - 334.8 = 117.4 \text{ K} \cdot \text{ft}$$

$$M_{u2} = \phi A_{s2} f_y (d - d')$$

$$\text{Assumed } d' = 2.5 \text{ in.}$$

$$117.4 \times 12 = 0.9 A_{s2} (60)(17.5 - 2.5) \quad \text{and} \quad A_{s2} = 1.74 \text{ in.}^2$$

Total tension steel =  $5.06 + 1.74 = 6.8 \text{ in.}^2$  Use seven no. 9 bars in two rows (area used  $7.0 \text{ in.}^2$ , which is adequate). For compression steel, use two no. 9 bars (area  $2.0 \text{ in.}^2$ ), extended from the positive-moment reinforcement to the column. Actually, four no. 9 bars are available; see the longitudinal section in Fig. 4.13.

The seven no. 9 bars must extend in the beam  $BC$  beyond section  $F$  into the compression zone and also must extend into the column  $BA$  to resist the column moment of  $452.2 \text{ K} \cdot \text{ft}$  without any splices at joints  $B$  or  $C$ .

Check if compression steel yields by using Eq. 3 or Table 3. Assume  $K = 0.01552$  ( $d'/d = 0.1552(2.5)/(17.5) = 0.02217 > \rho_1 = 0.01806$ ). Therefore, compression steel yields, and  $f'_s = 60$  ksi, as assumed.

Stirrups are shown in the beam to resist shear (refer to Chapter 8), and two no. 5 bars were placed at the top of the beam to hold the stirrups in position. Ties are used in the column to hold the vertical bars (refer to Chapter 10). To determine the extension of the development length of bars in beams or columns, refer to Chapter 7.

## 4.7 EXAMPLES USING SI UNITS

### Example 4.13

Design a singly reinforced rectangular section to resist a factored moment of  $280 \text{ kN} \cdot \text{m}$  using the maximum steel percentage for tension-controlled sections. Given:  $f'_c = 20 \text{ N/mm}^2$ ,  $f_y = 400 \text{ N/mm}^2$ , and  $b = 250 \text{ mm}$ .

**Solution**

$$\begin{aligned}\rho_b &= (0.85)\beta_1 \left[ \frac{f'_c}{f_y} \right] \left( \frac{600}{600 + f_y} \right) \\ &= 0.85 \times 0.85 \times \frac{20}{400} \times \left( \frac{600}{600 + 400} \right) = 0.0217 \\ \rho_{\max} &= \left( \frac{0.003 + f_y/E_s}{0.008} \right) \rho_b \quad E_s = 200,000 \text{ MPa} \quad \frac{f_y}{E_s} = 0.002 \\ &= 0.625\rho_b = 0.01356 \\ \phi &= 0.9\end{aligned}$$

$$\begin{aligned}R_{u\max} &= \phi\rho_{\max}f_y \left( 1 - \frac{\rho_{\max}f_y}{1.7f'_c} \right) \\ &= 0.9 \times 0.01356 \times 400 \left( 1 - \frac{0.01356 \times 400}{1.7 \times 20} \right) = 4.1 \text{ N/mm}^2 (\text{MPa})\end{aligned}$$

$$M_u = R_u b d^2$$

$$d = \sqrt{\frac{M_u}{R_u b}} = \sqrt{\frac{280 \times 10^6}{4.1 \times 250}} = 523 \text{ mm}$$

$$A_s = \rho b d = 0.01356 \times 250 \times 523 = 1772 \text{ mm}^2 = 17.72 \text{ cm}^2$$

Choose four bars, 25 mm diameter, in two rows.

Provided  $A_s = 4 \times 4.9 = 19.6 \text{ cm}^2$ . Total depth is

$$\begin{aligned}h &= d + 25 \text{ mm} + 60 \text{ mm} \\ &= 523 + 25 + 60 = 608 \text{ mm say, } 610 \text{ mm (or } 600 \text{ mm)}\end{aligned}$$

Check minimum width:

$$b_{\min} = 2D + 1S + 95 \text{ mm} = 3 \times 25 + 95 = 170 \text{ mm} < 250 \text{ mm}$$

Bars are placed in two rows.

**Example 4.14**

Calculate the required reinforcement for a beam that has a section of  $b = 300 \text{ mm}$  and a total depth  $h = 600 \text{ mm}$  to resist  $M_u = 696 \text{ kN} \cdot \text{m}$ . Given:  $f'_c = 30 \text{ N/mm}^2$  and  $f_y = 420 \text{ N/mm}^2$ .

**Solution**

1. Determine the design moment strength of the section using  $\rho_{\max}$  (for tension-controlled section,  $\phi = 0.9$ ):

$$\begin{aligned}\rho_b &= (0.85)\beta_1 \left[ \frac{f'_c}{f_y} \right] \left( \frac{600}{600 + f_y} \right) \\ &= 0.85 \times 0.85 \times \frac{30}{420} \times \left( \frac{600}{600 + 1020} \right) = 0.0304\end{aligned}$$

$$\rho_{\max} = \left( \frac{0.003 + f_y/E_s}{0.008} \right) \rho_b = 0.6375\rho_b = 0.01938$$

$$\begin{aligned} R_{u\max} &= \phi\rho_{\max}f_y \left( 1 - \frac{\rho_{\max}f_y}{1.7f'_c} \right) \\ &= 0.9 \times 0.01938 \times 420 \left( 1 - \frac{0.01938 \times 420}{1.7 \times 30} \right) = 6.16 \text{ N/mm}^2 (\text{MPa}) \end{aligned}$$

$$d = h - 85 \text{ mm (assuming two rows of bars)}$$

$$= 600 - 85 = 515 \text{ mm}$$

$$\phi M_n = R_u b d^2 = 6.16 \times 300 \times (515)^2 \times 10^{-6} = 490 \text{ kN} \cdot \text{m}$$

This is less than the external moment; therefore, compression reinforcement is needed.

2. Calculate  $A_{s1}$ ,  $M_{u1}$ , and  $M_{u2}$ :

$$A_{s1} = \rho_{\max} b d = 0.01938 \times 300 \times 515 = 2994 \text{ mm}^2$$

$$M_{u2} = M_u - M_{u1} = 696 - 490 = 206 \text{ kN} \cdot \text{m}$$

3. Calculate  $A_{s2}$  and  $A'_s$  due to  $M_{u2}$ . Assume  $d' = 60$  mm:

$$M_{u2} = \phi A_{s2} f_y (d - d')$$

$$206 \times 10^6 = 0.9 A_{s2} \times 420 (515 - 60) \quad A_{s2} = 1198 \text{ mm}^2$$

Total tension steel is  $2994 + 1198 = 4192 \text{ mm}^2$ .

4. Compression steel yields if

$$\rho - \rho' = \rho_1 \geq 0.85\beta_1 \times \frac{f'_c}{f_y} \times \frac{d'}{d} \times \frac{600}{600 - f_y} = K$$

$$K = (0.85)^2 \times \frac{30}{420} \times \frac{60}{515} \times \frac{600}{600 - 420} = 0.020$$

Because  $\rho - \rho' = \rho_{\max} = 0.01938 < 0.020$ , compression steel does not yield.

5. Calculate

$$a = \frac{A_s f_y}{0.85 f'_c b}$$

$$= \frac{2994(420)}{0.85 \times 30 \times 300} = 164.4 \text{ mm}$$

$$c = \frac{a}{0.85} = 193.4 \text{ mm} \quad d' = 60 \text{ mm}$$

$$f'_c = 600 \left( \frac{c - d'}{c} \right) = 414 \text{ N/mm}^2$$

$$A'_s = A_{s2} \left( \frac{420}{414} \right) = 1215 \text{ mm}^2$$

6. Choose steel bars as follows: For tension, choose six bars 30 mm in diameter (30 M). The  $A_s$  provided (4200 mm<sup>2</sup>) is greater than  $A_s$ , as required. For compression steel, choose three bars 25 mm in diameter (25 M) (Table B.11):

$$A'_s = 1500 \text{ mm}^2 > 1215 \text{ mm}^2$$



## SUMMARY

**Sections 4.1–4.3: Design of a Singly Reinforced Rectangular Section**

Given:  $M_u$  (external factored moment),  $f'_c$  (compressive strength of concrete), and  $f_y$  (yield stress of steel).

**Case 1** When  $b$ ,  $d$ , and  $A_s$  (or  $\rho$ ) are *not* given:

1. Assume  $\rho_{\min} \leq \rho \leq \rho_{\max}$ . Choose  $\rho_{\max}$  for a minimum concrete cross section (smallest) or choose  $\rho$  between  $\rho_{\max}/2$  and  $\rho_b/2$  for larger sections. For example, if  $f_y = 60$  ksi, you may choose

$$\rho = 1.2\% \quad R_n = 618 \text{ psi} \quad \text{for } f'_c = 3 \text{ ksi}$$

$$\rho = 1.4\% \quad R_n = 736 \text{ psi} \quad \text{for } f'_c = 4 \text{ ksi}$$

$$\rho = 1.4\% \quad R_n = 757 \text{ psi} \quad \text{for } f'_c = 5 \text{ ksi}$$

For any other value of  $\rho$ ,  $R_n = \rho f_y [1 - (\rho f_y / 1.7 f'_c)]$ , and  $R_u = \phi R_n$ .

2. Calculate  $bd^2 = M_u / \phi R_n$  ( $\phi = 0.9$ ) for tension-controlled sections.
3. Choose  $b$  and  $d$ . The ratio of  $d$  to  $b$  is approximately 1 to 3, or  $d/b \approx 2.0$ .
4. Calculate  $A_s = \rho bd$ ; then choose bars to fit in  $b$  in either one row or two rows. (Check  $b_{\min}$  from the tables.)
5. Calculate

$$h = \begin{cases} d + 2.5 \text{ in.} & \text{(for one row of bars)} \\ d + 3.5 \text{ in.} & \text{(for two rows of bars)} \end{cases}$$

Here,  $b$  and  $h$  must be to the nearest higher inch. *Note:* If  $h$  is increased, calculate new  $d = h - 2.5$  (or 3.5) and recalculate  $A_s$  to get a smaller value.

**Case 2** When  $\rho$  is given,  $d$ ,  $b$ , and  $A_s$  are required. Repeat steps 1 through 5 from Case 1.

**Case 3** When  $b$  and  $d$  (or  $h$ ) are given,  $A_s$  is required.

1. Calculate  $R_n = M_u / \phi bd^2$  ( $\phi = 0.9$ ).
2. Calculate

$$\rho = \left( \frac{0.85 f'_c}{f_y} \right) \left[ 1 - \sqrt{1 - \frac{2R_n}{0.85 f'_c}} \right]$$

(or get  $\rho$  from tables or Eq. 4.2).

3. Calculate  $A_s = \rho bd$ , choose bars, and check  $b_{\min}$ .
4. Calculate  $h$  to the nearest higher inch (see note, Case 1, step 5).

**Case 4** When  $b$  and  $\rho$  are given,  $d$  and  $A_s$  are required.

1. Calculate

$$R_n = \rho f_y \left( 1 - \frac{\rho f_y}{1.7 f'_c} \right) \quad R_u = \phi R_n (\phi = 0.9)$$

2. Calculate

$$d = \sqrt{\frac{M_u}{\phi R_n b}}$$

3. Calculate  $A_s = \rho b d$ , choose bars, and check  $b_{\min}$ .
4. Calculate  $h$  to the nearest higher inch (see note, Case 1, step 5). *Note:* Equations that may be used to check the moment capacity of the section after the final section is chosen are

$$\begin{aligned} M_u &= \phi M_n = \phi A_s f_y \left( d - \frac{A_s f_y}{1.7 f'_c b} \right) = \phi A_s f_y d \left( 1 - \frac{\rho f_y}{1.7 f'_c} \right) \\ &= \phi \rho f_y (b d^2) \left( 1 - \frac{\rho f_y}{1.7 f'_c} \right) = R_u b d^2 \end{aligned}$$

#### Section 4.4: Design of Rectangular Sections with Compression Steel

Given:  $M_u$ ,  $b$ ,  $d$ ,  $d'$ ,  $f'_c$ ,  $f_y$ , and  $\phi = 0.9$ .

Required:  $A_s$  and  $A'_s$ .

##### 1. General

- a. Calculate  $\rho_{\max}$  and  $\rho_{\min}$  as singly reinforced from equations (or from tables).
- b. Calculate  $R_{n,\max} = \rho_{\max} f_y \left[ 1 - \left( \frac{\rho_{\max} f_y}{1.7 f'_c} \right) \right]$  (or use tables).
- c. Calculate the maximum capacity of the section as singly reinforced:

$$\phi M_n = \phi R_{n,\max} b d^2$$

- d. If  $M_u > \phi M_n$ , then compression steel is needed. If  $M_u < \phi M_n$ , it is a singly reinforced section.
2. If  $M_u > \phi M_n$  and compression steel is needed:
    - a. Let  $M_{u1} = \phi R_{n,\max} b d^2$ .
    - b. Calculate  $A_{s1} = \rho_{\max} b d$  (basic section).
    - c. Calculate  $M_{u2} = M_u - M_{u1}$  (steel section).
  3. Calculate  $A_{s2}$  and  $A'_s$  as the steel section:
    - a.  $M_{u2} = \phi A_{s2} f_y (d - d')$ .
    - b. Calculate total tension steel:  $A_s = A_{s1} + A_{s2}$ .
  4. Calculate  $A'_s$  (compression steel area):
    - a. Calculate  $a = A_{s1} f_y / 0.85 f'_c b$  and  $c = a / \beta_1$ .
    - b. Calculate  $f'_s = 87[(c - d')/c] \leq f_y$ .  
If  $f'_s \geq f_y$ , then  $f'_s = f_y$  and  $A'_s = A_{s2}$ .  
If  $f'_s < f_y$ , then  $A'_s = A_{s2} \left( \frac{f_y}{f'_s} \right)$ .
    - c. Check that total steel area ( $A_s$ )  $\geq \max A_s$ , or check  $\epsilon_t \geq 0.005$ :

$$A_s \leq \left[ \rho_{\max} (b d) + A'_s \left( \frac{f'_s}{f_y} \right) \right]$$

#### Section 4.5: Design of T-Sections

Given:  $M_u$ ,  $f'_c$ ,  $f_y$ ,  $b$ ,  $t$ , and  $b_w$ .

Required:  $A_s$  and  $d$  (if not given).

There are two cases:

**Case 1** When  $d$  and  $A_s$  (or  $\rho$ ) are *not* given:

1. Let  $a \leq t$  (as singly reinforced rectangular section). If  $a = t$  is assumed, then

$$M_u = (\text{total flange}) = \phi(0.85f'_c)bt \left( d - \frac{t}{2} \right) = \phi A_s f_y \left( d - \frac{t}{2} \right)$$

Solve for  $d$  and then for  $A_s$ :

$$d = \frac{M_u}{\phi(0.85f'_c)bt} + \frac{t}{2} A_s = \frac{M_u}{\phi f_y (d - t/2)}$$

2. If  $a$  is assumed to be less than  $t$ , then

$$d = \frac{M_u}{\phi(0.85f'_c)ba} + \frac{a}{2} \quad \text{and} \quad A_s = \frac{M_u}{\phi f_y (d - a/2)}$$

**Case 2** When  $d$  is given and  $A_s$  is required (one unknown):

1. Check if ' $a$ ' is greater or less than  $t$  by considering the moment capacity of the flange ( $bt$ ).

$$(\text{flange})\phi M_n = \phi(0.85f'_c)bt \left( d - \frac{t}{2} \right)$$

If  $\phi M_n > M_u$  (external), then  $a < t$  (rectangular section).

If  $\phi M_n < M_u$  (external), then  $a > t$  (T-section).

2. If  $a < t$ , calculate  $R_n = M_u / \phi b d^2$  and then calculate  $\rho$  (or determine  $\rho$  from tables or Eq. 4.2):

$$\rho = \frac{0.85f'_c}{f_y} \left( 1 - \sqrt{1 - \frac{2R_n}{0.85f'_c}} \right)$$

Then calculate  $A_s = \rho b d$ .

3. If  $a > t$ :

- a. Calculate  $C_f$  and  $A_{sf}$ :

$$A_{sf} = 0.85f'_c t \frac{b - b_w}{f_y} = \frac{C_f}{f_y} (\text{flange})$$

Then calculate  $M_{uf} (\text{flange}) = \phi C_f (d - t/2)$ .

- b. Calculate  $M_{uw} (\text{web}) = M_u - M_{uf}$ . Calculate  $R_n$ ; (web)  $= M_{uw} / (\phi b_w d_2)$ ; then find  $\rho_w$  (use the equation or tables). Calculate  $A_{sw} (\text{web}) = \rho_w b_w d$ .

- c. Total  $A_s = A_{sf} (\text{flange}) + A_{sw} (\text{web})$ . Total  $A_s$  must be less than or equal to  $A_{s, \max}$  and greater than or equal to  $A_{s, \min}$ .

- d.

$$\rho_w = \left( \frac{0.8f'_c}{f_y} \right) \left( 1 - \sqrt{1 - \frac{2R_n}{0.85f'_c}} \right)$$

- e. Check that  $\rho_w = A_s / b_w d \geq \rho_{\min}$  ( $\rho_w$  = steel ratio in web) or  $A_s > A_{s, \min}$ , where  $A_{s, \min} = \rho_{\min} (b_w d)$ . Check that  $A_s \leq \max A_s$ , or check  $\epsilon_t = (d_t - c) / c \geq 0.005$ .

### PROBLEMS

- 4.1** Based on the information given in the accompanying table and for each assigned problem, design a singly reinforced concrete section to resist the factored moment shown in boldface. Use  $f'_c = 4$  ksi and  $f_y = 60$  ksi and draw a detailed, neat section.

No.	$M_u$ (K·ft)	$b$ (in.)	$d$ (in.)	$\rho\%$
a	272.7	12	21.5	—
b	969.2	18	32.0	—
c	816.0	16	—	1.70
d	657.0	16	—	1.50
e	559.4	14	—	1.75
f	254.5	10	21.5	—
g	451.4	14	—	1.80
h	832.0	18	28.0	—
i	345.0	15	—	1.77
j	510.0	0.5d	—	$\rho_{\max}$
k	720.0	—	2.5b	1.80
l	605.0	—	1.5b	1.80

For problems in SI units, 1 in. = 25.4 mm, 1 ksi = 6.9 MPa (N/mm<sup>2</sup>),  
and 1  $M_u$  (K·ft) = 1.356 kN·m.

- 4.2** Based on the information given in the following table and for each assigned problem, design a rectangular section with compression reinforcement to resist the factored moment shown. Use  $f'_c = 4$  ksi,  $f_y = 60$  ksi, and  $d' = 2.5$  in. Draw detailed, neat sections.

No.	$M_u$ (K·ft)	$b$ (in.)	$d$ (in.)
a	554	14	20.5
b	790	16	24.5
c	448	12	18.5
d	520	12	20.5
e	765	16	20.5
f	855	18	22.0
g	555	16	18.5
h	300	12	16.5
i	400	16	16.5
j	280	12	16.5
k	290	14	14.5
l	400	14	17.5

For problems in SI units, 1 in. = 25.4 mm, 1 ksi = 6.9 MPa (N/mm<sup>2</sup>),  
and 1  $M_u$  (K·ft) = 1.356 kN·m.

- 4.3** Based on the information given in the following table and for each assigned problem, calculate the tension steel and bars required to resist the factored moment shown. Use  $f'_c = 3$  ksi and  $f_y = 60$  ksi. Draw detailed, neat sections.

No.	$M_u$ (K·ft)	$b$ (in.)	$b_w$ (in.)	$t$ (in.)	$d$ (in.)	Notes
a	394	48	14	3	18.5	
b	800	60	16	4	19.5	
c	250	44	15	3	15.0	
d	327	50	14	3	13.0	
e	577	54	16	4	18.5	
f	559	48	14	4	17.5	
g	388	44	12	3	16.0	
h	380	46	14	3	15.0	
i	537	60	16	3	16.5	
j	515	54	16	3	17.5	
k	361	44	15	3	15.0	
l	405	50	14	3	15.5	
m	378	44	16	3	—	Let $a = t$
n	440	36	16	4	—	Let $a = t$
o	567	48	12	3	—	Let $A_s = 6.0 \text{ in.}^2$
p	507	46	14	3	—	Let $A_s = 7.0 \text{ in.}^2$

For problems in SI units, 1 in. = 25.4 mm, 1 ksi = 6.9 MPa (N/mm<sup>2</sup>), and 1  $M_u$  (K·ft) = 1.356 kN·m.

- 4.4** Design a singly reinforced rectangular section to resist a factored moment of 232 K · ft (320 kN·m) if  $f'_c = 4$  ksi (28 MPa),  $f_y = 60$  ksi (420 MPa), and  $b = 10$  in. (250 mm) using (a)  $\rho_{\max}$ , (b)  $\rho = 0.016$ , and (c)  $\rho = 0.012$ .
- 4.5** Design a singly reinforced section to resist a factored moment of 186 K · ft (252 kN · m) if  $b = 12$  in. (275 mm),  $d = 20$  in. (500 mm),  $f'_c = 3$  ksi (20 MPa), and  $f_y = 40$  ksi (300 MPa).
- 4.6** Determine the reinforcement required for the section given in Problem 4.5 when  $f'_c = 4$  ksi (30 MPa) and  $f_y = 60$  ksi (400 MPa).
- 4.7** A simply supported beam has a 20-ft (6-m) span and carries a uniform dead load (DL) of 800 lb/ft (12 kN/m) and a concentrated live load (LL) at midspan of 9 kips (40 kN) (Fig. 4.14). Design the beam if  $b = 12$  in. (300 mm),  $f'_c = 4$  ksi (30 MPa), and  $f_y = 60$  ksi (400 MPa). (Beam self-weight is not included in the dead load.)
- 4.8** A beam with a span of 24 ft (7.2 m) between supports has an overhanging extended part of 8 ft (2.4 m) on one side only. The beam carries a uniform dead load of 2.3 K/ft (30 kN/m) (including its own weight) and a uniform live load of 1.3 K/ft (18 kN/m) (Fig. 4.15). Design the smallest singly reinforced rectangular section to be used for the entire beam. Select steel for positive and negative moments. Use  $f'_c = 4$  ksi (30 MPa),  $f_y = 60$  ksi (400 MPa), and  $b = 12$  in. (300 mm). (Determine the maximum positive and maximum negative moments by placing the live load once on the span and once on the overhanging part.)

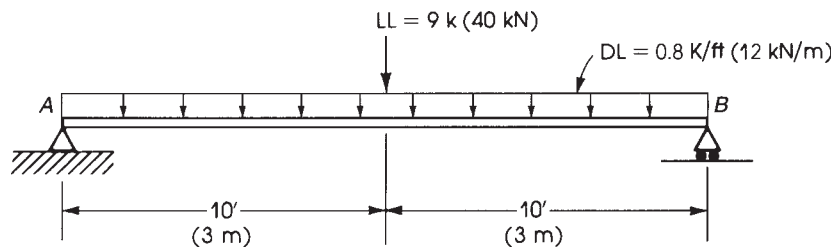


Figure 4.14 Problem 4.7.

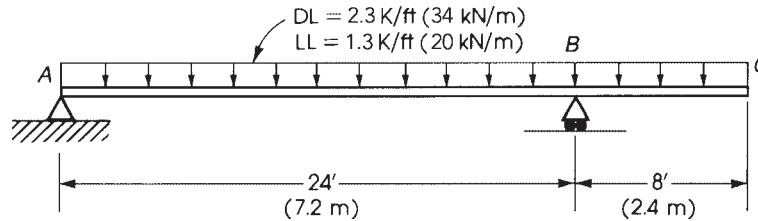


Figure 4.15 Problem 4.8.

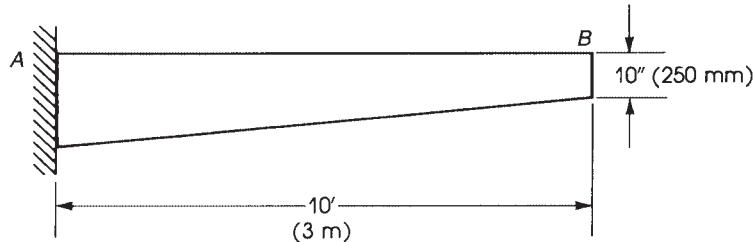


Figure 4.16 Problem 4.10.

- 4.9** Design a 15-ft (4.5-m) cantilever beam of uniform depth to carry a uniform dead load of 0.88 K/ft (12 kN/m) and a live load of 1.1 K/ft (15 kN/m). Assume a beam width  $b = 14$  in. (350 mm),  $f'_c = 4$  ksi (30 MPa), and  $f_y = 60$  ksi (400 MPa).
- 4.10** A 10-ft (3-m) cantilever beam carries a uniform dead load of 1.50 K/ft (20 kN/m) (including its own weight) and a live load of 0.77 K/ft (10 kN/m) (Fig. 4.16). Design the beam using a variable depth. Draw all details of the beam and reinforcement. Given:  $f'_c = 3$  ksi (20 MPa),  $f_y = 40$  ksi (300 MPa), and  $b = 12$  in. (300 mm). Assume  $h$  at the free end is 10 in. (250 mm).
- 4.11** Determine the necessary reinforcement for a concrete beam to resist an external factored moment of 290 K·ft (400 kN·m) if  $b = 12$  in. (300 mm),  $d = 19$  in. (475 mm),  $d' = 2.5$  in. (65 mm),  $f'_c = 3$  ksi (20 MPa), and  $f_y = 60$  ksi (400 MPa).
- 4.12** Design a reinforced concrete section that can carry a factored moment of 260 K·ft (360 kN·m) as:
- Singly reinforced,  $b = 10$  in. (250 mm)
  - Doubly reinforced, 25% of the moment to be resisted by compression steel,  $b = 10$  in. (250 mm)
  - T-section, which has a flange thickness of 3 in. (75 mm), flange width of 20 in. (500 mm), and web width of 10 in. (250 mm)

Then  $f'_c = 3$  ksi (20 MPa) and  $f_y = 60$  ksi (400 MPa) for all problems.

Determine the quantities of concrete and steel designed per foot length (meter length) of beams. Also, determine the cost of each design if the price of the concrete equals  $\$50/\text{yd}^3$  ( $67/\text{m}^3$ ) and that of steel is  $\$0.30/\text{lb}$  ( $\$0.66/\text{kg}$ ). Tabulate and compare results.

- 4.13** Determine the necessary reinforcement for a T-section that has a flange width  $b = 40$  in. (1000 mm), flange thickness  $t = 4$  in. (100 mm), and web width  $b_w = 10$  in. (250 mm) to carry a factored moment of 545 K·ft (750 kN·m). Given:  $f'_c = 3$  ksi (20 MPa) and  $f_y = 60$  ksi (400 MPa).
- 4.14** The two-span continuous beam shown in Fig. 4.17 is subjected to a uniform dead load of 2.6 K/ft (including its own weight) and a uniform live load of 3 K/ft. The reactions due to two different loadings are also shown. Calculate the maximum negative factored moment at the intermediate support  $B$  and the maximum positive factored moment within the span  $AB$  (at  $0.42L$  from support  $A$ ), design the critical section at  $B$  and  $D$ , and draw the reinforcement details for the entire beam  $ABC$ .

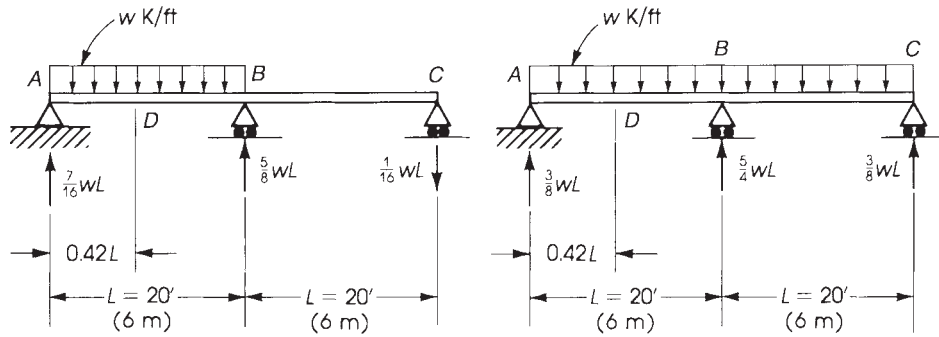


Figure 4.17 Problem 4.14.

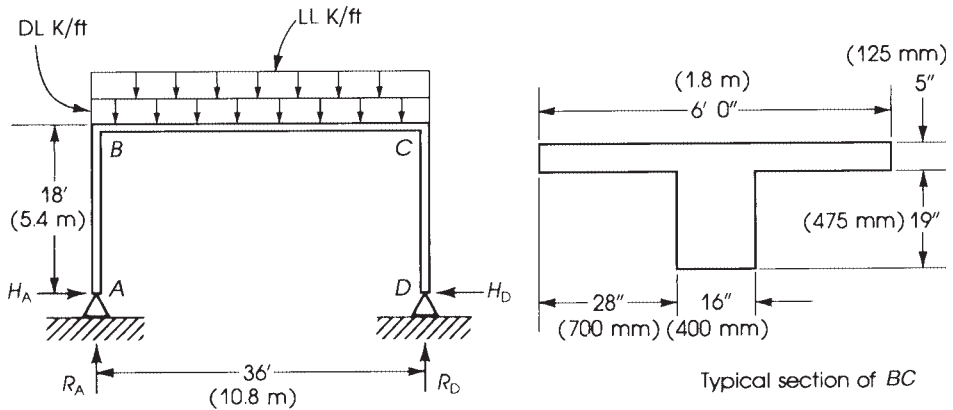


Figure 4.18 Problem 4.15.

Given:  $L = 20$  ft,  $b = 12$  in., and  $h = 24$  in. Use  $d = 18$  in. for one row of bars and  $d = 17$  in. for two rows. Assume  $f'_c = 4$  ksi and  $f_y = 60$  ksi.

**4.15** The two-hinged frame shown in Fig. 4.18 carries a uniform dead load of 3.93 K/ft and a uniform live load of 2.4 K/ft on BC. The reactions at A and D can be evaluated as follows:  $H_A = H_D = wL/9$  and  $R_A = R_D = wL/2$ , where  $w$  is the uniform load on BC. A typical cross section of the beam BC is also shown. It is required to:

- Draw the bending moment diagram for the frame ABCD.
- Design the beam BC for the applied factored moments (positive and negative).
- Draw the reinforcement details of BC.

Given:  $f'_c = 4$  ksi and  $f_y = 60$  ksi.

# CHAPTER 5

## SHEAR AND DIAGONAL TENSION



Office building, Chicago, Illinois.

### 5.1 INTRODUCTION

When a simple beam is loaded, as shown in Fig. 5.1, bending moments and shear forces develop along the beam. To carry the loads safely, the beam must be designed for both types of forces. Flexural design is considered first to establish the dimensions of the beam section and the main reinforcement needed, as explained in the previous chapters.

The beam is then designed for shear. If shear reinforcement is not provided, *shear failure* may occur. Shear failure is characterized by small deflections and lack of ductility, giving little or no warning before failure. On the other hand, flexural failure is characterized by a gradual increase in deflection and cracking, thus giving warning before total failure. This is due to the ACI Code limitation on flexural reinforcement. The design for shear must ensure that shear failure does not occur before flexural failure.

### 5.2 SHEAR STRESSES IN CONCRETE BEAMS

The general formula for the shear stress in a homogeneous beam is

$$v = \frac{VQ}{Ib} \quad (5.1)$$

where

$V$  = total shear at section considered

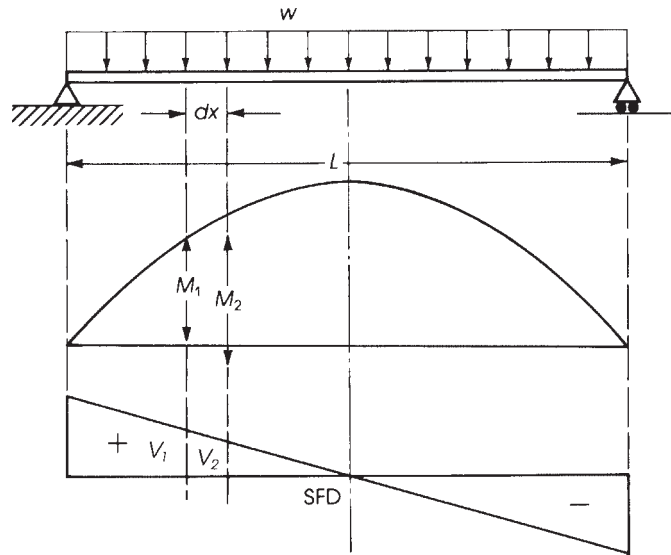
$Q$  = statical moment about neutral axis of that portion of cross section lying between line through point in question parallel to neutral axis and nearest face, upper or lower, of beam

$I$  = moment of inertia of cross section about neutral axis

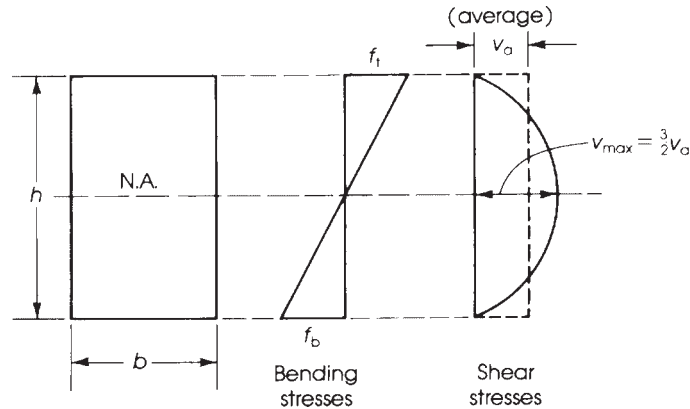
$b$  = width of beam at given point

The distribution of bending and shear stresses according to elastic theory for a homogeneous rectangular beam is as shown in Fig. 5.2. The bending stresses are calculated from the flexural





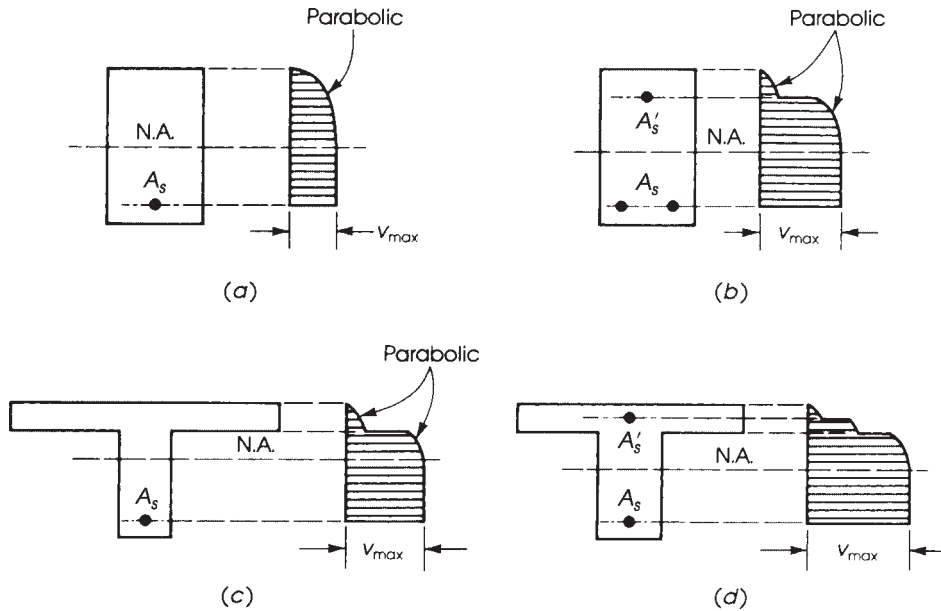
**Figure 5.1** Bending moment and shearing force diagrams for a simple beam.



**Figure 5.2** Bending and shear stresses in a homogeneous beam according to elastic theory.

formula  $f = Mc/I$ , whereas the shear stress at any point is calculated by the shear formula of Eq. 5.1. The maximum shear stress is at the neutral axis and is equal to  $1.5v_a$  (average shear), where  $v_a = V/bh$ . The shear stress curve is parabolic.

For a singly reinforced concrete beam, the distribution of shear stress above the neutral axis is a parabolic curve. Below the neutral axis, the maximum shear stress is maintained down to the level of the tension steel, because there is no change in the tensile force down to this point and the concrete in tension is neglected. The shear stress below the tension steel is zero (Fig. 5.3). For doubly reinforced and T-sections, the distribution of shear stresses is as shown in Fig. 5.3.



**Figure 5.3** Distribution of shear stresses in reinforced concrete beams: (a) singly reinforced, (b) doubly reinforced, (c) T-section, and (d) T-section with compression steel.

It can be observed that almost all the shear force is resisted by the web, whereas the flange resists a very small percentage; in most practical problems, the shear capacity of the flange is neglected.

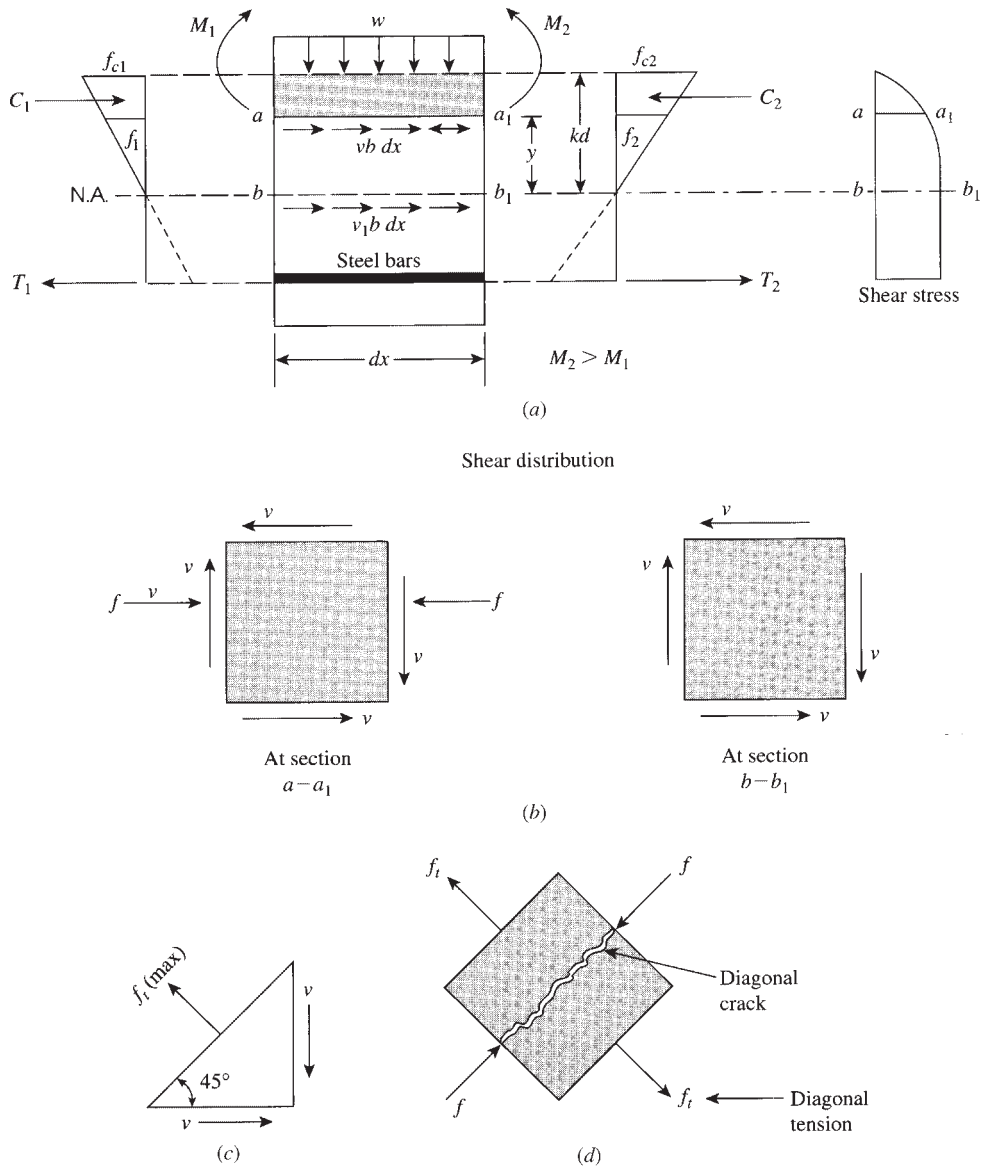
Referring to Fig. 5.1 and taking any portion of the beam  $dx$ , the bending moments at both ends of the element,  $M_1$  and  $M_2$ , are not equal. Because  $M_2 > M_1$  and to maintain the equilibrium of the beam portion  $dx$ , the compression force  $C_2$  must be greater than  $C_1$  (Fig. 5.4). Consequently, a shear stress  $v$  develops along any horizontal section  $a-a_1$  or  $b-b_1$  (Fig. 5.4a). The normal and shear stresses on a small element at levels  $a-a_1$  and  $b-b_1$  are shown in Fig. 5.4b. Notice that the normal stress at the level of the neutral axis  $b-b_1$  is zero, whereas the shear stress is at maximum. The horizontal shear stress is equal to the vertical shear stress, as shown in Fig. 5.4b. When the normal stress  $f$  is zero or low, a case of pure shear may occur. In this case, the maximum tensile stress  $f_t$  acts at  $45^\circ$  (Fig. 5.4c).

The tensile stresses are equivalent to the principal stresses, as shown in Fig. 5.4d. Such principal stresses are traditionally called *diagonal tension stresses*. When the diagonal tension stresses reach the tensile strength of concrete, a diagonal crack develops. This brief analysis explains the concept of diagonal tension and diagonal cracking. The actual behavior is more complex, and it is affected by other factors, as explained later. For the combined action of shear and normal stresses at any point in a beam, the maximum and minimum diagonal tension (principal stresses)  $f_p$  are given by the equation

$$f_p = \frac{1}{2}f \pm \sqrt{\left(\frac{1}{2}f\right)^2 + v^2} \quad (5.2)$$

where

$f$  = intensity of normal stress due to bending  
 $v$  = shear stress



**Figure 5.4** (a) Forces and stresses along depth of section, (b) normal and shear stresses, (c) pure shear, and (d) diagonal tension.

The shear failure in a concrete beam is most likely to occur where shear forces are at maximum, generally near the supports of the member. The first evidence of impending failure is the formation of diagonal cracks.

### 5.3 BEHAVIOR OF BEAMS WITHOUT SHEAR REINFORCEMENT

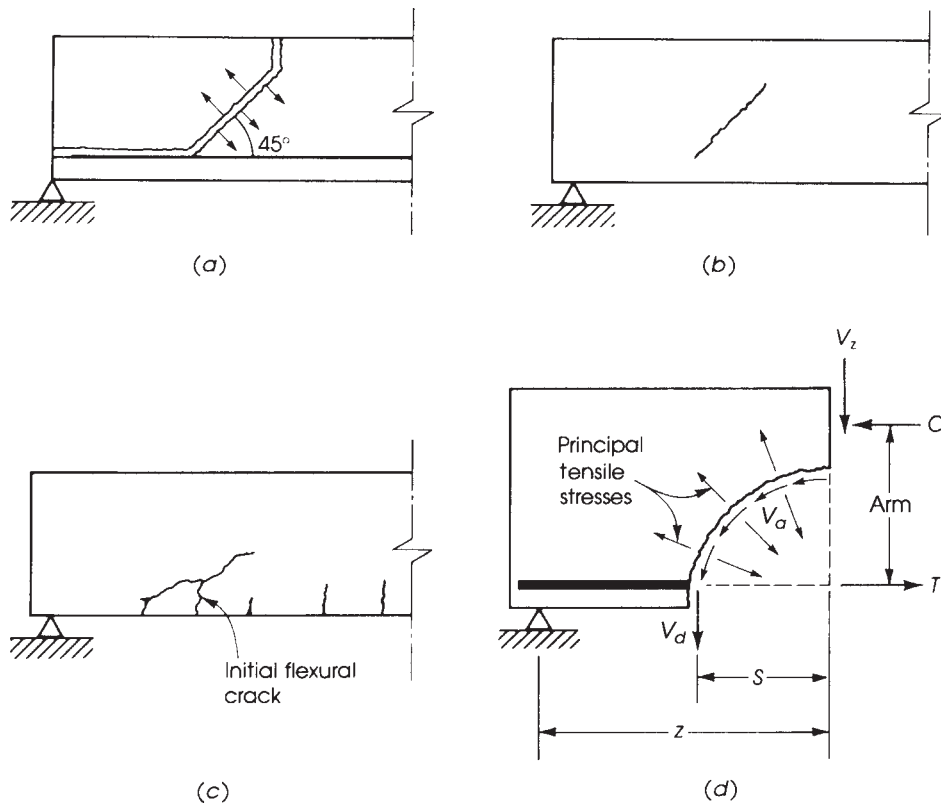
Concrete is weak in tension, and the beam will collapse if proper reinforcement is not provided. The tensile stresses develop in beams due to axial tension, bending, shear, torsion, or a combination

of these forces. The location of cracks in the concrete beam depends on the direction of principal stresses. For the combined action of normal stresses and shear stresses, maximum diagonal tension may occur at about a distance  $d$  from the face of the support.

The behavior of reinforced concrete beams with and without shear reinforcement tested under increasing load was discussed in Section 3.3. In the tested beams, vertical flexural cracks developed at the section of maximum bending moment when the tensile stresses in concrete exceeded the modulus of rupture of concrete, or  $f_r = 7.5\lambda\sqrt{f'_c}$ . Inclined cracks in the web developed at a later stage at a location very close to the support.

An inclined crack occurring in a beam that was previously uncracked is generally referred to as a *web-shear crack*. If the inclined crack starts at the top of an existing flexural crack and propagates into the beam, the crack is referred to as *flexural-shear crack* (Fig. 5.5). Web-shear cracks occur in beams with thin webs in regions with high shear and low moment. They are relatively uncommon cracks and may occur near the inflection points of continuous beams or adjacent to the supports of simple beams.

Flexural-shear cracks are the most common type found in reinforced concrete beams. A flexural crack extends vertically into the beam; then the inclined crack forms, starting from the top of the beam when shear stresses develop in that region. In regions of high shear stresses, beams must be reinforced by stirrups or by bent bars to produce ductile beams that do not rupture at a failure.



**Figure 5.5** Shear failure: (a) general form, (b) web-shear crack, (c) flexural-shear crack, (d) analysis of forces involved in shear ( $V_a$  = interface shear,  $V_z$  = shear resistance,  $V_d$  = dowel force).

To avoid a shear failure before a bending failure, a greater factor of safety must be provided against a shear failure. The ACI Code specifies a capacity reduction factor,  $\phi$ , of 0.75 for shear.

Shear resistance in reinforced concrete members is developed by a combination of the following mechanisms [2] (Fig. 5.5):

- Shear resistance of the uncracked concrete,  $V_z$  [3].
- Interface shear transfer,  $V_a$ , due to aggregate interlock tangentially along the rough surfaces of the crack [3].
- Arch action [4].
- Dowel action,  $V_d$ , due to the resistance of the longitudinal bars to the transverse shearing force [5].

In addition to these forces, shear reinforcement increases the shear resistance  $V_s$ , which depends on the diameter and spacing of stirrups used in the concrete member. If shear reinforcement is not provided in a rectangular beam, the proportions of the shear resisted by the various mechanisms are 20 to 40% by  $V_z$ , 35 to 50% by  $V_a$ , and 15 to 25% by  $V_d$  [6].

#### 5.4 MOMENT EFFECT ON SHEAR STRENGTH

In simply supported beams under uniformly distributed load, the midspan section is subjected to a large bending moment and zero or small shear, whereas sections near the ends are subjected to large shear and small bending moments (Fig. 5.1). The shear and moment values are both high near the intermediate supports of a continuous beam. At a location of large shear force and small bending moment, there will be little flexural cracking, and an average stress  $v$  is equal to  $V/bd$ . The diagonal tensile stresses are inclined at about  $45^\circ$  (Fig. 5.4c). Diagonal cracks can be expected when the diagonal tensile stress in the vicinity of the neutral axis reaches or exceeds the tensile strength of concrete. In general, the factored shear strength varies between  $3.5\sqrt{f'_c}$  and  $5\sqrt{f'_c}$ . After completing a large number of beam tests on shear and diagonal tension [1], it was found that in regions with large shear and small moment, diagonal tension cracks were formed at an average shear force of

$$V_c = 3.5\sqrt{f'_c}b_wd \quad (5.3)$$

where  $b_w$  is the width of the web in a T-section or the width of a rectangular section and  $d$  is the effective depth of the beam.

In locations where shear forces and bending moments are high, flexural cracks are formed first. At a later stage, some cracks bend in a diagonal direction when the diagonal tension stress at the upper end of such cracks exceeds the tensile strength of concrete. Given the presence of large moments on a beam, for which adequate reinforcement is provided, the nominal shear force at which diagonal tension cracks develop is given by

$$V_c = 1.9\lambda\sqrt{f'_c}b_wd \quad (5.4)$$

This value is a little more than half the value in Eq. 5.3 when bending moment is very small. This means that large bending moments reduce the value of shear stress for which cracking occurs. The following equation has been suggested to predict the nominal shear stress at which a diagonal crack is expected [1]:

$$v_c = \frac{V}{b_wd} = \left(1.9\lambda\sqrt{f'_c} + 2500\rho\frac{Vd}{M}\right) \leq 3.5\lambda\sqrt{f'_c} \quad (5.5)$$

1. ACI Code, Section 22.5.5.1, adopted this equation for the nominal shear force to be resisted by concrete for members subjected to shear and flexure only by

$$V_c = \left[ 1.9\lambda\sqrt{f'_c} + 2500\rho_w\frac{V_u d}{M_u} \right] b_w d \leq 3.5\lambda\sqrt{f'_c} b_w d \quad (5.6)$$

where  $\rho_w = A_s/b_w$ ,  $d$  and  $b_w$  are the web width in a T-section or the width of a rectangular section, and  $V_u$  and  $M_u$  are the factored shearing force and bending moment occurring simultaneously on the considered section.

The value of  $V_u d/M_u$  must not exceed 1.0 in Eq. 5.6. If  $M_u$  is large in Eq. 5.6, the second term becomes small and  $v_c$  approaches  $1.9\lambda\sqrt{f'_c}$ . If  $M_u$  is small, the second term becomes large and the upper limit of  $3.5\lambda\sqrt{f'_c}$  controls. As an alternative to Eq. 5.6, the ACI Code, Section 22.5.5.1, permits evaluating the shear strength of concrete as follows:

$$V_c = \begin{cases} 2\lambda\sqrt{f'_c} b_w d & (\text{lb.in.}) \\ 0.17\lambda\sqrt{f'_c} b_w d & (\text{SI}) \end{cases} \quad (5.7)$$

2. For members subjected to axial compression force  $N_u$  (ACI Code, Section 22.5.6.1)  $V_c$  shall be calculated by:

$$V_c = \left( 1.9\lambda\sqrt{f'_c} + 2500\rho_w\frac{V_u d}{M_m} \right) b_w d$$

$$M_m = M_u - N_u \left( \frac{4h - d}{8} \right) \quad (5.8)$$

where

$$\rho_w = A_s/(b_w d)$$

$h$  = overall depth

and  $V_u d/M_u$  may be greater than 1.0 but  $V_c$  must not exceed

$$V_c = 3.5\lambda\sqrt{f'_c} b_w d \sqrt{1 + \frac{N_u}{500A_g}} \quad (5.9)$$

where  $A_g$  is the gross area in square inches.



Shear failure near a middle support.

Alternatively,  $V_c$  may be computed by

$$V_c = b_w d \left( 2 + 0.001 \frac{N_u}{A_g} \right) \lambda \sqrt{f'_c} \quad (5.10)$$

3. In the case of members subjected to axial tensile force  $N_u$  (ACI Code, Section 22.5.7.1),  $V_c$  shall be calculated by:

$$V_c = b_w d \left( 2 + 0.004 \frac{N_u}{A_g} \right) \lambda \sqrt{f'_c} \quad (5.11)$$

where  $N_u$  is to be taken as negative for tension and  $N_u/A_g$  is in pounds per square inch. If  $V_c$  is negative,  $V_c$  should be taken equal to zero.

## 5.5 BEAMS WITH SHEAR REINFORCEMENT

Different types of shear reinforcement may be used:

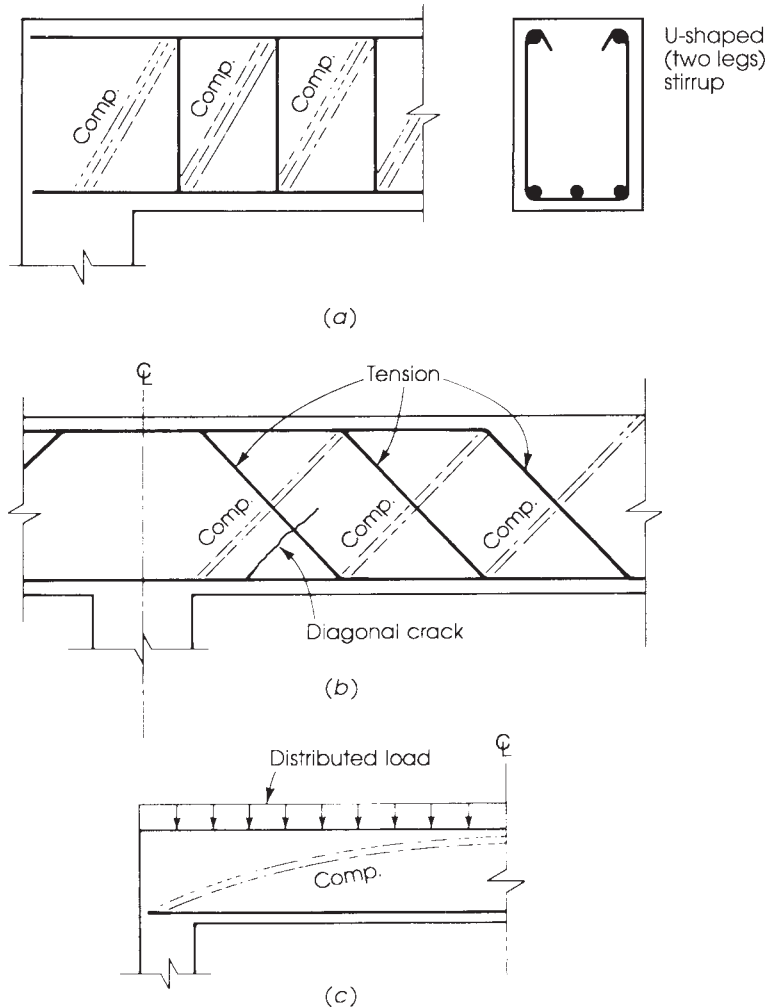
1. Stirrups, which can be placed either perpendicular to the longitudinal reinforcement or inclined, usually making a  $45^\circ$  angle and welded to the main longitudinal reinforcement. Vertical stirrups, using no. 3 or no. 4 U-shaped bars, are the most commonly used shear reinforcement in beams (Fig. 5.6a).
2. Bent bars, which are part of the longitudinal reinforcement, bent up (where they are no longer needed) at an angle of  $30^\circ$  to  $60^\circ$ , usually at  $45^\circ$ .
3. Combinations of stirrups and bent bars.
4. Welded wire fabric with wires perpendicular to the axis of the member.
5. Spirals, circular ties, or hoops in circular sections, as columns.

The shear strength of a reinforced concrete beam is increased by the use of shear reinforcement. Prior to the formation of diagonal tension cracks, shear reinforcement contributes very little to the shear resistance. After diagonal cracks have developed, shear reinforcement augments the shear resistance of a beam, and a redistribution of internal forces occurs at the cracked section. When the amount of shear reinforcement provided is small, failure due to yielding of web steel may be expected, but if the amount of shear reinforcement is too high, a shear-compression failure may be expected, which should be avoided.

Concrete, stirrups, and bent bars act together to resist transverse shear. The concrete, by virtue of its high compressive strength, acts as the diagonal compression member of a lattice girder system, where the stirrups act as vertical tension members. The diagonal compression force is such that its vertical component is equal to the tension force in the stirrup. Bent-up reinforcement acts also as tension members in a truss, as shown in Fig. 5.6.

In general, the contribution of shear reinforcement to the shear strength of a reinforced concrete beam can be described as follows [2]:

1. It resists part of the shear,  $V_s$ .
2. It increases the magnitude of the interface shear,  $V_a$  (Fig. 5.5), by resisting the growth of the inclined crack.
3. It increases the dowel force,  $V_d$  (Fig. 5.5), in the longitudinal bars.
4. The confining action of the stirrups on the compression concrete may increase its strength.



**Figure 5.6** Truss action of web reinforcement with (a) stirrups, (b) bent bars, and (c) tension steel.

5. The confining action of stirrups on the concrete increases the rotation capacity of plastic hinges that develop in indeterminate structures at maximum load and increases the length over which yielding takes place [7].

The total nominal shear strength of beams with shear reinforcement  $V_n$  is due partly to the shear strength attributed to the concrete,  $V_c$ , and partly to the shear strength contributed by the shear reinforcement,  $V_s$ :

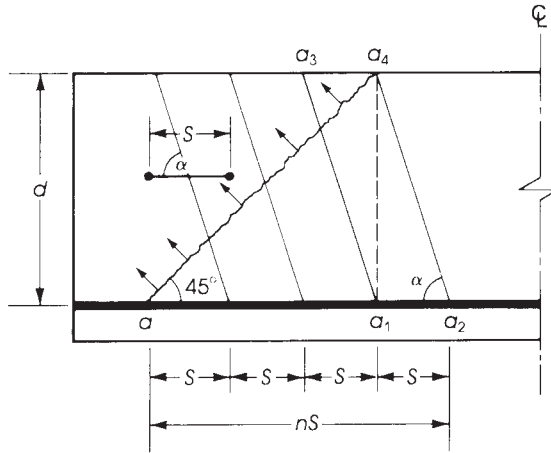
$$V_n = V_c + V_s \tag{5.12}$$

The shear force  $V_u$  produced by factored loads must be less than or equal to the total nominal shear strength  $V_n$ , or

$$V_u \leq \phi V_n = \phi(V_c + V_s) \tag{5.13}$$

where  $V_u = 1.2V_D + 1.6V_L$  and  $\phi = 0.75$ .





**Figure 5.7** Factors in inclined shear reinforcement.

An expression for  $V_s$  may be developed from the truss analogy (Fig. 5.7). For a  $45^\circ$  crack and a series of inclined stirrups or bent bars, the vertical shear force  $V_s$  resisted by shear reinforcement is equal to the sum of the vertical components of the tensile forces developed in the inclined bars. Therefore,

$$V_s = nA_v f_{yt} \sin \alpha \quad (5.14)$$

where  $A_v$  is the area of shear reinforcement with a spacing  $s$  and  $f_{yt}$  is the yield strength of shear reinforcement;  $ns$  is defined as the distance  $aa_1a_2$ :

$$d = \begin{cases} a_1a_4 = aa_1 \tan 45^\circ & \text{(from triangle } aa_1a_4) \\ a_1a_4 = a_1a_2 \tan \alpha & \text{(from triangle } a_1a_2a_4) \end{cases}$$

$$ns = aa_1 + a_1a_2$$

$$= d(\cot 45^\circ + \cot \alpha) = d(1 + \cot \alpha)$$

$$n = \frac{d}{S}(1 + \cot \alpha)$$

Substituting this value in Eq. 5.14 gives

$$V_s = \frac{A_v f_{yt} d}{S} \sin \alpha (1 + \cot \alpha) = \frac{A_v f_{yt} d}{S} (\sin \alpha + \cos \alpha) \quad (5.15)$$

For the case of vertical stirrups,  $\alpha = 90^\circ$  and

$$V_s = \frac{A_v f_{yt} d}{S} \quad \text{or} \quad S = \frac{A_v f_{yt} d}{V_s} \quad (5.16)$$

In the case of T-sections,  $b$  is replaced by the width of web  $b_w$  in all shear equations. When  $\alpha = 45^\circ$ , Eq. 5.15 becomes

$$V_s = 1.4 \left( \frac{A_v f_{yt} d}{S} \right) \quad \text{or} \quad S = \frac{1.4 A_v f_{yt} d}{V_s} \quad (5.17)$$

For a single bent bar or group of parallel bars in one position, the shearing force resisted by steel is

$$V_s = A_v f_{yt} \sin \alpha \quad \text{or} \quad A_v = \frac{V_s}{f_{yt} \sin \alpha} \quad (5.18)$$

For  $\alpha = 45^\circ$ ,

$$A_v = 1.4 \left( \frac{V_s}{f_{yt}} \right) \quad (5.19)$$

For circular sections, mainly in columns,  $V_s$  will be computed from Eq. 5.16 using  $d = 0.8 \times \text{diameter}$  and  $A_v = \text{two times the area of the bar in a circular tie, hoop, or spiral}$ .

## 5.6 ACI CODE SHEAR DESIGN REQUIREMENTS

### 5.6.1 Critical Section for Nominal Shear Strength Calculation

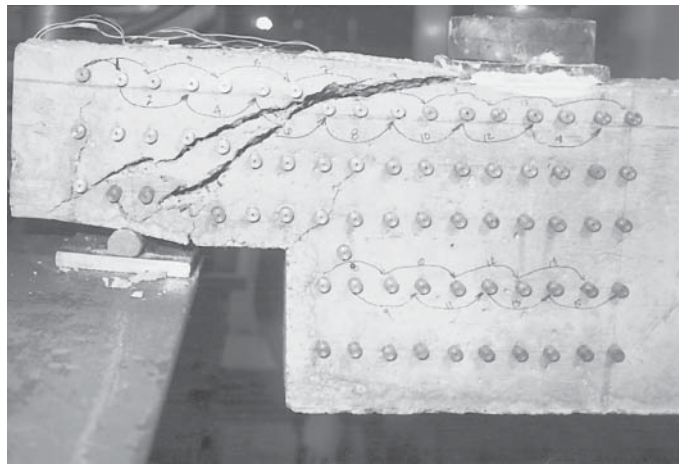
The ACI Code, Section 7.4.3.2, permits taking the critical section for nominal shear strength calculation at a distance  $d$  from the face of the support. This recommendation is based on the fact that the first inclined crack is likely to form within the shear span of the beam at some distance  $d$  away from the support. The distance  $d$  is also based on experimental work and appeared in the testing of the beams discussed in Chapter 3. This critical section is permitted on the condition that the support reaction introduces compression into the end region, loads are applied at or near the top of the member, and no concentrated load occurs between the face of the support and the location of the critical section.

The Code also specifies that shear reinforcement must be provided between the face of the support and the distance  $d$  using the same reinforcement adopted for the critical section.

### 5.6.2 Minimum Area of Shear Reinforcement

The presence of shear reinforcement in a concrete beam restrains the growth of inclined cracking. Moreover, ductility is increased, and a warning of failure is provided. If shear reinforcement is not provided, brittle failure will occur without warning. Accordingly, a minimum area of shear reinforcement is specified by the Code. The ACI Code, Section 9.6.3.3, requires all stirrups to have a minimum shear reinforcement area,  $A_v$ , equal to

$$A_v = 0.75 \sqrt{f'_c} \left( \frac{b_w s}{f_{yt}} \right) \geq \frac{50 b_w s}{f_{yt}} \quad (5.20)$$



Shear failure in dapped-end beam.

where  $b_w$  is the width of the web and  $s$  is the spacing of the stirrups. The minimum amount of shear reinforcement is required whenever  $V_u$  exceeds  $\phi V_c/2$ , except in:

1. Slabs and footings.
2. Concrete floor joist construction.
3. Beams where the total depth ( $h$ ) does not exceed 10 in., 2.5 times the flange thickness for T-shaped flanged sections, or one-half the web width, whichever is greatest.
4. The beam is integrated with slab,  $h$  not greater 24 in. and not greater than the larger of 2.5 times the thickness of the flange and 0.5 times the width of the web.

If  $0.75\sqrt{f'_c} = 50$ , then  $f'_c = 4444$  psi. This means that, when  $f'_c < 4500$  psi, the minimum  $A_v = 50 b_w s/f_{yt}$  controls, and when  $f'_c \geq 4500$  psi, the minimum  $A_v = 0.75\sqrt{f'_c} (b_w s/f_{yt})$  controls. This increase in the minimum area of shear reinforcement for  $f'_c \geq 4500$  psi is to prevent sudden shear failure when inclined cracking occurs.

It is common practice to increase the depth of a slab, footing, or shallow beam to increase its shear capacity. Stirrups may not be effective in shallow members, because their compression zones have relatively small depths and may not satisfy the anchorage requirements of stirrups. For beams that are not shallow, reinforcement is not required when  $V_u$  is less than  $\phi V_c/2$ .

The minimum shear reinforcement area can be achieved by using no. 3 stirrups placed at maximum spacing,  $S_{\max}$ . If  $f_y = 60$  ksi and U-shaped (two legs) no. 3 stirrups are used, then Eq. 5.20 becomes

$$S_{\max} = \frac{A_v f_{yt}}{(0.75\sqrt{f'_c})b_w} \leq \frac{A_v f_{yt}}{50b_w} \quad (5.21)$$

where

$$S_{\max} \text{ (in.)} = \begin{cases} \frac{0.22(60,000)}{50b_w} = \frac{264}{b_w} & \text{for } f'_c < 4500 \text{ psi} \\ \frac{262}{b_w} & \text{for } f'_c = 4500 \text{ psi} \\ \frac{249}{b_w} & \text{for } f'_c = 5000 \text{ psi} \\ \frac{227}{b_w} & \text{for } f'_c = 6000 \text{ psi} \end{cases} \quad (5.22)$$

If U-shaped no. 4 stirrups are used, then, for  $f'_c < 4500$  psi,

$$S_{\max} \text{ (in.)} = \frac{0.4(60,000)}{50b_w} = \frac{480}{b_w}$$

where

$$S_{\max} \text{ (in.)} = \begin{cases} \frac{476}{b_w} & \text{for } f'_c = 4500 \text{ psi} \\ \frac{453}{b_w} & \text{for } f'_c = 5000 \text{ psi} \\ \frac{413}{b_w} & \text{for } f'_c = 6000 \text{ psi} \end{cases} \quad (5.23)$$

Note that  $S_{\max}$  shall not exceed 24 in., or  $d/2$ .

**Table 5.1** Values of  $S_{\max} = A_v f_y / 50 b_w = 24$  in. When  $f_{yt} = 60$  ksi and  $f'_c < 4500$  psi

$b_w$ (in.)	10	11	12	13	14	15	16	18	20	22	24	$b_w$
$S_{\max}$ (in.) no. 3 stirrups	24	24	22	20.3	18.9	17.6	16.5	14.7	13.2	12	11	$264/b_w$
$S_{\max}$ (in.) no. 4 stirrups	24	24	24	24	24	24	24	24	24	21.8	20	$480/b_w$

Table 5.1 gives  $S_{\max}$  based on Eqs. 5.22 and Eqs. 5.23. Final spacings should be rounded to the lower inch. For example,  $S = 20.3$  in. becomes 20 in.

### 5.6.3 Maximum Shear Carried by Web Reinforcement $V_s$

To prevent a shear–compression failure, where the concrete may crush due to high shear and compressive stresses in the critical region on top of a diagonal crack, the ACI Code, Section 22.5.1.2, requires that  $V_s$  shall not exceed  $(8\sqrt{f'_c})b_w d$ . If  $V_s$  exceeds this value, the section should be increased. Based on this limitation,

$$\text{If } f'_c = 3 \text{ ksi, then } V_s \leq 0.438b_w d \text{ (kips) or } V_s/b_w d \leq 438 \text{ psi.}$$

$$\text{If } f'_c = 4 \text{ ksi, then } V_s \leq 0.506b_w d \text{ (kips) or } V_s/b_w d \leq 506 \text{ psi.}$$

$$\text{If } f'_c = 5 \text{ ksi, then } V_s \leq 0.565b_w d \text{ (kips) or } V_s/b_w d \leq 565 \text{ psi.}$$

### 5.6.4 Maximum Spacing of Stirrups

To ensure that a diagonal crack will always be intersected by at least one stirrup, the ACI Code, Section 9.7.6.2, requires that the spacing between stirrups shall not exceed  $d/2$ , or 24 in., provided that  $V_s \leq (4\sqrt{f'_c})b_w d$ . This is based on the assumption that a diagonal crack develops at  $45^\circ$  and extends a horizontal distance of about  $d$ . In regions of high shear, where  $V_s$  exceeds  $(4\sqrt{f'_c})b_w d$ , the maximum spacing between stirrups must not exceed  $d/4$ . This limitation is necessary to ensure that the diagonal crack will be intersected by at least three stirrups. When  $V_s$  exceeds the maximum value of  $(8\sqrt{f'_c})b_w d$ , this limitation of maximum stirrup spacing does not apply, and the dimensions of the concrete cross section should be increased.

A second limitation for the maximum spacing of stirrups may also be obtained from the condition of minimum area of shear reinforcement. A minimum  $A_v$  is obtained when the spacing  $s$  is maximum (Eq. 5.21).

A third limitation for maximum spacing is 24 in. when  $V_s \leq (4\sqrt{f'_c})b_w d$  and 12 in. when  $V_s$  is greater than  $(4\sqrt{f'_c})b_w d$  but less than or equal to  $(8\sqrt{f'_c})b_w d$ . The least value of all maximum spacings must be adopted. The ACI Code maximum spacing requirement ensures closely spaced stirrups that hold the longitudinal tension steel in place within the beam, thereby increasing their dowel capacity,  $V_d$  (Fig. 5.5).

### 5.6.5 Yield Strength of Shear Reinforcement

The ACI Code, Section 20.2.2.4, requires that the design yield strength of shear reinforcement shall not exceed 60 ksi (420 MPa). The reason behind this decision is to limit the crack width caused by the diagonal tension and to ensure that the sides of the crack remain in close contact to improve the interface shear transfer,  $V_a$  (Fig. 5.5). For welded deformed wire fabric, the design yield strength shall not exceed 80 ksi (560 MPa).

### 5.6.6 Anchorage of Stirrups

The ACI Code, Section 25.7.1.1, requires that shear reinforcement be carried as close as possible to the compression and tension extreme fibers, within the Code requirements for concrete cover, because near maximum load the flexural tension cracks penetrate deep into the beam. Also, for stirrups to achieve their full yield strength, they must be well anchored. Near maximum load, the stress in a stirrup reaches its yield stress at the point where a diagonal crack intercepts that stirrup. The ACI Code requirements for stirrup anchorage, Section 25.7, are as follows:

1. Each bend in the continuous portion of a simple U-stirrup or multiple U-stirrups shall enclose a longitudinal bar (ACI Code, Section 25.7.1.1). See Fig. 5.8a.
2. The code allows the use of a standard hook of  $90^\circ$ ,  $135^\circ$ , or  $180^\circ$  around longitudinal bars for no. 5 bars or D31 wire stirrups and no. 6, 7, and 8 bars with  $f_{yt} < 40$  ksi. If no. 6, 7, or 8 stirrups with  $f_{yt} > 40$  ksi are used, the code (Section 25.7.1.3) requires a standard hook plus an embedment length of  $0.014d_b f_{yt} / (\lambda \sqrt{f'_c})$  between midheight of the member and the outside of the hook. If the bars are bent at  $90^\circ$ , extensions shall not be less than  $12d_b$ . For no. 5 bars or smaller stirrups, the extension is  $6d_b$  (ACI Code, Section 25.3.2). See Fig. 5.8b.
3. If spliced double U-stirrups are used to form closed stirrups, the lap length shall not be less than  $1.3l_d$  (ACI Code, Section 25.7.1.7). See Fig. 5.8c.
4. Welded wire fabric is used for shear reinforcement in the precast industry. Anchorage details are given in the ACI Code, Section 25.7.1.4, and in its commentary.
5. Closed stirrups are required for beams subjected to torsion or stress reversals (ACI Code, Section 9.7.6.4).
6. Beams at the perimeter of the structure should contain closed stirrups to maintain the structural integrity of the member (ACI Code, Section 9.7.7.2).

### 5.6.7 Stirrups Adjacent to the Support

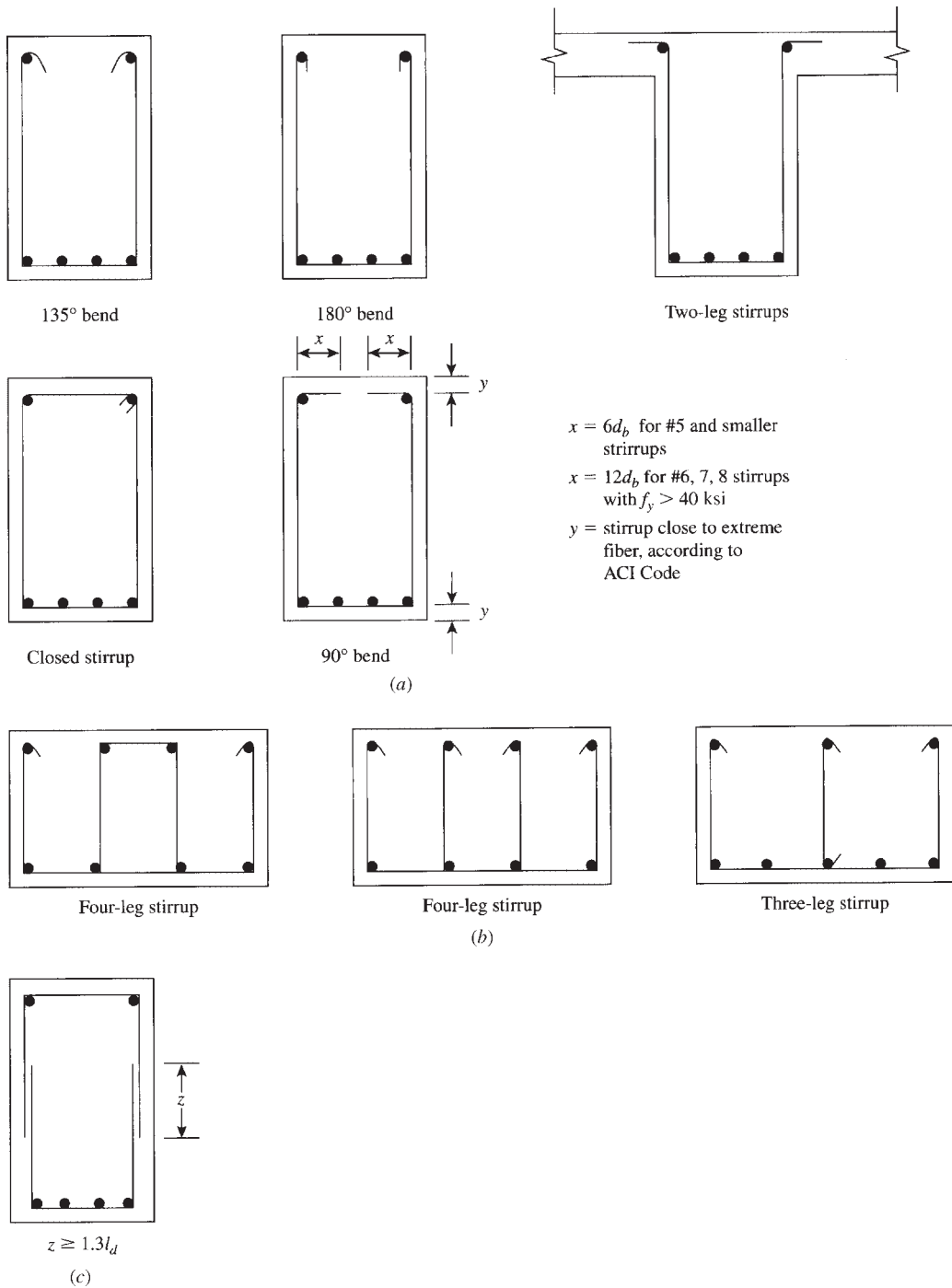
The ACI Code, Section 7.4.3.2, specifies that shear reinforcement provided between the face of the support and the critical section at a distance  $d$  from it may be designed for the same shear  $V_u$  at the critical section. It is common practice to place the first stirrup at a distance  $S/2$  from the face of the support, where  $s$  is the spacing calculated by Eq. 5.16 for  $V_u$  at the critical section.

### 5.6.8 Effective Length of Bent Bars

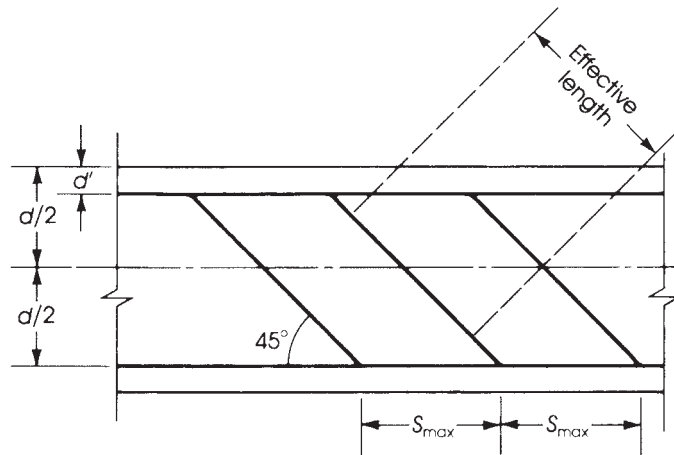
Only the center three-fourths of the inclined portion of any longitudinal bar shall be considered effective for shear reinforcement. This means that the maximum spacing of bent bars is  $0.75(d - d')$ . From Fig. 5.9, the effective length of the bent bar is  $0.75(d - d') / (\sin 45^\circ) = 0.75(1.414)(d - d') = 1.06(d - d')$ . The maximum spacing  $S$  is equal to the horizontal projection of the effective length of the bent bar. Thus  $S_{\max} = 1.06(d - d') \cos 45^\circ$ , or  $S_{\max} = 0.707[1.06(d - d')] = 0.75(d - d')$ .

## 5.7 DESIGN OF VERTICAL STIRRUPS

Stirrups are needed when  $V_u \geq \phi V_c$ . Minimum stirrups are used when  $V_u$  is greater than  $\frac{1}{2}\phi V_c$  but less than  $\phi V$ . This is achieved by using no. 3 stirrups placed at maximum spacing. When  $V_u$  is greater than  $\phi V$ , stirrups must be provided. The spacing of stirrups may be less than the maximum spacing and can be calculated using Eq. 5.16:  $S = A_v f_{yt} d / V_s$ .



**Figure 5.8** Stirrup types: (a) U-stirrups enclosing longitudinal bars, anchorage lengths, and closed stirrups; (b) multileg stirrups; and (c) spliced stirrups.



**Figure 5.9** Effective length and spacing of bent bars.

The stirrups that are commonly used in concrete sections are made of two-leg no. 3 or no. 4 U-stirrups with  $f_{yt} = 60$  ksi. If no. 3 stirrups are used, then Eq. 5.16 becomes

$$\frac{S}{d} = \frac{A_v f_y}{V_s} = \frac{0.22(60)}{V_s} = \frac{13.2}{V_s} \quad (5.24)$$

If no. 4 stirrups are used, then

$$\frac{S}{d} = \frac{A_v f_y}{V_s} = \frac{0.4(60)}{V_s} = \frac{24}{V_s} \quad (5.25)$$

The ratio of stirrups spacing relative to the effective depth of the beam,  $d$ , depends on  $V_s$ . The values of  $S/d$  for different values of  $V_s$  when  $f_y = 60$  ksi are given in Tables 5.2 and 5.3 for no. 3 and no. 4 U-stirrups, respectively. The same values are plotted in Figs. 5.10 and 5.11. The following observations can be made:

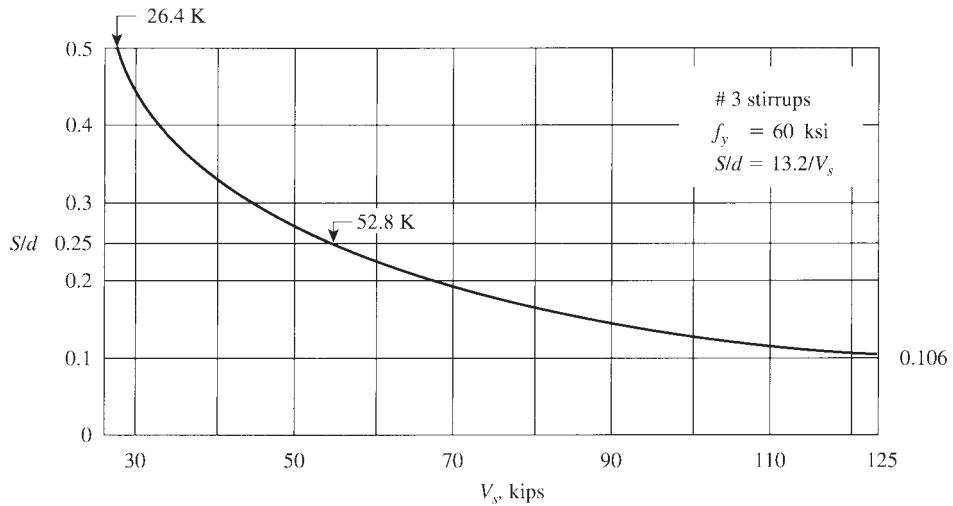
1. If no. 3 stirrups are used,  $S = d/2$  when  $V_s \leq 26.4$ . When  $V_s$  increases,  $S/d$  decreases in a nonlinear curve to reach 0.132 at  $V_s = 100$  K. If the minimum spacing is limited to 3 in., then

**Table 5.2**  $S/d$  Ratio for Different Values of  $V_s$  ( $f_{yt} = 60$  ksi,  $S/d = 13.2/V_s$ ), No. 3 Stirrups

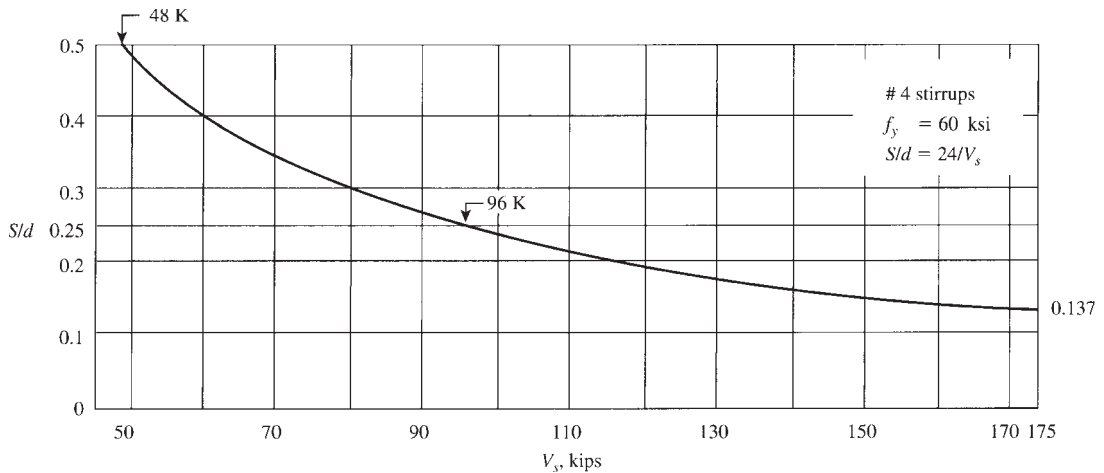
$V_s$ (K)	26.4	30	40	50	52.8	60	70	80	90	100	125
$S/d$	0.5	0.44	0.33	0.264	0.25	0.22	0.19	0.165	0.15	0.132	0.106

**Table 5.3**  $S/d$  Ratio for Different Values of  $V_s$  ( $f_{yt} = 60$  ksi,  $S/d = 24/V_s$ ), No. 4 Stirrups

$V_s$ (K)	48	50	60	70	80	90	96	100	110	120	150	175
$S/d$	0.50	0.48	0.40	0.34	0.3	0.27	0.25	0.24	0.22	0.20	0.16	0.137



**Figure 5.10**  $V_s$  versus  $S/d$  for no. 3 stirrups and  $f_{yt} = 60$  ksi.



**Figure 5.11**  $V_s$  versus  $S/d$  for no. 4 stirrups and  $f_{yt} = 60$  ksi.

$d$  must be equal to or greater than 22.7 in. to maintain that 3-in. spacing. When  $V_s$  is equal to or greater than 52.8 K, then  $S \leq d/4$ .

2. If no. 4 U-stirrups are used,  $S = d/2$  when  $V_s \leq 48$  k. When  $V_s$  increases,  $S/d$  decreases to reach 0.16 at  $V_s = 150$  K. If the minimum spacing is limited to 3 in., then  $d \geq 18.75$  in. to maintain the 3-in. spacing. When  $V_s$ , then  $S$ .
3. If grade 40 U-stirrups are used ( $f_{yt} = 40$  ksi), multiply the  $S/d$  values by  $\frac{2}{3}$  or, in general,  $f_{yt}/60$ .



## 5.8 DESIGN SUMMARY

The design procedure for shear using vertical stirrups according to the ACI Code can be summarized as follows:

1. Calculate the factored shearing force,  $V_u$ , from the applied forces acting on the structural member. The critical design shear value is at a section located at a distance  $d$  from the face of the support.
2. Calculate  $\phi V_c = \phi 2\lambda\sqrt{f'_c}b_wd$ , or

$$\phi V_c = \phi \left[ 1.9\lambda\sqrt{f'_c} + 2500\rho_w \frac{V_u d}{M_u} \right] b_w d \leq \phi 3.5\lambda\sqrt{f'_c}b_w d$$

Then calculate  $\frac{1}{2}\phi V_c$ .

3. **a.** If  $V_u < \frac{1}{2}\phi V_c$ , no shear reinforcement is needed.
- b.** If  $\frac{1}{2}\phi V_c < V_u \leq \phi V_c$ , minimum shear reinforcement is required. Use no. 3 U-stirrups spaced at maximum spacings, as explained in step 7.
- c.** If  $V_u > \phi V_c$ , shear reinforcement must be provided according to steps 4 through 8.
4. If  $V_u > \phi V_c$ , calculate the shear to be carried by shear reinforcement:

$$V_u = \phi V_c + \phi V_s \quad \text{or} \quad V_s = \frac{V_u - \phi V_c}{\phi}$$

5. Calculate  $V_{c1} = (4\sqrt{f'_c})b_wd$  and  $V_{c2} = (8\sqrt{f'_c})b_wd = 2V_{c1}$ . Compare the calculated  $V_s$  with the maximum permissible value of  $V_{c2} = (8\sqrt{f'_c})b_wd$ . If  $V_s < V_{c2}$  proceed in the design; if not, increase the dimensions of the section.
6. Calculate the stirrups spacing based on the calculated  $S_1 = A_v f_{yt} d / V_s$  or use Figs. 5.10 and 5.11 or Tables 5.2 and 5.3.
7. Determine the maximum spacing allowed by the ACI Code. The maximum spacing is the least of  $S_2$  and  $S_3$ :
  - a.**  $S_2 = d/2 \leq 24$  in. if  $V_s \leq V_{c1} = (4\sqrt{f'_c})b_wd$ .
  - b.**  $S_3 = A_v f_{yt} / 50b_w \geq A_v f_{yt} / (0.75\sqrt{f'_c}b_w)$ .
 Thus,  $S_{\max}$  is the smaller of  $S_2$  and  $S_3$ . Values of  $S_3$  are shown in Table 5.1.
8. If  $S_1$  calculated in step 6 is less than  $S_{\max}$  (the smaller of  $S_2$  and  $S_3$ ), then use  $S_1$  to the nearest smaller  $\frac{1}{2}$  in. If  $S_1 > S_{\max}$ , then use  $S_{\max}$  as the adopted  $S$ .
9. The ACI Code did not specify a minimum spacing. Under normal conditions, a practical minimum  $S$  may be assumed to be equal to 3 in. for  $d \leq 20$  in. and 4 in. for deeper beams. If  $S$  is considered small, either increase the stirrup bar number or use multiple-leg stirrups (Fig. 5.8).
10. For circular sections, the area used to compute  $V_c$  is the diameter times the effective depth  $d$ , where  $d = 0.8$  times the diameter, ACI Code, Section 22.5.2.2.

**Example 5.1**

A simply supported beam has a rectangular section with  $b = 12$  in.,  $d = 21.5$  in., and  $h = 24$  in. and is reinforced with four no. 8 bars. Check if the section is adequate for each of the following factored shear forces. If it is not adequate, design the necessary shear reinforcement in the form of U-stirrups. Use  $f'_c = 4$  ksi and  $f_{yt} = 60$  ksi. Assume normal-weight concrete.

(a)  $V_u = 12$  K, (b)  $V_u = 24$  K, (c)  $V_u = 54$  K, (d)  $V_u = 77$  K, (e)  $V_u = 128$  K

**Solution**

In general,  $b_w = b = 12$  in.,  $d = 21.5$  in., and

$$\phi V_c = \phi(2\lambda\sqrt{f'_c})bd = 0.75(2)(1)(\sqrt{4000})(12)(21.5) = 24.5 \text{ K}$$

$$\frac{1}{2}\phi V_c = 12.25 \text{ K}$$

$$V_{c1} = (4\sqrt{f'_c})bd = \frac{(4\sqrt{4000})(12)(21.5)}{1000} = 65.3 \text{ K}$$

$$V_{c2} = (8\sqrt{f'_c})bd = 130.6 \text{ K}$$

- a. Assume  $V_u = 12 \text{ K} < \frac{1}{2}\phi V_c = 12.25 \text{ K}$ , the section is adequate, and shear reinforcement is not required.
- b. Assume  $V_u = 24 \text{ K} > \frac{1}{2}\phi V_c$ , but it is less than  $\phi V_c = 24.5 \text{ K}$ . Therefore,  $V_s = 0$  and minimum shear reinforcement is required. Choose a no. 3 U-stirrup (two legs) at maximum spacing. Let  $A_v = 2(0.11) = 0.22 \text{ in}^2$ . Maximum spacing is the least of

$$S_2 = \frac{d}{2} = \frac{21.5}{2} = 10.75 \text{ in. say, } 10.5 \text{ in. (controls)}$$

$$S_3 = \frac{A_v f_{yt}}{50b_w} = \frac{0.22(60,000)}{50(12)} = 22 \text{ in. (or use Table 5.1)}$$

$$S_4 = 24 \text{ in.}$$

Use no.3 U-stirrups spaced at 10.5 in.

- c. Assume  $V_u = 54 \text{ K} > \phi V_c$ . Shear reinforcement is needed. Calculation may be organized in steps: Calculate  $V_s = (V_u - \phi V_c)/\phi = (54 - 24.5)/0.75 = 39.3 \text{ K}$ .

Check if  $V_s \leq V_{c1} = (4\sqrt{f'_c})b_w d = 65.3 \text{ K}$ . Because  $V_s < 65.3 \text{ K}$ , then  $S_{\max} = d/2$ , and the  $d/4$  condition does not apply.

Choose no. 3 U-stirrups and calculate the required spacing based on  $V_s$ :

$$S_1 = \frac{A_v f_{yt} d}{V_s} = \frac{0.22(60)(21.5)}{39.3} = 7.26 \text{ in. say, } 7 \text{ in.}$$

Calculate maximum spacing:  $S_2 = 10.5$  in.,  $S_3 = 22$  in., and  $S_4 = 24$  in. and maximum  $S = 10.5$  in. [calculated in (b)].

Because  $S = 7$  in.  $< S_{\max} = 10.5$  in., then use no. 3 U-stirrups spaced at 7 in.

- d. Assume  $V_u = 77 \text{ K} > \phi V_c$ , so stirrups must be provided.

Calculate  $V_s = (V_u - \phi V_c)/\phi = (77 - 24.5)/0.75 = 70 \text{ K}$ .

Check if  $V_s \leq V_{c1} = (4\sqrt{f'_c})b_w d = 65.3 \text{ K}$ . Because  $V_s > 65.3 \text{ K}$ , then  $S_{\max} = d/4 = 12$  in. must be used.

Check if  $V_s \leq V_{c2} = (8\sqrt{f'_c})b_w d = 130.6 \text{ K}$ . Because  $V_{c1} < V_s < V_{c2}$ , then stirrups can be used without increasing the section.

Choose no. 3 U-stirrups and calculate  $S_1$  based on  $V_s$ :

$$S_1 = \frac{A_v f_{yt} d}{V_s} = \frac{0.22(60)(21.5)}{70} = 4.1 \text{ in.} \quad \text{say, 4 in.}$$

Calculate maximum spacings:  $S_2 = d/4 = 21.5/4 = 5.3 \text{ in.}$ , say, 5.0 in.;  $S_3 = 22 \text{ in.}$ ; and  $S_4 = 12 \text{ in.}$  Hence  $S_{\max} = 5\text{-in.}$  controls.

Because  $S = 4 \text{ in.} < S_{\max} = 5 \text{ in.}$ , then use no. 3 stirrups spaced at 4 in.

- e. Assume  $V_u = 128 \text{ K} > \phi V_c$ , so shear reinforcement is required.

Calculate  $V_s = (V_u - \phi V_c)/\phi = (128 - 24.5)/0.75 = 138 \text{ K}$ .

Because  $V_s > V_{c2} = 130.2 \text{ K}$ , the section is not adequate. Increase one or both dimensions of the beam section.

*Notes:* Table 5.2 and Fig. 5.10 can be used to calculate the spacing  $S$  for (c) and (d).

1. For (c),  $V_s = 39.3 \text{ K}$ , from Fig. 5.10 (or Table 5.2 for no. 3 U-stirrups),  $S/d = 0.34$  and  $S_1 = 7.3 \text{ in.}$ , which is less than  $d/2 = 10.5 \text{ in.}$  Note that  $S_{\max}$  based on  $V_s$  is  $d/2$  and not  $d/4$ . Also, from Table 5.1,  $S_3 = A_v f_{yt}/50b_w = 22 \text{ in.}$
2. For (d),  $V_s = 70 \text{ K}$ ,  $S/d = 0.19$  and  $S_1 = 4.1 \text{ in.}$  So  $V_s = 70 > 52.8 \text{ K}$ , and  $S_{\max} = d/4$  is required.

### Example 5.2

A 17-ft-span simply supported beam has a clear span of 16 ft and carries uniformly distributed dead and live loads of 4.5 and 3.75 K/ft, respectively. The dimensions of the beam section and steel reinforcement are shown in Fig. 5.12. Check the section for shear and design the necessary shear reinforcement. Given  $f'_c = 3 \text{ ksi}$  normal-weight concrete and  $f_{yt} = 60 \text{ ksi}$ .

#### Solution

Given:  $b_w$  (web) = 14 in. and  $d = 22.5 \text{ in.}$

1. Calculate factored shear from external loading:

$$\text{Factored uniform load} = 1.2(4.5) + 1.6(3.75) = 11.4 \text{ K/ft}$$

$$V_u (\text{at face of support}) = \frac{11.4(16)}{2} = 91.2 \text{ K}$$

Design  $V_u$  (at distance  $d$  from the face of the support) =  $91.2 - 22.5(11.4)/12 = 69.83 \text{ K}$ .

2. Calculate  $\phi V_c$ :

$$\phi V_c = \phi(2\lambda\sqrt{f'_c})b_w d = \frac{0.75(2)(1)(\sqrt{3000})(14)(22.5)}{1000} = 25.88 \text{ K}$$

$$\frac{1}{2}\phi V_c = 12.94 \text{ K}$$

Calculate  $V_{c1} = (4\sqrt{f'_c})b_w d = (4\sqrt{3000})(14)(22.5)/1000 = 69 \text{ K}$ . Calculate  $V_{c2} = (8\sqrt{f'_c})b_w d = 138 \text{ K}$ .

3. Design  $V_u = 69.83 \text{ K} > \phi V_c = 25.88 \text{ K}$ ; therefore, shear reinforcement must be provided. The distance  $x'$  at which no shear reinforcement is needed (at  $\frac{1}{2}\phi V_c$ ) is

$$x' = \left( \frac{91.2 - 12.94}{91.2} \right) (8) = 6.86 \text{ ft} = 82 \text{ in.}$$

(from the triangles of the shear diagram, Fig. 5.12).

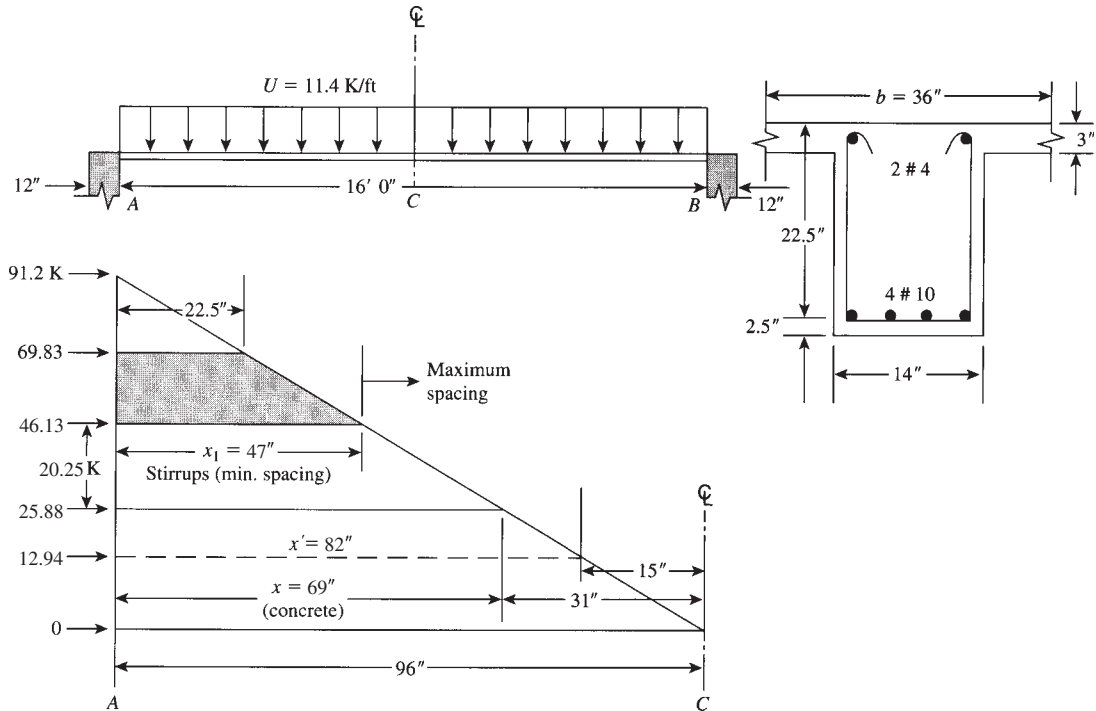


Figure 5.12 Example 5.2.

4. Calculate  $V_s = (V_u - \phi V_c)/\phi = (69.83 - 25.88)/0.75 = 58.6$  K. Because  $V_s$  is less than  $V_{c1} = (4\sqrt{f'_c})b_w d$ , then  $S_{\max} = d/2$  must be considered (or refer to Fig. 5.10 or Table 5.1:  $V_s < 52.8$  K).
5. Design of stirrups: Choose no. 3 U-stirrups,  $A_v = 2(0.11) = 0.22$  in.<sup>2</sup> Calculate  $S_1$  based on  $V_s = 58.6$  K,  $S_1 = A_v f_y d / V_s = 13.2d / V_s = 5.07$  in., say, 5 in. (or get  $s/d = 0.225$  from Table 5.2 or Fig. 5.10).
6. Calculate maximum spacings:  $S_2 = d/2 = 22.5/2 = 11.25$  in., say, 11.0 in.;  $S_3 = A_v f_{yt} / 50b_w = 0.22(60,000) / 50(14) = 18.9$  in. (or use Table 5.1);  $S_4 = 24$  in.;  $S_{\max} = 11$ -in. controls.
7. Because  $S_1 = 5$  in.  $< S_{\max} = 11$  in., use no. 3 U-stirrups spaced at 5 in.
8. Calculate  $V_s$  for maximum spacings of 11 in.:

$$V_s = \frac{A_v f_{yt} d}{S} = \frac{0.22(60)(22.5)}{11} = 27 \text{ K}$$

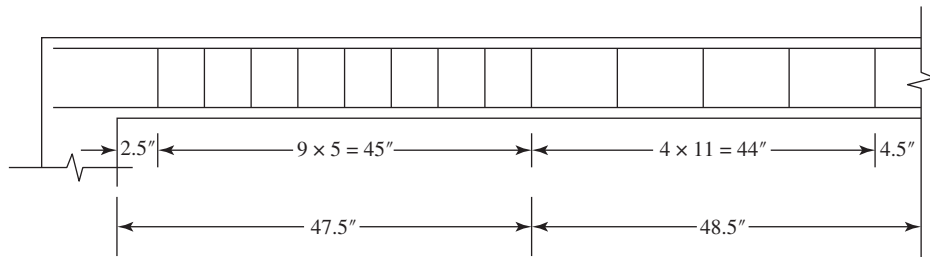
$$\phi V_s = 20.25 \text{ K}$$

$$\phi V_c + \phi V_s = 25.88 + 20.25 = 46.13 \text{ K}$$

The distance  $x_1$  at which  $S = 11$  can be used is

$$\left( \frac{91.2 - 46.13}{91.2} \right) (96) = 47 \text{ in.}$$

Because  $x_1$  is relatively small, use  $S = 5$  in. for a distance  $\geq 47$  and then use  $S = 11$  for the rest of the beam. *Note:* If  $x_1$  is long, then an intermediate spacing between 5 and 11 in. may be added.



**Figure 5.13** Example 5.2: Distribution of stirrups.

9. Distribute stirrups as follows: Place the first stirrup at  $S/2$  from the face of the support.

First stirrup at  $S/2 = 5/2 = 2$  in.

Nine stirrups at  $S = 5 = 45$  in.

Total =  $45 + 2$  in. = 47 in.

Four stirrups at  $S = 11 = 44$  in.

Total = 91 in. > 82 in. (minimum length required).

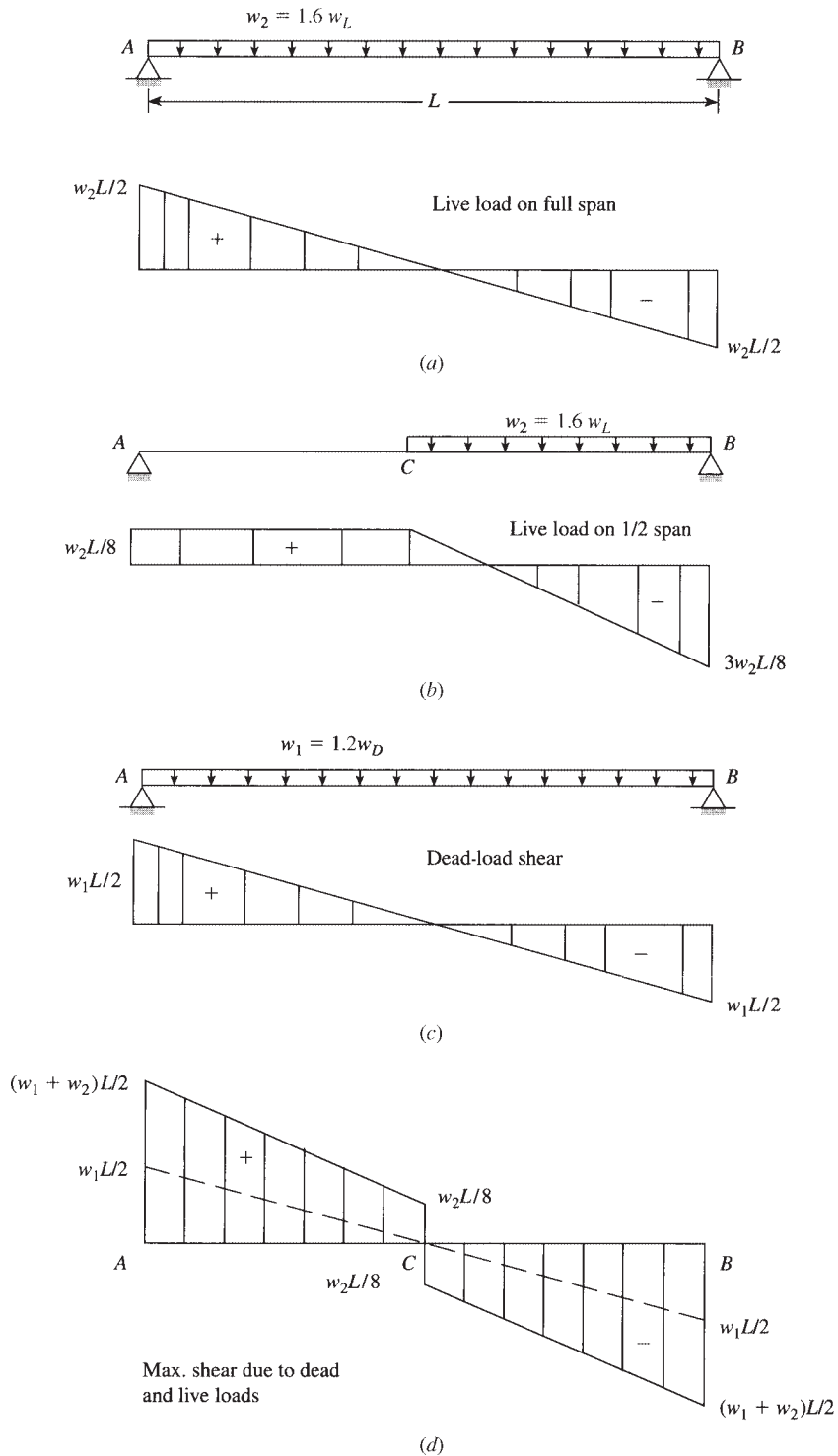
The total number of stirrups for the beam is  $2(1 + 9 + 4) = 28$ . Distribution of stirrups is shown in Fig. 5.13, whereas calculated shear forces are shown in Fig. 5.12.

10. Place two no. 4 bars at the top of the beam section to act as stirrup hangers.

## 5.9 SHEAR FORCE DUE TO LIVE LOADS

In Example 5.2, it was assumed that the dead and live loads are uniformly distributed along the full span, producing zero shear at midspan. Actually, the dead load does exist along the full span, but the live load may be applied to the full span or part of the span, as needed to develop the maximum shear at midspan or at any specific section. Figure 5.15a shows a simply supported beam with a uniform load acting on the full span. The shear force varies linearly along the beam, with maximum shear acting at support A.

In the case of live load,  $W_2 = 1.6W_L$ , the maximum shear force acts at support A when  $W_2$  is applied on the full span, Fig. 5.14a. The maximum shear at midspan develops if the live load is placed on half the beam, BC (Fig. 5.14b), producing  $V_u$  at midspan equal to  $W_2L/8$ . Consequently, the design shear force is produced by adding the maximum shear force due to the live load (placed at different lengths of the span) to the dead-load shear force (Fig. 5.14c) to give the shear distribution shown in Fig. 5.14d. It is common practice to consider the maximum shear at support A to be  $W_uL/2 = (1.2W_D + 1.6W_L)L/2$ , whereas  $V_u$  at midspan is  $W_2L/8 = (1.6W_L)L/8$  with a straight-line variation along AC and CB, as shown in Fig. 5.14d. The design for shear in this case will follow the same procedure explained in Example 5.2. If the approach is applied to the beam in Example 5.2, then  $V_u$  (at A) = 91.2 K and  $V_u$  (at midspan) =  $(1.6 \times 3)(16/8) = 10$  K.



**Figure 5.14** Effect of live-load application on part of the span.

**Example 5.3**

A 10-ft-span cantilever beam has a rectangular section and carries uniform and concentrated factored loads (self-weight is included), as shown in Fig. 5.15. Using  $f'_c = 4$  ksi normal-weight concrete and  $f_y = 60$  ksi, design the shear reinforcement required for the entire length of the beam according to the ACI Code.

**Solution**

1. Calculate the shear force along the beam due to external loads:

$$V_u(\text{at support}) = 5.5(10) + 20 + 8 = 83 \text{ K}$$

$$V_{ud}(\text{at } d \text{ distance}) = 83 - 5.5 \left( \frac{20.5}{12} \right) = 73.6 \text{ K}$$

$$V_u(\text{at 4 ft left}) = 83 - 4(5.5) = 61 \text{ K}$$

$$V_u(\text{at 4 ft right}) = 61 - 20 = 41 \text{ K}$$

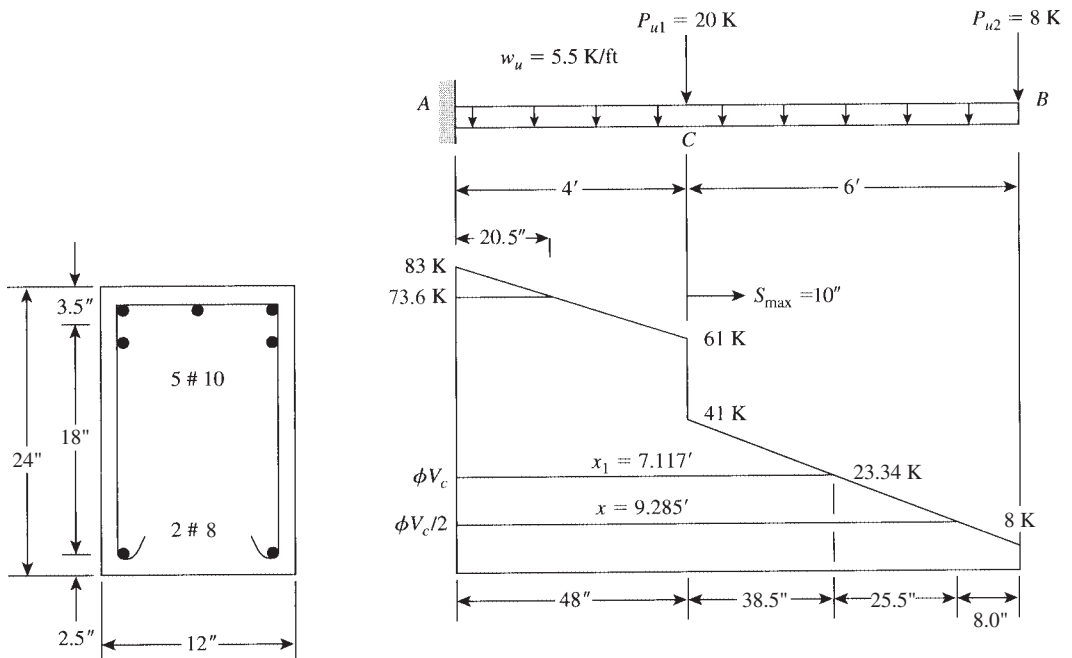
$$V_u(\text{at freeend}) = 8 \text{ K}$$

The shear diagram is shown in Fig. 5.15.

2. Calculate  $\phi V_c$ :

$$\phi V_c = 2\lambda\sqrt{f'_c}bd = 2(0.75)(1)\sqrt{4000}(12)(20.5) = 23.34 \text{ K}$$

$$\frac{1}{2}\phi V_c = 11.67 \text{ K}$$



**Figure 5.15** Example 5.3.

Because  $V_{ud} > \phi V_c$ , shear reinforcement is required. Calculate

$$V_{c1} = 4\sqrt{f'_c}bd = 4\sqrt{4000}(12)(20.5) = 62.2 \text{ K}$$

$$V_{c2} = 8\sqrt{f'_c}bd = 2V_{c1} = 124.4 \text{ K}$$

The distance  $x$  at which no shear reinforcement is needed (at  $\frac{1}{2}\phi V_c = 11.67 \text{ K}$ ) measured from support  $A$  is given as

$$x = 4 + \left( \frac{41 - 11.67}{41 - 8} \right) 6 = 9.33 \text{ ft} = 112 \text{ in.}$$

(8.0 in. from the free end). Similarly,  $x_1$  for  $\phi V_c$  is 7.21 ft from  $A$  (33.5 in. from the free end).

3. Part AC: Design shear  $V_u = V_{ud} = 73.6 \text{ K}$ . Calculate  $V_s = (V_u - \phi V_c)/\phi = (73.6 - 23.34)/0.75 = 67 \text{ K}$ . Because  $V_{c1} < V_s < V_{c2}$ ,  $S_{\max} \leq d/4$  must be considered (or check Fig. 5.10).
4. Design stirrups: Choose no. 3 U-stirrups,  $A_v = 0.22 \text{ in.}^2$  Calculate  $S_1$  (based on  $V_s$ ):

$$S_1 = \frac{A_v f_{yt} d}{V_s} = \frac{13.2d}{V_s} = \frac{13.2(20.5)}{67} = 4.0 \text{ in.}$$

Use 4.0 in. (or get  $s/d = 0.22$  from Fig. 5.10).

5. Calculate maximum spacings:  $S_2 = d/4 = 20.5/4 = 5.12 \text{ in.}$ , so use 5.0 in:

$$S_3 = \frac{A_v f_{yt}}{50b_w} = 22 \text{ in.} \quad (\text{from Table 5.1 for } b = 12 \text{ in.})$$

$$S_4 = 12 \text{ in.}$$

Then  $S_{\max} = 5.0 \text{ in.}$

6. Because  $S = 4 \text{ in.} < S_{\max} = 5.1 \text{ in.}$ , use no. 3 stirrups spaced at 4 in.
7. At  $C$ , design shear  $V_u = 61 \text{ K} > \phi V_c$ . Then  $V_s = (61 - 23.34)/0.75 = 50.2 \text{ K}$ ,  $S_1 = A_v f_{yt} d / V_s = 5.4 \text{ in.}$ :

$$V_s = 50.2 \text{ K} < V_{c1} = 62.2 \text{ K} \quad S_2 = \frac{d}{2} = \frac{20.5}{2} = 10.25 \text{ in.} \quad (\text{or } 10 \text{ in.})$$

Assume  $S_1 = 5.4 \text{ in.} < S_2$ ; then  $S_1 = 5.4$  or 5.0-in. controls.

8. Because spacings of 5.5 and 4.0 in. are close, use no. 3 U-stirrups spaced at 4 in. for part AC.
9. Part BC:

a.

$$V_u = 41 \text{ K} > \phi V_c$$

$$V_s = (V_u - \phi V_c)/\phi = \frac{41 - 23.34}{0.75} = 23.55 \text{ K} < V_{c1} = 62.2 \text{ K}$$

b.  $S_1 = A_v f_{yt} d / V_s = (13.2)(20.5)/23.55 = 11.5 \text{ in.}$

c.  $S_2 = d/2 = 20.5/2 = 10.25 \text{ in.}$  (or less than  $S_3 = 22 \text{ in.}$  or  $S_4 = 24 \text{ in.}$ ). Let  $S_{\max} = 10 \text{ in.}$   
Choose no. 3 stirrups spaced at 10 in. for part BC.

10. Distribution of stirrups measured from support  $A$ : Place the first stirrup at

$$\frac{1}{2}S = \frac{4}{2} = 2 \text{ in.}$$

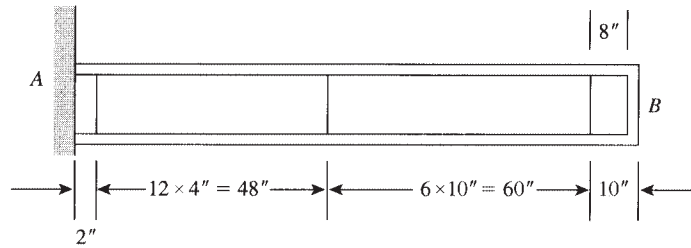
$$12 \times 4 \text{ in.} = \underline{48 \text{ in.}}$$

$$50 \text{ in.}$$

$$6 \times 10 \text{ in.} + 1 \times 8 \text{ in.} = \underline{68 \text{ in.}}$$

$$\text{Total } 118 \text{ in.}$$





**Figure 5.16** Example 5.3: Distribution of stirrups.

Distance left to the free end is 2 in., which is less than 8.0 in., where no stirrups are needed. Distribution of stirrups is shown in Fig. 5.16. Total number of stirrups is 20.

## 5.10 SHEAR STRESSES IN MEMBERS OF VARIABLE DEPTH

The shear stress,  $v$ , is a function of the effective depth,  $d$ ; therefore, shear stresses vary along a reinforced concrete beam with variable depth [10]. In such a beam (Fig. 5.17), consider a small element  $dx$ . The compression force  $C$  at any section is equal to the moment divided by its arm, or  $C = M/y$ . The first derivative of  $C$  is

$$dC = \frac{y dM - M dy}{y^2}$$

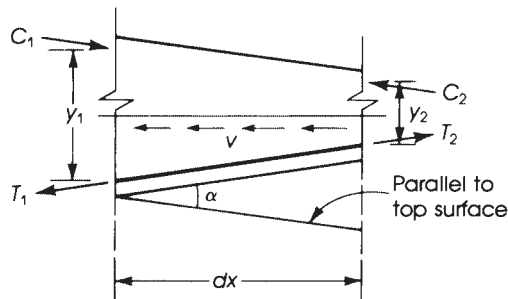
If  $C_1 > C_2$ , then  $C_1 - C_2 = dC = vb dx$ :

$$vb dx = \frac{y dM - M dy}{y^2} = \frac{dM}{y} - \frac{M}{y^2} dy$$

$$v = \frac{1}{yb} \left( \frac{dM}{dx} \right) - \frac{M}{by^2} \left( \frac{dy}{dx} \right)$$

Because  $y = jd$ ,  $dM/dx$  is equal to the shearing force  $V$  and  $d(jd)/dx$  is the slope,

$$v = \frac{V}{bjd} - \frac{M}{b(jd)^2} \left[ \frac{d}{dx} (jd) \right] \quad \text{and} \quad v = \frac{V}{bjd} \pm \frac{M}{b(jd)^2} (\tan \alpha) \quad (5.26)$$



**Figure 5.17** Shear stress in beam with variable depth.

where  $V$  and  $M$  are the external shear and moment, respectively, and  $\alpha$  is the slope angle of one face of the beam relative to the other face. The plus sign is used when the beam depth decreases as the moment increases, whereas the minus sign is used when the depth increases as the moment increases. This formula is used for small slopes, where the angle  $\alpha \leq 30^\circ$ .

A simple form of Eq. 5.26 can be formed by eliminating the  $j$  value:

$$v = \frac{V}{bd} \pm \frac{M}{bd^2}(\tan\alpha) \quad (5.27)$$

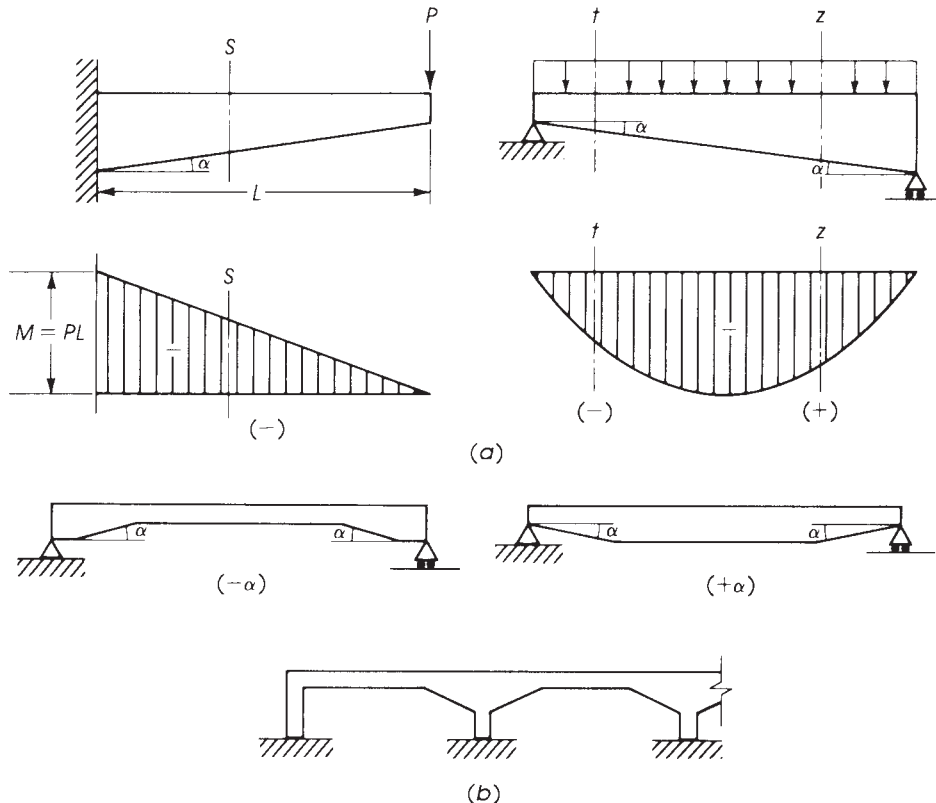
For the strength design method, the following equation may be used:

$$v_u = \frac{V_u}{\phi bd} \pm \frac{M_u}{\phi bd^2}(\tan\alpha) \quad (5.28)$$

For the shearing force,

$$\phi V_n = V_u \pm \frac{M_u}{d}(\tan\alpha) \quad (5.29)$$

Figure 5.18 shows a cantilever beam with a concentrated load  $P$  at the free end. The moment and the depth  $d$  increase toward the support. In this case a negative sign is used in Eqs. 5.27, 5.28, and 5.29. Similarly, a negative sign is used for section  $t$  in the simply supported beam shown, and a positive sign is used for section  $Z$ , where the moment increases as the depth decreases.



**Figure 5.18** Beams with variable depth: (a) moment diagrams and (b) typical forms.

In many cases, the variation in the depth of beams occurs on parts of the beams near their supports (Fig. 5.18).

Tests [11] on beams with variable depth indicate that beams with greater depth at the support fail mainly by shear compression. Beams with smaller depth at the support fail generally by an instability type of failure, caused by the propagation of the major crack in the beam upward and then horizontally to the beam's top section. Tests also indicate that for beams with variable depth (Fig. 5.18) with an inclination  $\alpha$  of about  $10^\circ$  and subjected to shear and flexure, the concrete shear strength,  $V_{cv}$ , may be computed by

$$V_{cv} = V_c(1 + \tan \alpha) \quad (5.30)$$

where

$V_{cv}$  = shear strength of beam with variable depth

$V_c$  = ACI Code, Eq. 11

$$= [1.9\lambda\sqrt{f'_c} + 2500\rho_w(V_u d_s/M_u)]b_w d_s \leq 3.5\lambda\sqrt{f'_c}b_w d_s$$

$\alpha$  = angle defining orientation of reinforcement, considered positive for beams of small depth at support and negative for beams with greater depth at support (Fig. 5.18)

$d_s$  = effective depth of beam at support

The simplified ACI Code, Eq. 11.5, can also be used to compute  $V_c$ :

$$V_c = (2\lambda\sqrt{f'_c})b_w d_s \quad (5.31)$$

#### Example 5.4

Design the cantilever beam shown in Fig. 5.19 under the factored loads applied if the total depth at the free end is 12 in., and it increases toward the support. Use a steel percentage  $\rho = 1.5\%$ ,  $f'_c = 4$  ksi normal-weight concrete,  $f_y = 60$  ksi, and  $b = 10$  in.

#### Solution

1. Let  $M_u$  (support) =  $(2.5/2)(8)^2(12) + (14)(8)(12) = 2304$  K · in.

2. For  $\rho = 1.5\%$ ,  $R_u = \phi\rho f_y \left(1 - \frac{\rho f_y}{1.7f'_c}\right) = 703$  psi

$$d = \sqrt{\frac{M}{R_u b}} = \sqrt{\frac{2304}{0.703 \times 10}} = 18.1 \text{ in.}$$

Assume  $A_s = 0.015 \times 10 \times 18.1 = 2.72$  in.<sup>2</sup> (use three no. 9 bars); let actual  $d = 19.5$  in.,  $h = 22$  in.

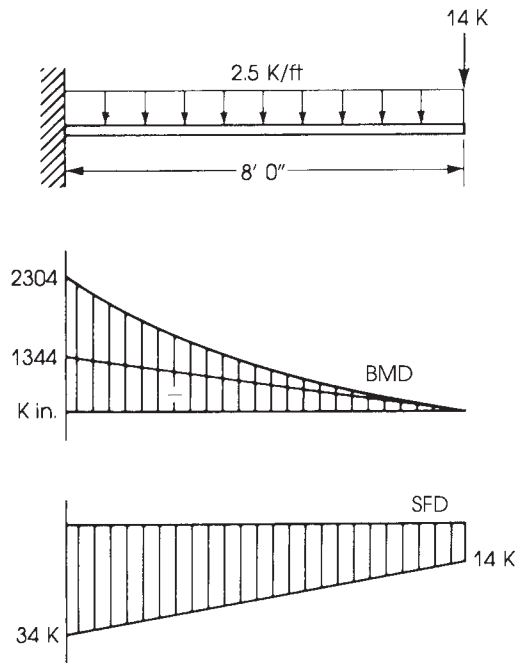
3. Design for shear: Maximum shear at the support is  $14 + 20 = 34$  K. Because the beam section is variable, the moment effect shall be considered; because the beam depth increases as the moment increases, a minus sign is used in Eq. 5.28,

$$v_u = \frac{V_u}{\phi b d} - \frac{M_u}{\phi b d^2} (\tan \alpha)$$

To find  $\tan \alpha$ , let  $d$  at the free end be 9.5 in. and  $d$  at the support be 19.5 in.:

$$\tan \alpha = \frac{19.5 - 9.5}{8 \times 12} = 0.1042$$

$$\begin{aligned} v_u(\text{at support}) &= \frac{34,000}{0.75 \times 10 \times 19.5} - \frac{2304 \times 1000 \times 0.1042}{0.75 \times 10 \times (19.5)^2} \\ &= 148 \text{ psi} \end{aligned}$$



**Figure 5.19** Bending moment diagram (middle) and shear force diagram (bottom).

4. Shear stress at the free end is  $V_u/\phi bd (M_u = 0)$ ,

$$v_u = \frac{14,000}{0.75 \times 10 \times 9.5} = 196 \text{ psi}$$

5. At a distance 18 in. from the face of the support, the effective depth is 17.6 in. (from geometry),

$$V_u = 34 - 2.5 \times \frac{18}{12} = 30.25 \text{ K}$$

$$\begin{aligned} M_u(\text{at 18 in. from support}) &= 14 \times 78 + \frac{2.5}{12} \times \frac{(78)^2}{2} \\ &= 1726 \text{ K} \cdot \text{in.} \end{aligned}$$

$$\begin{aligned} v_u &= \frac{30.25 \times 1000}{0.75 \times 10 \times 17.6} - \frac{1726 \times 1000 \times 0.1042}{0.75 \times 10 \times (17.6)^2} \\ &= 152 \text{ psi} \end{aligned}$$

6. At midspan (48 in. from the support),

$$d = 14.5 \text{ in.}$$

$$V_u = 14 + 10 = 24 \text{ K}$$

$$M_u = 14 \times 48 + \frac{2.5}{12} \times \frac{(48)^2}{2} = 912 \text{ K} \cdot \text{in.}$$

$$v_u = \frac{24,000}{0.75 \times 10 \times 14.5} - \frac{912 \times 1000 \times 0.1042}{0.75 \times 10 \times (14.5)^2} = 160 \text{ psi}$$

Similarly, at 6 ft from the support (2 ft from the free end), E67

7. The shear stress resisted by concrete is

$$2\lambda\sqrt{f'_c} = (2)(1)\sqrt{4000} = 126.5 \text{ psi}$$

The minimum shear stress to be resisted by shear reinforcement is

$$v_s = 196 - 126.6 = 69.5 \text{ psi}$$

( $V_u$  and consequently  $v_s$  have already been increased by the ratio  $1/\phi$  in Eq. 5.28).

8. Choose no. 3 stirrups with two legs:

$$A_v = 2 \times 0.11 = 0.22 \text{ in.}^2$$

$$S \text{ (required)} = \frac{A_v f_{yt}}{v_s b_w} = \frac{0.22 \times 60,000}{69.5 \times 10} = 19 \text{ in.}$$

$$S_{\max} \text{ (for } d/2 \text{ at fixed end)} = 9.75 \text{ in.} \quad \text{to} \quad S_{\max} = 4.75 \text{ in. at free end}$$

$$S_{\max} \text{ (for minimum } A_v) = \frac{A_v f_{yt}}{50b_w} = \frac{0.22 \times 60,000}{50 \times 10} = 26.4 \text{ in.}$$

9. Check for maximum spacing ( $d/4$ ):  $v_{us} \leq 4\sqrt{f'_c}$ ,

$$4\sqrt{f'_c} = (4)\sqrt{4000} = 253 > 69.5 \text{ in.}$$

10. Distribution of stirrups (distances from free end):

$$1 \text{ stirrup at } 2 \text{ in.} = 2 \text{ in.}$$

$$10 \text{ stirrups at } 4.5 \text{ in.} = 45 \text{ in.}$$

$$3 \text{ stirrups at } 7 \text{ in.} = 21 \text{ in.}$$

$$3 \text{ stirrups at } 8 \text{ in.} = \underline{24 \text{ in.}}$$

$$\text{Total} = 92 \text{ in.}$$

There is 4 in. left to the face of the support.

## 5.11 EXAMPLES USING SI UNITS

The general design requirements for shear reinforcement according to the ACI Code are summarized in Table 5.4, which gives the necessary design equations in both U.S. customary and SI units. The following example shows the design of shear reinforcement using SI units.

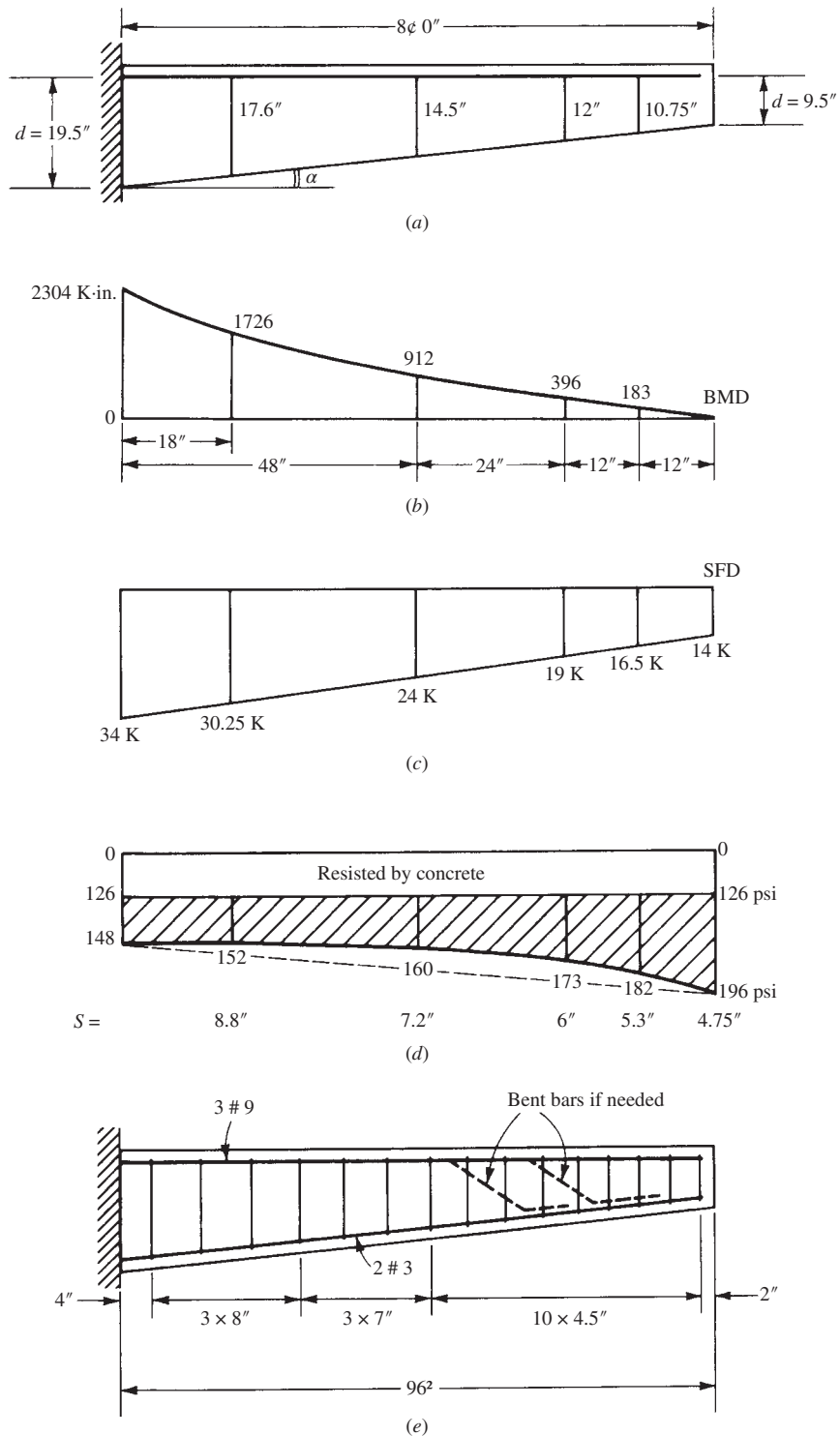


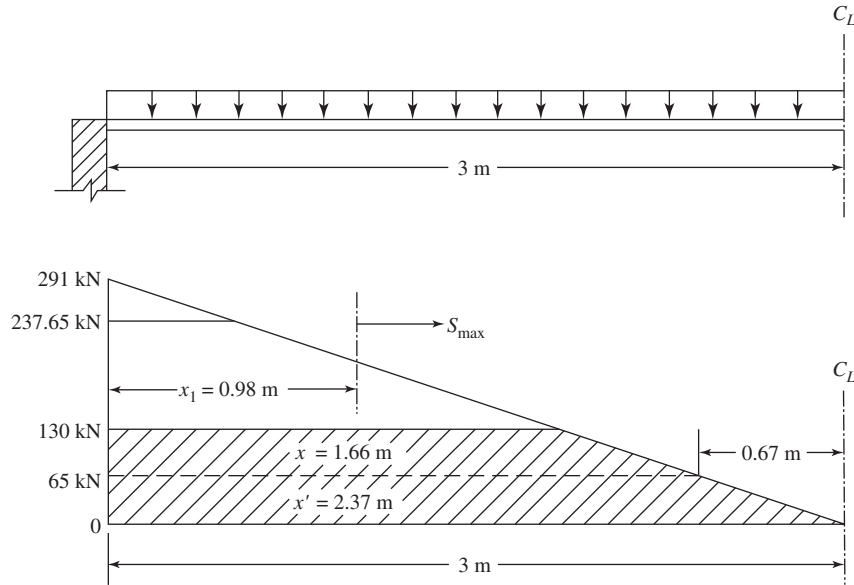
Figure 5.20 Example 5.4: Web reinforcement for beam of variable depth.

**Table 5.4** Shear Reinforcement Formulas

U.S. Customary Units	SI Units
$V_u$ = design shear	$V_u$ = design shear
Maximum design $V_u$ at distance $d$ from face of support.	
$V_c = (2.0\lambda\sqrt{f'_c}) b_w d$	$V_c = (0.17\lambda\sqrt{f'_c}) b_w d$
$V_c = \left[ 1.9\lambda\sqrt{f'_c} + \left( 2500\rho_w \frac{V_u d}{M_u} \right) \right] b_w d$	$V_c = \left[ 0.16\lambda\sqrt{f'_c} + \left( 17.2\rho_w \frac{V_u d}{M_u} \right) \right] b_w d$
$\rho_w = \frac{A_s}{b_w d} \frac{V_u d}{M_u} \leq 1.0$	$\rho_w = \frac{A_s}{b_w d} \frac{V_u d}{M_u} \leq 1.0$
$V_c \leq (3.5\lambda\sqrt{f'_c}) b_w d$	$V_c \leq (0.29\lambda\sqrt{f'_c}) b_w d$
$V_u = \phi V_c + \phi V_s$	$V_u = \phi V_c + \phi V_s$
Vertical stirrups	
$\phi V_s = V_u - \phi V_c$	$\phi V_s = V_u - \phi V_c$
$S = A_v f_{yt} d / V_s$	$S = A_v f_{yt} d / V_s$
Minimum $A_v = \frac{50b_w S}{f_{yt}} \leq 0.75\sqrt{f'_c} \left( \frac{b_w S}{f_{yt}} \right)$	Minimum $A_v = \frac{0.35b_w S}{f_{yt}} \leq 0.0062\sqrt{f'_c} \left( \frac{b_w S}{f_y} \right)$
Maximum $S = \frac{A_v f_{yt}}{50b_w} \geq \frac{A_v f_{yt}}{0.75\sqrt{f'_c} b_w}$	Maximum $S = \frac{A_v f_{yt}}{0.35b_w} \geq \frac{A_v f_y}{0.062\sqrt{f'_c} b_w}$
For vertical web reinforcement	
Maximum $S = \frac{1}{2}d \leq 24$ in.	Maximum $S = \frac{1}{2}d \leq 600$ mm
If $V_s \leq 4.0\sqrt{f'_c} (b_w d)$	If $V_s \leq 0.33\sqrt{f'_c} (b_w d)$
Maximum $S = d/4 = 12$ in.	Maximum $S = d/4 = 300$ mm
If $V_s > 4.0\sqrt{f'_c} (b_w d)$	If $V_s > 0.33\sqrt{f'_c} (b_w d)$
$V_s \leq 8\sqrt{f'_c} (b_w d)$	$V_s \leq 0.67\sqrt{f'_c} (b_w d)$
Otherwise increase the dimensions of the section.	
Series of bent bars or inclined stirrups	
$A_v = \frac{V_s S}{f_{yt} d (\sin \alpha + \cos \alpha)}$	$A_v = \frac{V_s S}{f_{yt} d (\sin \alpha + \cos \alpha)}$
For $\alpha = 45^\circ$ , $S = 1.4A_v f_y d / V_s$	For $\alpha = 45^\circ$ , $S = 1.4A_v f_y d / V_s$
For single bent bar or group of bars, parallel and bent in one position	
$A_v = \frac{V_s}{f_{yt} \sin \alpha}$	$A_v = \frac{V_s}{f_{yt} \sin \alpha}$
For $\alpha = 45^\circ$ , $A_v = 1.4V_s / f_{yt}$	For $\alpha = 45^\circ$ , $A_v = 1.4V_s / f_{yt}$
$V_s \leq (3\sqrt{f'_c}) b_w d$	$V_s \leq (0.25\sqrt{f'_c}) b_w d$

**Example 5.5**

A 6-m clear-span simply supported beam carries a uniform dead load of 47.5 kN/m and a live load of 25 kN/m (Fig. 5.21). The dimensions of the beam section are  $b = 350$  mm,  $d = 550$  mm. The beam is reinforced with four bars 25 mm diameter in one row. It is required to design the necessary shear reinforcement. Given:  $f'_c = 28$  MPa and  $f_y = 280$  MPa.



**Figure 5.21** Example 5.5.

**Solution**

1. Factored load is

$$1.2D + 1.6L = 1.2 \times 47.5 + 1.6 \times 25 = 97 \text{ kN/m}$$

2. Factored shear force at the face of the support is

$$V_u = 97 \times \frac{6}{2} = 291 \text{ kN}$$

3. Maximum design shear at a distance  $d$  from the face of the support is

$$V_u \text{ (at distance } d) = 291 - 0.55 \times 97 = 237.65 \text{ kN}$$

4. The nominal shear strength provided by the concrete is

$$V_c = (0.17\lambda\sqrt{f'_c})bd = (0.17\sqrt{28}) \times 350 \times 550 = 173.2 \text{ kN}$$

$$V_u = \phi V_c + \phi V_s$$

$$\phi V_c = 0.75 \times 173.2 = 130 \text{ kN}$$

$$\frac{1}{2}\phi V_c = 65 \text{ kN}$$

$$\phi V_s = 237.65 - 130 = 107.65 \text{ kN}$$

$$V_s = \frac{107.65}{0.75} = 143.5 \text{ kN}$$



5. Distance from the face of the support at which  $\frac{1}{2}\phi V_c = 65$  kN is

$$x' = \frac{291 - 65}{291}(3) = 2.33 \text{ m} \quad (\text{from triangles})$$

6. Design of stirrups:

- a. Choose stirrups 10 mm in diameter with two branches ( $A_s = 78.5 \text{ mm}^2$ ).

$$A_v = 2 \times 78.5 = 157 \text{ mm}^2$$

$$\text{Spacing } S_1 = \frac{A_v f_{yt} d}{V_s} = \frac{157 \times 280 \times 550}{143.5 \times 10^3} = 168.5 \text{ mm} < 600 \text{ mm}$$

- b. Check for maximum spacing of  $d/4$ :

$$S_{\max} = \begin{cases} \frac{1}{2}d & \text{for } V_s \leq (0.33\sqrt{f'_c})bd \\ \frac{1}{4}d & \text{for If } V_s > (0.33\sqrt{f'_c})bd \end{cases}$$

$$bd(0.33\sqrt{f'_c}) = 0.33\sqrt{28} \times 350 \times 550 = 336.1 \text{ kN}$$

Actual  $V_s = 143.5 \text{ kN} < 336.1 \text{ kN}$ . Therefore,  $S_{\max}$  is limited to  $d/2 = 275 \text{ mm}$ .

7. The shear reinforcement, stirrups 10 mm in diameter and spaced at 160 mm, will be needed only for a distance  $d = 0.55 \text{ m}$  from the face of the support. Beyond that, the shear stress  $V_s$  decreases to zero at a distance  $x = 1.66 \text{ m}$  when  $\phi V_c = 130 \text{ kN}$ . It is not practical to provide stirrups at many different spacings. One simplification is to find out the distance from the face of the support where maximum spacing can be used and then only two different spacings may be adopted:

$$\text{Maximum spacing} = \frac{1}{2}d = 275 \text{ mm}$$

$$V_s(\text{for } s_{\max} = 275 \text{ mm}) = \frac{A_v f_{yt} d}{S} = \frac{157 \times 0.280 \times 550}{275} = 87.9 \text{ kN}$$

$$\phi V_s = 87.9 \times 0.75 = 65.94 \text{ kN}$$

The distance from the face of the support where  $S_{\max} = 275 \text{ mm}$  can be used (from the triangles):

$$x_1 = \frac{291 - (130 + 65.94)}{291}(3) = 0.98 \text{ m}$$

Then, for 0.98 m from the face of the support, use stirrups 10 mm in diameter at 160 mm, and for the rest of the beam, minimum stirrups (with maximum spacing) can be used.

8. Distribution of stirrups:

$$\text{One stirrup at } \frac{S}{2} = \frac{160}{2} = 80 \text{ mm}$$

$$\text{Six stirrups at } 160 \text{ mm} = \underline{960 \text{ mm}}$$

$$\text{Total} = 1040 \text{ mm} = 1.04 \text{ m} > 0.98 \text{ m}$$

$$\text{Six stirrups at } 270 \text{ mm} = \underline{1620 \text{ mm}}$$

$$\text{Total} = 2660 \text{ mm} = 2.66 \text{ m} < 3 \text{ m}$$

The last stirrup is  $3 - 2.66 = 0.34 \text{ m} = 340 \text{ mm}$  from the centerline of the beam, which is adequate. A similar stirrup distribution applies to the other half of the beam, giving a total number of stirrups of 28.

The other examples in this chapter can be worked out in a similar way using SI equations.

**SUMMARY****Sections 5.1 and 5.2**

The shear stress in a homogeneous beam is  $v = VQ/Ib$ . The distribution of the shear stress above the neutral axis in a singly reinforced concrete beam is parabolic. Below the neutral axis, the maximum shear stress is maintained down to the level of the steel bars.

**Section 5-3**

The development of shear resistance in reinforced concrete members occurs by:

- Shear resistance of the uncracked concrete
- Interface shear transfer
- Arch action
- Dowel action

**Section 5-4**

The shear stress at which a diagonal crack is expected is

$$v_c = \frac{V}{bd} = \left( 1.9\lambda\sqrt{f'_c} + 2500\rho_w \frac{V_u d}{M_u} \right) \leq 3.5\sqrt{f'_c}$$

The nominal shear strength is

$$V_c = v_c b_w d = 2\lambda\sqrt{f'_c} b_w d$$

**Sections 5.5 and 5.6**

1. The common types of shear reinforcement are stirrups (perpendicular or inclined to the main bars), bent bars, or combinations of stirrups and bent bars:

$$V_u = \phi V_n = \phi V_c + \phi V_s \quad \text{and} \quad V_s = \frac{1}{\phi}(V_u - \phi V_c)$$

2. The ACI Code design requirements are summarized in Table 5.4.

**Sections 5.7 and 5.8**

Design of vertical stirrups and shear summary are given in these sections.

**Sections 5.9 and 5.10**

1. Variation of shear force along the span due to live load may be considered.
2. For members with variable depth,

$$\phi V_n = V_u \pm \frac{M_u(\tan \alpha)}{d}$$

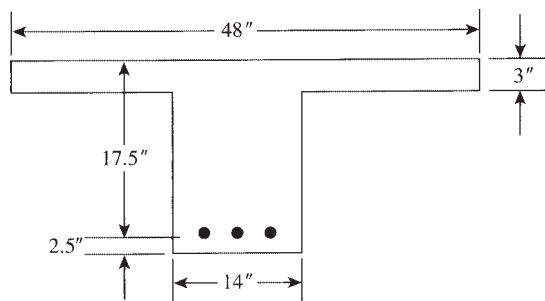
**REFERENCES**

1. "Report of the ACI-ASCE Committee 326." *ACI Journal* 59 (1962), 121 p.
2. ACI-ASCE Committee 426. "The Shear Strength of Reinforced Concrete Members." *ASCE Journal, Structural Division* (June 1973).

3. R. C. Fenwick and T. Paulay. "Mechanisms of Shear Resistance of Concrete Beams." *ASCE Journal, Structural Division* (October 1968).
4. G. N. Kani. "Basic Facts Concerning Shear Failure." *ACI Journal* 63 (June 1966).
5. D. W. Johnson and P. Zia. "Analysis of Dowel Action." *ASCE Journal, Structural Division* 97 (May 1971).
6. H. P. Taylor. "The Fundamental Behavior of Reinforced Concrete Beams in Bending and Shear." In *Shear in Reinforced Concrete*, vol. 1. Special Publication 42. American Concrete Institute, Detroit, MI, 1974.
7. A. L. L. Baker. *Limit-State Design of Reinforced Concrete*. Cement and Concrete Association, London, 1970.
8. P. E. Regan and M. H. Khan. "Bent-Up Bars as Shear Reinforcement." In *Shear in Reinforced Concrete*, vol. 1. Special Publication 42. American Concrete Institute, Detroit, MI, 1974.
9. J. G. MacGregor. "The Design of Reinforced Concrete Beams for Shear." In *Shear in Reinforced Concrete*, vol. 2. Special Publication 42. American Concrete Institute, Detroit, MI, 1974.
10. Deutsches Institute für Normung. *German Code of Practice*. DIN 1045.
11. S. Y. Debaiky and E. I. Elniema. "Behavior and Strength of Reinforced Concrete Beams in Shear." *ACI Journal* 79 (May–June 1982).
12. P. Marti. "Truss Models in Detailing." *Concrete International Design and Construction* 7, no. 12 (December 1985).
13. P. Marti. "Basic Tools of Beam Design." *ACI Journal* 82, no. 1 (January–February 1985).
14. Comité Euro-International du Béton. CEB-FIP Model Code 1990. Thomas Telford, London, 1993.
15. D. M. Rogowsky and J. MacGregor. "Design of Deep R.C. Continuous Beams." *Concrete International* 8, no. 8 (August 1986).
16. American Concrete Institute (ACI) Code. "Building Code Requirements for Structural Concrete." ACI 318-14. ACI, Detroit, MI, 2014.

## PROBLEMS

- 5.1** Design the necessary shear reinforcement (if needed) in the form of U-stirrups (two legs) for the T-section shown in Fig. 5.22. Use  $f'_c = 4$  ksi (28 MPa) and  $f_y = 60$  ksi (420 MPa).
- a.  $V_u = 22$  K (98 kN)
  - b.  $V_u = 56$  K (246 kN)
  - c.  $V_u = 69$  K (306 kN)



**Figure 5.22** Problem 5.1.

- 5.2** Repeat Problem 5.1 for the section shown in Fig. 5.23.

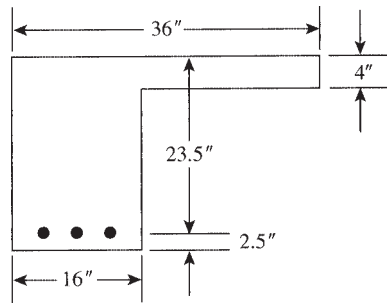


Figure 5.23 Problem 5.2.

- 5.3 Design the necessary shear reinforcement (if needed) in the form of U-stirrups (two legs) for the rectangular section shown in Fig. 5.24 using  $f'_c = 3$  ksi (21 MPa) and  $f_{yt} = 60$  ksi (420 MPa).
- $V_u = 55$  K (245 kN)
  - $V_u = 110$  K (490 kN)
  - $V_u = 144$  K (640 kN)

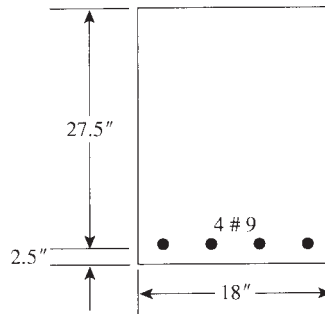


Figure 5.24 Problem 5.3.

- 5.4 A 16-ft- (4.8-m-) span simply supported beam, Fig. 5.25, has a clear span of 15 ft (4.5 m) and is supported by 12 × 12-in. (300 × 300-mm) columns. The beam carries a factored uniform load of 11.1 K/ft (166 kN/m). The dimensions of the beam section and the flexural steel reinforcement are shown in Fig. 5.25. Design the necessary shear reinforcements using  $f'_c = 3$  ksi (21 MPa) and  $f_{yt} = 60$  ksi (420 MPa). Show the distribution of stirrups along the beam.
- 5.5 An 18-ft- (5.4-m-) span simply supported beam carries a uniform dead load of 4 K/ft (60 kN/m) and a live load of 1.5 K/ft (22 kN/m). The beam has a width  $b = 12$  in. (300 mm) and a depth  $d = 24$  in. (600 mm) and is reinforced with six no. 9 bars (6 × 28 mm) in two rows. Check the beam for shear and design the necessary shear reinforcement. Given:  $f'_c = 3$  ksi (21 MPa) and  $f_{yt} = 50$  ksi (280 MPa).
- 5.6 Design the necessary shear reinforcement for a 14-ft (4.2-m) simply supported beam that carries a factored uniform load of 10 K/ft (150 kN/m) (including self-weight) and a factored concentrated load at midspan of  $P_u = 24$  K (108 kN). The beam has a width  $b = 14$  in. (350 mm) and a depth  $d = 16.5$  (400 mm) and is reinforced with four no. 8 bars (4 × 25 mm). Given:  $f'_c = 4$  ksi (28 MPa) and  $f_{yt} = 60$  ksi (420 MPa).
- 5.7 A cantilever beam with 7.4-ft (2.20-m) span carries a uniform dead load of 2.5 K/ft (36 kN/m) (including self-weight) and a concentrated live load of 18 K (80 kN) at a distance of 3 ft (0.9 m) from the face of the support. Design the beam for moment and shear. Given:  $f'_c = 3$  ksi (21 MPa),  $f_{yt} = 60$  ksi (420 MPa), and  $b = 12$  in. (200 mm) and use  $\rho = 3/4\rho_{\max}$ .
- 5.8 Design the critical sections of an 11-ft- (3.3-m-) span simply supported beam for bending moment and shearing forces using  $\rho = 0.016$ . Given:  $f'_c = 3$  ksi (21 MPa),  $f_{yt} = 60$  ksi (420 MPa), and  $b = 10$  in. (250 mm). Dead load is 2.75 K/ft (40 kN/m) and live load is 1.375 K/ft (20 kN/m).

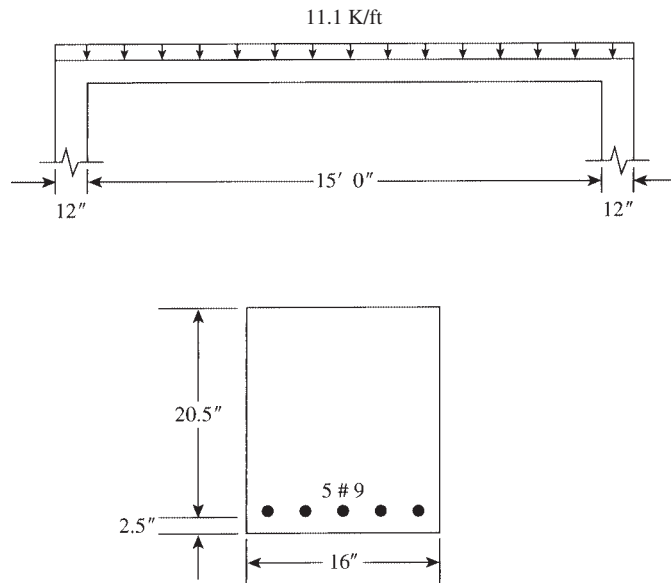


Figure 5.25 Problem 5.4.

- 5.9** A rectangular beam is to be designed to carry a factored shearing force of 75 K (335 kN). Determine the minimum beam section if controlled by shear ( $V_c = 2\lambda\sqrt{f'_c}bd$ ) using the minimum shear reinforcement as specified by the ACI Code and no. 3 stirrups. Given:  $f'_c = 4$  ksi (28 MPa),  $f_{yt} = 40$  ksi (280 MPa), and  $b = 16$  in. (400 mm).
- 5.10** Redesign Problem 5.5 using  $f_{yt} = 60$  ksi.
- 5.11** Redesign the shear reinforcement of the beam in Problem 5.6 if the uniform factored load of 6 K/ft (90 kN/m) is due to dead load and the concentrated load  $P_u = 24$  k (108 kN) is due to a moving live load. Change the position of the live load to cause maximum shear at the support and at midspan.
- 5.12** Design a cantilever beam that has a span of 9 ft (2.7 m) to carry a factored triangular load that varies from zero load at the free end to maximum load of 8 K/ft (120 kN/m) at the face of the support. The beam shall have a variable depth, with minimum depth at the free end of 10 in. (250 mm) and increasing linearly toward the support. Use steel percentage  $\rho = 0.016$  for flexural design. Given:  $f'_c = 4$  ksi (28 MPa),  $f_{yt} = 60$  ksi (420 MPa) or flexural reinforcement,  $f_{yt} = 40$  ksi (280 MPa) for stirrups, and  $b = 11$  in. (275 mm).

## CHAPTER 6

# DEFLECTION AND CONTROL OF CRACKING



High-rise building, Chicago, Illinois.

### 6.1 DEFLECTION OF STRUCTURAL CONCRETE MEMBERS

Flexural concrete members must be designed for safety and serviceability. The members will be safe if they are designed according to the ACI Code equations and limitations. Consequently, as explained in previous chapters, the size of each member is determined as well as the reinforcement required to maintain an internal moment capacity equal to or greater than that of the external moment. Once the final dimensions are determined, the beam must be checked for serviceability: for cracks and deflection. Adequate stiffness of the member is necessary to prevent excessive cracks and deflection.

The use of the ACI Code provisions, taking into consideration the nonlinear relationship between stress and strain in concrete, has resulted in smaller sections than those designed by the elastic theory. The ACI Code, Section 20.2.2.4, recognizes the use of steel up to a yield strength of 100 ksi (690 MPa) and the use of high-strength concrete. The use of high-strength steel and concrete results in smaller sections and a reduction in the stiffness of the flexural member and consequently increases its deflection.

The permissible deflection is governed by many factors, such as the type of the building, the appearance of the structure, the presence of plastered ceilings and partitions, the damage expected due to excessive deflection, and the type and magnitude of live load.

**Table 6.1** Minimum Thickness of Beams and One-Way Slabs ( $L$  = Span Length)

Member	Yield Strength $f_y$ (ksi)	Simply Supported	One End Continuous	Both Ends Continuous	Cantilever
Solid one-way slabs	40	$L/25$	$L/30$	$L/35$	$L/12.5$
	50	$L/22$	$L/27$	$L/31$	$L/11$
	60 <sup>a</sup>	$L/20$	$L/24$	$L/28$	$L/10$
Beams or ribbed one-way slabs	40	$L/20$	$L/23$	$L/26$	$L/10$
	50	$L/18$	$L/20.5$	$L/23.5$	$L/9$
	60 <sup>a</sup>	$L/16$	$L/18.5$	$L/21$	$L/8$

<sup>a</sup> Values reported in ACI Table 9.5(a).

The ACI Code, Sections 7.3.11, specifies minimum thickness for one-way flexural members and one-way slabs, as shown in Table 6.1. The values are for members not supporting or attached to partitions or other constructions likely to be damaged by large deflections.

The minimum thicknesses indicated in Table 6.1 are used for members made of normal-weight concrete and for steel reinforcement with yield strengths as mentioned in the table. The values are modified for cases of lightweight concrete or a steel yield strength different from 60 ksi as follows:

- For lightweight concrete having unit weights in the range of 90 to 115 pcf, the values in the tables for  $f_y = 60$  ksi (420 MPa) shall be multiplied by the greater of  $1.65 - 0.005 W_c$  but not less than 1.09, where  $W_c$  is the unit weight of concrete in pounds per cubic foot.
- For yield strength of steel different from 60 ksi (420 MPa), the values in the tables for 60 ksi shall be multiplied by  $0.4 + f_y/100$ , where  $f_y$  is in ksi.

## 6.2 INSTANTANEOUS DEFLECTION

The deflection of structural members is due mainly to the dead load plus a fraction of or all the live load. The deflection that occurs immediately upon the application of the load is called the *immediate*, or *instantaneous*, *deflection*. Under sustained loads, the deflection increases appreciably with time. Various methods are available for computing deflections in statically determinate and indeterminate structures. The instantaneous deflection calculations are based on the elastic behavior of the flexural members. The elastic deflection,  $\Delta$ , is a function of the load,  $W$ , span,  $L$ , moment of inertia,  $I$ , and modulus of elasticity of the material,  $E$ :

$$\Delta = f \left( \frac{WL}{EI} \right) = \alpha \left( \frac{WL^3}{EI} \right) = K \left( \frac{ML^2}{EI} \right) \quad (6.1)$$

where  $W$  is the total load on the span and  $\alpha$  and  $K$  are coefficients that depend on the degree of fixity at the supports, the variation of moment of inertia along the span, and the distribution of load. For example, the maximum deflection on a uniformly loaded simply supported beam is

$$\Delta = \frac{5WL^3}{384EI} = \frac{5wL^4}{384EI} \quad (6.2)$$

where  $W = wL$  (uniform load per unit length  $\times$  span) is the total load on the span. Deflections of beams with different loadings and different end conditions as a function of the load, span, and  $EI$  are given in Appendix C and in books of structural analysis.

Because  $W$  and  $L$  are known, the problem is to calculate the modulus of elasticity,  $E$ , and the moment of inertia,  $I$ , of the concrete member or the flexural stiffness of the member,  $EI$ .

### 6.2.1 Modulus of Elasticity

The ACI Code, Section 19.2.2, specifies that the modulus of elasticity of concrete,  $E_c$ , may be taken as

$$E_c = 33w_c^{1.5}\sqrt{f'_c}\text{psi} \quad (6.3)$$

for values of  $w_c$  between 90 and 160 pcf. For normal-weight concrete ( $W_c = 145$  pcf),

$$E_c = 57,600\sqrt{f'_c}\text{psi} \quad (\text{or ACI recommends } 57,000\sqrt{f'_c})$$

The modulus of elasticity is usually determined by the short-term loading of a concrete cylinder. In actual members, creep due to sustained loading, at least for the dead load, affects the modulus on the compression side of the member. For the tension side, the modulus in tension is assumed to be the same as in compression when the stress magnitude is low. At high stresses the modulus decreases appreciably. Furthermore, the modulus varies along the span due to the variation of moments and shear forces.

### 6.2.2 Modular Ratio

The modular ratio,  $n = Es/E_c$ , which is used in the transformed area concept, was explained in Section 2.10. It may be used to the nearest whole number but may not be less than 6. For example:

$$\text{When } f'_c = 2500 \text{ psi (17.5 MPa), } n = 10.$$

$$\text{When } f'_c = 3000 \text{ psi (20 MPa), } n = 9.$$

$$\text{When } f'_c = 4000 \text{ psi (30 MPa), } n = 8.$$

$$\text{When } f'_c = 5000 \text{ psi (17.5 MPa), } n = 7.$$

For normal-weight concrete,  $n$  may be taken as  $500/\sqrt{f'_c}$  (psi units).

### 6.2.3 Cracking Moment

The behavior of a simply supported structural concrete beam loaded to failure was explained in Section 3.3. At a low load, a small bending moment develops, and the stress at the extreme tension fibers will be less than the modulus of rupture of concrete,  $f_r = 7.5\lambda\sqrt{f'_c}$ . If the load is increased until the tensile stress reaches an average stress of the modulus of rupture,  $f_r$ , cracks will develop. If the tensile stress is higher than  $f_r$ , the section will crack, and a cracked section case will develop. This means that there are three cases to be considered:

1. When the tensile stress,  $f_t$ , is less than  $f_r$ , the whole-uncracked section is considered to calculate the properties of the section. In this case, the gross moment of inertia,  $I_g$ , is used:  $I_g = bh^3/12$ , where  $bh$  is the whole concrete section.
2. When the tensile stress,  $f_t$ , is equal to the modulus of rupture,  $f_r = 7.5\lambda\sqrt{f'_c}$ , a crack may start to develop, and the moment that causes this stress is called the cracking moment. Using the flexural formula,

$$f_r = M_{\text{cr}} \frac{c}{I_g} \quad \text{or} \quad M_{\text{cr}} = f_r \frac{I_g}{c} \quad (6.4)$$



where  $f_r = 7.5\lambda\sqrt{f'_c}$ ,  $I_g$  is the gross moment of inertia, and  $c$  is the distance from the neutral axis to the extreme tension fibers. For example, for a rectangular section,  $I_g = bh^3/12$  and  $c = h/2$ , and  $\lambda$  is a modification factor for type of concrete (ACI Table 19.2.4.2) given as

$$\lambda = \begin{cases} 1.0 & \text{for normal-weight concrete} \\ 0.85 & \text{for sand-lightweight concrete} \\ 0.75 & \text{for all-lightweight concrete} \end{cases}$$

Linear interpolation shall be permitted between 0.85 and 1.0 on the basis of volumetric fractions, for concrete containing normal-weight fine aggregate and a blend of lightweight and normal-weight coarse aggregate.

- When the applied external moment exceeds the cracking moment,  $M_{cr}$ , a cracked section case is developed, and the concrete in the tension zone is neglected. A transformed cracked section is used to calculate the cracking moment of inertia,  $I_{cr}$ , using the concrete area in compression and the transformed steel area  $nA_s$ .

### Example 6.1

A rectangular concrete section is reinforced with three no. 9 bars in one row and has a width of 12 in., a total depth of 25 in., and  $d = 22.5$  (Fig. 6.1). Calculate the modulus of rupture,  $f_r$ , the gross moment of inertia,  $I_g$ , and the cracking moment,  $M_{cr}$ . Use  $f'_c = 4$  ksi and  $f_y = 60$  ksi.

#### Solution

- The modulus of rupture is

$$f_r = 7.5\lambda\sqrt{f'_c} = 7.5 \times 1 \times \sqrt{4000} = 474 \text{ psi} \quad (\lambda = 1 \text{ normal - weight concrete})$$

- The gross moment of inertia for a rectangular section is

$$\frac{bh^3}{12} = \frac{12(25)^3}{12} = 15,625 \text{ in.}^4$$

- The cracking moment is  $M_{cr} = f_r I_g / c$ ,

$$f_r = 474 \text{ psi} \quad I_g = 15,625 \text{ in.}^4 \quad c = \frac{1}{2}h = 12.5 \text{ in.}$$

$$\text{Therefore, } M_{cr} = 474 \times 15,625 / (12.5 \times 1000) = 592.5 \text{ K} \cdot \text{in.} = 49.38 \text{ K} \cdot \text{ft.}$$

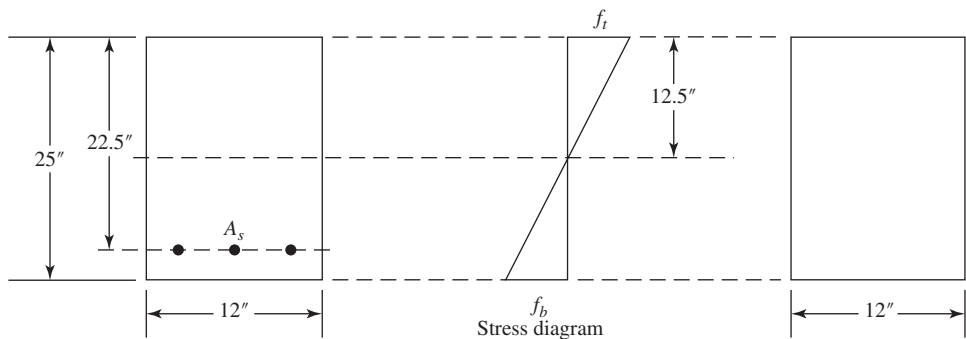


Figure 6.1 Example 6.1.

### 6.2.4 Moment of Inertia

The moment of inertia, in addition to the modulus of elasticity, determines the stiffness of the flexural member. Under small loads, the produced maximum moment will be small, and the tension stresses at the extreme tension fibers will be less than the modulus of rupture of concrete; in this case, the gross transformed cracked section will be effective in providing the rigidity. At working loads or higher, flexural tension cracks are formed. At the cracked section, the position of the neutral axis is high, whereas at sections midway between cracks along the beam, the position of the neutral axis is lower (nearer to the tension steel). In both locations only the transformed cracked sections are effective in determining the stiffness of the member; therefore, the effective moment of inertia varies considerably along the span. At maximum bending moment, the concrete is cracked, and its portion in the tension zone is neglected in the calculations of moment of inertia. Near the points of inflection the stresses are low, and the entire section may be uncracked. For this situation and in the case of beams with variable depth, exact solutions are complicated.

Figure 6.2*a* shows the load–deflection curve of a concrete beam tested to failure. The beam is a simply supported 17-ft span and loaded by two concentrated loads 5 ft apart, symmetrical about the centerline. The beam was subjected to two cycles of loading: In the first (curve *cy 1*), the load–deflection curve was a straight line up to a load  $P = 1.7$  K when cracks started to occur in the beam. Line *a* represents the load–deflection relationship using a moment of inertia for the uncracked transformed section. It can be seen that the actual deflection of the beam under loads less than the cracking load, based on a homogeneous uncracked section, is very close to the calculated deflection (line *a*). Curve *cy 1* represents the actual deflection curve when the load is increased to about one-half the maximum load. The slope of the curve, at any level of load, is less than the slope of line *a* because cracks developed, and the cracked part of the concrete section reduces the stiffness of the beam. The load was then released, and a residual deflection was observed at midspan. Once cracks developed, the assumption of uncracked section behavior under small loads did not hold.

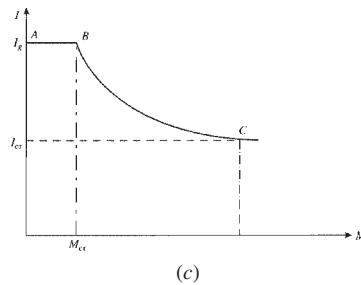
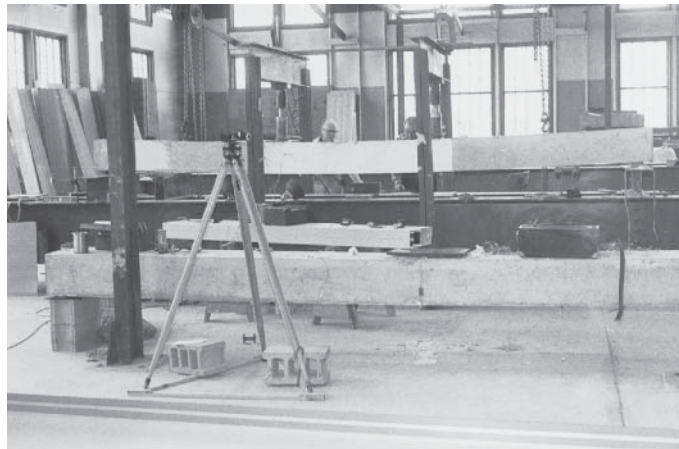
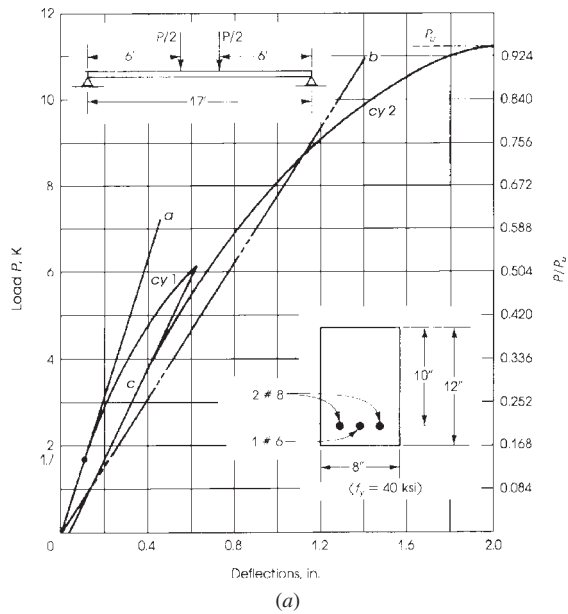
In the second cycle of loading, the deflection (curve *c*) increased at a rate greater than that of line *a*, because the resistance of the concrete tension fibers was lost. When the load was increased, the load–deflection relationship was represented by curve *cy 2*. If the load in the first cycle is increased up to the maximum load, curve *cy 1* will take the path *cy 2* at about 0.6 of the maximum load. Curve *c* represents the actual behavior of the beam for any additional loading or unloading cycles.

Line *b* represents the load–deflection relationship based on a cracked transformed section; it can be seen that the deflection calculated on that basis differs from the actual deflection. Figure 6.2*c* shows the variation of the beam stiffness  $EI$  with an increase in moment. ACI Code, Section 24.2.3.5, presents an equation to determine the effective moment of inertia used in calculating deflection in flexural members. The effective moment of inertia given by the ACI Code (Eq. 24.2.3.5a) is based on the expression proposed by Branson [3] and calculated as follows:

$$I_e = \left( \frac{M_{cr}}{M_a} \right)^3 I_g + \left[ 1 - \left( \frac{M_{cr}}{M_a} \right)^3 \right] I_{cr} \leq I_g \quad (6.5)$$

where  $I_e$  is the effective moment of inertia, the cracking moment is given as

$$M_{cr} = \left( \frac{f_r I_g}{Y_t} \right) \quad (6.6)$$



**Figure 6.2** (a) Experimental and theoretical load–deflection curves for a beam of the section and load illustrated, (b) deflection of a reinforced concrete beam, and (c) variation of beam moment of inertia,  $I$ , with an increase in moment ( $E = \text{const}$ ).  $BC$  is a transition curve between  $I_g$  and  $I_{cr}$ .

and the modulus of rupture of concrete as

$$f_r = 7.5\lambda\sqrt{f'_c}\text{psi} \quad (0.623\lambda\sqrt{f'_c}\text{MPa}) \quad (6.7)$$

and

- $M_a$  = maximum unfactored moment in member at stage for which deflection is being computed
- $I_g$  = moment of inertia of gross concrete section about centroidal axis, neglecting reinforcement
- $I_{cr}$  = moment of inertia of cracked transformed section
- $Y_t$  = distance from centroidal axis of cross section, neglecting steel, to tension face

The following limitations are specified by the code:

1. For continuous spans, the effective moment of inertia may be taken as the average of the moment of inertia of the critical positive- and negative-moment sections.
2. For prismatic members,  $I_e$  may be taken as the value obtained from Eq. 6.5 at midspan for simple and continuous spans and at the support section for cantilevers (ACI Code, Section 24.2.3.6 and 24.2.3.7).

Note that  $I_e$ , as computed by Eq. 6.5, provides a transition between the upper and lower bounds of the gross moment of inertia,  $I_g$ , and the cracked moment of inertia,  $I_{cr}$ , as a function of the level of  $M_{cr}/M_a$ . Heavily reinforced concrete members may have an effective moment of inertia,  $I_e$ , very close to that of a cracked section,  $I_{cr}$ , whereas flanged members may have an effective moment of inertia close to the gross moment of inertia,  $I_g$ .

3. For continuous beams, an approximate value of the average  $I_e$  for prismatic or nonprismatic members for somewhat improved results is as follows: For beams with both ends continuous,

$$\text{Average } I_e = 0.70I_m + 0.15(I_{e1} + I_{e2}) \quad (6.8)$$

For beams with one end continuous,

$$\text{Average } I_e = 0.85I_m + 0.15(I_{con}) \quad (6.9)$$

where  $I_m$  is the midspan  $I_e$ ,  $I_{e1}$ ,  $I_{e2} = I_e$  at beam ends, and  $I_{con} = I_e$  at the continuous end. Also,  $I_e$  may be taken as the average value of the  $I_e$ 's at the critical positive- and negative-moment sections. Moment envelopes should be used in computing both positive and negative values of  $I_e$ . In the case of a beam subjected to a single heavy concentrated load, only the midspan  $I_e$  should be used.

### 6.2.5 Properties of Sections

To determine the moment of inertia of the gross and cracked sections, it is necessary to calculate the distance from the compression fibers to the neutral axis ( $x$  or  $kd$ ).

1. Gross moment of inertia,  $I_g$  (neglect all steel in the section):
  - a. For a rectangular section of width  $b$  and a total depth  $h$ ,  $I_g = bh^3/12$ .
  - b. For a T-section, flange width  $b$ , web width  $b_w$ , and flange thickness  $t$ , calculate  $y$ , the distance to the centroidal axis from the top of the flange:

$$y = \frac{(bt^2/2) + b_w(h-t)[(h+t)/2]}{bt + b_w(h-t)} \quad (6.10)$$

Then calculate  $I_g$ :

$$I_g = \left[ \frac{bt^3}{12} + bt \left( y - \frac{t}{2} \right)^2 \right] + \left[ b_w \frac{(y-t)^3}{3} \right] + \left[ b_w \frac{(h-y)^3}{3} \right]$$

2. Cracked moment of inertia,  $I_{cr}$ : Let  $x$  be the distance of the neutral axis from the extreme compression fibers ( $x = kd$ ).

a. Rectangular section with tension steel,  $A_s$ , only:

i. Calculate  $x$  from the equation

$$\frac{bx^2}{2} - nA_s(d-x) = 0 \quad (6.11)$$

ii. Calculate

$$I_{cr} = \frac{bx^3}{3} + nA_s(d-x)^2 \quad (6.11a)$$

b. Rectangular section with tension steel  $A_s$  and compression steel  $A'_s$ :

i. Calculate  $x$ :

$$x = \frac{bx^2}{2} + (n-1)A'_s(x-d') - nA_s(d-x) = 0 \quad (6.12)$$

ii. Calculate

$$I_{cr} = \frac{bx^3}{3} + (n-1)A'_s(x-d')^2 + nA_s(d-x)^2 \quad (6.12a)$$

c. T-sections with tension steel  $A_s$ :

i. Calculate  $x$ :

$$x = bt \left( x - \frac{t}{2} \right) + b_w \frac{(x-t)^2}{2} - nA_s(d-x) = 0 \quad (6.13)$$

ii. Calculate  $I_{cr}$ :

$$I_{cr} = \left[ \frac{bt^3}{12} + bt \left( x - \frac{t}{2} \right)^2 \right] + \left[ b_w \frac{(x-t)^3}{3} \right] + nA_s(d-x)^2 \quad (6.13a)$$

## 6.3 LONG-TIME DEFLECTION

Deflection of reinforced concrete members continues to increase under sustained load, although more slowly with time. Shrinkage and creep are the cause of this additional deflection, which is called long-time deflection [1]. It is influenced mainly by temperature, humidity, age at time of loading, curing, quantity of compression reinforcement, and magnitude of the sustained load. The ACI Code, Section 24.2.4.1, suggests that unless values are obtained by a more comprehensive analysis, the additional long-term deflection for both normal and lightweight concrete flexural members shall be obtained by multiplying the immediate deflection caused by sustained load by the factor

$$\lambda_{\Delta} = \frac{\zeta}{1 + 50\rho'} \quad (6.14)$$

where

$\lambda_{\Delta}$  = multiplier for additional deflection due to long-term effect.

$\rho'$  =  $A'_s/bd$  for section at midspan of simply supported or continuous beam or at support of cantilever beam

$\zeta$  = time-dependent factor for sustained loads that may be taken as shown in Table 6.2.

**Table 6.2** Multipliers for Long-Time Deflections

Period (months)	1	3	6	12	24	36	48	60 and over
$\zeta$	0.5	1.0	1.2	1.4	1.7	1.8	1.9	2.0

The factor  $\lambda_{\Delta}$  is used to compute deflection caused by the dead load and the portion of the live load that will be sustained for a sufficient period to cause significant time-dependent deflections. The factor  $\lambda_{\Delta}$  is a function of the material property, represented by  $\zeta$ , and the section property, represented by  $1 + 50\rho'$ . In Eq. 6.14, the effect of compression reinforcement is related to the area of concrete rather than the ratio of compression to tension steel.

The ACI Code Commentary, Section 24.2.4.1.3, presents a curve to estimate  $\zeta$  for periods less than 60 months. These values are estimated as shown in Table 6.2.

The total deflection is equal to the immediate deflection plus the additional long-time deflection. For instance, the total additional long-time deflection of a flexural beam with  $\rho' = 0.01$  at a 5-year period is equal to  $\lambda_{\Delta}$  times the immediate deflection, where  $\lambda_{\Delta} = 2/(1 + 50 \times 0.01) = 1.33$ .

## 6.4 ALLOWABLE DEFLECTION

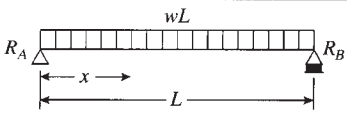
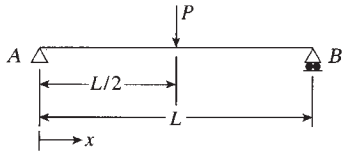
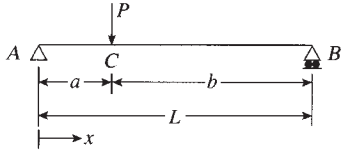
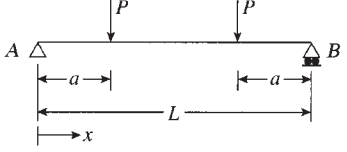
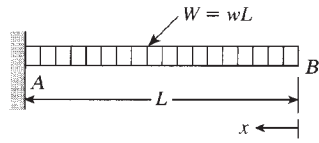
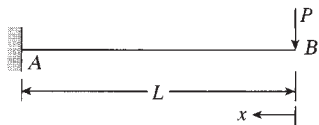
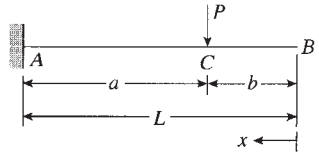
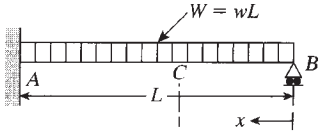
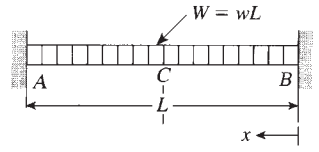
Deflection shall not exceed the following values according to the ACI Code, Section 24.2.2:

- $L/180$  for immediate deflection due to service roof live load, snow loads, and rain loads for flat roofs not supporting elements that are likely to be damaged by large deflections.
- $L/360$  for immediate deflection due to live load for floors not supporting elements likely to be damaged by large deflections.
- $L/480$  for the part of the total deflection that occurs after attachment of elements, that is, the sum of the long-time deflection due to all sustained loads and the immediate deflection due to any additional live load, for floors or roofs supporting elements likely to be damaged by large deflections.
- $L/240$  for the part of the total deflection occurring after elements are attached, for floors or roofs not supporting elements not likely to be damaged by large deflections.

## 6.5 DEFLECTION DUE TO COMBINATIONS OF LOADS

If a beam is subjected to different types of loads (uniform, nonuniform, or concentrated loads) or subjected to end moments, the deflection may be calculated for each type of loading or force applied on the beam separately and the total deflection calculated by superposition. This means that all separate deflections are added up algebraically to get the total deflection. The deflections of beams under individual loads are shown in Table 6.3.

**Table 6.3** Deflection of Beams

$\Delta_{\max} = \frac{5}{384} \times \frac{WL^3}{EI} \quad (\text{at center})$ $W = \text{total load} = wL$	
$\Delta_{\max} = \frac{PL^3}{48EI} \quad (\text{at midspan})$	
$\Delta_C = \frac{Pa^2b^2}{3EIL} \quad (\text{at point load})$ $\Delta_{\max} = \frac{PL^3}{48EI} \left[ \frac{3a}{L} - 4\left(\frac{a}{L}\right)^3 \right] \quad (\text{when } a \geq b)$ $\text{at } x = \sqrt{a(b+L)/3}$	
$\Delta_{\max} = \frac{PL^3}{6EI} \left[ \frac{3a}{4L} - \left(\frac{a}{L}\right)^3 \right] \quad (\text{at midspan})$ $\Delta_{\max} = \frac{23PL^3}{648EI} \quad (\text{at midspan when } a = L/3)$	
$\Delta_B \max = \frac{WL^3}{8EI} \quad (W = wL)$ $\Delta_x = \frac{w}{24EI} (x^4 - 4L^3x + 3L^4)$	
$\Delta_B \max = \frac{PL^3}{3EI}$ $\Delta_x = \frac{P}{6EI} (2L^3 - 3L^2x + x^3)$	
$\Delta_C = \frac{Pa^3}{3EI}$ $\Delta_B \max = \frac{Pa^3}{3EI} \left( 1 + \frac{3b}{2a} \right) \quad (\text{at free end})$	
$\Delta_{\max} = \frac{WL^3}{185EI}$ <p>at a distance <math>x = 0.4215L</math> (from support B)</p>	
$\Delta_{\max} = \frac{WL^3}{384EI} \quad (\text{at midspan})$	

**Example 6.2**

Calculate the instantaneous midspan deflection for the simply supported beam shown in Fig. 6.3, which carries a uniform dead load of 0.4 K/ft and a live load of 0.6 K/ft in addition to a concentrated dead load of 5 kips at midspan. Given:  $f'_c = 4$  ksi normal-weight concrete,  $f_y = 60$  ksi,  $b = 13$  in.,  $d = 21$  in., and total depth = 25 in. ( $n = 8$ ).

**Solution**

1. Check minimum depth according to Table 6.1:

$$\text{Minimum total depth} = \frac{L}{16} = \frac{40 \times 12}{16} = 30 \text{ in.}$$

The total thickness used is 25 in. < 30 in.; therefore, deflection must be checked.

2. The deflection at midspan due to a distributed load is

$$\Delta_1 = \frac{5wL^4}{384E_cI_e}$$

The deflection at midspan due to a concentrated load is

$$\Delta_2 = \frac{PL^3}{48E_cI_e}$$

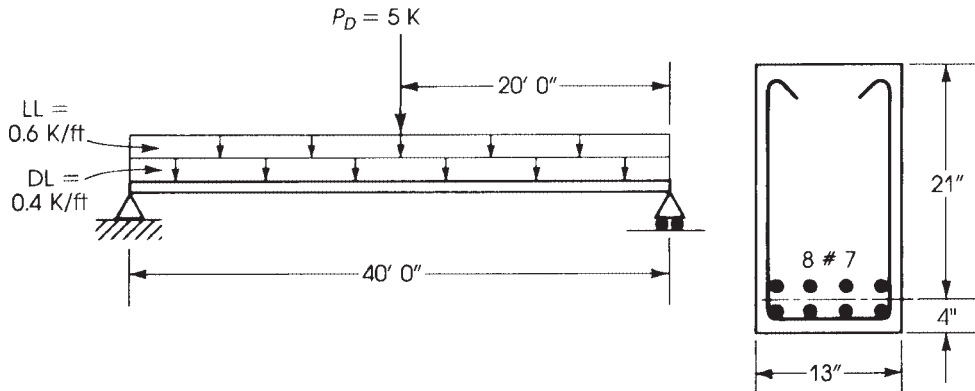
Because  $w$ ,  $P$ , and  $L$  are known, we must determine the modulus of elasticity,  $E_c$ , and the effective moment of inertia,  $I_e$ .

3. The modulus of elasticity of concrete is

$$E_c = 57,000\sqrt{f'_c} = 57,000\sqrt{4000} = 3.60 \times 10^6 \text{ psi}$$

4. The effective moment of inertia is equal to:

$$I_e = \left(\frac{M_{cr}}{M_a}\right)^3 I_g + \left[1 - \left(\frac{M_{cr}}{M_a}\right)^3\right] I_{cr} \leq I_g$$



**Figure 6.3** Example 6.2.



Determine values of all terms on the right-hand side:

$$M_a = \frac{wL^2}{8} + \frac{PL}{4} = \frac{0.6 + 0.4}{8}(40)^2 \times 12 + \frac{5 \times 40}{4} \times 12 = 3000 \text{ K} \cdot \text{in.}$$

$$I_g = \frac{bh^3}{12} = \frac{13(25)^3}{12} = 16,927 \text{ in.}^4$$

$$M_{cr} = \frac{f_r I_g}{Y_t} \quad Y_t = \frac{h}{2} = 12.5 \text{ in.} \quad f_r = 7.5\lambda \sqrt{f'_c} = 474 \text{ psi} \quad \lambda = 1 \quad (\text{normal weight})$$

$$M_{cr} = \frac{0.474 \times 16,927}{12.5} = 642 \text{ K} \cdot \text{in.}$$

The moment of inertia of the cracked transformed area,  $I_{cr}$ , is calculated as follows: Determine the position of the neutral axis for a cracked section by equating the moments of the transformed area about the neutral axis to 0, letting  $x = kd =$  distance to the neutral axis:

$$\frac{bx^2}{2} - nA_s(d-x) = 0 \quad n = \frac{E_s}{E_c} = 8.0 \quad A_s = 4.8 \text{ in.}^2$$

$$\frac{13}{2}x^2 - (8)(4.8)(21-x) = 0$$

$$x^2 + 5.9x - 124 = 0 \quad x = 8.8 \text{ in.}$$

$$I_{cr} = \frac{bx^3}{3} + nA_s(d-x)^2 = \frac{13(8.8)^3}{3} + 38.4(21-8.8)^2 = 8660 \text{ in.}^4$$

With all terms calculated,

$$I_e = \left(\frac{642}{3000}\right)^3 \times 16,927 + \left[1 - \left(\frac{642}{3000}\right)^3\right] \times 8660 = 8740 \text{ in.}^4$$

5. Calculate the deflections from the different loads:

$$A_1 = \frac{5wL^4}{384E_c I_e} \quad (\text{due to distributed load})$$

$$= \left(\frac{5}{384}\right) \times \left(\frac{1000}{12}\right) \times \frac{(40 \times 12)^4}{3.60 \times 10^6 \times 8740} = 1.83 \text{ in.}$$

$$A_2 = \frac{PL^3}{48E_c I_e} \quad (\text{due to concentrated load})$$

$$= \frac{5000 \times (40 \times 12)^3}{48 \times 3.60 \times 10^6 \times 8740} = 0.36 \text{ in.}$$

and

$$\text{Total immediate deflection} = A_1 + A_2 = 1.83 + 0.36 = 2.19 \text{ in.}$$

6. Compare the calculated values with the allowable deflection: The immediate deflection due to a uniform live load of 0.6 K/ft is equal to  $0.6(1.83) = 1.10$  in. If the member is part of a floor construction not supporting or attached to partitions or other elements likely to be damaged by large deflection, the allowable immediate deflection due to live load is equal to

$$\frac{L}{360} = \frac{40 \times 12}{360} = 1.33 \text{ in.} > 1.10 \text{ in.}$$

If the member is part of a flat roof and similar to the preceding, the allowable immediate deflection due to live load is  $L/180 = 2.67$  in. Both allowable values are greater than the actual deflection of 1.10 in. due to the uniform applied live load.

**Example 6.3**

Determine the long-time deflection of the beam in Example 6.2 if the time-dependent factor equals 2.0.

**Solution**

1. The sustained load causing long-time deflection is that due to dead load, consisting of a distributed uniform dead load of 0.4 K/ft and a concentrated dead load of 5 K at midspan:

$$\text{Deflection due to uniform load} = 0.4 \times 1.83 = 0.73 \text{ in.}$$

Deflection is a linear function of load,  $w$ , all other values ( $L, E_c, I_e$ ) being the same:

$$\text{Deflection due to concentrated load} = 0.36 \text{ in.}$$

$$\begin{aligned} \text{Total immediate deflection due to sustained loads} &= 0.73 + 0.36 \\ &= 1.09 \text{ in.} \end{aligned}$$

2. For additional long-time deflection, the immediate deflection is multiplied by the factor  $\lambda_\Delta$ :

$$\lambda_\Delta = \frac{\zeta}{1 + 50\rho'} = \frac{2}{1 + 0}$$

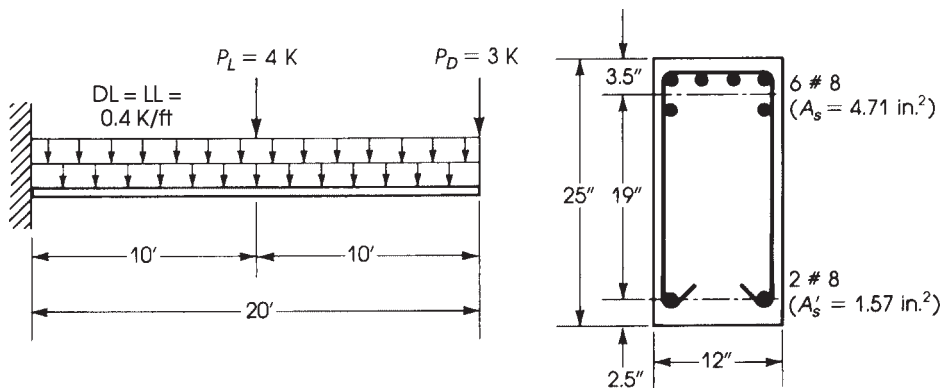
In this problem,  $A'_s = 0$ ; therefore,  $\lambda_\Delta = 2.0$ .

$$\text{Additional long-time deflection} = 2 \times 1.09 = 2.18 \text{ in.}$$

3. Total long-time deflection is the immediate deflection plus additional long-time deflection:  $2.19 + 2.18 = 4.37$  in.
4. Deflection due to dead load plus additional long-time deflection due to shrinkage and creep is  $1.09 + 2.18 = 3.27$  in.

**Example 6.4**

Calculate the instantaneous and 1-year long-time deflection at the free end of the cantilever beam shown in Fig. 6.4. The beam has a 20-ft span and carries a uniform dead load of 0.4 K/ft, a uniform live load of 0.4 K/ft, a concentrated dead load,  $P_D$ , of 3 K at the free end, and a concentrated live load,  $P_L$ , of 4 K



**Figure 6.4** Example 6.4.

placed at 10 ft from the fixed end. Given:  $f'_c = 4$  ksi,  $f_y = 60$  ksi,  $b = 12$  in.,  $d = 21.5$  in., and total depth of section = 25 in. (Tension steel is six no. 8 bars and compression steel is two no. 8 bars.) Assume normal-weight concrete.

### Solution

- Minimum depth =  $L/8 = \frac{20}{8} = 2.5$  ft = 30 in., which is greater than the 25 in. used. Therefore, deflection must be checked. The maximum deflection of a cantilever beam is at the free end. The deflection at the free end is as follows.

- Deflection due to distributed load:

$$\Delta_1 = \frac{wL^4}{8EI}$$

- Deflection due to a concentrated dead load at the free end:

$$\Delta_2 = \frac{P_D L^3}{3EI}$$

- Deflection due to concentrated live load at  $a = 10$  ft from the fixed end is maximum at the free end:

$$\Delta_3 = \frac{P_L(a)^2}{6EI}(3L - a) \quad \text{or} \quad \Delta_3 = \frac{Pa^3}{3EI} \left(1 + \frac{3b}{2a}\right)$$

- The modulus of elasticity of normal-weight concrete is

$$E_c = 57,000\sqrt{f'_c} = 57,000\sqrt{4000} = 3.60 \times 10^6 \text{ psi}$$

- Maximum moment at the fixed end is

$$\begin{aligned} M_a &= \frac{wL^2}{2} + P_D \times 20 + P_L \times 10 \\ &= \frac{1}{2}(0.4 + 0.4)(400) + 3 \times 20 + 4 \times 10 = 260 \text{ K} \cdot \text{ft} \end{aligned}$$

- $I_g$  = gross moment of inertia (concrete only)

$$= \frac{bh^3}{12} = \frac{12 \times (25)^3}{12} = 15,625 \text{ in.}^4$$

- 

$$M_{cr} = \frac{f_r I_g}{Y_t} = \frac{(7.5)(1)\sqrt{4000} \times 15,625}{25/2} = 592.9 \text{ K} \cdot \text{in.} = 49.40 \text{ K} \cdot \text{ft}$$

- Determine the position of the neutral axis; then determine the moment of inertia of the cracked transformed section. Take moments of areas about the neutral axis and equate them to zero. Use  $n = 8$  to calculate the transformed area of  $A_s$  and use  $n-1 = 7$  to calculate the transformed area of  $A'_s$ . Let  $kd = x$ :

$$b \frac{x^2}{2} + (n-1)A'_s(x-d') - nA_s(d-x) = 0$$

For this section,  $x = 8.44$  in.:

$$I_{cr} = \frac{b}{3}x^3 + (n-1)A'_s(x-d')^2 + nA_s(d-x)^2 = 9220 \text{ in.}^4$$

- Effective moment of inertia is

$$\begin{aligned} I_e &= \left(\frac{M_{cr}}{M_a}\right)^3 I_g + \left[1 - \left(\frac{M_{cr}}{M_a}\right)^3\right] I_{cr} \leq I_g \\ &= \left(\frac{49.40}{260}\right)^3 \times 15,625 + \left[1 - \left(\frac{49.40}{260}\right)^3\right] \times 9220 = 9264 \text{ in.}^4 \end{aligned}$$

8. Determine the components of the deflection:

$$\Delta_1 = \frac{800}{12} \times \frac{(20 \times 12)^4}{8 \times 3.60 \times 10^6 \times 9264} = 0.82 \text{ in.} \quad (\text{due to uniform load of } 0.8 \text{ K/ft})$$

$$= 0.82 \times \frac{0.4}{0.8} = 0.41 \text{ in.} \quad (\text{due to dead load})$$

$$\Delta_2 = \frac{3000(20 \times 12)^3}{3 \times 3.60 \times 10^6 \times 9264} = 0.41 \text{ in.} \quad (\text{due to concentrated dead load at free end})$$

$$\Delta_3 = \frac{4000(10 \times 12)^2 \times (3 \times 20 \times 12 - 10 \times 12)}{6 \times 3.60 \times 10^6 \times 9264} = 0.17 \text{ in.} \quad (\text{due to concentrated live load at } 10 \text{ ft from fixed end})$$

The total immediate deflection is

$$\Delta_s = \Delta_1 + \Delta_2 + \Delta_3 = 0.82 + 0.41 + 0.17 = 1.40 \text{ in.}$$

9. For additional long-time deflection, the immediated deflection is multiplied by the factor  $\lambda_A$ . For a 1-year period,  $\zeta = 1.4$ :

$$\rho' = \frac{A'_s}{bd} = \frac{1.57}{12 \times 21.5} = 0.0061$$

$$\lambda_A = \frac{1.4}{1 + 50 \times 0.0061} = 1.073$$

Total immediate deflection  $\Delta_s$  due to sustained load (here only the dead load of 0.4 K/ft and  $P_D = 3 \text{ K}$  at free end):  $\Delta_s = (\Delta_1 + \Delta_2) = (0.41 + 0.41) = 0.82 \text{ in.}$  Additional long-time deflection =  $1.073 \times 0.82 = 0.88 \text{ in.}$

10. Total long-time deflection is the immediate deflection plus long-time deflection due to shrinkage and creep:

$$\text{Total } \Delta = 1.40 + 0.88 = 2.28 \text{ in.}$$

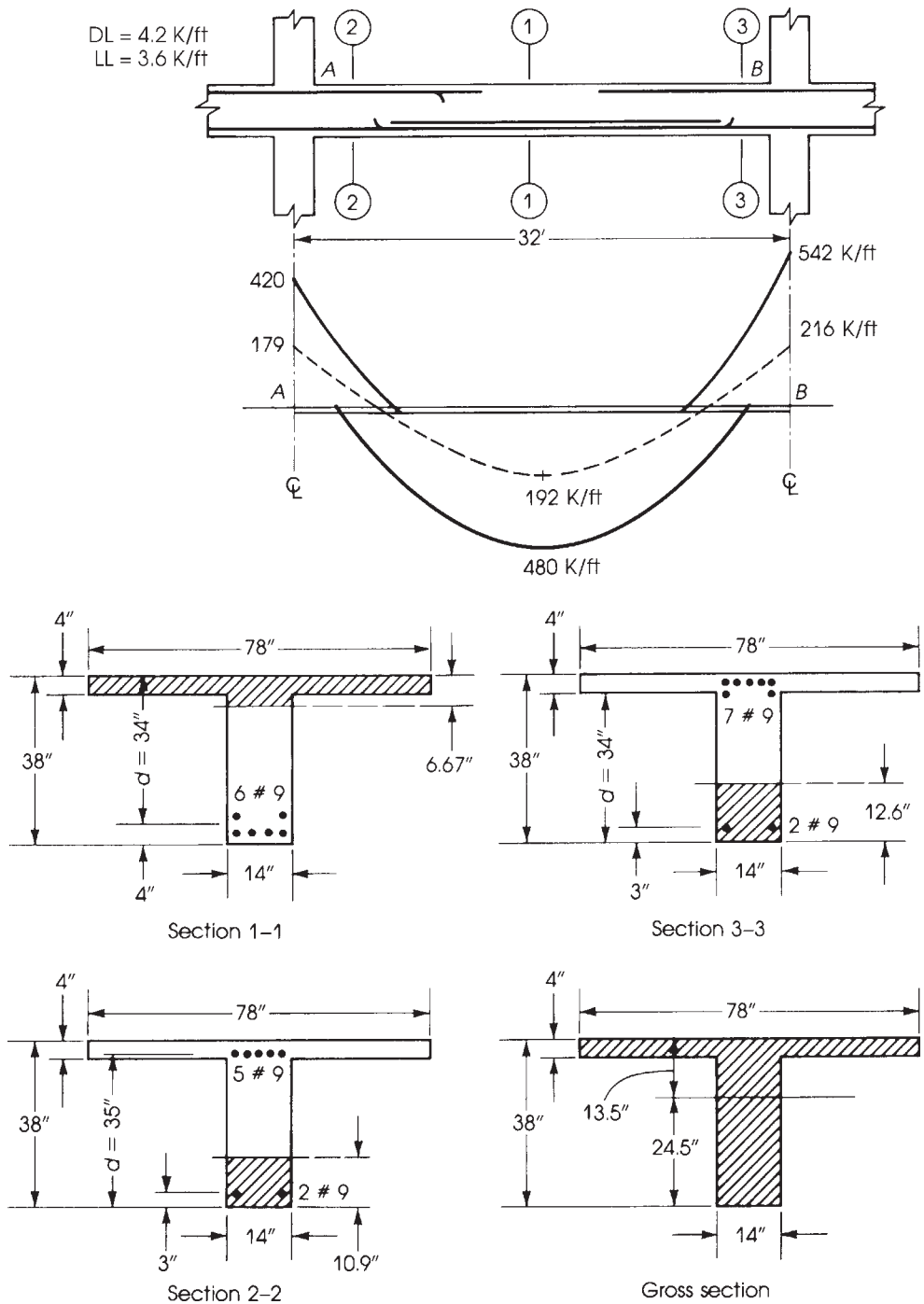
### Example 6.5

Calculate the instantaneous midspan deflection of beam  $AB$  in Fig. 6.5, which has a span of 32 ft. The beam is continuous over several supports of different span lengths. The absolute bending moment diagram and cross sections of the beam at midspan and supports are also shown. The beam carries a uniform dead load of 4.2 K/ft and a live load of 3.6 K/ft. Given:  $f'_c = 3 \text{ ksi}$  normal-weight concrete,  $f_y = 60 \text{ ksi}$ , and  $n = 9.2$ .

$$\text{Moment at midspan:} \quad M_D = 192 \text{ K} \cdot \text{ft} \quad M_{(D+L)} = 480 \text{ K} \cdot \text{ft}$$

$$\text{Moment at left support } A : \quad M_D = 179 \text{ K} \cdot \text{ft} \quad M_{(D+L)} = 420 \text{ K} \cdot \text{ft}$$

$$\text{Moment at right support } B : \quad M_D = 216 \text{ K} \cdot \text{ft} \quad M_{(D+L)} = 542 \text{ K} \cdot \text{ft}$$



**Figure 6.5** Example 6.5: deflection of continuous beam.

**Solution**

- The beam  $AB$  is subjected to a positive moment that causes a deflection downward at midspan and negative moments at the two ends, causing a deflection upward at midspan. As was explained earlier, the deflection is a function of the effective moment of inertia,  $I_e$ . In a continuous beam, the value of  $I_e$  to be used is the average value for the positive- and negative-moment regions. Therefore, three sections will be considered: the section at midspan and the sections at the two supports.
- Calculate  $I_e$ : For the gross area of all sections,  $kd = 13.5$  in. and  $I_g = 114,300$  in.<sup>4</sup> Also,  $f_r = 7.5\lambda\sqrt{f'_c} = 410$  psi and  $E_e = 57,000\sqrt{f'_c} = 3.12 \times 10^6$  for all sections. The values of  $kd$ ,  $I_{cr}$ , and  $M_{cr}$  for each cracked section,  $I_e$  for dead load only (using  $M_a$  of dead load), and  $I_e$  for dead and live loads (using  $M_a$  for dead and live loads) are calculated and tabulated as follows:

Section	$kd$ (in.)	$I_{cr}$ (in. <sup>4</sup> )	$y_t$	$M_{cr}$ (K·ft)	$I_e$ (in. <sup>4</sup> ) (Dead Load)	$I_e$ (in. <sup>4</sup> ) (D + L)
Midspan	6.67	48,550	24.5	159.4	86,160	50,960
Support A	10.9	34,930	13.5	289.3	114,300	60,880
Support B	12.6	44,860	13.5	289.3	114,300	55,415

Note that when the beam is subjected to dead load only and the ratio  $M_{cr}/M_a$  is greater than 1.0,  $I_e = I_g$ .

- Calculate average  $I_e$  from Eq. 6.8:

$$\begin{aligned} I_{e1}(\text{average}) &= 0.7(50,960) + 0.15(60,880 + 55,415) \\ &= 53,116 \text{ in.}^4 \end{aligned}$$

For dead and live loads,

$$\begin{aligned} \text{Average } I_e \text{ for end sections} &= \frac{1}{2}(60,880 + 55,415) \\ &= 58,150 \text{ in.}^4 \end{aligned}$$

$$I_{e2}(\text{average}) = \frac{1}{2}(50,960 + 58,150) = 54,550 \text{ in.}^4$$

For dead loads only,

$$\text{Average } I_e \text{ for end sections} = 114,300 \text{ in.}^4$$

$$I_{e3}(\text{average}) = \frac{1}{2}(86,160 + 114,300) = 100,230 \text{ in.}^4$$

- Calculate immediate deflection at midspan:

$$\Delta_1(\text{due to uniform load}) = \frac{5wL^4}{384EI_e} \quad (\text{downward})$$

$$\Delta_2(\text{due to a moment at A, } M_A) = \frac{M_A L^2}{16EI_e} \quad (\text{upward})$$

$$\Delta_3(\text{due to a moment at B, } M_B) = -\frac{M_B L^2}{16EI_e} \quad (\text{upward})$$

$$\text{Total deflection } \Delta = \Delta_1 - \Delta_2 - \Delta_3$$

The dead-load deflection for a uniform dead load of 4.2 K/ft, taking  $M_A$  (dead load) = 179 K·ft,  $M_B$  (dead load) = 216 K·ft, and  $I_{e3} = 100,230 \text{ in.}^4$  and then substituting in the preceding equations, is

$$\Delta = 0.314 - 0.063 - 0.075 = 0.176 \text{ in. (downward)}$$

The deflection due to combined dead and live loads is found by taking dead plus live load = 7.8 K/ft,  $M_A = 420 \text{ K} \cdot \text{ft}$ ,  $M_B = 542 \text{ K} \cdot \text{ft}$ , and  $I_{e2} = 54,550 \text{ in.}^4$ :

$$\Delta = 1.071 - 0.270 - 0.349 = 0.452 \text{ in. (downward)}$$

The immediate deflection due to live load only is  $0.452 - 0.176 = 0.276 \text{ in. (downward)}$ . If the limiting permissible deflection is  $L/480 = (32 \times 12)/480 = 0.8 \text{ in.}$ , then the section is adequate.

There are a few points to mention about the results:

- a. If  $I_e$  of the midspan section only is used ( $I_e = 50,960 \text{ in.}^4$ ), then the deflection due to dead plus live loads is calculated by multiplying the obtained value in step 4 by the ratio of the two  $I_e$ :

$$\Delta(\text{dead} + \text{live}) = 0.452 \times \left( \frac{54,550}{50,960} \right) = 0.484 \text{ in.}$$

The difference is small, about 7% on the conservative side.

- b. If  $I_{e1}$  (average) is used ( $I_{e1} = 53,116 \text{ in.}^4$ ), then  $\Delta$  (dead + live) = 0.471 in. The difference is small, about 4% on the conservative side.
- c. It is believed that it is more convenient to use  $I_e$  at the midspan section unless a more rigorous solution is required.

## 6.6 CRACKS IN FLEXURAL MEMBERS

The study of crack formation, behavior of cracks under increasing load, and control of cracking is necessary for proper design of reinforced concrete structures. In flexural members, cracks develop under working loads, and because concrete is weak in tension, reinforcement is placed in the cracked tension zone to resist the tension force produced by the external loads.

Flexural cracks develop when the stress at the extreme tension fibers exceeds the modulus of rupture of concrete. With the use of high-strength reinforcing bars, excessive cracking may develop in reinforced concrete members. The use of high-tensile-strength steel has many advantages, yet the development of undesirable cracks seems to be inevitable. Wide cracks may allow corrosion of the reinforcement or leakage of water structures and may spoil the appearance of the structure.

A crack is formed in concrete when a narrow opening of indefinite dimension has developed in the concrete beam as the result of internal tensile stresses. These internal stresses may be due to one or more of the following:

- External forces such as direct axial tension, shear, flexure, or torsion.
- Shrinkage.
- Creep.
- Internal expansion resulting from a change of properties of the concrete constituents.

In general, cracks may be divided into two main types: secondary cracks and main cracks.

### 6.6.1 Secondary Cracks

*Secondary cracks*, very small cracks that develop in the first stage of cracking, are produced by the internal expansion and contraction of the concrete constituents and by low flexural tension stresses

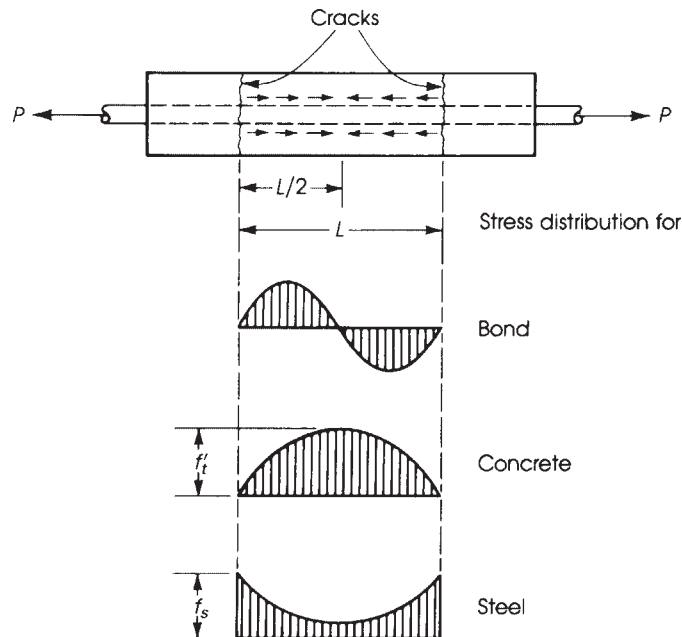
due to the self-weight of the member and any other dead loads. There are three types of secondary cracks: Shrinkage, flexural, and corrosion.

**Shrinkage Cracks.** *Shrinkage cracks* are important cracks, because they affect the pattern of cracking that is produced by loads in flexural members. When they develop, they form a weak path in the concrete. When load is applied, cracks start to appear at the weakest sections, such as along the reinforcing bars. The number of cracks formed is limited by the amount of shrinkage in concrete and the presence of restraints. Shrinkage cracks are difficult to control.

**Secondary Flexural Cracks.** Usually *secondary flexural cracks* are widely spaced, and one crack does not influence the formation of others [8]. They are expected to occur under low loads, such as dead loads. When a load is applied gradually on a simple beam, tensile stress develops at the bottom fibers, and when it exceeds the flexural tensile stress of concrete, cracks start to develop. They widen gradually and extend toward the neutral axis. It is difficult to predict the sections at which secondary cracks start because concrete is not a homogeneous, isotropic material.

Salinger [9] and Billing [10] estimated the steel stress just before cracking to be from about 6000 to 7000 psi (42 to 49 MPa). An initial crack width of the order of 0.001 in. (0.025 mm) is expected at the extreme concrete tensile fibers. Once cracks are formed, the tensile stress of concrete at the cracked section decreases to zero, and the steel bars take all the tensile force. At this moment, some slip occurs between the steel bars and the concrete due to the differential elongation of concrete and steel and extends to a section where the concrete and steel strains are equal. Figure 6.6 shows the typical stress distribution between cracks in a member under axial tension.

**Corrosion Secondary Cracks.** *Corrosion secondary cracks* form when moisture containing deleterious agents such as sodium chloride, carbon dioxide, and dissolved oxygen penetrates



**Figure 6.6** Typical stress distribution between cracks.



the concrete surface, corroding the steel reinforcement [11]. The oxide compounds formed by deterioration of steel bars occupy a larger volume than the steel and exert mechanical pressure that perpetuates extensive cracking [12, 13]. This type of cracking may be severe enough to result in eventual failure of the structure. The failure of a roof in Muskegan, Michigan, in 1955 due to the corrosion of steel bars was reported by Shermer [13]. The extensive cracking and spalling of concrete in the San Mateo–Hayward Bridge in California within 7 years was reported by Stratful [12]. Corrosion cracking may be forestalled by using proper construction methods and high-quality concrete. More details are discussed by Evans [14] and Mozer and others [15].

### 6.6.2 Main Cracks

*Main cracks* develop at a later stage than secondary cracks. They are caused by the difference in strains in steel and concrete at the section considered. The behavior of main cracks changes at two different stages. At low tensile stresses in steel bars, the number of cracks increases, whereas the widths of cracks remain small; as tensile stresses are increased, an equilibrium stage is reached. When stresses are further increased, the second stage of cracking develops, and crack widths increase without any significant increase in the number of cracks. Usually one or two cracks start to widen more than the others, forming critical cracks (Fig. 6.7).

Main cracks in beams and axially tensioned members have been studied by many investigators; prediction of the width of cracks and crack control were among the problems studied. These are discussed here, along with the requirements of the ACI Code.

**Crack Width.** *Crack width* and *crack spacing*, according to existing crack theories, depend on many factors, which include steel percentage, its distribution in the concrete section, steel flexural stress at service load, concrete cover, and properties of the concrete constituents. Different equations for predicting the width and spacing of cracks in reinforced concrete members were presented at the Symposium on Bond and Crack Formation in Reinforced Concrete in Stockholm, Sweden, in 1957. Chi and Kirstein [16] presented equations for the crack width and spacing as a function of an effective area of concrete around the steel bar: A concrete circular area of diameter equal to four times the diameter of the bar was used to calculate crack width. Other equations were presented over the next decade [17–23].

Gergely and Lutz [23] presented the following formula for the limiting crack width:

$$W = 0.076\beta f_s \sqrt[3]{Ad_c} \times 10^{-6}(\text{in.}) \quad (6.15)$$

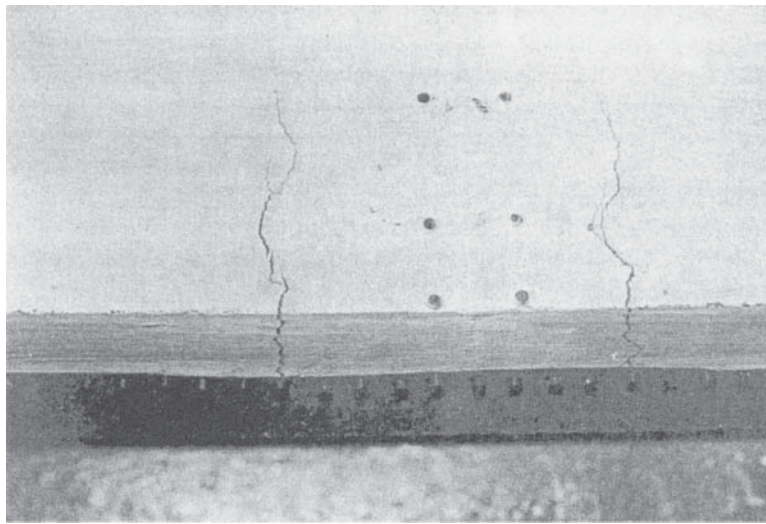
where  $\beta$ ,  $A$ , and  $f_s$  are as defined previously and  $d_c$  is the thickness of concrete cover measured from the extreme tension fiber to the center of the closest bar. The value of  $\beta$  can be taken to be approximately equal to 1.2 for beams and 1.35 for slabs. Note that  $f_s$  is in psi and  $W$  is in inches.

The mean ratio of maximum crack width to average crack width was found to vary between 1.5 and 2.0, as reported by many investigators. An average value of 1.75 may be used.

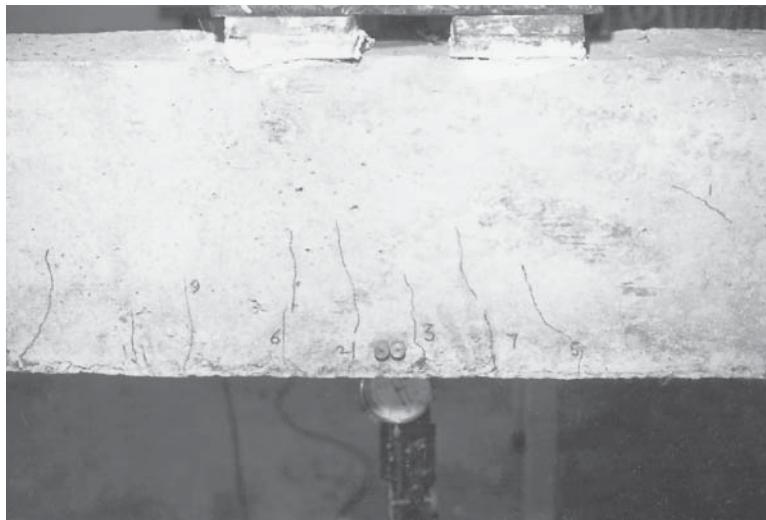
In SI units (mm and MPa), Eq. 6.15 is

$$W = 11.0\beta f_s \sqrt[3]{Ad_c} \times 10^{-6} \quad (6.16)$$

**Tolerable Crack Width.** The formation of cracks in reinforced concrete members is unavoidable. Hairline cracks occur even in carefully designed and constructed structures. Cracks are usually measured at the face of the concrete, but actually they are related to crack width at the steel level, where corrosion is expected. The permissible crack width is also influenced by aesthetic and appearance requirements. The naked eye can detect a crack about 0.006 in. (0.15 mm) wide, depending on the surface texture of concrete. Different values for permissible crack width at the steel level have been



(a)



(b)

**Figure 6.7** (a) Main cracks in a reinforced concrete beam. (b) Spacing of cracks in a reinforced concrete beam.

suggested by many investigators, ranging from 0.010 to 0.016 in. (0.25 to 0.40 mm) for interior members and from 0.006 to 0.010 in. (0.15 to 0.25 mm) for exterior exposed members. A limiting crack width of 0.016 in. (0.40 mm) for interior members and 0.013 in. (0.32 mm) for exterior members under dry conditions can be tolerated.

**Crack Control.** *Control* grows in importance with the use of high-strength steel in reinforced concrete members, as larger cracks develop under working loads because of the high allowable stresses. Control of cracking depends on the permissible crack width: It is always preferable to

have a large number of fine cracks rather than a small number of large cracks. Secondary cracks are minimized by controlling the total amount of cement paste, water–cement ratio, permeability of aggregate and concrete, rate of curing, shrinkage, and end-restraint conditions.

The factors involved in controlling main cracks are the reinforcement stress, the bond characteristics of reinforcement, the distribution of reinforcement, the diameter of the steel bars used, the steel percentage, the concrete cover, and the properties of concrete constituents. Any improvement in these factors will help in reducing the width of cracks.

## 6.7 ACI CODE REQUIREMENTS

To control cracks in reinforced concrete members, the ACI Code, Section 24.3, specifies the following:

1. Only deformed bars are permitted as main reinforcement.
2. Tension reinforcement should be well distributed in the zones of maximum tension (ACI Code, Sections 11.7.2.4 and 24.3.1).
3. When the flange of the section is under tension, part of the main reinforcement should be distributed over the effective flange width or one-tenth of the span, whichever smaller. If the effective flange width exceeds one-tenth the span, some longitudinal reinforcement has to be provided in the outer portion of the flange (ACI Code, Section 24.3.4).
4. The design yield strength of reinforcement should not exceed 80 ksi (560 MPa) (ACI Code, Section 20.2.2.4).
5. The maximum spacing  $s$  of reinforcement closest to a concrete surface in tension in reinforced concrete beams and one-way slabs is limited to

$$s(\text{in.}) = \left[ 15 \left( \frac{40}{f_s} \right) - 2.5C_c \right] \quad (6.17)$$

but not greater than  $12(40/f_s)$ ,  
where

$f_s$  = calculated stress (ksi) in reinforcement at service load computed as unfactored moment divided by product of steel area and internal moment arm,  $f_s = M/(A_s jd)$  (alternatively,

$f_s = \frac{2}{3}f_y$  may be used; approximate value of  $jd = 0.87d$  may be used)

$C_c$  = clear cover from nearest surface in tension to surface of flexural tension reinforcement (in.)

$s$  = center-to-center spacing of flexural tension reinforcement nearest extreme concrete tension face (in.)

The preceding limitations are applicable to reinforced concrete beams and one-way slabs subject to normal environmental condition and do not apply to structures subjected to aggressive exposure. The spacing limitation just given is independent of the bar size, which may lead to the use of smaller bar sizes to satisfy the spacing criteria. For the case of concrete beams reinforced with grade 60 steel bars and  $C_c = 2$  in., clear cover to the tension face, the maximum spacing is calculated as follows: Assume  $f_s = 2/3 f_y = (2/3) \times 60 = 40$  ksi and  $s = 15 \left( \frac{40}{40} \right) - 2.5 \times 2 = 10$  in. (controls), which is less than  $12(40/40) = 12$  in.

6. In SI units, Eq. 6.17 becomes

$$s(\text{mm}) = 105,000/f_s - 2.5C_c \quad (6.18)$$

but not greater than  $300 (280/f_s)$ , where  $f_s$  is in 'MPa' and  $C_c$  is in 'mm'. For example, if bars with a clear cover equal to 50 mm are used, then the maximum spacing,  $s$ , is calculated as

$$s = \frac{105,000}{280} - 2.5 \times 50 = 250 \text{ mm (controls),}$$

which is less than  $300(280/280) = 300$  mm in this example. This is assuming that  $f_s = \frac{2}{3} \times 420 = 280$  MPa.

7. In the previous codes, control of cracking was based on a factor  $Z$  defined as follows:

$$\begin{aligned} Z = f_s \sqrt[3]{Ad_c} &\leq 175 \text{ k/in. (31 kN/mm) for interior members} \\ &\leq 140 \text{ k/in. (26 kN/mm) for exterior members} \end{aligned} \quad (6.19)$$

where  $f_s$  is the flexural stress at service load (ksi) and may be taken as  $0.6 f_y$  and  $A$  and  $d_c$  are the effective tension area of concrete and thickness of concrete cover, respectively. This expression is based on Eq. 6.15 assuming a limiting crack width of 0.016 in. for interior members and 0.013 in. for exterior members. It encouraged a decrease in the reinforcement cover to achieve a smaller  $Z$ , while unfortunately it penalized structures with concrete cover that exceeded 2 in.

8. *Skin Reinforcement.* For relatively deep girders, with a total depth,  $h$ , equal to or greater than 36 in. (900 mm), light reinforcement should be added near the vertical faces in the tension zone to control cracking in the web above the main reinforcement. The ACI Code, Section 9.7.2.3, referred to this additional steel as skin reinforcement. The skin reinforcement should be uniformly distributed along both side faces of the member for a distance  $h/2$  from the tension face.

The spacing  $S$  between the longitudinal bars or wires of the skin reinforcement shall be as provided in Eq. 6.17 where  $C_c$  is the least distance from the skin reinforcement to the side face.

Referring to Figure 6.8, if  $b = 16$  in.,  $h = 40$  in.,  $f_y = 60$  ksi, and choosing no. 3 bars spaced at 6.0 in. as skin reinforcement (three spaces on each side), then the height covered is equal to  $3 \times 6 + 2.5 = 20.5$  in., which is greater than  $h/2 = 40/2 = 20$  in.

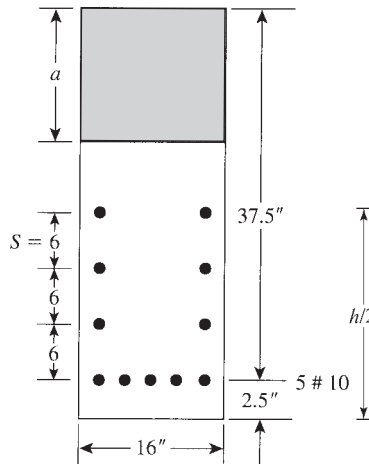


Figure 6.8 Skin reinforcement (six no. 3 bars).

Checking the spacing  $S$  by Eq. 6.18 and assuming  $f_s = 2/3f_y = 2/3 \times 60 = 40$  ksi, and  $C_c = 2$  in., then  $S = 15(40/40) - 2.5 \times 2 = 10$  in., which is less than  $12(40/40) = 12$  in. The spacing used is adequate. Note that  $C_c = 1.5$  in. may be used for the skin reinforcement concrete cover.

It is recommended to use smaller spacing to control the propagation of tensile cracks along the side of the tension zone with the first side bar to be placed at 4 to 6 in. from the main tensile steel.

### Example 6.6

The sections of a simply supported beam are shown in Fig. 6.9.

- Check if the bar arrangement satisfies the ACI Code requirements.
- Determine the expected crack width.
- Check the  $Z$ -factor based on Eq. 6.19.

Given:  $f'_c = 4$  ksi,  $f_y = 60$  ksi, and no. 3 stirrups.

### Solution

1. Fig. 6.9, section a:

- For three no. 8 bars,  $A_s = 2.35$  in.<sup>2</sup>, clear cover,  $C_c = 2.5 - 8/16 = 2.0$  in. Assume  $f_s = \frac{2}{3}f_y = 2/3 \times 60 = 40$  ksi. Maximum spacing  $s = 600/40 - 2.5 \times 2 = 10$  in., which is less than  $12(40/40) = 12$  in. Spacing provided equals  $0.5(12 - 2.5 - 2.5) = 3.5$  in., center to center of bars, which is less than 10 in.
- For this section,  $d_c = 2.5$  in. The effective tension area of concrete for one bar is

$$A = \frac{12(2 \times 2.5)}{3} = 20 \text{ in.}^2$$

Estimated crack width using Eq. 6.16 is

$$W = 0.076(1.2)(36,000)\sqrt[3]{20 \times 2.5 \times 10^{-6}} = 0.0121 \text{ in.}$$

This is assuming  $\beta = 1.2$  for beams and  $f_s = 36$  ksi. The crack width above is less than 0.016 in. and 0.013 in. for interior and exterior members.

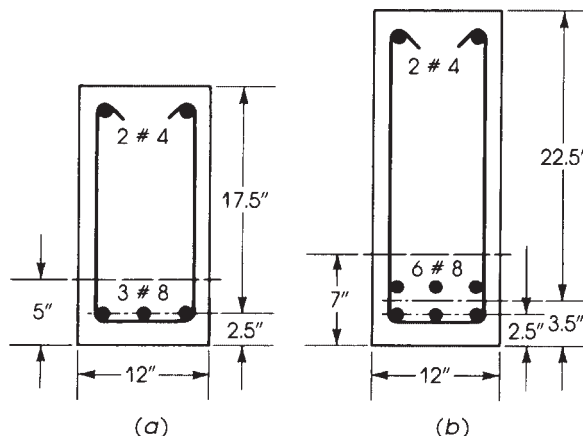


Figure 6.9 Two sections for Example 6.6.

2. Fig. 6.9, section *b*:

- a. Calculations of spacing of bars are similar to those in section *a*.
- b. For this section,  $d_c = 2.5$  in., and the steel bars are placed in two layers. The centroid of the steel bars is 3.5 in. from the bottom fibers. The effective tension concrete area is  $A = 12(2 \times 3.5)/6 = 14$  in.<sup>2</sup> Then

$$W = 0.076 \times 1.2 \times 36,000 \sqrt[3]{14 \times 2.5 \times 10^{-6}} = 0.0107 \text{ in.}$$

which is adequate.

### Discussion

It can be seen that the spacing,  $s$ , in Eq. 6.17 is a function of the stress in the tension bars or, indirectly, is a function of the strain in the tension steel,  $f_s = E_s \times \epsilon_s$ , and  $E_s$  for steel is equal to 29,000 ksi. The spacing also depends on the concrete cover,  $C_c$ . An increase in the concrete cover will reduce the limited spacing  $s$ , which is independent on the bar size used in the section.

In this example, the expected crack width was calculated by Eq. 6.17 to give the student or the engineer a physical feeling for the crack width and crack control requirement. The crack width is usually measured in beams when tested in the laboratory or else in actual structures under loading when serious cracks develop in beams or slabs and testing is needed. If the crack width measured before and after loading is greater than the yield strain of steel, then the main reinforcement is in the plastic range and ineffective. Sheets with lines of different thickness representing crack widths are available in the market for easy comparisons with actual crack widths. In addition to the steel stress and the concrete cover,  $W$  depends on a third factor,  $A$ , representing the tension area of concrete surrounding one bar in tension.

### Example 6.7

Design a simply supported beam with a span of 24 ft to carry a uniform dead load of 1.5 K/ft and a live load of 1.18 K/ft. Choose adequate bars; then check their spacing arrangement to satisfy the ACI Code. Given:  $b = 16$  in.,  $f'_c = 4$  ksi,  $f_y = 60$  ksi, a steel percentage = 0.8%, and a clear concrete cover of 2 in.

### Solution

1. For a steel percentage of 0.8%,  $R_u = 400$  psi = 0.4 ksi ( $\phi = 0.9$ ). The external factored moment is  $M_u = w_u \times L^2/8$ , and

$$w_u = 1.2(1.5) + 1.6(1.18) = 3.69 \text{ K/ft}$$

$$M_u = \frac{3.69(24)^2}{8} = 265.68 \text{ K} \cdot \text{ft} = 3188.2 \text{ K} \cdot \text{in.}$$

$$M_u = R_u b d^2 \quad d = 22.32 \quad A_s = 0.008 \times 16 \times 22.32 = 2.86 \text{ in.}^2$$

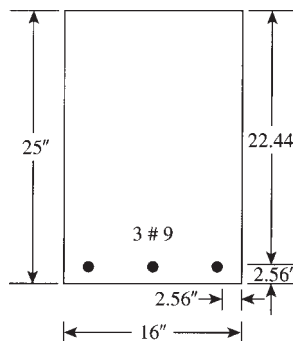


Figure 6.10 Example 6.7.

Choose three no. 9 bars (area = 3.0 in.<sup>2</sup>) in one row, and a total depth of  $h = 25.0$  in. Actual  $d = 25 - 2 - 9/16 = 22.44$  in. (Fig. 6.10).

2. Check spacing of bars using Eq. 6.18. Calculate the service load and moment,  $w = 1.5 + 1.18 = 2.68$  K/ft:

$$M = \frac{2.68(24)^2}{8} = 193 \text{ K} \cdot \text{ft} = 2315 \text{ K} \cdot \text{in.}$$

3. Calculate the neutral axis depth  $kd$  and the moment arm  $jd$  (Eq. 6.12):

$$\frac{1}{2}b(kd)^2 - nA_s(d - kd) = 0 \quad n = 8 \quad A_s = 3.0 \quad d = 22.44 \text{ in.}$$

$$kd = 6.85 \text{ in.} \quad jd = d - \frac{kd}{3} = 20.16 \text{ in.} \quad j = \frac{20.16}{22.44} = 0.898$$

Note that an approximate value of  $j = 0.87$  may be used if  $kd$  is not calculated.

4. Calculate the stress  $f_s$ :

$$M = A_s f_s jd \quad 2315 = 3(f_s)(20.16) \quad f_s = 38.3 \text{ ksi}$$

5. Calculate the spacing  $s$  by Eq. 6.18:

$$s = 600/38.3 - 2.5 \times 2 = 10.7 \text{ in.} \quad (\text{controls})$$

which is less than  $12(40/40) = 12.0$  in. Spacing provided =  $0.5(16 - 2.56 - 2.56) = 5.44$  in., which is less than 10.7 in.

### Example 6.8

Design a simply supported beam of 7.2-m span to carry a uniform dead load of 22.2 kN/m and a live load of 17 kN/m. Choose adequate bars, and check their spacing arrangement to satisfy the ACI Code.

Given:  $b = 400$  mm,  $f'_c = 30$  MPa,  $f_y = 400$  MPa, a steel percentage of 0.8%, and a clear concrete cover of 50 mm.

### Solution

1. For a steel percentage of 0.008 and from Eq. 3.22,  $R_u = 2.7$  MPa. Factored load  $w_u = 1.2(22.2) + 1.6(17) = 53.8$  kN/m. Then  $M_u = w_u L^2/8 = 53.8(7.2)^2/8 = 348.6$  kN · m;  $M_u = R_u \cdot b d^2$ , or  $348.6 \times 10^6 = 2.7 \times 400 d^2$ ,  $d = 568$  mm,  $A_s = \rho b d = 0.008 \times 400 \times 568 = 1818$  mm<sup>2</sup>. Choose four bars, 25 mm (no. 25 M),  $A_s = 2040$  mm<sup>2</sup>, in one row ( $b_{\min} = 220$  mm). Let  $h = 650$  mm, the actual  $d = 650 - 50 - 25/2 = 587.5$  mm, say 585 mm. Final section:  $b = 400$  mm,  $h = 650$  mm, with four no. 25 mm bars (Fig. 6.11).

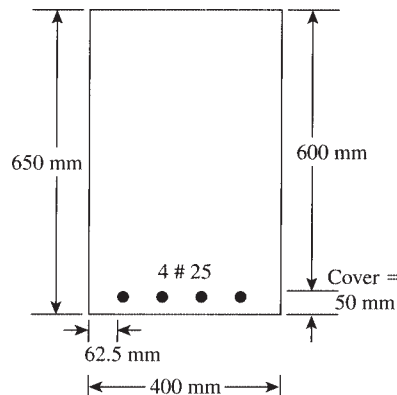


Figure 6.11 Example 6.8.

2. Check spacing of bars using Eq. 6.17. Calculate the service load moment,  $w = 22.2 + 17 = 39.2$  kN/m,

$$M = \frac{39.2(7.2)^2}{8} = 254 \text{ kN} \cdot \text{m}$$

Calculate  $kd$  and  $jd$  as in the previous example. Alternatively, use a moment arm,  $jd = 0.87d = 0.87(585) = 509$  mm and  $f_s = M/(A_s \cdot jd) = 254(10)^6 / (2040 \times 509) = 244.6$  MPa. From Eq. 6.19, maximum  $s = (105,000/244.6) - 2.5(50) = 304$  mm (controls), which is less than  $300(280/f_s) = 300(280)/244.6 = 343$  mm. Note that if  $f_s = 0.6 f_y = 0.6(400) = 240$  MPa is used, then maximum  $s = 312$  mm. It is preferable to calculate  $f_s$  from the moment equation to reflect the actual stress in the bars. Spacing provided  $= (1/3)(400 - 50 - 25) = 92$  mm, which is adequate.

## SUMMARY

### Sections 6.1 and 6.2

1. Deflection  $\Delta = \alpha(WL^3/EI) = 5WL^3/384EI = 5wL^4/384EI$  for a simply supported beam subjected to a uniform total load of  $W = wL$ :

$$E_c = 33w^{1.5} \sqrt{f'_c} = 57,400 f'_c \text{ psi}$$

for normal-weight concrete.

2. Effective moment of inertia is

$$I_e = \left( \frac{M_{cr}}{M_a} \right)^3 I_g + \left[ 1 - \left( \frac{M_{cr}}{M_a} \right)^3 \right] I_{cr} \leq I_g$$

$$M_{cr} = f_r \times \frac{I_g}{y_t} \quad \text{and} \quad f_r = 7.5 \lambda \sqrt{f'_c}$$

### Section 6.3

The deflection of reinforced concrete members continues to increase under sustained load.

Additional long-time deflection equals  $\zeta_\Delta \times$  instantaneous deflection:

$$\zeta_\Delta = \frac{\zeta}{1 + 50\rho'}$$

where  $\zeta = 1.0, 1.2, 1.4, 2.0$  for periods of 3, 6, 12, and 60 months, respectively.

### Sections 6.4 and 6.5

1. The allowable deflection varies between  $L/180$  and  $L/480$ .
2. Deflections for different types of loads may be calculated for each type of loading separately and then added algebraically to obtain the total deflection.

### Section 6.6

1. Cracks are classified as secondary cracks (shrinkage, corrosion, or secondary flexural cracks) and main cracks.



2. Maximum crack width is

$$W = 0.076\beta f_s \sqrt[3]{Ad_c} \times 10^{-6} (\text{in.})$$

Approximate values for  $\beta$ ,  $f_s$ , and  $d_c$  are  $\beta = 1.2$  for beams and  $\beta = 1.35$  for slabs,  $d_c = 2.5$  in., and  $f_s = (2/3)f_y$ .

3. The limiting crack width is 0.016 in. for interior members and 0.013 in. for exterior members.

### Section 6.7

The maximum spacing  $s$  of bars closest to a concrete surface in tension is limited to

$$s = \frac{600}{f_s} - 2.5C_c$$

but not more than  $12(40/f_s)$ . Note that  $f_s$  may be taken as  $2/3 f_y$ .

## REFERENCES

1. W-W. Yu and G. Winter. "Instantaneous and Longtime Deflections of Reinforced Concrete Beams under Working Loads." *ACI Journal* 57 (July 1960).
2. M. N. Hassoun. "Evaluation of Flexural Cracks in Reinforced Concrete Beams." *Journal of Engineering Sciences* 1, no. 1 (January 1975). College of Engineering, Riyadh, Saudi Arabia.
3. D. W. Branson. "Instantaneous and Time-Dependent Deflections of Simply and Continuous Reinforced Concrete Beams, Part 1." Alabama Highway Research Report no. 7, August 1989.
4. ACI Committee 435. "Allowable Deflections." *ACI Journal* 65 (June 1968 and reapproved).
5. ACI Committee 435. "Deflections of Continuous Beams." *ACI Journal* 70 (December 1973 and 1989).
6. ACI Committee 435. "Variability of Deflections of Simply Supported Reinforced Concrete Beams." *ACI Journal* 69 (January 1972).
7. D. E. Branson. *Deformation of Concrete Structures*. McGraw-Hill, New York, 1977.
8. American Concrete Institute (ACI). *Causes, Mechanism and Control of Cracking in Concrete*. ACI Publication SP-20. ACI, Detroit, MI, 1968.
9. R. Salinger. "High Grade Steel in Reinforced Concrete." In *Proceedings of the 2nd Congress of International Association for Bridge and Structural Engineering*. Berlin-Munich, 1936.
10. K. Billing. *Structural Concrete*. St. Martins Press, New York, 1960.
11. P. E. Halstead. "The Chemical and Physical Effects of Aggressive Substances on Concrete." *Structural Engineer* 40 (1961).
12. R. E. Stratfull. "The Corrosion of Steel in a Reinforced Concrete Bridge." *Corrosion* 13, no. 3 (March 1957).
13. C. L. Shermer. "Corroded Reinforcement Destroys Concrete Beams." *Civil Engineering* 26 (December 1956).
14. V. R. Evans. *An Introduction to Metallic Corrosion*. Edward Arnold, London, 1948.
15. J. D. Mozer, A. Bianchini, and C. Kesler. "Corrosion of Steel Reinforcement in Concrete." Report No. 259. University of Illinois, Department of Theoretical and Applied Mechanics, April 1964.
16. M. Chi and A. F. Kirstein. "Flexural Cracks in Reinforced Concrete Beams." *ACI Journal* 54 (April 1958).
17. R. C. Mathy and D. Watstein. "Effect of Tensile Properties of Reinforcement on the Flexural Characteristics of Beams." *ACI Journal* 56 (June 1960).
18. F. Levi. "Work of European Concrete Committee." *ACI Journal* 57 (March 1961).
19. E. Hognestad. "High-Strength Bars as Concrete Reinforcement." *Journal of the Portland Cement Association, Development Bulletin* 3, no. 3 (September 1961).

20. P. H. Kaar and A. H. Mattock. "High-Strength Bars as Concrete Reinforcement (Control of Cracking), Part 4." *PCA Journal* 5 (January 1963).
21. B. B. Broms. "Crack Width and Crack Spacing in Reinforced Concrete Members." *ACI Journal* 62 (October 1965).
22. G. D. Base, J. B. Reed, and H. P. Taylor. "Discussion on 'Crack and Crack Spacing in Reinforced Concrete Members.'" *ACI Journal* 63 (June 1966).
23. P. Gergely and L. A. Lutz. "Maximum Crack Width in Reinforced Concrete Flexural Members." In *Causes, Mechanism and Control of Cracking in Concrete*. ACI Publication SP-20. American Concrete Institute, Dearborn, MI, 1968.
24. ACI Committee 224. "Control of Cracking in Concrete Structures." ACI 224R-01 (approved 2008). *Manual of Concrete Practice Part 1*, American Concrete Institute, Dearborn, MI, 2010.
25. ACI Committee 224. "Causes, Evaluation, and Repair of Cracks in Concrete Structures." ACI 224.1R-07. *Manual of Concrete Practice, Part 1*, American Concrete Institute, Dearborn, MI, 2010.
26. M. N. Hassoun and K. Sahebjudm. *Cracking of Partially Prestressed Concrete Beams*. ACI Special Publications SP-113. American Concrete Institute, Dearborn, MI, 1989.

### PROBLEMS

- 6.1 Determine the instantaneous and long-time deflection of a 20-ft-span simply supported beam for each of the following load conditions. Assume that 10% of the live loads are sustained and the dead loads include the self-weight of the beams. Use  $f'_c = 4$  ksi,  $f_y = 60$  ksi,  $d' = 2.5$  in., and a time limit of 5 years. Refer to Fig. 6.12.

No.	$b$ (in.)	$d$ (in.)	$h$ (in.)	$A_s$ (in. <sup>2</sup> )	$A'_s$ (in. <sup>2</sup> )	$W_D$ (K/ft)	$W_L$ (K/ft)	$P_D$ (K)	$P_L$ (K)
<i>a</i>	14	17.5	20	5 no. 9	—	2.2	1.8	—	—
<i>b</i>	20	27.5	30	6 no. 10	—	7.0	3.6	—	—
<i>c</i>	12	19.5	23	6 no. 8	—	3.0	1.5	—	—
<i>d</i>	18	20.5	24	6 no. 10	2 no. 9	6.0	2.0	—	—
<i>e</i>	16	22.5	26	6 no. 11	2 no. 10	5.0	3.2	12	10
<i>f</i>	14	20.5	24	8 no. 9	2 no. 9	3.8	2.8	8	6

Note:  $h-d = 2.5$  in. indicates one row of bars, whereas  $h-d = 3.5$  in. indicates two rows of bars. Concentrated loads are placed at midspan.

- 6.2 Determine the instantaneous and long-term deflection of the free end of a 12-ft-span cantilever beam for each of the following load conditions. Assume that only dead loads are sustained, and the dead loads

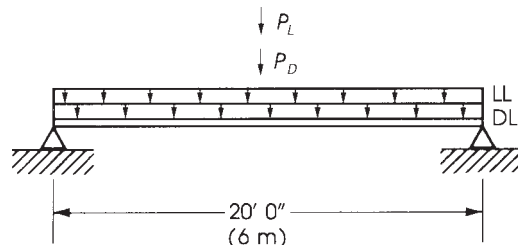


Figure 6.12 Problem 6.1.

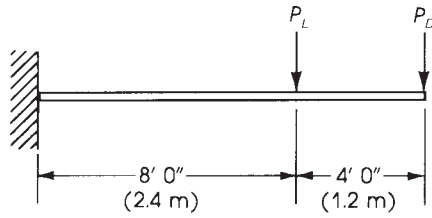


Figure 6.13 Problem 6.2.

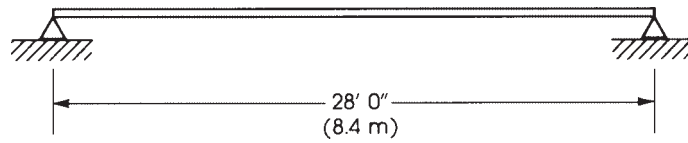


Figure 6.14 Dead load = 2 K/ft (30 kN/m) and live load = 1.33 K/ft (20 kN/m).

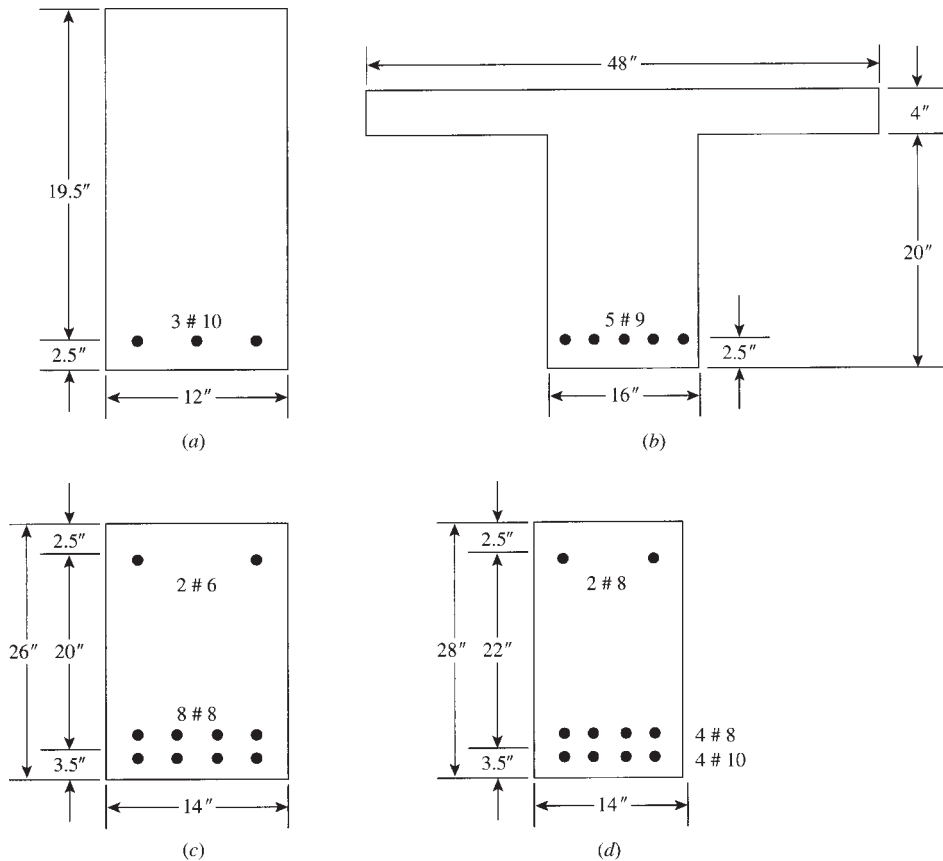
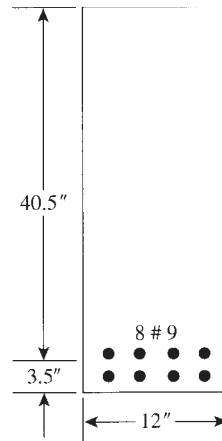


Figure 6.15 Problem 6.5.



**Figure 6.16** Skin reinforcement.

include the self-weight of the beams. Use  $f'_c = 4$  ksi,  $f_y = 60$  ksi, and a time limit of more than 5 years. Refer to Fig. 6.13.

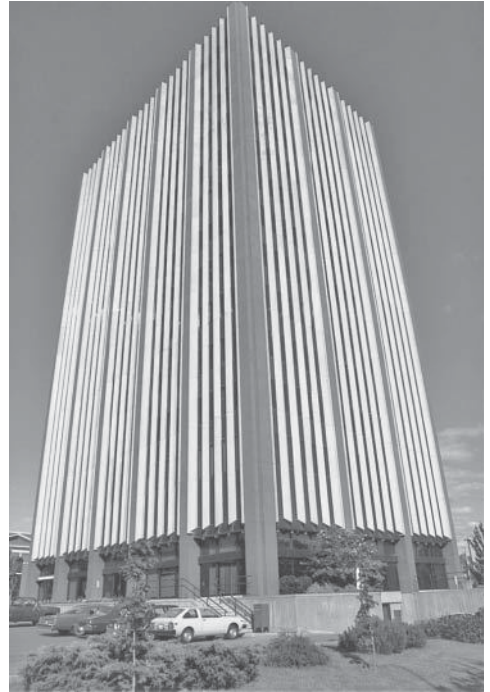
No.	$b$ (in.)	$d$ (in.)	$h$ (in.)	$A_s$ (in. <sup>2</sup> )	$A'_s$ (in. <sup>2</sup> )	$W_D$ (K/ft)	$W_L$ (K/ft)	$P_D$ (K)	$P_L$ (K)
<i>a</i>	15	20.5	24	8 no. 9	2 no. 9	3.5	2.0	—	—
<i>b</i>	18	22.5	26	6 no. 10	—	2.0	1.5	7.4	5.0
<i>c</i>	12	19.5	23	8 no. 8	2 no. 8	2.4	1.6	—	—
<i>d</i>	14	20.5	24	8 no. 9	2 no. 9	3.0	1.1	5.5	4.0

Note  $h-d = 2.5$  in. indicates one row of bars, whereas  $h-d = 3.5$  in. indicates two rows of bars. Concentrated loads are placed as shown.

- 6.3** A 28-ft simply supported beam carries a uniform dead load of 2 K/ft (including self-weight) and a live load of 1.33 K/ft. Design the critical section at midspan using the maximum steel ratio allowed by the ACI Code and then calculate the instantaneous deflection. Use  $f'_c = 4$  ksi,  $f_y = 60$  ksi, and  $b = 12$  in. See Fig. 6.14.
- 6.4** Design the beam in Problem 6.3 as doubly reinforced, considering that compression steel resists 20% of the maximum bending moment. Then calculate the maximum instantaneous deflection.
- 6.5** The four cross sections shown in Fig. 6.15 belong to four different beams with  $f'_c = 4$  ksi and  $f_y = 60$  ksi. Check the spacing of the bars in each section according to the ACI Code requirement using  $f_s = 0.6f_y$ . Then calculate the tolerable crack width,  $W$ .
- 6.6** Determine the necessary skin reinforcement for the beam section shown in Fig. 6.16. Then choose adequate bars and spacings. Use  $f'_c = 4$  ksi and  $f_y = 60$  ksi.

# CHAPTER 7

## DEVELOPMENT LENGTH OF REINFORCING BARS



Reinforced concrete columns supporting an office building, Toronto, Canada.

### 7.1 INTRODUCTION

The joint behavior of steel and concrete in a reinforced concrete member is based on the fact that a bond is maintained between the two materials after the concrete hardens. If a straight bar of round section is embedded in concrete, a considerable force is required to pull the bar out of the concrete. If the embedded length of the bar is long enough, the steel bar may yield, leaving some length of the bar in the concrete. The bonding force depends on the friction between steel and concrete. It is influenced mainly by the roughness of the steel surface area, the concrete mix, shrinkage, and the cover of concrete. Deformed bars give a better bond than plain bars. Rich mixes have greater adhesion than weak mixes. An increase in the concrete cover will improve the ultimate bond stress of a steel bar [2].

In general, the bond strength is influenced by the following factors:

1. Yield strength of reinforcing bars,  $f_y$ . Longer development length is needed with higher  $f_y$ .
2. Quality of concrete and its compressive strength,  $f'_c$ . An increase in  $f'_c$  reduces the required development length of reinforcing bars.
3. Bar size, spacing, and location in the concrete section. Horizontal bars placed with more than 12 in. of concrete below them have lower bond strength due to the fact that concrete shrinks and settles during the hardening process. Also, wide spacings of bars improve the bond strength, giving adequate effective concrete area around each bar.
4. Concrete cover to reinforcing bars. A small cover may cause the cracking and spalling of the concrete cover.
5. Confinement of bars by lateral ties. Adequate confinement by ties or stirrups prevents the spalling of concrete around bars.

## 7.2 DEVELOPMENT OF BOND STRESSES

### 7.2.1 Flexural Bond

Consider a length  $dx$  of a beam subjected to uniform loading. Let the moment produced on one side be  $M_1$  and on the other side be  $M_2$  with  $M_1$  being greater than  $M_2$ . The moments will produce internal compression and tension forces, as shown in Fig. 7.1. Because  $M_1$  is greater than  $M_2$ ,  $T_1$  is greater than  $T_2$ ; consequently,  $C_1$  is greater than  $C_2$ .

At any section,  $T = M/jd$ , where  $jd$  is the moment arm:

$$T_1 - T_2 = dT = \frac{dM}{jd}$$

but

$$T_1 = T_2 + u \sum O dx$$

where  $u$  is the average bond stress and  $\sum O$  is the sum of perimeters of bars in the section at the tension side. Therefore,

$$T_1 - T_2 = u \sum O dx = \frac{dM}{jd}$$

$$u = \frac{dM}{dx} \times \frac{1}{jd \sum O}$$

The rate of change of the moment with respect to  $x$  is the shear, or  $dM/dx = V$ . Therefore,

$$u = \frac{V}{jd \sum O} \quad (7.1)$$

The value  $u$  is the average bond stress; for practical calculations,  $j$  can be taken to be approximately equal to 0.87:

$$u = \frac{V}{0.87d \sum O}$$

In the strength design method, the nominal bond strength is reduced by the capacity reduction factor,  $\phi = 0.75$ . Thus,

$$U_u = \frac{V_u}{\phi(0.87)d \sum O} \quad (7.2)$$

Based on the preceding analysis, the bond stress is developed along the surface of the reinforcing bar due to shear stresses and shear interlock.

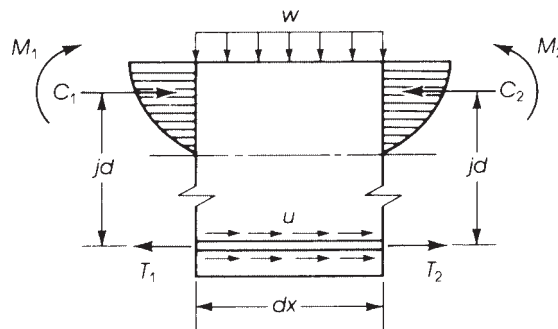
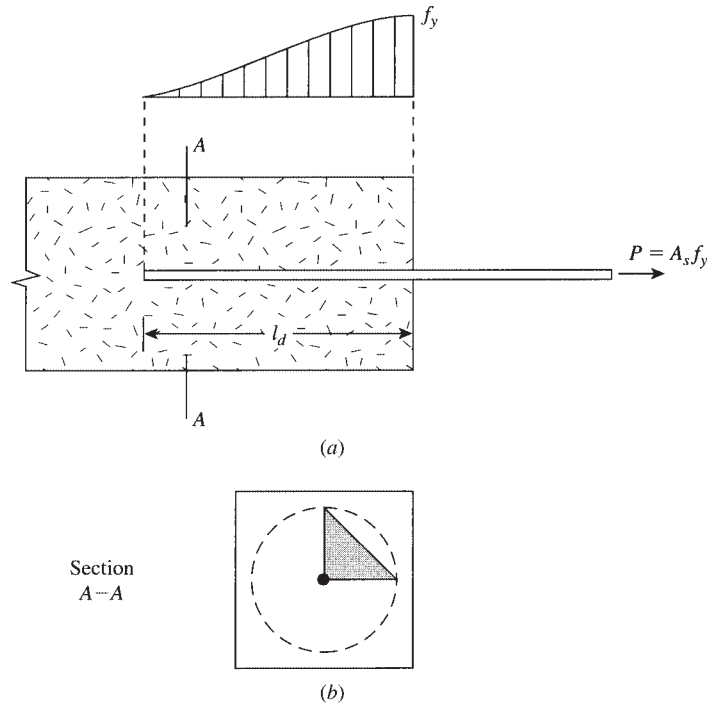


Figure 7.1 Flexural bond.



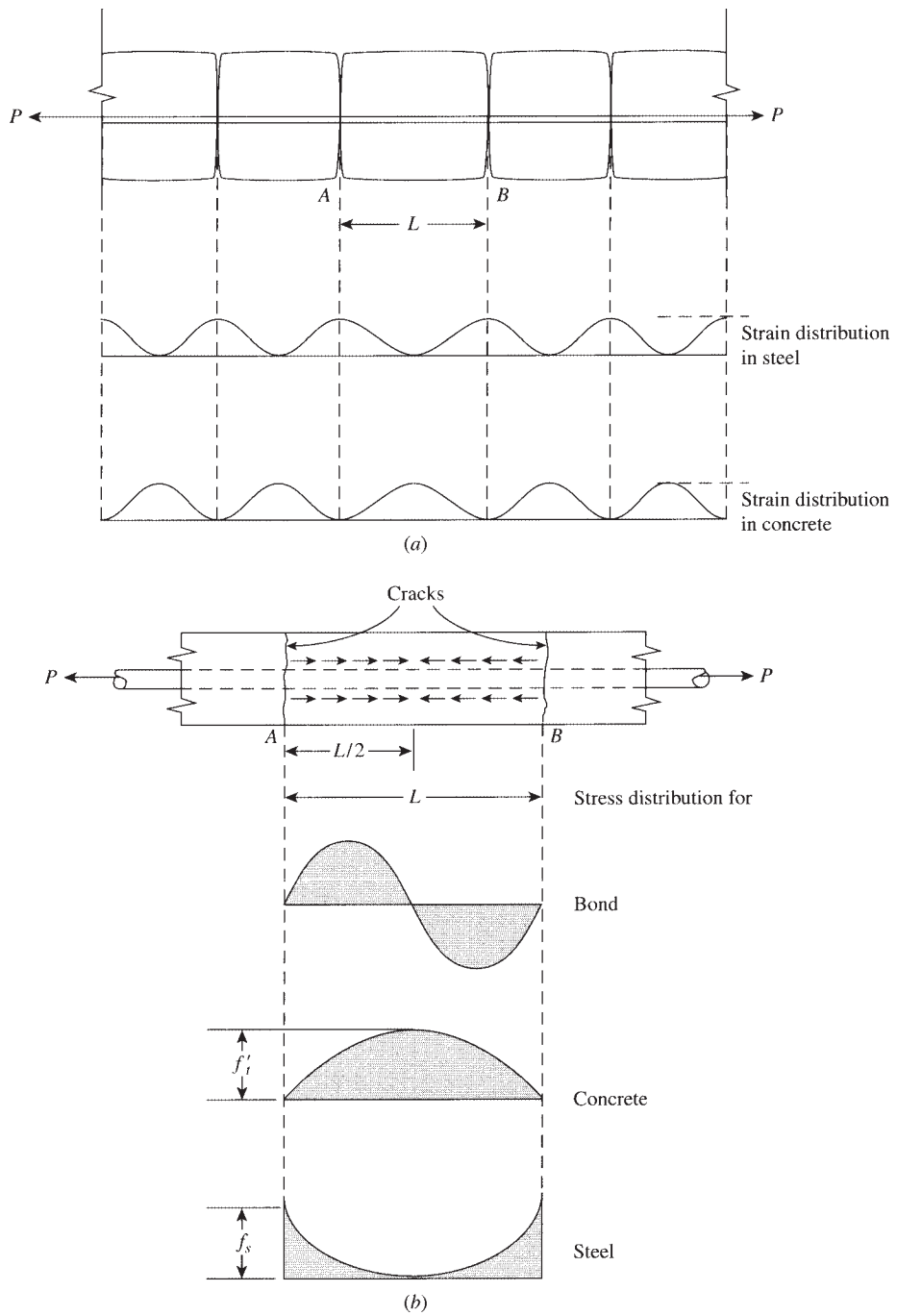
**Figure 7.2** Bond stresses and development length. (a) Distribution of stress along  $l_d$  and (b) radial stress in concrete around the bar.

### 7.2.2 Tests for Bond Efficiency

Tests to determine the bond stress capacity can be made using the pullout test (Fig. 7.2). This test evaluates the bond capacity of various types of bar surfaces relative to a specific embedded length. The distribution of tensile stresses will be uniform around the reinforcing bar at a specific section and varies along the anchorage length of the bar and at a radial distance from the surface of the bar (Fig. 7.2). However, this test does not represent the effective bond behavior in the surface of the bars in flexural members because stresses vary along the depth of the concrete section. A second type of test can be performed on an embedded rod (Fig. 7.3). In these tests, the tensile force,  $P$ , is increased gradually and the number of cracks and their spacings and widths are recorded. The bond stresses vary along the bar length between the cracks. The strain in the steel bar is maximum at the cracked section and decreases toward the middle section between cracks.

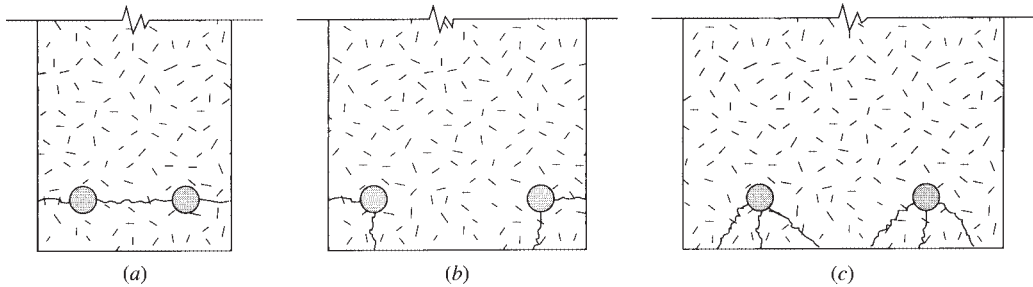
Tests on flexural members are also performed to study the bond effectiveness along the surface of the tension bars. The analysis of bond stresses in the bars of these members was explained earlier, and they are represented by Eq. 7.2.

Based on this discussion, it is important to choose an appropriate length in each reinforcing bar to develop its full yield strength without a failure in the bond strength. This length is called the *development length*,  $l_d$ . If this length is not provided, the bond stresses in the tension zone of a beam become high enough to cause cracking and splitting in the concrete cover around the tension bars (Fig. 7.4). If the split continues to the end of the bar, the beam will eventually fail. Note that small spacings between tensile bars and a small concrete cover on the sides and bottom will reduce the bond capacity of the reinforcing bars (Fig. 7.4).



**Figure 7.3** Bond mechanism in an embedded bar. (a) Strain and (b) stress distribution between cracks.





**Figure 7.4** Examples of spalling of concrete cover. (a) High bottom cover, (b) wide spacing, and (c) small bottom cover.

## 7.3 DEVELOPMENT LENGTH IN TENSION

### 7.3.1 Development Length, $l_d$

If a steel bar is embedded in concrete, as shown in Fig. 7.2, and is subjected to a tension force  $T$ , then this force will be resisted by the bond stress between the steel bar and the concrete. The maximum tension force is equal to  $A_s f_y$ , where  $A_s$  is the area of the steel bar. This force is resisted by another internal force of magnitude  $U_u O l_d$ , where  $U_u$  is the ultimate average bond stress,  $l_d$  is the embedded length of the bar, and  $O$  is the perimeter of the bar ( $\pi D$ ). The two forces must be equal for equilibrium:

$$A_s f_y = U_u O l_d \quad \text{and} \quad l_d = \frac{A_s f_y}{U_u O}$$

For a combination of bars,

$$l_d = \frac{A_s f_y}{U_u \sum O} \quad (7.3)$$

The length  $l_d$  is the minimum permissible anchorage length and is called the development length:

$$l_d = \frac{\pi d_b^2 f_y}{4 U_u (\pi d_b)} = \frac{d_b f_y}{4 U_u} \quad (7.4)$$

where  $d_b$  is the diameter of reinforcing bars.

This means that the development length is a function of the size and yield strength of the reinforcing bars in addition to the ultimate bond stress, which in turn is a function of  $\sqrt{f'_c}$ . The bar length  $l_d$  given in Eq. 7.4 is called the *development length*,  $l_d$ . The final development length should also include the other factors mentioned in Section 7.1. Equation 7.4 may be written as follows:

$$\frac{l_d}{d_b} = K \left( \frac{f_y}{\sqrt{f'_c}} \right) \quad (7.5)$$

where  $K$  is a general factor that can be obtained from tests to include factors such as the bar characteristics (bar size, spacing, epoxy coated or uncoated, location in concrete section, and bar splicing), amount of transverse reinforcement, and the provision of excess reinforcement compared to that required from design.

The ACI Code, Section 25.4.2.3, evaluated  $K$  as follows:

$$K = \left( \frac{3}{40\lambda} \right) \left( \frac{\psi_t \psi_e \psi_s}{(c_b + K_{tr}) / d_b} \right) \quad (7.6)$$

and 7.5 becomes

$$\frac{l_d}{d_b} = \left( \frac{3}{40\lambda} \right) \left( \frac{f_y}{\sqrt{f'_c}} \right) \left( \frac{\psi_t \psi_e \psi_s}{(c_b + K_{tr}) / d_b} \right) \quad (7.7)$$

where

$\psi_t$  = bar location

$\psi_e$  = coating factor

$\psi_s$  = bar-size factor

$\lambda$  = lightweight aggregate concrete factor (ACI Code, Section 19.2.4.2)

= 1.0 normal-weight concrete

= When lightweight aggregate is used,  $\lambda$  shall not exceed 0.75 unless splitting tensile strength is specified, then

$\lambda = f_{ct} / (6.7\sqrt{f'_c}) \leq 1$  (ACI Code, Section 19.2.4.2)  $c_b$  = spacing or cover dimension (in.); the smaller of

- (1) Distance from center of bar or wire being developed to the nearest concrete surface or
- (2) One-half the center-to-center spacing of bars or wires being developed

$K_{tr}$  = transverse reinforcement index

=  $40 A_{tr} / sn$

$n$  = number of bars or wires being developed along the plane of splitting

$s$  = maximum spacing of transverse reinforcement within  $l_d$ , center to center (in.)

$f_{yt}$  = yield strength of transverse reinforcement (psi)

$A_{tr}$  = total sectional area of all transverse reinforcement within spacing  $s$  that crosses the potential plane of splitting through to the reinforcement being developed (in.<sup>2</sup>)

*Notes:*

1. Let  $(c_b + K_{tr}) / d_b$  not exceed 2.5 to safeguard against pullout-type failures.
2. The value of  $\sqrt{f'_c}$  shall not exceed 100 psi (ACI Code, Section 25.4.1.4).
3. Let  $K_{tr} = 0$  be used as a design simplification (ACI Code, Section 25.4.2.3).

### 7.3.2 ACI Code Factors for Calculating $l_d$ for Bars in Tension

1.  $\Psi_t$  = bar location factor

$\Psi_t = 1.3$  for top bars defined as horizontal reinforcement, placed so that more than 12 in. of fresh concrete is below the development length, or splice

$\Psi_t = 1.0$  for all other reinforcement

2.  $\Psi_e$  = coating factor

$\Psi_e = 1.5$  for epoxy-coated bars or wires with cover less than  $3d_b$  or clear spacing less than  $6d_b$

$\Psi_e = 1.2$  for all other epoxy coated bars or wires

$\Psi_e = 1.0$  for uncoated and zinc-coated (galvanized) reinforcement (However, the value of the  $\Psi_t \Psi_e$  product should not exceed 1.7.)

3.  $\Psi_s$  = bar size factor

$\Psi_s = 0.8$  for no. 6 bars or smaller bars and deformed wires

$\Psi_s = 1.0$  for no. 7 bars and larger bars

4.  $\lambda$  = lightweight aggregate concrete factor

$$\lambda = \frac{6.7\sqrt{f'_c}}{f_{ct}} \leq 1.0$$

$\lambda = \lambda$  shall not exceed 0.75 unless  $f_{ct}$  is specified

$\lambda = 1.0$  for normal-weight concrete

5. The ACI Code permits using  $K_{tr} = 0$  even if transverse reinforcement is present. In this case,

$$\frac{l_d}{d_b} = \left(\frac{3}{40\lambda}\right) \left(\frac{f_y}{\sqrt{f'_c}}\right) \left(\frac{\psi_t\psi_e\psi_s}{c_b/d_b}\right) \quad (7.8)$$

The value of  $\sqrt{f'_c}$  should not exceed 100 psi.

6. Assume  $R_s$  is the reduction factor due to excess reinforcement. The ACI Code, Section 25.4.10.1, permits the reduction of  $l_d$  by the factor  $R_s$  when the reinforcement in a flexural member exceeds that required by analysis. This reduction does not apply when the full  $f_y$  development is required, as for tension lap splices, specified in ACI Code, Sections 4.10 and 25.5.2.1, and ACI Code, Section 8.7.4.2, development of positive-moment reinforcement at supports, and for development of shrinkage and temperature reinforcement.

This reduction in development length is not permitted for reinforcement in structures located in seismic risk or for structures assigned to high seismic performance or design categories, except where anchorage or development for  $f_y$  is specifically required or the reinforcement is designed considering seismic effects.

$$R_s = \frac{A_s(\text{required})}{A_s(\text{provided})} \quad (7.9)$$

7. The development length,  $l_d$ , in all cases shall not be less than 12 in. (ACI Code, Section 25.4.2.1)

### 7.3.3 Simplified Expressions for $l_d$

As design simplification, ACI Code permits to take  $k_{tr} = 0$  even if transverse reinforcement is present. To further simplify computation of  $l_d$ , preselected value of term  $(c_b + k_{tr})/d_b$  were chosen. As a result Eq. 7.7 can take the simplified forms specified in ACI Code, Section 25.4.2.2. These are shown in Eqs. 7.10 to 7.13:

$$\frac{l_d}{d_b} = \begin{cases} \frac{f_y\psi_t\psi_e}{25\lambda\sqrt{f'_c}} & \text{(no. 6 and smaller bar)} & (7.10) \\ \frac{f_y\psi_t\psi_e}{20\lambda\sqrt{f'_c}} & \text{(no. 7 and larger bars)} & (7.11) \\ \frac{3f_y\psi_t\psi_e}{50\lambda\sqrt{f'_c}} & \text{(no. 6 and smaller bars)} & (7.12) \\ \frac{3f_y\psi_t\psi_e}{40\lambda\sqrt{f'_c}} & \text{(no. 7 and larger bars)} & (7.13) \end{cases}$$

In Eqs. 7.10 and Eqs. 7.11 the term  $(c_b + k_{tr})/d_b = 1.5$ , while in Eqs. 7.12 and Eqs. 7.13  $(c_b + k_{tr})/d_b = 1.0$ . Equations 7.10 and 7.12 include a reinforcement size factor  $\psi_s = 0.8$ , while Eqs. 7.11 and Eqs. 7.13 include  $\psi_e = 1.0$ .

Equations 7.10 and 7.11 can only be applied if one of the following two different sets of conditions is satisfied:

Set 1: The following three conditions must simultaneously be satisfied:

1. The clear spacing of bars being developed or spliced should not be less than the diameter of reinforcement being developed ( $S \geq d_b$ ).
2. The clear cover for reinforcement being developed should not be less than  $d_b$ .
3. Minimum amount of stirrups or ties throughout  $l_d$  should not be less than the minimum value specified in ACI Code, Section 9.7.6.2, for beams or ACI Code, Section 9.7.6.4, for columns.

Set 2: The following two conditions must simultaneously be satisfied:

1. The clear spacing of reinforcement being developed or spliced should not be less than  $2d_b$ .
2. The clear cover should not be less than  $d_b$ .

If all the conditions of set 1 and set 2 cannot be satisfied then Eqs. 7.12 and Eqs. 7.13 must be used.

It is quite common to use  $f'_c = 4$  ksi and  $f_y = 60$  ksi in the design and construction of reinforced concrete buildings. If these values are substituted in the preceding equations, and assuming normal-weight concrete ( $\lambda = 1.0$ ), then

$$\text{Equation 7.10 becomes } l_d = 38d_b \quad (\leq \text{no. 6 bars}) \quad (7.10a)$$

$$\text{Equation 7.11 becomes } l_d = 47.5d_b \quad (\geq \text{no. 7 bars}) \quad (7.11a)$$

$$\text{Equation 7.12 becomes } l_d = 57d_b \quad (\leq \text{no. 6 bars}) \quad (7.12a)$$

$$\text{Equation 7.13 becomes } l_d = 71.2d_b \quad (\geq \text{no. 7 bars}) \quad (7.13a)$$

For design simplicity other values of  $l_d/d_b$  ratios are shown in Table 7.1. Table 7.2 gives the development length,  $l_d$ , for different reinforcing bars (when  $f_y = 40$  or 60 ksi and  $f'_c = 3$  and 4 ksi).

## 7.4 DEVELOPMENT LENGTH IN COMPRESSION

The development length of deformed bars in compression is generally smaller than that required for tension bars, due to the fact that compression bars do not have the cracks that develop in tension concrete members that cause a reduction in the bond between bars and the surrounding concrete.

**Table 7.1** Values of  $l_d/d_b$  for Various Values of  $f'_c$  and  $f_y$  (Tension Bars), ( $\lambda = 1.0$ )

$f'_c$ (ksi)	$f_y = 40$ ksi				$f_y = 60$ ksi			
	No. 6 Bars		$\geq$ No. 7 Bars	No. 6 Bars		$\geq$ No. 7 Bars		Other Cases
	Conditions Met	Other Cases	Conditions Met	Other Cases	Conditions Met	Other Cases		
3	29.3	43.9	36.6	54.8	43.9	65.8	54.8	82.2
4	25.3	38.0	31.7	47.5	38.0	57.0	47.5	71.2
5	22.7	34.0	28.3	42.5	34.0	51.0	42.5	63.7
6	20.7	31.0	25.9	38.8	31.0	46.5	38.8	58.1

**Table 7.2** Development Length  $l_d$  (in.) for Tension Bars and  $f_y = 60$  ksi ( $\psi_t = \psi_e = \lambda = 1.0$ )

Bar Number	Bar Diameter (in.)	Development Length $l_d$ (in.)— Tension Bars			
		$f'_c = 3$ ksi		$f'_c = 4$ ksi	
		Conditions Met	Other Cases	Conditions Met	Other Cases
3	0.375	17	25	15	21
4	0.500	22	33	19	29
5	0.625	28	41	24	36
6	0.750	33	50	29	43
7	0.875	48	72	42	63
8	1.000	55	83	48	72
9	1.128	62	93	54	81
10	1.270	70	105	61	92
11	1.410	78	116	68	102

The ACI Code, Section 25.4.9.2, gives the basic development length in compression for all bars as follows:

$$l_{dc} = \frac{0.02d_b f_y}{\lambda \sqrt{f'_c}} \geq 0.0003d_b f_y \quad (7.14)$$

which must not be less than 8 in. (ACI Code, Section 25.4.9.1). The development length,  $l_{dc}$ , may be reduced by multiplying  $l_{dc}$  by  $R_s = (A_s \text{ required}) / (A_s \text{ provided})$ . For spirally reinforced concrete compression members with spirals of not less than  $\frac{1}{4}$  in. diameter and a spacing of 4 in. or less, the value of  $l_{dc}$  in Eq. 7.14 may be multiplied by  $R_{s1} = 0.75$ . In general,  $l_d = l_{dc} \times (R_s \text{ or } R_{s1}, \text{ if applicable}) \geq 8$  in. Tables 7.3 and 7.4 give the values of  $l_{dc}/d_b$  when  $f_y = 60$  ksi.

**Table 7.3** Values of  $l_d/d_b$  for Various Values of  $f'_c$  and  $f_y$  (Compression Bars),  $\lambda = 1.0$ , Minimum  $l_{dc} = 8$  in.  $l_{dc}/d_b = 0.02f_y / \lambda \sqrt{f'_c} \geq 0.0003f_y$ 

$f'_c$ (ksi)	3	4	5 or more
$f_y = 40$ ksi	15	13	12
$f_y = 60$ ksi	22	19	18

**Table 7.4** Development Length,  $l_{dc}$  (in.), for Compression Bars ( $f_y = 60$  ksi),  $\lambda = 1.0$ 

Bar Number	Bar Diameter (in.)	Development Length, $l_{dc}$ (in.) when $f'_c =$		
		3 ksi	4 ksi	5 ksi or More
3	0.375	9	8	8
4	0.500	11	10	9
5	0.625	14	12	12
6	0.750	17	15	14
7	0.875	20	17	16
8	1.000	22	19	18
9	1.128	25	22	21
10	1.270	28	25	23
11	1.410	31	27	26

## 7.5 SUMMARY FOR COMPUTATION OF $l_d$ IN TENSION

Assuming normal construction practices,  $(c_b + K_{tr})/d_b = 1.5$ .

1. If one of the following two conditions is met:
  - a. Clear spacing of bars  $\geq d_b$ , clear cover  $\geq d_b$ , and bars are confined with stirrups not less than the code minimum.
  - b. Clear spacing of bars  $\geq 2d_b$  and clear cover  $\geq d_b$ ; then

$$\frac{l_d}{d_b} = \begin{cases} \frac{\psi_t \psi_e f_y}{20 \lambda \sqrt{f'_c}} & \text{for no. 7 and larger bars} \\ \frac{\psi_t \psi_e f_y}{25 \lambda \sqrt{f'_c}} & \text{for no. 6 or smaller bars} \end{cases} \quad \begin{matrix} \text{(Eq. 7.10)} \\ \text{(Eq. 7.11)} \end{matrix}$$

2. For all other cases, multiply these ratios by 1.5.
3. Note that  $\sqrt{f'_c} \leq 100$  psi and  $\psi_t \psi_e \leq 1.7$ ; values of  $\psi_t$ ,  $\psi_e$ , and  $\lambda$  are as explained earlier.
4. For bundled bars, either in tension or compression,  $l_d$  should be increased by 20% for three-bar bundles and by 33% for four-bar bundles. A unit of bundled bars is considered a single bar of a diameter and area equivalent to the total area of all bars in the bundle. This equivalent diameter is used to check spacings and concrete cover.

### Example 7.1

Figure 7.5 shows the cross section of a simply supported beam reinforced with four no. 8 bars that are confined with no. 3 stirrups spaced at 6 in. Determine the development length of the bars if the beam is made of normal-weight concrete, bars are not coated,  $f'_c = 3$  ksi, and  $f_y = 60$  ksi.

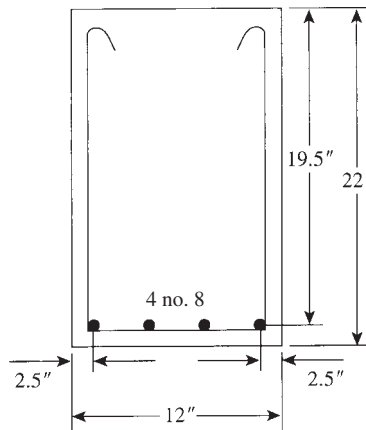


Figure 7.5 Example 7.1.

### Solution

1. Check if conditions for spacing and concrete cover are met:
  - a. For no. 8 bars,  $d_b = 1.0$  in.
  - b. Clear cover =  $2.5 - 0.5 = 2.0$  in.  $> d_b$ .
  - c. Clear spacing between bars  $\frac{12-5}{3} - 1.0 = 1.33 > d_b$

d. Bars are confined with no. 3 stirrup. The conditions are met. Then

$$\frac{l_d}{d_b} = \frac{\psi_t \psi_e f_y}{20 \lambda \sqrt{f'_c}} \quad (\text{for bars } > \text{ no. } 7) \quad (\text{Eq. 7.8})$$

2. Determine the multiplication factors:  $\psi_t = 1.0$  (bottom bars),  $\psi_e = 1.0$  (no coating), and  $\lambda = 1.0$  (normal-weight concrete). Also check that  $\sqrt{f'_c} = 54.8 \text{ psi} < 100 \text{ psi}$ .

$$\frac{l_d}{d_b} = \frac{60,000}{20 \times 1 \times \sqrt{3000}} = 54.8 \quad (\text{Eq. 7.7})$$

So,  $l_d = 54.8(1.0) = 54.8 \text{ in.}$ , say, 55 in. These values can be obtained directly from Tables 7.1 and 7.2.

If we calculate  $l_d$  from Eq. 7.7,

$$\begin{aligned} \frac{l_d}{d_b} &= \left(\frac{3}{40}\right) \left(\frac{f_y}{\sqrt{f'_c}}\right) \left(\frac{\psi_t \psi_e \psi_s}{(c_b + K_{tr})/d_b}\right) \\ &= \psi_t = \psi_e = \psi_s = \lambda = 1.0 \end{aligned}$$

Also  $c_b$  = smaller of distance from center of bar to the nearest concrete surface  $c_{b1}$  or one-half the center-to-center bar spacing  $c_{b2}$ :

$$c_{b1} = 2.5 \text{ in.} \quad c_{b2} = \left(\frac{1}{2}\right) \left(\frac{12 - 5}{3}\right) = 1.17 \text{ in.} \quad (\text{controls})$$

$$k_{tr} = \frac{40 A_{tr}}{sn}$$

$$A_{tr} = 2 \times (0.11) = 0.22 \text{ in.}^2$$

$$s = 6 \text{ in.}$$

$$n = 2$$

$$k_{tr} = \frac{40 \times 0.22}{2 \times 6} = 0.73$$

$$\frac{c_b + k_{tr}}{d_b} = \frac{1.17 + 0.73}{1.0} = 1.9 \text{ in.} < 2.5 \quad \text{OK}$$

$$\frac{l_d}{d_b} = \frac{3}{40} \left(\frac{6000}{\sqrt{3000}}\right) \left(\frac{1}{1.9}\right) = 43.24 \text{ in.}$$

$$l_d = 43.24(1.0) = 43.24 \text{ in.}$$

Say 44 in., which is 11 in. less than the simplified approach.

### Example 7.2

Repeat Example 7.1 if the beam is made of lightweight aggregate concrete, the bars are epoxy coated, and  $A_s$  required from analysis is  $2.79 \text{ in.}^2$

### Solution

1. Determine the multiplication factors:  $\psi_t = 1.0$  (bottom bars),  $\psi_e = 1.5$  (epoxy coated),  $\lambda = 0.75$  (lightweight aggregate concrete), and  $R_s = (A_s \text{ required}) / (A_s \text{ provided}) = 2.79 / 3.14 = 0.89$ .

The value of  $\psi_e$  is 1.5 because the concrete cover is less than  $3d_b = 3$  in. Check that  $\psi_t\psi_e = 1.0(1.5) = 1.5 < 1.7$  (Assuming  $k_{tr} = 0$ ).

2.

$$\begin{aligned} \frac{l_d}{d_b} &= \frac{R_s\psi_t\psi_e f_y}{20\lambda\sqrt{f'_c}} \quad (\text{for bars} > \text{no. } 7) \\ &= \frac{0.89(1.0)(1.5)(60,000)}{(20)(0.75)\sqrt{3000}} = 97.5 \text{ in. say, } 98 \text{ in.} \end{aligned}$$

3. The development length  $l_d$  can be obtained from Table 7.2 ( $l_d = 55$  in. for no. 8 bars) and then divided by the factor 0.75.

### Example 7.3

A reinforced concrete column is reinforced with eight no. 10 bars, which should extend to the footing. Determine the development length needed for the bars to extend down in the footing. Use normal-weight concrete with  $f'_c = 4$  ksi and  $f_y = 60$  ksi.

#### Solution

The development length in compression is

$$\begin{aligned} l_{dc} &= \frac{0.02d_b f_y}{\lambda\sqrt{f'_c}} \geq 0.0003d_b f_y \\ &= \frac{0.02(1.27)(60,000)}{(1)\sqrt{4000}} = 24.1 \text{ in. (controls)} \end{aligned}$$

The minimum  $l_{dc}$  is  $0.0003(1.27)(60,000) = 22.86$  in., but it cannot be less than 8 in. Because there are no other multiplication factors, then  $l_d = 24.1$  in., or 25 in. (The same value is shown in Table 7.4.)

## 7.6 CRITICAL SECTIONS IN FLEXURAL MEMBERS

The critical sections for development of reinforcement in flexural members are

- At points of maximum stress
- At points where tension bars within the span are terminated or bent
- At the face of the support
- At points of inflection at which moment changes signs

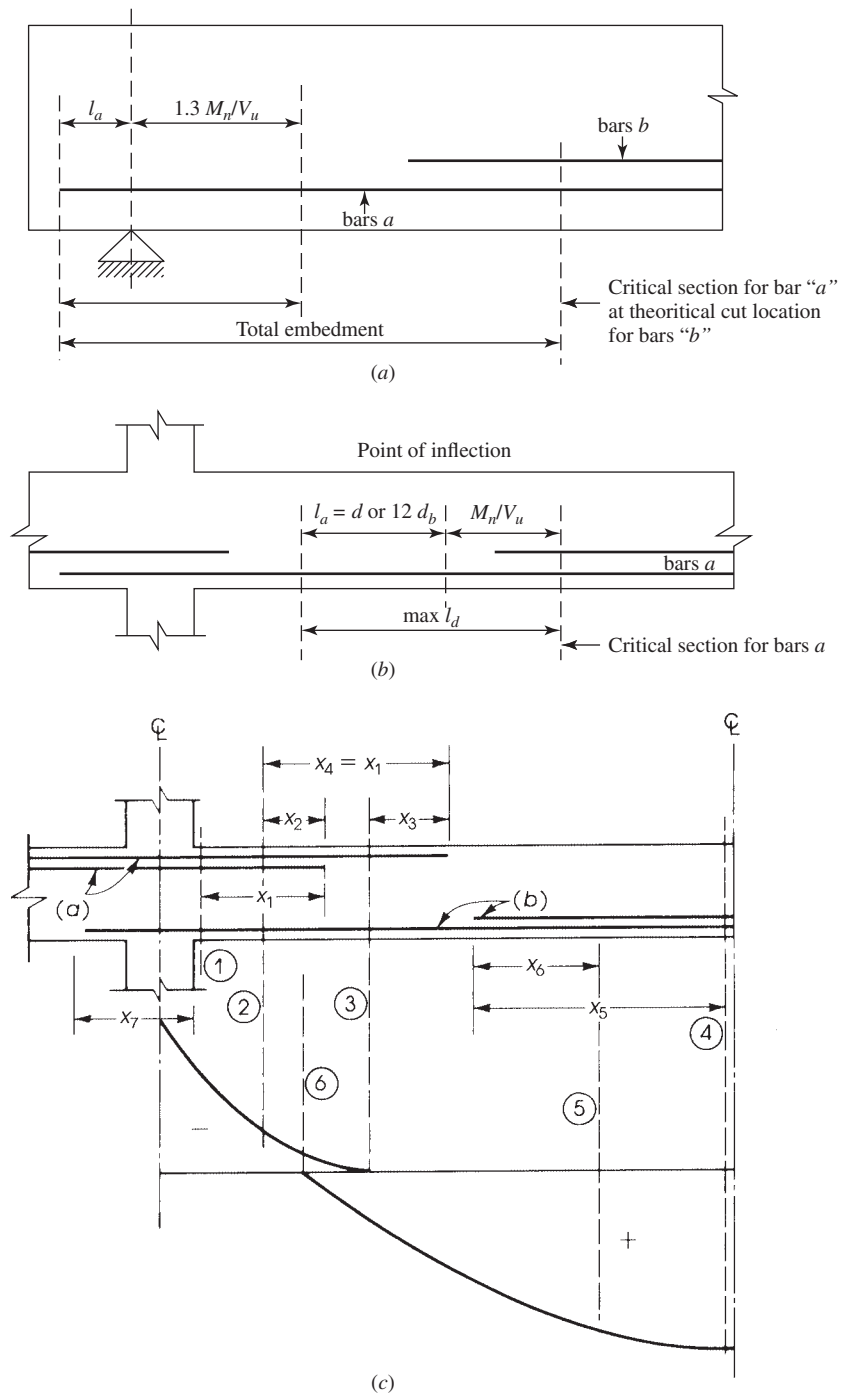
The critical sections for a typical uniformly loaded continuous beam are shown in Fig. 7.6. The sections and the relative development lengths are explained as follows:

1. Three sections are critical for the negative moment reinforcement:

Section 1 is at the face of the support, where the negative moment as well as stress is at maximum values. The distance  $x_1$  should be greater or equal the development length in tension  $l_d$  for all bars.

Section 2 is the section where part of the negative reinforcement bars are no longer needed to resist negative moment and can be terminated. To develop full tensile force, the bars should extend a distance  $x_2$  before they can be terminated. Once parts of the bars are terminated, the remaining bars develop maximum stress. The distance  $x_2$  should be the larger of  $d$  or 12 bar diameters.





**Figure 7.6** Critical sections (circled numbers) and development lengths ( $x_1 - x_7$ ).

Section 3 is at the point of inflection. The bars shall extend a distance  $x_3$ , which must be equal to or greater than the effective depth,  $d$ , 12 bar diameters, or 1/16th the clear span, whichever is greater. At least one-third of the total reinforcement provided for negative moment at the support shall be extended a distance  $x_3$  beyond the point of inflection, according to the ACI Code, Sections 7.7.3.8 and 9.7.3.8.

2. Three sections are critical for positive moment reinforcement:

Section 4 is that of maximum positive moment and maximum stresses. The distance  $x_5$  should be greater or equal the development length in tension  $l_d$  for all bars.

Section 5 is where parts of the positive reinforcement bars are no longer needed to resist positive moment and may be terminated. To develop full tensile force, the bars should extend a distance  $x_6$ . The remaining bars will have a maximum stress due to the termination of part of the bars. The distance  $x_6$  should be the larger of  $d$  or 12 bar diameters. At the face of support, section 1, at least one-third the positive moment reinforcement in simple members and one-fourth of the positive moment reinforcement in continuous members shall extend along the same face of the member into the support. In beams such reinforcement shall extend into the support 6 in. (ACI Code, Section 9.7.3.8.1). At the face of support section 1, the bottom bars should extend a distance  $x_7$  equal to the development length for compression  $l_{dc}$  when bottom bars used as compression reinforcement (ACI Code, Section 18.4.2).

Section 6 is at the point of inflection. ACI Code, Sections 7.7.3.8.3 and 9.7.3.8.3, specifies at simple supports and at points of inflection positive moment tension reinforcement shall be limited to a diameter such that the  $l_d$  computed for  $f_y$  shall satisfy following equation:

$$l_d \leq \frac{M_n}{V_u} + l_a \quad (\text{See Fig. 7.6b})$$

This equation needs not be satisfied for reinforcement terminating beyond centerline of simple support by standard hook.

$M_n$  = is the nominal flexural strength of cross section (without the  $\phi$  factor).  $M_n$  is calculated assuming all reinforcement at the section to be stressed to  $f_y$ .  $M_n$  is not the applied factored moment.

$V_u$  = is shear force calculated at the section.  $l_a$  = At support, shall be the embedded length beyond center of support

$l_a$  = At point of inflection, shall be limited to  $d$  or 12 bar diameters, whichever is greater.

An increase of 30% in the value of  $M_n/V_u$  shall be permitted when the ends of the bars are confined by a compressive reaction such as provided by a column below, but not when a beam frames into a girder (Fig. 7.6a).

---

#### Example 7.4

A continuous beam has the bar details shown in Fig. 7.7. The bending moments for maximum positive and negative moments are also shown. We must check the development lengths at all critical sections. Given:  $f'_c = 3$  ksi normal-weight concrete,  $f_y = 40$  ksi,  $b = 12$  in.,  $d = 18$  in., and span  $L = 24$  ft.

#### Solution

The critical sections are section 1 at the face of the support for tension and compression reinforcement; sections 2 and 5 at points where tension bars are terminated within span; sections 3 and 6 at point of inflection, and at midspan section 4.

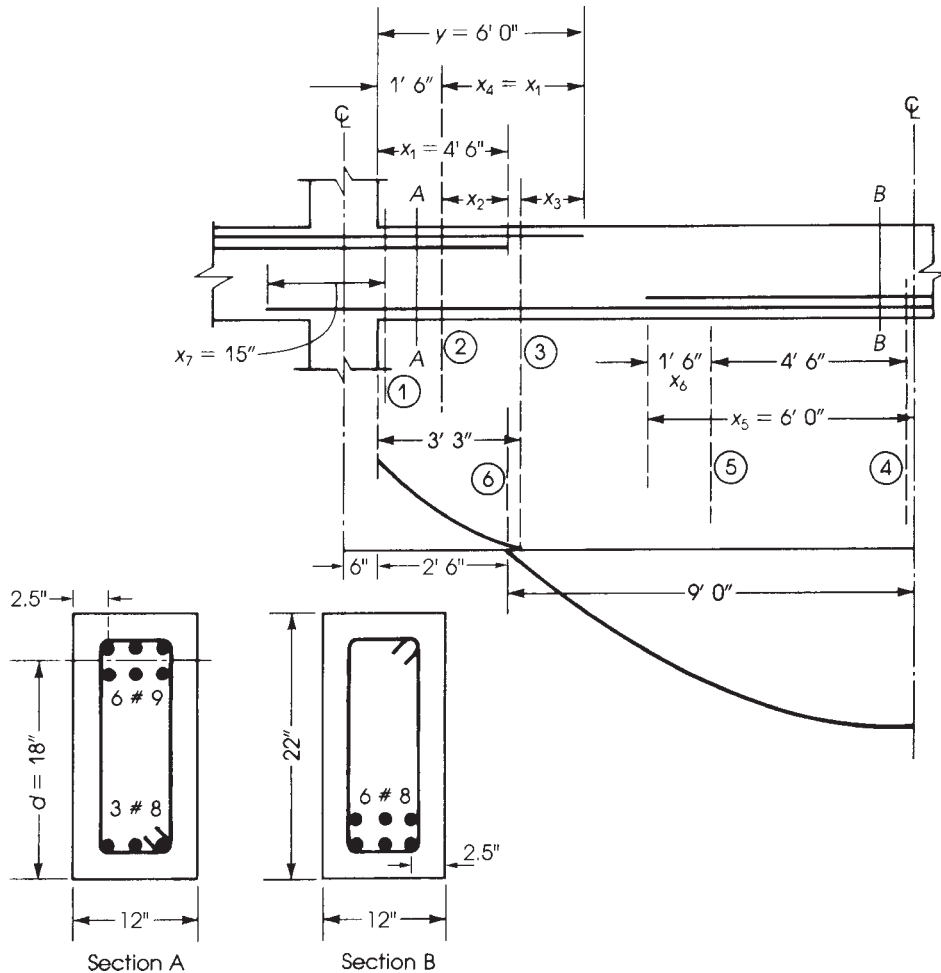


Figure 7.7 Development length of a continuous beam.

1. Development lengths for negative-moment reinforcement, from Fig. 7.7, are as follows: Three no. 9 bars are terminated at a distance  $x_1 = 4.5$  ft from the face of the support, whereas the other three bars extend to a distance of 6 ft (72 in.) from the face of the support.

- a. The development length of no. 9 tension bars if conditions of spacing and cover are satisfied can be determined from Table 7.1 or Eq. 7.11. For no. 9 bars,

$$d_b = 1.128 \text{ in.}$$

$$\text{Clear cover} = 2.5 - \frac{1.128}{2} = 1.94 \text{ in.} > d_b$$

$$\text{Clear spacing} = \frac{12 - 5}{2} - 1.128 = 2.37 \text{ in.} > 2d_b$$

Then conditions are met. Use Table 7.1 to determine  $l_d = 36.6(1.128) = 41.3$  in.  $\psi_t = 1.3$ ,  $\psi_s = 1.0$ . Therefore  $l_d = 1.3(41.3) = 54$  in. For top bars,  $x_1 \geq l_d \geq 12$  in. (minimum).

- b. The development length  $x_2$  shall extend beyond the cutoff point where three no. 9 bars are not needed, either  $d = 18$  in. or  $12d_b = 13.6$  in., whichever is greater. Thus,  $x_2 = 18$  in. The required

development length  $x_4 = 4.50$  ft, is similar to  $x_1$ . Total length required from the face of support for the extended bar is  $y = x_1 + 1.5$  ft = 6.0 ft.

- c. Beyond the point of inflection (section 3), three no. 9 bars extend a length  $x_3 = y - 39 = 72 - 39 = 33$  in. The ACI Code requires that at least one-third of the bars should extend beyond the inflection point. Three no. 9 bars are provided, which are adequate. The required development length of  $x_3$  is the larger of  $d = 18$  in.,  $12d_b = 13.6$  in., or  $L/16 = 24 \times \frac{12}{16}$  in. = 18 in., which is less than the provided  $x_3$  distance.
2. Compressive reinforcement at the face of the support (section 1) (no. 8 bars): The development length  $x_7$  is equal to

$$l_{dc} = \frac{0.02d_b f_y}{\lambda \sqrt{f'_c}} = \frac{0.02 \times 1 \times 40,000}{1 \times \sqrt{3000}} = 14.6 \text{ in.}, \text{ say } 15 \text{ in.}$$

$$\text{Minimum } l_{dc} = 0.0003d_b f_y = 0.0003 \times 1 \times 40,000 = 12 \text{ in.}$$

$l_{dc}$  cannot be less than 8 in. The length 15 in. controls. For no. 8 bars,  $d_b = 1$  in.;  $l_{dc}$  provided = 15 in., which is greater than that required.

3. Development length for positive-moment reinforcement: six no. 8 bars extend 6 ft beyond the centerline, and the three bars extend to the support. The development length  $x_5$  from the centerline is  $l_d = 36.6d_b = 37$  in. (Table 7.1), but it cannot be less than 12 in. That is,  $x_5$  provided is 6 ft = 72 in. > 37 in.

The length  $x_6$  is equal to  $d$  or  $12d_b$ , that is, 18 in. or  $12 \times 1 = 12$  in. The provided value is 18 in., which is adequate.

The actual position of the termination of bars within the span can be determined by the moment-resistance diagram, as will be explained later.

## 7.7 STANDARD HOOKS (ACI CODE, SECTIONS 25.3 AND 25.4)

A *hook* is used at the end of a bar when its straight embedment length is less than the necessary development length,  $l_d$ . Thus, the full capacity of the bar can be maintained in the shortest distance of embedment. The minimum diameter of bend, measured on the inside of the main bar of a standard hook  $D_b$ , is as follows (Fig. 7.8) [9]:

- For no. 3 to no. 8 bars (10–25 mm),  $D_b = 6d_b$ .
- For no. 9 to no. 11 bars (28, 32, and 36 mm),  $D_b = 8d_b$ .
- For no. 14 and no. 18 bars (43 and 58 mm),  $D_b = 10d_b$ .

The ACI Code, Section 25.4.3, specifies a development length  $l_{dh}$  for hooked bar as follows:

$$l_{dh} = \left( \frac{0.02\psi_e f_y}{\lambda \sqrt{f'_c}} \right) (d_b) (\text{modification factor}) \quad (7.15)$$

where

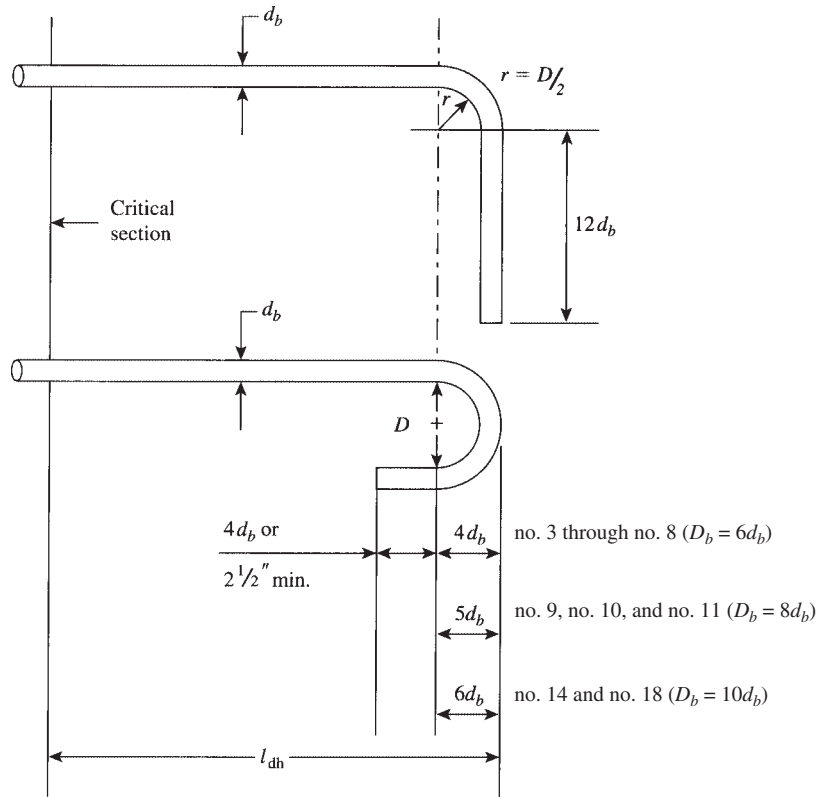
$\psi_e = 1.2$  for epoxy-coated bars

$\lambda = 0.75$  for lightweight aggregate concrete unless  $f_{ct}$  is specified, then  $\lambda = f_{ct}/(6.7(\sqrt{f'_c})) \leq 1$

$\psi_e, \lambda = 1.0$  for all other cases

For grade 60 hooked bar ( $f_y = 60$  ksi) with  $\psi_e = \lambda = 1$ ,  $l_{dh}$  becomes

$$l_{dh} = \frac{1200d_b}{\sqrt{f'_c}} (\text{modification factor}) \quad (7.15a)$$



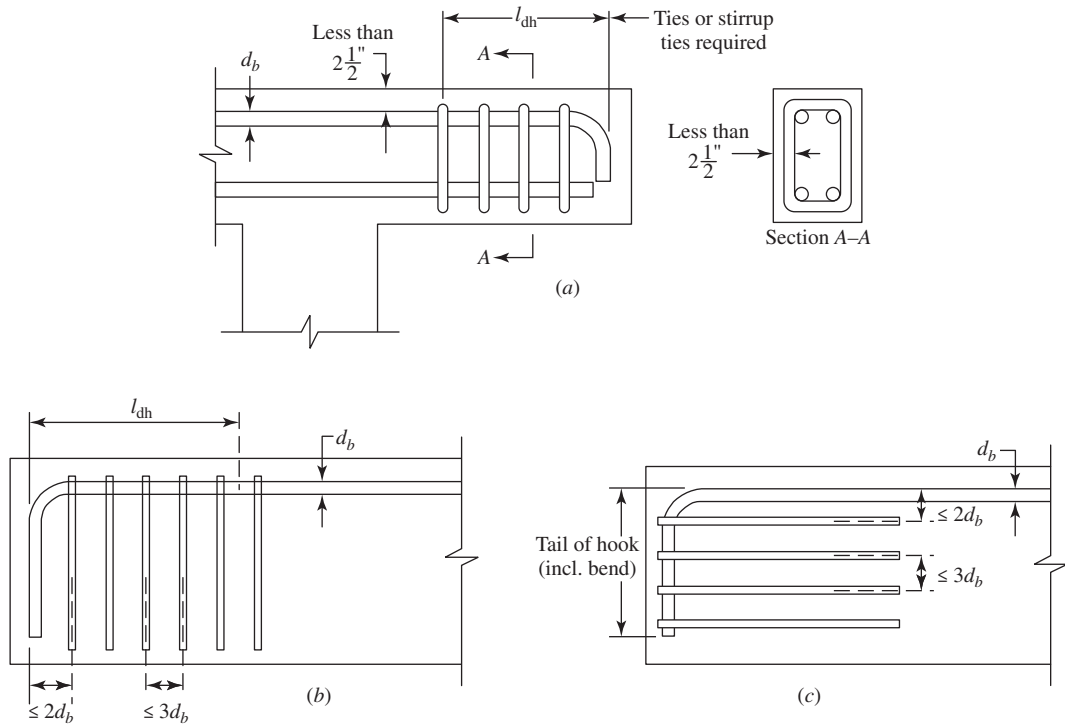
**Figure 7.8** Hooked-bar details for the development of standard hooks [9]. Courtesy of ACI.

Based on different conditions, the development length,  $l_{dh}$ , must be multiplied by one of the following applicable factors:

1. For  $90^\circ$  hooks of no. 11 or smaller bars are used, and the hook is enclosed vertically along  $l_{dh}$  or horizontally along the length of tail extension of the hook plus bend within stirrups or ties spaced not greater than three times the diameter of the hooked bar, the basic development length is multiplied by 0.8. (Figs. 7.9b,c).
2. When no. 11 or smaller bars are used and the side concrete cover, normal to the plane of the hook, is not less than 2.5 in., the development length is multiplied by 0.7. The same factor applies for a  $90^\circ$  hook when the concrete cover on bar extension beyond the hook is not less than 2 in.
3. For  $180^\circ$  hooks of no. 11 or smaller bars that are enclosed with ties or stirrups perpendicular to the bar and spaced not greater than  $3d_b$ , the development length is multiplied by 0.8.
4. When a bar anchorage is not required, the basic development length for the reinforcement in excess of that required is multiplied by the ratio

$$\frac{A_s(\text{required})}{A_s(\text{provided})}$$

5. When standard hooks with less than a 2.5-in. concrete cover on the side and top or bottom are used at a discontinuous end of a member, the hooks shall be enclosed by ties or stirrups



**Figure 7.9** (a) Concrete cover limitations and (b and c) stirrups or ties placed perpendicular or parallel to the bar being developed [9]. Courtesy of ACI.

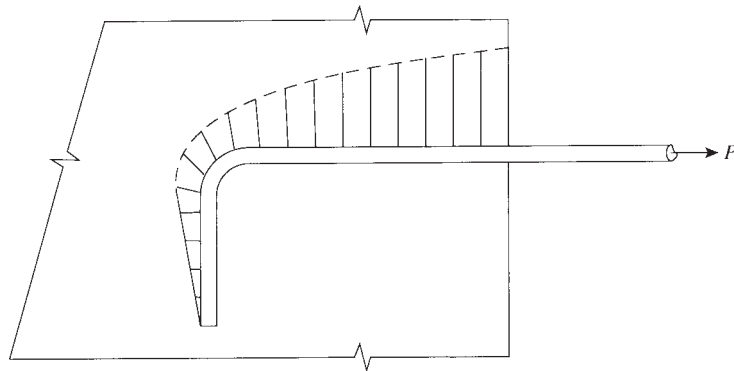
spaced at no greater than  $3d_b$  along  $l_{dh}$ . The first tie or stirrups shall enclose the bent portion of the hook, within  $2d_b$  of the outside of the band. Moreover, the factor 0.8 given in items 1 and 3 shall not be used.

The development length,  $l_{dh}$ , of a standard hook for deformed bars in tension must not be less than  $8d_b$  or 6 in., whichever is greater. Note that hooks are not effective for reinforcing bars in compression and may be *ignored* (ACI Code, Section 25.4.3).

Details of standard  $90^\circ$  and  $180^\circ$  hooks are shown in Fig. 7.8 [9]. The dimensions given are needed to protect members against splitting and spalling of concrete cover. Figure 7.9a shows details of hooks at a discontinuous end with a concrete cover less than 2.5 in. that may produce concrete spalling [9]. The use of closed stirrups is necessary for proper design. Figures 7.9b and c show placement of stirrups or ties perpendicular and parallel to the bar being developed, spaced along the development length. Figure 7.10 shows the stress distribution along a  $90^\circ$  hooked bar under a tension force  $p$ .

The development required for deformed welded wire reinforcement is covered in ACI Code, Section 25.4.6. Development length for welded wire reinforcement in tension  $l_d$ , measured from the critical section to the end of wire, shall be computed as the product of  $l_d$  times welded deformed wire reinforcement factor  $\psi_w$ .

1. For welded deformed wire reinforcement with at least one cross wire within  $l_d$  and not less than 2 in. from the point of critical section,  $\psi_w$  shall be the greater of  $(f_y - 35,000)/f_y$  and  $5d_b/s$  but not greater than 1.0, where  $s$  is the spacing between wires to be developed.



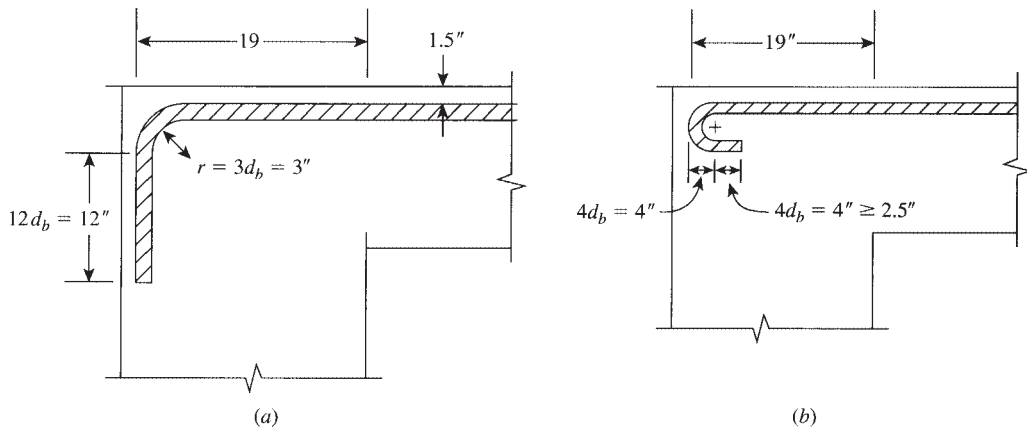
**Figure 7.10** Stress distribution in 90° hooked bar.

2. With no cross wire within  $l_d$  or with a single cross wire less than 2 in. from the point of critical section,  $\psi_w = 1.0$ .

### Example 7.5

Compute the development length required for the top no. 8 bars of the cantilever beam shown in Fig. 7.11 that extend into the column support if the bars are

- Straight
- Have a 90° hook at the end
- Have a 180° hook at the end



**Figure 7.11** Example 7.5.

The bars are confined by no. 3 stirrups spaced at 6 in. and have a clear cover = 1.5 in. and clear spacings = 2.0 in. Use  $f'_c = 4$  ksi normal-weight concrete and  $f_y = 60$  ksi.

### Solution

- Straight bars: For no. 8 bars,  $d_b = 1.0$  in. Because clear spacing =  $2d_b$  and clear cover is greater than  $d_b$  with bars confined by stirrups, then conditions *a* and *b* are met. Equation 7.10 can be used

to calculate the basic  $l_d$  or you can get it directly from Table 7.2:  $l_d = 48$  in. For top bars,  $\psi_e = 1.3$  and final  $l_d = 1.3(48) = 63$  in.

- b. Bars with  $90^\circ$  hook: For no. 8 bars,  $d_b = 1.0$  in. development length for  $f_y = 60$  ksi  $l_{dh} = 1200d_b/\sqrt{f'_c} = 1200(1.0)/\sqrt{4000} = 19$  in. Because no other modifications apply, then  $l_{dh} = 19$  in.  $> 8d_b = 8$  in. or 6 in. Other details are shown in Fig. 7.11. The factor  $\psi_e = 1.3$  for top bars does not apply to hooks.
- c. Bars with  $180^\circ$  hook:  $l_{dh} = 19$  in., as calculated before. No other modifications apply; then  $l_{dh} = 19$  in.  $> 8d_b = 8$  in. Other details are shown in Fig. 7.11.

## 7.8 SPLICES OF REINFORCEMENT

### 7.8.1 General

Steel bars that are used as reinforcement in structural members are fabricated in lengths of 20, 40, and 60 ft (6, 12, and 18 m), depending on the bar diameter, transportation facilities, and other reasons. Bars are usually tailored according to the reinforcement details of the structural members. When some bars are short, it is necessary to splice them by lapping the bars a sufficient distance to transfer stress through the bond from one bar to the other.

ACI Code, Section 25.6.1.7, gives the provisions for lap splicing of bars in a bundle (tension or compression). The lap-splice length required for individual bars within a bundle must be increased 20% for a 3-bar bundle and 33% for a 4-bar bundle. Overlapping of individual bar splices with a bundle is not permitted. Two bundles must not be lap spliced as individual bars. For noncontact lap splices in flexural members, bars should not be spaced transversely farther apart than one-fifth the required length or 6 in. (150 mm).

ACI Code, Section 25.5.7, permits the use of mechanical and welded splices. A full mechanical splice must develop, in tension or compression, at least 125% of the  $f_y$  of bar (ACI Code, Section 25.5.7.1).

In a full welded splice, the bars must develop in tension at least 125% of the specified yield strength of bar (ACI Code, Section 25.5.7.1).

ANSI/AWSD1.4 allows indirect welds where the bars are not butted. Although AWSD1.4 does indicate that, wherever practical, direct butt splices are preferable for no.7 bars and larger.

Use of mechanical and welded splices have less than 125% of the specified yield strength of bars in the region of low computed stresses.

Splices should not be made at or near sections of maximum moments or stresses. Also, it is recommended that no bars should be spliced at the same location to avoid a weakness in the concrete section and to avoid the congestion of bars at the same location, which may cause difficulty in placing the concrete around the bars.

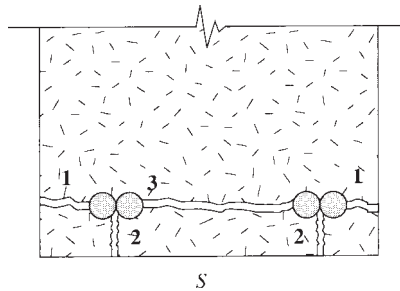
The stresses developed at the end of a typical lap splice are equal to 0, whereas the lap-splice length,  $l_d$ , embedded in concrete is needed to develop the full stress in the bar,  $f_y$ . Therefore, a minimum lap splice of  $l_d$  is needed to develop a continuity in the spliced tension or compression bars. If adequate splice length is not provided, splitting and spalling occurs in the concrete shell (Fig. 7.12).

Splices in tension and compression are covered by Sections 25.5 of the ACI Code.

### 7.8.2 Lap Splices in Tension, $l_{st}$

Depending upon the percentage of bars spliced on the same location and the level of stress in the bars or deformed wires, the ACI Code introduces two classes of splices (with a minimum splice length of 12 in.):





**Figure 7.12** Lap-splice failure due to the development of one or more cracks.

1. Class A splices: These splices have a minimum length  $l_{st} = l_d$  and are used when (a) one-half or less of the total reinforcement is spliced within the required lap-splice length; and (b) the area of tensile reinforcement provided is at least twice that required by analysis over the entire length of the splice. The length  $l_d$  is the development length of the bar, as calculated earlier.
2. Class B splices: These splices have a minimum length  $l_{st} = 1.3l_d$  and are used for all other cases that are different from the aforementioned conditions. For example, class B splices are required when all bars or deformed wires are spliced at the same location with any ratio of  $(A_s \text{ provided})/(A_s \text{ required})$ . Splicing all the bars in one location should be avoided when possible.
3.  $l_d$  in classes A and B splices is calculated without the modification factor of  $(A_s \text{ required})/(A_s \text{ provided})$ .
4. When multiple bars located in the same plane are spliced at the same section, the clear spacing is the minimum clear distance between the adjacent splices. For staggered splices, the clear spacing is taken as the minimum distance between adjacent splices.
5. When bars of different size are lap spliced in tension, splice length shall be the larger of  $l_d$  of the larger bar and the tension lap-splice length of the smaller bar (ACI Code, Section 25.5.2.2).
6. Lap splice shall not be used for bars larger than no. 11 because of lack of adequate experimental data (ACI Code, Section 25.5.1.1).

### 7.8.3 Lap Splice in Compression, $l_{sc}$

The lap-splice length of the reinforcing bars in compression,  $l_{sc}$ , should be equal to or greater than the development length of the bar in compression,  $l_{dc}$  (including the modifiers), calculated earlier (Eq. 7.14). Moreover, the lap-splice length shall satisfy the following (ACI Code, Section 25.5.5.1):

$$l_{sc} = (0.0005f_y d_b) \quad \text{for } f_y \leq 60,000 \text{ psi} \quad (7.16)$$

$$l_{sc} = (0.0009f_y - 24)d_b \quad \text{for } f_y > 60,000 \text{ psi} \quad (7.17)$$

For both cases, the lap-splice length must not be less than 12 in. Table 7.5 gives the lap-splice length for various  $f_y$  values. If the concrete strength,  $f'_c$ , is less than 3000 psi, the lap-splice length,  $l_{sc}$ , must be increased by one-third. When bars of different sizes are lap spliced in compression, splice length shall be the larger of  $l_{dc}$  of larger bar and compression lap splice  $l_{sc}$  of smaller bar. Lap splices of no. 14 and no.18 to no. 11 and smaller shall be permitted.

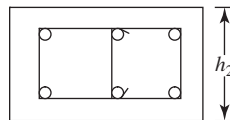
**Table 7.5** Lap-Splice Length in Compression,  $l_{sc}$  (in.), ( $f'_c \geq 3$  ksi and Minimum  $l_{sc} = 12$  in.)

Bar Number	Bar Diameter (in.)	$f_y$ (ksi)		
		40	60	80
3	0.375	12	12	18
4	0.500	12	15	24
5	0.625	13	19	30
6	0.750	15	23	36
7	0.875	18	27	42
8	1.000	20	30	48
9	1.128	23	34	55
10	1.270	26	39	61
11	1.410	29	43	68

### 7.8.4 Lap Splice in Columns

The following special requirements are given in ACI Code, Section 10.7.5, for lap splice in columns:

- If bar stress due to factored load is tensile and does not exceed  $0.5f_y$  in tension ( $\leq 0.5f_y$ ), use class B tension splice if more than one-half of total column bars spliced at same location, or use class A splice if not more than one-half of total column bar spliced at same location and alternate lap splices are staggered by  $l_d$ .
- If bar stress due to factored loads  $> 0.5f_y$  in tension, use class B lap splice.
- In spirally reinforced columns, lap-splice length within a spiral may be multiplied by 0.75 but may not be less than 12 in. In tied columns, with ties within the splice length having a minimum effective area of  $0.0015hs$ , lap splice may be multiplied by 0.83 but may not be less than 12 in., where  $h$  is overall thickness of column and  $s$  is spacing of ties (in.). Tie legs parallel to dimension  $h$  shall be used in determining effective area.



$\leftarrow h_1 \rightarrow$   
 (Parallel to  $h_1$  dimension)  
 = 3 tie bar areas  $\geq 0.0015h_1s$   
 (Parallel to  $h_2$  dimension)  
 = 2 tie bar areas  $\geq 0.0015h_1s$

### Example 7.6

Calculate the lap-splice length for six no. 8 tension bottom bars (in two rows) with clear spacing = 2.5 in. and clear cover = 1.5 in. for the following cases:

- When three bars are spliced and  $(A_s \text{ provided}) / (A_s \text{ required}) > 2$ .
- When four bars are spliced and  $(A_s \text{ provided}) / (A_s \text{ required}) < 2$ .
- When all bars are spliced at the same location. Given:  $f'_c = 5$  ksi and  $f_y = 60$  ksi.

**Solution**

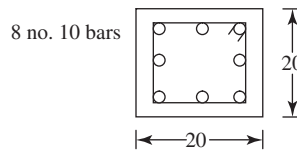
- a. For no. 8 bars,  $d_b = 1.0$  in., and  $\psi_t = \psi_e = \lambda = 1.0$ : Check first for  $\sqrt{5000} = 70.7$  psi  $< 100$  psi, and then calculate  $l_d$  from Eq. 7.8 or Table 7.1,  $l_d = 42.5d_b$ , conditions for clear spacings and cover are met.  $l_d = 42.5(1.0) = 42.5$  in., or 43 in. For  $(A_s \text{ provided})/(A_s \text{ required}) > 2$ , class A splice applies,  $l_{st} = 1.0l_d = 43$  in.  $> 12$  in. (minimum). Bars spliced are less than half the total number.
- b. Let  $l_d = 43$  in., as calculated before. Because  $(A_s \text{ provided})/(A_s \text{ required})$  is less than 2, class B splice applies,  $l_{st} = 1.3l_d = 1.3(42.5) = 55.25$  in., say, 56 in., which is greater than 12 in. and more than half the total number of bar spliced.
- c. Class B splice applies and  $l_{st} = 56$  in.  $> 12$  in.

**Example 7.7**

Calculate the lap-splice length for a tied column. The column has eight no. 10 longitudinal bars and no. 3 ties. Given  $f'_c = 5$  ksi, solve for (a)  $f_y = 60$  ksi and (b)  $f_y = 80$  ksi.

**Solution**

Tie spacing  $s$  is the smaller of  $16 \times 1.128 = 18$  in.,  $48 \times 3/8 = 18$  in. or 20 in. therefore  $s = 18$  in.



- a. Determine lap-splice length for  $f_y = 60,000$  psi

$$\begin{aligned}
 l_{sc} &= 0.0005f_y d_b > 12 \text{ in.} \\
 &= 0.0005 \times 60,000 \times 1.27 \\
 &= 38.1 \text{ in.} \approx 39 \text{ in.} > 12 \text{ in.}
 \end{aligned}
 \tag{Eq. 7.16}$$

Determine column tie requirements to allow 0.83 reduce lap-splice length according to ACI Code, Section 10.7.5.2.1.

Effective area of ties  $\geq 0.0015 h s$

$$\begin{aligned}
 2 \times 0.11 &\geq 0.0015 \times 20 \times 18 \\
 0.22 &< 0.54
 \end{aligned}$$

Modifier 0.83 will not apply. Lap-splice length = 39 in.

- b. Determine lap-splice length for  $f_y > 60,000$  psi

$$\begin{aligned}
 l_{sc} &= (0.0009f_y - 24)d_b \\
 &= (0.0009 \times 80,000 - 24) \times 1.27 \\
 &= 60.96 \text{ in.} \approx 61 \text{ in.}
 \end{aligned}
 \tag{Eq. 7.17}$$

Modifier 0.83 will not apply as previously calculated.

**Example 7.8**

Calculate the lap-splice length for  $20 \times 20$ -in. tied column, for the following cases:

Load combination 1: All bars are in compression.

Load combination 2: Bar stress  $< 0.5f_y$

Load combination 3: Bar stress  $> 0.5f_y$

Given  $f'_c = 4$  ksi,  $f_y = 60$  ksi, cover to the stirrups edge = 1.5 in.

Provided 4 no. 10 bars (above and below floor level)

No. 3 ties at 18 in.

**Solution:**

1. Determine type of lap splice required:

For load combination 1. All bars are in compression, so a compression lap splice could be used (ACI Code, Section 10.7.5.2.1).

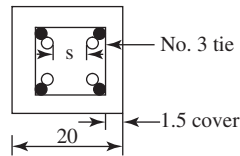
For load combination 2. Bar stress  $< 0.5f_y$ , so a class B tension splice required of more than half of bars spliced at section or a class A splice may be used if alternate lap splice are staggered (ACI Code, Section 10.7.5.2.2).

For load combination 3. Bar stress  $> 0.5f_y$ , class B splice must be used (ACI Code, Section 10.7.5.2.2).

Lap splice required for the four no. 10 bars must be based on the load combination producing the greatest amount of tension in the bars.

For this example load combination 3 governs.

2. Determine lap-splice length:



Nominal diameter of no. 10 bar = 1.27 in.

Clear spacing between bars being developed is large and will not govern.

Clear cover =  $1.5 + 0.375 = 1.875 > d_b = 1.27$ .

Distance from center of bar to concrete surface =  $1.875 + 0.635 = 2.51 > d_b$ .

$c_b$  is the smaller of (1) distance from center of bar being developed to the nearest concrete surface.

(2) One-half the center-to-center spacing of bars being developed.

$$c_b = 2.51$$

$$l_d = \left[ \frac{3}{40} \frac{f_y}{\lambda \sqrt{f'_c}} \frac{\psi_t \psi_e \psi_s}{(c_b + k_{tr}) / d_b} \right] d_b$$

$$\psi_t = 1.0 \text{ for vertical bar}$$

$$\psi_c = 1.0 \text{ for uncoated bar}$$

$$\psi_s = 1.0 \text{ for no. 7 and larger bars}$$

$$\lambda = 1.0 \text{ for normal - weight concrete}$$

$$k_{tr} = \frac{40A_{tr}}{sn} = \frac{40 \times 2 \times (0.11)}{18 \times 2} = 0.244$$

$$\frac{c_b + k_{tr}}{d_b} = \frac{2.51 + 0.244}{1.27} = 2.16 < 2.5, \text{ use } 2.16$$

$$l_d = \left( \frac{3}{40} \right) \frac{(60,000)(1.0)(1.0)(1.0)}{(1)\sqrt{4000}(2.16)}(1.28) = 41.8 \text{ in.}$$

$$\text{Class B splice} = 1.3(32.83) = 54.3 \text{ in.}$$

## 7.9 MOMENT–RESISTANCE DIAGRAM (BAR CUTOFF POINTS)

The moment capacity of a beam is a function of its effective depth,  $d$ , width,  $b$ , and the steel area for given strengths of concrete and steel. For a given beam, with constant width and depth, the amount of reinforcement can be varied according to the variation of the bending moment along the span. It is a common practice to cut off the steel bars where they are no longer needed to resist the flexural stresses. In some other cases, as in continuous beams, positive-moment steel bars may be bent up, usually at  $45^\circ$ , to provide tensile reinforcement for the negative moments over the supports.

The factored moment capacity of an underreinforced concrete beam at any section is

$$M_u = \phi A_s f_y \left( d - \frac{a}{2} \right) \quad (7.18)$$

The lever arm  $(d - a/2)$  varies for sections along the span as the amount of reinforcement varies; however, the variation in the lever arm along the beam length is small and is never less than the value obtained at the section of maximum bending moment. Thus, it may be assumed that the moment capacity of any section is proportional to the tensile force or the area of the steel reinforcement, assuming proper anchorage lengths are provided.

To determine the position of the cutoff or bent points, the moment diagram due to external loading is drawn first. A moment–resistance diagram is also drawn on the same graph, indicating points where some of the steel bars are no longer required. The factored moment resistance of one bar,  $M_{ub}$ , is

$$M_{ub} = \phi A_{sb} f_y \left( d - \frac{a}{2} \right) \quad (7.19)$$

where

$$a = \frac{A_s f_y}{0.85 f'_c b}$$

$A_{sb}$  = area of one bar

The intersection of the moment–resistance lines with the external bending moment diagram indicates the theoretical points where each bar can be terminated. To illustrate this discussion, Fig. 7.13 shows a uniformly loaded simple beam, its cross section, and the bending moment diagram. The bending moment curve is a parabola with a maximum moment at midspan of  $2400 \text{ K} \cdot \text{in}$ . Because the beam is reinforced with four no. 8 bars, the factored moment resistance of one bar is

$$M_{ub} = \phi A_{sb} f_y \left( d - \frac{a}{2} \right)$$

$$a = \frac{A_s f_y}{0.85 f'_c b} = \frac{4 \times 0.79 \times 50}{0.85 \times 3 \times 12} = 5.2 \text{ in.}$$

$$M_{ub} = 0.9 \times 0.79 \times 50 \left( 20 - \frac{5.2}{2} \right) = 620 \text{ K} \cdot \text{in.}$$

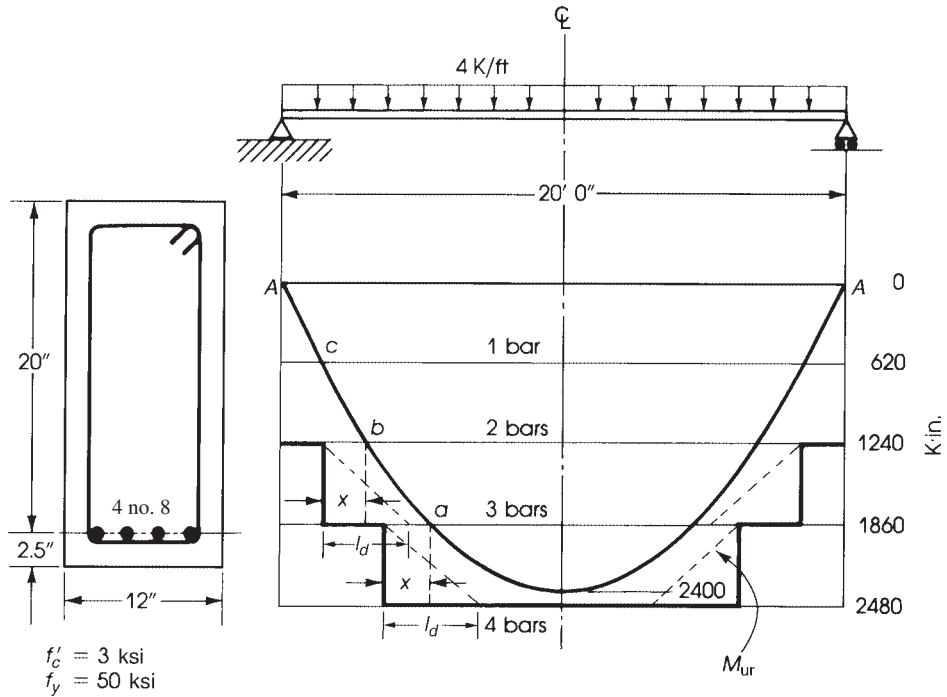
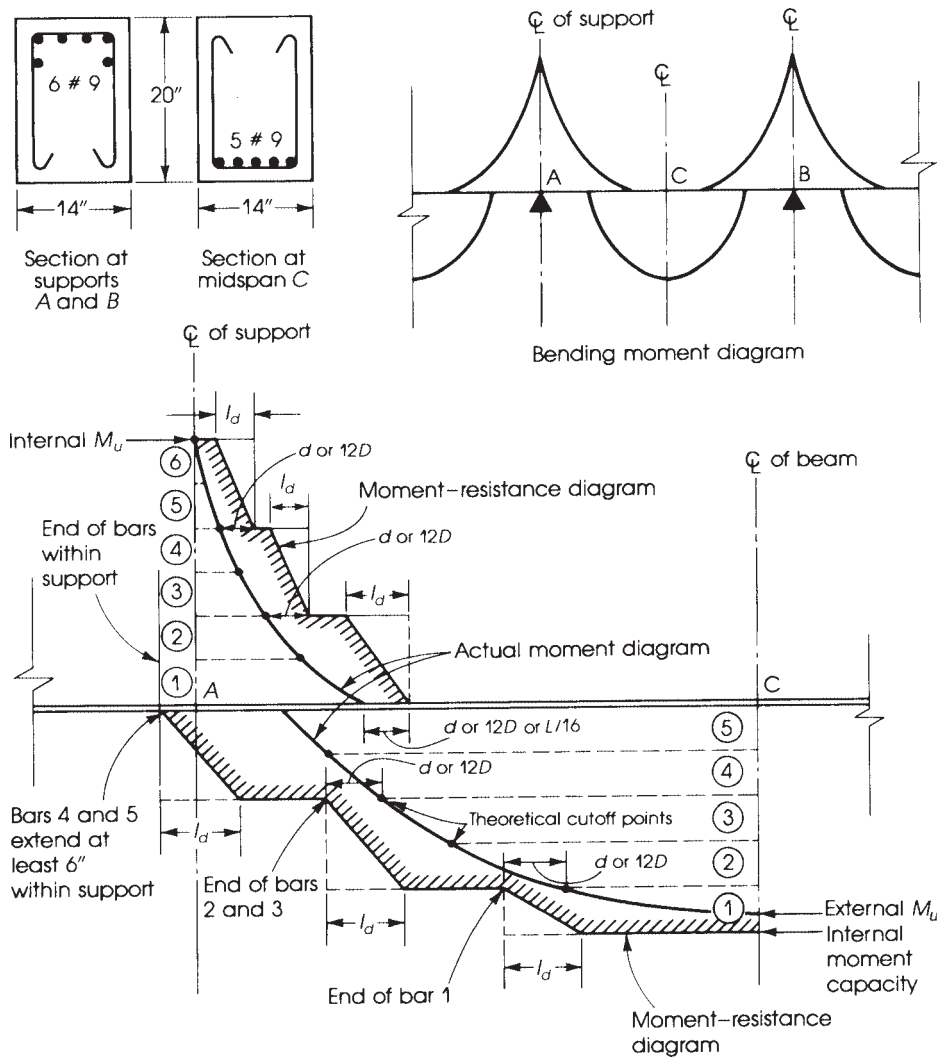


Figure 7.13 Moment-resistance diagram.

The factored moment-resistance of four bars is thus 2480 K·in., which is greater than the external moment of 2400 K·in. If the moment diagram is drawn to scale on the baseline A–A, it can be seen that one bar can be terminated at point  $a$ , a second bar at point  $b$ , the third bar at point  $c$ , and the fourth bar at the support end A. These points are the theoretical positions for the termination of the bars. However, it is necessary to develop part of the strength of the bar by bond, as explained earlier. The ACI Code specifies that every bar should be continued at least a distance equal to the effective depth,  $d$ , of the beam or 12 bar diameters, whichever is greater, beyond the theoretical points  $a$ ,  $b$ , and  $c$ . The Code (Section 9.7.3.8) also specifies that at least one-third of the positive-moment reinforcement must be continued to the support for simple beams. Therefore, for the example discussed here, two bars must extend into the support, and the moment-resistance diagram,  $M_{ur}$ , shown in Fig. 7.13, must enclose the external bending moment diagram at all points. Full load capacity of each bar is attained at a distance  $l_d$  from its end.

For continuous beams, the bars are bent at the required points and used to resist the negative moments at the supports. At least one-third of the total reinforcement provided for the negative moment at the support must be extended beyond the inflection points a distance not less than the effective depth, 12 bar diameters, or  $\frac{1}{16}$  the clear span, whichever is greatest (ACI Code, Sections 7.7.3.8 and 9.7.3.8).

Bent bars are also used to resist part of the shear stresses in beams. The moment-resistance diagram for a typical continuous beam is shown in Fig. 7.14.



**Figure 7.14** Sections and bending moment diagram (*top*) and moment–resistance diagram (*bottom*) of a continuous beam. Bar diameter is signified by  $D$ .

### Example 7.9

For the simply supported beam shown in Fig. 7.15, design the beam for the given factored loads and draw the moment–resistance diagram. Also, show where the reinforcing bars can be terminated. Use  $b = 10$  in., a steel ratio of 0.018,  $f'_c = 3$  ksi, and  $f_y = 40$  ksi.

### Solution

For  $\rho = 0.018$ ,  $R_u = 556$  psi and  $M_u = R_u b d^2$ . Let  $M_u = 132.5$  K · ft. Now  $132.5(12) = 0.556(10)d^2$ , so  $d = 17$  in.; let  $h = 20$  in.

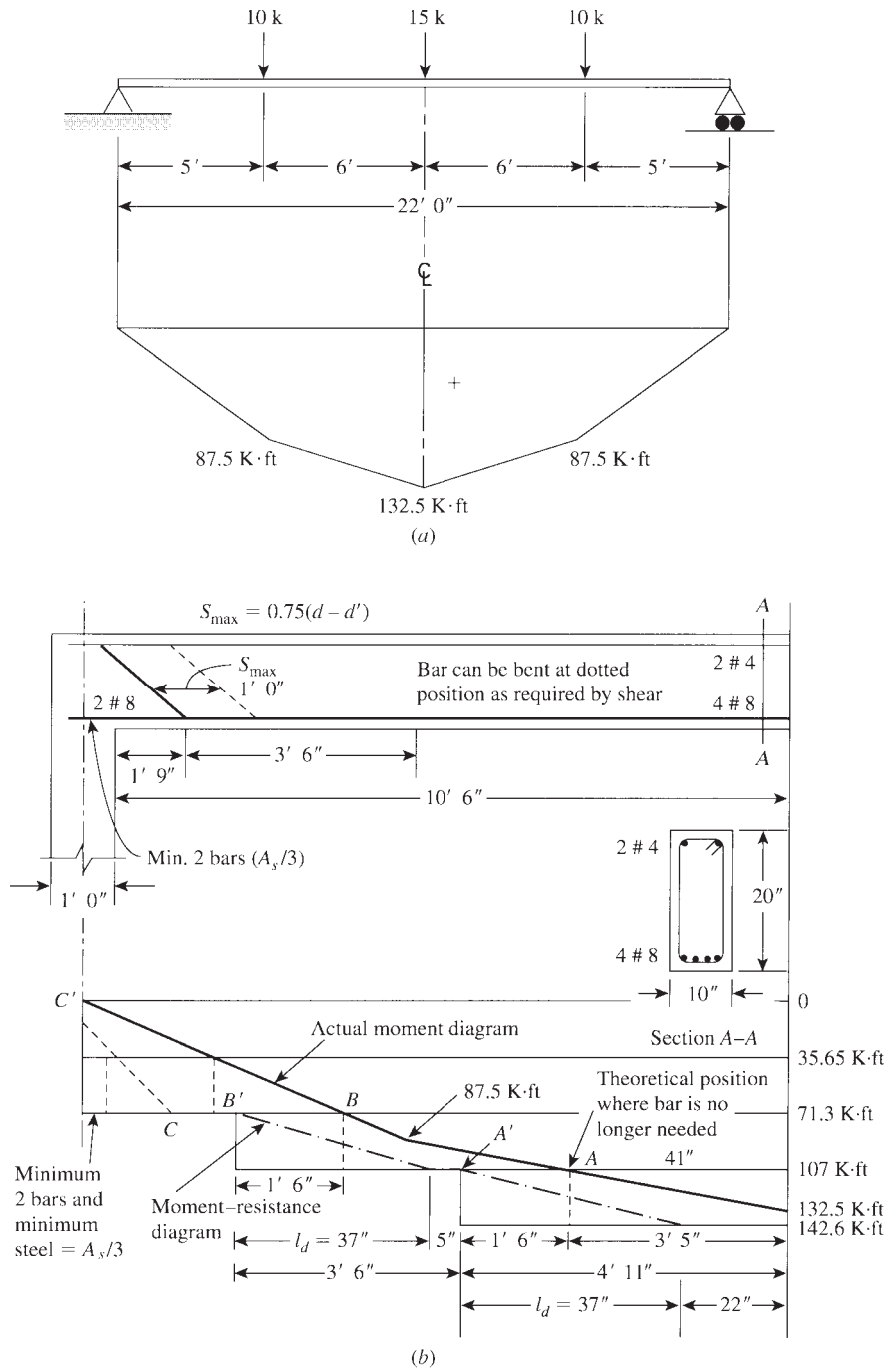


Figure 7.15 Details of reinforcing bars and the moment-resistance diagram.



Let  $A_s = 0.018(10)(17) = 3.06 \text{ in.}^2$ ; use four no. 8 bars ( $A_s = 3.14 \text{ in.}^2$ ). Actual  $d = 20 - 2.5 = 17.5 \text{ in.}$

$$M_{ur} = \phi A_s f_y \left( d - \frac{a}{2} \right) \quad \text{and} \quad a = \frac{3.14(40)}{0.85(3)(10)} = 4.93 \text{ in.}$$

$$\begin{aligned} M_{ur}(\text{for one bar}) &= 0.9(0.79)(40) \left( 17.5 - \frac{4.93}{2} \right) \\ &= 427.7 \text{ K} \cdot \text{in.} = 35.64 \text{ K} \cdot \text{ft} \end{aligned}$$

$$M_{ur}(\text{for all four bars}) = 1710.8 \text{ K} \cdot \text{in.} = 142.6 \text{ K} \cdot \text{ft}$$

For the calculation of 'a', the four no. 8 bars were utilized rather than calculating the 'a' for the extended two bars. This assumption will slightly increase the length of the bars beyond the cutoff point.

Details of the moment–resistance diagram are shown in Fig. 7.15. Note that the bars can be bent or terminated at a distance of 17.5, say, 18 in. (or 12 bar diameters, whichever is greater), beyond the points where (theoretically) the bars are not needed. The development length,  $l_d$ , for no. 8 bars is  $36.6d_b = 37 \text{ in.}$  (Table 7.1). The cutoff points of the first and second bars are at points A and B, but the actual points are at A' and B', 18 in. beyond A and B. From A', a length  $l_d = 37 \text{ in.}$  backward is shown to establish the moment–resistance diagram (the dashed line). The end of the last two bars extending to the support will depend on how far they extend inside the support, say, at C'. Normally, bars are terminated within the span at A' and B' as bent bars are not commonly used to resist shear.

## SUMMARY

### Sections 7.1 and 7.2

Bond is influenced mainly by the roughness of the steel surface area, the concrete mix, shrinkage, and the cover of concrete. In general,

$$l_d = \frac{A_s f_y}{U_u \sum O} \quad (\text{Eq. 7.3})$$

### Sections 7.3 and 7.5

1. The general formula for the development length of deformed bars or wire shall be

$$\frac{l_d}{d_b} = \left( \frac{3}{40\lambda} \right) \left( \frac{f_y}{\sqrt{f'_c}} \right) \left( \frac{\psi_t \psi_e \psi_s}{(c_b + k_{tr}) / d_b} \right) \quad (\text{Eq. 7.7})$$

As design simplification,  $k_{tr}$  may be assumed to be zero. Other values of  $l_d/d_b$  are given in Tables 7.1 and 7.2.  $\psi_t$ ,  $\psi_e$ ,  $\psi_s$ , and  $\lambda$  are multipliers defined in Section 7.3.1.

2. Simplified expressions are used when conditions for concrete cover and spacing requirement are met. For no. 7 and larger bars,

$$\frac{l_d}{d_b} = \left( \frac{f_y}{\sqrt{f'_c}} \right) \left( \frac{\psi_t \psi_e}{20\lambda} \right) = Q$$

For no. 6 and smaller bars,

$$\frac{l_d}{d_b} = 0.8Q$$

3. For all other cases, multiply the previous  $Q$  by 1.5.
4. Minimum length is 12 in.

**Section 7.4**

Development length in compression for all bars is

$$l_{dc} = \frac{0.02d_b f_y}{\lambda \sqrt{f'_c}} \geq 0.0003d_b f_y \geq 8\text{in.} \quad (\text{Eq. 7.14})$$

For specific values, refer to Tables 7.3 and 7.4.

**Section 7.6**

The critical sections for the development of reinforcement in flexural members are

- At points of maximum stress
- At points where tension bars are terminated within the span
- At the face of the support
- At points of inflection

**Section 7.7**

The minimum diameter of bends in standard hooks is

- For no. 3 to no. 8 bars,  $6d_b$
- For no. 9 to no. 11 bars,  $8d_b$

The development length  $l_{dh}$  of a standard hook is

$$l_{dh} = \left( \frac{0.02\psi f_y}{\lambda \sqrt{f'_c}} \right) (d_b) (\text{modification factor})$$

**Section 7.8**

1. For splices in tension, the minimum lap-splice length is 12 in. If (a) one-half or less of the total reinforcement is spliced within the required lap-splice length and (b) the area of reinforcement provided is at least twice that required by analysis over the entire length of the splice, then  $l_{st} = 1.0 l_d = \text{class A splice}$ .
2. For all other cases, class B has to be used when  $l_{st} = 1.3l_d$ .
3. For splices in compression, the lap-splice length should be equal to or greater than  $l_{dc}$  in compression, but it also should satisfy the following:  $l_{sc} \geq 0.0005 f_y d_b$  (for  $f_y \leq 60,000$  psi).

**REFERENCES**

1. L. A. Lutz and P. Gergely. "Mechanics of Bond and Slip of Deformed Bars in Concrete." *ACI Journal* 68 (April 1967), pp. 711–721.
2. ACI Committee 408. "Bond Stress—The State of the Art." *ACI Journal* 63 (November 1966).
3. ACI Committee 408. "Opportunities in Bond Research." *ACI Journal* 67 (November 1970).
4. Y. Goto. "Cracks Formed in Concrete around Deformed Tensioned Bars." *ACI Journal* 68 (April 1971).
5. T. D. Mylrea. "Bond and Anchorage." *ACI Journal* 44 (March 1948), pp. 521–552.
6. E. S. Perry and J. N. Thompson. "Bond Stress Distribution on Reinforcing Steel in Beams and Pullout Specimens." *ACI Journal* 63 (August 1966).

7. C. O. Orangum, J. O. Jirsa, and J. E. Breen. "A Reevaluation of Test Data on Development Length and Splices." *ACI Journal* 74 (March 1977).
8. J. Minor and J. O. Jirsa. "Behavior of Bent Bar Anchorage." *ACI Journal* 72 (April 1975).
9. American Concrete Institute Detroit (ACI), ACI Code. Building Code Requirements for Structural Concrete. ACI 318-14. ACI, Detroit, MI, 2014.

## PROBLEMS

- 7.1** For each assigned problem, calculate the development length required for the following tension bars. All bars are bottom bars in normal-weight concrete unless specified otherwise in the notes.

No.	Bar No.	$f'_c$ (ksi)	$f_y$ (ksi)	Clear Cover (in.)	Clear Spacing (in.)	Notes
a	5	3	60	2.0	2.25	
b	6	4	60	2.0	2.50	Lightweight aggregate concrete
c	7	5	60	2.0	2.13	Epoxy coated
d	8	3	40	2.5	2.30	Top bars, lightweight aggregate concrete
e	9	4	60	1.5	1.5	
f	10	5	60	2.0	2.5	No. 3 stirrups at 6 in.
g	11	5	60	3.0	3.0	
h	9	3	40	2.0	1.5	Epoxy coated
i	8	4	60	2.0	1.75	$(A_s \text{ provided})/(A_s \text{ required}) = 1.5$
j	6	4	60	1.5	1.65	Top bars, epoxy coated and no. stirrup at 4 in.

- 7.2** For each assigned problem, calculate the development length required for the following bars in compression.

No.	Bar No.	$f'_c$ (ksi)	$f_y$ (ksi)	Notes
a	8	3	60	
b	9	4	60	
c	10	4	40	
d	11	5	60	$(A_s \text{ required})/(A_s \text{ provided}) = 0.8$
e	7	6	60	$(A_s \text{ required})/(A_s \text{ provided}) = 0.9$
f	9	5	60	Column with spiral no. 3 at 2 in.

- 7.3** Compute the development length required for the top no. 9 bars of a cantilever beam that extend into the column support if the bars are
- a. Straight
  - b. Have a 90° hook at the end
  - c. Have a 180° hook at the end

The bars are confined with no. 3 stirrups spaced at 5 in. and have a clear cover of 2.0 in. Use  $f'_c = 4$  ksi and  $f_y = 60$  ksi. (Clear spacing = 2.5 in.)

- 7.4** Repeat Problem 7.3 when no. 7 bars are used.  
**7.5** Repeat Problem 7.3 when  $f'_c = 3$  ksi and  $f_y = 40$  ksi.  
**7.6** Repeat Problem 7.3 when no. 10 bars are used.

- 7.7 Calculate the lap-splice length for no. 9 tension bottom bars with clear spacing of 2.0 in. and clear cover of 2.0 in. for the following cases:
- When 50% of the reinforcement is spliced and  $(A_s \text{ provided})/(A_s \text{ required}) = 2$ .
  - When 75% of the reinforcement is spliced and  $(A_s \text{ provided})/(A_s \text{ required}) = 1.5$ .
  - When all bars are spliced at one location and  $(A_s \text{ provided})/(A_s \text{ required}) = 2$ .
  - When all bars are spliced at one location and  $(A_s \text{ provided})/(A_s \text{ required}) = 1.3$ . Use  $f'_c = 4$  ksi and  $f_y = 60$  ksi.
- 7.8 Repeat Problem 7.7 using  $f'_c = 3$  ksi and  $f_y = 60$  ksi.
- 7.9 Calculate the lap splice length for no. 9 bars in compression when  $f'_c = 5$  ksi and  $f_y = 60$  ksi.
- 7.10 Repeat Problem 7.9 when no. 11 bars are used.
- 7.11 Repeat Problem 7.9 when  $f_y = 80$  ksi.
- 7.12 Repeat Problem 7.9 when  $f'_c = 4$  ksi and  $f_y = 60$  ksi.
- 7.13 A continuous beam has the typical steel reinforcement details shown in Fig. 7.16. The sections at midspan and at the face of the support of a typical interior span are also shown. Check the development lengths of the reinforcing bars at all critical sections. Use  $f'_c = 4$  ksi and  $f_y = 60$  ksi.

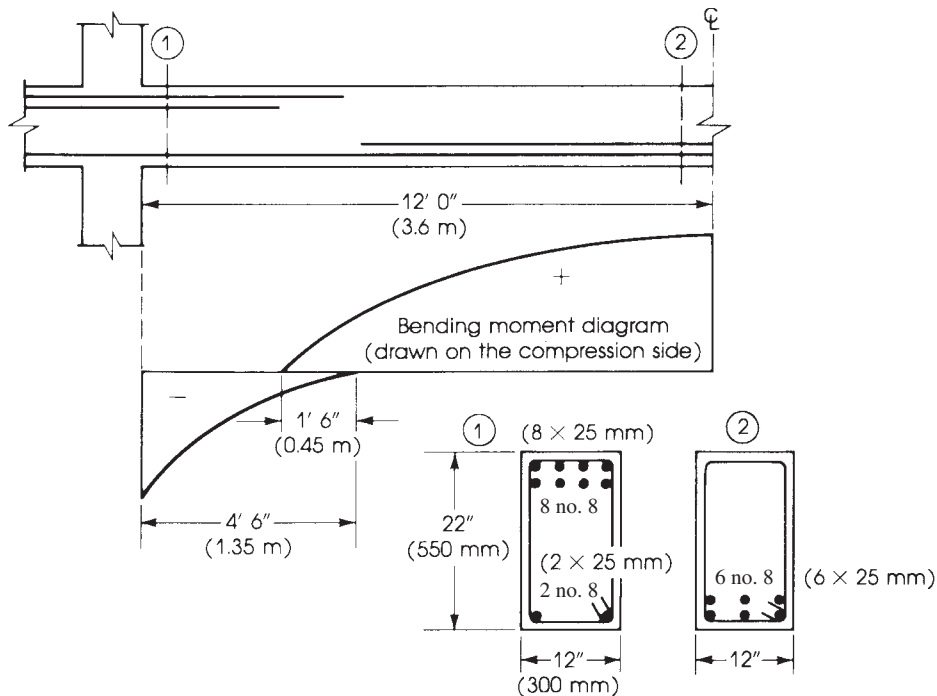
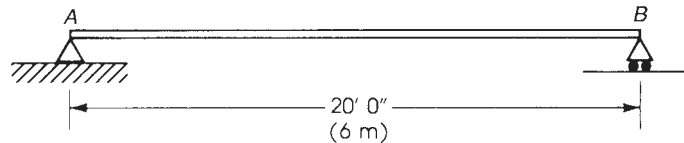


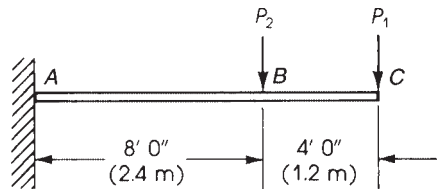
Figure 7.16 Problem 7.13.

- 7.14 Design the beam shown in Fig. 7.17 using  $\rho_{\max}$ . Draw the moment–resistance diagram and indicate where the reinforcing bars can be terminated. The beam carries a uniform dead load, including self-weight of 1.5 K/ft, and a live load of 2.2 K/ft. Use  $f'_c = 4$  ksi,  $f_y = 60$  ksi, and  $b = 12$  in.



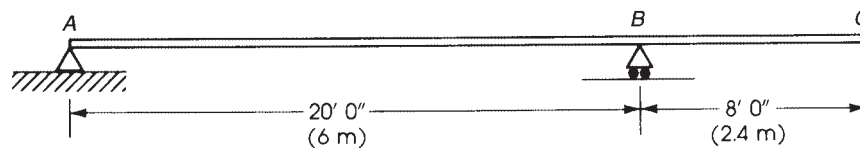
**Figure 7.17** Problem 7.14: Dead load = 1.5 K/ft (22.5 kN/m), live load = 2.2 K/ft (33 kN/m).

- 7.15** Design the beam shown in Fig. 7.18 using a steel ratio  $\rho = \frac{1}{2}\rho_b$ . Draw the moment–resistance diagram and indicate the cutoff points. Use  $f'_c = 3$  ksi,  $f_y = 60$  ksi, and  $b = 12$  in.



**Figure 7.18** Problem 7.15: Dead load = 2 K/ft (30 kN/m), live load (concentrated loads only) is  $P_1 = 10$  K (45 kN),  $P_2 = 16$  K (72 kN).

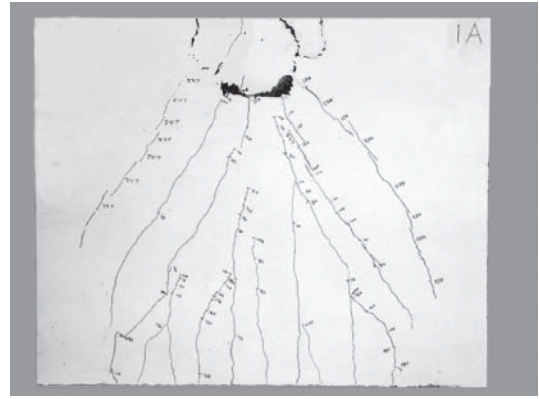
- 7.16** Design the section at support  $B$  of the beam shown in Fig. 7.19,  $\rho_{\max}$ . Adopting the same dimensions of the section at  $B$  for the entire beam  $ABC$ , determine the reinforcement required for part  $AB$  and draw the moment–resistance diagram for the beam  $ABC$ . Use  $f'_c = 4$  ksi,  $f_y = 60$  ksi, and  $b = 12$  in.



**Figure 7.19** Problem 7.16: Dead load = 6 K/ft (90 kN/m), live load = 4 K/ft (60 kN/m).

## CHAPTER 8

# DESIGN OF DEEP BEAMS BY THE STRUT-AND-TIE METHOD



Deep-beam flexural-shear failure.

### 8.1 INTRODUCTION

A strut-and-tie model of a structure is a valuable tool for the analysis and design of concrete members especially for regions where the plane sections assumption of beam theory does not apply. A strut-and-tie model visualizes a truss-like system in a structure and transmits forces from loading points to the supports. This method can be applied effectively in regions of discontinuity in the structural member, such as support areas, zones of load application, or areas with sudden change in the geometrical dimensions such as brackets and portal frames. In these regions, the plane sections do not remain plane after bending.

The ACI Code, Chapter 23 [1], and AASHTO [2] Section 5.6.3 introduce similar methods and will be discussed later in this chapter.

### 8.2 B- AND D-REGIONS

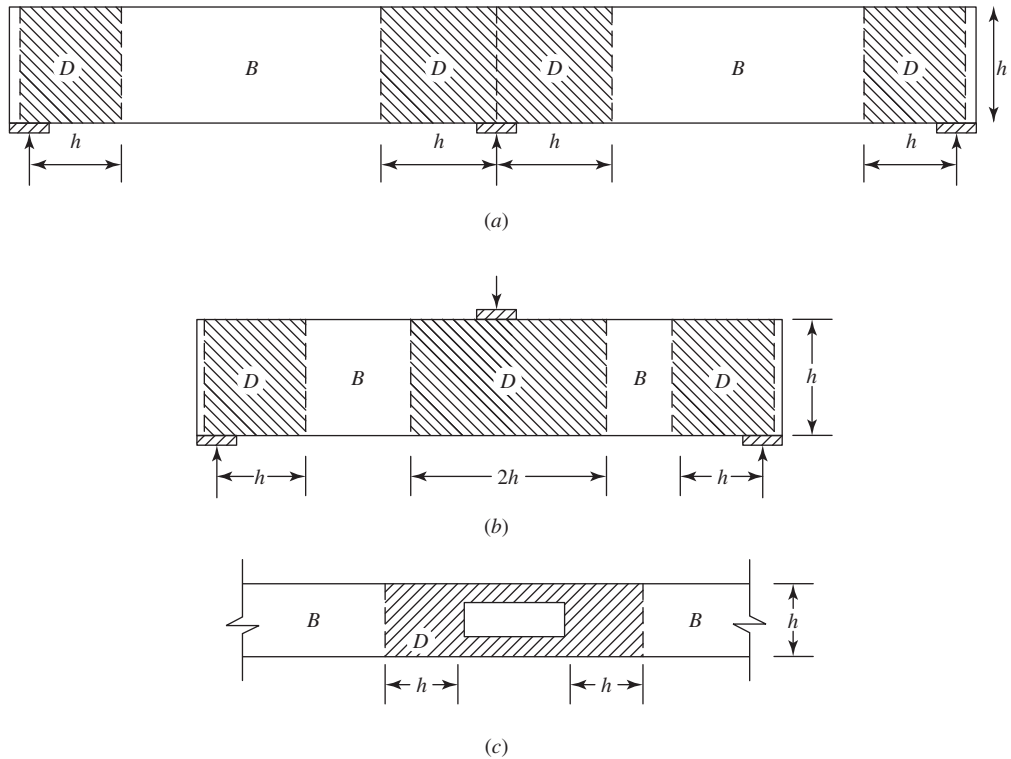
St. Venant's principle indicates that stresses due to axial load and bending approach a linear distribution at a certain distance from the discontinuity. This distance is generally taken as the larger dimension of the member cross section, that is, depth  $h$  or width  $b$ .

The region where stresses cannot be computed from the flexure formula are called  $D$ -regions (Fig. 8.1). The other regions of beam where bending theory and linear strain relationship applies are called  $B$ -regions (Fig. 8.1).

If two  $D$ -regions overlap or meet, they can be considered as a single  $D$ -region. ACI defines a  $D$ -region as the portion of the member within a distance equal to the member heights,  $h$  or depth  $d$  from a force discontinuity or a geometric discontinuity. For  $D$ -regions, maximum length-to-depth ratio would be equal to 2.

### 8.3 STRUT-AND-TIE MODEL

The strut-and-tie model can be represented by an idealized truss model with force acting at the different nodes. Compression members are defined as struts, tension members are defined as ties, and joints are defined as nodal zone. These three elements are illustrated in Fig. 8.2.



**Figure 8.1** D- and B-regions in beam. (a) continuous beam, (b) beam with concentrated load, and (c) beam with an opening [1]. Courtesy of ACI 318.

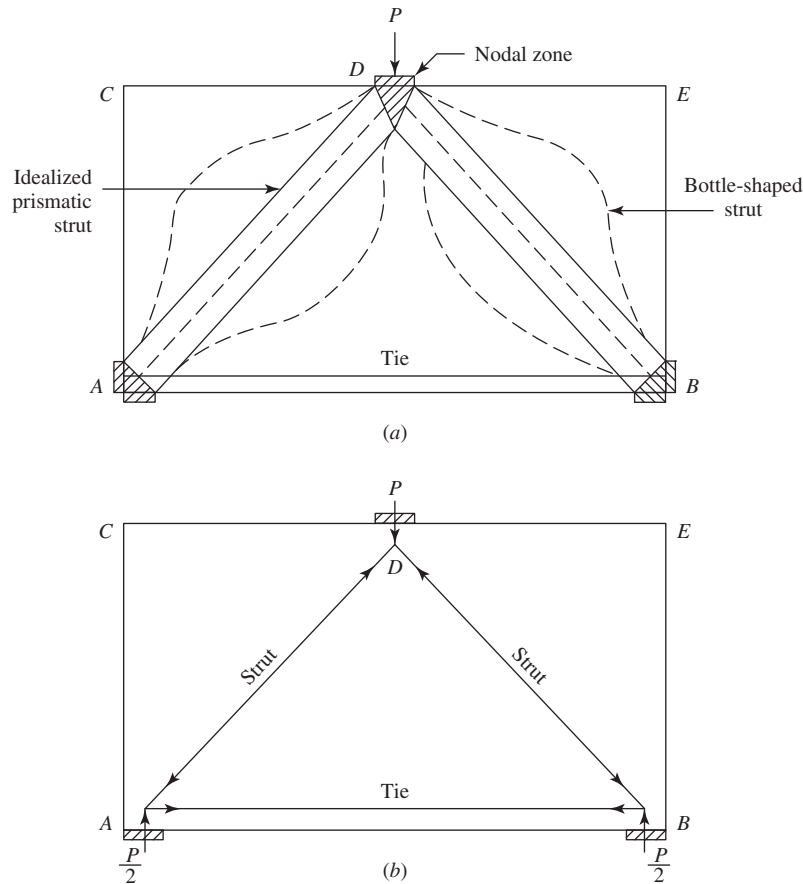
1. **Strut:** Compressive force resisted by concrete is called a strut. They are primarily made of concrete or a combination of concrete and compression reinforcement. A strut is idealized as a prismatic member of constant width or uniformly tapered width.

The ACI Code, Section R23.4.2 defines that if the effective compression strength  $f_{ce}$  differs at the two ends of a strut, due either to differential nodal zone strengths at the two ends, or to different bearing strength, the strut is idealized as a uniformly tapered compression member.”

As shown in Fig. 8.2 members  $AD$  and  $BD$  are called struts. The width of a strut is affected by location and distribution of a tie and its anchorage. Size and location of bearing also affect the width of a strut.

A bottle-shaped strut is a strut where the width of the compressed concrete at midlength of the strut can spread laterally. To simplify the design, bottle-shaped struts are idealized either as prismatic or uniformly tapered members. A taper of 1 to 2 is recommended as a first trial in design.

2. **Ties:** These are tensile members in a strut-and-tie model. They are made out of a combination of reinforcement and concrete. The contribution of concrete to the tensile resistance of a tie is neglected. However, the presence of concrete helps to improve stiffness and control deformations. Element  $AB$  in Fig. 8.2 is called a tie.



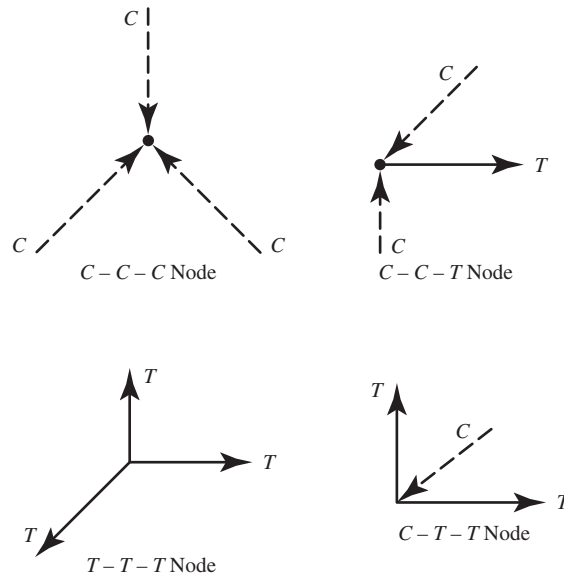
**Figure 8.2** (a) Strut-and-tie model and (b) idealized model. Courtesy of ACI 318.

- Nodes and nodal zone:** The intersection between the axes of two or more struts and ties defines the nodes in the model. Nodal zones are regions surrounding the nodes. These are confined areas of concrete that should satisfy strength requirements. Nodes  $A$ ,  $B$ , and  $D$  are shown in Fig. 8.2. In a structural model at least three forces must intersect at a node to satisfy equilibrium. Nodal zones are triangular in shape, implying that there are three force resultant approaches at the node. When two struts meet at different angles to the surface of the nodal zone, that surface can be taken to be normal to the resulting force from the two struts, as shown later in Fig. 8.6*d*.

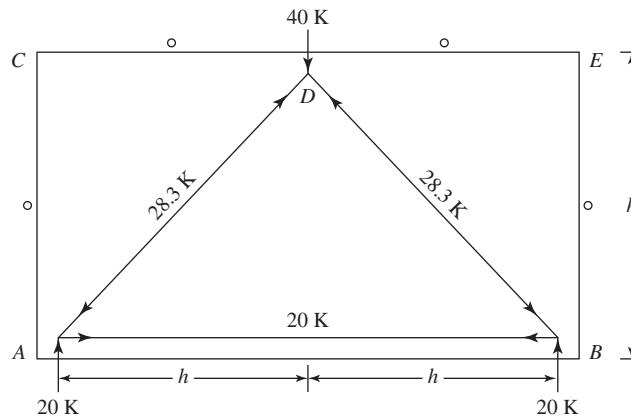
Forces at a node can vary between different combinations of compression and tensile forces,  $C-C-C$ ,  $C-C-T$ ,  $C-T-T$ ,  $T-T-T$  as shown in Fig. 8.3.

Now, consider the steel truss shown in Fig. 8.4. Due to symmetry, the reactions at  $A$  and  $B$  are equal,  $R_A = R_B = 20$  K, and from the equilibrium of joints  $A$  and  $D$ , the tensile force in  $AB = 20$  K, while the compressive force in  $AD$  or  $BD = 28.3$  K. Member  $AB$  is considered a tie, while  $AD$  and  $BD$  act as struts. The forces in the other members are equal to zero. Comparing this truss with the concrete beam in Fig. 8.2*a*, it can be seen that most of the areas  $ACD$  and  $BED$  and below the nodal zone  $D$  are not effective and act as fillers. The forces in the struts, for this loading condition, are





**Figure 8.3** Classification of nodes.



**Figure 8.4** Example of steel truss.

greater than the force in the tie. In this case, adequate concrete areas are available to act as idealized struts. Steel reinforcement is needed to act as a tie for  $AB$ . Proper anchoring of the ties are essential for a safe design and should be anchored in a nodal zone.

## 8.4 ACI DESIGN PROCEDURE TO BUILD A STRUT-AND-TIE MODEL

### 8.4.1 Model Requirements

- Equilibrium of forces should be maintained. Forces in strut and ties should be uniaxial.
- Struts must not cross or overlap each other. They can cross or overlap only at nodes.

- Ties can overlap struts or other ties.
- Minimum angle between struts and ties should be 25°.
- Tie should yield before strut crush (ductility).
- Tension in concrete is neglected.
- External forces should apply at nodes. If uniform load is present, that should resolve in concentrated load to apply at node.
- Prestressing is an external load.
- Reinforcement should be adequately anchored and provide sufficient detailing.

#### 8.4.2 Check for Shear Resistance

ACI Code, Section 9.9.2.1, specifies the following limitations for deep beams. This check is necessary prior to building a strut-and-tie model:

$$V_n \leq 10\sqrt{f'_c}b_wd \quad (8.1)$$

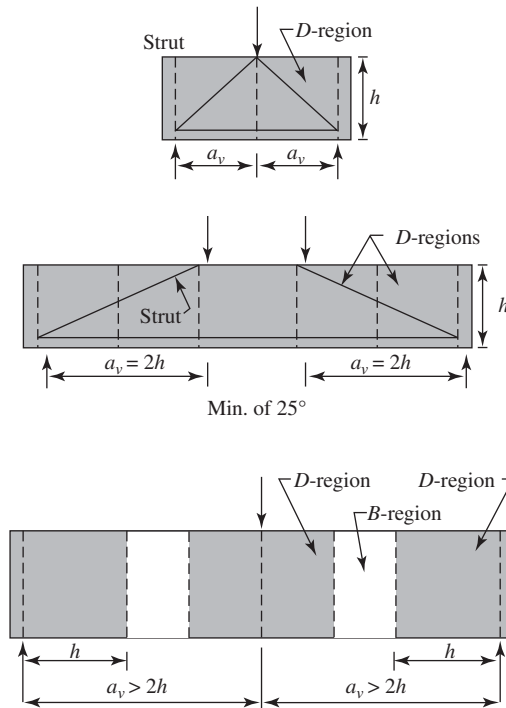
where

$$\begin{aligned} V_n &= \text{shear strength} \\ b_w &= \text{web width} \\ d &= \text{effective depth of section} \end{aligned}$$

If this equation is not satisfied, the cross section of the member should be increased.

#### 8.4.3 Design Steps According to ACI Section 23.2

- Define and isolate each region.* This should be defined as shown in Fig. 8.5 and Section 8.2. If the beam is shallow (with a large span-to-depth ratio), *B*-region can be much longer. In that type of beam, shear span is defined as being  $> 2h$ . If the beam has a small span-to-depth ratio, the *D*-region would cover the whole beam. And shear span is defined as  $< 2h$ .
- Determine the resultant forces acting on each D-region boundary.* Determine loads on structure and locate concentrated force either from reactions or from applied loads. Uniform load can be resolved into equivalent force resultant at node points.
- Select a truss model to transfer the resultant forces across the D-region.* In determining the geometry of a truss, the dimension of the struts, ties, and nodal zones shall be taken into account. The axes of the struts and ties should coincide, approximately, with the compression and tension fields. The selection of model geometry is the most important task in design. The selection of truss geometry may be done by visualizing the stress field that develops in a structure. For simple structures such as simple supported beams, the flow of stresses may be easily visualized. For a more complex structural system, the selection of a suitable truss model is more difficult.
- Compute the forces in strut and ties.* The strut-and-tie model should be in equilibrium with the applied loads and reactions. To calculate force in strut and ties, start computing forces at the joint. There are two equation of equilibrium, one for horizontal force and one for vertical force. These equations must be satisfied at each node.
- Determine the effective widths of the struts and nodal zones based on the concrete and steel strengths and the truss model chosen.* The effective width of the struts and nodal zones are determined considering the force from step (d) and the effective compressive strength. The strut, tie, and nodal zone all have finite widths that should be taken into account in selecting



**Figure 8.5** Description of deep and slender beams: (a) shear span,  $a_v < 2h$ , deep beam; (b) shear span,  $a_v = 2h$ , limit for a deep beam; and (c) shear span,  $a_v > 2h$ , slender beam. Courtesy of ACI.

the dimension of the truss. Thickness of strut, tie, and nodal zone should be the same as the member. Figure 8.6 shows a nodal zone. Vertical and horizontal forces equilibrate the force in the inclined strut. If the stresses are equal in all three struts, a hydrostatic nodal zone can be used and the width of struts will be in proportion to the force on the struts.

- f. *Design the tie anchorage.* Ties may fail if the end anchorage is not designed properly. The anchorage of the ties in the nodal zone is a critical part in the strut-and-tie model.
- g. *Check minimum steel requirement according to ACI 318, Section 9.9.3.1 and 9.9.3.2, minimum steel for deep beams.*

#### 8.4.4 Design Requirements According to ACI

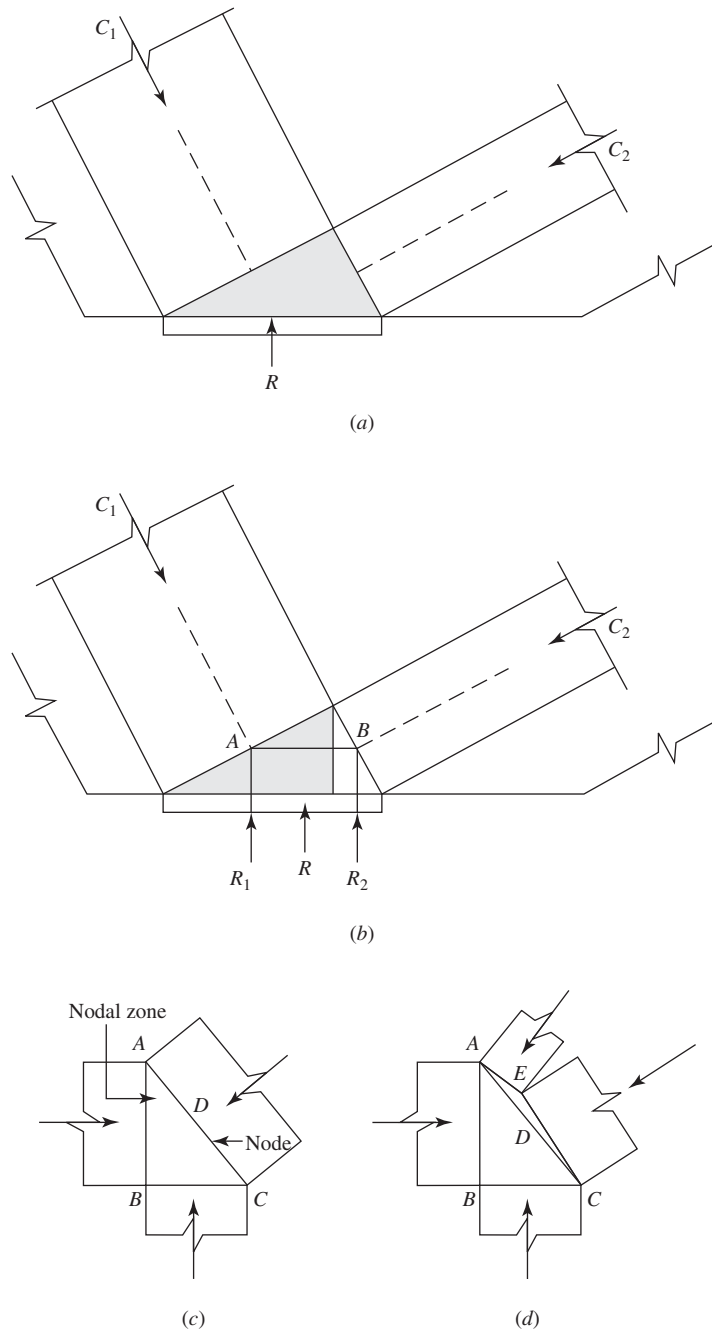
The design requirements for struts and ties can be summarized as follows:

1. *Design of Struts, Ties, and Nodal Zones:*

$$\phi F_n \geq F_u \quad (8.2)$$

where

- $F_u$  = force in strut, tie, or one face of nodal zone due to factored loads
- $F_n$  = nominal strength of a strut, tie, or nodal zone
- $\phi = 0.75$  for struts, ties, and nodal zone



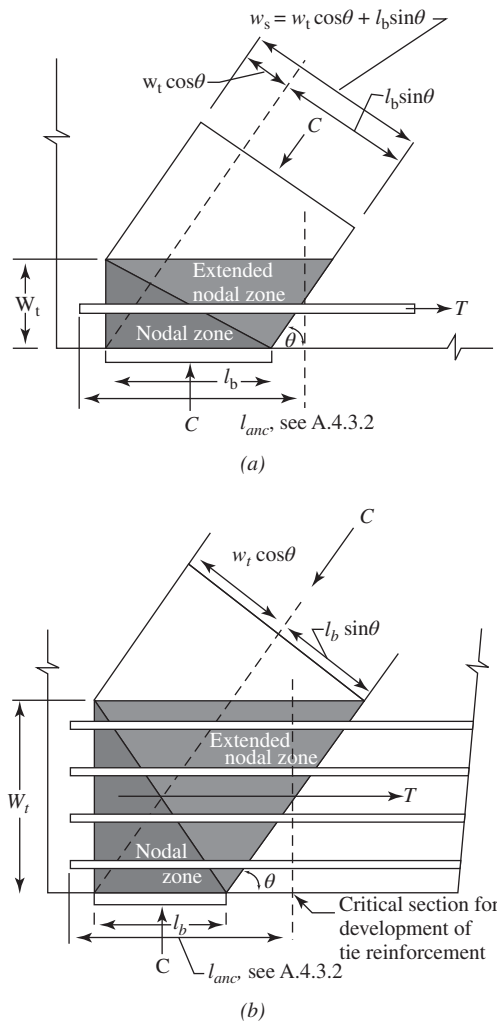
**Figure 8.6** Nodal zones [1]. (a) Nodal zone, (b) subdivision of nodal zone, (c) three struts acting on a nodal zone, and (d) struts  $AE$  and  $CE$  may be replaced by  $AC$ .

The nominal strength is obtained from the effective strength given in the ACI Code for each element.

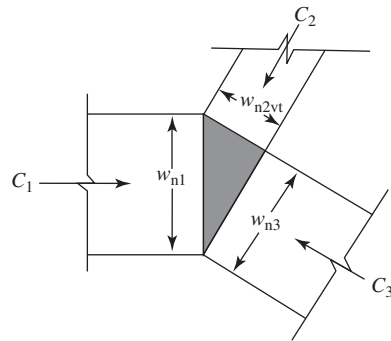
2. *Design of Struts.* Strut capacity is determined by the effective strength times its cross-sectional area.

The thickness of a strut is generally equal to member thickness. The width of a strut is generally controlled by the width of the nodal zone, bearing plate, or tie. When ties are anchored through development length, the strut width is affected by the location and detailing of reinforcement and its anchorage.

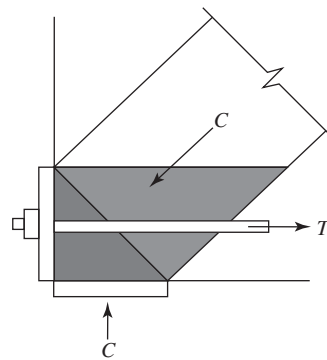
Figure 8.7 shows how a strut width  $w_s$  is influenced by the bearing pad width and tie width. Tie width also depends upon reinforcement and cover to reinforcement.



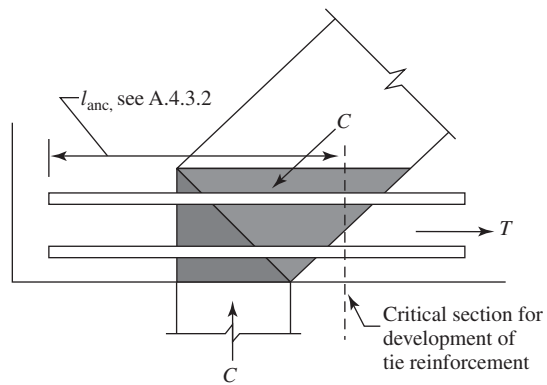
**Figure 8.7** Extended nodal zones and hydrostatic nodes [1]: (a) one layer of steel, (b) distributed steel, (c) geometry, (d) tension force anchored by a plate, and (e) tension force anchored by bond. Courtesy of ACI 318-14.



(c)



(d)



(e)

**Figure 8.7 (Continued)**

- a. Strength of Struts.** The nominal compressive strengths of a strut without longitudinal reinforcement,  $F_{ns}$ , shall be the smaller value of  $F_{ns}$  at the two ends of the strut such that:

$$F_{ns} = f_{ce}A_{cs} \quad (8.3)$$

where

$A_c$  = cross-sectional area at one end of strut

$f_{ce}$  = smaller effective compressive strength of concrete in strut and nodal zone.

That is the smaller of Eqs. 8.4 and Eqs. 8.5.

*Effective compressive strength of the concrete in a strut:*

$$f_{ce} = 0.85\beta_s f'_c \quad (8.4)$$

where  $\beta_s$  equals 1.0 for a prismatic strut; 0.75 for struts with the width of the midsection is larger than the width at the nodes (bottle-shaped struts) with adequate reinforcement to resist transverse tensile stresses; 0.60  $\lambda$  for struts with the width of the midsection is larger than the width at the nodes (bottle-shaped struts) without adequate reinforcement to resist transverse tensile stresses ( $\lambda = 1.0$  for normal weight concrete, 0.85 for sand-lightweight concrete, and 0.75 for all lightweight concrete); 0.40 for struts in tension members or tension flanges of member; and  $0.60\lambda$  for all other cases.

*Effective compressive strength of the concrete of a nodal zone:*

$$f_{ce} = 0.85\beta_n f'_c \quad (8.5)$$

where  $\beta_n$  equals 1.0 in nodal zones bounded by struts or bearing areas, or both, C-C-C node; 0.80 in nodal zones anchoring one tie, C-C-T node; and 0.60 in nodal zones anchoring two or more ties, C-T-T or T-T-T node.

- b. Reinforcement Crossing Struts.** The value  $\beta_s = 0.75$  is for bottle-shaped struts where reinforcement required is related to the tension force in the concrete due to the spreading of the strut. The axis of the strut shall be crossed by reinforcement, which is resisting the transverse tensile force resulting from the compression force spreading in the strut. The compressive force in the strut may be assumed to spread at a 2:1 slope (Fig. 8.8).

For  $f'_c \leq 6$  ksi, the value of transverse reinforcement can be calculated from

$$\sum \left( \frac{A_{si}}{bs_i} \right) (\sin \gamma_i) \geq 0.003 \quad (8.6)$$

where

$A_{si}$  = total area of reinforcement in  $i$ th layer crossing strut

$s_i$  = spacing of reinforcement in  $i$ th layer adjacent to surface of member

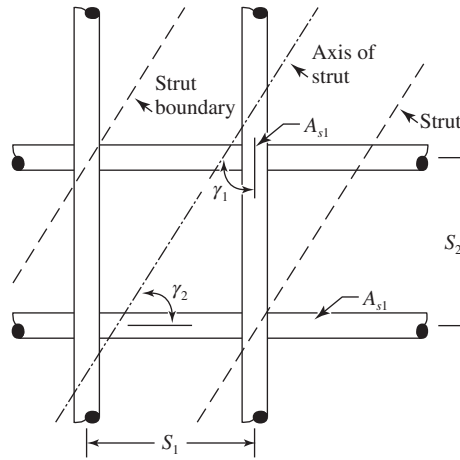
$b$  = width of member

$\gamma_i$  = angle between axis of strut and bars in  $i$ th layer of bars crossing strut

The transverse reinforcement as mentioned above shall be placed in either two orthogonal directions at angles  $\alpha_1$  and  $\alpha_2$  to the axis of the strut or in one direction at an angle  $\alpha$  to the axis of the strut. If the reinforcement is only in one direction,  $\alpha$  shall not be less than  $40^\circ$ .

- c. Compression Reinforcement in Struts.** Compression reinforcement can be used to increase the strength of a strut. The nominal strength of a longitudinal reinforced strut is

$$F_{ns} = f_{ce}A_c + A'_s f'_s \quad (8.7)$$



**Figure 8.8** Reinforcing bars crossing a strut. Courtesy of ACI 318-14.

where

$$\begin{aligned}
 F_{ns} &= \text{strength of longitudinal reinforced strut} \\
 A'_s &= \text{area of compression reinforcement in strut} \\
 f'_s &= \text{steel stress for } A'_s \text{ (} f'_s = f_y \text{ for grades 40–60)}
 \end{aligned}$$

Compression reinforcement should be properly anchored and parallel to the axis of the strut. This reinforcement should be located in the strut and enclosed in ties or spirals.

- 3. Design of Ties.** The tie includes the reinforcement and the prism of concrete around the tie. Tie design involves selecting the area of steel; and reinforcement is properly anchored and ensures that the reinforcement fits within the tie width.

*Strength of Ties.* The nominal strength of a tie  $F_{nt}$  is

$$F_{nt} = A_{st}f_y + A_{ps}(f_{se} + \Delta f_p) \quad (8.8)$$

where

$$\begin{aligned}
 A_{st} &= \text{area of non-prestressed reinforcement in tie} \\
 A_{ps} &= \text{area of prestressing reinforcement} \\
 f_{se} &= \text{effective stress after losses in prestressed reinforcement} \\
 \Delta f_p &= \text{increase in prestressing stress due to factored loads} \\
 A_{ps} &= \text{for nonprestressed members} \\
 f_{se} + \Delta f_p &\leq f_{py}
 \end{aligned}$$

It is permitted to take  $\Delta f_p = 60$  ksi for bonded prestressed reinforcement or 10 ksi for unbonded prestressed reinforcement.

The axis of reinforcement in a tie shall coincide with the axis of the tie in the strut-and-tie model. The effective tie width ( $w_t$ ) depends upon distribution of the tie reinforcement.

If the bars in the tie are in one layer, then

$$w_t = \text{diameter of bar in tie} + 2(\text{cover to surface of bars}) \quad (8.9)$$



Also, a practical upper limit of the tie width,  $w_t$ , can be taken as follows (ACI Code, Section R23.8.1):

$$w_{t(max)} = \frac{F_{nt}}{f_{ce}b_s} \quad (8.10)$$

where  $f_{ce}$  is the compressive strength of the nodal zone as computed in Eq. 8.5.

The concrete is included in the tie to establish the width of the faces of the nodal zone acted on by the ties. The concrete in a tie does not resist any load. Ties help in the transfer of loads from strut to ties or to bearing areas by bonding to the reinforcement.

4. *Design of Nodal Zone.* If all the strut stresses are equal at a node, a hydrostatic nodal zone can be used. The face of such a nodal zone is perpendicular to the axis of the strut and the width of the faces of the nodal zone is proportional to the forces in the strut.

The thickness of the nodal zone is generally taken the same as the thickness of the member. Calculation of the width of nodal zone is useful to calculate the width of compression strut first.

Nodal zones are generally triangular in shape; it is often necessary to determine one side of the triangle given others.

5. *Strength of Nodal Zones.* The nominal compression strength of a nodal zone,  $F_{nn}$ , is

$$F_{nn} = f_{ce}A_n \quad (8.11)$$

where  $A_n$  is the smaller of:

- The area of the face of the nodal zone on which  $F_{nn}$  acts; The area shall be taken perpendicular to the line of action of  $F_{nn}$ .
  - The area of the section through the nodal zone is, taken perpendicular to the line of action of the resultant force on the section.
- a. *Confinement in Nodal Zones.* Unless confining reinforcement is provided within the nodal zone and its effect is supported by tests and analysis, the calculated effective compressive stress on the face of a nodal zone due to the strut-and-tie forces should not exceed the following:

$$f_{ce} = 0.85\beta_n f'_c \quad (8.12)$$

where  $\beta_n$  equals 1.0 in nodal zones bounded by struts or bearing areas, or both, C–C–C node; 0.80 in nodal zones anchoring one tie, C–C–T node; and 0.60 in nodal zones anchoring two or more ties, C–T–T or T–T–T node.

## 8.5 STRUT-AND-TIE METHOD ACCORDING TO AASHTO LRFD

AASHTO uses a design approach similar to ACI's (Fig. 8.9). However, AASTHO uses different strength and resistance factors from those used by the ACI Code.

1. *Strut.* Resistance of compressive strut is given by

$$F_r = \phi F_n \quad (8.13)$$

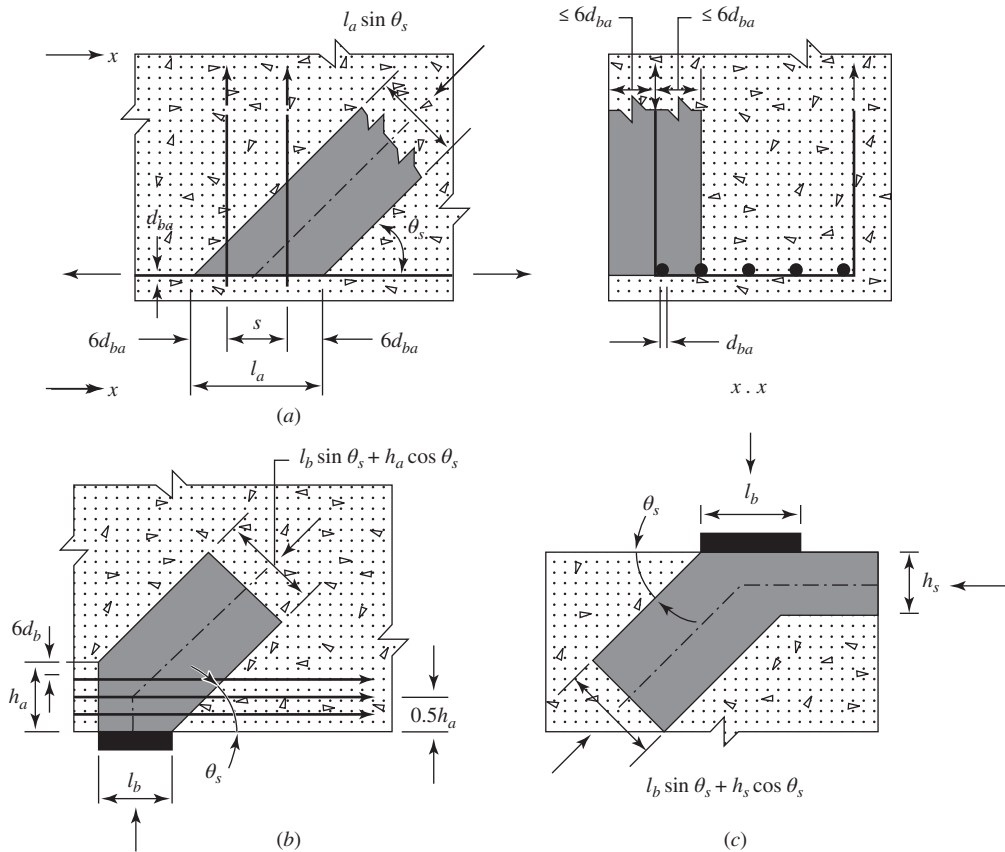
where

$\phi = 0.7$  for strut-and-tie model

$F_n =$  nominal compression resistance

$$F_n = \begin{cases} f_{ce}A_{cs} & \text{for unreinforced struts} \\ f_{ce}A_{cs} + A_{ss}f_y & \text{for reinforced strut} \end{cases} \quad (8.14)$$

$$(8.15)$$



**Figure 8.9** Influence of anchorage condition on effective cross-sectional area of strut: (a) Strut anchored by reinforcement, (b) strut anchored by bearing and reinforcement, and (c) strut anchored by bearing and strut. Source: AASHTO LRFD Bridge Design Specification, 2014. Used by permission.

where  $A_{cs}$  = effective cross-sectional area of strut determined from concrete area and anchorage conditions  $A_{ss}$  = area of reinforcement in strut

$$f_{ce} = \frac{f'_c}{0.8 + 170\epsilon_1} \leq 0.85f'_c \quad (8.16)$$

$$\epsilon_1 = \epsilon_s + (\epsilon_s + 0.002)\cot^2\alpha_s \quad (8.17)$$

where

$\alpha_s$  = smallest angle between compressive strut and adjoining tension ties

$\epsilon_s$  = tensile strain in concrete in direction of tension tie (in./in.)

$f'_c$  = specified compressive strength

**2. Ties.** For nominal resistance of ties the AASHTO equation is

$$F_{nt} = A_{st}f_y + A_{ps}(f_{se} + f_y) \quad (8.18)$$

This equation is the same as the ACI equation only  $F_Y$  is used instead of ( $\Delta f_p$ ).

$$\phi = \begin{cases} 0.9 & \text{for reinforced concrete} \\ 1.0 & \text{for prestressed concrete} \end{cases}$$

3. *Nodal Zone.* For the nodal zone the AASHTO recommends  $\phi = 0.7$  for all cases, and the effective width strength coefficient,  $\beta_n$ , is taken as 0.85 for *CCC* nodes, 0.75 and for *CCT* nodes, 0.65 for *CTT* and *TTT* nodes.

*Minimum Reinforcement:* AASHTO suggest that the *D*-region should contain orthogonal grid reinforcement near each face with maximum spacing less than or equal to 12 in. Orthogonal grid reinforcement requirement is not applicable for slabs and footing. The minimum steel ratio in each orthogonal direction should not be less than 0.003.

## 8.6 DEEP MEMBERS

Flexural members should be designed as deep beams if the ratio of the clear span,  $l_n$  (measured from face to face of the supports; Fig. 8.10), to the overall depth,  $h$ , is less than 4 (ACI Code, Section 9.9.1.1). The members should be loaded on one face and supported on the opposite face so that compression struts can develop between the loads and supports (Fig. 8.10). If the loads are applied through the bottom or sides of the deep beam, shear design equations for ordinary beams given earlier should be used. Examples of deep beams are short-span beams supporting heavy loads, vertical walls under gravity loads, shear walls, and floor slabs subjected to horizontal loads.

The definition of deep flexural members is also given in ACI Code, Section 9.9.1. The code defines flexural members as members where when the ratio of the clear span,  $l_n$ , to the overall depth,  $h$  (Fig. 8.10), is less than 4, regions loaded with concentrated loads within twice the member depth from the face of the support are considered deep flexural members. Such beams should be designed using nonlinear analysis or a strut-and-tie model (Fig. 8.11a).

### 8.6.1 Analysis and Behavior of Deep Beams

Elastic analysis of a deep beam is meaningful in the uncracked state only before cracking. Deep-beam cracking occurs generally at one-third or one-half of the strength load. After cracks develop, a redistribution of stresses is necessary. Elastic analysis shows the distribution of stresses

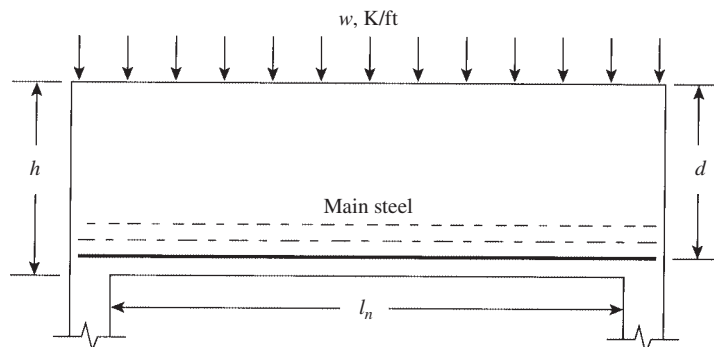
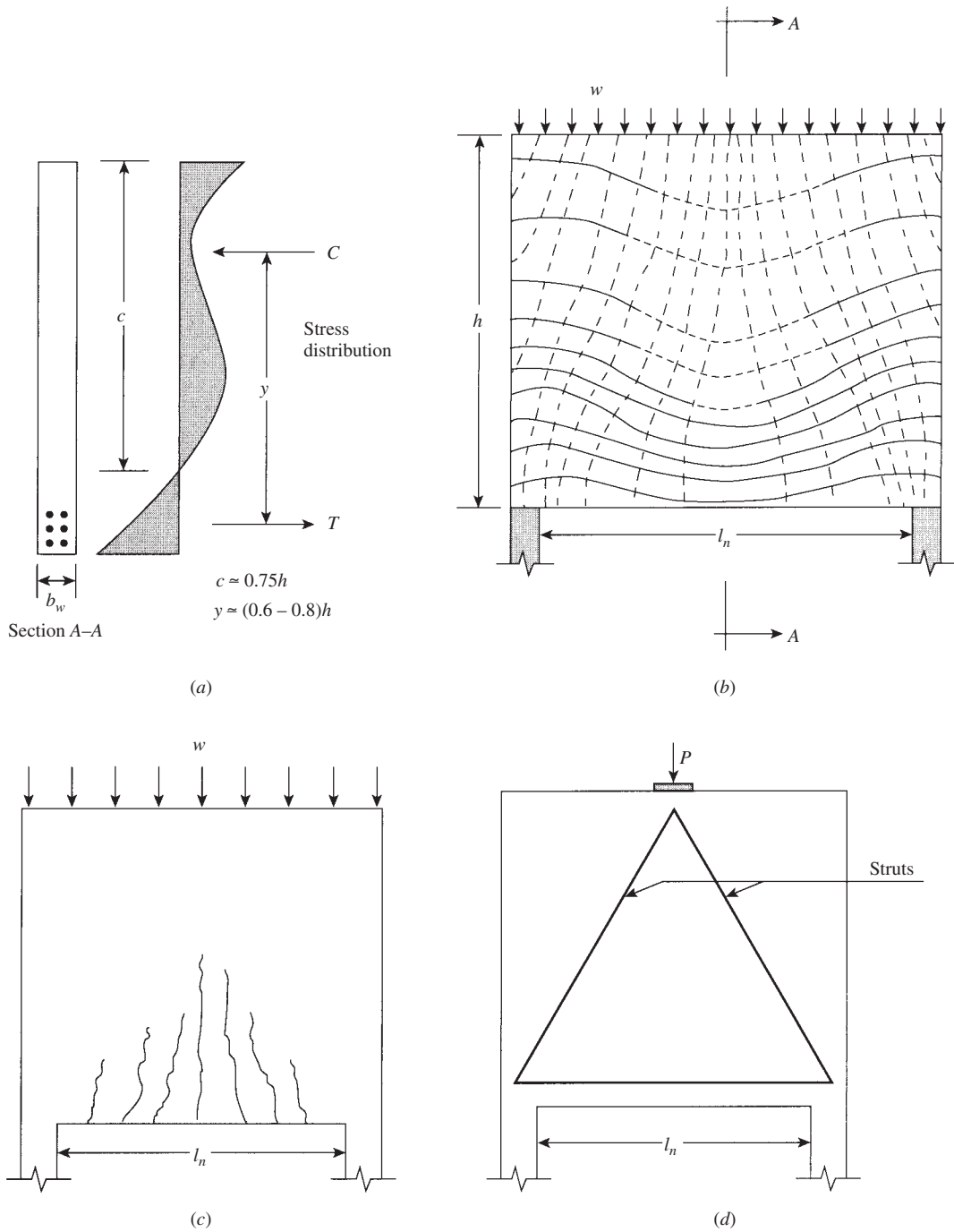


Figure 8.10 Single-span deep beam ( $l_n/d < 4$ ).



**Figure 8.11** Stress distribution and cracking: (a) elastic stress distribution, (b) stress trajectories (tension, solid lines, and compression, dashed lines), (c) crack patterns, and (d) truss model for a concentrated load applied at the wall upper surface.

that cause cracking and give guidance to the direction of cracking and the flow of stresses after cracking.

Figure 8.11a shows the elastic stress distribution at the midspan section of a deep beam, and Fig. 8.11b shows the principal trajectories in top-loaded deep beams. Solid lines indicate tensile stresses, whereas dashed lines indicate compressive stress distribution. Under heavy loads, inclined vertical cracks develop in the concrete in a direction perpendicular to the principal tensile stresses and almost parallel to the dashed trajectories (Fig. 8.11c). Hence, both horizontal and vertical reinforcement is needed to resist principal stresses. Moreover, tensile flexural reinforcement is needed within about the bottom one-fifth of the beam along the tensile stress trajectories (Fig. 8.11b). In general, the analysis of deep beams is complex and can be performed using truss models or more accurately using a finite-element approach or similar methods.

### 8.6.2 Design of Deep Beams Using Strut-and-Tie Model

Design of deep beam using the strut-and-tie model involves the following steps:

- a. Laying out a truss that will transmit the necessary loads. The loads, reactions, struts, and ties are all positioned in such a way that the centroid of each truss member and the line of action of all externally applied loads coincide at each joint. This is necessary for joint equilibrium.
- b. Once a truss has finalized, the joints and members of the truss are detailed to transmit the necessary forces.
- c. Verify the capacity of struts both at middle length and at the nodal zone.
- d. Design the tie and tie anchorage.
- e. Prepare design detail and check minimum reinforcement requirements. In deep beams minimum reinforcement shall not be less than  $0.0025b_w s$ , and  $s$  shall not exceed the smaller of  $d/5$  and 12 in. ACI 318 (Section 9.9.3.1 and 9.9.4.3). For AASHTO Section 5.6.3.6 the ratio is 0.003, and the spacing  $s$  shall not exceed the smaller of  $d/4$  and 12 in.
- f. Design for the rest of the structure, that is, the rest of the structure designed as a  $B$ -region. And the design should be integrated with the design of the  $D$ -region.
- g. Check for anchorage.

---

#### Example 8.1 Strut-and-Tie Deep Beam—ACI Method

A simply supported deep beam has a clear span equal to 12 ft, a total height equal to 6 ft, and a width of 18 in. The beam supports an 18-in.-square column at midspan carrying a dead load equal to 300 K, and a live load equal to 240 K. Design the beam using the strut-and-tie model, using  $f'_c$  equal to 4 ksi and  $f_y$  equal to 60 equal ksi. (Refer to Fig. 8.12.)

#### Solution

1. Calculate the factored loads:

$$\text{Weight of beam} = 15 \times 6 \times 1.5 \times 0.150 = 20 \text{ K}$$

Since the weight of the beam is small relative to the concentrated loads at midspan, add it to the concentrated load at midspan:

$$P_u = 1.2D + 1.6L = 1.2(300 + 20) + 1.6(240) = 768 \text{ K}$$

$$R_A = R_B = \frac{768}{2} = 384 \text{ K}$$

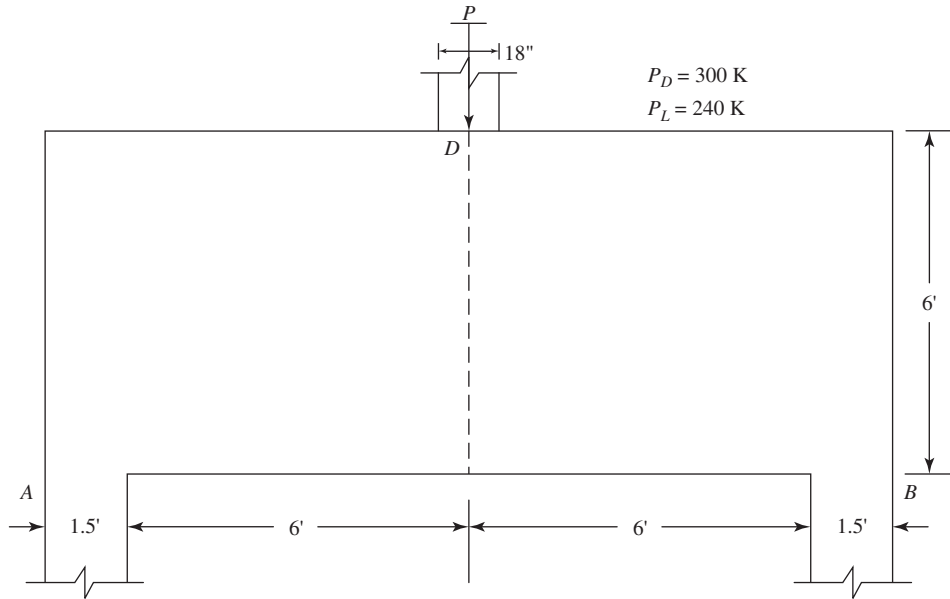


Figure 8.12 Example 8.1.

- Check if the beam is deep according to the ACI Code, Section 9.9. clear span,  $l_n = 12$  ft,  $h = 6$  ft, and  $l_n/h = 2 \leq 4$ , deep beam.
- Calculate the maximum shear strength of the beam cross section. Let  $V_u$  at  $A = R_A = 384$  K and assume  $d = 0.9h = 0.9 \times 72 = 64$  in.:

$$V_n = 10\sqrt{f'_c}b_wd = 10\sqrt{4000}(18 \times 64) = 728.6 \text{ K}$$

$$\phi V_n = 0.75(728.6) = 546 \text{ K} > V_u \quad \text{OK}$$

- Select a truss model. A triangular truss model is chosen. Assume that the nodes act at the centerline of the supports and at 6.0 in. from the lower or upper edge of the beam (Fig. 8.13). The strut-and-tie model consists of a tie  $AB$  and two struts  $AD$  and  $BD$ . Also, the reactions at  $A$  and  $B$  and the load  $P_u$  at  $D$  represent vertical struts:

$$\text{Length of diagonal strut } AD = \sqrt{60^2 + 81^2} = 100.8 \text{ in.}$$

Let  $\theta$  be the angle between the strut and the tie. Then  $\tan \theta = 60/81 = 0.7407$  and  $\theta = 36.5^\circ > 25^\circ$ , OK (ACI Section 23.2.7).

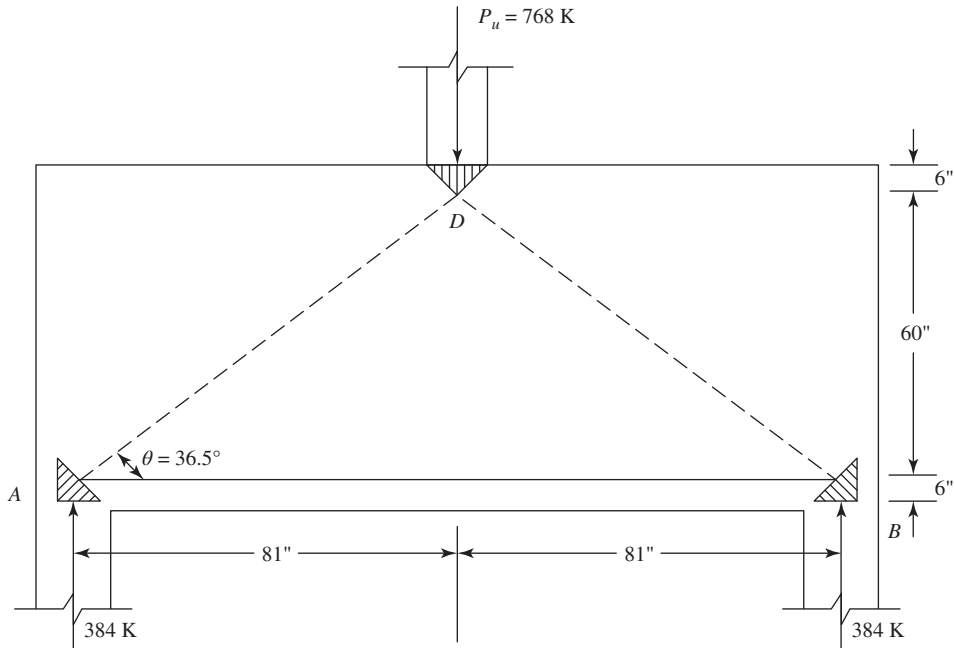
- Calculate the forces in the truss members:

$$\text{Compression force in strut } AD: F_{AD} = F_{BD} = 384 \left( \frac{100.8}{60} \right) = 645 \text{ K}$$

$$\text{Tension force in tie } AB: F_{AB} = 645 \left( \frac{81}{100.8} \right) = 518.3 \text{ K}$$

- Calculate the effective strength  $f_{ce}$ . Assume that confining reinforcement is provided to resist the splitting forces. Struts  $AD$  and  $BD$  represent the bottle-shaped compression members, and therefore  $\beta_s = 0.75$ , and

$$f_{ce} = 0.85\beta_s f'_c = 0.85 \times 0.75 \times 4 = 2.55 \text{ ksi}$$



**Figure 8.13** Example 8.1.

The vertical struts at  $A$ ,  $B$  and  $D$  have uniform sections, and therefore  $\beta_s = 1.0$  and

$$f_{ce} = 0.85 \times 1.0 \times 4 = 3.4 \text{ ksi}$$

The nodal zone  $D$  has  $C-C-C$  forces, and therefore  $\beta_s = 1.0$ . The effective strength at nodal zone  $D$  is given as

$$f_{cu} = 0.85 \times 1.0 \times 4 = 3.4 \text{ ksi}$$

Since the struts  $AD$  and  $BD$  connect to the other nodes, then  $f_{cu} = 2.55 \text{ ksi}$  controls to all nodal zones.

**7. Design of nodal zones:**

- a.** Design the nodal zone at  $A$ . Assume that the faces of the nodal zone have the same stress of  $2.55 \text{ ksi}$  and the faces are perpendicular to their respective forces:

$$\phi F_n \geq F_u \quad \text{or} \quad \phi f_{cu} A_c \geq F_u$$

where  $\phi$  equals  $0.75$  for struts, ties, and nodes.

The length of the horizontal face  $ab$ , Fig. 8.14a, is equal to  $F_u / (\phi f_{cu} b) = 384 / (0.75 \times 2.55 \times 18) = 11.2 \text{ in.}$

From geometry, the length  $ac = 11.2 (518.3/384) = 15.2 \text{ in.}$

Similarly, the length of  $bc = 11.2 (645/384) = 18.8 \text{ in.}$

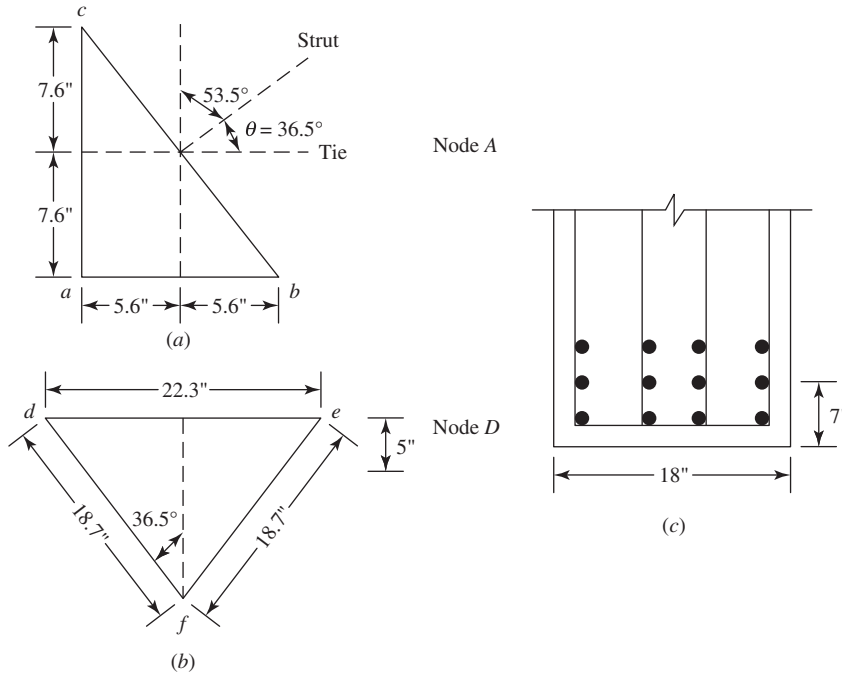
The center of the nodal zone is located at  $15.2/2 = 7.6 \text{ in.}$  from the bottom of the beam, which is close to  $6.0 \text{ in.}$ , assumed earlier.

- b.** Design the nodal zone at  $D$  (Fig. 8.14b):

The length of the horizontal face  $de = 768 / (0.75 \times 2.55 \times 18) = 22.3 \text{ in.}$

The length of  $df = ef = 22.3 (645/768) = 18.7 \text{ in.}$

The length of  $fg = 15.0 \text{ in.}$ , and the center of the nodal zone is located at  $15/3 = 5.0 \text{ in.}$  from the top, which is close to the assumed  $6.0 \text{ in.}$



**Figure 8.14** Example 8.1: Nodal zones: (a) at node A, (b) at node D, and (c) reinforcement details.

**8. Design of horizontal and vertical reinforcement:**

Vertical web reinforcements provided must be at least:

$$A_v = 0.0025bs$$

And horizontal web reinforcements provided must be at least:

$$A_{vh} = 0.0025bs$$

Spacing for both horizontal and vertical reinforcement shall not exceed  $d/5 = 14.4$  in. or 12 in., therefore use  $s = 12$  in.

$$A_v = A_{vh} = 0.0025 \times 18 \times 12 = 0.54 \text{ in.}^2 \text{ (per 12 inch)}$$

Use No. 5 at 12 in.:  $A_s = 2(0.31) = 0.62$ .

**a. Vertical Bars:** From Figure 8.14a, the angle between the vertical bars and strut is equal to  $53.5^\circ$

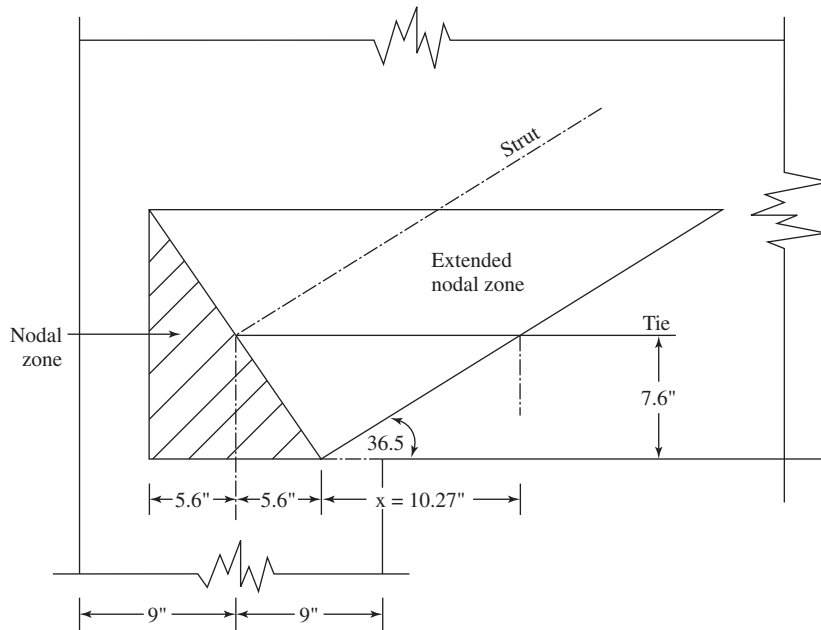
$$\left( \frac{A_{si}}{bs} \right) \sin \gamma = \frac{0.62}{18 \times 12} \sin 53.5 = 0.0023$$

**b. Horizontal Bars:** From Figure 8.14a, the angle between the vertical bars and strut =  $36.5^\circ$

$$\left( \frac{A_{si}}{bs} \right) \sin \gamma = \frac{0.62}{18 \times 12} \sin 36.5 = 0.0017$$

$$\sum \left( \frac{A_{si}}{b_s} \right) \sin \gamma = 0.0023 + 0.0017 = 0.004 > 0.003$$





**Figure 8.15** Example 8.1: Development of tie reinforcement.

**9. Design of the horizontal tie AB:**

- a.** Calculate  $A_s$ :

$$F_u = \phi A_s f_y \quad A_s = \frac{518.30}{0.75 \times 60} = 11.52 \text{ in.}^2$$

Use 12 no. 9 bars.  $A_s = 12 \text{ in.}^2$  in three rows as shown in Fig. 8.14c.

- b.** Calculate anchorage length. Anchorage length is measured from the point beyond the extended nodal zone, Fig. 8.15.  $\tan 36.5 = 7.6/x$ ; then  $x = 10.27 \text{ in.}$

Available anchorage length =  $10.27 + 5.6 + 9 - 1.5 \text{ in. (cover)} = 23.37 \text{ in.}$  Development length of no. 9 bars required =  $47.5 \text{ in. (Table 7.1)}$ , which is greater than  $23.37 \text{ in.}$  Use a standard  $90^\circ$  hook enclosed within the column reinforcement:

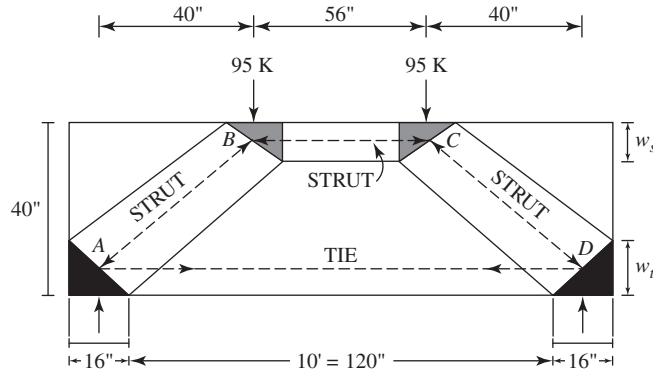
$$l_{dh} = \frac{(0.02\psi_e f_y) d_b}{\lambda \sqrt{f'_c}}$$

$$\psi_e = \lambda = 1.0 \quad d_b = 1.128 \text{ in.}$$

$$l_{dh} = \frac{0.02(1.0)(60,000)(1.128)}{(1.0)\sqrt{4000}} = 21.4 \text{ in.} < 23.37 \text{ in.}$$

**Example 8.2 ACI Method**

Design a simply supported deep beam for flexural and shear reinforcement that carries two-concentrated live load of 95 kips, shown in Fig. 8.16. The beam has a clear span of 10 ft, overall depth of 40 in. and width of 12 in. The beam is supported on 16-in.-wide columns. Given  $f'_c = 4 \text{ ksi}$ ,  $f_y = 60 \text{ ksi}$ . Assume the bearing plates at supports and loading points are 16 in.  $\times$  20 in. and 12 in.  $\times$  20 in., respectively.



**Figure 8.16** Idealized truss model.

### Solution

1. Calculate the factored load:

$$\text{Weight of the beam} = \left(10 + \frac{16}{12} + \frac{16}{12}\right) \left(\frac{40}{12}\right) \left(\frac{12}{12}\right) (0.150) = 6.3 \text{ K}$$

Since the weight of beam is small relative to concentrated loads, add to the concentrated loads.

$$P_u = 1.2D + 1.6L = 1.2(6.3) + 1.6 \times 95 = 160 \text{ K}$$

$$R_A = R_D = 160 \text{ K}$$

2. Check if beam is deep according to ACI Code, Section 9.9:

$$\text{Clear span, } l_n = 10 \text{ ft, } h = 3.3 \text{ ft, therefore } \frac{l_n}{h} = 3 < 4, \text{ deep beam.}$$

Check the bearing capacity at support and loading location:

- a. At supports *A* and *D*: The area of bearing plate at each support is  $A_c = 16 \times 20 = 320 \text{ in.}^2$  The bearing stresses at each support is:

$$\frac{V_u}{A_c} = \frac{160(1000)}{320} = 500 \text{ psi}$$

The nodal zone over the support is a compression-tension node (*C-C-T*), therefore:

$$f_{cu} = 0.85\beta_n f'_c = 0.85 \times 0.8 \times 4000 = 2720 \text{ psi, } \phi f_{cu} = 0.75(2720) = 2040 \text{ psi}$$

Check if

$$\phi f_{cu} > \frac{V_u}{A_c} \quad 2040 \text{ psi} > 500 \text{ psi} \quad \text{OK}$$

Therefore, the bearing plate at the support is adequate.

- b. At loading points *B* and *C*: The area of bearing plate at each loading point is  $A_c = 12 \times 20 = 240 \text{ in.}^2$  The bearing stress at each loading point is

$$\frac{V_u}{A_c} = \frac{160(1000)}{240} = 666.7 \text{ psi}$$

The nodal zone beneath each loading point is a pure compression node (*C-C-C*), therefore,

$$f_{cu} = 0.85\beta_n f'_c = 0.85 \times 1.0 \times 4000 = 3400 \text{ psi} \quad \phi f_{cu} = 0.75(3400) = 2550 \text{ psi}$$

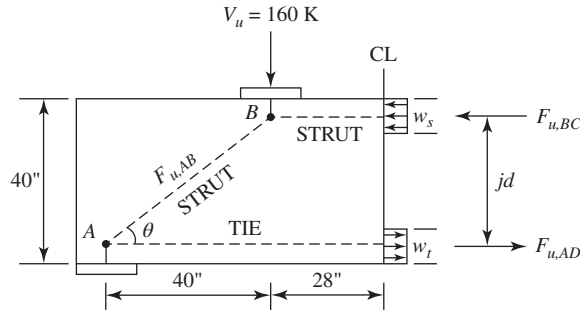


Figure 8.17 Free-body diagram of the left third of the beam.

Check if

$$f_{cu} > \frac{V_u}{A_c} \quad 2500 \text{ psi} > 666.7 \text{ psi} \quad \text{OK}$$

Therefore, the bearing plate loading point is adequate.

3. Calculate the maximum shear strength of beam cross section:

Let  $V_u$  at  $A = R_A = 160 \text{ K}$ , and assume  $d = 0.9h = 0.9 \times 40 = 36 \text{ in}$ .

$$V_n = 10\sqrt{f'_c}b_wd = 10 \times \sqrt{4000} \times 12 \times 36 = 273 \text{ K}$$

$$\phi V_n = 0.75 \times 273 = 205 > V_u = 160 \text{ K}$$

Therefore, the cross sectional dimensions are adequate.

4. Select strut and tie model and geometry:

A truss model is chosen as shown in Fig. 8.16. Assume that the nodes act at the centerline of the supports and loading points. Therefore, the horizontal position of  $A$ ,  $B$ ,  $C$ , and  $D$  are defined. The vertical position of the nodes must be as close to the top and bottom of the beam. To reach this goal, the lever arm,  $jd$  shown in Fig. 8.17, for the coupled forces should be at a maximum, or  $w_s$  and  $w_t$  should be at a minimum.

To minimize  $w_s$  and  $w_t$ , the strut and tie should reach their capacity:

For strut  $BC$ :

$$F_{u,BC} = \phi F_{nc} = \phi f'_{cu} A_c = \phi (0.85 \beta_s f'_c) b w_s$$

where  $\beta_s = 1.0$  (horizontal strut).

For tie  $AD$ :

$$F_{u,AD} = \phi F_{nt} = \phi f'_{cu} A_c = \phi (0.85 \beta_n f'_c) b w_t$$

where  $\beta_n = 0.8$  ( $C-C-T$  node).

As shown in Fig. 8.17, strut  $BC$  and tie  $AD$  form a couple, therefore  $F_{u,BC} = F_{u,AD}$  or

$$\phi (0.85 \times 1.0 f'_c) b w_s = \phi (0.85 \times 0.8 f'_c) b w_t,$$

$$w_t = 1.25 w_s$$

$$jd = 40 - \frac{w_s}{2} - \frac{w_t}{2} = 40 - 1.125 w_s$$

By writing the moment equilibrium about point  $A$  we have:

$$V_u(40) - F_{u,BC}(jd) = 0$$

$$(160)(40) - \phi (0.85 \beta_s f'_c) b w_s (40 - 1.125 w_s) = 0$$

$$(160)(40) - 0.75(0.85 \times 1.0 \times 4)(12)w_s(40 - 1.125w_s) = 0$$

$$w_s = 6.4 \text{ in.} \quad \text{and} \quad w_t = 1.125w_s = 7.2 \text{ in.}$$

Therefore

$$jd = 40 - \frac{7.2}{2} - \frac{6.4}{2} = 33.2 \text{ in.}$$

5. Calculate the forces in all truss members:

$$\text{length of diagonal struts, AB and CD} = \sqrt{40^2 + 33.2^2} = 52 \text{ in.}$$

Let  $\theta$  be the angle between the strut and the tie,

$$\tan \theta = \frac{33.2}{40} = 0.831, \quad \theta = 39.7^\circ > 25^\circ \text{ OK}$$

$$F_{u,BC} = F_{u,AD} = 160 \left( \frac{40}{33.2} \right) = 192.5 \text{ K}$$

$$F_{u,AB} = F_{u,CD} = \frac{160}{\sin 39.7^\circ} = 250 \text{ K}$$

6. Calculate the effective stress,  $f_{ce}$ :

For struts:

Assume that confining reinforcements is provided to resist the splitting forces. Struts,  $AB$ ,  $BC$ , and  $CD$  represent the bottle-shaped compression members, therefore,  $\beta_s = 0.75$

$$f_{ce} = 0.85\beta_s f'_c = 0.85 \times 0.75 \times 4 = 2.55 \text{ ksi}$$

For nodes:

The nodal zone  $B$  or  $C$  has  $C-C-C$  forces, therefore  $\beta_n = 1.0$ .

$$f_{ce} = 0.85\beta_n f'_c = 0.85 \times 1 \times 4 = 3.4 \text{ ksi}$$

Since the three struts are connected to the other nodes, then  $f_{cu} = 2.55 \text{ ksi}$  controls all nodes.

7. Design of nodal zones:

- a. Design the nodal zone at  $B$  or  $C$  (Fig. 8.18a): As shown in Fig. 8.19a, the width of the top strut is

$$w_{st} = 12 \sin \theta + w_s \cos \theta = 12 \sin 39.7^\circ + 6.4 \cos 39.7^\circ = 11 \text{ in.}$$

- b. Design the nodal zone at  $A$  or  $D$  (Fig. 8.19b):

$$w_{sb} = 16 \sin \theta + w_t \cos \theta = 16 \sin 39.7^\circ + 7.2 \cos 39.7^\circ = 14.4 \text{ in.}$$

Struts  $AB$ ,  $BC$ , and  $CD$  represent the bottle-shaped compression members,  $\beta_s = 0.75$ .

$$\phi F_{ns} = \phi(0.85\beta_s f'_c)bw_{st} = 0.75(0.85)(0.75)(4)(12)(11) = 251.3 \text{ K}$$

$$\phi F_{ns} = \phi(0.85\beta_s f'_c)bw_{sb} = 0.75(0.85)(0.75)(4)(12)(14.4) = 329 \text{ K}$$

$$\text{use } \phi F_{ns} = 251.3 \text{ K}$$

Because  $\phi F_{ns}$  is higher than the required forces, struts  $AB$ ,  $BC$ , and  $CD$  are adequate.

$$\phi F_{ns} \geq F_{u_{AB,CD}} \quad \text{or} \quad 251.3 > 250 \quad \text{and} \quad \phi F_{ns} \geq F_{u_{BC}} \quad \text{or} \quad 251.3 > 250 \quad \text{OK}$$

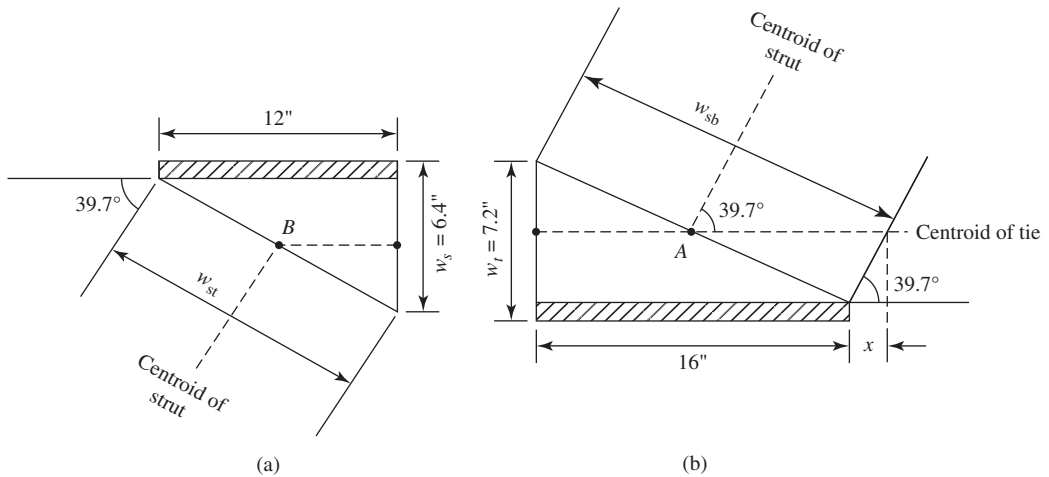
8. Design of horizontal and vertical reinforcement:

Vertical web reinforcements provided must be at least:

$$A_v = 0.0025bs$$

And horizontal web reinforcements provided must be at least:

$$A_{vh} = 0.0025bs$$



**Figure 8.18** (a) Node zone at B or C. (b) Node zone at A or D.

Spacing for both horizontal and vertical reinforcement shall not exceed  $d/5 = 7.2$  in. or 12 in., therefore use  $s = 7$  in.

$$A_v = A_{vh} = 0.0025 \times 12 \times 7 = 0.21 \text{ in.}^2 \text{ (per 7 in.)}$$

$$A_v = A_{vh} = 0.21 \times 7/12 = 0.36 \text{ in.}^2 \text{ (per 12 in.)}$$

Use No. 4 at 12 in.:  $A_s = 2(0.2) = 0.4 \text{ in.}^2$  (two legs)

**a. Vertical Bars:** From Fig. 8.18b, the angle between the vertical bars and strut is equal to  $50.3^\circ$

$$\left(\frac{A_{si}}{bs}\right) \sin\gamma = \frac{0.4}{12 \times 12} \sin 50.3 = 0.0021$$

**b. Horizontal Bars:** From Fig. 8.18b, the angle between the vertical bars and strut =  $39.7^\circ$

$$\left(\frac{A_{si}}{bs}\right) \sin\gamma = \frac{0.4}{12 \times 12} \sin 39.7 = 0.0017$$

$$\sum \left(\frac{A_{si}}{b_s}\right) \sin\gamma = 0.0021 + 0.0017 = 0.0038 > 0.003$$

**9. Design of the horizontal tie AD:**

Required tie reinforcement

$$F_u = \phi A_s f_y \quad A_s = \frac{192.5}{0.75 \times 60} = 4.27 \text{ in.}^2$$

Provide six no. 8 bars in three rows,  $A_{st} = 4.8 \text{ in.}^2$

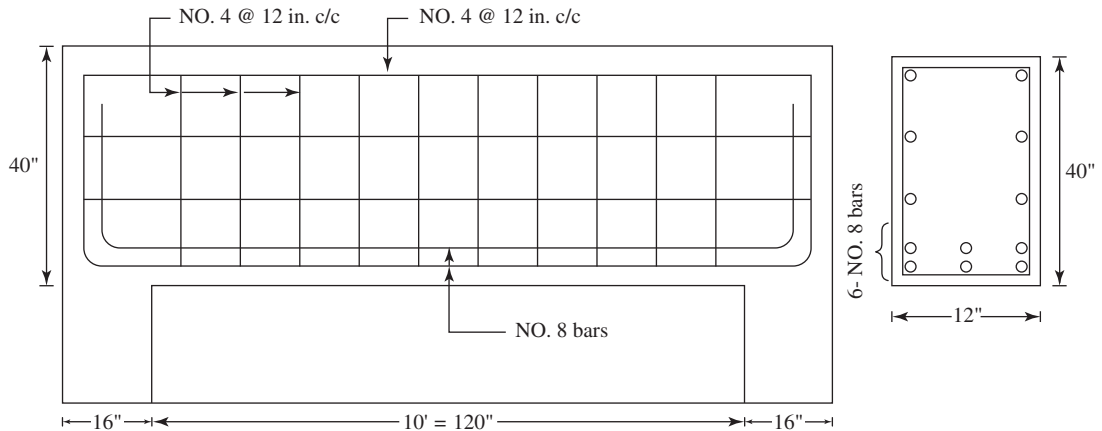
**10. Calculate anchorage length:**

Anchorage length is measured from the point beyond the extended nodal zone:

$$\tan 39.7^\circ = \frac{w_t}{2x} = \frac{7.2}{2x}$$

$$x = 4.5 \text{ in.}$$

Available anchorage length:  $4.5 + 16 - 1.5 = 19$  in.



**Figure 8.19** Reinforcement details.

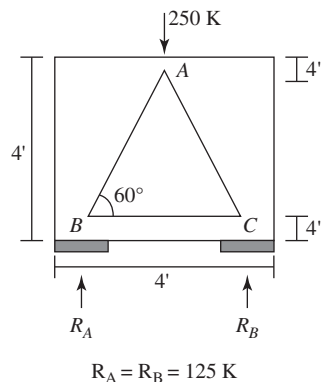
Development length of No. 8 bars required =  $47.5(1) = 47.5$  inch (table 7), which is greater than 19 in. Use a standard  $90^\circ$  hook enclosed with column reinforcement:

$$l_{dh} \frac{(0.02\psi_e f_y) d_b}{\lambda \sqrt{f'_c}} = \frac{0.02(1.0)(60000)(1.0)}{(1.0)\sqrt{4000}} = 19 \leq 19 \text{ in. OK}$$

Reinforcement details are shown in Fig. 8.19.

### Example 8.3 AASHTO LRFD Method

A simply supported deep beam has a depth of 4 ft. The clear span is 4 ft, and the width is 1 ft (Fig. 8.20). The beam is carrying a total factored load of 250 K at midspan. Design the beam using the strut-and-tie model. Assume  $f'_c = 4$  ksi,  $f_y = 60$  ksi, and bearing pads of 8 in.  $\times$  8 in.



**Figure 8.20** Example 8.3: Idealized deep beam.

### Solution

1. Calculate reactions. Total factored load given is 250 K. The reaction is

$$R_A = R_B = 125 \text{ K}$$

2. Check if beam is deep. Height of beam ( $h$ ) is 4 ft, clear span ( $l_n$ ) is 4 ft.

$$\frac{l_n}{h} = \frac{4}{2} = 2 < 4 \text{ ft} \quad (\text{Entire beam is in } D - \text{region})$$

3. Calculate maximum shear strength of the beam cross section. Let  $V_u$  at A be given as  $R_A = 125 \text{ K}$  and assume

$$d = 0.9h = 0.9 \times 48 = 43.2 \text{ in.}, \text{ use } 43 \text{ in.}$$

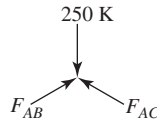
$$\phi V_n = \phi(10)\sqrt{f'_c}b_w d = 0.75(10)\sqrt{4000}(12)(43) = 244 \text{ K} > V_u = 125 \text{ K} \quad (\text{OK})$$

4. Select a truss model. A triangular truss model is chosen. Assume that nodes act at the centerline of the supports and 4 in. from the lower and upper edges of the beam. The strut-and-tie model consists of a tie,  $BC$ , and two struts  $AB$  and  $AC$ .

Let the angle between the strut and tie be  $\theta = 60^\circ > 25^\circ$  OK.

5. Calculate the forces in truss members.

At the joint A (C-C-C) nodes:

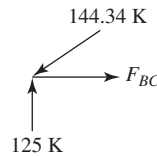


$$F_{AB} = F_{AC}$$

$$F_{AB} \cos 30^\circ = 250 \text{ K}$$

$$F_{AB} = \frac{250}{\cos 30^\circ} = 144.34 \text{ K}$$

At joint B (C-C-T) nodes:



$$F_{BC} = 144.34 \cos 60 = 72.17 \text{ K}$$

6. Check size of bearing:

Effective strength of node A (C-C-C node) =  $0.85f'_c\phi$

Effective strength of node B, C (C-C-T node) =  $0.75f'_c\phi$

$$\text{Bearing area required at node A} = \frac{P_u}{0.85f'_c\phi} = \frac{250}{0.85 \times 4 \times 0.7} = 105 \text{ in.}^2$$

$$\text{Bearing area required at nodes B and C} = \frac{P_u}{0.85f'_c\phi} = \frac{125}{0.75 \times 4 \times 0.7} = 60 \text{ in.}^2$$

Bearing area proposed =  $8'' \times 8'' = 64 \text{ in.}^2 < 105 \text{ in.}^2$  (not safe)

Since the width of beam is  $12''$ , keep a "width with clear spacing 1.5" on both sides. The bearing pad length  $L$  is

$$L = \frac{105}{9} = 11.67''$$

Use  $9'' \times 12''$  bearing pad at the load position and  $8'' \times 8''$  bearing pad at support.

7. Chose tension tie reinforcement:

$$\phi = 0.9 \text{ for tension tie}$$

$$P_u = \phi f_y A_{st}$$

$$A_{st} = \frac{72.17}{(0.9)(60)} = 1.34 \text{ in.}^2$$

There can be three bars of reinforcement:

$$\frac{1.34}{3} = 0.447 \text{ in.}^2$$

Use 3 three no. 6 bars:

$$A_s = 3 \times 0.44 = 1.32 \text{ in.}^2$$

8. Check capacity of struts:

$$F_{AB} = F_{AC} = 144.34 \text{ K}$$

$$\epsilon_s = \frac{P_u}{A_{st} E_s} = \frac{722}{1.34 \times 29,000} = 1.85 \times 10^{-3} \text{ in./in.}$$

where  $\epsilon_s$  is the tensile strain in the concrete in the direction of tension tie (in./in.),

$$\begin{aligned} \epsilon_l &= \epsilon_s + (\epsilon_s + 0.002) \cot^2 \alpha \\ &= 1.85 \times 10^{-3} + (1.85 \times 10^{-3} + 0.002) \cot^2(60) = 3.13 \times 10^{-3} \text{ in./in.} \end{aligned}$$

$$\begin{aligned} f_{ce} &= \frac{f'_c}{0.8 + 170\epsilon_l} \leq 0.85f'_c \\ &= \frac{4}{0.8 + 170(3.13 \times 10^{-3})} \leq 0.85(4) = 3.00 \leq 3.4 \quad \text{OK} \end{aligned}$$

$$A_{cs} = w \times (l_b \sin \theta_s + h_a \cos \theta_s)$$

where

$$\begin{aligned} w &= \text{width of deep beam} = 12'' \\ l_b &= \text{bearing pad } 8'' \text{ and } 12'' \\ \theta_s &= 60^\circ \end{aligned}$$

$$\text{At node } B, C \quad h_a = \text{width of tie} = 8 \left( \frac{72.2}{125} \right) = 4.62 \text{ in., use } 5 \text{ in.}$$

$$w_s = l_b \sin \theta_s + h_a \cos \theta_s = 8 \sin 60^\circ + 5 \cos 60^\circ = 9.42 \text{ in., use } 9.5 \text{ in.}$$

At node A:

Width of bearing pad = 12 in.

$$\text{Width of strut} = 12 \left( \frac{144.34}{250} \right) = 6.92 \text{ in.}$$

Therefore  $w_s = 9.5$  in. governs

$$A_{cs} = 12 \times 9.5 = 114 \text{ in.}^2$$

$$F_r = \phi F_n = 0.7f_{ce}A_{cs} = 0.7(3)(114) = 239 \text{ K} > 144.34 \text{ K}$$

Therefore, strut reinforcement is not required.



9. Check anchorage of tension ties. There is almost no embedded length to devolve no. 6 tension tie reinforcement. Therefore, provide anchor plate or headed plate or headed ends.

10. Check nodal zone stress:

$$f_c = \frac{72.2}{2(4)(12)} = 0.752 \text{ ksi}$$

Then limiting nodal zone stress is

$$0.75\phi f'_c = 0.75(0.7)(4) = 2.1 \text{ ksi} > 0.752 \quad \text{OK.}$$

11. Crack control reinforcement. The minimum ratio of reinforcement to gross concrete area is 0.003 in each direction. The maximum spacing is the smaller of  $d/4 = 43/4 = 10.75$  or 12 in. Therefore, use 10" c/c

$$A_{s,\min} = 0.003 \times 12 \times 48 = 1.73 \text{ in.}^2$$

$$\text{Provide no. 4 bars} = \frac{1.73}{0.2} = 8.65 \approx 10$$

Provide 10 no. 4 bars 5 each face at 10 in. c/c.

12. Details of reinforcement are shown in Fig. 8.21.

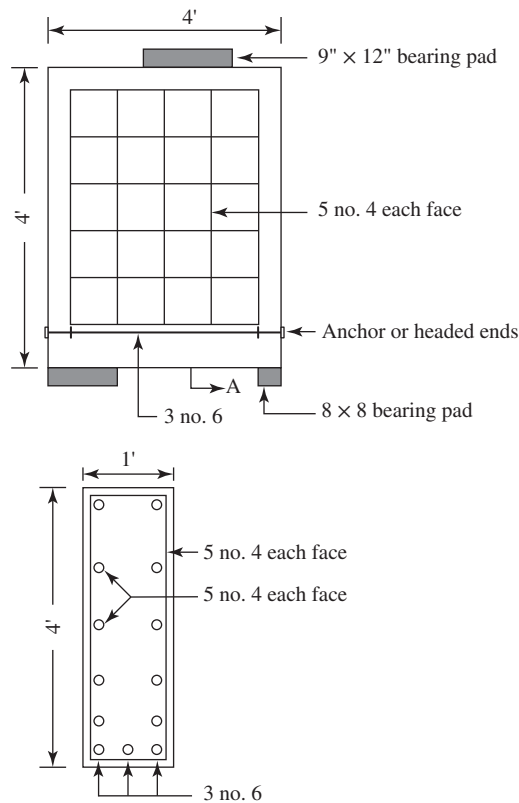
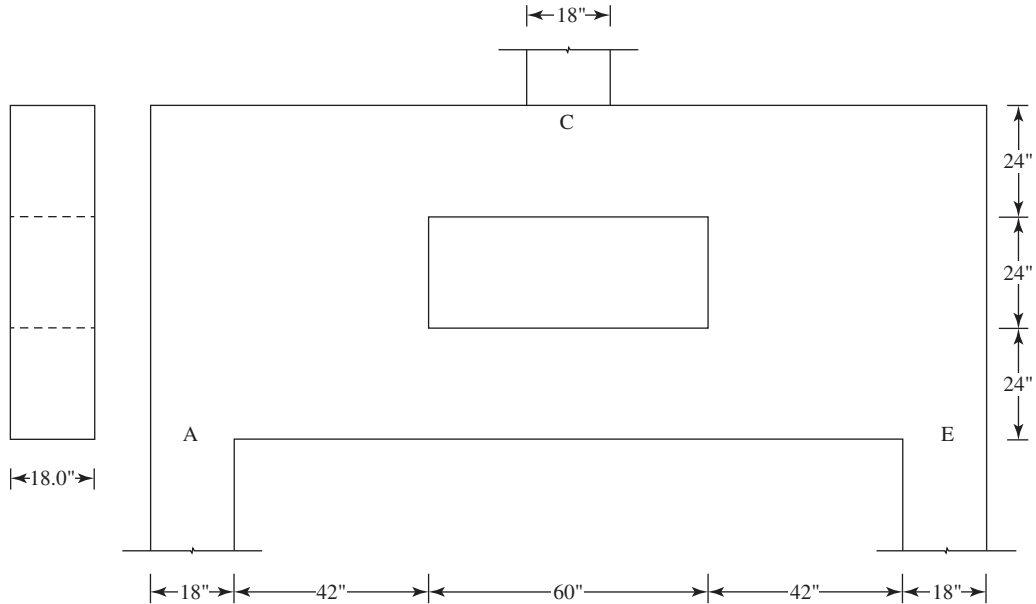


Figure 8.21 Example 8.3: Deep-beam reinforcement details.

**Example 8.4 ACI Method**

A simply supported deep beam with an opening, shown in Figure 8.22, has a clear span equal to 12 ft, a total height equal to 6 ft, and a width of 18 in. The beam supports an 18 in. - square column at midspan carrying a service dead load of 300 K, and a live service load of 240 K.  $f'_c = 4$  ksi,  $f_y = 60$  ksi,  $E_s = 29 * 106$  psi.



**Figure 8.22** Example 8.4: Idealized deep beam with an opening.

1. Calculate the factored loads:
2. Check if beam is deep beam according to ACI Code, Section 9.9,  $l_n = 12$  ft,  $h = 6$  ft.
3. Calculate Maximum Shear Strength:
4. Select Truss Model:  
See Figure 8.23
5. Calculate Element Forces:
6. Calculate Effective Strength:  
Struts connect to all nodes therefore, 2.55 ksi controls to all nodal zones.
7. Design Nodal zones:

Nodes A, E (Figure 8.24)

Nodes C see (Figure 8.24)

Nodes B, E (Figure 8.24)

Design Horizontal and Vertical reinforcement:

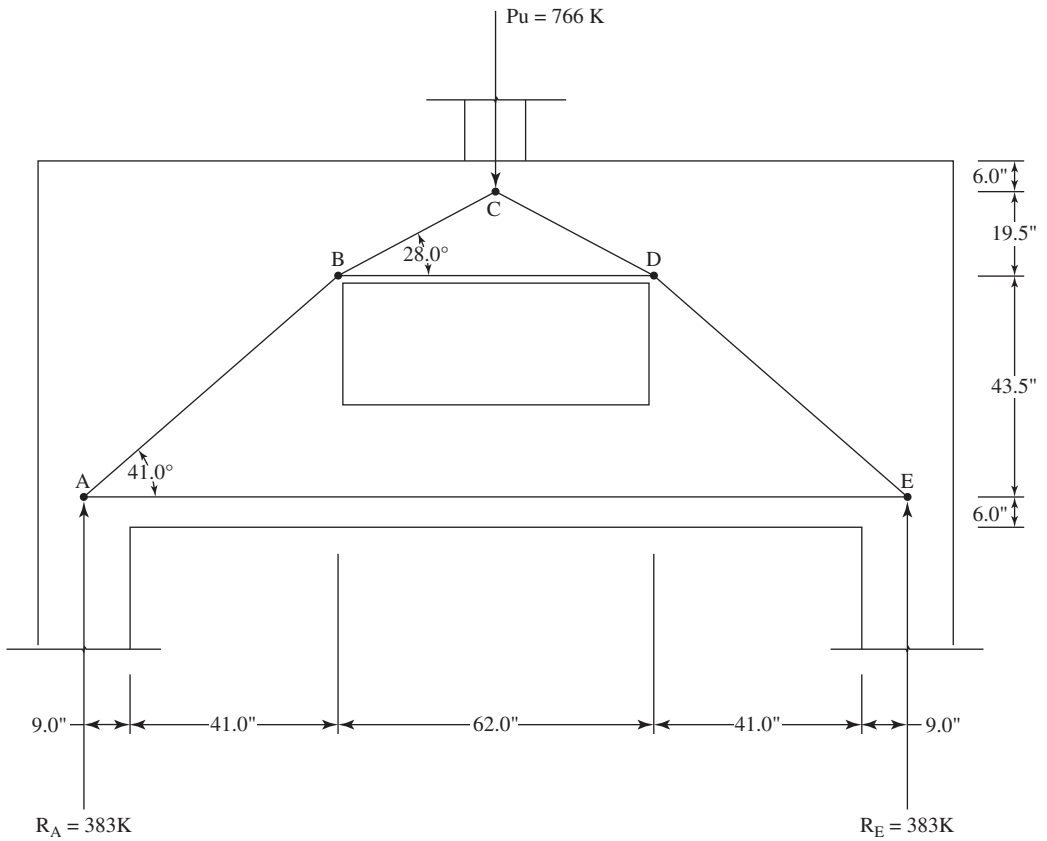
Suggest No. 5 bars @ 12 in.

Vertical Bars below opening

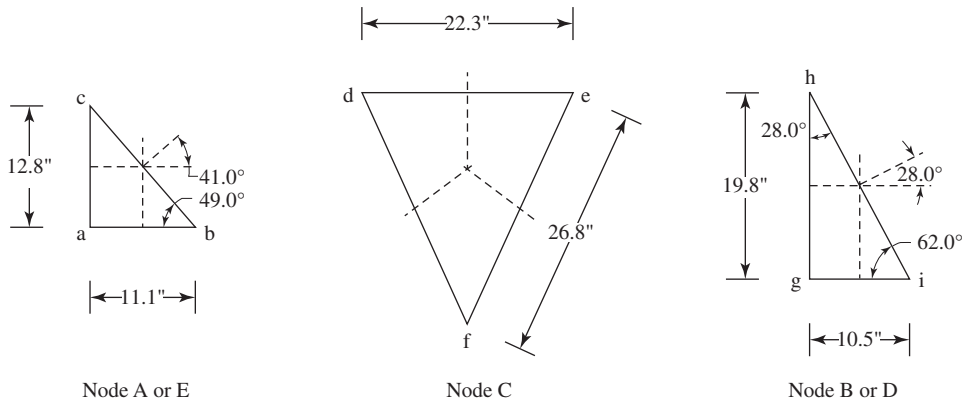
Horizontal Bars below opening

Vertical Bars above opening

Horizontal Bars above opening



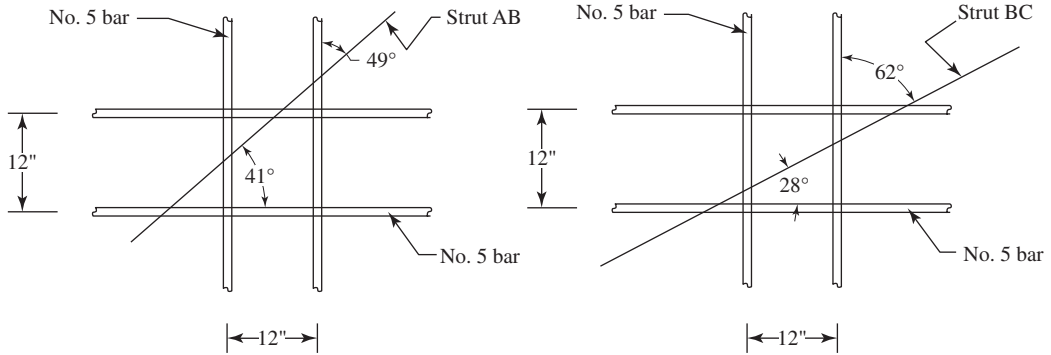
**Figure 8.23** Example 8.4: Strut and Tie model for idealized deep beam with an opening.



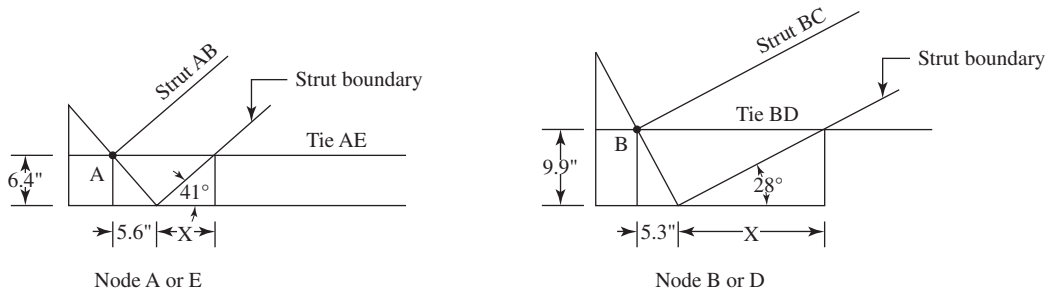
**Figure 8.24** Example 8.4: Nodal zones.

**Table 8.1** Element Forces for Truss Shown in Figure 8.23

Member	Length	P
Identification	<i>in.</i>	<i>Kip</i>
AB	63	-551.06
BC	40	-919.23
CD	40	-919.23
DE	63	-551.1
AE	162	396.21
BD	72	439.43



**Figure 8.25** Example 8.4: Horizontal and vertical reinforcement.



**Figure 8.26** Example 8.4: Node zone at A or E and B or D.

Design Ties:

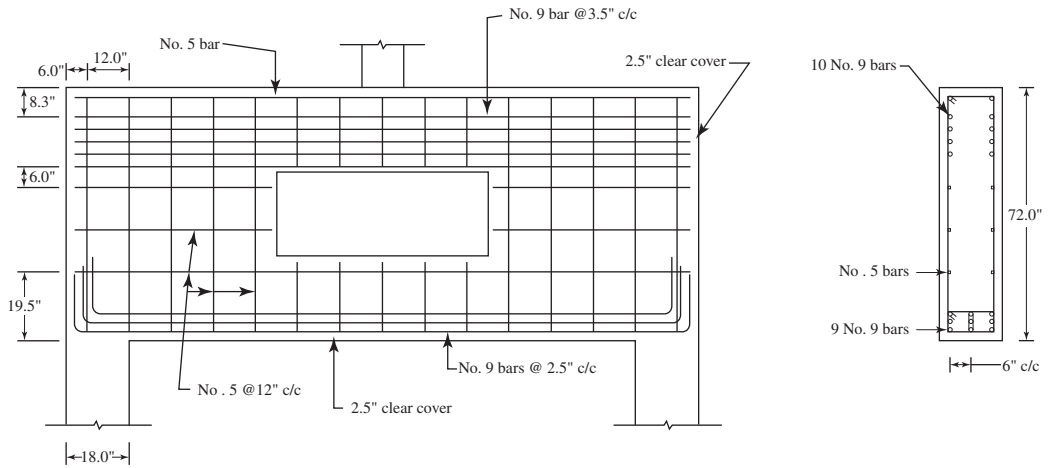
Calculate anchorage length

Development length of No. 9 tension bar with clear spacing not less than  $2d_b$  and clear cover not less than  $d_b$ . Therefore, according to ACI Code, Section 25.4

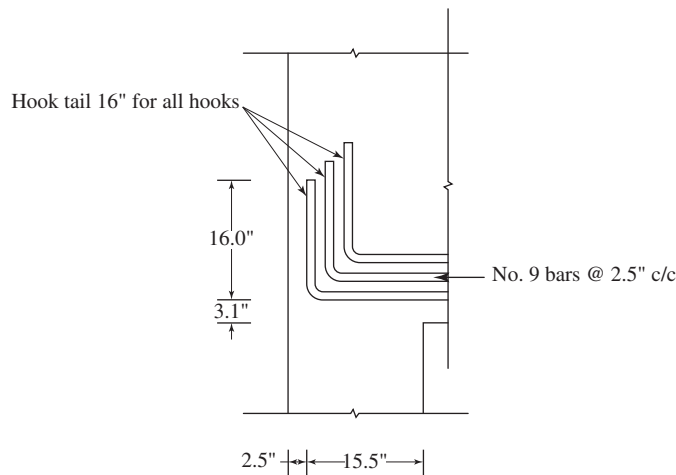
Tie AE (Figure 8.26)

ACI Code, Section 25.4.3.2 if cover is 2.5 in. or greater  $l_{dh}$  can be factored by 0.7

Tie BD (Figure 8.26)



**Figure 8.27** Example 8.4: Reinforcement details.



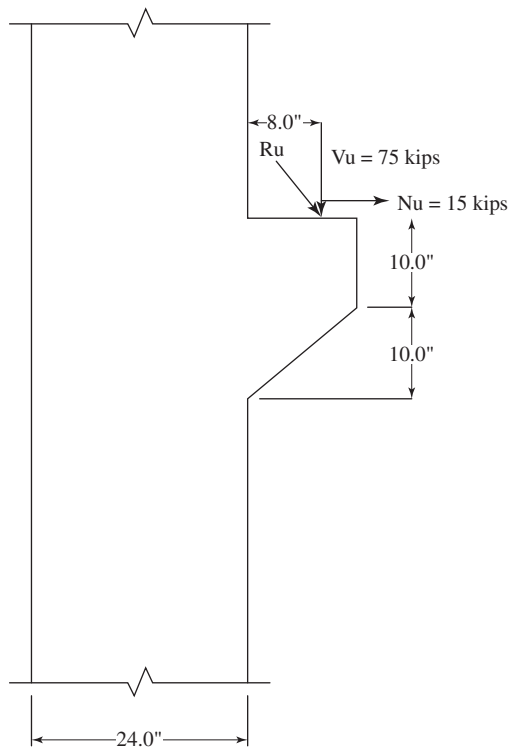
**Figure 8.28** Example 8.4: Hook details.

## REFERENCES

1. American Concrete Institute (ACI). "Building Code Requirements for Structural Concrete." ACI Code 318-14. ACI, Detroit, MI, 2014.
2. American Association of State Highway and Transportation Officials (AASHTO). *AASHTO LRFD Bridge Design Specifications*, 7th ed. AASHTO, Washington, DC, 2014.
3. A. E. Naaman. *Prestressed Concrete Analysis and Design: Fundamentals*, 3rd ed. Techno Press 3000, Ann Arbor, MI, 2012, Chapter 15.

## PROBLEMS

- 8.1** Design the single corbel shown in figure 8.29 on a 24 in.  $\times$  24 in. concrete column with the forces shown. Assume  $f'_c = 6000$  psi, and Grade 60 steel
- 8.2** Design the bridge bent cap shown in figure 8.30 to carry two train tracks and five girders spanning between abutments, with the factored loads and geometry given below. The cap has a width of  $b = 6$  ft and height of  $h = 7$  ft, supported by two 6-ft-wide columns. Design the cap using  $f'_c = 5000$  psi and  $f_y = 60,000$  psi.
- 8.3** Design a simply supported deep beam with two openings shown in figure 8.31, carries two concentrated live service loads of 95 K. The beam has a clear span of 10 ft, overall depth of 40 in. and width of 12 in. The beam is supported on 16-in.-wide columns. Given  $f'_c = 4$  ksi,  $f_y = 60$  ksi, and  $E_s = 29 \times 10^6$  psi. Assume bearing pads at supports and loading points are 16 in.  $\times$  20 in. and 12 in.  $\times$  20 in., respectively.



**Figure 8.29** Corbel on a Column Cap.

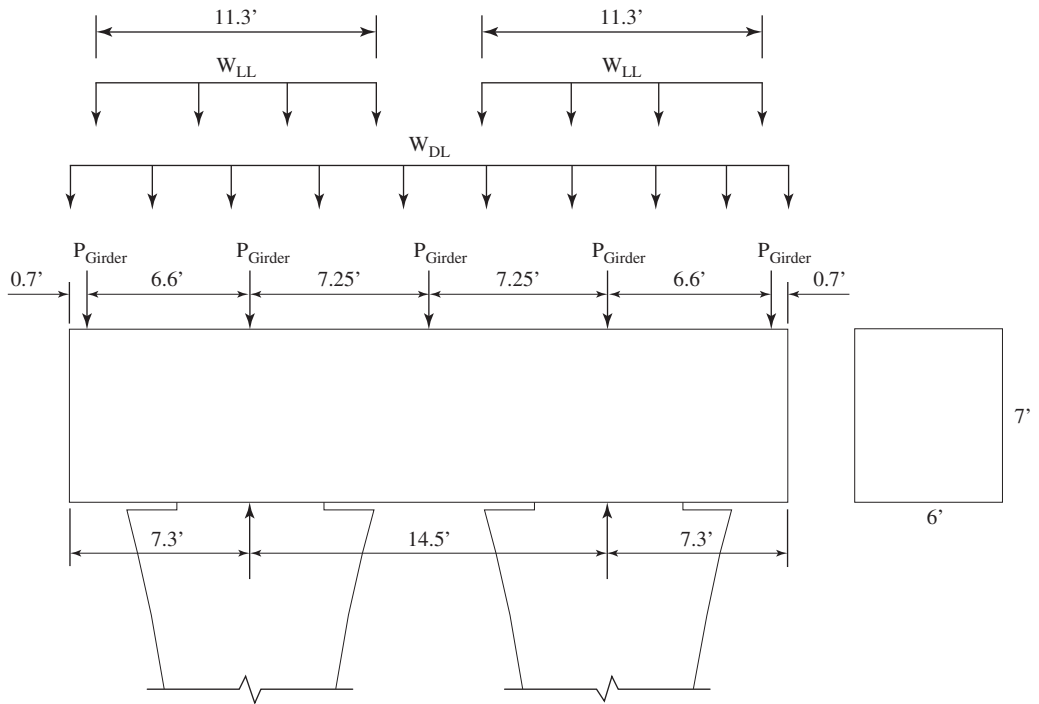


Figure 8.30 Bridge Bent Cap.

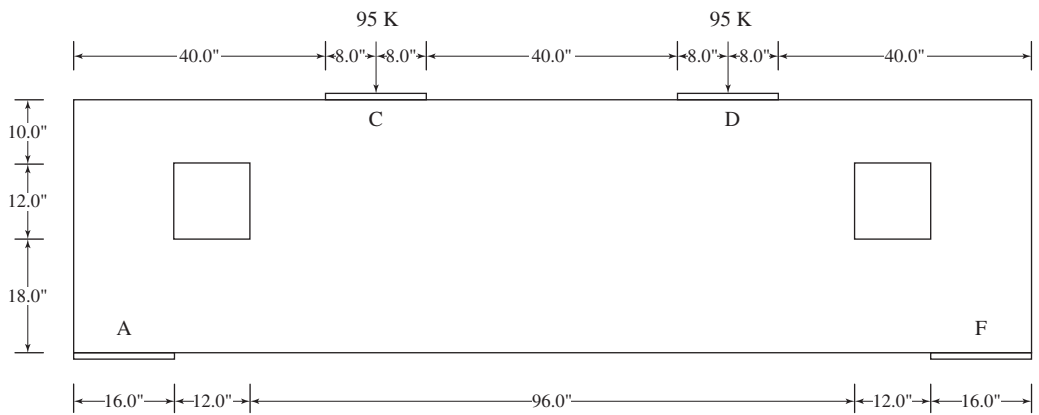


Figure 8.31 Deep Beam with Two Openings.

# CHAPTER 9

## ONE-WAY SLABS



The Westin Hotel, Toronto, Canada.

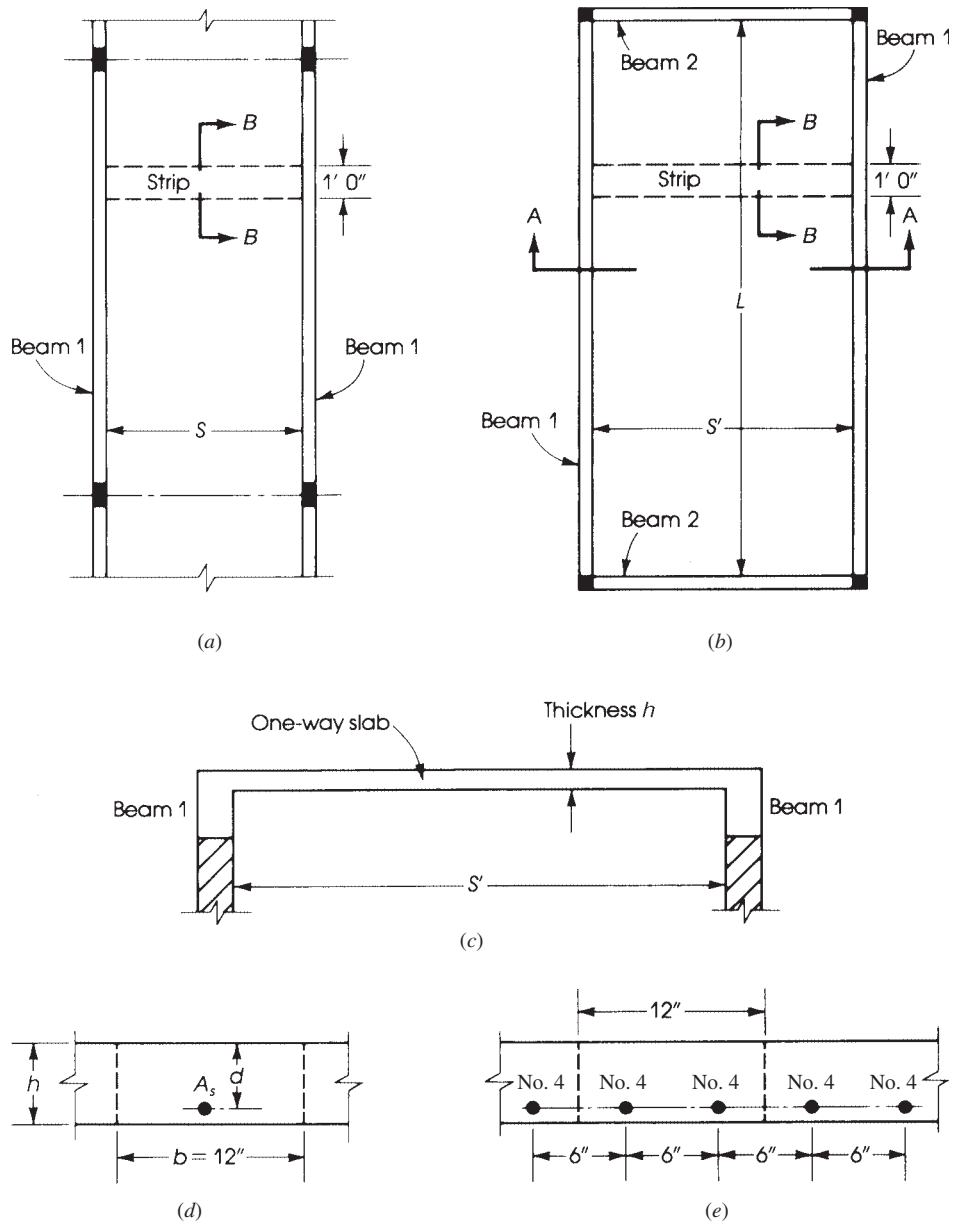
### 9.1 TYPES OF SLABS

Structural concrete slabs are constructed to provide flat surfaces, usually horizontal, in building floors, roofs, bridges, and other types of structures. The slab may be supported by walls, by reinforced concrete beams usually cast monolithically with the slab, by structural steel beams, by columns, or by the ground. The depth of a slab is usually very small compared to its span. See Fig. 9.1.

Structural concrete slabs in buildings may be classified as follows:

1. *One-way slabs*: If a slab is supported on two opposite sides only, it will bend or deflect in a direction perpendicular to the supported edges. The structural action is one way, and the loads are carried by the slab in the deflected short direction. This type of slab is called a *one-way slab* (Fig. 9.1a). If the slab is supported on four sides and the ratio of the long side to the short side is equal to or greater than 2, most of the load (about 95% or more) is carried in the short direction, and one-way action is considered for all practical purposes (Fig. 9.1b). If the slab is made of reinforced concrete with no voids, then it is called a *one-way solid slab*. Figure 9.1c, *d*, and *e* show cross sections and bar distribution.
2. *One-way joist floor system*: This type of slab is also called a *ribbed slab*. It consists of a floor slab, usually 2 to 4 in. (50 to 100 mm) thick, supported by reinforced concrete ribs (or joists). The ribs are usually tapered and are uniformly spaced at distances that do not exceed 30 in. (750 mm). The ribs are supported on girders that rest on columns. The spaces between the ribs may be formed using removable steel or fiberglass form fillers (pans), which may be

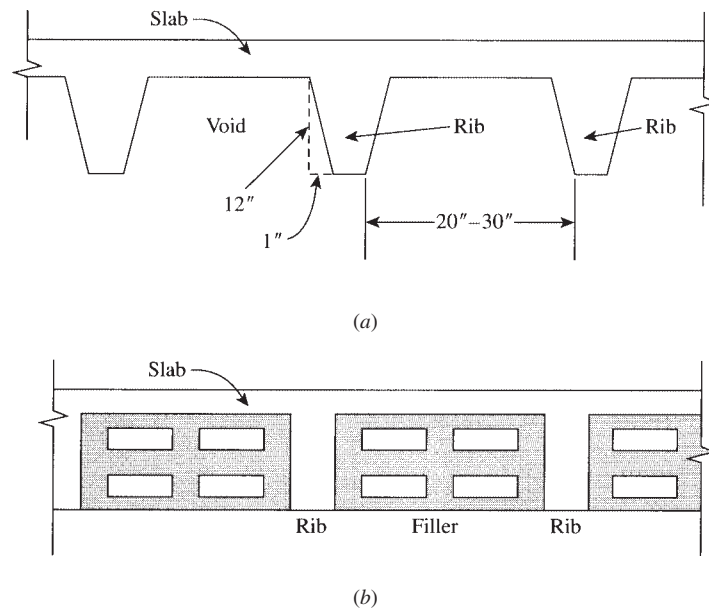




**Figure 9.1** One-way slabs.

used many times (Fig. 9.2). In some ribbed slabs, the spaces between ribs may be filled with permanent fillers to provide a horizontal slab.

3. *Two-way floor systems*: When the slab is supported on four sides and the ratio of the long side to the short side is less than 2, the slab will deflect in double curvature in both directions. The floor load is carried in two directions to the four beams surrounding the slab (refer to



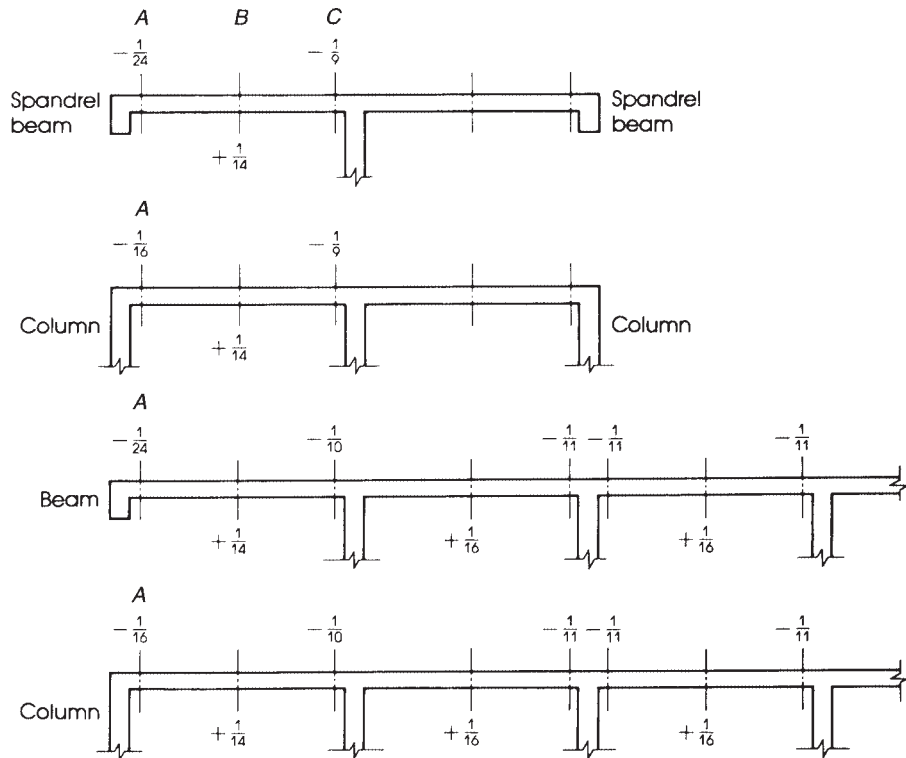
**Figure 9.2** Cross sections of one-way ribbed slab: (a) without fillers and (b) with fillers.

Chapter 17). Other types of *two-way floor systems* are flat plate floors, flat slabs, and waffle slabs, all explained in Chapter 17. This chapter deals only with one-way floor systems.

## 9.2 DESIGN OF ONE-WAY SOLID SLABS

If the concrete slab is cast in one uniform thickness without any type of voids, it can be referred to as a *solid slab*. In a one-way slab, the ratio of the length of the slab to its width is greater than 2. Nearly all the loading is transferred in the short direction, and the slab may be treated as a beam. A unit strip of slab, usually 1 ft (or 1 m) at right angles to the supporting girders, is considered a rectangular beam. The beam has a unit width with a depth equal to the thickness of the slab and a span length equal to the distance between the supports. A one-way slab thus consists of a series of rectangular beams placed side by side (Fig. 9.1).

If the slab is one span only and rests freely on its supports, the maximum positive moment  $M$  for a uniformly distributed load of  $w$  psf is  $M = (wL^2)/8$ , where  $L$  is the span length between the supports. If the same slab is built monolithically with the supporting beams or is continuous over several supports, the positive and negative moments are calculated either by structural analysis or by moment coefficients as for continuous beams. The ACI Code, Section 6.5, permits the use of moment and shear coefficients for prismatic members in the case of two or more approximately equal spans (Fig. 9.3). This condition is met when the larger of two adjacent spans does not exceed the shorter span by more than 20%. For uniformly distributed loads, the unit live load shall not exceed three times the unit dead load. When these conditions are not satisfied, structural analysis is required. In structural analysis, the negative bending moments at the centers of the supports are calculated. The value that may be considered in the design is the negative moment at the face of the support. To obtain this value, subtract from the maximum moment value at the center of the



**Figure 9.3** Moment coefficients for continuous beams and slabs (ACI Code, Section 6.5).

support a quantity equal to  $Vb/3$ , where  $V$  is the shearing force calculated from the analysis and  $b$  is the width of the support:

$$M_f \text{ (at face of support)} = M_c \text{ (at centerline of support)} - \frac{Vb}{3} \quad (9.1)$$

In addition to moment, diagonal tension and development length of bars should also be checked for proper design.

The conditions under which the moment coefficients for continuous beams and slabs, given in Fig. 9.3, should be used can be summarized as follows:

1. Spans are approximately equal: Longer span  $\leq 1.2$  (shorter span).
2. Loads are uniformly distributed.
3. The ratio (live load/dead load) is less than or equal to 3.
4. For slabs with spans less than or equal to 10 ft, negative bending moment at face of all supports is  $\left(\frac{1}{12}\right) w_u l_n^2$ .
5. For an unrestrained discontinuous end at A, the coefficient is 0 at A and  $+\frac{1}{11}$  at B.
6. Shearing force at C is  $1.15w_u l_n/2$  and at the face of all other support is  $\frac{1}{2}w_u l_n$ .
7.  $M_u = (\text{coefficient}) (w_u l_n^2)$  and  $l_n = \text{clear span}$ .

### 9.3 DESIGN LIMITATIONS ACCORDING TO ACI CODE

The following limitations are specified by the ACI Code:

1. A typical imaginary strip 1 ft (or 1 m) wide is assumed.
2. The minimum thickness of one-way slabs using grade 60 steel according to the ACI Code, Sections 7.3.1.1, for solid slabs and for beams or ribbed one-way slabs should be equal to the following:
  - For simply supported spans: solid slabs,  $h = L/20$  (ribbed slabs,  $h = L/16$ ).
  - For one-end continuous spans: solid slabs,  $h = L/24$  (ribbed slabs,  $h = L/18.5$ ).
  - For both-end continuous spans: solid slabs,  $h = L/28$  (ribbed slabs,  $h = L/21$ ).
  - For cantilever spans: solid slabs,  $h = L/10$  (ribbed slabs,  $h = L/8$ ).
  - For  $f_y$  other than 60 ksi, these values shall be multiplied by  $(0.4 + 0.01f_y)$ , where  $f_y$  is in ksi. This minimum thickness should be used unless computation of deflection indicates a lesser thickness can be used without adverse effects.
3. Deflection is to be checked when the slab supports are attached to construction likely to be damaged by large deflections. Deflection limits are set by the ACI Code, Table 24.2.2.
4. It is preferable to choose slab depth to the nearest  $\frac{1}{2}$  in. (or 10 mm).
5. Shear should be checked, although it does not usually control.
6. Concrete cover in slabs shall not be less than  $\frac{3}{4}$  in. (20 mm) at surfaces not exposed to weather or ground. In this case,  $d = h - \left(\frac{3}{4} \text{ in.}\right) - (\text{half} - \text{bar diameter})$ . Refer to Fig. 9.1d.
7. In structural one way slabs of uniform thickness, the minimum amount of reinforcement in the direction of the span shall not be less than that required for shrinkage and temperature reinforcement (ACI Code, Sections 7.6.1 and 24.4.3).
8. The main reinforcement maximum spacing shall be the lesser of three times the slab thickness and 18 in. (ACI Code, Section 7.7.2.3).
9. Straight-bar systems may be used in both tops and bottoms of continuous slabs. An alternative bar system of straight and bent (trussed) bars placed alternately may also be used. Bars may also be placed at the center of the slab using a lesser effective depth but accounting for the highest moments.
10. In addition to main reinforcement, steel bars at right angles to the main must be provided. This additional steel is called *secondary, distribution, shrinkage, or temperature reinforcement*.

### 9.4 TEMPERATURE AND SHRINKAGE REINFORCEMENT

Concrete shrinks as the cement paste hardens, and a certain amount of shrinkage is usually anticipated. If a slab is left to move freely on its supports, it can contract to accommodate the shrinkage. However, slabs and other members are joined rigidly to other parts of the structure, causing a certain degree of restraint at the ends. This results in tension stresses known as *shrinkage stresses*. A decrease in temperature and shrinkage stresses is likely to cause hairline cracks. Reinforcement is placed in the slab to counteract contraction and distribute the cracks uniformly. As the concrete shrinks, the steel bars are subjected to compression.

Reinforcement for shrinkage and temperature stresses normal to the principal reinforcement should be provided in a structural slab in which the principal reinforcement extends in one direction

only. The ACI Code, Sections 7.6.1, 8.6.1, and 24.4.3, specifies the following minimum steel ratios: For slabs in which grade 40 or 50 deformed bars are used,  $\rho = 0.2\%$ , and for slabs in which grade 60 deformed bars or welded bars or welded wire fabric are used,  $\rho = 0.18\%$ . In no case shall such reinforcement be placed farther apart than five times the slab thickness or more than 18 in.

For temperature and shrinkage reinforcement, the whole concrete depth  $h$  exposed to shrinkage shall be used to calculate the steel area. For example, if a slab has a total depth of  $h = 6$  in. and  $f_y = 60$  ksi, then the area of steel required per 1-ft width of slab is  $A_s = 6(12)(0.0018) = 0.129$  in.<sup>2</sup>. The spacings of the bars,  $S$ , can be determined as follows:

$$S = \frac{12A_b}{A_s} \quad (9.2)$$

where  $A_b$  is the area of the bar chosen and  $A_s$  the calculated area of steel.

For example, if no. 3 bars are used ( $A_b = 0.11$  in.<sup>2</sup>), then  $S = 12(0.11)/0.129 = 10.33$  in., say, 10 in. If no. 4 bars are chosen ( $A_b = 0.2$  in.<sup>2</sup>), then  $S = 12(0.2)/0.129 = 18.6$  in., say, 18 in. Maximum spacing is the smaller of five times slab thickness (30 in.) or 18 in. Then no. 4 bars spaced at 18 in. are adequate (or no. 3 bars at 10 in.). These bars act as secondary reinforcement and are placed normal to the main reinforcement calculated by flexural analysis. Note that areas of bars in slabs are given in Table A.14.

## 9.5 REINFORCEMENT DETAILS

In continuous one-way slabs, the steel area of the main reinforcement is calculated for all critical sections, at midspans, and at supports. The choice of bar diameter and detailing depends mainly on the steel areas, spacing requirements, and development length. Two bar systems may be adopted.

In the straight-bar system (Fig. 9.4), straight bars are used for top and bottom reinforcement in all spans. The time and cost to produce straight bars is less than that required to produce bent bars; thus, the straight-bar system is widely used in construction.

In the bent-bar, or trussed, system, straight and bent bars are placed alternately in the floor slab. The location of bent points should be checked for flexural, shear, and development length requirements. For normal loading in buildings, the bar details at the end and interior spans of one-way solid slabs may be adopted as shown in Fig. 9.4.

## 9.6 DISTRIBUTION OF LOADS FROM ONE-WAY SLABS TO SUPPORTING BEAMS

In one-way floor slab systems, the loads from slabs are transferred to the supporting beams along the long ends of the slabs. The beams transfer their loads in turn to the supporting columns.

From Fig. 9.5 it can be seen that beam  $B_2$  carries loads from two adjacent slabs. Considering a 1-ft length of beam, the load transferred to the beam is equal to the area of a strip 1 ft wide and  $S$  feet in length multiplied by the intensity of load on the slab.

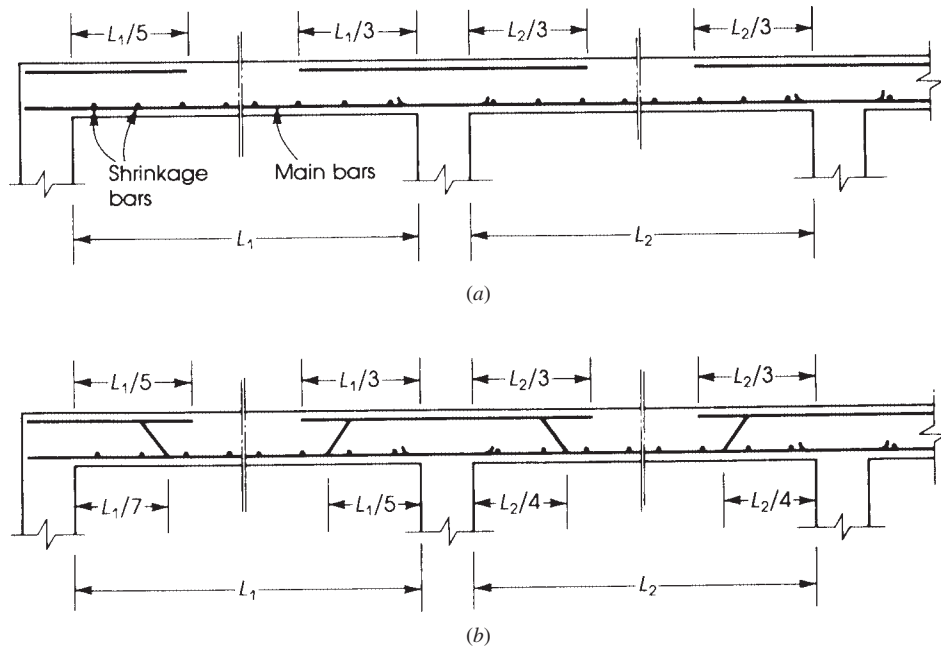
This load produces a uniformly distributed load on the beam:

$$U_B = U_S S$$

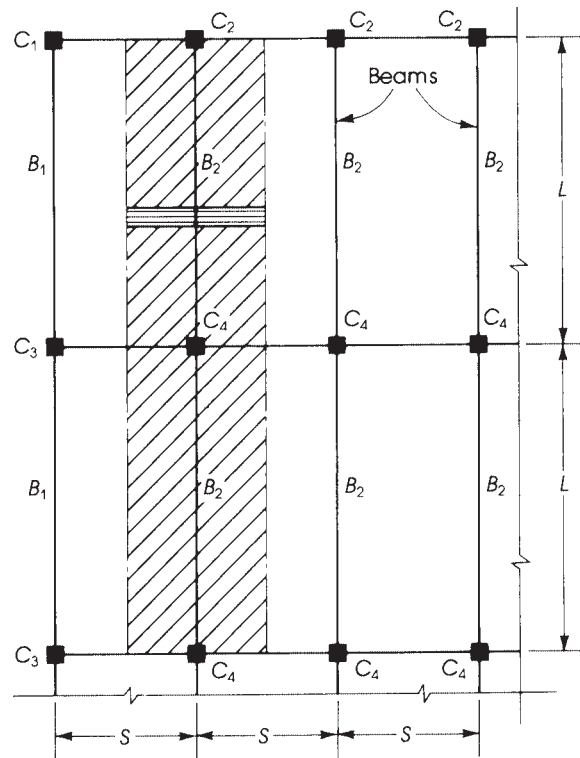
The uniform load on the end beam,  $B_1$ , is half the load on  $B_2$  because it supports a slab from one side only.

The load on column  $C_4$  is equal to the reactions from two adjacent  $B_2$  beams:

$$\text{Load on column } C_4 = U_B L = U_S L S$$



**Figure 9.4** Reinforcement details in continuous one-way slabs: (a) straight bars and (b) bent bars.



**Figure 9.5** Distribution of loads on beams.

The load on column  $C_3$  is one-half the load on column  $C_4$  because it supports loads from slabs on one side only. Similarly, the loads on columns  $C_2$  and  $C_1$  are

$$\text{Load on } C_2 = U_S \frac{L}{2} S = \text{load on } C_3$$

$$\text{Load on } C_1 = U_S \left( \frac{L}{2} \right) \left( \frac{S}{2} \right)$$

From this analysis, it can be seen that each column carries loads from slabs surrounding the column and up to the centerline of adjacent slabs: up to  $L/2$  in the long direction and  $S/2$  in the short direction.

Distribution of loads from two-way slabs to their supporting beams and columns is discussed in Chapter 17.

### Example 9.1

Calculate the design moment strength of a one-way solid slab that has a total depth of  $h = 7$  in. and is reinforced with no. 6 bars spaced at  $S = 7$  in. Use  $f'_c = 3$  ksi and  $f_y = 60$  ksi.

#### Solution

1. Determine the effective depth,  $d$ :

$$d = h - \frac{3}{4} \text{ in. (cover)} - \text{half - bar diameter} \quad (\text{See Fig. 9.1d})$$

$$d = 7 - \frac{3}{4} - \frac{6}{16} = 5.875 \text{ in.}$$

2. Determine the average  $A_s$  provided per 1-ft width (12 in.) of slab. The area of a no. 6 bar is  $A_b = 0.44 \text{ in}^2$ .

$$A_s = \frac{12A_b}{S} = \frac{12(0.44)}{7} = 0.754 \text{ in}^2/\text{ft}$$

Areas of bars in slabs are given in Table A.14 in Appendix A.

3. Compare the steel ratio used with  $\rho_{\max}$  and  $\rho_{\min}$ . For  $f'_c = 3$  ksi and  $f_y = 60$  ksi,  $\rho_{\max} = 0.01356$  and  $\rho_{\min} = 0.00333$ , where  $\rho$  (used)  $= 0.754/(12 \times 5.875) = 0.0107$ , which is adequate ( $\phi = 0.9$ ).
4. Calculate  $\phi$ :

$$a = A_s f_y / (0.85 f'_c b) = 0.754(60) / (0.85 \times 3 \times 12) = 1.48 \text{ in.}$$

$$\phi M_n = 0.9(0.754)(60)(5.875 - 1.48/2) = 209 \text{ K} \cdot \text{in.} = 17.42 \text{ K} \cdot \text{ft}$$

### Example 9.2

Determine the allowable uniform live load that can be applied on the slab of the previous example if the slab span is 16 ft between simple supports and carries a uniform dead load (excluding self-weight) of 100 psf.

#### Solution

1. The design moment strength of the slab is 17.42 K ft per 1-ft width of slab.

$$M_u = \phi M_n = 17.42 = \frac{W_u L^2}{8} = \frac{W_u (16)^2}{8}$$

The factored uniform load is  $W_u = 0.544 \text{ K/ft}^2 = 544 \text{ psf}$ .

$$2. \quad W_u = 1.2D + 1.6L$$

$$D = 100 \text{ psf} + \text{self-weight} = 100 + \frac{7}{12}(150) = 187.5 \text{ psf}$$

$$544 = 1.2(187.5) + 1.6L \quad L = 200 \text{ psf}$$

**Example 9.3**

Design a 12-ft simply supported slab to carry a uniform dead load (excluding self-weight) of 120 psf and a uniform live load of 100 psf. Use  $f'_c = 3$  ksi,  $f_y = 60$  ksi,  $\lambda = 1$ , and the ACI Code limitations.

**Solution**

1. Assume a slab thickness. For  $f_y = 60$  ksi, the minimum depth to control deflection is  $L/20 = 12(12)/20 = 7$  in. Assume a total depth of  $h = 7$  in. and assume  $d = 6$  in. (to be checked later).

2. Calculate factored load: weight of slab =  $\frac{7}{12}(150) = 87.5$  psf

$$W_u = 1.2D + 1.6L = 1.2(87.5 + 120) + 1.6(100) = 409 \text{ psf}$$

For a 1-ft width of slab,  $M_u = W_u L^2 / 8$ .

$$M_u = \frac{0.409(12)^2}{8} = 7.362 \text{ K} \cdot \text{ft}$$

3. Calculate  $A_s$ : For  $M_u = 7.362 \text{ K} \cdot \text{ft}$ ,  $b = 12$  in., and  $d = 6$  in.,  $R_u = M_u / bd^2 = 7.362(12,000) / (12)(6)^2 = 205$  psi. From tables in Appendix A,  $\rho = 0.0040 < \rho_{\max} = 0.01356$ ,  $\phi = 0.9$ .

$$A_s = \rho bd = 0.0040(12)(6) = 0.28 \text{ in.}^2$$

Choosing no. 4 bars ( $A_b = 0.2 \text{ in.}^2$ ), and  $S = 12A_b / A_s = 12(0.2) / 0.28 = 8.6$  in. Check actual  $d = h - \frac{3}{4} - \frac{4}{16} = 6$  in. It is acceptable. Let  $S = 8$  in. and  $A_s = 0.3 \text{ in.}^2$ .

4. Check the moment capacity of the final section.

$$a = \frac{A_s f_y}{0.85 f'_c b} = \frac{0.3(60)}{0.85 \times 3 \times 12} = 0.59 \text{ in.}$$

$$\phi M_n = \phi A_s f_y \left( d - \frac{a}{2} \right) = 0.9(0.3)(60) \left( 6 - 0.59/2 \right) = 92.42 \text{ K} \cdot \text{in.} = 7.7 \text{ K} \cdot \text{ft} > M_u$$

$$= 7.362 \text{ K} \cdot \text{ft}$$

5. Calculate the secondary (shrinkage) reinforcement normal to the main steel. For  $f_y = 60$  ksi,

$$\rho_{\min} = 0.0018$$

$$A_{\text{sh}} = \rho_{\min} bh = 0.0018(12)(7) = 0.1512 \text{ in.}^2$$

Choose no. 4 bars,  $A_b = 0.2 \text{ in.}^2$ ,  $S = 12A_b / A_s = 12(0.2) / 0.1512 = 15.9$  in. Use no. 4 bars spaced at 15 in.

6. Check shear requirements:  $V_u$  at a distance  $d$  from the support is  $0.409 \left( \frac{12}{2} - \frac{6}{12} \right) = 2.25 \text{ K}$ .

$$\phi V_c = \frac{\phi 2 \lambda \sqrt{f'_c} b d}{1000} = \frac{0.75(2)(1)(\sqrt{3000})(12 \times 6)}{1000} = 5.9 \text{ K}$$

$$\frac{1}{2} \phi V_c = 2.95 \text{ K} > V_u$$

so the shear is adequate.

7. Final section:  $h = 7$  in., main bars = no. 4 spaced at 8 in., and secondary bars = no. 4 spaced at 15 in.



**Example 9.4**

The cross section of a continuous one-way solid slab in a building is shown in Fig. 9.6. The slabs are supported by beams that span 12 ft between simple supports. The dead load on the slabs is that due to self-weight plus 77 psf; the live load is 130 psf. Design the continuous slab and draw a detailed section. Given:  $f'_c = 3$  ksi and  $f_y = 40$  ksi.

**Solution**

1. The minimum thickness of the first slab is  $L/30$  because one end is continuous and the second end is discontinuous. The distance between centers of beams may be considered the span  $L$ , here equal to 12 ft. For  $f_y = 40$  ksi,

$$\text{Minimum total depth} = \frac{L}{30} = \frac{12 \times 12}{30} = 4.8 \text{ in.}$$

$$\text{Minimum total depth for interior span} = \frac{L}{35} = 4.1 \text{ in.}$$

Assume a uniform thickness of 5 in., which is greater than 4.8 in.; therefore, it is not necessary to check deflection.

2. Calculate loads and moments in a unit strip:

$$\text{Dead load} = \text{weight of slab} + 77 \text{ psf}$$

$$= \left( \frac{5}{12} \times 150 \right) + 77 = 139.5 \text{ psf}$$

$$\text{Factored load } (U) = 1.2D + 1.6L = 1.2 \times 139.5 + 1.6 \times 130 = 375.5 \text{ psf}$$

The clear span is 11.0 ft. The required moment in the first span is over the support and equals  $UL^2/10$ .

$$M_u = \frac{U(11)^2}{10} = (0.3755) \frac{121}{10} = 4.54 \text{ K} \cdot \text{ft} = 54.5 \text{ K} \cdot \text{in.}$$

3. Assume  $\rho = 1.4\%$ ; then  $R_u = 450$  psi = 0.45 ksi. This value is less than  $\rho_{\max}$  of 0.0203 (Table 4.1), and greater than  $\rho_{\min}$  of 0.005 ( $\phi = 0.9$ ).

$$d = \sqrt{\frac{M_u}{R_u b}} = \sqrt{\frac{54.5}{0.45 \times 12}} = 3.18 \text{ in.}$$

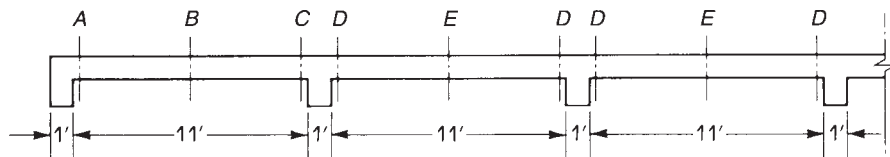
$$A_s = \rho b d = 0.014(12)(3.18) = 0.53 \text{ in.}^2$$

Choosing no. 5 bars,

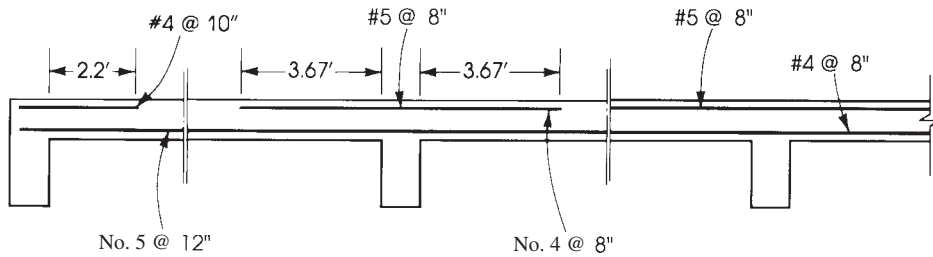
$$\text{Total depth} = d + \frac{1}{2} \text{ bar diameter} + \text{cover} = 3.18 + \frac{5}{16} + \frac{3}{4} = 4.25 \text{ in.}$$

Use slab thickness of 5 in., as assumed earlier.

$$\text{Actual } d \text{ used} = 5 - \frac{3}{4} - \frac{5}{16} = 3.9 \text{ in.}$$



**Figure 9.6** Example 9.4.



**Figure 9.7** Example 9.4: Reinforcement details.

4. Moments and steel reinforcement required at other sections using  $d = 3.9$  in. are as follows:

Location	Moment Coefficient	$M_u$ (K · in.)	$R_u = M_u/bd^2$ (psi)	$\rho$ (%)	$A_s$ (in. <sup>2</sup> )	Bars and Spacings
A	$-\frac{1}{24}$	22.7	Small	0.50	0.23	No. 4 at 10 in.
B	$+\frac{1}{14}$	38.9	213	0.65	0.30	No. 5 at 12 in.
C	$-\frac{1}{10}$	54.5	300	0.90	0.44	No. 5 at 8 in.
D	$-\frac{1}{11}$	49.6	271	0.80	0.38	No. 5 at 8 in.
E	$+\frac{1}{16}$	34.1	187	0.55	0.26	No. 4 at 8 in.

The arrangement of bars is shown in Fig. 9.7.

5. Maximum shear occurs at the exterior face of the second support, section C.

$$V_u(\text{at } C) = \frac{1.15UL_n}{2} = \frac{1.15(0.3755)(11)}{2} = 2.375 \text{ K/ft of width}$$

$$\phi V_c = \phi 2\lambda\sqrt{f'_c} bd = \frac{0.75(2)(1)(\sqrt{3000})(12)(3.9)}{1000} = 3.84 \text{ K}$$

This result is acceptable. Note that the provision of minimum area of shear reinforcement when  $V_u$  exceeds  $\frac{1}{2}\phi V_c$  does not apply to slabs (ACI Code, Section 9.6.3.1).

### Example 9.5

Determine the uniform factored load on an intermediate beam supporting the slabs of Example 9.4. Also calculate the axial load on an interior column; refer to the general plan of Fig. 9.5. Assume the beam span = 24 ft.

#### Solution

1. The uniform factored load per foot length on an intermediate beam is equal to the factored uniform load on slab multiplied by  $S$ , the short dimension of the slab. Therefore,

$$U(\text{beam}) = U(\text{slab}) \times S = 0.3755 \times 12 = 4.5 \text{ K/ft}$$

The weight of the web of the beam shall be added to this value. Span of the beam is 24 ft.

$$\text{Estimated total depth} = \frac{L}{20} \times 0.8 = \left( \frac{24}{20} \times 0.8 \right) \times 12 = 11.5 \text{ in.} \quad \text{say, 12 in.}$$

Slab thickness is 5 in. and height of the web is  $12 - 5 = 7$  in.

$$\text{Factored weight of beam web} = \left( \frac{7}{12} \times 150 \right) \times 1.2 = 105 \text{ lb/ft}$$

$$\text{Total uniform load on beam} = 4.5 + 0.105 = 4.605 \text{ K/ft}$$

2. Axial load on an interior column:

$$P_u = 4.605 \times 24 \text{ ft} = 110.5 \text{ K}$$


---

## 9.7 ONE-WAY JOIST FLOOR SYSTEM

A one-way joist floor system consists of hollow slabs with a total depth greater than that of solid slabs. The system is most economical for buildings where superimposed loads are small and spans are relatively large, such as schools, hospitals, and hotels. The concrete in the tension zone is ineffective; therefore, this area is left open between ribs or filled with lightweight material to reduce the self-weight of the slab.

The design procedure and requirements of ribbed slabs follow the same steps as those for rectangular and T-sections explained in Chapter 3. The following points apply to design of one-way ribbed slabs:

1. Ribs are usually tapered and uniformly spaced at about 16 to 30 in. (400 to 750 mm). Voids are usually formed by using pans (molds) 20 in. (500 mm) wide and 6 to 20 in. (150 to 500 mm) deep, depending on the design requirement. The standard increment in depth is 2 in. (50 mm).
2. The ribs shall not be less than 4 in. (100 mm) wide and must have a depth of not more than 3.5 times the width. Clear spacing between ribs shall not exceed 30 in. (750 mm) (ACI Code, Section 9.8.1).
3. Shear strength,  $V_c$ , provided by concrete for the ribs may be taken 10% greater than that for beams. This is mainly due to the interaction between the slab and the closely spaced ribs (ACI Code, Section 9.8.1.5).
4. The thickness of the slab on top of the ribs is usually 2 to 4 in. (50 to 100 mm) and contains minimum reinforcement (shrinkage reinforcement). This thickness shall not be less than  $\frac{1}{12}$  of the clear span between ribs or 1.5 in. (38 mm) (ACI Code, Section 9.8.2.1.1).
5. The ACI coefficients for calculating moments in continuous slabs can be used for continuous ribbed slab design.
6. There are additional practice limitations, which can be summarized as follows:
  - The minimum width of the rib is one-third of the total depth or 4 in. (100 mm), whichever is greater.
  - Secondary reinforcement in the slab in the transverse directions of ribs should not be less than the shrinkage reinforcement or one-fifth of the area of the main reinforcement in the ribs.
  - Secondary reinforcement parallel to the ribs shall be placed in the slab and spaced at distances not more than half of the spacings between ribs.

- If the live load on the ribbed slab is less than  $3 \text{ kN/m}^2$  (60 psf) and the span of ribs exceeds 5 m (17 ft), a secondary transverse rib should be provided at midspan (its direction is perpendicular to the direction of main ribs) and reinforced with the same amount of steel as the main ribs. Its top reinforcement shall not be less than half of the main reinforcement in the tension zone. These transverse ribs act as floor stiffeners.
- If the live load exceeds  $3 \text{ kN/m}^2$  (60 psf) and the span of ribs varies between 4 and 7 m (13 and 23 ft), one transverse rib must be provided, as indicated before. If the span exceeds 7 m (23 ft), at least two transverse ribs at one-third span must be provided with reinforcement, as explained before.

### Example 9.6

Design an interior rib of a concrete joist floor system with the following description: Span of rib = 20 ft (simply supported), dead load (excluding own weight) = 16 psf, live load = 85 psf,  $f'_c = 4 \text{ ksi}$ , and  $f_y = 60 \text{ ksi}$ .

#### Solution

1. Design of the slab: Assume a top slab thickness of 2 in. that is fixed to ribs that have a clear spacing of 20 in. No fillers are used. The self-weight of the slab is  $\frac{2}{12} \times 150 = 25 \text{ psf}$ .

$$\text{Total DL} = 16 + 25 = 41 \text{ psf}$$

$$U = 1.2D + 1.6L = 1.2 \times 41 + 1.6 \times 85 = 185 \text{ psf}$$

$$\begin{aligned} M_u &= \frac{UL^2}{12} \quad (\text{Slab is assumed fixed to ribs.}) \\ &= \frac{0.185}{12} \left( \frac{20}{12} \right)^2 = 0.043 \text{ K} \cdot \text{ft} = 0.514 \text{ K} \cdot \text{in.} \end{aligned}$$

Considering that the moment in slab will be carried by plain concrete only, the allowable flexural tensile strength is  $f_t = 5\sqrt{f'_c}$ , with a capacity reduction factor  $\phi = 0.55$ ,  $f_t = 5\sqrt{4000} = 316 \text{ psi}$ .

$$\text{Flexural tensile strength} = \frac{Mc}{I} = \phi f_t$$

where

$$I = \frac{bh^3}{12} = \frac{12(2)^3}{12} = 8 \text{ in.}^4 \quad c = \frac{h}{2} = \frac{2}{2} = 1 \text{ in.}$$

$$M = \phi f_t \frac{I}{c} = 0.55 \times 0.316 \times \frac{8}{1} = 1.39 \text{ K} \cdot \text{in.}$$

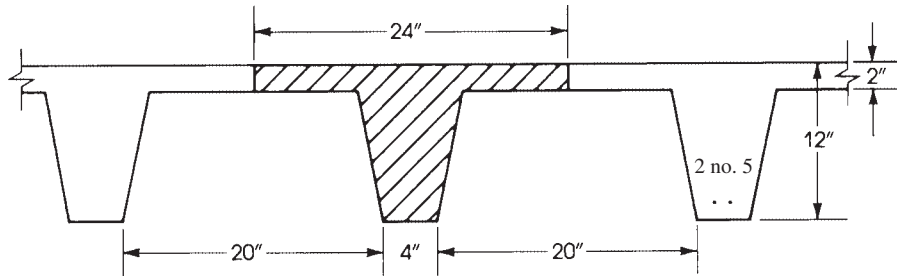
This value is greater than  $M_u = 0.514 \text{ K} \cdot \text{in.}$ , and the slab is adequate. For shrinkage reinforcement,  $A_s = 0.0018 \times 12 \times 2 = 0.043 \text{ in.}^2$  Use no. 3 bars spaced at 12 in. laid transverse to the direction of the ribs. Welded wire fabric may be economically used for this low amount of steel reinforcement. Use similar shrinkage reinforcement no. 3 bars spaced at 12 in. laid parallel to the direction of ribs, one bar on top of each rib and one bar in the slab between ribs.

2. Calculate moment in a typical rib:

$$\text{Minimum depth} = \frac{L}{20} = \frac{20 \times 12}{20} = 12 \text{ in.}$$

The total depth of rib and slab is  $10 + 2 = 12 \text{ in.}$  Assume a rib width of 4 in. at the lower end that tapers to 6 in. at the level of the slab (Fig. 9.8). The average width is 5 in. Note that the increase in the rib width using removable forms has a ratio of about 1 horizontal to 12 vertical.

$$\text{Weight of rib} = \frac{5}{12} \times \frac{10}{12} \times 150 = 52 \text{ lb/ft}$$

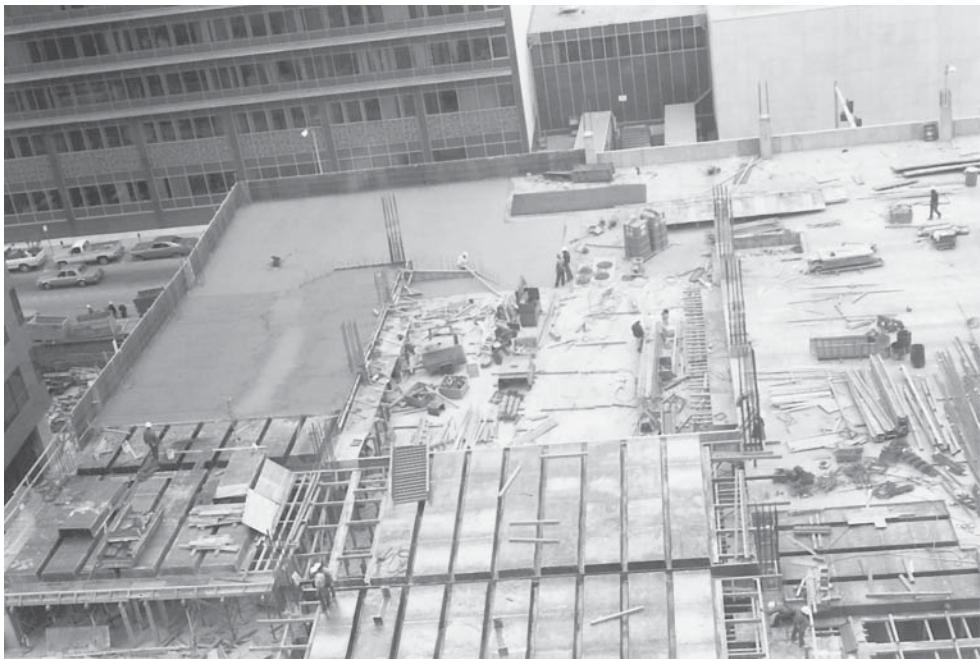


**Figure 9.8** Example 9.6.

The rib carries a load from (20 + 4)-in.-wide slab plus its own weight:

$$U = \frac{24}{12} \times 185 + (1.2 \times 52) = 432.4 \text{ lb/ft}$$

$$M_u = \frac{UL^2}{8} = \frac{0.4324}{8} (20)^2 \times 12 = 259.4 \text{ K} \cdot \text{in.}$$



Rectangular steel pans used in one-way ribbed slab construction.

3. Design of rib: The total depth is 12 in. Assuming no. 5 bars and concrete cover of  $\frac{3}{4}$  in., the effective depth  $d$  is  $12 - \frac{3}{4} - \frac{5}{16} = 10.9$  in. Check the moment capacity of the flange (assume tension-controlled section,  $\phi = 0.9$ ):

$$\phi M_n(\text{flange}) = \phi C \left( d - \frac{t}{2} \right) \quad \text{where } C = 0.85 f'_c b t$$

$$M_u = 0.9(0.85 \times 4 \times 24 \times 2) \left( 10.9 - \frac{2}{2} \right) = 1454 \text{ K} \cdot \text{in.}$$

The moment capacity of the flange is greater than the applied moment; thus, the rib acts as a rectangular section with  $b = 24$  in., and the depth of the equivalent compressive block  $a$  is less than 2 in.

$$\phi M_n = \phi A_s f_y \left( d - \frac{a}{2} \right) = \phi A_s f_y \left( d - \frac{A_s f_y}{1.7 f'_c b} \right)$$

$$259.4 = 0.9 A_s \times 60 \left( 10.9 - \frac{A_s \times 60}{1.7 \times 4 \times 24} \right) \quad A_s = 0.45 \text{ in.}^2$$

$$a = \frac{A_s f_y}{0.85 \times f'_c b} = 0.33 \text{ in.} < 2 \text{ in.}$$

Use two no. 5 bars per rib ( $A_s = 0.65 \text{ in.}^2$ ).

$$A_{s \min} = 0.0033 b_w d = 0.0033(5)(10.9) = 0.18 \text{ in.}^2 < 0.45 \text{ in.}^2$$

Check

$$\rho = \frac{0.45}{24 \times 10.9} = 0.00172 < \rho_{\max} = 0.01806$$

which is a tension-controlled section,  $\phi = 0.9$ .

4. Calculate shear in the rib: The allowable shear strength of the rib web is

$$\phi V_c = \phi(1.1) \times 2\lambda \sqrt{f'_c} b_w d$$

$$= 0.75 \times 1.1 \times 2(1) \sqrt{4000} \times 5 \times 10.9 = 5687 \text{ lb}$$

The factored shear at a distance  $d$  from the support is

$$V_u = 432.4 \left( 10 - \frac{10.9}{12} \right) = 3931 \text{ lb}$$

This is less than the shear capacity of the rib. Minimum stirrups may be used, and in this case an additional no. 4 bar will be placed within the slab above the rib to hold the stirrups in place. It is advisable to add one transverse rib at midspan perpendicular to the direction of the ribs having the same reinforcement as that of the main ribs to act as a stiffener.

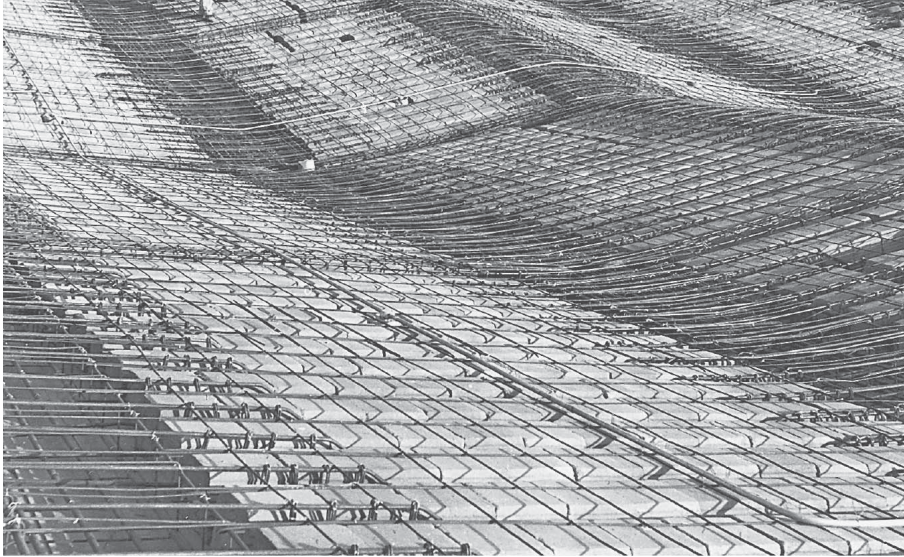
## SUMMARY

### Section 9.1

Slabs are of different types, one way (solid or joist floor systems) and two way (solid, ribbed, waffle, flat slabs, and flat plates).

### Sections 9.2 and 9.3

1. The ACI Code moment and shear coefficients for continuous one-way slabs are given in the accompanying figure.
2. The minimum thickness of one-way slabs using grade 60 steel is  $L/20$ ,  $L/24$ ,  $L/28$ , and  $L/10$  for simply supported, one-end continuous, both-end continuous, and cantilever slabs, respectively.



One-way ribbed slab roof. The wide beams have the same total depth as the ribbed slab.

#### Section 9.4

The minimum shrinkage steel ratios,  $\rho_{\min}$ , in slabs are 0.002 in. for slabs in which grade 40 or grade 50 bars are used and 0.0018 in. for slabs in which deformed bars of grade 60 are used.

Maximum spacings between bars  $\leq 5$  times rib thickness  $\leq 18$  in.

#### Sections 9.5 and 9.6

1. Reinforcement details are shown in Fig. 9.4.
2. Distribution of loads from one-way slabs to the supporting beams is shown in Fig. 9.5.

#### Section 9.7

The design procedure of ribbed slabs is similar to that of rectangular and T-sections. The width of ribs must be greater than or equal to 4 in., whereas the depth must be less than or equal to 3.5 times the width. The minimum thickness of the top slab is 2 in. or not less than one-twelfth of the clear span between ribs.

### REFERENCES

1. Concrete Reinforcing Steel Institute (CRSI). *CRSI Design Handbook*, 10th ed. CRSI, Chicago, IL, 2010.
2. Portland Cement Association (PCA). *Continuity in Concrete Building Frames*. PCA, Chicago, IL, 1959.
3. American Concrete Institute (ACI). *Building Code Requirements for Structural Concrete*. ACI, ACI Code 318–14. Detroit, MI, 2014.

## PROBLEMS

**9.1** For each problem, calculate the factored moment capacity of each concrete slab section using  $f_y = 60$  ksi.

Number	$f'_c$	$h$ (in.)	Bars and Spacings (in.)	Answer $\Phi M_n$ (K · ft)
a	3	5	No. 4 at 6	6.35
b	3	6	No. 5 at 8	9.29
c	3	7	No. 6 at 9	14.06
d	3	8	No. 8 at 12	21.01
e	4	$5\frac{1}{2}$	No. 5 at 10	6.93
f	4	6	No. 7 at 12	11.80
g	4	$7\frac{1}{2}$	No. 6 at 6	22.68
h	4	8	No. 8 at 12	21.23
i	5	5	No. 5 at 10	6.19
j	5	6	No. 5 at 8	9.66

**9.2** For each slab problem, determine the required steel reinforcement,  $A_s$ , and the total depth, if required; then choose adequate bars and their spacings. Use  $f_y = 60$  ksi for all problems,  $b = 12$  in., and a steel ratio close to the steel ratio  $\rho = A_s/bd$  given in some problems.

Number	$f'_c$ (ksi)	Mu (K · ft)	$h$ (in.)	$\rho$ (%)	One Answer	
					$h$ (in.)	Bars
a	3	5.4	6	—	6	No. 4 at 9 in.
b	3	13.8	$7\frac{1}{2}$	—	$7\frac{1}{2}$	No. 6 at 10 in.
c	3	24.4	—	0.85	9	No. 8 at 12 in.
d	3	8.1	5	—	5	No. 5 at 7 in.
e	4	22.6	—	1.18	$7\frac{1}{2}$	No. 7 at 8 in.
f	4	13.9	$8\frac{1}{2}$	—	$8\frac{1}{2}$	No. 6 at 12 in.
g	4	13.0	—	1.10	6	No. 6 at 8 in.
h	4	11.2	—	0.51	$7\frac{1}{2}$	No. 5 at 9 in.
i	5	20.0	9	—	9	No. 7 at 12 in.
j	5	10.6	—	0.90	6	No. 6 at 10 in.

**9.3** A 16-ft- (4.8-m)-span simply supported slab carries a uniform dead load of 200 psf (10 kN/m<sup>2</sup>) (excluding its own weight). The slab has a uniform thickness of 7 in. (175 mm) and is reinforced with no. 6 (20-mm) bars spaced at 5 in. (125 mm). Determine the allowable uniformly distributed load that can be applied on the slab if  $f'_c = 4$  ksi (28 MPa) and  $f_y = 60$  ksi (420 MPa).

**9.4** Design a 10-ft (3-m) cantilever slab to carry a uniform total dead load of 170 psf (8.2 kN/m<sup>2</sup>) and a concentrated live load at the free end of 2 K (8.9 kN), when  $f'_c = 4$  ksi (28 MPa) and  $f_y = 60$  ksi (420 MPa).

**9.5** A 6-in. (150-mm) solid one-way slab carries a uniform dead load of 190 psf (9.2 kN/m<sup>2</sup>) (including its own weight) and a live load of 80 psf (3.9 kN/m<sup>2</sup>). The slab spans 12 ft (3.6 m) between 10-in.- (250-mm)-wide simple supports. Determine the necessary slab reinforcement using  $f'_c = 4$  ksi (28 MPa) and  $f_y = 50$  ksi (350 MPa).



- 9.6** Repeat Problem 9.4 using a variable section with a minimum total depth at the free end of 4 in. (100 mm).
- 9.7** Design a continuous one-way solid slab supported on beams spaced at 14 ft (4.2 m) on centers. The width of the beams is 12 in. (300 mm), leaving clear slab spans of 13 ft (3.9 m). The slab carries a uniform dead load of 126 psf (6.0 kN/m<sup>2</sup>) (including self-weight of slab) and a live load of 120 psf (5.8 kN/m<sup>2</sup>). Use  $f'_c = 3$  ksi (21 MPa),  $f_y = 40$  ksi (280 MPa), and the ACI coefficients. Show bar arrangements using straight bars for all top and bottom reinforcement.
- 9.8** Repeat Problem 9.7 using equal clear spans of 13 ft (3 m),  $f'_c = 3$  ksi (21 MPa), and  $f_y = 60$  ksi (420 MPa).
- 9.9** Repeat Problem 9.7 using  $f'_c = 4$  ksi (28 MPa) and  $f_y = 60$  ksi (420 MPa).
- 9.10** Design an interior rib of a concrete joist floor system with the following description: Span of ribbed slab is 18 ft (5.4 m) between simple supports; uniform dead load (excluding self-weight) is 30 psf (1.44 kN/m<sup>2</sup>); live load is 100 psf (4.8 kN/m<sup>2</sup>); support width is 14 in. (350 mm);  $f'_c = 3$  ksi (21 MPa) and  $f_y = 60$  ksi (420 MPa). Use 30-in.-(750-mm)-wide removable pans.
- 9.11** Repeat Problem 9.10 using 20-in.-(500-mm)-wide removable pans.
- 9.12** Use the information given in Problem 9.10 to design a continuous ribbed slab with three equal spans of 18 ft (5.4 m) each.

# CHAPTER 10

## AXIALLY LOADED COLUMNS



Continuous slabs in a parking structure, New Orleans, Louisiana.

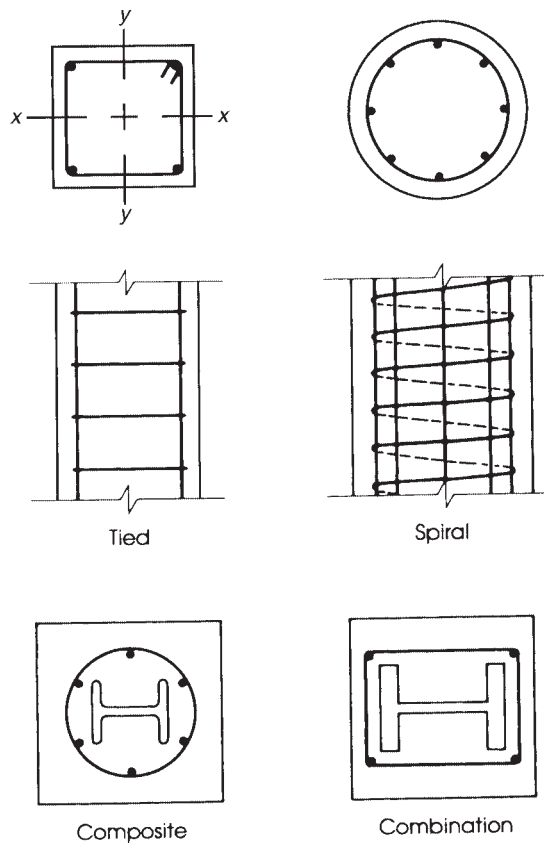
### 10.1 INTRODUCTION

Columns are members used primarily to support axial compressive loads and have a ratio of height to the least lateral dimension of 3 or greater. In reinforced concrete buildings, concrete beams, floors, and columns are cast monolithically, causing some moments in the columns due to end restraint. Moreover, perfect vertical alignment of columns in a multistory building is not possible, causing loads to be eccentric relative to the center of columns. The eccentric loads will cause moments in columns. Therefore, a column subjected to pure axial loads does not exist in concrete buildings. However, it can be assumed that axially loaded columns are those with relatively small eccentricity,  $e$ , of about  $0.1 h$  or less, where  $h$  is the total depth of the column and  $e$  is the eccentric distance from the center of the column. Because concrete has a high compressive strength and is an inexpensive material, it can be used in the design of compression members economically. This chapter deals only with short columns; slender columns are covered in detail in Chapter 12.

### 10.2 TYPES OF COLUMNS

Columns may be classified based on the following different categories (Fig. 10.1):

1. Based on loading, columns may be classified as follows:
  - a. Axially loaded columns, where loads are assumed acting at the center of the column section.



**Figure 10.1** Types of columns.

- b. Eccentrically loaded columns, where loads are acting at a distance  $e$  from the center of the column section. The distance  $e$  could be along the  $x$  or  $y$  axis, causing moments either about the  $x$  or  $y$  axis.
  - c. Biaxially loaded columns, where the load is applied at any point on the column section, causing moments about both the  $x$  and  $y$  axes simultaneously.
2. Based on length, columns may be classified as follows:
  - a. Short columns, where the column's failure is due to the crushing of concrete or the yielding of the steel bars under the full load capacity of the column.
  - b. Long columns, where buckling effect and slenderness ratio must be taken into consideration in the design, thus reducing the load capacity of the column relative to that of a short column.
3. Based on the shape of the cross section, column sections may be square, rectangular, round, L-shaped, octagonal, or any desired shape with an adequate side width or dimensions.
4. Based on column ties, columns may be classified as follows:
  - a. Tied columns containing steel ties to confine the main longitudinal bars in the columns. Ties are normally spaced uniformly along the height of the column.

- b. Spiral columns containing spirals (spring-type reinforcement) to hold the main longitudinal reinforcement and to help increase the column ductility before failure. In general, ties and spirals prevent the slender, highly stressed longitudinal bars from buckling and bursting the concrete cover.
5. Based on frame bracing, columns may be part of a frame that is braced against sidesway or unbraced against sidesway. Bracing may be achieved by using shear walls or bracings in the building frame. In braced frames, columns resist mainly gravity loads, and shear walls resist lateral loads and wind loads. In unbraced frames, columns resist both gravity and lateral loads, which reduces the load capacity of the columns.
6. Based on materials, columns may be reinforced, prestressed, composite (containing rolled steel sections such as I-sections), or a combination of rolled steel sections and reinforcing bars. Concrete columns reinforced with longitudinal reinforcing bars are the most common type used in concrete buildings.

### 10.3 BEHAVIOR OF AXIALLY LOADED COLUMNS

When an axial load is applied to a reinforced concrete short column, the concrete can be considered to behave elastically up to a low stress of about  $\left(\frac{1}{3}\right)f'_c$ . If the load on the column is increased to reach its design strength, the concrete will reach the maximum strength and the steel will reach its yield strength,  $f_y$ . The nominal load capacity of the column can be written as follows:

$$P_0 = 0.85f'_cA_n + A_{st}f_y \quad (10.1)$$

where  $A_n$  and  $A_{st}$  are the net concrete and total steel compressive areas, respectively.

$$A_n = A_g - A_{st}$$

where  $A_g$  is the gross concrete area.

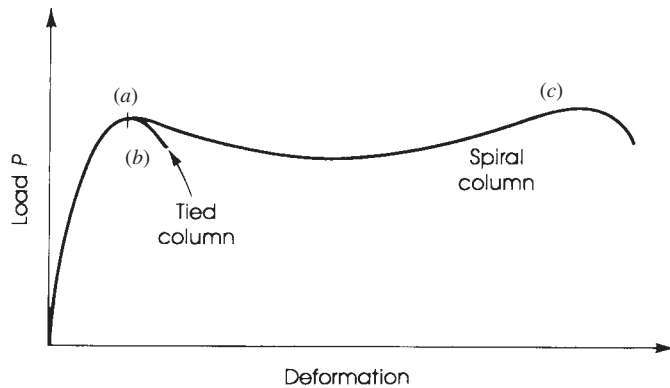
Two different types of failure occur in columns, depending on whether ties or spirals are used. For a tied column, the concrete fails by crushing and shearing outward, the longitudinal steel bars fail by buckling outward between ties, and the column failure occurs suddenly, much like the failure of a concrete cylinder.

A spiral column undergoes a marked yielding, followed by considerable deformation before complete failure. The concrete in the outer shell fails and spalls off. The concrete inside the spiral is confined and provides little strength before the initiation of column failure. A hoop tension develops in the spiral, and for a closely spaced spiral the steel may yield. A sudden failure is not expected. Figure 10.2 shows typical load deformation curves for tied and spiral columns. Up to point *a*, both columns behave similarly. At point *a*, the longitudinal steel bars of the column yield, and the spiral column shell spalls off. After the factored load is reached, a tied column fails suddenly (curve *b*), whereas a spiral column deforms appreciably before failure (curve *c*).

### 10.4 ACI CODE LIMITATIONS

The ACI Code presents the following limitations for the design of compression members:

1. For axially as well as eccentrically loaded columns, the ACI Code sets the strength reduction factors at  $\phi = 0.65$  for tied columns and  $\phi = 0.75$  for spirally reinforced columns. The difference of 0.10 between the two values shows the additional ductility of spirally reinforced columns.



**Figure 10.2** Behavior of tied and spiral columns.

The strength reduction factor for columns is much lower than those for flexure ( $\phi = 0.9$ ) and shear ( $\phi = 0.75$ ). This is because in axially loaded columns, the strength depends mainly on the concrete compression strength, whereas the strength of members in bending is less affected by the variation of concrete strength, especially in the case of an underreinforced section. Furthermore, the concrete in columns is subjected to more segregation than in the case of beams. Columns are cast vertically in long, narrow forms, but the concrete in beams is cast in shallow, horizontal forms. Also, the failure of a column in a structure is more critical than that of a floor beam.

2. The minimum longitudinal steel percentage is 1%, and the maximum percentage is 8% of the gross area of the section (ACI Code, Section 10.6.1.1). Minimum reinforcement is necessary to provide resistance to bending, which may exist, and to reduce the effects of creep and shrinkage of the concrete under sustained compressive stresses. Practically, it is very difficult to fit more than 8% of steel reinforcement into a column and maintain sufficient space for concrete to flow between bars.
3. At least four bars are required for tied circular and rectangular members and six bars are needed for circular members enclosed by spirals (ACI Code, Section 10.7.3.1). For other shapes, one bar should be provided at each corner, and proper lateral reinforcement must be provided. For tied triangular columns, at least three bars are required. Bars shall not be located at a distance greater than 6 in. clear on either side from a laterally supported bar. Figure 10.3 shows the arrangement of longitudinal bars in tied columns and the distribution of ties. Ties shown in dotted lines are required when the clear distance on either side from laterally supported bars exceeds 6 in. The minimum concrete cover in columns is 1.5 in.
4. The minimum ratio of spiral reinforcement,  $\rho_s$ , according to the ACI Code, Section 25.7.3.3, is

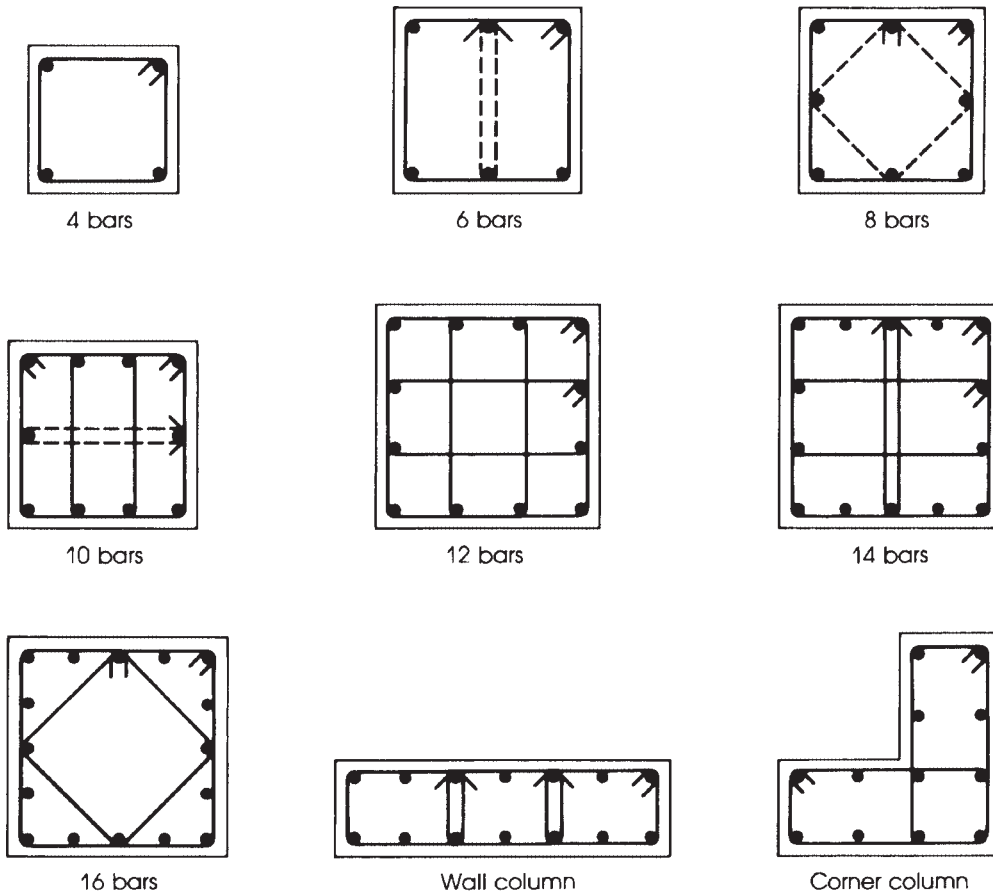
$$\rho_s \geq 0.45 \left( \frac{A_g}{A_{ch}} - 1 \right) \frac{f'_c}{f_{yt}} \quad (10.2)$$

where

$A_g$  = gross area of section

$A_{ch}$  = area of core of spirally reinforced column measured to the outside diameter of spiral

$f_{yt}$  = yield strength of spiral reinforcement ( $\leq 100$  ksi)



**Figure 10.3** Arrangement of bars and ties in columns.

5. The minimum diameter of spiral bar is  $\frac{3}{8}$  in. (ACI Code, Section 25.7.3.2), and their clear spacing according to ACI Code, Section 25.7.3.1 should not be more than 3 in. nor less than 1 in. or  $4/3$  the nominal maximum size of coarse aggregate. Splices may be provided by welding or by lapping the deformed uncoated spiral bars by 48 diameters or a minimum of 12 in. (ACI Code, Section 25.7.3.6). Lap splices for plain uncoated bar or wire =  $72d_p \leq 12$  in. The same applies for epoxy-coated deformed bar or wire. The Code also allows full mechanical splices. ACI Code, Table 25.7.3.56 gives details for the different cases.
6. Ties for columns must have a minimum diameter of  $\frac{3}{8}$  in. to enclose longitudinal bars of no. 10 size or smaller and a minimum diameter of  $\frac{1}{2}$  in. for larger bar diameters (ACI Code, Section 25.7.2).
7. Center to center spacing of ties shall not exceed the smallest of 48 times the tie bar diameter, 16 times the longitudinal bar diameter, or the least dimension of the member. Clear spacing of ties should be at least  $4/3$  the nominal maximum size of the aggregate. Table 10.1 gives the spacing for no. 3 and no. 4 ties. The Code does not give restrictions on the size of columns to allow wider utilization of reinforced concrete columns in smaller sizes.

**Table 10.1** Maximum Spacing of Ties

Column Least Side or Diameter (in.)	Spacing of Ties (in.) for Bar					
	No. 6	No. 7	No. 8	No. 9	No. 10	No. 11
12	12	12	12	12	12	12
14	12	14	14	14	14	14
16	12	14	16	16	16	16
18	12	14	16	18	18	18
20	12	14	16	18	18	20
22–40	12	14	16	18	18	22
Ties	No. 3	No. 3	No. 3	No. 3	No. 3	No. 4

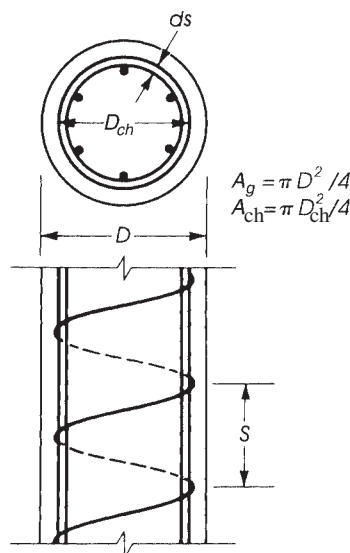
## 10.5 SPIRAL REINFORCEMENT

Spiral reinforcement in compression members prevents a sudden crushing of concrete and buckling of longitudinal steel bars. It has the advantage of producing a tough column that undergoes gradual and ductile failure. The minimum spiral ratio required by the ACI Code is meant to provide an additional compressive capacity to compensate for the spalling of the column shell. The strength contribution of the shell is

$$P_u(\text{shell}) = 0.85f'_c(A_g - A_{ch}) \quad (10.3)$$

where  $A_g$  is the gross concrete area and  $A_{ch}$  is the core area (Fig. 10.4).

In spirally reinforced columns, spiral steel is at least twice as effective as longitudinal bars; therefore, the strength contribution of spiral equals  $2\rho_s A_{ch} f_{yt}$ , where  $\rho_s$  is the ratio of volume of spiral reinforcement to total volume of core.

**Figure 10.4** Dimensions of a column spiral.

If the strength of the column shell is equated to the spiral strength contribution, then

$$0.85f'_c(A_g - A_{ch}) = 2\rho_s A_{ch} f_{yt}$$

$$\rho_s = 0.425 \left( \frac{A_g}{A_{ch}} - 1 \right) \frac{f'_c}{f_{yt}} \quad (10.4)$$

The ACI Code adopted a minimum ratio of  $\rho_s$  according to the following equation:

$$\text{Minimum } \rho_s = 0.45 \left( \frac{A_g}{A_{ch}} - 1 \right) \frac{f'_c}{f_{yt}}$$

The design relationship of spirals may be obtained as follows (Fig. 10.4):

$$\rho_s = \frac{\text{volume of spiral in one loop}}{\text{volume of core for a spacing } S}$$

$$= \frac{a_s \pi (D_{ch} - d_s)}{\left( \frac{\pi}{4} D_{ch}^2 \right) S} = \frac{4a_s (D_{ch} - d_s)}{D_{ch}^2 S} \quad (10.5)$$

where

- $a_s$  = area of spiral reinforcement
- $D_{ch}$  = diameter of the core measured to the outside diameter of spiral
- $D$  = diameter of the column
- $d_s$  = diameter of the spiral
- $S$  = spacing of the spiral

Table 10.2 gives spiral spacings for no. 3 and no. 4 spirals with  $f_y = 60$  ksi.

## 10.6 DESIGN EQUATIONS

The nominal load strength of an axially loaded column was given in Eq. 10.1. Because a perfect axially loaded column does not exist, some eccentricity occurs on the column section, thus reducing its load capacity,  $P_0$ . To take that into consideration, the ACI Code specifies that the maximum nominal load,  $P_0$ , should be multiplied by a factor equal to 0.8 for tied columns and 0.85 for spirally

**Table 10.2** Spirals for Circular Columns ( $f_y = 60$  ksi)

Column Diameter (in.)	Spacing (in.), $f'_c = 4$ ksi, No. 3 Spirals	$f'_c = 5$ ksi		Spacing (in.), $f'_c = 6$ ksi, No. 4 Spirals
		Spiral No.	Spacing (in.)	
12	2.0	4	2.75	2.25
14	2.0	4	3.00	2.25
16	2.0	4	3.00	2.50
18	2.0	4	3.00	2.50
20	2.0	4	3.00	2.50
22	2.0	4	3.00	2.50
24	2.0	3	1.75	2.50
26–40	2.25	3	1.75	2.75



reinforced columns. Introducing the strength reduction factor, the axial load strength of columns according to the ACI Code, Sections 22.4.2.2 and 22.4.2.3, are as follows:

$$P_u = \phi P_n = \phi(0.80)[0.85f'_c(A_g - A_{st}) + A_{st}f_y] \quad (10.6)$$

for tied columns and

$$P_u = \phi P_n = \phi(0.85)[0.85f'_c(A_g - A_{st}) + A_{st}f_y] \quad (10.7)$$

for spiral columns, where

$A_g$  = gross concrete area

$A_{st}$  = total steel compressive area

$\phi$  = 0.65 for tied columns and 0.75 for spirally reinforced columns

Equations 10.6 and 10.7 may be written as follows:

$$P_u = \phi P_n = \phi K[0.85f'_c A_g + A_{st}(f_y - 0.85f'_c)] \quad (10.8)$$

where  $\phi = 0.65$  and  $K = 0.8$  for tied columns and  $\phi = 0.75$  and  $K = 0.85$  for spiral columns.

If the gross steel ratio is  $\rho_g = A_{st}/A_g$ , or  $A_{st} = \rho_g A_g$ , then Eq. 10.8 may be written as follows:

$$P_u = \phi P_n = \phi K A_g [0.85f'_c + \rho_g (f_y - 0.85f'_c)] \quad (10.9)$$

Equation 10.8 can be used to calculate the axial load strength of the column, whereas Eq. 10.9 is used when the external factored load is given and it is required to calculate the size of the column section,  $A_g$ , based on an assumed steel ratio,  $\rho_g$ , between a minimum of 1% and a maximum of 8%.

It is a common practice to use grade 60 reinforcing steel bars in columns with a concrete compressive strength of 4 ksi or greater to produce relatively small concrete column sections.

## 10.7 AXIAL TENSION

Concrete will not crack as long as stresses are below its tensile strength; in this case, both concrete and steel resist the tensile stresses, but when the tension force exceeds the tensile strength of concrete (about one-tenth of the compressive strength), cracks develop across the section, and the entire tension force is resisted by steel. The nominal load that the member can carry is that due to tension steel only:

$$T_n = A_{st}f_y \quad (10.10)$$

$$T_u = \phi A_{st}f_y \quad (10.11)$$

where  $\phi$  is 0.9 for axial tension.

Tie rods in arches and similar structures are subjected to axial tension. Under working loads, the concrete cracks and the steel bars carry the whole tension force. The concrete acts as a fire and corrosion protector. Special provisions must be taken for water structures, as in the case of water tanks. In such designs, the concrete is not allowed to crack under the tension caused by the fluid pressure.

## 10.8 LONG COLUMNS

The equations developed in this chapter for the strength of axially loaded members are for short columns. In the case of long columns, the load capacity of the column is reduced by a reduction factor.

A long column is one with a high slenderness ratio,  $h/r$ , where  $h$  is the effective height of the column and  $r$  is the radius of gyration. The design of long columns is explained in detail in Chapter 12.

**Example 10.1**

Determine the allowable design axial load on a 12-in. square, short tied column reinforced with four no. 9 bars. Ties are no. 3 spaced at 12 in. Use  $f'_c = 4$  ksi and  $f_y = 60$  ksi.

**Solution**

- Using Eq. 10.9,

$$P_u = \phi P_n = \phi K [0.85f'_c A_g + A_{st}(f_y - 0.85f'_c)]$$

For a tied column,  $\phi = 0.65$ ,  $K = 0.8$ , and  $A_{st} = 4.0 \text{ in.}^2$

$$P_u = \phi P_n = 0.65(0.8)[0.85(4)(12 \times 12) + 4(60 - 0.85 \times 4)] = 372 \text{ K}$$

- Check steel percentage:  $\rho_g = \frac{4}{144} = 0.02778 = 2.778\%$ . This is less than 8% and greater than 1%.
- Check tie spacings: Minimum tie diameter is no. 3. Spacing is the smallest of the 48-tie diameter, 16-bar diameter, or least column side.  $S_1 = 16 \left(\frac{9}{8}\right) = 18 \text{ in.}$ ,  $S_2 = 48 \left(\frac{3}{8}\right) = 18 \text{ in.}$ ,  $S_3 = 12.0 \text{ in.}$  Ties are adequate (Table 10.1). Note: Clear spacing of ties should be at least  $4/3$  the nominal maximum size of the aggregate.

**Example 10.2**

Design a square tied column to support an axial dead load of 400 K and a live load of 232 K using  $f'_c = 5$  ksi,  $f_y = 60$  ksi, and a steel ratio of about 5%. Design the necessary ties.

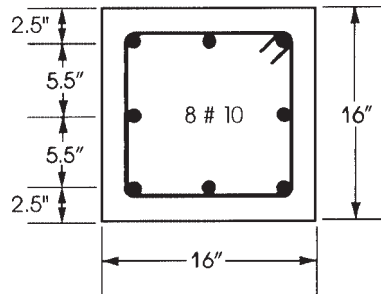
**Solution**

- Calculate  $P_u = 1.2P_D + 1.6P_L = 1.2(400) + 1.6(232) = 851 \text{ K}$ . Using Eq. 10.10,  $P_u = 851 = 0.65(0.8)A_g[0.85 \times 5 + 0.05(60 - 0.8 \times 5)]$ ,  $A_g = 232.5 \text{ in.}^2$ , and column side = 15.25 in., so use 16 in. (Actual  $A_g = 256 \text{ in.}^2$ .)
- Because a larger section is adopted, the steel percentage may be reduced by using  $A_g = 256 \text{ in.}^2$  in Eq. 10.8:

$$851 = 0.65(0.8)[0.85 \times 5 \times 256 + A_{st}(60 - 0.85 \times 5)]$$

$$A_{st} = 9.84 \text{ in.}^2$$

Use eight no. 10 bars ( $A_{st} = 10.16 \text{ in.}^2$ ). See Fig. 10.5.



**Figure 10.5** Example 10.2.

3. Design of ties (by calculation or from Table 10.1): Choose no. 3 ties with spacings equal to the least of  $S_1 = 16 \left(\frac{10}{8}\right) = 20$  in.,  $S_2 = 48 \left(\frac{3}{8}\right) = 18$  in., or  $S_3 =$  column side = 16 in. Use no. 3 ties spaced at 16 in. Clear distance between bars is 4.25 in., which is less than 6 in. Therefore, no additional ties are required.

### Example 10.3

Repeat Example 10.2 using a rectangular section that has a width of  $b = 14$  in.

#### Solution

- $P_u = 851$  K and calculated  $A_g = 232.5$  in.<sup>2</sup> For  $b = 14$  in.,  $h = 232.5/14 = 16.6$  in. Choose a column  $14 \times 18$  in.; actual  $A_g = 252$  in.<sup>2</sup>.
- $P_u = 851 = 0.65(0.8)[0.85 \times 5 \times 252 + A_{st}(60 - 0.85 \times 5)]$ .

$$A_{st} = 10.14 \text{ in.}^2$$

Use eight no. 10 bars ( $A_{st} = 10.16$  in.<sup>2</sup>).

- Design of ties: Choose no. 3 ties,  $S_1 = 20$  in.,  $S_2 = 18$  in., and  $S_3 = 14$  in. (least side). Use no. 3 ties spaced at 14 in. Clear distance between bars in the long direction is  $(18 - 5)/2$ -bar diameter of  $1.27 = 5.23$  in.  $< 6$  in. No additional ties are needed. Clear distance in the short direction is  $(14 - 5)/2 - 1.27 = 3.23$  in.  $< 6$  in.

### Example 10.4

Design a circular spiral column to support an axial dead load of 475 K and a live load of 250 K using  $f'_c = 4$  ksi,  $f_y = 60$  ksi, and a steel ratio of about 3%. Also, design the necessary spirals.

#### Solution

- Calculate  $P_u = 1.2 P_D + 1.6 P_L = 1.2(475) + 1.6(250) = 970$  K. Using Eq. 10.10 and spiral columns,

$$P_u = 970 = 0.75(0.85)A_g[0.85 \times 4 + 0.03(60 - 0.85 \times 4)]$$

$A_g = 299$  in.<sup>2</sup> and column diameter = 19.5 in., so use 20 in. Actual  $A_g = 314.2$  in.<sup>2</sup>.

- Calculate  $A_{st}$  needed from Eq. 10.8:

$$P_u = 970 = 0.75(0.85)[0.85 \times 4 \times 314.2 + A_{st}(60 - 0.85 \times 4)]$$

$$A_{st} = 8 \text{ in.}^2$$

Use eight no. 10 bars ( $A_{st} = 10.16$  in.<sup>2</sup>).

- Design of spirals: The diameter of core is  $20 - 2(1.5) = 17$  in. The area of core is

$$A_{ch} = \frac{\pi}{4}(17)^2 \quad A_g = \frac{\pi}{4}(20)^2$$

$$\text{Minimum } \rho_s = 0.45 \left( \frac{A_g}{A_{ch}} - 1 \right) \frac{f'_c}{f_{yt}} = 0.45 \left( \frac{20^2}{17^2} - 1 \right) \left( \frac{4}{60} \right) = 0.01152$$

Assume no. 3 spiral,  $a_s = 0.11 \text{ in.}^2$ , and  $d_s = 0.375 \text{ in.}$

$$\rho_s = 0.01152 = \frac{4a_s(D_{\text{ch}} - d_b)}{SD_{\text{ch}}^2} = \frac{4(0.11)(17 - 0.375)}{S(17)^2}$$

Spacing  $s$  is equal to 2.2 in; use no. 3 spiral at  $s = 2 \text{ in.}$  (as shown in Table 10.2).

### Example 10.5

Design a rectangular tied short column to carry a factored axial load of 1765 kN. Use  $f'_c = 30 \text{ MPa}$ ,  $f_y = 400 \text{ MPa}$ , column width ( $b$ ) = 300 mm, and a steel ratio of about 2%.

#### Solution SI Units

- Using Eq. 10.9,

$$P_u = 0.8\phi A_g [0.85f'_c + \rho_g(f_y - 0.85f'_c)]$$

Assuming a steel percentage of 2%,

$$1765 \times 10^3 = 0.8 \times 0.65 A_g [0.85 \times 30 + 0.02(400 - 0.85 \times 30)]$$

$$A_g = 102,887 \text{ mm}^2$$

For  $b = 300 \text{ mm}$ , the other side of the rectangular column is 343 mm. Therefore, use a section of  $300 \times 350 \text{ mm}$  ( $A_g = 105,000 \text{ mm}^2$ ).

- $A_s = 0.02 \times 102,887 = 2057 \text{ mm}^2$ . Choose six bars, 22 mm in diameter ( $A_s = 2280 \text{ mm}^2$ ).
- Check the axial load strength of the section using Eq. 10.6:

$$\begin{aligned} \phi P_n &= 0.8\phi [0.85f'_c(A_g - A_{st}) + A_{st}f_y] \\ &= 0.8 \times 0.65 [0.85 \times 30(105,000 - 2280) + 2280 \times 400] \times 10^{-3} \\ &= 1836 \text{ kN} \end{aligned}$$

This meets the required  $P_u$  of 1765 kN.

- Choose ties 10 mm in diameter. Spacing is the least of (1)  $16 \times 22 = 352 \text{ mm}$ , (2)  $48 \times 10 = 480 \text{ mm}$ , or (3) 300 mm. Choose 10-mm ties spaced at 300 mm. Note: Clear spacing of ties should be at least  $4/3$  the nominal maximum size of the aggregate.

## SUMMARY

### Sections 10.1–10.4

Columns may be tied or spirally reinforced:

$$\phi = \begin{cases} 0.65 & \text{for tied columns} \\ 0.75 & \text{for spirally reinforced columns} \end{cases}$$

Also,  $\rho_g$  must be  $\leq 8\%$  and  $\geq 1\%$ .

**Section 10.5**

Minimum ratio of spirals is

$$\rho_s = \begin{cases} 0.45 \left( \frac{A_g}{A_{ch}} - 1 \right) \frac{f'_c}{f_{yt}} \\ \frac{4a_s(D_{ch} - d_s)}{D_{ch}^2 S} \end{cases} \quad (\text{Eq. 10.2})$$

The minimum diameter of spirals is  $\frac{3}{8}$  in., and the clear spacing should not be more than 3 in. or less than 1 in.

**Section 10.6**

For tied columns,

$$P_u = \phi P_n = 0.8\phi[0.85f'_c(A_g - A_{st}) + A_{st}f_y] \quad (\text{Eq. 10.6})$$

or

$$P_u = \phi P_n = 0.8\phi A_g[0.85f'_c + \rho_g(f_y - 0.85f'_c)]$$

For spiral columns,

$$P_u = \phi P_n = 0.85\phi[0.85f'_c(A_g - A_{st}) + A_{st}f_y] \quad (\text{Eq. 10.7})$$

or

$$P_u = \phi P_n = 0.85\phi A_g[0.85f'_c + \rho_g(f_y - 0.85f'_c)]$$

where  $\rho_g = A_{st}/A_g$ .

**Section 10.7**

1. For axial tension,

$$T_u = \phi A_{st}f_y(\phi = 0.9) \quad (\text{Eq. 10.11})$$

2. Arrangements of vertical bars and ties in columns are shown in Fig. 10.3.

**REFERENCES**

1. ACI Committee 315. *Manual of Standard Practice for Detailing Reinforced Concrete Structures*. American Concrete Institute, Detroit, MI, 1999.
2. Concrete Reinforcing Steel Institute (CRSI). *CRSI Handbook*, 10th ed. CRSI, Chicago, IL, 2010.
3. B. Bresler and P. H. Gilbert. "Tie Requirements for Reinforced Concrete Columns." *ACI Journal* 58 (November 1961), pp. 555–570.
4. J. F. Pfister. "Influence of Ties on the Behavior of Reinforced Concrete Columns." *ACI Journal* 61 (May 1964), pp. 521–537.
5. N. G. Bunni. *Rectangular Ties in Reinforced Concrete Columns*. Publication No. SP-50. American Concrete Institute, Detroit, MI, 1975.

6. T. Huang. "On the Formula for Spiral Reinforcement." *ACI Journal* 61 (March 1964), pp. 351–354.
7. American Concrete Institute (ACI). *The Reinforced Concrete Design Manual, Vol. 1*, ACI Publication SP-17(11). ACI, Detroit, MI, 2011.

### PROBLEMS

- 10.1 Determine the factored axial load for each ( $\phi P_0$ ) for each of the following short rectangular columns according to the ACI Code limitations. Assume  $f_y = 60$  ksi and properly tied columns ( $b =$  width of column, in., and  $h =$  total depth, in.).

Number	$f'_c$ (ksi)	$b$ (in.)	$h$ (in.)	Bars	Answer ( $\phi P_n$ ) K
a	4	16	16	8 no. 9	688
b	4	20	20	16 no. 11	1442
c	4	12	12	8 no. 8	439
d	4	12	24	12 no. 10	955
e	5	14	14	10 no. 9	722
f	5	16	16	4 no. 10	712
g	5	14	26	12 no. 10	1244
h	5	18	32	8 no. 11	1634
i	6	16	16	8 no. 10	968
j	6	12	20	6 no. 10	852

- 10.2 Determine the factored axial load for each of the following short, spirally reinforced circular columns according to the ACI Code limitations. Assume  $f_y = 60$  ksi and the spirals are adequate ( $D =$  diameter of column, in.).

Number	$f'_c$ (ksi)	$D$ (in.)	Bars	Answer ( $\phi P_n$ ) K
a	4	14	8 no. 9	581
b	4	16	6 no. 10	663
c	5	18	8 no. 10	980
d	5	20	12 no. 10	1300
e	6	15	8 no. 9	797

- 10.3 For each problem, design a short square, rectangular, or circular column, as indicated, for each set of axial loads given, according to ACI limitations. Also, design the necessary ties or spirals and draw sketches of the column sections showing all bar arrangements. Use  $f_y = 60$  ksi and a steel ratio close to the  $\rho_g$  given ( $P_D =$  dead load,  $P_L =$  live load,  $b =$  width of a rectangular column, and  $\rho_g = A_{st}/A_g$ ).

Number	$f'_c$ (ksi)	$P_D$ (K)	$P_L$ (K)	$\rho_g$ %	Section	One Solution
a	4	200	200	4	Square	14 × 14, 8 no. 9
b	4	750	400	3.5	Square	24 × 24, 16 no. 10
c	4	220	165	7	Square	12 × 12, 8 no. 10
d	5	330	230	3	Square	16 × 16, 8 no. 9
e	4	190	170	2	Rectangular, $b = 12$ in.	12 × 18, 6 no. 8
f	4	280	315	4.5	Rectangular, $b = 14$ in.	14 × 20, 10 no. 10
g	4	210	150	3	Rectangular, $b = 12$ in.	12 × 16, 6 no. 9
h	5	690	460	2	Rectangular, $b = 18$ in.	18 × 32, 8 no. 10
i	4	350	130	4	Circular—spiral	16, 7 no. 9
j	4	475	220	3.25	Circular—spiral	20, 7 no. 10
k	4	400	260	5	Circular—spiral	18, 9 no. 10
l	5	285	200	4.25	Circular—spiral	15, 6 no. 10

For SI units, use 1 psi = 0.0069 MPa, 1 K = 4.45 kN, and 1 in. = 25.4 mm.

# CHAPTER 11

## MEMBERS IN COMPRESSION AND BENDING

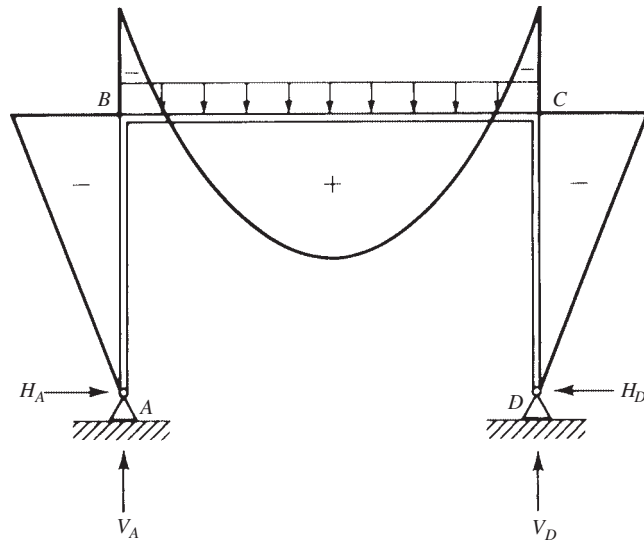


Residential building, Minneapolis, Minnesota.

### 11.1 INTRODUCTION

Vertical members that are part of a building frame are subjected to combined axial loads and bending moments. These forces develop due to external loads, such as dead, live, and wind loads. The forces are determined by manual calculations or computer applications that are based on the principles of statics and structural analysis. For example, Fig. 11.1 shows a two-hinged portal frame that carries a uniform factored load on  $BC$ . The bending moment is drawn on the tension side of the frame for clarification. Columns  $AB$  and  $CD$  are subjected to an axial compressive force and a bending moment. The ratio of the moment to the axial force is usually defined as the eccentricity  $e$ , where  $e = M_n/P_n$  (Fig. 11.1). The eccentricity  $e$  represents the distance from the plastic centroid of the section to the point of application of the load. The plastic centroid is obtained by determining the location of the resultant force produced by the steel and the concrete, assuming that both are stressed in compression to  $f_y$  and  $0.85 f'_c$ , respectively. For symmetrical sections, the plastic centroid coincides with the centroid of the section. For nonsymmetrical sections, the plastic centroid is determined by taking moments about an arbitrary axis, as explained in Example 11.1.

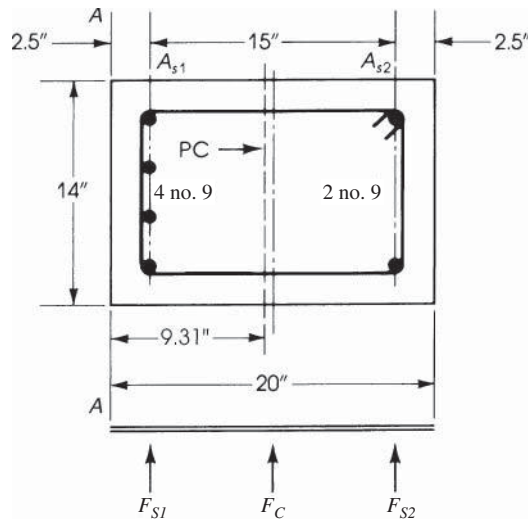




**Figure 11.1** Two-hinged portal frame with bending moment diagram drawn on the tension side.

### Example 11.1

Determine the plastic centroid of the section shown in Fig. 11.2. Given:  $f'_c = 4$  ksi and  $f_y = 60$  ksi.



**Figure 11.2** Example 11.1: Plastic centroid (PC) of section.

### Solution

1. It is assumed that the concrete is stressed in compression to  $0.85 f'_c$ :

$$\begin{aligned} F_c &= \text{force in concrete} = (0.85 f'_c) A_g \\ &= (0.85 \times 4) \times 14 \times 20 = 952 \text{ K} \end{aligned}$$

Force  $F_c$  is located at the centroid of the concrete section (at 10 in. from axis A-A).

2. Forces in steel bars:

$$F_{s1} = A_{s1}f_y = 4 \times 60 = 240 \text{ K}$$

$$F_{s2} = A_{s2}f_y = 2 \times 60 = 120 \text{ K}$$

3. Take moments about A–A:

$$x = \frac{(952 \times 10) + (240 \times 2.5) + (120 \times 17.5)}{952 + 240 + 120} = 9.31 \text{ in.}$$

Therefore, the plastic centroid lies at 9.31 in. from axis A–A.

4. If  $A_{s1} = A_{s2}$  (symmetrical section), then  $x = 10$  in. from axis A–A.

## 11.2 DESIGN ASSUMPTIONS FOR COLUMNS

The design limitations for columns, according to the ACI Code, Section 22.2.2, are as follows:

1. Strains in concrete and steel are proportional to the distance from the neutral axis.
2. Equilibrium of forces and strain compatibility must be satisfied.
3. The maximum usable compressive strain in concrete is 0.003.
4. Strength of concrete in tension can be neglected.
5. The stress in the steel is  $f_s = \epsilon E_s \leq f_y$ .
6. The concrete stress block may be taken as a rectangular shape with concrete stress of  $0.85 f'_c$  that extends from the extreme compressive fibers a distance  $a = \beta_1 c$ , where  $c$  is the distance to the neutral axis and  $\beta_1$  is 0.85 when  $f'_c \leq 4000$  psi (30 MPa);  $\beta_1$  decreases by 0.05 for each 1000 psi above 4000 psi (0.008 per 1 MPa above 30 MPa) but is not less than 0.65. (Refer to Fig. 3.6, Chapter 3.)

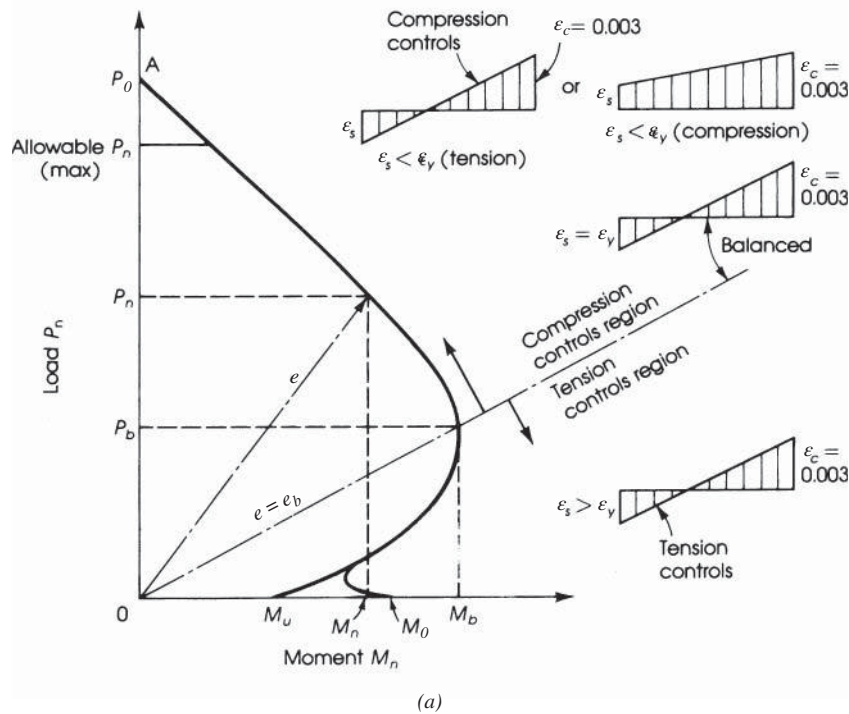
## 11.3 LOAD–MOMENT INTERACTION DIAGRAM

When a normal force is applied on a short reinforced concrete column, the following cases may arise, according to the location of the normal force with respect to the plastic centroid. Refer to Figs 1-3a and 11.3b:

1. *Axial Compression* ( $P_0$ ). This is a theoretical case assuming that a large axial load is acting at the plastic centroid;  $e = 0$  and  $M_n = 0$ . Failure of the column occurs by crushing of the concrete and yielding of steel bars. This is represented by  $P_0$  on the curve of Fig. 11.3a.
2. *Maximum Nominal Axial Load*  $P_{n, \max}$ . This is the case of a normal force acting on the section with minimum eccentricity. According to the ACI Code,  $P_{n, \max} = 0.80P_0$  for tied columns and  $0.85P_0$  for spirally reinforced columns, as explained in Chapter 10. In this case, failure occurs by crushing of the concrete and the yielding of steel bars.
3. *Compression Failure*. This is the case of a large axial load acting at a small eccentricity. The range of this case varies from a maximum value of  $P_n = P_{n, \max}$  to a minimum value of  $P_n = P_b$  (balanced load). Failure occurs by crushing of the concrete on the compression side with

a strain of 0.003, whereas the stress in the steel bars (on the tension side) is less than the yield strength,  $f_y$  ( $f_s < f_y$ ). In this case  $P_n > P_b$  and  $e < e_b$ .

4. **Balanced Condition ( $P_b$ ).** A balanced condition is reached when the compression strain in the concrete reaches 0.003 and the strain in the tensile reinforcement reaches  $\epsilon_y = f_y/E_s$  simultaneously; failure of concrete occurs at the same time as the steel yields. The moment that accompanies this load is called the *balanced moment*,  $M_b$ , and the relevant balanced eccentricity is  $e_b = M_b/P_b$ .
5. **Tension Failure.** This is the case of a small axial load with large eccentricity, that is, a large moment. Before failure, tension occurs in a large portion of the section, causing the tension steel bars to yield before actual crushing of the concrete. At failure, the strain in the tension steel is greater than the yield strain,  $\epsilon_y$ , whereas the strain in the concrete reaches 0.003. The range of this case extends from the balanced to the case of pure flexure (Fig. 11.3). When tension controls,  $P_n < P_b$  and  $e > e_b$ .
6. **Pure Flexure.** The section in this case is subjected to a bending moment,  $M_n$ , whereas the axial load is  $P_n = 0$ . Failure occurs as in a beam subjected to bending moment only. The eccentricity is assumed to be at infinity. Note that radial lines from the origin represent constant ratios of  $M_n/P_n = e =$  eccentricity of the load  $P_n$  from the plastic centroid.



**Figure 11.3** (a) Load–moment strength interaction diagram showing ranges of cases discussed in text and (b) column sections showing the location of  $P_n$  for different load conditions.

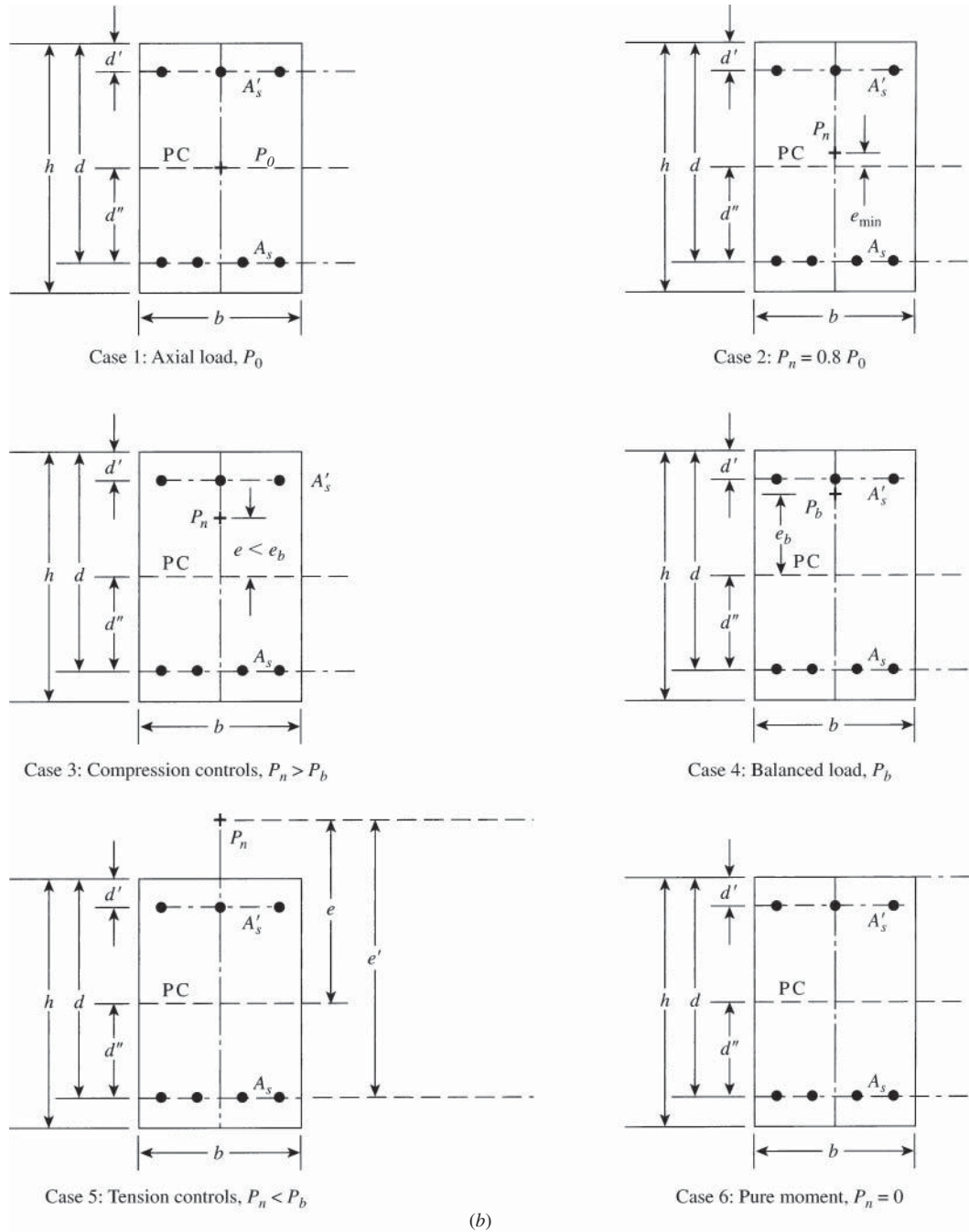


Figure 11.3 (Continued)

## 11.4 SAFETY PROVISIONS

The safety provisions for load factors were discussed earlier in Section 3.5. For columns, the safety provisions may be summarized as follows:

1. Load factors for gravity and wind loads are

$$U = 1.4D$$

$$U = 1.2D + 1.6L$$

$$U = 1.2D + (1.0L \text{ or } 0.5W)$$

$$U = 1.2D + 1.0L + 1.0W$$

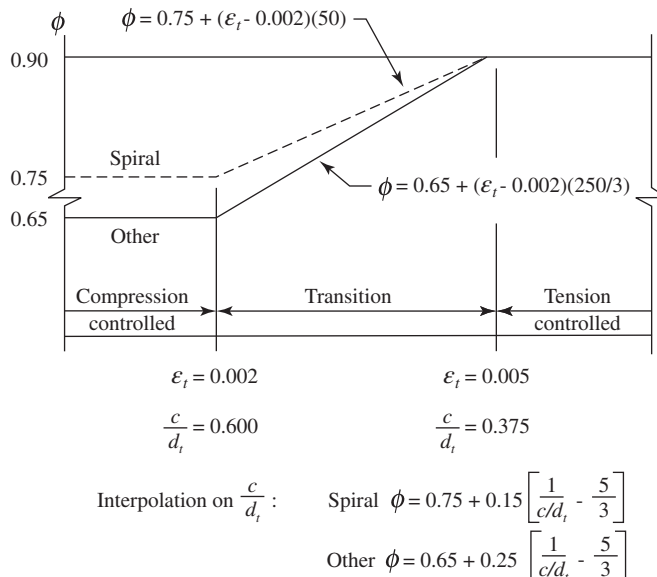
$$U = 0.9D + 1.0W$$

The most critical factored load should be used.

2. The strength reduction factor,  $\phi$ , to be used for columns may vary according to the following cases:

- a. When  $P_u = \phi P_n \geq 0.1f'_c A_g$ ,  $\phi$  is 0.65 for tied columns and 0.75 for spirally reinforced columns. This case occurs generally when compression failure is expected. Area  $A_g$  is the gross area of the concrete section.
- b. The sections in which the net tensile strain,  $\epsilon_t$ , at the extreme tension steel, at nominal strength, is between 0.005 and 0.002 (transition region)  $\phi$  varies linearly between 0.90 and 0.65 (or 0.75), respectively (Fig. 11.4). Refer to Section 3.7. For spiral sections,

$$\phi = 0.75 + (\epsilon_t - 0.002)(50) \quad \text{or} \quad \phi = 0.75 + 0.15 \left[ \frac{1}{c/d_t} - \frac{5}{3} \right] \quad (11.1)$$



**Figure 11.4** Variation in  $\phi$  with NTS for grade 60 steel 7. Courtesy of ACI.

For tied sections

$$\phi = 0.65 + (\epsilon_t - 0.002) \left( \frac{250}{3} \right) \quad \text{or} \quad \phi = 0.65 + 0.25 \left[ \frac{1}{c/d_t} - \frac{5}{3} \right] \quad (11.2)$$

- c. When  $P_u = 0$ , the case of pure flexure, then  $\phi = 0.90$  for tension-controlled sections and varies between 0.90 and 0.65 (or 0.75) in the transition region.

## 11.5 BALANCED CONDITION: RECTANGULAR SECTIONS

A balanced condition occurs in a column section when a load is applied on the section and produces, at nominal strength, a strain of 0.003 in the compressive fibers of concrete and a strain  $\epsilon_y = f_y/E_s$  in the tension steel bars simultaneously. This is a special case where the neutral axis can be determined from the strain diagram with known extreme values. When the applied eccentric load is greater than  $P_b$ , compression controls; if it is smaller than  $P_b$ , tension controls in the section.

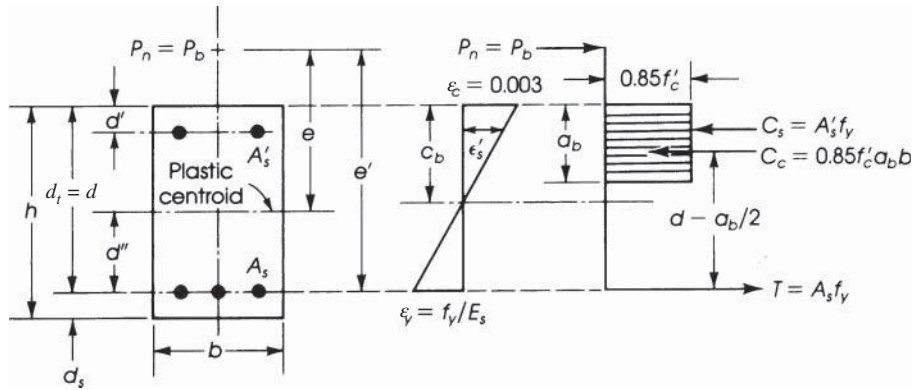


Columns supporting 52-story building, Minneapolis, Minnesota. (Columns are 96 × 64 in. with round ends.).

The analysis of a balanced column section can be explained in steps (Fig. 11.5):

1. Let  $c$  equal the distance from the extreme compressive fibers to the neutral axis. From the strain diagram,

$$\frac{c_b(\text{balanced})}{d_t} = \frac{0.003}{0.003 + f_y/E_s} \quad (\text{where } E_s = 29,000 \text{ ksi}) \quad (11.3)$$



**Figure 11.5** Balanced condition (rectangular section).

and

$$c_b = \frac{87d_t}{87 + f_y} \quad (\text{where } f_y \text{ is in ksi})$$

The depth of the equivalent compressive block is

$$a_b = \beta_1 c_b = \left( \frac{87}{87 + f_y} \right) \beta_1 d_t \quad (11.4)$$

where  $\beta_1 = 0.85$  for  $f'_c \leq 4000$  psi and decreases by 0.05 for each 1000-psi increase in  $f'_c$ .

2. From equilibrium, the sum of the horizontal forces equals 0:  $P_b - C_c - C_s + T = 0$ , where

$$\begin{aligned} C_c &= 0.85f'_c ab \quad \text{and} \quad T = A_s f_y \\ C_s &= A'_s (f'_s - 0.85f'_c) \end{aligned} \quad (11.5)$$

(Use  $f'_s = f_y$  if compression steel yields.)

$$f'_s = 87 \left( \frac{c - d'}{c} \right) \leq f_y$$

The expression of  $C_s$  takes the displaced concrete into account. Therefore, Eq. 11.5 becomes

$$P_b = 0.85f'_c ab + A'_s (f'_s - 0.85f'_c) - A_s f_y \quad (11.6)$$

3. The eccentricity  $e_b$  is measured from the plastic centroid and  $e'$  is measured from the centroid of the tension steel:  $e' = e + d''$  (in this case  $e' = e_b + d''$ ), where  $d''$  is the distance from the plastic centroid to the centroid of the tension steel. The value of  $e_b$  can be determined by taking moments about the plastic centroid:

$$P_b e_b = C_c \left( d - \frac{a}{2} - d'' \right) + C_s (d - d' - d'') + T d'' \quad (11.7)$$

or

$$P_b e_b = M_b = 0.85f'_c ab \left( d - \frac{a}{2} - d'' \right) + A'_s (f_y - 0.85f'_c) (d - d' - d'') + A_s f_y d'' \quad (11.8)$$

The balanced eccentricity is

$$e_b = \frac{M_b}{P_b} \quad (11.9)$$

For nonrectangular sections, the same procedure applies, taking into consideration the actual area of concrete in compression.

The strength reduction factor,  $\phi$ , for the balanced condition with  $f_y = 60$  ksi, can be assumed = 0.65 (or 0.75). This is because  $\epsilon_s = \epsilon_t = f_y/E_s = 0.00207$  (or 0.002), for which  $\phi = 0.65$  (Fig. 11.4).

### Example 11.2

Determine the balanced compressive force  $P_b$ ; then determine  $e_b$  and  $M_b$  for the section shown in Fig. 11.6. Given:  $f'_c = 4$  ksi and  $f_y = 60$  ksi.

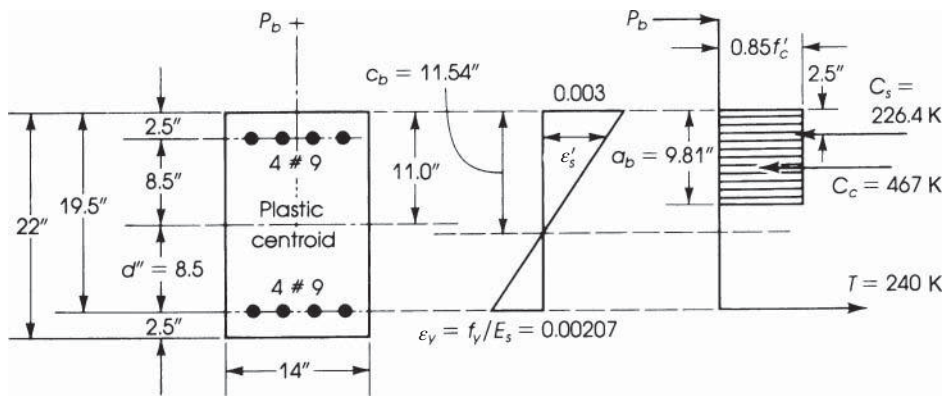


Figure 11.6 Example 11.2: Balanced condition.

### Solution

1. For a balanced condition, the strain in the concrete is 0.003 and the strain in the tension steel is

$$\epsilon_y = \frac{f_y}{E_s} = \frac{60}{29,000} = 0.00207$$

2. Locate the neutral axis:

$$c_b = \frac{87}{87 + f_y} d_t = \frac{87}{87 + 60} (19.5) = 11.54 \text{ in.}$$

$$a_b = 0.85c_b = 0.85 \times 11.54 = 9.81 \text{ in.}$$

3. Check if compression steel yields. From the strain diagram,

$$\frac{\epsilon'_s}{0.003} = \frac{c - d'}{c} = \frac{11.54 - 2.5}{11.54} \quad \epsilon'_s = 0.00235$$

which exceeds  $\epsilon_y$  of 0.00207; thus, compression steel yields. Or check that

$$\begin{aligned} f'_s &= 87 \left( \frac{c - d''}{c} \right) \leq f_y \\ &= \frac{87(11.54 - 2.5)}{11.54} = 68 \text{ ksi} > 60 \text{ ksi} \end{aligned}$$

Then  $f'_s = f_y = 60$  ksi.



4. Calculate the forces acting on the section:

$$C_c = 0.85f'_c ab = 0.85 \times 4 \times 9.81 \times 14 = 467 \text{ K}$$

$$T = A_s f_y = 4 \times 60 = 240 \text{ K}$$

$$C_s = A'_s (f_y - 0.85f'_c) = 4(60 - 3.4) = 226.4 \text{ K}$$

5. Calculate  $P_b$  and  $e_b$ :

$$P_b = C_c + C_s - T = 467 + 226.4 - 240 = 453.4 \text{ K}$$

From Eq. 11.7,

$$M_b = P_b e_b = C_c \left( d - \frac{a}{2} - d'' \right) + C_s (d - d' - d'') + T d''$$

The plastic centroid is at the centroid of the section, and  $d'' = 8.5$  in.

$$\begin{aligned} M_b &= 453.4 e_b = 467 \left( 19.5 - \frac{9.81}{2} - 8.5 \right) + 226.4(19.5 - 2.5 - 8.5) + 240 \times 8.5 \\ &= 6810.8 \text{ K} \cdot \text{in.} = 567.6 \text{ K} \cdot \text{ft} \end{aligned}$$

$$e_b = \frac{M_b}{P_b} = \frac{6810.8}{453.4} = 15.0 \text{ in.}$$

6. For a balanced condition,  $\phi = 0.65$ ,  $\phi P_b = 294.7 \text{ K}$ , and  $\phi M_b = 368.9 \text{ K} \cdot \text{ft}$ .

## 11.6 COLUMN SECTIONS UNDER ECCENTRIC LOADING

For the two cases when compression or tension failure occurs, two basic equations of equilibrium can be used in the analysis of columns under eccentric loadings: (1) the sum of the horizontal or vertical forces = 0, and (2) the sum of moments about any axis = 0. Referring to Fig. 11.7, the following equations may be established.

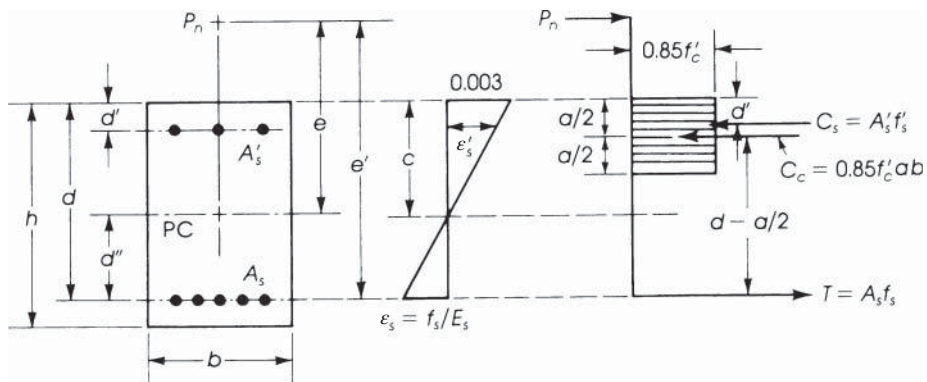


Figure 11.7 General case, rectangular section.



Reinforced concrete tied column under construction. The two columns are separated by an expansion joint.

1.

$$P_n - C_c - C_s + T = 0 \quad (11.10)$$

where

$$\begin{aligned} C_c &= 0.85f'_c ab \\ C_s &= A'_s(f'_s - 0.85f'_c) \quad (\text{If compression steel yields, then } f'_s = f_y.) \\ T &= A_s f_s \quad (\text{If tension steel yields, then } f_s = f_y.) \end{aligned}$$

2. Taking moments about  $A_s$ ,

$$P_n e' - C_c \left( d - \frac{a}{2} \right) - C_s (d - d') = 0 \quad (11.11)$$

The quantity  $e' = e + d''$ , and  $e' = (e + d - h/2)$  for symmetrical reinforcement ( $d''$  is the distance from the plastic centroid to the centroid of the tension steel.)

$$P_n = \frac{1}{e'} \left[ C_c \left( d - \frac{a}{2} \right) + C_s (d - d') \right] \quad (11.12)$$

Taking moments about  $C_c$ ,

$$P_n \left[ e' - \left( d - \frac{a}{2} \right) \right] - T \left( d - \frac{a}{2} \right) - C_s \left( \frac{a}{2} - d' \right) = 0 \quad (11.13)$$

and

$$P_n = \frac{T(d - a/2) + C_s(a/2 - d')}{(e' + a/2 - d)} \quad (11.14)$$

If  $A_s = A'_s$  and  $f_s = f'_s = f_y$ , then

$$P_n = \frac{A_s f_y (d - d')}{(e' + a/2 - d)} = \frac{A_s f_y (d - d')}{(e - h/2 + a/2)} \quad (11.15)$$

$$A_s = A'_s = \frac{P_n (e - h/2 + a/2)}{f_y (d - d')} \quad (11.16)$$

## 11.7 STRENGTH OF COLUMNS FOR TENSION FAILURE

When a column is subjected to an eccentric force with large eccentricity  $e$ , tension failure is expected. The column section fails due to the yielding of steel and crushing of concrete when the strain in the steel exceeds  $\epsilon_y$  ( $\epsilon_y = f_y/E_s$ ). In this case the nominal strength,  $P_n$ , will be less than  $P_b$  or the eccentricity,  $e = M_n/P_n$ , is greater than the balanced eccentricity,  $e_b$ . Because it is difficult in some cases to predict if tension or compression controls, it can be assumed (as a guide) a tension failure will occur when  $e > d$ . This assumption should be checked later.

The general equations of equilibrium, Eqs. 11.10 and Eqs. 11.11, may be used to calculate the nominal strength of the column. This is illustrated in steps as follows:

1. For tension failure, the tension steel yields and its stress is  $f_s = f_y$ . Assume that stress in compression steel is  $f'_s = f_y$ .
2. Evaluate  $P_n$  from equilibrium conditions (Eq. 11.10):

$$P_n = C_c + C_s - T$$

where  $C_c = 0.85f'_c ab$ ,  $C_s = A'_s(f_y - 0.85f'_c)$ , and  $T = A_s f_y$ .

3. Calculate  $P_n$  by taking moments about  $A_s$  (Eq. 11.11):

$$P_n e' = C_c \left( d - \frac{a}{2} \right) + C_s (d - d')$$

where  $e' = e + d''$  and  $e' = e + d - h/2$  when  $A_s = A'_s$ .

4. Equate  $P_n$  from steps 2 and 3:

$$C_c + C_s - T = \frac{1}{e'} \left[ C_c \left( d - \frac{a}{2} \right) + C_s (d - d') \right]$$

This is a second-degree equation in  $a$ . Substitute the values of  $C_c$ ,  $C_s$ , and  $T$  and solve for  $a$ .

5. The second-degree equation, after the substitution of  $C_c$ ,  $C_s$ , and  $T$ , is reduced to the following equation:

$$Aa^2 + Ba + C = 0$$

where

$$\begin{aligned} A &= 0.425f'_c b \\ B &= 0.85f'_c b(e' - d) = 2A(e' - d) \\ C &= A'_s(f'_s - 0.85f'_c)(e' - d + d') - A_s f_y e' \end{aligned}$$

Solve for  $a$  to get

$$a = \frac{-B \pm \sqrt{B^2 - 4AC}}{2A}$$

Note that the value of  $f'_s - 0.85f'_c$  must be a positive value. If this value is negative, then let  $f'_s - 0.85f'_c = 0$ .

6. Substitute  $a$  in the equation of step 2 to obtain  $P_n$ . The moment  $M_n$  can be calculated:

$$M_n = P_n e$$

7. Check if compression steel yields as assumed. If  $\epsilon'_s \geq \epsilon_y$ , then compression steel yields; otherwise,  $f'_s = E_s \epsilon'_s$ . Repeat steps 2 through 5. Note that  $\epsilon'_s = [(c - d')/c]0.003$ ,  $\epsilon_y = f_y/E_s$ , and  $a = \beta_1 c$ .
8. Check that tension controls. Tension controls when  $e > e_b$  or  $P_n < P_b$ . Example 11.3 illustrates this procedure.
9. The net tensile strain,  $\epsilon_t$ , in this section, is normally greater than the limit strain of 0.002 for a compression-controlled section (Fig. 11.4). Consequently, the value of the strength reduction factor,  $\phi$ , will vary between 0.65 (or 0.75) and 0.90. Equation 11.1 or 11.2 can be used to calculate  $\phi$ .

### Example 11.3

Determine the nominal compressive strength,  $P_n$ , for the section given in Example 11.2 if  $e = 20$  in. (See Fig. 11.8.)

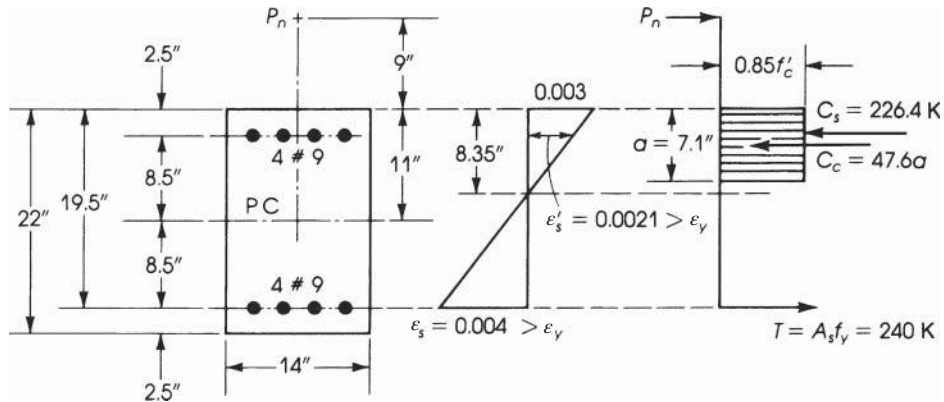


Figure 11.8 Example 11.3: Tension failure.

### Solution

- Because  $e = 20$  in. is greater than  $d = 19.5$  in., assume that tension failure condition controls (to be checked later). The strain in the tension steel,  $\epsilon_s$ , will be greater than  $\epsilon_y$  and its stress is  $f_y$ . Assume that compression steel yields  $f'_s = f_y$ , which should be checked later.
- From the equation of equilibrium (Eq. 11.10),

$$P_n = C_c + C_s - T$$

where

$$C_c = 0.85f'_c ab = 0.85 \times 4 \times 14a = 47.6a$$

$$C_s = A'_s(f_y - 0.85f'_c) = 4(60 - 0.85 \times 4) = 226.4 \text{ K}$$

$$T = A_s f_y = 4 \times 60 = 240 \text{ K}$$

$$P_n = 47.6a + 226.4 - 240 = 47.6a - 13.6$$

(I)

3. Taking moments about  $A_s$  (Eq. 11.12),

$$P_n = \frac{1}{e'} \left[ C_c \left( d - \frac{a}{2} \right) + C_s (d - d') \right]$$

Note that for the plastic centroid at the center of the section,  $d'' = 8.5$  in.

$$e' = e + d'' = 20 + 8.5 = 28.5 \text{ in.}$$

$$P_n = \frac{1}{28.5} \left[ 47.6a \left( 19.5 - \frac{a}{2} \right) + 226.4 \times 17 \right]$$

$$P_n = 32.56a - 0.835a^2 + 135.0$$

4. Equating Eqs. I and II,

$$P_n = 47.6a - 13.6 = 32.56a - 0.835a^2 + 135.0 \quad (\text{II})$$

or

$$a^2 + 18a - 178.0 = 0 \quad a = 7.1 \text{ in.}$$

5. From Eq. I:

$$P_n = 47.6 \times 7.1 - 13.6 = 324.4 \text{ K}$$

$$M_n = P_n e = 324.4 \times \frac{20}{12} = 540.67 \text{ K} \cdot \text{ft}$$

6. Check if compression steel has yielded:

$$c = \frac{a}{0.85} = \frac{7.1}{0.85} = 8.35 \text{ in.} \quad \epsilon_y = \frac{60}{29,000} = 0.00207$$

$$\epsilon'_s = \frac{8.35 - 2.5}{8.35} 0.003 = 0.0021 > \epsilon_y$$

Compression steel yields. Check strain in tension steel:

$$\epsilon_s = \left( \frac{19.5 - 8.35}{8.35} \right) \times 0.003 = 0.004 > \epsilon_y$$

If compression steel does not yield, use  $f'_s$  as calculated from  $f'_s = \epsilon'_s E_s$  and revise the calculations.

7. Calculate  $\phi$ : Since  $\epsilon_t = 0.004$ , the section is in the transition region.

$$\phi = 0.65 + (\epsilon_t - 0.002)(250/3) = 0.817$$

$$\phi P_n = 0.817(324.4) = 264.9 \text{ K}$$

$$\phi M_n = 0.817(540.67) = 441.7 \text{ K} \cdot \text{ft}$$

8. Because  $e = 20$  in.  $> e_b = 15$  in. (Example 11.2), there is a tension failure condition.

9. The same results can be obtained using the values of  $A$ ,  $B$ , and  $C$  given earlier.

$$Aa^2 + Ba + C = 0$$

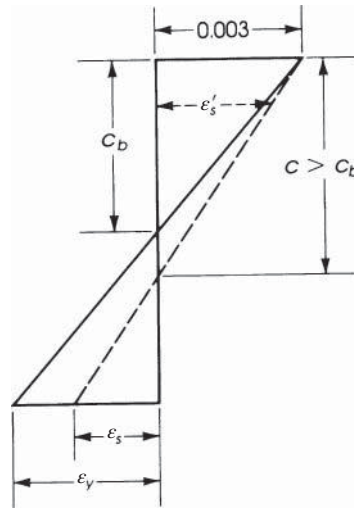
where

$$A = 0.425f'_c b = 0.425(4)(14) = 23.8$$

$$B = 2A(e' - d) = 2(23.8)(28.5 - 19.5) = 428.4$$

$$C = 4(60 - 0.85 \times 4)(28.5 - 19.5 + 2.5) - 4(60)(28.5) \\ = -4236.4$$

Solve for  $a$  to get  $a = 7.1$  in. and  $P_n = 324.4$  K.



**Figure 11.9** Strain diagram when compression controls. When  $\epsilon_s < \epsilon_y$ ,  $c > c_b$  and  $\epsilon'_s \geq \epsilon_y$ .

## 11.8 STRENGTH OF COLUMNS FOR COMPRESSION FAILURE

If the compressive applied force,  $P_n$ , exceeds the balanced force,  $P_b$ , or the eccentricity,  $e = M_n/P_n$ , is less than  $e_b$ , compression failure is expected. In this case compression controls, and the strain in the concrete will reach 0.003, whereas the strain in the steel is less than  $\epsilon_y$  (Fig. 11.9). A large part of the column will be in compression. The neutral axis moves toward the tension steel, increasing the compression area, and therefore the distance to the neutral axis  $c$  is greater than the balanced  $c_b$  (Fig. 11.9).

Because it is difficult to predict compression or tension failure whenever a section is given, compression failure can be assumed when  $e < 2d/3$ , which should be checked later. The nominal load strength,  $P_n$ , can be calculated using the principles of statics. The analysis of column sections for compression failure can be achieved using Eqs. 11.10 and Eqs. 11.11 given earlier and one of the following solutions.

### 11.8.1 Trial Solution

This solution can be summarized as follows:

1. Calculate the distance to the neutral axis for a balanced section,  $c_b$ :

$$c_b = \left( \frac{87d_t}{87 + f_y} \right) \quad (11.17)$$

where  $f_y$  is in ksi.

2. Evaluate  $P_n$  using equilibrium conditions:

$$P_n = C_c + C_s - T \quad (11.18)$$

3. Evaluate  $P_n$  by taking moments about the tension steel,  $A_s$ :

$$P_n \cdot e' = C_c \left( d - \frac{a}{2} \right) + C_s(d - d') \quad (11.19)$$

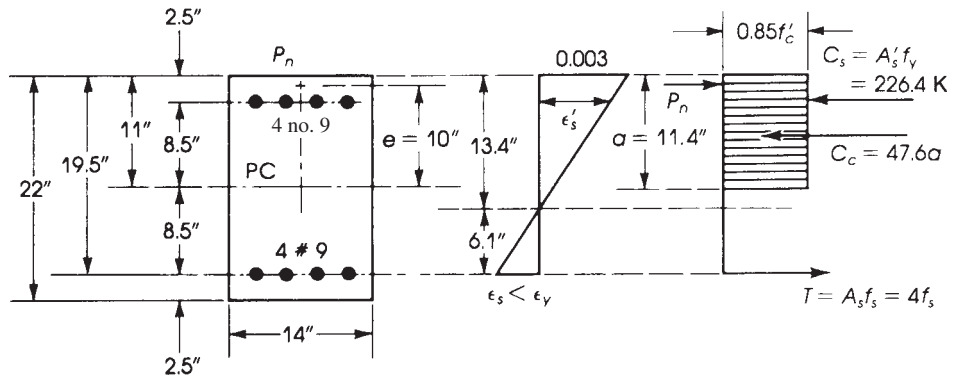


Figure 11.10 Example 11.4: Compression controls.

where  $e' = e + d - h/2$  when  $A_s = A'_s$  or  $e' = e + d''$  in general,  $C_c = 0.85f'_c ab$ ,  $C_s = A'_s(f'_s - 0.85f'_c)$ , and  $T = A_s f_s$ .

4. Assume a value for  $c$  such that  $c > c_b$  (calculated in step 1). Calculate  $a = \beta_1 c$ . Assume  $f'_s = f_y$ .
5. Calculate  $f_s$  based on the assumed  $c$ :

$$f_s = \epsilon_s E_s = 87 \left( \frac{d_t - c}{c} \right) \text{ ksi} \leq f_y$$

6. Substitute the preceding values in Eq. 11.10 to calculate  $P_{n1}$  and in Eq. 11.11 to calculate  $P_{n2}$ . If  $P_{n1}$  is close to  $P_{n2}$ , then choose the smaller or average of  $P_{n1}$  and  $P_{n2}$ . If  $P_{n1}$  is not close to  $P_{n2}$ , assume a new  $c$  or  $a$  and repeat the calculations starting from step 4 until  $P_{n1}$  is close to  $P_{n2}$ . (1% is quite reasonable.)
7. Check that compression steel yields by calculating  $\epsilon'_s = 0.003[(c - d')/c]$  and comparing it with  $\epsilon_y = f_y/E_s$ . When  $\epsilon'_s \geq \epsilon_y$ , compression steel yields; otherwise,  $f'_s = \epsilon'_s E_s$  or, directly,

$$f'_s = 87 \left( \frac{c - d'}{c} \right) \leq f_y \text{ ksi}$$

8. Check that  $e < e_b$  or  $P_n > P_b$  for compression failure. Example 11.4 illustrates the procedure.
9. The net tensile strain,  $\epsilon_t$ , in the section is normally less than 0.002 for compression-controlled sections (Fig. 11.4). Consequently, the strength reduction factor ( $\phi$ ) = 0.65 (or 0.70 for spiral columns).

#### Example 11.4

Determine the nominal compressive strength,  $P_n$ , for the section given in Example 11.2 if  $e = 10$  in. (See Fig. 11.10.)

#### Solution

1. Because  $e = 10$  in.  $< \left(\frac{2}{3}\right) d = 13$  in., assume compression failure. This assumption will be checked later. Calculate the distance to the neutral axis for a balanced section,  $c_b$ :

$$c_b = \frac{87}{87 + f_y} d_t = \frac{87}{87 + 60} (19.5) = 11.54 \text{ in.}$$

2. From the equations of equilibrium,

$$P_n = C_c + C_s - T \quad (\text{Eq. 11.10})$$

where

$$C_c = 0.85f'_c ab = 0.85 \times 4 \times 14a = 47.6a$$

$$C_s = A'_s(f_y - 0.85f'_c) = 4(60 - 0.85 \times 4) = 226.4 \text{ K}$$

Assume compression steel yields. (This assumption will be checked later.)

$$T = A_s f_s = 4f_s \quad f_s < f_y$$

$$P_n = 47.6a + 226.4 - 4f_s \quad (\text{I})$$

3. Taking moments about  $A_s$ ,

$$P_n = \frac{1}{e'} \left[ C_c \left( d - \frac{a}{2} \right) + C_s (d - d') \right] \quad (\text{Eq. 11.11})$$

The plastic centroid is at the center of the section and  $d'' = 8.5$  in.

$$e' = e + d'' = 10 + 8.5 = 18.5 \text{ in.}$$

$$\begin{aligned} P_n &= \frac{1}{18.5} \left[ 47.6a \left( 19.5 - \frac{a}{2} \right) + 226.4(19.5 - 2.5) \right] \\ &= 50.17a - 1.29a^2 + 208 \end{aligned} \quad (\text{II})$$

4. Assume  $c = 13.45$  in., which exceeds  $c_b$  (11.54 in.).

$$a = 0.85 \times 13.45 = 11.43 \text{ in.}$$

Substitute  $a = 11.43$  in Eq. II:

$$P_{n1} = 50.17 \times 11.43 - 1.29(11.43)^2 + 208 = 612.9 \text{ K}$$

5. Calculate  $f_s$  from the strain diagram when  $c = 13.45$  in.

$$f_s = \left( \frac{19.5 - 13.45}{13.45} \right) 87 = 39.13 \text{ ksi} \quad \epsilon_s = \epsilon_t = \frac{f_s}{E_s} = 0.00135$$

6. Substitute  $a = 11.43$  in. and  $f_s = 39.13$  ksi in Eq. I to calculate  $P_{n2}$ :

$$P_{n2} = 47.6(11.43) + 226.4 - 4(39.13) = 613.9 \text{ K}$$

which is very close to the calculated  $P_{n1}$  of 612.9 K (less than 1% difference).

$$M_n = P_n e = 612.9 \left( \frac{10}{12} \right) = 510.8 \text{ K} \cdot \text{ft}$$

7. Check if compression steel yields. From the strain diagram,

$$\epsilon'_s = \frac{13.45 - 2.5}{13.45} (0.003) = 0.00244 > \epsilon_y = 0.00207$$

Compression steel yields, as assumed.

8.  $P_n = 612.9 \text{ K}$  is greater than  $P_b = 453.4 \text{ K}$ , and  $e = 10$  in.  $< e_b = 15$  in., both calculated in the previous example, indicating that compression controls, as assumed. Note that it may take a few trials to get  $P_{n1}$  close to  $P_{n2}$ .



9. Calculate  $\phi$ :

$$d_t = d = 19.5 \text{ in.} \quad c = 13.45 \text{ in.}$$

$$\begin{aligned} \varepsilon_t \text{ (at tension steel level)} &= \frac{0.003(d_t - c)}{c} \\ &= \frac{0.003(19.5 - 13.45)}{13.45} = 0.00135 \end{aligned}$$

Since  $\varepsilon_t < 0.002$ , then  $\phi = 0.65$ .

$$\phi P_n = 0.65(612.9) = 398.4 \text{ K}$$

$$\phi M_n = 0.65(510.8) = 332 \text{ K} \cdot \text{ft}$$

### 11.8.2 Numerical Analysis Solution

The analysis of columns when compression controls can also be performed by reducing the calculations into one cubic equation in the form

$$Aa^3 + Ba^2 + Ca + D = 0$$

and then solving for  $a$  by a numerical method, or  $a$  can be obtained directly by using one of many inexpensive scientific calculators with built-in programs that are available. From the equations of equilibrium,

$$\begin{aligned} P_n &= C_c + C_s - T \\ &= (0.85f'_c ab) + A'_s(f_y - 0.85f'_c) - A_s f_s \end{aligned} \quad (\text{Eq. 11.10})$$

Taking moments about the tension steel,  $A_s$ ,

$$\begin{aligned} P_n &= \frac{1}{e'} \left[ C_c \left( d - \frac{a}{2} \right) + C_s (d - d') \right] \\ &= \frac{1}{e'} \left[ 0.85f'_c ab \left( d - \frac{a}{2} \right) + A'_s (f_y - 0.85f'_c) (d - d') \right] \end{aligned} \quad (\text{Eq. 11.11})$$

From the strain diagram,

$$\varepsilon_s = \left( \frac{d_t - c}{c} \right) (0.003) = \frac{(d - a/\beta_1)}{a/\beta_1} (0.003)$$

The stress in the tension steel is

$$f_s = \varepsilon_s E_s = 29,000 \varepsilon_s = \frac{87}{a} (\beta_1 d - a)$$

Substituting this value of  $f_s$  in Eq. 11.10 and equating Eqs. 11.10 and Eqs. 11.11 and simplifying gives

$$\begin{aligned} \left( \frac{0.85f'_c b}{2} \right) a^3 + [0.85f'_c b(e' - d)]a^2 + [A'_s(f_y - 0.85f'_c)(e' - d + d') + 87A_s e']a \\ - 87A_s e' \beta_1 d = 0 \end{aligned}$$

This is a cubic equation in terms of  $a$ :

$$Aa^3 + Ba^2 + Ca + D = 0$$

where

$$A = \frac{0.85f'_c}{b2}$$

$$B = 0.85f'_c b(e' - d)$$

$$C = A'_s(f_y - 0.85f'_c)(e' - d + d') + 87A_s e'$$

$$D = -87 A_s e' \beta_1 d$$

Once the values of  $A$ ,  $B$ ,  $C$ , and  $D$  are calculated,  $a$  can be determined by trial or directly by a scientific calculator. Also, the solution of the cubic equation can be obtained by using the well-known Newton–Raphson method. This method is very powerful for finding a root of  $f(x) = 0$ . It involves a simple technique, and the solution converges rapidly by using the following steps:

1. Let  $f(a) = Aa^3 + Ba^2 + Ca + D$ , and calculate  $A$ ,  $B$ ,  $C$ , and  $D$ .
2. Calculate the first derivative of  $f(a)$ :

$$f'(a) = 3Aa^2 + 2Ba + C$$

3. Assume any initial value of  $a$ , say,  $a_0$ , and compute the next value:

$$a_1 = a_0 - \frac{f(a_0)}{f'(a_0)}$$

4. Use the obtained value  $a_1$  in the same way to get

$$a_2 = a_1 - \frac{f(a_1)}{f'(a_1)}$$

5. Repeat the same steps to get the answer up to the desired accuracy. In the case of the analysis of columns when compression controls, the value  $a$  is greater than the balanced  $a(a_b)$ . Therefore, start with  $a_0 = a_b$  and repeat twice to get reasonable results.

### Example 11.5

Repeat Example 11.4 using numerical solution.

#### Solution

1. Calculate  $A$ ,  $B$ ,  $C$ , and  $D$  and determine  $f(a)$ :

$$A = 0.85 \times 4 \times \frac{14}{2} = 23.8$$

$$B = 0.85 \times 4 \times 14(18.5 - 19.5) = -47.6$$

$$\begin{aligned} C &= 4(60 - 0.85 \times 4)(18.5 - 19.5 + 2.5) + 87 \times 4 \times 18.5 \\ &= 6777.6 \end{aligned}$$

$$D = -87 \times 4 \times 18.5 \times (0.85 \times 19.5) = -106,710$$

$$f(a) = 23.8a^3 - 47.6a^2 + 6777.6a - 106,710$$

2. Calculate the first derivative:

$$f'(a) = 71.4a^2 - 95.2a + 6777.6$$

3. Let  $a_0 = a_b = 9.81$  in. For a balanced section,  $c_b = 11.54$  in. and  $a_b = 9.81$  in.

$$a_1 = 9.81 - \frac{f(9.81)}{f'(9.81)} = 9.81 - \frac{-22,334}{12,715} = 11.566 \text{ in.}$$

4. Calculate  $a_2$ :

$$a_2 = 11.566 - \frac{f(11.566)}{f'(11.566)} = 11.566 - \frac{2136}{15,228} = 11.43 \text{ in.}$$

This value of  $a$  is similar to that obtained earlier in Example 11.3. Substitute the value of  $a$  in Eq. 11.3 or 11.11 to get  $P_n = 612.9$  K.

### 11.8.3 Approximate Solution

An approximate equation was suggested by Whitney to estimate the nominal compressive strength of short columns when compression controls, as follows [15]:

$$P_n = \frac{bhf'_c}{3he/d^2 + 1.18} + \frac{A'_s f_y}{e/(d - d') + 0.5} \quad (11.20)$$

This equation can be used only when the reinforcement is symmetrically placed in single layers parallel to the axis of bending.

A second approximate equation was suggested by Hsu [16]:

$$\frac{P_n - P_b}{P_0 - P_b} + \left( \frac{M_n}{M_b} \right)^{1.5} = 1.0 \quad (11.21)$$

where

- $P_n$  = nominal axial strength of the column section
- $P_b, M_b$  = nominal load and moment of the balanced section
- $M_n$  = nominal bending moment =  $P_n e$
- $P_0$  = nominal axial load at  $e = 0$   
 $= 0.85f'_c(A_g - A_{st}) + A_{st}f_y$
- $A_g$  = gross area of the section =  $bh$
- $A_{st}$  = total area of nonprestressed longitudinal reinforcement

### Example 11.6

Determine the nominal compressive strength,  $P_n$ , for the section given in Example 11.4 by Eqs. 11.20 and Eqs. 11.21 using the same eccentricity,  $e = 10$  in., and compare results.

#### Solution

1. Solution by Whitney equation (Eq. 11.20):

- a. Properties of the section shown in Fig. 11.10 are  $b = 14$  in.,  $h = 22$  in.,  $d = 19.5$  in.,  $d' = 2.5$  in.,  $A'_s = 4.0$  in.<sup>2</sup>, and  $d - d' = 17$  in.

- b. Apply the Whitney equation:

$$P_n = \frac{14 \times 22 \times 4}{(3 \times 22 \times 10)/(19.5)^2 + 1.18} = \frac{4 \times 60}{(10/17) + 0.5} = 643 \text{ K}$$

$$\phi P_n = 0.65 P_n = 418 \text{ K}$$

- c. Then  $P_n$  calculated by the Whitney equation is not a conservative value in this example, and the value of  $P_n = 643$  K is greater than the more accurate value of 612.9 K calculated by statics in Example 11.4.
2. Solution by Hsu equation (Eq. 11.21):
- For a balanced condition,  $P_b = 453.4$  K and  $M_b = 6810.8$  K · in. (Example 11.2).
  - $P_0 = 0.85f'_c(A_g - A_{st}) + A_{st}f = 0.85(4)(14 \times 22 - 8) + 8(60) = 1500$  K
  - $\frac{P_n - 453.4}{1500 - 453.4} + \left(\frac{10P_n}{6810.8}\right)^{1.5} = 1$   
Multiply by 1000 and solve for  $P_n$ .

$$0.9555P_n + 0.05626P_n^{1.5} = 1433.2 \text{ K}$$

By trial,  $P_n = 611$  K, which is very close to 612.9 K, as calculated by statics.

## 11.9 INTERACTION DIAGRAM EXAMPLE

In Example 11.2, the balanced loads  $P_b$ ,  $M_b$ , and  $e_b$  were calculated for the section shown in Fig. 11.6 ( $e_b = 15$  in.). Also, in Examples 11.3 and 11.4, the load capacity of the same section was calculated for the case when  $e = 20$  in. (tension failure) and when  $e = 10$  in. (compression failure). These values are shown in Table 11.1.

To plot the load–moment interaction diagram, different values of  $\phi P_n$  and  $\phi M_n$  were calculated for various  $e$  values that varied between  $e = 0$  and  $e = \text{maximum}$  for the case of pure moment when  $P_n = 0$ . These values are shown in Table 11.1. The interaction diagram is shown in Fig. 11.11. The load  $\phi P_{n0} = 975$  K represents the theoretical axial load when  $e = 0$ , whereas  $0.8\phi P_{n0} = 780$  K represents the maximum axial load allowed by the ACI Code based on minimum eccentricity. Note that for compression failure,  $e < e_b$  and  $P_n > P_b$ , and for tension failure,  $e > e_b$  and  $P_n < P_b$ . The last

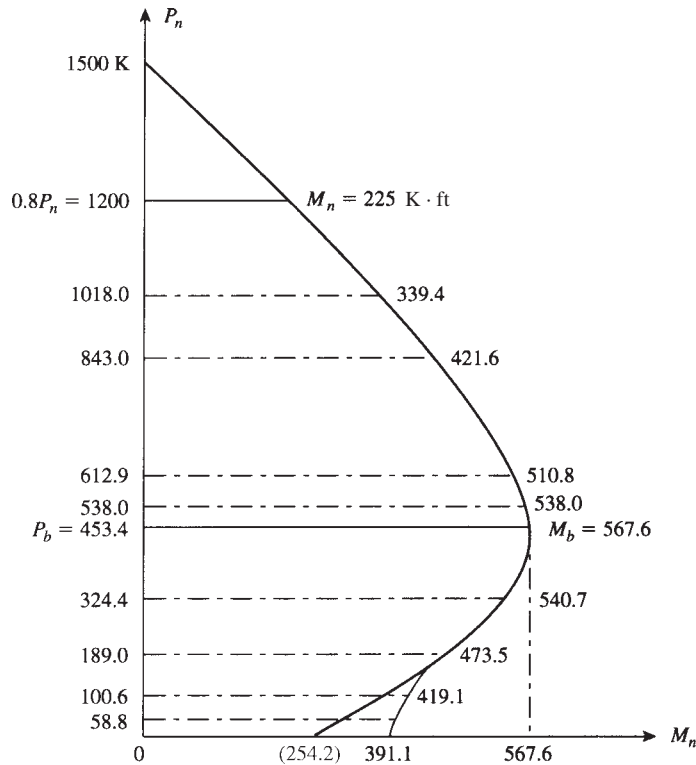
**Table 11.1** Summary of Load Strength of Column Section in Previous Examples

$e$ (in.)	$a$ (in.)	$\phi$	$P_n$ (K)	$\phi P_n$ (K)	$\phi M_n$ (K · ft)	Notes
0	—	0.65	1500	975	0.0	$\phi P_{n0}$
2.25	19.39	0.65	1200	780	146.3	$0.8\phi P_{n0}$
4	16.82	0.65	1018	661.7	220.6	Compression
6	14.19	0.65	843.3	548.1	274.0	Compression
10 <sup>a</sup>	11.43	0.65	612.9	398.4	332.0	Compression
12	10.63	0.65	538.0	349.7	349.7	Compression
15 <sup>a</sup>	9.81	0.65	453.4	294.7	368.9	Balanced
20 <sup>a</sup>	7.10	0.81	324.4	263.4	439.0	Transition
30	5.06	0.90	189.4	170.5	426.2	Tension
50	4.01	0.90	100.6	90.5	377.2	Tension
80	3.59	0.90	58.8	52.9	352.0	Tension
PM <sup>b</sup>	3.08	0.90	0.0	0.0	352.0	Tension
PM	3.08	0.65	0.0	0.0	254.2	PM (X) <sup>c</sup>

<sup>a</sup>Values calculated in Examples 11.2, 11.3 and 11.4.

<sup>b</sup>PM is pure moment.

<sup>c</sup>X indicates not applicable, for comparison only.



**Figure 11.11** Interaction diagram of the column section shown in Fig. 11.10.

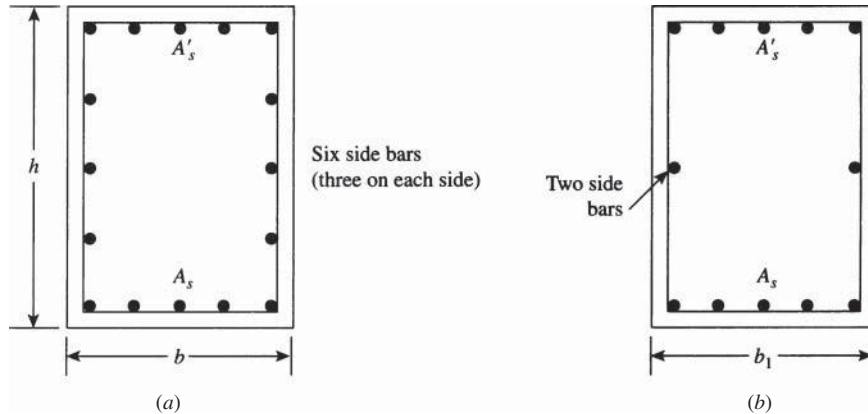
two cases in the table represent the pure moment (PM) or beam-action case for  $\phi = 0.9$  and  $\phi = 0.65$  ( $M_n = 391 \text{ K} \cdot \text{ft}$ ). To be consistent with the design of beams due to bending moments, the ACI Code allows the use of  $\phi = 0.9$  with pure moment, so  $\phi M_n = 352 \text{ K} \cdot \text{ft}$  instead of  $254.2 \text{ K} \cdot \text{ft}$ . Also note that  $\phi$  varies between 0.65 and 0.9 according to Eq. 11.2 for tied columns. Note that  $M_n = 391.1 \text{ K} \cdot \text{ft}$ .

## 11.10 RECTANGULAR COLUMNS WITH SIDE BARS

In some column sections, the steel reinforcement bars are distributed around the four sides of the column section. The side bars are those placed on the sides along the depth of the section in addition to the tension and compression steel,  $A_s$  and  $A'_s$ , and can be denoted by  $A_{ss}$  (Fig. 11.12). In this case, the same procedure explained earlier can be applied, taking into consideration the strain variation along the depth of the section and the relative force in each side bar either in the compression or tension zone of the section. These are added to those of  $C_c$ ,  $C_s$ , and  $T$  to determine  $P_n$  and Eq. 11.10 becomes

$$P_n = C_c + \Sigma C_s - \Sigma T \quad (11.10a)$$

Example 11.7 explains this analysis. Note that if the side bars are located near the neutral axis (Fig. 11.12b), the strains—and, consequently, the forces—in these bars are very small and can be neglected. Those bars close to  $A_s$  and  $A'_s$  have appreciable force and increase the load capacity of the section.



**Figure 11.12** Side bars in rectangular sections: (a) six side bars and (b) two side bars (may be neglected).

### Example 11.7

Determine the balanced load,  $P_b$ , moment,  $M_b$ , and  $e_b$  for the section shown in Fig. 11.13. Use  $f'_c = 4$  ksi and  $f_y = 60$  ksi.

### Solution

The balanced section is similar to Example 11.2. Given:  $b = h = 22$  in.,  $d = 19.5$  in.,  $d' = 2.5$  in.,  $A_s = A'_s = 6.35$  in.<sup>2</sup> (five no. 10 bars), and six no. 10 side bars (three on each side).

1. Calculate the distance to the neutral axis:

$$c_b = \left( \frac{87}{87 + f_y} \right) d_t = \left( \frac{87}{87 + 60} \right) 19.5 = 11.54 \text{ in.}$$

$$a_b = 0.85(11.54) = 9.81 \text{ in.}$$

2. Calculate the forces in concrete and steel bars; refer to Fig. 11.13a. In the compression zone,  $C_c = 0.85f'_c ab = 0.85(4)(9.81)(22) = 733.8$  K.

$$f'_s = 87 \left( \frac{c - d'}{c} \right) = 87 \left( \frac{11.54 - 2.5}{11.54} \right) = 68.15 \text{ ksi} > 60 \text{ ksi}$$

Then  $f'_s = 60$  ksi.

$$C_{s1} = A'_s(f_y - 0.85f'_c) = 6.35(60 - 0.85 \times 4) = 359.4 \text{ K}$$

$$f_{s2} = 87 \left( \frac{11.54 - 2.5 - 4.25}{11.54} \right) = 36.11 \text{ ksi}$$

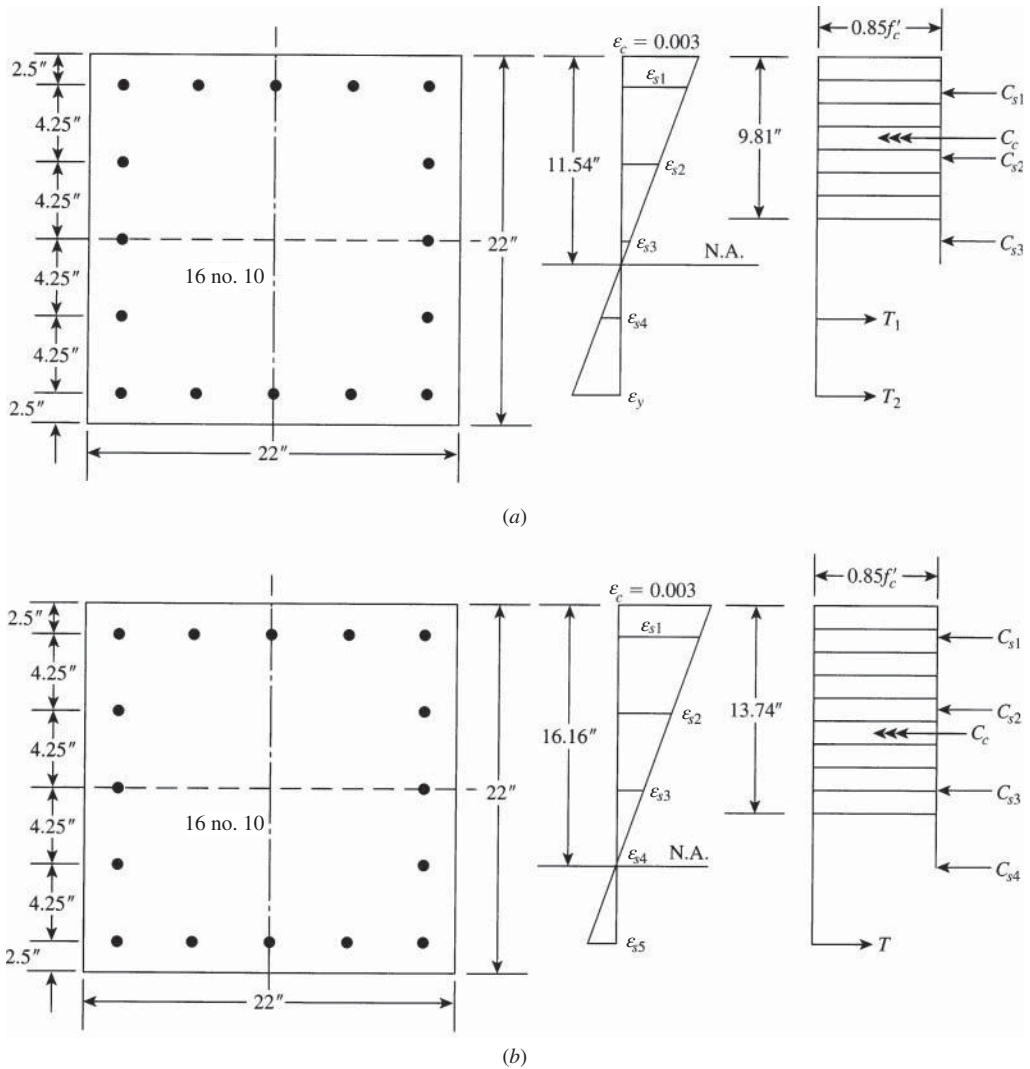
$$C_{s2} = 2(1.27)(36.11 - 0.85 \times 4) = 83.1 \text{ K}$$

Similarly,  $f_{s3} = 4.07$  ksi and  $C_{s3} = 2(1.27)(4.07 - 0.85 \times 4) = 1.7$  K.

In the tension zone,

$$\epsilon_{s4} = 964.50 \times 10^{-6} \quad f_{s4} = 28 \text{ ksi}$$

$$T_1 = 2(1.27)(28) = 71 \text{ K} \quad T_2 = A_s f_y = 6.35(60) = 381 \text{ K}$$



**Figure 11.13** (a) Example 11.7: Balanced section. (b) Example 11.8: For compression failure,  $e = 6$  in.

3. Calculate  $P_b = C_c + \Sigma C_s - \Sigma T$ .

$$\begin{aligned} P_b &= 733.8 + (359.4 + 83.1 + 1.7) - (71 + 381) \\ &= 726 \text{ K} \end{aligned}$$

4. Taking moments about the plastic centroid,

$$\begin{aligned} M_b &= 733.8(6.095) + 359.4(8.5) + 83.1(4.25) + 71(4.25) + 381(8.5) \\ &= 11,421 \text{ K} \cdot \text{in.} = 952 \text{ K} \cdot \text{ft} \end{aligned}$$

$$e_b = \frac{M_b}{P_b} = 15.735 \text{ in.}$$

5. Determine  $\phi$ : For a balanced section,  $\epsilon_t = \epsilon_y = 0.002$ ,  $\phi = 0.65$ ,

$$\phi P_b = 0.65P_b = 472 \text{ K} \quad \text{and} \quad \phi M_b = 0.65M_b = 618.8 \text{ K} \cdot \text{ft}$$

### Example 11.8

Repeat the previous example when  $e = 6.0$  in.

### Solution

1. Because  $e = 6$  in.  $< e_b = 15.735$  in., this is a compression failure condition. Assume  $c = 16.16$  in. (by trial) and  $a = 0.85(16.16) = 13.74$  in. (Fig. 11.13b).
2. Calculate the forces in concrete and steel bars:

$$C_c = 0.85(4)(13.74)(22) = 1027.75 \text{ K}$$

In a similar approach to the balanced case,  $f_{s1} = 60$  ksi and  $C_{s1} = 359.41$ .

$$f_{s2} = 50.66 \text{ ksi} \quad C_{s2} = 120.0 \text{ K}$$

$$f_{s3} = 27.78 \text{ ksi} \quad C_{s3} = 61.92 \text{ K}$$

$$f_{s4} = 4.9 \text{ ksi} \quad C_{s4} = 3.81 \text{ K}$$

$$f_{s5} = 18 \text{ ksi} \quad T = 6.35(18) = 114.2 \text{ K}$$

3. Calculate  $P_n = C_c + \Sigma C_s - \Sigma T = 1458.7 \text{ K}$ .

$$M_n = P_n e = 729.35 \text{ K} \cdot \text{ft} \quad (e = 6 \text{ in.})$$

4. Check  $P_n$  by taking moments about  $A_s$ ,

$$P_n = \frac{1}{e'} \left[ C_c \left( d - \frac{a}{2} \right) + C_{s1}(d - d') + C_{s2}(d - d' - s) \right. \\ \left. + C_{s3}(d - d' - 2s) + C_{s4}(d - d' - 3s) \right]$$

$$e' = e + d - \frac{h}{2} = 6 + 19.5 - 22/2 = 14.5 \text{ in.}$$

$s$  = distance between side bars

$$= 4.25 \text{ in.} \quad (s = \text{constant in this example.})$$

$$P_n = \frac{1}{14.5} \left[ 1027.75 \left( 19.5 - \frac{13.74}{2} \right) + 359.41(17) \right. \\ \left. + 120(17 - 4.25) + 61.92(17 - 8.5) \right. \\ \left. + 3.81(17 - 12.75) \right] = 1459 \text{ K}$$

5. Calculate  $\phi$ :

$$d_t = d = 19.5 \text{ in.} \quad c = 16.16 \text{ in.}$$

$$\epsilon_t \text{ (at tension steel level)} = \frac{0.003(d_t - c)}{c} \\ = \frac{0.003(19.5 - 16.16)}{16.16} = 0.00062$$



Since  $\epsilon_t < 0.002$ , then  $\phi = 0.65$ .

$$\phi P_n = 0.65(1459) = 948.3 \text{ K}$$

$$\phi M_n = 0.65(729.5) = 474 \text{ K} \cdot \text{ft}$$

Note: If side bars are neglected, then

$$P_b = 733.8 + 359.4 - 381 = 712.2 \text{ K}$$

$$P_n(\text{at } e = 6 \text{ in.}) = 1027.75 + 359.4 - 114.2 = 1273 \text{ K}$$

If side bars are considered, the increase in  $P_b$  is about 2% and that in  $P_n$  is about 14.6%.

## 11.11 LOAD CAPACITY OF CIRCULAR COLUMNS

### 11.11.1 Balanced Condition

The values of the balanced load  $P_b$  and the balanced moment  $M_b$  for circular sections can be determined using the equations of equilibrium, as was done in the case of rectangular sections. The bars in a circular section are arranged in such a way that their distance from the axis of plastic centroid varies, depending on the number of bars in the section. The main problem is to find the depth of the compressive block  $a$  and the stresses in the reinforcing bars. The following example explains the analysis of circular sections under balanced conditions. A similar procedure can be adopted to analyze sections when tension or compression controls.

#### Example 11.9

Determine the balanced load  $P_b$  and the balanced moment  $M_b$  for the 16-in. diameter circular spiral column reinforced with eight no. 9 bars shown in Fig. 11.14. Given:  $f'_c = 4 \text{ ksi}$  and  $f_y = 60 \text{ ksi}$ .

$$S = 8 - 2.5 = 5.5 \text{ in.}$$

$$S_1 = S \cos 22.5^\circ = 5.1 \text{ in.}$$

$$S_2 = S \cos 67.5^\circ = 2.1 \text{ in.}$$

$$d = 8 + 5.1 = 13.1 \text{ in.}$$

$$S_3 = 1.85 \text{ in.}$$

$$S_4 = 4.85 \text{ in.}$$

#### Solution

1. Because the reinforcement bars are symmetrical about the axis A–A passing through the center of the circle, the plastic centroid lies on that axis.
2. Determine the location of the neutral axis:

$$d_t = 13.1 \text{ in.} \quad \epsilon_y = \frac{f_y}{E_S} \quad (E_S = 29,000 \text{ ksi})$$

$$\frac{c_b}{d_t} = \frac{0.003}{0.003 + \epsilon_y} = \frac{0.003}{0.003 + f_y/E_S} = \frac{87}{87 + f_y}$$

$$c_b = \frac{87}{87 + 60}(13.1) = 7.75 \text{ in.}$$

$$a_b = 0.85 \times 7.75 = 6.59 \text{ in.}$$

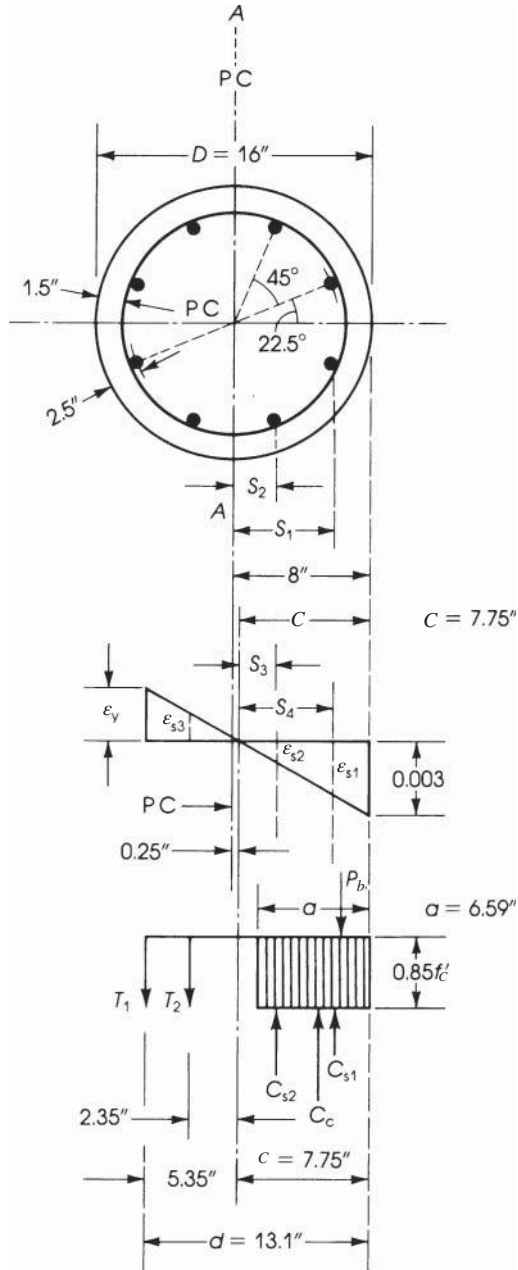


Figure 11.14 Example 11.9: Eight no. 9 bars.

3. Calculate the properties of a circular segment (Fig. 11.15):

$$\text{Area of segment} = r^2(\alpha - \sin \alpha \cos \alpha) \quad (11.22)$$

Location of centroid  $\bar{x}$  (from the circle center 0):

$$\bar{x} = \frac{2}{3} \frac{r \sin^3 \alpha}{\alpha - \sin \alpha \cos \alpha} \quad (11.23)$$

$$Z = r - \bar{x} \quad (11.24)$$

$$r \cos \alpha = r - a \quad \text{or} \quad \cos \alpha = \left(1 - \frac{a}{r}\right) \quad (11.25)$$

Then

$$\cos \alpha = \left(1 - \frac{6.59}{8}\right) = 0.176$$

and  $\alpha = 79.85^\circ$ ,  $\sin \alpha = 0.984$ , and  $\alpha = 1.394$  rad.

$$\begin{aligned} \text{Area of segment} &= (8)^2(1.394 - 0.984 \times 0.176) \\ &= 78.12 \text{ in.}^2 \end{aligned}$$

$$\bar{x} = \left(\frac{2}{3}\right) \frac{8(0.984)^3}{1.394 - 0.984 \times 0.176} = 4.16 \text{ in.}$$

$$Z = r - \bar{x} = 8 - 4.16 = 3.84 \text{ in.}$$

4. Calculate the compressive force  $C_c$ :

$$\begin{aligned} C_c &= 0.85f'_c \times \text{area of segment} \\ &= 0.85 \times 4 \times 78.12 = 265.6 \text{ K} \end{aligned}$$

It acts at 4.16 in. from the center of the column.

5. Calculate the strains, stresses, and forces in the tension and the compression steel. Determine the strains from the strain diagram. For  $T_1$ ,

$$\epsilon = e_y = 0.00207 \quad f_s = f_y = 60 \text{ ksi}$$

$$T_1 = 2 \times 60 = 120 \text{ K}$$

For  $T_2$ ,

$$\epsilon_{s3} = \frac{2.35}{5.35} \epsilon_y = \frac{2.35}{5.35} \times 0.00207 = 0.00091$$

$$f_{s3} = 0.00091 \times 29,000 = 26.4 \text{ ksi}$$

$$T_2 = 26.4 \times 2 = 52.8 \text{ K}$$

For  $C_{s1}$ ,

$$\epsilon_{s1} = \frac{4.85}{7.75} \times 0.003 = 0.000188$$

$$f_{s1} = 0.000188 \times 29,000 = 54.5 \text{ ksi} < 60 \text{ ksi}$$

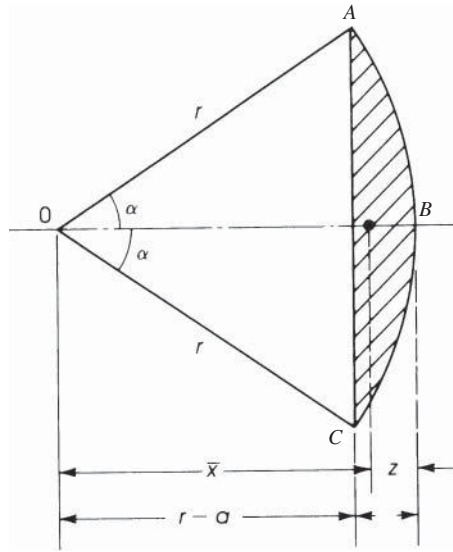
$$C_{s1} = 2(54.5 - 3.4) = 102.2 \text{ K}$$

For  $C_{s2}$

$$\epsilon_{s2} = \frac{1.85}{7.75} \times 0.003 = 0.000716$$

$$f_{s2} = 0.000716 \times 29,000 = 20.8 \text{ ksi}$$

$$C_{s2} = 2(20.8 - 3.4) = 34.8 \text{ K}$$



**Figure 11.15** Example 11.9: Properties of circular segments.

The stresses in the compression steel have been reduced to take into account the concrete displaced by the steel bars.

6. The balanced force is  $P_b = C_c + \Sigma C_s - \Sigma T$  ( $\phi = 0.75$ ).

$$P_b = 265.6 + (102.2 + 34.8) - (120 + 52.8) = 230 \text{ K}$$

For a balanced section,

$$\epsilon_t = 0.002 \quad \text{and} \quad \phi = 0.65$$

$$\phi P_b = 149.5 \text{ K}$$

7. Take moments about the plastic centroid (axis A–A through the center of the section) for all forces:

$$\begin{aligned} M_b &= P_b e_b = C_c \times 4.16 + C_{s1} \times 5.1 + C_{s2} \times 2.1 + T_1 \times 5.1 + T_2 \times 2.1 \\ &= 2422.1 \text{ K} \cdot \text{in.} = 201.9 \text{ K} \cdot \text{ft} \end{aligned}$$

$$\phi M_b = 131.2 \text{ K} \cdot \text{ft}$$

$$e_b = \frac{2422.1}{230} = 10.5 \text{ in.}$$

### 11.11.2 Strength of Circular Columns for Compression Failure

A circular column section under eccentric load can be analyzed in similar steps as the balanced section. This is achieved by assuming a value for  $c > c_b$  or  $a > a_b$  and calculating the forces in concrete and steel at different locations to determine  $P_{n1}$   $P_{n1} = C_c + \Sigma C_s - \Sigma T$ . Also,  $M_n$  can be calculated by taking moments about the plastic centroid (center of the section) and determining

$P_{n2} = M_n/e$ . If they are not close enough, within about 1%, assume a new  $c$  or  $a$  and repeat the calculations. (See also Section 11.8.) Compression controls when  $e < e_b$  or  $P_n > P_b$ .

For example, if it is required to determine the load capacity of the column section of Example 11.9 when  $e = 6$  in.,  $P_n$  can be determined in steps similar to those of Example 11.9:

1. Because  $e = 6$  in. is less than  $e_b = 10.5$  in., compression failure condition occurs.
2. Assume  $c = 9.0$  in. (by trial)  $> c_b = 7.75$  in. and  $a = 7.65$  in.
3. Calculate  $\bar{x} = 3.585$  in.,  $Z = 4.415$  in., and the area of concrete segment = 94.93 in.<sup>2</sup>
4. Calculate forces: and  $C_c = 322.7$  K,  $C_{s1} = 110.7$  K,  $C_{s2} = 53.1$  K,  $T_1 = 21.6$  K, and  $T_2 = 78.9$  K.
5. Calculate  $P_{n1} = C_c + \Sigma C_s - \Sigma T = 386$  K.
6. Taking moments about the center of the column (plastic centroid):  $M_n = 191$  K · ft,  $P_{n2} = M_n/6 = 382$  K, which is close to  $P_{n1}$  (the difference is about 1%). Therefore,  $P_n = 382$  K. Note that if the column is spirally reinforced,  $\phi = 0.70$ .

An approximate equation for estimating  $P_n$  in a circular section when compression controls was suggested by Whitney [15]:

$$P_n = \frac{A_g f'_c}{9.6he/(0.8h + 0.67D_s)^2 + 1.18} + \frac{A_{st} f_y}{3e/D_s + 1} \quad (11.26)$$

where

- $A_g$  = gross area of section
- $H$  = diameter of section
- $D_s$  = diameter measured through centroid of bar arrangement
- $A_{st}$  = total vertical steel area
- $E$  = eccentricity measured from plastic centroid

### Example 11.10

Calculate the nominal compressive strength  $P_n$  for the section of Example 11.9 using the Whitney equation if the eccentricity is  $e = 6$  in.

#### Solution

1. Eccentricity  $e = 6$  in. is less than  $e_b = 10.5$  in., calculated earlier; thus, compression controls.
2. Using the Whitney equation,

$$A_g = \frac{\pi}{4} h^2 = \frac{\pi}{4} (16)^2 = 201.1 \text{ in.}^2$$

$$h = 16 \text{ in.} \quad D_s = 16 - 5 = 11.0 \text{ in.} \quad A_{st} = 8 \times 1 = 8 \text{ in.}^2$$

$$P_n = \frac{201.1 \times 4}{9.6 \times 16 \times 6 / (0.8 \times 16 + 0.67 \times 11)^2 + 1.18} + \frac{8 \times 60}{3 \times 6 / 11 + 1}$$

$$= 415.5 \text{ K}$$

3.  $M_n = P_n e = 415.5 \times \frac{6}{12} = 207.8$  K · ft. The value of  $P_n$  here is greater than  $P_n = 382$  K calculated earlier by statics.

### 11.11.3 Strength of Circular Columns for Tension Failure

Tension failure occurs in circular columns when the load is applied at an eccentricity  $e > e_b$ , or  $P_n < P_b$ . In this case, the column section can be analyzed in steps similar to those of the balanced section and Example 11.8. This is achieved by assuming  $c < c_b$  or  $a < a_b$  and then following the steps explained in Section 11.11.1. Note that because the steel bars are uniformly distributed along the perimeter of the circular section, the tension steel  $A_s$  provided could be relatively low, and the load capacity becomes relatively small. Therefore, it is advisable to avoid the use of circular columns for tension failure cases.

## 11.12 ANALYSIS AND DESIGN OF COLUMNS USING CHARTS

The analysis of column sections explained earlier is based on the principles of statics. For preliminary analysis or design of columns, special charts or tables may be used either to determine  $\phi P_n$  and  $\phi M_n$  for a given section or determine the steel requirement for a given load  $P_u$  and moment  $M_u$ . These charts and tables are published by the ACI [7], the Concrete Reinforcing Steel Institute (CRSI), and the Portland Cement Association (PCA). Final design of columns must be based on statics by using manual calculations or computer programs. The use of the ACI charts is illustrated in the following examples. The charts are given in Figs. 11.16 and 11.17 [7]. These data are limited to the column sections shown on the top-right corner of the charts.

---

### Example 11.11

Determine the necessary reinforcement for a short tied column shown in Fig. 11.18a to support a factored load of 483 K and a factored moment of 322 K · ft. The column section has a width of 14 in. and a total depth,  $h$ , of 20 in. Use  $f'_c = 5$  ksi,  $f_y = 60$  ksi.

### Solution

1. The eccentricity  $e = M_u/P_u = 322 \times 12/483 = 8$  in. Let  $d = 20 - 2.5 = 17.5$  in.,  $\gamma h = 20 - 2 \times 2.5 = 15$  in., and  $\gamma = 15/20 = 0.75$ .
2. Since  $e = 8$  in.  $< d$ , assume compression-controlled section with  $\phi = 0.65$ .

$$P_n = \frac{483}{0.65} = 743 \text{ K} \quad \text{and} \quad M_n = \frac{322}{0.65} = 495.4 \text{ K} \cdot \text{ft.}$$

$$K_n = \frac{743}{5 \times 14 \times 20} = 0.531$$

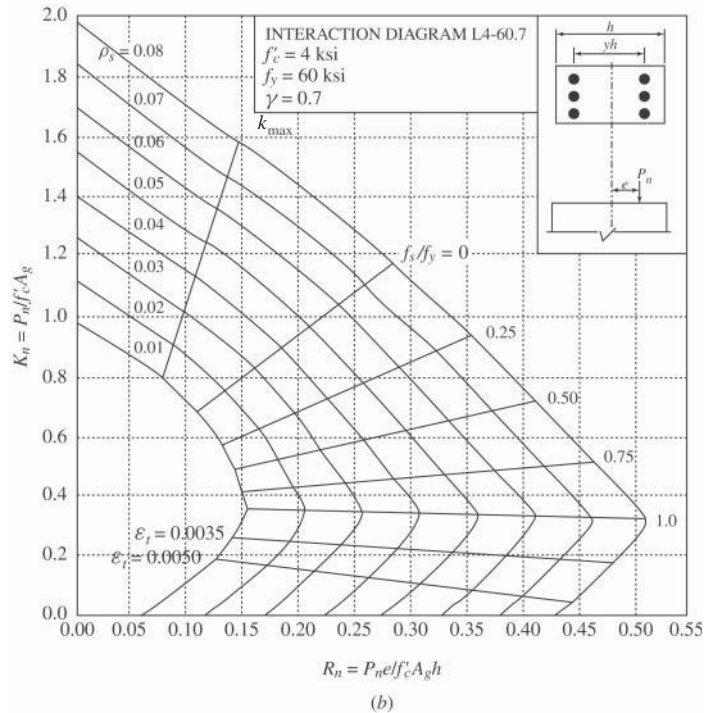
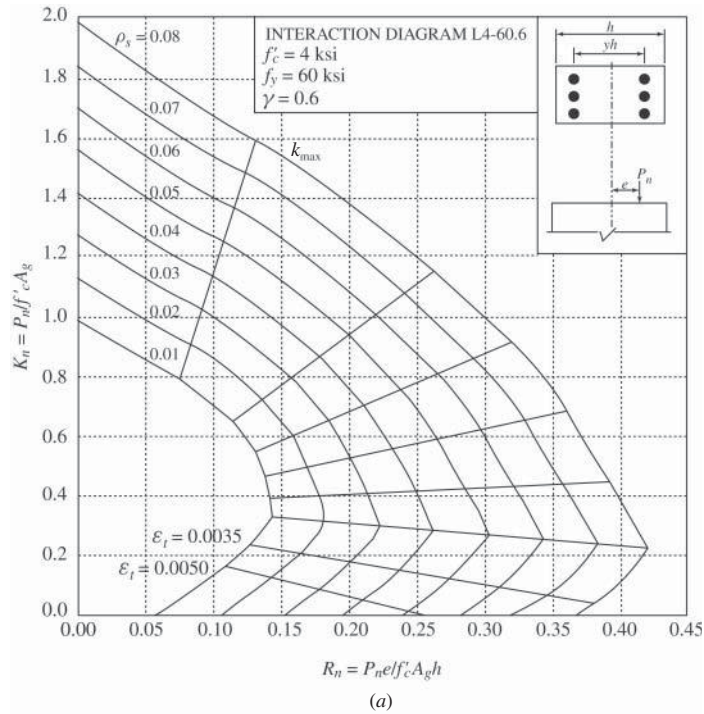
$$R_n = K_n \left( \frac{e}{h} \right) = 0.531 \left( \frac{8}{20} \right) = 0.212$$

3. From the charts of Fig. 11.17, for  $\gamma = 0.7$ ,  $\rho = 0.034$ . Also, for  $\gamma = 0.8$ ,  $\rho = 0.029$ . By interpolation, for  $\gamma = 0.75$ ,  $\rho = 0.0315$ .

$$A_s = 0.0315(14 \times 20) = 8.82 \text{ in.}^2$$

Use eight no. 10 bars ( $A_s = 10.16 \text{ in.}^2$ ), four on each short side. Use no. 3 ties spaced at 14 in. (Fig. 11.18a).

---



**Figure 11.16** Load–moment strength interaction diagram for rectangular columns where  $f'_c = 4$  ksi,  $f_y = 60$  ksi, and (a)  $\gamma = 0.60$ , (b)  $\gamma = 0.70$ , (c)  $\gamma = 0.80$ , and (d)  $\gamma = 0.90$ . Courtesy of American Concrete Institute [7].

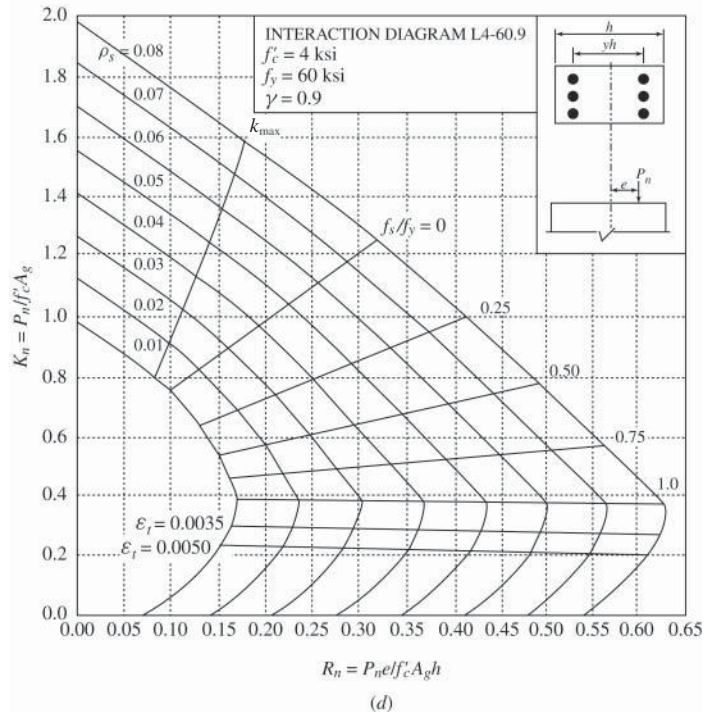
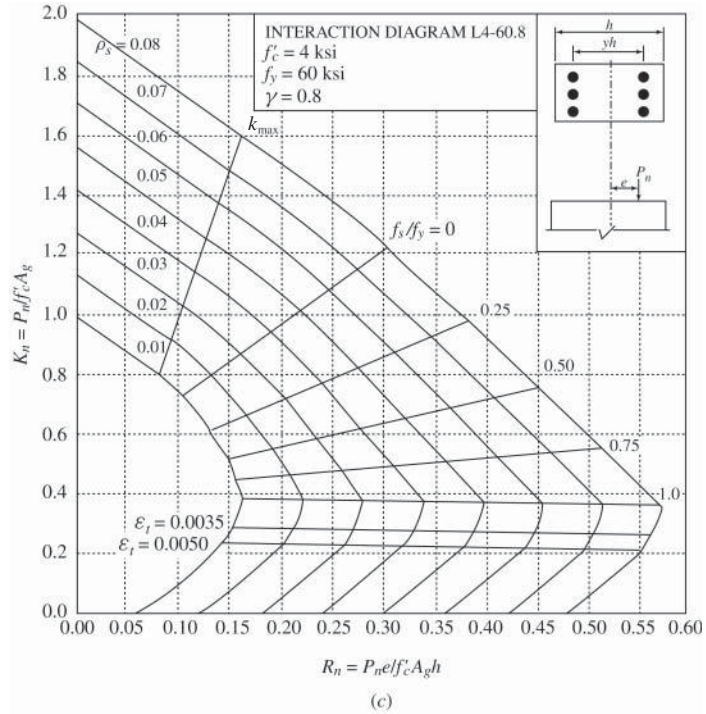
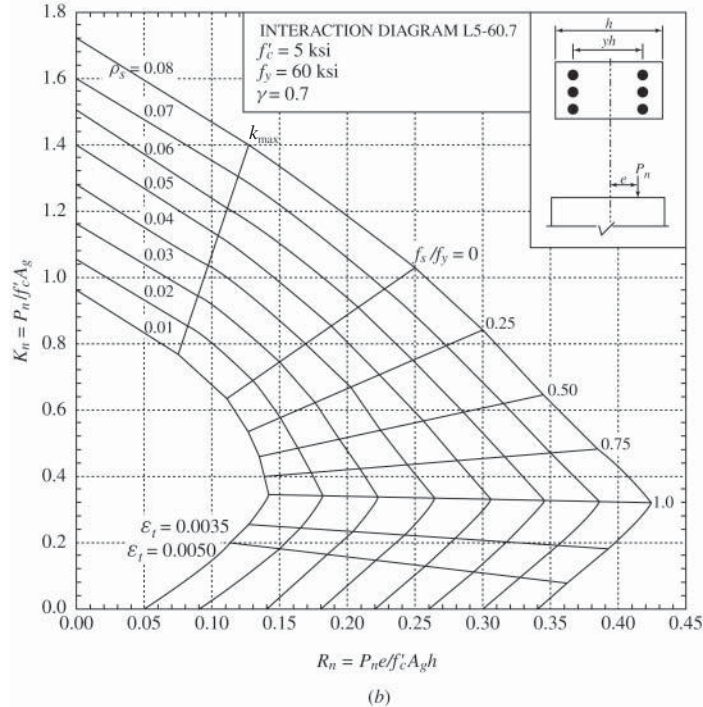
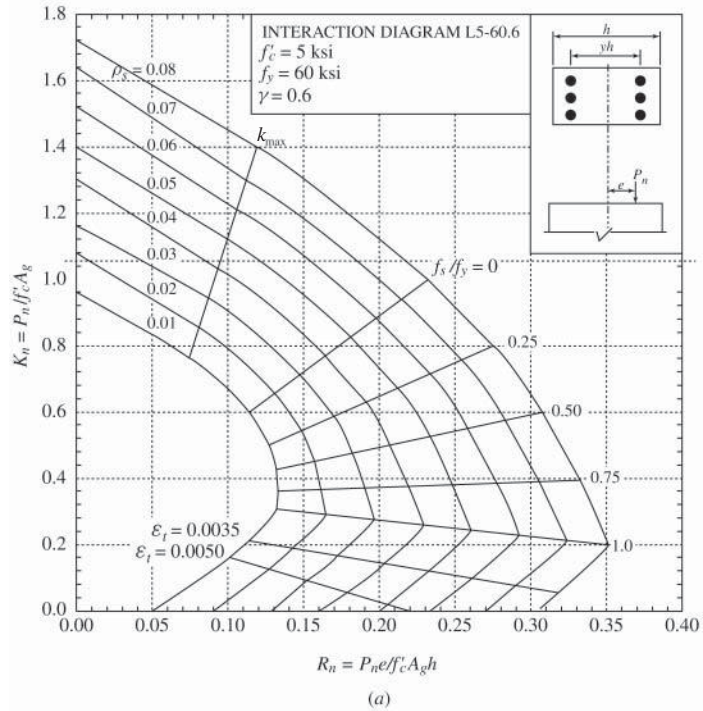


Figure 11.16 (Continued)





**Figure 11.17** Load–moment strength interaction diagram for rectangular columns where  $f'_c = 5$  ksi,  $f_y = 60$  ksi, and (a)  $\gamma = 0.60$ , (b)  $\gamma = 0.70$ , (c)  $\gamma = 0.80$ , and (d)  $\gamma = 0.90$ . Courtesy of American Concrete Institute [7].

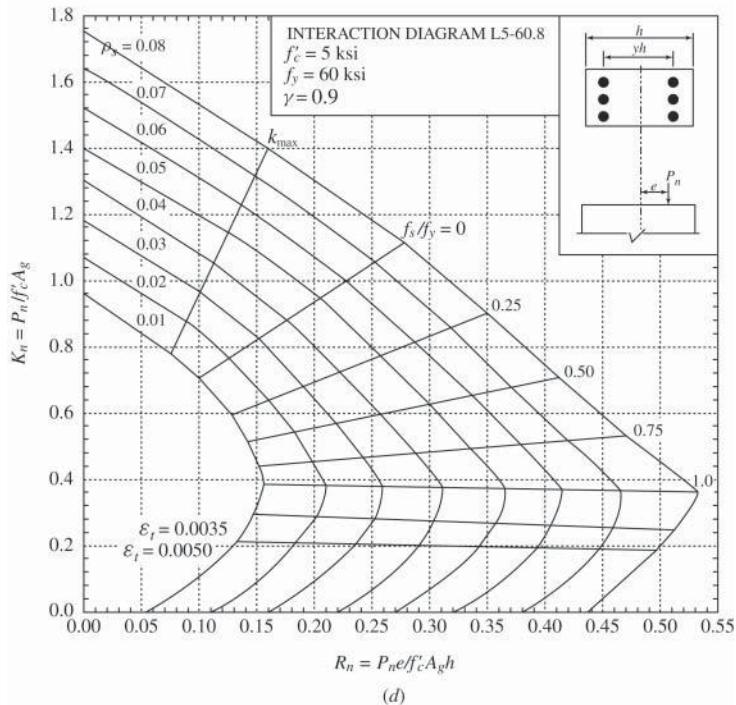
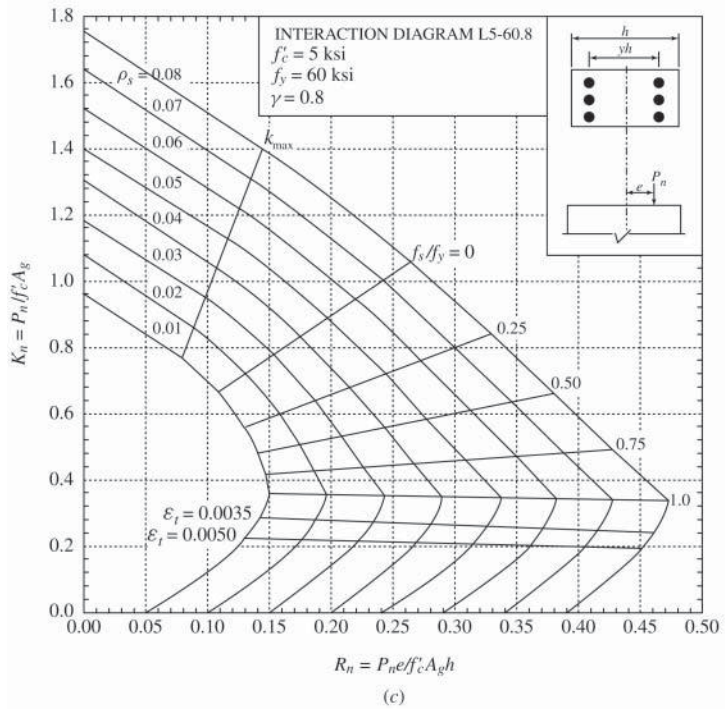
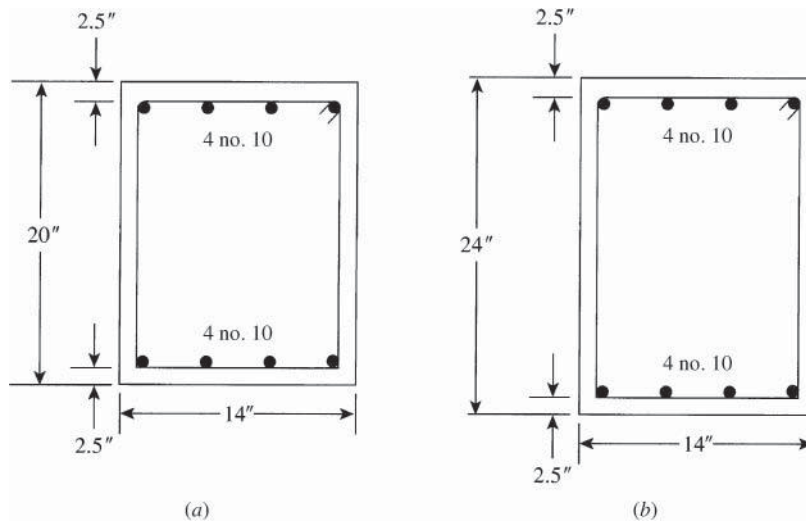


Figure 11.17 (Continued)



**Figure 11.18** Column sections of (a) Example 11.11 and (b) Example 11.12.

### Example 11.12

Use the charts to determine the column strength,  $\phi P_n$ , of the short column shown in Fig. 11.18b acting at an eccentricity  $e = 12$  in. Use  $f'_c = 5$  ksi and  $f_y = 60$  ksi.

### Solution

1. Properties of the section:  $H = 24$  in.,  $\gamma h = 24 - 2 \times 2.5 = 19$  in. (distance between tension and compression steel).  $\gamma = 19/24 = 0.79$ , and  $\rho = 8(1.27)/(14 \times 24) = 0.030$ .
2. Since  $e < d$ , assume compression-controlled section. Let  $\epsilon_t = 0.002$ ,  $f_s/f_y = 1.0$ , and  $\phi = 0.65$ . From the charts of Fig. 11.17, get  $K_n = 0.36 = P_n/(5 \times 14 \times 24)$ . Then  $P_n = 605$  K.
3. Check assumption for compression-controlled section: For  $K_n = 0.36$ ,  $R_n = K_n(e/h) = 0.36(12/24) = 0.18$ . From charts, get  $\rho = 0.018 < 0.03$ . Therefore,  $P_n > 605$  K (to use  $\rho = 0.03$ ).
4. Second trial: Let  $\epsilon_t = 0.0015$ ,  $f_s = 0.0015(29,000) = 43.5$  ksi.

$$\frac{f_s}{f_y} = \frac{43.5}{60} = 0.725 \quad \rho = 0.03 \quad K_n = 0.44$$

$$0.44 = \frac{P_n}{5 \times 14 \times 24} \quad P_n = 740 \text{ K}$$

5. Check assumption: For  $K_n = 0.44$ ,  $R_n = 0.44 \left( \frac{12}{24} \right) = 0.22$ . From charts,  $\rho = 0.03$  as given. Therefore,  $P_n = 740$  K.

$$\phi P_n = 0.65(740) = 480 \text{ K} \quad \text{and} \quad \phi M_n = 0.65(740) = 480 \text{ K} \cdot \text{ft}$$

By analysis,  $\phi P_n = 485$  K (which is close to 480 K · ft).

## 11.13 DESIGN OF COLUMNS UNDER ECCENTRIC LOADING

In the previous sections, the analysis, behavior, and the load–interaction diagram of columns subjected to an axial load and bending moment were discussed. The design of columns is more complicated because the external load and moment,  $P_u$  and  $M_u$ , are given and it is required to

determine many unknowns, such as  $b$ ,  $h$ ,  $A_s$ , and  $A'_s$ , within the ACI Code limitations. It is a common practice to assume a column section first and then determine the amount of reinforcement needed. If the designer needs to change the steel reinforcement calculated, then the cross section may be adjusted accordingly. The following examples illustrate the design of columns.

### 11.13.1 Design of Columns for Compression Failure

For compression failure, it is preferable to use  $A_s = A'_s$  for rectangular sections. The eccentricity,  $e$ , is equal to  $M_u/P_u$ . Based on the magnitude of  $e$ , two cases may develop.

1. When  $e$  is relatively very small (say,  $e \leq 4$  in.), a minimum eccentricity case may develop that can be treated by using Eq. 10, as explained in the examples of Chapter 10. Alternatively, the designer may proceed as in case 2. This loading case occurs in the design of the lower-floor columns in a multistory building, where the moment,  $M_u$ , develops from one floor system and the load,  $P_u$ , develops from all floor loads above the column section.
2. The compression failure zone represents the range from the axial to the balanced load, as shown in Figs. 11.3 and 11.11. In this case, a cross section ( $bh$ ) may be assumed and then the steel reinforcement is calculated for the given  $P_u$  and  $M_u$ . The steps can be summarized as follows:
  - a. Assume a square or rectangular section ( $bh$ ); then determine  $d$ ,  $d'$ , and  $e = M_u/P_u$ .
  - b. Assuming  $A_s = A'_s$ , calculate  $A'_s$  from Eq. 11.16 using the dimensions of the assumed section, and  $\phi = 0.65$  for tied columns. Let  $A_s = A'_s$  and then choose adequate bars. Determine the actual areas used for  $A_s$  and  $A'_s$ . Alternatively, use the ACI charts.
  - c. Check that  $\rho_g = (A_s + A'_s)/bh$  is less than or equal to 8% and greater or equal to 1%. If  $\rho_g$  is small, reduce the assumed section, but increase the section if less steel is required.
  - d. Check the adequacy of the final section by calculating  $\phi P_n$  from statics; as explained in the previous examples,  $\phi P_n$  should be greater than or equal to  $P_u$ .
  - e. Determine the necessary ties.

A simple approximate formula for determining the initial size of the column  $bh$  or the total steel ratio  $\rho_g$  is

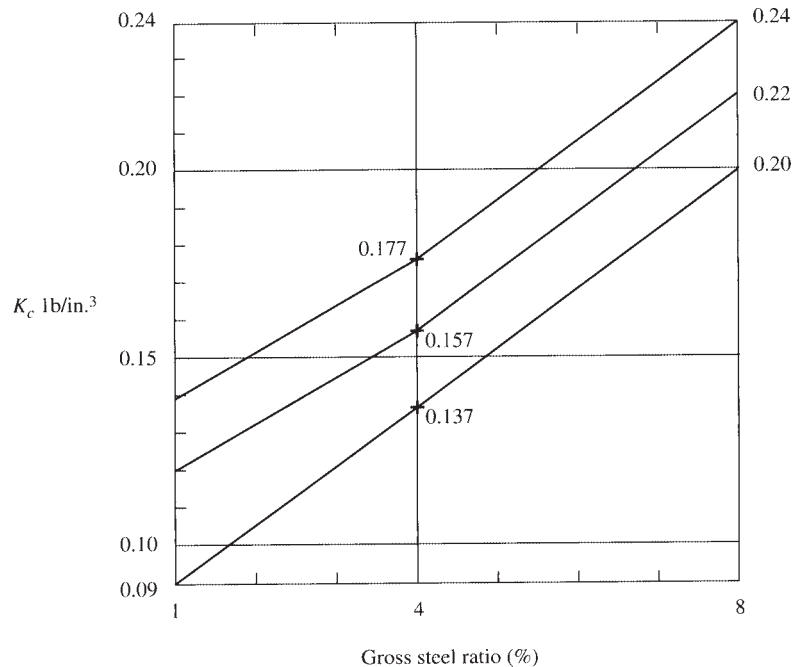
$$P_n = K_c b h^2 \quad \text{or} \quad P_u = \phi P_n = \phi K_c b h^2 \quad (11.27)$$

where  $K_c$  has the values shown in Table 11.2 and plotted in Fig. 11.19 for  $f_y = 60$  ksi and  $A_s = A'_s$ . Units for  $K_c$  are in lb/in.<sup>3</sup>

The values of  $K_c$  shown in Table 11.2 are approximate and easy to use because  $K_c$  increases by 0.02 for each increase of 1 ksi in  $f'_c$ . For the same section, as the eccentricity,  $e = M_u/P_u$ , increases,  $P_n$  decreases, and, consequently,  $K_c$  decreases. Thus,  $K_c$  values represent a load  $P_n$  on the interaction diagram between  $0.8 P_{n0}$  and  $P_b$  as shown in Fig. 11.3 or 11.11.

**Table 11.2** Values of  $K_c$  ( $f_y = 60$  ksi)

$\rho_g$ (%)	$K_c$		
	$f'_c = 4$ ksi	$f'_c = 5$ ksi	$f'_c = 6$ ksi
1	0.090	0.110	0.130
4	0.137	0.157	0.177
8	0.200	0.220	0.240



**Figure 11.19** Values of  $K_c$  versus  $\rho_g$  (%).

Linear interpolation can be used. For example,  $K_c = 0.1685$  for  $\rho_g = 6\%$  and  $f'_c = 4$  ksi. The steps in designing a column section can be summarized as follows:

1. Assume an initial size of the column section  $bh$ .
2. Calculate  $K_c = P_u/(\phi bh^2)$ .
3. Determine  $\rho_g$  from Table 11.2 for the given  $f'_c$ .
4. Determine  $A_s = A'_s = \rho_g bh/2$  and choose bars and ties.
5. Determine  $\phi P_n$  of the final section by statics (accurate solution). The value of  $\phi P_n$  should be greater than or equal to  $P_u$ . If not, adjust  $bh$  or  $\rho_g$ .

Alternatively, if a specific steel ratio is desired, say  $\rho_g = 6\%$ , then proceed as follows:

1. Assume  $\rho_g$  as required and then calculate  $e = M_u/P_u$ .
2. Based on the given  $f'_c$  and  $\rho_g$ , determine  $K_c$  from Table 11.2.
3. Calculate  $bh^2 = P_u/\phi K_c$ ; then choose  $b$  and  $h$ . Repeat steps 4 and 5. It should be checked that  $\rho_g$  is less than or equal to  $8\%$  and greater than or equal to  $1\%$ . Also, check that  $c$  calculated by statics is greater than  $c_b = 87d_t/(87 + f_y)$  for compression failure to control.

---

### Example 11.13

Determine the tension and compression reinforcement for a  $16 \times 24$ -in. rectangular tied column to support  $P_u = 780$  K and  $M_u = 390$  K · ft. Use  $f'_c = 4$  ksi and  $f_y = 60$  ksi.

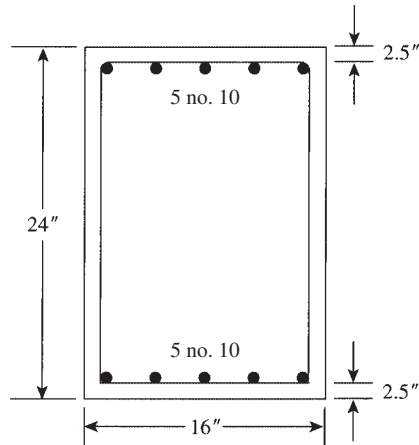


Figure 11.20 Example 11.13.

### Solution

1. Calculate  $e = M_u/P_u = 420(12)/840 = 6.0$  in. We have  $h = 24$  in; let  $d = 21.5$  in. and  $d' = 2.5$  in. Because  $e$  is less than  $\frac{2}{3}d = 14.38$  in., assume compression failure.
2. Assume  $A_s = A'_s$  and use Eq. 11.20 to determine the initial value of  $A'_s$ ,  $P_n = P_u/\phi = 780/0.65 = 1200$  K.

$$P_n = \frac{bf_c'}{(3he/d^2) + 1.18} + \frac{A'_s f_y}{[e/(d - d')] + 0.5} \quad (11.20)$$

For  $P_n = 1200$  K,  $e = 6$  in.,  $d = 21.5$  in.,  $d' = 2.5$  in., and  $h = 24$  in., calculate  $A'_s = 6.44$  in.<sup>2</sup> =  $A_s$ . Choose five no. 10 bars ( $A_s = 6.35$  in.<sup>2</sup>) for  $A_s$  and  $A'_s$  (Fig. 11.20).

3. Let  $\rho_g = 2(6.35)/(16 \times 24) = 0.033$ , which is less than 0.08 and  $>0.01$ .
4. Check the section by statics following the steps of Example 11.4 to get

$$a = 16.64 \text{ in.} \quad c = 19.58 \text{ in.} \quad C_c = 905.2 \text{ K}$$

$$C_s = 6.35(60 - 0.85 \times 4) = 359.4 \text{ K}$$

$$f_s = 87 \left( \frac{d - c}{c} \right) = 8.55 \text{ ksi}$$

$$T = A_s f_s = 6.35(8.55) = 54.3 \text{ K}$$

$$P_n = C_c + C_s - T = 1210.3 \text{ K} > 1200 \text{ K}$$

Note that if  $\phi P_n < P_u$ , increase  $A_s$  and  $A'_s$ , for example, to six no. 10 bars, and check the section again.

5. Check  $P_n$  based on moments about  $A_s$  (Eq. 11.12) to get  $P_n = 1210$  K.
6. For a balanced section,

$$c_b = \left( \frac{87}{87 + f_y} \right) d_t = \left( \frac{87}{147} \right) 21.5 = 12.7 \text{ in.}$$

Because  $c = 19.58$  in.  $> c_b = 12.7$  in., this is a compression failure case, as assumed.

7. Use no. 3 ties spaced at 16 in (refer to Chapter 10).

**Example 11.14**

Repeat Example 11.13 using Eq. 11.27.

**Solution**

1. The column section is given:  $16 \times 24$  in.
2. Determine  $K_c$  from Eq. 11.27:

$$K_c = \frac{P_u}{\phi b h^2} = \frac{780}{0.65 \times 16 \times 24^2} = 0.13 \text{ lb/in.}^3$$

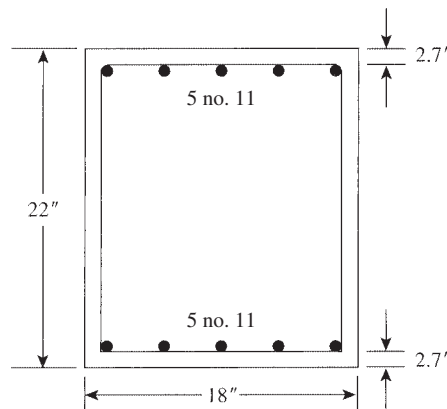
3. From Table 11.2 or Fig. 11.19, for  $K_c = 0.13$ ,  $f'_c = 4$  ksi, by interpolation, get  $\rho_g = 3.5\%$ .
4. Calculate  $A_s = A'_s = \rho b h / 2 = 0.035(16)(24)/2 = 6.77 \text{ in.}^2$ . Choose five no. 10 bars ( $A_s = 6.35 \text{ in.}^2$ ) for the first trial.
5. Determine  $\phi P_n$  using steps 4 to 7 in Example 11.13. Let  $\phi P_n = 1210.3 \text{ K} > P_n = 1200 \text{ K}$ , so the section is adequate.
6. If the section is not adequate, or  $\phi P_n < P_u$ , increase  $A_s$  and  $A'_s$  and check again to get closer values.

**Example 11.15**

Design a rectangular column section to support  $P_u = 696 \text{ K}$  and  $M_u = 465 \text{ K} \cdot \text{ft}$  with a total steel ratio  $\rho_g$  of about 4%. Use  $f'_c = 4$  ksi,  $f_y = 60$  ksi, and  $b = 18$  in.

**Solution**

1. Calculate  $e = M_u/P_u = 465(12)/696 = 8$  in. Assume compression failure ( $\phi = 0.65$ ) (to be checked later) and  $A_s = A'_s$ .
2. For  $\rho_s = 4\%$  and  $f'_c = 4$  ksi,  $K_c = 0.137$  (Table 11.2).
3. Calculate  $bh^2$  from Eq. 11.27:  $P_u = \phi K_c b h^2$ , or  $696 = 0.65(0.137)(18)h^2$ . Thus,  $h = 20.84$  in. Let  $h = 22$  in.
4. Calculate  $A_s = A'_s = 0.04(18 \times 22)/2 = 7.92 \text{ in.}^2$ . Choose five no. 11 bars ( $A_s = 7.8 \text{ in.}^2$ ) in one row for  $A_s$  and  $A'_s$  (Fig. 11.21). Choose no. 4 ties spaced at 18 in.
5. Check the final section by analysis, similar to Example 11.4, to get  $a = 13.15$  in.,  $c = 15.47$  in.,  $C_c = 0.85 f'_c ab = 804.8 \text{ K}$ ,  $f'_s = 60$  ksi,  $C_s = A'_s(f_y - 0.85f'_c) = 441.5 \text{ K}$ ,  $f_s = 87[(d - c)/c] = 21.24$  ksi, and  $T = A_s f_s = 168 \text{ K}$ . Also,  $P_n = C_c + C_s - T = 1078.3 \text{ K}$  and  $\phi P_n = 0.65 P_n = 701 \text{ K} > 696 \text{ K}$ . The section is adequate.



**Figure 11.21** Example 11.15.

6. For a balanced section,

$$c_b = \left( \frac{87}{87 + f_y} \right) \quad d_t = \left( \frac{87}{147} \right) 19.3 = 11.42 \text{ in.} < c = 15.47 \quad (d = 19.3 \text{ in.})$$

Therefore, this is a compression failure case, as assumed.

### 11.13.2 Design of Columns for Tension Failure

Tension failure occurs when  $P_n < P_b$  or the eccentricity  $e > e_b$ , as explained in Section 11.7. In the design of columns,  $P_u$  and  $M_u$  are given, and it is required to determine the column size and its reinforcement. It may be assumed (as a guide) that tension controls when the ratio of  $M_u$  (K · ft) to  $P_u$  (kips) is greater than 1.75 for sections of  $h < 24$  in. and 2.0 for  $h \geq 24$  in. In this case, a section may be assumed, and then  $A_s$  and  $A'_s$  are determined. The ACI charts may be used to determine  $\rho_g$  for a given section with  $A_s = A'_s$ . Note that  $\phi$  varies between 0.65 (0.75) and 0.9, as explained in Section 11.4.

When tension controls, the tension steel yields, whereas the compression steel may or may not yield. Assuming initially  $f'_s = f_y$  and  $A_s = A'_s$ , Eq. 11.16 (Section 11.6) may be used to determine the initial values of  $A_s$  and  $A'_s$ :

$$A_s = A'_s = \frac{P_n(e - h/2 + a/2)}{f_y(d - d')} \quad (11.16)$$

Because  $a$  is not known yet, assume  $a = 0.4d$  and  $P_u = \phi P_n$ ; then

$$A_s = A'_s = \frac{P_u(e - 0.5h + 0.2d)}{\phi f_y(d - d')} \quad (11.28)$$

The final column section should be checked by statics to prove that  $\phi P_n \geq P_u$ . Example 11.16 explains this approach.

When the load  $P_u$  is very small relative to  $M_u$ , the section dimensions may be determined due to  $M_u$  only, assuming  $P_u = 0$ . The final section should be checked by statics. This case occurs in single- or two-story building frames used mainly for exhibition halls or similar structures. In this case,  $A'_s$  may be assumed to be less than  $A_s$ . A detailed design of a one-story, two-hinged frame exhibition hall is given in Chapter 16.

#### Example 11.16

Determine the necessary reinforcement for a 16 × 22-in. rectangular tied column to support a factored load  $P_u = 257$  K and a factored moment  $M_u = 643$  K · ft. Use  $f'_c = 4$  ksi and  $f_y = 60$  ksi.

#### Solution

1. Calculate  $e = M_u/P_u = 643(12)/257 = 30$  in.; let  $d = 22 - 2.5 = 19.5$  in. Because  $M_u/P_u = 500/200 = 2.5 > 1.75$ , or because  $e > d$ , assume tension failure case,  $\phi = 0.9$  (to be checked later).
2. Assume  $A_s = A'_s$  and  $f'_s = f_y$  and use Eq. 11.28 to determine  $A_s$  and  $A'_s$ . Let  $P_u = 257.0$  K,  $e = 30$  in.,  $h = 22$  in.,  $d = 19.5$  in., and  $d' = 2.5$  in.

$$A_s = A'_s = \frac{257(30 - 0.5 \times 22 + 0.2 \times 19.5)}{0.9(60)(17.0)} = 6.41 \text{ in.}^2$$

Choose five no. 10 bars (6.35 in.<sup>2</sup>) in one row for each of  $A_s$  and  $A'_s$  (Fig. 11.22).

3. Check  $\rho_g = 2(6.35)(16 \times 22) = 0.036$ , which is less than 0.08 and greater than 0.01.



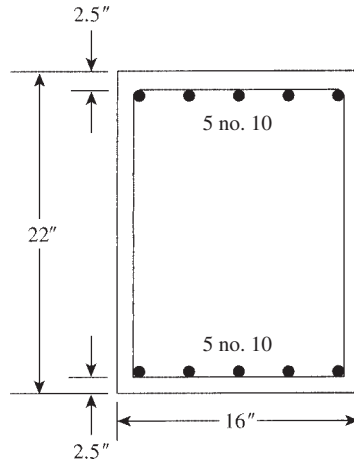


Figure 11.22 Example 11.16.

4. Check the chosen section by statics similar to Example 11.3.

- a. Determine the value of  $a$  using the general equation  $Aa^2 + Ba + C = 0$  with  $e' = e + d - h/2 = 38.5$  in.,  $A = 0.425 f'_c b = 27.2$ ,  $B = 2A(e' - d) = 1033.6$ ,  $C = A'_s(f_y - 0.85f'_c)(e' - d + d') - A_s f_y e' = -6941.2$ . Solve to get  $a = 5.82$  in. and  $c = a/0.85 = 6.85$ .

- b. Check  $f'_s$ :

$$f'_s = 87 \left( \frac{c - d'}{c} \right) = 87 \left( \frac{6.85 - 2.5}{6.85} \right) = 55.26 \text{ ksi}$$

$$\text{Let } f'_s = 57 \text{ ksi.}$$

- c. Recalculate  $a$ :

$$C = A'_s(f'_s - 0.85f'_c)(e' - d + d') - A_s f_y e' = -7351$$

Solve now for  $a$  to get  $a = 6.13$  and  $c = 7.21$  in.

- d. Check  $f'_s$ :

$$f'_s = 87 \left( \frac{c - 2.5}{c} \right) = 56.83 \text{ ksi}$$

Calculate

$$\begin{aligned} C_c &= 0.85(4)(6.13)(16) = 333.5 \text{ K} & C_s &= A'_s(f'_s - 0.85f'_c) = 6.35(57 - 0.85 \times 4) \\ &= 340.4 \text{ K} & T &= A_s f_y = 6.35(60) = 381 \text{ K} \end{aligned}$$

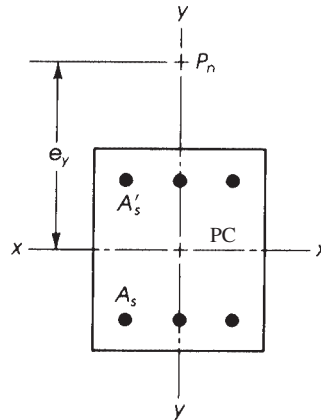
- e. Let  $P_n = C_c + C_s - T = 292.9 \text{ K}$ .

5. Determine  $\phi$ :  $\epsilon_t = [(d_t - c)/c] 0.003 = 0.00511$ . Because  $\epsilon_t = 0.00511 > 0.005$ ,  $\phi = 0.9$ .

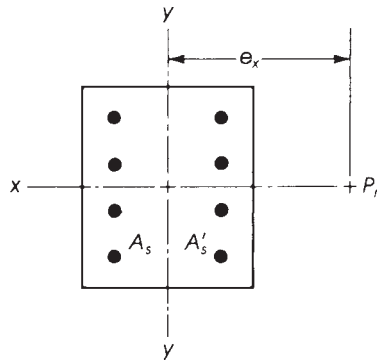
6. Because  $\phi P_n = 0.9(292.9) = 263.6 \text{ K} > 257 \text{ K}$ , the section is adequate.

## 11.14 BIAXIAL BENDING

The analysis and design of columns under eccentric loading was discussed earlier in this chapter, considering a uniaxial case. This means that the load  $P_n$  was acting along the  $y$ -axis (Fig. 11.23), causing a combination of axial load  $P_n$  and a moment about the  $x$ -axis equal to  $M_{nx} = P_n e_y$  or



**Figure 11.23** Uniaxial bending with load  $P_n$  along the  $y$ -axis with eccentricity  $e_y$ .

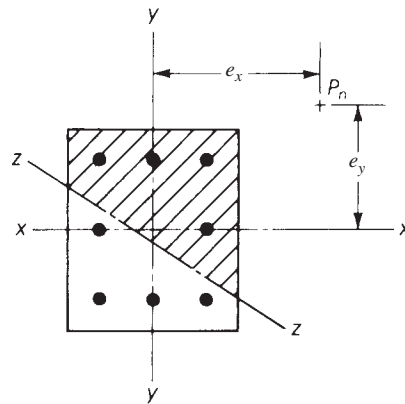


**Figure 11.24** Uniaxial bending with load  $P_n$  along the  $x$ -axis, with eccentricity  $e_x$ .

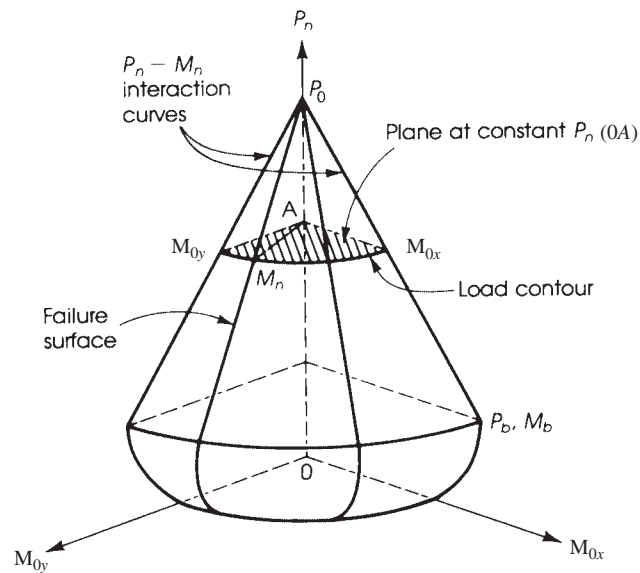
acting along the  $x$ -axis (Fig. 11.24) with an eccentricity  $e_x$ , causing a combination of an axial load  $P_n$  and a moment  $M_{ny} = P_n e_x$ .

If the load  $P_n$  is acting anywhere such that its distance from the  $x$ -axis is  $e_y$  and its distance from the  $y$ -axis is  $e_x$ , then the column section will be subjected to a combination of forces: An axial load  $P_n$ , a moment about the  $x$ -axis  $= M_{nx} = P_n e_y$  and a moment about the  $y$ -axis  $= M_{ny} = P_n e_x$  (Fig. 11.25). The column section in this case is said to be subjected to *biaxial bending*. The analysis and design of columns under this combination of forces is not simple when the principles of statics are used. The neutral axis is at an angle with respect to both axes, and lengthy calculations are needed to determine the location of the neutral axis, strains, concrete compression area, and internal forces and their point of application. Therefore, it was necessary to develop practical solutions to estimate the strength of columns under axial load and biaxial bending. The formulas developed relate the response of the column in biaxial bending to its uniaxial strength about each major axis.

The biaxial bending strength of an axially loaded column can be represented by a three-dimensional interaction curve, as shown in Fig. 11.26. The surface is formed by a series of uniaxial interaction curves drawn radially from the  $P_n$  axis. The curve  $M_{0x}$  represents the



**Figure 11.25** Biaxial bending.



**Figure 11.26** Biaxial interaction surface.

interaction curve in uniaxial bending about the  $x$ -axis, and the curve  $M_{0y}$  represents the curve in uniaxial bending about the  $y$ -axis. The plane at constant axial load  $P_n$  shown in Fig. 11.26 represents the contour of the bending moment  $M_n$  about any axis.

Different shapes of columns may be used to resist axial loads and biaxial bending. Circular, square, or rectangular column cross sections may be used with equal or unequal bending capacities in the  $x$  and  $y$  directions.

### 11.15 CIRCULAR COLUMNS WITH UNIFORM REINFORCEMENT UNDER BIAxIAL BENDING

Circular columns with reinforcement distributed uniformly about the perimeter of the section have almost the same moment capacity in all directions. If a circular column is subjected to biaxial

bending about the  $x$  and  $y$  axes, the equivalent uniaxial  $M_u$  moment can be calculated using the following equations:

$$M_u = \sqrt{(M_{ux})^2 + (M_{uy})^2} = P_u e \quad (11.29)$$

and

$$e = \sqrt{(e_x)^2 + (e_y)^2} = \frac{M_u}{P_u} \quad (11.30)$$

where

$M_{ux} = P_u e_y$  = factored moment about the  $x$ -axis

$M_{uy} = P_u e_x$  = factored moment about the  $y$ -axis

$M_u = P_u e$  = equivalent uniaxial factored moment of the section due to  $M_{ux}$  and  $M_{uy}$

In circular columns, a minimum of six bars should be used, and these should be uniformly distributed in the section.

### Example 11.17 Circular Column

Determine the load capacity  $P_n$  of a 20-in.-diameter column reinforced with 10 no. 10 bars when  $e_x = 4$  in. and  $e_y = 6$  in. Use  $f'_c = 4$  ksi and  $f_y = 60$  ksi.

#### Solution

1. Calculate the eccentricity that is equivalent to uniaxial loading by using Eq. 11.30.

$$e(\text{for uniaxial loading}) = \sqrt{e_x^2 + e_y^2} = \sqrt{(4)^2 + (6)^2} = 7.211 \text{ in.}$$

2. Determine the load capacity of the column based on  $e = 7.211$  in. Proceed as in Example 11.9:

$$d = 17.12 \text{ in.} \quad a = 9.81 \text{ in.} \quad c = 11.54 \text{ in. (by trial)}$$

$$C_c = 521.2 \text{ K} \quad \Sigma C_s = 269.8 \text{ K} \quad \Sigma T = 132.1 \text{ K}$$

$$P_n = C_c + \Sigma C_s - \Sigma T = 650 \text{ K}$$

3. For a balanced condition,

$$c_b = \left( \frac{87}{87 + f_y} \right) d_t = \left( \frac{87}{147} \right) 17.12 = 10.13 \text{ in.}$$

$$c = 11.54 \text{ in.} > c_b$$

which is a compression failure case.

### Example 11.18 Circular Column

Design a 16-in. circular column subject to biaxial bending using the equivalent uniaxial moment method. Given  $P_u = 200$  K,  $M_{ux} = 1000$  K · in,  $M_{uy} = 700$  K · in,  $f'_c = 4$  ksi,  $f_y = 60$  ksi.

#### Solution

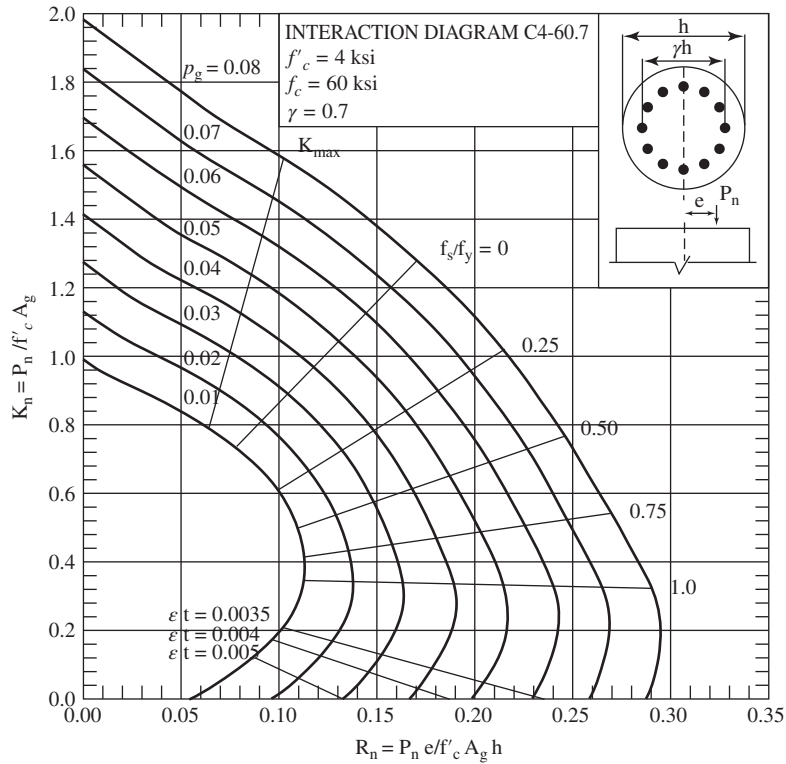
1. Determine nominal load:

For spiral column  $\phi = 0.75$

Nominal load =  $200/0.75 = 266.67$  K

Nominal moment capacity about  $x$  axis  $M_{nx} = 1000/0.75 = 1333.33$  K · in.

Nominal moment capacity about  $y$  axis  $M_{ny} = 700/0.75 = 933.33$  K · in.



**Figure 11.27** Example 11.18. Courtesy of American Concrete Institute [7].

2. Determine the equivalent moment  $M_{nr}$  using Eq. 11.29:

$$M_{nr} = \sqrt{M_{nx}^2 + M_{ny}^2} = \sqrt{1333^2 + 933^2} = 1627.54 \text{ K} \cdot \text{in.}$$

3. Calculate  $\rho_g$  using interaction diagram (Fig. 11.27):

Compute  $A_g$ :

$$A_g = \frac{\pi D^2}{4} = \frac{3.14 \times 16^2}{4} = 200.96 \text{ in.}^2$$

$$\text{Compute } k_n = \frac{P_n}{f'_c A_g} = \frac{266.67}{4 \times 200.96} = 0.33$$

$$\text{Compute } R_n = \frac{M_n}{f'_c A_g h} = \frac{1627.54}{4 \times 200.96 \times 15} = 0.13$$

$$\text{Compute } \gamma = \frac{h - 5}{h} = \frac{16 - 5}{16} = 0.69$$

From the interaction diagram (Fig. 11.27) for  $\gamma = 0.7$ ,  $\rho_g = 0.05$

$$A_{st} = 0.05 \times 200.96 = 10.05 \text{ in.}^2$$

Provide 8 no. 10 bars,  $A_{st} = 10.16 \text{ in.}^2$

4. Check minimum load capacity of the column from Eq. 10.7:

$$\begin{aligned}\phi P_{nmx} &= 0.85\phi(0.85f'_c(A_g - A_{st}) + f_y A_{st}) \quad (\text{ACI Eq. 10.1}) \\ &= 0.85(0.75)(0.85)(4)(200.96 - 10.16) + (60)(10.16) \\ &= 1023.2 \text{ K} > 200 \text{ K, the section is adequate}\end{aligned}$$

## 11.16 SQUARE AND RECTANGULAR COLUMNS UNDER BIAXIAL BENDING

### 11.16.1 Bresler Reciprocal Method

Square or rectangular columns with unequal bending moments about their major axes will require a different amount of reinforcement in each direction. An approximate method of analysis of such sections was developed by Boris Bresler and is called the Bresler reciprocal method [9, 12]. According to this method, the load capacity of the column under biaxial bending can be determined by using the following expression:

$$\frac{1}{P_u} = \frac{1}{P_{ux}} + \frac{1}{P_{uy}} - \frac{1}{P_{u_0}} \quad (11.31)$$

or

$$\frac{1}{P_n} = \frac{1}{P_{nx}} + \frac{1}{P_{ny}} - \frac{1}{P_{n_0}} \quad (11.32)$$

where

- $P_u$  = factored load under biaxial bending
- $P_{ux}$  = factored uniaxial load when the load acts at eccentricity  $e_y$  and  $e_x = 0$
- $P_{uy}$  = factored uniaxial load when the load acts at an eccentricity  $e_x$  and  $e_y = 0$
- $P_{u_0}$  = factored axial load when  $e_x = e_y = 0$

$$P_n = \frac{P_u}{\phi} \quad P_{nx} = \frac{P_{ux}}{\phi} \quad P_{ny} = \frac{P_{uy}}{\phi} \quad P_{n_0} = \frac{P_{u_0}}{\phi}$$

The uniaxial load strengths  $P_{nx}$ ,  $P_{ny}$ , and  $P_{n_0}$  can be calculated according to the equations and method given earlier in this chapter. After that, they are substituted into Eq. 11.32 to calculate  $P_n$ .

The Bresler equation is valid for all cases when  $P_n$  is equal to or greater than  $0.10P_{n_0}$ . When  $P_n$  is less than  $0.10P_{n_0}$ , the axial force may be neglected and the section can be designed as a member subjected to pure biaxial bending according to the following equations:

$$\frac{M_{ux}}{M_x} + \frac{M_{uy}}{M_y} \leq 1.0 \quad (11.33)$$

or

$$\frac{M_{nx}}{M_{0x}} + \frac{M_{ny}}{M_{0y}} \leq 1.0 \quad (11.34)$$

where

- $M_{ux} = P_u e_y$  = design moment about  $x$ -axis
- $M_{uy} = P_u e_x$  = design moment about the  $y$ -axis
- $M_x$  and  $M_y$  = uniaxial moment strengths about the  $x$  and  $y$  axes

$$M_{nx} = \frac{M_{ux}}{\phi} \quad M_{ny} = \frac{M_{uy}}{\phi} \quad M_{0x} = \frac{M_x}{\phi} \quad M_{0y} = \frac{M_y}{\phi}$$

The Bresler equation is not recommended when the section is subjected to axial tension loads.

### 11.16.2 Bresler Load Contour Method

In this method, the failure surface shown in Fig. 11.26 is cut at a constant value of  $P_n$ , giving the related values of  $M_{nx}$  and  $M_{ny}$ . The general nondimension expression for the load contour method is

$$\left(\frac{M_{nx}}{M_{0x}}\right)^{\alpha_1} + \left(\frac{M_{ny}}{M_{0y}}\right)^{\alpha_2} = 1.0 \quad (11.35)$$

Bresler indicated that the exponent  $\alpha$  can have the same value in both terms of this expression ( $\alpha_1 = \alpha_2$ ). Furthermore, he indicated that the value of  $\alpha$  varies between 1.15 and 1.55 and can be assumed to be 1.5 for rectangular sections. For square sections,  $\alpha$  varies between 1.5 and 2.0, and an average value of  $\alpha = 1.75$  may be used for practical designs. When the reinforcement is uniformly distributed around the four faces in square columns,  $\alpha$  may be assumed to be 1.5:

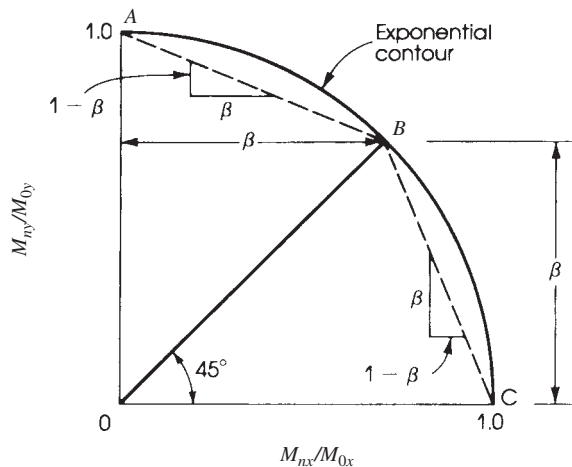
$$\left(\frac{M_{nx}}{M_{0x}}\right)^{1.5} + \left(\frac{M_{ny}}{M_{0y}}\right)^{1.5} = 1.0 \quad (11.36)$$

The British Code assumed  $\alpha = 1.0, 1.33, 1.67,$  and  $2.0$  when the ratio  $P_u/1.1P_{u0}$  is equal to  $0.2, 0.4, 0.6,$  and  $\geq 0.8$ , respectively.

## 11.17 PARME LOAD CONTOUR METHOD

The load contour approach, proposed by the PCA, is an extension of the method developed by Bresler. In this approach, which is also called the *Parme method* [11], a point  $B$  on the load contour (of a horizontal plane at a constant  $P_n$  shown in Fig. 11.28) is defined such that the biaxial moment capacities  $M_{nx}$  and  $M_{ny}$  are in the same ratio as the uniaxial moment capacities  $M_{0x}$  and  $M_{0y}$ ; that is,

$$\frac{M_{nx}}{M_{ny}} = \frac{M_{0x}}{M_{0y}} \quad \text{or} \quad \frac{M_{nx}}{M_{0x}} = \frac{M_{ny}}{M_{0y}} = \beta$$



**Figure 11.28** Nondimensional load contour at constant  $P_n$  (straight-line approximation).

The ratio  $\beta$  is shown in Fig. 11.28 and represents that constant portion of the uniaxial moment capacities that may be permitted to act simultaneously on the column section.

For practical design, the load contour shown in Fig. 11.28 may be approximated by two straight lines,  $AB$  and  $BC$ . The slope of line  $AB$  is  $(1 - \beta)/\beta$ , and the slope of line  $BC$  is  $\beta/(1 - \beta)$ . Therefore, when

$$\frac{M_{ny}}{M_{0y}} > \frac{M_{nx}}{M_{0x}}$$

then

$$\frac{M_{ny}}{M_{0y}} + \frac{M_{nx}}{M_{0x}} \left( \frac{1 - \beta}{\beta} \right) = 1 \quad (11.37)$$

and when

$$\frac{M_{ny}}{M_{0y}} < \frac{M_{nx}}{M_{0x}}$$

then

$$\frac{M_{nx}}{M_{0x}} + \frac{M_{ny}}{M_{0y}} \left( \frac{1 - \beta}{\beta} \right) = 1 \quad (11.38)$$

The actual value of  $\beta$  depends on the ratio  $P_n/P_0$  as well as the material and properties of the cross section. For lightly loaded columns,  $\beta$  will vary from 0.55 to 0.7. An average value of  $\beta = 0.65$  can be used for design purposes.

When uniformly distributed reinforcement is adopted along all faces of rectangular columns, the ratio  $M_{0y}/M_{0x}$  is approximately  $b/h$ , where  $b$  and  $h$  are the width and total depth of the rectangular section, respectively. Substituting this ratio in Eqs. 11.37 and Eqs. 11.38,

$$M_{ny} + M_{nx} \left( \frac{b}{h} \right) \left( \frac{1 - \beta}{\beta} \right) \approx M_{0y} \quad (11.39)$$

and

$$M_{nx} + M_{ny} \left( \frac{h}{b} \right) \left( \frac{1 - \beta}{\beta} \right) \approx M_{0x} \quad (11.40)$$

For  $\beta = 0.65$  and  $h/b = 1.5$ ,

$$M_{0y} \approx M_{ny} + 0.36M_{nx} \quad (11.41)$$

and

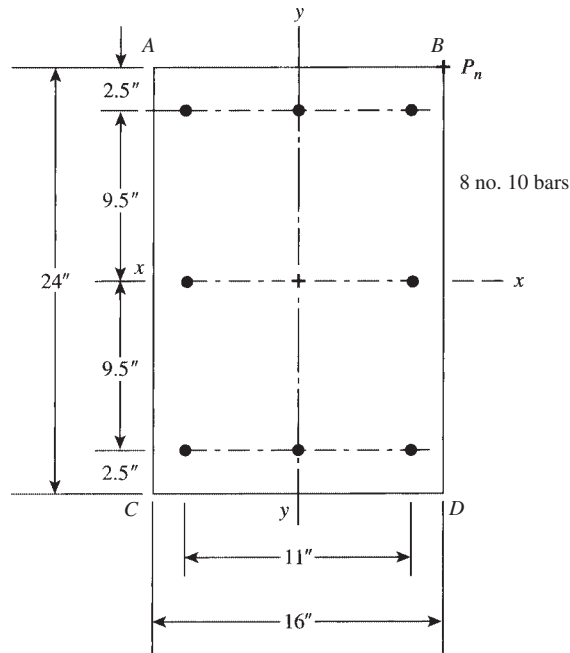
$$M_{0x} \approx M_{nx} + 0.80M_{ny} \quad (11.42)$$

From this presentation, it can be seen that direct explicit equations for the design of columns under axial load and biaxial bending are not available. Therefore, the designer should have enough experience to make an initial estimate of the section using the values of  $P_n$ ,  $M_{nx}$ , and  $M_{ny}$  and the uniaxial equations and then check the adequacy of the column section using the equations for biaxial bending or by computer.

### Example 11.19

The section of a short tied column is  $16 \times 24$  in. and is reinforced with eight no. 10 bars distributed as shown in Fig. 11.29. Determine the design load on the section  $\phi P_n$  if it acts at  $e_x = 8$  in. and  $e_y = 12$  in. Use  $f'_c = 5$  ksi,  $f_y = 60$  ksi, and the Bresler reciprocal equation.





**Figure 11.29** Example 11.19: Biaxial load, Bresler method:  $P_n = 421.5 \text{ K}$ .

### Solution

1. Determine the uniaxial load capacity  $P_{nx}$  about the  $x$ -axis when  $e_y = 12 \text{ in.}$  In this case,  $b = 16 \text{ in.}$ ,  $h = 24 \text{ in.}$ ,  $d = 21.5 \text{ in.}$ ,  $d' = 2.5 \text{ in.}$ , and  $A_s = A'_s = 3.81 \text{ in.}^2$ . The solution will be performed using statics following the steps of Examples 11.2 and 11.4 for balanced and compression-control conditions.

- a. For the balanced condition,

$$c_b = \left( \frac{87}{87 + f_y} \right) d = \left( \frac{87}{147} \right) 21.5 = 12.72 \text{ in.}$$

$$a_b = 0.80(12.72) = 10.18 \text{ in.} \quad (\beta_1 = 0.8 \text{ when } f'_c = 5 \text{ ksi})$$

$$C_c = 0.85f'_c ab = 692.3 \text{ K} \quad f'_s = 87 \left( \frac{c - d'}{c} \right) = 69.9 \text{ ksi}$$

Then  $f'_s = 60 \text{ ksi}$ .

$$C_s = A'_s(f_y - 0.85f'_c) = 212.4 \text{ K} \quad T = A_s f_y = 228.6 \text{ K}$$

$$P_{0x} = C_c + C_s - T = 676.1 \text{ K}$$

$$\phi P_{bx} = 0.65 P_{0x} = 439.5 \text{ K} \quad (\phi = 0.65 \text{ for } \epsilon_t = 0.002)$$

- b. For  $e_y = 12 \text{ in.}$ ,  $< d = 21.5 \text{ in.}$ , assume compression failure and follow the steps of Example 11.4 to get  $a = 10.65 \text{ in.}$  and  $c = a/0.8 = 13.31 \text{ in.}$   $> c_b = 12.72 \text{ in.}$  Thus, compression controls. Check

$$f'_s = 87 \left( \frac{c - d'}{c} \right) = 70 \text{ ksi} > f_y$$

Therefore,  $f'_s = 60$  ksi. Check

$$f_s = 87 \left( \frac{d-c}{c} \right) = 53.53 \text{ ksi} > 60 \text{ ksi}$$

Calculate forces:  $C_c = 0.85f'_c ab = 724.2$  K,  $C_s = A'_s(f'_y - 0.85f'_c) = 212.4$  K,  $T = A_s f'_s = 203.95$  K,  $P_{nx} = C_c + C_s - T = 732.6$  K.  $P_{nx} > P_{bx}$ , so this is a compression failure case as assumed.

$$\epsilon_t = \left( \frac{d-c}{c} \right) 0.003 = 0.00185$$

$$\epsilon_t < 0.002 \quad \phi = 0.65$$

$$P_{ux} = \phi P_{nx} = 476.2 \text{ K}$$

- c. Take moments about  $A_s$  using Eq. 11.11,

$$d'' = 9.5 \text{ in.} \quad e' = 21.5 \text{ in.}$$

$$P_{nx} = \frac{1}{e'} \left[ C_c \left( d - \frac{a}{2} \right) + C_s (d - d') \right] = 732.6 \text{ K}$$

2. Determine the uniaxial load capacity  $P_{ny}$  about the y-axis when  $e_x = 8$  in. In this case,  $b = 24$  in.,  $h = 16$  in.,  $d = 13.5$  in.,  $d' = 2.5$  in., and  $A_s = A'_s = 3.81$  in.<sup>2</sup> The solution will be performed using statics, as explained in step 1.

- a. Balanced condition:

$$c_b = \left( \frac{87}{87 + f'_y} \right) d = \left( \frac{87}{147} \right) 13.5 = 7.99 \text{ in.} \quad a_b = 0.8(7.99) = 6.39 \text{ in.}$$

$$C_c = 0.85f'_c ab = 651.8 \text{ K} \quad f'_s = 87 \left( \frac{c-d'}{c} \right) = 59.8 \text{ ksi}$$

$$C_s = A'_s(f'_s - 0.85f'_c) = 211.6 \text{ K} \quad T = A_s f'_y = 228.6 \text{ K}$$

In a balanced load,  $P_{by} = C_c + C_s - T = 634.8$  K,  $\phi P_{by} = 0.65$ , and  $P_{by} = 444.4$  K.

- b. For  $e_x = 8$  in., assume compression failure case and follow the steps of Example 11.4 to get  $a = 6.65$  in. and  $c = a/0.8 = 8.31$  in.  $> c_b$  (compression failure). Check

$$f'_s = 87 \left( \frac{c-d'}{c} \right) = 60.8 \text{ ksi}$$

Therefore,  $f'_s = 60$  ksi. Check

$$f_s = 87 \left( \frac{d-c}{c} \right) = 54.3 \text{ ksi}$$

Calculate forces:  $C_c = 0.85f'_c ab = 678.3$  K,  $C_s = A'_s(60 - 0.85f'_c) = 212.4$  K,  $T = A_s f'_s = 206.9$  K,  $P_{ny} = C_c + C_s - T = 683.3$  K, and  $\phi P_{ny} = P_{uy} = 0.65 P_{ny} = 444.5$  K. Because  $P_{ny} > P_{by}$ , compression failure occurs, as assumed:

$$\epsilon_t = \left( \frac{d-c}{c} \right) 0.003 = 0.00187$$

$$\epsilon_t < 0.002 \quad \phi = 0.65$$

$$P_{uy} = \phi P_{ny} = 444.5 \text{ K}$$

c. Take moments about  $A_s$  using Eq. 11.11:

$$d'' = 5.5 \text{ in.} \quad e' = 13.5 \text{ in.}$$

$$P_{ny} = \frac{1}{e'} \left[ C_c \left( d - \frac{a}{2} \right) + C_s (d - d') \right] = 683.8 \text{ K}$$

3. Determine the theoretical axial load  $P_{n0}$ :

$$\begin{aligned} P_{n0} &= 0.85f'_c A_g + A_{st}(f_y - 0.85f'_c) \\ &= 0.85(5)(16 \times 24) + 10.16(60 - 0.85 \times 5) = 2198.4 \text{ K} \quad \phi P_{n0} = 0.65P_{n0} = 1429 \text{ K} \end{aligned}$$

4. Using the Bresler equation (Eq. 11.31), multiply by 100:

$$\frac{100}{P_u} = \frac{100}{476.2} + \frac{100}{444.5} - \frac{100}{1429} = 0.365$$

$$P_u = 274 \text{ K} \quad \text{and} \quad P_n = \frac{P_u}{0.65} = 421.5 \text{ K}$$

### Notes

1. Approximate equations or the ACI charts may be used to calculate  $P_{nx}$  and  $P_{ny}$ . However, since the Bresler equation is an approximate solution, it is preferable to use accurate procedures, as was done in this example, to calculate  $P_{nx}$  and  $P_{ny}$ . Many approximations in the solution will produce inaccurate results. Computer programs based on statics are available and may be used with proper checking of the output.
2. In Example 11.19, the areas of the corner bars were used twice, once to calculate  $P_{nx}$  and once to calculate  $P_{ny}$ . The results obtained are consistent with similar solutions. A conservative solution is to use half of the corner bars in each direction, giving  $A_s = A'_s = 2(1.27) = 2.54 \text{ in.}^2$ , which will reduce the values of  $P_{nx}$  and  $P_{ny}$ .

### Example 11.20

Determine the nominal design load,  $P_n$ , for the column section of the previous example using the Parme load contour method; see Fig. 11.30.

### Solution

1. Assume  $\beta = 0.65$ . The uniaxial load capacities in the direction of  $x$  and  $y$  axes were calculated in Example 11.19:

$$P_{ux} = 476.2 \text{ K} \quad P_{uy} = 444.5 \text{ K} \quad P_{nx} = 732.6 \text{ K} \quad P_{ny} = 683.8 \text{ K}$$

2. The moment capacity of the section about the  $x$ -axis is

$$M_{0x} = P_{nx}e_y = 732.6 \times 12$$

The moment capacity of the section about the  $y$ -axis is

$$M_{0y} = P_{ny}e_x = 683.8 \times 8 \text{ K} \cdot \text{in}$$

3. Let the nominal load capacity be  $P_n$ . The nominal design moment on the section about the  $x$ -axis is

$$M_{nx} = P_n e_y = P_n \times 12 \text{ K} \cdot \text{in.}$$

and that about the  $y$ -axis is

$$M_{ny} = P_n e_x = 8P_n$$

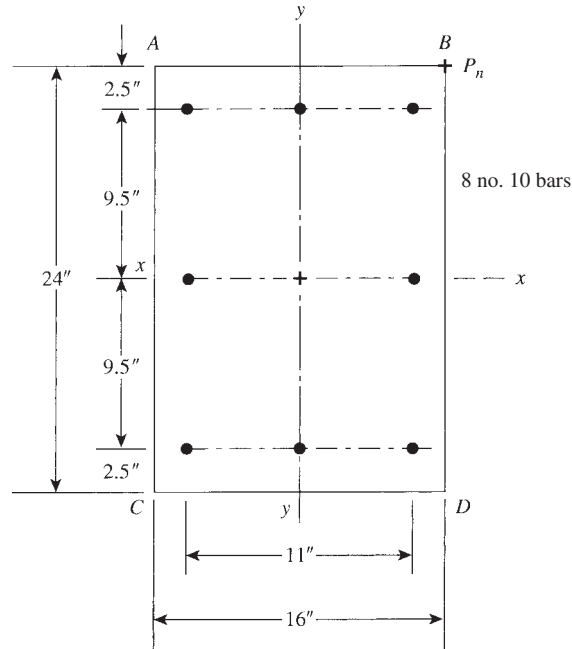


Figure 11.30 Example 11.20: Biaxial load, PCA method:  $P_n = 455$  K.

4. Check if  $M_{ny}/M_{0y} > M_{nx}/M_{0x}$ :

$$\frac{8P_n}{683.8 \times 8} > \frac{12P_n}{732.6 \times 12} \quad \text{or} \quad 1.463 \times 10^{-3} P_n > 1.365 \times 10^{-3} P_n$$

Then  $M_{ny}/M_{0y} > M_{nx}/M_{0x}$ . Therefore, use Eq. 11.34.

5. 
$$\frac{8P_n}{683.8 \times 8} + \frac{12P_n}{732.6 \times 12} \left( \frac{1 - 0.65}{0.65} \right) = 1$$

Multiply by 1000 to simplify calculations.

$$1.463P_n + 0.735P_n = 1000$$

$$P_n = 455 \text{ K} \quad P_u = \phi P_n = 295.75 \text{ K} \quad (\phi = 0.65)$$

Note that  $P_u$  is greater than the value of 274 K obtained by the Bresler reciprocal method (Eq. 11.31) in the previous example by about 8%.

## 11.18 EQUATION OF FAILURE SURFACE

A general equation for the analysis and design of reinforced concrete short and tied rectangular columns was suggested by Hsu [16]. The equation is supposed to represent the failure surface and interaction diagrams of columns subjected to combined biaxial bending and axial load, as shown

in Fig. 11.26. The axial load can be compressive or a tensile force. The equation is presented as follows:

$$\left(\frac{P_n - P_b}{P_0 - P_b}\right) + \left(\frac{M_{nx}}{M_{bx}}\right)^{1.5} + \left(\frac{M_{ny}}{M_{by}}\right)^{1.5} = 1.0 \quad (11.43)$$

where

- $P_n$  = nominal axial strength (positive if compression and negative if tension) for given eccentricity
- $P_0$  = nominal axial load (positive if compression and negative if tension) at zero eccentricity
- $P_b$  = nominal axial compressive load at balanced strain condition
- $M_{nx}, M_{ny}$  = nominal bending moments about  $x$  and  $y$  axes, respectively
- $M_{bx}, M_{by}$  = nominal balanced bending moments about  $x$  and  $y$  axes, respectively, at balanced strain conditions

To use Eq. 11.4, all terms must have a positive sign. The value of  $P_0$  was given earlier (Eq. 10.1):

$$P_0 = 0.85f'_c(A_g - A_{st}) + A_{st}f_y \quad (11.44)$$

The nominal balanced load,  $P_b$ , and the nominal balanced moment,  $M_b = P_b e_b$ , were given in Eqs. 11.6 and Eqs. 11.7, respectively, for sections with tension and compression reinforcement only. For other sections, these values can be obtained by using the principles of statics.

Note that the equation of failure surface can also be used for uniaxial bending representing the interaction diagram. In this case, the third term will be omitted when  $e_x = 0$ , and the second term will be omitted when  $e_y = 0$ .

When  $e_x = 0$  (moment about the  $x$ -axis only),

$$\left(\frac{P_n - P_b}{P_0 - P_b}\right) + \left(\frac{M_{nx}}{M_{bx}}\right)^{1.5} = 1.0 \quad (11.45)$$

(This is Eq. 11.21, given earlier.) When  $e_y = 0$  (moment about the  $y$  axis only),

$$\left(\frac{P_n - P_b}{P_0 - P_b}\right) + \left(\frac{M_{ny}}{M_{by}}\right)^{1.5} = 1.0 \quad (11.46)$$

Applying Eq. 11.4 to 11.2 and 11.4,  $P_b = 453.4$  K,  $M_{bx} = 6810.8$  K.in.,  $e_y = 10$  in., and  $P_0 = 0.85(4)(14 \times 22 - 8) + 8(60) = 1500$  K.

$$\frac{P_n - 453.4}{1500 - 453.4} + \left(\frac{10P_n}{6810.8}\right)^{1.5} = 1.0$$

Multiply by 1000 and solve for  $P_n$ :

$$(0.9555P_n - 433.2) + 0.05626P_n^{1.5} = 1000$$

$$0.9555P_n + 0.05626P_n^{1.5} = 1433.2$$

Let  $P_n = 611$  K, which is close to that obtained by analysis.

**Example 11.21**

Determine the nominal design load,  $P_n$ , for the column section of Example 11.19 using the equation of failure surface.

**Solution**

1. Compute

$$\begin{aligned} P_0 &= 0.85f'_c(A_g - A_{st}) + A_{st}f_y \\ &= 0.85(5)(16 \times 24 - 10.16) + (10.16 \times 60) \\ &= 2198.4 \text{ K} \end{aligned}$$

2. Compute  $P_b$  and  $M_b$  using Eqs. 11.6 and Eqs. 11.8 about the  $x$  and  $y$  axes, respectively.

- a. About the  $x$ -axis,

$$a_{bx} = \frac{87d_t}{87 + f_y} = \frac{87(21.5)}{87 + 60} = 12.72 \text{ in.}$$

$$a_{bx} = 0.8(12.72) = 10.18 \text{ in.}$$

$$f'_s = 87 \left( \frac{c - d'}{c} \right) = 69.9 \text{ ksi} \quad f'_s = 60 \text{ ksi}$$

$$d''_x = 9.5 \text{ in.} \quad A_s = A'_s = 3.81 \text{ in.}^2$$

$$\begin{aligned} P_{bx} &= 0.85f'_c a_x b + A'_s(f_y - 0.85f'_c) - A_s f_y \\ &= 0.85(5)(10.18)(16) + 3.81(60 - 0.85 \times 5) - 3.81(60) \\ &= 676.1 \text{ K} \end{aligned}$$

$$\begin{aligned} M_{bx} &= 0.85(5)(10.18)(16) \left( 21.5 - \frac{10.18}{2} - 9.5 \right) \\ &\quad + 3.81(60 - 0.85 \times 5) \times (21.5 - 2.5 - 9.5) + 3.81(60)(9.5) \\ &= 8973 \text{ K} \cdot \text{in.} = 747.8 \text{ K} \cdot \text{ft} \end{aligned}$$

- b. About the  $y$ -axis:  $d_t = 13.5 \text{ in.}$ ,  $d''_y = 5.5 \text{ in.}$ ,  $A_s = A'_s = 3.81 \text{ in.}^2$

$$c_{by} = \frac{87(13.5)}{87 + 60} = 7.99 \text{ in.}$$

$$a_{by} = 0.8(7.99) = 6.39 \text{ in.} \quad f'_s = 87 \left( \frac{c - d'}{c} \right) = 59.8 \text{ ksi}$$

$$\begin{aligned} P_{by} &= 0.85(5)(6.39)(24) + 3.81(59.8 - 0.85 \times 5) - 3.81(60) \\ &= 634.8 \text{ K} \end{aligned}$$

$$\begin{aligned} M_{by} &= 0.85(5)(6.39)(24) \left( 13.5 - \frac{6.39}{2} - 5.5 \right) \\ &\quad + 3.81(59.8 - 0.85 \times 5)(13.5 - 2.5 - 5.5) + 3.81(60)(5.5) \\ &= 5557.3 \text{ K} \cdot \text{in.} = 463 \text{ K} \cdot \text{ft} \end{aligned}$$

3. Compute the nominal balanced load for biaxial bending,  $P_{bb}$ :

$$\tan \alpha = \frac{M_{ny}}{M_{nx}} = \frac{P_n e_x}{P_n e_y} = \frac{e_x}{e_y} = \frac{8}{12} \quad \alpha = 33.7^\circ$$

$$\frac{P_{bx} - P_{by}}{90^\circ} = \frac{\Delta P_b}{90^\circ - \alpha^\circ} \quad \text{or} \quad \frac{676.1 - 634.8}{90} = \frac{\Delta P_b}{90 - 33.7}$$

$$\Delta P_b = 25.8 \text{ K}$$

$$P_{bb} = P_{by} + \Delta P_b = 634.8 + 25.8 = 660.6 \text{ K}$$

4. Compute  $P_n$  from the equation of failure surface:

$$\frac{P_n - 660.6}{2198.4 - 660.6} + \left( \frac{P_n \times 12}{8973} \right)^{1.5} + \left( \frac{P_n \times 8}{5557.3} \right)^{1.5} = 1.0$$

Multiply by 1000 and solve for  $P_n$ :

$$(0.65P_n - 429.85) + 0.0489P_n^{1.5} + 0.0546P_n^{1.5} = 1000$$

$$0.65P_n + 0.1035P_n^{1.5} = 1429.85$$

By trial,  $P_n = 487 \text{ K}$ . Because  $P_n < P_{bb}$ , it is a tension failure case for biaxial bending, and thus  $P_0 = -2198.4 \text{ K}$  (to keep the first term positive).

$$1000 \left( \frac{P_n - 660.9}{-2198.4 - 660.9} \right) + 0.0489P_n^{1.5} + 0.0546P_n^{1.5} = 1000$$

$$0.35P_n + 0.1035P_n^{1.5} = 769.1$$

$$P_n = 429 \text{ K} \quad \text{and} \quad P_u = 0.65P_n = 278.8 \text{ K}$$

*Note:* The strength capacity,  $\phi P_n$ , of the same rectangular section was calculated using the Bresler reciprocal equation (Example 11.19), Parme method (Example 11.20), and Hsu method (Example 11.21) to get  $\phi P_n = 421.5$ , 455, and 429 K, respectively. The Parme method gave the highest value for this example.

## 11.19 SI EXAMPLE

### Example 11.22

Determine the balanced compressive forces  $P_b$ ,  $e_b$ , and  $M_b$  for the section shown in Fig. 11.31. Use  $f'_c = 30 \text{ MPa}$  and  $f_y = 400 \text{ MPa}$  ( $b = 350 \text{ mm}$ ,  $d = 490 \text{ mm}$ ).

#### Solution

1. For a balanced condition, the strain in the concrete is 0.003 and the strain in the tension steel is  $\epsilon_y = f_y/E_s = 400/200,000 = 0.002$ , where  $E_s = 200,000 \text{ MPa}$ .

$$A_s = A'_s = 4(700) = 2800 \text{ mm}^2$$

2. Locate the neutral axis depth,  $c_b$ :

$$c_b = \left( \frac{600}{600 + f_y} \right) d_t \quad (\text{where } f_y \text{ is in MPa})$$

$$= \left( \frac{600}{600 + 420} \right) (490) = 288 \text{ mm}$$

$$a_b = 0.85c_b = 0.85 \times 288 = 245 \text{ mm}$$

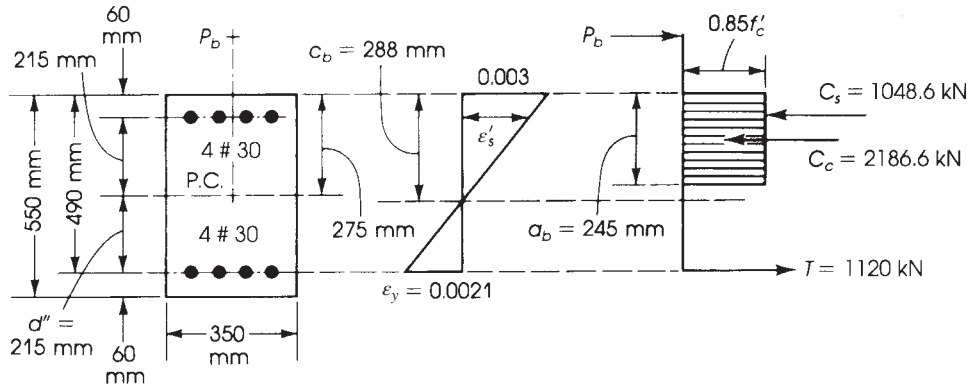


Figure 11.31 Example 11.22.

3. Check if compression steel yields. From the strain diagram,

$$\frac{\epsilon'_s}{0.003} = \frac{c - d'}{c} = \frac{288 - 60}{288}$$

$$\epsilon'_s = 0.00238 > \epsilon_y$$

Therefore, compression steel yields.

4. Calculate the forces acting on the section:

$$C_c = 0.85f'_c ab = \frac{0.85}{1000} \times 30 \times 245 \times 350 = 2186.6 \text{ kN}$$

$$T = A_s f_y = 2800 \times 0.400 \times 1120 \text{ kN}$$

$$C_s = A'_s (f_y - 0.85f'_c) = \frac{2800 \text{ mm}^2}{1000} (400 - 0.85 \times 30) = 1048.6 \text{ kN}$$

5. Calculate  $P_b$  and  $M_b$ :

$$P_b = C_c + C_s - T = 2115.2 \text{ kN}$$

From Eq. 11.10,

$$M_b = P_b e_b = C_c \left( d - \frac{a}{1} - d'' \right) + C_s (d - d' - d'') + T d''$$

The plastic centroid is at the centroid of the section and  $d'' = 215 \text{ mm}$ .

$$M_b = 2186.6 \left( 490 - \frac{245}{2} - 215 \right) + 1048.6 (490 - 60 - 215)$$

$$+ 1120 \times 215 = 799.7 \text{ kN} \cdot \text{m}$$

$$e_b = \frac{M_b}{P_b} = \frac{799.7}{2115.2} = 0.378 \text{ m} = 378 \text{ mm}$$



**SUMMARY****Sections 11.1–11.3**

1. The plastic centroid can be obtained by determining the location of the resultant force produced by the steel and the concrete, assuming both are stressed in compression to  $f_y$  and  $0.85f'_c$ , respectively.
2. On a load–moment interaction diagram the following cases of analysis are developed:
  - a. Axial compression,  $P_0$
  - b. Maximum nominal axial load,  $P_{n, \max} = 0.8P_0$  (for tied columns) and  $P_{n, \max} = 0.85P_0$  (for spiral columns)
  - c. Compression failure occurs when  $P_n > P_b$  or  $e < e_b$
  - d. Balanced condition,  $P_b$  and  $M_b$
  - e. Tension failure occurs when  $P_n < P_b$  or  $e > e_b$
  - f. Pure flexure

**Section 11.4**

1. For compression-controlled sections,  $\phi = 0.65$ , while for tension-controlled section,  $\phi = 0.9$ .
2. For the transition region,

$$\phi = \begin{cases} 0.65 + (\epsilon_t - 0.002) \left( \frac{250}{3} \right) & \text{for tied columns} \\ 0.75 + (\epsilon_t - 0.002)(50) & \text{for spiral columns} \end{cases}$$

**Section 11.5**

For a balanced section,

$$c_b = \frac{87d_t}{87 + f_y} \quad \text{and} \quad a_b = \beta_1 c_b$$

$$\beta_1 = 0.85 \quad \text{for } f'_c \leq 4 \text{ ksi}$$

$$P_b = C_c + C_s - T = 0.85f'_c ab + A'_s(f_y - 0.85f'_c) - A_s f_y$$

$$M_b = P_b e_b = C_c \left( d - \frac{a}{2} - d'' \right) + T d'' + C_s (d - d' - d'')$$

$$e_b = \frac{M_b}{P_b}$$

**Section 11.6**

The equations for the general analysis of rectangular sections under eccentric forces are summarized.

**Sections 11.7 and 11.8**

Examples for the cases when tension and compression controls are given.

**Sections 11.9 and 11.10**

Examples are given for the interaction diagram and for the case when side bars are used.

**Section 11.11**

This section gives the load capacity of circular columns. The cases of a balanced section when compression controls are explained by examples.

**Section 11.12**

This section gives examples of the analysis and design of columns using charts.

**Section 11.13**

This section gives examples of the design of column sections.

**Sections 11.14 and 11.18**

Biaxial bending:

1. For circular columns with uniform reinforcement,

$$M_u = \sqrt{(M_{ux})^2 + (M_{uy})^2} \quad e = \sqrt{(e_x)^2 + (e_y)^2}$$

2. For square and rectangular sections,

$$\frac{1}{P_n} = \frac{1}{P_{nx}} + \frac{1}{P_{ny}} - \frac{1}{P_{n0}}$$

$$\frac{M_{nx}}{M_{0x}} + \frac{M_{ny}}{M_{0y}} \leq 1.0$$

3. In the Bresler load contour method,

$$\left(\frac{M_{nx}}{M_{0x}}\right)^{1.5} + \left(\frac{M_{ny}}{M_{0y}}\right)^{1.5} = 1.0$$

4. In the PCA load contour method,

$$M_{ny} + M_{nx} \left(\frac{b}{h}\right) \left(\frac{1-\beta}{\beta}\right) = M_{0y}$$

$$M_{nx} + M_{ny} \left(\frac{h}{b}\right) \left(\frac{1-\beta}{\beta}\right) = M_{0x}$$

5. Equations of failure surface method are given with applications.

## REFERENCES

1. B. Brester. *Reinforced Concrete Engineering*, vol. 1. Wiley, New York, 1974.
2. E. O. Pfrang, C. P. Siess, and M. A. Sozen. "Load-Moment-Curvature Characteristics of Reinforced Concrete Cross-Sections." *ACI Journal* 61 (July 1964).
3. F. E. Richart, J. O. Draffin, T. A. Olson, and R. H. Heitman. *The Effect of Eccentric Loading, Protective Shells, Slenderness Ratio, and Other Variables in Reinforced Concrete Columns*. Bulletin no. 368. Engineering Experiment Station, University of Illinois, Urbana, 1947.
4. N. G. Bunni. "Rectangular Ties in Reinforced Concrete Columns." In *Reinforced Concrete Columns*. Publication no. SP-50. American Concrete Institute, Detroit, MI, 1975.
5. C. S. Whitney. "Plastic Theory of Reinforced Concrete." *Transactions ASCE* 107 (1942).
6. Concrete Reinforcing Steel Institute (CRSI). *CRSI Handbook*. CRSI, Chicago, IL, 1992.
7. American Concrete Institute (ACI). *The Reinforced Concrete Design Manual*, vol. 1, ACI Publication SP-17(11). ACI, Detroit, MI, 2011.
8. Portland Cement Association (PCA). *Ultimate Load Tables for Circular Columns*. PCA, Chicago, IL, 1968.
9. B. Bresler. "Design Criteria for Reinforced Concrete Columns." *ACI Journal* 57 (November 1960).
10. R. Furlong. "Ultimate Strength of Square Columns Under Biaxially Eccentric Loads." *ACI Journal* 57 (March 1961).
11. A. L. Parme, J. M. Nieves, and A. Gouwens. "Capacity of Reinforced Rectangular Columns Subjected to Biaxial Bending." *ACI Journal* 63 (September 1966).
12. J. F. Fleming and S. D. Werner. "Design of Columns Subjected to Biaxial Bending." *ACI Journal* 62 (March 1965).
13. M. N. Hassoun. *Ultimate-Load Design of Reinforced Concrete*. View Point Publication. Cement and Concrete Association, London, 1981.
14. M. N. Hassoun. *Design Tables of Reinforced Concrete Members*. Cement and Concrete Association, London, 1978.
15. American Concrete Institute (ACI), *Building Code Requirements for Reinforced Concrete*. ACI 318-63. ACI, Detroit, MI, 1963.
16. C. T. Hsu. "Analysis and Design of Square and Rectangular Columns by Equation of Failure Surface." *ACI Structural Journal* (March-April 1988): 167-179.
17. American Concrete Institute (ACI). *Building Code Requirements for Structure Concrete*. ACI 318-14. ACI, Detroit, MI, 2014.

## PROBLEMS

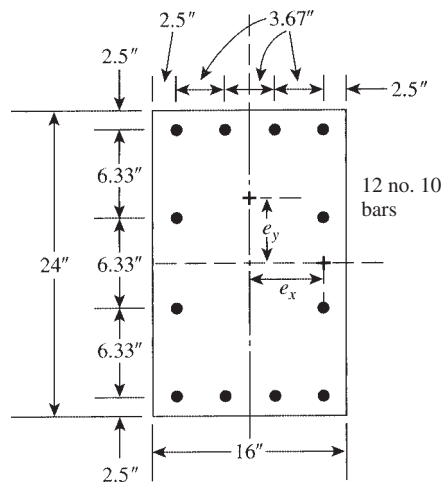
*Note:* For all problems, use  $f_y = 60$  ksi,  $d' = 2.5$  in., and  $A_s = A'_s$  where applicable. Slight variations in answers are expected.

- 11.1 (Rectangular sections: balanced condition) For the rectangular column sections given in Table 11.3, determine the balanced compressive load,  $P_b$ , the balanced moment,  $M_b$ , and the balanced eccentricity,  $e_b$ , for each assigned problem. (Answers are given in Table 11.3.) ( $\phi = 0.65$ .)
- 11.2 (Rectangular sections: compression failure) For the rectangular column sections given in Table 11.3, determine the load capacity,  $P_n$ , for each assigned problem when the eccentricity is  $e = 6$  in. (Answers are given in Table 11.3.)
- 11.3 (Rectangular sections: tension failure) For the rectangular column sections given in Table 11.3, determine the load capacity,  $P_n$ , for each assigned problem when the eccentricity is  $e = 24$  in. (Answers are given in Table 11.3.)

**Table 11.3** Answers for Problems 11.1-11.3

Number	$f'_c$ (ksi)	$b$ (in.)	$h$ (in.)	$A_s = A'_s$	Answers			
					Problem 11.1		Problem 11.2	Problem 11.3
					$P_b$	$e_b$	$P_n$ ( $e = 6$ in.)	$P_n$ ( $e = 24$ in.)
a	4	20	20	6 no. 10	572	17.4	1193	395
b	4	14	14	4 no. 8	249	10.9	407	93
c	4	24	24	8 no. 10	848	20.1	1860	696
d	4	18	26	6 no. 10	698	20.6	1528	591
e	4	12	18	4 no. 9	305	15.2	592	176
f	4	14	18	4 no. 10	354	16.2	715	221
g	5	16	16	5 no. 10	406	15.3	807	228
h	5	18	18	5 no. 9	540	12.5	930	230
i	5	14	20	4 no. 9	476	13.4	847	221
j	5	16	22	4 no. 10	606	14.8	1140	327
k	6	16	24	5 no. 10	746	16.8	1532	476
l	6	14	20	4 no. 9	534	12.8	944	226

- 11.4** (Rectangular sections with side bars) Determine the load capacity,  $\phi P_n$ , for the column section shown in Fig. 11.32 considering all side bars when the eccentricity is  $e_y = 8$  in. Use  $f'_c = 4$  ksi and  $f_y = 60$  ksi. (Answer: 658 K.)

**Figure 11.32** Problem 11.4.

- 11.5** Repeat Problem 11.4 with Fig. 11.33. (Answer: 660 K.)

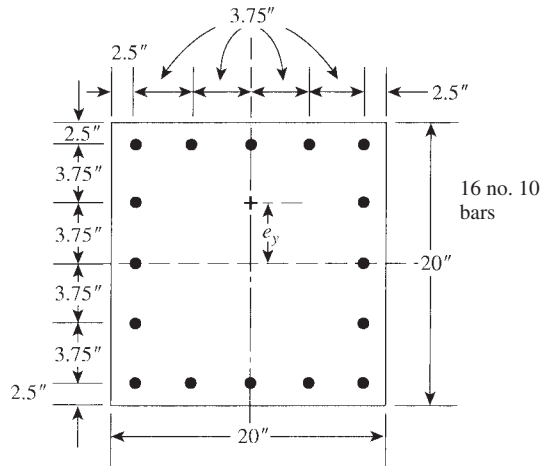


Figure 11.33 Problem 11.5.

11.6 Repeat Problem 11.4 with Fig. 11.34. (Answer: 368 K.)

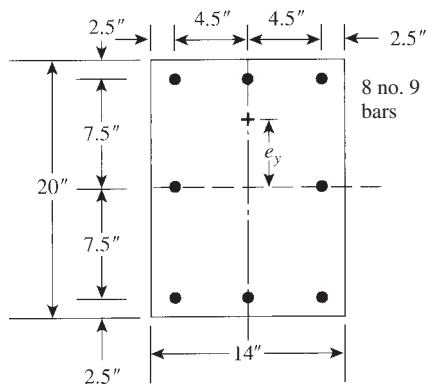


Figure 11.34 Problem 11.6.

11.7 Repeat Problem 11.4 with Fig. 11.35. (Answer: 822 K.)

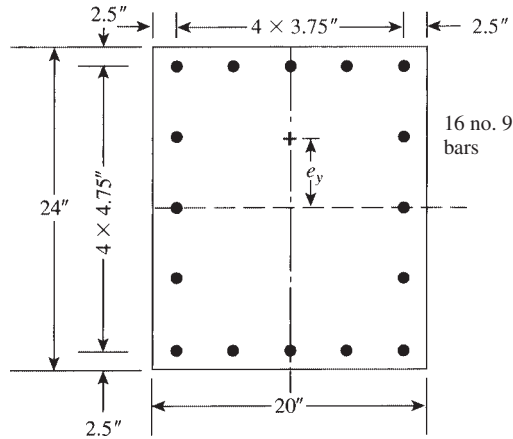


Figure 11.35 Problem 11.7.

**11.8** (Design of rectangular column sections) For each assigned problem in Table 11.4, design a rectangular column section to support the factored load and moment shown. Determine  $A_s, A'_s$ , and  $h$  if not given; then choose adequate bars considering that  $A_s = A'_s$ . The final total steel ratio,  $\rho_g$ , should be close to the given values where applicable. Check the load capacity,  $\phi P_n$ , of the final section using statics and equilibrium equations. One solution for each problem is given in Table 11.4.

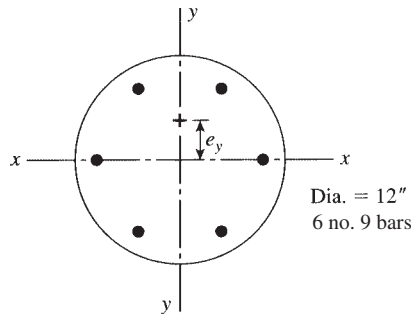
**11.9** (ACI charts) Repeat Problems 11.2b, 11.2d, 11.2f, 11.8a, 11.8c, and 11.8e using the ACI charts.

**11.10** (Circular columns: balanced condition) Determine the balanced load capacity,  $\phi P_b$ , the balanced moment,  $\phi M_b$ , and the balanced eccentricity,  $e_b$ , for the circular tied sections shown in Fig. 11.36. Use  $f'_c = 4$  ksi and  $f_y = 60$  ksi.

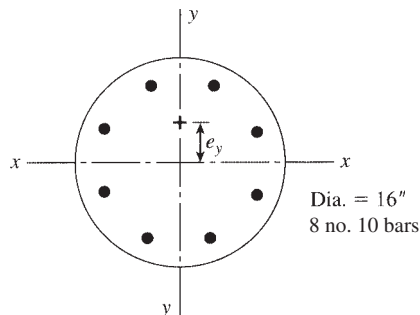
**11.11** Repeat Problem 11.10 for Fig. 11.37.

**Table 11.4** Problem 11.8

Number	$f'_c$ (ksi)	$P_u$ (K)	$M_u$ (K · ft)	$b$ (in.)	$h$ (in.)	$\rho_g$ %	One Solution	
							$h$ (in.)	$A_s - A'_s$
a	4	530	353	16	—	4.0	20	5 no. 10
b	4	410	205	14	18	—	18	5 no. 8
c	4	480	640	18	—	3.5	24	6 no. 10
d	4	440	440	20	20	—	20	6 no. 9
e	4	1125	375	20	24	—	24	6 no. 10
f	4	710	473	18	—	3.0	24	5 no. 10
g	5	300	300	14	—	2.0	20	3 no. 9
h	5	1000	665	20	26	—	26	6 no. 10
i	6	590	197	14	—	2.0	18	2 no. 10
j	6	664	332	16	20	—	20	4 no. 9



**Figure 11.36** Problem 11.10.



**Figure 11.37** Problem 11.11.

11.12 Repeat Problem 11.10 for Fig. 11.38.

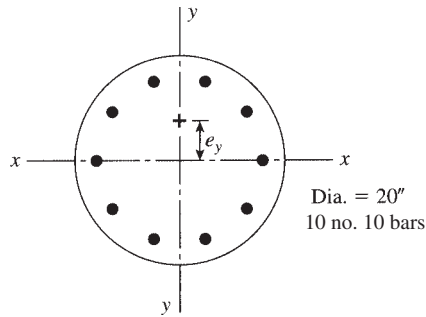


Figure 11.38 Problem 11.12.

11.13 Repeat Problem 11.11 for Fig. 11.39.

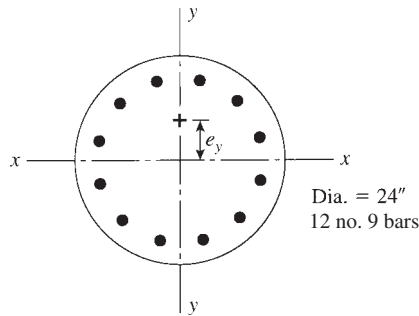


Figure 11.39 Problem 11.13.

11.14 (Circular columns) Determine the load capacity,  $\phi P_n$ , for the circular tied column sections shown in Figs. 11.36 through 11.39 when the eccentricity is  $e_y = 6$  in. Use  $f'_c = 4$  ksi and  $f_y = 60$  ksi.

11.15 (Biaxial bending) Determine the load capacity,  $P_n$ , for the column sections shown in Figs. 11.32 through 11.35 if  $e_y = 8$  in. and  $e_x = 6$  in. using the Bresler reciprocal method. Use  $f'_c (4$  ksi) and  $f_y = 60$  ksi. For each problem the values of  $P_{nx}$ ,  $P_{ny}$ ,  $P_{n0}$  ( $P_{bx}$ ,  $M_{bx}$ ), and ( $P_{by}$ ,  $M_{by}$ ) are as follows:

- a. Figure 11.32: 952 K, 835 K, 2168 K (571 K, 792 K · ft), (536 K, 483 K · ft).
- b. Figure 11.33: 930 K, 1108 K, 2505 K (577 K, 742 K · ft), (577 K, 742 K · ft).
- c. Figure 11.34: 558 K, 495 K, 1408 K (408 K, 414 K · ft), (368 K, 260 K · ft).
- d. Figure 11.35: 1093 K, 1145 K, 2538 K (718 K, 865 K · ft), (701 K, 699 K · ft).

11.16 Repeat Problem 11.15 using the Parme method.

11.17 Repeat Problem 11.15 using the Hsu method.

11.18 For the column sections shown in Fig. 11.32, determine

- a. The uniaxial load capacities about the  $x$  and  $y$  axes,  $P_{nx}$  and  $P_{ny}$  using  $e_y = 6$  in. and  $e_x = 6$  in.
- b. The uniaxial balanced load and moment capacities about the  $x$  and  $y$  axes,  $P_{bx}$ ,  $P_{by}$ ,  $M_{bx}$ , and  $M_{by}$ .
- c. The axial load,  $P_{n0}$ .
- d. The biaxial load capacity  $P_n$  when  $e_y = e_x = 6$  in., using the Bresler reciprocal method, the Hsu method, or both.

11.19 Repeat Problem 11.18 for Fig. 11.33.

11.20 Repeat Problem 11.18 for Fig. 11.34.

11.21 Repeat Problem 11.18 for Fig. 11.35.

# CHAPTER 12

## SLENDER COLUMNS



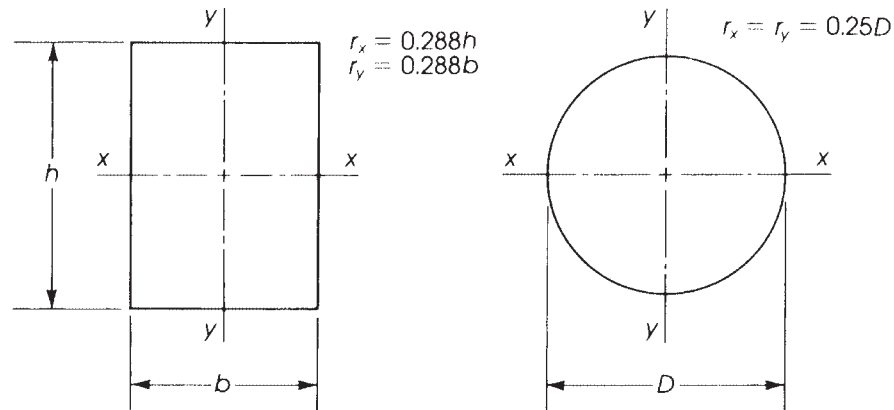
Columns in a high-rise building.

### 12.1 INTRODUCTION

In the analysis and design of short columns discussed in the previous two chapters, it was assumed that buckling, elastic shortening, and secondary moment due to lateral deflection had minimal effect on the ultimate strength of the column; thus, these factors were not included in the design procedure. However, when the column is long, these factors must be considered. The extra length will cause a reduction in the column strength that varies with the column effective height, width of the section, the slenderness ratio, and the column end conditions.

A column with a high slenderness ratio will have a considerable reduction in strength, whereas a low slenderness ratio means that the column is relatively short and the reduction in strength may





**Figure 12.1** Rectangular and circular sections of columns, with radius of gyration  $r$ .

not be significant. The slenderness ratio is the ratio of the column height,  $l$ , to the radius of gyration,  $r$ , where  $r = \sqrt{I/A}$ ,  $I$  being the moment of inertia of the section and  $A$  the sectional area.

For a rectangular section of width  $b$  and depth  $h$  (Fig. 12.1),  $I_x = bh^3/12$  and  $A = bh$ . Therefore,  $r_x = \sqrt{I/A} = 0.288h$  (or, approximately,  $r_x = 0.3h$ ). Similarly,  $I_y = hb^3/12$  and  $r_y = 0.288b$  (or, approximately,  $0.3b$ ). For a circular column with diameter  $D$ ,  $I_x = I_y = \pi D^2/64$  and  $A = \pi D^2/4$ ; therefore,  $r_x = r_y = 0.25D$ .

In general, columns may be considered as follows:

1. Long with a relatively high slenderness ratio, where lateral bracing or shear walls are required.
2. Long with a medium slenderness ratio that causes a reduction in the column strength. Lateral bracing may not be required, but strength reduction must be considered.
3. Short where the slenderness ratio is relatively small, causing a slight reduction in strength. This reduction may be neglected, as discussed in previous chapters.

## 12.2 EFFECTIVE COLUMN LENGTH ( $KL_u$ )

The slenderness ratio  $l/r$  can be calculated accurately when the effective length of the column ( $Kl_u$ ) is used. This effective length is a function of two main factors:

1. The unsupported length,  $l_u$ , represents the unsupported height of the column between two floors. It is measured as the clear distance between slabs, beams, or any structural member providing lateral support to the column. In a flat slab system with column capitals, the unsupported height of the column is measured from the top of the lower floor slab to the bottom of the column capital. If the column is supported with a deeper beam in one direction than in the other direction,  $l_u$  should be calculated in both directions (about the  $x$  and  $y$  axes) of the column section. The critical (greater) value must be considered in the design.
2. The effective length factor,  $K$ , represents the ratio of the distance between points of zero moment in the column and the unsupported height of the column in one direction. For example, if the unsupported length of a column hinged at both ends, on which sidesway is prevented, is  $l_u$ , the points of zero moment will be at the top and bottom of the column—that

is, at the two hinged ends. Therefore, the factor  $K = l_u/l_u$  is 1.0. If a column is fixed at both ends and sidesway is prevented, the points of inflection (points of 0 moment) are at  $l_u/4$  from each end. Therefore,  $K = 0.5l_u/l_u = 0.5$  (Fig. 12.2). To evaluate the proper value of  $K$ , two main cases are considered.

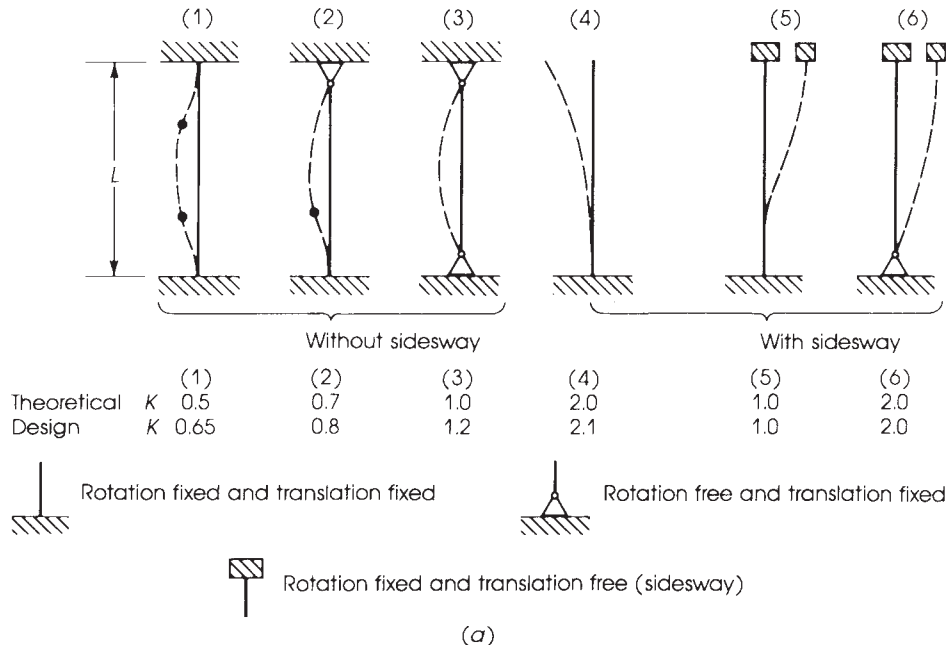
When structural frames are braced, the frame, which consists of beams and columns, is braced against sidesway by shear walls, rigid bracing, or lateral support from an adjoining structure. The ends of the columns will stay in position, and lateral translation of joints is prevented. The range of  $K$  in braced frames is always equal to or less than 1.0. The ACI Code, Section 6.2.5, recommends the use of  $K = 1.0$  for braced frames.

When the structural frames are unbraced, the frame is not supported against sidesway, and it depends on the stiffness of the beams and columns to prevent lateral deflection. Joint translations are not prevented, and the frame sways in the direction of lateral loads. The range of  $K$  for different columns and frames is given in Fig. 12.2, considering the two cases when sidesway is prevented or not prevented.

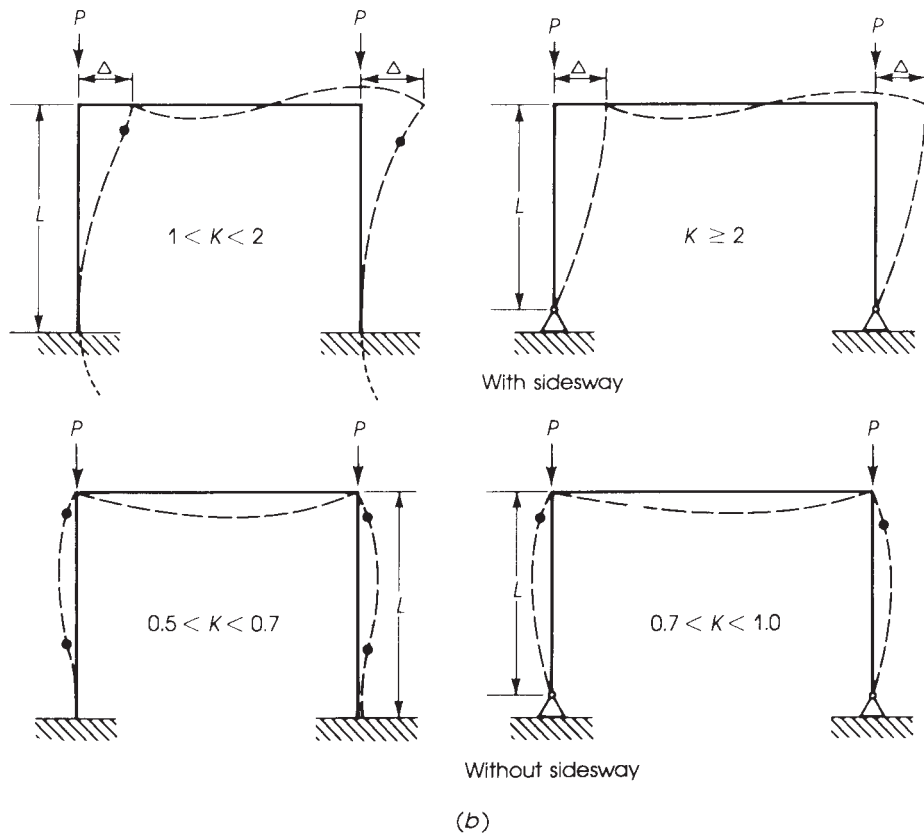
### 12.3 EFFECTIVE LENGTH FACTOR (K)

The effective length of columns can be estimated by using the alignment chart shown in Fig. 12.3 [10]. To find the effective length factor  $K$ , it is necessary first to calculate the end restraint factors  $\psi_A$  and  $\psi_B$  at the top and bottom of the column, respectively, where

$$\psi = \frac{\sum EI/l_c \text{ of columns}}{\sum EI/l \text{ of beams}} \tag{12.1}$$



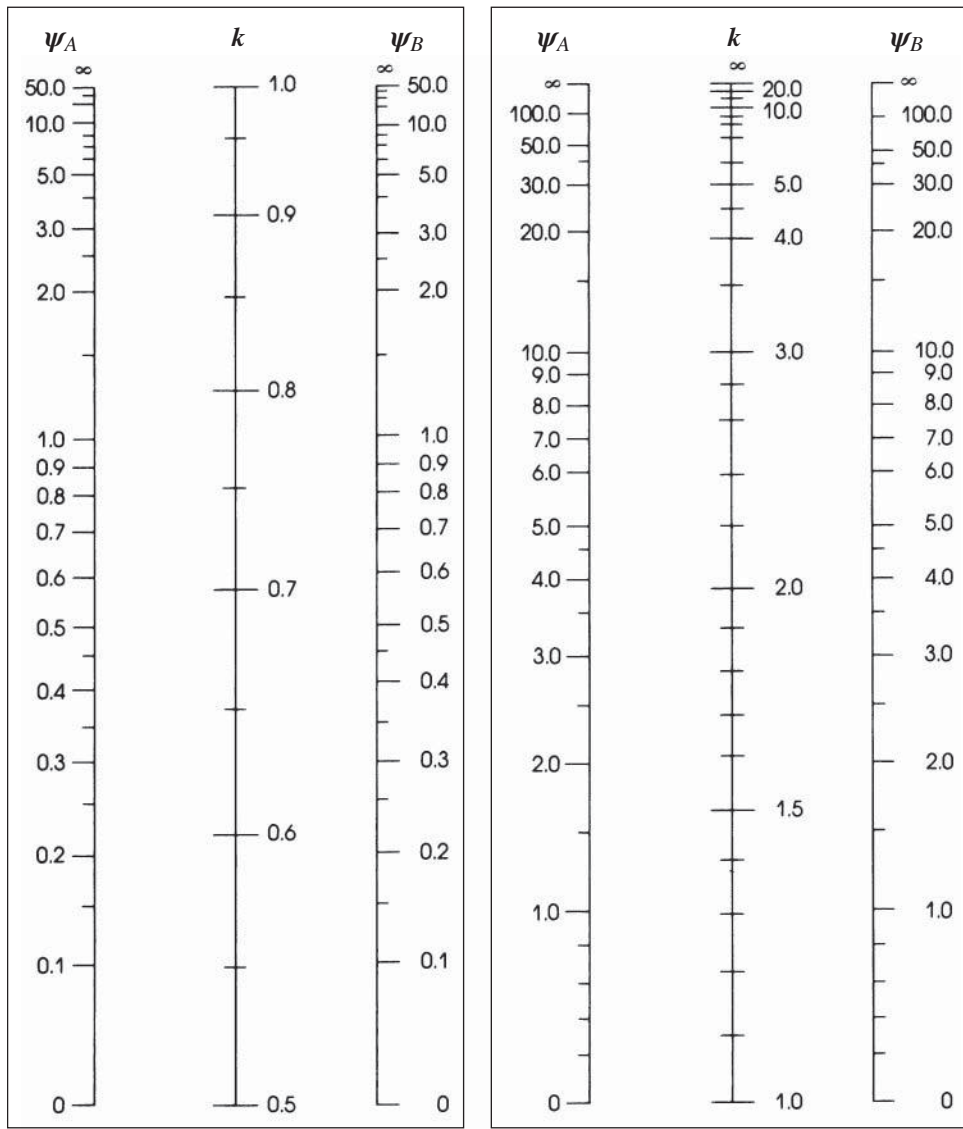
**Figure 12.2** (a) Effective lengths of columns and length factor  $K$  and (b) effective lengths and  $K$  for portal columns.



**Figure 12.2** (Continued)

(both in the plane of bending) where  $l_c$  is length center to center of joints in a frame and  $l$  is the span length of flexure, center to center of joints. The  $\psi$  factor at one end shall include all columns and beams meeting at the joint. For a hinged end,  $\psi$  is infinite and may be assumed to be 10.0. For a fixed end,  $\psi$  is zero and may be assumed to be 1.0. Those assumed values may be used because neither a perfect frictionless hinge nor perfectly fixed ends can exist in reinforced concrete frames.

The procedure for estimating  $K$  is to calculate  $\psi_A$  for the top end of the column and  $\psi_B$  for the bottom end of the column. Plot  $\psi_A$  and  $\psi_B$  on the alignment chart of Fig. 12.3 and connect the two points to intersect the middle line, which indicates the  $K$  value. Two nomograms are shown, one for braced frames where sidesway is prevented, and the second for unbraced frames, where sidesway is not prevented. The development of the charts is based on the assumptions that (1) the structure consists of symmetrical rectangular frames, (2) the girder moment at a joint is distributed to columns according to their relative stiffnesses, and (3) all columns reach their critical loads at the same time.



Nonsway frames

Sway frames

$\Psi$  = ratio of  $\Sigma (EII_c)$  of compression members to  $\Sigma (EII)$  of flexural members in a plane at one end of a compression member  
 $\ell$  = span length of flexural member measured center to center of joints

**Figure 12.3** Alignment chart to calculate effective length factor,  $k$ . Courtesy of ACI



Long columns in an office building.

## 12.4 MEMBER STIFFNESS ( $EI$ )

The stiffness of a structural member is equal to the modulus of elasticity  $E$  times the moment of inertia  $I$  of the section. The values of  $E$  and  $I$  for reinforced concrete members can be estimated as follows:

1. The modulus of elasticity of concrete was discussed in Chapter 2; the ACI Code gives the following expression:

$$E_c = 33w^{1.5}\sqrt{f'_c} \quad \text{or} \quad E_c = 57,000\sqrt{f'_c} \text{ (psi)}$$

for normal-weight concrete. The modulus of elasticity of steel is  $E_s = 29 \times 10^6$  psi.

2. For reinforced concrete members, the moment of inertia  $I$  varies along the member, depending on the degree of cracking and the percentage of reinforcement in the section considered.

To evaluate the factor  $\psi$ ,  $EI$  must be calculated for beams and columns. For this purpose,  $I$  can be estimated as follows (ACI Code, Section 6.6.3.1.1):

- a. Compression members:

$$\text{Columns } I = 0.70I_g$$

$$\text{Walls – Uncracked } I = 0.70I_g$$

$$\text{–Cracked } I = 0.35I_g$$

- b. Flexural members:

$$\text{Beams } I = 0.35I_g$$

$$\text{Flat plates and flat slabs } I = 0.25I_g$$

Alternatively, the moments of inertia of compression and flexural members,  $I$  shall be permitted to be computed as follows:

- c. Compression members:

$$I = \left(0.80 + 25 \frac{A_{st}}{A_g}\right) \left(1 - \frac{M_u}{P_u h} - 0.5 \frac{P_u}{P_0}\right) I_g \leq 0.875I_g \quad (12.2)$$

where  $P_u$  and  $M_u$  shall be determined from the particular load combination under consideration, or the combination of  $P_u$  and  $M_u$  determined in the smallest value of  $I$ ,  $I$  need not be taken less than  $0.35I_g$ .

- d. Flexural members:

$$I = (0.10 + 25\rho) \left(1.2 - 0.2 \frac{b_w}{d}\right) I_g \leq 0.5I_g \quad (12.3)$$

where  $I_g$  is the moment of inertia of the gross concrete section about the centroidal axis, neglecting reinforcement.

$$\rho = \text{ratio of } \frac{A_s}{bd} \text{ in cross section}$$

The moment of inertia of T-beams should be based on the effective flange width defined in Section 8.12. It is generally sufficiently accurate to take  $I_g$  of a T-beam as two times the  $I_g$  of the web,  $2(b_w h^3/12)$ .

If the factored moments and shears from an analysis based on the moment of inertia of a wall, taken equal to  $0.70I_g$ , indicate that the wall will crack in flexure, based on the modulus of rupture, the analysis should be repeated with  $I = 0.35I_g$  in those stories where cracking is predicted using factored loads.

The values of the moments of inertia were derived for non-prestressed members. For prestressed members, the moments of inertia may differ depending on the amount, location, and type of the reinforcement and the degree of cracking prior to ultimate. The stiffness value for prestressed concrete members should include an allowance for the variability of the stiffnesses.

For continuous flexural members,  $I$  shall be permitted to be taken as the average of values obtained from Eq.12.3 for the critical positive and negative moment sections. Moment of inertia  $I$  need not be taken less than  $0.25I_g$ .

The cross-sectional dimensions and reinforcement ratio used in the above formulas shall be within 10% of the dimensions and reinforcement ratio shown on the contract documents or the stiffness evaluation shall be repeated.

3. Area,  $A = 1.0 A_g$  (cross-sectional area).
4. The moments of inertia shall be divided by  $(1 + \beta_{dns})$  when sustained lateral loads act on the structure or for stability check, where

$$\beta_{dns} = \frac{\text{maximum factored axial sustained load}}{\text{maximum factored axial load}} = \frac{1.2D \text{ (sustained)}}{1.2D + 1.6L} \leq 1.0 \quad (12.4)$$

## 12.5 LIMITATION OF THE SLENDERNESS RATIO ( $Kl_u/r$ )

### 12.5.1 Nonsway Frames

The ACI Code, Section 6.2.5, recommends the following limitations between short and long columns in braced (nonsway) frames:

1. The effect of slenderness may be neglected and the column may be designed as a short column when

$$\frac{Kl_u}{r} \leq 34 - \frac{12M_1}{M_2} \leq 40 \quad (12.5)$$

where  $M_1$  and  $M_2$  are the factored end moments of the column and  $M_2$  is greater than  $M_1$ .

2. The ratio  $M_1/M_2$  is considered positive if the member is bent in single curvature and negative for double curvature (Fig. 12.4).
3. The term  $34 - 12M_1/M_2$  shall not be taken greater than 40.

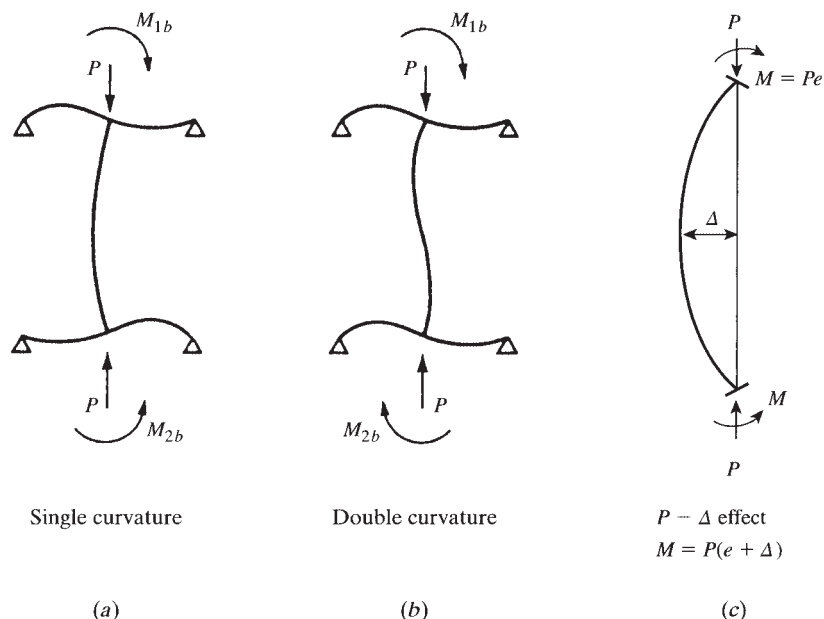


Figure 12.4 Single and double curvatures.

4. If the factored column moments are zero or  $e = M_u/P_u < e_{\min}$ , the value of  $M_2$  shall not be taken less than  $M_{2,\min}$  calculated using the minimum eccentricity given by ACI Code, Section 6.6.4.5.4:

$$e_{\min} = 0.6 + 0.03h \quad (\text{inch}) \quad (12.6)$$

$$M_{2,\min} = P_u(0.6 + 0.03h) \quad (12.7)$$

where  $M_{2,\min}$  is the minimum moment and  $e_{\min}$  is the minimum eccentricity. The moment  $M_2$  shall be considered about each axis of the column separately. The value of  $K$  may be assumed to be equal to 1.0 for a braced frame unless it is calculated on the basis of  $EI$  analysis.

5. It shall be permitted to consider compression members braced against sidesway when bracing elements have a total stiffness, resisting lateral movement of that story, of at least 12 times the gross stiffness of the columns within the story.

### 12.5.2 Sway Frames

In compression members not braced (sway) against sidesway, the effect of the slenderness ratio may be neglected when

$$\frac{Kl_u}{r} \leq 22 \quad (\text{ACI Code, Section 6.2.5}) \quad (12.8)$$

## 12.6 MOMENT-MAGNIFIER DESIGN METHOD

### 12.6.1 Introduction

The first step in determining the design moments in a long column is to determine whether the frame is braced or unbraced against sidesway. If lateral bracing elements, such as shear walls and shear trusses, are provided or the columns have substantial lateral stiffness, then the lateral deflections produced are relatively small and their effect on the column strength is substantially low. It can be assumed (ACI Code, Section 6.6.4.4.1) that a story within a structure is nonsway if

$$Q = \frac{\sum P_u \Delta_0}{V_{us} l_c} \leq 0.05 \quad (12.9)$$

where  $\sum P_u$  and  $V_{us}$  are the story total factored vertical load and horizontal story shear in the story being evaluated, respectively, and  $\Delta_0$  is the first-order relative lateral deflection between the top and bottom of the story due to  $V_{us}$ . The length  $l_c$  is that of the compression member in a frame, measured from center to center of the joints in the frame.

In general, compression members may be subjected to lateral deflections that cause secondary moments. If the secondary moment,  $M'$ , is added to the applied moment on the column,  $M_a$ , the final moment is  $M = M_a + M'$ . An approximate method for estimating the final moment  $M$  is to multiply the applied moment  $M_a$  by a factor called the *magnifying moment factor*  $\delta$ , which must be equal to or greater than 1.0, or  $M_{\max} = \delta M_a$  and  $\delta \geq 1.0$ . The moment  $M_a$  is obtained from the elastic structural analysis using factored loads, and it is the maximum moment that acts on the column at either end or within the column if transverse loadings are present.

If the  $P-\Delta$  effect is taken into consideration, it becomes necessary to use a second-order analysis to account for the nonlinear relationship between the load, lateral displacement, and the moment. This is normally performed using computer programs. The ACI Code permits the use of first-order analysis of columns. The ACI Code *moment-magnifier design method* is a simplified approach for calculating the moment-magnifier factor in both braced and unbraced frames.



### 12.6.2 Magnified Moments in Nonway Frames

The effect of the slenderness ratio  $Kl_u/r$  in a compression member of a braced frame may be ignored if  $Kl_u/r \leq 34 - 12 M_1/M_2 \leq 40$ , as given in Section 6.2.5. If  $Kl_u/r$  is greater than  $34 - 12 M_1/M_2$ , then the slenderness effect must be considered. The procedure for determining the magnification factor  $\delta_{ns}$  in nonway frames can be summarized as follows (ACI Code, Section 6.6.4):

1. Determine if the frame is braced against sidesway and find the unsupported length,  $l_u$ , and the effective length factor,  $K$  ( $K$  may be assumed to be 1.0).
2. Calculate the member stiffness,  $EI$ , using the reasonably approximate equation

$$EI = \frac{0.2E_c I_g + E_s I_{se}}{1 + \beta_{dns}} \quad (12.10)$$

or the more simplified approximate equation

$$EI = \frac{0.4E_c I_g}{1 + \beta_{dns}} \quad (12.11)$$

$$EI = 0.25E_c I_g \quad (\text{for } \beta_{dns} = 0.6) \quad (12.12)$$

where

$$E_c = 57,000 \sqrt{f'_c}$$

$$E_s = 29 \times 10^6 \text{ psi}$$

$I_g$  = gross moment of inertia of the section about the axis considered, neglecting  $A_{st}$

$I_{se}$  = moment of inertia of the reinforcing steel

$$\beta_{dns} = \frac{\text{maximum factored axial sustained load}}{\text{maximum factored axial load}} = \frac{1.2D(\text{sustained})}{1.2D + 1.6L}$$

*Note:* The above  $\beta_{dns}$  is the ratio used to compute magnified moments in columns due to sustained loads.

Equations 12.11 and 12.12 are less accurate than Eq. 12.10. Moreover, Eq. 12.12 is obtained by assuming  $\beta_d = 0.6$  in Eq. 12.11.

For improved accuracy  $EI$  can be approximated using suggested  $E$  and  $I$  values from Eq. 12.2 divided by  $1 + \beta_{dns}$ :

$$I = \left(0.80 + 25 \frac{A_{st}}{A_g}\right) \left(1 - \frac{M_u}{P_u h} - 0.5 \frac{P_u}{P_0}\right) I_g \leq 0.875 I_g \quad (12.12)$$

$I$  need not be taken less than  $0.35 I_g$

where

$A_{st}$  = total area of longitudinal reinforcement (in.<sup>2</sup>)

$P_0$  = nominal axial strength at zero eccentricity (lb)

$P_u$  = factored axial force (+ve for compression) (lb)

$M_u$  = factored moment at section (lb.in.)

$h$  = thickness of member (in.)

3. Determine the Euler buckling load,  $P_c$ :

$$P_c = \frac{\pi^2 EI}{(Kl_u)^2} \quad (12.13)$$

Use the values of  $EI$ ,  $K$ , and  $l_u$  as calculated from steps 1 and 2.

4. Calculate the value of the factor  $C_m$  to be used in the equation of the moment-magnifier factor. For braced members without transverse loads,

$$C_m = 0.6 + \frac{0.4M_1}{M_2} \quad (12.14)$$

where  $M_1/M_2$  is positive if the column is bent in single curvature and negative if the member is bent in double curvature. For members in which  $M_{2,\min} = P_u(0.6 + 0.03h)$  exceeds  $M_2$ , the value of  $C_m$  in Eq.12.14 shall either be taken equal to 1, or shall be based on the ratio of computed end moments,  $M_1/M_2$ .

5. Calculate the moment magnifier factor  $\delta_{ns}$ :

$$\delta_{ns} = \frac{C_m}{1 - (P_u/0.75P_c)} \geq 1.0 \quad (12.15)$$

where  $P_u$  is the applied factored load and  $P_c$  and  $C_m$  are as calculated previously.

6. Design the compression member using the axial factored load,  $P_u$ , from the conventional frame analysis and a magnified moment,  $M_c$ , computed as follows:

$$M_c = \delta_{ns} M_2 \quad (12.16)$$

where  $M_2$  is the larger factored end moment due to loads that result in no sidesway and should be  $\geq M_{2,\min} = P_u(0.6 + 0.03h)$ . For frames braced against sidesway, the sway factor is  $\delta_s = 0$ . In nonsway frames, the lateral deflection is expected to be less than or equal to  $H/1500$ , where  $H$  is the total height of the frame.

### 12.6.3 Magnified Moments in Sway Frames

The effect of slenderness may be ignored in sway (unbraced) frames when  $Kl_u/r < 22$ . The procedure for determining the magnification factor,  $\delta_s$ , in sway (unbraced) frames may be summarized as follows (ACI Code, Section 6.6.4.6):

1. Determine if the frame is unbraced against sidesway and find the unsupported length  $l_u$  and  $K$ , which can be obtained from the alignment charts (Fig. 12.3).
- 2-4. Calculate  $EI$ ,  $P_c$ , and  $C_m$  as given by Eqs. 12.2 and Eqs. 12.10 through 12.14. Note that the term  $\beta_{ds}$  is used instead of  $\beta_{dns}$  to calculate  $I$  and is defined as the ratio of maximum factored sustained shear within a story to the total factored shear in that story.
5. Calculate the moment-magnifier factor,  $\delta_s$  using one of the following methods:
  - a. Magnifier method:

$$\delta_s = \frac{1}{1 - (\sum P_u/0.75 \sum P_c)} \geq 1.0 \quad (12.17)$$

where  $\delta_s \leq 2.5$  and  $\sum P_u$  is the summation for all the factored vertical loads in a story and  $\sum P_c$  is the summation for all sway-resisting columns in a story. Also,

$$\delta_s M_s = \frac{M_s}{1 - (\sum P_u/0.75 \sum P_c)} \geq M_s \quad (12.18)$$

where  $M_s$  is the factored end moment due to loads causing appreciable sway.

- b. Approximate second-order analysis:

$$\delta_s = \frac{1}{1 - Q} \geq 1 \quad \text{or} \quad \delta_s M_s = \frac{M_s}{1 - Q} \geq M_s \quad (12.19)$$

where

$$Q = \frac{\sum P_u \Delta_0}{V_{us} l_c} \quad (12.20)$$

where

$P_u$  = factored axial load (lb)

$\Delta_0$  = relative lateral deflection between the top and bottom of a story due to lateral forces using first-order elastic frame analysis (in.)

$V_{us}$  = factored horizontal shear in a story (lb)

$l_c$  = length of compression member in a frame (in.)

If  $\delta_s$  exceeds 1.5,  $\delta_s$  shall be calculated using second-order elastic analysis or the magnifier method described in (a).

6. Calculate the magnified end moments  $M_1$  and  $M_2$  at the ends of an individual compression member, as follows:

$$M_1 = M_{1ns} + \delta_s M_{1s} \quad (12.21)$$

$$M_2 = M_{2ns} + \delta_s M_{2s} \quad (12.22)$$

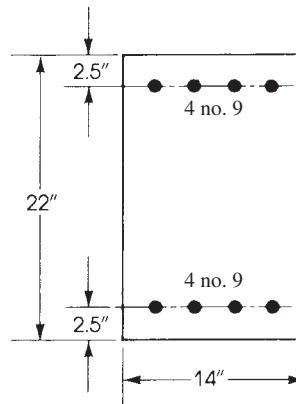
where  $M_{1ns}$  and  $M_{2ns}$  are the moments obtained from the no-sway condition, whereas  $M_{1s}$  and  $M_{2s}$  are the moments obtained from the sway condition. The design magnified moment  $M_c$  is the larger between  $M_1$  and  $M_2$ .



Columns, University of Wisconsin, Madison, Wisconsin.

**Example 12.1**

The column section shown in Fig. 12.5 carries an axial load  $P_D = 136$  K and a moment  $M_D = 116$  K·ft due to dead load and an axial load  $P_L = 110$  K and a moment  $M_L = 93$  K·ft due to live load. The column is part of a frame that is braced against sidesway and bent in single curvature about its major axis. The unsupported length of the column is  $l_c = 19$  ft, and the moments at both ends of the column are equal. Check the adequacy of the column using  $f'_c = 4$  ksi and  $f_y = 60$  ksi.



**Figure 12.5** Example 12.1.

**Solution**

1. Calculate factored loads:

$$P_u = 1.2P_D + 1.6P_L = 1.2 \times 136 + 1.6 \times 110 = 339.2 \text{ K}$$

$$M_u = 1.2M_D + 1.6M_L = 1.2 \times 116 + 1.6 \times 93 = 288 \text{ K} \cdot \text{ft}$$

$$e = \frac{M_u}{P_u} = \frac{288 \times 12}{339.2} = 10.2 \text{ in.}$$

2. Check if the column is long. Because the frame is braced against sidesway, assume  $K = 1.0$ ,  $r = 0.3h = 0.3 \times 22 = 6.6$  in., and  $l_u = 19$  ft.

$$\frac{Kl_u}{r} = \frac{1 \times 19 \times 12}{6.6} = 34.5$$

For braced columns, if  $Kl_u/r \leq 34 - 12M_1/M_2$ , slenderness effect may be neglected. Given end moments  $M_1 = M_2$  and  $M_1/M_2$  positive for single curvature,

$$\text{Right-hand side} = 34 - 12 \frac{M_1}{M_2} = 34 - 12 \times 1 = 22$$

Because  $Kl_u/r = 34.5 > 22$ , slenderness effect must be considered

3. Calculate  $EI$  from Eq. 12.10:

- a. Calculate  $E_c$ :

$$E_c = 57,000 \sqrt{f'_c} = 57,000 \sqrt{4000} = 3605 \text{ ksi}$$

$$E_s = 29,000 \text{ ksi}$$

b. The moment of inertia is

$$I_g = \frac{14(22)^3}{12} = 12,422 \text{ in.}^4 \quad A_s = A'_s = 4.0 \text{ in.}^2$$

$$I_{se} = 2 \times 4.0 \left( \frac{22-5}{2} \right)^2 = 578 \text{ in.}^4$$

The dead-load moment ratio is

$$\beta_{dns} = \frac{1.2 \times 136}{339.2} = 0.48$$

c. The stiffness is

$$\begin{aligned} EI &= \frac{0.2E_c I_g + E_s I_{se}}{1 + \beta_{dns}} \\ &= \frac{(0.2 \times 3605 \times 12,422) + (29,000 \times 578)}{1 + 0.48} \\ &= 17.40 \times 10^6 \text{ K} \cdot \text{in.}^2 \end{aligned}$$

4. Calculate  $P_c$ :

$$P_c = \frac{\pi^2 EI}{(Kl_u)^2} = \frac{\pi^2 (17.40 \times 10^6)}{(12 \times 19)^2} = 3303 \text{ K}$$

5. Calculate  $C_m$  from Eq.12.14:

$$\begin{aligned} C_m &= 0.6 + \frac{0.4M_1}{M_2} \\ &= 0.6 + 0.4(1) = 1.0 \end{aligned}$$

6. Calculate the moment-magnifier factor from Eq.12.15:

$$\delta_{ns} = \frac{C_m}{1 - (P_u/0.75P_c)} = \frac{1}{1 - 339.2/(0.75 \times 3303)} = 1.16$$

7. Calculate the design moment and load: Assume ( $\phi = 0.65$ ),

$$\begin{aligned} P_n &= \frac{339.2}{0.65} = 522 \text{ K} \\ M_n &= \frac{288}{0.65} = 443.1 \text{ K} \cdot \text{ft} \end{aligned}$$

Design  $M_c = (1.16)288 = 334 \text{ K} \cdot \text{ft}$ . Design eccentricity  $= (334 \times 12)/339.2 = 11.82 \text{ in.}$ , or 12 in.

8. Determine the nominal load strength of the section using  $e = 12 \text{ in.}$  according to Example 11.4:

$$P_n = 47.6a + 226.4 - 4f'_s$$

$$e' = e + d - \frac{h}{2} = 12 + 19.5 - \frac{22}{2} = 20.50 \text{ in.} \quad (\text{I})$$

$$\begin{aligned} P_n &= \frac{1}{20.50} \left[ 47.6a \left( 19.5 - \frac{a}{2} \right) + 226.4(19.5 - 2.5) \right] \\ &= 45a - 1.15a^2 + 186.6 \quad (\text{II}) \end{aligned}$$

Solving for  $a$  from Eqs. I and II,  $a = 10.6 \text{ in.}$  and  $P_n = 535 \text{ K}$ . The load strength,  $P_n$ , is greater than the required load of 522 K; therefore, the section is adequate. If the section is not adequate, increase steel reinforcement.

9. Check the assumed  $\phi$ :

$$a = 10.6 \text{ in.} \quad c = 12.47 \text{ in.} \quad d_t = 19.5 \text{ in.}$$

$$\begin{aligned} \varepsilon_t &= \left( \frac{d_t - c}{c} \right) 0.003 \\ &= 0.00169 < 0.002 \\ \phi &= 0.65 \end{aligned}$$

### Example 12.2

Check the adequacy of the column in Example 12.1 if the unsupported length is  $l_u = 10$  ft. Determine the maximum nominal load on the column.

#### Solution

1. Applied loads are  $P_n = 522$  K and  $M_n = 443.1$  K.
2. Check if the column is long:  $l_u = 10$  ft,  $r = 0.3h = 0.3 \times 22 = 6.6$  in., and  $K = 1.0$  (frame is braced against sidesway).

$$\frac{Kl_u}{r} = \frac{1 \times (10 \times 12)}{6.6} = 18.2$$

$$\text{Check if } Kl_u/r \leq 34 - 12M_{1b}/M_{2b} \leq 40$$

$$\text{Right-hand side} = 34 - 12 \times 1 = 22 \leq 40$$

$$\frac{Kl_u}{r} = 18.2 \leq 22$$

Therefore, the slenderness effect can be neglected.

3. Determine the nominal load capacity of the short column, as explained in Example 11.4. From Example 11.4, the nominal compressive strength is  $P_n = 612.1$  K (for  $e = 10$  in.), which is greater than the required load of 522 K, because the column is short with  $e = 10.2$  in. (Example 12.1).

### Example 12.3

Check the adequacy of the column in Example 12.1 if the frame is unbraced (sway) against sidesway, the end-restraint factors are  $\psi_A = 0.8$  and  $\psi_B = 2.0$ , and the unsupported length is  $l_u = 16$  ft, assume a sway moment  $M_s$  of 64 K · ft.

#### Solution

1. Determine the value of  $K$  from the alignment chart (Fig. 12.3) for unbraced frames. Connect the values of  $\psi_A = 0.8$  and  $\psi_B = 2.0$ , to intersect the  $K$  line at  $K = 1.4$ .

$$\frac{Kl_u}{r} = \frac{1.4 \times (16 \times 12)}{6.6} = 40.7$$

2. For unbraced frames, if  $Kl_u/r \leq 22$ , the column can be designed as a short column. Because actual  $Kl_u/r = 40.7 > 22$ , the slenderness effect must be considered.
3. Calculate the moment magnifier  $\delta_s$ , given  $K = 1.4$ ,  $EI = 17.40 \times 10^6$  K · in.<sup>2</sup> (from Example 12.1), and

$$P_c = \frac{\pi^2 EI}{(Kl_u)^2} = \frac{\pi^2 \times 17.40 \times 10^6}{(1.4 \times 16 \times 12)^2} = 2377 \text{ K}$$

Assume factored loads are the same on all columns in the story level

$$\delta_s = \frac{1.0}{1 - \sum P_u / (0.75 \times \sum P_c)} = \frac{1.0}{1 - 339.2 / (0.75 \times 2377)} = 1.24 \geq 1.0$$

4. From Example 12.1, the applied loads are  $P_u = 339.2 \text{ K}$  and  $M_u = 288 \text{ K} \cdot \text{ft}$ , or

$$P_n = 522 \text{ K} \quad \text{and} \quad M_n = 443.1 \text{ K} \cdot \text{ft}$$

The design moment  $M_c = M_{ns} + \delta_s M_s$  hence:

$$M_c = 288 + 1.24(64) = 367.4 \text{ K} \cdot \text{ft}$$

$$e = \frac{M_c}{P_u} = \frac{367.4 \times 12}{339.2} = 13 \text{ in.}$$

5. The requirement now is to check the adequacy of a column for  $P_n = 522 \text{ K}$ ,  $M_c = 307.6 \text{ K} \cdot \text{ft}$ , and  $e = 13 \text{ in.}$  The procedure is explained in Example 11.4.  
6. From Example 11.4,

$$P_n = 47.6a + 226.4 - 4f_s$$

$$e' = e + d - \frac{h}{2} = 13 + 19.5 - \frac{22}{2} = 21.5 \text{ in.}$$

$$\begin{aligned} P_n &= \frac{1}{21.5} \left[ 47.6a \left( 19.5 - \frac{a}{2} \right) + 226.4(19.5 - 2.5) \right] \\ &= 43.16a - 1.1a^2 + 179 \quad a = 10.4 \text{ in.} \end{aligned}$$

Thus,  $c = 12.24 \text{ in.}$  and  $P_n = 508 \text{ K.}$  This load capacity of the column is less than the required  $P_n$  of 522 K. Therefore, the section is not adequate.

7. Increase steel reinforcement to four no. 10 bars on each side and repeat the calculations to get  $P_n = 568 \text{ K}$ ,  $\epsilon_t < 0.002$ , and  $\phi = 0.65$ .

### Example 12.4

Design an interior square column for the first story of an 8-story office building. The clear height of the first floor is 16 ft, and the height of all other floors is 11 ft. The building layout is in 24 bays (Fig. 12.6), and the columns are not braced against sidesway. The loads acting on a first-floor interior column due to gravity and wind are as follows:

$$\text{Axial dead load} = 300 \text{ K}$$

$$\text{Axial live load} = 100 \text{ K}$$

$$\text{Axial wind load} = 0 \text{ K}$$

$$\text{Dead} - \text{load moments} = 32 \text{ K} \cdot \text{ft (top)} \text{ and } 54 \text{ K} \cdot \text{ft (bottom)}$$

$$\text{Live} - \text{load moments} = 20 \text{ K} \cdot \text{ft (top)} \text{ and } 36 \text{ K} \cdot \text{ft (bottom)}$$

$$\text{Wind} - \text{load moments} = 50 \text{ K} \cdot \text{ft (top)} \text{ and } 50 \text{ K} \cdot \text{ft (bottom)}$$

$$EI/l \text{ for beams} = 360 \times 10^3 \text{ K} \cdot \text{in.}$$

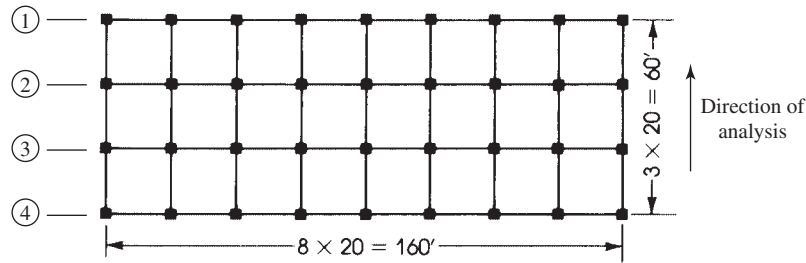


Figure 12.6 Example 12.4.

Use  $f'_c = 5$  ksi,  $f_y = 60$  ksi, and the ACI Code requirements. Assume an exterior column load of two-thirds the interior column load, a corner column load of one-third the interior column load.

**Solution**

1. Calculate the factored forces using load combinations.

For gravity loads,

$$P_u = 1.2D + 1.6L = 1.2(300) + 1.6(100) = 520 \text{ K}$$

$$M_{u,\text{top}} = M_{1\text{ns}} = 1.2M_D + 1.6M_L = 1.2(32) + 1.6(20) = 70.4 \text{ K} \cdot \text{ft}$$

$$M_{u,\text{bottom}} = M_{2\text{ns}} = 1.2M_D + 1.6M_L = 1.2(54) + 1.6(36) = 122.4 \text{ K} \cdot \text{ft}$$

For gravity plus wind load,

$$\begin{aligned} P_u &= (1.2D + 1.0L + 1.6W) \\ &= [1.2(300) + 1.0(100) + 0] = 460 \text{ K} \end{aligned}$$

$$\begin{aligned} M_{u,\text{top}} &= 1.2M_D + 1.0M_L + 1.6M_w \\ &= 1.2(32) + 1.0(20) + 1.6(50) = 138.4 \text{ K} \cdot \text{ft (top total)} \end{aligned}$$

$$M_{u,\text{tns}} = 1.2M_D + 1.0M_L = 1.2(32) + 1.0(20) = 58.4 \text{ K} \cdot \text{ft (top nonsway)}$$

$$M_{u,\text{ts}} = 1.6M_w = 1.6 \times 50 = 80 \text{ K} \cdot \text{ft (top sway)}$$

$$\begin{aligned} M_{u,\text{bottom}} &= 1.2M_D + 1.0M_L + 1.6M_w \\ &= 1.2(54) + 1.0(36) + 1.6(50) = 180.8 \text{ K} \cdot \text{ft (bottom total)} \end{aligned}$$

$$M_{u,\text{bns}} = 1.2M_D + 1.0M_L = 100.8 \text{ K} \cdot \text{ft (bottom nonsway)}$$

$$M_{u,\text{bs}} = 1.6M_w = 80 \text{ K} \cdot \text{ft (bottom sway)}$$

Other combinations are not critical.

Check for minimum  $e$ :

$$e = \frac{M_u}{P_u}$$

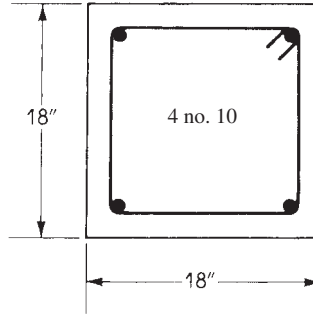
$$e \text{ for gravity loads, } e = \frac{122.4 \times 12}{520} = 2.82 \text{ in.}$$

$$e \text{ for gravity plus wind loads, } e = \frac{180.8 \times 12}{460} = 4.72 \text{ in.}$$

$$e_{\min} = 0.6 + 0.03h = 0.6 + 0.03(18) = 1.14 \text{ in.}$$

$$e > e_{\min} \quad \text{safe}$$





**Figure 12.7** Column cross section, Example 12.4.

2. Select a preliminary section of column based on gravity load combination using tables or charts. Select a section 18 × 18 in. reinforced by four no. 10 bars (Fig. 12.7).
3. Check  $Kl_u/r$ :

$$I_g = \frac{(18)^4}{12} = 8748 \text{ in.}^4 \quad E_c = 4.03 \times 10^6 \text{ psi}$$

for columns,  $I = 0.7I_g$ .

For the 16-ft floor columns,

$$\frac{EI}{l_c} = \frac{(0.7)(8748)(4.03 \times 10^6)}{16 \times 12} = 128.5 \times 10^6$$

For the 11-ft floor columns,

$$\frac{EI}{l_c} = \frac{(0.7)(8748)(4.03 \times 10^6)}{11 \times 12} = 187 \times 10^6$$

For beams,  $EI_g/l_b = 360 \times 10^6$ ,  $I = 0.35I_g$ , and  $EI/l_b = 0.35EI_g/l_c = 126 \times 10^6$ .

Analyze 18 interior columns along lines 2 and 3 with two beams framing into the direction of analysis.

$$\psi(\text{top}) = \frac{\sum(EI/l_c)}{\sum(EI/l_b)} = \frac{128.5 + 187}{2(126)} = 1.25$$

$$\psi(\text{bottom}) = 0$$

From the chart (Fig. 12.3),  $K$  is 1.2 for an unbraced frame.

$$\frac{Kl_u}{r} = \frac{1.2(16 \times 12)}{0.3 \times 18} = 42.7 > 22$$

which is more than 22. Therefore, the slenderness effect must be considered.

4. Compute  $P_c$ :

$$E_c = 4.03 \times 10^3 \text{ ksi} \quad E_s = 29 \times 10^3 \text{ ksi}$$

$$I_g = 8748 \text{ in.}^4 \quad I_{se} = 4 \times 1.27 \left( \frac{18 - 5}{2} \right)^2 = 214 \text{ in.}^4$$

Assume  $\beta_{ds} = 0$  (no shear, ACI 10.10.4.2)

$$\begin{aligned} EI &= \frac{0.2E_cI_g + E_sI_{se}}{1 + \beta_{ds}} \\ &= \frac{0.2(4.03 \times 10^3 \times 8748) + 29 \times 10^3(214)}{1 + 0.9} = 13.25 \times 10^6 \text{ K} \cdot \text{in.}^2 \end{aligned}$$

$$P_c = \frac{\pi^2(13.25 \times 10^6)}{(1.2 \times 16 \times 12)^2} = 2461.11 \text{ K (unbraced)}$$

Analyze 18 exterior columns along lines 1 and 4 with one beam framing into them in the direction of analysis.

$$\psi(\text{top}) = \frac{128.5 + 187}{126} = 2.5$$

$$\psi(\text{bottom}) = 0$$

From the chart (Fig. 12.3)  $K = 1.3$ :

$$\frac{Kl_u}{r} = \frac{1.3(16 \times 12)}{0.3(18)} = 46.2 > 22$$

Therefore, the slenderness effect must be considered.

Compute  $P_c$ :

$$P_c = \frac{\pi^2 EI}{(Kl_u)^2} = \frac{\pi^2(13.25 \times 10^6)}{(1.3 \times 16 \times 12)^2} = 2097 \text{ K}$$

5. Calculate moment magnifier for gravity load and wind load:

For one floor in the building, there are 14 interior columns, 18 exterior columns, and four corner columns.

$$\sum P_u = 14(460) + 18\left(\frac{2}{3} \times 460\right) + 4\left(\frac{1}{3} \times 460\right) = 12,573 \text{ K}$$

$$\sum P_c = 18(2461) + 18(2097) = 82046 \text{ K}$$

$$\delta_s = \frac{1.0}{1 - 12,573/(0.75 \times 82046)} = 1.26 \geq 1.0$$

which is greater than 1.0 (Eq. 12.17).

6. Calculate the design magnified moment

$$M_c = M_{u,\text{bns}} + \delta_s M_{u,\text{bs}} = (100.8) + 1.26(80) = 201.34 \text{ K} \cdot \text{ft}$$

7. Design loads are  $P_u = 460 \text{ K}$  and  $M_c = 201.34 \text{ K} \cdot \text{ft}$ .

$$e = \frac{201.34(12)}{460} = 5.25 \text{ in.}$$

$$e_{\min} = 0.6 + 0.03(18) = 1.14 \text{ in.} < e$$

By analysis, for  $e = 5.25 \text{ in.}$  and  $A_s = A'_s = 2.53 \text{ in.}^2$ , ( $\phi = 0.65 \text{ in.}$ ), the load capacity of the  $18 \times 18$ -in. column is  $\phi P_n = 556 \text{ K}$  and  $\phi M_n = 259 \text{ K} \cdot \text{ft}$ , so the section is adequate. (Solution steps are similar to Example 11.4. Values are  $a = 10.37 \text{ in.}$ ,  $c = 13 \text{ in.}$ ,  $f_s = 17 \text{ ksi}$ ,  $f'_s = 60 \text{ ksi}$ ,  $\phi P_b = 385 \text{ K}$ , and  $e_b = 8.9 \text{ in.}$ ).

$$\epsilon_t = 0.003 \frac{15.5 - 13}{13} = 0.00058 < 0.002 \quad \phi = 0.65.$$

## SUMMARY

### Sections 12.1–12.3

1. The radius of gyration is  $r = \sqrt{I/A}$ , where  $r = 0.3h$  for rectangular sections and  $0.25D$  for circular sections.
2. The effective column length is  $Kl_u$ . For braced frames,  $K = 1.0$ ; for unbraced frames,  $K$  varies as shown in Fig. 12.2.

3. The value of  $K$  can be determined from the alignment chart (Fig. 12.3) or Eqs. 12.2 through 12.6.

### Section 12.4

Member stiffness is  $EI$ :

$$E_c = 33w^{1.5}\sqrt{f'_c}$$

The moment of inertia,  $I$ , may be taken as  $I=0.35I_g$  for beams,  $0.70I_g$  for columns,  $0.70I_g$  for uncracked walls,  $0.35I_g$  for cracked walls, and  $0.25I_g$  for plates and flat slabs.

Alternatively, the moments of inertia of compression and flexural members,  $I$ , shall be permitted to be computed as follows:

1. Compression members:

$$I = \left(0.80 + 25\frac{A_{st}}{A_g}\right) \left(1 - \frac{M_u}{P_u h} - 0.5\frac{P_u}{P_o}\right) I_g \leq 0.875I_g \quad (\text{Eq.12.2})$$

2. Flexural members:

$$I = (0.10 + 25\rho) \left(1.2 - 0.2\frac{b_w}{d}\right) I_g \leq 0.5I_g \quad (\text{Eq.12.3})$$

### Section 12.5

The effect of slenderness may be neglected when

$$\frac{Kl_u}{r} \leq \begin{cases} 22 & (\text{for unbraced frames}) \\ 34 - 12\frac{M_1}{M_2} \leq 40 & (\text{for braced columns}) \end{cases} \quad (\text{Eq.12.8})$$

$$(\text{Eq.12.5})$$

where  $M_1$  and  $M_2$  are the end moments and  $M_2 > M_1$ .

### Section 12.6

1. For nonsway frames,

$$EI = \frac{0.2E_c I_g + E_s I_{se}}{1 + \beta_{dns}} \quad (\text{Eq.12.10})$$

or the more simplified equation

$$EI = \frac{0.4E_c I_g}{1 + \beta_{dns}} \quad (\text{Eq.12.11})$$

$$\beta_{dns} = \frac{1.2D}{1.2D + 1.6L} \quad (\text{Eq.12.4})$$

More simply,

$$EI = 0.25E_c I_g (\beta_{dns} = 0.6) \quad (\text{Eq.12.12})$$

The Euler buckling load is

$$P_c = \frac{\pi^2 EI}{(Kl_u)^2} \quad (\text{Eq.12.13})$$

$$C_m = 0.6 + \frac{0.4M_1}{M_2} \quad (\text{Eq.12.14})$$

The moment-magnifier factor (nonsway frames) is

$$\delta_{\text{ns}} = \frac{C_m}{1 - (P_u/0.75P_c)} \quad (\text{Eq.12.15})$$

The design moment is

$$M_c = \delta_{\text{ns}}M_2 \quad (\text{Eq.12.16})$$

2. For sway (unbraced) frames, the moment-magnifier factor is calculated either from

a. Magnifier method:

$$\delta_s = \frac{1.0}{1 - (\sum P_u/0.75 \sum P_c)} \geq 1.0 \quad (\text{Eq.12.17})$$

b. Approximate second-order analysis:

$$\delta_s = \frac{1}{1 - Q} \quad (\text{Eq.12.19})$$

$$Q = \frac{\sum P_u \Delta_0}{V_{us} l_c} \quad (\text{Eq.12.20})$$

the design moment is

$$M_1 = M_{1\text{ns}} + \delta_s M_{1s} \quad (\text{Eq.12.21})$$

$$M_2 = M_{2\text{ns}} + \delta_s M_{2s} \quad (\text{Eq.12.22})$$

where  $M_{2\text{ns}}$  is the unmagnified moment due to gravity loads (nonsway moment) and  $\delta_s M_{2s}$  is the magnified moment due to sway frame loads.

$$M_c = \text{larger of } M_1 \text{ and } M_2 \quad (\text{Eq.12.23})$$

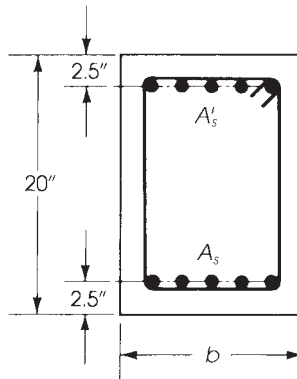
## REFERENCES

1. B. B. Broms. "Design of Long Reinforced Concrete Columns." *Journal of Structural Division ASCE* 84 (July 1958).
2. J. G. MacGregor, J. Breen, and E. O. Pfrang. "Design of Slender Concrete Columns." *ACI Journal* 67 (January 1970).
3. American Concrete Institute (ACI). *The Reinforced Concrete Design Manual*, vol. 1, ACI Publication SP-17(11). ACI, Detroit, MI, 2011.
4. W. F. Chang and P. M. Ferguson. "Long Hinged Reinforced Concrete Column." *ACI Journal* 60 (January 1963).
5. R. W. Furlong and P. M. Ferguson. "Tests of Frames with Columns in Single Curvature." ACI Publication SP-13. Paper presented at the Symposium on Reinforced Columns. American Concrete Institute, Detroit, MI, 1966.
6. J. G. MacGregor and S. L. Barter. *Long Eccentrically Loaded Concrete Columns Bent in Double Curvature*. ACI Publication SP-13. Paper presented at the Symposium on Reinforced Concrete Columns. American Concrete Institute, Detroit, MI, 1966.

7. R. Green and J. E. Breen. "Eccentrically Loaded Concrete Columns Under Sustained Load." *ACI Journal* 66 (November 1969).
8. B. G. Johnston. *Guide to Stability Design for Metal Structures*, 3rd ed. Wiley, New York, 1976.
9. T. C. Kavanaugh. "Effective Length of Frames Columns." *Transactions ASCE* 127, Part II (1962).
10. American Concrete Institute (ACI). *Commentary on Building Code Requirements for Reinforced Concrete*. ACI 318-14. ACI, Detroit, MI, 2014.
11. R. G. Drysdale and M. W. Huggins. "Sustained Biaxial Load on Slender Concrete Columns." *Journal of Structural Division ASCE* 97 (May 1971).
12. American Concrete Institute (ACI). *Building Code Requirements for Structural Concrete*. ACI 318-99. ACI, Detroit, MI, 1999.
13. J. G. MacGregor. "Design of Slender Concrete Column." *ACI Structural Journal* 90, no. 3 (May–June 1993).
14. J. S. Grossman. "Reinforced Concrete Design." *Building Structural Design Handbook*. Wiley, New York, 1987, Chapter 22.

## PROBLEMS

- 12.1** The column section in Fig. 12.8 carries an axial load  $P_D = 128$  K and a moment  $M_D = 117$  K · ft due to dead load and an axial load  $P_L = 95$  K and a moment  $M_1 = 100$  K · ft due to live load. The column is part of a frame, braced against sidesway, and bent in single curvature about its major axis. The unsupported length of the column is  $l_u = 18$  ft, and the moments at both ends are equal. Check the adequacy of the section using  $f'_c = 4$  ksi and  $f_y = 60$  ksi.



**Figure 12.8** Problem 12.1. ( $A_s = A'_s = 5$ ) no. 9 bars and  $b = 14$  in.

- 12.2** Repeat Problem 12.1 if  $l_u = 12$  ft.
- 12.3** Repeat Problem 12.1 if the frame is unbraced against sidesway and the end-restraint factors are  $\psi$  (top) = 0.7 and  $\psi$  (bottom) = 1.8 and the unsupported height is  $l_u = 14$  ft.
- 12.4** The column section shown in Fig. 12.9 is part of a frame unbraced against sidesway and supports an axial load  $P_D = 166$  K and a moment  $M_D = 107$  K · ft due to dead load and  $P_L = 115$  K and  $M_L = 80$  K · ft due to live load. The column is bent in single curvature and has an unsupported length  $l_u = 16$  ft. The moment at the top of the column is  $M_2 = 1.5M_1$ , the moment at the bottom of the column. Check if the section is adequate using  $f'_c = 5$  ksi,  $f_y = 60$  ksi,  $\psi$  (top) = 2.0, and  $\psi$  (bottom) = 1.0.

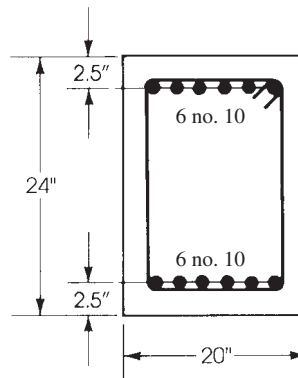


Figure 12.9 Problem 12.4.

- 12.5** Repeat Problem 12.4 if the column length is  $l_u = 14$  ft.
- 12.6** Repeat Problem 12.4 if the frame is braced against sidesway and  $M_1 = M_2$ .
- 12.7** Repeat Problem 12.4 using  $f'_c = 4$  ksi and  $f_y = 60$  ksi.
- 12.8** Design a 20-ft-long rectangular tied column for an axial load  $P_D = 214.5$  K and a moment  $M_D = 64$  K · ft due to dead load and an axial load  $P_L = 120$  K and a moment  $M_L = 40$  K · ft due to live load. The column is bent in single curvature about its major axis, braced against sidesway, and the end moments are equal. The end-restraint factors are  $\psi$  (top) = 2.5 and  $\psi$  (bottom) = 1.4. Use  $f'_c = 5$  ksi,  $f_y = 60$  ksi, and  $b = 15$  in.
- 12.9** Design the column in Problem 12.8 if the column length is 10 ft.
- 12.10** Repeat Problem 12.8 if the column is unbraced against sidesway.

# CHAPTER 13

## FOOTINGS



Office building under construction, New Orleans, Louisiana.

### 13.1 INTRODUCTION

Reinforced concrete footings are structural members used to support columns and walls and to transmit and distribute their loads to the soil. The design is based on the assumption that the footing is rigid, so that the variation of the soil pressure under the footing is linear. Uniform soil pressure is achieved when the column load coincides with the centroid of the footing. Although this assumption is acceptable for rigid footings, such an assumption becomes less accurate as the footing becomes relatively more flexible. The proper design of footings requires that

1. The load capacity of the soil is not exceeded.
2. Excessive settlement, differential settlement, or rotations are avoided.
3. Adequate safety against sliding and/or overturning is maintained.

The most common types of footings used in buildings are the single footings and wall footings (Figs. 13.1 and 13.2). When a column load is transmitted to the soil by the footing, the soil becomes compressed. The amount of settlement depends on many factors, such as the type of soil, the load intensity, the depth below ground level, and the type of footing. If different footings of the same structure have different settlements, new stresses develop in the structure. Excessive differential settlement may lead to the damage of nonstructural members in the buildings or even failure of the affected parts.

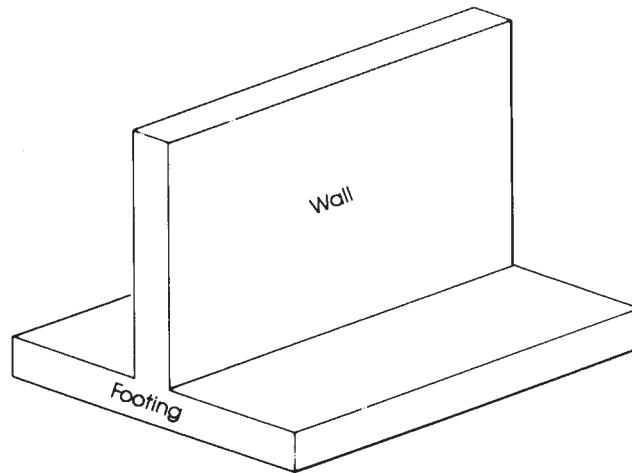


Figure 13.1 Wall footing.

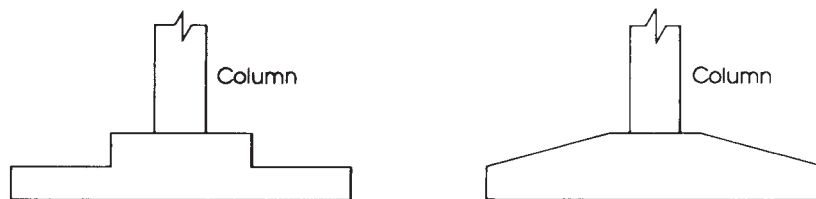
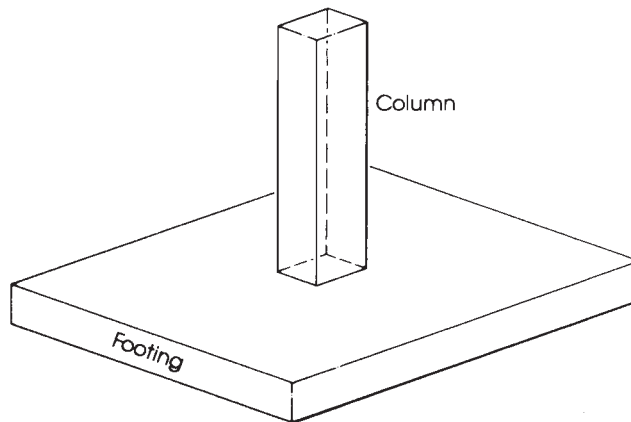


Figure 13.2 Single footing.



Vertical loads are usually applied at the centroid of the footing. If the resultant of the applied loads does not coincide with the centroid of the bearing area, a bending moment develops. In this case, the pressure on one side of the footing will be greater than the pressure on the other side.

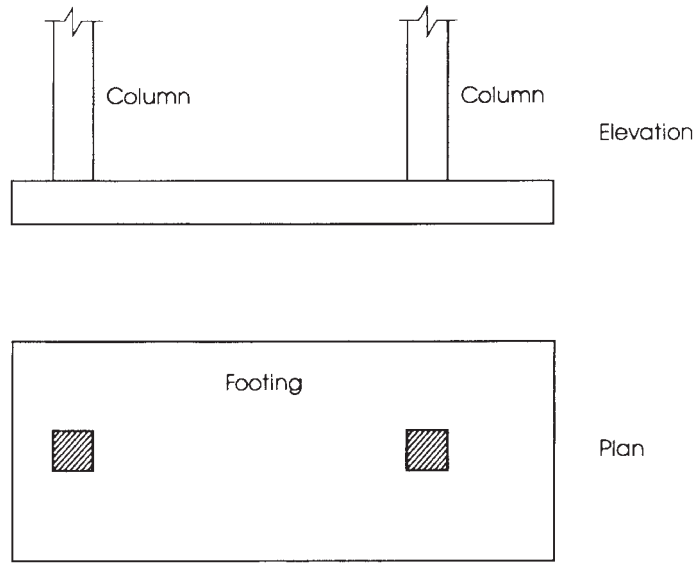
If the bearing soil capacity is different under different footings—for example, if the footings of a building are partly on soil and partly on rock—a differential settlement will occur. It is usual in such cases to provide a joint between the two parts to separate them, allowing for independent settlement.

The depth of the footing below the ground level is an important factor in the design of footings. This depth should be determined from soil tests, which should provide reliable information on safe bearing capacity at different layers below ground level. Soil test reports specify the allowable bearing capacity to be used in the design. In cold areas where freezing occurs, frost action may cause heaving or subsidence. It is necessary to place footings below freezing depth to avoid movements.

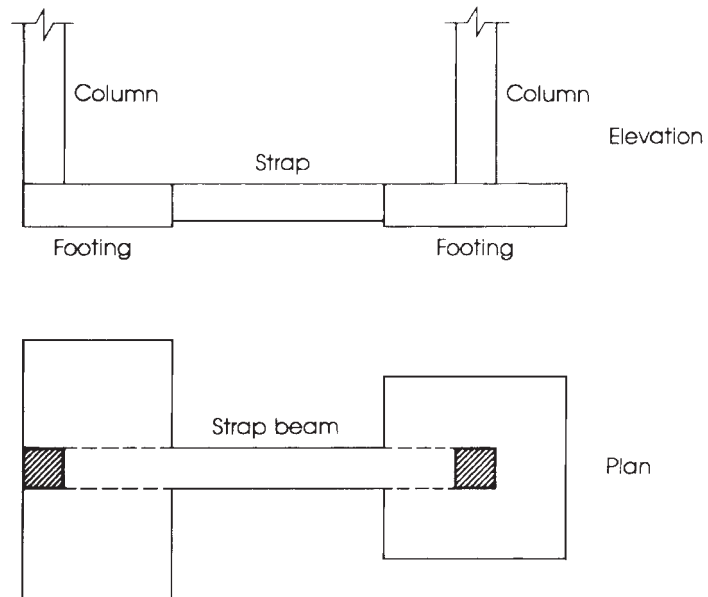
## 13.2 TYPES OF FOOTINGS

Different types of footings may be used to support building columns or walls. The most common types are as follows:

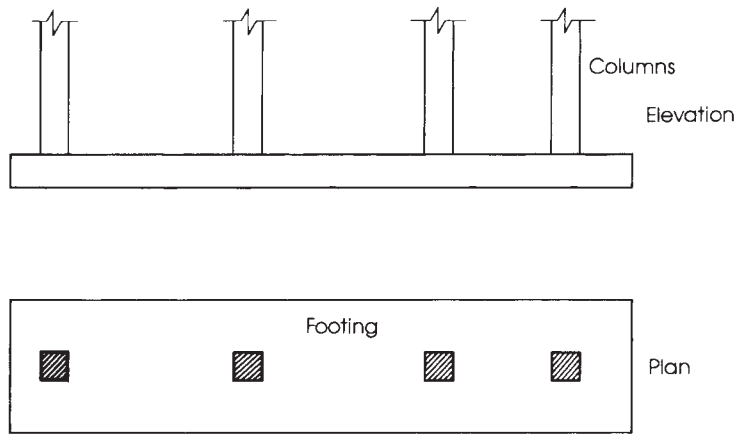
1. *Wall footings* are used to support structural walls that carry loads from other floors or to support nonstructural walls. They have a limited width and a continuous length under the wall (Fig. 13.1). Wall footings may have one thickness, be stepped, or have a sloped top.
2. *Isolated, or single, footings* are used to support single columns (Fig. 13.2). They may be square, rectangular, or circular. Again, the footing may be of uniform thickness, stepped, or have a sloped top. This is one of the most economical types of footings, and it is used when columns are spaced at relatively long distances. The most commonly used are square or rectangular footings with uniform thickness.
3. *Combined footings* (Fig. 13.3) usually support two columns or three columns even if not in a row. The shape of the footing in the plan may be rectangular or trapezoidal, depending on column loads. Combined footings are used when two columns are so close that single footings cannot be used or when one column is located at or near a property line.
4. *Cantilever, or strap, footings* (Fig. 13.4) consist of two single footings connected with a beam or a strap and support two single columns. They are used when one footing supports an eccentric column and the nearest adjacent footing lies at quite a distance from it. This type replaces a combined footing and is sometimes more economical.
5. *Continuous footings* (Fig. 13.5) support a row of three or more columns. They have limited width and continue under all columns.
6. *Raft, or mat, foundations* (Fig. 13.6) consist of one footing, usually placed under the entire building area, and support the columns of the building. They are used when
  - a. The soil-bearing capacity is low.
  - b. Column loads are heavy.
  - c. Single footings cannot be used.
  - d. Piles are not used.
  - e. Differential settlement must be reduced through the entire footing system.
7. *Pile caps* (Fig. 13.7) are thick slabs used to tie a group of piles together and to support and transmit column loads to the piles.



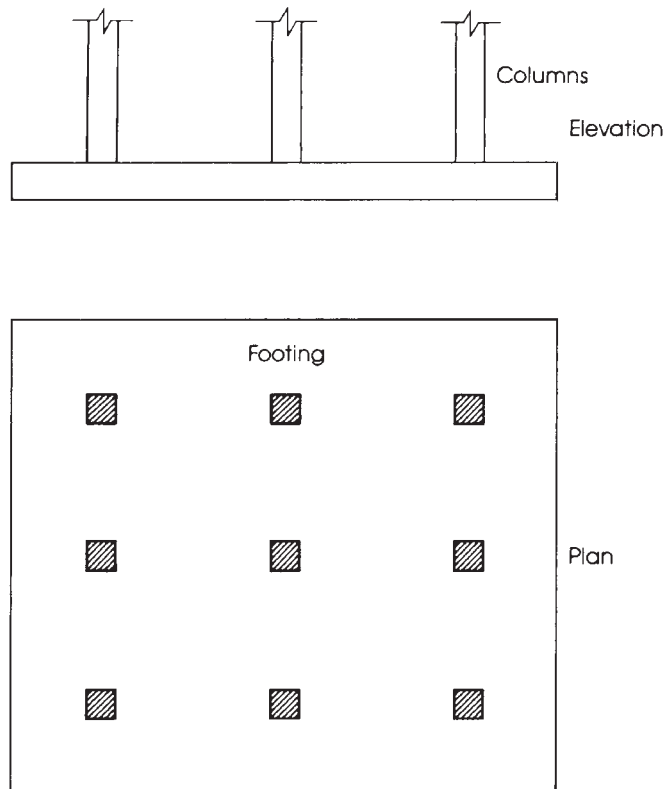
**Figure 13.3** Combined footing.



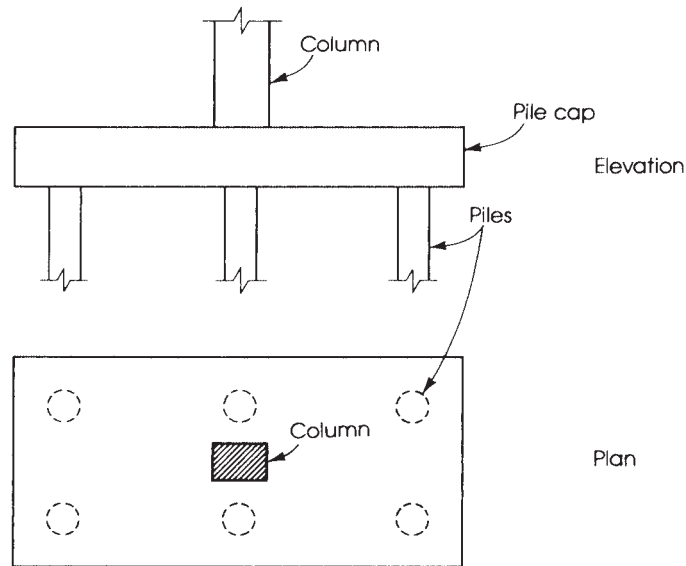
**Figure 13.4** Strap footing.



**Figure 13.5** Continuous footing.



**Figure 13.6** Raft, or mat, foundation.

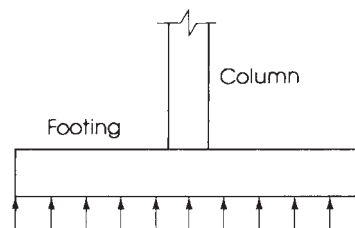


**Figure 13.7** Pile cap footing.

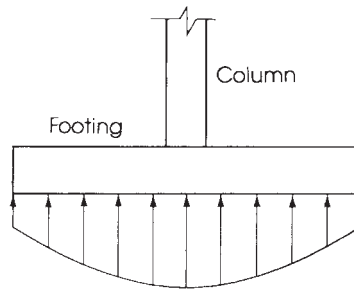
### 13.3 DISTRIBUTION OF SOIL PRESSURE

Figure 13.8 shows a footing supporting a single column. When the column load,  $P$ , is applied on the centroid of the footing, a uniform pressure is assumed to develop on the soil surface below the footing area. However, the actual distribution of soil pressure is not uniform but depends on many factors, especially the composition of the soil and the degree of flexibility of the footing.

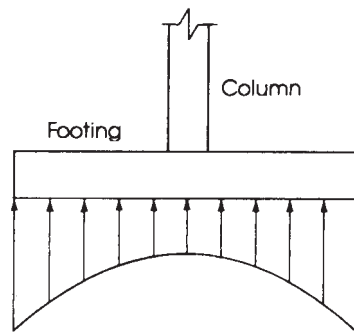
For example, the distribution of pressure on cohesionless soil (sand) under a rigid footing is shown in Fig. 13.9. The pressure is at maximum under the center of the footing and decreases toward the ends of the footing. The cohesionless soil tends to move from the edges of the footing, causing a reduction in pressure, whereas the pressure increases around the center to satisfy equilibrium conditions. If the footing is resting on a cohesive soil such as clay, the pressure under the edges is greater than at the center of the footing (Fig. 13.10). The clay near the edges has a strong cohesion with the adjacent clay surrounding the footing, causing the nonuniform pressure distribution.



**Figure 13.8** Distribution of soil pressure assuming uniform pressure.



**Figure 13.9** Soil pressure distribution in cohesionless soil (sand).



**Figure 13.10** Soil pressure distribution in cohesive soil (clay).

The allowable bearing soil pressure,  $q_a$ , is usually determined from soil tests. The allowable values vary with the type of soil, from extremely high in rocky beds to low in silty soils. For example,  $q_a$  for sedimentary rock is 30 ksf, for compacted gravel is 8 ksf, for well-graded compacted sand is 6 ksf, and for silty-gravel soils is 3 ksf.

Referring to Fig. 13.8, when the load  $P$  is applied, the part of the footing below the column tends to settle downward. The footing will tend to take a uniform curved shape, causing an upward pressure on the projected parts of the footing. Each part acts as a cantilever and must be designed for both bending moments and shearing forces. The design of footings is explained in detail later.

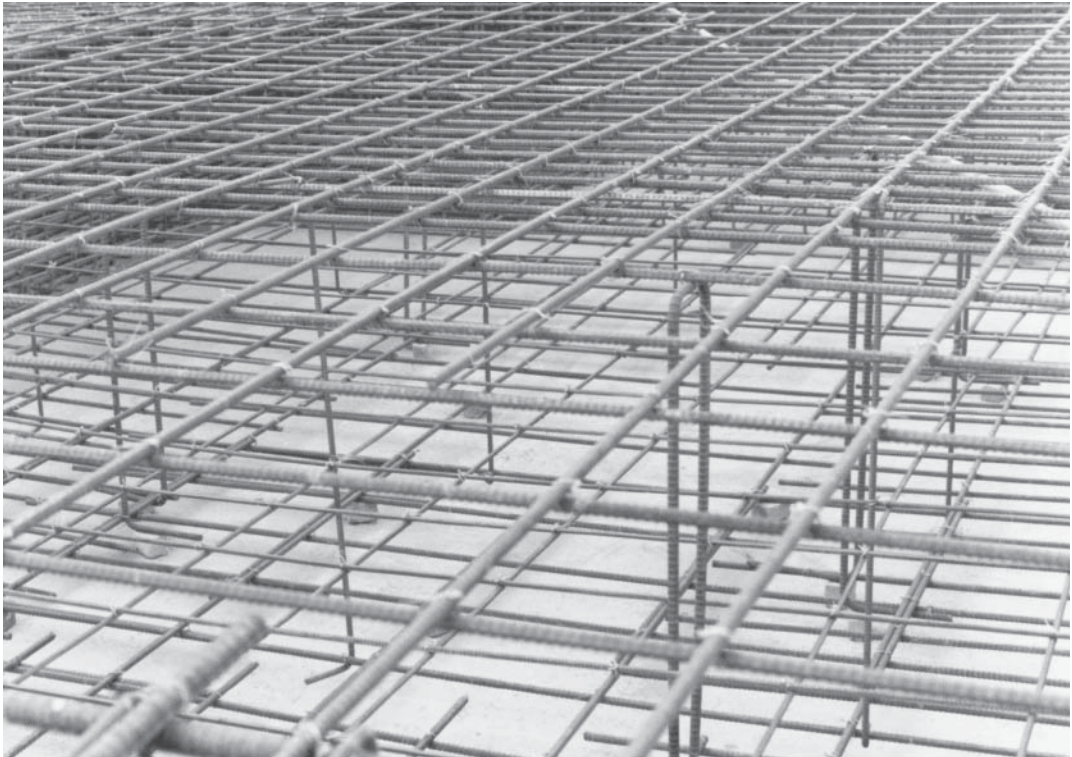
### 13.4 DESIGN CONSIDERATIONS

Footings must be designed to carry the column loads and transmit them to the soil safely. The design procedure must take the following strength requirements into consideration:

1. The area of the footing based on the allowable bearing soil capacity.
2. One-way shear.
3. Two-way shear, or punching shear.

4. Bending moment and steel reinforcement required.
5. Bearing capacity of columns at their base and dowel requirements.
6. Development length of bars.
7. Differential settlement.

These strength requirements are explained in the following sections.



Reinforcing rebars placed in tow layers in a raft foundation.

### 13.4.1 Size of Footings

The area of the footings can be determined from the actual external loads (unfactored forces and moments) such that the allowable soil pressure is not exceeded. In general, for vertical loads

$$\text{Area of footing} = \frac{\text{total service load (including self - weight)}}{\text{allowable soil pressure, } q_a} \quad (13.1)$$

or

$$\text{Area} = \frac{P(\text{total})}{q_a}$$

where the total service load is the unfactored design load. Once the area is determined, a factored soil pressure is obtained by dividing the factored load,  $P_u = 1.2D + 1.6L$ , by the area of the footing.

This is required to design the footing by the strength design method.

$$q_u = \frac{P_u}{\text{area of footing}} \quad (13.2)$$

The allowable soil pressure,  $q_a$ , is obtained from soil test and is based on service load conditions.

### 13.4.2 One-Way Shear (Beam Shear) ( $V_{u1}$ )

For footings with bending action in one direction, the critical section is located at a distance  $d$  from the face of the column. The diagonal tension at section  $m-m$  in Fig. 13.11 can be checked as was done before in beams. The allowable shear in this case is equal to

$$\phi V_c = 2\phi\lambda\sqrt{f'_c}bd \quad (\phi = 0.75) \quad (13.3)$$

where  $b$  is the width of section  $m-m$ . The factored shearing force at section  $m-m$  can be calculated as follows:

$$V_{u1} = q_u b \left( \frac{L}{2} - \frac{c}{2} - d \right) \quad (13.4)$$

If no shear reinforcement is to be used, then  $d$  can be determined, assuming  $V_u = \phi V_c$ :

$$d = \frac{V_{u1}}{2\phi\lambda\sqrt{f'_c}b} \quad (13.5)$$



Wall and column footings, partly covered.

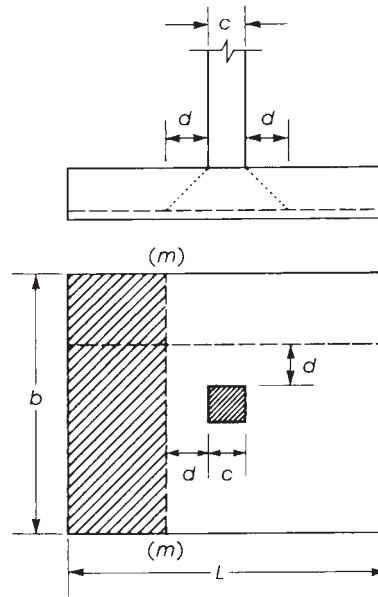


Figure 13.11 One-way shear.

### 13.4.3 Two-Way Shear (Punching Shear) ( $V_{u2}$ )

Two-way shear is a measure of the diagonal tension caused by the effect of the column load on the footing. Inclined cracks may occur in the footing at a distance  $d/2$  from the face of the column on all sides. The footing will fail as the column tries to punch out part of the footing (Fig. 13.12).

The ACI Code, Section 22.6.5.2, allows a shear strength,  $V_c$ , in footings without shear reinforcement for two-way shear action, the smallest of

$$V_{c1} = 4\lambda\sqrt{f'_c}b_0d \quad (13.6)$$

$$V_{c2} = \left(2 + \frac{4}{\beta}\right)\lambda\sqrt{f'_c}b_0d \quad (13.7)$$

$$V_{c3} = \left(\frac{\alpha_s d}{b_0} + 2\right)\lambda\sqrt{f'_c}b_0d \quad (13.8)$$

where

$\beta$  = ratio of long side to short side of column

$b_0$  = perimeter of critical section taken at  $d/2$  from loaded area (column section) (see Fig. 13.12)

$d$  = effective depth of footing

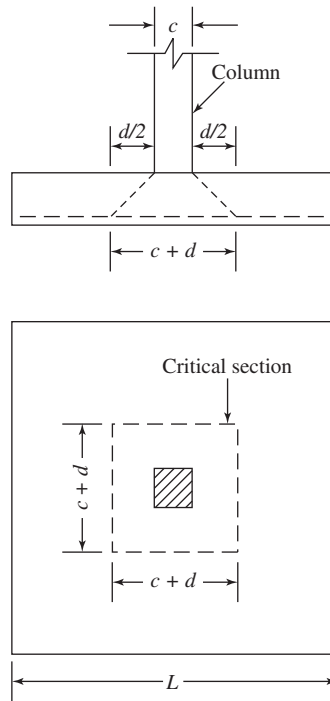
$\lambda$  = modification factor for type of concrete (ACI Code, Section 8.6.1)

$\lambda = 1.0$  for normal-weight concrete

$\lambda = 0.85$  for sand-lightweight concrete

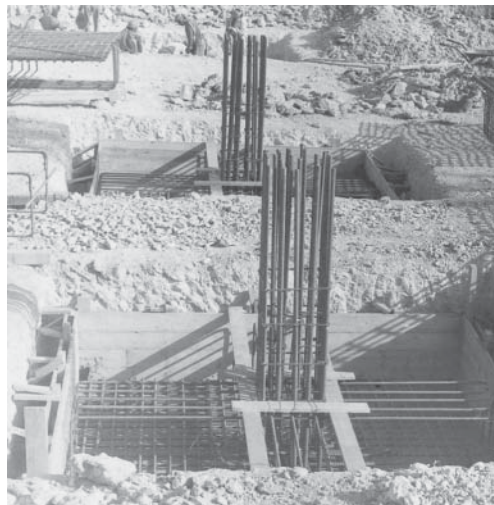
$\lambda = 0.75$  for all-lightweight concrete





**Figure 13.12** Punching shear (two way).

Linear interpolation shall be permitted between 0.85 and 1.0 on the basis of volumetric fractions, for concrete containing normal-weight fine aggregate and a blend of lightweight and normal-weight coarse aggregate. Linear interpolation between 0.75 and 0.85 shall be permitted, on the basis of volumetric fractions, when a portion of the lightweight fine aggregate is replaced with normal-weight fine aggregate.



Reinforced concrete single footings.

For the values of  $V_{c_1}$  and  $V_{c_2}$  it can be observed that  $V_{c_1}$  controls (less than  $V_{c_2}$ ) whenever  $\beta_c \leq 2$ , whereas  $V_{c_2}$  controls (less than  $V_{c_1}$ ) whenever  $\beta_c > 2$ . This indicates that the allowable shear  $V_c$  is reduced for relatively long footings. The actual soil pressure variation along the long side increases with an increase in  $\beta$ . For shapes other than rectangular,  $\beta$  is taken to be the ratio of the longest dimension of the effective loaded area in the long direction to the largest width in the short direction (perpendicular to the long direction).

For Eq. 13.8,  $\alpha_s$  is assumed to be 40 for interior columns, 30 for edge columns, and 20 for corner columns. The concrete shear strength  $V_{c_3}$  represents the effect of an increase in  $b_0$  relative to  $d$ . For a high ratio of  $b_0/d$ ,  $V_{c_3}$  may control.

Based on the preceding three values of  $V_c$ , the effective depth,  $d$ , required for two-way shear is the largest obtained from the following formulas ( $\phi = 0.75$ ):

$$d_1 = \frac{V_{u_2}}{\phi 4 \lambda \sqrt{f'_c} b_0} \quad (\text{where } \beta \leq 2) \quad (13.9)$$

or

$$d_1 = \frac{V_{u_2}}{\phi (2 + 4/\beta) \lambda \sqrt{f'_c} b_0} \quad (\text{where } \beta > 2) \quad (13.10)$$

$$d_2 = \frac{V_{u_2}}{\phi (\alpha_s d/b_0 + 2) \lambda \sqrt{f'_c} b_0} \quad (13.11)$$

The two-way shearing force,  $V_{u_2}$ , and the effective depth,  $d$ , required (if shear reinforcement is not provided) can be calculated as follows (refer to Fig. 13.12):

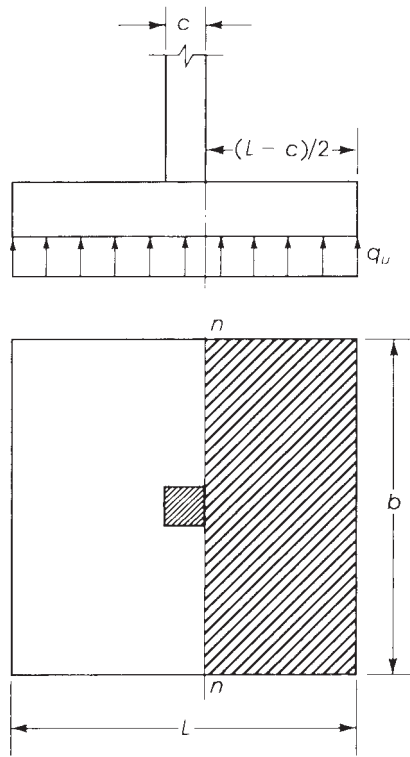
1. Assume  $d$ .
2. Determine  $b_0$ :  $b_0 = 4(c + d)$  for square columns, where one side =  $c$ .  $b_0 = 2(c_1 + d) + 2(c_2 + d)$  for rectangular columns of sides  $c_1$  and  $c_2$ .
3. The shearing force  $V_{u_2}$  acts at a section that has a length  $b_0 = 4(c + d)$  or  $[2(c_1 + d) + 2(c_2 + d)]$  and a depth  $d$ ; the section is subjected to a vertical downward load,  $P_u$ , and a vertical upward pressure,  $q_u$  (Eq. 13.2). Therefore,

$$V_{u_2} = \begin{cases} P_u - q_u(c + d)^2 & \text{for square columns} & (13.12a) \\ P_u - q_u(c_1 + d)(c_2 + d) & \text{for rectangular columns} & (13.12b) \end{cases}$$

4. Determine the largest  $d$  (of  $d_1$  and  $d_2$ ). If  $d$  is not close to the assumed  $d$ , revise your assumption and repeat. ACI Code, Sections 13.3.1.2 and 13.4.2.1 specifies depth of footing above bottom reinforcement shall not be less than 6 in. for footing on soil, nor less than 12 in. for footing on piles.

#### 13.4.4 Flexural Strength and Footing Reinforcement

The critical sections for moment occur at the face of the column (section  $n-n$ , Fig. 13.13). The bending moment in each direction of the footing must be checked and the appropriate reinforcement must be provided. In square footings and square columns, the bending moments in both directions are equal. To determine the reinforcement required, the depth of the footing in each direction may be used. Because the bars in one direction rest on top of the bars in the other direction, the effective depth,  $d$ , varies with the diameter of the bars used. An average value of  $d$  may be adopted. A practical value of  $d$  may be assumed to be  $h - 4.5$  in.



**Figure 13.13** Critical section of bending moment.

The depth of the footing is often controlled by shear, which requires a depth greater than that required by the bending moment. The steel reinforcement in each direction can be calculated in the case of flexural members as follows:

$$M_u = \phi A_s f_y \left( d - \frac{A_s f_y}{1.7 f'_c b} \right) \quad (13.13)$$

Also, the steel ratio,  $\rho$ , can be determined as follows (Eq. 4.2a):

$$\rho = \frac{0.85 f'_c}{f_y} \left[ 1 - \sqrt{1 - \frac{2R_u}{\phi (0.85 f'_c)}} \right] \quad (13.14)$$

where  $R_u$  equals  $M_u/bd^2$ . When  $R_u$  is determined,  $\rho$  can also be obtained from Eq. 13.15.

The minimum steel ratio requirement in flexural members is equal to  $200/f_y$  when  $f'_c < 4500$  psi and equal to  $3\sqrt{f'_c}/f_y$  when  $f'_c \geq 4500$  psi. However, the ACI Code, Section 9.6.1, indicates that for structural slabs of uniform thickness, the minimum area and maximum spacing of steel bars in the direction of bending shall be as required for shrinkage and temperature reinforcement. This last minimum steel requirement is very small, and a higher minimum reinforcement ratio is recommended, but it should not be greater than  $200/f_y$ .

The reinforcement in one-way footings and two-way footings must be distributed across the entire width of the footing. In the case of two-way rectangular footings, the ACI Code, Section 13.3.3.3, specifies reinforcement in the long direction shall be distributed uniformly across

the entire width of the footing. For reinforcement in the short direction a portion of the total reinforcement,  $\gamma_s A_s$ , shall be distributed uniformly over a bandwidth (centered on the centerline of the column or pedestal) equal to the length of the short side of the footing. The remainder of  $1 - \gamma_s$  as reinforcement is required to distribute uniformly the outside center band width of the footing:

$$\gamma_s = \frac{2}{\beta + 1} \quad (13.15)$$

where

$$\beta = \frac{\text{long side of footing}}{\text{short side of footing}} \quad (13.16)$$

The bandwidth must be centered on the centerline of the column (Fig. 13.14). The remaining reinforcement in the short direction must be uniformly distributed outside the bandwidth. This remaining reinforcement percentage shall not be less than that required for shrinkage and temperature.

When structural steel columns or masonry walls are used, then the critical sections for moments in footings are taken at halfway between the middle and the edge of masonry walls and halfway between the face of the column and the edge of the steel base plate (ACI Code, Section 13.2.7.1).

### 13.4.5 Bearing Capacity of Column at Base

The loads from the column act on the footing at the base of the column, on an area equal to the area of the column cross section. Compressive forces are transferred to the footing directly by bearing on the concrete.

Forces acting on the concrete at the base of the column must not exceed the bearing strength of concrete as specified by the ACI Code, Section 22.8.3.2:

$$\text{Bearing strength } N_1 = \phi(0.85f'_c A_1) \quad (13.17)$$

where  $\phi$  is 0.65 and  $A_1$  is the bearing area of the column. The value of the bearing strength given in Eq. 13.17 may be multiplied by a factor  $\sqrt{A_2/A_1} \leq 2.0$  for bearing on footings when the supporting surface is wider on all sides than the loaded area. Here  $A_2$  is the area of the part of the supporting footing that is geometrically similar to and concentric with the loaded area (Figs. 13.15 and 13.16). Because  $A_2 > A_1$ , the factor  $\sqrt{A_2/A_1}$  is greater than unity, indicating that the allowable bearing

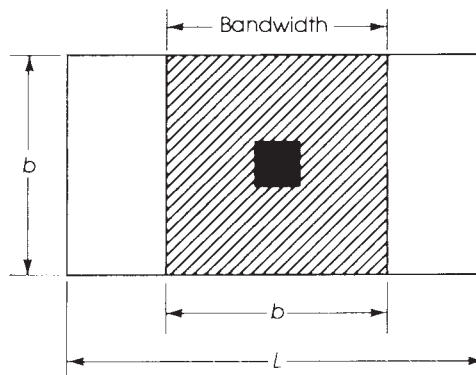
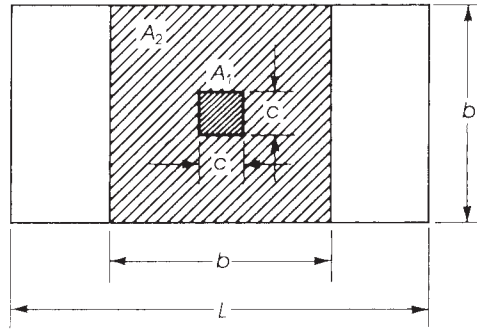
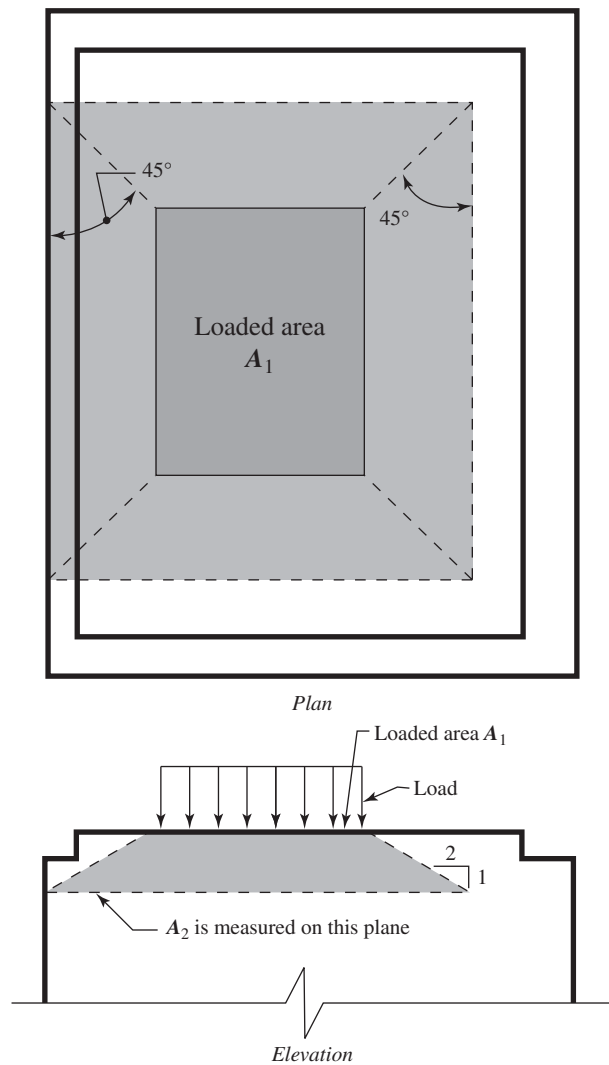


Figure 13.14 Bandwidth for reinforcement distribution.



**Figure 13.15** Bearing areas on footings.  $A_1 = c^2$ ,  $A_2 = b^2$ .



**Figure 13.16** Area of bearing stress. Courtesy of ACI

strength is increased because of the lateral support from the footing area surrounding the column base. The modified bearing strength is

$$N_2 = \phi(0.85f'_cA_1)\sqrt{\frac{A_2}{A_1}} \leq 2\phi(0.85f'_cA_1) \quad (13.18)$$

If the factored force,  $P_u$ , is greater than either  $N_1$  or  $N_2$  reinforcement must be provided to transfer the excess force. This is achieved by providing dowels or extending the column bars into the footing. The excess force is  $P_{ex} = P_u - N_1$  and the area of the dowel bars is  $A_{sd} = (P_{ex}/f_y) \geq 0.005 A_1$ , where  $A_1$  is the area of the column section. At least four bars should be used at the four corners of the column. If the factored force is less than either  $N_1$  or  $N_2$ , then minimum reinforcement must be provided. The ACI Code, Section 16.3.5.1, indicates that the minimum area of the dowel reinforcement is at least  $0.005A_g$  (and not less than four bars), where  $A_g$  is the gross area of the column section. The minimum reinforcement requirements apply also to the case when the factored forces are greater than  $N_1$  and  $N_2$ . The dowel bars may be placed at the four corners of the column and extended in both the column and footing. The dowel diameter shall not exceed the diameter of the longitudinal bars in the columns by more than 0.15 in. This requirement is necessary to ensure proper action between the column and footing. The development length of the dowels must be checked to determine proper transfer of the compression force into the footing.

#### 13.4.6 Development Length of the Reinforcing Bars

The critical sections for checking the development length of the reinforcing bars are the same as those for bending moments. The development length for compression bars was given in Chapter 7:

$$l_{dc} = \frac{0.02f_yd_b}{\lambda\sqrt{f'_c}} \quad (\text{Eq. 7.14})$$

but this value cannot be less than  $0.0003 f_y d_b \geq 8$  in. For other values, refer to Chapter 7.

#### 13.4.7 Differential Settlement (Balanced Footing Design)

Footings usually support the following loads:

- Dead loads from the substructure and superstructure.
- Live load resulting from occupancy.
- Weight of materials used in backfilling.
- Wind loads.

Each footing in a building is designed to support the maximum load that may occur on any column due to the critical combination of loadings, using the allowable soil pressure.

The dead load, and maybe a small portion of the live load (called the *usual* live load), may act continuously on the structure. The rest of the live load may occur at intervals and on some parts of the structure only, causing different loadings on columns. Consequently, the pressure on the soil under different footings will vary according to the loads on the different columns, and differential settlement will occur under the various footings of one structure. Because partial settlement is inevitable, the problem turns out to be the amount of differential settlement that the structure can tolerate. The amount of differential settlement depends on the variation in the compressibility of

the soils, the thickness of the compressible material below foundation level, and the stiffness of the combined footing and superstructure. Excessive differential settlement results in cracking of concrete and damage to claddings, partitions, ceilings, and finishes.

Differential settlement may be expressed in terms of angular distortion of the structure. Bjerrum [5] indicated that the danger limits of distortion for some conditions vary between  $\frac{1}{600}$  and  $\frac{1}{150}$  depending on the damage that will develop in the building.

For practical purposes it can be assumed that the soil pressure under the effect of sustained loadings is the same for all footings, thus causing equal settlements. The sustained load (or the usual load) can be assumed to be equal to the dead load plus a percentage of the live load, which occurs very frequently on the structure. Footings then are proportioned for these sustained loads to produce the same soil pressure under all footings. In no case is the allowable soil bearing capacity to be exceeded under the dead load plus the maximum live load for each footing. Example 13.5 explains the procedure for calculating the areas of footings, taking into consideration the effect of differential settlement.

### 13.5 PLAIN CONCRETE FOOTINGS

Plain concrete footings may be used to support masonry walls or other light loads and transfer them to the supporting soil. The ACI Code, Section 14.5.2, allows the use of plain concrete pedestals and footings on soil, provided that the design stresses shall not exceed the following:

1. Maximum flexural stress in tension is less than or equal to  $5\phi\lambda\sqrt{f'_c}$  (where  $\phi = 0.60$ ).
2. Maximum stress in one-way shear (beam action) is less than or equal to  $\frac{4}{3}\phi\lambda\sqrt{f'_c}$  (where  $\phi = 0.60$ ) (ACI Code, Section 14.5.5.1).
3. Maximum shear stress in two-way action according to ACI Code, Section 14.5.5.1, is

$$\left(\frac{4}{3} + \frac{8}{3\beta}\right)\phi\lambda\sqrt{f'_c} \leq 2.66\phi\sqrt{f'_c} \quad (\text{where } \phi = 0.60) \quad (13.19)$$

where

- $\phi$  = reduction factor from ACI Code, Section 9.3.5
- $\beta$  = ratio of long side to short side of rectangular column
- $\lambda$  = modification factor described in Section 8.6.1

4. Maximum compressive strength shall not exceed the concrete bearing strengths specified;  $f'_c$  of plain concrete should not be less than 2500 psi.
5. The minimum thickness of plain concrete footings shall not be less than 8 in.
6. The critical sections for bending moments are at the face of the column or wall.
7. The critical sections for one-way shear and two-way shear action are at distances  $h$  and  $h/2$  from the face of the column or wall, respectively. Although plain concrete footings do not require steel reinforcement, it will be advantageous to provide shrinkage reinforcement in the two directions of the footing.
8. Stresses due to factored loads are computed assuming a linear distribution in concrete.
9. The effective depth,  $d$ , must be taken equal to the overall thickness minus 2 in.
10. For flexure and one-way shear, use a gross section  $bh$ , whereas for two-way shear, use  $b_0h$  to calculate  $\phi V_c$ .

**Example 13.1**

Design a reinforced concrete footing to support a 20-in.-wide concrete wall carrying a dead load of 26 K/ft, including the weight of the wall, and a live load of 20 K/ft. The bottom of the footing is 6 ft below final grade. Use normal-weight concrete with  $f'_c = 4$  ksi,  $f_y = 60$  ksi, and an allowable soil pressure of 5 ksf.

**Solution**

1. Calculate the effective soil pressure. Assume a total depth of footing of 20 in. Weight of footing is  $\left(\frac{20}{12}\right)(150) = 250$  psf. Weight of the soil fill on top of the footing, assuming that soil weighs 100 lb/ft<sup>3</sup>, is  $\left(6 - \frac{20}{12}\right) \times 100 = 433$  psf. Effective soil pressure at the bottom of the footing is  $5000 - 250 - 433 = 4317$  psf = 4.32 ksf.
2. Calculate the width of the footing for a 1-ft length of the wall:

$$\begin{aligned}\text{Width of footing} &= \frac{\text{total load}}{\text{effective soil pressure}} \\ &= \frac{26 + 20}{4.32} = 10.7 \text{ ft}\end{aligned}$$

Use 11 ft.

3. Net upward pressure = (factored load)/(footing width) (per 1 ft):

$$P_u = 1.2D + 1.6L = 1.2 \times 26 + 1.6 \times 20 = 63.2 \text{ K}$$

$$\text{Net pressure} = q_u = \frac{63.2}{11} = 5.745 \text{ ksf}$$

4. Check the assumed depth for shear requirements. The concrete cover in footings is 3 in., and assume no. 8 bars; then  $d = 20 - 3.5 = 16.5$ . The critical section for one-way shear is at a distance  $d$  from the face of the wall:

$$V_u = q_u \left( \frac{B}{2} - d - \frac{c}{2} \right) = 5.745 \left( \frac{11}{2} - \frac{16.5}{12} - \frac{20}{2 \times 12} \right) = 18.91 \text{ K}$$

$$\text{Allowable one-way shear} = 2\lambda\sqrt{f'_c} = (2)(1)\sqrt{4000} = 126.5 \text{ psi}$$

$$\text{Required } d = \frac{V_u}{\phi(2\sqrt{f'_c})b} = \frac{18.91 \times 1000}{0.75(126.5)(12)} = 16.6 \text{ in.}$$

$$b = 1 - \text{ft length of footing} = 12 \text{ in.}$$

Total depth is  $16.6 + 3.5 = 20.1$  in., or 20 in. Actual  $d$  is  $20 - 3.5 = 16.5$  in. (as assumed). Note that a few trials are needed to get the assumed and calculated  $d$  quite close.

5. Calculate the bending moment and steel reinforcement. The critical section is at the face of the wall:

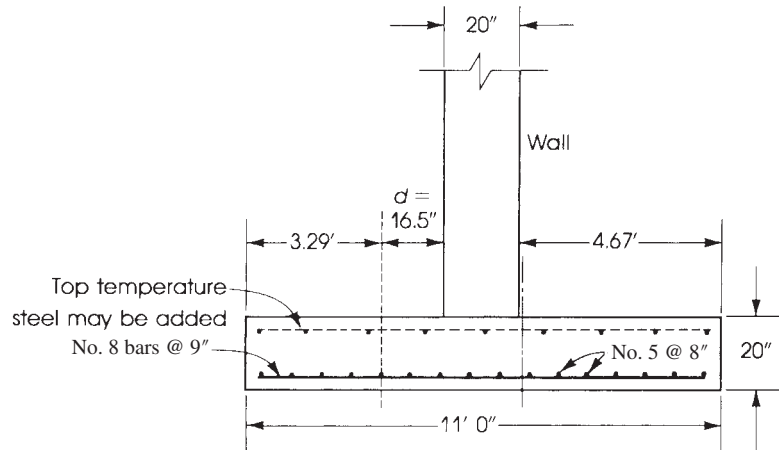
$$M_u = \frac{1}{2}q_u \left( \frac{B}{2} - \frac{c}{2} \right)^2 b = \frac{5.745}{2} \left( \frac{11}{2} - \frac{20}{24} \right)^2 (1) = 62.6 \text{ K} \cdot \text{ft}$$

$$R_u = \frac{M_u}{bd^2} = \frac{62.6 \times 12,000}{12(16.5)^2} = 230 \text{ psi}$$

From Table A.1 in Appendix A, for  $R_u = 230$  psi,  $f'_c = 4$  ksi, and  $f_y = 60$  ksi, the steel percentage is  $\rho = 0.0045$  (or from Eq. 13.14). Minimum steel percentage for flexural members is

$$\rho_{\min} = \frac{200}{f_y} = \frac{200}{60,000} = 0.0033$$





**Figure 13.17** Example 13.1: Wall footing.

Percentage of shrinkage reinforcement is 0.18% (for  $f_y = 60$  ksi). Therefore, use  $\rho = 0.0045$  as calculated.

$$A_s = 0.0045 \times 12 \times 16.5 = 0.89 \text{ in.}^2$$

Use no. 8 bars spaced at 9 in. ( $A_s = 1.05 \text{ in.}^2$ ) (Table A.14).

6. Check the development length for no. 8 bars:

$$l_d = 48d_b = 48(1) = 48 \text{ in.} \quad (\text{Refer to Chapter 7, Section 7.3.3})$$

Provided

$$l_d = \frac{B}{2} - \frac{c}{2} - 3 \text{ in.} = \frac{11(12)}{2} - \frac{20}{2} - 3 = 53 \text{ in.}$$

7. Calculate secondary reinforcement in the longitudinal direction:  $A_s = 0.0018(12)(20) = 0.43 \text{ in.}^2/\text{ft}$ . Choose no. 5 bars spaced at 8 in. ( $A_s = 0.46 \text{ in.}^2$ ). Details are shown in Fig. 13.17.

### Example 13.2

Design a square single footing to support an 18-in.-square tied interior column reinforced with eight no. 9 bars. The column carries an unfactored axial dead load of 245 K and an axial live load of 200 K. The base of the footing is 4 ft below final grade and the allowable soil pressure is 5 ksf. Use normal-weight concrete, with  $f'_c = 4$  ksi and  $f_y = 60$  ksi.

#### Solution

1. Calculate the effective soil pressure. Assume a total depth of footing of 2 ft. The weight of the footing is  $2 \times 150 = 300$  psf. The weight of the soil on top of the footing (assuming the weight of soil = 100 pcf) is  $2 \times 100 = 200$  psf.

$$\text{Effective soil pressure} = 5000 - 300 - 200 = 4500 \text{ psf}$$

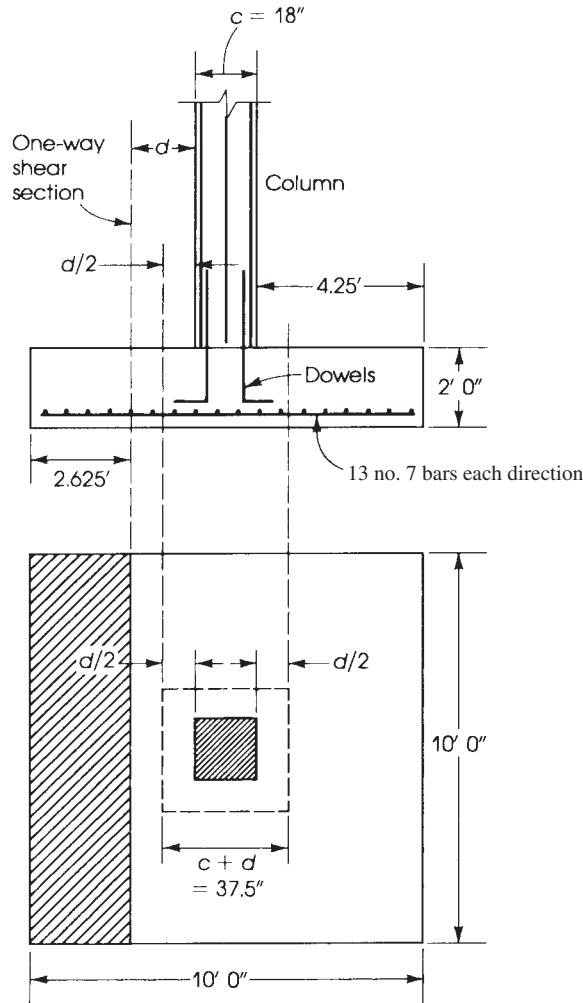
2. Calculate the area of the footing:

$$\text{Actual loads} = D + L = 245 + 200 = 445 \text{ K}$$

$$\text{Area of footing} = \frac{445}{4.5} = 98.9 \text{ ft}^2$$

$$\text{Side of footing} = 9.94 \text{ ft}$$

Thus, use 10 ft (Fig. 13.18).



**Figure 13.18** Example 13.2: Square footing.

3. Net upward pressure equals (factored load)/(area of footing):

$$P_u = 1.2D + 1.6L$$

$$= 1.2 \times 245 + 1.6 \times 200 = 614 \text{ K}$$

$$\text{Net upward pressure, } q_u = \frac{614}{10 \times 10} = 6.14 \text{ ksf}$$

4. Check depth due to two-way shear. If no shear reinforcement is used, two-way shear determines the critical footing depth required. For an assumed total depth of 24 in., calculate  $d$  to the centroid of the top layer of the steel bars to be placed in the two directions within the footing. Let the bars to be used be no. 8 bars for calculating  $d$ :

$$d = 24 - 3(\text{cover}) - 1.5(\text{bar diameters}) = 19.5 \text{ in.}$$

It is quite practical to assume  $d = h - 4.5$  in.

$$b_0 = 4(c + d) = 4(18 + 19.5) = 150 \text{ in.}$$

$$c + d = 18 + 19.5 = 37.5 \text{ in.} = 3.125 \text{ ft}$$

$$V_{u_2} = P_u - q_u(c + d)^2 = 614 - 6.14(3.125)^2 = 554 \text{ K}$$

$$\begin{aligned} \text{Required } d_1 &= \frac{V_{u_2}}{4\phi\lambda(\sqrt{f'_c}b_0)} \\ &= \frac{554(1000)}{(4)(0.75)(1)\sqrt{4000}(150)} = 19.5 \text{ in.} \quad (\beta = 1; \text{ Eq. 13.9}) \end{aligned}$$

$$\begin{aligned} \text{Required } d_2 &= \frac{554(1000)}{0.75\left(\frac{40 \times 19.5}{150} + 2\right)(\sqrt{4000})(150)} \\ &= 10.8 \text{ in.} \quad (\text{not critical}) \end{aligned}$$

( $\alpha_s = 40$  for interior columns.) Thus, the assumed depth is adequate. Two or more trials may be needed to reach an acceptable  $d$  that is close to the assumed one.

5. Check depth due to one-way shear action: The critical section is at a distance  $d$  from the face of the column:

$$\text{Distance from edge of footing} = \left(\frac{L}{2} - \frac{c}{2} - d\right) = 2.625 \text{ ft}$$

$$V_{u_1} = 6.14 \times (2.625)(10) = 161.2 \text{ K}$$

The depth required for one-way shear is

$$\begin{aligned} d &= \frac{V_{u_1}}{(0.75)(2)\lambda\sqrt{f'_c}b} \\ &= \frac{161.2(1000)}{(0.75)(2)(1)(\sqrt{4000})(10 \times 12)} = 14.2 \text{ in.} < 19.5 \text{ in.} \end{aligned}$$

6. Calculate the bending moment and steel reinforcement. The critical section is at the face of the column. The distance from edge of footing is

$$\left(\frac{L}{2} - \frac{c}{2}\right) = 5 - \frac{1.5}{2} = 4.25 \text{ ft}$$

$$M_u = \frac{1}{2}q_u\left(\frac{L}{2} - \frac{c}{2}\right)^2 b = \frac{1}{2}(6.14)(4.25)^2(10) = 554.5 \text{ K} \cdot \text{ft}$$

$$R_u = \frac{M_u}{bd^2} = \frac{554.5(12,000)}{(10 \times 12)(19.5)^2} = 145.8 \text{ psi}$$

Applying Eq. 13.14,  $\rho = 0.0028$ .

$$A_s = \rho bd = 0.0028(10 \times 12)(19.5) = 6.55 \text{ in.}^2$$

$$\text{Minimum } A_s \text{ (shrinkage steel)} = 0.0018(10 \times 12)(24)$$

$$= 5.18 \text{ in.}^2 < 6.55 \text{ in.}^2$$

$$\text{Minimum } A_s \text{ (flexure)} = 0.0033(10 \times 12)(19.5) = 7.72 \text{ in.}^2$$

Therefore,  $A_s = 7.72 \text{ in.}^2$  can be adopted. Use 13 no. 7 bars ( $A_s = 7.82 \text{ in.}^2$ ), spaced at  $s = (120 - 6)/12 = 9.5 \text{ in.}$  in both directions.

## 7. Check bearing stress:

- a. Bearing strength,  $N_1$ , at the base of the column ( $A_1 = 18 \times 18$  in.) is

$$N_1 = \phi(0.85f'_c A_1) = 0.65(0.85 \times 4)(18 \times 18) = 716 \text{ K}$$

- b. Bearing strength,  $N_2$ , of footing is

$$N_2 = N_1 \sqrt{\frac{A_2}{A_1}} \leq 2N_1$$

$$A_2 = 10 \times 10 \times 144 = 14,400 \text{ in.}^2 \quad A_1 = 18 \times 18 = 324 \text{ in.}^2$$

$$\sqrt{\frac{A_2}{A_1}} = 6.67 > 2$$

Therefore,  $N_2 = 2N_1 = 1432 \text{ K}$ . Because  $P_u = 614 \text{ K} < N_2$ , bearing strength is adequate. The minimum area of dowels required is  $0.005A_1 = 0.005(18 \times 18) = 1.62 \text{ in.}^2$ . The minimum number of bars is four, so use four no. 8 bars placed at the four corners of the column.

- c. Development length of dowels in compression:

$$l_{dc} = \frac{0.02d_b f_y}{\lambda \sqrt{f'_c}} = \frac{0.02(1)(60,000)}{(1)\sqrt{4000}} = 19 \text{ in.}$$

(controls). Minimum  $l_{dc}$  is  $0.0003d_b f_y = 0.0003(1)(60,000) = 18 \text{ in.} \geq 8 \text{ in.}$  Therefore, use four no. 8 dowels extending 19 in. into column and footing. Note that  $l_d$  is less than  $d$  of 19.5 in., which is adequate.

8. The development length of main bars in footing for no. 7 bars is  $l_d = 48d_b = 42 \text{ in.}$  (refer to Chapter 7), provided  $l_d = L/2 - c/2 - 3 \text{ in.} = 48 \text{ in.}$  Details of the footing are shown in Fig. 13.18.

**Example 13.3**

Design a rectangular footing for the column of Example 13.2 if one side of the footing is limited to 8.5 ft.

**Solution**

- The design procedure for rectangular footings is similar to that of square footings, taking into consideration the forces acting on the footing in each direction separately.
- From the previous example, the area of the footing required is  $98.9 \text{ ft}^2$ :

$$\text{Length of footing} = \frac{98.9}{8.5} = 11.63 \text{ ft}$$

so use 12 ft (Fig. 13.18). Footing dimensions are  $8.5 \times 12 \text{ ft}$ .

- $P_u = 614 \text{ K}$ . Thus, net upward pressure is

$$q_u = \frac{614}{8.5 \times 12} = 6.02 \text{ ksf}$$

- Check the depth due to one-way shear. The critical section is at a distance  $d$  from the face of the column. In the longitudinal direction,

$$\begin{aligned} V_{u_1} &= \left( \frac{L}{2} - \frac{c}{2} - d \right) \times q_u b \\ &= \left( \frac{12}{2} - \frac{1.5}{2} - \frac{19.5}{12} \right) \times 6.02 \times 8.5 = 185.5 \text{ K} \end{aligned}$$

This shear controls. In the short direction,  $V_u = 135.4$  K (not critical):

$$\text{Required } d = \frac{V_{u1}}{2\phi\lambda\sqrt{f'_c}b} = \frac{185.5 \times 1000}{(2)(0.75)(1)\sqrt{4000} \times (8.5 \times 12)} = 19.2 \text{ in.}$$

$$d \text{ provided} = 19.5 \text{ in.} > 19.2 \text{ in.}$$

5. Check the depth for two-way shear action (punching shear). The critical section is at a distance  $d/2$  from the face of the column on four sides:

$$b_0 = 4(18 + 19.5) = 150 \text{ in.}$$

$$c + d = 18 + 19.5 = 37.5 \text{ in.} = 3.125 \text{ ft}$$

$$\beta = \frac{12}{8.5} = 1.41 < 2$$

(Use  $V_c = 4\phi\lambda\sqrt{f'_c}b_0d$ )

$$V_{u2} = P_u - q_u(c + d)^2 = 614 - 6.02(3.125)^2 = 555.2 \text{ K}$$

$$d_1 = \frac{V_{u2}}{4\phi\lambda\sqrt{f'_c}b_0} = \frac{555.2 \times 1000}{4(0.75)(1)\sqrt{4000} \times 150} = 19.5 \text{ in.}$$

$$d_2 = 10.6 \text{ in. (Does not control.)}$$

6. Design steel reinforcement in the longitudinal direction. The critical section is at the face of the support. The distance from the edge of the footing is

$$\frac{L}{2} - \frac{c}{2} = \frac{12}{2} - \frac{1.5}{2} = 5.25 \text{ ft}$$

$$M_u = \frac{1}{2}(6.02)(5.25)^2(8.5) = 705.2 \text{ K} \cdot \text{ft}$$

$$R_u = \frac{M_u}{bd^2} = \frac{705.2(12,000)}{(8.5 \times 12)(19.5)^2} = 218 \text{ psi}$$

Applying Eq. 13.14,  $\rho = 0.0042$ :

$$A_s = 0.0042(8.5 \times 12)(19.5) = 8.35 \text{ in.}^2$$

$$\text{Min } A_s \text{ (shrinkage)} = 0.0018(8.5 \times 12)(24) = 4.4 \text{ in.}^2$$

$$\text{Min } A_s \text{ (flexure)} = 0.0033(8.5 \times 12)(19.5) = 6.56 \text{ in.}^2$$

Use  $A_s = 8.35$  in. and 10 no. 9 bars ( $A_s = 10$  in.<sup>2</sup>) spaced at  $S = (102 - 6)/9 = 10.7$  in.

7. Design steel reinforcement in the short direction. The distance from the face of the column to the edge of the footing is

$$\frac{8.5}{2} - \frac{1.5}{2} = 3.5 \text{ ft}$$

$$M_u = \frac{1}{2}(6.02)(3.5)^2(12) = 422.5 \text{ K} \cdot \text{ft}$$

$$R_u = \frac{M_u}{bd^2} = \frac{422.5(12,000)}{(12 \times 12)(19.5)^2} = 97 \text{ psi}$$

Applying Eq. 13.4,  $\rho = 0.0019$ :

$$A_s = 0.0019(12 \times 12)(19.5) = 5.34 \text{ in.}^2$$

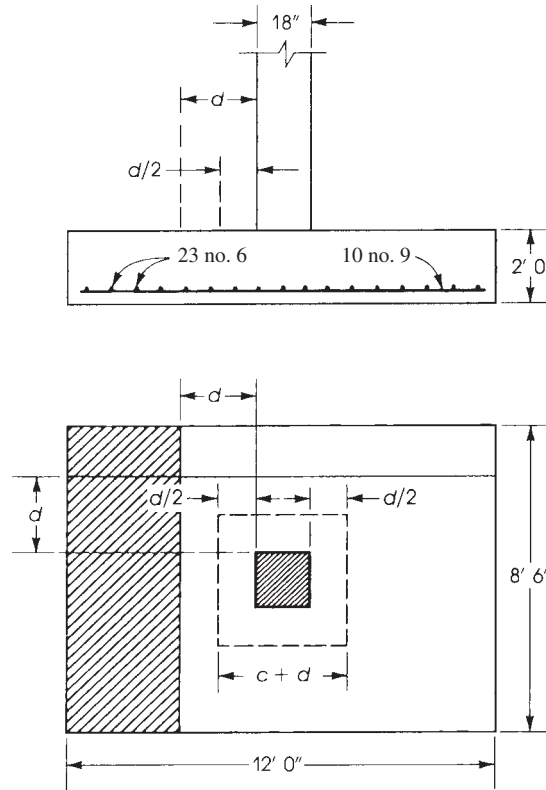
$$\text{Min } A_s \text{ (shrinkage)} = 0.0018(12 \times 12)(24) = 6.22 \text{ in.}^2$$

$$\text{Min } A_s \text{ (flexure)} = 0.0033(12 \times 12)(19.5) = 9.26 \text{ in.}^2$$

The value of  $A_s$  to be used must be greater than or equal to  $9.26 \text{ in.}^2$ . Use 22 no. 6 bars ( $A_s = 9.68 \text{ in.}^2$ ):

$$\gamma_s = \frac{2}{\beta + 1} = \frac{2}{(12/8.5) + 1} = 0.83$$

The number of bars in an 8.5-ft band is  $22(0.83) = 19$  bars. The number of bars left on each side is  $\frac{1}{2}(22 - 19) \approx 2$  bars. Therefore, place 19 no. 6 bars within the 8.5-ft band; then place 2 no. 6 bars ( $A_s = 0.88 \text{ in.}^2$ ) within  $(12 - 8.5)/2 = 1.63$  ft on each side of the band. The total number of bars is 23 no. 6 bars ( $A_s = 10.12 \text{ in.}^2$ ). Details of reinforcement are shown in Fig. 13.19.



**Figure 13.19** Example 13.3: Rectangular footing.

8. Check the bearing stress at the base of the column, as explained in the previous example. Use four no. 8 dowel bars.

- a. Bearing strength  $N_1$  at the base of the column ( $A_1 = 18 \times 18 \text{ in.}$ ) is

$$N_1 = \phi(0.85f'_cA_1) = 0.65(0.85 \times 4)(18 \times 18) = 716 \text{ K} > P_u = 614 \text{ K} \quad \text{OK}$$

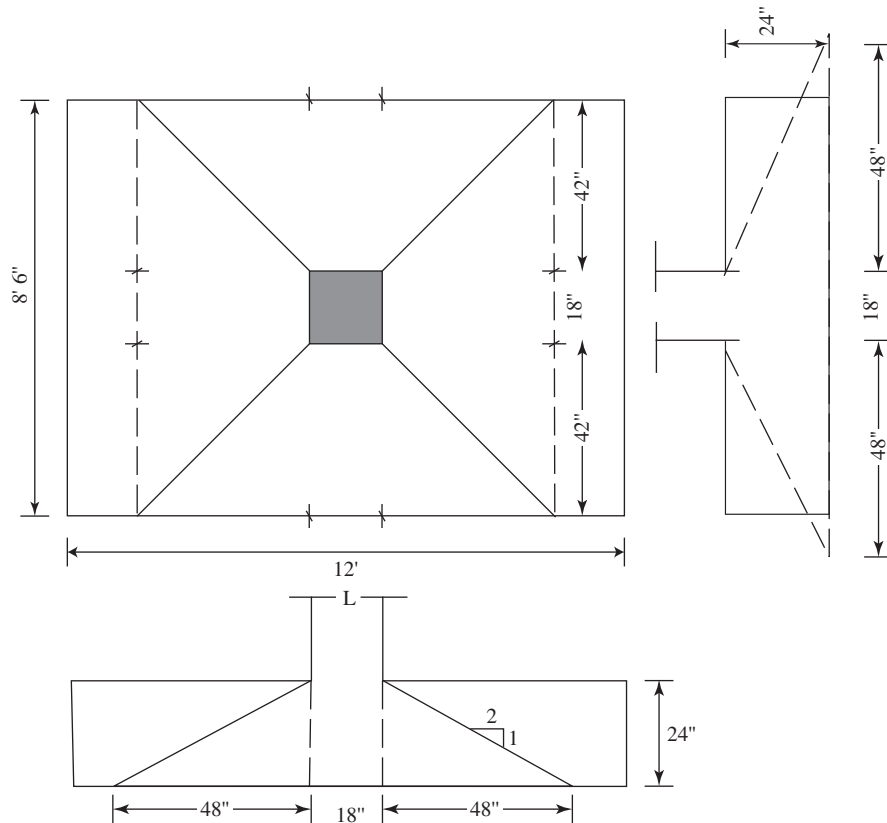
- b. Bearing strength  $N_2$  of footing is

$$N_2 = N_1 \sqrt{\frac{A_2}{A_1}} \leq 2N_1$$

$$A_1 = 18 \times 18 = 324 \text{ in.}^2$$

$$A_2 = (48 + 18 + 48)(42 + 18 + 42) = 11,628 \text{ in.}^2 \text{ (Fig. 13.20)}$$

$$\sqrt{\frac{A_2}{A_1}} = \sqrt{\frac{11,628}{324}} = 5.99 > 2$$



**Figure 13.20** Example 13.3: Rectangular footing.

Therefore, use

$$N_2 = 2[\phi(0.85f'_cA_1)] = 2[0.65(0.85 \times 4 \times 18 \times 18)] = 1432 \text{ kips}$$

because  $P_u = 614 < N_2$  bearing strength is adequate to transfer the factored loads. The minimum area of dowels required is

$$A_{s,\min} = 0.005A_1 = 0.005(18 \times 18) = 1.62 \text{ in.}^2$$

Provide four no. 8 bars placed at the four corners of the column.

c. Development length of dowels in compression:

$$\begin{aligned} l_{dc} &= \left( \frac{0.02f_y}{\lambda\sqrt{f'_c}} \right) (0.875) \geq (0.0003f_y)d_b \\ &= \left( \frac{0.02(60,000)}{1.0\sqrt{4000}} \right) (0.875) = 16.6 \text{ in.} \end{aligned}$$

$$l_{dc(\min)} = 0.0003(60,000)(0.875) = 15.8 \text{ in.} \geq 8 \text{ in.}$$

and

$$\begin{aligned} \text{Available length for development in footing} &= 24 - 3 - (1.125 + 0.75) - 0.875 \\ &= 18.25 \text{ in} > 16.60 \text{ in.} \end{aligned}$$

Dowels can be fully developed in the footing.

9. Development length of the main reinforcement:  $l_d = 29$  in. for no. 6 bars and 54 in. for no. 9 bars:

$$\text{Provided } l_d(\text{long direction}) = \left( \frac{L}{2} - \frac{c}{2} - 3 \text{ in.} \right) = 60 \text{ in.}$$

$$\text{Provided } l_d(\text{short direction}) = 39 \text{ in.} > 29 \text{ in.}$$

### Example 13.4

Determine transfer of force between column and footing for a  $14 \times 14$ -in. tied column with four no. 11 longitudinal bars:  $f'_c = 4000$  psi,  $f_y = 60,000$  psi, axial dead load = 250 kips, axial live load  $P_L = 150$  kips, and footing size is  $10 \times 10$  ft.

#### Solution

- Determine the factored load  $P_u = 1.2 \times 250 + 1.6 \times 150 = 540$  K
- Bearing strength of column concrete:

$$\phi P_{nb} = \phi(0.85f'_c A_1) = 0.65(0.85 \times 4 \times 14 \times 14) = 433 \text{ K} < P_u = 540 \text{ K}$$

The bearing strength of the column is less than the axial load. So concrete only cannot transfer the load to the footing. The excess load ( $540 - 433 = 107$  kips) must be transferred by reinforcement.

- Bearing strength of footing concrete:

$$\phi P_{nb} = \sqrt{\frac{A_2}{A_1}} \phi(0.85f'_c A_1)$$

$$A_2 = \sqrt{\frac{10 \times 10 \times 144}{14 \times 14}} = 8.6 > 2$$

Use 2:

$$\phi P_{nb} = 2(433) = 866 \text{ K} > P_u = 540 \text{ K} \quad \text{safe}$$

- Required area of dowel bar:

$$A_s = \frac{P_u - \phi P_{nb}}{\phi f_y} = \frac{540 - 433}{0.65 \times 60} = 2.74 \text{ in.}^2$$

$$A_{s,\min} = 0.005(14 \times 14) = 0.98 \text{ in.}^2$$

Provide four no. 8 bars ( $A_s = 3.16 \text{ in.}^2$ ).

- Development of dowel reinforcement

- For development into the column (Fig. 13.21) no. 11 bar may be lap spliced with no. 8 dowel bars. Dowels must extend into the column:

$$\text{Greater of } \rightarrow \left\{ \begin{array}{l} \text{Development length of no. 11 bars} \\ \text{Lap splice length of no. 8 footing dowels} \end{array} \right\}$$

For no. 11 bars:

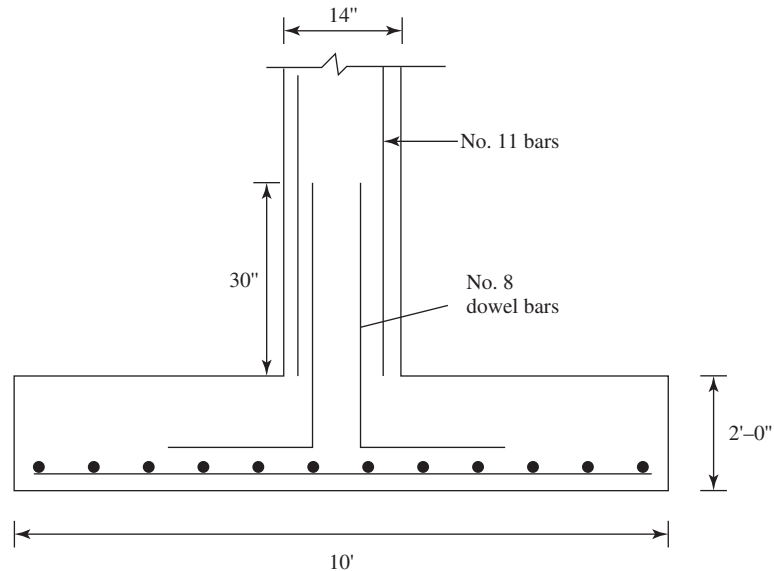
$$l_{dc} = \left[ \frac{0.02f_y}{\lambda \sqrt{f'_c}} \right] d_b = \left[ \frac{0.02(60,000)}{1.0 \sqrt{4000}} \right] 1.41 = 26.75 \text{ in.}$$

$$l_{dc,\min} = (0.0003f_y)d_b = 0.0003 \times 60,000 \times 1.41 = 25.38 \text{ in.}$$

For no. 8 bars:

$$\text{Lap splice length} = (0.0005)f_y d_b = 0.0005(60,000)(1.0) = 30 \text{ in. (governs)}$$





**Figure 13.21** Example 13.4 Dowels details.

Lap length of no. 8 bars governs. No. 8 dowel bars should extend not less than 30 in. into the column.

- b.** For development into the footing, no. 8 dowels must extend full development length:

$$l_{dc} = \left[ \frac{0.02f_y}{\lambda\sqrt{f'_c}} \right] d_b = \left[ \frac{0.02(60,000)}{1.0\sqrt{4000}} \right] (1.0) = 19 \text{ in.}$$

$$l_{dc,\min} = (0.0003f_y)d_b = 0.0003 \times 60,000 \times 1.0 = 18 \text{ in.}$$

The length may be reduced to account for excess reinforcement according to ACI Code, Section 12.3.3:

$$\frac{A_s(\text{required})}{A_s(\text{provided})} = \frac{2.74}{3.16} = 0.86$$

$$l_{dc} = 0.86 \times 19 = 16.47 \text{ in.}$$

Then

$$\begin{aligned} \text{Available length for dowel development} &= 24 - 3 - 2(0.875) - 1.0 \\ &= 18.25 \text{ in.} > 16.47 \text{ required (safe)} \end{aligned} \text{(Fig.13.21)}$$

### Example 13.5

Determine the footing areas required for equal settlement (balanced footing design) if the usual live load is 20% for all footings. The footings are subjected to dead loads and live loads as indicated in the following table. The allowable net soil pressure is 6 ksf.

	Footing Number				
	1	2	3	4	5
Dead load	120 K	180 K	140 K	190 K	210 K
Live load	150 K	220 K	200 K	170 K	240 K

**Solution**

1. Determine the footing that has the largest ratio of live load to dead load. In this example, footing 3 ratio of 1.43 is higher than the other ratios.
2. Calculate the usual load for all footings. The usual load is the dead load and the portion of live load that most commonly occurs on the structure. In this example,

$$\text{Usual load} = DL + 0.2(LL)$$

The values of the usual loads are shown in the following table.

3. Determine the area of the footing that has the highest ratio of LL/DL:

$$\text{Area of footing} \rightarrow 3 = \frac{DL + LL}{\text{allowable soil pressure}} = \frac{140 + 200}{6} = 56.7 \text{ ft}^2$$

The usual soil pressure under footing 3 is

$$\frac{\text{Usual load}}{\text{Area of footing}} = \frac{180}{56.7} = 3.18 \text{ ksf}$$

4. Calculate the area required for each footing by dividing its usual load by the soil pressure of footing 3. The areas are tabulated in the following table. For footing 1, for example, the required area is  $150/3.18 = 47.2 \text{ ft}^2$ .
5. Calculate the maximum soil pressure under each footing:

$$q_{\max} = \frac{D + L}{\text{area}} \leq 6 \text{ ksf} \quad (\text{allowable soil pressure})$$

Description	By Footing Number				
	1	2	3	4	5
Live load					
Dead load	1.25	1.22	1.43	0.90	1.14
Usual load = DL + 0.2 (LL) (kips)	150	224	180	224	258
Area required = $\frac{\text{usual load}}{3.18 \text{ ksf}}$ (ft <sup>2</sup> )	47.2	70.4	56.7	70.4	81.1
Max. soil pressure = $\frac{D + L}{\text{area}}$ (ksf)	5.72	5.68	6.00	5.11	5.55

**Example 13.6**

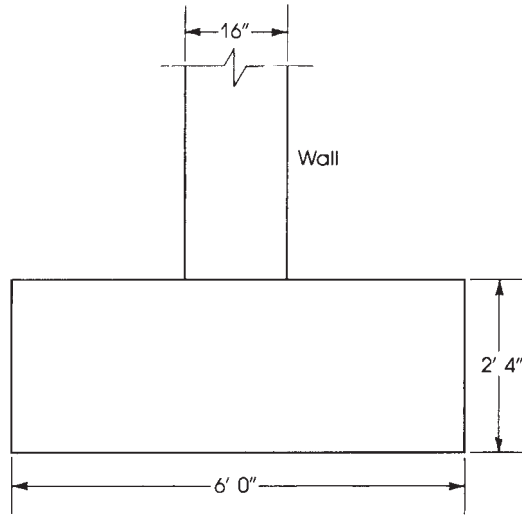
Design a plain concrete footing to support a 16-in.-thick concrete wall. The loads on the wall consist of a 16-K/ft dead load (including the self-weight of wall) and a 10-K/ft live load. The base of the footing is 4 ft below final grade. Use  $f'_c = 3 \text{ ksi}$  and an allowable soil pressure of 5 ksf.

**Solution**

1. Calculate the effective soil pressure. Assume a total depth of footing of 28 in.:

$$\text{Weight of footing} = \frac{28}{12} \times 145 = 338 \text{ psf}$$

The weight of the soil, assuming that soil weighs 100 pcf, is  $(4 - 2.33) \times 100 = 167 \text{ psf}$ . Effective soil pressure is  $5000 - 338 - 167 = 4495 \text{ psf}$ .



**Figure 13.22** Example 13.6: Plain concrete wall footing.

2. Calculate the width of the footing for a 1-ft length of the wall ( $b = 1$  ft):

$$\begin{aligned}\text{Width of footing} &= \frac{\text{total load}}{\text{effective soil pressure}} \\ &= \frac{16 + 10}{4.495} = 5.79 \text{ ft}\end{aligned}$$

Use 6.0 ft (Fig. 13.22).

3.  $U = 1.2D + 1.6L = 1.2 \times 16 + 1.6 \times 10 = 35.2$  K/ft. The net upward pressure is  $q_u = 35.2/6 = 5.87$  ksf.
4. Check bending stresses. The critical section is at the face of the wall. For a 1-ft length of wall and footing,

$$M_u = \frac{1}{2}q_u \left( \frac{L}{2} - \frac{c}{2} \right)^2 = \frac{1}{2}(5.87) \left( \frac{6}{2} - \frac{16}{2 \times 12} \right)^2 = 16 \text{ K} \cdot \text{ft}$$

Let the effective depth,  $d$ , be  $28 - 2 = 26$  in., assuming that the bottom 3 in. is not effective:

$$I_g = \frac{bd^3}{12} = \frac{12}{12}(26)^3 = 17,576 \text{ in.}^2$$

The flexural tensile stress is

$$f_t = \frac{M_u c}{I} = \frac{16 \times 12,000}{17,576} \left( \frac{25}{2} \right) = 137 \text{ psi}$$

The allowable flexural tensile stress is  $5\phi\sqrt{f'_c} = 5 \times 0.60\sqrt{3000} = 164$  psi (safe).

5. Check shear stress: The critical section is at a distance  $d = 26$  in. from the face of the wall:

$$V_u = q_u \left( \frac{L}{2} - \frac{c}{2} - d \right) = 5.87 \left( \frac{6}{2} - \frac{16}{2 \times 12} - \frac{26}{12} \right) = 0.98 \text{ K}$$

$$\phi V_c = \phi \left( \frac{4}{3} \right) \lambda \sqrt{f'_c} b d = \frac{(0.60) \left( \frac{4}{3} \right) (1) \sqrt{3000} (12) (26)}{1000} = 13.67 \text{ K}$$

Therefore, the section is adequate. It is advisable to use minimum reinforcement in both directions.

13.6 COMBINED FOOTINGS

When a column is located near a property line, part of the single footing might extend into the neighboring property. To avoid this situation, the column may be placed on one side or edge of the footing causing eccentric loading. This may not be possible under certain conditions, and sometimes it is not an economical solution. A better design can be achieved by combining the footing with the nearest internal column footing, forming a combined footing. The center of gravity of the combined footing coincides with the resultant of the loads on the two columns.

Another case where combined footings become necessary is when the soil is poor and the footing of one column overlaps the adjacent footing. The shape of the combined footing may be rectangular or trapezoidal (Fig. 13.23). When the load of the external column near the property line is greater than the load of the interior column, a trapezoidal footing may be used to keep the centroid of footing in line with the resultant of the two column loads. In most other cases, a rectangular footing is preferable.

The length and width of the combined footing are chosen to the nearest 3 in., which may cause a small variation in the uniform pressure under the footing, but it can be tolerated. For a uniform upward pressure, the footing will deflect, as shown in Fig. 13.24. The ACI Code, Section 13.3,

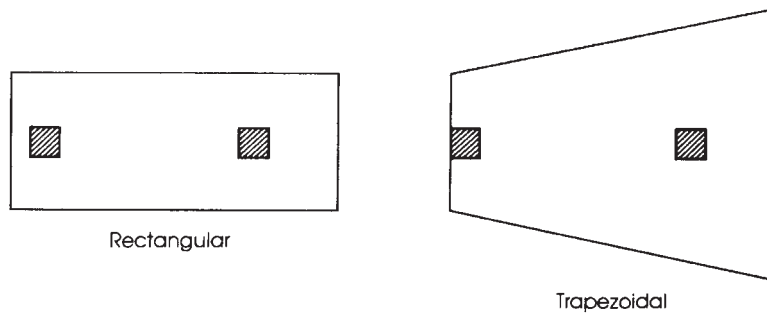


Figure 13.23 Combined footings.

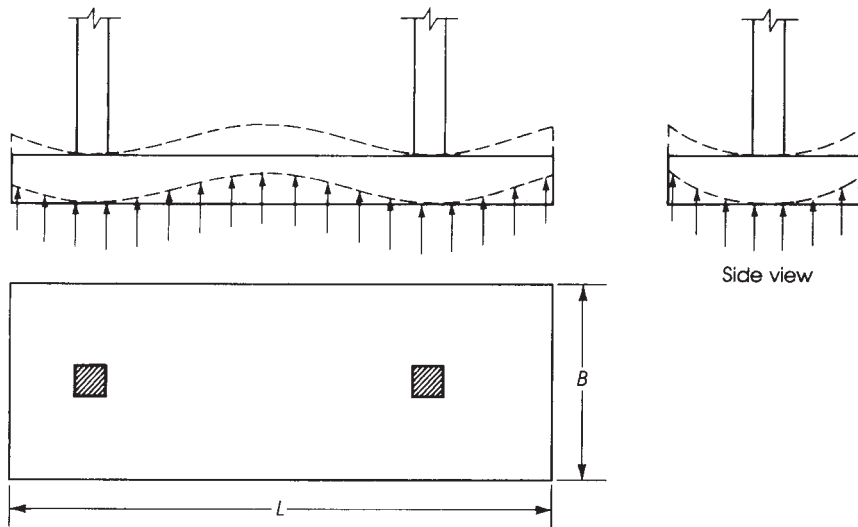
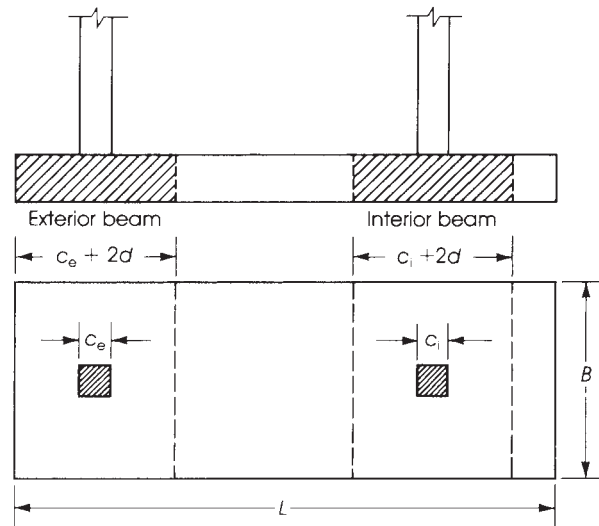


Figure 13.24 Upward deflection of a combined footing in two directions.



**Figure 13.25** Analysis of combined footing in the transverse direction.

does not provide a detailed approach for the design of combined footings. The design, in general, is based on structural analysis.

A simple method of analysis is to treat the footing as a beam in the longitudinal direction, loaded with uniform upward pressure,  $q_u$ . For the transverse direction, it is assumed that the column load is spread over a width under the column equal to the column width plus  $d$  on each side, whenever that is available. In other words, the column load acts on a beam under the column within the footing, which has a maximum width of  $c + 2d$  and a length equal to the short side of the footing (Fig. 13.25). A smaller width, down to  $c + d$  may be used. The next example explains the design method in detail.

### Example 13.7

Design a rectangular combined footing to support two columns, as shown in Fig. 13.26. The edge column, I, has a section  $16 \times 16$  in. and carries a DL of 180 K and an LL of 120 K. The interior column, II, has a section  $20 \times 20$  in. and carries a DL of 250 K and an LL of 140 K. The allowable soil pressure is 5 ksf and the bottom of the footing is 5 ft below final grade. Design the footing using  $f'_c = 4$  ksi,  $f_y = 60$  ksi.

### Solution

1. Determine the location of the resultant of the column loads. Take moments about the center of the exterior column I:

$$x = \frac{(250 + 140) \times 16}{(250 + 140) + (180 + 120)} = 9 \text{ ft from column I}$$

The distance of the resultant from the property line is  $9 + 2 = 11.0$  ft. The length of the footing is  $2 \times 11 = 22.0$  ft. In this case the resultant of column loads will coincide with the resultant of the upward pressure on the footing.

2. Determine the area of the footing. Assume the footing total depth is 36 in. ( $d = 36 - 4.5 = 31.5$  in.).

$$\text{Total actual (working) loads} = 300 + 390 = 690 \text{ K}$$

$$\text{New upward pressure} = 5000 - \left( \frac{36}{12} \times 150 \right) - (2 \times 100) = 4350 \text{ psf}$$

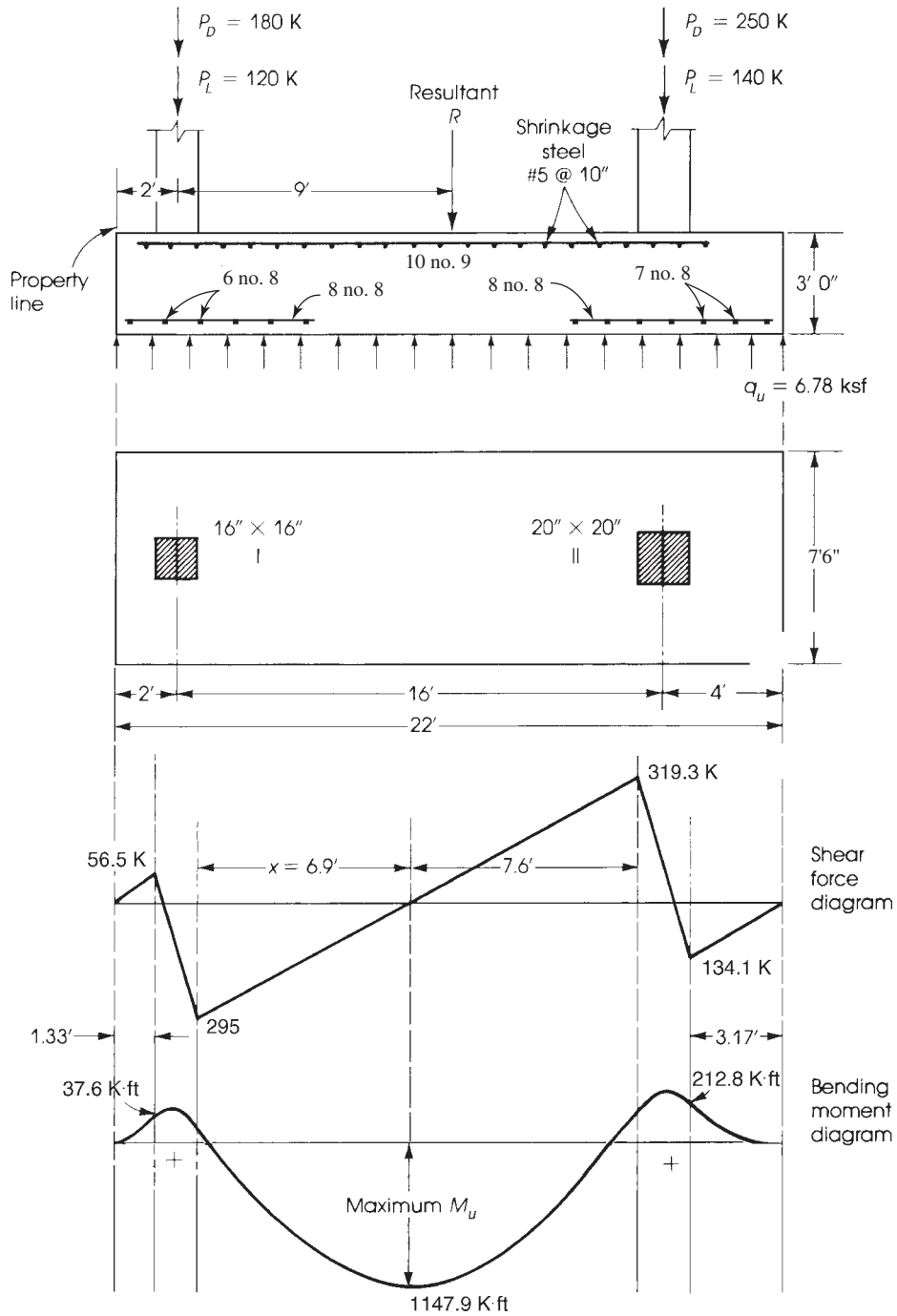


Figure 13.26 Example 13.6: Design of a combined footing.

(Assumed density of soil is 100 psf)

$$\text{Required area} = \frac{690}{4.35} = 158.6 \text{ ft}^2$$

$$\text{Width of footing} = \frac{158.6}{22} = 7.21 \text{ ft}$$

Use 7.5 ft. Choose a footing  $22 \times 7.5$  ft (area =  $165 \text{ ft}^2$ ).

3. Determine the factored upward pressure using factored loads:

$$P_{u1}(\text{column I}) = 1.2 \times 180 + 1.6 \times 120 = 408 \text{ K}$$

$$P_{u2}(\text{column II}) = 1.2 \times 250 + 1.6 \times 140 = 524 \text{ K}$$

The net factored soil pressure is  $q_u = (408 + 524)/165 = 5.65 \text{ ksf}$ .

4. Draw the factored shearing force diagram as for a beam of  $L = 22$  ft supported on two columns and subjected to an upward pressure of  $5.65 \text{ ksf} \times 7.5$  (width of footing) =  $42.38 \text{ K/ft}$  (per foot length of footing):

$$V_u(\text{at outer face column I}) = 42.38 \left(2 - \frac{8}{12}\right) = 56.5 \text{ K}$$

$$V_u(\text{at interior face column I}) = 408 - 42.38 \left(2 + \frac{8}{12}\right) = 295 \text{ K}$$

$$V_u(\text{at outer face column II}) = 42.38 \left(4 - \frac{10}{12}\right) = 134.2 \text{ K}$$

$$V_u(\text{at interior face column II}) = 524 - \left(4 + \frac{10}{12}\right) \times 42.38 = 319.1 \text{ K}$$

Find the point of zero shear,  $x$ ; the distance between interior faces of columns I and II is

$$16 - \frac{8}{12} - \frac{10}{12} = 14.5 \text{ ft}$$

$$x = \frac{295}{295 + 319.3}(14.5) = 6.9 \text{ ft}$$

5. Draw the factored moment diagram considering the footing as a beam of  $L = 22$  ft supported by the two columns. The uniform upward pressure is  $42.38 \text{ K/ft}$ .

$$M_{u1}(\text{at outer face column I}) = 42.38 \frac{(2 - 8/12)^2}{2} = 37.5 \text{ K} \cdot \text{ft}$$

$$M_{u2}(\text{at outer face column II}) = 42.38 \frac{(4 - 10/12)^2}{2} = 212.9 \text{ K} \cdot \text{ft}$$

The maximum moment occurs at zero shear:

$$\begin{aligned} \text{Maximum } M_u \text{ (calculated from column I side)} &= 408 \left(6.9 + \frac{8}{12}\right) - \frac{42.38}{2} \left(6.9 + \frac{8}{12} + 2\right)^2 \\ &= 1147.9 \text{ K} \cdot \text{ft} \end{aligned}$$

$$\begin{aligned} \text{Maximum } M_u \text{ (from column II side)} &= 524 \left(7.6 + \frac{10}{12}\right) - \frac{42.38}{2} \left(7.6 + \frac{10}{12} + 4\right)^2 \\ &= 1143.4 \text{ K} \cdot \text{ft} \end{aligned}$$

The moments calculated from both sides of the footings are close enough, and  $M_{u,\max} = 1147.9 \text{ K} \cdot \text{ft}$  may be adopted. This variation occurred mainly because of the adjustment of the length and width of the footing.

6. Check the depth for one-way shear. Maximum shear occurs at a distance  $d = 31.5$  in. from the interior face of column II (Fig. 13.26):

$$V_{u1} = 319.3 - \frac{31.5}{12}(42.38) = 208.1 \text{ K}$$

$$d = \frac{V_{u1}}{\phi(2\lambda\sqrt{f'_c})b} = \frac{208.1 \times 1000}{0.75(2 \times 1 \times \sqrt{4000})(7.5 \times 12)} = 24.4 \text{ in.}$$

The effective depth provided is 31.5 in.  $> 24.4$  in.; thus, the footing is adequate.

7. Check depth for two-way shear (punching shear). For the interior column,

$$b_0 = 4(c + d) = \left(\frac{4}{12}\right)(20 + 31.5) = 17.17 \text{ ft}$$

$$c + d = \frac{20 + 31.5}{12} = 4.29 \text{ ft}$$

The shear  $V_{u1}$  at a section  $d/2$  from all sides of the column is equal to

$$V_{u2} = P_{u2} - q_u(c + d)^2 = 524 - 5.65(4.29)^2 = 420 \text{ K}$$

$$d = \frac{V_{u2}}{\phi(4\lambda\sqrt{f'_c})b_0} = \frac{420(1000)}{0.75(4 \times 1 \times \sqrt{4000})(17.7 \times 12)} = 10.4 \text{ in.} < 31.5 \text{ in.}$$

The exterior column is checked and proved not to be critical.

8. Check the depth for moment and determine the required reinforcement in the long direction:

$$\text{Maximum bending moment} = 1147.9 \text{ K} \cdot \text{ft}$$

$$R_u = \frac{M_u}{bd^2} = \frac{1147.9(12,000)}{(7.5 \times 12)(31.5)^2} = 154.1 \text{ psi}$$

Applying Eq. 13.14, the steel percentage is  $\rho = 0.0029 < 0.0033$  ( $\rho_{\min}$ ), use  $\rho = 0.0033$ :

$$A_s = 0.0033(7.5 \times 12)(31.5) = 9.35 \text{ in.}^2$$

$$\text{Min } A_s \text{ (shrinkage)} = 0.0018(7.5 \times 12)(3 \times 12) = 5.83 \text{ in.}^2$$

$$A_s = 9.35 \text{ in.}^2 \text{ controls. Use 10 No. 9 bars } (A_s = 10 \text{ in.}^2).$$

$$\text{Spacing of bars} = \frac{(7.5 \times 12) - 6(\text{concrete cover})}{9(\text{no. of spacings})} = 9.33 \text{ in.}$$

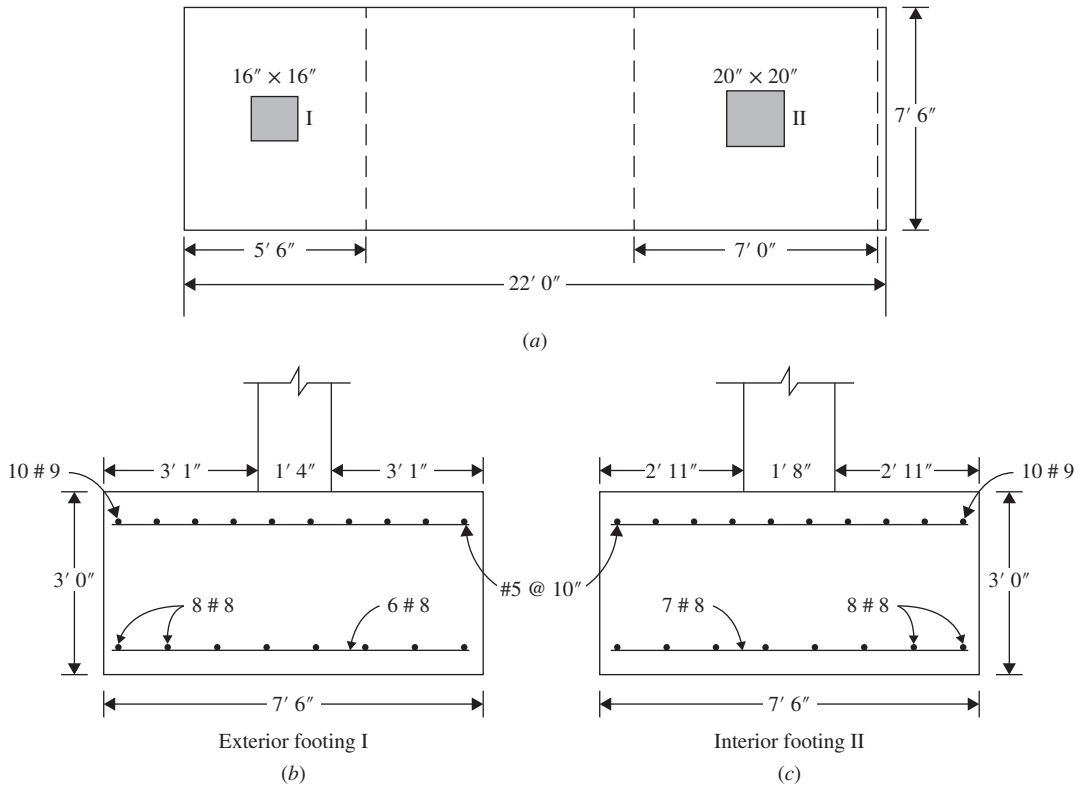
The bars are extended between the columns at the top of the footing with a concrete cover of 3 in. Place minimum reinforcement at the bottom of the projecting ends of the footing beyond the columns to take care of the positive moments. Extend the bars a development length  $l_d$  beyond the side of the column.

The minimum shrinkage reinforcement is 5.83 in.<sup>2</sup> Use eight no. 8 bars ( $A_s = 6.3$  in.<sup>2</sup>).

The development length required for the main top bars is  $1.3l_d = 1.3(54) = 70$  in. (Table 7.2) beyond the point of maximum moment. Development lengths provided to both columns are adequate.

9. For reinforcement in the short direction, calculate the bending moment in the short (transverse) direction, as in the case of single footings. The reinforcement under each column is to be placed within a maximum bandwidth equal to the column width plus twice the effective depth  $d$  of the footing (Fig. 13.27). If the distance on any side of the column less than the effective depth  $d$  then use that value on that side.





**Figure 13.27** Design of combined footing, transverse direction: (a) plan, (b) exterior footing, and (c) interior footing.

**a.** Reinforcement under exterior column I:

$$\begin{aligned}
 \text{Bandwidth} &= 16 \text{ in. (column width)} \\
 &+ 16 \text{ in. (on exterior side of column } 2 \times 12 - 16/2) \\
 &+ 31.5 \text{ in. (} d) \\
 &= 63.5 \text{ in.} = 5.3 \text{ ft}
 \end{aligned}$$

Use 5.5 ft. The net upward pressure in the short direction under column I is equal to:

$$\frac{P_{u1}}{\text{width of footing}} = \frac{408}{7.5} = 54.4 \text{ K/ft}$$

Distance from the free end to the face of the column is  $\frac{7.5}{2} - \frac{8}{12} = 3.08 \text{ ft}$

$$M_u (\text{at face of column I}) = \frac{54.4}{2} (3.08)^2 = 258.0 \text{ K} \cdot \text{ft}$$

$$R_u = \frac{M_u}{bd^2} = \frac{258.0 \times 12,000}{(5.5 \times 12)(31.5)^2} = 47.3 \text{ psi}$$

The steel percentage,  $\rho$ , = 0.0009 (Equation 13.14) is less than minimum  $\rho$  for a shrinkage reinforcement ratio of 0.0018:

$$\text{Min } A_s (\text{shrinkage}) = (0.0018)(5.5 \times 12)(36) = 4.3 \text{ in.}^2$$

Use six no. 8 bars ( $A_s = 4.71 \text{ in.}^2$ ) placed within the bandwidth of 66 in.

**b. Reinforcement under the interior column II:**

$$\text{Bandwidth} = 20 + 31.5 + 31.5 = 83 \text{ in.} = 6.91 \text{ ft}$$

Use 7 ft(84 in.).

The steel percentage,  $\rho = 0.0008$  is less than minimum  $\rho$  for shrinkage reinforcement ratio of 0.0018:

$$\text{Min } A_s \text{ (shrinkage)} = (0.0018)(7 \times 12)(36) = 5.44 \text{ in.}^2$$

Use seven no. 8 bars placed within the bandwidth of 84 in. under column II, as shown in Figs. 13.26 and 13.27. The development length  $l_d$  of no. 8 bars in the short direction is 48 in.

Though not required by code, it is recommended to provide in the shorter direction at the top of the footing no. 5 bars at 10 in. center-to-center to prevent possible shrinkage cracks and to hold the reinforcement in the other direction.

**13.7 FOOTINGS UNDER ECCENTRIC COLUMN LOADS**

When a column transmits axial loads only, the footing can be designed such that the load acts at the centroid of the footing, producing uniform pressure under the footing. However, in some cases, the column transmits an axial load and a bending moment, as in the case of the footings of fixed-end frames. The pressure  $q$  that develops on the soil will not be uniform and can be evaluated from the following equation:

$$q = \frac{P}{A} \pm \frac{Mc}{I} \geq 0 \quad (13.20)$$

where  $A$  and  $I$  are the area and moment of inertia of the footing, respectively. Different soil conditions exist, depending on the magnitudes of  $P$  and  $M$  and allowable soil pressure. The different design conditions are shown in Fig. 13.28 and are summarized as follows:

**1. When  $e = M/P < L/6$ , the soil pressure is trapezoidal:**

$$q_{\max} = \frac{P}{A} + \frac{Mc}{I} = \frac{P}{LB} + \frac{6M}{BL^2} \quad (13.21)$$

$$q_{\min} = \frac{P}{A} - \frac{Mc}{I} = \frac{P}{LB} - \frac{6M}{BL^2} \quad (13.22)$$

**2. When  $e = M/P = L/6$ , the soil pressure is triangular:**

$$q_{\max} = \frac{P}{LB} + \frac{6M}{BL^2} = \frac{2P}{LB} \quad (13.23)$$

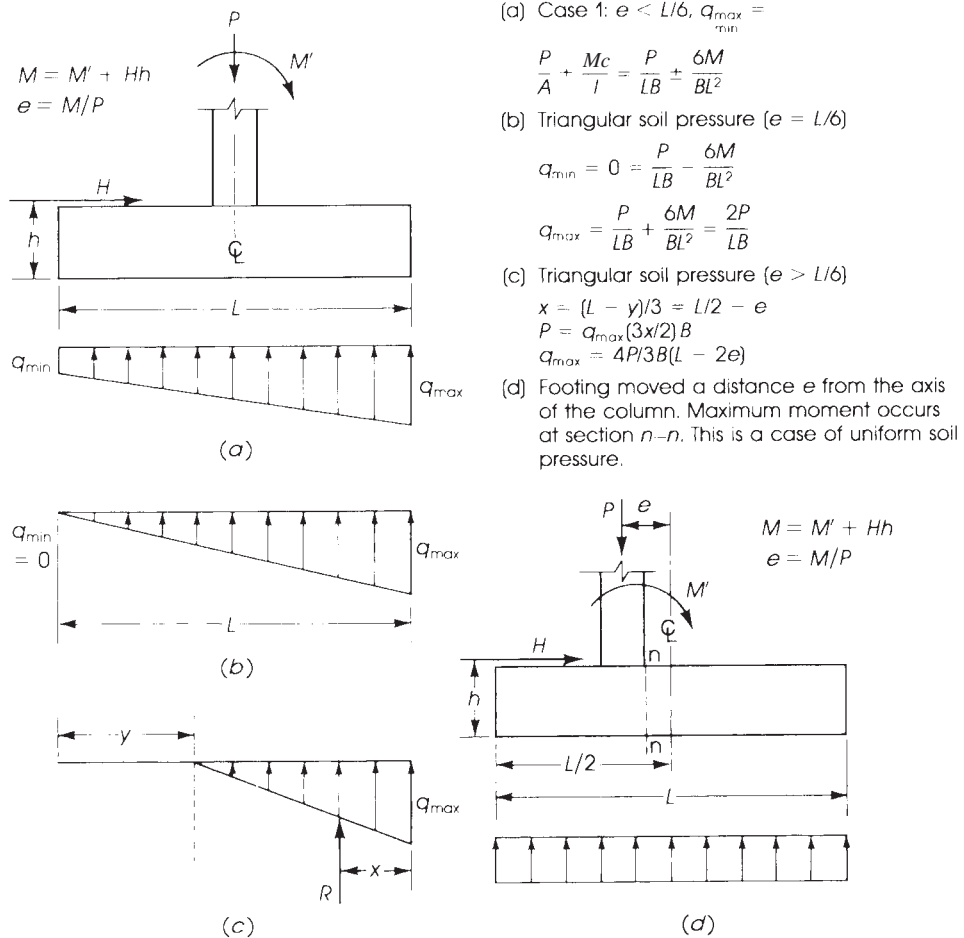
$$q_{\min} = 0 = \frac{P}{LB} - \frac{6M}{BL^2} \quad \text{or} \quad \frac{P}{LB} = \frac{6M}{BL^2} \quad (13.24)$$

**3. When  $e > L/6$ , the soil pressure is triangular:**

$$x = \frac{L - y}{3} = \frac{L}{2} - e$$

$$P = q_{\max} \left( \frac{3x}{2} \right) B \quad (13.25)$$

$$q_{\max} = \frac{2P}{3xB} = \frac{4P}{3B(L - 2e)}$$



**Figure 13.28** Single footing subjected to eccentric loading:  $L$  = length of footing,  $B$  = width, and  $h$  = height.

4. When the footing is moved a distance  $e$  from the axis of the column to produce uniform soil pressure under the footing: Maximum moment occurs at section  $n-n$ :

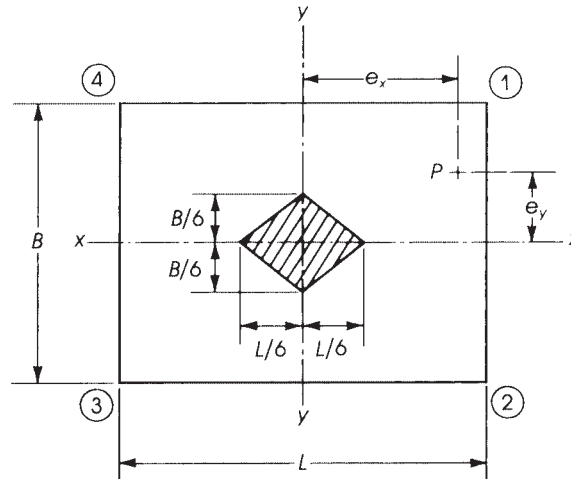
$$M = M' - Hh \quad \text{and} \quad e = \frac{M}{P}$$

### 13.8 FOOTINGS UNDER BIAxIAL MOMENT

In some cases, a footing may be subjected to an axial force and biaxial moments about its  $x$  and  $y$  axes; such a footing may be needed for a factory crane that rotates  $360^\circ$ . The footing then must be designed for the critical loading.

Referring to Fig. 13.29, if the axial load  $P$  acts at a distance  $e_x$  from the  $y$  axis and  $e_y$  from the  $x$  axis, then

$$M_x = Pe_y \quad \text{and} \quad M_y = Pe_x$$



**Figure 13.29** Footing subjected to  $P$  and biaxial moment. If  $e_x < L/6$  and  $e_y < B/6$ , footing will be subjected to upward soil pressure on all bottom surface (nonuniform pressure).

The soil pressure at corner 1 is

$$q_{\max} = \frac{P}{A} + \frac{M_x c_y}{I_x} + \frac{M_y c_x}{I_y}$$

At corner 2,

$$q_2 = \frac{P}{A} - \frac{M_x c_y}{I_x} + \frac{M_y c_x}{I_y}$$

At corner 3,

$$q_3 = \frac{P}{A} - \frac{M_x c_y}{I_x} - \frac{M_y c_x}{I_y}$$

At corner 4,

$$q_4 = \frac{P}{A} + \frac{M_x c_y}{I_x} - \frac{M_y c_x}{I_y}$$

Again, note that the allowable soil pressure must not be exceeded and the soil cannot take any tension; that is,  $q \geq 0$ .

### Example 13.8

A  $12 \times 24$ -in. column of an unsymmetrical shed shown in Fig. 13.30a is subjected to an axial load  $P_D = 220$  K and a moment  $M_d = 180$  K · ft due to dead load and an axial load  $P_L = 165$  K and a moment  $M_L = 140$  K · ft due to live load. The base of the footing is 5 ft below final grade, and the allowable soil bearing pressure is 5 ksf. Design the footing using  $f'_c = 4$  ksi and  $f_y = 60$  ksi.

### Solution

The footing is subjected to an axial load and a moment:

$$P = 220 + 165 = 385 \text{ K}$$

$$M = 180 + 140 = 320 \text{ K} \cdot \text{ft}$$

The eccentricity is

$$e = \frac{M}{P} = \frac{320 \times 12}{385} = 9.97 \text{ in.} \quad \text{say, } 10 \text{ in.}$$

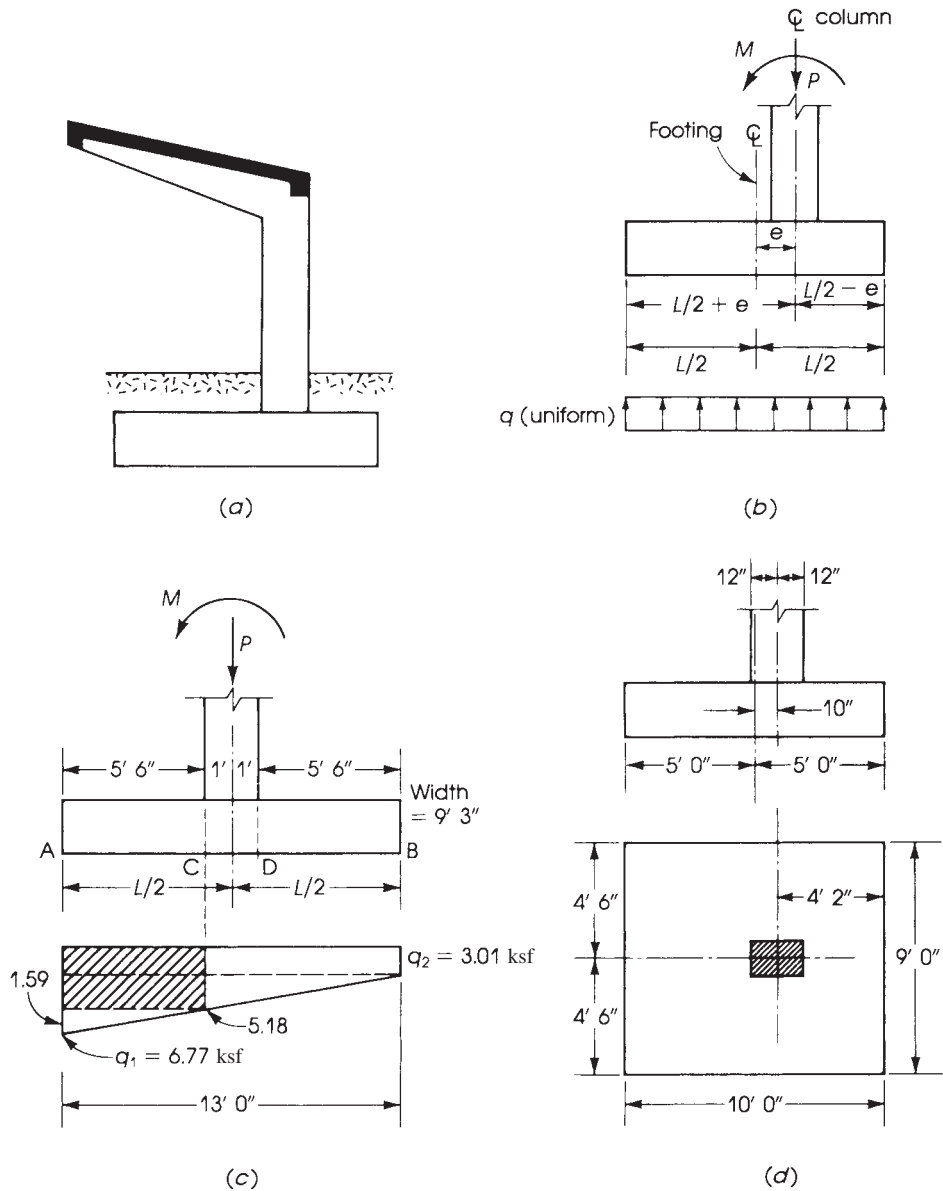


Figure 13.30 Example 13.7.

The footing may be designed by two methods.

*Method 1:* Move the center of the footing a distance  $e = 10$  in. from the center of the column. In this case, the soil pressure will be considered uniformly distributed under the footing (Fig. 13.30b).

*Method 2:* The footing is placed concentric with the center of the column. In this case, the soil pressure will be trapezoidal or triangular (Fig. 13.30c), and the maximum and minimum values can be calculated as shown in Fig. 13.30.

The application of the two methods to Example 13.8 can be explained briefly as follows:

1. For the first method, assume a footing depth of 20 in. ( $d = 16.5$  in.) and assume the weight of soil is 100 pcf. Net upward pressure is

$$5000 - \frac{20}{12} \times 150 \text{ (footing)} - \left(5 - \frac{20}{12}\right) \times 100 = 4417 \text{ psf}$$

$$\text{Area of footing} = \frac{385}{4.42} = 87.1 \text{ ft}^2$$

Assume a footing width of 9 ft; then the footing length is  $87.1/9 = 9.7$  ft, say, 10 ft. Choose a footing  $9 \times 10$  ft and place the column eccentrically, as shown in Fig. 13.27*d*. The center of the footing is 10 in. away from the center of the column.

2. The design procedure now is similar to that for a single footing. Check the depth for two-way and one-way shear action. Determine the bending moment at the face of the column for the longitudinal and transverse directions. Due to the eccentricity of the footing, the critical section will be on the left face of the column in Fig. 13.30*d*. The distance to the end of footing is  $(5 \times 12) - 2 = 58$  in. = 4.833 ft.

$$P_u = 1.2D + 1.6L = 1.2 \times 200 + 1.6 \times 165 = 504 \text{ K}$$

$$q_u = \frac{504}{9 \times 10} = 5.6 \text{ ksf}$$

$$\text{Maximum } M_u = (5.6 \times 9) \times \frac{(4.833)^2}{2} = 588.6 \text{ K} \cdot \text{ft} \quad (\text{in } 9\text{-ft width})$$

In the transverse direction,

$$M_u = (5.6 \times 10) \times \frac{(4)^2}{2} = 448 \text{ K} \cdot \text{ft}$$

Revise the assumed depth if needed and choose the required reinforcement in both directions of the footing, as was explained in the single-footing example.

3. For the second method, calculate the area of the footing in the same way as explained in the first method; then calculate the maximum soil pressure and compare it with that allowable using actual loads:

$$\text{Total load } P = 385 \text{ K}$$

$$\text{Size of footing} = 10 \times 9 \text{ ft}$$

Because the eccentricity is  $e = 10$  in.  $< L/6 \times \frac{12}{6} = 20$  in., the shape of the upward soil pressure is trapezoidal. Calculate the maximum and minimum soil pressure:

$$q_{\max} = \frac{P}{LB} + \frac{6M}{BL^2} = \frac{385}{10 \times 9} + \frac{6 \times 320}{9(10)^2} = 6.42 \text{ ksf} > 4.42 \text{ ksf}$$

The footing is not safe. Try a footing  $9.25 \times 13$  ft (area = 120.25 ft<sup>2</sup>).

$$q_{\max} = \frac{385}{120.25} + \frac{6 \times 320}{9.25(13)^2} = 4.22 \text{ ksf} < 4.42 \text{ ksf}$$

$$q_{\min} = 3.2 - 1.22 = 1.98 \text{ ksf}$$

4. Calculate the factored upward pressure using factored loads; then calculate moments and shears, as explained in previous examples.

### 13.9 SLABS ON GROUND

A mat foundation would be used when buildings are founded on soft and irregular soil, where pile foundation cannot be used.

A concrete slab laid directly on ground may be subjected to

1. Uniform load over its surface, producing small internal forces.
2. Nonuniform or concentrated loads, producing some moments and shearing forces. Tensile stresses develop, and cracks will occur in some parts of the slab.

Tensile stresses are generally induced by a combination of

1. Contraction due to temperature and shrinkage, restricted by the friction between the slab and the subgrade, causing tensile stresses.
2. Warping of the slab.
3. Loading conditions.
4. Settlement.

Contraction joints may be formed to reduce the tensile stresses in the slab. Expansion joints may be provided in thin slabs up to a thickness of 10 in.

Basement floors in residential structures may be made of 4 to 6-in. concrete slabs reinforced in both directions with a wire fabric reinforcement. In warehouses, slabs may be 6 to 12 in. thick, depending on the loading on the slab. Reinforcement in both directions must be provided, usually in the form of wire fabric reinforcement. Basement floors are designed to resist upward earth pressure and any water pressure. If the slab rests on very stable or incompressible soils, then differential settlement is negligible. In this case the slab thickness will be a minimum if no water table exists. Columns in the basement will have independent footings. If there is any appreciable differential settlement, the floor slab must be designed as a stiff raft foundation.

### 13.10 FOOTINGS ON PILES

When the ground consists of soft material for a great depth, and its bearing capacity is very low, it is not advisable to place the footings directly on the soil. It may be better to transmit the loads through piles to a deep stratum that is strong enough to bear the loads or to develop sufficient friction around the surface of the piles.

Many different kinds of piles are used for foundations. The choice depends on ground conditions, presence of groundwater, function of the pile, and cost. Piles may be made of concrete, steel, or timber.

In general, a pile cap (or footing) is necessary to distribute the load from a column to the heads of a number of piles. The cap should be of sufficient size to accommodate deviation in the position of the pile heads. The caps are designed as beams spanning between the pile heads and carrying concentrated loads from columns. When the column is supported by two piles, the cap may be designed as a reinforced concrete truss of a triangular shape.

The ACI Code, Section 13.4.2.2, indicates that computations for moments and shears for footings on piles may be based on the assumption that the reaction from any pile is concentrated at the pile center. The base area of the footing or number of piles shall be determined from the unfactored forces and moments.

The minimum concrete thickness above the reinforcement in a pile footing is limited to 12 in. (ACI Code, Section 13.4.2.1). For more design details of piles and pile footings, refer to books on foundation engineering.

### 13.11 SI EQUATIONS

1. One-way shear:

$$\phi V_c = 0.17\lambda\phi\sqrt{f'_c}bd \quad (\text{Eq. 13.3})$$

2. Two-way shear:

$$V_{c1} = 0.33\lambda\sqrt{f'_c}b_0d \quad (\text{Eq. 13.6})$$

$$V_{c2} = 0.17\left(1 + \frac{2}{\beta}\right)\lambda\sqrt{f'_c}b_0d \quad (\text{Eq. 13.7})$$

$$V_{c3} = 0.083\left(\frac{\alpha_s d}{b_o} + 2\right)\lambda\sqrt{f'_c}b_0d \quad (\text{Eq. 13.8})$$

Other equations remain the same.

### SUMMARY

#### Sections 13.1–13.4

1. *General:*

$H$  = distance of bottom of footing from final grade (ft)

$h$  = total depth of footing (in.)

$c$  = wall thickness (in.)

$q_a$  = allowable soil pressure (ksf)

$q_e$  = effective soil pressure

$W_s$  = weight of soil (pcf)(Assume 100 pcf if not given.)

2. *Design of Wall Footings.* The design steps can be summarized as follows:

a. Assume a total depth of footing  $h$  (in.). Consider 1-ft length of footing.

b. Calculate  $q_e = q_a - (h/12)(150) - W_s(H - h/12)$  ( $q_a$  in psf).

c. Calculate width of footing:  $B = (\text{total service load})/q_e = (P_D + P_n)/q_e$ . (Round to the nearest higher half foot.) The footing size is  $(B \times 1)$  ft.

d. Calculate the factored upward pressure,  $q_u = P_u/B$  where  $P_u = 1.2P_D + 1.6P_L$ .

e. Check the assumed depth for one-way shear requirements considering  $d_a = (h - 3.5 \text{ in.})$  (Two-way shear does not apply.)

$$V_u = q_u \left( \frac{B}{2} - d - \frac{c}{2} \right) \quad (\text{use kips.})$$



$$\text{Required } d = \frac{V_u(1000)}{\phi(2\lambda\sqrt{f'_c})(12)} \geq d_a$$

- f. Calculate the bending moment and main steel. The critical section is at the face of the wall.
- i.  $M_u = 0.5q_u(L/2 - c/2)^2$ ; get  $R_u = M_u/bd^2$ .
  - ii. Determine  $\rho$  from tables in Appendix A or from Eq. 13.14.
  - iii.  $A_s = \rho bd = 12 \rho d$  in.<sup>2</sup>/ft;  $A_s \geq A_{s \min}$ .
  - iv. Minimum steel for shrinkage is

$$A_{sh} = \begin{cases} 0.0018(bh) & \text{for } f_y = 60 \text{ ksi} \\ 0.0020(bh) & \text{for } f_y = 40,50 \text{ ksi} \end{cases}$$

Minimum steel for flexure is

$$A_{sf} = \begin{cases} \left(\frac{200}{f_y}\right) bd = \left(\frac{200}{f_y}\right) (12d) & \text{when } f'_c < 4500 \text{ psi} \\ \frac{(3\sqrt{f'_c})(12d)}{f_y} & \text{when } f'_c > 4500 \text{ psi} \end{cases}$$

where  $A_s$  calculated must be greater than  $A_{sh}$  (shrinkage). However, if  $A_s < A_{sf}$ , it is recommended to use  $A_s = A_{sf}$  and then choose bars and spacings.

- g. Check development length: Refer to Tables 7.1 to 7.4.
  - h. Calculate secondary reinforcement in the direction of the wall.  $A_s = A_{sh}$  as calculated in step f using  $b = 12$  in. Choose bars and spacings.
3. *Design of Square/Rectangular Footings.* The design steps are as follows:
- a. Assume a total depth  $h$  (in.); let  $d_a$  (assumed) =  $h - 4.5$  in. Calculate  $q_e = q_a - (h/12)(150) - W_s(H - h/12)$ . (Use psf.)
  - b. Calculate the area of the footing,  $AF = (P_D + P_L)/q_e$ . Choose either a square footing, side =  $\sqrt{AF}$ , or a rectangular footing of length  $L$  and width  $B$  (short length); then round dimensions to the higher half foot.
  - c. Calculate  $q_u = P_u/(LB)$ .
  - d. Check footing depth due to two-way shear first. Maximum  $V_{u2}$  occurs at a section located at a distance equal to  $d/2$  around the column.
    - i. Calculate  $b_0 = 4(c + d)$  for square columns and  $b_0 = 2(c_1 + d) + 2(c_2 + d)$  for rectangular columns:

$$V_{u2} = \begin{cases} P_u - q_u(c + d)^2 & \text{for square columns} \\ P_u - q_u(c_1 + d)(c_2 + d) & \text{for rectangular columns} \end{cases}$$

- ii. Calculate  $d_1 = V_{u2}/4\phi\lambda\sqrt{f'_c}b_0$  when  $\beta = L/B \leq 2$ .

$$d_1 = \frac{V_{u2}}{\phi(2 + 4/\beta)\lambda\sqrt{f'_c}b_0} \quad \text{when } \beta > 2$$

- iii. Calculate

$$d_2 = \frac{V_{u2}}{\phi(\alpha_s d/b_0 + 2)\lambda\sqrt{f'_c}b_0}$$

Let  $d$  be the larger of  $d_1$  and  $d_2$ . If  $d$  is less than  $d_a$  (assumed), increase  $d_a$  (or  $h$ ) and repeat. The required  $d$  should be close to the assumed  $d_a$  (within 5% or 1 in. higher).

- e. Check one-way shear (normally does not control in single footings):

- i.  $V_{u_{11}} = q_u B(L/2 - c/2 - d)$  in the long direction (or for square footings):

$$d_{11} = \frac{V_{u_{11}}}{2\phi\lambda\sqrt{f'_c}B}$$

- ii.  $V_{u_{12}} = q_u L(B/2 - c/2 - d)$  in the short direction:

$$d_{12} = \frac{V_{u_{12}}}{2\phi\lambda\sqrt{f'_c}L} \quad (\text{for rectangular footings})$$

- iii. Let  $d$  be the larger of  $d_{11}$  and  $d_{12}$ ; then use the larger  $d$  from steps iv and v.  
 iv. Determine  $h = (d + 4.5)$  in.; round to the nearest higher inch.  
 v. Calculate the final  $d = (h - 4.5)$  in.  
 f. Calculate the bending moment and the main steel in one direction only for square footings and two directions for rectangular footings.

- i. In the long direction (or for square footings)

$$M_{uL} = 0.5q_u \left( \frac{L}{2} - \frac{c}{2} \right)^2 \quad R_u = \frac{M_{uL}}{Bd^2}$$

- ii. In the short direction (for rectangular footings):

$$M_{us} = 0.5q_u \left( \frac{B}{2} - \frac{c}{2} \right)^2 \quad R_{us} = \frac{M_{us}}{Ld^2}$$

- iii. Calculate the reinforcement in the long direction,  $A_{sL}$ , and in the short direction,  $A_{ss}$ , using Eq. 13.14.  
 iv. Check that  $A_{sL}$  and  $A_{ss}$  are greater than the minimum steel reinforcement. Choose bars and spacings. For square footings, the same bars are used in both directions. Distribute bars in the bandwidth of rectangular columns according to Eq. 13.15.  
 g. Check bearing stress:  
 i. Calculate  $N_1$  and  $N_2$ :  $N_1\phi(0.85f'_cA_1)$ , where  $\phi$  is 0.65 and  $A_1$  is the area of column section;  $N_2 = N_1\sqrt{A_2/A_1} \leq 2N_1$ , where  $A_2$  is the square area of footing under column ( $A_2 = B^2$ ).  
 ii. If  $P_u \leq N_1$ , bearing stress is adequate. Minimum area of dowels is  $0.005A_1$ . Choose four bars to be placed at the four corners of the column section.  
 iii. If  $P_u > N_1$ , determine the excess load,  $P_{ex} = (P_u - N_1)$ , and then calculate  $A_{sd}$  (dowels)  $= P_{ex}/f_y$ ;  $A_{sd}$  must be equal to or greater than  $0.005A_1$ . Choose at least four dowel bars.  
 iv. Determine the development length in compression for dowels in the column and in the footing.  
 h. Calculate the development lengths,  $l_d$ , of the main bars in the footings. The calculated  $l_d$  must be greater than or equal to  $l_d$  provided in the footing. Provided  $l_d = L/2 - c/2 - 3$  in. in the long direction and  $l_d = B/2 - c/2 - 3$  in the short direction. Examples 13.2 and 13.3 explain these steps.

**Section 13.5**

Plain concrete may be used to support walls. The maximum flexural stress in tension should be calculated and must be less than the allowable stress of  $5\phi\sqrt{f'_c}$ .

**Section 13.6**

A combined footing is used when a column is located near a property line. Design of such footings is explained in Example 13.7.

**Sections 13.7–13.9**

Footings under eccentric column loads are explained in Example 13.8.

**REFERENCES**

1. R. W. Furlong. "Design Aids for Square Footings." *ACI Journal* 62 (March 1965): 363–372.
2. R. Peck, W. Hanson, and T. Thornburn. *Foundation Engineering*, 2nd ed. Wiley, New York, 1974.
3. ACI Committee 436. "Suggested Design Procedures for Combined Footings and Mats." *ACI Journal* 63 (October 1966): 1041–1058.
4. F. Kramrisch and P. Rogers. "Simplified Design of Combined Footings." *Journal of Soil Mechanics and Foundation Division, ASCE* 85 (October 1961).
5. L. S. Blake (ed.). *Civil Engineer's Reference Book*, 3rd ed. Butterworths, London, 1975.
6. American Concrete Institute (ACI). *Building Code Requirements for Structural Concrete*. ACI Code 318–14. ACI Detroit, MI, 2014.

**PROBLEMS**

For all problems in this chapter, use the following:

$H_a$  = distance from bottom of footing to final grade

$h$  = depth of concrete footing

$q_a$  = allowable soil pressure in ksf

Assume the weight of the soil is 100 pcf and  $f_y = 60$  ksi.

- 13.1 For each problem in Table 13.1, design a wall footing to support the given reinforced concrete wall loads. Design for shear and moment; check the development length requirements. Also, determine the footing bars and their distribution. (Assume  $d = h - 3.5$  in.)
- 13.2 For each problem in Table 13.2, design a square single footing to support the given square and round column loads. Design for moments, shear, load transfer, dowel length, and development lengths for footing main bars. Choose adequate bars and spacings. (Assume  $d = h - 4.5$  in. for all problems.)
- 13.3 Repeat Problem 13.2a–h using rectangular footings with widths of 6, 6, 8, 8, 7, 8, 6, and 9 ft, respectively.
- 13.4 Repeat Problem 13.2a–d using rectangular columns of  $14 \times 20$  in.,  $16 \times 20$  in.,  $16 \times 24$  in., and  $12 \times 18$  in., respectively, and rectangular footings with the length equal to about 1.5 times the width.
- 13.5 Repeat Problem 13.1a–d using plain concrete wall footings and one-half the applied dead and live loads.

Table 13.1 Problem 13.1

Number	Wall Thickness (in.)	Dead Load (K/ft)	Live Load (K/ft)	$f'_c$ (Ksi)	$q_a$ (Ksf)	$H$ (ft)	Part Answers	
							$L$ (ft)	$H$ (in.)
a	12	22	12	3	4	5	10	19
b	12	18	14	3	5	4	7.5	17
c	14	28	16	3	6	6	8.5	20
d	14	26	24	3	4	5	14.5	27
e	16	32	16	3	5	5	11	23
f	16	24	20	4	6	8	9	19
g	14	20	18	4	4	6	11.5	19
h	14	28	20	4	5	4	10.5	21
i	12	18	14	4	6	5	6	14
j	14	16	20	4	6	5	7	16

Table 13.2 Problem 13.2

Number	Column (in.)	Column bars	Dead Load (K)	Live Load (K)	$f'_c$ (Ksi)	$q_s$ (Ksf)	$H$ (ft)	Part Answers	
								$L$ (ft)	$H$ (in.)
a	16 × 16	8 no. 8	150	115	3	5	6	8	20
b	18 × 18	8 no. 9	160	100	3	6	5	7	19
c	20 × 20	12 no. 9	245	159	3	6	7	9	23
d	12 × 12	8 no. 8	180	140	3	5	8	9	24
e	14 × 14	8 no. 9	140	160	4	5	6	8.5	21
f	16 × 16	8 no. 9	190	140	4	4	5	10	21
g	18 × 18	12 no. 8	200	120	4	6	7	8	20
h	20 × 20	12 no. 9	195	195	4	5	8	10	22
i	Dia. 20	8 no. 9	120	85	4	5	5	7	16
j	Dia. 16	8 no. 8	110	90	3	4	6	8	18

- 13.6** Design a rectangular combined footing to support the two columns shown in Fig. 13.31. The center of the exterior column is 1 ft away from the property line and 14 ft from the center of the interior column. The exterior column is square with 18-in. sides, is reinforced with no. 8 bars, and carries an axial dead load of 160 K and a live load of 140 K. The interior column is square with 20-in. sides, is reinforced with no. 9 bars, and carries an axial dead load of 240 K and a live load of 150 K. The bottom of the footing is 5 ft below final grade. Use  $f'_c = 4$  ksi,  $f_y = 60$  ksi, and an allowable soil pressure of 5 ksf.

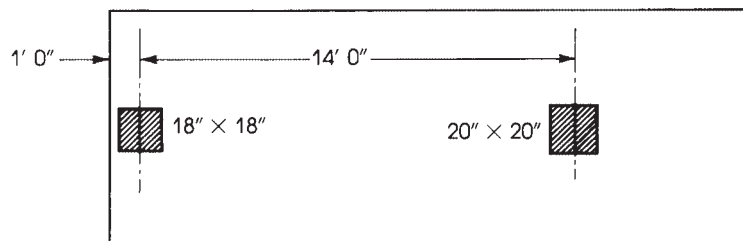
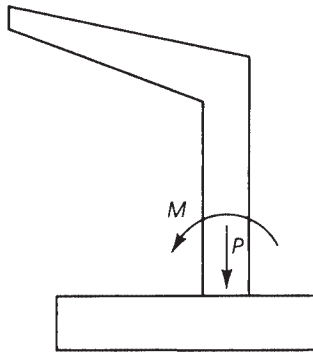


Figure 13.31 Problem 13.6.

**Table 13.3** Problem 13.7

	Footing 1	Footing 2	Footing 3	Footing 4	Footing 5	Footing 6
Dead load	130 K	220 K	150 K	180 K	200 K	240 K
Live load	160 K	220 K	210 K	180 K	220 K	200 K

- 13.7** Determine the footing areas required for a balanced footing design (equal settlement approach) if the usual load is 25% for all footings. The allowable soil pressure is 5 ksi and the dead and live loads are given in Table 13.3.
- 13.8** The  $12 \times 20$ -in. ( $300 \times 500$ -mm) column of the frame shown in Fig. 13.32 is subjected to an axial load  $P_D = 200$  K and a moment  $M_D = 120$  K · ft due to dead load and an axial load  $P_L = 160$  K and a moment  $M_L = 110$  K · ft due to live load. The base of the footing is 4 ft below final grade. Design the footing using  $f'_c = 4$  ksi,  $f_y = 40$  ksi, and an allowable soil pressure of 4 ksi. Use a uniform pressure and eccentric footing approach.

**Figure 13.32** Problem 13.8.

- 13.9** Repeat Problem 13.8 if both the column and the footing have the same centerline (concentric case).
- 13.10** Determine the size of a square or round footing for the case of Problem 13.9, assuming that the loads and moments on the footing are for a rotating crane fixed at its base.

# CHAPTER 14

## RETAINING WALLS



Apartment building, Miami, Florida.

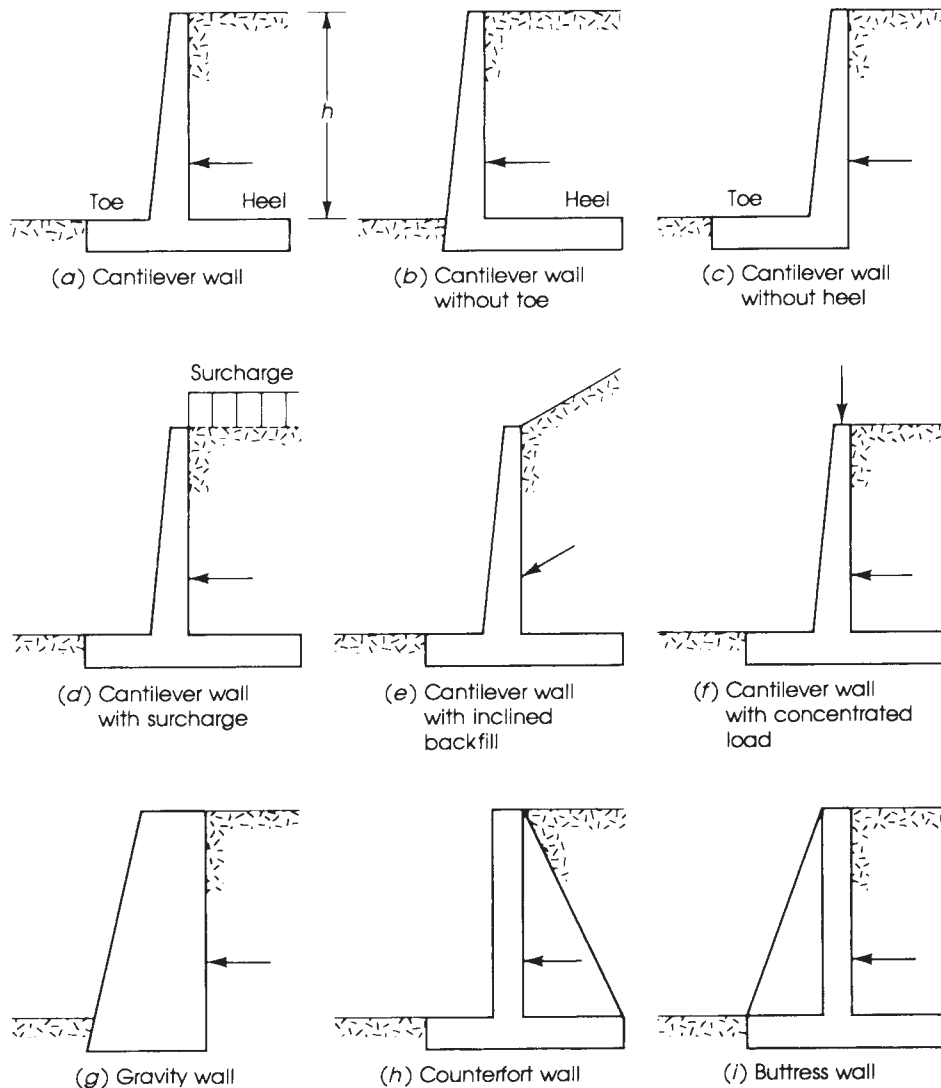
### 14.1 INTRODUCTION

Retaining walls are structural members used to provide stability for soil or other materials and to prevent them from assuming their natural slope. In this sense, the retaining wall maintains unequal levels of earth on its two faces. The retained material on the higher level exerts a force on the retaining wall that may cause its overturning or failure. Retaining walls are used in bridges as abutments, in buildings as basement walls, and in embankments. They are also used to retain liquids, as in water tanks and sewage treatment tanks.

### 14.2 TYPES OF RETAINING WALLS

Retaining walls may be classified as follows (refer to Fig. 14.1):

1. *Gravity walls* usually consist of plain concrete or masonry and depend entirely on their own weight to provide stability against the thrust of the retained material. These walls are proportioned so that tensile stresses do not develop in the concrete or masonry due to the exerted forces on the wall. The practical height of a gravity wall does not exceed 10 ft.
2. *Semigravity walls* are gravity walls that have a wider base to improve the stability of the wall and to prevent the development of tensile stresses in the base. Light reinforcement is sometimes used in the base or stem to reduce the large section of the wall.
3. The *cantilever retaining wall* is a reinforced concrete wall that is generally used for heights from 8 to 20 ft. It is the most common type of retaining structure because of economy and simplicity of construction. Various types of cantilever retaining walls are shown in Fig. 14.1.
4. *Counterfort retaining walls* higher than 20 ft develop a relatively large bending moment at the base of the stem, which makes the design of such walls uneconomical. One solution in this case is to introduce transverse walls (or counterforts) that tie the stem and the base together at intervals. The counterforts act as tension ties supporting the vertical walls. Economy is



**Figure 14.1** Types of retaining walls.

achieved because the stem is designed as a continuous slab spanning horizontally between counterforts, whereas the heel is designed as a slab supported on three sides (Fig. 14.1*h*).

5. The *buttressed retaining wall* is similar to the counterfort wall, but in this case the transverse walls are located on the opposite, visible side of the stem and act in compression (Fig. 14.1*i*). The design of such walls becomes economical for heights greater than 20 ft. They are not popular because of the exposed buttresses.
6. *Bridge abutments* are retaining walls that are supported at the top by the bridge deck. The wall may be assumed fixed at the base and simply supported at the top.
7. *Basement walls* resist earth pressure from one side of the wall and span vertically from the basement-floor slab to the first-floor slab. The wall may be assumed fixed at the base and simply supported or partially restrained at the top.

### 14.3 FORCES ON RETAINING WALLS

Retaining walls are generally subjected to gravity loads and to earth pressure due to the retained material on the wall. Gravity loads due to the weights of the materials are well defined and can be calculated easily and directly. The magnitude and direction of the earth pressure on a retaining wall depends on the type and condition of soil retained and on other factors and cannot be determined as accurately as gravity loads. Several references on soil mechanics[1,2] explain the theories and procedure for determining the soil pressure on retaining walls. The stability of retaining walls and the effect of dynamic reaction on walls are discussed in Refs. 3 and 4.

Granular materials, such as sand, behave differently from cohesive materials, such as clay, or from any combination of both types of soils. Although the pressure intensity of soil on a retaining wall is complex, it is common to assume a linear pressure distribution on the wall. The pressure intensity increases with depth linearly, and its value is a function of the height of the wall and the weight and type of soil. The pressure intensity,  $p$ , at a depth  $h$  below the earth's surface may be calculated as follows:

$$p = Cwh \quad (14.1)$$

where  $w$  is the unit weight of soil and  $C$  is a coefficient that depends on the physical properties of soil. The value of the coefficient  $C$  varies from 0.3 for loose granular soil, such as sand, to about 1.0 for cohesive soil, such as wet clay. If the retaining wall is assumed absolutely rigid, a case of earth pressure at rest develops. Under soil pressure, the wall may deflect or move a small amount from the earth, and active soil pressure develops, as shown in Fig. 14.2. If the wall moves toward the soil, a passive soil pressure develops. Both the active and passive soil pressures are assumed to vary linearly with the depth of the wall (Fig. 14.2). For dry, granular, noncohesive materials, the assumed linear pressure diagram is fairly satisfactory; cohesive soils or saturated sands behave in a different, nonlinear manner. Therefore, it is very common to use granular materials as backfill to provide an approximately linear pressure diagram and also to provide for the release or drainage of water from behind the wall.

For a linear pressure, the active and passive pressure intensities are determined as follows:

$$P_a = C_a wh \quad (14.2)$$

$$P_p = C_p wh \quad (14.3)$$

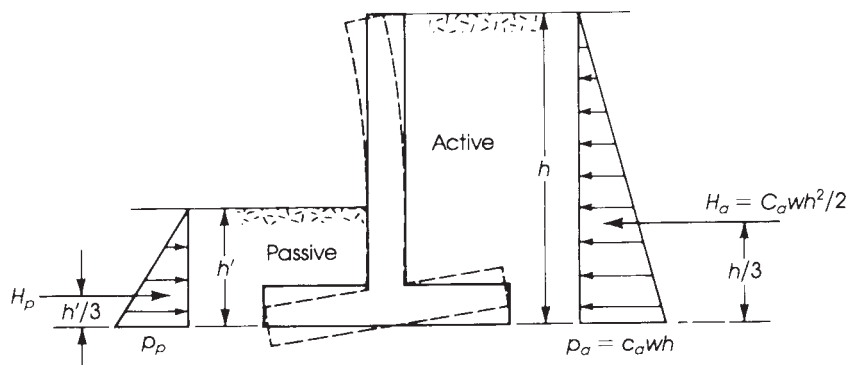


Figure 14.2 Active and passive earth pressure.



where  $C_a$  and  $C_p$  are the approximate coefficients of the active and passive pressures, respectively.

#### 14.4 ACTIVE AND PASSIVE SOIL PRESSURES

The two theories most commonly used in the calculation of earth pressure are those of Rankine and Coulomb [1,6].

1. In Rankine's approach, the retaining wall is assumed to yield a sufficient amount to develop a state of plastic equilibrium in the soil mass at the wall surface. The rest of the soil remains in the state of elastic equilibrium. The theory applies mainly to a homogeneous, incompressible, cohesionless soil and neglects the friction between soil and wall. The active soil pressure at a depth  $h$  on a retaining wall with a horizontal backfill based on Rankine's theory is determined as follows:

$$P_a = C_a wh = wh \left( \frac{1 - \sin \phi}{1 + \sin \phi} \right) \quad (14.4)$$

where

$$C_a = \left( \frac{1 - \sin \phi}{1 + \sin \phi} \right)$$

$\phi$  = angle of internal friction of the soil (Table 14.1)

and

$$\text{Total active pressure, } H_a = \frac{wh^2}{2} \left( \frac{1 - \sin \phi}{1 + \sin \phi} \right) \quad (14.5)$$

The resultant,  $H_a$ , acts at  $h/3$  from the base (Fig. 14.2). When the earth is surcharged at an angle  $\delta$  to the horizontal, then

$$C_a = \cos \delta \left( \frac{\cos \delta - \sqrt{\cos^2 \delta - \cos^2 \phi}}{\cos \delta + \sqrt{\cos^2 \delta - \cos^2 \phi}} \right)$$

$$P_a = C_a wh \quad \text{and} \quad H_a = C_a \frac{wh^2}{2} \quad (14.6)$$

**Table 14.1** Values of  $w$  and  $\phi$

Type of Backfill	Unit Weight, $W$		Angle of Internal Friction, $\phi$
	pcf	kg/m <sup>3</sup>	
Soft clay	90–120	1440–1920	0°–15°
Medium clay	100–120	1600–1920	15°–30°
Dry loose silt	100–120	1600–1920	27°–30°
Dry dense silt	110–120	1760–1920	30°–35°
Loose sand and gravel	100–130	1600–2100	30°–40°
Dense sand and gravel	120–130	1920–2100	25°–35°
Dry loose sand, graded	115–130	1840–2100	33°–35°
Dry dense sand, graded	120–130	1920–2100	42°–46°



Reinforced concrete retaining wall.



Retaining wall in a parking area.

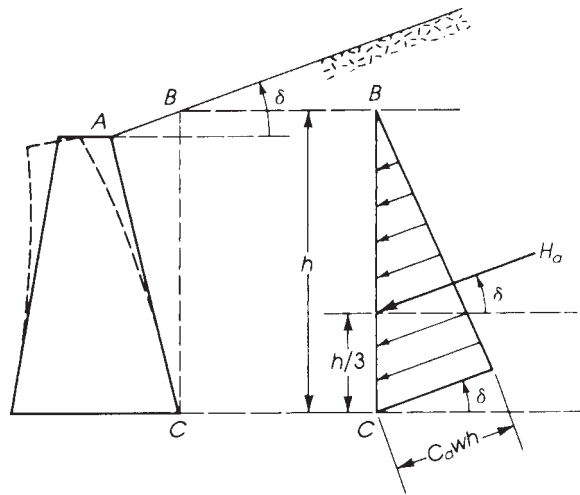


Figure 14.3 Active soil pressure with surcharge.

Table 14.2 Values of  $C_a$

$\delta$	$\phi = C_a$						
	$\phi = 28^\circ$	$\phi = 30^\circ$	$\phi = 32^\circ$	$\phi = 34^\circ$	$\phi = 36^\circ$	$\phi = 38^\circ$	$\phi = 40^\circ$
$0^\circ$	0.361	0.333	0.307	0.283	0.260	0.238	0.217
$10^\circ$	0.380	0.350	0.321	0.294	0.270	0.246	0.225
$20^\circ$	0.461	0.414	0.374	0.338	0.306	0.277	0.250
$25^\circ$	0.573	0.494	0.434	0.385	0.343	0.307	0.275
$30^\circ$	0	0.866	0.574	0.478	0.411	0.358	0.315

The resultant,  $H_a$ , acts at  $h/3$  and is inclined at an angle  $\delta$  to the horizontal (Fig. 14.3). The values of  $C_a$  expressed by Eq. 14.6 for different values of  $\delta$  and angle of internal friction  $\phi$  are shown in Table 14.2.

Passive soil pressure develops when the retaining wall moves against and compresses the soil. The passive soil pressure at a depth  $h$  on a retaining wall with horizontal backfill is determined as follows:

$$P_p = C_p wh = wh \left( \frac{1 + \sin \phi}{1 - \sin \phi} \right) \tag{14.7}$$

where

$$C_p = \left( \frac{1 + \sin \phi}{1 - \sin \phi} \right) = \frac{1}{C_a}$$

Total passive pressure is

$$H_p = \frac{wh^2}{2} \left( \frac{1 + \sin \phi}{1 - \sin \phi} \right) \tag{14.8}$$

The resultant,  $H_p$ , acts at  $h'/3$  from the base (Fig. 14.2). When the earth is surcharged at an angle  $\delta$  to the horizontal, then

$$C_p = \cos \delta \left( \frac{\cos \delta + \sqrt{\cos^2 \delta - \cos^2 \phi}}{\cos \delta - \sqrt{\cos^2 \delta - \cos^2 \phi}} \right)$$

$$P_p = C_p wh \quad \text{and} \quad H_p = C_p \frac{wh^2}{2} \quad (14.9)$$

In this case  $H_p$  acts at  $h'/3$  and is inclined at an angle  $\delta$  to the horizontal (Fig. 14.4). The values of  $C_p$  expressed by Eq. 14.9 for different values of  $\delta$  and  $\phi$  are shown in Table 14.3.

The values of  $\phi$  and  $w$  vary with the type of backfill used. As a guide, common values of  $\phi$  and  $w$  are given in Table 14.1.

2. In Coulomb's theory, the active soil pressure is assumed to be the result of the tendency of a wedge of soil to slide against the surface of a retaining wall. Hence, Coulomb's theory is referred to as the wedge theory. While it takes into consideration the friction of the soil on the retaining wall, it assumes that the surface of sliding is a plane, whereas in reality it is slightly curved. The error in this assumption is negligible in calculating the active soil pressure. Coulomb's equations to calculate the active and passive soil pressure are as follows:

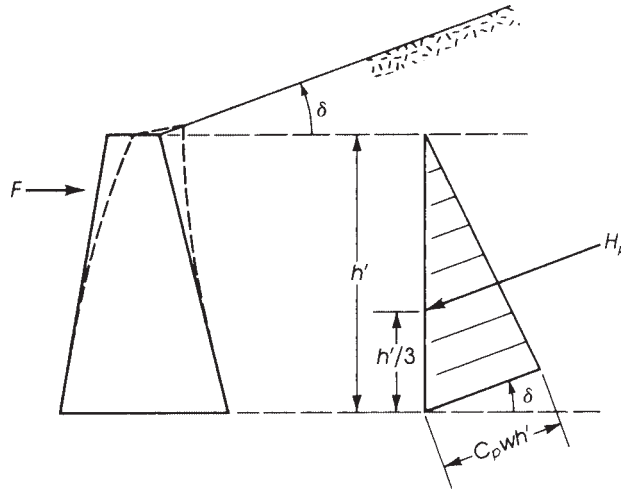


Figure 14.4 Passive soil pressure with surcharge.

Table 14.3 Values of  $C_p$

$\delta$	$\phi = C_p$						
	$\phi = 28^\circ$	$\phi = 30^\circ$	$\phi = 32^\circ$	$\phi = 34^\circ$	$\phi = 36^\circ$	$\phi = 38^\circ$	$\phi = 40^\circ$
$0^\circ$	2.77	3.00	3.25	3.54	3.85	4.20	4.60
$10^\circ$	2.55	2.78	3.02	3.30	3.60	3.94	4.32
$20^\circ$	1.92	2.13	2.36	2.61	2.89	3.19	3.53
$25^\circ$	1.43	1.66	1.90	2.14	2.40	2.68	3.00
$30^\circ$	0	0.87	1.31	1.57	1.83	2.10	2.38

The active soil pressure is

$$P_a = C_a wh$$

where

$$C_a = \frac{\cos^2(\phi - \theta)}{\cos^2 \theta \cos(\theta + \beta) \left[ 1 + \sqrt{\frac{\sin(\phi + \beta) \sin(\phi - \delta)}{\cos(\theta + \beta) \cos(\theta - \delta)}} \right]^2} \quad (14.10a)$$

where

$\phi$  = angle of internal friction of soil

$\theta$  = angle of soil pressure surface from vertical

$\beta$  = angle of friction along wall surface (angle between soil and concrete)

$\delta$  = angle of surcharge to horizontal

The total active soil pressure is

$$H_a = C_a \frac{wh^2}{2} = p_a \frac{h}{2}$$

When the wall surface is vertical,  $\theta = 0^\circ$ , and if  $\beta = \delta$ , then  $C_a$  in Eq. 14.10a reduces to Eq. 14.6 of Rankine.

Passive soil pressure is

$$P_p = C_p wh' \quad \text{and} \quad H_p = \left( \frac{wh'^2}{2} \right) C_p = P_p \frac{h'}{2}$$

where

$$C_p = \frac{\cos^2(\phi + \theta)}{\cos^2 \theta \cos(\theta - \beta) \left[ 1 - \sqrt{\frac{\sin(\phi + \beta) \sin(\phi + \delta)}{\cos(\theta - \beta) \cos(\theta - \delta)}} \right]^2} \quad (14.10b)$$

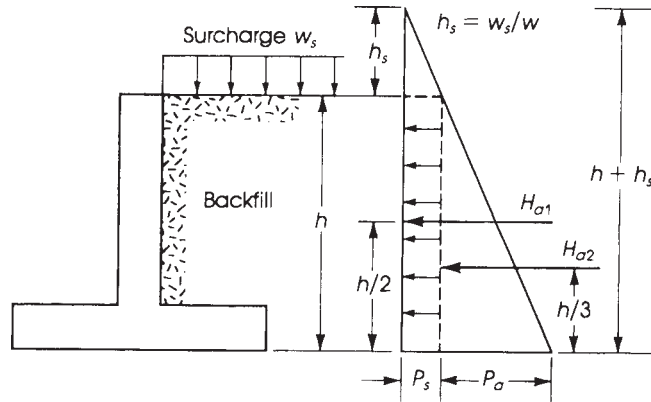
The values of  $\phi$  and  $w$  vary with the type of backfill used. As a guide, common values of  $\phi$  and  $w$  are given in Table 14.1.

3. When the soil is saturated, the pores of the permeable soil are filled with water, which exerts hydrostatic pressure. In this case the buoyed unit weight of soil must be used. The buoyed unit weight (or submerged unit weight) is a reduced unit weight of soil and equals  $w$  minus the weight of water displaced by the soil. The effect of the hydrostatic water pressure must be included in the design of retaining walls subjected to a high water table and submerged soil. The value of the angle of internal friction may be used, as shown in Table 14.1.

## 14.5 EFFECT OF SURCHARGE

Different types of loads are often imposed on the surface of the backfill behind a retaining wall. If the load is uniform, an equivalent height of soil,  $h_s$ , may be assumed acting on the wall to account for the increased pressure. For the wall shown in Fig. 14.5, the horizontal pressure due to the surcharge is constant throughout the depth of the retaining wall.

$$h_s = \frac{w_s}{w} \quad (14.11)$$



**Figure 14.5** Surcharge effect under a uniform load.

where

- $h_s$  = equivalent height of soil (ft)
- $w_s$  = pressure of the surcharge (psf)
- $w$  = unit weight of soil (pcf)

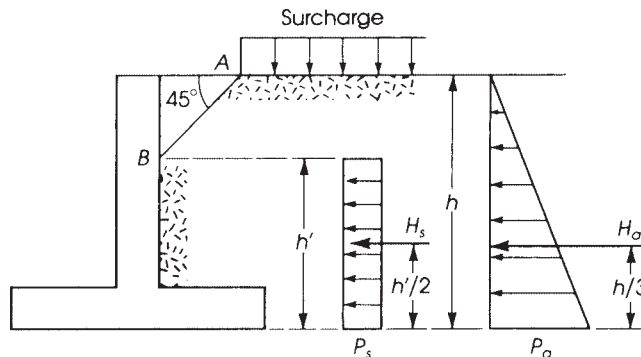
The total pressure is

$$H_a = H_{a1} + H_{a2} = C_a w \left( \frac{h^2}{2} + h h_s \right) \tag{14.12}$$

In the case of partial uniform load acting at a distance from the wall, only a portion of the total surcharge pressure affects the wall (Fig. 14.6).

It is common practice to assume that the effective height of pressure due to partial surcharge is  $h'$ , measured from point  $B$  to the base of the retaining wall [1]. The line  $AB$  forms an angle of  $45^\circ$  with the horizontal.

In the case of wheel load acting at a distance from the wall, the load is to be distributed over a specific area, which is usually defined by known specifications such as AASHTO and AREA [4] specifications.



**Figure 14.6** Surcharge effect under a partial uniform load at a distance from the wall.

### 14.6 FRICTION ON THE RETAINING WALL BASE

The horizontal component of all forces acting on a retaining wall tends to push the wall in a horizontal direction. The retaining wall base must be wide enough to resist the sliding of the wall. The coefficient of friction to be used is that of soil on concrete for coarse granular soils and the shear strength of cohesive soils [4]. The coefficients of friction  $\mu$  that may be adopted for different types of soil are as follows:

- Coarse-grained soils without silt,  $\mu = 0.55$
- Coarse-grained soils with silt,  $\mu = 0.45$
- Silt,  $\mu = 0.35$
- Sound rock,  $\mu = 0.60$

The total frictional force,  $F$ , on the base to resist the sliding effect is

$$F = \mu R + H_p \quad (14.13)$$

where

- $\mu$  = coefficient of friction
- $R$  = vertical force acting on base
- $H_p$  = passive resisting force

The factor of safety against sliding is

$$\text{Factor of safety} = \frac{F}{H_{ah}} = \frac{\mu R + H_p}{H_{ah}} \geq 1.5 \quad (14.14)$$

where  $H_{ah}$  is the horizontal component of the active pressure,  $H_a$ . The factor of safety against sliding should not be less than 1.5 if the passive resistance  $H_p$  is neglected and should not be less than 2.0 if  $H_p$  is taken into consideration.

### 14.7 STABILITY AGAINST OVERTURNING

The horizontal component of the active pressure,  $H_a$ , tends to overturn the retaining wall about the point zero on the toe (Fig. 14.7). The overturning moment is equal to  $M_0 = H_a h/3$ . The weight of the concrete and soil tends to develop a balancing moment, or righting moment, to resist the overturning moment. The balancing moment for the case of the wall shown in Fig. 14.7 is equal to

$$M_b = w_1 x_1 + w_2 x_2 + w_3 x_3 = \sum wx$$

The factor of safety against overturning is

$$\frac{M_b}{M_0} = \frac{\sum wx}{H_a h/3} \geq 2.0 \quad (14.15)$$

This factor of safety should not be less than 2.0.

The resultant of all forces acting on the retaining wall,  $R_A$ , intersects the base at point  $C$  (Fig. 14.7). In general, point  $C$  does not coincide with the center of the base,  $L$ , thus causing eccentric loading on the footing. It is desirable to keep point  $C$  within the middle third to get the whole footing under soil pressure. (The case of a footing under eccentric load was discussed in Chapter 13.)

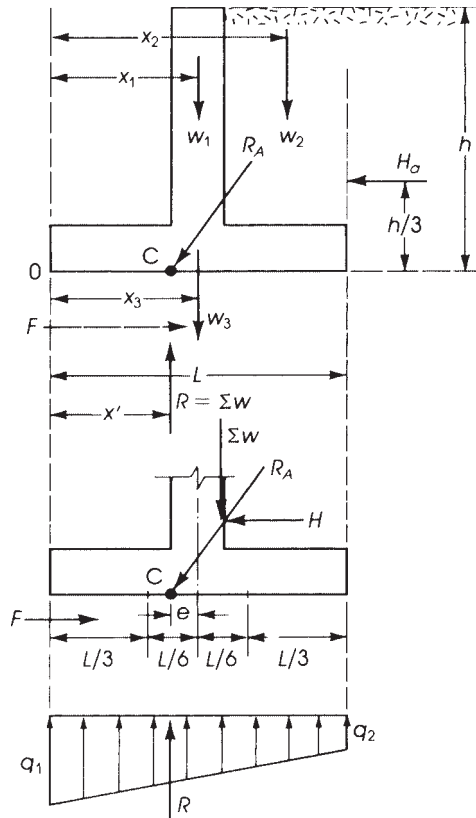


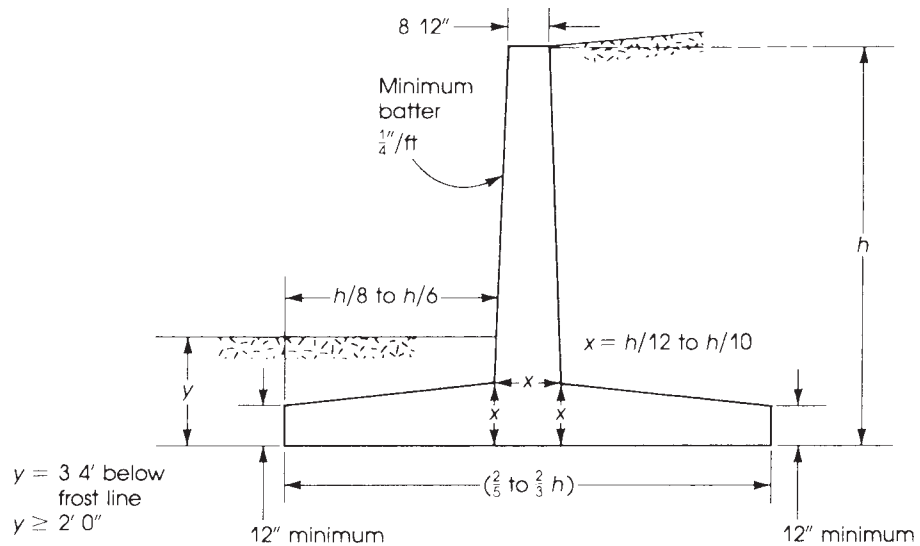
Figure 14.7 Overturning of a cantilever retaining wall.

## 14.8 PROPORTIONS OF RETAINING WALLS

The design of a retaining wall begins with a trial section and approximate dimensions. The assumed section is then checked for stability and structural adequacy. The following rules may be used to determine the approximate sizes of the different parts of a cantilever retaining wall.

1. *Height of Wall.* The overall height of the wall is equal to the difference in elevation required plus 3 to 4 ft, which is the estimated frost penetration depth in northern states.
2. *Thickness of Stem.* The intensity of the pressure increases with the depth of the stem and reaches its maximum value at the base level. Consequently the maximum bending moment and shear in the stem occur at its base. The stem base thickness may be estimated as  $\frac{1}{12}$  to  $\frac{1}{10}$  of the height  $h$ . The thickness at the top of the stem may be assumed to be 8 to 12 in. Because retaining walls are designed for active earth pressure, causing a small deflection of the wall, it is advisable to provide the face of the wall with a batter (taper) of  $\frac{1}{4}$  in. per foot of height,  $h$ , to compensate for the forward deflection. For short walls up to 10 ft high, a constant thickness may be adopted.
3. *Length of Base.* An initial estimate for the length of the base of  $\frac{2}{5}$  to  $\frac{2}{3}$  of the wall height,  $h$ , may be adopted.





**Figure 14.8** Trial proportions of a cantilever retaining wall.

4. *Thickness of Base.* The base thickness below the stem is estimated as the same thickness of the stem at its base, that is,  $\frac{1}{12}$  to  $\frac{1}{10}$  of the wall height. A minimum thickness of about 12 in. is recommended. The wall base may be of uniform thickness or tapered to the ends of the toe and heel, where the bending moment is 0.

The approximate initial proportions of a cantilever retaining wall are shown in Fig. 14.8.

## 14.9 DESIGN REQUIREMENTS

The ACI Code, Chapter 11, provides methods for bearing wall design. The main requirements are as follows:

1. The minimum thickness of bearing walls is  $\frac{1}{25}$  the supported height or length, whichever is shorter, but not less than 4 in.
2. The minimum area of the horizontal reinforcement in the wall is  $0.0025bh$ , where  $bh$  is the gross concrete wall area. This value may be reduced to  $0.0020bh$  if no. 5 or smaller deformed bars with  $f_y \geq 60$  ksi are used. For welded wire fabric (plain or deformed), the minimum steel area is  $0.0020bh$ .
3. The minimum area of the vertical reinforcement is  $0.0015bh$ , but it may be reduced to  $0.0012bh$  if no. 5 or smaller deformed bars with  $f_y \geq 60$  ksi are used. For welded wire fabric (plain or deformed), the minimum steel area is  $0.0012bh$ .
4. The maximum spacing of the vertical or the horizontal reinforcing bars is the smaller of 18 in. or three times the wall thickness.
5. If the wall thickness exceeds 10 in., the vertical and horizontal reinforcement should be placed in two layers parallel to the exterior and interior wall surfaces, as follows:

For exterior wall surfaces, at least  $\frac{1}{2}$  of the reinforcement  $A_s$  (but not more than  $\frac{2}{3}A_s$ ) should have a minimum concrete cover of 2 in. but not more than  $\frac{1}{3}$  of the wall thickness. This is because

the exterior surface of the wall is normally exposed to different weather conditions and temperature changes.

For interior wall surfaces, the balance of the required reinforcement in each direction should have a minimum concrete cover of  $\frac{3}{4}$  in. but not more than  $\frac{1}{3}$  of the wall thickness.

The minimum steel area in the wall footing (heel or toe), according to the ACI Code, Section 7.6.1, is that required for shrinkage and temperature reinforcement, which is  $0.0018bh$  when  $f_y = 60$  ksi and  $0.0020bh$  when  $f_y = 40$  ksi or 50 ksi. Because this minimum steel area is relatively small, it is a common practice to increase it to that minimum  $A_s$  required for flexure:

$$A_{s,\min} = \left( \frac{3\sqrt{f'_c}}{f_y} \right) bd \geq \left( \frac{200}{f_y} \right) bd \quad (14.16)$$

### 14.10 DRAINAGE

The earth pressure discussed in the previous sections does not include any hydrostatic pressure. If water accumulates behind the retaining wall, the water pressure must be included in the design. Surface or underground water may seep into the backfill and develop the case of submerged soil. To avoid hydrostatic pressure, drainage should be provided behind the wall. If well-drained cohesionless soil is used as a backfill, the wall can be designed for earth pressure only. The drainage system may consist of one or a combination of the following:

1. Weep holes in the retaining wall of 4 in. or more in diameter and spaced about 5 ft on centers horizontally and vertically (Fig. 14.9a).
2. Perforated pipe 8 in. in diameter laid along the base of the wall and surrounded by gravel (Fig. 14.9b).
3. Blanketing or paving the surface of the backfill with asphalt to prevent seepage of water from the surface.
4. Any other method to drain surface water.

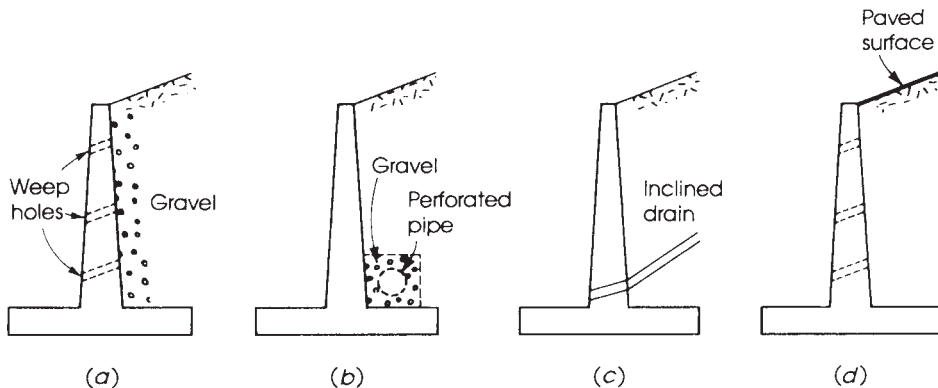


Figure 14.9 Drainage systems.

**Example 14.1**

The trial section of a semigravity plain concrete retaining wall is shown in Fig. 14.10. It is required to check the safety of the wall against overturning, sliding, and bearing pressure under the footing.

Given: Weight of backfill is 110 pcf, angle of internal friction is  $\phi = 35^\circ$ , coefficient of friction between concrete and soil is  $\mu = 0.5$ , allowable soil pressure is 2.5 ksf, and  $f'_c = 3$  ksi.

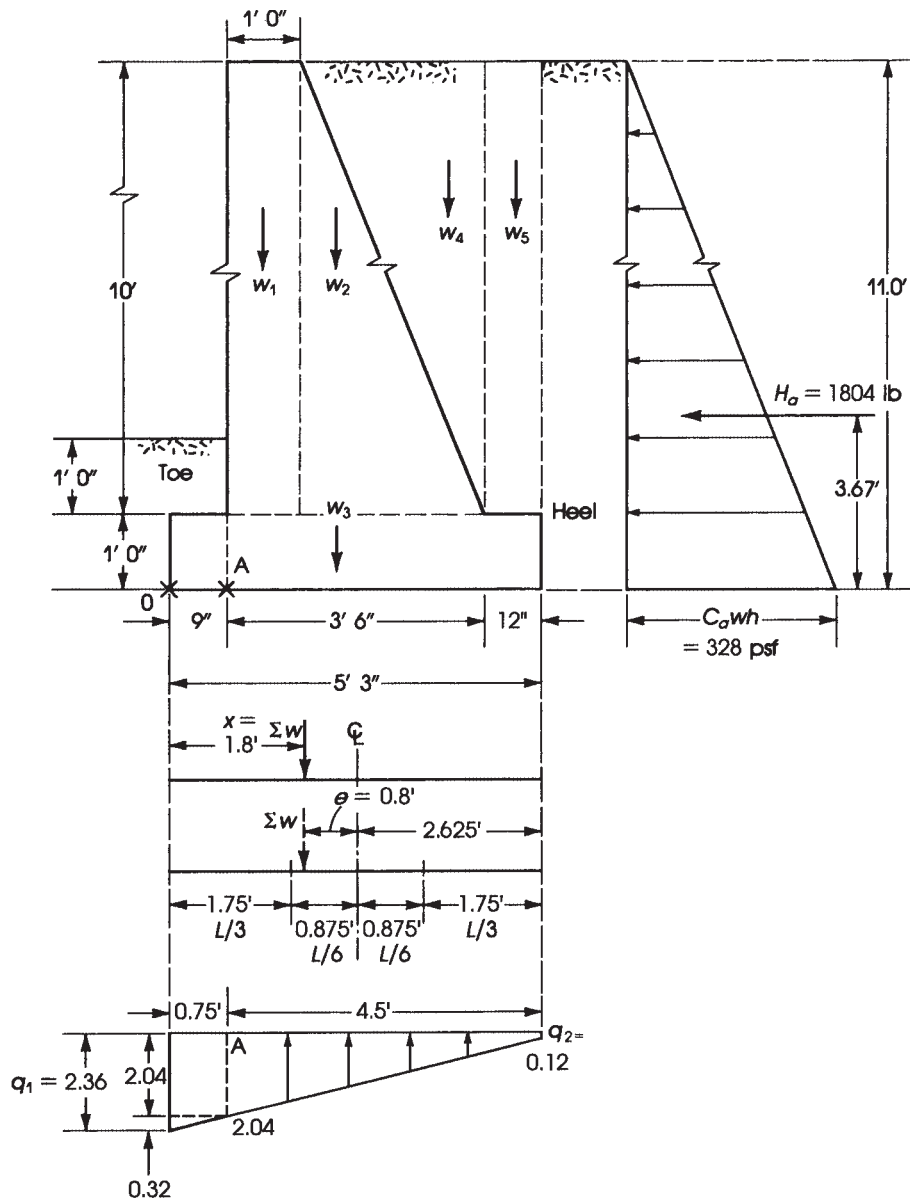


Figure 14.10 Example 14.1.

**Solution**

1. Using the Rankine equation,

$$C_a = \frac{1 - \sin\phi \sin\phi}{1 + \sin\phi} = \frac{1 - 0.574}{1 + 0.574} = 0.271$$

The passive pressure on the toe is that for a height of 1 ft, which is small and can be neglected.

$$H_a = \frac{C_a w h^2}{2} = \frac{0.271}{2} (110)(11)^2 = 1804 \text{ lb}$$

and  $H_a$  acts at a distance  $h/3 = \frac{11}{3} = 3.67$  ft from the bottom of the base.

2. The overturning moment is  $M_0 = 1.804 \times 3.67 = 6.62 \text{ K}\cdot\text{ft}$ .  
 3. Calculate the balancing moment,  $M_b$ , taken about the toe end 0 (Fig. 14.10):

Weight (lb)	Arm (ft)	Moment (K·ft)
$w_1 = 1 \times 10 \times 145 = 1450$	1.25	1.81
$w_2 = \frac{1}{2} \times 2.5 \times 10 \times 145 = 1812$	2.60	4.71
$w_3 = 5.25 \times 1 \times 145 = 725$	2.625	2.00
$w_4 = \frac{1}{2} \times 2.5 \times 10 \times 110 = 1375$	3.42	4.70
$w_5 = \frac{12}{12} \times 10 \times 110 = 1100$	4.75	5.22

$$\sum w = R = 6.50 \text{ K} \quad M_b = \sum M = 18.44 \text{ K}\cdot\text{ft}$$

4. The factor of safety against overturning is  $18.44/6.62 = 2.78 > 2.0$ .  
 5. The force resisting sliding,  $F = \mu R$ , is  $F = 0.5(6.50) = 3.25 \text{ K}$ . The factor of safety against sliding is  $F/H_a = 3.25/1.804 = 1.8 > 1.5$ .  
 6. Calculate the soil pressure under the base:

- a. The distance of the resultant from toe end 0 is

$$x = \frac{M_b - M_0}{R} = \frac{18.44 - 6.62}{6.50} = 1.82 \text{ ft}$$

The eccentricity is  $e = 2.62 - 1.82 = 0.80 \text{ ft}$ . The resultant  $R$  acts just inside the middle third of the base and has an eccentricity of  $e = 0.8 \text{ ft}$  from the center of the base (Fig. 14.10). For a 1-ft length of the footing, the effective width of footing is 5.25 ft.

- b. The moment of inertia is  $I = 1.0(5.25)^3/12 = 12.1 \text{ ft}^4$ . Area = 5.25 ft<sup>2</sup>.  
 c. The soil pressures at the two extreme ends of the footing are  $q_1, q_2 = R/A \pm Mc/I$ . The moment  $M$  is  $Re = 6.50(0.8) = 5.2 \text{ K}\cdot\text{ft}$ ;  $c = 2.62 \text{ ft}$ .

$$q_1 = \frac{6.50}{5.25} + \frac{5.2(2.62)}{12.1} = 1.24 + 1.12 = 2.36 \text{ ksf}$$

$$q_2 = 1.24 - 1.12 = 0.12 \text{ ksf}$$

7. Check the bending stress in concrete at point A of the toe.

- a. Soil pressure at A (from geometry) is

$$q_A = 0.12 + \left( \frac{4.5}{5.25} \right) (2.36 - 0.12) = 2.04 \text{ ksf}$$

- b. Let  $M_A$  be is calculated at A due to a rectangular stress and a triangular stress.

$$\begin{aligned} M_A &= \frac{2.04(0.75)^2}{2} + (0.32 \times 0.75 \times 0.5) \left( 0.75 \times \frac{2}{3} \right) \\ &= 0.63 \text{ K}\cdot\text{ft} \end{aligned}$$

- c. The flexural stress in concrete is

$$\frac{Mc}{I} = \frac{0.63(12,000)(6)}{1728} = 26 \text{ psi}$$

where  $c = h/2 = \frac{12}{2} = 6 \text{ in.}$  and  $I = 12(12)^3/12 = 1728 \text{ in.}^4$

- d. The modulus of rupture of concrete is  $7.5\lambda\sqrt{f'_c} = 410 \text{ psi} > 26 \text{ psi}$ . The factor of safety against cracking is  $410/26 = 16$ . Therefore, the section is adequate. No other sections need to be checked.

### Example 14.2

Design a cantilever retaining wall to support a bank of earth 16.5 ft high. The top of the earth is to be level with a surcharge of 330 psf. Given: The weight of the backfill is 110 pcf, the angle of internal friction is  $\phi = 35^\circ$ , the coefficient of friction between concrete and soil is  $\mu = 0.5$ , the coefficient of friction between soil layers is  $\mu = 0.7$ , allowable soil bearing capacity is 4 ksf,  $f'_c = 3 \text{ ksi}$ , and  $f_y = 60 \text{ ksi}$ .

### Solution

- Determine the dimensions of the retaining wall using the approximate relationships shown in Fig. 14.8.
  - Height of wall: Allowing 3 ft for frost penetration to the bottom of the footing in front of the wall, the height of the wall becomes  $h = 16.5 + 3 = 19.5 \text{ ft}$ .
  - Base thickness: Assume base thickness is  $0.08h = 0.08 \times 19.5 = 1.56 \text{ ft}$ , or 1.5 ft. The height of the stem is  $19.5 - 1.5 = 18 \text{ ft}$ .
  - Base length: The base length varies between  $0.4h$  and  $0.67h$ . Assuming an average value of  $0.53h$ , the base length equals  $0.53 \times 19.5 = 10.3 \text{ ft}$ , say, 10.5 ft. The projection of the base in front of the stem varies between  $0.17h$  and  $0.125h$ . Assume a projection of  $0.17h = 0.17 \times 19.5 = 3.3 \text{ ft}$ , say, 3.5 ft.
  - Stem thickness: The maximum stem thickness is at the bottom of the wall and varies between  $0.08h$  and  $0.1h$ . Choose a maximum stem thickness equal to that of the base, or 1.5 ft. Select a practical minimum thickness of the stem at the top of the wall of 1.0 ft. The minimum batter of the face of the wall is  $\frac{1}{4} \text{ in./ft}$ . For an 18-ft-high wall, the minimum batter is  $\frac{1}{4} \times 18 = 4.5 \text{ in.}$ , which is less than the  $1.5 - 1.0 = 0.5 \text{ ft}$  (6 in.) provided. The trial dimensions of the wall are shown in Fig. 14.11.
- Using the Rankine equation:

$$C_a = \frac{1 - \sin \phi}{1 + \sin \phi} = \frac{1 - 0.574}{1 + 0.574} = 0.271$$

- The factor of safety against overturning can be determined as follows:

- Calculate the actual unfactored forces acting on the retaining wall. First, find those acting to overturn the wall:

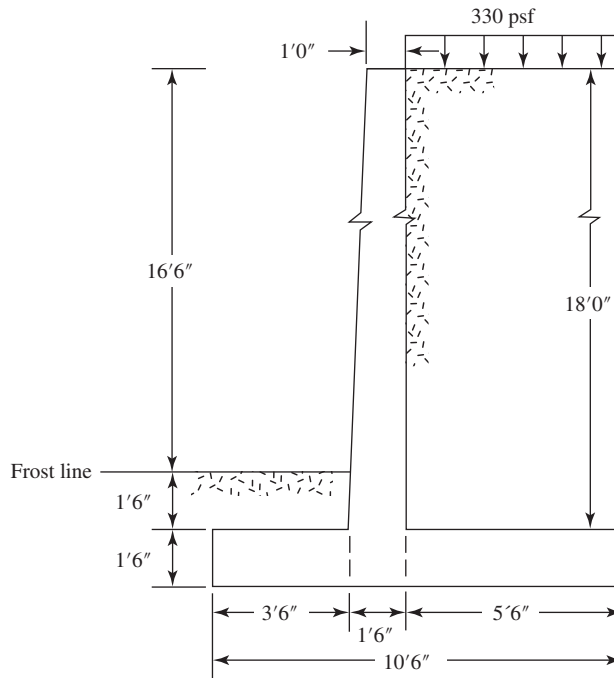
$$h_s(\text{due to surcharge}) = \frac{w_s}{w} = \frac{330}{110} = 3 \text{ ft}$$

$$p_1 = C_a w h_s = 0.271 \times (110 \times 3) = 90 \text{ psf}$$

$$p_2 = C_a w h = 0.271 \times (110 \times 19.5) = 581 \text{ psf}$$

$$H_{a_1} = 90 \times 19.5 = 1755 \text{ lb} \quad \text{Arm} = \frac{19.5}{2} = 9.75 \text{ ft}$$

$$H_{a_2} = 12 \times 581 \times 19.5 = 5665 \text{ lb} \quad \text{Arm} = \frac{19.5}{3} = 6.5 \text{ ft}$$



**Figure 14.11** Example 14.2: Trial configuration of retaining wall.

- b. The overturning moment is  $1.755 \times 9.75 + 5.665 \times 6.5 = 53.93$  K·ft.  
 c. Calculate the balancing moment against overturning (see Fig. 14.12):

Force (lb)	Arm (ft)	Moment (K·ft)
$w_1 = 1 \times 18 \times 150 = 2,700$	4.50	12.15
$w_2 = \frac{1}{2} \times 18 \times \frac{1}{2} \times 150 = 675$	3.83	2.59
$w_3 = 10.5 \times 1.5 \times 150 = 2,363$	5.25	12.41
$w_4 = 5.5 \times 21 \times 110 = 12,705$	7.75	98.46

$$\sum w = R = 18.44 \text{ K} \quad \sum M = 125.61 \text{ K} \cdot \text{ft}$$

$$\text{Factor of safety against overturning} = \frac{125.61}{53.93} = 2.33 > 2.0$$

4. Calculate the base soil pressure. Take moments about the toe end 0 (Fig. 14.12) to determine the location of the resultant  $R$  of the vertical forces.

$$\begin{aligned} x &= \frac{\sum M - \sum Hy}{R} = \frac{\text{balancing } M - \text{overturning } M}{R} \\ &= \frac{125.61 - 53.93}{18.44} = 3.89 \text{ ft} > \frac{10.5}{3} \quad \text{or} \quad 3.5 \text{ ft} \end{aligned}$$

The eccentricity is  $e = 10.5/2 - 3.89 = 1.36$  ft. The resultant  $R$  acts within the middle third of the base and has an eccentricity of  $e = 1.36$  ft from the center of the base. For a 1-ft length of the







The total resisting force is

$$F + H_p = 11.50 + 2.49 = 13.99 \text{ K}$$

The factor of safety against sliding is

$$\frac{13.99}{7.43} = 1.9 \quad \text{or} \quad \frac{11.5}{7.43} = 1.55 > 1.5$$

The factor is greater than 1.5, which is recommended when passive resistance against sliding is not included.

**6.** Design the wall (stem).

- a.** Main reinforcement: The lateral forces applied to the wall are calculated using a load factor of 1.6. The critical section for bending moment is at the bottom of the wall, height = 18 ft. Calculate the applied maximum forces:

$$P_1 = 1.6(C_a w h_s) = 1.6(0.271 \times 110 \times 3) = 143 \text{ lb}$$

$$P_2 = 1.6(C_a w h) = 1.6(0.271 \times 110 \times 18) = 858.3 \text{ lb}$$

$$H_{a1} = 0.143 \times 18 = 2.57 \text{ K} \quad \text{Arm} = \frac{18}{2} = 9 \text{ ft}$$

$$H_{a2} = \frac{1}{2} \times 0.858 \times 18 = 7.72 \text{ K} \quad \text{Arm} = \frac{18}{3} = 6 \text{ ft}$$

$$M_u (\text{at bottom of wall}) = 2.57 \times 9 + 7.72 \times 6 = 69.45 \text{ K} \cdot \text{ft}$$

The total depth used is 18 in.,  $b = 12$  in., and  $d = 18 - 2$  (concrete cover)  $- 0.5$  (half the bar diameter) = 15.5 in.

$$R_u = \frac{M_u}{bd^2} = \frac{69.45 \times 12,000}{12(15.5)^2} = 289 \text{ psi}$$

The steel ratio,  $\rho$ , can be obtained from Table 1 in Appendix A or from

$$\rho = \frac{0.85 f'_c}{f_y} \left[ 1 - \sqrt{\frac{2R_u}{\phi 0.85 f'_c}} \right] = 0.007$$

$$A_s = 0.007(12)(15.5) = 1.3 \text{ in.}^2$$

Use no. 8 bars spaced at 7 in. (1.35 in.<sup>2</sup>). The minimum vertical  $A_s$  according to the ACI Code, Section 11.6, is

$$A_{s,\min} = 0.0015(12)(18) = 0.32 \text{ in.}^2 < 1.35 \text{ in.}^2$$

Because the moment decreases along the height of the wall,  $A_s$  may be reduced according to the moment requirements. It is practical to use one  $A_s$  or spacing, for the lower half and a second  $A_s$ , or spacing, for the upper half of the wall. To calculate the moment at midheight of the wall, 9 ft from the top:

$$P_1 = 1.6(0.271 \times 110 \times 3) = 143 \text{ lb}$$

$$P_2 = 1.6(0.271 \times 110 \times 9) = 429 \text{ lb}$$

$$H_{a1} = 0.143 \times 9 = 1.29 \text{ K} \quad \text{Arm} = \frac{9}{2} = 4.5 \text{ ft}$$

$$H_{a2} = \frac{1}{2} \times 0.429 \times 9 = 1.9 \text{ K} \quad \text{Arm} = \frac{9}{3} = 3 \text{ ft}$$

$$M_u = 1.29 \times 4.5 + 1.9 \times 3 = 11.5 \text{ K} \cdot \text{ft}$$

The total depth at midheight of wall is

$$\frac{12 + 18}{2} = 15 \text{ in.}$$

$$d = 15 - 2 - 0.5 = 12.5 \text{ in.}$$

$$R_u = \frac{M_u}{bd^2} = \frac{11.5 \times 12,000}{12 \times (12.5)^2} = 73.6 \text{ psi}$$

$$\rho = 0.0017 \quad \text{and} \quad A_s = 0.0017(12)(12.5) = 0.25 \text{ in.}^2$$

$$A_{s,\min} = 0.0015 \times 12 \times 15 = 0.27 \text{ in.}^2 > 0.25 \text{ in.}^2$$

Use no. 4 vertical bars spaced at 8 in. (0.29 in.<sup>2</sup>) with similar spacing to the lower vertical steel bars in the wall.

- b.** Temperature and shrinkage reinforcement: The minimum horizontal reinforcement at the base of the wall according to ACI Code, Section 11.6, is

$$A_{s,\min} = 0.0020 \times 12 \times 18 = 0.432 \text{ in.}^2$$

(for the bottom third), assuming no. 5 bars or smaller.

$$A_{s,\min} = 0.0020 \times 12 \times 15 = 0.36 \text{ in.}^2$$

(for the upper two-thirds). Because the front face of the wall is mostly exposed to temperature changes, use one-half to two-thirds of the horizontal bars at the external face of the wall and place the balance at the internal face.

$$0.5A_s = 0.5 \times 0.432 = 0.22 \text{ in.}^2$$

Use no. 4 horizontal bars spaced at 8 in. ( $A_s = 0.29 \text{ in.}^2$ ) at both the internal and external surfaces of the wall. Use no. 4 vertical bars spaced at 12 in. at the front face of the wall to support the horizontal temperature and shrinkage reinforcement.

- c.** Dowels for the wall vertical bars: The anchorage length of no. 8 bars into the footing must be at least 22 in. Use an embedment length of 2 ft into the footing and the key below the stem.
- d.** Design for shear: The critical section for shear is at a distance  $d = 15.5 \text{ in.}$  from the bottom of the stem. At this section, the distance from the top equals  $18 - 15.5/12 = 16.7 \text{ ft.}$

$$P_1 = 1.6(0.271 \times 110 \times 3) = 143 \text{ lb}$$

$$P_2 = 1.6(0.271 \times 110 \times 16.7) = 796 \text{ lb}$$

$$H_{a_1} = 0.143 \times 16.7 = 2.39 \text{ K}$$

$$H_{a_2} = \frac{1}{2} \times 0.796 \times 16.7 = 6.6 \text{ K}$$

$$\text{Total } H = 2.39 + 6.6 = 9.0 \text{ K}$$

$$\begin{aligned} \phi V_c &= \phi(2\lambda\sqrt{f'_c})bd = \frac{0.75 \times 2 \times 1}{1000} \times \sqrt{3000} \times 12 \times 15.5 \\ &= 15.28 \text{ K} > 9.0 \text{ K} \end{aligned}$$

- 7.** Design of the heel: A load factor of 1.2 is used to calculate the factored bending moment and shearing force due to the backfill and concrete, whereas a load factor of 1.6 is used for the surcharge. The upward soil pressure is neglected because it will reduce the effect of the backfill and

concrete on the heel. Referring to Fig. 14.12, the total load on the heel is

$$\begin{aligned} V_u &= \frac{1.2[(18 \times 5.5 \times 110) + (1.5 \times 5.5 \times 150)] + 1.6(3 \times 5.5 \times 100)}{1000} \\ &= 17.5 \text{ K} \end{aligned}$$

$$M_u(\text{at face of wall}) = V_u \times \frac{5.5}{2} = 48.1 \text{ K} \cdot \text{ft}$$

The critical section for shear is usually at a distance  $d$  from the face of the wall when the reaction introduces compression into the end region of the member. In this case, the critical section will be considered at the face of the wall because tension and not compression develops in the concrete.

$$\begin{aligned} V_u &= 17.2 \text{ K} \\ \phi V_c &= \phi(2\lambda\sqrt{f'_c})bd = \frac{0.75 \times 2 \times 1}{1000} \times \sqrt{3000} \times 12 \times 14.5 \\ &= 14.3 \text{ K} \end{aligned}$$

where  $\phi V_c$  is less than  $V_u$  of 17.2 K, and the section must be increased by the ratio 17.5/14.3 or shear reinforcement must be provided.

$$\text{Required } d = \frac{17.2}{14.3} \times 14.5 = 17.4 \text{ in.}$$

$$\text{Total thickness required} = 17.4 + 3.5 = 20.9 \text{ in.}$$

Use a base thickness of 22 in. and  $d = 18.5$  in.

$$R_u = \frac{M_u}{bd^2} = \frac{48.1 \times 12,000}{12 \times (18.5)^2} = 140.5 \text{ psi} \quad \rho = 0.0027$$

$$A_s = \rho bd = 0.60 \text{ in}^2$$

$$\text{Min. shrinkage } A_s = 0.0018(12)(22) = 0.475 \text{ in}^2$$

$$\text{Min. flexural } A_s = 0.0033(12)(18.5) = 0.733 \text{ in}^2$$

Use no. 6 bars spaced at 7 in. ( $A_s = 0.76 \text{ in}^2$ ). The development length for the no. 6 top bars equals  $1.4 l_d = 35$  in. Therefore, the bars must be extended 3 ft into the toe of the base.

Temperature and shrinkage reinforcement in the longitudinal direction is not needed in the heel or toe, but it may be preferable to use minimal amounts of reinforcement in that direction, say, no. 4 bars spaced at 12 in.

8. Design of the toe: The toe of the base acts as a cantilever beam subjected to upward pressures, as calculated in step 4. The factored soil pressure is obtained by multiplying the service load soil pressure by a load factor of 1.6 because it is primarily caused by the lateral forces. The critical section for the bending moment is at the front face of the stem. The critical section for shear is at a distance  $d$  from the front face of the stem because the reaction in the direction of shear introduces compression into the toe.

Referring to Fig. 14.13, the toe is subjected to an upward pressure from the soil and downward pressure due to self-weight of the toe slab:

$$\begin{aligned} V_u &= 1.6 \left( \frac{3.13 + 2.62}{2} \right) \times 1.96 - 1.2 \left( \frac{22}{12} \times 0.150 \right) \times 1.96 \\ &= 837 \text{ K} \end{aligned}$$

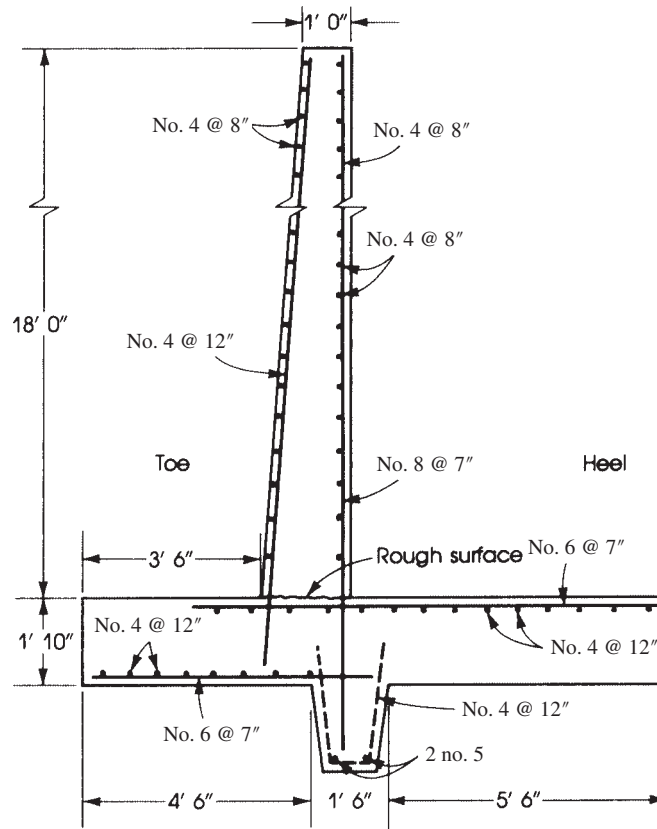


Figure 14.14 Example 14.2: Reinforcement details.

This is less than  $\phi V_c$  of 14.3 K calculated for the heel in step 7.

$$M_u = 1.6 \left[ \frac{2.22}{2} \times (3.5)^2 + (3.13 - 2.22) \times 3.5 \times 0.5 \left( \frac{2}{3} \times 3.5 \right) \right] \\ - 1.2 \left[ \left( \frac{22}{12} \times 0.150 \right) \times \frac{(3.5)^2}{2} \right] = 25.7 \text{ K} \cdot \text{ft}$$

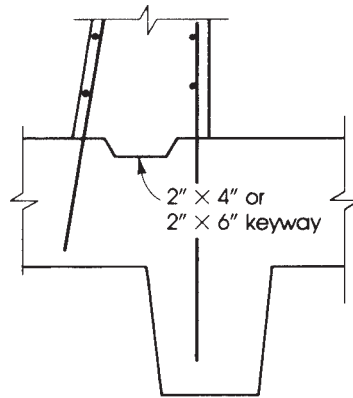
$$R_u = \frac{M_u}{bd^2} = \frac{25.7 \times 12,000}{12 \times (18.5)^2} = 75 \text{ psi} \quad \rho = 0.0017$$

$$A_s = 0.0017(12)(18.5) = 0.377 \text{ in.}^2$$

$$\text{Min. shrinkage } A_s = 0.0018(12)(22) = 0.475 \text{ in.}^2$$

$$\text{Min. flexural } A_s = 0.0033(12)(18.5) = 0.733 \text{ in.}^2$$

Use no. 6 bars spaced at 7 in., similar to the heel reinforcement. Development length of no. 6 bars equals 25 in. Extend the bars into the heel 25 in. The final reinforcement details are shown in Fig. 14.14.



**Figure 14.15** Example 14.2: Keyway details.

9. Shear keyway between wall and footing: In the construction of retaining walls, the footing is cast first and then the wall is cast on top of the footing at a later date. A construction joint is used at the base of the wall. The joint surface takes the form of a keyway, as shown in Fig. 14.15, or is left in a very rough condition (Fig. 14.14). The joint must be capable of transmitting the stem shear into the footing.
10. Proper drainage of the backfill is essential in this design because the earth pressure used is for drained backfill. Weep holes should be provided in the wall, 4 in. in diameter and spaced at 5 ft in the horizontal and vertical directions.

## 14.11 BASEMENT WALLS

It is a common practice to assume that basement walls span vertically between the basement-floor slab and the first-floor slab. Two possible cases of design should be investigated for a basement wall.

First, when the wall only has been built on top of the basement floor slab, the wall will be subjected to lateral earth pressure with no vertical loads except its own weight. The wall in this case acts as a cantilever, and adequate reinforcement should be provided for a cantilever wall design. This case can be avoided by installing the basement and the first-floor slabs before backfilling against the wall.

Second, when the first-floor and the other floor slabs have been constructed and the building is fully loaded, the wall in this case will be designed as a propped cantilever wall subjected to earth pressure and to vertical load.

In addition to drainage, a waterproofing or damp-proofing membrane must be laid or applied to the external face of the wall. The ACI Code, Section 11.3.1.1, specifies that the minimum thickness of an exterior basement wall and its foundation is 7.5 in. In general, the minimum thickness of bearing walls is  $\frac{1}{25}$  of the supported height or length, whichever is shorter, or 4 in.



Basement wall.

**Example 14.3**

Determine the thickness and necessary reinforcement for the basement retaining wall shown in Fig. 14.16. Given: Weight of backfill = 110 pcf, angle of internal friction =  $35^\circ$ ,  $f'_c = 3$  ksi, and  $f_y = 60$  ksi.

**Solution**

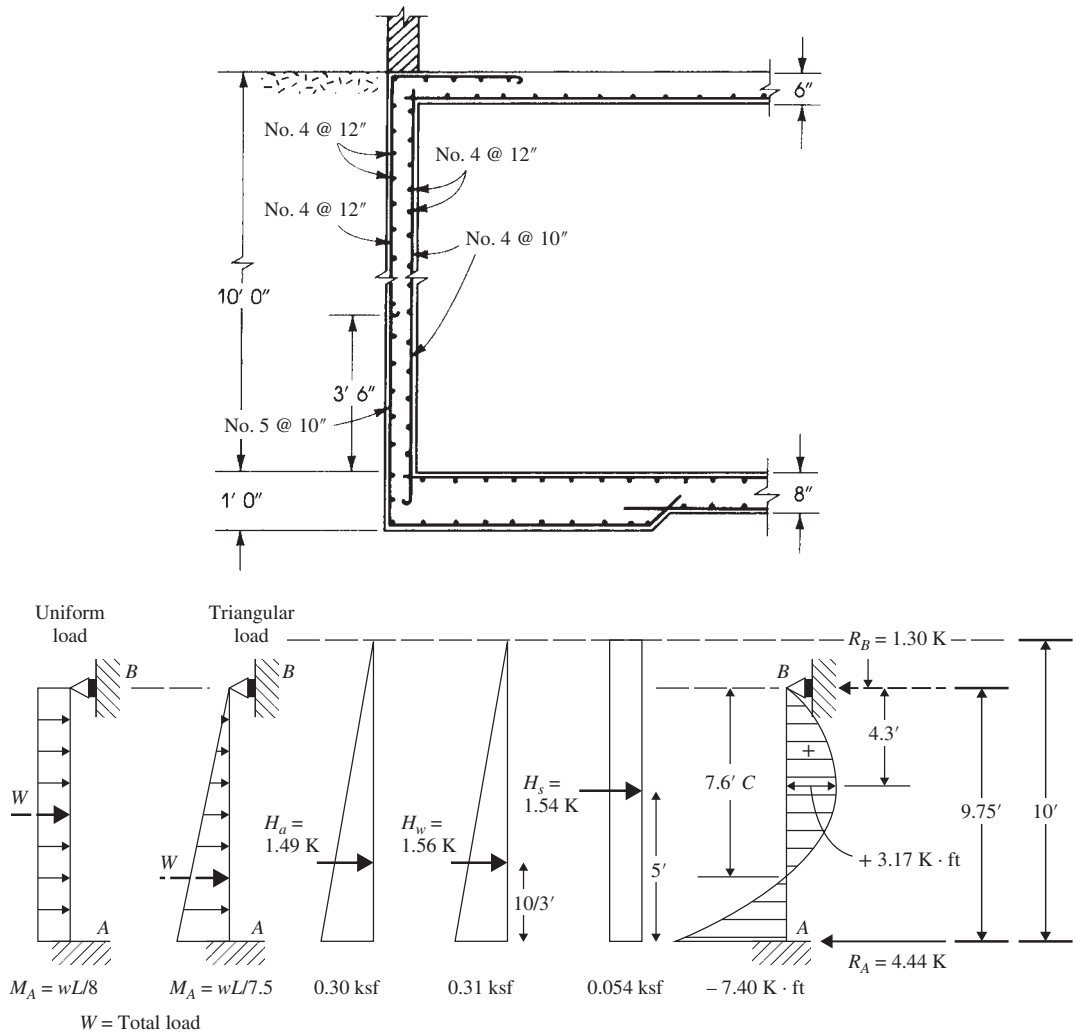
1. The wall spans vertically and will be considered as fixed at the bottom end and propped at the top. Consider a span of  $L = 9.75$  ft, ( $10 - 3/12 = 9.75$  ft) as shown in Fig. 14.16.
2. For these data, the different lateral pressures on a 1-ft length of the wall are as follows:  
For an angle of internal friction of  $35^\circ$ , the coefficient of active pressure is  $C_a = 0.271$ . The horizontal earth pressure at the base is  $P_a = C_a wh$ . For  $w = 110$  pcf and an basement height of  $h = 10$  ft, then

$$P_a = 0.271 \times 0.110 \times 10 = 0.3 \text{ ksf}$$

$$H_a = 0.271 \times 0.110 \times \frac{100}{2} = 1.49 \text{ K/ft of wall}$$

$H_a$  acts at  $h/3 = 10/3 = 3.33$  ft from the base. An additional pressure must be added to allow for a surcharge of about 200 psf on the ground behind the wall. The equivalent height to the surcharge is

$$h_s = \frac{200}{110} = 1.82 \text{ ft}$$



**Figure 14.16** Example 14.3: Basement wall.

$$P_s = C_a w h_s = 0.271 \times 0.110 \times 1.82 = 0.054 \text{ ksf}$$

$$H_s = C_a w h_s \times h = 0.054 \times 10 = 0.54 \text{ K/ft of wall}$$

$H_s$  of the surcharge acts at  $h/2 = 5$  ft from the base

In the preceding calculations, it is assumed that the backfill is dry, but it is necessary to investigate the presence of water pressure behind the wall. The maximum water pressure occurs when the whole height of the basement wall is subjected to water pressure, and

$$P_w = w h = 62.5 \times 10 = 625 \text{ psf}$$

$$H_w = \frac{w h^2}{2} = \frac{0.625 \times 10^2}{2} = 3.125 \text{ K/ft of wall}$$

The maximum pressure may not be present continuously behind the wall. Therefore, if the ground is intermittently wet, a percentage of the preceding pressure may be adopted, say, 50%:

In summary: Due to active soil pressure,  $P_a = 0.30$  ksf,  $H_a = 1.49$  K. Due to water pressure,  $P_w = 0.31$  ksf,  $H_w = 1.56$  K. Due to surcharge,  $P_s = 0.054$  ksf,  $H_s = 0.54$  K.  $H_a$  and  $H_w$  are due to triangular loadings, whereas  $H_s$  is due to uniform loading. 10 ft are used to calculate  $H_a$ ,  $H_w$  and  $H_s$  as the applied pressure over entire wall without the base. Pressure calculation is shown above.

3. Referring to Fig. 14.16 and using moment coefficients of a propped beam subjected to triangular and uniform loads, and a load factor = 1.6, the maximum moment  $M_u$  at A can be calculated from:

$$\begin{aligned} M_u &= 1.6(H_a + H_w) \frac{L}{7.5} + 1.6H_s \frac{L}{8} \\ &= 1.6 \left( \frac{(1.49 + 1.56)}{7.5} \times 9.75 + 0.54 \times \frac{9.75}{8} \right) = 7.40 \text{ K} \cdot \text{ft} \\ R_B(9.75) &= 1.6 \left( \frac{(1.49 + 1.56)(9.75)}{3} + \frac{0.54(9.75)}{2} \right) - 7.40 \\ R_B &= 1.30 \text{ K} \\ R_A &= 1.6(1.49 + 1.56 + 0.54) - 1.30 = 4.44 \text{ K} \end{aligned}$$

Maximum positive bending moment within the span occurs at the section of 0 shear. Assume  $x$  from the top roof of the basement wall:

$$V_u = 1.3 - 1.6(0.054x) - 1.6 \left( (0.30 + 0.31) \frac{x^2}{2} \right) = 0$$

$$x = 4.3 \text{ ft}$$

$$\begin{aligned} M_c &= 1.3 \times 4.3 - 1.6 \left[ \frac{0.054}{2} (10 - 9.75 + 4.3)^2 \right. \\ &\quad \left. + \frac{[(0.31 + 0.30)(10 - 9.75 + 4.3)/10]}{2} \frac{(10 - 9.75 + 4.3)^2}{3} \right] \\ &= +3.17 \text{ K} \cdot \text{ft} \end{aligned}$$

4. Assuming 0.01 steel ratio and one feet strip,  $R_u = 332$  psi,

$$d = \sqrt{\frac{M_u}{R_u b}} = \sqrt{\frac{7.40 \times 12}{0.332 \times 12}} = 4.72 \text{ in.}$$

Total depth = 4.72 + 1.5 (concrete cover) + 0.25 = 6.47 in. Use a  $7\frac{1}{2}$  in. slab;  $d = 5.75$  in.

$$R_u = \frac{M_u}{bd^2} = \frac{7.40 \times 12,000}{12 \times (5.75)^2} = 224 \text{ psi}$$

The steel ratio is  $\rho = 0.005$  and  $A_s = 0.005 \times 12 \times 5.75 = 0.345 \text{ in.}^2$

$$\text{Minimum } A_s = 0.0015bh = 0.0015(12)(7.5) = 0.135 \text{ in.}^2 \quad (\text{vertical bars})$$

$$\text{Minimum } A_s (\text{flexure}) = 0.0033(12)(5.75) = 0.23 \text{ in.}^2$$

Use no. 5 bars spaced at 10 in. ( $A_s = 0.37 \text{ in.}^2$ ).

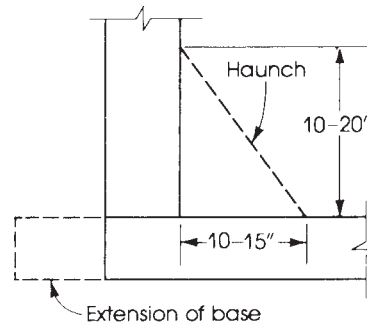
5. For the positive moment,  $M_c = +3.17 \text{ K} \cdot \text{ft}$ :

$$R_u = \frac{3.17 \times 12,000}{12 \times (5.75)^2} = 96 \text{ psi} \quad \rho = 0.0018$$

$$A_s = 0.0018 \times 12 \times 5.75 = 0.125 \text{ in.}^2 < 0.23 \text{ in.}^2$$

Use no. 4 bars spaced at 10 in. ( $A_s = 0.24 \text{ in.}^2$ ).





**Figure 14.17** Example 14.3: Adjustment of wall base.

6. Zero moment occurs at a distance of 7.6 ft from the top and 2.15 ft from the base. The development length of no. 5 bars is 14 in. Therefore, extend the main no. 5 bars to a distance of  $2.15 + 1.2 = 3.35$  ft, or 3.5 ft, above the base; then use no. 4 bars spaced at 12 in. at the exterior face. For the interior face, use no. 4 bars spaced at 10 in. throughout.
7. Longitudinal reinforcement: Use a minimum steel ratio of 0.0020 (ACI Code, Section 11.6), or  $A_s = 0.0020 \times 7 \times 12 = 0.17 \text{ in}^2$ . Use no. 4 bars spaced at 12 in. on each side of the wall.
8. If the bending moment at the base of the wall is quite high, it may require a thick wall slab, for example, 12 in. or more. In this case a haunch may be adopted, as shown in Fig. 14.17. This solution will reduce the thickness of the wall because it will be designed for the moment at the section exactly above the haunch.
9. The basement slab may have a thickness greater than the wall thickness and may be extended outside the wall by about 10 in. or more, as required.

## SUMMARY

### Sections 14.1–14.3

1. A retaining wall maintains unequal levels of earth on its two faces. The most common types of retaining walls are gravity, semigravity, cantilever, counterfort, buttressed, and basement walls.
2. For a linear pressure, the active and passive pressure intensities are

$$P_a = C_a wh \quad \text{and} \quad P_p = C_p wh$$

According to Rankine's theory,

$$C_a = \frac{1 - \sin \phi}{1 + \sin \phi} \quad \text{and} \quad C_p = \frac{1 + \sin \phi \sin \phi}{1 - \sin \phi \sin \phi}$$

Values of  $C_a$  and  $C_p$  for different values of  $\phi$  and  $\delta$  are given in Tables 14.2 and 14.3.

### Sections 14.4 and 14.5

1. When soil is saturated, the submerged unit weight must be used to calculate earth pressure. The hydrostatic water pressure must also be considered.
2. A uniform surcharge on a retaining wall causes an additional pressure height,  $h_s = w_s/w$ .

**Sections 14.6–14.8**

1. A total frictional force,  $F$ , to resist sliding effect is

$$F = \mu R + H_p \quad (\text{Eq. 14.13})$$

$$\text{Factor of safety against sliding} = \frac{F}{H_{ah}} \geq 1.5 \quad (\text{Eq. 14.14})$$

2. Factor of safety against overturning is

$$\frac{M_b}{M_0} = \frac{\sum wx}{H_a h/3} \geq 2.0$$

3. Approximate dimensions of a cantilever retaining wall are shown in Fig. 14.8.

**Sections 14.9 and 14.10**

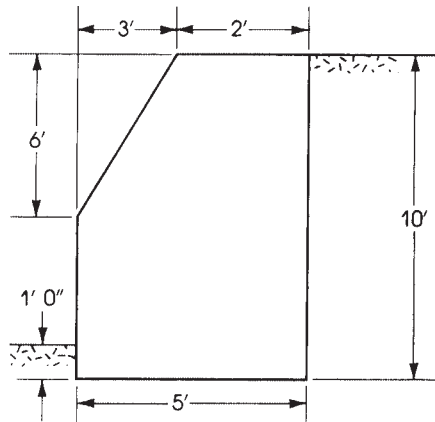
1. Minimum reinforcement is needed in retaining walls.
2. To avoid hydrostatic pressure on a retaining wall, a drainage system should be used that consists of weep holes, perforated pipe, or any other adequate device.
3. Basement walls in buildings may be designed as propped cantilever walls subjected to earth pressure and vertical loads. This case occurs only if the first-floor slab has been constructed. A surcharge of 200 psf may be adopted.

**REFERENCES**

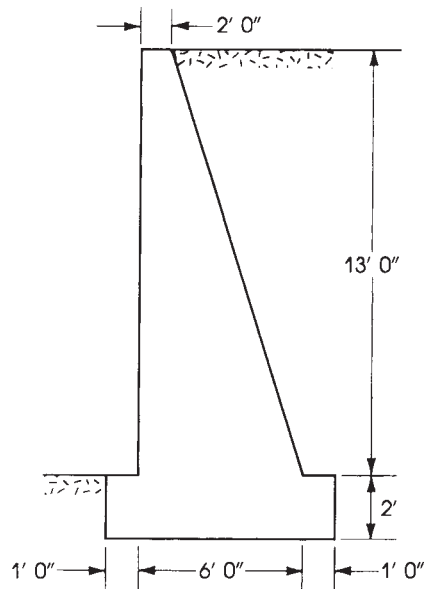
1. K. Terzaghi and R. B. Peck. *Soil Mechanics in Engineering Practice*. Wiley, New York, 1968.
2. W. C. Huntington. *Earth Pressures and Retaining Walls*. Wiley, New York, 1957.
3. G. P. Fisher and R. M. Mains. "Sliding Stability of Retaining Walls." *Civil Engineering* (July 1952): 490.
4. "Retaining Walls and Abutments." In *AREA Manual*, vol. 1. American Railway and Engineering Association, Chicago, 1958.
5. M. S. Ketchum. *The Design of Walls, Bins and Grain Elevators*, 3rd ed. McGraw-Hill, New York, 1949.
6. J. E. Bowles. *Foundation Analysis and Design*. McGraw-Hill, New York, 1980.
7. American Concrete Institute (ACI). *Building Code Requirements for Structural Concrete*. ACI Code 318-14. ACI, Detroit, MI, 2014.

**PROBLEMS**

- 14.1 Check the adequacy of the retaining wall shown in Fig. 14.18 with regard to overturning, sliding, and the allowable soil pressure. Given: Weight of backfill = 110 pcf, the angle of internal friction is  $\phi = 30^\circ$ , the coefficient of friction between concrete and soil is  $\mu = 0.5$ , allowable soil pressure = 3.5 ksf, and  $f'_c = 3$  ksi.
- 14.2 Repeat Problem 14.1 with Fig. 14.19.



**Figure 14.18** Problem 14.1: Gravity wall.



**Figure 14.19** Problem 14.2: Semigravity wall.

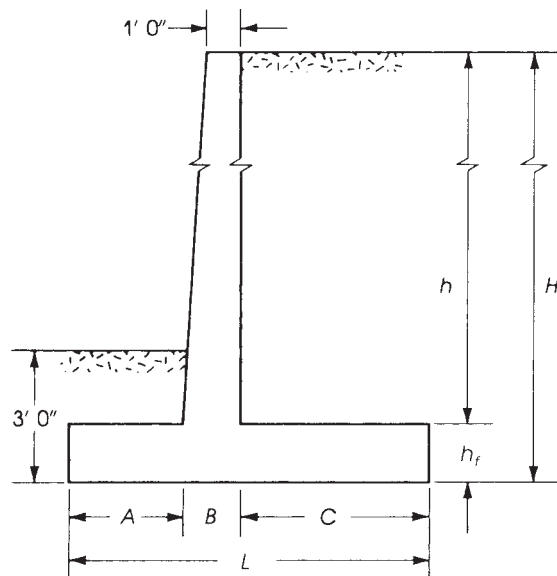
**14.3** For each problem in Table 14.4, determine the factor of safety against overturning and sliding. Also, determine the soil pressure under the wall footing and check if all calculated values are adequate (equal or below the allowable values). Given: Weight of soil = 110 pcf, weight of concrete = 150 pcf, and the coefficient of friction between concrete and soil is 0.5 and between soil layers is 0.6. Consider that the allowable soil pressure of 4 ksf and the top of the backfill is level without surcharge. Ignore the passive soil resistance. See Fig. 14.20 ( $\phi = 35^\circ$ ).

**14.4** Repeat Problems 14.3e–h, assuming a surcharge of 300 psf.

**Table 14.4** Problem

Problem No.	$H$	$h_f$	$A$	$B$	$C$	$L$
a	12	1.00	2.0	1.0	4.0	7
b	14	1.50	2.0	1.5	4.5	8
c	15	1.50	2.0	1.5	4.5	8
d	16	1.50	3.0	1.5	4.5	9
e	17	1.50	3.0	1.5	4.5	9
f	18	1.75	3.0	1.75	5.25	10
g	19	1.75	3.0	1.75	5.25	10
h	20	2.00	3.0	2.0	6.0	11
i	21	2.00	3.5	2.0	6.5	12
j	22	2.00	3.5	2.0	6.5	12

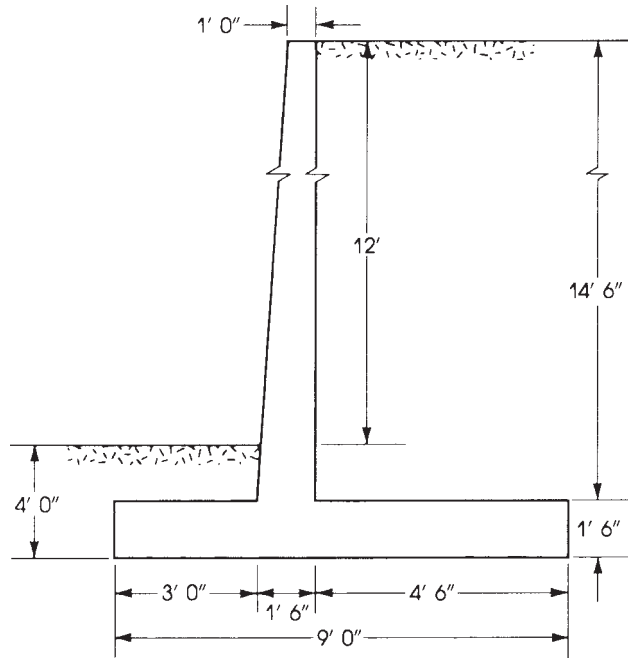
Refer to Fig. 14.20. All dimensions are in feet.

**Figure 14.20** Problem 14.3.

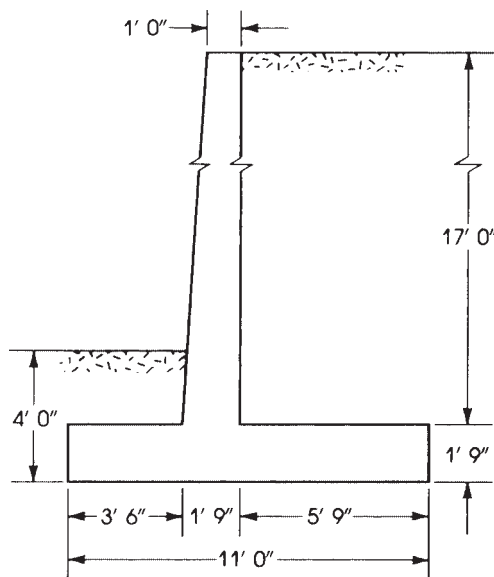
- 14.5** Repeat Problems 14.3e–h, assuming that the backfill slopes at  $10^\circ$  to the horizontal. (Add key if needed.)
- 14.6** For Problems 14.3e–h, determine the reinforcement required for the stem, heel, and toe, and choose adequate bars and distribution. Use  $f'_c = 3$  ksi and  $f_y = 60$  ksi.
- 14.7** Determine the dimensions of a cantilever retaining wall to support a bank of earth 16 ft high. Assume that frost penetration depth is 4 ft. Check the safety of the retaining wall against overturning and sliding only. Given: Weight of backfill = 120 pcf, angle of internal friction =  $33^\circ$ , coefficient of friction between concrete and soil = 0.45, coefficient of friction between soil layers = 0.65, and allowable soil pressure = 4 ksf. Use a  $1.5 \times 1.5$ -ft key if needed.
- 14.8** A complete design is required for the retaining wall shown in Fig. 14.21. The top of the backfill is to be level without surcharge. Given: Weight of backfill soil = 110 pcf, angle of internal friction =  $35^\circ$ ,

the coefficient of friction between concrete and soil is 0.55 and that between soil layers is 0.6. Use  $f'_c = 3$  ksi, and  $f_y = 60$  ksi, and an allowable soil pressure of 4 ksf.

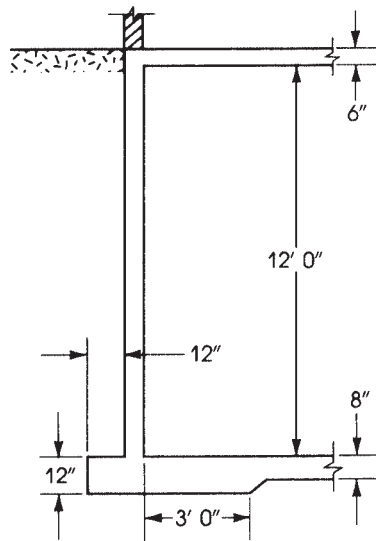
- 14.9** Check the adequacy of the cantilever retaining wall shown in Fig. 14.22 for both sliding and overturning conditions. Use a key of  $1.5 \times 1.5$  ft if needed. Then determine reinforcement needed for the stem, heel, and toe, and choose adequate bars and distribution. Given: Weight of soil = 120 pcf, the angle of internal



**Figure 14.21** Problem 14.8: Cantilever retaining wall.



**Figure 14.22** Problem 14.9: Cantilever retaining wall.



**Figure 14.23** Problem 14.11: Basement wall.

friction is  $\phi = 35^\circ$ , the coefficient of friction between concrete and soil is 0.52 and that between soil layers is 0.70. Use  $f'_c = 3$  ksi,  $f_y = 60$  ksi, an allowable soil pressure of 4 ksf, and a surcharge of 300 psf.

- 14.10** Repeat Problem 14.9, assuming the backfill slopes at  $30^\circ$  to the horizontal.
- 14.11** Determine the thickness and necessary reinforcement for the basement wall shown in Fig. 14.23. The weight of backfill is 120 pcf and the angle of internal friction is  $\phi = 30^\circ$ . Assume a surcharge of 400 psf and use  $f'_c = 3$  ksi and  $f_y = 60$  ksi.
- 14.12** Repeat Problem 14.11 using a basement clear height of 14 ft.

# CHAPTER 15

## DESIGN FOR TORSION



Apartment building, Habitat 67, Montreal, Canada.

### 15.1 INTRODUCTION

Torsional stresses develop in a beam section when a moment acts on that section parallel to its surface. Such moments, called torsional moments, cause a rotation in the structural member and cracking on its surface, usually in the shape of a spiral. To illustrate torsional stresses, let a torque,  $T$ , be applied on a circular cantilever beam made of elastic homogeneous material, as shown in Fig. 15.1. The torque will cause a rotation of the beam. Point  $B$  moves to point  $B'$  at one end of the beam, whereas the other end is fixed. The angle  $\theta$  is called the angle of twist. The plane  $AO'OB$  will be distorted to the shape  $AO'OB'$ . Assuming that all longitudinal elements have the same length, the shear strain is

$$\gamma = \frac{BB'}{L} = \frac{r\theta}{L}$$

where  $L$  is the length of the beam and  $r$  is the radius of the circular section.

In reinforced concrete structures, members may be subjected to torsional moments when they are curved in plan, support cantilever slabs, act as spandrel beams (end beams), or are part of a spiral stairway.

Structural members may be subjected to pure torsion only or, as in most cases, subjected simultaneously to shearing forces and bending moments. Example 15.1 illustrates the different forces that may act at different sections of a cantilever beam.

---

#### Example 15.1

Calculate the forces acting at sections 1, 2, and 3 of the cantilever beam shown in Fig. 15.2. The beam is subjected to a vertical force  $P_1 = 15$  K, a horizontal force  $P_2 = 12$  K acting at  $C$ , and a horizontal force  $P_3 = 20$  K acting at  $B$  and perpendicular to the direction of the force  $P_2$ .

#### Solution

Let  $N$  be the normal force,  $V$  the shearing force,  $M$  the bending moment, and  $T$  the torsional moment. The forces are as follows:

---

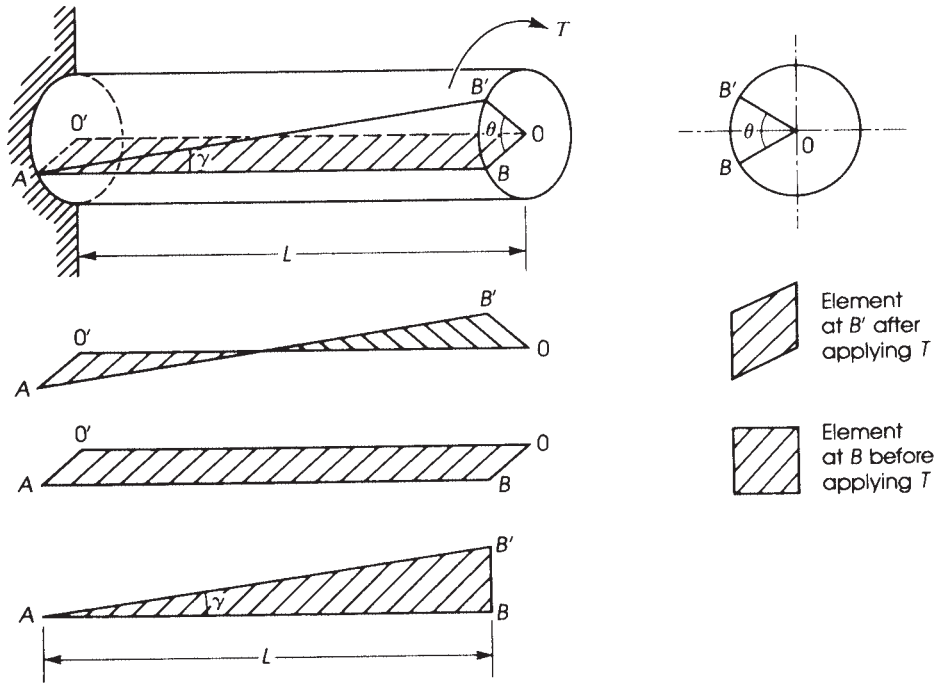


Figure 15.1 Torque applied to a cantilever beam.

Section	$N$ (K)	$M_x$ (K · ft)	$M_y$ (K · ft)	$V_x$ (K)	$V_y$ (K)	$T$ (K · ft)
1	0	-135 (15 × 9)	+108 (12 × 9)	+12	+15	0
2	-12 Compression	0	+108	+20	+15	135 (15 × 9)
3	-12 Compression	-180	+348	+20	+15	135 (15 × 9)

If  $P_1, P_2,$  and  $P_3$  are factored loads ( $P_u = 1.2 P_D + 1.6 P_L$ ), then the values in the table will be the factored design forces.

### 15.2 TORSIONAL MOMENTS IN BEAMS

It was shown in Example 15.1 that forces can act on building frames, causing torsional moments. If a concentrated load  $P$  is acting at point  $C$  in the frame  $ABC$  shown in Fig. 15.3a, it develops a torsional moment in beam  $AB$  of  $T = PZ$  acting at  $D$ . When  $D$  is at midspan of  $AB$ , then the torsional design moment in  $AD$  equals that in  $DB$ , or  $\frac{1}{2}T$ . If a cantilever slab is supported by the beam  $AB$  in Fig. 15.3b, the slab causes a uniform torsional moment  $m_t$  along  $AB$ . This uniform torsional moment is due to the load on a unit width strip of the slab. If  $S$  is the width of the cantilever slab and  $w$  is



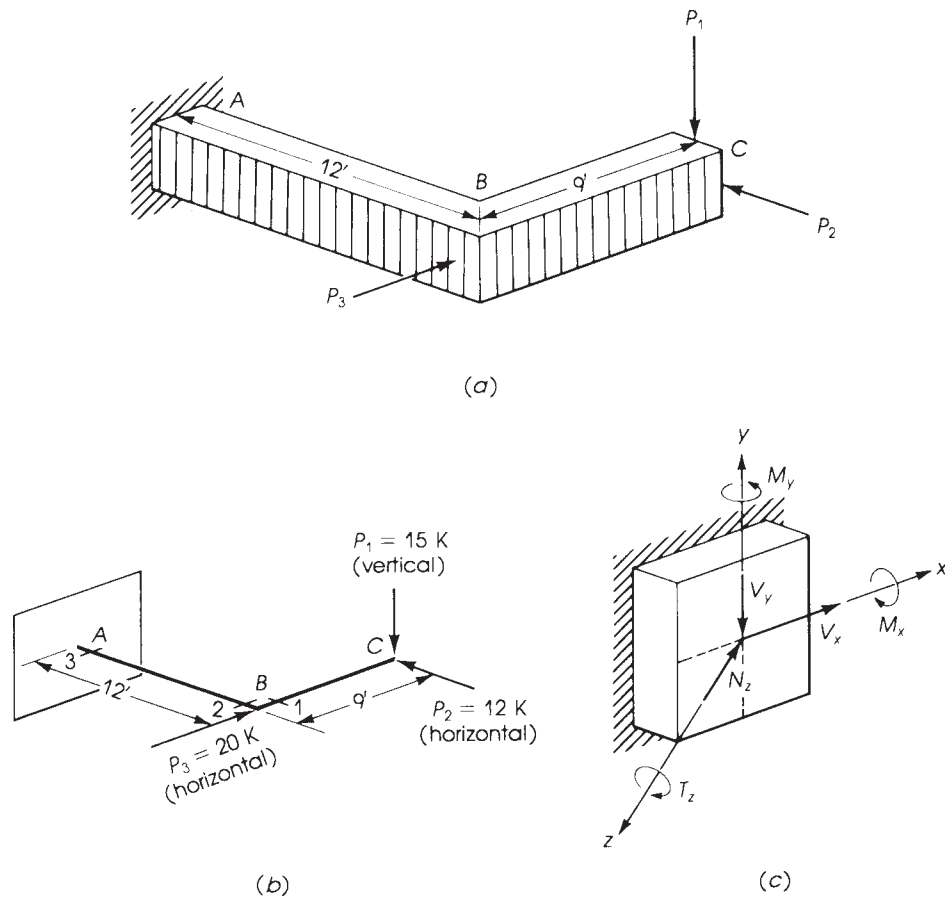


Figure 15.2 Example 15.1.

load on the slab (psf), then  $m_t = wS^2/2$  K ft/ft of beam  $AB$ . The maximum torsion design moment in beam  $AB$  is  $T = \frac{1}{2}m_tL$  acting at  $A$  and  $B$ . Other cases of loading are explained in Table 15.1. In general, the distribution of torsional moments in beams has the same shape and numerically has the same values as the shear diagrams for beams subjected to a load  $m_t$  or  $T$ .

### 15.3 TORSIONAL STRESSES

Considering the cantilever beam with circular section of Fig. 15.1, the torsional moment  $T$  will cause a shearing force  $dV$  perpendicular to the radius of the section. From the conditions of equilibrium, the external torsional moment is resisted by an internal torque equal to and opposite to  $T$ . If  $dV$  is the shearing force acting on the area  $dA$  (Fig. 15.4), then the magnitude of the torque is  $T = \int r dV$ . Let the shearing stress be  $v$ ; then

$$dV = v dA \quad \text{and} \quad T = \int rv dA$$

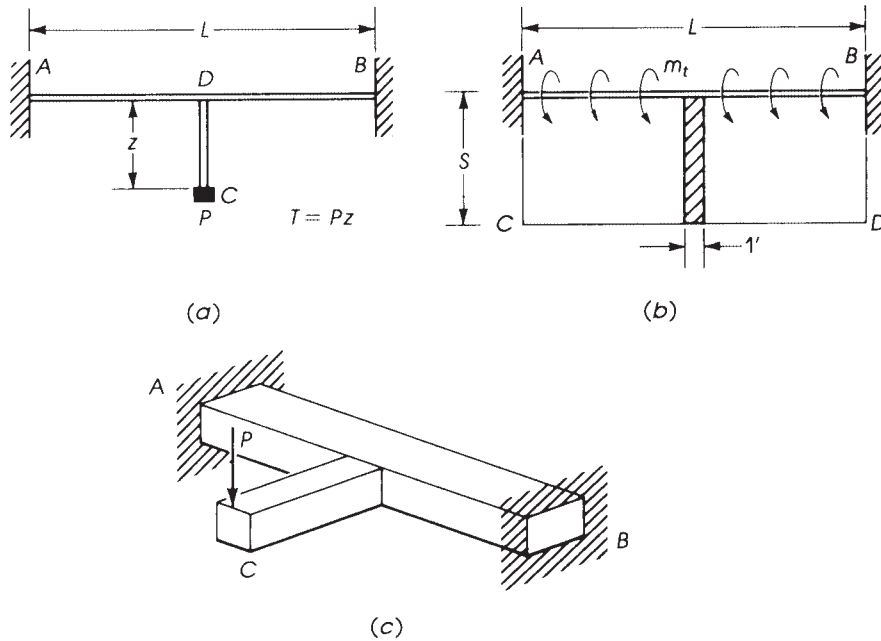


Figure 15.3 Torsional moments on AB.

The maximum elastic shear occurs at the external surface of the circular section at radius  $r$  with thickness  $dr$ ; then the torque  $T$  can be evaluated by taking moments about the center  $O$  for the ring area:

$$dT = (2\pi r dr)v r$$

where  $(2\pi r dr)$  is the area of the ring and  $v$  is the shear stress in the ring. Thus,

$$T = \int_0^R (2\pi r dr)v r = \int_0^R 2\pi r^2 v dr \quad (15.1)$$

For a hollow section with internal radius  $R_1$ ,

$$T = \int_{R_1}^R 2\pi r^2 v dr \quad (15.2)$$

For a solid section, using Eq. 15.1 and using  $v = v_{\max} r/R$ ,

$$\begin{aligned} T &= \int_0^R 2\pi r^2 \left( \frac{v_{\max} r}{R} \right) dr = \left( \frac{2\pi}{R} \right) v_{\max} \int_0^R r^3 dr \\ &= \left( \frac{2\pi}{R} \right) v_{\max} \times \frac{R^4}{4} = \left( \frac{\pi}{2} \right) v_{\max} R^3 \\ v_{\max} &= \frac{2T}{\pi R^3} \end{aligned} \quad (15.3)$$

**Table 15.1** Torsion Diagrams

	<p>At support <math>M_t = T</math></p>	<p>For a circular section <math>J = \frac{\pi R^4}{2}</math></p>
	<p>At support <math>M_t = m_t L</math> <math>m_t = \text{uniform torque}</math></p>	
	<p><math>M_{t1} = M_{t2} = \frac{T}{2}</math></p>	
	<p><math>M_{t1} = \frac{Tb}{L}</math> <math>M_{t2} = \frac{Ta}{L}</math></p>	
	<p><math>M_{t1} = \frac{T_1(b-c) + T_2c}{L}</math>  <math>M_{t2} = \frac{T_2c - T_1a}{L}</math>  <math>M_{t3} = \frac{T_1a - T_2(a+b)}{L}</math>                      Note: When <math>a = b = c = L/3</math> and <math>T_1 = T_2 = T</math>, <math>M_{t1} = M_{t3} = T \cdot M_{t2} = 0</math></p>	

(continued)

Table 15.1 (Continued)

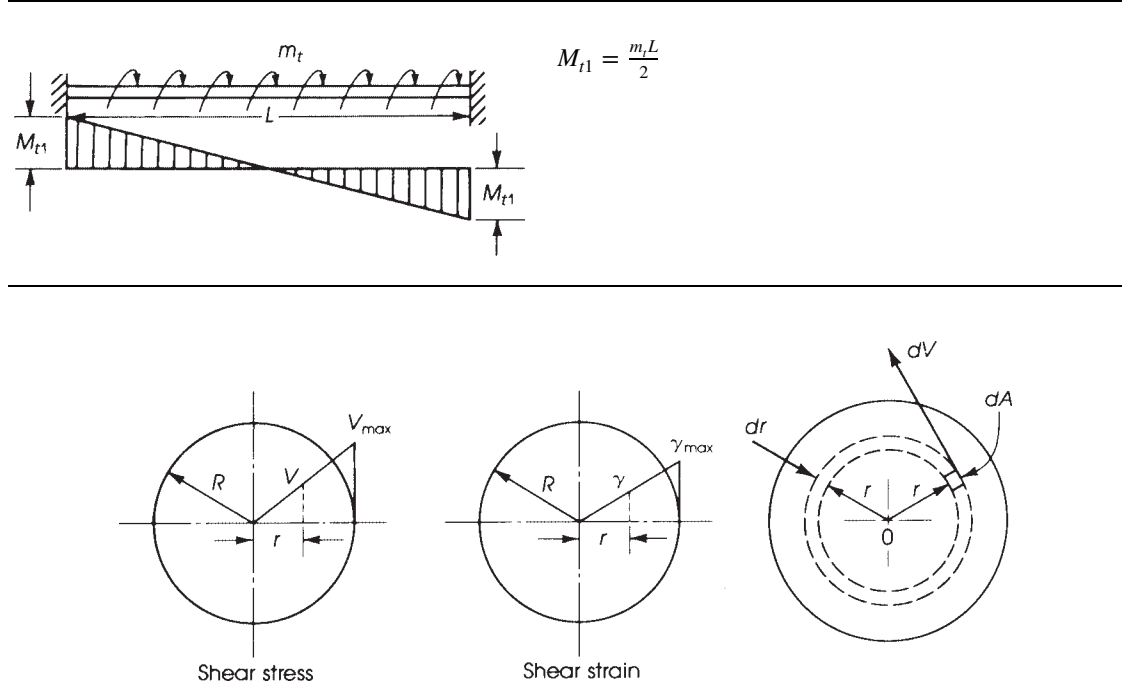


Figure 15.4 Torque in circular sections.

The polar moment of inertia of a circular section is  $J = \pi R^4/2$ . Therefore, the shear stress can be written as a function of the polar moment of inertia  $J$  as follows:

$$v_{\max} = \frac{TR}{J} \quad (15.4)$$

## 15.4 TORSIONAL MOMENT IN RECTANGULAR SECTIONS

The determination of the stress in noncircular members subjected to torsional loading is not as simple as that for circular sections. However, results obtained from the theory of elasticity indicate that the maximum shearing stress for rectangular sections can be calculated as follows:

$$v_{\max} = \frac{T}{\alpha x^2 y} \quad (15.5)$$

where

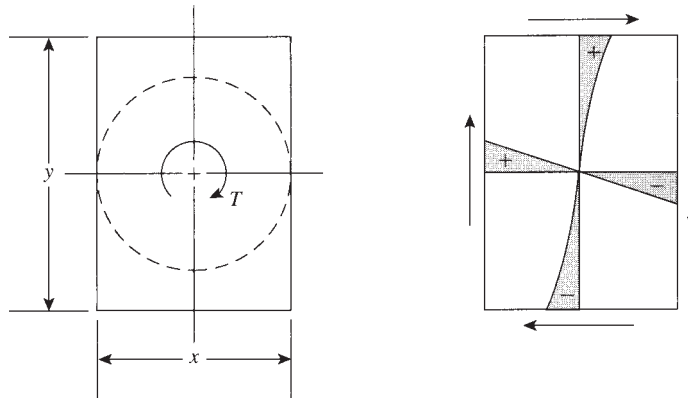
$T$  = applied torque

$x$  = short side of rectangular section

$y$  = long side of rectangular section

$\alpha$  = coefficient that depends on ratio of  $y/x$ ; its value is given in the following table:

$y/x$	1.0	1.2	1.5	2.0	4	10
$\alpha$	0.208	0.219	0.231	0.246	0.282	0.312



**Figure 15.5** Stress distribution in rectangular sections due to pure torsion.

The maximum shearing stress occurs along the centerline of the longer side  $y$  (Fig. 15.5).

For members composed of rectangles, such as T-, L-, or I-sections, the value of  $\alpha$  can be assumed equal to be  $\frac{1}{3}$ , and the section may be divided into several rectangular components having a long side  $y_i$  and a short side  $x_i$ . The maximum shearing stress can be calculated from

$$v_{\max} = \frac{3T}{\sum x_i^2 y_i} \quad (15.6)$$

where  $\sum x_i^2 y_i$  is the value obtained from the rectangular components of the section. When  $y/x \leq 10$ , a better expression may be used:

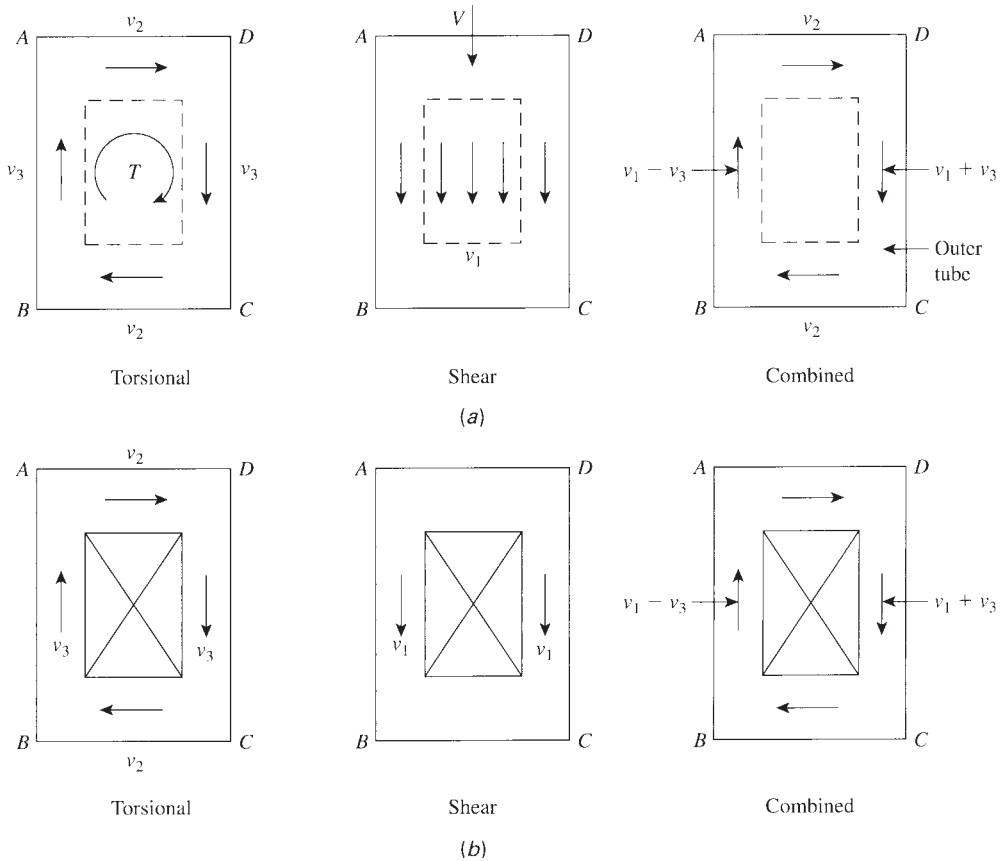
$$v_{\max} = \frac{3T}{\sum x^2 y [1 - 0.63(x/y)]} \quad (15.7)$$

### 15.5 COMBINED SHEAR AND TORSION

In most practical cases, a structural member may be subjected simultaneously to both shear and torsional forces. Shear stresses will be developed in the section, as was explained in Chapter 8, with an average shear  $= v_1$  in the direction of the shear force  $V$  (Fig. 15.6a). The torque  $T$  produces torsional stresses along all sides of the rectangular section  $ABCD$  (Fig. 15.6a), with  $v_3 > v_2$ . The final stress distribution is obtained by adding the effect of both shear and torsion stresses to produce maximum value of  $v_1 + v_3$  on side  $CD$ , whereas side  $AB$  will have a final stress of  $v_1 - v_3$ . Both sides  $AD$  and  $BC$  will be subjected to torsional stress  $v_2$  only. The section must be designed for the maximum  $v = v_1 + v_3$ .

### 15.6 TORSION THEORIES FOR CONCRETE MEMBERS

Various methods are available for the analysis of reinforced concrete members subjected to torsion or simultaneous torsion, bending, and shear. The design methods rely generally on two basic theories: the skew bending theory and the space truss analogy.



**Figure 15.6** Combined shear and torsional stresses: (a) solid sections and (b) hollow sections.

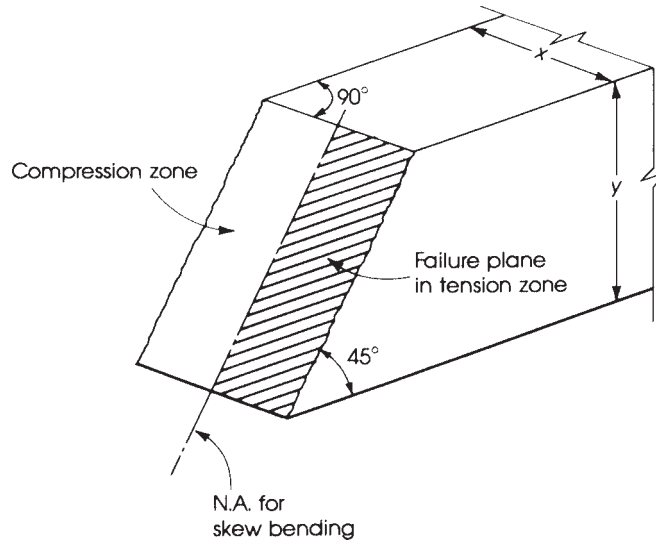
### 15.6.1 Skew Bending Theory

The skew bending concept was first presented by Lessig in 1959 [2] and was further developed by Goode and Helmy [3], Collins et al. in 1968 [4], and Below et al. in 1975 [5]. The concept was applied to reinforced concrete beams subjected to torsion and bending. Expressions for evaluating the torsional capacity of rectangular sections were presented by Hsu in 1968 [6,7] and were adopted by the ACI Code of 1971. Torsion theories for concrete members were discussed by Zia [8]. Empirical design formulas were also presented by Victor et al. in 1976 [9].

The basic approach of the skew bending theory, as presented by Hsu, is that failure of a rectangular section in torsion occurs by bending about an axis parallel to the wider face of the section  $y$  and inclined at about  $45^\circ$  to the longitudinal axis of the beam (Fig. 15.7). Based on this approach, the minimum torsional moment,  $T_n$ , can be evaluated as follows:

$$T_n = \left( \frac{x^2 y}{3} \right) f_r \quad (15.8)$$

where  $f_r$  is the modulus of rupture of concrete;  $f_r$  is assumed to be  $5\sqrt{f'_c}$  in this case, as compared to  $7.5\lambda\sqrt{f'_c}$  adopted by the ACI Code for the computation of deflection in beams.



**Figure 15.7** Failure surface due to skew bending.

The torque resisted by concrete is expressed as follows:

$$T_c = \left( \frac{2.4}{\sqrt{x}} \right) x^2 y \sqrt{f'_c} \quad (15.9)$$

and the torque resisted by torsional reinforcement is

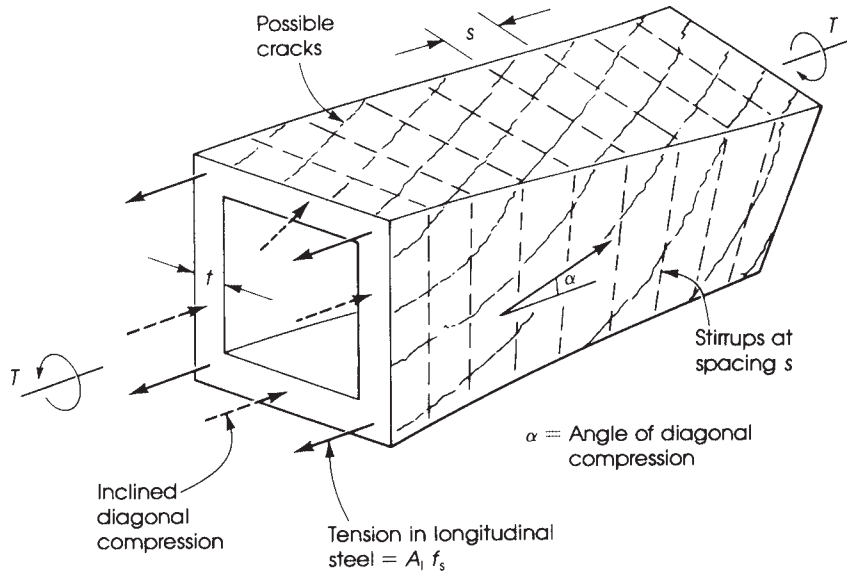
$$T_s = \frac{\alpha_1 (x_1 y_1 A_t f_y)}{s} \quad (15.10)$$

Thus,  $T_n = T_c + T_s$ , where  $T_n$  is the nominal torsional moment capacity of the section.

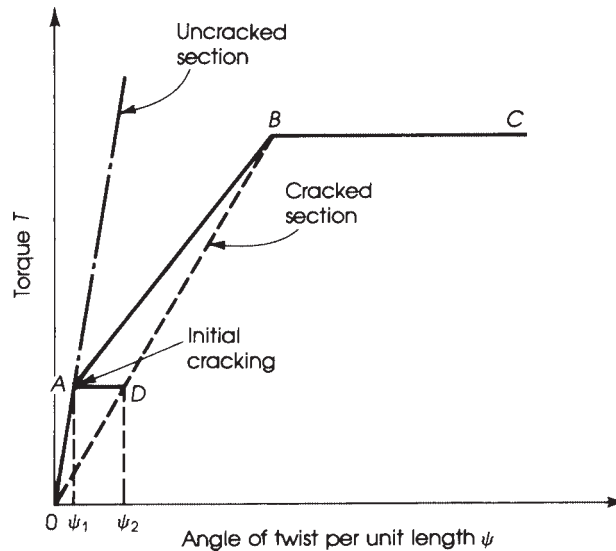
### 15.6.2 Space Truss Analogy

The space truss analogy was first presented by Rausch in 1929 and was further developed by Lampert [10] and Lampert and Thurlimann [11], who supported their theoretical approach with extensive experimental work. The Canadian Code provisions for the design of reinforced concrete beams in torsion and bending are based on the space truss analogy. Mitchell and Collins [12] presented a theoretical model for structural concrete in pure torsion. McMullen and Rangan [13] discussed the design concepts of rectangular sections subjected to pure torsion. In 1983, Solanki [14] presented a simplified design approach based on the theory presented by Mitchell and Collins.

The concept of the space truss analogy is based on the assumption that the torsional capacity of a reinforced concrete rectangular section is derived from the reinforcement and the concrete surrounding the steel only. In this case, a thin-walled section is assumed to act as a space truss (Fig. 15.8). The inclined spiral concrete strips between cracks resist the compressive forces, whereas the longitudinal bars at the corners and stirrups resist the tensile forces produced by the torsional moment.



**Figure 15.8** Forces on section in torsion (space truss analogy).



**Figure 15.9** Idealized torque versus twist relationship.

The behavior of a reinforced concrete beam subjected to pure torsion can be represented by an idealized graph relating the torque to the angle of twist, as shown in Fig. 15.9. It can be seen that, prior to cracking, the concrete resists the torsional stresses and the steel is virtually unstressed. After cracking, the elastic behavior of the beam is not applicable, and hence a sudden change in the angle of twist occurs, which continues to increase until the maximum torsional capacity is reached.



An approximate evaluation of the torsional capacity of a cracked section may be expressed as follows:

$$T_n = 2 \left( \frac{A_t f_y}{s} \right) x_1 y_1 \quad (15.11)$$

where

$A_t$  = area of one leg of stirrups

$s$  = spacing of stirrups

$x_1$  and  $y_1$  = short and long distances, center to center of closed rectangular stirrups or corner bars

The preceding expression neglects the torsional capacity due to concrete. Mitchell and Collins [12] presented the following expression to evaluate the angle of twist per unit length  $\psi$ :

$$\psi = \left( \frac{P_0}{2A_0} \right) \left[ \left( \frac{\epsilon_1}{\tan \alpha} \right) + \left( \frac{P_h (\epsilon_h \tan \alpha)}{P_0} \right) + \frac{2\epsilon_d}{\sin \alpha} \right] \quad (15.12)$$

where

$\epsilon_1$  = strain in longitudinal reinforcing steel

$\epsilon_h$  = strain in hoop steel (stirrups)

$\epsilon_d$  = concrete diagonal strain at position of resultant shear flow

$P_h$  = hoop centerline perimeter

$\alpha$  = angle of diagonal compression =  $(\epsilon_d + \epsilon_1) / [\epsilon_d + \epsilon_h (P_h / P_0)]$

$A_0$  = area enclosed by shear, or  
= torque/2 $q$  where  $q$  = shear flow

$P_0$  = perimeter of shear flow path (perimeter of  $A_0$ )

The preceding twist expression is analogous to the curvature expression in flexure (Fig. 15.10):

$$\phi = \text{curvature} = \frac{\epsilon_c + \epsilon_s}{d_t} \quad (15.13)$$

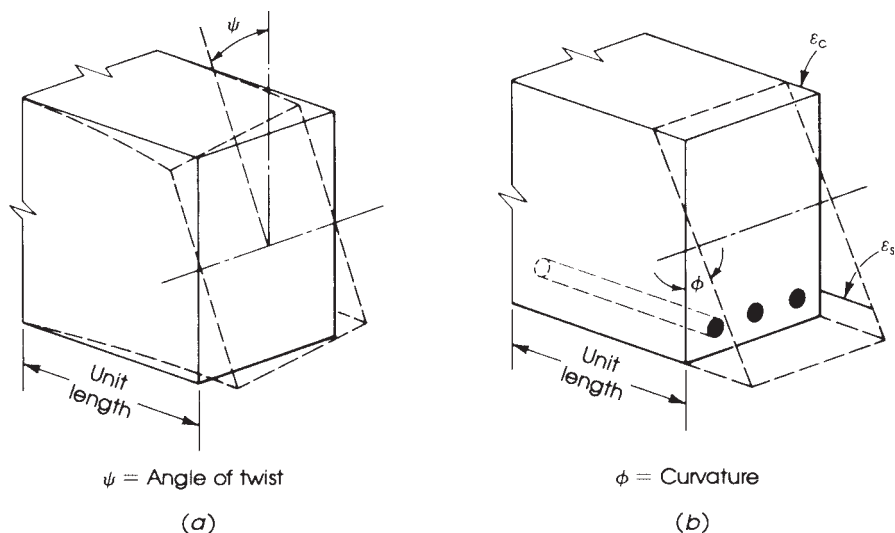


Figure 15.10 (a) Torsion and (b) flexure.

where  $\epsilon_c$  and  $\epsilon_s$  are the strains in concrete and steel, respectively. A simple equation is presented by Solanki [14] to determine the torsional capacity of a reinforced concrete beam in pure torsion, based on the space truss analogy, as follows:

$$T_u = (2A_0) \left[ \left( \frac{\sum A_s f_{sy}}{P_0} \right) \times \left( \frac{A_h f_{hy}}{s} \right) \right]^{1/2} \quad (15.14)$$

where  $A_0$ ,  $P_0$ , and  $s$  are as explained before and

$\sum A_s f_{sy}$  = yield force of all longitudinal steel bars

$A_h f_{hy}$  = yield force of stirrups

The ACI Code adapted this theory to design concrete structural members subjected to torsion or shear and torsion in a simplified approach.

## 15.7 TORSIONAL STRENGTH OF PLAIN CONCRETE MEMBERS

Concrete structural members subjected to torsion will normally be reinforced with special torsional reinforcement. In case the torsional stresses are relatively low and need to be calculated for plain concrete members, the shear stress,  $v_{tc}$ , can be estimated using Eq. 15.6:

$$v_{tc} = \frac{3T}{\phi \sum x^2 y} \leq 6\sqrt{f'_c}$$

and the angle of twist is  $\theta = 3TL/x^3yG$ , where  $T$  is the torque applied on the section (less than the cracking torsional moment) and  $G$  is the shear modulus and can be assumed to be equal to 0.45 times the modulus of elastic of concrete,  $E_c$ ; that is,  $G = 25,700\sqrt{f'_c}$ . The torsional cracking shear,  $v_c$ , in plain concrete may be assumed equal to  $6\sqrt{f'_c}$ . Therefore, for plain concrete rectangular sections,

$$T_c = 2\phi x^2 y \sqrt{f'_c} \quad (15.15)$$

and for compound rectangular sections,

$$T_c = 2\phi \sqrt{f'_c} \sum x^2 y \quad (15.16)$$

## 15.8 TORSION IN REINFORCED CONCRETE MEMBERS (ACI CODE PROCEDURE)

### 15.8.1 General

The design procedure for torsion is similar to that for flexural shear. When the factored torsional moment applied on a section exceeds that which the concrete can resist, torsional cracks develop, and consequently torsional reinforcement in the form of closed stirrups or hoop reinforcement must be provided. In addition to the closed stirrups, longitudinal steel bars are provided in the corners of the stirrups and are well distributed around the section. Both types of reinforcement, closed stirrups and longitudinal bars, are essential to resist the diagonal tension forces caused by torsion; one type will not be effective without the other. The stirrups must be closed, because torsional stresses occur on all faces of the section.

The reinforcement required for torsion must be added to that required for shear, bending moment, and axial forces. The reinforcement required for torsion must be provided such that the torsional moment strength of the section  $\phi T_n$  is equal to or exceeds the applied factored torsional moment  $T_u$  computed from factored loads:

$$\phi T_n \geq T_u \quad (15.17)$$

When torsional reinforcement is required, the torsional moment strength  $\phi T_n$  must be calculated assuming that all the applied torque,  $T_u$ , is to be resisted by stirrups and longitudinal bars with concrete torsional strength,  $T_c = 0$ . At the same time, the shear resisted by concrete,  $v_c$ , is assumed to remain unchanged by the presence of torsion.

### 15.8.2 Torsional Geometric Parameters

In the ACI Code, Section 22.7, the design for torsion is based on the space truss analogy, as shown in Fig. 15.8. After torsional cracking occurs, the torque is resisted by closed stirrups, longitudinal bars, and concrete compression diagonals. The concrete shell outside the stirrups becomes relatively ineffective and is normally neglected in design. The area enclosed by the centerline of the outermost closed stirrups is denoted by  $A_{0h}$ , the shaded area in Fig. 15.11. Because other terms are used in the design equations, they are introduced here first to make the equation easier to comprehend. Referring to Fig. 15.11, the given terms are defined as follows:

- $A_{cp}$  = area enclosed by outside perimeter of concrete section, in.<sup>2</sup>
- $P_{cp}$  = perimeter of concrete gross area,  $A_{cp}$ , in.
- $A_{0h}$  = area enclosed by centerline of outermost closed transverse torsional reinforcement, in.<sup>2</sup> (shaded area in Fig. 15.11)
- $A_0$  = gross area enclosed by shear flow path and may be taken equal to  $0.85A_{0h}$  ( $A_0$  may also be determined from analysis [18,19]).
- $P_h$  = perimeter of concrete of outermost closed transverse torsional reinforcement
- $\Theta$  = angle of compression diagonals between 30° and 60° (may be taken equal to 45° for reinforced concrete members)

In T- and L-sections, the effective overhang width of the flange on one side is limited to the projection of the beam above or below the slab, whichever is greater, but not greater than four times the slab thickness (ACI Code, Sections 9.2.4.4).

### 15.8.3 Cracking Torsional Moment, $T_{cr}$

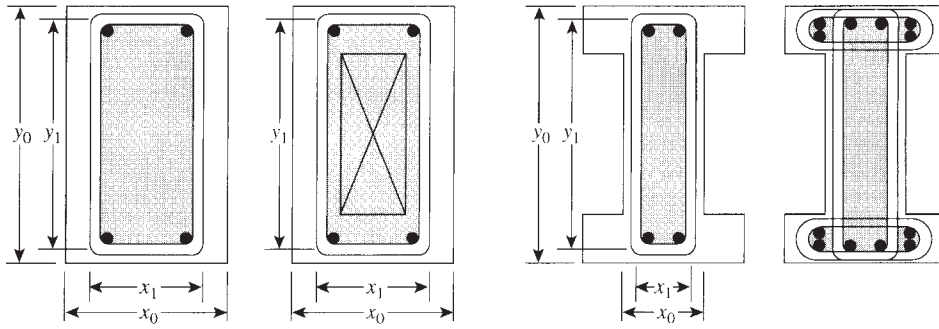
The cracking moment under pure torsion,  $T_{cr}$ , may be derived by replacing the actual section, prior to cracking, with an equivalent thin-walled tube,  $t = 0.75 A_{cp}/P_{cp}$ , and an area enclosed by the wall centerline,  $A_0 = 2 A_{cp}/3$ . When the maximum tensile stress (principal stress) reaches  $4\lambda\sqrt{f'_c}$ , cracks start to occur and the torque  $T$  in general is equal to

$$T = 2A_0\tau t \quad (15.18)$$

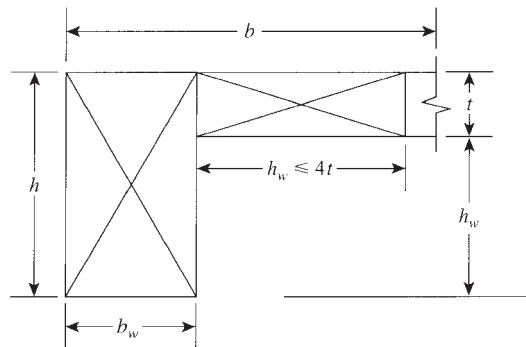
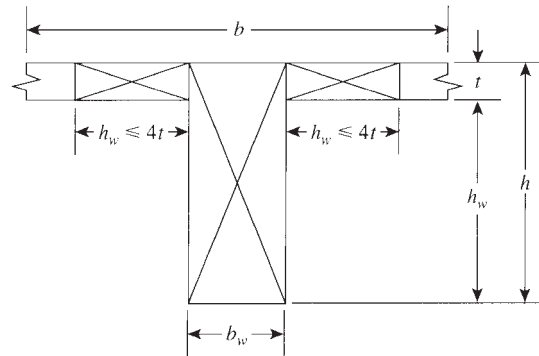
where  $\tau$  is the torsional shear stress, which is  $4\lambda\sqrt{f'_c}$  for torsional cracking.

Replacing  $\tau$  by  $4\lambda\sqrt{f'_c}$ ,

$$T_{cr} = 4\lambda\sqrt{f'_c} \left( \frac{A_{cp}^2}{P_{cp}} \right) = T_n \quad \text{and} \quad T_u = \phi T_{cr} \quad (15.19)$$

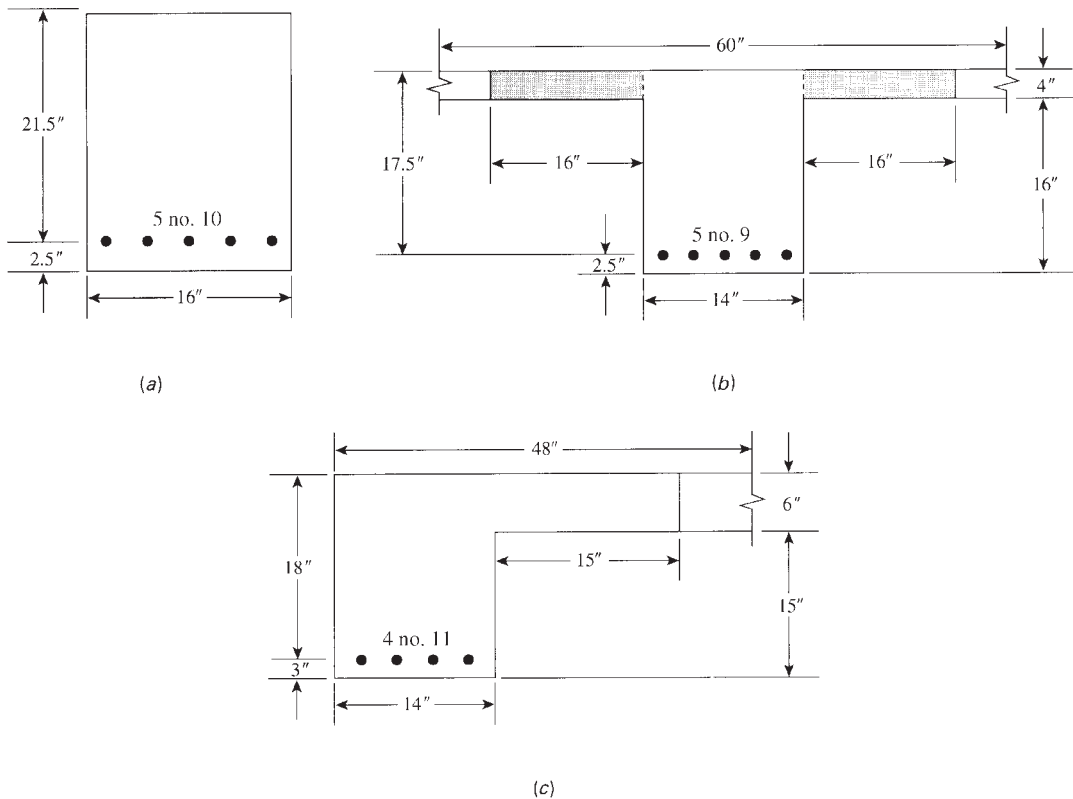


(a)  $A_{ep} = x_0 y_0$ ,  $A_{oh} = x_1 y_1 =$  Shaded area to center of stirrups



(b)

**Figure 15.11** (a) Torsional geometric parameters and (b) effective flange width for T- and L-sections and component rectangles.



**Figure 15.12** Example 15.2.

Assuming that a torque less than or equal to  $T_{cr}/4$  will not cause a significant reduction in the flexural or shear strength in a structural member, the ACI Code, Section 22.7.4, permits neglect of torsion effects in reinforced concrete members when the factored torsional moment  $T_u \leq \phi T_{cr}/4$ , or

$$T_u \leq \phi \lambda \sqrt{f'_c} \left( \frac{A_{cp}^2}{P_{cp}} \right) \quad (15.20)$$

When  $T_u$  exceeds the value in Eq. 15.20, all  $T_u$  must be resisted by closed-stirrup and longitudinal bars. The torque,  $T_u$ , is calculated at a section located at distance  $d$  from the face of the support and  $T_u = \phi T_n$ , where  $\phi = 0.75$ .

### Example 15.2

For the three sections shown in Fig. 15.12, and based on the ACI Code limitations, it is required to compute the following:

- The cracking moment  $\phi T_{cr}$
- The maximum factored torque  $\phi T_n$  that can be applied to each section without using torsional web reinforcement

Assume  $f'_c = 4$  ksi,  $f_y = 60$  ksi, a 1.5-in. concrete cover, and no. 4 stirrups.

**Solution****1. Section 1**

- a. Cracking moment,  $\phi T_{cr}$ , can be calculated from Eq. 15.19:

$$\phi T_{cr} = \phi 4\lambda \sqrt{f'_c} \left( \frac{A_{cp}^2}{P_{cp}} \right)$$

For this section,  $A_{cp} = x_0 y_0$ , the gross area of the section, where  $x_0 = 16$  in. and  $y_0 = 24$  in.

$$A_{cp} = 16(24) = 384 \text{ in.}^2$$

$$P_{cp} = \text{perimeter of gross section}$$

$$= 2(x_0 + y_0) = 2(16 + 24) = 80 \text{ in.}$$

$$\phi T_{cr} = \frac{0.75(4)(1)\sqrt{4000}(384)^2}{80} = 349.7 \text{ K} \cdot \text{in.}$$

- b. The allowable  $\phi T_a$  that can be applied without using torsional reinforcement is computed from Eq. 15.20:

$$T_a = \frac{\phi T_{cr}}{4} = \frac{349.7}{4} = 87.4 \text{ K} \cdot \text{in.}$$

**2. Section 2**

- a. First, calculate  $A_{cp}$  and  $P_{cp}$  for this section and apply Eq. 15.19 to calculate  $\phi T_{cr}$ . Assuming flanges are confined with closed stirrups, the effective flange part to be used on each side of the web is equal to four times the flange thickness, or  $4(4) = 16$  in.  $= h_w = 16$  in.

$$A_{cp} = \text{web area}(b_w h) + \text{area of effective flanges}$$

$$= (14 \times 20) + 2(16 \times 4) = 408 \text{ in.}^2$$

$$P_{cp} = 2(b + h) = 2(14 + 2 \times 16 + 20) = 132 \text{ in.}^2$$

$$\phi T_{cr} = \frac{0.75(4)(1)\sqrt{(4000)}(408)^2}{132} = 239.3 \text{ K} \cdot \text{in.}$$

*Note:* If the flanges are neglected and the torsional reinforcement is confined in the web only, then

$$A_{cp} = 14(20) = 280 \text{ in.}^2 \quad P_{cp} = 2(14 + 20) = 68 \text{ in.} \quad \phi T_{cr} = 219 \text{ K} \cdot \text{in.}$$

- b. The allowable  $\phi T_n$  that can be applied without using torsional reinforcement is:

$$\phi T_n = \frac{\phi T_{cr}}{4} = \frac{239.3}{4} = 59.8 \text{ K} \cdot \text{in.}$$

**3. Section 3**

- a. Assuming flange is confined with closed stirrups, effective flange width is equal to  $b_w = 15$  in.  $< 4 \times 6 = 24$  in.

$$A_{cp} = (14 \times 21) + (15 \times 6) = 384 \text{ in.}^2$$

$$P_{cp} = 2(b + h) = 2(14 + 15 + 21) = 100 \text{ in.}$$

$$\phi T_{cr} = \frac{0.75(4)(1)\sqrt{(4000)}(384)^2}{100} = 279.8 \text{ K} \cdot \text{in.}$$

*Note:* If the flanges are neglected, then  $A_{cp} = 294 \text{ in.}^2$ ,  $P_{cp} = 70 \text{ in.}$ , and  $\phi T_{cr} = 234.3 \text{ K} \cdot \text{in.}$

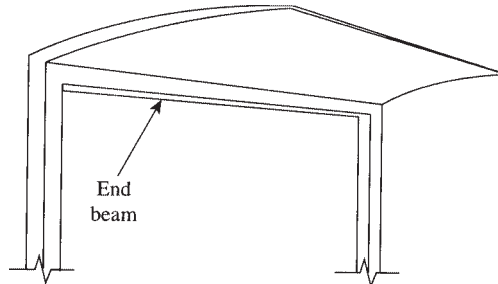
- b. The allowable  $\phi T_n = \frac{\phi T_{cr}}{4} = \frac{279.8}{4} = 70 \text{ K} \cdot \text{in.}$

### 15.8.4 Equilibrium Torsion and Compatibility Torsion

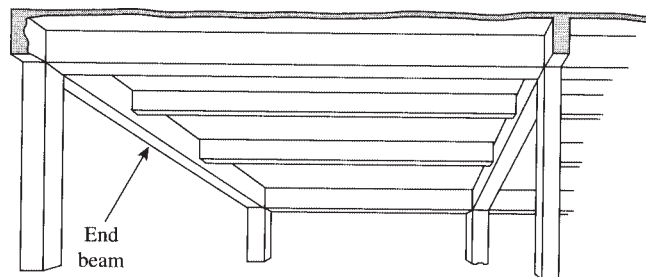
Structural analysis of concrete members gives the different forces acting on the member, such as normal forces, bending moments, shear forces, and torsional moments, as explained in the simple problem of Example 15.1. The design of a concrete member is based on failure of the member under factored loads. In statically indeterminate members, a redistribution of moments occurs before failure; consequently, design moments may be reduced, whereas in statically determinate members, such as a simple beam or a cantilever beam, no moment redistribution occurs.

In the design of structural members subjected to torsional moments two possible cases may apply after cracking.

1. The *equilibrium torsion case* occurs when the torsional moment is required for the structure to be in equilibrium and  $T_u$  cannot be reduced by redistribution of moments, as in the case of simple beams. In this case torsion reinforcement must be provided to resist all of  $T_u$ . Figure 15.13 shows an edge beam supporting a cantilever slab where no redistribution of moments will occur [18,19].
2. The *compatibility torsion case* occurs when the torsional moment,  $T_u$ , can be reduced by the redistribution of internal forces after cracking while compatibility of deformation is maintained in the structural member. Figure 15.14 shows an example of this case, where two transverse beams are acting on an edge beam producing twisting moments. At torsional cracking, a large twist occurs, resulting in a large distribution of forces in the structure [18,19]. The cracking torque,  $T_{cr}$ , under combined flexure, shear, and torsion is reached



**Figure 15.13** Design torque may not be reduced. Moment redistribution is not possible [19].



**Figure 15.14** Design torque may be reduced in a spandrel beam. Moment redistribution is possible [19].

when the principal stress in concrete is about  $4\lambda\sqrt{f'_c}$ . When  $T_u > T_{cr}$ , a torque equal to  $T_{cr}$  Eq. 15.19, may be assumed to occur at the critical sections near the faces of the supports.

The ACI Code limits the design torque to the smaller of  $T_u$  from factored loads or  $\phi T_{cr}$  from Eq. 15.19.

### 15.8.5 Limitation of Torsional Moment Strength

The ACI Code, Section 22.7.7, limits the size of the cross-sectional dimension by the following two equations:

1. For solid sections,

$$\sqrt{\left(\frac{V_u}{b_w d}\right)^2 + \left(\frac{T_u P_h}{1.7 A_{oh}^2}\right)^2} \leq \phi \left[ \left(\frac{V_c}{b_w d}\right) + 8\sqrt{f'_c} \right] \quad (15.21)$$

2. For hollow sections,

$$\left(\frac{V_u}{b_w d}\right) + \left(\frac{T_u P_h}{1.7 A_{oh}^2}\right) \leq \phi \left[ \left(\frac{V_c}{b_w d}\right) + 8\sqrt{f'_c} \right] \quad (15.22)$$

where  $V_c$  equals  $2\lambda\sqrt{f'_c}b_w d$ , which is shear strength for normal-weight concrete. All other terms were defined in Section 15.8.2.

This limitation is based on the fact that the sum of the stresses due to shear and torsion (on the left-hand side) may not exceed the cracking stress plus  $8\sqrt{f'_c}$ . The same condition was applied to the design of shear without torsion in Chapter 5. The limitation is needed to reduce cracking and to prevent crushing of the concrete surface due to inclined shear and torsion stresses.

### 15.8.6 Hollow Sections

Combined shear and torsional stresses in a hollow section are shown in Fig. 15.6, where the wall thickness is assumed constant. In some hollow sections, the wall thickness may vary around the perimeter. In this case, Eq. 15.22 should be evaluated at the location where the left-hand side is maximum. Note that at the top and bottom flanges, the shear stresses are usually negligible. In general, if the wall thickness of a hollow section  $t$  is less than  $A_{oh}/P_h$ , then Eq. 15.22 becomes

$$\frac{V_u}{b_w d} + \frac{T_u}{1.7 A_{oh} t} \leq \phi \left[ \left(\frac{V_c}{b_w d}\right) + 8\sqrt{f'_c} \right] \quad (15.23)$$

(ACI Code, Section 22.7.7).

### 15.8.7 Web Reinforcement

As was explained earlier, the ACI Code approach for the design of the members due to torsion is based on the space truss analogy in Fig. 15.8. After torsional cracking, two types of reinforcement are required to resist the applied torque,  $T_u$ : transverse reinforcement,  $A_t$ , in the form of



closed stirrups, and longitudinal reinforcement,  $A_l$ , in the form of longitudinal bars. The ACI Code, Section 22.7.6.1, presented the following expression to compute  $A_t$  and  $A_l$ :

1. Closed stirrups  $A_t$  can be calculated as follows:

$$T_n = \frac{2A_0A_t f_{yt} \cot \theta}{s} \quad (15.24)$$

where

$$T_n = \frac{T_u}{\phi} \quad \text{and} \quad \phi = 0.75$$

$A_t$  = area of one leg of transverse closed stirrups

$f_{yt}$  = yield strength of  $A_t \leq 60$  ksi

$s$  = spacing of stirrups

And  $A_0$  and  $\theta$  were defined in ACI Section 22.7.6.1. Equation 15.24 can be written as follows:

$$\frac{A_t}{s} = \frac{T_n}{2A_0 f_{yt} \cot \theta} \quad (15.25)$$

If  $\theta = 45^\circ$ , then  $\cot \theta = 1.0$ , and if  $f_{yt} = 60$  ksi, then Eq. 15.25 becomes

$$\frac{A_t}{s} = \frac{T_n}{120A_0} \quad (15.26)$$

where  $T_n$  is in K · in. Spacing of stirrups,  $s$ , should not exceed the smaller of  $P_h/8$  or 12 in. For hollow sections in torsion, the distance measured from the centerline of stirrups to the inside face of the wall shall not be less than  $0.5 A_{0h}/P_h$ .

2. The additional longitudinal reinforcement,  $A_l$ , required for torsion should not be less than the following:

$$A_l = \left( \frac{A_t}{s} \right) P_h \left( \frac{f_{yt}}{f_y} \right) \cot^2 \theta \quad (15.27)$$

If  $\theta = 45^\circ$  and  $f_{yt} = f_y = 60$  ksi for both stirrups and longitudinal bars, then Eq. 15.27 becomes

$$A_l = \left( \frac{A_t}{s} \right) P_h = 2 \left( \frac{A_t}{s} \right) (x_1 + y_1) \quad (15.28)$$

where  $P_h$  is as defined in ACI Section 22.7.6.1. Note that reinforcement required for torsion should be added to that required for the shear, moment, and axial force that act in combination with torsion. Other limitations for the longitudinal reinforcement,  $A_l$ , are as follows:

- a. The smallest bar diameter of a longitudinal bar is that of no. 3 or stirrup spacing  $s/24$ , whichever is greater.
- b. The longitudinal bars should be distributed around the perimeter of the closed stirrups with a maximum spacing of 12 in.
- c. The longitudinal bars must be inside the stirrups with at least one bar in each corner of the stirrups. Corner bars are found to be effective in developing torsional strength and in controlling cracking.
- d. Torsional reinforcement should be provided for a distance  $(b_t + d)$  beyond the point theoretically required, where  $b_t$  is the width of that part of the cross section containing the stirrups resisting torsion.

### 15.8.8 Minimum Torsional Reinforcement

Where torsional reinforcement is required, the minimum torsional reinforcement may be computed as follows (ACI Code, Section 9.6.4.2):

1. Minimum transverse closed stirrups for combined shear and torsion (see Section 8.6):

$$A_v + 2A_t \geq 0.75\sqrt{f'_c} \left( \frac{b_w s}{f_{yt}} \right)$$

But shall not be less than  $\frac{50b_w s}{f_{yt}}$  (15.29)

where

- $A_v$  = area of two legs of closed stirrup determined from shear
- $A_t$  = area of one leg of closed stirrup determined from torsion
- $s$  = spacing of stirrups
- $f_{yt}$  = yield strength of closed stirrups  $\leq 60$  ksi

Spacing of stirrups,  $s$ , should not exceed  $P_h/8$  or 12 in., whichever is smaller. This spacing is needed to control cracking width.

2. Minimum total area of longitudinal torsional reinforcement:

$$A_{l,\min} = \left( \frac{5\sqrt{f'_c} A_{cp}}{f_y} \right) - \left( \frac{A_t}{s} \right) P_h \left( \frac{f_{yt}}{f_y} \right) \quad (15.30)$$

where  $f_y$  is the yield strength of longitudinal torsional reinforcement. Also  $A_t/s$  shall not be taken less than  $25 b_w/f_{yt}$ .

The minimum  $A_l$  in Eq. 15.30 was determined to provide a minimum ratio of the volume of torsional reinforcement to the volume of concrete of about 1% for reinforced concrete subjected to pure torsion.

## 15.9 SUMMARY OF ACI CODE PROCEDURES

The design procedure for combined shear and torsion can be summarized as follows:

1. Calculate the factored shearing force,  $V_u$ , and the factored torsional moment,  $T_u$ , from the applied forces on the structural member. Critical values for shear and torsion are at a section distance  $d$  from the face of the support.
2. a. Shear reinforcement is needed when  $V_u > \phi V_c/2$ , where  $V_c = 2\lambda\sqrt{f'_c}b_w d$   
 b. Torsional reinforcement is needed when

$$T_u > \phi\lambda\sqrt{f'_c} \left( \frac{A_{cp}^2}{P_{cp}} \right) \quad (\text{Eq. 15.20})$$

If web reinforcement is needed, proceed as follows.

**3. Design for shear:**

- a.** Calculate the nominal shearing strength provided by the concrete,  $V_c$ . Determine the shear to be carried by web reinforcement:

$$V_u = \phi V_c + \phi V_s \quad \text{or} \quad V_s = \frac{V_u - \phi V_c}{\phi}$$

- b.** Compare the calculated  $V_s$  with maximum permitted value of  $(8\sqrt{f'_c}b_wd)$  according to the ACI Code, Section 22.5.1.2. If calculated  $V_s$  is less, proceed with the design; if not, increase the dimensions of the concrete section.
- c.** The shear web reinforcement is calculated as follows:

$$A_v = \frac{V_s s}{f_{yt} d}$$

where

$A_v$  = area of two legs of the stirrup  
 $s$  = spacing of stirrups

The shear reinforcement per unit length of beam is

$$\frac{A_v}{s} = \frac{V_s}{f_{yt} d}$$

- d.** Check  $A_v/s$  calculated with the minimum  $A_v/s$ :

$$(\min) \frac{A_v}{s} = 0.75 \sqrt{f'_c} \left( \frac{b_w}{f_{yt}} \right) \geq 50 \left( \frac{b_w}{f_{yt}} \right)$$

The minimum  $A_v$ , specified by the code under the combined action of shear and torsion, is given in step 5.

**4. Design for torsion:**

- a.** Check if the factored torsional moment,  $T_u$ , causes equilibrium or compatibility torsion. For equilibrium torsion, use  $T_u$ . For compatibility torsion, the design torsional moment is the smaller of  $T_u$  from factored load and

$$T_{u2} = \phi 4 \lambda \sqrt{f'_c} \left( \frac{A_{cp}^2}{P_{cp}} \right) \quad (\text{Eq. 15.29})$$

- b.** Check that the size of the section is adequate. This is achieved by checking either Eq. 15.21 for solid sections or Eq. 15.22 for hollow sections. If the left-hand-side value is greater than  $\phi(V_c/b_wd + 8\sqrt{f'_c})$ , then increase the cross-section. If it is less than that value, proceed. For hollow sections, check if the wall thickness  $t$  is less than  $A_{0h}/P_h$ . If it is less, use Eq. 15.23 instead of Eq. 15.22; otherwise, use Eq. 15.25.
- c.** Determine the closed stirrups required from Eq. 15.25:

$$\frac{A_t}{s} = \frac{T_n}{2A_0 f_{yt} \cot \theta} \quad (\text{Eq. 15.25})$$

and  $A_t/s$  should not be less than  $25 b_w/f_{yt}$ . Also, the angle  $\theta$  may be assumed to be  $45^\circ$ ,  $T_n = T_u/\phi$ , and  $\phi = 0.75$ .

Assume  $A_0 = 0.85 A_{0h} = 0.85 (x_1 y_1)$ , where  $x_1$  and  $y_1$  are the width and depth of the section to the centerline of stirrups; see Fig. 15.11. Values of  $A_0$  and  $\theta$  may be obtained from analysis [18]. For  $\theta = 45^\circ$  and  $f_y = 60$  ksi,

$$\frac{A_t}{s} = \frac{T_n}{120A_0} \quad (\text{Eq. 15.26})$$

The maximum allowable spacing,  $s$ , is the smaller of 12 in. or  $P_h/8$ .

- d. Determine the additional longitudinal reinforcement:

$$A_l = \left( \frac{A_t}{s} \right) P_h \left( \frac{f_{yt}}{f_y} \right) \cot^2 \theta \quad (\text{Eq. 15.27})$$

but not less than

$$A_{l,\min} = \left( \frac{5\sqrt{f'_c} A_{cp}}{f_y} \right) - \left( \frac{A_t}{s} \right) P_h \left( \frac{f_{yt}}{f_y} \right) \quad (\text{Eq. 15.30})$$

For  $\theta = 45^\circ$  and  $f_{yt} = 60$  ksi, then  $A_l = (A_t/s)P_h$ .

Bars should have a diameter of at least stirrup spacing,  $s/24$ , but not less than no. 3 bars. The longitudinal bars should be placed inside the closed stirrups with maximum spacing of 12 in. At least one bar should be placed at each corner of stirrups. Normally, one-third of  $A_l$  is added to the tension reinforcement, one-third at midheight of the section, and one-third at the compression side.

5. Determine the total area of closed stirrups due to  $V_u$  and  $T_u$ .

$$A_{vt} = (A_u + 2A_t) \geq \frac{50b_w s}{f_{yt}} \quad (\text{Eq. 15.29})$$

Choose proper closed stirrups with a spacing  $s$  as the smaller of 12 in. or  $P_h/8$ .

The stirrups should be extended a distance  $(b_t + d)$  beyond the point theoretically no longer required, where  $b_t$  is the width of cross section resisting torsion.

### Example 15.3 Equilibrium Torsion

Determine the necessary web reinforcement for the rectangular section shown in Fig. 15.15. The section is subjected to a factored shear  $V_u = 48$  K and an equilibrium torsion  $T_u = 360$  K · in at a section located at a distance  $d$  from the face of the support. Use normal-weight concrete with  $f'_c = 4$  ksi and  $f_y = 60$  ksi.

#### Solution

The following steps explain the design procedure:

1. Design forces are  $V_u = 48$  K and an equilibrium torsion  $T_u = 360$  K · in.
2. a. Shear reinforcement is needed when  $V_u > \phi V_c/2$ .

$$\phi V_c = \phi 2\lambda \sqrt{f'_c} b d = 0.75(2)(1)\sqrt{4000}(16)(20.5) = 31.1 \text{ K}$$

$$V_u = 48 \text{ K} > \frac{\phi V_c}{2} = 15.55 \text{ K}$$

Shear reinforcement is required.

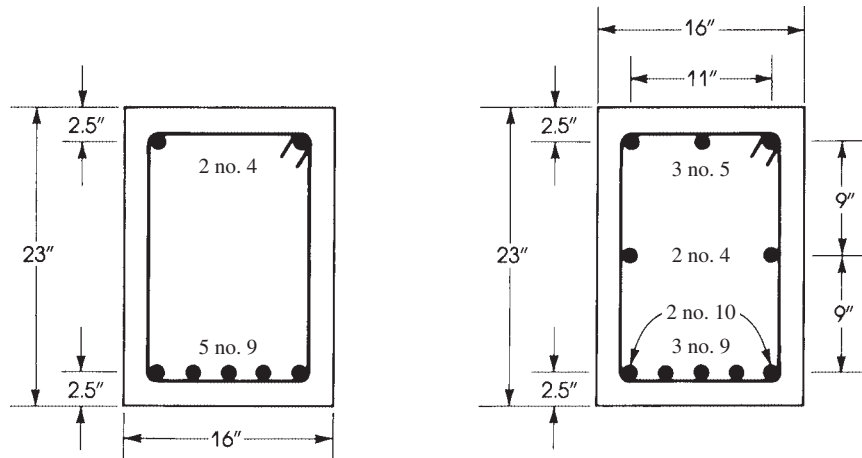


Figure 15.15 Example 15.3.

- b. Torsional reinforcement is needed when

$$T_u > \phi \lambda \sqrt{f'_c} \left( \frac{A_{cp}^2}{P_{cp}} \right) = T_a$$

where

$$A_{cp} = x_0 y_0 = 16(23) = 368 \text{ in.}^2$$

$$P_{cp} = 2(x_0 + y_0) = 2(16 + 23) = 78 \text{ in.}$$

$$T_a = \frac{0.75(1)\sqrt{4000}(368)^2}{78} = 82.36 \text{ K} \cdot \text{in.}$$

$$T_u = 360 \text{ K} \cdot \text{in.} > 82.36 \text{ K} \cdot \text{in.} \quad (\text{Eq. 15.20})$$

Torsional reinforcement is needed. Note that if  $T_u$  is less than  $82.36 \text{ K} \cdot \text{in.}$ , torsional reinforcement is not required, but shear reinforcement may be required.

3. Design for shear:

a.  $V_u = \phi V_c + \phi V_s$ ,  $\phi V_c = 48 = 31.1 + 0.75 V_s$ ,  $V_s = 22.5 \text{ K.}$

b. Maximum  $V_s = 8\sqrt{f'_c}bd = 8\sqrt{4000}(16)(20.5) = 166 \text{ K} > V_s$ .

c.  $A_v / s = V_s / f_y d = 22.5 / (60 \times 20.5) = 0.018 \text{ in.}^2 / \text{in.}$  (two legs).  $A_v / 2s = 0.018 / 2 = 0.009 \text{ in.}^2 / \text{in.}$  (one leg).

4. Design for torsion:

- a. Design  $T_u = 360 \text{ K} \cdot \text{in.}$  Determine sectional properties, assuming 1.5 in. concrete cover and no. 4 stirrups:

$$x_1 = \text{width to center of stirrups} = 16 - 2(1.5 + 0.25) = 12.5 \text{ in.}$$

$$y_1 = \text{depth to center of stirrups} = 23 - 2(1.5 + 0.25) = 19.5 \text{ in.}$$

Practically,  $x_1$  can be assumed to be  $b - 3.5 \text{ in.}$  and  $y_1 = h - 3.5 \text{ in.}$

$$A_{0h} = x_1 y_1 = (12.5 \times 19.5) = 244 \text{ in.}^2$$

$$A_0 = 0.85 A_{0h} = 207.2 \text{ in.}^2$$

$$P_h = 2(x_1 + y_1) = 2(12.5 + 19.5) = 64 \text{ in.}$$

For  $\theta = 45^\circ$  and  $\cot \theta = 1.0$ .

- b. Check the adequacy of the size of the section using Eq. 15.21:

$$\sqrt{\left(\frac{V_u}{b_w d}\right)^2 + \left(\frac{T_u P_h}{1.7 A_{oh}^2}\right)^2} \leq \phi \left[ \left(\frac{V_c}{b_w d}\right) + 8\sqrt{f'_c} \right]$$

$$\phi V_c = 31.1 \text{ K} \quad \text{and} \quad V_c = 41.5 \text{ K}$$

$$\text{Left - handside} = \sqrt{\left(\frac{48,000}{16 \times 20.5}\right)^2 + \left(\frac{360,000 \times 64}{1.7(244)^2}\right)^2} = 271 \text{ psi}$$

$$\text{Right - handside} = 0.75 \left( \frac{41,500}{16 \times 20.5} + 8\sqrt{4000} \right) = 475 \text{ psi} > 271 \text{ psi}$$

The section is adequate.

- c. Determine the required closed stirrups due to torsion from Eq. 15.25:

$$\frac{A_t}{s} = \frac{T_n}{2A_0 f_{yt} \cot \theta}$$

$$T_n = \frac{T_u}{\phi} = \frac{360}{0.75} = 480 \text{ K} \cdot \text{in.} \quad \cot \theta = 1.0 \quad \text{and} \quad A_0 = 207.2 \text{ in.}^2$$

$$\frac{A_t}{s} = \frac{480}{2 \times 207.2 \times 60} = 0.019 \text{ in.}^2/\text{in.} \quad (\text{per one leg})$$

- d. Determine the additional longitudinal reinforcement from Eq. :

$$A_l = \left(\frac{A_t}{s}\right) P_h \left(\frac{f_{yt}}{f_y}\right) \cot^2 \theta$$

$$\frac{A_t}{s} = 0.019 \quad P_h = 64 \text{ in.} \quad f_{yt} = f_y = 60 \text{ ksi} \quad \cot \theta = 1.0$$

$$A_l = 0.019(64) = 1.21 \text{ in.}^2$$

$$\text{Min. } A_l = \frac{5\sqrt{f'_c} A_{cp}}{f_y} - \left(\frac{A_t}{s}\right) P_h \left(\frac{f_{yt}}{f_y}\right)$$

$$A_{cp} = 368 \text{ in.}^2 \quad \frac{A_t}{s} = 0.019$$

$$f_{yt} = f_{y1} = 60 \text{ ksi}$$

$$\text{Min. } A_l = \left[ \frac{5\sqrt{4000}(368)}{60,000} \right] - (0.019 \times 64 \times 1.0) = 0.72 \text{ in.}^2$$

$$A_l = 1.21 \text{ in.}^2 \text{ controls}$$

5. Determine total area of closed stirrups:

- a. For one leg of stirrups,  $A_{vt}/s = A_t/s + A_v/2s$ .

$$\text{Required } A_{vt} = \frac{0.018}{2} + 0.019 = 0.028 \text{ in.}^2/\text{in.} \quad (\text{per one leg})$$

Using no. 4 stirrups, the area of one leg is  $0.2 \text{ in.}^2$

$$\text{Spacing of stirrups} = \frac{0.2}{0.028} = 7.14 \text{ in.} \quad \text{or} \quad 7.0 \text{ in.}$$

- b. Maximum  $s = P_h/8 = \frac{64}{8} = 8$  in. or 12 in., whichever is smaller. The value of  $s$  used is 7.0 in. < 8 in.
- c. Minimum  $A_{vt}/s = 50 b_w/f_{yt} = 50(16)/60,000 = 0.0133$  in.<sup>2</sup>/in. This is less than 0.028 in.<sup>2</sup>/in. provided.
6. To find the distribution of longitudinal bars, note that total  $A_l = 1.21$  in.<sup>2</sup>. Use one-third at the top, or  $1.21/3 = 0.4$  in.<sup>2</sup>, to be added to the compression steel  $A'_s$ . Use one-third, or 0.4 in.<sup>2</sup>, at the bottom, to be added to the tension steel, and one-third, or 0.4 in.<sup>2</sup>, at middepth.
- a. The total area of top bars is  $0.4$  (two no. 4) +  $0.4 = 0.8$  in.<sup>2</sup> use three no. 5 bars ( $A_s = 0.91$  in.<sup>2</sup>).
- b. The total area of bottom bars is  $5$  (five no. 9) +  $0.4 = 5.4$  in.<sup>2</sup>; use three no. 9 and two no. 10 bars at the corners (total  $A_s = 5.53$  in.<sup>2</sup>).
- c. At middepth, use two no. 4 bars ( $A_s = 0.4$  in.<sup>2</sup>). Reinforcement details are shown in Fig. 15.15. Spacing of longitudinal bars is equal to 9 in., which is less than the maximum required of 12 in. The diameter of no. 4 bars used is greater than the minimum of no. 3 or stirrup spacing, or  $s/24 = 0.21$  in.

#### Example 15.4 Compatibility Torsion

Repeat Example 15.3 if the factored torsional torque is a compatibility torsion.

#### Solution

Referring to the solution of Example 15.3:

- Design forces are  $V_u = 48$  K and compatibility torsion is  $360$  K · in.
- Steps (a) and (b) are the same as in Example 15.3. Web reinforcement is required.
- Step (c) is the same.
- Design for torsion:  
Because this is a compatibility torsion of  $360$  K · in., the design  $T_u$  is the smaller of  $360$  K · in. or  $\phi T_{cr}$  given in Eq. 15.19.

$$\phi T_{cr} = \phi 4 \lambda \sqrt{f'_c} \left( \frac{A_{cp}^2}{P_{cp}} \right) = \frac{0.75(4)(1)\sqrt{4000}(368)^2}{78} = 329.4 \text{ K} \cdot \text{in.} \quad (\text{Eq. 15.19})$$

Because  $\phi T_{cr} < 360$  K · in., use  $T_u = 329.4$  K · in. Repeat all the steps of Example 15.3 using  $T_u = 329.3$  K · in. to determine that the section is adequate.

$$\frac{A_l}{s} = 0.018 \text{ in.}^2/\text{in.} \quad (\text{one leg})$$

$$A_l = 0.018(64) = 1.152 \text{ in.}^2$$

Use  $1.2 \text{ in.}^2 > \text{min. } A_l$ .

- Required  $A_{vt} = 0.018/2 + 0.018 = 0.027$  in.<sup>2</sup>/in. (one leg).

$$s = \frac{0.2}{0.027} = 7.4 \text{ in.}$$

Use 7 in. Choose bars, stirrups, and spacing similar to Example 15.3.

#### Example 15.5 L-Section with Equilibrium Torsion

The edge beam of a building floor system is shown in Fig. 15.16. The section at a distance  $d$  from the face of the support is subjected to  $V_u = 53$  K and an equilibrium torque  $T_u = 240$  K · in. Design the necessary web reinforcement using  $f'_c = 4$  ksi and  $f_y = 60$  ksi for all steel bars and stirrups.

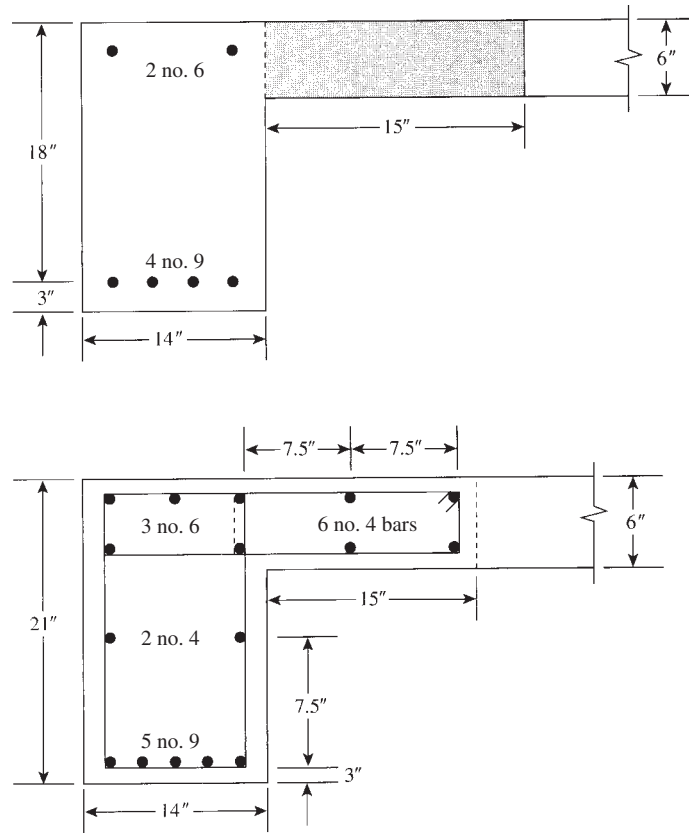


Figure 15.16 Example 15.5.

### Solution

- Design forces are  $V_u = 53$  K and  $T_u = 240$  K · in. = 20 K · ft.
- a. Shear reinforcement is needed when  $V_u > \phi V_c/2$ .

$$\phi V_c = \phi 2\lambda\sqrt{f'_c}b_wd = 0.75(2)(1)\sqrt{4000}(14)(18) = 23.9 \text{ K}$$

$$V_u > \frac{\phi V_c}{2} = 11.95 \text{ K}$$

Shear reinforcement is required.

- b. Check if torsional reinforcement is needed. Assuming that flange is contributing to resist torsion, the effective flange length is  $h_w = 15$  in.  $< 4 \times 6 = 24$  in.

$$x_0 = 14 \text{ in. and } y_0 = 21 \text{ in.}$$

$$A_{cp} = (14 \times 21)(\text{web}) + (15 \times 6)(\text{flange}) = 384 \text{ in.}^2$$

$$P_{cp} = 2(21 + 29) = 100 \text{ in.}$$

$$T_a(\text{Eq. 15.20}) = \frac{0.75(1)\sqrt{4000}(384)^2}{100} = 70 \text{ K} \cdot \text{in.}$$

$$T_u > T_a$$

Torsional reinforcement is required.



## 3. Design for shear:

a.

$$V_u = \phi V_c + \phi V_s$$

$$53 = 23.9 + 0.75 V_s$$

$$V_s = 38.8 \text{ K}$$

b. Maximum  $V_s = 8\sqrt{f'_c}b_w d = 127.5 \text{ K} > V_s$ 

c.

$$\frac{A_v}{s} = \frac{V_s}{f_y d} = \frac{38.8}{60 \times 18} = 0.036 \text{ in.}^2/\text{in.} \quad (\text{two legs})$$

$$\frac{A_v}{2s} = \frac{0.036}{2} = 0.018 \text{ in.}^2/\text{in.}$$

4. Design for torsion:  $T_u = 240 \text{ K} \cdot \text{in.}$ 

a. Determine section properties assuming a concrete cover of 1.5 in. and no. 4 stirrups:

$$\text{Web } x_1 = b - 3.5 \text{ in.} = 14 - 3.5 = 10.5 \text{ in.} \quad y_1 = h - 3.5 = 21 - 3.5 = 17.5 \text{ in.}$$

$$\text{Flange } x_1 = 15 \text{ in. (stirrups extend to the web)} \quad y_1 = 6 - 3.5 = 2.5 \text{ in.}$$

$$A_{0h} = (15 \times 2.5) + (10.5 \times 17.5) = 221 \text{ in.}^2 \quad A_0 = 0.85 A_{0h} = 188 \text{ in.}^2$$

$$P_h = 2(15 + 2.5) + 2(10.5 + 17.5) = 91 \text{ in.} \quad \theta = 45^\circ \quad \cot \theta = 1.0$$

b. Check the adequacy of the section using Eq. 15.21:  $V_u = 53 \text{ K}$ ,  $\phi V_c = 23.9 \text{ K}$ ,  $V_c = 31.9 \text{ K}$ , and  $T_u = 240 \text{ K} \cdot \text{in.}$ 

$$\text{Left-handside} = \sqrt{\left(\frac{53,000}{14 \times 18}\right)^2 + \left[\frac{240,000 \times 91}{1.7(184)^2}\right]^2} = 434 \text{ psi}$$

$$\text{Right-handside} = 0.75 \left[ \frac{31,900}{14 \times 18} + 8\sqrt{4000} \right] = 475 \text{ psi}$$

c. Determine the torsional closed stirrups,  $A_t/s$ , from Eq. 15.25:

$$\frac{A_t}{s} = \frac{T_n}{2A_0 f_{yt}} = \frac{240}{0.75 \times 2 \times 188 \times 60} = 0.014 \text{ in.}^2/\text{in.} \quad (\text{for one leg})$$

d. Calculate the additional longitudinal reinforcement from Eq. 15.28 (for  $f_y = 60 \text{ ksi}$  and  $\cot \theta = 1.0$ ):

$$A_l = \left(\frac{A_t}{s}\right) P_h = 0.014(91) = 1.28 \text{ in.}^2$$

 $A_{l,\min}$  (from Eq. 15.30) is

$$A_l = \left[ \frac{5\sqrt{4000}(384)}{60,000} \right] - (0.014 \times 91) = 0.75 \text{ in.}^2$$

The contribution of the flange may be neglected with slight a difference in results and less labor cost.

## 5. Determine the total area of the closed stirrups.

a. For one leg,  $A_{vt}/s = A_t/s + A_v/2s$ .

$$\text{Required } A_{vt} = 0.014 + 0.018 = 0.032 \text{ in.}^2/\text{in.} \quad (\text{per leg})$$

Choose no. 4 closed stirrups, area =  $0.2 \text{ in.}^2$ 

$$\text{Spacing of stirrups} = \frac{0.2}{0.032} = 6.25 \text{ in.}$$

Use 6 in.

- b. Max.  $s = P_h/8 = 91/8 = 11.4$  in. Use  $s = 6$  in., as calculated.
- c.  $A_{vt}/s = 50b_w/f_{yt} = 50(14)/60,000 = 0.017$  in.<sup>2</sup>/in., which is less than the 0.032 in.<sup>2</sup>/in. used. Use no. 4 closed stirrups spaced at 6 in.
6. Find the distribution of longitudinal bars. Total  $A_l$  is 1.28 in.<sup>2</sup>. Use one-third, or 0.43 in.<sup>2</sup>, at the top, at the bottom, and at middepth.
- a. Total top bars = 0.88 + 0.43 = 1.31 in.<sup>2</sup>; use three no. 6 bars (1.32 in.<sup>2</sup>).
- b. Total bottom bars = 4.0 + 0.43 = 4.43 in.<sup>2</sup>; use five no. 9 bars (5.0 in.<sup>2</sup>). Total  $A_l$  used = (1.32 - 0.88) + (5 - 4) = 1.44 in.<sup>2</sup>
- c. Use two no. 4 bars at middepth (0.40 in.<sup>2</sup>). Reinforcement details are shown in Fig. 15.16. Spacing of longitudinal bars is at 7.5 in. < 12 in. The diameter of no. 4 bars used is 0.5 in., which is greater than no. 3 or stirrup spacing,  $s/24 = \frac{6}{24} = 0.25$  in. Add no. 4 longitudinal bars on all corners of closed stirrups in beam web and flange.

## SUMMARY

### Sections 15.1–15.7

1. Torsional stresses develop in a beam when a moment acts on the beam section parallel to its surface.
2. In most practical cases, a structural member may be subjected to combined shear and torsional moments.
3. The design methods for torsion rely generally on two basic theories: the skew bending theory and the space truss theory. The ACI Code adopted the space truss theory.

### Sections 15.8 and 15.9

A summary of the relative equations in U.S. customary units and SI units is given here.

Note that  $(1.0\sqrt{f'_c})$  in psi is equivalent to  $(0.08\sqrt{f'_c})$  in MPa  $\text{N}/\text{mm}^2$ , 1 in.  $\approx 25$  mm, and  $f_{yt} \leq 400$  MPa.

Equation	U.S. Customary Units	SI Units
15.16	$T_c = 2\phi\sqrt{f'_c} \sum x^2y$	$T_c = 0.17\phi\sqrt{f'_c} \sum x^2y$
15.17	$\phi T_n \geq T_u$	Same
15.19	$T_{cr} = 4\lambda\sqrt{f'_c} \left( \frac{A_{cp}^2}{P_{cp}} \right)$	$T_{cr} = (\lambda\sqrt{f'_c}/3)(A_{cp}^2/P_{cp})$
15.20	$T_u = \phi\lambda\sqrt{f'_c} \left( \frac{A_{cp}^2}{P_{cp}} \right)$	$T_u \leq \phi\lambda(\sqrt{f'_c}/12)(A_{cp}^2/P_{cp})$
15.21	$\sqrt{\left(\frac{V_u}{b_w d}\right)^2 + \left(\frac{T_u P_h}{1.7A_{0h}^2}\right)^2} \leq \phi \left[ \left(\frac{V_c}{b_w d}\right) + 8\sqrt{f'_c} \right]$	(U.S.)
	$\sqrt{\left(\frac{V_u}{b_w d}\right)^2 + \left(\frac{T_u P_h}{1.7A_{0h}^2}\right)^2} \leq \phi \left[ \left(\frac{V_c}{b_w d}\right) + (2\sqrt{f'_c}/3) \right]$	(SI)

Equation	U.S. Customary Units	SI Units
15.24	$T_n = \frac{2A_0 A_t f_{yt} \cot \theta}{s}$	Same
(Note that $f_{yt}$ is in MPa, $S$ is in mm, $A_0$ and $A_t$ are in mm <sup>2</sup> , and $T_n$ is in kN m.)		
15.25	$\frac{A_t}{s} = \frac{T_n}{2A_0 f_{yt} \cot \theta}$	Same
15.27	$A_t = \frac{A_t P_h (f_{yt}/f_y) \cot^2 \theta}{s}$	Same
15.29	$A_v + 2A_t \geq \frac{50b_w s}{f_{yt}}$	$(A_v + 2A_t) \geq 0.35 b_w s / f_{yt}$
15.30	$A_{l,\min} = \frac{5\sqrt{f'_c} A_{cp}}{f_y}$	$A_{l,\min} = \frac{5\sqrt{f'_c} A_{cp}}{12f_y}$
	$- \left( \frac{A_t}{s} \right) P_h \left( \frac{f_{yt}}{f_y} \right)$	$- \left( \frac{A_t}{s} \right) P_h \left( \frac{f_{yt}}{f_y} \right)$

## REFERENCES

1. S. Timoshenko and J. N. Goodier. *Theory of Elasticity*. McGraw-Hill, New York, 1951.
2. N. N. Lessig. *The Determination of the Load-Bearing Capacity of Reinforced Concrete Elements with Rectangular Sections Subjected to Flexure and Torsion*. Work No. 5, 1959. Concrete and Reinforced Concrete Institute, Moscow. Translation: Foreign Literature Study No. 371, PCA Research and Development Laboratories, Skokie, IL.
3. C. D. Goode and M. A. Helmy. "Ultimate Strength of Reinforced Concrete Beams Subjected to Combined Torsion and Bending." In *Torsion of Structural Concrete*. Special Publication 18. American Concrete Institute, Detroit, MI, 1968.
4. M. P. Collins, P. F. Walsh, F. E. Archer, and A. S. Hall. "Ultimate Strength of Reinforced Concrete Beams Subjected to Combined Torsion and Bending." In *Torsion of Structural Concrete*. Special Publication 18. American Concrete Institute, Detroit, MI, 1968.
5. K. D. Below, B. V. Rangan, and A. S. Hall. "Theory for Concrete Beams in Torsion and Bending." *Journal of Structural Division*, ASCE, no. 98 (August 1975).
6. T. C. Hsu. "Ultimate Torque of Reinforced Concrete Beams." *Journal of Structural Division*, ASCE, no. 94 (February 1968).
7. T. C. Hsu. "Torsion of Structural Concrete—A Summary of Pure Torsion." In *Torsion of Structural Concrete*. Special Publication 18. American Concrete Institute, Detroit, MI, 1968.
8. P. Zia. "Torsion Theories for Concrete Members." In *Torsion of Structural Concrete*. Special Publication 18. American Concrete Institute, Detroit, MI, 1968.
9. J. Victor, N. Lakshmanan, and N. Rajagopalan. "Ultimate Torque of Reinforced Concrete Beams." *Journal of Structural Division*, ASCE, no. 102 (July 1976).
10. P. Lampert. *Postcracking Stiffness of Reinforced Concrete Beams in Torsion and Bending*. Special Publication 35. American Concrete Institute, Detroit, MI, 1973.
11. P. Lampert and B. Thurlimann. *Ultimate Strength and Design of Reinforced Concrete Beams in Torsion and Bending*. Publication No. 31-I, International Association for Bridge and Structural Engineering, London, 1971.
12. D. Mitchell and M. P. Collins. *The Behavior of Structural Concrete Beams in Pure Torsion*. Publication No. 74-06. Department of Civil Engineering, University of Toronto, 1974.

13. A. E. McMullen and V. S. Rangan. "Pure Torsion on Rectangular Sections, a Reexamination." *ACI Journal* 75 (October 1978).
14. H. T. Solanki. "Behavior of Reinforced Concrete Beams in Torsion." *Proceedings of the Institution of Civil Engineers* 75 (March 1983).
15. Alan H. Mattock. "How to Design for Torsion." In *Torsion of Structural Concrete*. Special Publication 18. American Concrete Institute, Detroit, MI, 1968.
16. T. C. Hsu and E. L. Kemp. "Background and Practical Application of Tentative Design Criteria for Torsion." *ACI Journal* 66 (January 1969).
17. D. Mitchell and M. P. Collins. "Detailing for Torsion." *ACI Journal* 73 (September 1976).
18. T. C. Hsu. *Unified Theory of Reinforced Concrete*. CRC Publication, Boca Raton, FL, 1993.
19. American Concrete Institute (ACI). "*Building Code Requirements for Structural Concrete*." ACI 318-14. ACI, Detroit, MI, 2014.
20. B. J. Wilson and J. F. Quereau. "A Simple Method of Determining Stress in Curved Flexural Members." Circular 16. University of Illinois Engineering Exp. Station, Urbana-Champaign, 1925.
21. S. Timoshenko. "Bending Stresses in Curved Tubes of Rectangular Cross Sections." *Trans. ASME* 45 (1923).
22. S. Timoshenko. *Strength of Materials*. Van Nostrand, New York, 1930.
23. R. J. Roark and W. C. Young. *Formulas for Stress and Strain*, 5th ed. McGraw-Hill, New York, 1975, pp. 209–285.

## PROBLEMS

For each problem, compute the cracking moment  $\phi T_{cr}$  and the maximum factored torque  $\phi T_n$  that can be applied without using torsional web reinforcement. Use  $f'_c = 4$  ksi and  $f_y = 60$  ksi.

- 15.1 A rectangular section with  $b = 16$  in. and  $h = 24$  in.
- 15.2 A rectangular section with  $b = 12$  in. and  $h = 20$  in.
- 15.3 A T-section with  $b = 48$  in.,  $b_w = 12$  in.,  $t = 4$  in., and  $h = 25$  in. Assume flanges are confined with closed stirrups.
- 15.4 A T-section with  $b = 60$  in.,  $b_w = 16$  in.,  $t = 4$  in., and  $h = 30$  in. Assume flanges are confined with closed stirrups.
- 15.5 An inverted L-section with  $b = 32$  in.,  $b_w = 14$  in.,  $t = 6$  in., and  $h = 24$  in. The flange does not have closed stirrups.
- 15.6 An inverted L-section with  $b = 40$  in.,  $b_w = 12$  in.,  $t = 6$  in., and  $h = 30$  in. The flange contains confined closed stirrups.
- 15.7 Determine the necessary web reinforcement for a simple beam subjected to an equilibrium factored torque  $T_u = 220$  K·in. and  $V_u = 36$  K. The beam section has  $b = 14$  in.,  $h = 22$  in., and  $d = 19.5$  in., and is reinforced on the tension side by four no. 9 bars. Use  $f'_c = 4$  ksi and  $f_y = 60$  ksi.
- 15.8 Repeat Problem 15.7 using  $f'_c = 5$  ksi and  $f_y = 60$  ksi.
- 15.9 The section of an edge (spandrel) beam is shown in Fig. 15.17. The critical section of the beam is subjected to an equilibrium torque  $T_u = 300$  K·in. and a shear  $V_u = 60$  K. Determine the necessary web reinforcement using  $f'_c = 4$  ksi and  $f_y = 60$  ksi. Consider that the flange is not reinforced with closed stirrups.
- 15.10 Repeat Problem 15.9. Considering that the flange is effective and contains closed stirrups.
- 15.11 The T-section shown in Fig. 15.18 is subjected to a factored shear  $V_u = 28$  K and a factored equilibrium torque  $T_u = 300$  K·in. and  $M_u = 250$  K·ft. Design the necessary flexural and web reinforcement. Use  $f'_c = 4$  ksi and  $f_y = 60$  ksi.
- 15.12 Repeat Problem 15.11 if  $V_u = 36$  K,  $T_u = 360$  K·in.,  $M_u = 400$  K·ft, and  $h = 24$  in.
- 15.13 Repeat Problem 15.11 using  $f'_c = 3$  ksi and  $f_y = 60$  ksi.

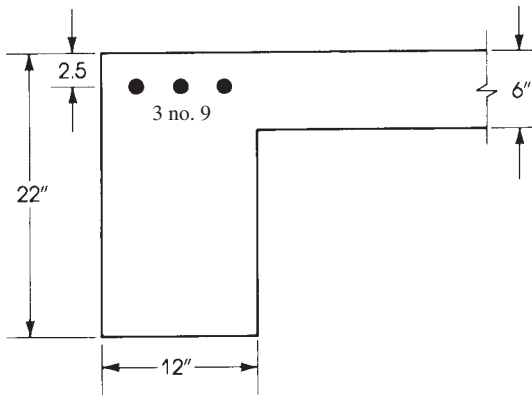


Figure 15.17 Problem 15.9.

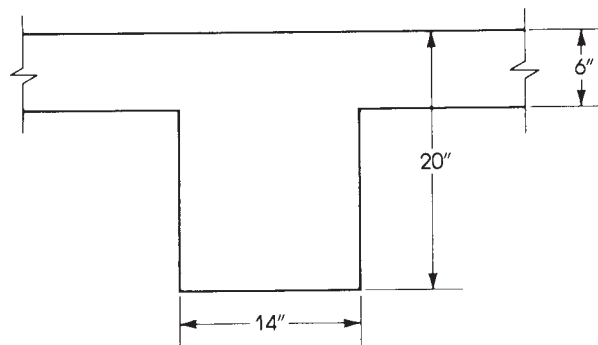


Figure 15.18 Problem 15.11.

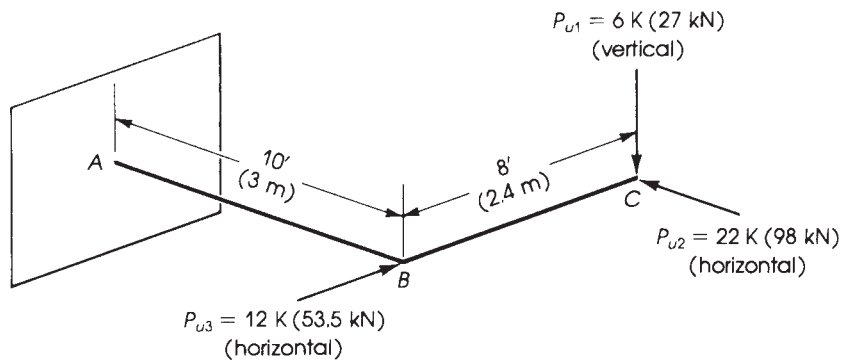
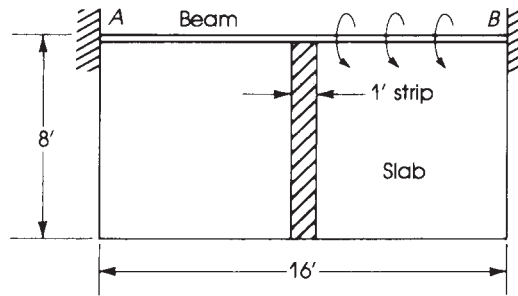


Figure 15.19 Problem 15.17.

- 15.14 Repeat Problem 15.11 if  $T_u$  is a compatibility torsion.
- 15.15 Repeat Problem 15.13 if  $T_u$  is a compatibility torsion.
- 15.16 Repeat Problem 15.7 if  $T_u$  is a compatibility torsion.
- 15.17 The cantilever beam shown in Fig. 15.19 is subjected to the factored load shown.
  - a. Draw the axial and shearing forces and the bending and torsional moment diagrams.



**Figure 15.20** Problem 15.18.

- b. Design the beam section at  $A$  using a steel percentage less than or equal to  $\rho_{\max}$  for bending moment. Use  $b = 16$  in. (300 mm),  $f'_c = 4$  ksi, and  $f_y = 60$  ksi.
- 15.18** The size of the slab shown in Fig. 15.20 is  $16 \times 8$  ft; it is supported by the beam  $AB$ , which is fixed at both ends. The uniform dead load on the slab (including its own weight) equals 100 psf, and the uniform live load equals 80 psf. Design the section at support  $A$  of beam  $AB$  using  $f'_c = 4$  ksi,  $f_y = 60$  ksi,  $b_w = 14$  in.,  $h = 24$  in., a slab thickness of 5 in., and the ACI Code requirements.

# CHAPTER 16

## CONTINUOUS BEAMS AND FRAMES



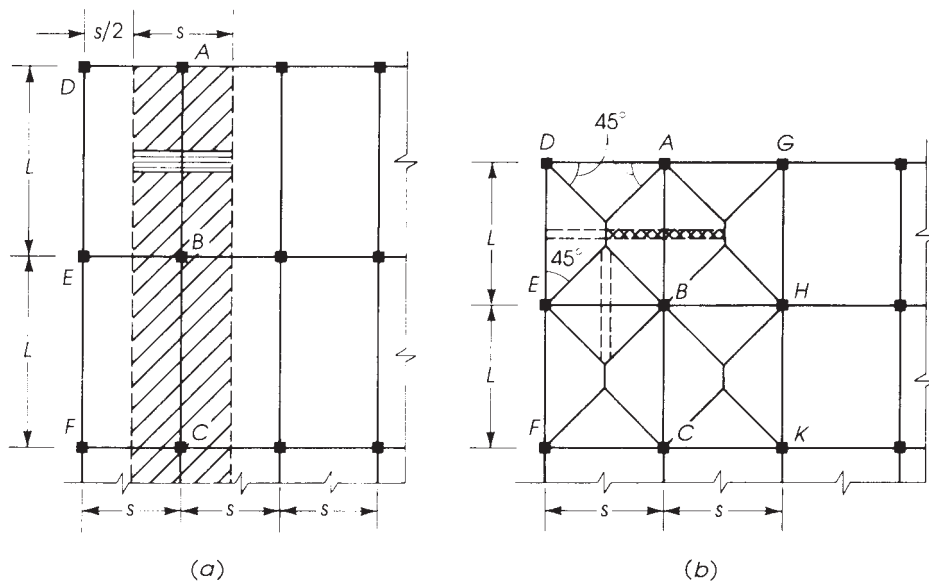
Reinforced concrete parking structure, Minneapolis, Minnesota.

### 16.1 INTRODUCTION

Reinforced concrete buildings consist of different types of structural members, such as slabs, beams, columns, and footings. These structural members may be cast in separate units as precast concrete slabs, beams, and columns or with the steel bars extending from one member to the other, forming a monolithic structure. Precast units are designed as structural members on simple supports unless some type of continuity is provided at their ends. In monolithic members, continuity in the different elements is provided, and the structural members are analyzed as statically indeterminate structures.

The analysis and design of continuous one-way slabs were discussed in Chapter 9, and the design coefficients and reinforcement details were shown in Figs. 9.8 and 9.9. In one-way floor systems, the loads from slabs are transferred to the supporting beams, as shown in Fig. 16.1*a*. If the factored load on the slab is  $w_u$  psf, the uniform load on beams  $AB$  and  $BC$  per unit length is  $w_u s$  plus the self-weight of the beam. The uniform load on beams  $DE$  and  $EF$  is  $w_u s/2$  plus the self-weight of the beam. The load on column  $B$  equals  $W_u LS$ , whereas the loads on columns  $E$ ,  $A$ , and  $D$  are  $W_u LS/2$ ,  $W_u SL/2$ , and  $W_u LS/4$ , respectively.

In two-way rectangular slabs supported by adequate beams on four sides, the floor loads are transferred to the beam from tributary areas bounded by  $45^\circ$  lines, as shown in Fig. 16.1*b*. Part of the floor loads are transferred to the long beams  $AB$ ,  $BC$ ,  $DE$ , and  $EF$  from trapezoidal areas, whereas the rest of the floor loads are transferred to the short beams  $AD$ ,  $BE$ , and  $CF$  from triangular areas. In square slabs, loads are transferred to all surrounding beams from triangular floor areas. Interior beams carry loads from both sides, whereas end beams carry loads from one side only. Beams in both directions are usually cast monolithically with the slabs; therefore, they should be analyzed as statically indeterminate continuous beams. The beams transfer their loads in turn to the supporting columns. The load on column  $B$  equals  $W_u LS$ , while the loads on columns  $E$ ,  $A$ , and  $D$  are  $W_u LS/2$ ,  $W_u SL/2$ , and  $W_u LS/4$ , respectively. The tributary area for each column extends from the centerlines of adjacent spans in each direction.



**Figure 16.1** Slab loads on supporting beams: (a) one-way direction,  $L/s > 2$ , and (b) two-way direction,  $L/s \leq 2$ .

## 16.2 MAXIMUM MOMENTS IN CONTINUOUS BEAMS

### 16.2.1 Basic Analysis

The computation of bending moments and shear forces in reinforced concrete continuous beams is generally based on the elastic theory. When reinforced concrete sections are designed using the strength design method, the results are not entirely consistent with the elastic analysis. However, the ACI Code does not include provisions for a plastic design or limit design of reinforced concrete continuous structures except in allowing moment redistribution, as is explained later in this chapter.

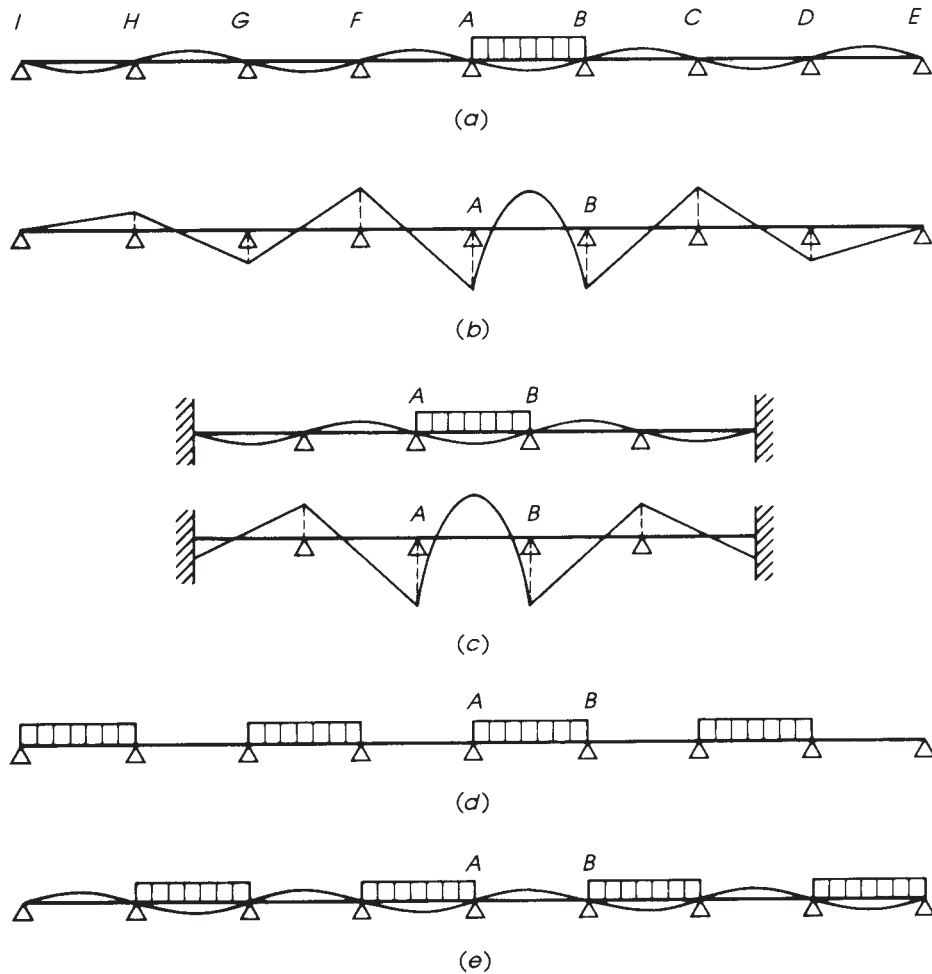
### 16.2.2 Loading Application

The bending moment at any point in a continuous beam depends not only on the position of loads on the same span but also on the loads on the other spans. In the case of dead loads, all spans must be loaded simultaneously because the dead load is fixed in position and magnitude. In the case of moving loads or occasional live loads, the pattern of loading must be considered to determine the maximum moments at the critical sections. Influence lines may be used to determine the position of the live load to calculate the maximum and minimum moments. However, in this chapter, simple rules based on load–deflection curves are used to determine the loading pattern that produces maximum moments.

### 16.2.3 Maximum and Minimum Positive Moments within a Span

The maximum positive bending moment in a simply supported beam subjected to a uniform load  $w$  K/ft is at midspan, and  $M = wl_2^2/8$ . If one or both ends are continuous, the restraint at the continuous end will produce a negative moment at the support and slightly shift the location of

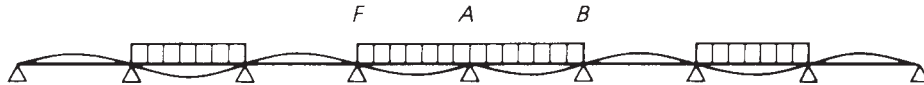




**Figure 16.2** Loadings for maximum and minimum moment within span AB.

the maximum positive moment from midspan. The deflected shape of the continuous beam for a single-span loading is shown in Fig. 16.2a; downward deflection indicates a positive moment and upward deflection indicates a negative moment. If all spans deflected downward are loaded, each load will increase the positive moment at the considered span AB (Fig. 16.2d). Therefore, to calculate the maximum positive moment within a span, the live load is placed on that span and on every alternate span on both sides. The factored live-load moment, calculated as explained before, must be added to the factored dead-load moment at the same section to obtain the maximum positive moment.

The bending moment diagram due to a uniform load on AB is shown in Fig. 16.2b. The deflections and the bending moments decrease rapidly with the distance from the loaded span AB. Therefore, to simplify the analysis of continuous beams, the moments in any span can be computed by considering the loaded span and two spans on either side of the considered span AB, assuming fixed supports at the far ends (Fig. 16.2c).



**Figure 16.3** Loading for maximum negative moment at support A.

If the spans adjacent to span  $AB$  are loaded, the deflection curve will be as shown in Fig. 16.2*e*. The deflection within span  $AB$  will be upward, and a negative moment will be produced in span  $AB$ . This negative moment must be added to the positive moment due to dead load to obtain the final bending moment. Therefore, to calculate the minimum positive moment (or maximum negative moment) within a span  $AB$ , the live load is placed on the adjacent spans and on every alternate span on both sides of  $AB$  (Fig. 16.2*e*).

#### 16.2.4 Maximum Negative Moments at Supports

In this case, it is required to determine the maximum negative moment at any support, say, support  $A$  (Fig. 16.3). When span  $AB$  is loaded, a negative moment is produced at support  $A$ . Similarly, the loading of span  $AF$  will produce a negative moment at  $A$ . Therefore, to calculate the maximum negative moment at any support, the live load is placed on the two adjacent spans and on every alternate span on both sides (Fig. 16.3).

In the structural analysis of continuous beams, the span length is taken from center to center of the supports, which are treated as knife-edge supports. In practice, the supports are always made wide enough to take the loads transmitted by the beam, usually the moments acting at the face of supports. To calculate the design moment at the face of the support, it is quite reasonable to deduct a moment equal to  $V_u c/3$  from the factored moment at the centerline of the support, where  $V_u$  is the factored shear and  $c$  is the column width.

#### 16.2.5 Moments in Continuous Beams

Continuous beams and frames can be analyzed using approximate methods or computer programs, which are available commercially. Other methods, such as the displacement and force methods of analysis based on the calculation of the stiffness and flexibility matrices, may also be adopted. Slope deflection and moment–distribution methods may also be used. These methods are explained in books dealing with the structural analysis of beams and frames. However, the ACI Code, Section 6.5, gives approximate coefficients for calculating the bending moments and shear forces in continuous beams and slabs. These coefficients were given in Chapter 9. The moments obtained using the ACI coefficients will be somewhat larger than those arrived at by exact analysis. The limitations stated in the use of these coefficients must be met.

#### Example 16.1

The slab–beam floor system shown in Fig. 16.4 carries a uniform live load of 130 psf and a dead load that consists of the slab's own weight plus 80 psf. Using the ACI moment coefficients, design a typical interior continuous beam and draw detailed sections. Use  $f'_c = 4$  ksi,  $f_y = 60$  ksi, beam width ( $b$ ) = 12 in.,  $12 \times 12$  in. columns, and a slab thickness of 5.0 in.

#### Solution

1. Design of slabs: The floor slabs act as one-way slabs because the ratio of the long to the short side is greater than 2. The design of a typical continuous slab was discussed in Example 9.4.

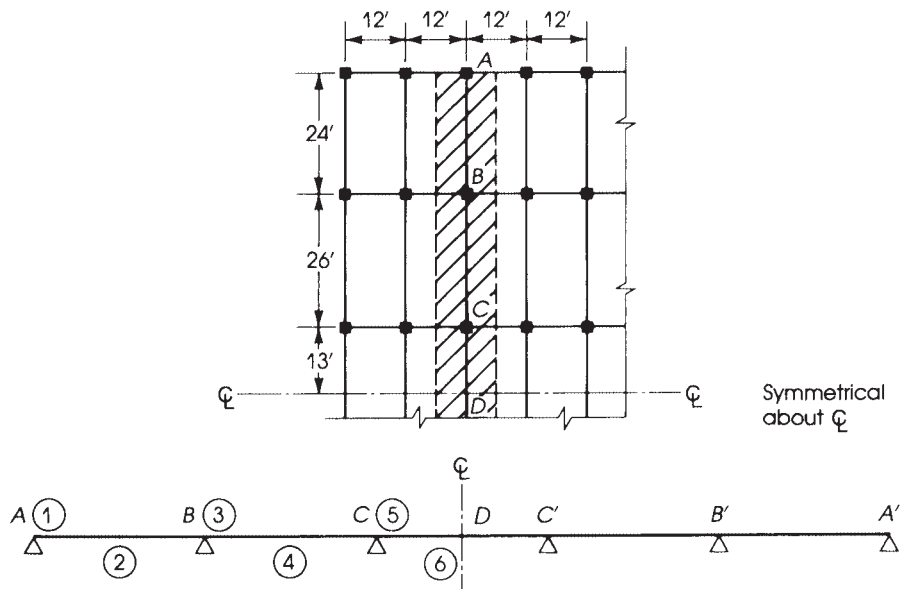


Figure 16.4 Example 16.1.

2. Loads on slabs:

$$\text{Dead load} = \frac{5}{12} \times 150 + 80 = 142.5 \text{ psf}$$

$$\text{Live load} = 130 \text{ psf}$$

$$\text{Factored load } (w_u) = 1.2(142.5) + 1.6(130) = 379 \text{ psf}$$

Loads on beams: A typical interior beam  $ABCD$  carries slab loads from both sides of the beam, with a total slab width of 12 ft.

$$\text{Factored load on beam} = 12 \times 379 + 1.2 \times (\text{self-weight of beam web})$$

The depth of the beam can be estimated using the coefficients of minimum thickness of beams shown in Table 1. For  $f_y = 60$  ksi, the minimum thickness of the first beam  $AB$  is  $L/18.5 = (24 \times 12)/18.5 = 15.6$  in. Assume a total depth of 22 in. and a web depth of  $22 - 5 = 17$  in. Therefore, the factored load on beam  $ABCD$  is

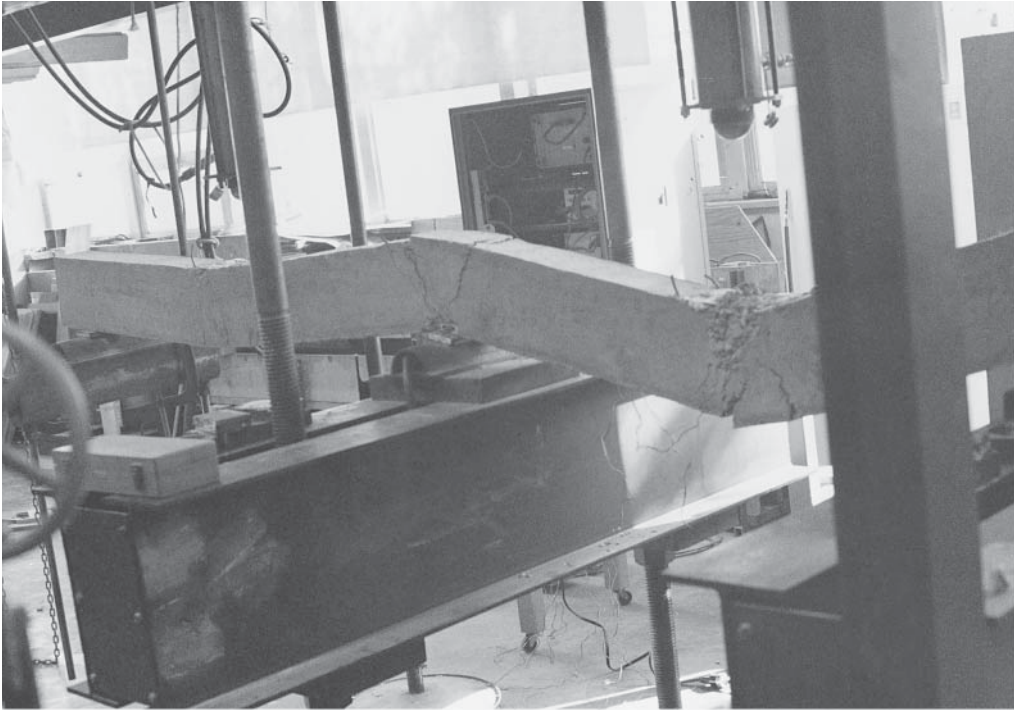
$$w_u = 12 \times 379 + 1.2 \left( \frac{17 \times 12}{144} \times 150 \right) = 4804 \text{ lb/ft}$$

Use 4.8 K/ft.

3. Moments in beam  $ABC$ : Moment coefficients are shown in Fig. 9.8. The beam is continuous on five spans and symmetrical about the centerline at  $D$ . Therefore, it is sufficient to design half of the beam  $ABCD$  because the other half will have similar dimensions and reinforcement. Because the spans  $AB$  and  $BC$  are not equal and the ratio  $\frac{26}{24}$  is less than 1.2, the ACI moment coefficients can be applied to this beam. Moreover, the average of the adjacent clear span is used to calculate the negative moments at the supports.

Moments at critical sections are calculated as follows (Fig. 16.4):

$$M_u = \text{coefficient} \times w_u l_n^2$$



Test on a continuous reinforced concrete beam. Plastic hinges developed in the positive and negative maximum moment regions.

Location	1	2	3	4	5	6
Moment coefficient	$-\frac{1}{16}$	$+\frac{1}{14}$	$-\frac{1}{10}$	$+\frac{1}{16}$	$-\frac{1}{11}$	$+\frac{1}{16}$
$M_u$ (K · ft)	-158.7	181.4	-276.5	187.5	-272.7	187.5

4. Determine beam dimensions and reinforcement.

- a. Maximum negative moment is  $-276.5$  K ft. Using  $\rho_{\max} = 0.016$ ,  $R_u = 740$  psi

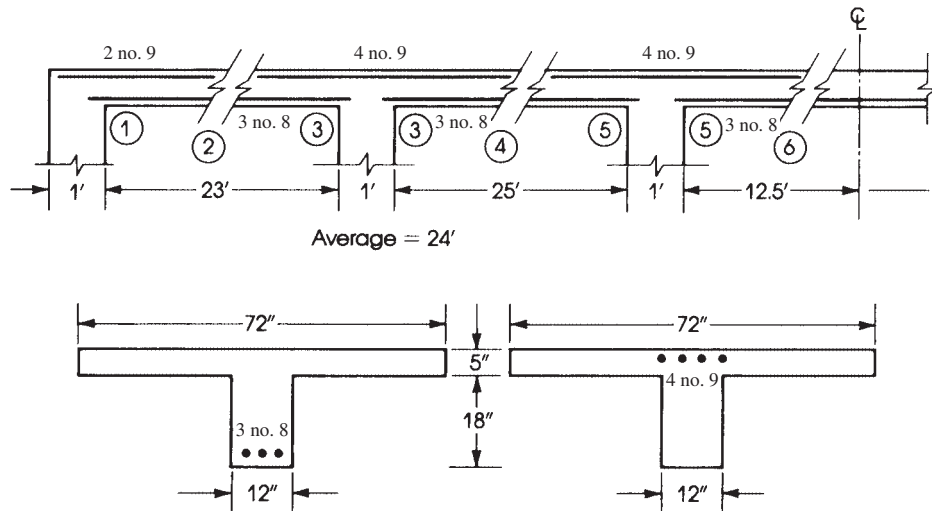
$$R_{u,\max} = 820 \text{ psi} \quad \rho_{\max} = 0.01806 \text{ (Table 4.1)} \quad \phi = 0.9$$

$$d = \sqrt{\frac{M_u}{R_u b}} = \sqrt{\frac{276.5 \times 12}{0.74 \times 12}} = 19.3 \text{ in.}$$

For one row of reinforcement, total depth is  $19.3 + 2.5 = 21.8$  in., say, 23 in., and actual  $d$  is 20.5 in.  $A_s = 0.016 \times 12 \times 19.3 = 3.7 \text{ in.}^2$ ; use four no. 9 bars in one row. Note that the total depth used here is 23 in., which is more than the 22 in. assumed to calculate the weight of the beam. The additional load is negligible, and there is no need to revise the calculations.

- b. The sections at the supports act as rectangular sections with tension reinforcement placed within the flange. The reinforcements required at the supports are as follows:  
 c. For the midspan T-sections,  $M_u = +187.5$  K · ft. For  $a = 1.0$  in. and flange width = 72 in.,

$$A_s = \frac{M_u}{\phi f_y (d - a/2)} = \frac{187.5 \times 12}{0.9 \times 60 (20.5 - 1/2)} = 2.1 \text{ in.}^2$$



**Figure 16.5** Example 16.1: Reinforcement details.

$$\text{Check } a : \quad a = \frac{A_s f_y}{0.85 f'_c b} = \frac{2.1 \times 60}{0.85 \times 3 \times 72} = 0.7 \text{ in.}$$

Revised  $a$  gives  $A_s = 2.07 \text{ in.}^2$ . Therefore, use three no. 8 bars ( $A_s = 2.35 \text{ in.}^2$ ) for all midspan sections. Reinforcement details are shown in Fig. 16.5.

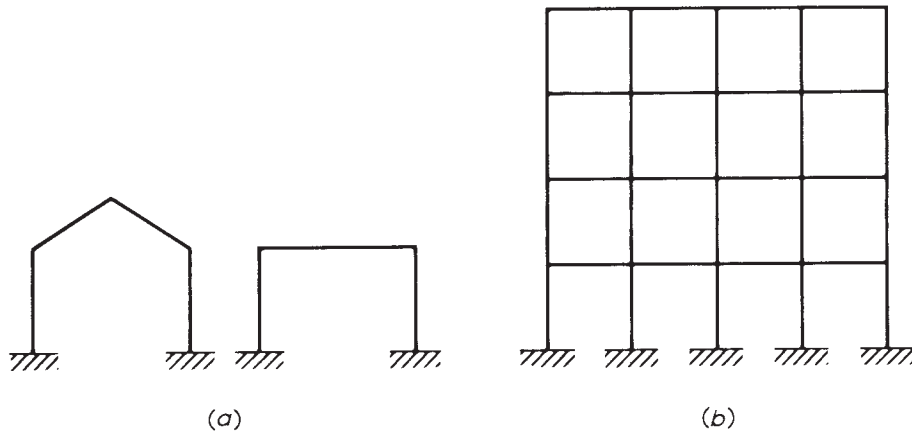
5. Design the beam for shear, as explained in Chapter 8.
6. Check deflection and cracking, as explained in Chapter 6.

## 16.3 BUILDING FRAMES

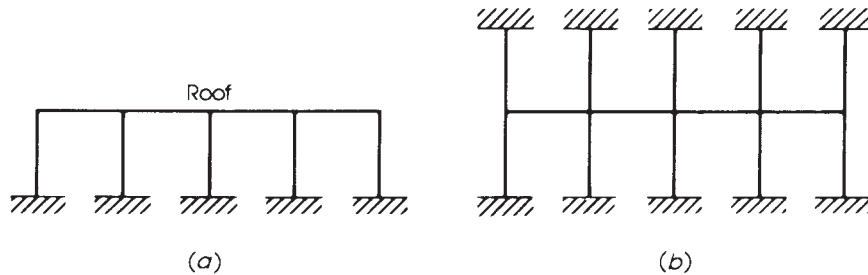
A building frame is a three-dimensional structural system consisting of straight members that are built monolithically and have rigid joints. The frame may be one bay long and one story high, such as the portal frames and gable frames shown in Fig. 16.6a, or it may consist of multiple bays and stories, as shown in Fig. 16.6b. All members of the frame are considered continuous in the three directions, and the columns participate with the beams in resisting external loads. Besides reducing moments due to continuity, a building frame tends to distribute the loads more uniformly on the frame. The effects of lateral loads, such as wind and earthquakes, are also spread over the whole frame, increasing its safety. For design purposes, approximate methods may be used by assuming a two-dimensional frame system.

A frame subjected to a system of loads may be analyzed by the equivalent frame method. In this method, the analysis of the floor under consideration is made assuming that the far ends of the columns above and below the slab level are fixed (Fig. 16.7). Usually, the analysis is performed using the moment–distribution method.

In practice, the size of panels, distance between columns, number of stories, and the height of each story are known because they are based upon architectural design and utility considerations. The sizes of beams and columns are estimated first, and their relative stiffnesses based on the gross



**Figure 16.6** (a) Gable and portal frames (schematic) and (b) multibay, multistory frame.



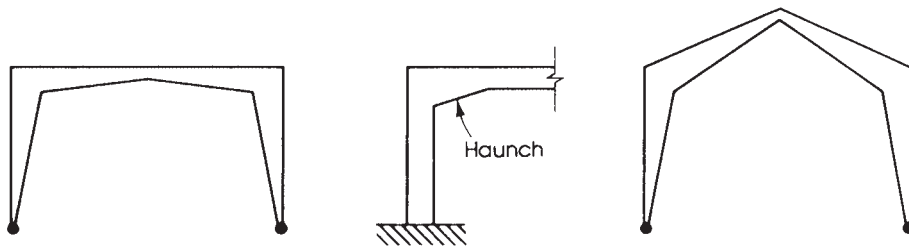
**Figure 16.7** Assumption of fixed column ends for frame analysis.

concrete sections are used. Once the moments are calculated, the sections assumed previously are checked and adjusted as necessary. More accurate analysis can be performed using computers, which is recommended in the structural analysis of statically indeterminate structures with several redundants. Methods of analysis are described in many books on structural analysis.

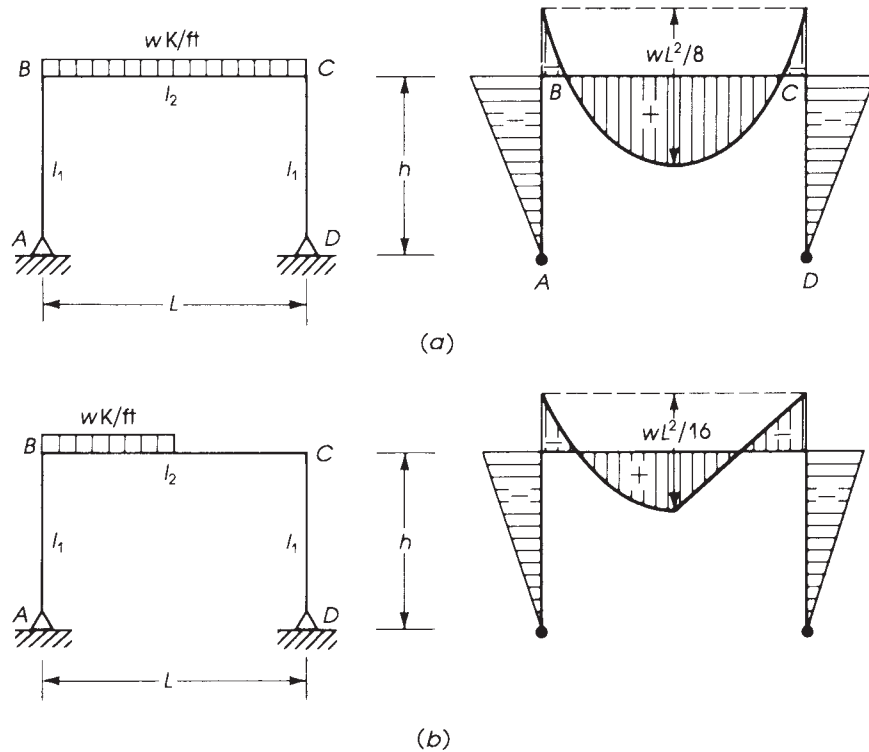
## 16.4 PORTAL FRAMES

A portal frame consists of a reinforced concrete stiff girder poured monolithically with its supporting columns. The joints between the girder and the columns are considered rigidly fixed, with the sum of moments at the joint equal to 0. Portal frames are used in building large-span halls, sheds, bridges, and viaducts. The top member of the frame may be horizontal (portal frame) or inclined (gable frame) (Fig. 16.8). The frames may be fixed or hinged at the base.

A statically indeterminate portal frame may be analyzed by the moment–distribution method or any other method used to analyze statically indeterminate structures. The frame members are designed for moments, shear, and axial forces, whereas the footings are designed to carry the forces acting at the column base.



**Figure 16.8** Portal and gable frames.



**Figure 16.9** Portal frame with two hinged ends. Bending moments are drawn on the tension side.

Girders and columns of frames may be of uniform or variable depths, as shown in Fig. 16.8. The forces in a single-bay portal frame of uniform sections may be calculated as follows.

#### 16.4.1 Two Hinged Ends

The forces in the members of a portal frame with two hinged ends [2] can be calculated using the following expressions (Fig. 16.9).

For the case of a uniform load on top member  $BC$ , let

$$K = 3 + 2 \left( \frac{I_2}{I_1} \times \frac{h}{L} \right)$$

where

$I_1, I_2$  = column and beam moments of inertia  
 $h, L$  = height and span of frame

The bending moments at joints  $B$  and  $C$  are

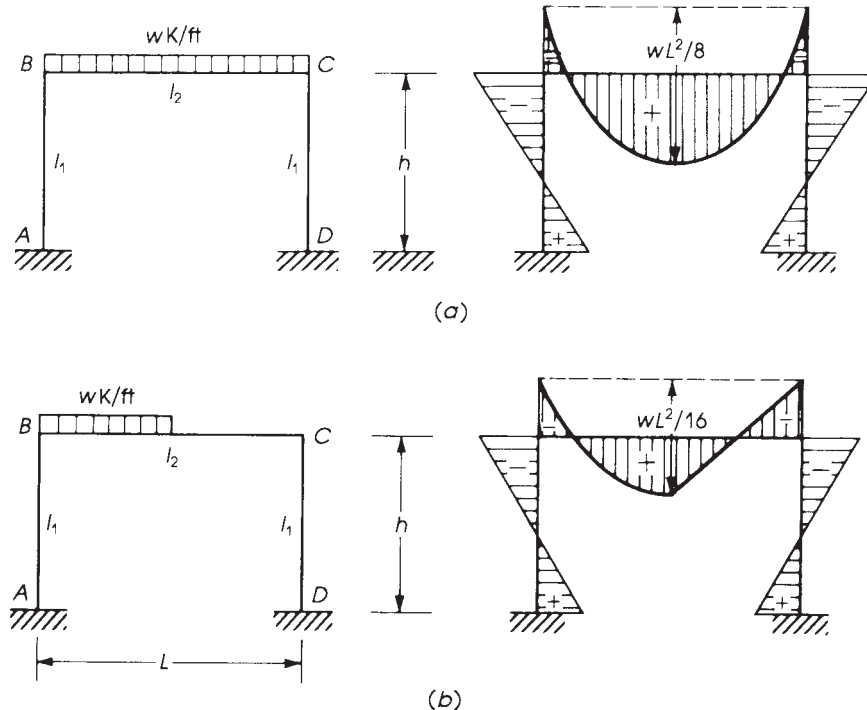
$$M_B = M_C = -\frac{wL^2}{4K}$$

Maximum positive moment at midspan is given as  $BC = \frac{wL^2}{8} + M_B$

The horizontal reaction at  $A$  is  $H_A = M_B/h = H_D$ . The vertical reaction at  $A$  is  $V_A = WL/2 = V_D$ . For a uniform load on half the beam  $BC$ , Fig. 16.9b:  $M_B = M_C = -WL^2/8K$ ,  $H_A = H_D = M_B/h$ ,  $V_A = 3WL/8$ , and  $V_D = WL/8$ .

### 16.4.2 Two Fixed Ends

The forces in the members of a portal frame with two fixed ends [2] can be calculated as follows (Fig. 16.10).



**Figure 16.10** Portal frame with fixed ends. Bending moments are drawn on the tension side.



For a uniform load on top member  $BC$ , let

$$K_1 = 2 + \left( \frac{I_2}{I_1} \times \frac{h}{L} \right)$$

$$M_B = M_C = -\frac{wL^2}{6K_1}$$

$$M_A = M_D = \frac{M_B}{2} \quad M(\text{midspan}) = \frac{wL^2}{8} + M_B$$

$$H_A = H_D = \frac{3M_A}{h} \quad \text{and} \quad V_A = V_D = \frac{wL}{2}$$

For a uniform load on half the top member  $BC$ , let

$$K_2 = 1 + 6 \left( \frac{I_2}{I_1} \times \frac{h}{L} \right)$$

Then

$$M_A = \frac{wL^2}{8} \left( \frac{1}{3K_1} - \frac{1}{8K_2} \right) \quad M_B = \frac{wl^2}{8} \left( \frac{2}{3K_1} + \frac{1}{8K_2} \right)$$

$$M_C = \frac{wL^2}{8} \left( \frac{2}{3K_1} - \frac{1}{8K_2} \right) \quad M_D = \frac{wL^2}{8} \left( \frac{1}{3K_1} - \frac{1}{8K_2} \right)$$

$$H_A = H_D = \frac{wl^2}{8} \times \frac{1}{K_1 h}$$

$$V_A = \frac{wL}{2} - V_D \quad \text{and} \quad V_D = \frac{wL}{8} \left( 1 - \frac{1}{4K_2} \right)$$

## 16.5 GENERAL FRAMES

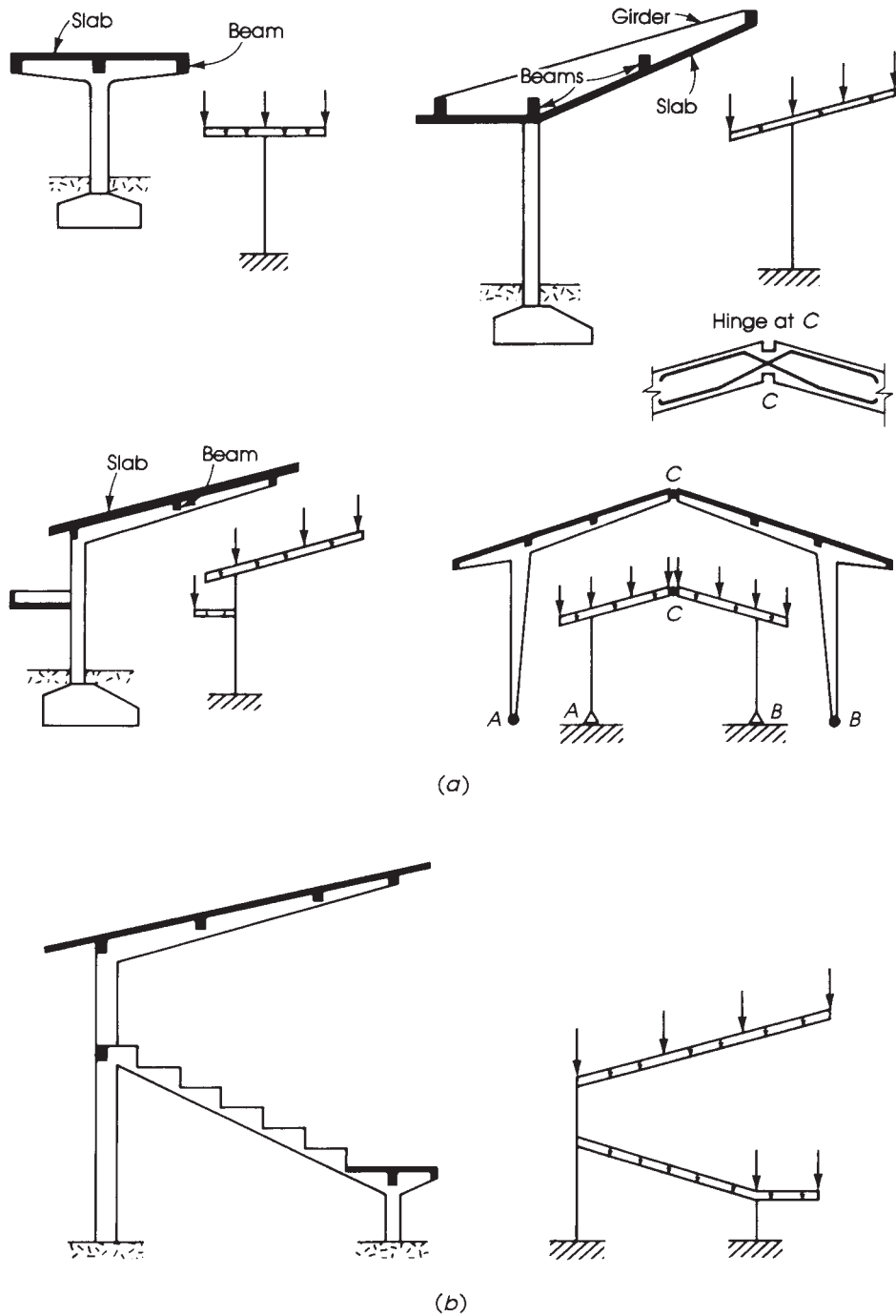
The main feature of a frame is its rigid joints, which connect the horizontal or inclined girders of the roof to the supporting structural members. The continuity between the members tends to distribute the bending moments inherent in any loading system to the different structural elements according to their relative stiffnesses. Frames may be classified as

1. Statically determinate frames (Fig. 16.11*a*).
2. Statically indeterminate frames (Fig. 16.12).
3. Statically indeterminate frames with ties (Fig. 16.13).

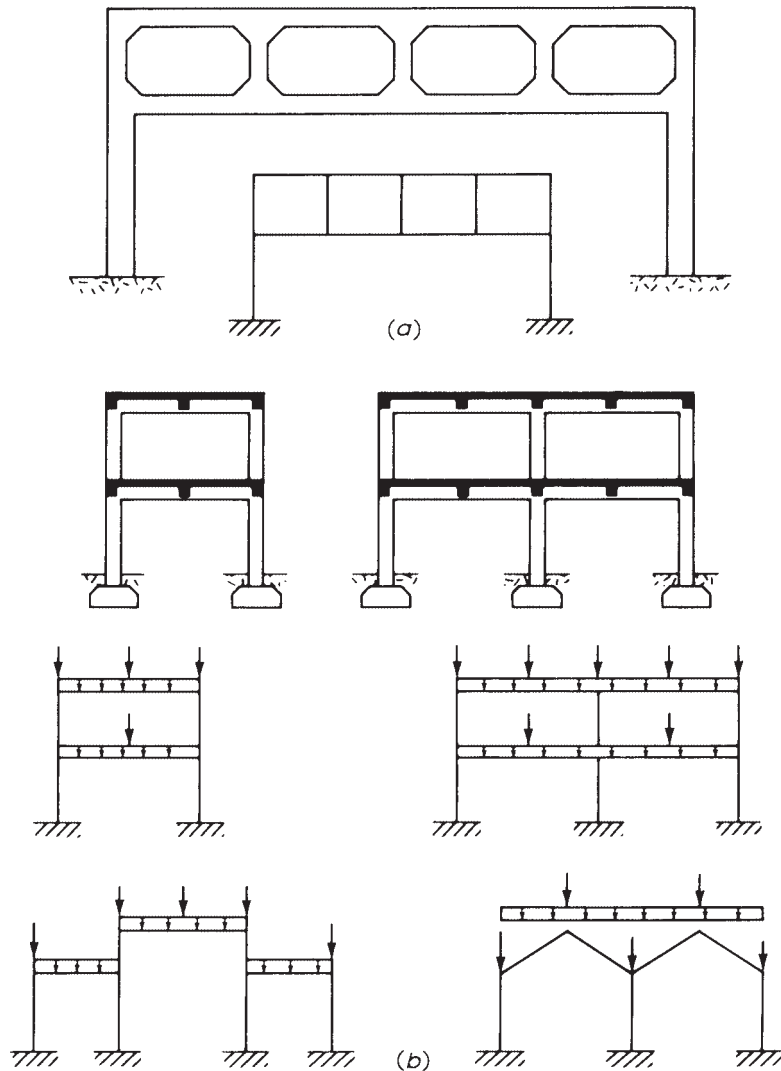
Different methods for the analysis of frames and other statically indeterminate structures are described in books dealing with structural analysis. Once the bending moments, shear, and axial forces are determined, the sections can be designed as the examples in this book are. Analysis may also be performed using computer programs.

## 16.6 DESIGN OF FRAME HINGES

The main types of hinges used in concrete structures are Mesnager hinges, Considère hinges, and lead hinges [19]. The description of each type is given next.



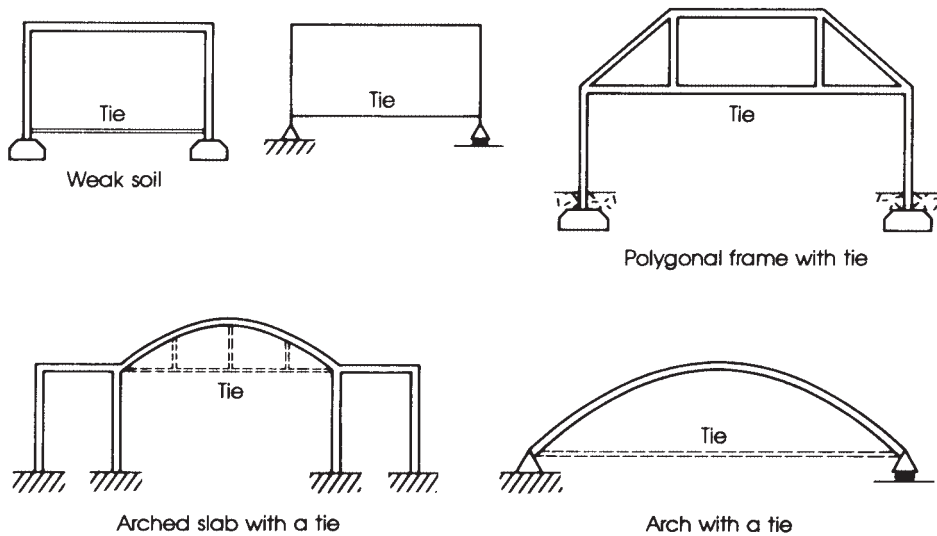
**Figure 16.11** (a) Statically determinate frames and (b) reinforced concrete stadium.



**Figure 16.12** (a) Vierendeel girder and (b) statically indeterminate frames.

### 16.6.1 Mesnager Hinge

The forces that usually act on a hinge are a horizontal force,  $H$ , and a vertical force,  $P$ . The resultant of the two forces,  $R$ , is transferred to the footing through the crossing bars  $A$  and  $B$  shown in Fig. 16.14. The inclination of bars  $A$  and  $B$  to the horizontal varies between  $30^\circ$  and  $60^\circ$ , with a minimum distance  $a$ , measured from the lower end of the frame column, equal to  $8D$ , where  $D$  is the diameter of the inclined bars. The gap between the frame column and the top of the footing  $y$  varies between 1 in. and  $1.3h'$ , where  $h'$  is the width of the concrete section at the hinge level. A practical gap height ranges between 2 and 4 in. The rotation of the frame ends is taken by the hinges, and the gap is usually filled with bituminous cork or similar flexible material. The bitumen protects the cork in contact with the soil from deterioration. The crossing bars  $A$  and  $B$  are subjected



**Figure 16.13** Structures with ties.

to compressive stresses that must not exceed one-third the yield strength of the steel bars  $f_y$  under service loads or  $0.55f_y$  under factored loads. The low stress is assumed because any rotation at the hinge tends to bend the bars and induces secondary flexural stresses. It is generally satisfactory to keep the compression stresses low rather than to compute secondary stresses. The areas of bars  $A$  and  $B$  are calculated as follows:

$$\text{Area of bars } A: \quad A_{s_1} = \frac{R_1}{0.55f_y} \quad (16.1)$$

$$\text{Area of bars } B: \quad A_{s_2} = \frac{R_2}{0.55f_y} \quad (16.2)$$

where  $R_1$  and  $R_2$  are the components of the resultant  $R$  in the direction of the inclined bars  $A$  and  $B$  using factored loads. The components  $R_1$  and  $R_2$  are usually obtained by statics as follows:

$$H + R_2 \sin \theta = R_1 \sin \theta \quad \text{and} \quad R_2 = R_1 - \frac{H}{\sin \theta} \quad (16.3a)$$

Also,  $(R_1 + R_2) \cos \theta = P_u$ , so

$$\begin{aligned} R_1 &= \frac{P_u}{\cos \theta} - R_2 = \frac{P_u}{\cos \theta} - \left[ R_1 - \frac{H}{\sin \theta} \right] \\ R_1 &= \frac{1}{2} \left[ \frac{P_u}{\cos \theta} + \frac{H}{\sin \theta} \right] \end{aligned} \quad (16.3b)$$

The inclined hinge bars transmit their force through the bond along the embedded lengths in the frame columns and footings. Consequently, the bars exert a bursting force, which must be resisted by ties. The ties should extend a distance  $a = 8D$  (the larger bar diameter of bars  $A$  and  $B$ ) in both columns and footings. The bursting force  $F$  can be estimated as

$$F = \frac{P_u}{2} \tan \theta + \frac{Ha}{0.85d} \quad (16.4)$$

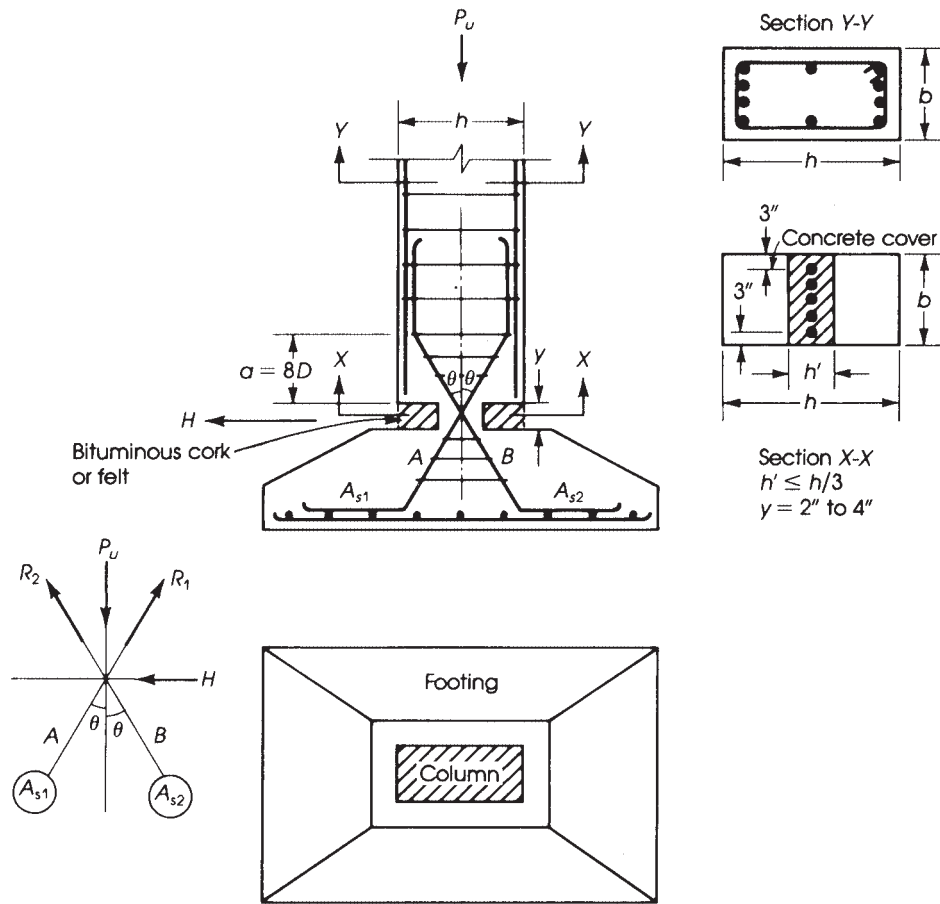


Figure 16.14 Hinge details.

If the contribution of concrete is neglected, then the area of tie reinforcement,  $A_{st}$ , required to resist  $F$  is

$$A_{st} = \frac{F}{\phi f_y} = \frac{F}{0.85 f_y} \quad (16.5)$$

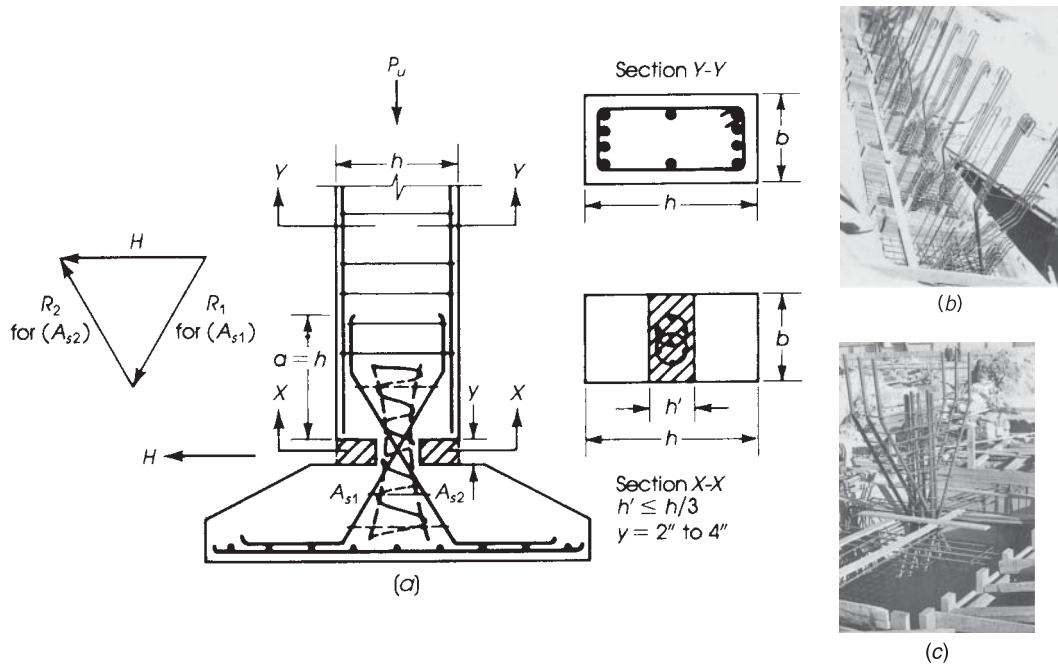
The stress in the ties can also be computed as follows:

$$f_s(\text{ties}) = \frac{(P_u/2)\tan\theta + Ha/(0.85d)}{0.005ab + A_{st}(\text{ties})} \leq 0.85f_y \quad (16.6)$$

where

- $A_{st}$  = area of ties within distance  $a = 8D$
- $d$  = effective depth of column section
- $b$  = width of column section

This type of hinge is used for moderate forces and limited by the maximum number of inclined bars that can be placed within the column width.



**Figure 16.15** (a) Considère hinge, (b) Mesnager hinges for a series of portal frames, and (c) Considère hinge.

### 16.6.2 Considère Hinge

The difference between the *Considère hinge* and the *Mesnager* one is that the normal force  $P_u$  is assumed to be transmitted to the footing by one or more short, spirally reinforced columns extending deep into the footing, whereas the horizontal force  $H$  is assumed to be resisted by the inclined bars  $A$  and  $B$  (Fig. 16.15). The load capacity of the spirally reinforced short column may be calculated using Eq. 10.7, neglecting the factor 0.85 for minimum eccentricity:

$$P_u = \phi P_n = 0.75[0.85f'_c(A_g - A_{st}) + A_{st}f_y] \quad (16.7)$$

where  $A_g$  is the area of concrete hinge section, or  $bh'$ , and  $A_{st}$  is the area of longitudinal bars within the spirals. Ties should be provided in the column up to a distance equal to the long side of the column section  $h$ .

### 16.6.3 Lead Hinges

*Lead hinges* are sometimes used in reinforced concrete frames. In this type of hinge, a lead plate, usually 0.75 to 1.0 in. thick, is used to transmit the normal force,  $P_u$ , to the footing. The horizontal force  $H$  is resisted by vertical bars placed at the center of the column and extended to the footing (Fig. 16.16). At the base of the column, the axial load  $P_u$  should not exceed the bearing strength specified by the ACI Code, Section 22.8.3, of  $\phi(0.85f'_cA_1)$ , where  $\phi = 0.65$  and  $A_1 = bh'$ . The area of the vertical bars is  $A_{s_v} = H/0.6f_y$ , where  $H =$  factored horizontal force.

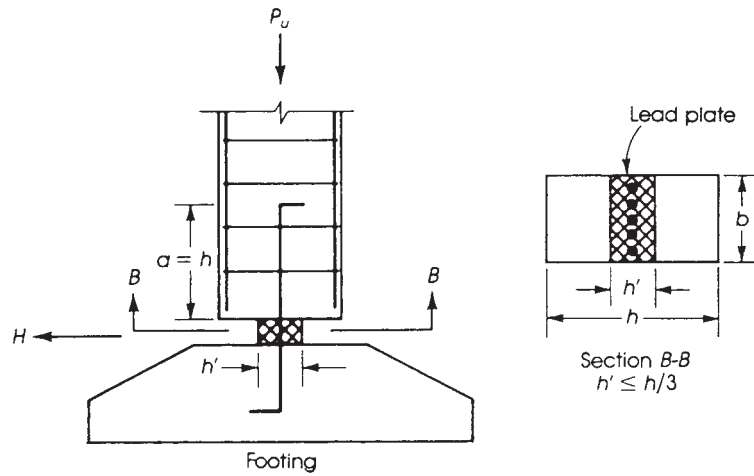


Figure 16.16 Lead hinge.

**Example 16.2**

An  $84 \times 40$ -ft hall is to be covered by reinforced concrete slabs supported on hinged-end portal frames spaced at 12 ft on centers (Fig. 16.17). The frame height is 15 ft, and no columns are allowed within the hall area. The dead load on the slabs is that due to self-weight plus 75 psf from roof finish. The live load on the slab is 85 psf. Design a typical interior frame using normal-weight concrete with  $f'_c = 4$  ksi and  $f_y = 60$  ksi for the frame and a column width of  $b = 16$  in.

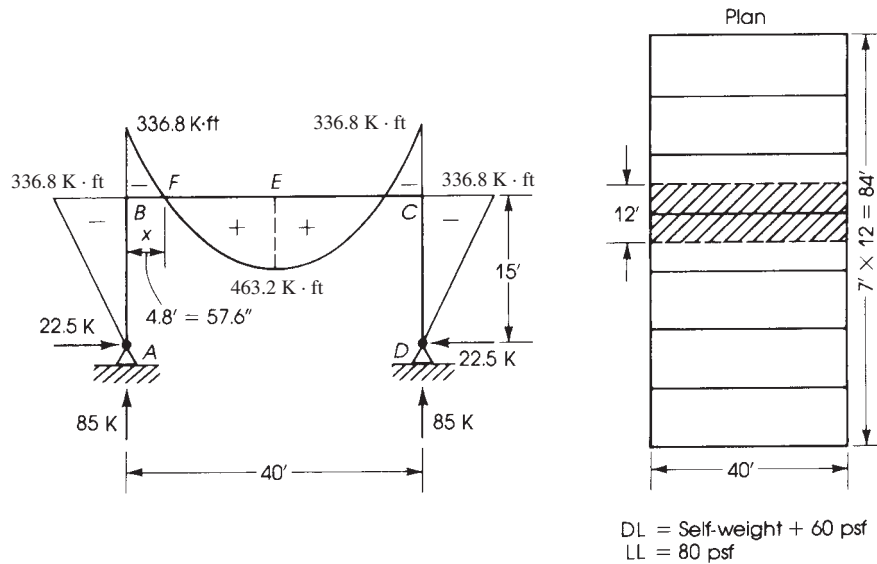


Figure 16.17 Example 16.2: Design of portal frame.

**Solution**

The main structural design of the building will consist of the following:

- Design of one-way slabs
- Analysis of the portal frame
- Design of the frame girder due to moment
- Design of the frame girder due to shear
- Design of columns
- Design of hinges

Design of footings

1. One-way roof slab: The minimum thickness of the first slab is  $L/30$  because one end is continuous and the other end is discontinuous (Table A.6 in Appendix A):

$$\text{Minimum depth} = \frac{12 \times 12}{30} = 4.8 \text{ in.}$$

Assume a slab thickness of 5.0 in. and design the slab following the steps of Example 9.5.

2. Analysis of an interior portal frame:

- a. The loads on slabs are

$$\text{Dead load on slabs} = 75 + \left( \frac{5}{12} \times 150 \right) = 137.5 \text{ psf}$$

$$\text{Factored load on slabs} = 1.2 \times 137.5 + 1.6 \times 85 = 301 \text{ psf}$$

- b. Determine loads on frames: The interior frame carries a load from a 12-ft slab in addition to its own weight. Assume that the depth of the beam is  $L/24 = (40 \times 12)/24 = 20$  in. Use a projection below the slab of 16 in., giving a total beam depth of 21 in.

$$\text{Dead load from self - weight of beam} = \left( \frac{16}{12} \right)^2 \times 150 = 267 \text{ lb/ft}$$

$$\text{Total factored load on frame} = 301 \times 12 + 1.2 \times 267$$

$$= 3932 \text{ lb/ft}$$

$$w_u = 4.0 \text{ K/ft}$$

- c. Determine the moment of inertia of the beam and columns sections. The beam acts as a T-section. The effective width of the slab acting with the beam is the smallest of span/4 =  $40 \times 12/4 = 120$  in.,  $16h_s + b_w = 16 \times 5 + 16 = 96$ , or  $12 \text{ ft} \times 12 = 144$  in. Use  $b = 96$  in. The centroid of the section from the top fibers is

$$y = \frac{96 \times 5 \times 2.5 + 16 \times 16 \times 13}{96 \times 5 + 16 \times 16} = 6.2 \text{ in.}$$

$$I_b(\text{beam}) = \left[ \frac{96}{12}(5)^3 + 96 \times 5(3.7)^2 \right] + \left[ \frac{16}{12}(16)^3 + 16 \times 16(6.8)^2 \right]$$

$$= 24,870 \text{ in.}^4$$

It is common practice to consider an approximate moment of inertia of a T-beam as equal to twice the moment of inertia of a rectangular section having the total depth of the web and slab:

$$I_b(\text{beam}) = 2 \times \frac{16}{12}(21)^3 = 24,696 \text{ in.}^4$$

(For an edge beam, approximate  $I = 1.5 \times bh^3/12$ .) Assume a column section  $16 \times 20$  in. (having the same width as the beam).

$$I_c(\text{column}) = \frac{16}{12}(20)^3 = 10,667 \text{ in.}^4$$



d. Let the factor

$$K = 3 + 2 \left( \frac{I_b}{L} \times \frac{h}{I_c} \right) = 3 + 2 \left( \frac{24,870}{40} \times \frac{15}{10,667} \right) = 4.75$$

Referring to Fig. 16.17 and for a uniform load  $w_u = 4.0$  K/ft on  $BC$ ,

$$M_B = M_C = -\frac{w_u L^2}{4K} = -\frac{4.0(40)^2}{4 \times 4.75} = -336.8 \text{ K} \cdot \text{ft}$$

The maximum positive bending moment at midspan of  $BC$  equals

$$w_u \frac{L^2}{8} + M_B = \frac{4.0(40)^2}{8} - 336.8 = 463.2 \text{ K} \cdot \text{ft}$$

The horizontal reaction at  $A$  is

$$H_a = H_D = \frac{M_B}{h} = \frac{336.8}{15} = 22.5 \text{ K}$$

The vertical reaction at  $A$  is

$$\begin{aligned} V_A = V_D &= \frac{w_u L}{2} + \text{weight of column} \\ &= 4.0 \times \frac{40}{2} + \frac{20}{12} \times \frac{16}{12} \times 0.150 \times 15 \text{ ft} = 85.0 \text{ K} \end{aligned}$$

The bending moment diagram is shown in Fig. 16.17.

e. To consider the sidesway effect on the frame, the live load is placed on half the beam  $BC$ , and the moments are calculated at the critical sections. This case is not critical in this example.

f. The maximum shear at the two ends of beam  $BC$  occurs when the beam is loaded with the factored load  $w_u$ , but the maximum shear at midspan occurs when the beam is loaded with half the live load and with the full dead load:

$$V_u \text{ at support} = 4.0 \times \frac{40}{2} = 80.0 \text{ K}$$

$$\begin{aligned} V_u \text{ at midspan} &= w_l \frac{L}{8} = (1.7 \times 80 \times 12) \times \frac{40}{8} \\ &= 8160 \text{ lb} = 8.16 \text{ K} \end{aligned}$$

g. The axial force in each column is  $V_A = V_D = 85.0$  K.

h. Let the point of zero moment in  $BC$  be at a distance  $x$  from  $B$ , then

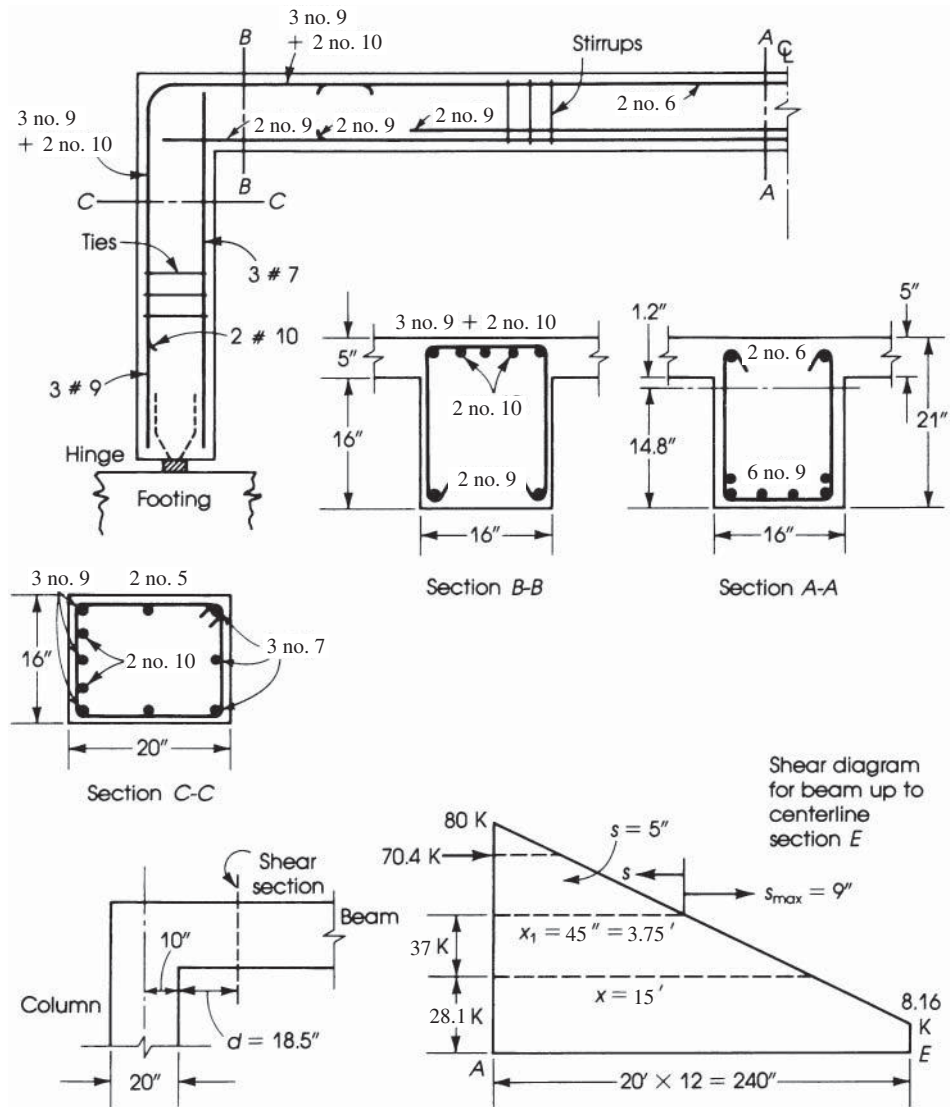
$$\begin{aligned} M_B &= w_u L \frac{x}{2} - w_u \frac{x^2}{2} \\ 336.8 &= 4.0 \left( \frac{40x}{2} - \frac{x^2}{2} \right) \quad \text{or} \quad x^2 - 40x + 168.4 = 0 \\ x &= 4.8 \text{ ft} = 57.6 \text{ in. from } B \end{aligned}$$

3. Design of girder  $BC$ :

a. Design the critical section at midspan.  $M_u = 463.2$  K · ft, web width is flange width is  $b_w = 16$  in., flange width is  $b = 96$  in., and  $d = 21 - 3.5 = 17.5$  in. (assuming two rows of steel bars). Check if the section acts as a rectangular section with effective  $b = 96$  in. Assume  $a = 1.0$  in., then

$$A_s = \frac{M_u}{\phi f_y (d - a/2)} = \frac{463.2 \times 12}{0.9 \times 60(17.5 - 1.0/2)} = 6.05 \text{ in.}^2$$

$$a = \frac{A_s f_y}{0.85 f'_c b} = \frac{6.05 \times 60}{0.85 \times 4 \times 96} = 1.1 \text{ in.} < 5.0 \text{ in.}$$



**Figure 16.18** Example 16.2: Reinforcement details of frame sections.

The assumed  $a$  equals approximately the calculated  $a$ . The section acts as a rectangular section; therefore, use six no. 9 bars. Check  $b_{\min}$  (to place bars in one row):

$$b_{\min} = 11 \left( \frac{9}{8} \right) + 2 \left( \frac{3}{8} \right) + 3 = 16.13 \text{ in.} > 16 \text{ in.}$$

Place bars in two rows, as shown in Fig. 16.18.

- b.** Design the critical section at joint  $B$ :  $M_u = 336.8 \text{ K} \cdot \text{ft}$ ,  $b = 16 \text{ in.}$ , and  $d = 21 - 2.5 = 18.5 \text{ in.}$  (for one row of steel bars). The slab is under tension, and reinforcement bars are placed on top of the section.

$$R_u = \frac{M_u}{bd^2} = \frac{336.8 \times 12,000}{16(18.5)^2} = 738 \text{ psi}$$

From tables in Appendix A,  $\rho = 0.016 < \rho_{\max} = 0.018$  (tension-controlled section,  $\phi = 0.9$ ):

$$A_s = 0.016 \times 16 \times 18.5 = 4.73 \text{ in.}^2$$

Use five no. 9 bars in one row.

**4.** Design the girder  $BC$  due to shear:

- a.** The critical section is at a distance  $d$  from the face of the column with a distance from the column centerline of  $10 + 18.5 = 28.5 \text{ in.} = 2.4 \text{ ft}$ . Thus,

$$V_u(\text{at distance } d) = 80 - 4 \times 2.4 = 70.4 \text{ K}$$

- b.** The shear strength provided by concrete is

$$\begin{aligned} \phi V_c &= \phi(2\lambda\sqrt{f'_c}) b_w d \\ &= \frac{0.75 \times 2 \times (1)}{1000} \times \sqrt{4000} \times 16 \times 18.5 = 28.1 \text{ K} \end{aligned}$$

The shear force to be provided by web reinforcement is

$$\phi V_s = V_u - \phi V_c = 70.4 - 28.1 = 42.3 \text{ K}$$

$$V_s = \frac{42.3}{0.75} = 56.4 \text{ K}$$

- c.** Choose no. 4 stirrups and  $A_v = 2 \times 0.20 = 0.40 \text{ in.}^2$ . Thus,

$$S = \frac{A_v f_y d}{V_s} = \frac{0.40 \times 60 \times 18.5}{56.4} = 7.8 \text{ in.} \quad \text{say, } 7 \text{ in.}$$

- d.** Maximum spacing of no. 4 stirrups is

$$S_{\max} = \frac{d}{2} = \frac{18.5}{2} = 9.25 \text{ in.} \quad \text{say, } 9 \text{ in.}$$

or

$$S_{\max} = \frac{A_v f_y}{50 b_w} = \frac{0.40 \times 60,000}{50 \times 16} = 30 \text{ in.}$$

Check for maximum spacing of  $d/2$ :  $V_s \leq 4\sqrt{f'_c} b_w d$  or

$$V_s \leq 4\sqrt{4000} \times \frac{16 \times 18.5}{1000} = 74.9 \text{ K}$$

The value  $V_s$  of 56.4 is less than 74.9 K, so use  $S_{\max} = 9 \text{ in.}$

$$V_s (\text{for } S_{\max} = 9 \text{ in.}) = \frac{A_v f_y d}{S} = \frac{0.40 \times 360 \times 18.5}{9} = 49.3 \text{ K}$$

$$\phi V_s = 0.75 \times 49.3 = 37 \text{ K}$$

The distance from the face of the column where  $S_{\max} = 9 \text{ in.}$  can be used is equal to  $45 \text{ in.} = 3.75 \text{ ft}$  (from the triangle of shear forces).

- e.** Distribution of stirrups:

First stirrups at  $S/2 = 3.0 \text{ in.}$

7 stirrups at  $7 \text{ in.} = 49.0 \text{ in.}$

19 stirrups at  $9 \text{ in.} = 171.0 \text{ in.}$  (total = 223 in.)

The distance from the face of the column to the centerline of the beam is  $240 - 10 = 230 \text{ in.}$

Use the same distribution for the second half of the beam, and place one stirrup at midspan.

- 5.** Design the column section at joint  $B$ :  $M_u = 336.8 \text{ K} \cdot \text{ft}$ ,  $P_u = 80 \text{ K}$ ,  $b = 16 \text{ in.}$ , and  $h = 20 \text{ in.}$

- a. Assuming that the frame under the given loads will not be subjected to sidesway, then the effect of slenderness may be neglected, and the column can be designed as a short column when

$$\frac{KL_u}{4} \leq 34 - \frac{12M_1}{M_2} \leq 40 \quad (\text{see Section 12.5})$$

$$M_1 = 0 \quad \text{and} \quad M_2 = 336.8 \text{ K} \cdot \text{ft}$$

Let  $K = 0.8$  (Fig. 12),  $L_u = 15 - 21/(2 \times 12) = 14.125$  ft, and  $r = 0.3 h = 0.3 \times 20 = 6$  in; then

$$\frac{KL_u}{r} = 0.8 \times \frac{14.125 \times 12}{6} = 22.6 < 34$$

If  $K$  is assumed equal to 1.0, then

$$\frac{KL_u}{r} = 28.25 < 34 < 40$$

Therefore, design the member as a short column.

- b. The design procedure is similar to 11.16 and 11.3:

$$\text{Eccentricity}(e) = \frac{M_u}{P_u} = \frac{336.8 \times 12}{80} = 50.5 \text{ in.}$$

This is a large eccentricity, and it will be assumed that the section is in the transition region,  $\phi < 0.9$ :

$$d = 20 - 2.5 = 17.5 \text{ in.}$$

- c. Because  $e = 50.5$  in. is much greater than  $d$ , determine approximate  $A_s$  and  $A'_s$  from the  $M_u$  only and then check the final section by statics, as was explained in Example 11.3. For  $M_u = 336.8$  K · ft,  $b = 16$  in.,  $h = 20$  in., and  $d = 17.5$  in.,  $R_u = M_u/bd^2 = 336.8(12,000)/16(17.5)^2 = 825$  psi.

$$\rho = 0.0183 \quad \text{and} \quad A_s = \rho bd = 0.0183(16)(17.5) = 5.12 \text{ in.}^2$$

Choose three no. 9 and two no. 10 bars and  $A_s = 5.53 \text{ in.}^2$ . Choose  $A'_s = A_s/3 = 5.13/3 = 1.7 \text{ in.}^2$  and three no. 7 bars ( $A'_s = 1.8 \text{ in.}^2$ ) (Fig. 16.18). When the eccentricity,  $e$ , is quite large, it is a common practice to use  $A'_s = A_s/3$  or  $A_s/2$  instead of  $A_s = A'_s$ .

- d. Check the load capacity of the final section using  $A_s = 5.53 \text{ in.}^2$  and  $A'_s = 1.8 \text{ in.}^2$ , similar to Example 11.3, according to the following steps:

- i.  $P_n = C_c + C_s - T$

$$C_c = 0.85 f'_c ab = 0.85(4)(16)a = 54.4a$$

$$C_s = A'_s(f'_s - 0.85 f'_c) = 1.8(60 - 0.85 \times 4) = 101.8 \text{ K}$$

$$T = A_s f_y = 5.53(60) = 331.8 \text{ K}$$

$$P_n = 54.4a + 101.8 - 331.8 = (43.4a - 230) \quad (\text{I})$$

- ii. Take moments about  $A_s$ :

$$P_n = \frac{1}{e'} \left[ C_c \left( d - \frac{a}{2} \right) + C_s (d - d') \right]$$

$e' = e + d''$ , where  $d''$  is the distance from  $A_s$  to the plastic centroid of the section. The plastic centroid occurs at 11.1 in. from the extreme compression fibers and  $d'' = d - x = 6.4$  in. (refer to Example 11.1):

$$e' = 50.5 + 6.4 = 56.9 \text{ in.}$$

$$\begin{aligned} P_n &= \frac{1}{56.9} \left[ 54.4a \left( 17.5 - \frac{a}{2} \right) + 101.8(15) \right] \\ &= 16.73a - 0.478a^2 + 26.86 \quad (\text{II}) \end{aligned}$$

- iii. Equate Eqs. I and II and solve to get  $a = 6.313$  in. and  $P_n = 113.5$  K. Check  $f'_s = 87(c - d')/c \leq f_y$ :  $c = a/0.85 = 7.43$  in. and  $f'_s = 87(7.43 - 2.5)/7.43 = 58$  ksi, which is close to the 60 ksi assumed in the calculations. Choose no. 3 ties spaced at 16 in.
- iv. Check  $\phi$ :  $d_t = 17.5$  in.

$$\epsilon_t = \left( \frac{d_t - c}{c} \right) 0.003 = 0.00407$$

$$\phi = 0.65 + (\epsilon_t - 0.002) \left( \frac{250}{3} \right) = 0.823$$

$$\phi P_n = 0.823(113.5) = 93.3 \text{ K} > 80 \text{ K}$$

The section is adequate.

6. Check the adequacy of the column section at midheight, 7.5 ft from A:  $M_u = 336.8/2 = 168.4$  K · ft.  
 $P_u = 80 + 2.5(\text{half the column weight}) = 82.5$  K

Use  $A_s =$  three no. 9 bars and  $A'_s =$  three no. 7 bars. In an approach similar to step 5,  $\phi P_n = 122$  K  $> 82.5$  K (no. 10 bars can be terminated, and they have to be extended a development length below the midheight of the column).

7. Design the hinge at A:  $M_u = 0$ ,  $H = 22.5$  K,  $P_u = 85$  K.

- a. Choose a Mesnager hinge. Using Eqs. 16.3a and Eqs. 16.3b,  $R_1 = 72$  K and  $R_2 = 27$  K. (Refer to Fig. 16.19 with  $\theta = 30^\circ$ )

$$A_{s1} = \frac{R_1}{0.55f_y} = \frac{72}{0.55 \times 60} = 2.2 \text{ in.}^2$$

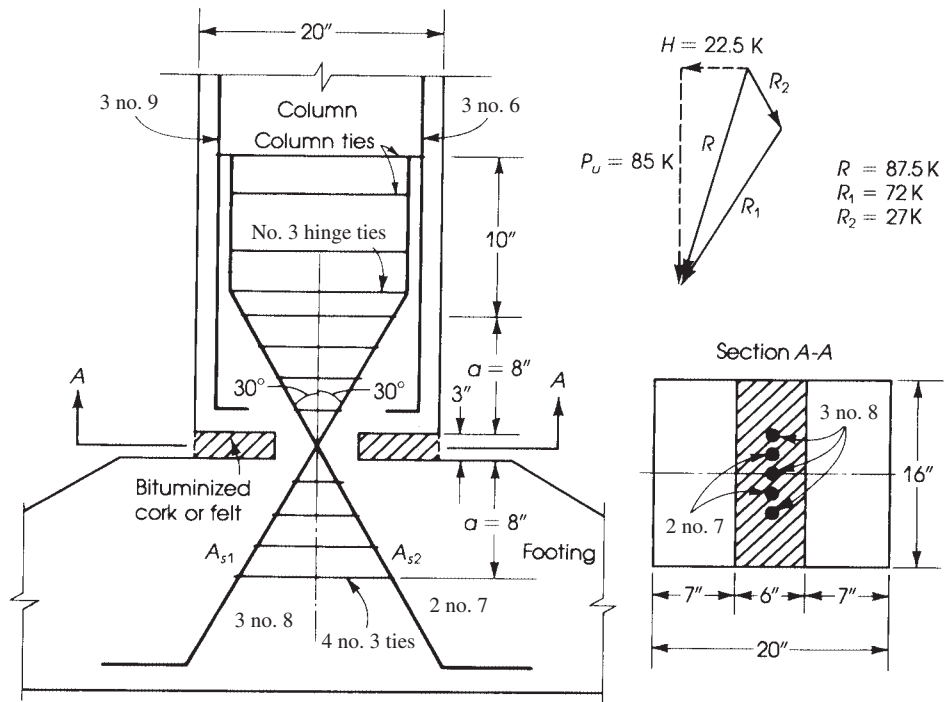


Figure 16.19 Example 16.2: Hinge details.

Choose three no. 8 bars ( $A_s = 2.35 \text{ in.}^2$ ).

$$A_{s2} = \frac{R_2}{0.55 \times f_y} = \frac{27}{0.55 \times 60} = 0.82 \text{ in.}^2$$

Choose two no. 7 bars ( $A_s = 1.2 \text{ in.}^2$ ). Arrange the crossing bars by placing one no. 8 bar and then one no. 7 bar, as shown in Fig. 16.19 (or use five no. 8 bars.)

- b. Lateral ties should be placed along a distance  $a = 8d_b = 8.0 \text{ in.}$  within the column and footing. The bursting force is

$$F = \frac{P_u}{2} \tan \theta + \frac{Ha}{0.85d}$$

For  $\theta = 30^\circ$ ,  $d = 17.5 \text{ in.}$ , and  $a = 8.0 \text{ in.}$ ,

$$F = \frac{85}{2} \tan 30^\circ + \frac{22.5 \times 8}{0.85 \times 17.5} = 36.6 \text{ K}$$

$$\text{Area of ties} = \frac{36.6}{0.85 \times 60} = 0.72 \text{ in.}^2$$

If no. 3 closed ties (two branches) are chosen, then the area of one tie is  $2 \times 0.11 = 0.22 \text{ in.}^2$ . The number of ties is  $0.72/0.22 = 3.27$ , say, four ties spaced at  $\frac{8}{3} = 2.7 \text{ in.}$ , as shown in Fig. 16.19.

8. Design the footing: If the height of the footing is assumed to be  $h'$ , then the forces acting on the footing are the axial load  $P$  and a moment  $M = H/h'$ . The soil pressure is calculated from Eq. 13.14 of Chapter 13:

$$q = +\frac{P}{A} \pm \frac{Mc}{I} \leq \text{allowable soil pressure}$$

The design procedure of the footing is similar to that of Example 13.7.

## 16.7 INTRODUCTION TO LIMIT DESIGN

### 16.7.1 General

Limit state design of a structure falls into three distinct steps:

1. Determination of the factored design load, obtained by multiplying the dead and live loads by load factors. The ACI Code adopted the load factors given in Chapter 3.
2. Analysis of the structure under factored loads to determine the factored moments and forces at failure or collapse of the structure. This method of analysis has proved satisfactory for steel design; in reinforced concrete design, this type of analysis has not been fully adopted by the ACI Code because of the lack of ductility of reinforced concrete members. The Code allows only partial redistribution of moments in the structure based on an empirical percentage, as will be explained later in this chapter.
3. Design of each member of the structure to fail at the factored moments and forces determined from structural analysis. This method is fully established now for reinforced concrete design and the ACI Code permits the use of the strength design method, as was explained in earlier chapters.

### 16.7.2 Limit Design Concept

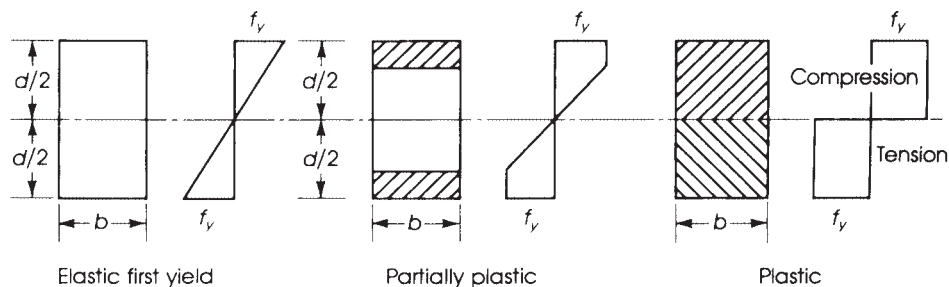
Limit design in reinforced concrete refers to the redistribution of moments that occurs throughout a structure as the steel reinforcement at a critical section reaches its yield strength. The ultimate

strength of the structure can be increased as more sections reach their strength capacity. Although the yielding of the reinforcement introduces large deflections, which should be avoided under service loads, a statically indeterminate structure does not collapse when the reinforcement of the first section yields. Furthermore, a large reserve of strength is present between the initial yielding and the collapse of the structure.

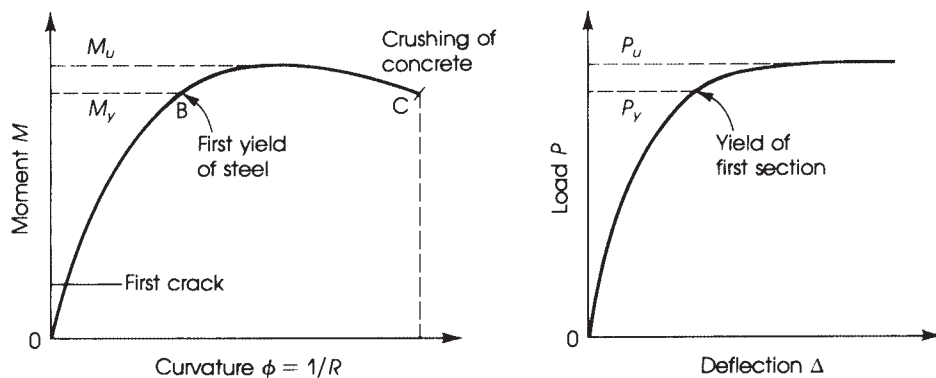
In steel design, the term *plastic design* is used to indicate the change in the distribution of moments in the structure as the steel fibers, at a critical section, are stressed to their yield strength. The development of stresses along the depth of a steel section under increasing load is shown in Fig. 16.20. Limit analysis of reinforced concrete developed as a result of earlier research on steel structures and was based mainly on the investigations of Prager and Hodge [4], Beedle et al. [5], and Baker et al. [6]. Baker [7] worked on the principles of limit design, whereas Cranston [8] tested portal frames to investigate the rotation capacity of reinforced concrete plastic hinges. However, more research work is needed before limit design can be adopted by the ACI Code.

### 16.7.3 Plastic Hinge Concept

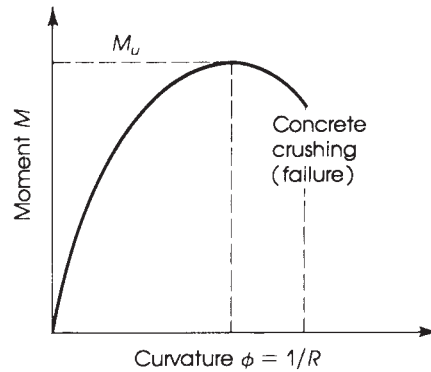
The curvature  $\phi$  of a member increases with the applied bending moment  $M$ . For an underreinforced concrete beam, the typical moment–curvature and the load–deflection curves are shown in Fig. 16.21. A balanced or an overreinforced concrete beam is not permitted by the ACI Code because it fails by the crushing of concrete and shows a small curvature range at factored moment (Fig. 16.22).



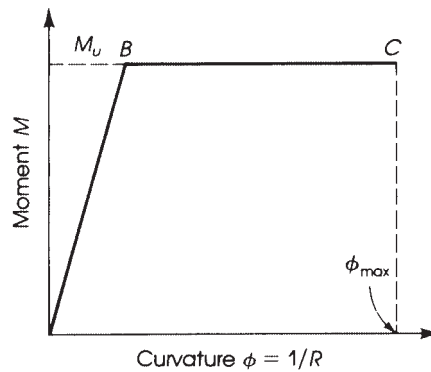
**Figure 16.20** Distribution of yield stresses in a yielding steel rectangular section.



**Figure 16.21** Yielding behavior of an underreinforced concrete beam.



**Figure 16.22** Yielding behavior of an overreinforced concrete beam.



**Figure 16.23** Idealized moment–curvature behavior of reinforced concrete beams.

The significant part of the moment–curvature curve in Fig. 16.21 is that between  $B$  and  $C$ , in which  $M_u$  remains substantially constant for a wide range of values of  $\phi$ . In limit analysis, the moment–curvature curve can be assumed to be of the idealized form shown in Fig. 16.23, where the curvature,  $\phi$ , between  $B$  and  $C$  is assumed to be constant, forming a plastic hinge. Because concrete is a brittle material, there is usually considered to be a limit at which the member fails completely at maximum curvature at  $C$ .

Cranston [8] reported that in normally designed reinforced concrete frames, ample rotation capacity is available, and the maximum curvature at point  $C$  will not be reached until the failure or collapse of the frame. Therefore, when the member carries a moment equal to its factored moment,  $M_u$ , the curvature continues to increase between  $B$  and  $C$  without a change in the moment, producing a plastic hinge. The increase in curvature allows other parts of the statically indeterminate structure to carry additional loading.

## 16.8 THE COLLAPSE MECHANISM

In limit design, the moment strength of a reinforced concrete member is reached when it is on the verge of collapse. The member collapses when there are sufficient numbers of plastic hinges to



transform it into a mechanism. The required number of plastic hinges,  $n$ , depends upon the degree of redundancy,  $r$ , of the structure. The relation between  $n$  and  $r$  to develop a mechanism is

$$n = 1 + r \tag{16.8}$$

For example, in a simply supported beam no redundants exist, and  $r=0$ . Therefore, the beam becomes unstable and collapses when one plastic hinge develops at the section of maximum moment, as shown in Fig. 16.24a. Applications to beams and frames are also shown in Fig. 16.24.

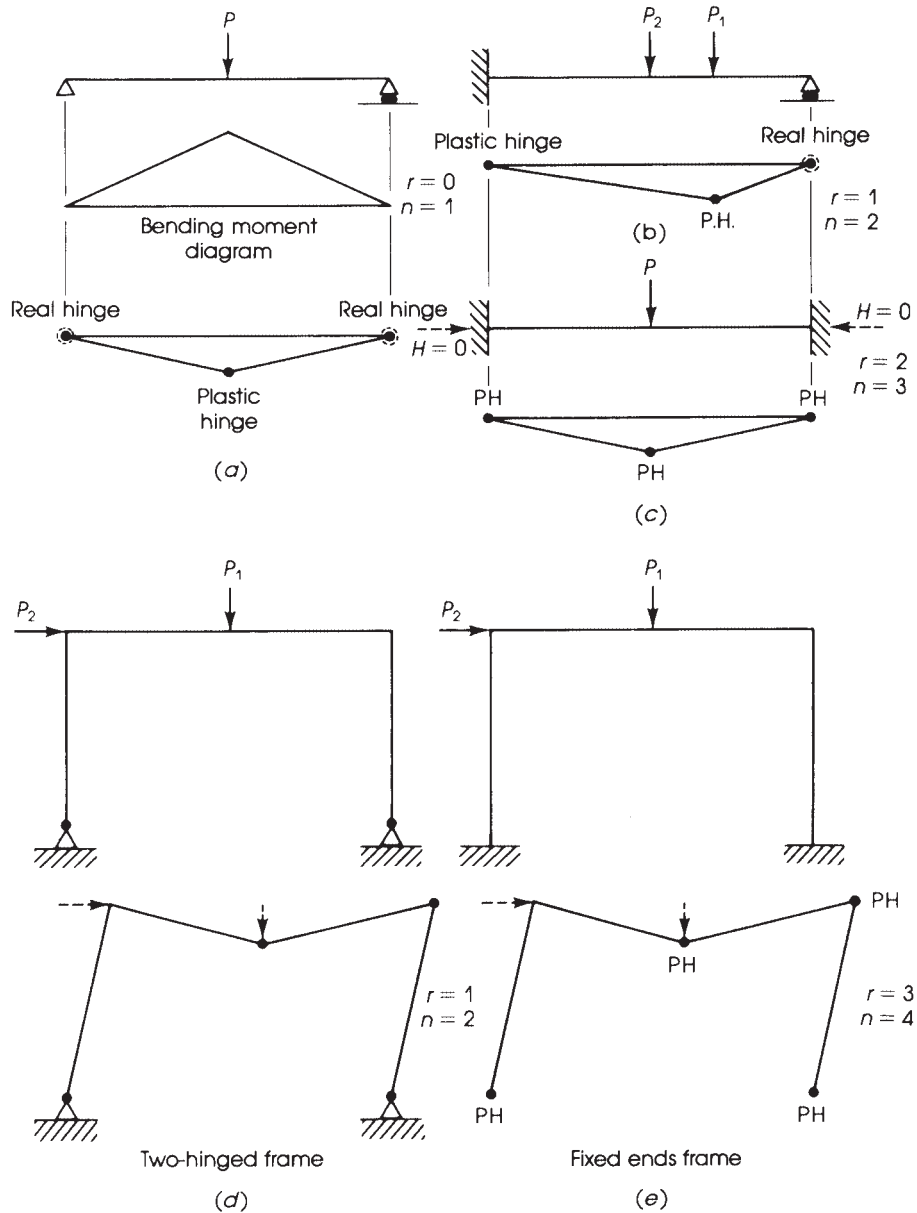


Figure 16.24 Development of plastic hinges (PH).

## 16.9 PRINCIPLES OF LIMIT DESIGN

Under working loads, the distribution of moments in a statically indeterminate structure is based on elastic theory, and the whole structure remains in the elastic range. In limit design, where factored loads are used, the distribution of moments at failure, when a mechanism is reached, is different from that distribution based on elastic theory. This change reflects moment redistribution.

For limit design to be valid, four conditions must be satisfied.

1. *Mechanism condition:* Sufficient plastic hinges must be formed to transform the whole or part of the structure into a mechanism.
2. *Equilibrium condition:* The bending moment distribution must be in equilibrium with the applied loads.
3. *Yield condition:* The factored moment must not be exceeded at any point in the structure.
4. *Rotation condition:* Plastic hinges must have enough rotation capacity to permit the development of a mechanism.

Only the first three conditions apply to plastic design because sufficient rotation capacity exists in ductile materials as steel. The fourth condition puts more limitations on the limit design of reinforced concrete members as compared to plastic design.

## 16.10 UPPER AND LOWER BOUNDS OF LOAD FACTORS

A structure on the verge of collapse must have developed the required number of plastic hinges to transform it into a mechanism. For arbitrary locations of the plastic hinges on the structure, the collapse loads can be calculated, which may be equal to or greater than the actual loads. Because the calculated loads cannot exceed the true collapse loads for the structure, then this approach indicates an upper or kinematic bound of the true collapse loads [10]. Therefore, if all possible mechanisms are investigated, the lowest  $M_u$  will be caused by the actual loads. Horne [11] explained the upper bound by assuming a mechanism and then calculating the external work,  $W_e$ , done by the applied loads and the internal work,  $W_i$ , done at the plastic hinges. If  $W_e = W_i$ , then the applied loads are either equal to or greater than the collapse loads.

If any arbitrary moment diagram is developed to satisfy the static equilibrium under the applied loads at failure, then the applied loads are either equal to or less than the true collapse loads. For different moment diagrams, different factored loads can be obtained. Higher values of the lower, or static, bound are obtained when the moments at several sections for the assumed moment diagram reach the collapse moment. Horne [11] explained the lower bound by assuming different moment distributions to obtain the one that is in equilibrium with the applied loads and satisfies the yield condition all over the structure. In this case, the applied loads are either equal to or less than the collapse loads.

## 16.11 LIMIT ANALYSIS

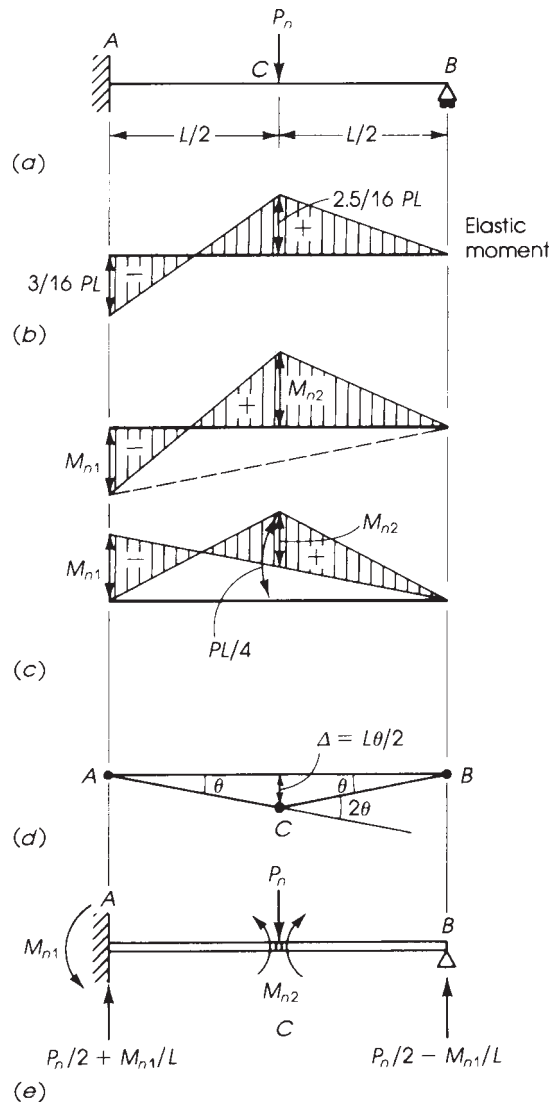
For the analysis of structures by the limit design procedure, two methods can be used: the virtual work method and the equilibrium method. In the virtual work method, the work done by the factored load,  $P_u$  (or  $w_u$ ), to produce a given virtual deflection,  $\Delta$ , is equated to the work absorbed at the plastic hinges. The external work done by loads is  $W_e = \Sigma(w_u \Delta)$  or  $\Sigma(P_u \Delta)$ . The work absorbed by the plastic hinges is internal work =  $W_i = \Sigma(M_u \theta)$ .

**Example 16.3**

The beam shown in Fig. 16.25 carries a concentrated load at midspan. Calculate the collapse moment at the critical sections.

**Solution**

1. The beam is once statically indeterminate ( $r=1$ ), and the number of plastic hinges needed to transform the beam into a mechanism is  $n=1+1=2$  plastic hinges, at A and C. The first plastic hinge develops at A, and the beam acts as a simply supported member until a mechanism is reached.



**Figure 16.25** Example 16.3:  $P_u = \phi P_n$  and  $M_u = \phi M_n$ .

2. If a rotation  $\theta$  occurs at the plastic hinge at the fixed end,  $A$ , the rotation at the sagging hinge is  $C = 2\theta$ . The deflection of  $C$  under the load is  $(L/2)\theta$  (Fig. 16.25).

$$W_e = \text{external work} = \sum P_u \Delta = P_u \left( \frac{L\theta}{2} \right)$$

$$W_i = \text{internal work} = \sum M_u \theta = M_{u_1}(\theta) + M_{u_2}(2\theta)$$

If the two sections at  $A$  and  $C$  have the same dimensions and reinforcement, then  $M_{u_1} = M_{u_2} = M_u$ , and  $W_i = 3M_u\theta$ . Equating  $W_e$  and  $W_i$ ,

$$M_{u_1} + 2M_{u_2} = P_u \frac{L}{2} = 3M_u \quad \text{and} \quad M_u = \frac{P_u L}{6}$$

### Example 16.4

Calculate the collapse moments at the critical sections for the beam shown in Fig. 16.26 due to a uniform load  $w_u$ .

### Solution

1. The number of plastic hinges is two.
2. For a deflection at  $C = 1.0$ , the rotation at  $A$ ,  $\theta_A$ , is  $1/a$ ;  $\theta_B = 1/b$ ; and

$$\theta_c = \theta_A + \theta_B = \frac{1}{a} + \frac{1}{b} = \frac{a+b}{ab} = \frac{L}{ab}$$

3. External work is

$$W_e = \sum w_u \Delta = w_u \left( \frac{1 \times L}{2} \right) = \frac{w_u L}{2}$$

Internal work is

$$\begin{aligned} W_i &= \sum M_u \theta = M_{u_1} \theta_A + M_{u_2} \theta_c \\ &= M_{u_1} \left( \frac{1}{a} \right) + M_{u_2} \left( \frac{1}{a} + \frac{1}{b} \right) \end{aligned}$$

Equating  $W_e$  and  $W_i$ ,

$$w_u = \frac{2}{L} \left( \frac{M_{u_1}}{a} + \frac{M_{u_2}}{a} + \frac{M_{u_2}}{L-a} \right) \quad (16.9)$$

If both moments are equal, then

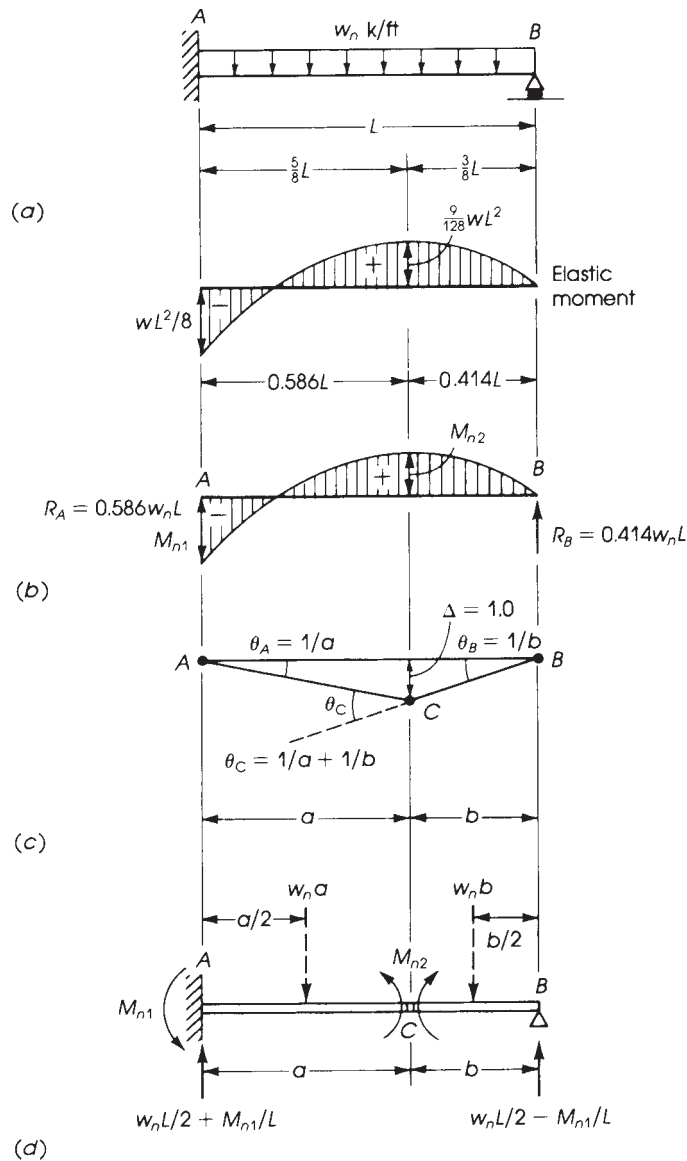
$$w_u = \frac{2M_u}{L} \left[ \frac{2}{a} + \frac{1}{L-a} \right] = \frac{2M_u}{L} \left[ \frac{(2L-a)}{a(L-a)} \right] \quad (16.10)$$

4. To determine the position of the plastic hinge at  $C$  that produces the minimum value of the collapse load  $w_u$ , differentiate Eq. 16.9 with respect to  $a$  and equate to 0:

$$\frac{\delta w_u}{\delta a} = 0 \quad - \left( \frac{M_{u_1}}{a^2} + \frac{M_{u_2}}{a^2} - \frac{M_{u_2}}{(L-a)^2} \right) = 0$$

If  $M_{u_1} = M_{u_2} = M_u$ , then

$$\frac{2}{a^2} = \frac{1}{(L-a)^2} \quad \text{or} \quad a = L(2 - \sqrt{2}) = 0.586L$$



**Figure 16.26** Example 16.4:  $M_u = \phi M_n$  and  $w_u = \phi w_n$ .

From Eq. 16.10, the collapse load is  $w_u = 11.66(M_u/L^2)$ , and the collapse moment is  $M_u = 0.085 w_u L^2$ . The reaction at A is  $0.586 w_u L$ , and the reaction at B is  $0.414 w_u L$ .

In the equilibrium method, the equilibrium of the beam or of separate segments of the beam is studied under the forces present at collapse. To illustrate analysis by this method, the two previous examples are repeated here.

**Example 16.5**

For the beam shown in Fig. 16.25, calculate the collapse moments using the equilibrium method.

**Solution**

Two plastic hinges will develop at  $A$  and  $C$ . Referring to Fig. 16.25e, the reaction at  $A$  is  $(P_u/2) + (M_{u1}/L)$  and the reaction at  $B$  is  $(P_u/2) - (M_{u1}/L)$ .

Considering the equilibrium of beam  $BC$  and taking moments about  $C$ ,

$$\left( \frac{P_u}{2} - \frac{M_{u1}}{L} \right) \left( \frac{L}{2} \right) = M_{u2}$$

$$M_{u1} + 2M_{u2} = P_u \frac{L}{2}$$

which is the same equation obtained in Example 16.3. When  $M_{u1} = M_{u2} = M_u$ , then

$$3M_u = P_u \frac{L}{2} \quad \text{or} \quad M_u = P_u \frac{L}{6}$$

**Example 16.6**

Calculate the collapse moments for the beam shown in Fig. 16.26 by the equilibrium method.

**Solution**

- Two plastic hinges will develop in this beam at  $A$  and  $C$ . Referring to Fig. 16.26d, the reaction at  $A = w_u(L/2) + (M_{u1}/L)$  and the reaction at  $B = w_u(L/2) - (M_{u1}/L)$ . The load on  $BC$  is  $w_u b$  acting at  $b/2$  from  $B$ , and  $b = (L - a)$ . Considering the equilibrium of segment  $BC$  and taking moments about  $C$ ,

$$\left( w_u \frac{L}{2} - \frac{M_{u1}}{L} \right) b - (w_u b) \frac{b}{2} = M_{u2}$$

If  $M_{u1} = M_{u2} = M_u$ , then

$$w_u \frac{b}{2} (L - b) = M_u \left( 1 + \frac{b}{L} \right) = \frac{M_u}{L} (2L - a)$$

$$w_u = \frac{2M_u}{L} \times \frac{2L - a}{a(L - a)}$$

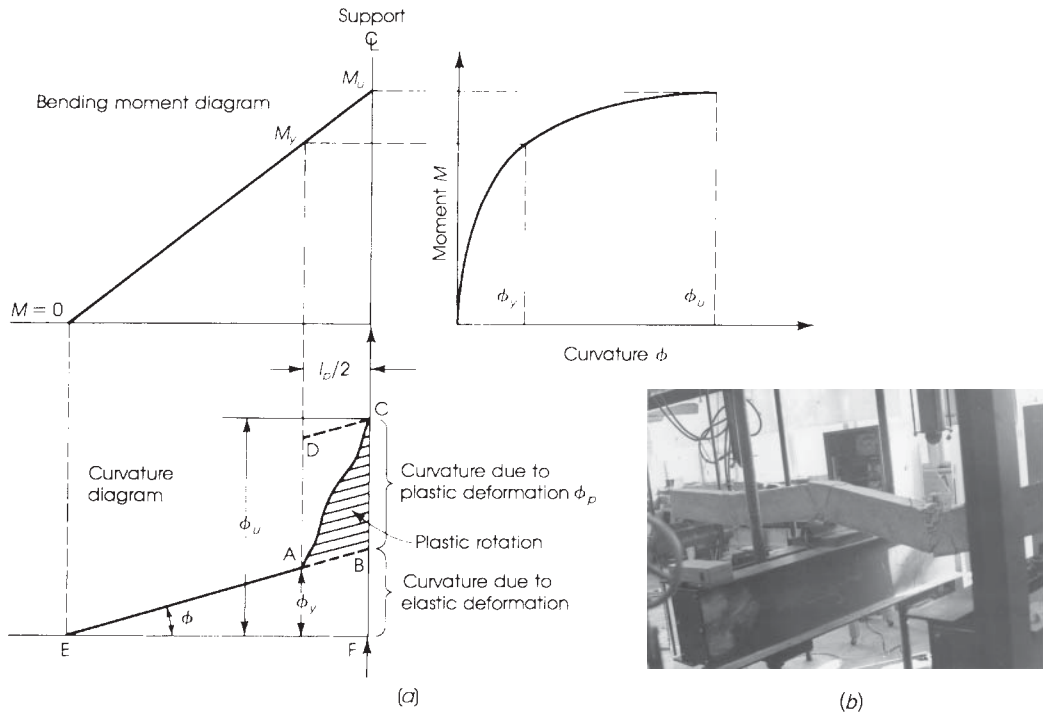
which is similar to the results obtained in Example 16.4.

$$M_u = \frac{w_u L}{2} \times \frac{a(L - a)}{2L - a}$$

- The position of  $a$  can be determined as before, where  $a = 0.586L$ ,  $M_u = 0.0858 w_u L^2$ , and  $w_u = 11.66(M_u/L^2)$ .

**16.12 ROTATION OF PLASTIC HINGES****16.12.1 Plastic Hinge Length**

The assumption that the inelastic rotation of concrete occurs at the point of maximum moment while other portions of the member act elastically is a theoretical one; in fact, the plastic rotation



**Figure 16.27** (a) Plastic rotation from moment–curvature and moment gradient and (b) development of plastic hinges in a reinforced concrete continuous beam.

occurs on both sides of the maximum moment section over a finite length. This length is called the plastic hinge length,  $l_p$ . The hinge length,  $l_p$ , is a function of the effective depth  $d$ , and the distance from the section of highest moment to the point of contraflexure (zero moment).

Referring to Fig. 16.27a, the length  $L_p/2$  represents the plastic hinge length on one side of the center of support;  $M_u$  and  $\phi_u$  indicate the factored moment and ultimate curvature at the critical section, whereas  $M_y$  and  $\phi_y$  indicate the moment and curvature at first yield. The plastic curvature at the critical section  $\phi_p$  is equal to  $\phi_u - \phi_y$  and the rotation capacity is equal to  $\phi_p l_p$ .

The estimated length of the plastic hinge was reported by many investigators. Baker [7] assumed that the length of the plastic hinge is approximately equal to the effective depth  $d$ . Corley [12] proposed the following expression for the equivalent length of the plastic hinge:

$$l_p = 0.5d + 0.2\sqrt{d} \left( \frac{z}{d} \right) \quad (16.11)$$

where  $z$  is the distance of the critical section to the point of contraflexure and  $d$  is the effective depth of the section. Mattock [13] suggested a simpler form:

$$l_p = 0.5d + 0.05z \quad (16.12)$$

Tests [14] on reinforced concrete continuous beams showed that  $l_p$  can be assumed equal to  $1.06d$ . They also showed that the length of the plastic hinge, in reinforced concrete continuous beams containing hooked-end steel fibers, increases with the increase in the amount of the steel fibers and the main reinforcing steel according to the following expression:

$$l_p = (1.06 + 0.13\rho\rho_s)d \quad (16.13)$$

where  $\rho$  is the percentage of main steel in the section and  $\rho_s$  is the percentage of steel fibers by volume,  $0 \leq \rho_s$ . For example, if  $\rho = 1.0\%$  and  $\rho_s = 0.8\%$ , then  $l_p = 1.164d$ .

### 16.12.2 Curvature Distribution Factor

Another important factor involving the calculation of plastic rotations is the curvature distribution factor,  $\beta$ . The curvature along the plastic hinge varies significantly, and in most rotation estimations this factor is ignored, which leads to an overestimation of the plastic rotations. Referring to Fig. 16.27, the shaded area,  $ABC$ , represents the inelastic rotation that can occur at the plastic hinge, whereas the unshaded area,  $EBF$ , represents the elastic contribution to the rotation over the length of the member. The shaded area  $ABC$  can be assumed to be equal to  $\beta$  times the total area  $ABCD$  within the plastic hinge length,  $l_p/2$ , on one side of the critical section. The curvature distribution factor,  $\beta$ , represents the ratio of the actual plastic rotation,  $\theta_{pc}$ , to  $\phi l_p$ , where  $\phi$  is the curvature and  $l_p$  is the length of the plastic hinge. The value of  $\beta$  was reported to vary between 0.5 and 0.6. Tests [14] have showed that  $\beta$  can be assumed to be equal to 0.56. When hooked-end steel fibers were used in concrete beams, the value of  $\beta$  decreased according to the following expression:

$$\beta = 0.56 - 0.16\rho_s \quad (16.14)$$

where  $\rho_s$  is the percentage of steel fibers,  $0 \leq \rho_s \leq 1.2\%$ . The reduction of the curvature distribution factor of fibrous concrete does not imply that the rotation capacity is reduced: The plastic curvature of fibrous concrete is substantially higher than that of concrete without fibers. Figure 16.28 shows the distribution of the curvature along the plastic hinge length. The area  $ABC_1$  represents the plastic rotation for concrete that does not contain steel fibers,  $\beta = 0.56$ , whereas the areas  $ABC_2$  and  $ABC_3$  represent the plastic rotation for concretes containing 0.8 and 1.2% steel fibers, respectively.

### 16.12.3 Ductility Index

The ratio of ultimate to first-yield curvature is called the *ductility index*,  $\mu = \phi_u/\phi_y$ . The ductility index of reinforced concrete beams was reported [15] to vary between 4 and 6. If steel fibers are used in concrete beams, the ductility index increases according to the following expression [14]:

$$\mu' = (1.0 + 3.8\rho_s)\mu \quad (16.15)$$

where

$\mu$  = ratio of ultimate to first-yield curvature

$\mu'$  = ductility index of fibrous concrete

$\rho_s$  = percentage of steel fibers by volume,  $0 \leq \rho_s \leq 1.2\%$

### 16.12.4 Required Rotation

The rotation of a plastic hinge in a reinforced concrete indeterminate structure is required to allow other plastic hinges to develop, and the structure to reach a mechanism can be determined by slope deflection from the following expression [7,20]. For a segment  $AB$  between two plastic hinges, the rotation at  $A$  is

$$\theta_A = \frac{L}{6E_c I} [2(M_A - M_{FA}) + (M_B - M_{FB})] \quad (16.16)$$

where

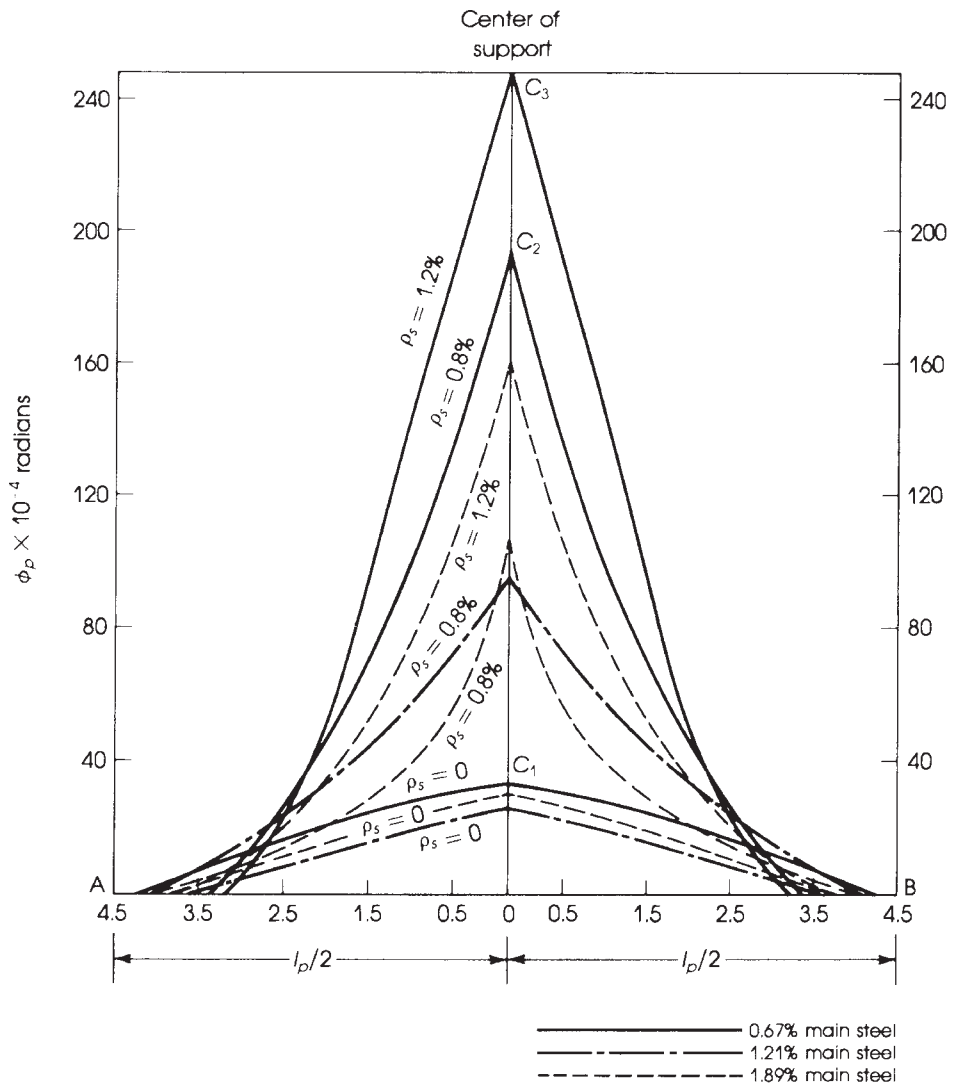
$M_A, M_B$  = factored moments at  $A$  and  $B$ , respectively

$M_{FA}, M_{FB}$  = elastic fixed-end moments at  $A$  and  $B$

$E_c$  = modulus of elasticity of concrete =  $33w^{1.5}\sqrt{f'_c}$

$I$  = moment of inertia of cracked section (Chapter 5)





**Figure 16.28** Curvature distribution along the plastic hinge.

### 16.12.5 Rotation Capacity Provided

Typical tensile plastic hinges at the support and midspan sections of a frame are shown in Fig. 16.29. The rotation capacity depends mainly on the following:

1. The ultimate strain capacity of concrete,  $\epsilon'_c$ , which may be assumed to be 0.003 or 0.0035, as used by Baker [7].
2. The length,  $l_p$ , over which yielding occurs at the plastic hinge, which can be assumed to be approximately equal to the effective depth of the section where the plastic hinge developed ( $l_p = d$ ).

3. The depth of the compressive block  $c$  in concrete at failure at the section of the plastic hinge. Baker [7] estimated the angle of rotation,  $\theta$ , of a tensile plastic hinge as follows:

$$\theta = \frac{\epsilon_p I_p}{c} \tag{16.17}$$

where  $\epsilon_p$  is the increase in the strain in the concrete measured from the initial yielding of steel reinforcement in the section (see Fig. 16.29c):

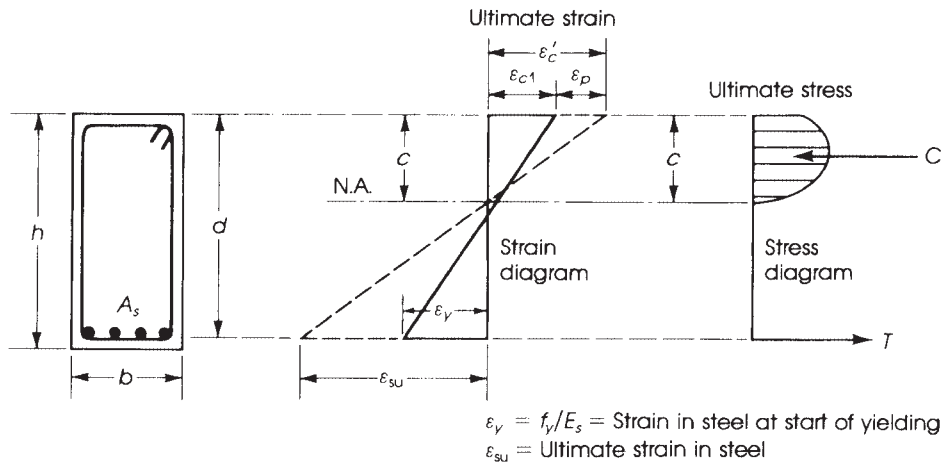
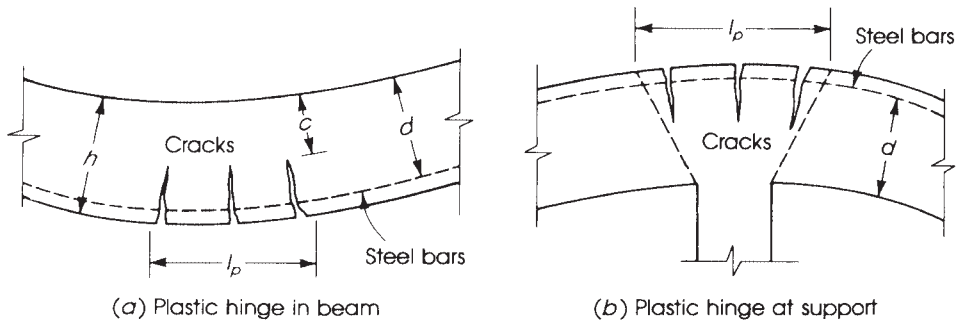
$$\epsilon_p = \epsilon'_c - \epsilon_{c1} = 0.0035 - \epsilon_{c1}$$

If  $l_p = d$  and the ratio  $c/d$  equals  $\lambda \leq 0.5$ ,

$$\theta = \frac{(0.0035 - \epsilon_{c1})d}{\lambda d} = \frac{0.0035 - \epsilon_{c1}}{\lambda}$$

From strain triangles (Fig. 16.29),

$$\epsilon_{c1} = \epsilon_y \left( \frac{c}{d - c} \right) = \frac{f_y}{E_s} \left( \frac{\lambda d}{d - \lambda d} \right) = \frac{f_y}{E_s} \left( \frac{\lambda}{1 - \lambda} \right)$$



(c) Stress and strain diagrams

**Figure 16.29** Plastic hinge and typical stress and strain distribution [2].

where  $f_y$  is the yield strength of steel bars and  $E_s$  is the modulus of elasticity of steel =  $29 \times 10^6$  psi. Therefore,

$$\theta = \frac{0.0035}{\lambda} - \frac{\epsilon_{c1}}{\lambda} = \frac{0.0035}{\lambda} - \frac{f_y}{E_s(1-\lambda)} \quad (16.18)$$

For grade 40 steel,  $f_y = 40$  ksi, and using a maximum value of  $\lambda$  of 0.50, then

$$\theta_{\min} = \frac{0.0035}{0.50} - \frac{40}{29,000 \times (1-0.50)} = 0.00424 \text{ rad}$$

For grade 60 steel,  $f_y = 60$  ksi and  $\lambda_{\max} = 0.44$ ;

$$\theta_{\min} = \frac{0.0035}{0.44} - \frac{60}{29,000(1-0.44)} = 0.00426 \text{ rad}$$

The  $\theta_{\min}$  calculated here is from one side only, and the total permissible rotation at the plastic hinge equals  $2\theta$  or  $2\theta_{\min}$ . The actual  $\lambda$  can be calculated as follows, given  $\alpha = \beta_1 c$  and  $\beta_1 = 0.85$  for  $f'_c \leq 4$  ksi:

$$c = \frac{a}{0.85} = \frac{A_s f_y}{(0.85)^2 f'_c b}$$

$$\lambda = \frac{c}{d} = \frac{A_s f_y}{0.72 f'_c b d} = \frac{\rho f_y}{0.72 f'_c} \leq 0.5 \quad (16.19)$$

where  $\rho = A_s/bd$ . ( $\lambda_{\max}$  is obtained when  $\rho_{\max}$  is used.)

If the rotation provided is not adequate, one can increase the section dimensions or reduce the percentage of steel reinforcement to obtain a smaller  $c$ , a smaller  $\lambda$ , and greater  $\theta$ . Baker [3] indicated that if special binding or spirals are used, the ultimate crushing strain in bound concrete may be as high as 0.012.

For a compression plastic hinge (as in columns),

$$\theta = \frac{\epsilon_p l_p}{h} \quad (16.20)$$

where  $h$  is the overall depth of the section and  $l_p$  is the length over which yielding occurs. In compression hinges,  $l_p$  varies between  $0.5h$  and  $h$ .

At a concrete ultimate stress of  $f'_c$ ,  $\epsilon_c = 0.002$ ; thus,  $\epsilon_p = \epsilon'_c - 0.002 = 0.0035 - 0.002 = 0.0015$  is the minimum angle of rotation on one side. Therefore,

$$\theta_{\min} = \frac{0.0015 \times 0.5h}{h} = 0.00075 \text{ rad}$$

With special binding or spirals,  $\theta$  may be increased to

$$\theta_{\max} = (0.012 - 0.002) \times \frac{0.5h}{h} = 0.005 \text{ rad}$$

The extreme value of  $\epsilon'_c = 0.012$  is quite high, and a smaller value may be used with proper spirals; otherwise a different section must be adopted.

In reinforced concrete continuous beams containing steel fibers, the plastic rotation may be estimated as follows [14]:

$$\theta_p = \lambda \beta \left( \frac{0.0035}{\lambda} - \frac{f_y}{E_s(1-\lambda)} \right) \quad (16.21)$$

where

$$\lambda = (4.3 + 2.24\rho_s - 0.043f_y + 4.17\rho\rho_s) \quad (16.22)$$

$$\beta = 0.56 - 0.16\rho_s \quad (16.14)$$

and

$f_y$  = yield strength of steel, ksi

$E_s$  = modulus of elasticity of main steel

$\rho$  = percentage of main steel

$\rho_s$  = percentage of steel fibers



A plastic hinge in the maximum negative moment region.

From Eq. 16.21, it is obvious that the plastic rotation of fibrous reinforced concrete is dependent upon the percentage of steel fibers and percentage of the main steel and its yield strength. Raising the yield strength of the main steel reduces the plastic rotation. Equation 16.21 also includes the effect of the plastic hinge length on rotation.

A simplified form can be presented [14]:

$$\theta_p = \lambda \beta \left( \frac{0.003}{\lambda} \right) \quad (16.23)$$

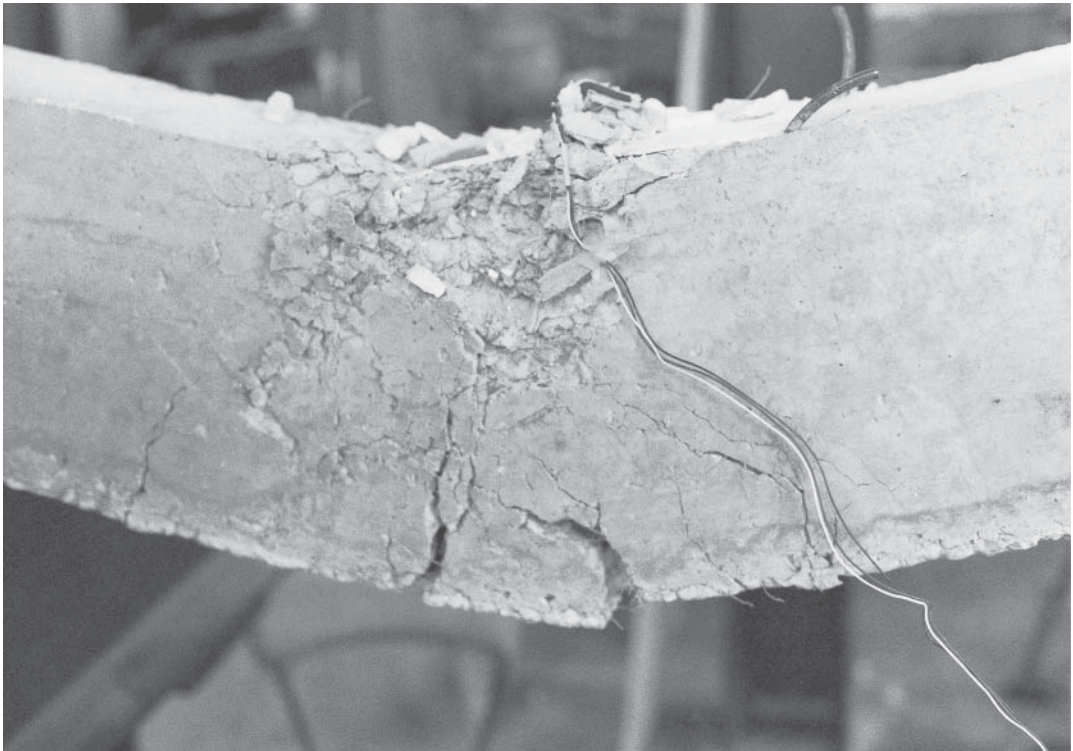
For example, if  $\rho_s = 0$  and  $f_y = 60$  ksi, then  $\theta_{p1} = 0.00289/\lambda$ , and if  $\rho_s = 1.0\%$ ,  $\rho = 1.5\%$ , and  $f_y = 60$  ksi, then  $\theta_{p2} = 0.01222/\lambda$ . This means that the rotation capacity of a concrete beam may be increased by about four times if 1% of steel fibers is used.

**16.13 SUMMARY OF LIMIT DESIGN PROCEDURE**

1. Compute the factored loads using the load factors given in Chapter 3:

$$w_u = 1.2D + 1.6L$$

2. Determine the mechanism, plastic hinges, and factored moments  $M_u$ .



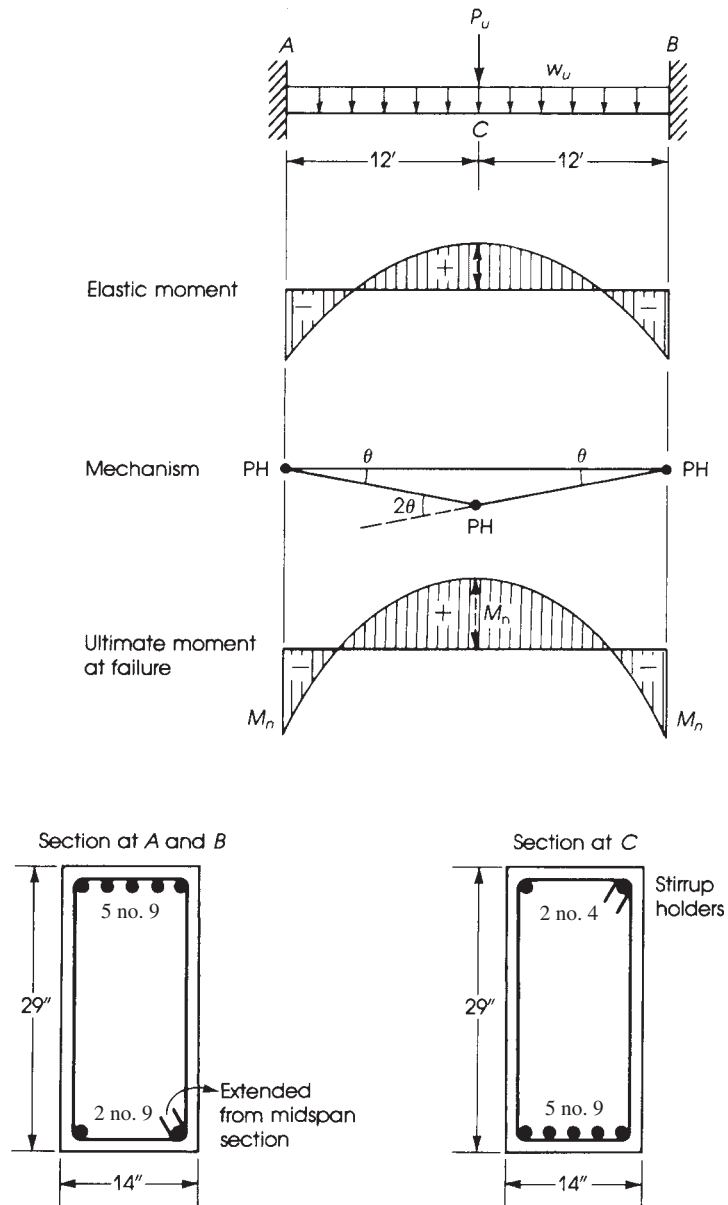
A plastic hinge in the maximum positive moment region.

3. Design the critical sections using the strength design method.
4. Determine the required rotation of plastic hinges.
5. Calculate the rotation capacity provided at the sections of plastic hinges. The rotation capacity must exceed that required.
6. Check the factor against yielding of steel and excessive cracking, that is,  $\phi M_u$ /elastic moment at service load.
7. Check deflection and cracking under service loads.
8. Check that adequate shear reinforcement is provided at all sections.

For more details, see Ref. 21.

**Example 16.7**

The beam shown in Fig. 16.30 is fixed at both ends and carries a uniform factored load of 5.5 K/ft, and a concentrated factored load of 48 K. Design the beam using the limit design procedure. Use  $b = 14$  in.,  $f'_c = 3$  ksi, and  $f_y = 40$  ksi.



**Figure 16.30** Example 16.7.

**Solution**

1. Factored uniform load  $w_u = 5.5$  K/ft. Factored concentrated load  $P_u = 48$  K.
2. The plastic hinges will develop at  $A$ ,  $B$ , and  $C$ , causing the mechanism shown in Fig. 16.30. Using the virtual work method of analysis and assuming a unit deflection at  $C$ , then the external work is equal to

$$W_e = 48 \times 1 + 5.5 \left( 24 \times \frac{1}{2} \right) = 114 \text{ K} \cdot \text{ft}$$

The internal work absorbed by the plastic hinges is

$$\begin{aligned} W_i &= M_u \theta (\text{at } A) + M_u \theta (\text{at } B) + M_u (2\theta) \text{ at } C \\ &= 4M_u \theta = 4M_u \left( \frac{1}{12} \right) = \frac{M_u}{3} \end{aligned}$$

Equating  $W_e$  and  $W_i$  gives  $M_u = 342$  K · ft. The general analysis gives directly

$$M_u = \frac{w_u L^2}{16} + P_u \frac{L}{8} = \frac{5.5}{16} (24)^2 + 48 \frac{24}{8} = 342 \text{ K} \cdot \text{ft}$$

3. Design the critical sections at  $A$ ,  $B$ , and  $C$  for  $M_u = 342$  K · ft. From tables in Appendix A and for  $f'_c = 3$  ksi,  $f_y = 40$  ksi, and a steel percentage  $\rho = 0.013$ ,  $R_u = 420$  psi ( $\rho_{\max} = 0.0203$ ).

$$M_u = R_u b d^2$$

$$342 \times 12 = 0.42 \times 14 (d)^2$$

Where

$d$  is 26.4 in. and the total depth  $h = 26.4 + 2.5 = 28.9$  in., say, 29 in.,

$$A_s = \rho b d = 0.013 \times 14 \times 26.4 = 4.8 \text{ in.}^2$$

Use five no. 9 bars in one row;  $A_s$  provided = 5.0 in.<sup>2</sup>,  $b_{\min} = 13.875$  in. < 14 in.

$$a = \frac{A_s f_y}{0.85 f'_c b} = \frac{5.0 \times 40}{0.85 \times 3 \times 14} = 5.6 \text{ in.}$$

$$c = \frac{a}{0.85} = 6.6 \text{ in.} \quad \lambda = \frac{c}{d} = \frac{6.6}{26.4} = 0.25$$

4. The required rotation of plastic hinges is as follows:

**a.**

$$\theta_A = \frac{L}{6E_c I} [2(M_A - M_{FZ}) + (M_B - M_{FB})]$$

$$E_c = 57,400 \sqrt{f'_c} = 3.144 \times 10^6 \text{ psi}$$

$$E_s = 29 \times 10^6 \text{ psi} \quad \text{and} \quad n = \frac{E_s}{E_c} = 9.2$$

- b.** Determine the fixed end moments at  $A$  and  $B$  using factored loads:

$$M_{FA} = M_{FB} = \frac{w_u L^2}{12} (\text{uniform load}) + \frac{P_u L}{8} (\text{concentrated load})$$

$$= 5.5 \frac{(24)^2}{12} + 48 \times \frac{24}{8} = 408 \text{ K} \cdot \text{ft}$$

$$\text{Plastic } M_A = \text{plastic } M_B = 342 \text{ K} \cdot \text{ft}$$

- c. The cracked moment of inertia can be calculated from

$$I_{cr} = b \frac{x^3}{3} + nA_s(d-x)^2$$

where  $x$  is the distance from compression fibers to the neutral axis ( $kd$ ). To determine  $x$  (see Chapter 6),  $x = 10.3$  in. and  $I_{cr} = 17,172$  in.<sup>4</sup>

- d. Required minimum rotation: Considering all moments at supports  $A$  and  $B$  are negative, then

$$\theta_A = \frac{24 \times 12}{6 \times 3.144 \times 10^6 \times 17,172} [2(-342 + 408) + (-342 + 408)](12,000) = 0.00211 \text{ rad}$$

5. The rotation capacity provided is

$$\begin{aligned} \theta_A &= \frac{0.0035}{\lambda} - \frac{f_y}{E_s(1-\lambda)} = \frac{0.0035}{0.25} - \frac{40}{29,000(1-0.25)} \\ &= 0.0122 \text{ rad} > 0.00211 \text{ required} \end{aligned}$$

The rotation capacity provided is about 5.5 times that required, indicating that the section is adequate.

6. Check the ratio of factored to elastic moment at service load:

$$\begin{aligned} M_A = M_B &= \frac{wL^2}{12} + \frac{PL}{8} \\ &= 3.5 \frac{(24)^2}{12} + \frac{30 \times 24}{8} = 258 \text{ K} \cdot \text{ft} \end{aligned}$$

Actual  $\phi M_n = \phi A_s f_y [d - (a/2)] = 0.9 \times 5 \times 40 [26.5 - (5.6/2)] / 12 = 356 \text{ K} \cdot \text{ft}$ . The ratio is  $356/258 = 1.38$ , which represents the factor of safety against the yielding of steel bars at the support.

7. Check maximum deflection due to service load (at midspan): Let the uniform service load  $w = 3.5$  K/ft, and  $P = 30$  K. Then:

$$\Delta_1 = \frac{wL^4}{384 EI}$$

For a concentrated load at midspan,

$$\Delta_2 = \frac{PL^3}{192 EI}$$

and total deflection is

$$\begin{aligned} \Delta &= \frac{(3500/12)(24 \times 12)^4}{384(17,172)(3.144 \times 10^6)} + \frac{30,000(24 \times 12)^3}{192(17,172)(3.144 \times 10^6)} = 0.166 \text{ in.} \\ \frac{\Delta}{L} &= \frac{0.166}{24 \times 12} = \frac{1}{1735} \end{aligned}$$

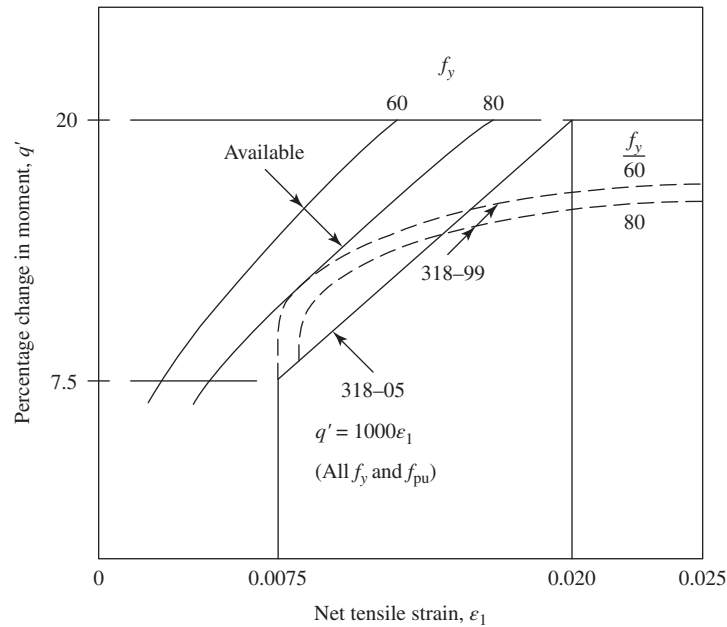
which is a very small ratio.

8. Adequate shear reinforcement must be provided to avoid any possible shear failure.

## 16.14 MOMENT REDISTRIBUTION OF MAXIMUM NEGATIVE OR POSITIVE MOMENTS IN CONTINUOUS BEAMS

Moment redistribution of maximum positive or negative moments in continuous flexural members is based on the net tensile strain (NTS),  $\epsilon_t$ , for both reinforced and prestressed concrete members. Figure 16.31 shows the permissible limits on moment redistribution. It indicates that the percentage





**Figure 16.31** Permissible moment redistribution for minimum rotation capacity [22].  
Courtesy of ACI-PCA

decrease in the negative moments at supports and positive moments between supports of continuous beam,  $q'$ , calculated by the elastic theory, must not exceed  $(1000 \epsilon_t)\%$ , with maximum of 20%. Moment redistribution is allowed only when  $\epsilon_t \geq 0.0075$ , indicating adequate ductility is available at the section at which moment is reduced. When  $\epsilon_t < 0.0075$ , no moment redistribution is allowed. The modified negative moments must be used to calculate the modified positive moments within the span, ACI Code, Section 6.6.5.1. Moment redistribution does not apply to members designed by the direct design method for slab systems. (Refer to Chapter 17.)

In summary, the percentage of decrease in maximum negative or positive moments in continuous beams is as follows:

1. When  $\epsilon_t \geq 0.0075$ , moment redistribution is allowed ( $\rho/\rho_b > 0.476$ ).
2. When  $\epsilon_t = 0.0075$ , the percentage of moment redistribution is 75% ( $\rho/\rho_b = 0.476$ ).
3. When  $\epsilon_t \geq 0.020$ , the percentage of moment redistribution is 20% ( $\rho/\rho_b = 0.217$ ).
4. When  $0.0075 < \epsilon_t < 0.020$ , the percentage of moment redistribution is

$$q' = 1000\epsilon_t \quad (16.24)$$

For example, if  $\epsilon_t = 0.010$ , then the percentage of moment redistribution is 10%. The relationship between the steel percentage,  $\rho$ , in the section and the net tensile strain,  $\epsilon_t$ , is as follows (refer to Section 3.10):

$$\epsilon_t = \left( \frac{0.003 + f_y/E_s}{\rho/\rho_b} \right) - 0.003 \quad (\text{Eq. 3.24})$$

**Table 16.1** Percentage Change in Moment Redistribution ( $q'$ ),  $f_y = 60$  ksi

$\varepsilon_t$	0.0075	0.0100	0.0125	0.0150	0.0175	0.0200	0.0225
$\rho/\rho_b$	0.476	0.385	0.323	0.278	0.244	0.217	0.196
$q'$ %	7.5	10.0	12.5	15.0	17.5	20.0	20.0

**Table 16.2** Percentage Change in Moment Redistribution ( $q'$ ) for a Given  $\rho/\rho_b$  Ratio

$\rho/\rho_b$	0.48	0.45	0.40	0.35	0.30	0.25	0.20
$\varepsilon_t$	0.0074	0.0081	0.0095	0.0113	0.0137	0.017	0.022
$q'$ %	0.0	8.1	9.5	11.3	13.7	17.0	20.0

For grade 60 steel,  $f_y = 60$  ksi and  $E_s = 29,000$  ksi. Assuming  $f_y/E_s = 0.002$ , then

$$\varepsilon_t = \left( \frac{0.005}{\rho/\rho_b} \right) - 0.003 \quad (\text{Eq. 3.25})$$

For  $\varepsilon_t = 0.0075$ , the ductility limit  $\varepsilon_t/\varepsilon_y = 0.0075/0.002 = 3.75$ . The percentage change in moment redistribution according to these limitations and for  $f_y = 60$  ksi is given in Tables 16.1 and 16.2.

Whatever percentage of moment redistribution is used, it is essential to ensure that no section is likely to suffer local damage or excessive cracking at service loads and that adequate rotation capacity is maintained at every critical section in the structure. The redistribution of moments in a statically indeterminate structure will result in a reduction in the negative moments at the supports and in the positive moments within the spans. This reduction will not imply that the safety of the structure has been reduced or jeopardized as compared with determinate structures. In fact, continuity in structures provides additional strength, stability and economy in the design.

Moment redistribution factor,  $q$ , based on the ACI Code 318-02 is calculated as follows:

$$q = 20 \left( 1 - \frac{\rho - \rho'}{\rho_b} \right) \quad (16.25)$$

where

$$\rho = \frac{A_s}{bd} \quad \rho' = \frac{A'_s}{bd} \quad \rho_b = 0.85 \quad \beta_1 \frac{f'_c}{f_y} \left( \frac{87}{87 + f_y} \right)$$

In Eq. 16.25, the code limits the steel ratio  $\rho$  or  $\rho - \rho'$  at the section where the moment is reduced to a maximum ratio of  $0.5\rho_b$ . The minimum steel ratio allowed in the section, for flexural design is  $\rho_{\min} = 3\sqrt{f'_c}/f_y \geq 200/f_y$ . Using these extreme limitations, the maximum and minimum moment redistribution percentages are shown in Table 16.3.

**Table 16.3** Maximum and Minimum Moment Redistribution  $q$  (Eq. [eqnid])

$f'_c$ (ksi)	$f_y$ (ksi)	$\rho_b$	$\rho_{\min}$	$q_{\max}$ % (for $\rho_{\min}$ )	$q_{\min}$ % (for $0.5 \rho_b$ )
3	60	0.0215	0.0033	16.9	10
4	60	0.0285	0.0033	17.7	10
5	60	0.339	0.0035	17.9	10

**Example 16.8**

Determine the maximum elastic moments at the supports and midspans of the continuous beam of four equal spans shown in Fig. 16.32a. The beam has a uniform section and carries a uniform dead load of 8 K/ft and a live load of 6 K/ft. Assume 10% maximum redistribution of moments and consider the following two cases: (1) When the live load is placed on alternate spans, calculate the maximum positive moments within the spans, and (2) when the live load is placed on adjacent spans, calculate the maximum negative moments at the supports.

**Solution**

- The beam has a uniform moment of inertia  $I$  and has the same  $E$ ; thus,  $EI$  is constant. The three-moment equation to analyze the beam and for a constant  $EI$  is

$$M_A L_1 + 2M_b(L_1 + L_2) + M_c L_2 = -\frac{w_1 L_1^3}{4} - \frac{w_2 L_2^3}{4}$$

Because the spans are equal,

$$M_A + 4M_B + M_C = -\frac{L^2}{4}(w_1 + w_2) \quad (16.26)$$

In this example  $M_A = M_E = 0$ . Six different cases of loading will be considered, as shown in Fig. 16.31:

**Case 1.** Dead load is placed on the whole beam  $ABCDE$  (Fig. 16.32b).

**Case 2.** Live load is placed on  $AB$  and  $CD$  for maximum positive moments within  $AB$  and  $CD$  (Fig. 16.32c).

**Case 3.** Similar to Case 2 for beams  $BC$  and  $DE$  (Fig. 16.32d).

**Case 4.** Live load is placed on  $AB$ ,  $BC$ , and  $DE$  for a maximum negative moment at  $B$  (Fig. 16.32e).

**Case 5.** Live load is placed on spans  $CD$  and  $DE$  (Fig. 16.32f).

**Case 6.** Live load is placed on  $BC$  and  $CD$  for a maximum negative moment at  $C$  (Fig. 16.32g).

- Case 1. Apply Eq. 16.26 to the beam segments  $ABC$ ,  $BCD$ , and  $CDE$ , respectively:

$$4M_B + M_C = -\frac{(20)^2}{4}(8 + 8) = -1600 \text{ K} \cdot \text{ft}$$

$$M_B + 4M_C + M_D = -1600 \text{ K} \cdot \text{ft}$$

$$M_C + 4M_D = -1600 \text{ K} \cdot \text{ft}$$

Solve the three equations to get

$$M_B = M_D = -342.8 \text{ K} \cdot \text{ft} \quad \text{and} \quad M_C = -228.6 \text{ K} \cdot \text{ft}$$

For a 10% reduction in moments,

$$M'_B = M'_D = 0.9(-342.8) = -308.5 \text{ K} \cdot \text{ft}$$

$$M'_C = 0.9(-228.6) = -205.7 \text{ K} \cdot \text{ft}$$

The corresponding midspan moments are

$$\text{Span } AB = DE = \frac{w_D L^2}{8} + \frac{1}{2} M_B = \frac{8(20)^2}{8} - \frac{1}{2} \times 308.5 = 245.8 \text{ K} \cdot \text{ft}$$

$$\text{Span } BC = CD = \frac{w_D L^2}{8} - \frac{1}{2} (308.5 + 205.7) = \frac{8(20)^2}{8} - 257.1 = 142.9 \text{ K} \cdot \text{ft}$$

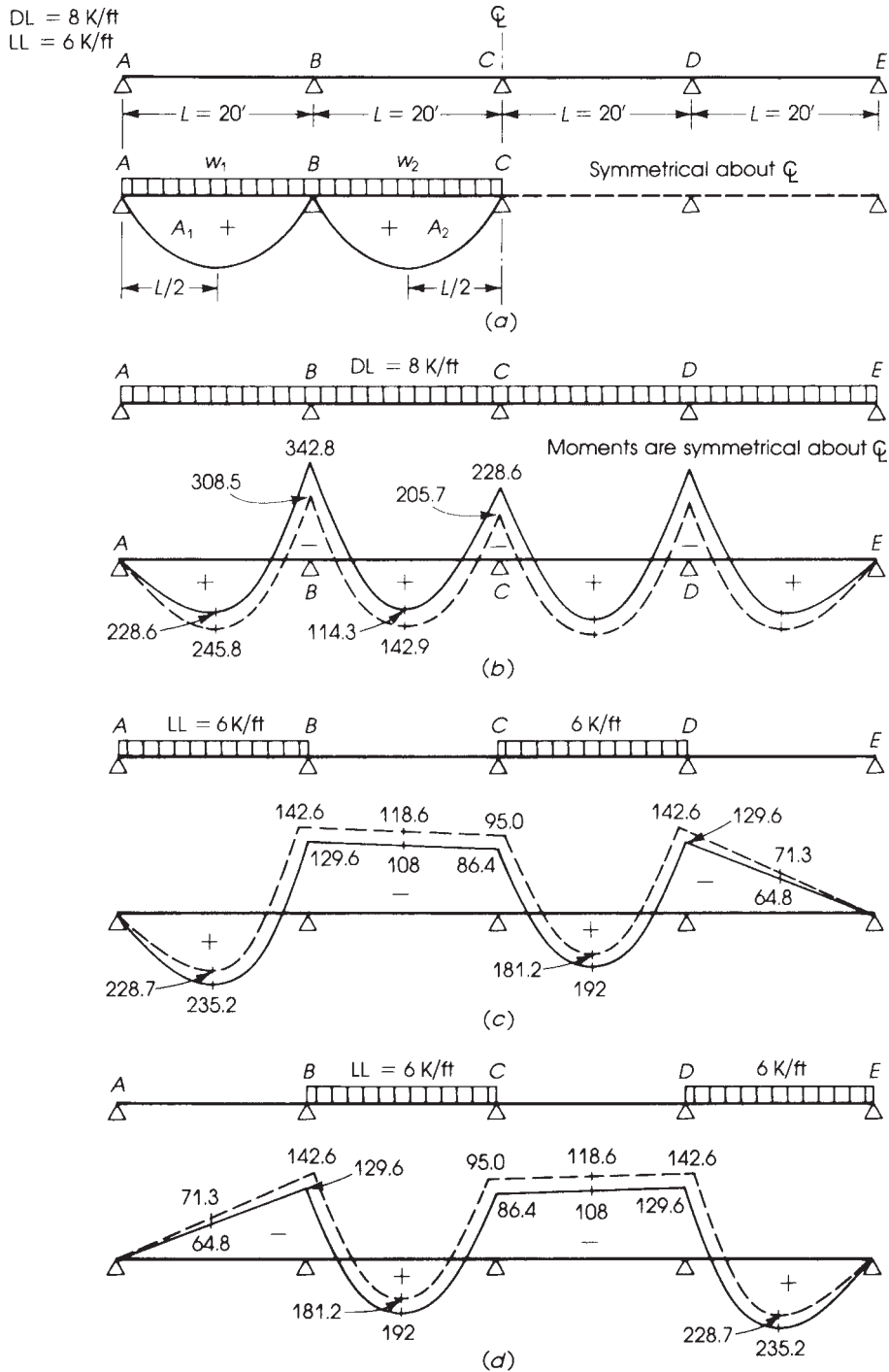


Figure 16.32 Example 16.8: Bending moments are drawn on the tension side.

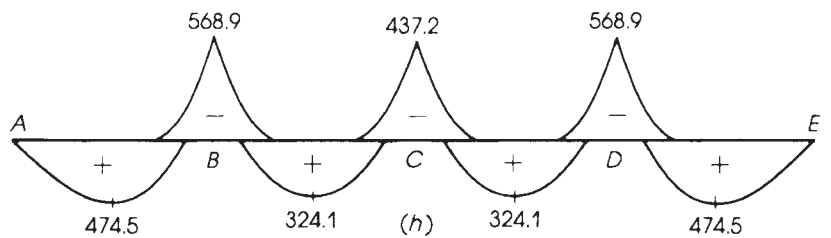
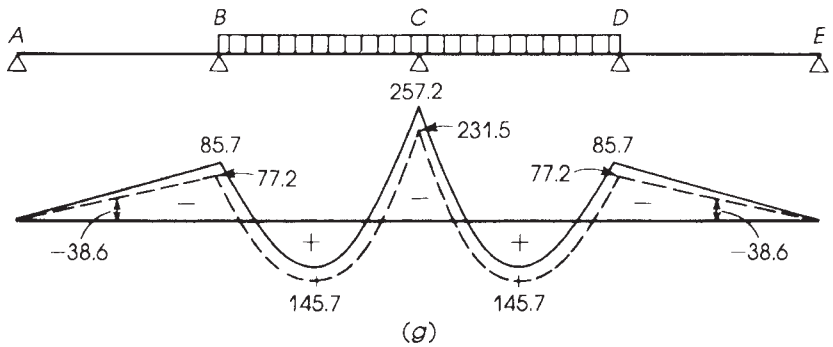
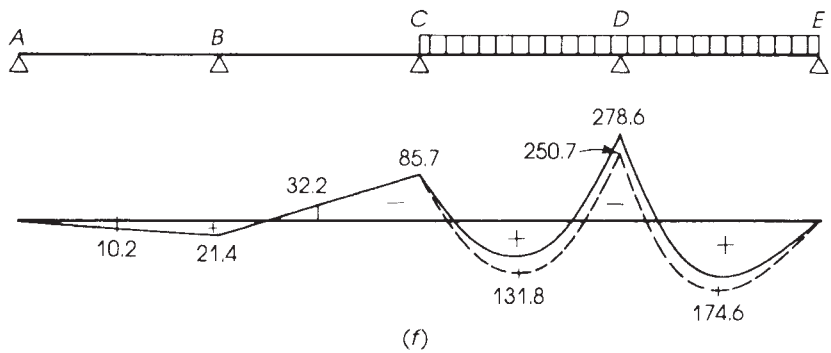
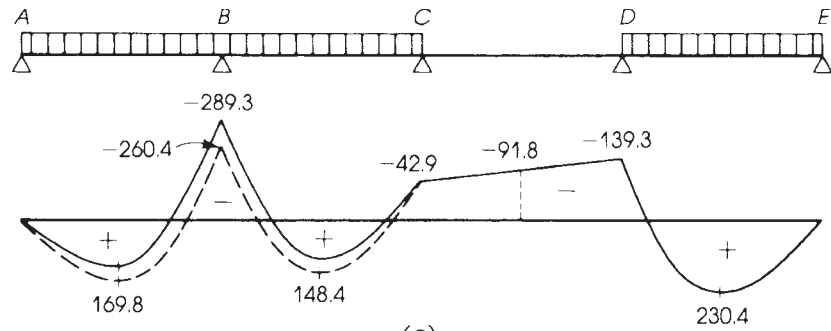


Figure 16.32 (continued)

3. Case 2. Apply Eq. 16.26 to  $ABC$ ,  $BCD$ , and  $CDE$ , respectively:

$$4M_B + M_C = -\frac{(20)^2}{4}(6) = -600 \text{ K} \cdot \text{ft}$$

$$M_B + 4M_C + M_D = -600 \text{ K} \cdot \text{ft}$$

$$M_C + 4M_D = -600 \text{ K} \cdot \text{ft}$$

Solve the three equations to get

$$M_B = M_D = -129.6 \text{ K} \cdot \text{ft} \quad M_C = -86.4 \text{ K} \cdot \text{ft}$$

The corresponding elastic midspan moments are

$$\text{Beam } AB = \frac{w_L L^2}{8} + \frac{M_B}{2} = \frac{6(20)^2}{8} - \frac{129.6}{2} = +235.2 \text{ K} \cdot \text{ft}$$

$$BC = 0 - \frac{1}{2}(129.6 + 86.4) = -108 \text{ K} \cdot \text{ft}$$

$$CD = \frac{w_L L^2}{8} - \frac{1}{2}(129.6 + 86.4) = \frac{6(20)^2}{8} - 108 = +192 \text{ K} \cdot \text{ft}$$

$$DE = 0 - \frac{1}{2} \times 129.6 = -64.8 \text{ K} \cdot \text{ft}$$

To reduce the positive span moment, increase the support moments by 10% and calculate the corresponding positive span moments. The resulting positive moment must be at least 90% of the first calculated moments given previously.

$$M'_B = M'_D = 1.1(-129.6) = -142.6 \text{ K} \cdot \text{ft}$$

$$M'_C = 1.1(-86.4) = -95.0 \text{ K} \cdot \text{ft}$$

The corresponding midspan moments are

$$\text{Beam } AB = \frac{w_L L^2}{8} + \frac{M'_B}{2} = \frac{6(20)^2}{8} - \frac{142.6}{2} = +228.7 \text{ K} \cdot \text{ft}$$

$$BC = -\frac{1}{2}(142.6 + 95) = -118.8 \text{ K} \cdot \text{ft}$$

$$CD = \frac{w_L L^2}{8} + \frac{1}{2}(M'_C + M'_D) = \frac{6(20)^2}{8} - \frac{1}{2}(95 + 142.6) = 181.2 \text{ K} \cdot \text{ft}$$

$$DE = -\frac{1}{2} \times 142.6 = -71.3 \text{ K} \cdot \text{ft}$$

4. Case 3. This case is similar to Case 2, and the moments are shown in Fig. 16.32d.  
 5. Case 4. Consider the spans  $AB$ ,  $BC$ , and  $DE$  loaded with live load to determine the maximum negative moment at support  $B$ :

$$4M_B + M_C = -\frac{w_L L^2}{2} = -\frac{6(20)^2}{2} = -1200 \text{ K} \cdot \text{ft}$$

$$M_B + 4M_C + M_D = -\frac{w_L L^2}{4} = -\frac{6(20)^2}{4} = -600 \text{ K} \cdot \text{ft}$$

$$M_C + 4M_D = -\frac{6(20)^2}{4} = -600 \text{ K} \cdot \text{ft}$$

Solve the three equations to get

$$M_C = -42.9 \text{ K} \cdot \text{ft}$$

$$M_B = -289.3 \text{ K} \cdot \text{ft}$$

$$M_D = -139.3 \text{ K} \cdot \text{ft}$$

For 10% reduction in moment at support  $B$ ,

$$M'_B = 0.9 \times (-289.3) = -260.4 \text{ K} \cdot \text{ft}$$

The corresponding midspan moments are

$$\text{Beam } AB = \frac{w_L L^2}{8} + \frac{M_B}{2} = \frac{6(20)^2}{8} - \frac{260.4}{2} = 169.8 \text{ K} \cdot \text{ft}$$

$$BC = \frac{w_L L^2}{8} - \frac{1}{2}(260.4 + 42.9) = 148.4 \text{ K} \cdot \text{ft}$$

$$CD = -\frac{1}{2}(42.9 + 139.3) = -91.1 \text{ K} \cdot \text{ft}$$

$$DE = 300 - \frac{1}{2} \times 139.3 = +230.4 \text{ K} \cdot \text{ft}$$

- 6.** Case 5. This is similar to Case 4, except that one end span is not loaded to produce maximum positive moment at support  $B$  (or support  $D$  for similar loading). The bending moment diagrams are shown in Fig. 16.32f.
- 7.** Case 6. Consider the spans  $BC$  and  $CD$  loaded with live load to determine the maximum negative moment at support  $C$ :

$$4M_B + M_C = \frac{w_L L^2}{4} = -600 \text{ K} \cdot \text{ft}$$

$$M_B + 4M_C + M_D = -\frac{w_L L^2}{2} = -1200 \text{ K} \cdot \text{ft}$$

$$M_C + 4M_D = -\frac{w_L L^2}{4} = -600 \text{ K} \cdot \text{ft}$$

Solve the three equations to get

$$M_C = -257.2 \text{ K} \cdot \text{ft}$$

$$M_B = M_D = -85.7 \text{ K} \cdot \text{ft}$$

For 10% reduction in support moments,

$$M'_C = 0.9 \times (-257.2) = -231.5 \text{ K} \cdot \text{ft}$$

$$M'_B = M'_C = 0.9 \times (-85.7) = -77.2 \text{ K} \cdot \text{ft}$$

The corresponding midspan moments are

$$\text{Beam } AB = DE = -\frac{77.2}{2} = -38.6 \text{ K} \cdot \text{ft}$$

$$BC = CD = \frac{w_L L^2}{8} - \frac{1}{2}(231.5 + 77.2) = \frac{6(20)^2}{8} - 154.3 = 145.7 \text{ K} \cdot \text{ft}$$

**Table 16.4** Final Moments of Example 16.8 after Moment Redistribution

Section Location	Case 1	Case 2	Case 3	Case 4	Case 5
	DL Moments	LL Maximum Negative	LL Maximum Positive	DL + LL (1) + (2) Maximum Negative	DL + LL (1) + (3) Maximum Positive
<b>Support</b>					
A	0	0	0	0	0
B	-308.5	-260.4	+21.4	-568.9 <sup>a</sup>	-287.1
C	-205.7	-231.5	—	-437.2 <sup>a</sup>	-205.7
D	-308.5	-260.4	+21.4	-568.9 <sup>a</sup>	-287.1
E	0	0	0	0	0
<b>Midspan</b>					
AB	245.8	-71.3	228.7	±174.5	±474.5 <sup>a</sup>
BC	142.9	-118.6	181.2	±24.3	±324.1 <sup>a</sup>
CD	142.9	-118.6	181.2	±24.3	±324.1 <sup>a</sup>
DE	245.8	-71.3	228.7	±174.5	±474.5 <sup>a</sup>

<sup>a</sup>Final maximum and minimum design moments.

- The final maximum and minimum moments after moment redistribution are shown in Table 16.4. The moment envelope is shown in Fig. 16.32*h*.
- In this example, the midspan sections are used for simplicity: The midspan moments are not necessarily the maximum positive moments. In the case of the end spans *AB* and *DE*, the maximum moment after 10% moment redistribution is equal to  $(w_D L_2)/12.2$  and occurs at  $0.4L$  from *A* and *D*.

### Example 16.9

Use the ACI Code limitation, determine the permissible redistribution of negative moments at supports *B*, *C*, *D*, and *E* of the continuous beam *ABCDEF* shown in Fig. 16.33. The beam has a rectangular section,  $b = 12$  in.,  $h = 22$  in., and  $d = 19.5$  in., and it is reinforced as shown in the following table ( $f'_c = 4$  ksi and  $f_y = 60$  ksi).

### Solution

- For  $f'_c = 4$  ksi and  $f_y = 60$  ksi,  $\rho_b = 0.0285$ . The ACI Code redistribution factor was given as follows:

$$q = 20 \left( 1 - \frac{\rho - \rho'}{\rho_b} \right) \quad (\text{Eq. 16.25})$$

- The ACI Code redistribution factor is a function of the net tensile strain,  $\epsilon_t$ , and varies between 7.5 and 20%, as shown in Fig. 16.31.

$$q' = 1000\epsilon_t$$

$$\epsilon_t = \frac{0.003 + f_y/E_s}{\rho/\rho_b} - 0.003$$



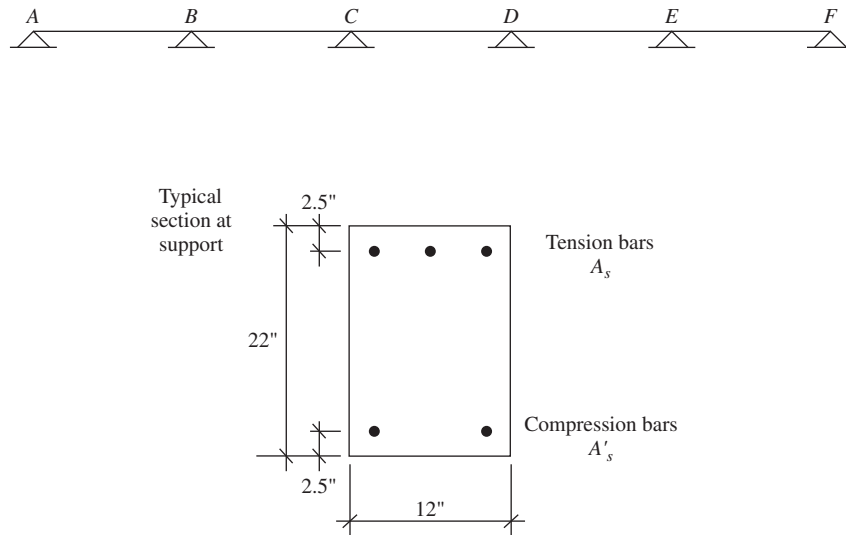


Figure 16.33 Example 16.9.

and

$$\epsilon_t = \frac{0.005}{\rho/\rho_b} - 0.003 \quad (\text{for } f_y = 60 \text{ ksi})$$

The following table shows the values of  $q$  and  $q'$ , which are not compatible.

Support	Tension Bars ( $A_s$ )	$\rho$	Compression Bars ( $A'_s$ )	$\rho'$	$\frac{\rho - \rho'}{\rho_b}$	$q\%$	$\epsilon_t$	$q'$
B	3 no. 9	0.01282	0	0	0.45	11.0	0.0113	11.3
C	3 no. 10	0.0160	0	0	0.56	8.8	0.006	0
D	3 no. 6	0.00564	0	0	0.198	16.0	0.0226	20
E	4 no. 8	0.01342	3 no. 6	0.0056	0.273	14.5	0.0153	15.3

## SUMMARY

### Sections 16.1–16.3

In continuous beams, the maximum and minimum moments are obtained by considering the dead load acting on all spans, whereas pattern loading is considered for live or moving loads, as shown in Figs. 16.2 and 16.3. The ACI moment coefficients described in Chapter 9 may be used to compute approximate values for the maximum and minimum moments and shears.

### Sections 16.4 and 16.5

A frame subjected to a system of loads may be analyzed by the equivalent frame method. Frames may be statically determinate or indeterminate.

### Section 16.6

There are several types of frame hinges: Mesnager, Considère, lead, and concrete hinges. The steel for a Mesnager hinge is calculated as follows:

$$A_{s_1} = \frac{R_1}{0.55f_y} \quad \text{and} \quad A_{s_2} = \frac{R_2}{0.55f_y} \quad (\text{Eq. 16.2})$$

$$\text{Burst force: } F = \frac{P_u}{2} \tan \theta + \frac{Ha}{0.85d} \quad (\text{Eq. 16.4})$$

$$\text{Stress in ties: } f_s = \frac{F}{0.005ab + A_{st}(\text{ties})} \leq 0.85f_y \quad (\text{Eq. 16.6})$$

### Sections 16.7 and 16.8

Limit design in reinforced concrete refers to redistribution of moments, which occurs throughout the structure as steel reinforcement reaches its yield strength. Ultimate strength is reached when the structure is on the verge of collapse. This case occurs when a number of plastic hinges,  $n$ , develop in a structure with redundants,  $r$ , such that  $n = 1 + r$ .

### Sections 16.9–16.11

For limit design to be valid, four conditions must be satisfied: mechanism, equilibrium, yield, and rotation. Two methods of analysis may be used: the virtual work method and the equilibrium method, which are both explained in Examples 16.3 through 16.6.

### Sections 16.12 and 16.13

The plastic hinge length,  $l_p$ , can be considered equal to the effective depth,  $d$ . In fibrous concrete,

$$l_p = (1.06 + 0.13\rho\rho_s)d$$

$$\text{Ductility index } \mu = \frac{\phi_u}{\phi_y} \quad (\text{Eq. 16.13})$$

For fibrous concrete,

$$\mu' = (1.0 + 3.8\rho_s)\mu \quad (\text{Eq. 16.15})$$

$$\text{Angle of rotation } \theta = \frac{0.0035}{\lambda} - \frac{f_y}{E_s(1 - \lambda)} \quad (\text{Eq. 16.18})$$

$$\lambda = \frac{\rho f_y}{0.72f'_c} \leq 0.5 \quad (\text{Eq. 16.19})$$

A summary of the limit design procedure is given in Section 16.14.

### Section 16.14

Moment redistribution may be taken into account in the analysis of statically indeterminate structures. In this case, the maximum negative moments calculated by the elastic theory may be increased or decreased by not more than the ratio  $q'$ , where

$$q' = 1000\varepsilon_t \quad (\text{Eq. 16.24})$$

Table 16.1 gives the different values of  $q$ . Moment redistribution is explained in detail in Example 6.8.

## REFERENCES

1. J. C. McCormac. *Structural Analysis*. Intext, New York, 1985.
2. M. N. Hassoun. *Ultimate Load Design of Reinforced Concrete*. Cement and Concrete Association, London, 1981.
3. A. L. L. Baker. *The Ultimate Load Theory Applied to the Design of Reinforced and Prestressed Concrete Frames*. Concrete Publications, London, 1956.
4. W. Prager and P. G. Hodge. *Theory of Perfectly Plastic Solids*. Wiley, New York, 1951.
5. L. S. Beedle, B. Thürlimann, and R. L. Ketter. *Plastic Design in Structural Steel*. American Institute of Steel Construction, New York, 1955.
6. J. F. Baker, M. R. Horne, and J. Heyman. *The Steel Skeleton*, vol. 2. Cambridge University Press, London, 1956.
7. A. L. L. Baker. *Limit-State Design of Reinforced Concrete*. Cement and Concrete Association, London, 1970.
8. W. B. Cranston. *Tests on Reinforced Concrete Portal Frames*. Technical Report TRA-392. Cement and Concrete Association, London, 1965.
9. B. G. Neal. *The Plastic Methods of Structural Analysis*. Chapman and Hall, London, 1956.
10. L. S. Bedle. *Plastic Design of Steel Frames*. Wiley, New York, 1958.
11. M. R. Horne. *Plastic Theory of Structures*. MIT Press, Cambridge, MA, 1971, pp. 16–17.
12. W. G. Corley. “Rotational Capacity of Reinforced Concrete Beams.” *ASCE Journal, Structural Division* 92 (October 1966).
13. A. H. Mattock. “Discussion.” *ASCE Journal, Structural Division* 93 (April 1967).
14. K. Sahebjam. *The Effect of Steel Fibers on the Plastic Rotation of Reinforced Concrete Continuous Beams*. MS Thesis. South Dakota State University, Brookings 1984.
15. W. Chan. “The Ultimate Strength and Deformation of Plastic Hinges in Reinforced Concrete Frameworks.” *Magazine of Concrete Research* (November 1955).
16. S. K. Kaushik, L. M. Ramamurthy, and C. B. Kukreja. “Plasticity in Reinforced Concrete Continuous Beams, with Parabolic Soffits.” *ACI Journal* (September–October 1980).
17. R. W. Furlong. “Design of Concrete Frames by Assigned Moment Limits.” *ACI Journal* 67 (April 1970).
18. P. G. Hodge. *Plastic Analysis of Structures*. McGraw-Hill, New York, 1959.
19. M. Hilal. *Design of Reinforced Concrete Halls*. J. Marcou and Company, Cairo, 1971.
20. V. Ramakrishnan and P. D. Arthur. *Ultimate Strength Design for Structural Concrete*. Wheeler Publishing, Allahabad, India, 1982.
21. R.C. Reese, J. G. MacGregor, I. Lyse, Council on Tall Buildings and Urban Habitat, et al. *Structural Design of Tall Concrete and Masonry Buildings*. American Society of Civil Engineers, New York, 1978.
22. American Concrete Institute (ACI). *Building Code Requirements for Structural Concrete*. ACI Code 318-14. ACI, Detroit, MI 2014.

## PROBLEMS

- 16.1 The slab–beam floor system shown in Fig. 16.34 carries a uniformly distributed dead load (excluding weight of slab and beam) of 40 psf and a live load of 100 psf. Using the ACI Code coefficients, design the interior continuous beam  $ABCD$  and draw detailed sections. Given:  $f'_c = 4$  ksi,  $f_y = 40$  ksi, width of beam web = 12 in., slab thickness = 4.0 in., and column dimensions = 14 by 14 in.

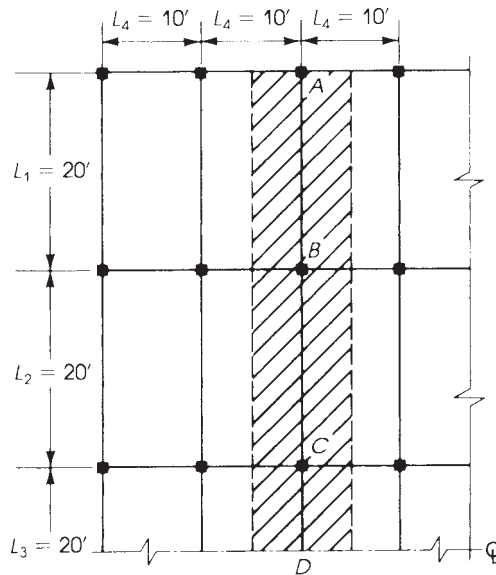


Figure 16.34 Problem 16.1.

16.2 Repeat Problem 16.1 using span lengths of the beams shown in Fig. 16.32 as follows:

$$\begin{aligned} L_1 &= 20 \text{ ft} & L_2 &= 24 \text{ ft} \\ L_3 &= 20 \text{ ft} & L_4 &= 10 \text{ ft} \end{aligned}$$

16.3 For the beam shown in Fig. 16.35, compute the reactions at  $A$ ,  $B$ , and  $C$  using constant  $EI$ . Draw the shear and bending moment diagrams and design all critical sections, using  $b = 14$  in.,  $h = 25$  in.,  $f'_c = 4$  ksi,  $f_y = 40$  ksi, and a load factor = 1.6.

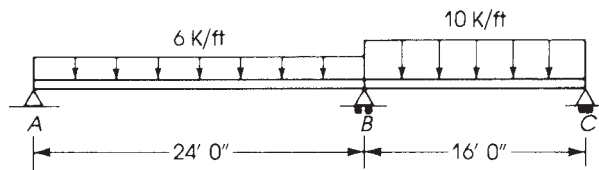


Figure 16.35 Problem 16.3.

16.4 Repeat Problem 16.3 using span lengths of beams as follows: span  $AB = 20$  ft and span  $BC = 16$  ft.

16.5 The two-hinged portal frame  $ABCD$  shown in Fig. 16.36 carries a uniform dead load (excluding self-weight) = 2.6 K/ft and a uniform live load of 1.8 K/ft. Design the frame  $ABCD$ , the hinges, and footings using  $f'_c = 4$  ksi,  $f_y = 40$  ksi, and a beam width of  $b = 16$  in. The footing is placed 5 ft below ground level and the allowable bearing soil pressure is 5 ksf. Use a slab thickness of 6 in.

16.6 Design the portal frame  $ABCD$  of Problem 16.5 if the frame ends at  $A$  and  $D$  are fixed.

16.7 Calculate the collapse moments at the critical sections of the beams shown in Fig. 16.37.

16.8 Repeat Problem 16.7 for Fig. 16.38.

16.9 If the beam shown in Fig. 16.36 carries a uniform dead load of 2.5 K/ft and a live load of 2.4 K/ft, design the beam using the limit design procedure. Use  $f'_c = 4$  ksi,  $f_y = 40$  ksi, and a beam width of  $b = 14$  in.

DL = 2 K/ft  
LL = 1.8 K/ft

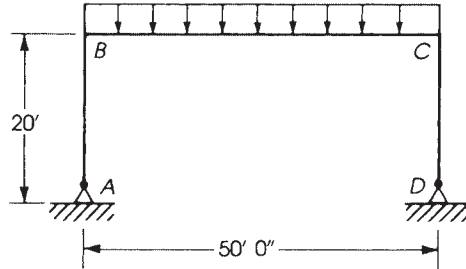


Figure 16.36 Problem 16.5.

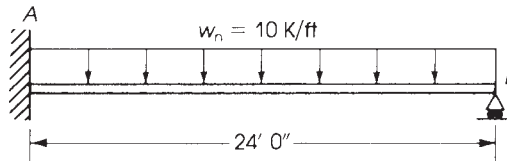


Figure 16.37 Problem 16.7.

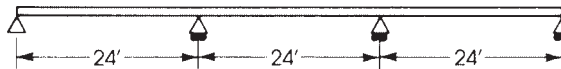


Figure 16.38 Problem 16.8.

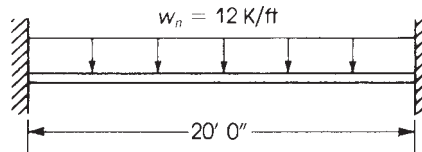


Figure 16.39 Problem 16.11.

- 16.10** Determine the maximum and minimum elastic moments at the supports and midspans of the three-span continuous beam shown in Fig. 16.37. The beam has a uniform rectangular section and carries a uniform dead load of 6 K/ft and a live load of 5 K/ft. Assuming 10% maximum redistribution of moments; recalculate the maximum and minimum moments at the supports and midspans of the beam ABC. *Note:* Place the live load on alternate spans to calculate maximum positive moments and on adjacent spans to calculate the maximum negative (minimum) moments (Example 16.8).
- 16.11** Repeat Problem 16.10 if the beam consists of four equal spans, each 24 ft in length (Fig. 16.39).

# CHAPTER 17

## DESIGN OF TWO-WAY SLABS



The Bonaventure Complex and the Bonaventure Hilton Hotel, Montreal, Canada.

### 17.1 INTRODUCTION

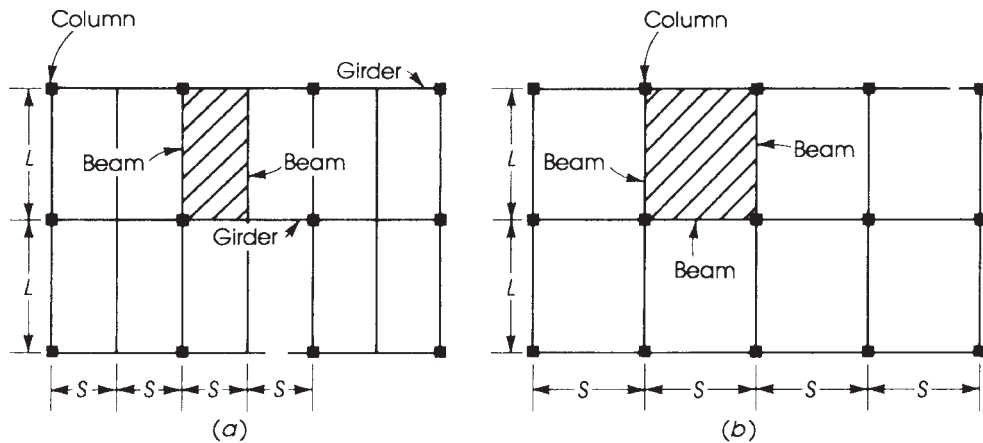
Slabs can be considered as structural members whose depth,  $h$ , is small as compared to their length,  $L$ , and width,  $S$ . The simplest form of a slab is one supported on two opposite sides, which primarily deflects in one direction and is referred to as a *one-way slab*. The design of one-way slabs was discussed in Chapter 9.

When the slab is supported on all four sides and the length,  $L$ , is less than twice the width,  $S$ , the slab will deflect in two directions, and the loads on the slab are transferred to all four supports. This slab is referred to as a *two-way slab*. The bending moments and deflections in such slabs are less than those in one-way slabs; thus, the same slab can carry more loads when supported on four sides. The load in this case is carried in two directions, and the bending moment in each direction is much less than the bending moment in the slab if the load were carried in one direction only. Typical slab-beam-girder arrangements of one-way and two-way slabs are shown in Fig. 17.1.

### 17.2 TYPES OF TWO-WAY SLABS

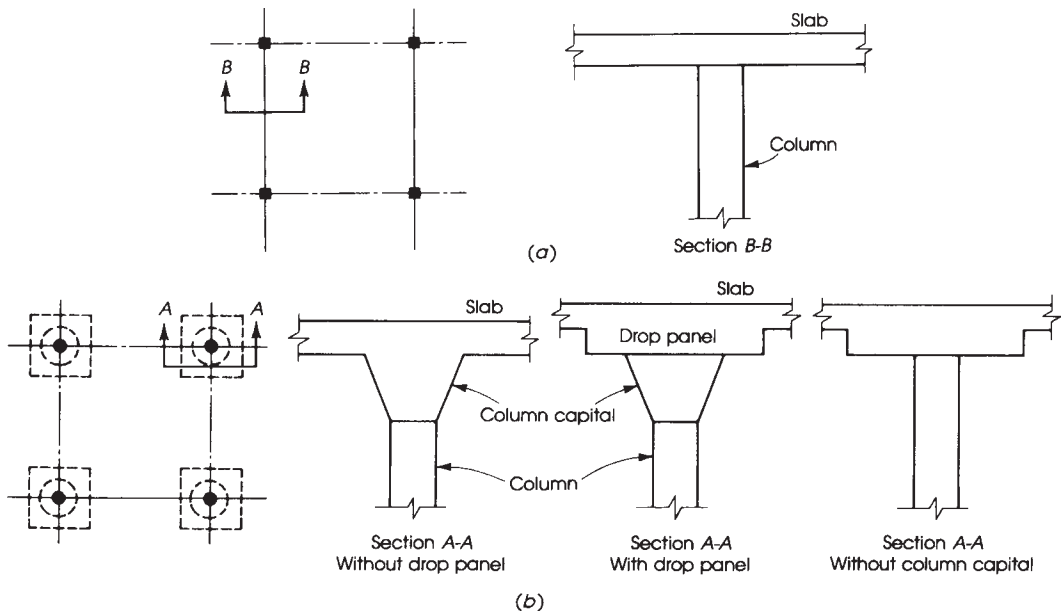
Structural two-way concrete slabs may be classified as follows:

1. *Two-way slabs on beams*: This case occurs when the two-way slab is supported by beams on all four sides (Fig. 17.1). The loads from the slab are transferred to all four supporting beams, which, in turn, transfer the loads to the columns.
2. *Flat slabs*: A flat slab is a two-way slab reinforced in two directions that usually does not have beams or girders, and the loads are transferred directly to the supporting columns. The column tends to punch through the slab, which can be treated by three methods (refer to 17.2 and 17.3):
  - a. Using a drop panel and a column capital.
  - b. Using a drop panel without a column capital. The concrete panel around the column capital should be thick enough to withstand the diagonal tensile stresses arising from the punching shear.
  - c. Using a column capital without drop panel, which is not common.

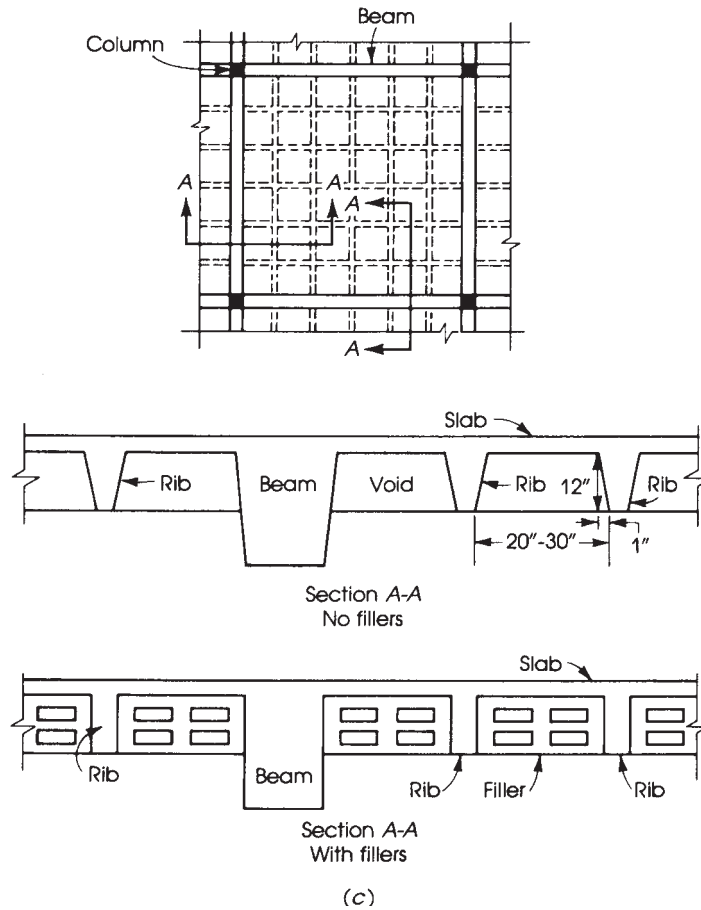


**Figure 17.1** (a) One-way slab,  $L/S > 2$ , and (b) two-way slab,  $L/S \leq 2$ .

3. *Flat-plate floors*: A flat-plate floor is a two-way slab system consisting of a uniform slab that rests directly on columns and does not have beams or column capitals (Fig. 17.2a). In this case the column tends to punch through the slab, producing diagonal tensile stresses. Therefore, a general increase in the slab thickness is required or special reinforcement is used.
4. *Two-way ribbed slabs and the waffle slab system*: This type of slab consists of a floor slab with a length-to-width ratio less than 2. The thickness of the slab is usually 2 to 4 in. and is supported by ribs (or joists) in two directions. The ribs are arranged in each direction at



**Figure 17.2** Two-way slabs without beams: (a) flat-plate floor and section, (b) flat-slab floor and sections, and (c) ribbed slab and sections.

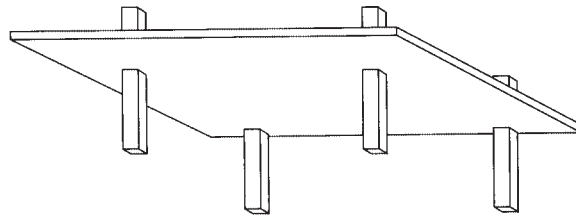


**Figure 17.2** (continued)

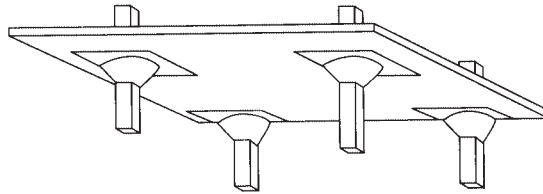
spacings of about 20 to 30 in., producing square or rectangular shapes (Fig. 17.2c). The ribs can also be arranged at  $45^\circ$  or  $60^\circ$  from the centerline of slabs, producing architectural shapes at the soffit of the slab. In two-way ribbed slabs, different systems can be adopted:

- a. A two-way rib system with voids between the ribs, obtained by using special removable and usable forms (pans) that are normally square in shape. The ribs are supported on four sides by girders that rest on columns. This type is called a *two-way ribbed (joist) slab system*.
- b. A two-way rib system with permanent fillers between ribs that produce horizontal slab soffits. The fillers may be of hollow, lightweight, or normal-weight concrete or any other lightweight material. The ribs are supported by girders on four sides, which in turn are supported by columns. This type is also called a *two-way ribbed (joist) slab system* or a *hollow-block two-way ribbed system*.
- c. A two-way rib system with voids between the ribs with the ribs continuing in both directions without supporting beams and resting directly on columns through solid panels above the columns. This type is called a *waffle slab system*.

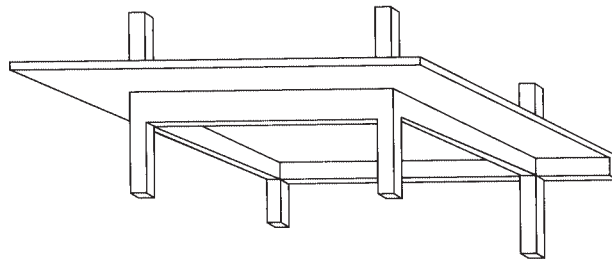




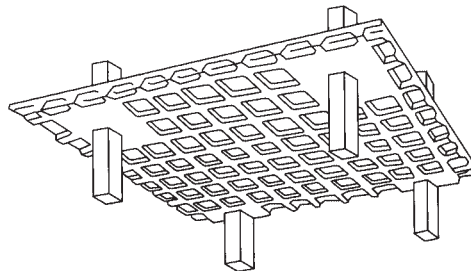
(a)



(b)



(c)



(d)

**Figure 17.3** Types of two-way slab systems: (a) flat plate, (b) flat slab, (c) slab on beams, and (d) waffle slab.

### 17.3 ECONOMICAL CHOICE OF CONCRETE FLOOR SYSTEMS

Various types of floor systems can be used for general buildings, such as residential, office, and institutional buildings. The choice of an adequate and economic floor system depends on the type of building, architectural layout, aesthetic features, and the span length between columns. In general, the superimposed live load on buildings varies between 80 and 150 psf. A general guide for the economical use of floor systems can be summarized as follows:

1. *Flat plates:* Flat plates are most suitable for spans of 20 to 25 ft and live loads between 60 and 100 psf. The advantages of adopting flat plates include low-cost formwork, exposed flat ceilings, and fast construction. Flat plates have low shear capacity and relatively low stiffness, which may cause noticeable deflection. Flat plates are widely used in buildings either as reinforced or prestressed concrete slabs.
2. *Flat slabs:* Flat slabs are most suitable for spans of 20 to 30 ft and for live loads of 80 to 150 psf. They need more formwork than flat plates, especially for column capitals. In most cases, only drop panels without column capitals are used.
3. *Waffle slabs:* Waffle slabs are suitable for spans of 30 to 48 ft and live loads of 80 to 150 psf. They carry heavier loads than flat plates and have attractive exposed ceilings. Formwork, including the use of pans, is quite expensive.
4. *Slabs on beams:* Slabs on beams are suitable for spans between 20 and 30 ft and live loads of 60 to 120 psf. The beams increase the stiffness of the slabs, producing relatively low deflection. Additional formwork for the beams is needed.



Flat-plate floor system.



Slab on beams.

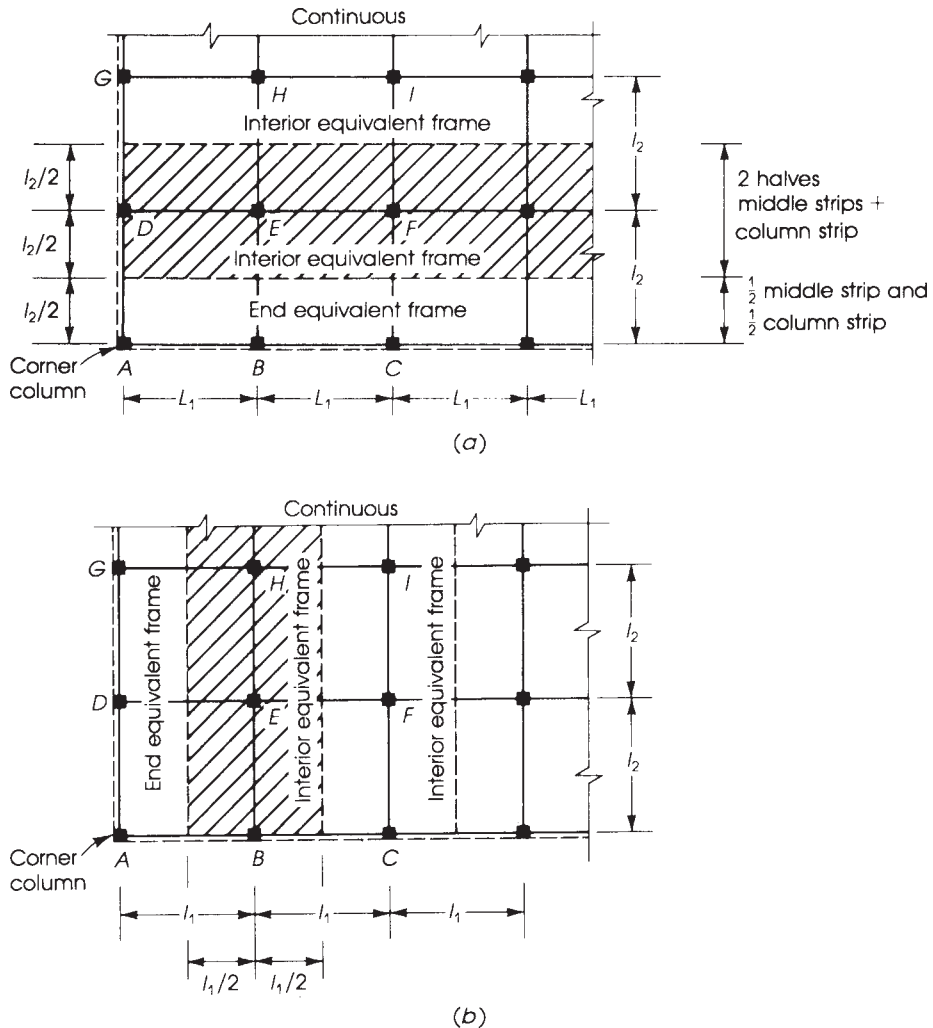
5. *One-way slabs on beams:* One-way slabs on beams are most suitable for spans of 10 to 20 ft and a live load of 60 to 100 psf. They can be used for larger spans with relatively higher cost and higher slab deflection. Additional formwork for the beams is needed.
6. *One-way joist floor system:* A one-way joist floor system is most suitable for spans of 20 to 30 ft and live loads of 80 to 120 psf. Because of the deep ribs, the concrete and steel quantities are relatively low, but expensive formwork is expected. The exposed ceiling of the slabs may look attractive.

## 17.4 DESIGN CONCEPTS

An exact analysis of forces and displacements in a two-way slab is complex, due to its highly indeterminate nature; this is true even when the effects of creep and nonlinear behavior of the concrete are neglected. Numerical methods such as finite elements can be used, but simplified methods such as those presented by the ACI Code are more suitable for practical design. The ACI Code, Chapter 8, assumes that the slabs behave as wide, shallow beams that form, with the columns above and below them, a rigid frame. The validity of this assumption of dividing the structure into equivalent frames has been verified by analytical [1, 2] and experimental [3, 4] research. It is also established [3, 5] that factored load capacity of two-way slabs with restrained boundaries is about twice that calculated by theoretical analysis because a great deal of moment redistribution occurs in the slab before failure. At high loads, large deformations and deflections are expected; thus, a minimum slab thickness is required to maintain adequate deflection and cracking conditions under service loads.

The ACI Code specifies two methods for the design of two-way slabs:

1. The direct design method, DDM (ACI Code, Section 8.10), is an approximate procedure for the analysis and design of two-way slabs. It is limited to slab systems subjected to uniformly distributed loads and supported on equally or nearly equally spaced columns. The method uses a set of coefficients to determine the design moments at critical sections. Two-way slab systems that do not meet the limitations of the ACI Code, Section 8.10.1.1, must be analyzed by more accurate procedures.
2. The equivalent frame method, EFM (ACI Code, Section 8.11), is one in which a three-dimensional building is divided into a series of two-dimensional equivalent frames by cutting the building along lines midway between columns. The resulting frames are considered separately in the longitudinal and transverse directions of the building and treated floor by floor, as shown in Fig. 17.4.



**Figure 17.4** (a) Longitudinal and (b) transverse equivalent frames in plan view and (c) in elevation and perspective views.

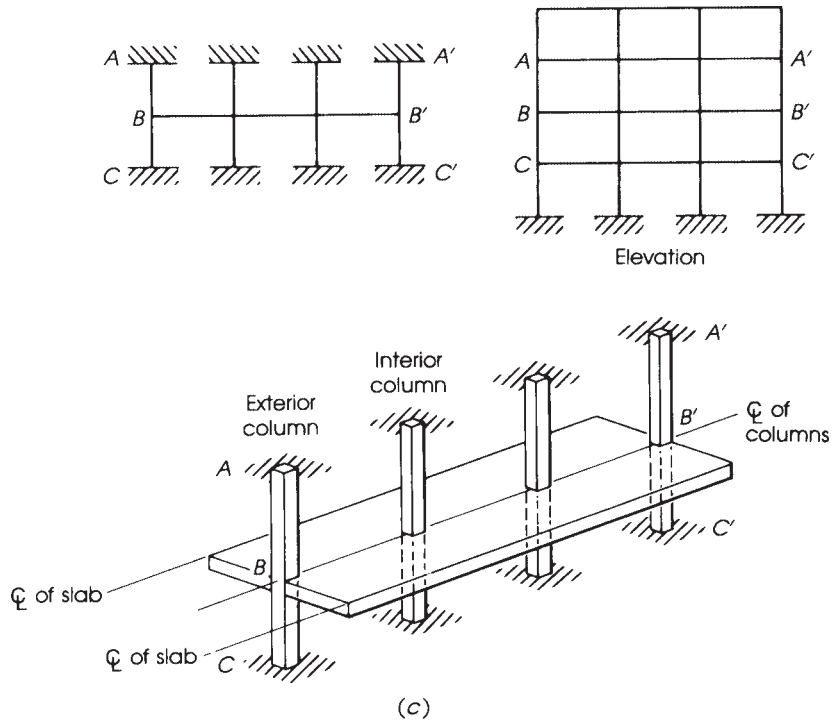


Figure 17.4 (continued)



Flat-slab system with drop panels (no column capitals).

Two ACI Code procedures are based on the results of elastic analysis of the structure as a whole using factored loads. A modified approach to the direct design method was presented in the commentary of the 1989 Code as the modified stiffness method, or MSM. It is based on specific distribution factors introduced as a function of the stiffness ratio,  $\alpha_{ec}$ , for proportioning the total static moment in an end span. This method is explained later.

In addition to the ACI Code procedures, a number of other alternatives are available for the analysis and design of slabs. The resulting slabs may have a greater or lesser amount of reinforcement. The analytical methods may be classified in terms of the basic relationship between load and deformation as elastic, plastic, and nonlinear.

1. In *elastic analysis*, a concrete slab may be treated as an elastic plate. The flexure, shear, and deflection may be calculated by the fourth differential equation relating load to deflection for thin plates with small displacements, as presented by Timoshenko and Krieger [6]. Finite difference as well as finite element solutions have been proposed to analyze slabs and plates [7, 8]. In the finite element method, the slab is divided into a mesh of triangles or quadrilaterals. The displacement functions of the nodes (intersecting mesh points) are usually established, and the stiffness matrices are developed for computer analysis.
2. For *plastic analysis*, three methods are available. The *yield line* method was developed by Johansen [9] to determine the limit state of the slab by considering the yield lines that occur in the slab as a collapse mechanism. The *strip* method was developed by Hillerborg [10]. The slab is divided into strips, and the load on the slab is distributed in two orthogonal directions. The strips are analyzed as simple beams. The third method is *optimal analysis*. There has been considerable research into optimal solutions. Dhir, and others Munday [11] presented methods for minimizing reinforcement based on plastic analysis. Optimal solutions are complex in analysis and produce complex patterns of reinforcement.
3. *Nonlinear analysis* simulates the true load deformation characteristics of a reinforced concrete slab when the finite element method takes into consideration the nonlinearity of the stress–strain relationship of the individual elements [11, 12]. In this case, the solution becomes complex unless simplified empirical relationships are assumed.

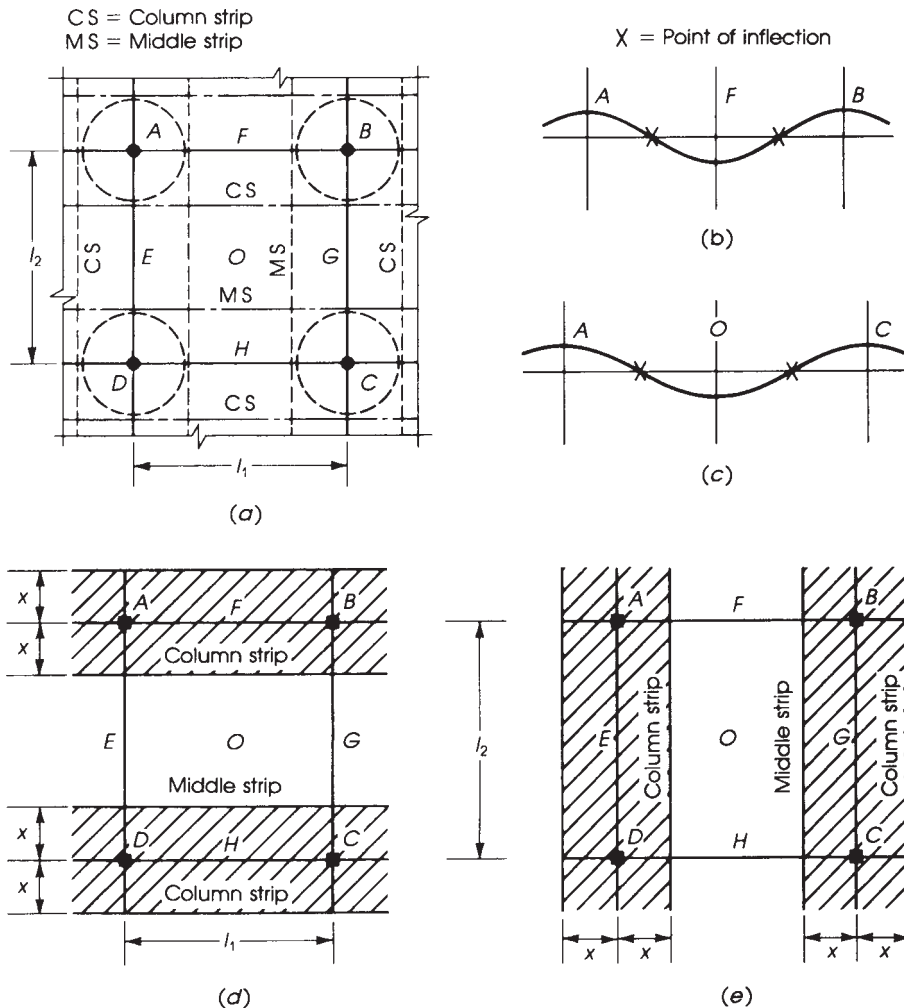


Waffle slab with light fixtures at the centers of the squares.

The preceding methods are presented very briefly to introduce the reader to the different methods of analysis of slabs. Experimental work on slabs has not been extensive in recent years, but more research is probably needed to simplify current design procedures with adequate safety, serviceability, and economy [11].

## 17.5 COLUMN AND MIDDLE STRIPS

Figure 17.5 shows an interior panel of a two-way slab supported on columns  $A$ ,  $B$ ,  $C$ , and  $D$ . If the panel is loaded uniformly, the slab will deflect in both directions, with maximum deflection at the center,  $O$ . The highest points will be at the columns  $A$ ,  $B$ ,  $C$ , and  $D$ ; thus, the part of the slab around the columns will have a convex shape. A gradual change in the shape of the slab occurs, from convexity at the columns to concavity at the center of the panel  $O$ , each radial line crossing a point of inflection. Sections at  $O$ ,  $E$ ,  $F$ ,  $G$ , and  $H$  will have positive bending moments, whereas the



**Figure 17.5** Column and middle strips;  $x = 0.25\ell_1$  or  $0.25\ell_2$ , whichever is smaller.

periphery of the columns will have maximum negative bending moments. Considering a strip along  $AFB$ , the strip bends like a continuous beam (Fig. 17.5*b*), having negative moments at  $A$  and  $B$  and positive bending moment at  $F$ . This strip extends between the two columns  $A$  and  $B$  and continues on both sides of the panel, forming a column strip.

Similarly, a strip along  $EOG$  will have negative bending moments at  $E$  and  $G$  and a positive moment at  $O$ , forming a middle strip. A third strip along  $DHC$  will behave similarly to strip  $AFB$ . Therefore, the panel can be divided into three strips, one in the middle along  $EOG$ , referred to as the *middle strip*, and one on each side, along  $AFB$  and  $DHC$ , referred to as *column strips* (Fig. 17.5*a*). Each of the three strips behaves as a continuous beam. In a similar way, the panel is divided into three strips in the other direction, one middle strip along  $FOH$  and two column strips along  $AED$  and  $BGC$ , respectively (Fig. 17.5*e*).

Referring to Fig. 17.5*a*, it can be seen that the middle strips are supported on the column strips, which in turn transfer the loads onto the columns,  $A$ ,  $B$ ,  $C$ , and  $D$  in this panel. Therefore, the column strips carry more load than the middle strips. Consequently, the positive bending moment in each column strip (at  $E$ ,  $F$ ,  $G$ , and  $H$ ) is greater than the positive bending moment at  $O$  in the middle strip. Also, the negative moments at the columns  $A$ ,  $B$ ,  $C$ , and  $D$  in the column strips are greater than the negative moments at  $E$ ,  $F$ ,  $G$ , and  $H$  in the middle strips. The portions of the design moments assigned to each critical section of the column and middle strips are discussed in Section 17.8.

The extent of each of the column and middle strips in a panel is defined by the ACI Code, Sections 8.4.1.5 and 8.4.1.6. The column strip is defined by a slab width on each side of the column centerline,  $x$  in Fig. 17.5, equal to one-fourth the smaller of the panel dimensions  $l_1$  and  $l_2$ , including beams if they are present, where

$l_1$  = span length, center to center of supports, in the direction moments are being determined

$l_2$  = span length, center to center of supports, in the direction perpendicular to  $l_1$

The portion of the panel between two column strips defines the middle strip.

## 17.6 MINIMUM SLAB THICKNESS TO CONTROL DEFLECTION

The ACI Code, Sections 8.3.1.1 and 8.3.1.2, specifies a minimum slab thickness in two-way slabs to control deflection. The magnitude of a slab's deflection depends on many variables, including the flexural stiffness of the slab, which in turn is a function of the slab thickness,  $h$ . By increasing the slab thickness, the flexural stiffness of the slab is increased, and consequently the slab deflection is reduced [13]. Because the calculation of deflections in two-way slabs is complicated and to avoid excessive deflections, the ACI Code limits the thickness of these slabs by adopting the following three empirical limitations, which are based on experimental research. If these limitations are not met, it will be necessary to compute deflections.

1. For  $0.2 < \alpha_{fm} \leq 2$ ,

$$h = \frac{l_n(0.8 + f_y/200,000)}{36 + 5\beta(\alpha_{fm} - 0.2)} \quad (f_y \text{ in psi}) \quad h = \frac{l_n(0.8 + f_y/1400)}{36 + 5\beta(\alpha_{fm} - 0.2)} \quad (f_y \text{ in MPa}) \quad (17.1)$$

but not less than 5 in.

2. For  $\alpha_{fm} > 2.0$ ,

$$h = \frac{l_n(0.8 + f_y/200,000)}{36 + 9\beta} \quad (f_y \text{ in psi}) \quad h = \frac{l_n(0.8 + f_y/1400)}{36 + 9\beta} \quad (f_y \text{ in MPa}) \quad (17.2)$$

but not less than 3.5 in.



3. For  $\alpha_{fm} \leq 0.2$ ,

$$h = \text{minimum slab thickness without interior beams (Table 17.1)} \quad (17.3)$$

where

$l_n$  = clear span in long direction measured face to face of columns (or face to face of beams for slabs with beams)

$\beta$  = ratio of the long to the short clear spans

$\alpha_{fm}$  = average value of  $\alpha$  for all beams on the sides of a panel

$\alpha_f$  = ratio of flexural stiffness of a beam section  $E_{cb}I_b$  to flexural stiffness of the slab  $E_{cs}I_s$ , bounded laterally by the centerlines of the panels on each side of the beam

$$\alpha_f = \frac{E_{cb}I_b}{E_{cs}I_s} \quad (17.4)$$

where

$E_{cb}, E_{cs}$  = moduli of elasticity of concrete in beam and slab, respectively

$I_b$  = gross moment of inertia of beam section about centroidal axis (beam section includes a slab length on each side of beam equal to projection of beam above or below slab, whichever is greater, but not more than four times slab thickness)

$I_s$  = moment of inertia of gross section of slab

However, the thickness of any slab shall not be less than the following:

1. For slabs with  $\alpha_{fm} \leq 2.0$  then thickness  $\geq 5.0$  in. (125 mm)
2. For slabs with  $\alpha_{fm} > 2.0$  then thickness  $\geq 3.5$  in. (90 mm)

If no beams are used, as in the case of flat plates, then  $\alpha_f = 0$  and  $\alpha_{fm} = 0$ . The ACI Code equations for calculating slab thickness,  $h$ , take into account the effect of the span length, the panel shape, the steel reinforcement yield stress,  $f_y$ , and the flexural stiffness of beams. When very stiff beams are used, Eq. 17.1 may give a small slab thickness, and Eq. 17.2 may control. For flat plates and flat slabs, when no interior beams are used, the minimum slab thickness may be determined directly from Table 8.3.1.1 of the ACI Code, which is shown here as Table 17.1.

**Table 17.1** Minimum Thickness of Slabs Without Interior Beams

Yield Stress $f_y$ , psi (1) <sup>b</sup>	Without Drop Panels <sup>a</sup>			With Drop Panels <sup>a</sup>		
	Exterior Panels		Interior Panels	Exterior Panels		
	Without Edge Beams	With Edge Beams		Without Edge Beams	With Edge Beams <sup>c</sup>	Interior Panels
40,000	$\frac{l_n}{33}$	$\frac{l_n}{36}$	$\frac{l_n}{36}$	$\frac{l_n}{36}$	$\frac{l_n}{40}$	$\frac{l_n}{40}$
60,000	$\frac{l_n}{30}$	$\frac{l_n}{33}$	$\frac{l_n}{33}$	$\frac{l_n}{33}$	$\frac{l_n}{36}$	$\frac{l_n}{36}$

<sup>a</sup>For values of reinforcement, yield stress between 40,000 and 60,000 psi minimum thickness shall be obtained by linear interpolation.

<sup>b</sup>Drop panel is defined in ACI Sections 13.3.7 and 13.2.5.

<sup>c</sup>Slabs with beams between columns along exterior edges. The value of  $\alpha_f$  for the edge beam shall be not less than 0.8.

Other ACI Code limitations are summarized as follows:

1. For panels with discontinuous edges, end beams with a minimum  $\alpha$  equal to 0.8 must be used; otherwise, the minimum slab thickness calculated by Eqs. 17.1 and Eqs. 17.2 must be increased by at least 10% (ACI Code, Section 8.3.1.2.1).
2. The drop panels should extend in each direction from the centerline of support a distance not less than one-sixth of the span length in that direction between center to center of supports and also project below the slab at least  $h/4$ .
3. Regardless of the values obtained by Eqs. 17.1 and 17.2, the thickness of two-way slabs shall not be less than the following (a) for slabs without interior beams or drop panels, 5 in. (125 mm) (ACI Code, Section 8.3.1.1); (b) for slabs without interior beams but with drop panels, 4 in. (100 mm) (ACI Code, Section 8.3.1.1); and (c) for slabs with beams on all four sides with  $\alpha_{fm} > 2.0$ ,  $3\frac{1}{2}$  in. (90 mm), and for  $\alpha_{fm} \leq 2.0$ , 5 in. (125 mm) (ACI Code, Section 8.3.1.2).

### Example 17.1

A flat-plate floor system with panels  $4 \times 20$  ft is supported on 20-in. square columns. Using the ACI Code equations, determine the minimum slab thickness required for the interior and corner panels shown in Fig. 17.6. Edge beams are not used. Use  $f'_c = 4$  ksi and  $f'_y = 60$  ksi.

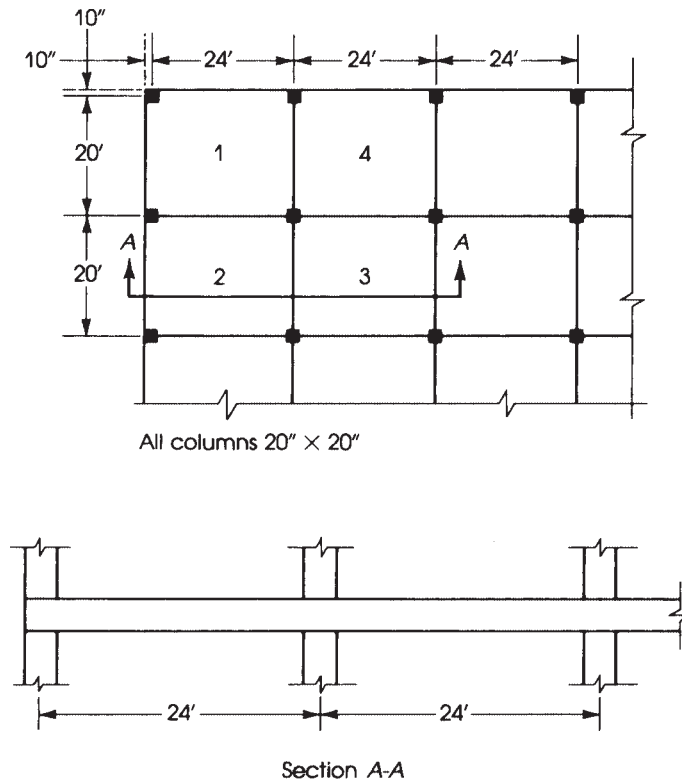


Figure 17.6 Example 17.1.

**Solution**

- For corner panel no. 1, the minimum thickness is  $l_n/30$  ( $f_y = 60$  ksi, and no edge beams are used; see Table 17.1).

$$l_{n_1} = 24 - \frac{20}{12} = 22.33 \text{ ft (long direction)}$$

$$\text{Min. } h = \frac{22.33 \times 12}{30} = 8.93 \text{ in. say, 9.0 in.}$$

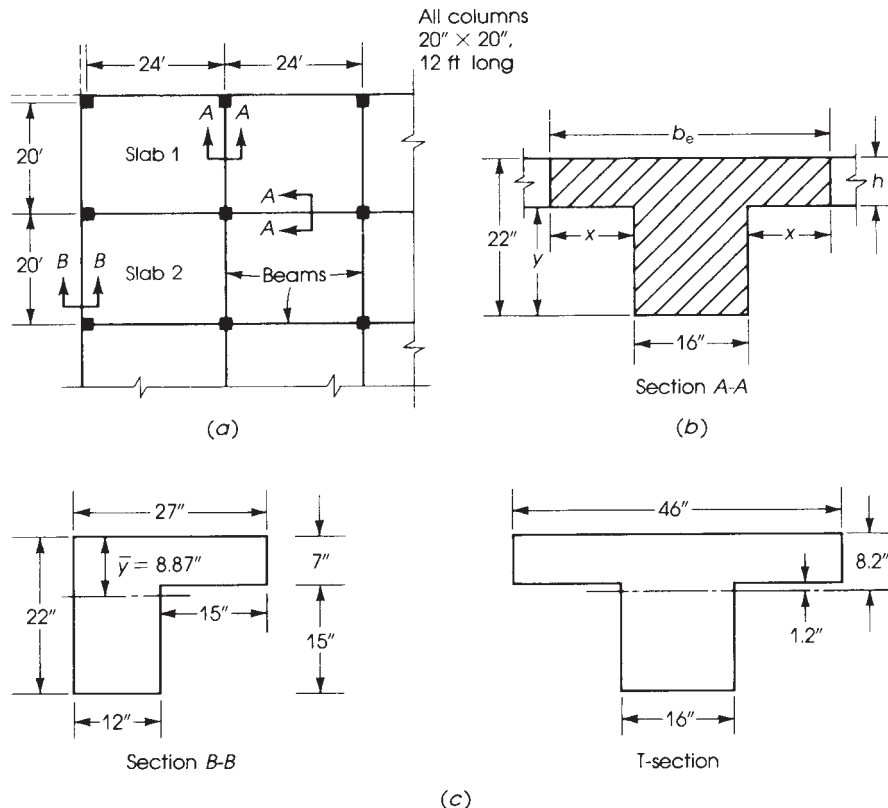
- For the interior panel no. 3 and  $f_y = 60$  ksi, the minimum slab thickness is  $l_n/33 = (22.33 \times 12)/33 = 8.12$  in., say, 8.5 in. is used for all panels, then  $h = 9.0$  in. will be adopted.

**Example 17.2**

The floor system shown in Fig. 17.7 consists of solid slabs and beams in two directions supported on 20-in. square columns. Using the ACI Code equations, determine the minimum slab thickness required for an interior panel. Use  $f'_c = 3$  ksi and  $f_y = 60$  ksi.

**Solution**

- To use Eq. 17.1,  $\alpha_m$  should be calculated first. Therefore, it is required to determine  $I_b$ ,  $I_s$ , and  $\alpha_f$  for the beams and slabs in the long and short directions.


**Figure 17.7** Example 17.2.

2. The gross moment of inertia of the beam,  $I_b$ , is calculated for the section shown in Fig. 17.7*b*, which is made up of the beam and the extension of the slab on each side of the beam  $x=y$  but not more than four times the slab thickness. Assume  $h=7$  in., to be checked later; then  $x=y=22-7=15$  in.  $< 4 \times 7=28$  in. Therefore,  $b_e=16+2 \times 15=46$  in., and the T-section is shown in Fig. 17.7*c*. Determine the centroid of the section by taking moments about the top of the flange:

$$\text{Area of flange} = 7 \times 46 = 322 \text{ in.}^2$$

$$\text{Area of web} = 16 \times 15 = 240 \text{ in.}^2$$

$$\text{Total area} = 562 \text{ in.}^2$$

$$(322 \times 3.5) + 240 \times (7 + 7.5) = 562\bar{y}$$

$$\bar{y} = 8.20 \text{ in.}$$

$$I_b = \left[ \frac{46}{12}(7)^3 + 322 \times (4.7)^2 \right] + \left[ \frac{16(15)^3}{12} + 240(7.5 - 1.2)^2 \right] = 22,453 \text{ in.}^4$$

3. The moment of inertia of the slab in the long direction is  $I_s = (bh^3)/12$ , where  $b=20$  ft and  $h=7$  in.

$$I_s = \frac{(20 \times 12)(7)^3}{12} = 6860 \text{ in.}^4$$

$$\alpha_{f1} \text{ (in the long direction)} = \frac{EI_b}{EI_s} = \frac{22,453}{6860} = 3.27$$

4. The moment of inertia of the slab in the short direction is  $I_s = (bh^3)/12$  where  $b=24$  ft and  $h=7$  in.

$$I_s = \frac{(24 \times 12)(7)^3}{12} = 8232 \text{ in.}^4$$

$$\alpha_{f2} \text{ (in the short direction)} = \frac{EI_b}{EI_s} = \frac{22,453}{8232} = 2.72$$

5.  $\alpha_{fm}$  is the average of  $\alpha_{f1}$  and  $\alpha_{f2}$ :

$$\alpha_{fm} = \frac{3.27 + 2.72}{2} = 3.23 > 2$$

- 6.

$$\beta = \frac{24 - \frac{20}{12}}{20 - \frac{20}{12}} = \frac{22.33}{18.33} = 1.22$$

7. Determine Min.  $h$  using Eq. 17.2 ( $l_n = 22.33$  ft):

$$h = \frac{(22.33 \times 12)(0.8 + 0.005 \times 60)}{36 + (9 \times 1.22)} = 6.27 \text{ in.} > 3.5 \text{ in.}$$

A slab thickness of 6.5 in. is adequate.

## 17.7 SHEAR STRENGTH OF SLABS

In a two-way floor system, the slab must have adequate thickness to resist both bending moments and shear forces at the critical sections. To investigate the shear capacity of two-way slabs, the following cases should be considered.

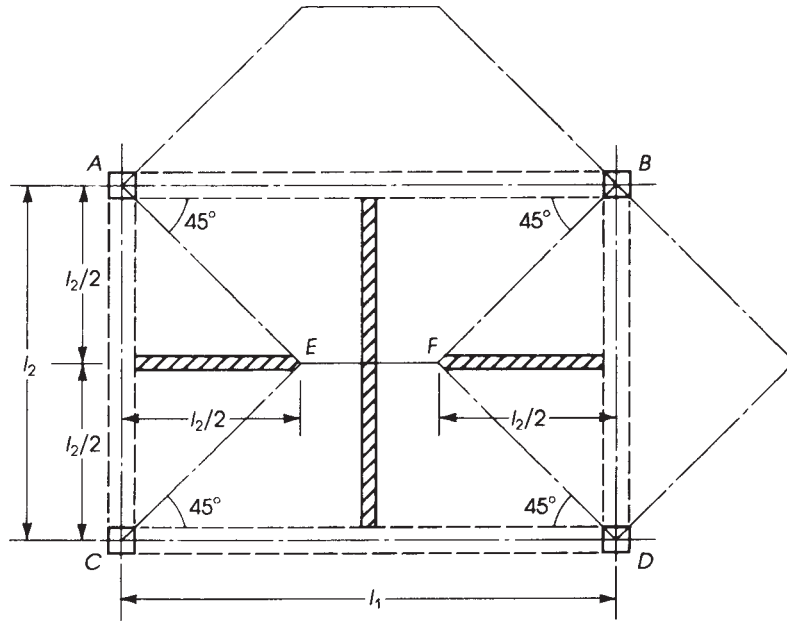


Figure 17.8 Areas supported by beams in two-way slab floor system.

### 17.7.1 Two-Way Slabs Supported on Beams

In two-way slabs supported on beams, the critical sections are at a distance  $d$  from the face of the supporting beams, and the shear capacity of each section is  $\phi V_c = \phi(2\lambda\sqrt{f'_c}bd)$ . When the supporting beams are stiff and are capable of transmitting floor loads to the columns, they are assumed to carry loads acting on floor areas bounded by  $45^\circ$  lines drawn from the corners, as shown in Fig. 17.8. The loads on the trapezoidal areas will be carried by the long beams  $AB$  and  $CD$ , whereas the loads on the triangular areas will be carried by the short beams  $AC$  and  $BD$ . The shear per unit width of slab is highest between  $E$  and  $F$  in both directions, and  $V_u = q_u(l_2/2)$ , where  $q_u$  is the uniform factored load per unit area.

If no shear reinforcement is provided, the shearing force at a distance  $d$  from the face of the beam,  $V_{ud}$ , must be equal to

$$V_{ud} \leq \phi V_c \leq \phi(2\lambda\sqrt{f'_c}bd)$$

where

$$V_{ud} = q_u \left( \frac{l_2}{2} - d \right)$$

### 17.7.2 Two-Way Slabs without Beams

In flat plates and flat slabs, beams are not provided, and the slabs are directly supported by columns. In such slabs, two types of shear stresses must be investigated; the first is one-way shear, or beam shear. The critical sections are taken at a distance  $d$  from the face of the column, and the slab is considered as a wide beam spanning between supports, as in the case of one-way beams. The shear capacity of the concrete section is  $\phi V_c = \phi(2\lambda\sqrt{f'_c}bd)$ . The second type of shear to be studied is two-way, or punching, shear, as was previously discussed in the design of footings. Shear failure

occurs along a truncated cone or pyramid around the column. The critical section is located at a distance  $d/2$  from the face of the column, column capital, or drop panel (Fig. 17.9a). If shear reinforcement is not provided, the shear strength of concrete is the smaller of Eqs. 17.6 and 17.7:

$$\phi V_c = \phi \left( 2 + \frac{4}{\beta} \right) \lambda \sqrt{f'_c} b_0 d \quad (17.5)$$

where

$b_0$  = perimeter of critical section

$\beta$  = ratio of long side of column (or loaded area) to short side

$$\phi V_c = \phi \left( \frac{\alpha_s d}{b_0} + 2 \right) \lambda \sqrt{f'_c} b_0 d \quad (17.6)$$

where  $\alpha_s$  is 40 for interior columns, 30 for edge columns, and 20 for corner columns.

$$\phi V_n \leq \phi(4\lambda\sqrt{f'_c}b_0d) \quad (17.7a)$$

When shear reinforcement is provided, the shear strength should not exceed

$$\phi V_n \leq \phi(6\sqrt{f'_c}b_0d) \quad (17.7b)$$

### 17.7.3 Shear Reinforcement in Two-Way Slabs without Beams

In flat-slab and flat-plate floor systems, the thickness of the slab selected may not be adequate to resist the applied shear stresses. In this case, either the slab thickness must be increased or shear reinforcement must be provided. The ACI Code allows the use of shear reinforcement by shearheads and anchored bars or wires.

Shearheads consist of steel I-shapes or channel shapes welded into four cross arms and placed in the slabs above the column (Figs. 17.9c, d). Shearhead designs do not apply to exterior columns, where large torsional and bending moments must be transferred between slab and column. The ACI Code, Section 22.6.9.10, indicates that on the critical section the nominal shear strength,  $V_n$ , should not exceed  $4\sqrt{f'_c}b_0d$ , but if shearhead reinforcement is provided,  $V_n$  should not exceed  $7\sqrt{f'_c}b_0d$ . To determine the size of the shearhead, the ACI Code, Section 22.6.9, gives the following limitations:

1. The ratio  $\alpha_v$  between the stiffness of shearhead arm,  $E_s I$ , and that of the surrounding composite cracked section of width,  $c_2 + d$ , must not be less than 0.15.
2. The compression flange of the steel shape must be located within  $0.3d$  of the compression surface of the slab.
3. The depth of the shear head must not exceed 70 times the web thickness.
4. The plastic moment capacity,  $M_p$ , of each arm of the shearhead is computed by

$$\phi M_p = \frac{V_u}{2n} \left[ h_v + \alpha_v \left( l_v - \frac{c_1}{2} \right) \right] \quad (\text{ACI Code, Eq. 22.6.9.6}) \quad (17.8)$$

where

$\phi$  = strength reduction factor for tensioned control members

$V_u$  = factored shear force around periphery of column face

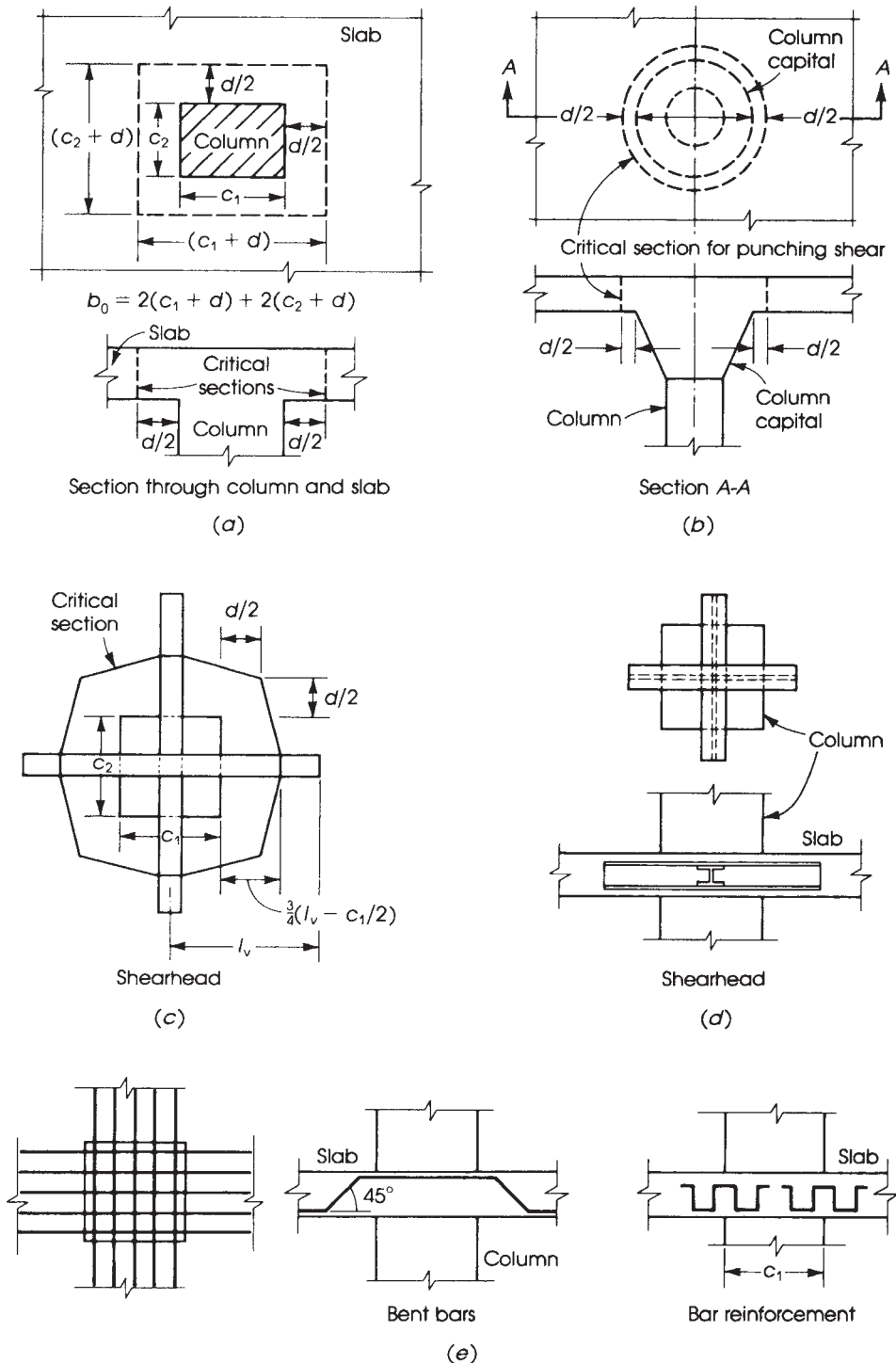
$N$  = number of arms

$h_v$  = depth of shearhead

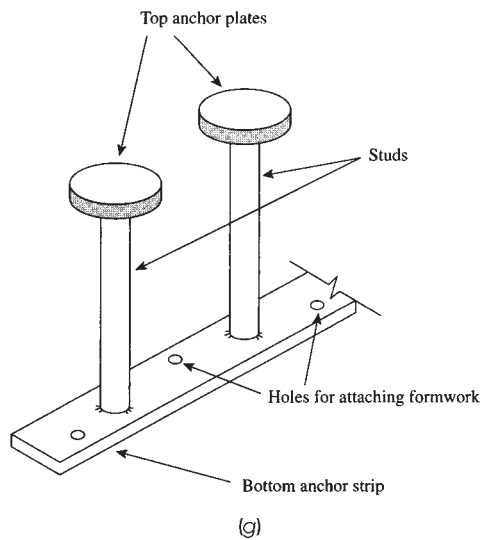
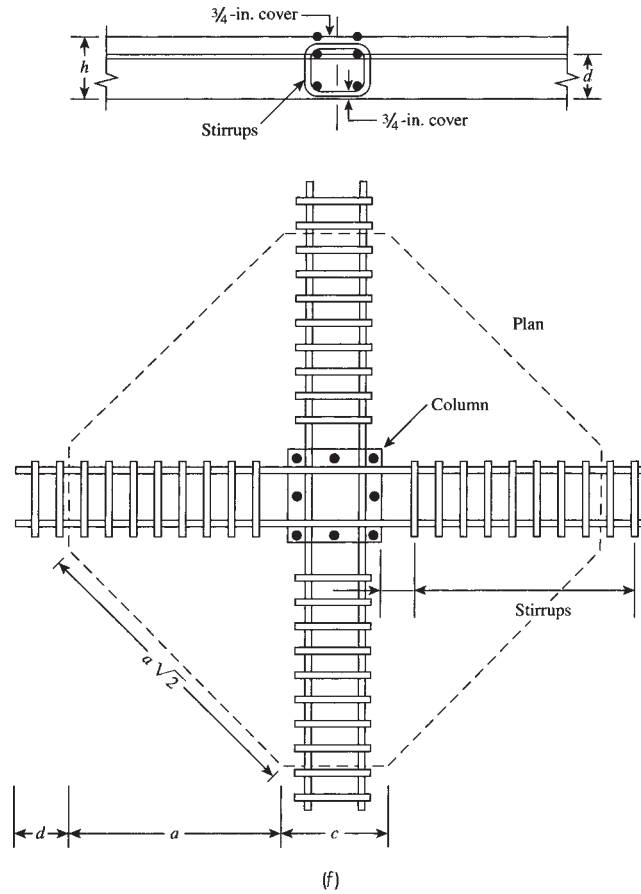
$l_v$  = length of shearhead measured from centerline of column

$c_1$  = dimension of rectangular, or equivalent rectangular, column

$\alpha_v$  = ratio of flexural stiffness of shearhead arm to that of the surrounding composite slab



**Figure 17.9** Critical section for punching shear in (a) flat plates and (b) flat slabs, reinforcement by (c, d) shearheads and (e) anchored bars, (f) conventional stirrup cages, and (g) studded steel strips used as shear reinforcement.



**Figure 17.9** (continued)



5. The critical slab section for shear must cross each shearhead arm at a distance equal to  $\left(\frac{3}{4}\right)(l_v - c_1/2)$  from the column face to the end of the shearhead arm, as shown in Fig. 17.9c. The critical section must have a minimum perimeter,  $b_0$ , but it should not be closer than  $d/2$  from the face of the column.
6. The shearhead is considered to contribute a moment resistance,  $M_v$ , to each slab column strip as follows:

$$M_v = \frac{\phi}{2n} \alpha_v V_u \left( l_v - \frac{c_1}{2} \right) \quad (\text{ACI Code, Eq. 22.6.9.7}) \quad (17.9)$$

but it should not be more than the smallest of 30% of the factored moment required in the column strip or the change in the column strip moment over the length  $l_v$  or  $M_p$  given in Eq. 17.8

The use of anchored single or multiple-leg stirrups is permitted by the ACI Code, Section 22.6.7.1 to be used as shear reinforcement provided that  $d > 6$  in. and  $d > 16d_b$  where  $d_b$  is the diameter of the stirrups. The bars are placed on top of the column, and the possible arrangements are shown in Fig. 17.9e. When bars or wires are used as shear reinforcement, the nominal shear strength is

$$V_n = V_c + V_s = (2\lambda\sqrt{f'_c})b_0d + \frac{A_v f_y d}{s} \quad (17.10)$$

where  $A_v$  is the total stirrup bar area and  $b_0$  is the length of the critical section of two-way shear at a distance  $d/2$  from the face of the column. The nominal shear strength,  $V_n$ , should not exceed  $6\lambda\sqrt{f'_c}b_0d$ . (ACI Code, Section 22.6.6.2)

The use of shear reinforcement in flat plates reduces the slab thickness and still maintains the flat ceiling to reduce the cost of formwork. Typical stirrup cages for shear reinforcement are shown in Fig. 17.9f. Another type of shear reinforcement consists of studded steel strips (Fig. 17.9g). The steel strip is positioned with bar chairs and fastened to the formwork, replacing the stirrup cages. The yield strength of the stud material is specified between 40 and 60 ksi to achieve complete anchorage at ultimate load.

## 17.8 ANALYSIS OF TWO-WAY SLABS BY THE DIRECT DESIGN METHOD

The direct design method is an approximate method established by the ACI Code to determine the design moments in uniformly loaded two-way slabs. To use this method, some limitations must be met, as indicated by the ACI Code, Section 8.10.2.

### 17.8.1 Limitations

1. There must be a minimum of three continuous spans in each direction.
2. The panels must be square or rectangular; the ratio of the longer to the shorter span within a panel must not exceed 2.0.
3. Adjacent spans in each direction must not differ by more than one-third of the longer span.
4. Columns must not be offset by a maximum of 10% of the span length, in the direction of offset, from either axis between centerlines of successive columns.
5. All loads shall be due to gravity only. All loads must be uniform, and the ratio of the unfactored live to unfactored dead load must not exceed 2.0.
6. If beams are present along all sides, the ratio of the relative stiffness of beams in two perpendicular directions,  $\alpha_{f_1} I_2^2 / \alpha_{f_2} I_1^2$  must not be less than 0.2 nor greater than 5.0.

### 17.8.2 Total Factored Static Moment

If a simply supported beam carries a uniformly distributed load  $w$  K/ft, then the maximum positive bending moment occurs at midspan and equals  $M_0 = q_u l_1^2 / 8$ , where  $l_1$  is the span length. If the beam is fixed at both ends or continuous with equal negative moments at both ends, then the total moment  $M_0 = M_p$  (positive moment at midspan) +  $M_n$  (negative moment at support) =  $q_u l_1^2 / 8$  (Fig. 17.10). Now if the beam  $AB$  carries the load  $W$  from a slab that has a width  $l_2$  perpendicular to  $l_1$ , then  $W = q_u l_2$ , and the total moment is

$$M_0 = \frac{(q_u l_2) l_1^2}{8}$$

where  $q_u$  is the load intensity in K/ft<sup>2</sup>. In this expression, the actual moment occurs when  $l_1$  equals the clear span between supports  $A$  and  $B$ . If the clear span is denoted by  $l_n$ , then

$$M_0 = \frac{q_u l_2 l_n^2}{8} \quad (\text{ACI Code, Eq. 8.10.3.2}) \quad (17.11)$$

The clear span,  $l_n$ , is measured face to face of supports in the direction in which moments are considered but not less than 0.65 times the span length from center to center of supports. The face of the support where the negative moments should be calculated is illustrated in Fig. 17.11. The length  $l_2$  is measured in a direction perpendicular to  $l_n$  and equals the direction between center to center of supports (width of slab). The total moment  $M_0$  calculated in the long direction will be referred to here as  $M_{0l}$  and that in the short direction, as  $M_{0s}$ .

Once the total moment,  $M_0$ , is calculated in one direction, it is divided into a positive moment,  $M_p$ , and a negative moment,  $M_n$ , such that  $M_0 = M_p + M_n$  (Fig. 17.10). Then each moment,  $M_p$  and  $M_n$ , is distributed across the width of the slab between the column and middle strips, as is explained shortly.

### 17.8.3 Longitudinal Distribution of Moments in Slabs

In a typical *interior panel*, the total static moment,  $M_0$ , is divided into two moments, the positive moment,  $M_p$ , at midspan, equal to  $0.35M_0$ , and the negative moment,  $M_n$ , at each support, equal to  $0.65M_0$ , as shown in Fig. 17.12. These values of moment are based on the assumption that the interior panel is continuous in both directions, with approximately equal spans and loads, so that the interior joints have no significant rotation. Moreover, the moment values are approximately the

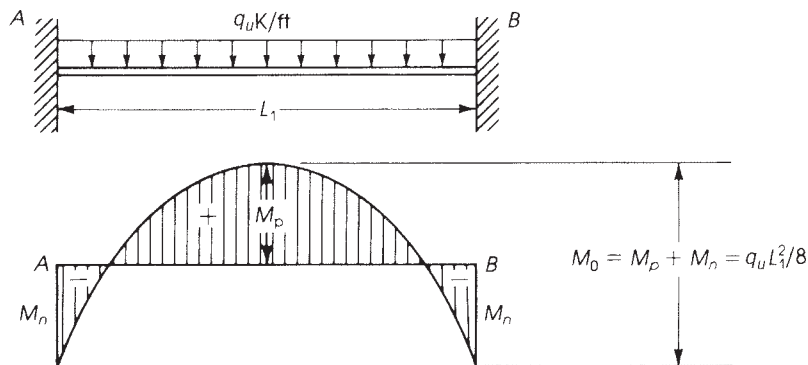
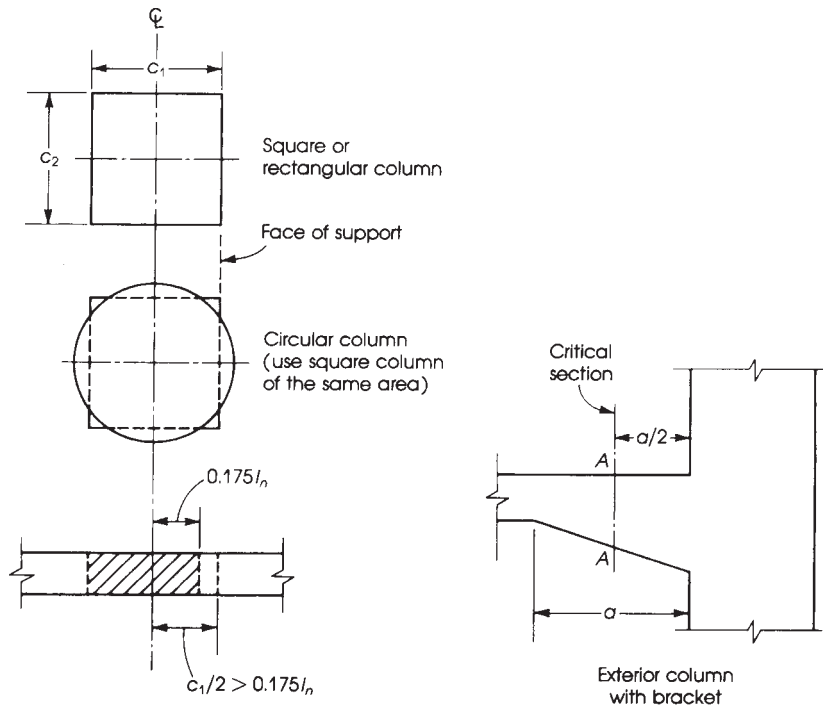


Figure 17.10 Bending moment in a fixed-end beam.



**Figure 17.11** Critical sections for negative design moments. A-A, section for negative moment at exterior support with bracket.

same as those in a fixed-end beam subjected to uniform loading, where the negative moment at the support is twice the positive moment at midspan. In Fig. 17.12, if  $l_1 > l_2$ , then the distribution of moments in the long and short directions is as follows:

$$M_{0l} = (q_u l_2) \frac{l_1^2}{8} \quad M_{pl} = 0.35M_{0l} \quad M_{nl} = 0.65M_{0l}$$

$$M_{0s} = (q_u l_1) \frac{l_2^2}{8} \quad M_{ps} = 0.35M_{0s} \quad M_{ns} = 0.65M_{0s}$$

If the magnitudes of the negative moments on opposite sides of an interior support are different because of unequal span lengths, the ACI Code specifies that the larger moment should be considered to calculate the required reinforcement.

In an *exterior panel*, the slab load is applied to the exterior column from one side only, causing an unbalanced moment and a rotation at the exterior joint. Consequently, there will be an increase in the positive moment at midspan and in the negative moment at the first interior support. The magnitude of the rotation of the exterior joint determines the increase in the moments at midspan and at the interior support. For example, if the exterior edge is a simple support, as in the case of a slab resting on a wall (Fig. 17.13), the slab moment at the face of the wall there is 0, the positive moment at midspan can be taken as  $M_p = 0.63M_0$ , and the negative moment at the interior support is  $M_n = 0.75M_0$ . These values satisfy the static equilibrium equation

$$M_0 = M_p + \frac{1}{2}M_n = 0.63M_0 + \frac{1}{2}(0.75M_0)$$

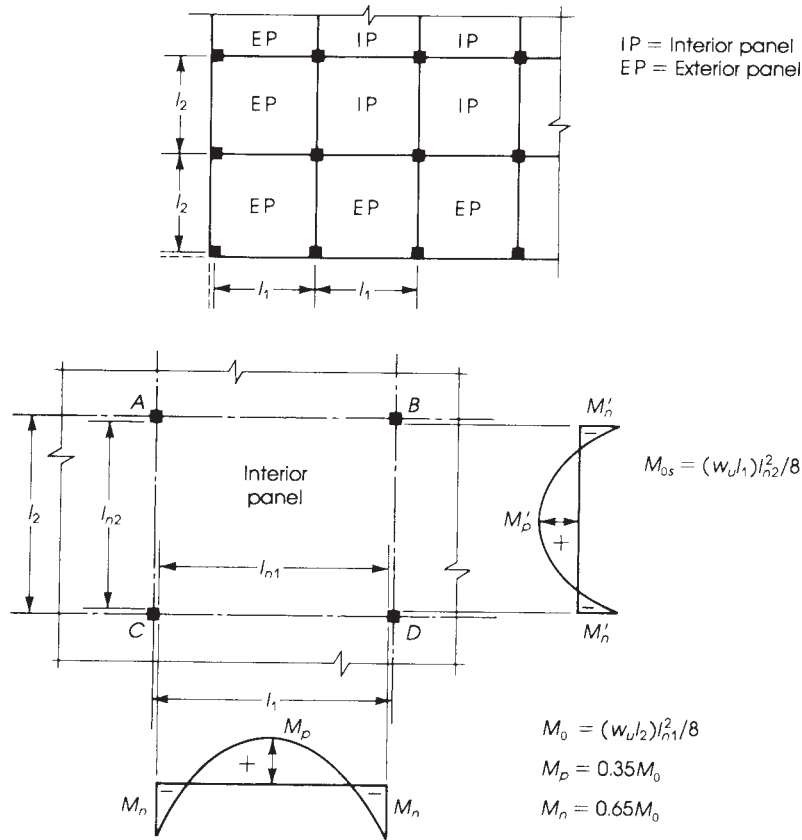


Figure 17.12 Distribution of moments in an interior panel.

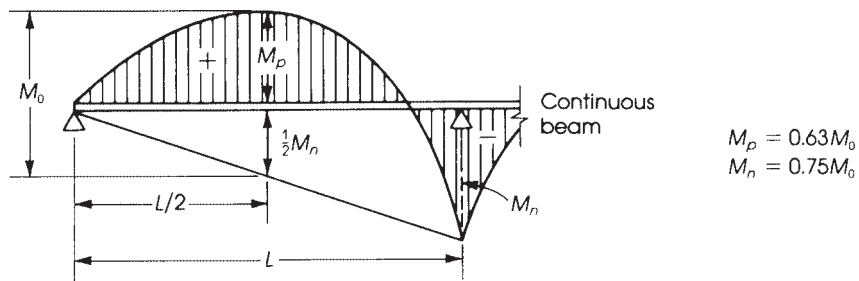


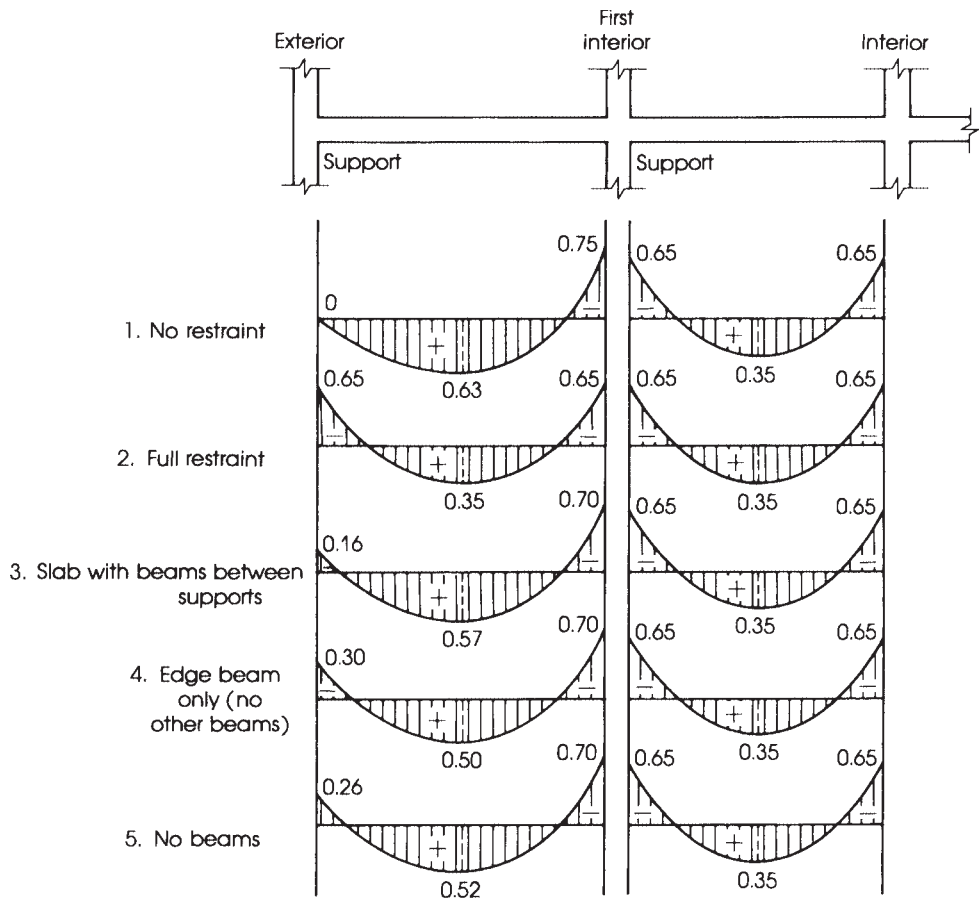
Figure 17.13 Exterior panel.

In a slab-column floor system, there is some restraint at the exterior joint provided by the flexural stiffness of the slab and by the flexural stiffness of the exterior columns.

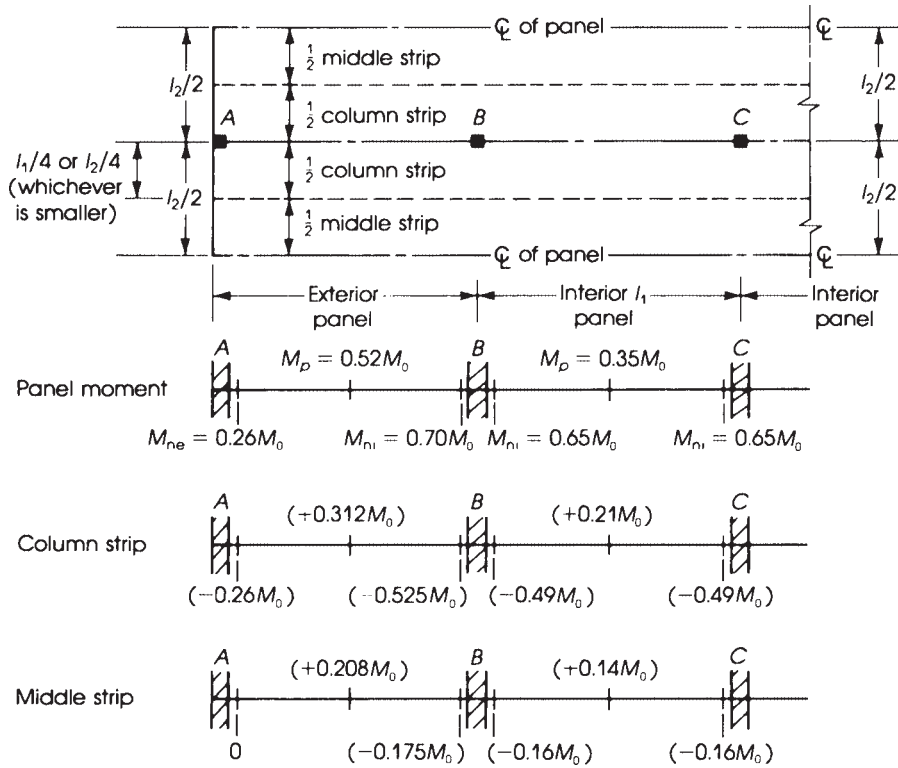
According to ACI Code, Section 8.10.4 the total static moment  $M_o$  in an end span is distributed in different ratios according to Table 17.2 and Fig. 17.14. The moment coefficients in column 1 for an unrestrained edge are based on the assumption that the ratio of the flexural stiffness of columns to the combined flexural stiffness of slabs and beams at a joint,  $\alpha_{ec}$  is equal to 0. The coefficients of

**Table 17.2** Distribution of Moments in an End Panel

	Exterior Edge		Slab with Beams between All Supports (3)	Slab without Beams between Interior Supports	
	Unrestrained (1)	Fully Restrained (2)		With Edge Beam (4)	Without Edge Beam (5)
	Exterior negative factored moment	0	0.65	0.16	0.30
Positive factored moment	0.63	0.35	0.57	0.50	0.52
Interior negative factored moment	0.75	0.65	0.70	0.70	0.70



**Figure 17.14** Distribution of total static moment into negative and positive span moments.



**Figure 17.15** Width of the equivalent rigid frame (equal spans in this figure) and distribution of moments in flat plates, flat slabs, and waffle slabs with no beams.

column 2 are based on the assumption that the ratio  $\alpha_{ec}$  is equal to infinity. The moment coefficients in columns 3, 4, and 5 have been established by analyzing the slab systems with different geometries and support conditions.

#### 17.8.4 Transverse Distribution of Moments

The longitudinal moment values mentioned in the previous section are for the entire width of the equivalent building frame. This frame width is the sum of the widths of two half-column strips and two half-middle strips of two adjacent panels, as shown in Fig. 17.15. The transverse distribution of the longitudinal moments to the middle and column strips is a function of the ratios  $l_2/l_1$ ,

$$\alpha_f = \frac{E_{cb}I_b}{E_{cs}I_s} = \frac{\text{beam stiffness}}{\text{slab stiffness}} \quad (17.12)$$

$$\beta_t = \frac{E_{cb}C}{2E_{cs}I_s} = \frac{\text{torsional rigidity of edge beam section}}{\text{flexural rigidity of slab of width equal to beam span length}} \quad (17.13)$$

where

$$C = \text{torsional constant} = \sum \left( 1 - \frac{0.63x}{y} \right) \left( \frac{x^3y}{3} \right) \quad (17.14)$$

where  $x$  and  $y$  are the shorter and longer dimension of each rectangular component of the section. The percentages of each design moment to be distributed to column and middle strips for interior and exterior panels are given in Tables 17.3 through Table 17.6. In a typical *interior* panel, the portion of the design moment that is not assigned to the column strip (Table 17.3) must be resisted by the corresponding half-middle strips. Linear interpolation of values of  $l_2/l_1$  between 0.5 and 2.0 and of  $\alpha_f l_2/l_1$  between 0 and 1 is permitted by the ACI Code. From Table 17.3 it can be seen that when no beams are used, as in the case of flat plates or flat slabs,  $\alpha_{f1} = 0$ . The final percentage of moments in the column and middle strips as a function of  $M_0$  are given in Table 17.4.

For *exterior* panels, the portion of the design moment that is not assigned to the column strip (Table 17.5) must be resisted by the corresponding half-middle strips. Again, linear interpolation

**Table 17.3** Percentage of Longitudinal Moment in Column Strips, Interior Panels (ACI Code, Section 8.10.5)

	$\alpha_f l_2/l_1$	Aspect Ratio, $l_2/l_1$		
		0.5	1.0	2.0
Negative moment at interior support	0	75	75	75
	$\geq 1.0$	90	75	45
Positive moment near midspan	0	60	60	60
	$\geq 1.0$	90	75	45

**Table 17.4** Percentage of Moments in Two-Way Interior Slabs without Beams ( $\alpha_1 = 0$ )

	Total Design Moment = $M_0 = (w_u l_2) \left( \frac{l_2}{8} \right) \frac{n!}{r!(n-r)!}$	
	Negative Moment	Positive Moment
Longitudinal moments in one panel	$-0.65M_0$	$\pm 0.35M_0$
Column strip	$0.75(-0.65M_0) = -0.49M_0$	$0.60(0.35M_0) = 0.21M_0$
Middle strip	$0.25(-0.65M_0) = 0.16M_0$	$0.40(0.35M_0) = 0.14M_0$

**Table 17.5** Percentage of Longitudinal Moment in Column Strips, Exterior Panels (ACI Code, Section 8.10.5)

	$\alpha_f l_2/l_1$	$\beta_t$	Aspect Ratio $l_2/l_1$		
			0.5	1.0	2.0
Negative moment at exterior support	0	0	100	100	100
	$\geq 1.0$	$\geq 2.5$	75	75	75
		$\geq 2.5$	100	100	100
Positive moment near midspan	0		90	75	45
	$\geq 1.0$		60	60	60
			90	75	45
Negative moment at interior support	0		75	75	75
	$\geq 1.0$		90	75	45

**Table 17.6** Percentage of Longitudinal Moment in Column and Middle Strips, Exterior Panels (for All Ratios of  $l_2/l_1$ ), Given  $\alpha_t = \beta_t = 0$ 

	Percent	Column Strip	Middle Strip	Final Moment as a Function of $M_0$ and $\alpha_{ec}$ (Column Strip)
Negative moment at exterior support	100	$0.26M_0$	0	$\left[ \frac{0.65}{(1+1/\alpha_{ec})} \right] (M_0)$
Positive moment ( $0.6 \times 0.52M_0$ )	60	$0.312M_0$	$0.208M_0$	$\left[ 0.63 - \frac{0.28}{(1+1/\alpha_{ec})} \right] (M_0)$
Negative moment at interior support ( $0.75 \times 0.70M_0$ )	75	$0.525M_0$	$0.175M_0$	$\left[ 0.75 - \frac{0.10}{(1+1/\alpha_{ec})} \right] (M_0)$

between values shown in Table 17.5 is permitted by the ACI Code, Section 8.10.5. When no beams are used in an exterior panel, as in the case of flat slabs or flat plates with no edge (spandrel) beam,  $\alpha_{f1} = 0$ ,  $C = 0$ , and  $\beta_t = 0$ . This means that the end column provides the restraint to the exterior end of the slab. The applicable values of Table 17.5 for this special case are shown in Table 17.6 and Fig. 17.15.

From Table 17.6 it can be seen that when no edge beam is used at the exterior end of the slab,  $\beta_t = 0$  and 100% of the design moment is resisted by the column strip. The middle strip will not resist any moment; therefore, minimum steel reinforcement must be provided. The ACI Code, Section 8.10.5.4, specifies that when the exterior support is a column or wall extending for a distance equal to or greater than  $3/4$  the transverse span length,  $l_2$ , used to compute  $M_0$ , the exterior negative moment is to be uniformly distributed across  $l_2$ . When beams are provided along the centerlines of columns, the ACI Code, Section 8.10.5.7, requires that beams must be proportioned to resist 85% of the moment in the column strip if  $\alpha_{f1} l_2/l_1 > 1.0$ . For values of  $\alpha_{f1} (l_2/l_1)$  between 1.0 and 0, the moment assigned to the beam is determined by linear interpolation between 85% and 0%. Beams must also be proportioned to resist additional moments caused by all loads applied directly to the beams, including the weight of the projecting beam stem above and below the floor slab. The portion of the moment that is not assigned to the beam must be resisted by the slab in the column strip.

### 17.8.5 ACI Provisions for Effects of Pattern Loadings

In continuous structures, the maximum and minimum bending moments at the critical sections are obtained by placing the live load in specific patterns to produce the extreme values. Placing the live load on all spans will not produce either the maximum positive or negative bending moments. The maximum and minimum moments depend mainly on the following:

1. The ratio of live to dead load. A high ratio will increase the effect of pattern loadings.
2. The ratio of column to beam stiffnesses. A low ratio will increase the effect of pattern loadings.
3. Pattern loadings. Maximum positive moments within the spans are less affected by pattern loadings.



To determine the design factored moments in continuous structures, the ACI Code, Section 6.4.3, specifies the following:

1. When the loading pattern is known, the equivalent frame shall be analyzed for that load.
2. When the unfactored live load is variable but does not exceed  $\frac{3}{4}$  of the unfactored dead load,  $q_L \leq 0.75 q_D$ , or when all the panels is almost loaded simultaneously with the live load, it is permitted to analyze the frame with full factored live load on the entire slab system.
3. For other loading conditions, it is permitted to assume that the maximum positive factored moment near a midspan occurs with 0.75 of the full factored live load on the panel and alternate panels. For the maximum negative factored moment in the slab at a support, it is permitted to assume that 0.75 of the full factored live load is applied on adjacent panels only.
4. Factored moments shall not be taken less than the moments occurring with full factored live load on all continuous panels.

### 17.8.6 Reinforcement Details

After all the percentages of the static moments in the column and middle strips are determined, the steel reinforcement can be calculated for the negative and positive moments in each strip, as was done for beam sections in Chapter 4:

$$M_u = \phi A_s f_y \left( d - \frac{a}{2} \right) = R_u b d^2 \quad (17.15)$$

Calculate  $R_u$  and determine the steel ratio  $\rho$  using the tables in Appendix A or use the following equation:

$$R_u = \phi \rho f_y \left( 1 - \frac{\rho f_y}{1.7 f'_c} \right) \quad (17.16)$$

where  $\phi$  equals 0.9. The steel area is  $A_s = \rho b d$ . When the slab thickness limitations, as discussed in Section 17.4, are met, no compression reinforcement will be required. Figure 13.3.8 of the ACI Code indicates the minimum length of reinforcing bars and reinforcement details for slabs without beams; it is reproduced here as Fig. 17.16. The spacing of bars in the slabs must not exceed the ACI limits of maximum spacing: 18 in. (450 mm) or twice the slab thickness, whichever is smaller.

### 17.8.7 Modified Stiffness Method for End Spans

In this method, the stiffnesses of the slab end beam and of the exterior column are replaced by the stiffness of an equivalent column,  $K_{ec}$ . The flexural stiffness of the equivalent column,  $K_{ec}$ , can be calculated from the following expression:

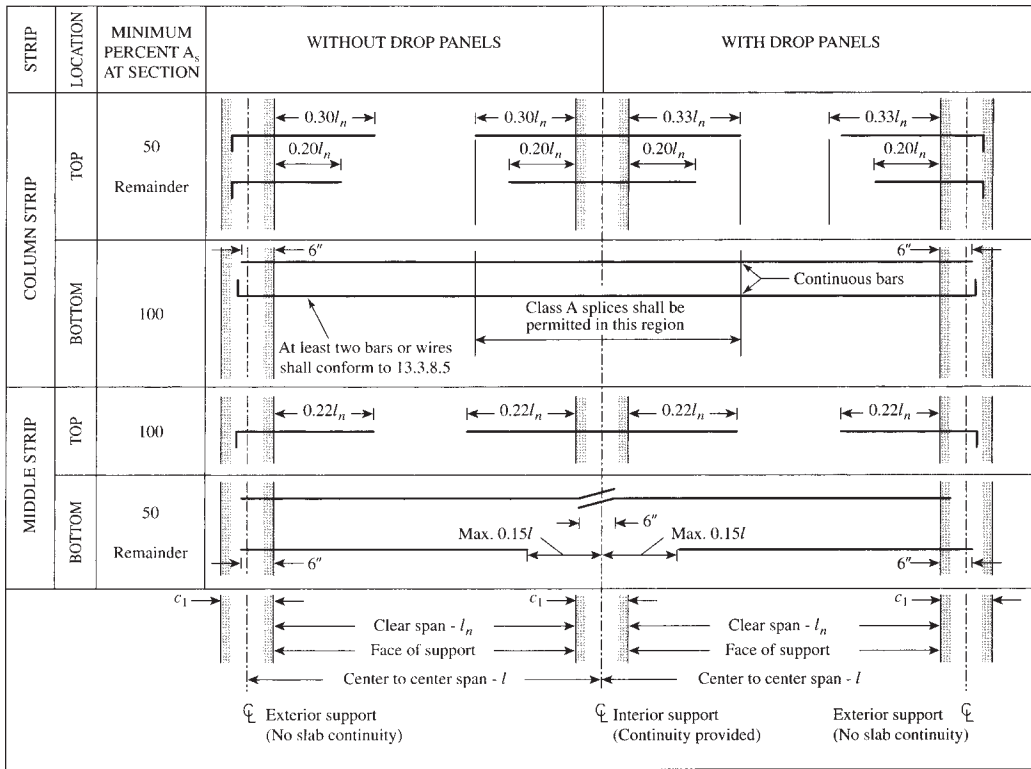
$$\frac{1}{K_{ec}} = \frac{1}{\sum K_c} + \frac{1}{K_t} \quad \text{or} \quad K_{ec} = \frac{\sum K_c}{1 + \sum K_c / K_t} \quad (17.17)$$

where

$K_{ec}$  = flexural stiffness of equivalent column

$K_c$  = flexural stiffness of actual column

$K_t$  = torsional stiffness of edge beam



**Figure 17.16** Minimum extensions for reinforcement in slabs without beams (ACI Code, Fig. R8.7.4.1.3(b)). Courtesy of American Concrete Institute [14]

The sum of the flexural stiffness of the columns above and below the floor slab can be taken as follows:

$$\sum K_c = 4E \left( \frac{I_{c1}}{L_{c1}} + \frac{I_{c2}}{L_{c2}} \right) \tag{17.18}$$

where  $I_{c1}$  and  $L_{c1}$  are the moment of inertia and length of column above slab level and  $I_{c2}$  and  $L_{c2}$  are the moment of inertia and length of column below slab level. The torsional stiffness of the end beam,  $K_t$ , may be calculated as follows:

$$K_t = \sum \frac{9E_{cs}C}{l_2(1 - c_2/l_2)^3} \tag{17.19}$$

where

$c_2$  = size of rectangular or equivalent rectangular column, capital, or bracket measured on transverse spans on each side of column

$E_{cs}$  = modulus of elasticity of slab concrete

$C$  = torsion constant determined from following expression:

$$C = \sum \left( 1 - 0.63 \frac{x}{y} \right) \left( \frac{x^3 y}{3} \right) \tag{17.20}$$

where  $x$  is the shorter dimension of each component rectangle and  $y$  is the longer dimension of each component rectangle. In calculating  $C$ , the component rectangles of the cross section must be taken in such a way as to produce the largest value of  $C$ .

The preceding expressions are introduced here and will also be used in Section 17.12, Equivalent Frame Method.

If a panel contains a beam parallel to the direction in which moments are being determined, the torsional stiffness,  $K_t$ , given in Eq. 17.19 must be replaced by a greater value,  $K_{ta}$ , computed as follows:

$$K_{ta} = K_t \times \frac{I_{sb}}{I_s}$$

where

$$I_s = l_2 h^3 / 12 = \text{moment of inertia of a slab that has a width equal to full width between panel centerlines (excluding that portion of beam stem extending above or below slab)}$$

$$I_{sb} = I_s, \text{ including portion of beam stem extending above or below slab}$$

Cross sections of some attached torsional members are shown in Fig. 17.17. Once  $K_{ec}$  is calculated, the stiffness ratio,  $\alpha_{ec}$ , is obtained as follows:

$$\alpha_{ec} = \frac{K_{ec}}{\sum(K_s + K_b)} \quad (17.21)$$

where

$$K_s = \frac{4E_{cs}I_s}{l_1} = \text{flexural stiffness of slab}$$

$$K_b = \frac{4E_{cb}I_b}{l_1} = \text{flexural stiffness of beam}$$

$$I_b = \text{gross moment of inertia of longitudinal beam section}$$

The distribution of the total static moment,  $M_0$ , in an exterior panel is given as a function of  $\alpha_{ec}$  as follows:

$$\text{Interior negative factored moment} = \left( 0.75 - \frac{0.1}{(1 + 1/\alpha_{ec})} \right) M_0$$

$$\text{Positive factored moment} = \left( 0.63 - \frac{0.28}{(1 + 1/\alpha_{ec})} \right) M_0$$

$$\text{Exterior negative factored moment} = \left( \frac{0.65}{(1 + 1/\alpha_{ec})} \right) M_0$$

These values are shown for a typical exterior panel in Fig. 17.18. These factors take into consideration the effect of the stiffness of the exterior column as well as the slab end beam giving adequate distribution of moments.

### 17.8.8 Summary of the Direct Design Method (DDM)

**Case 1.** Slabs without beams (flat slabs and flat plates).

1. Check the limitation requirements explained in Section 17.8.1. If limitations are not met, DDM cannot be used.

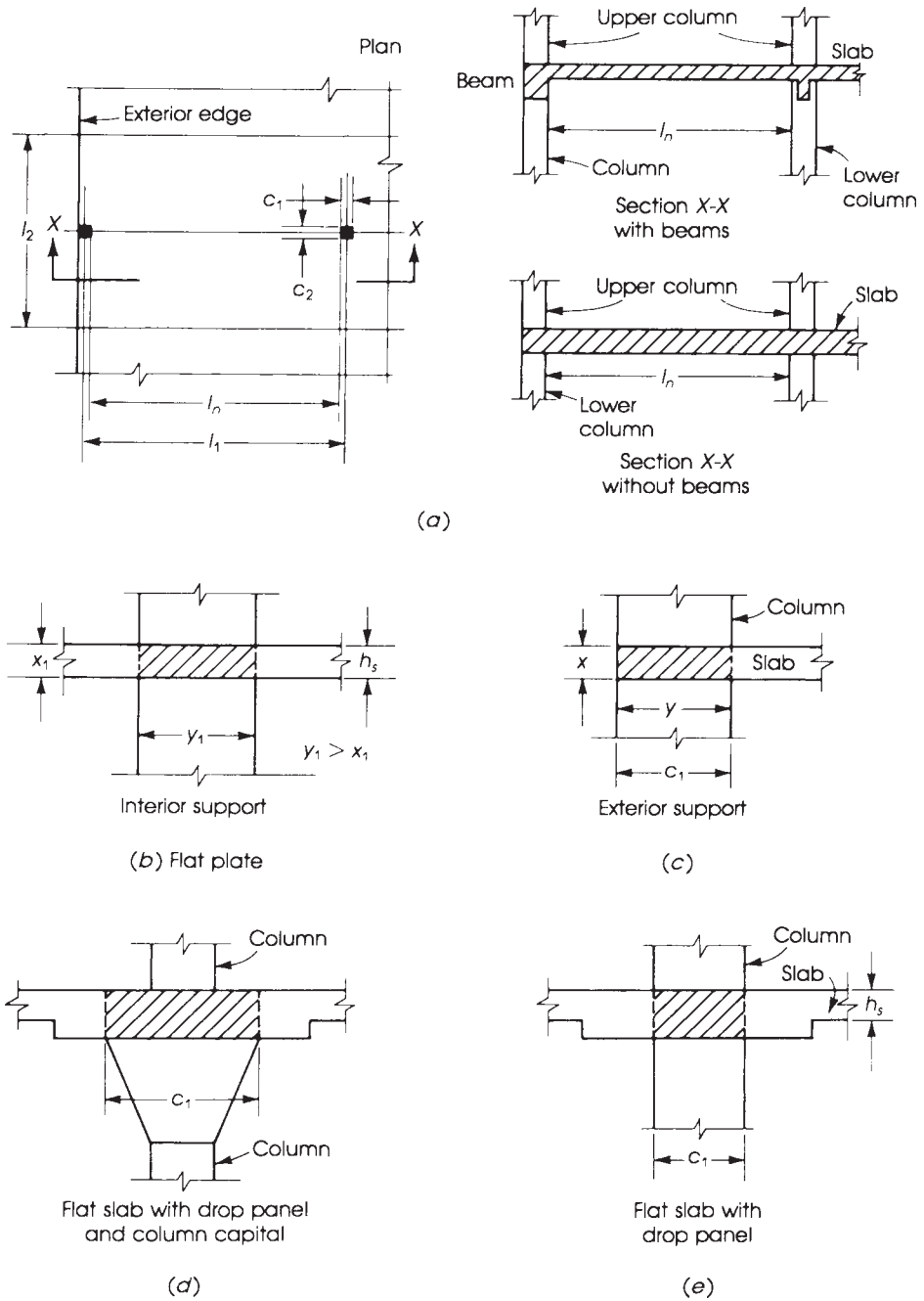


Figure 17.17 Cross sections of some attached torsional members.

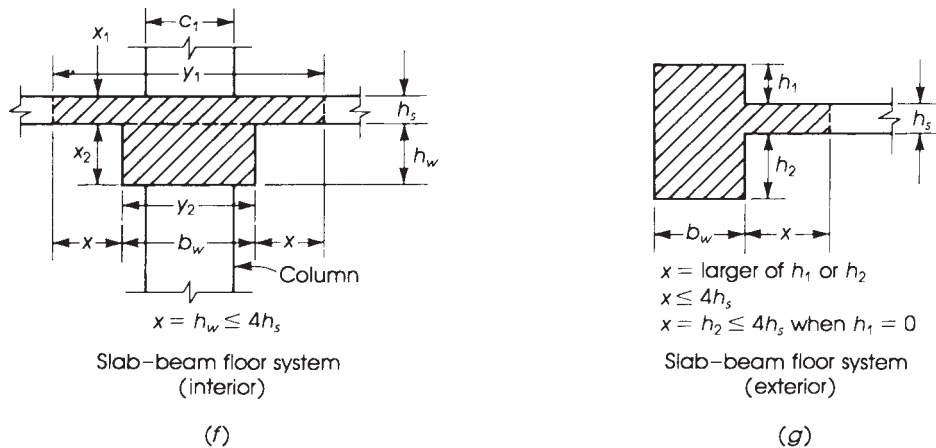


Figure 17.17 (continued)

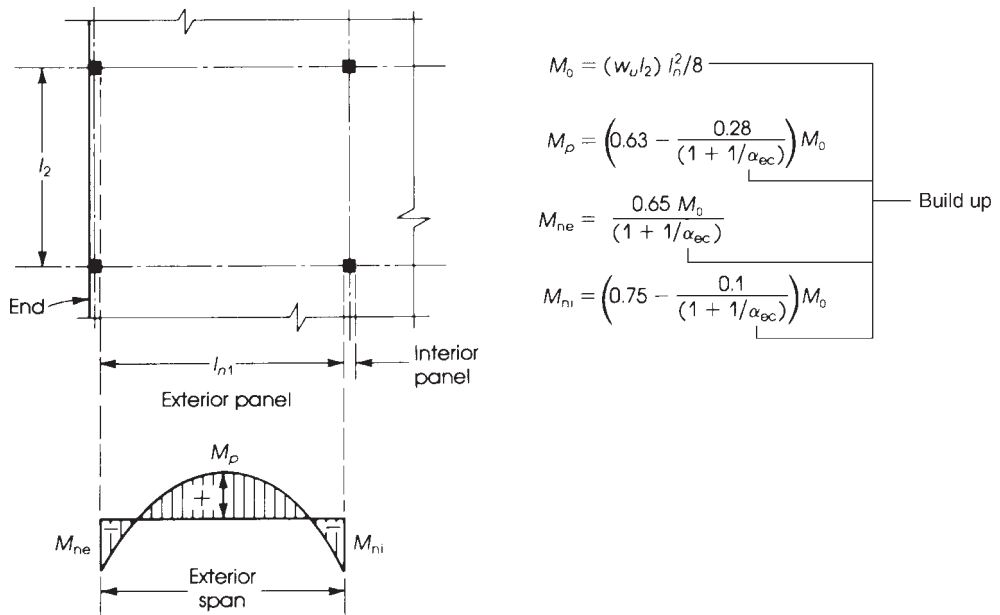


Figure 17.18 Distribution of moments in an exterior panel.

2. Determine the minimum slab thickness ( $h$ ) to control deflection using values in Table 17.1. Exterior panels without edge beams give the highest minimum  $h = (l_n/30)$  for  $f_y = 60$  ksi). It is a common practice to use the same slab depth for all exterior and interior panels.
3. Calculate the factored loads,  $q_u = 1.2 q_{Du} + 1.6 q_{Lu}$ .
4. Check the slab thickness,  $h$ , as required by one-way and two-way shear. If the slab thickness,  $h$ , is not adequate, either increase  $h$  or provide shear reinforcement.
5. Calculate the total static moment,  $M_0$ , in both directions (Eq. 17.11).

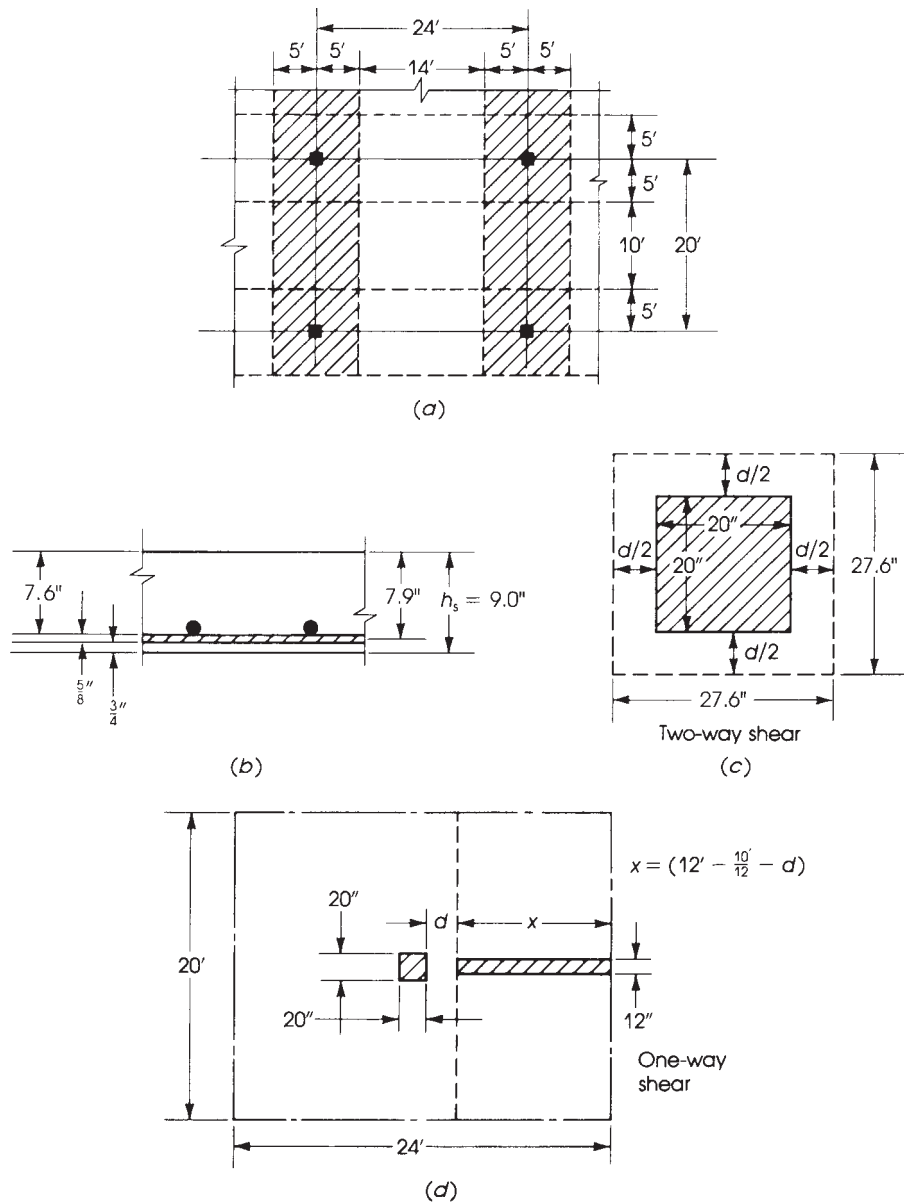
6. Determine the distribution factors for the positive and negative moments in the longitudinal and transverse directions for each column and middle strip in both interior and exterior panels as follows:
  - a. For interior panels, use the moment factors given in Table 17.4 or Fig. 17.15.
  - b. For exterior panels without edge beams, the panel moment factors are given in Table 17.2 or Fig. 17.14 (Case 5). For the distribution of moments in the transverse direction, use Table 17.6 or Fig. 17.15 for column-strip ratios. The middle strip will resist the portion of the moment that is not assigned to the column strip.
  - c. For exterior panels with edge beams, the panel moment factors are given in Table 17.2 or Fig. 17.14 (Case 4). For the distribution of moments in the transverse direction, use Table 17.5 for the column strip. The middle strip will resist the balance of the panel moment.
7. Determine the steel reinforcement for all critical sections of the column and middle strips and extends the bars throughout the slab according to Fig. 17.16.
8. Compute the unbalanced moment and check if transfer of unbalanced moment by flexure is adequate. If not, determine the additional reinforcement required in the critical width. (Refer to Section 17.10.)
9. Check if transfer of the unbalanced moment by shear is adequate. If not, increase  $h$  or provide shear reinforcement. (Refer to Section 17.10.)

**Case 2.** Slabs with interior and exterior beams.

1. Check the limitation requirements as explained in Section 17.8.1.
2. Determine the minimum slab thickness ( $h$ ) to control deflection using Eqs. 17.1 through 17.3. In most cases Eq. 17.2 controls.
3. Calculate the factored load,  $W_u$ .
4. Check the slab thickness,  $h$ , according to one-way and two-way shear requirements. In general, shear is not critical for slabs supported on beams.
5. Calculate the total static moment,  $M_0$  in both directions (Eq. 17.17).
6. Determine the distribution factors for the positive and negative moments in the longitudinal and transverse directions for each column and middle strips in both interior and exterior panels as follows:
  - a. For interior panels, use moment factors in Fig. 17.14 (Case 3) or Fig. 17.12. For the distribution of moments in the transverse direction, use Table 17.3 for column strips. The middle strips will resist the portion of the moments not assigned to the column strips. Calculate  $\alpha_1$  from Eq. 17.12.
  - b. For exterior panels, use moment factors in Table 17.2 or Fig. 17.14 (Case 3). For the distribution of moments in the transverse direction, use Table 17.5 for the column strip. The middle strip will resist the balance of the panel moment.
  - c. In both cases (a) and (b), the beams must resist 85% of the moment in the column strip when  $\alpha_f(l_2/l_1) \geq 1.0$ , whereas the ratio varies between 85 and 0% when  $\alpha_f(l_2/l_1)$  varies between 1.0 and 0.
7. Determine the steel reinforcement for all critical sections in the column strip, beam, and middle strip; then extend the bars throughout the slab according to Fig. 17.16.
8. Compute the unbalanced moment and then check the transfer of moment by flexure and shear. (Refer to Section 17.10.)

**Example 17.3**

Using the direct design method, design the typical *interior flat-plate* panel shown in Figs. 17.6 and 17.19. The floor system consists of four panels in each direction with a panel size of  $24 \times 20$  ft. All panels are supported by  $20 \times 20$ -in. columns, 12 ft long. The slab carries a uniform service live load of 100 psf and a service dead load that consists of 24 psf of floor finish in addition to the slab self-weight. Use normal-weight concrete with  $f'_c = 4$  ksi and  $f_y = 60$  ksi.



**Figure 17.19** Example 17.3: Interior flat plate.

**Solution**

- Determine the minimum slab thickness using Table 17.1 for flat plates. From Example 17.1, a 9-in. slab thickness is adopted.
- Calculate the factored loads:

$$q_D = 24 + \text{weight of slab} = 24 + \frac{9.0}{12} \times 150 = 136.5 \text{ psf}$$

$$q_u = 1.2 \times (136.5) + 1.6 \times (100) = 323 \text{ say, } 330 \text{ psf}$$

- Check one- and two-way shears:
  - Check punching shear at a distance  $d/2$  from the face of the column (two-way action): Assuming  $\frac{3}{4}$ -in. concrete cover and no. 5 bars, then the average  $d$  is  $9.0 - 0.75 - \frac{5}{8} = 7.6$  in. and  $b_0 = 4(20 + 7.6) = 110$  in. (See Fig. 17.19c).

$$V_u = \left[ l_1 l_2 - \left( \frac{27.6}{12} \times \frac{27.6}{12} \right) \right] \times q_u = (24 \times 20 - 5.3) \times 0.330 = 156.7 \text{ K}$$

$$\phi V_c = \phi \left( 2 + \frac{4}{\beta} \right) \sqrt{f'_c} b_0 d$$

$$\beta = \frac{24}{20} = 1.2$$

$$= 0.75 \left( 2 + \frac{4}{1.2} \right) \times \frac{\sqrt{4000}}{1000} \times 110 \times 7.6$$

$$= 211.5 \text{ K}$$

$$\phi V_c = \phi \left( \frac{\alpha_s d}{b_0} + 2 \right) \sqrt{f'_c} b_0 d$$

$$\alpha_s = 40 \quad (\text{Interior Column})$$

$$\phi V_c = 0.75 \left( \frac{40 \times 7.6}{110} + 2 \right) \frac{\sqrt{4000}}{1000} \times 110 \times 7.6$$

$$= 188.9 \text{ K}$$

$$\phi V_c = \phi(4\sqrt{f'_c})b_0 d = \frac{0.75 \times 4}{1000} \times \sqrt{4000} \times 110 \times 7.6 = 158.6 \text{ K (controls)}$$

which is greater than  $V_u$ .

- Check beam shear at a distance  $d$  from the face of the column; average  $d$  is 7.6 in. Consider a 1-ft strip (Fig. 17.19d), with the length of the strip being

$$x = 12 - \frac{10}{12} - \frac{7.6}{12} = 10.5 \text{ ft}$$

$$V_u = q_u(1 \times 10.5) = 0.330 \times 1 \times 10.5 = 3.47 \text{ K}$$

$$\phi V_c = \phi(2\lambda\sqrt{f'_c})bd = \frac{0.75 \times 2 \times 1}{1000} \times \sqrt{4000} \times (12 \times 7.6) = 8.7 \text{ K}$$

which is greater than  $V_u = 3.47$  K. In normal loadings, one-way shear does not control.

- Calculate the total static moments in the long and short directions. In the long direction,

$$M_{0l} = \frac{q_u l_2^2 n_1^2}{8} = \frac{0.33}{8} \times 20(22.33)^2 = 411.4 \text{ K} \cdot \text{ft}$$



**Table 17.7** Design of Interior Flat-Plate Panel (Long Direction)

$M_0 = 411.4 \text{ K} \cdot \text{ft}$				
$M_n = 0.65M_0 = -267.4 \text{ K} \cdot \text{ft}$				
$M_p = +0.35M_0 = +144 \text{ K} \cdot \text{ft}$				
Long Direction	Column Strip		Middle Strip	
	Negative	Positive	Negative	Positive
Moment distribution (%)	75	60	25	40
$M_u$ (K · ft)	$0.75M_n = -201.6$	$0.6M_p = \pm 86.4$	$0.25M_n = -66.8$	$0.4M_p = \pm 57.16$
Width of strip $b$ (in.)	120	120	120	120
Effective depth $d$ (in.)	7.9	7.9	7.9	7.9
$R_u = \frac{M_u}{bd^2}$ (psi)	323	128	107	93
Steel ratio $\rho$ (%)	0.633	0.262	0.2	0.175
$A_s = \rho bd$ (in. <sup>2</sup> )	6.00	2.48	1.92	1.66
Min. $A_s = 0.0018bh_s$ (in. <sup>2</sup> )	1.94	1.94	1.94	1.94
Bars selected (straight)	20 no. 5	10 no. 5	10 no. 4	10 no. 4
Spacing $\leq 2h = 18$ in.	6 in.	12	12	12

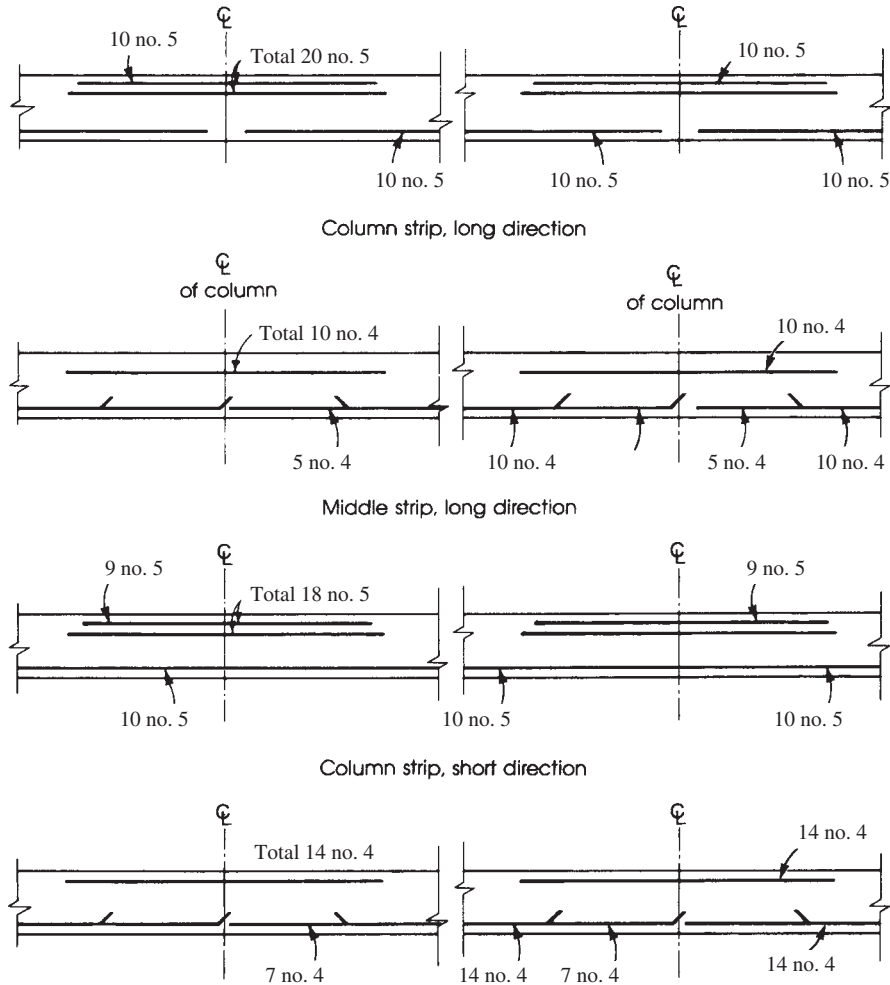
**Table 17.8** Design of Interior Flat-Plate Panel (Short Direction)

$M_0 = 333 \text{ K} \cdot \text{ft}$				
$M_n = 0.65M_0 = -216.5 \text{ K} \cdot \text{ft}$				
$M_p = +0.35M_0 = +116.5 \text{ K} \cdot \text{ft}$				
Short Direction	Column Strip		Middle Strip	
	Negative	Positive	Negative	Positive
Moment distribution (%)	75	60	25	40
$M_u$ (K · ft)	$0.75M_n = -162.4$	$0.6M_p = \pm 69.9$	$0.25M_n = -54.1$	$0.4M_p = \pm 46.16$
Width of strip $b$ (in.)	120	120	168	168
Effective depth $d$ (in.)	7.3	7.3	7.3	7.3
$R_u = \frac{M_u}{bd^2}$ (psi)	305	131	73	62
Steel ratio $\rho$ (%)	0.60	0.25	0.14	0.12
$A_s = \rho bd$ (in. <sup>2</sup> )	5.23	2.18	1.72	1.46
Min. $A_s = 0.0018bh_s$ (in. <sup>2</sup> )	1.94	1.94	2.72	2.72
Bars selected (straight)	18 no. 5	10 no. 5	14 no. 4	14 no. 4
Spacing $\leq 2h = 18$ in.	6.7	12	12	12

In the short direction,

$$M_{0s} = \frac{q_u l_1 l_2^2}{8} = \frac{0.33}{8} \times 24 \times (18.33)^2 = 333 \text{ K} \cdot \text{ft}$$

Because  $l_2 < l_1$ , the width of half a column strip in the long direction is  $0.25 \times 20 = 5$  ft, and the width of the middle strip is  $20 - 2 \times 5 = 10$  ft. The width of half the column strip in the short direction is 5 ft, and the width of the middle strip is  $24 - 2 \times 5 = 14$  ft. To calculate the effective depth,  $d$ , in each direction, assume that steel bars in the short direction are placed on top of the bars in the



**Figure 17.20** Example 17.3: Reinforcement details. For bar length, refer to Fig. 17.16.

long direction. Therefore,  $d(\text{longdirection}) = 9.0 - 0.75 - \frac{5}{16} = 7.9$  in. and  $d(\text{shortdirection}) = 9.0 - 0.75 - \frac{5}{8} - \frac{5}{16} = 7.3$  in. For practical applications, an average  $d = 9 - 1.5 = 7.5$  in. can be used for both directions.

The design procedure can be conveniently arranged in a table form, as in Tables 17.7 and 17.8.

The details for the bars selected for this interior slab are shown in Fig. 17.20 using the straight bar system. Minimum lengths of the bars must meet those shown in Fig. 17.16.

Straight bars and  $f_y = 60$  ksi steel bars are more often preferred by contractors.

$$\text{Maximum spacing} = \frac{\text{width of panel}}{\text{no. of bars}} = \frac{168}{14} = 12 \text{ in.}$$

occurs at the middle strip in the short direction; this spacing of 12 in. is adequate because it is less than  $2h = 18$  in. and less than 18 in. specified by the ACI Code. Note that all steel ratios are less than  $\rho_{\max} = 0.018$ . Thus  $\phi = 0.9$ .

**Example 17.4**

Using the direct design method, design an *exterior flat-plate* panel that has the same dimensions, loads, and concrete and steel strengths given in Example 17.3. No beams are used along the edges (Fig. 17.21).

**Solution**

1. Determine the minimum slab thickness using Table 17.1 for flat plates. From Example 17.1, a 9.0-in. slab thickness is adopted.
2. Calculate factored loads:  $W_u = 330$  psf. (See Example 17.3.)
3. Check one- and two-way shear (refer to Example 17.3 and Fig. 17.19).
  - a. Check punching shear at an interior column:  $V_u = 156.7 < \phi V_c = 158.6$  K.
  - b. Check one-way shear:  $V_u = 3.47$  K  $< \phi V_c = 8.7$  K.
  - c. Check punching shear at the exterior column:  $d = 7.6$  in.

$$x = 20 + \frac{d}{2} = 20 + \frac{7.6}{2} = 23.8 \text{ in.} = 1.98 \text{ ft}$$

$$y = 20 + d = 20 + 7.6 = 27.6 \text{ in.} = 2.30 \text{ ft}$$

$$b_0 = 2x + y = 75.2 \text{ in.}$$

$$V_u = \left[ 20 \left( 12 + \frac{10}{12} \right) - 1.98(2.30) \right] 0.33 = 83.2 \text{ K}$$

$$\phi V_c = \phi \left( 2 + \frac{4}{\beta} \right) \sqrt{f'_c} b_0 d$$

$$\beta = \frac{24}{20} = 1.2$$

$$= 0.75 \left( 2 + \frac{4}{1.2} \right) \times \frac{\sqrt{4000}}{1000} \times 75.2 \times 7.6$$

$$= 144 \text{ K}$$

$$\phi V_c = \phi \left( \frac{\alpha_s d}{b_0} + 2 \right) \sqrt{f'_c} b_0 d$$

$$= 0.75 \left( \frac{30 \times 7.6}{75.2} + 2 \right) \frac{\sqrt{4000}}{1000} \times 75.2 \times 7.6$$

$$= 136.4 \text{ K}$$

$$\phi V_c = \phi 4 \sqrt{f'_c} b_0 d = 108.4 \text{ K (controls)} > V_u$$

- d. Check punching shear at a corner column:  $d = 7.6$  in.

$$x = y = 20 + \frac{d}{2} = 23.8 \text{ in.} = 1.98 \text{ ft}$$

$$b_0 = x + y = 47.6 \text{ in.}$$

$$V_u = \left[ \left( 10 + \frac{10}{12} \right) \left( 12 + \frac{10}{12} \right) - (1.98)(1.98) \right] 0.33 = 44.6 \text{ K}$$

$$\phi V_c = \phi \left( 2 + \frac{4}{\beta} \right) \sqrt{f'_c} b_0 d$$

$$\beta = \frac{24}{20} = 1.2$$

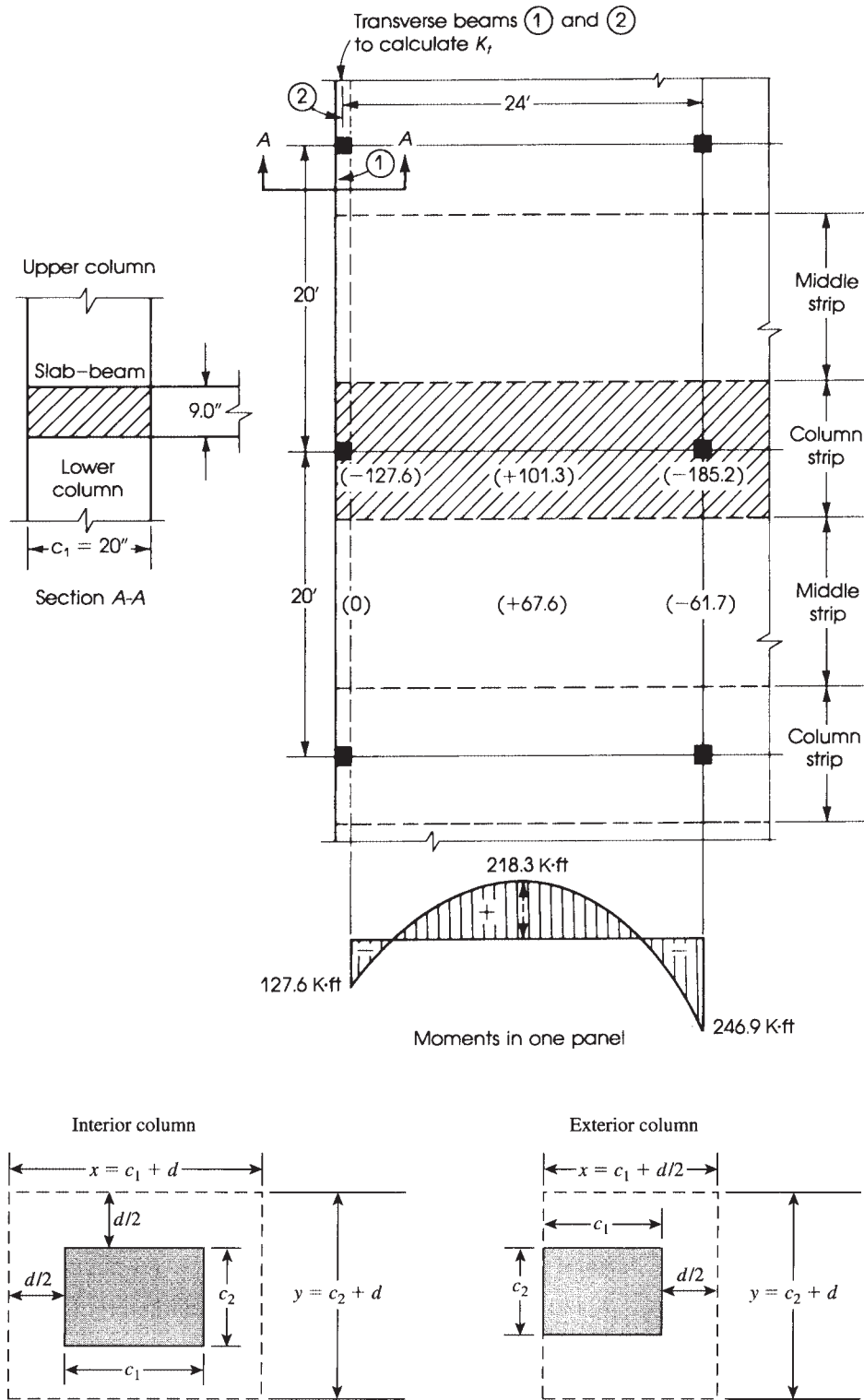


Figure 17.21 Example 17.4: Distribution of bending moments.

$$= 0.75 \left( 2 + \frac{4}{1.2} \right) \frac{\sqrt{4000}}{1000} \times 47.6 \times 7.6$$

$$= 91.5 \text{ K}$$

$$\phi V_c = \phi \left( \frac{\alpha_s d}{b_0} + 2 \right) \sqrt{f'_c} b_0 d$$

$$= 0.75 \left( \frac{20 \times 7.6}{47.6} + 2 \right) \frac{\sqrt{4000}}{1000} \times 47.6 \times 7.6$$

$$= 89.1 \text{ K}$$

$$\phi V_c = \phi 4 \sqrt{f'_c} b_0 d = 68.6 \text{ K (controls)} > V_u$$

4. Calculate the total static moments. From Example 17.3,

$$M_{0l} \text{ (long direction)} = 411.4 \text{ K} \cdot \text{ft} \quad d = 7.9 \text{ in.}$$

$$M_{0s} \text{ (short direction)} = 333 \text{ K} \cdot \text{ft} \quad d = 7.3 \text{ in.}$$

The width of the column strip is 120 in., and the width of the middle strip is 168 in.

5. Calculate the design moments in the long direction:  $l_1 = 24 \text{ ft}$ . (Refer to Table 17.5 or Fig. 17.15). The distribution of the total moment,  $M_{0l}$ , in the column and middle strips is computed as follows:

- a. Column strip:

$$\text{Interior negative moment} = -0.525M_0 = -0.525(411.4) = -216 \text{ K} \cdot \text{ft}$$

$$\text{Positive moment within span} = 0.312M_0 = 0.312(411.4) = +128.4 \text{ K} \cdot \text{ft}$$

$$\text{Exterior negative moment} = -0.26M_0 = -0.26(411.4) = -107 \text{ K} \cdot \text{ft}$$

- b. Middle strip:

$$\text{Interior negative moment} = -0.175M_0 = -0.175 \times 411.4 = -72 \text{ K} \cdot \text{ft}$$

$$\text{Positive moment within span} = 0.208M_0 = 0.208 \times 411.4 = +85.6 \text{ K} \cdot \text{ft}$$

$$\text{Exterior negative moment} = 0$$

6. Calculate the design moments in the short direction:  $l_s = 20 \text{ ft}$ . It will be treated as an interior panel because it is continuous on both sides. Referring to Table 17.4 or Fig. 17.15, the distribution of the total moment,  $M_{0s}$ , in the column and middle strips is computed as follows:

- a. Column strip:

$$\text{Negative moment} = 0.49M_0 = -0.49(333) = -163.2 \text{ K} \cdot \text{ft}$$

$$\text{Positive moment} = +0.21M_0 = +0.21(333) = +70.0 \text{ K} \cdot \text{ft}$$

- b. Middle strip:

$$\text{Negative moment} = -0.16M_0 = -0.16(333) = -53.3 \text{ K} \cdot \text{ft}$$

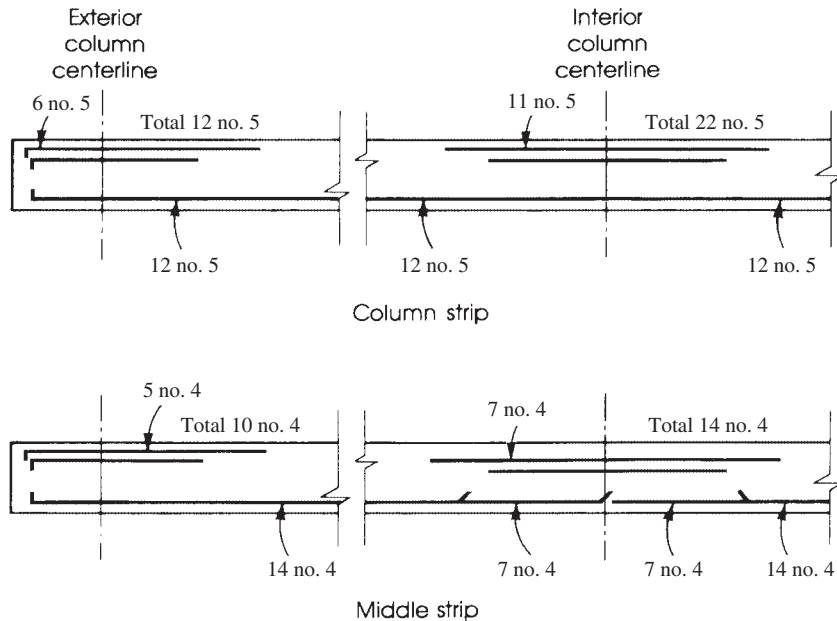
$$\text{Positive moment} = +0.14M_0 = +0.14(333) = +46.6 \text{ K} \cdot \text{ft}$$

The design procedure can be conveniently arranged in Table 17.9. The details for bars selected are shown in Fig. 17.22 using the straight-bar system in the long direction. Details of reinforcement in the short direction will be similar to Fig. 17.20 using the bars chosen in Table 17.9.

Note that all steel ratios are less than  $\rho_{\max} = 0.018$ . Thus  $\phi = 0.9$ .

**Table 17.9** Design of Exterior Flat-Plate Panel for Example 17.4 ( $d = 7.9$  in.)

	Column Strip			Middle Strip		
	Exterior	Positive	Interior	Exterior	Positive	Interior
<b>Long direction</b>						
$M_u$ (K · ft)	-107.06	±128.4	-216.0	0	±85.6	-72.0
$b$ (in.)	120	120	120	120	120	120
$R_u = \frac{M_u}{bd^2}$ (psi)	172	206	346	0	138	116
Steel ratio $\rho$ (%)	0.33	0.4	0.682	0	0.262	0.22
$A_s = \rho bd$	3.11	3.75	6.47	0	2.48	2.10
Min. $A_s = 0.0018bh_s$	1.94	1.94	1.94	1.94	1.94	1.94
Bars selected (straight)	12 no. 5	12 no. 5	22 no. 5	10 no. 4	14 no. 4	14 no. 4
Spacing 18 in.	10	10	5.5	12	8.5	8.5
<b>Short direction</b>						
$M_u$ (K · ft)	-163.2	—	±70.0	-53.3	—	±46.6
Width of strip $b$ (in.)	120	—	120	168	—	168
$d$ (in.)	7.3	—	7.3	7.3	—	7.3
$R_u = \frac{M_u}{bd^2}$ (psi)	306	—	131	71	—	63
Steel ratio $\rho$ (%)	0.6	—	0.25	0.133	—	0.12
$A_s = \rho bd$ (in. <sup>2</sup> )	5.26	—	2.20	1.63	—	1.47
Min. $A_s = 0.0018bh_s$	1.94	—	1.94	2.72	—	2.72
Bars selected (straight)	18 no. 5	—	8 no. 5	14 no. 4	—	14 no. 4
Spacing 18 in.	6.67	—	15	12	—	12



**Figure 17.22** Example 17.4: Reinforcement details (longitudinal direction). For bar lengths, refer to Fig. 17.16.

**Example 17.5**

Repeat Example 17.4 using the modified stiffness method. (Similar calculations are needed for the equivalent frame method, Section 17.12.)

**Solution**

- Steps 1 through 4 will be the same as in Example 17.4.
- Calculate the equivalent column stiffness,  $K_{ec}$ :

$$\frac{1}{K_{ec}} = \frac{1}{\sum K_c} + \frac{1}{K_t}$$

It can be assumed that the part of the slab strip between exterior columns acts as a beam resisting torsion. The section of the slab-beam is 20 in. (width of the column)  $\times$  9.0 in. (thickness of the slab), as shown in Fig. 17.21.

- Determine the torsional stiffness,  $K_t$ , from Eq. 17.20:

$$C = \left(1 - 0.63 \frac{x}{y}\right) \frac{x^3 y}{3}$$

For  $x = 9$  in.,  $y = 20$  in.,

$$C = \left(1 - 0.63 \times \frac{9}{20}\right) \frac{9^3 \times 20}{3} = 3482 \text{ in.}^4$$

$$K_t = \frac{9E_c C}{l_2(1 - c_2/l_2)^3} = \frac{9E_c \times 3482}{(20 \times 12)[1 - 20/(20 \times 12)]^3} = 170E_c$$

For the two adjacent slabs (on both sides of the column) acting as transverse beams,

$$K_t = 2 \times 170E_c = 340E_c$$

- Calculate the column stiffness,  $K_c$ ; the column height  $L_c = 12$  ft:

$$K_c = \frac{4E_c I_c}{L_c} = \frac{4E_c}{12 \times 12} \times \frac{(20)^4}{12} = 370.4E_c$$

For two columns above and below the floor slab,

$$K_c = 2 \times 370.4E_c = 740.8E_c$$

- Calculate  $K_{ec}$ :

$$\frac{1}{K_{ec}} = \frac{1}{740.8E_c} + \frac{1}{340E_c}$$

To simplify the calculations, multiply by  $1000 E_c$ :

$$\frac{1000E_c}{K_{ec}} = \frac{1000}{740.8} + \frac{1000}{340} = 4.29 \quad K_{ec} = 233E_c$$

- Calculate slab stiffness and the ratio  $\alpha_{ec}$ :

$$K_s = \frac{4E_c I_s}{l_1} \quad h = 9 \text{ in.} \quad l_2 = 20 \text{ ft} \quad I_s = \frac{l_2 h^3}{12}$$

$$K_s = \frac{4E_c}{24 \times 12} \times \frac{(20 \times 12)(9.0)^3}{12} = 202.5E_c$$

$$\alpha_{ec} = \frac{K_{ec}}{\sum(K_s + K_b)}$$

$$K_b = 0 \text{ (no beams are provided)}$$

Thus

$$\alpha_{ec} = \frac{233E_c}{202.5E_c} = 1.15$$

Let

$$Q = \left(1 + \frac{1}{\alpha_{ec}}\right) = 1 + \frac{1}{1.15} = 1.87$$

4. Calculate the design moments in the long direction:  $l_1 = 24$  ft. The distribution of moments in one panel is shown in Fig. 17.18. The interior negative moment is

$$M_{nt} = \left[0.75 - \frac{0.10}{Q}\right] M_{Ol} = \left(0.75 - \frac{0.10}{1.87}\right) (411.4) = -286.6 \text{ K} \cdot \text{ft}$$

The positive moment is

$$\begin{aligned} M_p &= \left(0.63 - \frac{0.28}{Q}\right) M_{Ol} \\ &= \left(0.63 - \frac{0.28}{1.87}\right) (411.4) = 197.6 \text{ K} \cdot \text{ft} \end{aligned}$$

The exterior negative moment is

$$M_{ne} = \frac{0.65}{Q} (M_{Ol}) = \frac{0.65}{1.87} (411.4) = -143.0 \text{ K} \cdot \text{ft}$$

5. Calculate the distribution of panel moments in the transverse direction to column and middle strips. The moments  $M_{ni}$ ,  $M_p$ , and  $M_{ne}$  are distributed as follows (refer to Table 17.6):

- a. The interior moment ( $M_{ni}$ ) =  $-286.6 \text{ K} \cdot \text{ft}$  is distributed 75% for the column strip and 25% for the middle strip.

$$\text{Column strip} = 0.75(-286.6) = -215 \text{ K} \cdot \text{ft}$$

$$\text{Middle strip} = 0.25(-286.6) = -71.6 \text{ K} \cdot \text{ft}$$

- b. The positive moment,  $M_p = 197.6 \text{ K} \cdot \text{ft}$ , is distributed 60% for the column strip and 40% for the middle strip.

$$\text{Column strip} = 0.6(197.6) = 118.5 \text{ K} \cdot \text{ft}$$

$$\text{Middle strip} = 0.4(197.6) = 79.1 \text{ K} \cdot \text{ft}$$

- c. The exterior negative moment,  $M_{ne} = -143 \text{ K} \cdot \text{ft}$ , is distributed according to Table 17.5:

$$\beta_t = \frac{E_c C}{2E_c I_s} = \frac{C}{2I_s}$$

The concrete of slab and column are the same.

$$I_s = (20 \times 12) \frac{(9.0)^3}{12} = 14,580 \text{ in.}^4$$

$$\beta_t = \frac{3482}{2 \times 14,580} = 0.119$$

$$\alpha_{f_1} = \frac{E_{cb} I_b}{E_{cs} I_s} = 0 \quad \alpha_{f_1} \frac{l_2}{l_1} = 0 \quad \frac{l_2}{l_1} = 0.83$$

From Table 17.5 and by interpolation between  $\beta_t = 0$  (percentage = 100%) and  $\beta_t = 2.5$  (percentage = 100%) for  $\beta_t = 0.119$ , the percentage is 99%. The exterior negative moment in the column strip is  $0.99(-143.10) = -142 \text{ K} \cdot \text{ft}$  and in the middle strip, it is  $-1.10 \text{ K} \cdot \text{ft}$ . It is practical to consider that the column strip carries in this case 100% of  $M_{ne} = -143 \text{ K} \cdot \text{ft}$ .



6. Determine the reinforcement required in the long direction in a table form similar to Example 17.4. Results will vary slightly from those of Table 17.8.
7. Comparison of results between Examples 17.4 and 17.5 shows that the exterior moment in the column strip ( $-143 \text{ K} \cdot \text{ft}$ ) is greater than that calculated in Example 17.4 ( $-107 \text{ K} \cdot \text{ft}$ ) by about 34%, whereas the positive moment ( $\pm 118.15$ ) is reduced by about 8% (relative to  $\pm 128.14$ ). Other values are almost compatible.

### Example 17.6

Design an interior panel of the two-way slab floor system shown in Fig. 17.7. The floor consists of six panels in each direction, with a panel size of  $24 \times 20 \text{ ft}$ . All panels are supported on  $20 \times 20 \text{ in.}$  columns,  $12 \text{ ft}$  long. The slabs are supported by beams along the column lines with the cross sections shown in the figure. The service live load is to be taken as  $100 \text{ psf}$ , and the service dead load consists of  $22 \text{ psf}$  of floor finish in addition to the slab weight. Use normal-weight concrete with  $f'_c = 3 \text{ ksi}$ ,  $f_y = 60 \text{ ksi}$ , and the direct design method.

### Solution

1. The limitations required by the ACI Code are met. Determine the minimum slab thickness using Eqs. 17.1 and Eqs. 17.2. The slab thickness has been already calculated in Example 17.2, and a  $7.0 \text{ in.}$  slab can be adopted. Generally, the slab thickness on a floor system is controlled by a corner panel, as the calculations of  $h_{\min}$  for an exterior panel give greater slab thickness than for an interior panel.
2. Calculate factored loads:

$$q_D = 22 + \text{weight of slab} = 22 + \frac{7}{12} \times 150 = 109.5 \text{ psf}$$

$$q_u = 1.2(109.5) + 1.6(100) = 292 \text{ psf}$$

3. The shear stresses in the slab are not critical. The critical section is at a distance  $d$  from the face of the beam. For a 1-ft width:

$$\begin{aligned} V_u &= q_u \left( 10 - \frac{1}{2} \text{beam width} - d \right) \\ &= 0.292 \left( 10 - \frac{16}{2 \times 12} - \frac{6}{12} \right) = 2.58 \text{ K} \end{aligned}$$

$$\phi V_c = \phi(2\lambda\sqrt{f'_c})bd = \frac{0.75 \times 2 \times 1 \times \sqrt{3000} \times 12 \times 6}{1000} = 6.3 \text{ K} > V_u$$

4. Calculate the total static moments in the long and short directions:

$$M_{0l} = \frac{q_u}{8} l_2 (l_{n1})^2 = \frac{0.292}{8} (20)(22.33)^2 = 364.0 \text{ K} \cdot \text{ft}$$

$$M_{0s} = \frac{q_u}{8} l_1 (l_{n2})^2 = \frac{0.292}{8} (24)(18.33)^2 = 294.3 \text{ K} \cdot \text{ft}$$

5. Calculate the design moments in the long direction:  $l_1 = 24 \text{ ft}$ .

- a. Distribution of moments in one panel:

$$\text{Negative moment } (M_n) = 0.65M_{0l} = 0.65 \times 364 = -236.6 \text{ K} \cdot \text{ft}$$

$$\text{Positive moment } (M_p) = 0.35M_{0l} = 0.35 \times 364 = 127.4 \text{ K} \cdot \text{ft}$$

- b. Distributions of panel moments in the transverse direction to the beam, column, and middle strips are as follows:

$$\frac{l_2}{l_1} = \frac{20}{24} = 0.83 \quad \alpha_{f_1} = \alpha_s = \frac{EI_b}{EI_s} = 3.27 \quad (\text{from Example 17.2})$$

$$\alpha_{f_1} \frac{l_2}{l_1} = 3.27 \times 0.83 = 2.71 > 1.0$$

- c. Distribute the negative moment,  $M_n$ . The portion of the interior negative moment to be resisted by the column strip is obtained from Table 17.3 by interpolation and is equal to 80% (for  $l_2/l_1 = 0.83$  and  $\alpha_{f_1} (l_2/l_1) > 1.0$ ).

$$\text{Column strip} = 0.8M_n = 0.8 \times 236.16 = -189.13 \text{ K} \cdot \text{ft}$$

$$\text{Middle strip} = 0.2M_n = 0.2 \times 236.16 = -47.13 \text{ K} \cdot \text{ft}$$

Because  $\alpha_{f_1} (l_2/l_1) > 1.0$ , the ACI Code, Section 8.10.5.7.1, indicates that 85% of the moment in the column strip is assigned to the beam and the balance of 15% is assigned to the slab in the column strip.

$$\text{Beam} = 0.85 \times 189.3 = -160.9 \text{ K} \cdot \text{ft}$$

$$\text{Column strip} = 0.15 \times 189.3 = -28.4 \text{ K} \cdot \text{ft}$$

$$\text{Middle strip} = -47.3 \text{ K} \cdot \text{ft}$$

- d. Distribute the positive moment,  $M_p$ . The portion of the interior positive moment to be resisted by the column strip is obtained from Table 17.3 by interpolation and is equal to 80% (for  $l_2/l_1 = 0.83$  and  $\alpha_{f_1} (l_2/l_1) > 1.0$ ).

$$\text{Column strip} = 0.8M_p = 0.8 \times 127.4 = +101.9 \text{ K} \cdot \text{ft}$$

$$\text{Middle strip} = 0.2M_p = 0.2 \times 127.4 = +25.5 \text{ K} \cdot \text{ft}$$

Since  $\alpha_{f_1} (l_2/l_1) > 1.0$ , 85% of the moment in the column strip is assigned to the beam and the balance of 15% is assigned to the slab in the column strip:

$$\text{Beam} = 0.85 \times 101.9 = +86.6 \text{ K} \cdot \text{ft}$$

$$\text{Column strip} = 0.15 \times 101.9 = +15.3 \text{ K} \cdot \text{ft}$$

$$\text{Middle strip} = +25.5 \text{ K} \cdot \text{ft}$$

Moment details are shown in Fig. 17.23.

6. Calculate the design moment in the short direction: span = 20 ft. The procedure is similar to step 5.

$$\text{Negative moment } (M_n) = 0.65M_{0s} = 0.65 \times 294.3 = -191.3 \text{ K} \cdot \text{ft}$$

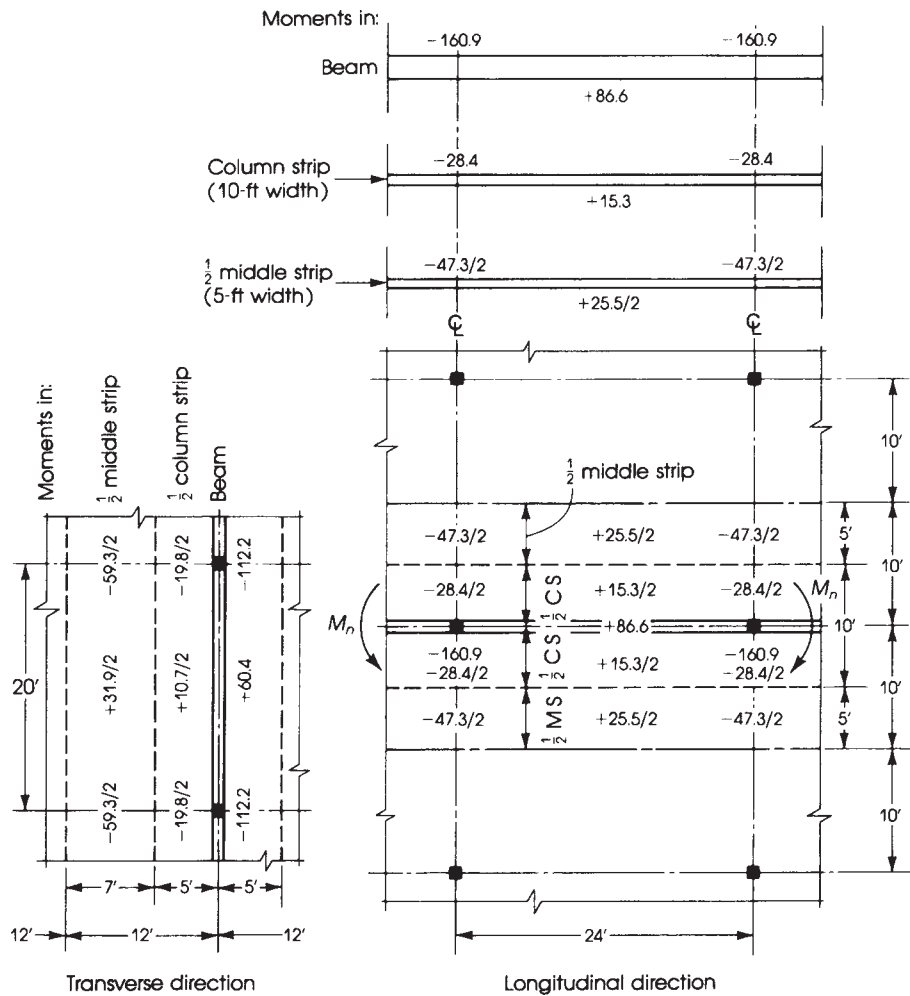
$$\text{Positive moment } (M_p) = 0.35M_{0s} = 0.35 \times 294.3 = +103.0 \text{ K} \cdot \text{ft}$$

Distribution of  $M_n$  and  $M_p$  to beam, column, and middle strips:

$$\frac{l_2}{l_1} = \frac{24}{20} = 1.2 \quad \alpha_{f_2} = \alpha_s = \frac{EI_b}{EI_s} = 2.72 \quad (\text{from Example 17.2})$$

$$\alpha_{f_2} \frac{l_2}{l_1} = 2.72 \times 1.2 = 3.26 > 1.0$$

The percentages of the column strip negative and positive moments are obtained from Table 17.3 by interpolation. (For  $l_2/l_1 = 1.12$  and  $\alpha_{f_2} (l_2/l_1) > 1.0$ , the percentage is 69%.)



**Figure 17.23** Example 17.6: Interior slab with beams. All moments are in K · ft.

$$\text{Column strip negative moment} = 0.69M_n = 0.69 \times 191.3 = -132 \text{ K} \cdot \text{ft}$$

$$\text{Middle strip negative moment} = 0.31M_n = 0.31 \times 191.3 = -59.3 \text{ K} \cdot \text{ft}$$

Since  $\alpha_f(l_2/l_1) > 1.0$ , 85% of  $-132 \text{ K} \cdot \text{ft}$  is assigned to the beam. Therefore,

$$\text{Beam negative moment} = 0.85 \times 132 = -112.2 \text{ K} \cdot \text{ft}$$

$$\text{Column strip positive moment} = 0.15 \times 132 = -19.8 \text{ K} \cdot \text{ft}$$

$$\text{Beam positive moment} = (0.85)(0.69 \times 103.0) = +60.4 \text{ K} \cdot \text{ft}$$

$$\text{Column strip positive moment} = (0.15)(0.69 \times 103.0) = +10.7 \text{ K} \cdot \text{ft}$$

$$\text{Middle strip positive moment} = (1 - 0.69)(103.10) = \pm 31.19 \text{ K} \cdot \text{ft}$$

7. The steel reinforcement required and number of bars is shown in Table 17.10. Note all steel ratios are less than  $\rho_{\max} = 0.0135$ . Thus,  $\phi = 0.9$ .

**Table 17.10** Design of an Interior Two-Way Slab with Beams

	Column Strip		Middle Strip	
<b>Long direction</b>				
$M_u$ (K · ft)	-28.14	±15.13	-47.13	±25.15
Width of strip (in.)	120	120	120	120
Effective depth (in.)	6.0	6.0	6.0	6.0
$R_u = \frac{M_u}{bd^2}$ (psi)	79	43	132	71
Steel ratio $\rho$	0.0016	Low	0.0026	0.0015
$A_s = \rho bd$ (in. <sup>2</sup> )	1.15	Low	1.87	1.08
Min. $A_s = 0.0018bh$ (in. <sup>2</sup> )	1.52	1.52	1.52	1.52
Selected bars	8 no. 4	8 no. 4	10 no. 4	8 no. 4
<b>Short direction</b>				
$M_u$ (K · ft)	-19.18	±10.17	-59.13	±31.19
Width of strip (in.)	120	120	168	168
Effective depth (in.)	5.5	5.5	5.5	5.5
$R_u = \frac{M_u}{bd^2}$ (psi)	65	35	196	105
Steel ratio $\rho$	Low	Low	0.0039	0.002
$A_s = \rho bd$ (in. <sup>2</sup> )	Low	Low	3.60	1.85
Min. $A_s = 0.0018bh$ (in. <sup>2</sup> )	1.52	1.52	2.10	2.10
Selected bars	8 no. 4	8 no. 4	18 no. 4	10 no. 4

**Example 17.7**

Using the direct design method, determine the negative and positive moments required for the design of the exterior panel (no. 2) of the two-way slab system with beams shown in Fig. 17.7. Use the loads and the data given in Example 17.6.

**Solution**

- Limitations required by the ACI Code are satisfied in this problem. Determine the minimum slab thickness,  $h$ , using Eqs. 17.1 and 17.2 and the following steps: Assume  $h = 7.10$  in. The sections of the interior and exterior beams are shown in Fig. 17.7. Note that the extension of the slab on each side of the beam  $x = y = 15$  in.
- a. The moments of inertia for the *interior* beams and slabs were calculated earlier in Example 17.2:

$$I_b \text{ (in both directions)} = 22,453 \text{ in.}^4$$

$$I_s \text{ (in the long direction)} = 6860 \text{ in.}^4$$

$$I_s \text{ (in the short direction)} = 8232 \text{ in.}^4$$

- b. Calculate  $I_b$  and  $I_s$  for the *edge* beam and end slab.

$$\begin{aligned} I_b(\text{edge beam}) &= \left[ \frac{27}{12}(7)^3 + (27 \times 7)(5.37)^2 \right] + \left[ \frac{12}{12}12(15)^3 + (12 \times 15)(5.63)^2 \right] \\ &= 15,302 \text{ in.}^4 \end{aligned}$$

Calculate  $I_s$  for the end strip parallel to the edge beam, which has a width =  $\frac{24}{2}$  ft +  $\frac{1}{2}$  columnwidth =  $12 + \frac{10}{12} = 12.83$  ft.

$$I_s \text{ (endslab)} = \frac{12.83 \times 12}{12}(7)^3 = 4401 \text{ in.}^4$$

3. a. Calculate  $\alpha_f$  ( $\alpha_f = EI_b/EI_s$ ):

$$\alpha_l \text{ (long direction)} = \frac{22,453}{6860} = 3.27$$

$$\alpha_s \text{ (short direction)} = \frac{22,453}{8232} = 2.72$$

$$\alpha \text{ (edge beam)} = \frac{15,302}{4401} = 3.48$$

$$\text{Average } \alpha = \alpha_{\text{fm}} = \frac{3.27 + 2.72 \times 2 + 3.48}{4} = 3.05$$

- b.  $\beta$  = ratio of long to short clear span.

$$\frac{22.33}{18.33} = 1.22$$

- c. Calculate  $h$ :

$$\text{Min. } h = \frac{(22.33 \times 12)(0.8 + 60,000/200,000)}{36 + 9(1.22)} = 6.3 \text{ in.}$$

Use  $h = 7 \text{ in.} > 3.5 \text{ in.}$  (minimum code limitations).

4. Calculate factored loads:

$$q_u = 292 \text{ psf} \quad (\text{from Example 17.6})$$

5. Calculate total static moments:

$$M_{0l} = 364.0 \text{ K} \cdot \text{ft} \quad M_{0s} = 294.3 \text{ K} \cdot \text{ft} \quad (\text{from previous example})$$

6. Calculate the design moments in the short direction (span = 20 ft): Because the slab is continuous in this direction, the moments are the same as those calculated in Example 17.23 and shown in Fig. 17.23 for an interior panel.
7. Calculate the moments in one panel using the coefficients given in Table 17.2 or Fig. 17.14 (Case 3):

$$\text{Interior negative moment } (M_{\text{nt}}) = 0.7M_0 = 0.7 \times 364 = -254.8 \text{ K} \cdot \text{ft}$$

$$\text{Positive moment within span } (M_p) = 0.57M_0 = 0.57 \times 364 = +207.5 \text{ K} \cdot \text{ft}$$

$$\text{Exterior negative moment } (M_{\text{ne}}) = 0.16M_0 = 0.16 \times 364 = -58.2 \text{ K} \cdot \text{ft}$$

*Note:* If the modified stiffness method is used, then  $C = 9528$ ,  $K_l = 1520 E_c$ ,  $K_c = 370 E_c$ ,  $K_b = 312 E_c$ ,  $K_s = 95 E_c$ ,  $K_{\text{ec}} = 498 E_c$ , and  $\alpha_{\text{ec}} = 1.22$ . The interior negative moment becomes  $-253.13 \text{ K} \cdot \text{ft}$  (same as before). The positive moment becomes  $-173.19 \text{ K} \cdot \text{ft}$  (16% decrease) and the exterior moment becomes  $-128.16 \text{ K} \cdot \text{ft}$  (220% increase).

8. Distribute the panel moments to beam, column, and middle strips:

$$\frac{l_2}{l_1} = \frac{20}{24} = 0.83 \quad \alpha_{f1} = \alpha_s = 3.27$$

$$\alpha_{f1} \frac{l_2}{l_1} = 3.27 \times 0.83 = 2.71 > 1.0$$

Calculate  $C$ :

$$C = \sum \left( 1 - 0.63 \frac{x}{y} \right) \frac{x^3 y}{3}$$

Divide the section of the edge beam into two rectangles in such a way as to obtain maximum  $C$ . Use for a beam section 12 by 22 in.,  $x_1 = 12 \text{ in.}$ ,  $y_1 = 22 \text{ in.}$ , and a slab section 7 by 15 in.,  $x_2 = 7 \text{ in.}$ ,

and  $y_2 = 15$  in.

$$C = \left(1 - 0.63 \times \frac{12}{22}\right) \left(\frac{12^3 \times 22}{3}\right) + \left(1 - 0.63 \times \frac{7}{15}\right) \left(\frac{7^3 \times 15}{3}\right)$$

$$= 9528 \text{ in.}^4$$

$$\beta_t = \frac{E_{cb} C}{2E_{cs} I_s} = \frac{9528}{2 \times 6860} = 0.69$$

- a. Distribute the interior negative moment,  $M_{ni}$ : Referring to Table 17.5 and by interpolation, the percentage of moment assigned to the column strip (for  $l_2/l_1 = 0.83$  and  $\alpha_{f1} l_2/l_1 > 1.0$  is 80%).

$$\text{Column strip} = 0.8 \times 254.8 = -203.8 \text{ K} \cdot \text{ft}$$

$$\text{Middle strip} = 0.2 \times 254.8 = -51.0 \text{ K} \cdot \text{ft}$$

Because  $\alpha_{f1} l_2/l_1 > 1.0$ , 85% of the moment in the column strip is assigned to the beam. Therefore,

$$\text{Beam} = 0.85 \times 203.8 = -173.3 \text{ K} \cdot \text{ft}$$

$$\text{Column strip} = 0.15 \times 203.8 = -30.6 \text{ K} \cdot \text{ft}$$

$$\text{Middle strip} = -51.0 \text{ K} \cdot \text{ft}$$

- b. Distribute the positive moment,  $M_p$ : Referring to Table 17.5 and by interpolation, the percentage of moment assigned to the column strip is 80% (85% of this value is assigned to the beam). Therefore,

$$\text{Beam} = (0.85)(0.8 \times 207.5) = +141.1 \text{ K} \cdot \text{ft}$$

$$\text{Column strip} = (0.15)(0.8 \times 207.5) = 24.9 \text{ K} \cdot \text{ft}$$

$$\text{Middle strip} = 0.2 \times 207.5 = +41.5 \text{ K} \cdot \text{ft}$$

- c. Distribute the exterior negative moment,  $M_{ne}$ : Referring to Table 17.5 and by interpolation, the percentage of moment assigned to the column strip (for  $l_2/l_1 = 0.83$ ,  $\alpha_{f1} l_2/l_1 > 1.0$ , and  $\beta_t = 0.69$ ) is 94%, and 85% of the moment is assigned to the beam. Therefore,

$$\text{Beam} = (0.85)(0.94 \times 58.2) = -46.5 \text{ K} \cdot \text{ft}$$

$$\text{Column strip} = (0.15)(0.94 \times 58.2) = -8.2 \text{ K} \cdot \text{ft}$$

$$\text{Middle strip} = 0.06 \times 58.2 = -3.5 \text{ K} \cdot \text{ft}$$

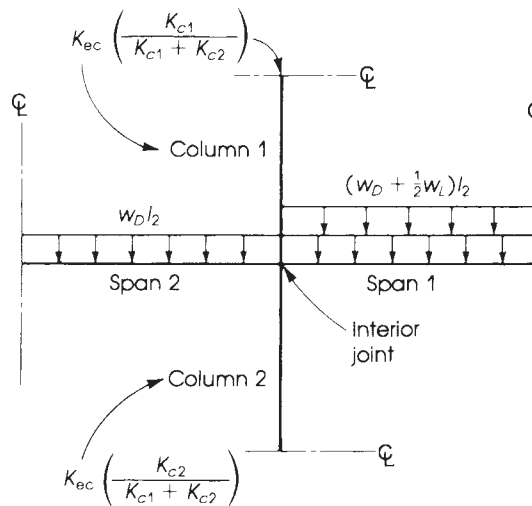
## 17.9 DESIGN MOMENTS IN COLUMNS

When the analysis of the equivalent frames is carried out by the direct design method, the moments in columns due to the unbalanced loads on adjacent panels are obtained from the following equation, which is specified by the ACI Code, Section 8.10.7.2:

$$M_u = 0.07[(q_{Du} + 0.5q_{Lu})l_2l_n^2 - q'_{Du}l_2'(l'_n)^2] \quad (17.22a)$$

If the modified stiffness method using  $K_{ec}$  and  $\alpha_{ec}$  is used, then the moment  $M_u$  is computed as follows:

$$M_u = \frac{0.08[(q_{Du} + 0.5q_{Lu})l_2l_n^2 - q'_{Du}l_2'(l'_n)^2]}{1 + 1/\alpha_{ec}} \quad (17.22b)$$



**Figure 17.24** Interior column loading.

where

$$\begin{aligned} q_{Du}, q_{Lu} &= \text{factored dead and live loads on longer span} \\ q'_{Du} &= \text{factored dead load on shorter span} \\ l_n, l'_n &= \text{length of longer and shorter spans, respectively} \end{aligned}$$

$$\alpha_{ec} = \frac{K_{ec}}{\sum(K_s + K_b)} \quad (\text{Eq. 17.21})$$

The moment in Eq. 17.22 should be distributed between the columns above and below the slab at the joint in proportion to their flexural stiffnesses (Fig. 17.24). For equal spans  $l_2 = l'_2$  and  $l_n = l'_n$ ,

$$M_u = \begin{cases} 0.07 (0.5q_{Lu}l_n^2) & (17.23a) \\ \frac{0.08(0.5q_{Lu}l_n^2)}{(1 + 1/\alpha_{ec})} & (17.23b) \end{cases}$$

The development of these equations is based on the assumption that half the live load acts on the longer span, whereas the dead load acts on both spans. Equation 17.22 can also be applied to an exterior column by assuming the shorter span length is 0 (Fig. 17.25).

## 17.10 TRANSFER OF UNBALANCED MOMENTS TO COLUMNS

### 17.10.1 Transfer of Moments

In the analysis of an equivalent frame in a building, moments develop at the slab–column joints due to lateral loads, such as wind, earthquakes, or unbalanced gravity loads, causing unequal moments in the slab on opposite sides of columns. A fraction of the unbalanced moment in the slabs must be transferred to the columns by flexure, and the balance must be transferred by vertical shear acting on the critical sections for punching shear. Approximately 60% of the moment transferred to both ends of the column at a joint is transferred by flexure, and the remaining 40% is transferred by

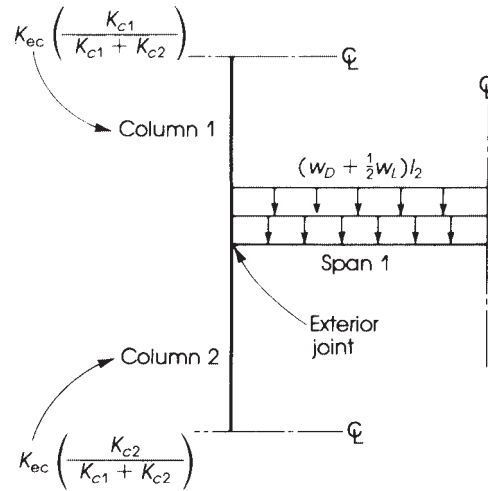


Figure 17.25 Exterior column loading.

eccentric shear (or torque) at the section located at  $d/2$  from the face of the column [14, 15]. The ACI Code, Section 8.4.2.3, states that the fraction of the unbalanced moment transferred by flexure  $M_f$  at a slab–column connection is determined as follows:

$$M_f = \gamma_f M_u \quad (17.24)$$

$$\gamma_f = \frac{1}{1 + \left( \frac{2}{3} \sqrt{\frac{c_1 + d}{c_2 + d}} \right)} = \frac{1}{1 + \left( \frac{2}{3} \right) \sqrt{\frac{b_1}{b_2}}} \quad (17.25)$$

and the moment transferred by shear is

$$M_v = (1 - \gamma_f) M_u = M_u - M_f \quad (17.26)$$

where  $c_1$  and  $c_2$  are the lengths of the two sides of a rectangular or equivalent rectangular column,  $b_1 = c_1 + d$ , and  $b_2 = c_2 + d$ . When  $c_1 = c_2$ ,  $M_f = 0.6 M_u$ , and  $M_v = 0.4 M_u$ .

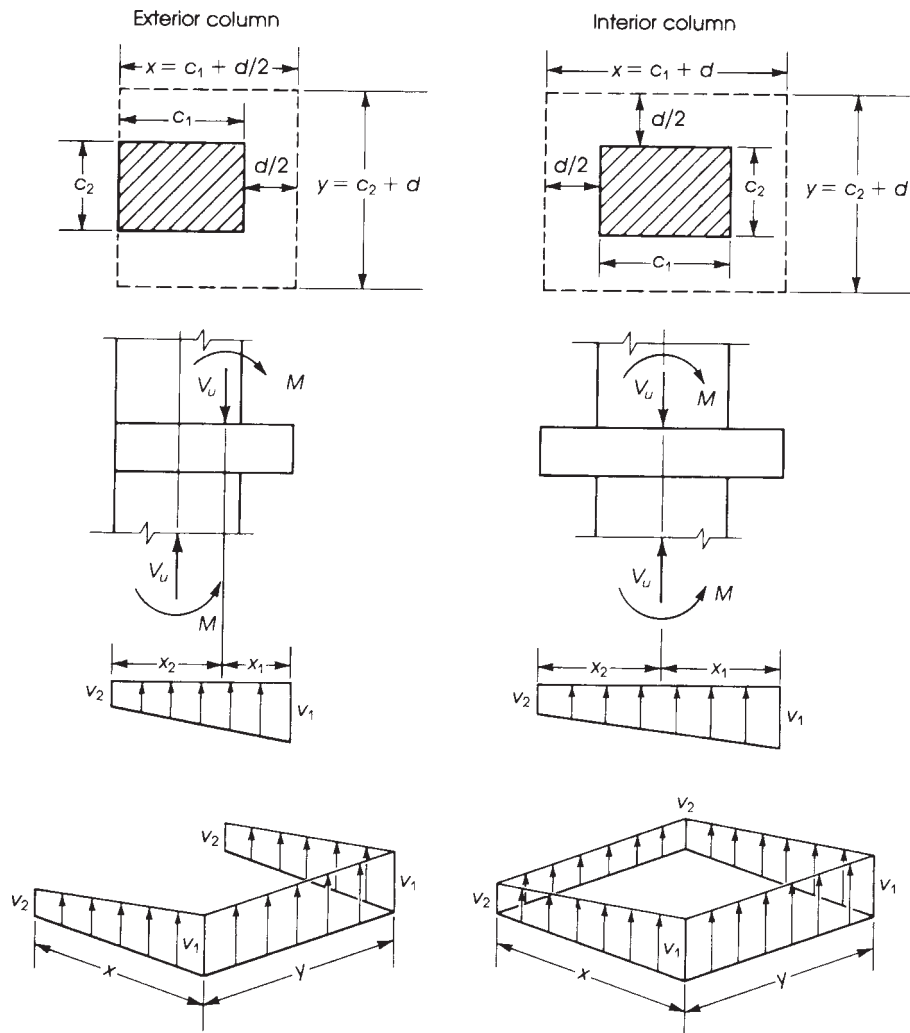
### 17.10.2 Concentration of Reinforcement Over the Column

For a direct transfer of moment to the column, it is necessary to concentrate part of the steel reinforcement in the column strip within a specified width over the column. The part of the moment transferred by flexure,  $M_f$ , is considered acting through a slab width equal to the transverse column width  $c_2$  plus  $1.5h$  on each side of the column or to the width  $(c_2 + 3h)$  (ACI Code, Section 8.4.2.3.3). Reinforcement can be concentrated over the column by closer spacing of bars or the use of additional reinforcement.

### 17.10.3 Shear Stresses Due to $M_v$

The shear stresses produced by the portion of the unbalanced moment,  $M_v$ , must be combined with the shear stresses produced by the shearing force,  $V_u$ , due to vertical loads. Both shear stresses are





**Figure 17.26** Shear stresses due to  $V_u$  and  $M$ .

assumed to be acting around a periphery plane located at a distance  $d/2$  from the face of the column [16], as shown in Fig. 17.26. The equation for computing the shear stresses is

$$v_{1,2} = \frac{V_u}{A_c} \pm \frac{M_v C}{J_c} \tag{17.27}$$

where

$A_c$  = area of critical section around column

$J_c$  = polar moment of inertia of areas parallel to applied moment in addition to that of end area about centroidal axis of critical section

For an interior column,

$$A_c = 2d(x + y) \tag{17.28}$$

and

$$J_c = \frac{d}{2} \left( \frac{x^3}{3} + x^2y \right) + \frac{xd^3}{6} \quad (17.29)$$

For an exterior column,

$$A_c = d(2x + y) \quad (17.30)$$

and

$$J_c = \frac{2dx^3}{3} + (2x + y)dx_1^2 - \left( 2dx^2x_1 - \frac{yd^3}{12} \right) \quad (17.31)$$

where  $x$ ,  $x_1$ , and  $y$  are as shown in Fig. 17.26. The maximum shear stress,  $v_1 = V_u/A_c + M_v C/J_c$ , must be less than  $\phi(4\sqrt{f'_c})$ ; otherwise, shear reinforcement should be provided.

### Example 17.8

Determine the moments at the exterior and interior columns in the long direction of the flat plate in Example 17.4.

#### Solution

1. Find the exterior column moment. From Examples Example 17.4 and Example 17.5,

$$q_{Du} = (136.5)(1.2) = 0.16 \text{ ksf}$$

$$0.5q_{Lu} = 0.5 \times (1.6 \times 100) = 80 \text{ psf}$$

$$l_2 = l'_2 = 20 \text{ ft} \quad l_n = l'_n = 22.33 \text{ ft} \quad \left( 1 + \frac{1}{\alpha_{ec}} \right) = 1.87$$

The unbalanced moment to be transferred to the exterior column using Eq. 17.22b is

$$M_u = \frac{0.08}{1.87} [(0.16 + 0.08)(20)(22.33)^2 - 0] = 102 \text{ K} \cdot \text{ft}$$

If Eq. 17.22a is used,  $M_u = 168 \text{ K} \cdot \text{ft}$ , which is a conservative value.

2. At an interior support, the slab stiffness on both sides of the column must be used to compute  $\alpha_{ec}$ :

$$\alpha_{ec} = \frac{K_{cc}}{\sum(K_s + K_b)} \quad (\text{Eq. 17.21})$$

From Example 17.5,  $K_{cc} = 233 E_c$ ,  $K_s = 202.5 E_c$ , and  $K_b = 0$ . Therefore,

$$\alpha_{ec} = \frac{233E_c}{(2)202.5E_c} = 0.58$$

$$\left( 1 + \frac{1}{\alpha_{ec}} \right) = 1 + \frac{1}{0.58} = 2.72$$

From Eq. 17.22b, the unbalanced moment at an interior support is

$$M_u = \frac{0.08}{2.72} [(0.16 + 0.08)(20)(22.33)^2 - 0.16(20)(22.33)^2] = 23 \text{ K} \cdot \text{ft}$$

If Eq. 17.22a is used,  $M_u = 42 \text{ K} \cdot \text{ft}$ , which is a conservative value.

**Example 17.9**

For the flat plate in Example 17.4, calculate the shear stresses in the slab at the critical sections due to unbalanced moments and shearing forces at an interior and exterior column. Check the concentration of reinforcement and torsional requirements at the exterior column. Use  $f'_c = 4$  ksi and  $f_y = 60$  ksi.

**Solution**

- The unbalanced moment at the interior support is  $M_u = 23 \text{ K} \cdot \text{ft}$  (Example 17.8), where  $\gamma_f = 0.6$  (because  $c_1 = c_2 = 20$  in.). The moment to be transferred by flexure is

$$M_f = \gamma_f M_u = 0.6 \times 23 = 13.8 \text{ K} \cdot \text{ft}$$

The moment to be transferred by shear is

$$M_v = 23 - 13.8 = 9.2 \text{ K} \cdot \text{ft}$$

Alternatively, moments calculated from Eq. 17.22a may be used producing higher shear stresses.

Using  $d = 7.9$  in. (Example 17.4),

$$V_u = 0.33 \left[ 20 \times 24 - \left( \frac{27.9}{12} \right)^2 \right] = 156.6 \text{ K}$$

From Fig. 17.27,

$$A_c = 4(27.9)(7.9) = 882 \text{ in.}$$

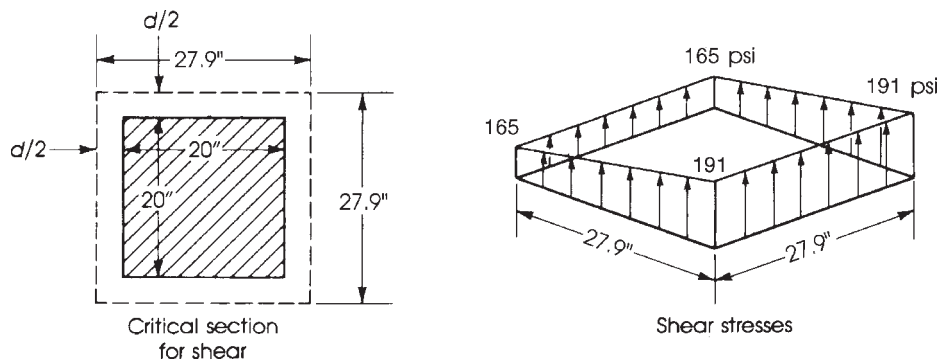
$$J_c = \frac{d}{2} \left( \frac{x^3}{3} + x^2 y \right) + \frac{xd^3}{6}$$

$$= \frac{7.9}{2} \left[ \frac{(27.9)^3}{3} + (27.9)^2(27.9) \right] + \frac{27.9}{6}(7.9)^3 = 114,670 \text{ in.}^4$$

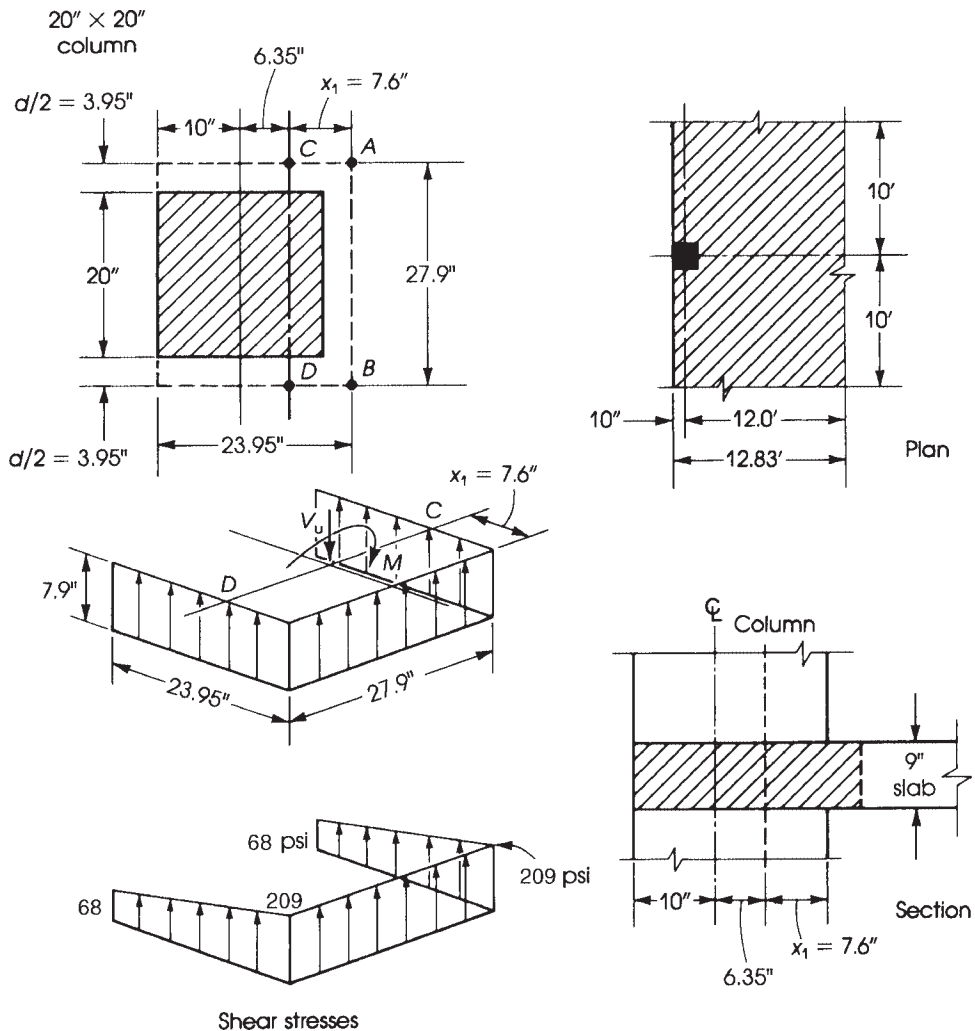
$$v_{\max} = \frac{156,600}{882} + \frac{9.2(12,000)(27.9/2)}{114,670}$$

$$= 177 + 13 = 190 \text{ psi}$$

$$v_{\min} = 177 - 13 = 164 \text{ psi}$$



**Figure 17.27** Example 17.9: Shear stresses at interior column due to unbalanced moment.



**Figure 17.28** Example 17.9: Shear stresses at exterior column due to unbalanced moment.

$$\text{Allowable } v_c \text{ is } \phi 4 \sqrt{f'_c} = 0.75 \times 4 \sqrt{4000} = 190 \text{ psi}$$

$$\text{Since } v_{\max} = 190 \text{ psi} \leq v_c = 190 \text{ psi (safe design)}$$

- For the exterior column, the unbalanced moment to be transferred by flexure  $M_f$  at a slab-column joint is equal to  $\gamma_f M_u$ , where  $M_u = 102 \text{ K} \cdot \text{ft}$ . Note that  $c_1 = c_2 = 20 \text{ in.}$ ,  $d = 7.9 \text{ in.}$  in the longitudinal direction, and  $\gamma_f = 0.6$  for square columns.

$$M_f = 0.6(102) = 61.2 \text{ K} \cdot \text{ft}$$

The moment to be transferred by shear is

$$M_v = M_u - M_f = 102 - 61.2 = 40.8 \text{ K} \cdot \text{ft}$$

3. For transfer by shear at exterior column, the critical section is located at a distance  $d/2$  from the face of the column (Fig. 17.28).

$$q_u = 330 \text{ psf}$$

$$V_u = 0.33 \left( 20 \times 12.83 - \frac{23.95}{12} \times \frac{27.9}{12} \right) = 83.1 \text{ K}$$

Locate the centroid of the critical section by taking moments about  $AB$ :

$$2 \left( 23.95 \times \frac{23.95}{2} \right) = (2 \times 23.95 + 27.9)x_l$$

Therefore,  $x_l = 7.6$  in. The area of the critical section  $A_c$  is  $2(23.95 \times 7.9) + (27.9 \times 7.9) = 599 \text{ in.}^2$  Calculate  $J_c = I_x + I_y$  for the two equal areas  $(7.9 \times 23.95)$  with sides parallel to the direction of moment and the area  $(7.9 \times 27.9)$  perpendicular to the direction of moment, all about the axis through  $CD$ .

$$\begin{aligned} J_c &= I_y + I_x = \sum \left( \frac{bh^3}{12} + Ax^2 \right) \\ &= 2 \left[ 7.9 \frac{(23.95)^3}{12} + (7.9 \times 23.95) \left( \frac{23.95}{2} - 7.6 \right)^2 \right] \\ &\quad + (1) \left[ \frac{27.9}{12} (7.9)^3 \right] + [(27.9 \times 7.9)(7.6)^2] = 39,208 \text{ in.}^4 \end{aligned}$$

or by using Eq. 17.31 for an exterior column. Calculate the maximum and minimum nominal shear stresses using Eq. 17.27:

$$v_{\max} = \frac{V_u}{A_c} + \frac{M_u c}{J_c} = \frac{83,100}{599} + \frac{40.2(12,000)(7.6)}{39,208} = 232 \text{ psi}$$

$$v_{\min} = 138 \text{ psi}$$

$$\text{Allowable } v_c = \phi 4 \sqrt{f'_c} = 0.75 \times 4 \sqrt{4000} = 190 \text{ psi}$$

Shear stress is greater than the allowable  $v_c$ , so increase the slab thickness  $f'_c$  or use shear reinforcement.

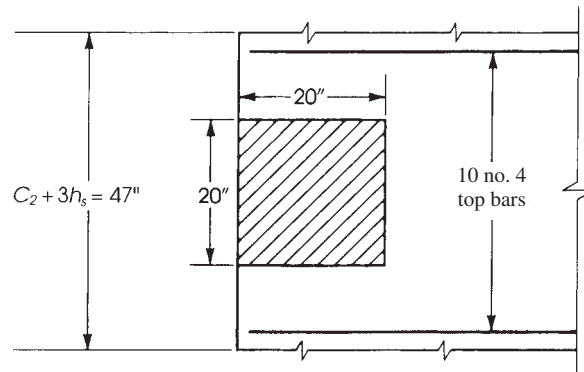
4. Check the concentration of reinforcement at the exterior column; that is, check that the flexural capacity of the section is adequate to transfer the negative moment into the exterior column. The critical area of the slab extends  $1.5h$  on either side of the column, giving an area  $(20 + 3 \times 9) = 47$  in. wide and 9 in. deep. The total moment in the 120-in.-wide column strip is 107 K · ft, as calculated in Example 17.4 (step 5). The moment in a width,  $c_2 + 3h = 47$  in., is equal to  $107 \left( \frac{47}{120} \right) = 41.9 \text{ K} \cdot \text{ft}$ .

If equal spacing in the column strip is used, then the additional reinforcement within the 47-in. width will be needed for a moment equal to  $M_f - 41.9 = 66 - 41.9 = 24.1 \text{ K} \cdot \text{ft}$ . The required  $A_s = 0.73 \text{ in.}^2$  and four no. 4 bars ( $A_s = 0.8 \text{ in.}^2$ ) may be used. An alternative solution is to arrange the reinforcement within the column strip to increase the reinforcement within a width of 47 in. The amount of steel needed within this width should be enough to resist a moment of 0.6 times the negative moment in the column strip, or  $0.6 \times 107 = 64.2 \text{ K} \cdot \text{ft}$ .

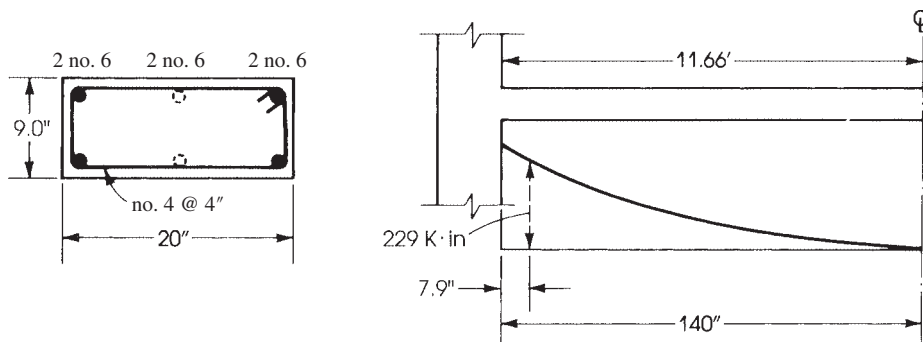
$$A_s = \frac{M_u}{\phi f_y (d - a/2)}$$

Assume  $a = 1.0$  in. Then

$$A_s = \frac{64.2(12)}{0.9 \times 60(7.9 - 0.5)} = 1.93 \text{ in.}^2$$



**Figure 17.29** Example 17.9: Concentration of reinforcement within exterior column strip.



**Figure 17.30** Example 17.9: Reinforcement in edge of slab to resist torque.

$$\text{Check: } a = \frac{A_s f_y}{0.85 f'_c b} = \frac{1.93 \times 60}{0.85 \times 4 \times 47} = 0.73 \text{ in.}$$

Use 10 no. 4 bars within a width 47 in. divided equally at both sides from the center of the column (Fig. 17.29). Additional reinforcement of four no. 4 bars, as indicated before, provides a better solution.

5. Torque on slab: The torque from both sides of the exterior column is equal to 40% of the column strip moment.

$$T_u = 0.4(107) = 42.8 \text{ K} \cdot \text{ft}$$

$$\text{Torque on each side: } \frac{42.8}{2} = 21.4 \text{ K} \cdot \text{ft} = 257 \text{ K} \cdot \text{in.}$$

A slab section of width equal to the column width will be assumed to resist the torsional stresses:

$$T_u = \frac{1}{3} v_{tu} \sum x^3 y$$

where  $x$  is 9 in. and  $y$  is 20 in. The critical section is at a distance  $d$  from the face of the column (Fig. 17.30). Assuming that the torque varies in a parabolic curve to the center of the slab, then the torque at a distance  $d$  is

$$T_u = 257 \left( \frac{140 - 7.9}{140} \right)^2 = 229 \text{ K} \cdot \text{in.}$$

For torsional strength of concrete,  $A_{cp} = 9 \times 20 = 180$  in.,  $P_{cp} = 2(9 + 20) = 58$  in. By Eq. 15.19,  $\phi T_{cp} = 0.75(4)\sqrt{4000}(180)^2/58 = 106$  K·in. and  $T_u = 106/4 = 26.5$  K·in.  $< T_u$ .

Torsional reinforcement is needed. The required closed stirrups and the additional longitudinal bars are determined as explained in Chapter 15. The final section is shown in Fig. 17.30. It is advisable to provide an edge beam between the exterior columns to increase the torsional stiffness of the slab.

### Example 17.10

Determine the shear reinforcement required for an interior flat plate panel considering the following: Punching shear is  $V_u = 195$  K, slab thickness = 9 in.,  $d = 7.5$  in.,  $f'_c = 4$  ksi,  $f_y = 60$  ksi,  $\lambda = 1.0$ , and column size is  $20 \times 20$  in., and panel has equal dimensions.

### Solution

1. Determine  $\phi V_c$  for two-way shear:

$$b_0 = 4(20 + d) = 4(20 + 7.5) = 110 \text{ in.}$$

$$\begin{aligned}\phi V_c &= \phi \left( 2 + \frac{4}{\beta} \right) \sqrt{f'_c} b_0 d \\ &= 0.75 \left( 2 + \frac{4}{1} \right) \frac{\sqrt{4000}}{1000} (110)(7.5) = 234.8 \text{ K}\end{aligned}$$

$$\phi V_c = \phi \left( \frac{\alpha_s d}{b_0} + 2 \right) \sqrt{f'_c} b_0 d$$

$$\alpha_s = 40 \quad (\text{Interior plate})$$

$$\begin{aligned}\phi V_c &= 0.75 \left( \frac{40 \times 7.5}{110} + 2 \right) \sqrt{4000} \times 110 \times 7.5 \\ &= 185 \text{ K}\end{aligned}$$

$$\phi V_c = \phi 4\lambda \sqrt{f'_c} b_0 d$$

$$\phi V_c = 0.75(4)(1.0) \frac{\sqrt{4000}}{1000} (110)(7.5) = 156.3 \text{ K (controls)}$$

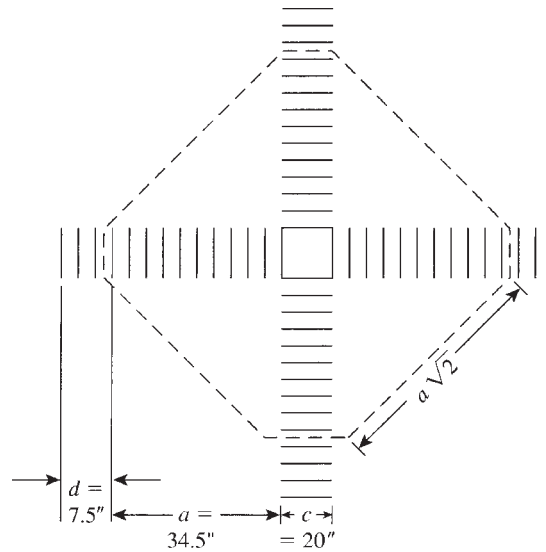
Because  $V_u = 195 \text{ K} > \phi V_c = 156.3 \text{ K}$ , shear reinforcement is required.

2. Maximum allowable  $\phi V_n$  using shear reinforcement is equal to  $\phi 6\lambda \sqrt{f'_c} b_0 d = 1.5(\phi V_c) = 234.5 \text{ K}$ . Because  $\phi V_n > V_u$ , shear reinforcement can be used.
3. Shear reinforcement may consist of reinforcing bars, structural steel sections such as I-beams, or special large-head studs welded to a steel strip. In this example, an inexpensive solution using normal shear reinforcement will be adopted. See Fig. 17.9f. Shear reinforcement must be provided on the four sides of the interior column (or three sides of an exterior column) for a distance of  $d + a$ . See Fig. 17.31. The distance 'a' is determined by equating  $\phi V_c = V_u$  at section  $b_0$ , indicated by the dashed line, and assuming  $\phi V_c = \phi 2\lambda \sqrt{f'_c} b_0 d$ .

$$b_0 = 4(c + \sqrt{2a}) = 4(20 + \sqrt{2a})$$

$$0.75(2)\sqrt{4000}(4)(20 + \sqrt{2a})(7.5) = 195,000 \text{ lb}$$

Here,  $a = 34.3$  in., and  $(a + d) = 34.3 + 7.5 = 41.8$  in., so use 42 in.



**Figure 17.31** Example 17.10: Shear reinforcement no. 3 at 3.5 in.

4. Calculate shear reinforcement:

$$\phi V_s = (V_u - \phi V_c) = 195 - 156.3 = 38.7K \quad \phi = 0.75 \quad V_s = 51.6K$$

$$V_s(\text{for one face of critical section}) = \frac{V_s}{4} = \frac{51.6}{4} = 12.9K$$

Use no. 3 U-stirrups,  $A_v = 0.22 \text{ in.}^2$  (for two legs). The spacing is  $S = A_v f_y d / V_s = 0.22(60)(7.5) / 12.9 = 7.7 \text{ in.}$  Maximum spacing is  $d/2 = 7.5/2 = 3.75 \text{ in.}$ ; let  $s = 3.5 \text{ in.}$

5. Distribution of stirrups: The number of stirrups per one side of column is  $43/3.5 = 12.3$ , or 13 stirrups. Total distance is  $13(3.5) = 45.5 \text{ in.}$  (Fig. 17.31).

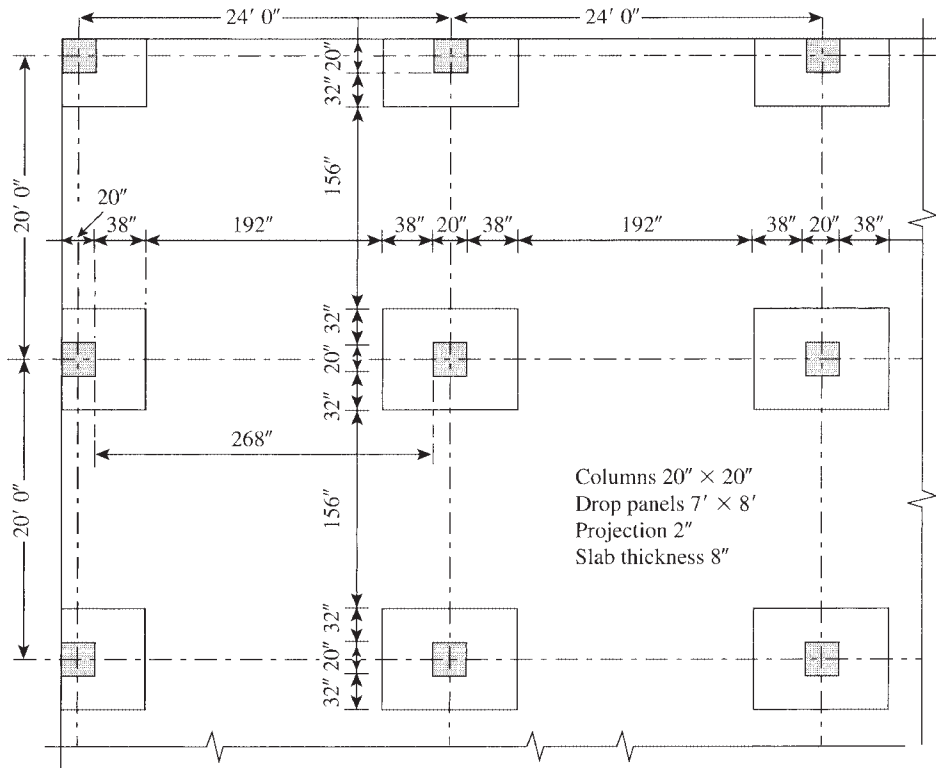
### Example 17.11 Flat-Slab Floor System

Using the direct design method, design a typical  $24 \times 20$ -ft interior flat-slab panel with drop panels only (Fig. 17.32). All panels are supported by  $20 \times 20$ -in. columns, 12 ft long. The slab carries a uniform service live load of 80 psf and a service dead load of 24 psf, excluding self-weight. Use  $f'_c = 4 \text{ ksi}$ , and  $f_y = 60 \text{ ksi}$ . (The solution is similar to Example 17.3.)

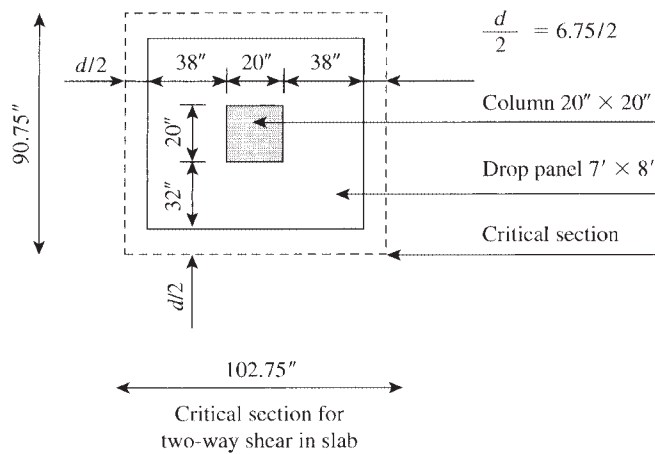
#### Solution

1. Determine slab and drop panel thicknesses using Table 17.1.
  - a. The clear span is  $24 - \frac{20}{12} = 22.33 \text{ ft}$ . For an exterior panel, minimum  $h = l_n/33 = 8.12 \text{ in.}$ , whereas for an interior panel, minimum  $h = l_n/36 = 7.44 \text{ in.}$  Use a slab thickness of 8 in. The projection below the slab is  $h/4 = \frac{8}{4} = 2.0 \text{ in.}$ ; thus, the drop panel thickness is 10 in.
  - b. Extend the drop panels  $L/6 = \frac{24}{6} = 4 \text{ ft}$  in each direction from the centerline of support in the long direction and  $\frac{20}{6} = 3.33 \text{ ft}$ , or 3.5 ft, in the short direction. Thus, the total size of one drop panel is  $8 \times 7 \text{ ft}$  (Fig. 17.32).



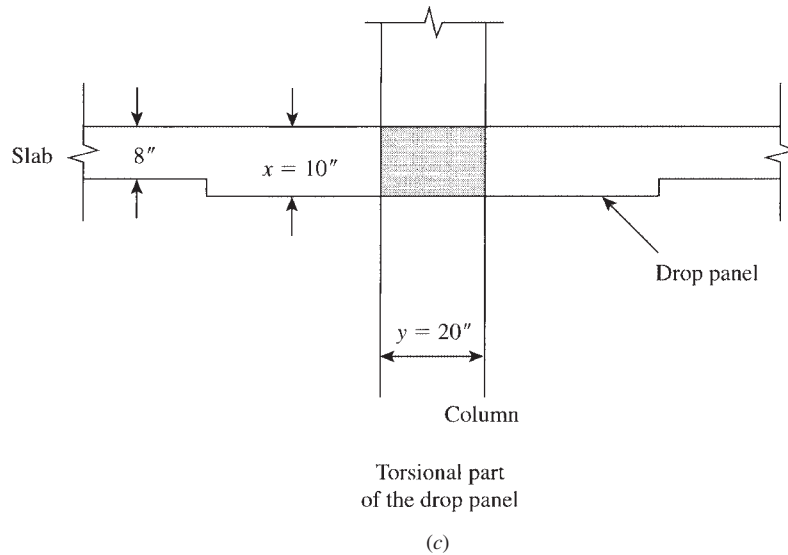


(a)



(b)

**Figure 17.32** Example 17.11: Flat slab with drop panel.



**Figure 17.32** (continued)

2. Calculate factored loads:

$$\text{Slabload} = 24 + \frac{8(150)}{12} = 124 \text{ psf}$$

$$q_u = 1.2(124) + 1.6(80) = 277 \text{ psf}$$

$$\text{Drop panel load} = 24 + \frac{10(150)}{12} = 149 \text{ psf}$$

$$q_u = 1.2(149) + 1.6(80) = 307 \text{ psf}$$

Because the drop panel length is  $L/3$  in each direction, the average  $q_u$  is  $\left(\frac{2}{3}\right)(277) + \left(\frac{1}{3}\right)(307) = 287 \text{ psf}$ .

3. Check two-way shear (at distance  $d/2$  from the face of column):

- a. In the drop panel:  $d = 10 - 0.75 - 0.5 = 8.75 \text{ in}$ .

$$V_u = 0.287 \left[ 24 \times 20 - \left( \frac{28.75}{12} \right)^2 \right] = 136.1 \text{ K}$$

$$b_0 = 4(20 + 8.75) = 115 \text{ in.}$$

$$\phi V_c = \phi \left( 2 + \frac{4}{\beta} \right) \sqrt{f'_c} b_0 d$$

$$\beta = \frac{24}{20} = 1.2$$

$$\begin{aligned} \phi V_c &= 0.75 \times \left( 2 + \frac{4}{1.2} \right) \frac{\sqrt{4000}}{1000} \times 115 \times 8.75 \\ &= 254.38 \text{ K} \end{aligned}$$

$$\phi V_c = \phi \left( \frac{\alpha_s d}{b_0} + 2 \right) \sqrt{f'_c} b_0 d$$

$$\alpha_s = 40 \quad (\text{Interior panel})$$

$$\begin{aligned} \phi V_c &= \phi \left( \frac{40 \times 8.75}{115} + 2 \right) \times \frac{\sqrt{4000}}{1000} \times 115 \times 8.75 \\ &= 240.75 \text{ K} \end{aligned}$$

$$\phi V_c = \phi \lambda 4 \sqrt{f'_c} b_0 d = (0.75)(4)(1) \frac{\sqrt{4000}}{1000} (115)(8.75) = 190.9 \text{ K (controls)} > V_u$$

- b.** In the slab:  $d = 8 - 0.75 - 0.5 = 6.75$  in. and  $b_0$  is measured at  $6.75/2$  in. (in slab) beyond the drop panel.

$$V_u = 0.287[24 \times 20 - (102.75)(90.75)/144] = 119.2 \text{ K}$$

$$b_0 = 2(8 \times 12 + 6.75) + 2(7 \times 12 + 6.75) = 387 \text{ in.}$$

$$\phi V_c = \phi \left( 2 + \frac{4}{\beta} \right) \sqrt{f'_c} b_0 d$$

$$\beta = 1.2$$

$$\begin{aligned} \phi V_c &= 0.75 \left( 2 + \frac{4}{1.2} \right) \times \frac{\sqrt{4000}}{1000} \times 387 \times 6.75 \\ &= 660.74 \text{ K} \end{aligned}$$

$$\phi V_c = \phi \left( \frac{\alpha_s d}{b_0} + 2 \right) \sqrt{f'_c} b_0 d$$

$$\alpha_s = 40$$

$$\begin{aligned} \phi V_c &= 0.75 \left( \frac{40 \times 6.75}{387} + 2 \right) \frac{\sqrt{4000}}{1000} \times 387 \times 6.75 \\ &= 334 \text{ K (controls)} \end{aligned}$$

$$\phi V_c = 0.75(4)(1) \frac{\sqrt{4000}}{1000} (387)(6.75) = 495.6 \text{ K}$$

Since  $334 \text{ K} > V_u$ , check OK.

- c.** One-way shear is not critical.

- 4.** Calculate the total static moments in the long and short directions:

$$M_{0l} = \frac{0.287(20)(22.33)^2}{8} = 357.8 \text{ K} \cdot \text{ft}$$

$$M_{0s} = \frac{0.287(24)(18.33)^2}{8} = 289.3 \text{ K} \cdot \text{ft}$$

The width of column strip in each direction is  $\frac{20}{2} = 10$  ft, whereas the width of the middle strip is 10 ft in the long direction and 14 ft in the short direction.

- 5.** Calculations of moments and steel reinforcement are shown in Table 17.11. Use an average  $d = 10 - 1.5 = 8.5$  in. in the column strip and  $d = 8 - 1.5 = 6.5$  in. in the middle strip.

Bars are chosen for adequate distribution in both the column and middle strip. Reinforcement details are similar to those in flat-plate examples.

**Table 17.11** Design of an Interior Flat-Slab Floor System

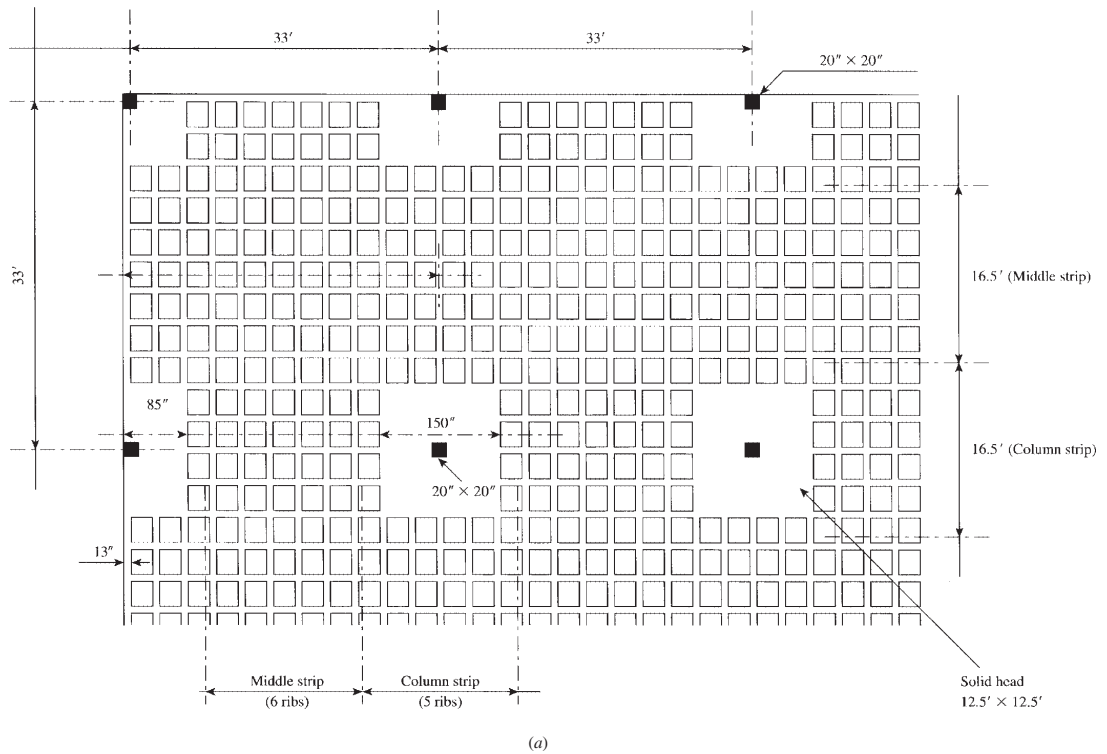
$M_{0l} = 358 \text{ K}\cdot\text{ft}$	Column Strip		Middle Strip	
<b>Long direction</b>				
$M$ factor	$-0.49M_0$	$0.21M_0$	$-0.16M_0$	$0.14M_0$
$M_u$ (K · ft)	-175.4	$\pm 75.2$	-57.3	$\pm 50.1$
Width of strip (in.), $b$	120	120	120	120
Effective depth (in.), $d$	8.5	6.5	6.5	6.5
$R_u = \frac{M_u}{bd^2}$ (psi)	243	178	129	119
Steel ratio $\rho$ (%)	0.48	0.34	0.25	0.23
$A_s = \rho bd$ (in. <sup>2</sup> )	4.9	2.65	1.95	1.79
Min. $A_s = 0.0018bh_s$ (in. <sup>2</sup> )	2.16	2.16	1.73	1.73
Selected bars	16 no. 5	14 no. 4	10 no. 4	9 no. 4
<hr/>				
$M_{0s} = 289.3 \text{ K}\cdot\text{ft}$	Column Strip		Middle Strip	
<b>Short Direction</b>				
$M$ factor	$-0.49M_0$	$0.21M_0$	$-0.16M_0$	$0.14M_0$
$M_u$ (K · ft)	-142	$\pm 60.8$	-46.3	$\pm 40.5$
Width of strip (in.), $b$	120	120	168	168
Effective depth (in.), $d$	8.5	6.5	6.5	6.5
$R_u = \frac{M_u}{bd^2}$ (psi)	196	144	78	68
Steel ratio $\rho$ (%)	0.38	0.28	0.15	0.13
$A_s = \rho bd$ (in. <sup>2</sup> )	3.9	2.2	1.64	1.42
Min. $A_s = 0.0018bh_s$ (in. <sup>2</sup> )	2.16	2.16	2.42	2.42
Selected bars	13 no. 5	11 no. 4	12 no. 4	12 no. 4

## 17.11 WAFFLE SLABS

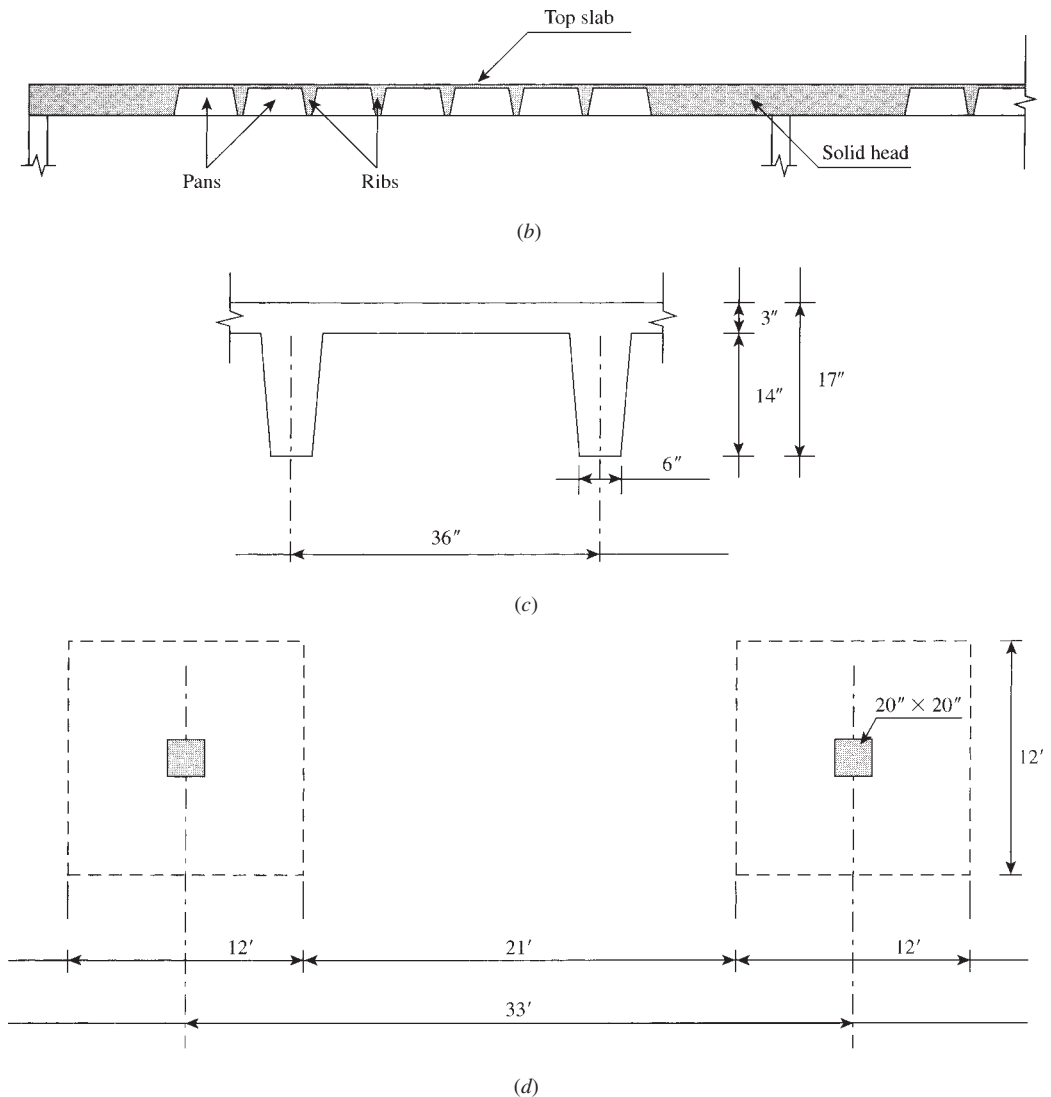
A two-way waffle slab system consists of concrete ribs that normally intersect at right angles. These slabs might be constructed without beams, in which case a solid column head is made over the column to prevent any punching due to shear. Wide beams can also be used on the column centerlines for uniform depth construction. Square metal or fiberglass pans are commonly used to form these joists. A thin slab of 3 to 5 in. is cast with these joists to form the waffle slab.

Each panel is divided into a column and a middle strip. The column strip includes all joists that frame into the solid head; the middle strip is located between consecutive column strips. Straight or bent bars could be used as reinforcement in a waffle slab. The design of a two-way waffle slab is similar to that of flat slabs by considering the solid head as a drop panel. To prevent any excess in the diagonal tension in the head, a sufficient size of column must be used or a shear cap must be provided.

In the design of a waffle slab, the top slabs with each rib form a T-section, with considerable depth relative to flat plates. Consequently, long spans carrying heavy loads may be designed with great savings in concrete. Waffle slabs also provide an attractive ceiling, which is achieved by



**Figure 17.33** (a) Plan of the waffle slab, (b) cross section, (c) pan and rib dimensions, and (d) spacing and dimensions of solid heads (Example 17.12).



**Figure 17.33** (continued)

leaving the rib pattern or by integrating lighting fixtures. The standard pans that are commonly used in waffle slabs can be one of the following two types:

1. 30 × 30-in. square pans with a 3-in. top slab, from which 6-in.-wide ribs at 36 in. (3 ft) on centers are formed. These are available in standard depths of 8 to 20 in. in 2-in. increments. Refer to Example 17.12 and Fig. 17.33.
2. 19 × 19-in. square pans with a 3-in. top slab, from which 5-in.-wide ribs at 24 in. (2 ft) on centers are formed. These are available in standard depths of 4, 6, 8, 10, and 12 in. Other information about pans is shown in Table 17.12 [17]. Other types, ranging from 19 × 19-in. pans to 40 × 40-in. pans, are available in the construction industry.

**Table 17.12** Gross Section Properties [17]

Top Slab (in.)	Rib Depth (in.)	Volume (cf/pan)	Gross Area (in. <sup>2</sup> )	$Y_{cg}$ (in.)	$I_g$ (in. <sup>4</sup> )
<b>For the Joists (19 × 19-in. pans)</b>					
3	8	3.85	161.3	3.28	1393
3	10	4.78	176.3	3.95	2307
3	12	5.53	192	4.66	3541
3	14	6.54	208.3	5.42	5135
3	16	7.44	223.3	6.20	7127
3	20	9.16	261.3	7.83	12,469
4.5	8	3.85	215.3	3.77	2058
4.5	10	4.78	230.3	4.35	3227
4.5	12	5.53	246.0	4.97	4783
4.5	14	6.54	262.3	5.66	6773
4.5	16	7.44	279.3	6.36	9238
4.5	20	9.16	315.3	7.86	15,768
<b>For the Joists (30 × 30-in. pans)</b>					
3	6	1.09	105	2.886	598
3	8	1.41	117.4	3.564	1098
3	10	1.9	130.4	4.303	1824
3	12	2.14	144	5.083	2807
4.5	6	1.09	141	3.457	957
4.5	8	1.41	153	4.051	1618
4.5	10	1.9	166.4	4.709	2550
4.5	12	2.14	180	5.417	3794

**Example 17.12 Waffle Slab**

Design a waffle floor system that consists of square panels without beams considering the following data (Fig. 17.33):

Span, center to center of columns = 33 ft

Width of rib = 6 in., spaced at 36 in. on centers

Depth of rib = 14 in. and slab thickness = 3 in.

Column size = 20 × 20 in.

Dead load(excluding self – weight) = 50 psf

Live load = 100 psf

$$f'_c = 5 \text{ ksi} \quad f_y = 60 \text{ ksi} \quad \lambda = 1.0$$

**Solution**

- Determine minimum slab thickness using Table 17.1: Minimum  $h = l_n/30$ ,  $l_n = 33 - \frac{20}{12} = 31.33$  ft,  $h = 31.33(12)/30 = 12.5$  in. for exterior panels, and  $h = l_n/33 = 11.4$  in. for interior panels. Equations 17.1 and 17.2 may be used. Assume the total depth is 17 in. consisting of 3-in. slab thickness and 14-in. rib depth.
- Calculate loads on the waffle slab:
  - Factored load of solid head part =  $1.2(150)(17/12) = 255$  psf.

- b. Voided volume of 14-in. rib =  $6.54 \text{ ft}^3$  on  $3 \times 3 \text{ -ft}^2$  area. Total weight of  $9\text{-ft}^2$  area is  $1.2(150) \left( 9 \times \frac{17}{12} - 6.54 \right) = 1118 \text{ lb}$ . Weight per square foot is  $\frac{1118}{9} = 125 \text{ psf}$ .
- c. Factored additional dead plus live load is  $1.2(50) + 1.6(100) = 220 \text{ psf}$ . Uniform  $q_u$  at solid (head) =  $255 + 220 \approx 500 \text{ psf}$ . Uniform  $q_u$  (at ribbed area) =  $125 + 220 = 345 \text{ psf}$ .
- d. Loads on one panel (refer to Fig. 17.34): At the solid head,  $q_u = 0.5(12) + 0.345(21) = 13.22 \text{ K/ft}$ . At the ribbed area,  $q_u = 0.345(33) = 11.39 \text{ K/ft}$ .
3. Calculate shear and total static moment:

$$V_u(\text{at face of column}) = 13.22(5.17) + \frac{(11.39)(21)}{2} = 188 \text{ K}$$

$$M_0(\text{at midspan}) = 188(15.67) - 13.22(5.17)(13.09) - \frac{11.39(10.5)^2}{2} = 1424 \text{ K} \cdot \text{ft}$$

4. Check punching shear (refer to Fig. 17.35):

- a. In the solid head at  $d/2$  from the column face,  $h = 17 \text{ in.}$ ,  $d = 17 - 1.25 = 15.75 \text{ in.}$ ,  $c$  (column) =  $20 \text{ in.}$ ,  $b_0 = 4(20 + 15.75) = 143 \text{ in.}$ ,  $V_u = 11.39(21 \text{ ft}) + 13.22(12 \text{ ft}) - 0.5(37.75/12)^2 = 393.4 \text{ K}$  and

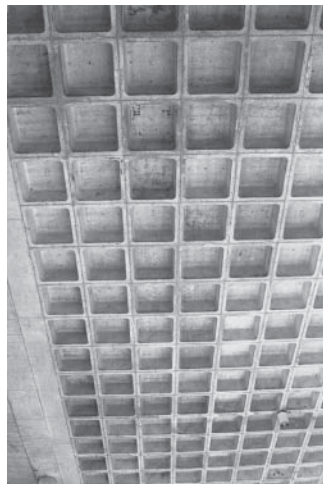
$$\phi V_c = \phi \left( 2 + \frac{4}{\beta} \right) \sqrt{f'_c} b_0 d$$

$$\beta = 1.0$$

$$\begin{aligned} \phi V_c &= 0.75 \left( 2 + \frac{4}{1.0} \right) \frac{\sqrt{5000}}{1000} \times 143 \times 15.75 \\ &= 716 \text{ K} \end{aligned}$$

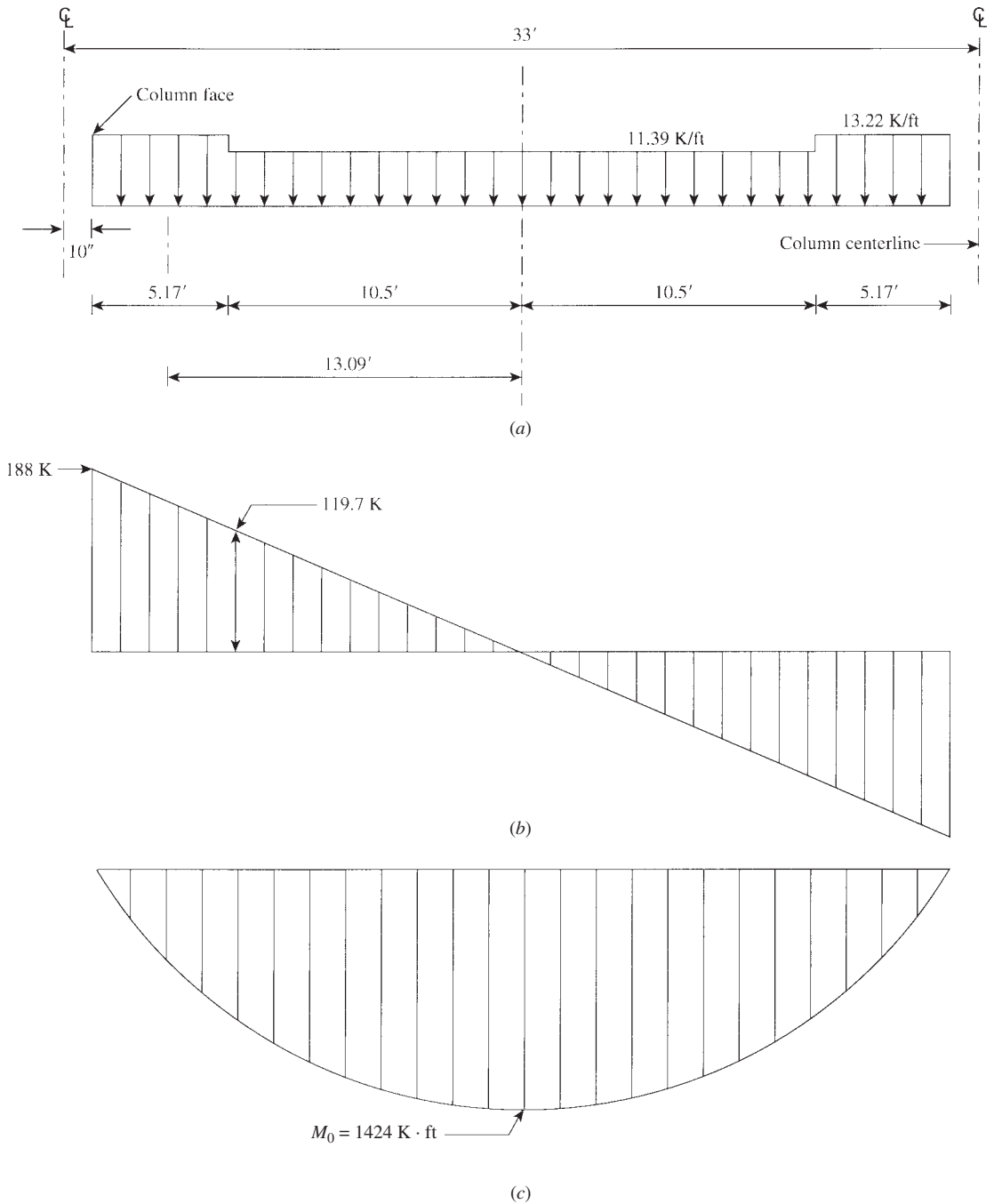
$$\begin{aligned} \phi V_c &= \phi \left( \frac{\alpha_s d}{b_0} + 2 \right) \sqrt{f'_c} b_0 d \\ &= 0.75 \left( \frac{40 \times 15.75}{143} + 2 \right) \frac{\sqrt{5000}}{1000} \times 143 \times 15.75 \\ &= 765 \text{ K} \end{aligned}$$

$$\phi V_c = \phi 4 \lambda \sqrt{f'_c} b_0 d = 0.75(4)(1.0) \left( \frac{\sqrt{5000}}{1000} \right) (143)(15.75) = 478 \text{ K (controls)} > V_u$$

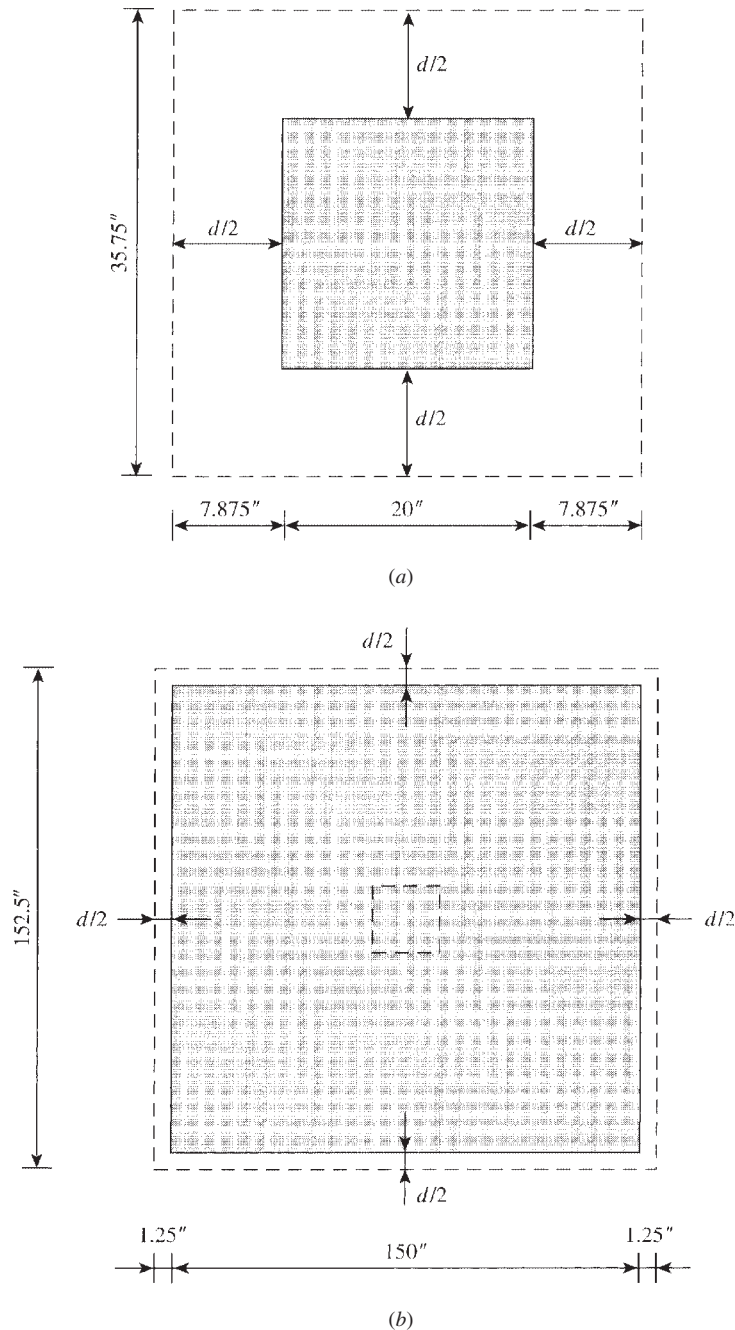


Waffle slab (looking upward).





**Figure 17.34** Load, shear, and moment diagrams: (a) load distribution on the span, (b) shear force diagram, and (c) bending moment diagram.



**Figure 17.35** Punching shear locations: (a) punching shear in column head and (b) punching shear in slab.

**Table 17.13** Design of Exterior and Interior Waffle Slabs (5 Ribs in Column Strip and 6 Ribs in Middle Strips)

Exterior Panel	Column Strip			Middle Strip	
	Exterior			Interior	
	$-M$	$\pm M$	$-M$	$-M$	$\pm M$
Moment factor (%)	100	60	75	25	40
$M_u$ (K · ft)	370	444	748	249	296
Strip width, $b$ (in.)	150	198	150	36 (6 ribs)	198
$d$ (in.)	15.75	15.75	15.75	15.75	15.75
$R_u = \frac{M_u}{bd^2}$ (psi)	120	108	241	334	72
Steel ratio, $\rho$ (%)	0.226	0.204	0.465	0.657	0.135
$A_s = \rho bd$ (in. <sup>2</sup> )	5.33	6.36	11.0	3.73	4.2
Min. $A_s = 0.0018bh$	2.6	1.22	4.6	1.1	1.47
Bars selected	14 no. 6	2 no. 8/rib	26 no. 6	10 no. 6	2 no. 7/rib

Exterior Panel	Column Strip			Middle Strip	
	Exterior			Interior	
	$-M$	$\pm M$	$-M$	$-M$	$\pm M$
Moment factor (%)	—	60	75	25	40
$M_u$ (K · ft)	—	299	694.2	231.4	200
Strip width, $b$ (in.)	—	198	150	36 (6 ribs)	198
$d$ (in.)	—	15.75	15.75	15.75	15.75
$R_u = \frac{M_u}{bd^2}$ (psi)	—	73	224	311	49
Steel ratio, $\rho$ (%)	—	0.137	0.431	0.61	0.091
$A_s = \rho bd$ (in. <sup>2</sup> )	—	4.27	10.18	3.45	2.84
Min. $A_s = 0.10018bh$	—	1.22/rib	4.6	1.1	1.47
Bars selected	—	2 no. 7/rib	24 no. 6	10 no. 6	2 no. 6/rib

- b. In the slab at distance  $d/2$  from the edge of the solid head, slab thickness is 3 in.; let  $d = 2.15$  in. Then

$$b_0 = 4(150 + 2.5) = 610 \text{ in.}$$

$$V_u = 11.39(21) + 13.22(12) - 0.5 \left( \frac{152.5}{12} \right)^2 = 317.4 \text{ K}$$

$$\phi V_c = 0.75(4)(1.0)(\sqrt{5000})(610)(2.5) = 324 \text{ K} > V_u$$

5. Design moments and reinforcement:

- a. Exterior panel:  $M_0 = 1424 \text{ K} \cdot \text{ft}$

$$\text{Exterior negative moment} = 0.26M_0 = -370 \text{ K} \cdot \text{ft}$$

$$\text{Positive moment} = 0.52M_0 = +740 \text{ K} \cdot \text{ft}$$

$$\text{Interior negative moment} = 0.7M_0 = -997 \text{ K} \cdot \text{ft}$$

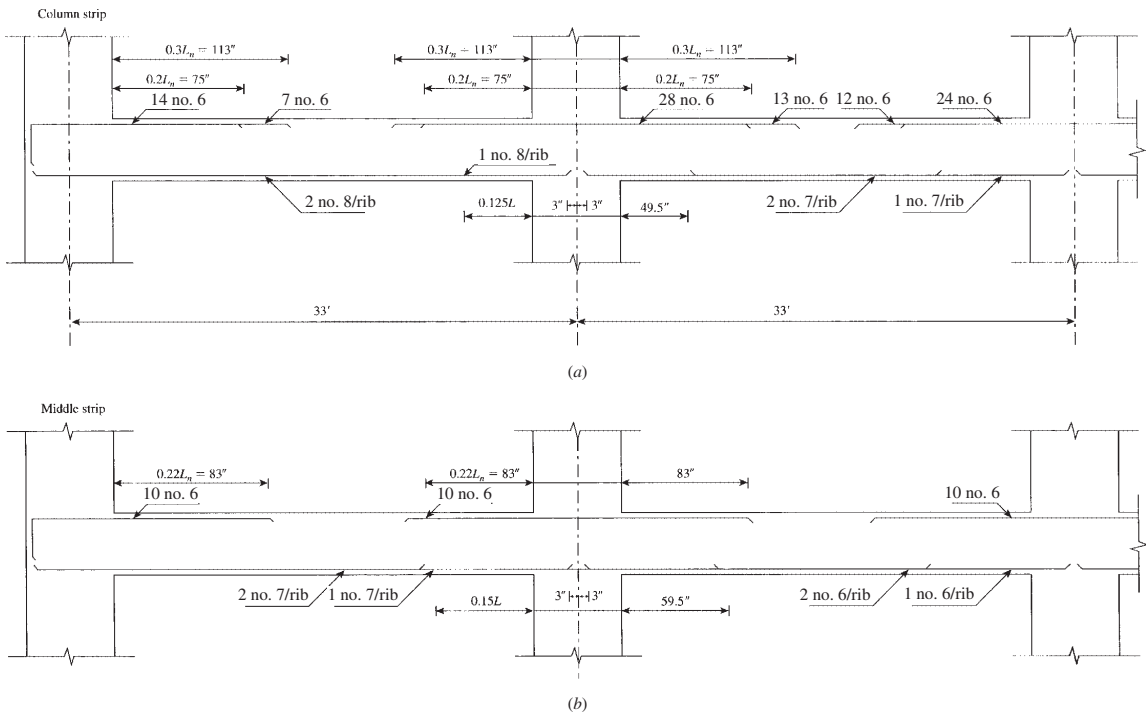


Figure 17.36 Example 17.12: Reinforcement details of the waffle slab.

b. Interior panel:  $M_0 = 1424 \text{ K} \cdot \text{ft}$

$$\text{Negative moment} = 0.65(1424) = -925.6 \text{ K} \cdot \text{ft}$$

$$\text{Positive moment} = 0.35(1424) = 498.4 \text{ K} \cdot \text{ft}$$

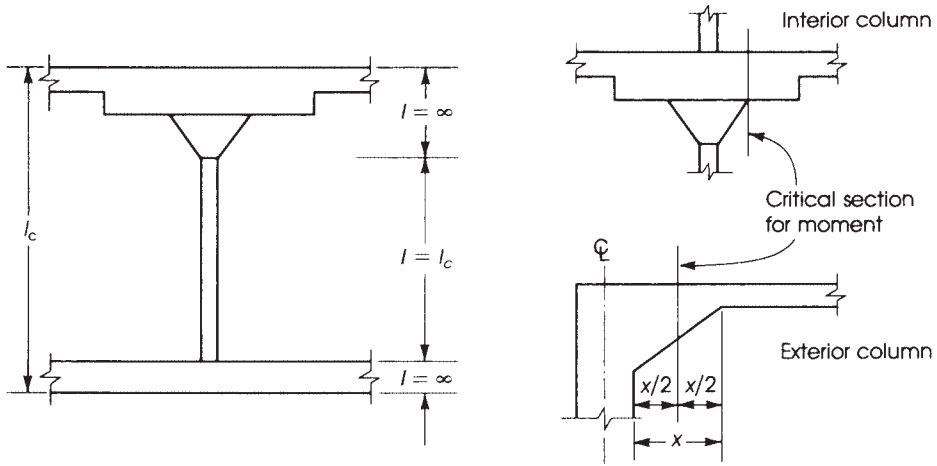
Design details are shown in Table 17.13 and Fig. 17.36. Note that all steel ratios are low and  $\phi = 0.9$ .

6. Calculate the unbalanced moments in columns and check shear for  $V_u$  and  $M_v$ , as in Examples 17.8 and 17.9.
- 

## 17.12 EQUIVALENT FRAME METHOD

When two-way floor systems do not satisfy the limitations of the direct design method, the design moments must be computed by the equivalent frame method. In the latter method, the building is divided into equivalent frames in two directions and then analyzed elastically for all conditions of loadings. The difference between the direct design and equivalent frame methods lies in the way by which the longitudinal moments along the spans of the equivalent rigid frame are determined. The design requirements can be explained as follows:

1. *Description of the equivalent frame:* An equivalent frame is a two-dimensional building frame obtained by cutting the three-dimensional building along lines midway between columns (Fig. 17.4). The resulting equivalent frames are considered separately in the longitudinal and transverse directions of the building. For vertical loads, each floor is analyzed separately, with the far ends of the upper and lower columns assumed to be fixed. The slab-beam may be assumed to be fixed at any support two panels away from the support considered because the vertical loads contribute very little to the moment at that support. For lateral loads, the equivalent frame consists of all the floors and extends for the full height of the building because the forces at each floor are a function of the lateral forces on all floors above the considered level. Analysis of frames can also be made using computer programs.
2. *Load assumptions:* When the ratio of the service live load to the service dead load is less than or equal to 0.75, the structural analysis of the frame can be made with the factored dead and live loads acting on all spans instead of a pattern loading. When the ratio of the service live load to the service dead load is greater than 0.75, pattern loading must be used, considering the following conditions:
  - a. Only 75% of the full-factored live load may be used for the pattern loading analysis.
  - b. The maximum negative bending moment in the slab at the support is obtained by loading only the two adjacent spans.
  - c. The maximum positive moment near a midspan is obtained by loading only alternate spans.
  - d. The design moments must not be less than those occurring with a full-factored live load on all panels (ACI Code, Section 6.4.3).
  - e. The critical negative moments are considered to be acting at the face of a rectangular column or at the face of the equivalent square column having the same area for nonrectangular sections.
3. *Slab-beam moment of inertia:* The ACI Code specifies that the variation in moment of inertia along the longitudinal axes of the columns and slab beams must be taken into account in the analysis of frames. The critical region is located between the centerline of the column and the



**Figure 17.37** Critical sections for column moment, equivalent frame method.

face of the column, bracket, or capital. This region may be considered as a thickened section of the floor slab. To account for the large depth of the column and its reduced effective width in contact with the slab beam, the ACI Code, Section 8.11.3.1, specifies that the moment of inertia of the slab beam between the center of the column and the face of the support is to be assumed equal to that of the slab beam at the face of the column divided by the quantity  $(1 - c_2/l_2)^2$ , where  $c_2$  is the column width in the transverse direction and  $l_2$  is the width of the slab beam. The area of the gross section can be used to calculate the moment of inertia of the slab beam.

4. *Column moment of inertia:* The ACI Code, Section 8.11.4.1, states that the moment of inertia of the column is to be assumed infinite from the top of the slab to the bottom of the column capital or slab beams (Fig. 17.37).
5. Column stiffness,  $K_{ec}$ , is defined by

$$\frac{1}{K_{ec}} = \frac{1}{\sum K_c} + \frac{1}{K_t} \quad (\text{Eq. 17.17})$$

where  $\sum K_c$  is the sum of the stiffness of the upper and lower columns at their ends,

$$K_t = \sum \frac{9E_{cs}C}{l_2(1 - C_2/l_2)^3} \quad (\text{Eq. 17.19})$$

$$C = \sum \left(1 - 0.63\frac{x}{y}\right) \left(\frac{x^3y}{3}\right) \quad (\text{Eq. 17.20})$$

6. *Column moments:* In frame analysis, moments determined for the equivalent columns at the upper end of the column below the slab and at the lower end of the column above the slab must be used in the design of a column.
7. *Negative moments at the supports:* The ACI Code, Section 8.11.6, states that for an interior column, the factored negative moment is to be taken at the face of the column or capital but at a distance not greater than  $0.1175l_1$  from the center of the column. For an exterior column, the factored negative moment is to be taken at a section located at half the distance between

the face of the column and the edge of the support. Circular section columns must be treated as square columns with the same area.

8. *Sum of moments:* A two-way slab floor system that satisfied the limitations of the direct design method can also be analyzed by the equivalent frame method. To ensure that both methods will produce similar results, the ACI Code, Section 8.11.6.5, states that the computed moments determined by the equivalent frame method may be reduced in such proportion that the numerical sum of the positive and average negative moments used in the design must not exceed the total statical moment,  $M_0$ .

### Example 17.13

Using the equivalent frame method, analyze a typical interior frame of the flat-plate floor system given in Example 17.3 in the longitudinal direction only. The floor system consists of four panels in each direction with a panel size of  $25 \times 20$  ft. All panels are supported by a  $20 \times 20$ -in. columns, 12 ft long. The service live load is 60 psf and the service dead load is 124 psf (including the weight of the slab). Use  $f'_c = 3$  ksi and  $f_y = 60$  ksi. Edge beams are not used. Refer to Fig. 17.38.

### Solution

1. A slab thickness of 8.0 in. is used.
2. Factored load is  $q_u = 1.2 \times 124 + 1.6 \times 60 = 245$  psf. The ratio of service live load to service dead load is  $60/124 = 0.48 < 0.75$ ; therefore, the frame can be analyzed with the full factored load,  $q_u$ , acting on all spans instead of pattern loading.
3. Determine the slab stiffness,  $K_s$ :

$$K_s = k \frac{E_{cs} I_s}{l_s}$$

where  $k$  is the stiffness factor and

$$I_s = \frac{l_2 h^3}{12} = \frac{20 \times 12}{12} (8)^3 = 10,240 \text{ in.}^4$$

The stiffness factor can be determined by the column analogy method described in books on structural analysis. Considering the moment of inertia for the slab  $I_s$  to be 1.0 as a reference, the moment of inertia between the column centerline and the face of the column is

$$\frac{1.0}{(1 - c_2/l_2)^2} = \frac{1.0}{[1 - 20/(20 \times 12)]^2} = 1.19$$

The width of the analogous column varies with  $1/I$ , as shown in Fig. 17.38b:  $(1/1.19) = 0.84$ :

$$\text{Slab stiffness factor } k = l_1 \left( \frac{1}{A_a} + \frac{Mc}{I_a} \right)$$

where

$A_a$  = area of analogous column section

$I_a$  = moment of inertia of analogous column

$M$  = moment due to unit load at extreme fiber of analogous column located at center of slab

$$M = 1.0 \times \frac{l_1}{2}$$

$$A_a = 23.33 + 2 \times (0.83 \text{ ft})(0.84) = 23.33 + 1.40 = 24.72$$

$I_a = I$  (for slab portion of 23.33) +  $I$  (of end portion) about centerline

$$I_a = \frac{(23.33)^3}{12} + 2(0.83)(0.84) \left( 12.5 - \frac{0.83}{2} \right)^2 = 1263$$

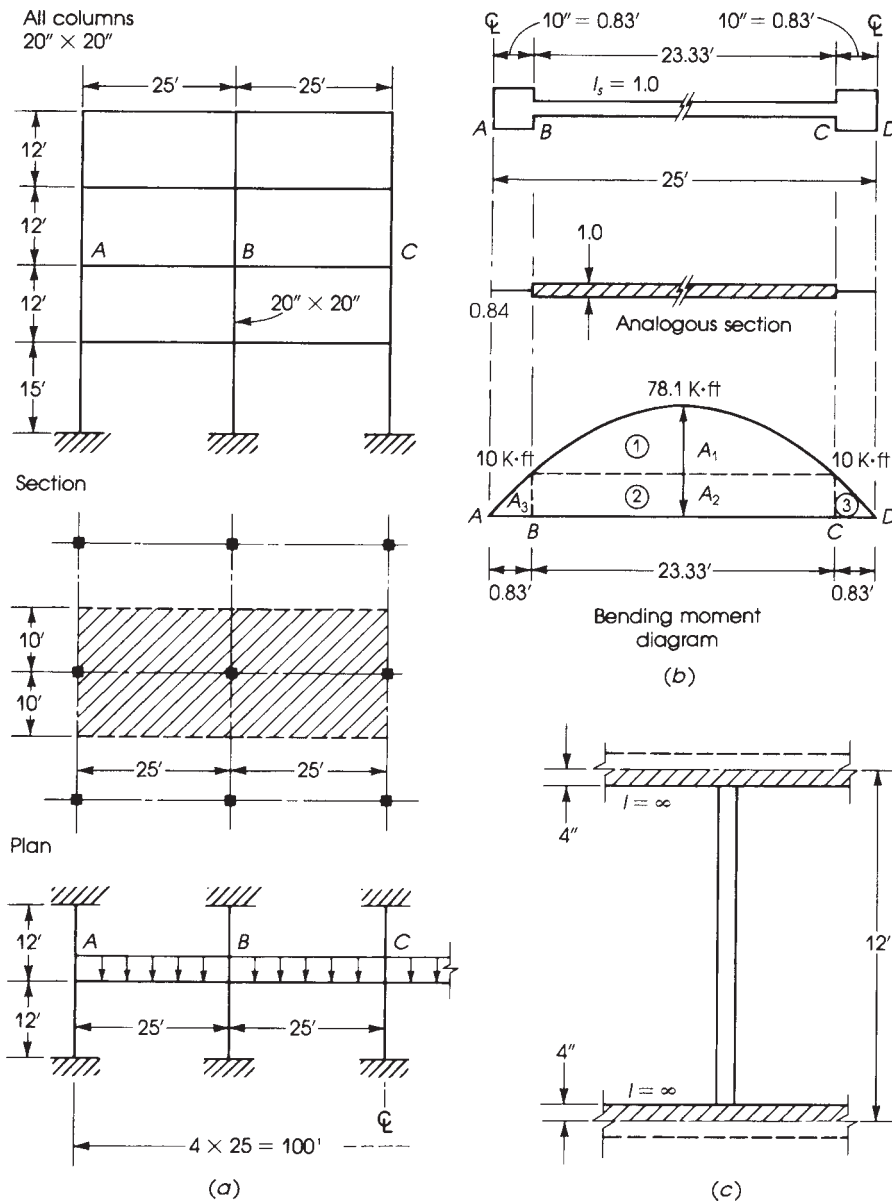


Figure 17.38 Example 17.13.

neglecting the moment of inertia of the short end segments about their own centroid.

$$\text{Stiffness factor } k = 25 \left[ \frac{1}{24.72} + \frac{1.0 \times 12.5 (12.5)}{1263} \right]$$

$$= 1.01 + 3.09 = 4.1$$

$$\text{Carryover factor} = \frac{3.09 - 1.01}{4.1} = 0.509$$



Therefore, slab stiffness is

$$K_s = \frac{4.1E_{cs} \times 10,240}{25 \times 12} = 140E_{cs}$$

4. Determine the column stiffness,  $K_c$ :

$$K_c = k' \left( \frac{E_{cb}I_c}{l_c} \right) \times 2$$

for columns above and below the slab.

$k'$  = column stiffness factor

$$l_c = 12 \text{ ft} \quad I_c = \frac{(20)^4}{12} = 13,333 \text{ in.}^4$$

The stiffness factor,  $k'$ , can be determined as follows:

$$k' = l_c \left( \frac{1}{A_a} + \frac{Mc}{I_a} \right)$$

For the column,  $c = l_c/2$  and  $M = 1.0(l_c/2) = l_c/2$ .

$$A_a = l_c - h = 12 - \frac{8}{12} = 11.33$$

$$I_a = \frac{(l_c - h)^3}{12} = \frac{(11.33)^3}{12} = 121.2$$

$$k' = 12 \left[ \frac{1}{11.33} + \frac{\left(1 \times \frac{12}{2}\right) \left(\frac{12}{2}\right)}{121.2} \right] = 4.62$$

$$K_c = 4.62E_{cb} \times \frac{13,333}{12 \times 12} \times 2 = 856E_{cb}$$

In a flat-plate floor system, the column stiffness,  $K_c$ , can be calculated directly as follows:

$$\frac{K_c}{E_{cb}} = \frac{I_c}{l_c - h} + \frac{3I_c l_c^2}{(l_c - h)^3} \quad (17.33)$$

5. Calculate the torsional stiffness,  $K_t$ , of the slab at the side of the column:

$$K_t = \frac{\sum 9E_{cs}C}{l_2(1 - c_2/l_2)^3} \quad \text{and} \quad C = \sum \left( 1 - 0.63 \frac{x}{y} \right) \frac{x^3 y}{3}$$

In this example,  $x = 8.0$  in. (slab thickness) and  $y = 20$  in. (column width). See Fig. 17.17.

$$c = \left( 1 - 0.63 \times \frac{8}{20} \right) \left( \frac{(8)^3 \times 20}{3} \right) = 2553 \text{ in.}^4$$

$$K_t = \frac{9E_{cs} \times 2553}{(20 \times 12)[1 - 20/(20 - 12)]^3} = 124E_{cs}$$

For two adjacent slabs,  $K_t = 2 \times 124E_{cs} = 248E_{cs}$ .

6. Calculate the equivalent column stiffness,  $K_{ec}$ :

$$\frac{1}{K_{ec}} = \frac{1}{\sum K_c} + \frac{1}{K_t} = \frac{1}{856E_{cb}} + \frac{1}{248E_{cs}}$$

or  $K_{ec} = 192E_{cs}$ . ( $E_{cb} = E_{cs}$  in this problem).

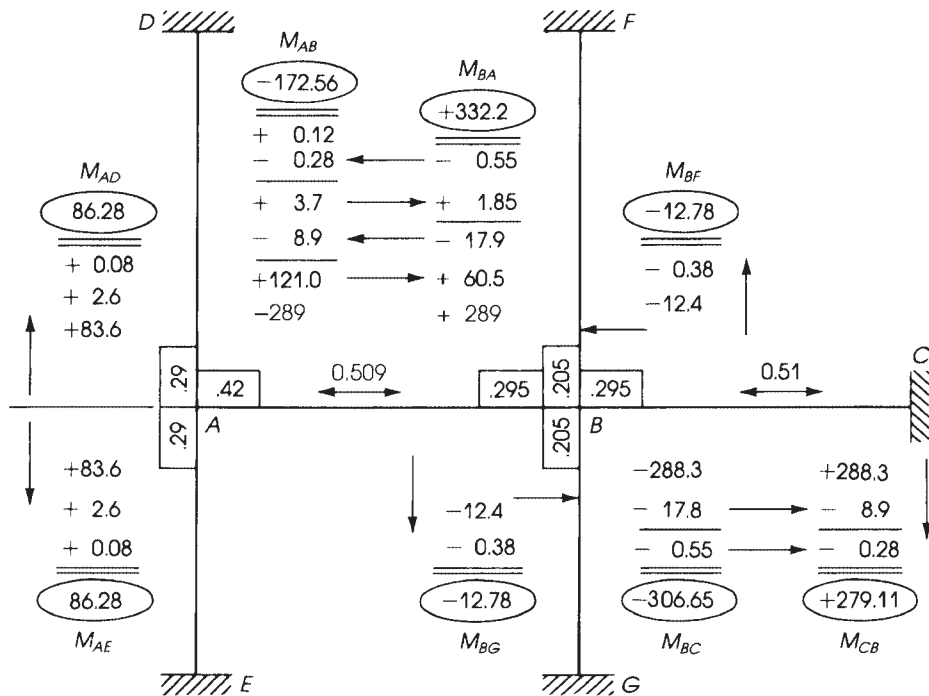


Figure 17.39 Example 17.13: Analysis by moment distribution. All moments are in K · ft.

7. Moment distribution factors (DF): For the exterior joint,

$$\text{DF (slab)} = \frac{K_s}{K_s + K_{ec}} = \frac{140}{140 + 192} = 0.42$$

$$\text{DF (columns)} = \frac{K_{ec}}{\sum K} = 0.58$$

The columns above and below the slab have the same stiffness; therefore, the distribution factor of 0.58 is divided equally between both columns, and each takes a DF of  $0.58/2 = 0.29$ . For the interior joint,

$$\text{DF (slab)} = \frac{K_s}{2K_s + K_{ec}} = \frac{140}{2 \times 140 + 192} = 0.295$$

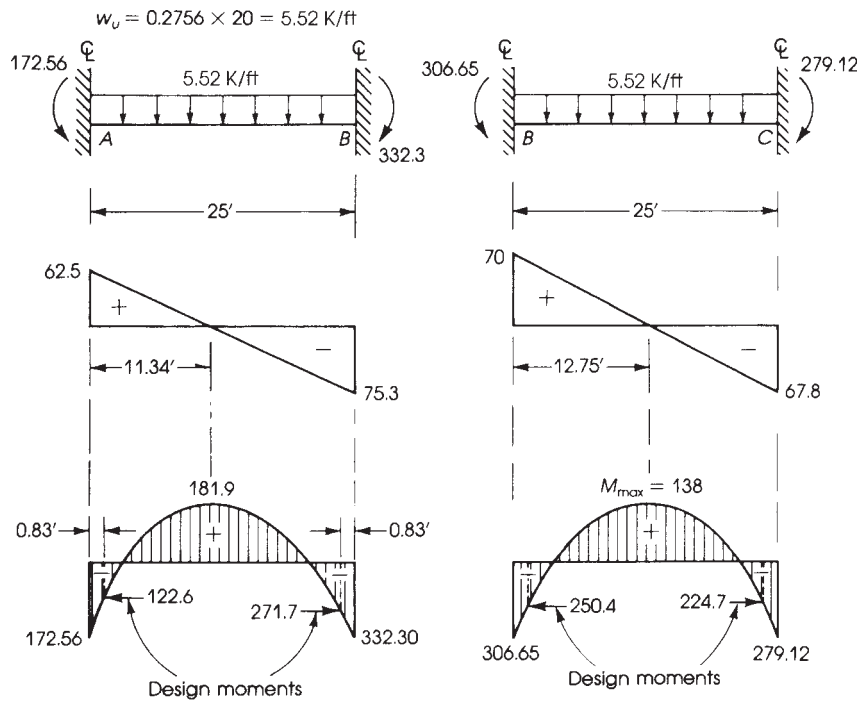
$$\text{DF (columns)} = \frac{K_{ec}}{\sum K} = \frac{192}{2 \times 140 + 192} = 0.41$$

Each column will have a DF of  $0.41/2 = 0.205$ .

8. Fixed-end moments: Because the actual LL/DL is less than 0.75, the full-factored load is assumed to act on all spans.

$$\text{Fixed - end moment} = k'' q_u l_2 (L_1)^2$$

The factor  $k''$  can be determined by the column analogy method: For a unit load  $w = 1.0$  K/ft over the longitudinal span of 25 ft, the simple moment diagram is shown in Fig. 17.38b. The area



$$V_A = 5.52 \times 12.5 - \frac{1}{25}(332.3 - 172.56) = 62.5 \text{ K}$$

$$V_B \text{ (left)} = 5.52 \times 12.5 + \frac{1}{25}(332.3 - 172.56) = 75.3 \text{ K}$$

$$V_B \text{ (right)} = 5.52 \times 12.5 + \frac{1}{25}(306.65 - 279.12) = 70 \text{ K}$$

$$V_C = 5.52 \times 12.5 - \frac{1}{25}(306.65 - 279.12) = 67.8 \text{ K}$$

**Figure 17.40** Example 17.13: Equivalent frame method— final bending moments and shear forces. (Slabs can be designed for the negative moments at the face of the columns as shown.)

of the bending moment diagram, considering the variation of the moment of inertia along the span, is

$$\begin{aligned} \text{Total area } (A_m) &= A_1 + A_2 + 2A_3 \\ &= \frac{2}{3} \times 23.33(78.1 - 10) + 23.33 \times 10 \\ &\quad + 2 \left( \frac{1}{2} \times 0.83 \times 10 \right) (0.84) = 1300 \end{aligned}$$

$$\text{Fixed - end moment coefficient} = \frac{A_m}{A_a I_1^2}$$

where  $A_a$  for the slab is 24.72, as calculated in step 3:

$$k'' = \frac{1300}{24.72(25)^2} = 0.084$$

It can be seen that the fixed-end moment coefficient,  $k'' = 0.084$ , is very close to the coefficient  $\frac{1}{12} = 0.0833$  usually used to calculate the fixed-end moments in beams. This is expected because the part of the span that has a variable moment of inertia is very small in flat plates where no column capital or drop panels are used. In this example, only parts  $AB$  and  $CD$ , each equal to 0.83 ft, have a higher moment of inertia than  $I_s$ . In flat plates where the ratio of the span to column width is high, say, at least 20, the coefficient 0.0833 may be used to calculate approximately the fixed-end moments. Fixed-end moment (due to  $q_u = 276$  psf)  $= 0.084(0.245)(20)(25)^2 = 256$  K · ft. The factors  $K$ ,  $K'_s$ , and  $K''$  can be obtained from tables prepared by Simmonds and Mistic [18] to meet the ACI requirements for the equivalent frame method.

9. Moment distribution can be performed on half the frame due to symmetry. Once the end negative moments are computed, the positive moments at the center of any span can be obtained by subtracting the average value of the negative end moments from the simple beam positive moment. The moment distribution is shown in Fig. 17.39. The final bending moments and shear forces are shown in Fig. 17.40.
10. Slabs can be designed for the negative moments at the face of the columns as shown in Fig. 17.40.

### Example 17.14 SI Units

Use the direct design method to design a typical interior flat slab with drop panels to carry a dead load of  $8.6$  kN/m<sup>2</sup> and a live load of  $11$  kN/m<sup>2</sup>. The floor system consists of six panels in each direction, with a panel size of  $6.0 \times 5.4$  m. All panels are supported by  $0.4$ -m-diameter columns with  $1.0$ -m-diameter column capitals. The story height is  $3.0$  m. Use  $f'_c = 28$  MPa and  $f_y = 400$  MPa.

### Solution

1. All the ACI limitations to using the direct design method are met. Determine the minimum slab thickness,  $h$ , using Eqs. 17.1 and Eqs. 17.2. The diameter of the column capital equals  $1.0$  m. The equivalent square column section of the same area will have a side of  $\sqrt{\pi r^2} = \sqrt{\pi(500)^2} = 885$  mm or  $900$  mm.

$$\text{Clear span (long direction)} = 6.0 - 0.9 = 5.1 \text{ m}$$

$$\text{Clear span (short direction)} = 5.4 - 0.9 = 4.5 \text{ m}$$

Because no beams are used  $\alpha_{fm} = 0$ ,  $\beta_s = 1.0$ , and  $\beta = 6.0 \text{ m}/5.4 \text{ m} = 1.11$ . From Table 17.1, minimum slab thickness  $h = l_n/33 = 5100/33 = 155$  mm, but because a drop panel is used,  $h$  may be reduced by 10% if drop panels extend a distance of at least  $l/6$  in each direction from the centerline of support and project below the slab a distance of at least  $h/4$ . Therefore, use a slab thickness  $h = 0.9 \times 155 = 140$  mm and a drop panel length and width as follows:

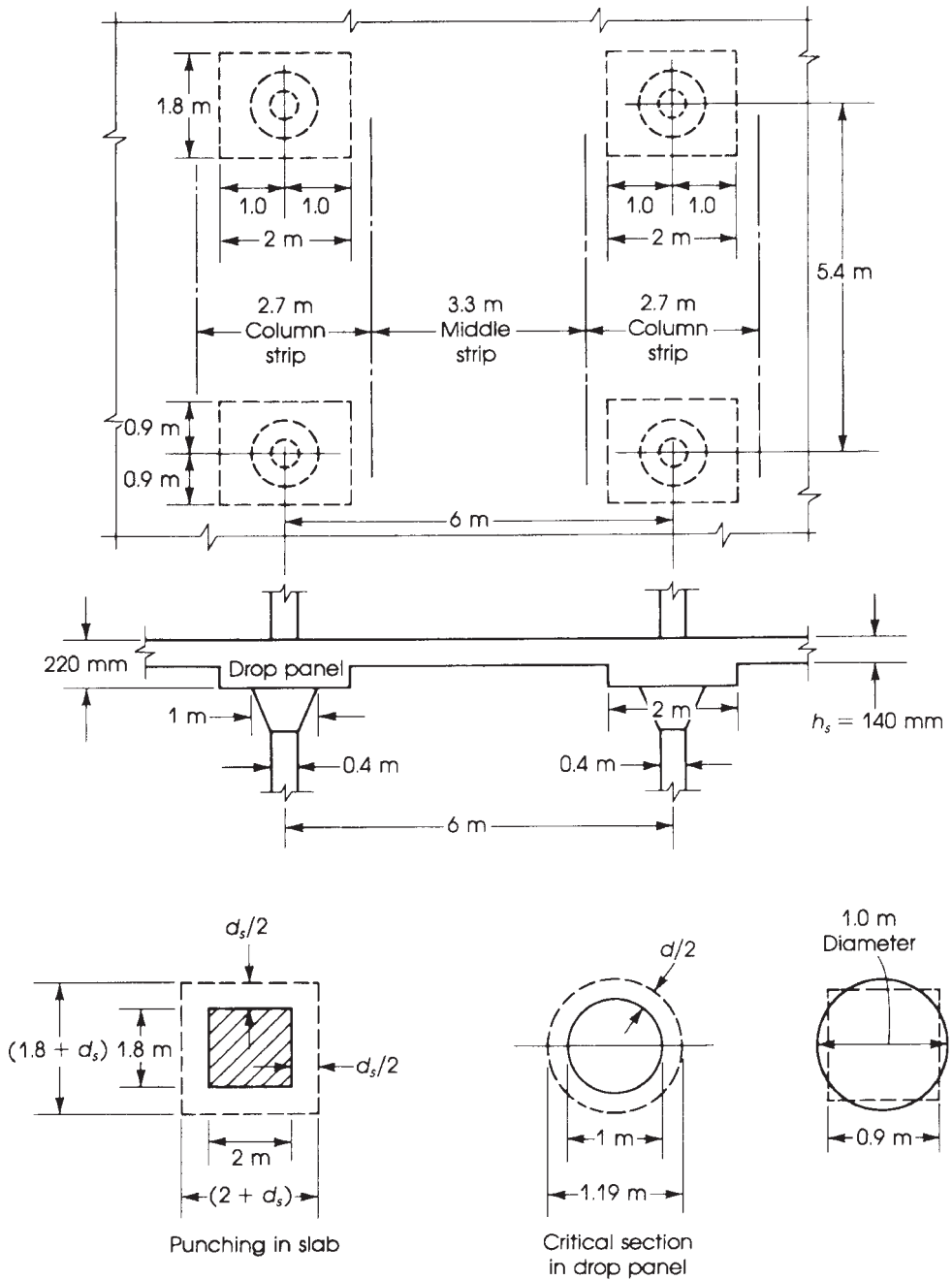
$$\text{Long direction } \frac{l_1}{3} = \frac{6.0}{3} = 2.0 \text{ m}$$

$$\text{Short direction } \frac{l_2}{3} = \frac{5.4}{3} = 1.8 \text{ m}$$

The thickness of the drop panel is  $1.25h = 1.25 \times 140 = 175$  mm. Increase drop panel thickness to  $220$  mm to provide adequate thickness for punching shear and to avoid the use of a high percentage of steel reinforcement. All dimensions are shown in Fig. 17.41.

2. Calculate factored loads:

$$q_u = 1.2 \times 8.6 + 1.6 \times 11 = 28 \text{ kN/m}^2$$



**Figure 17.41** Example 17.4: Interior flat slab with drop panel.

3. Check two-way shear, first in the drop panel: The critical section is at a distance  $d/2$  around the column capital. Let  $d = 220 - 30 \text{ mm} = 190 \text{ mm}$ . Diameter of shear section =  $1.0 \text{ m} + d = 1.19 \text{ m}$ :

$$V_u = 28 \left[ 6.0 \times 5.4 - \frac{\pi}{4} (1.19)^2 \right] = 876 \text{ kN}$$

$$b_0 = 2\pi \left( \frac{1.19}{2} \right) = 3.74 \text{ m}$$

$$\phi V_c = \phi \times 0.33 \times \sqrt{f'_c} b_0 d$$

$$= \frac{0.75 \times 0.33}{1000} \sqrt{28} \times 3740 \times 190 = 930 \text{ kN}$$

which is greater than  $V_u$  of 876 kN. Then check the two-way shear in the slab; the critical section is at a distance  $d/2$  outside the drop panel:

$$d(\text{slab}) = 140 - 30 = 110 \text{ mm}$$

$$\text{Critical area} = (2.0 + 0.11)(1.8 + 0.11) = 4.03 \text{ m}^2$$

$$b_0 = 2(2.11 + 1.91) = 8.04 \text{ m}$$

$$V_u = 28(6 \times 5.4 - 4.03) = 794 \text{ kN}$$

$$\phi V_c = \frac{0.75 \times 0.33}{1000} \sqrt{28} \times 8040 \times 110 = 1003 \text{ kN} > V_u$$

One-way shear is not critical.

4. Calculate the total static moments in the long and short directions:

$$M_{0l} = \frac{q_u}{8} l_2 l_{n1}^2 = \frac{28}{8} (5.4)(5.1)^2 = 491.6 \text{ kN} \cdot \text{m}$$

$$M_{0s} = \frac{q_u}{8} l_1 l_{n2}^2 = \frac{28}{8} (6)(4.5)^2 = 425.2 \text{ kN} \cdot \text{m}$$

Because  $l_2 < l_1$ , the width of the column strip in the long direction is  $2(0.25 \times 5.4) = 2.7 \text{ m}$ . The width of the column strip in the short direction is  $2.7 \text{ m}$ . Assuming that the steel bars are 12 mm in diameter and those in the short direction are placed on top of the bars in the long direction, then the effective depth in the short direction will be about 10 mm less than the effective depth in the long direction. The  $d$  values and the design procedure are shown in Table 17.14. Minimum lengths of the selected reinforcement bars should meet the ACI Code length requirements shown in Fig. 17.16. Note that all steel ratios are less than  $\rho_{\max}$ . Thus,  $\phi = 0.9$ .

5. The column stiffness is

$$\text{Ratio} \frac{\text{DL}}{\text{LL}} = \frac{8.6}{11} = 0.782 \quad \text{and} \quad \frac{l_1}{l_2} = 1.11$$

Determine  $\alpha_{\min}$  from Section 17.6, taking into account that the relative beam stiffness is 0 because no beams are used. By interpolation,  $\alpha_{\min} = 1.15$ . An approximate method is used here to determine the stiffness of the column with its capital.

$I_s$  (moment of inertia of slab, short direction)

$$= 6000 \frac{(140)^3}{12} = 1372 \times 10^6 \text{ mm}^4$$

$$K_s = \frac{4E_{cs} I_s}{l_2} = \frac{4E_{cs} \times 1372 \times 10^6}{5400} = 1016 \times 10^3 E_{cs}$$

**Table 17.14** Design of an Interior Flab Slab with Drop Panels

$M_0 = 491.6 \text{ kN} \cdot \text{m}$				
$M_n = +0.35M_0 = -319.5 \text{ kN} \cdot \text{m}$				
$M_p = +0.35M_0 = +172.1 \text{ kN} \cdot \text{m}$				
Long Direction	Column Strip		Middle Strip	
Moment factor	$0.75M_0$	$0.60M_p$	$0.25M_n$	$0.40M_p$
$M_u$ (kN·m)	-239.6	$\pm 103.3$	-79.9	$\pm 68.8$
$d$ (mm)	190	110	110	110
Strip width $b$ (m)	2.7	2.7	2.7	2.7
$R_u = \frac{M_u}{bd^2}$ (MPa)	2.46	3.16	2.44	2.10
Steel ratio, $\rho$ (%)	0.71	0.93	0.7	0.6
$A_s = \rho bd$ (mm <sup>2</sup> )	3642	2762	2079	1782
Min. $A_s = 0.0018bh$ (mm <sup>2</sup> )	1070	680	680	680
Bars selected (straight bars)	18 × 16 mm	14 × 16 mm	20 × 12 mm	16 × 12 mm
Spacing (mm)	150	193	135	170
$M_0 = 425.2 \text{ kN} \cdot \text{m}$				
$M_n = -0.65M_0 = -276.4 \text{ kN} \cdot \text{m}$				
$M_p = +0.35M_0 = +148.8 \text{ kN} \cdot \text{m}$				
Short Direction	Column Strip		Middle Strip	
Moment factor	$0.75M_n$	$0.60M_p$	$0.25M_n$	$0.40M_p$
$M_u$ (kN·m)	-207.3	$\pm 89.3$	-69.1	$\pm 59.5$
$d$ (mm)	180	100	100	100
Strip width $b$ (m)	2.7	2.7	3.3	3.3
$R_u = \frac{M_u}{bd^2}$ (MPa)	2.37	3.30	2.10	1.80
Steel ratio, $\rho$ (%)	0.69	1.00	0.6	0.5
$A_s = \rho bd$ (mm <sup>2</sup> )	3353	2700	1980	1650
Min. $A_s = 0.0018bh$ (mm <sup>2</sup> )	1070	680	832	832
Bars selected (straight bars)	18 × 16 mm	14 × 16 mm	18 × 12 mm	16 × 12 mm
Spacing (mm)	150	195	185	205

$I_c$  (for circular column, diameter 400 mm)

$$= \frac{\pi D^4}{64} = \frac{\pi}{64} (400)^4 = 1257 \times 10^6 \text{ mm}^4$$

$$K_c = \frac{4E_{cb}I_c}{l_c} = \frac{4E_{cb} \times 1257 \times 10^6}{3000 \text{ mm}} = 1676 \times 10^3 E_{cb}$$

Ratio of column stiffness/slab stiffness (Assume  $E_{cb} = E_{cs}$ )

$$= \frac{K_c}{K_s} = \frac{1676 \times 10^3}{1016 \times 10^3} = 1.65$$

which is greater than  $\alpha_{\min}$  of 1.15. If  $I_s$  in the long direction is used, the calculated ratio of column to slab stiffness will be greater than 1.65. Therefore, the column is adequate.

- Determine the unbalanced moment in the column and check the shear stresses in the slab, as explained in Examples 17.8 and 17.9.

## SUMMARY

### Sections 17.1–17.5

1. A two-way slab is one that has a ratio of length to width less than 2. Two-way slabs may be classified as flat slabs, flat plates, waffle slabs, or slabs on beams.
2. The ACI Code specifies two methods for the design of two-way slabs: the direct design method and the equivalent frame method. In the direct design method, the slab panel is divided (in each direction) into three strips, one in the middle (referred to as the *middle strip*) and one on each side (referred to as *column strips*).

### Section 17.6

To control deflection, the minimum slab thickness,  $h$ , is limited to the values computed by Table 17.1 or Eqs. 17.1 and 17.2 and as explained in Examples 17.1 and 17.2.

### Section 17.7

For two-way slabs without beams, the shear capacity of the concrete section in one-way shear is

$$V_c = 2\lambda\sqrt{f'_c}bd \quad (17.33)$$

The shear capacity of the concrete section in two-way shear is

$$V_c = \left(2 + \frac{4}{\beta_c}\right)\lambda\sqrt{f'_c}b_0d \leq 4\sqrt{f'_c}b_0d \quad (17.34)$$

When shear reinforcement is provided,  $V_n \leq 6\sqrt{f'_c}b_0d$ .

### Section 17.8

In the direct design method, approximate coefficients are used to compute the moments in the column and middle strips of two-way slabs. The total factored moment is

$$M_0 = (q_u l_2) \frac{l_1^2}{8} \quad (\text{Eq. 17.11})$$

The distribution of  $M_0$  into negative and positive span moments is given in Fig. 17.14. A summary of the direct design method is given in Section 17.8.8. The modified stiffness method is explained in Section 17.8.7.

### Sections 17.9–17.11

1. Unbalanced loads on adjacent panels cause a moment in columns that can be computed by Eq. 17.22
2. Approximately 60% of the moment transferred to both ends of a column at a joint is transferred by flexure,  $M_f$ , and 40% is transferred by eccentric shear,  $M_v$ . The fraction of the unbalanced moment transferred by flexure,  $M_f$ , is  $\gamma_f M_u$ , where  $\gamma_f$  is computed from Eq. 17.25. The shear stresses produced by  $M_v$  must be combined with shear stresses produced by the shearing force  $V_u$ .
3. Waffle slabs are covered in Section 17.11.



**Section 17.12**

1. In the equivalent frame method, the building is divided into equivalent frames in two directions and then analyzed for all conditions of loadings. Example 17.13 explains this procedure.
2. Example 17.14 is an example of a two-way flat slab with drop panel (SI units).

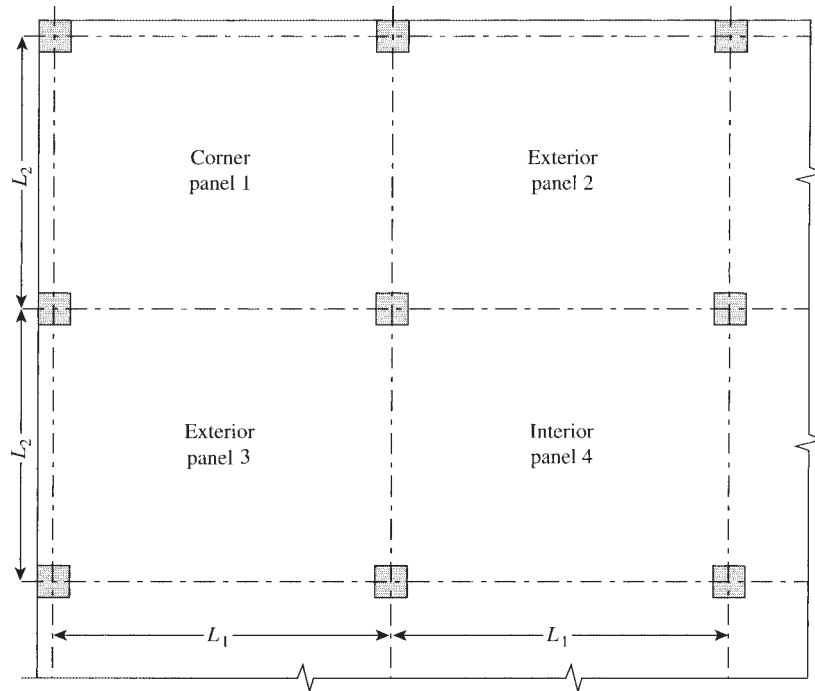
**REFERENCES**

1. Wy. G. Corley and J. O. Jirsa. "Equivalent Frame Analysis for Slab Design." *ACI Journal* 67 (November 1970).
2. W. L. Gamble. "Moments in Beam Supported Slabs." *ACI Journal* 69 (March 1972).
3. M. A. Sozen and C. P. Siess. "Investigation of Multipanel Reinforced Concrete Floor Slabs." *ACI Journal* 60 (August 1963).
4. W. L. Gamble, M. A. Sozen, and C. P. Siess. "Tests of a Two-Way Reinforced Concrete Slab." *Journal of Structural Division, ASCE* 95 (June 1969).
5. R. Park and W. Gamble. *Reinforced Concrete Slabs*. John Wiley, New York, 1980.
6. S. P. Timoshenko and S. W. Krieger. *Theory of Plates and Shells*, 2nd ed. McGraw-Hill, New York, 1959.
7. R. H. Wood. *Plastic and Elastic Design of Slabs and Plates*. Thames and Hudson, London, 1961.
8. O. C. Zienkiewicz. *The Finite Element Method in Engineering Science*. McGraw-Hill, New York, 1971.
9. K. W. Johansen. *Yield-Line Formulae for Slabs*. Cement and Concrete Association, London, 1972.
10. A. Hillerborg. *Strip Method of Design*. Cement and Concrete Association, London, 1975.
11. R. K. Dhir and J. G. Munday. *Advances in Concrete Slab Technology*. Pergamon, New York, 1980.
12. W. C. Schnorbrich. "Finite Element Determination of Non-Linear Behavior of Reinforced Concrete Plates and Shells." In *Proceedings of Symposium on Structural Analysis*, Transportation Road Research Lab, 164 VC. Crowthorne, UK, 1975.
13. M. Fintel (ed.). *Handbook of Concrete Engineering*. Van Nostrand Reinhold, New York, 1974.
14. American Concrete Institute (ACI). *Building Code Requirements of Structural Concrete*. ACI 318-14. ACI, Detroit, MI, 2014.
15. N. W. Hanson and J. M. Hanson. "Shear and Moment Transfer between Concrete Slabs and Columns." *PCA Journal* 10 (January 1968).
16. J. Moe. "Shear Strength of Reinforced Concrete Slabs and Footings under Concentrated Loads." *PCA Bulletin* D47 (April 1961).
17. *Brochure*. Molded Fiber Glass Concrete Forms Co. (MFG), Union City, PA, 1990.
18. S. H. Simmonds and J. Misic. "Design Factors for the Equivalent Frame Method." *ACI Journal* 68 (November 1971).
19. A. W. Hago and P. Bhatt. "Tests on Reinforced Concrete Slabs Designed by the Direct Design Method Procedure." *ACI Journal* 83 (November–December 1986).

**PROBLEMS**

- 17.1** (Flat plates) Determine the minimum slab thickness according to the ACI Code for the flat-plate panels shown in Fig. 17.42 and Table 17.15. The floor panels are supported by 24 × 24-in. columns, 12 ft long, with no edge beams at the end of the slab. Use  $f'_c = 4 \text{ ksi}$ ,  $f_y = 60 \text{ ksi}$ , dead load (excluding self-weight) = 55 psf, and live load = 120 psf.

- 17.2** (Flat plates) Use the direct design method to design the interior flat-plate panel (no. 4) of Problems a, b, c, and e, using the data given earlier. Check the shear and moment transfer at an interior column. Draw sketches showing the reinforcement distribution and the shear stresses.
- 17.3** (Flat plates) Repeat Problem 17.2 for the exterior panel no. 3. Check the shear and moment transfer at the exterior column. If shear stresses are not adequate, use shear reinforcement involving stirrups.
- 17.4** (Flat slabs with drop panels) Determine the minimum slab and drop panel thicknesses according to the ACI Code for the slabs shown in Fig. 17.42 and Table 17.15. The floor panels are supported by  $24 \times 24$ -in. columns with no edge beams. Use  $f'_c = 4$  ksi,  $f_y = 60$  ksi, additional dead load (excluding self-weight) = 60 psf, and live load = 120 psf.



**Figure 17.42** Problem 17.1.

**Table 17.15** Problem 17.1

Number (Flat Plate)	Panel Dimensions (ft)		Panel Numbers
	$L_1$	$L_2$	
a	20	20	1 and 4
b	24	24	2 and 4
c	26	26	3 and 4
d	20	16	1 and 2
e	24	20	3 and 4
f	26	22	1 and 4
g	30	24	1 and 2
h	30	30	1 and 4

- 17.5** (Flat slabs) Use the direct design method to design the interior flat slab panel no. 4, of Problem 17.4a, b, c, and e, using the data given in Problem 17.4. Check the shear and moment transfer at an interior column. Draw sketches showing the reinforcement distribution and the shear stresses. Use a 4-ft-column capital diameter for part *c* only.
- 17.6** (Flat slabs) Repeat Problem 17.5 for the exterior panel no. 3.
- 17.7** (Slabs on beams) Redesign the slabs in Problem 17.2, using the same data when the slabs are supported by beams on all four sides. Each beam has a width  $b_w = 14$  in. and a projection below the bottom of the slab of 18 in.
- 17.8** (Slabs on beams) Redesign the slabs in Problem 17.7 as exterior panels.
- 17.9** (Waffle slabs) Repeat Example 17.12 when the spans are (a) 36 ft and (b) 42 ft. Use the same data and  $24 \times 24$ -in. columns.
- 17.10** (Waffle slabs) Redesign the waffle slabs in Problem 17.9 as exterior panels.
- 17.11** (Equivalent frame method) Redesign the flat-plate floor system of Problem 17.2a and b using the equivalent frame method.
- 17.12** (Equivalent frame method) Redesign the waffle slabs of Problem 17.9 using the equivalent frame method.

# CHAPTER 18

## STAIRS



Office building under construction, Chicago, Illinois.

### 18.1 INTRODUCTION

Stairs must be provided in almost all buildings, either low-rise or high-rise buildings, even if adequate numbers of elevators are provided. Stairs consist of rises, runs (or treads), and landings. The total steps and landings are called a *staircase*. The *rise* is defined as the vertical distance between two steps, and the *run* is the depth of the step. The *landing* is the horizontal part of the staircase without rises (Fig. 18.1).

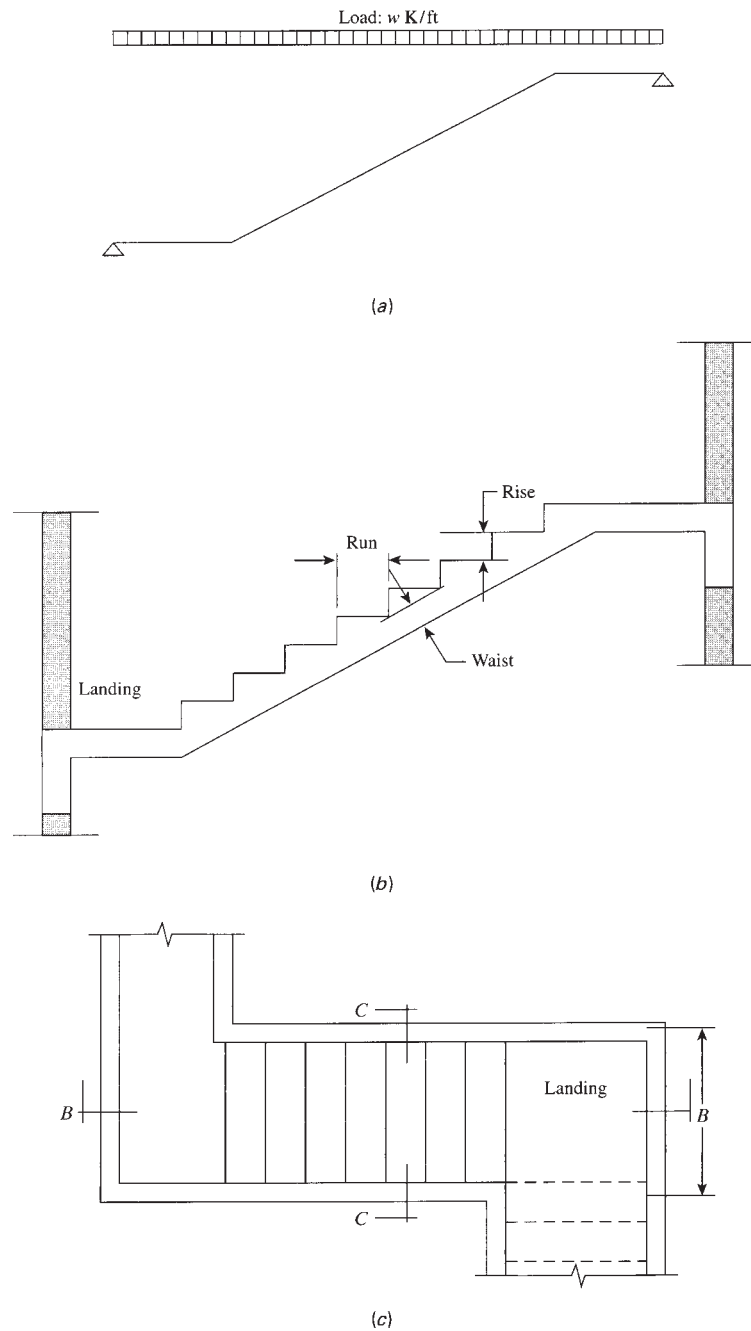
The normal dimensions of the rises and runs in a building are related by some empirical rules:

$$\text{Rise} + \text{run} = 17 \text{ in. (431 mm)}$$

$$2 \times \text{rise} + \text{run} = 25 \text{ in. (635 mm)}$$

$$\text{Rise} \times \text{run} = 75 \text{ in.}^2 (0.05 \text{ m}^2)$$

The rise depends on the use of the building. For example, in public buildings the rise is about 6 in., whereas in residential buildings it varies between 6 and 7.5 in. The run is about 1 ft in public buildings and varies between 9 and 12 in. in residential buildings. In general, a rise should not exceed 8 in. or be less than 4 in., and the number of rises is obtained by dividing the structural floor-to-floor dimension by the assumed rise.



**Figure 18.1** Plan of a single-flight staircase: (a) loads, (b) section B-B, and (c) plan.

The finishing on the stairs varies from troweling Alundum grits to adding asphalt tiles, terrazzo tiles, marble, or carpets. In addition to dead loads, stairs must be designed for a minimum live load of 100 psf.

## 18.2 TYPES OF STAIRS

There are different types of stairs, which depend mainly on the type and function of the building and on the architectural requirements. The most common types are as follows.

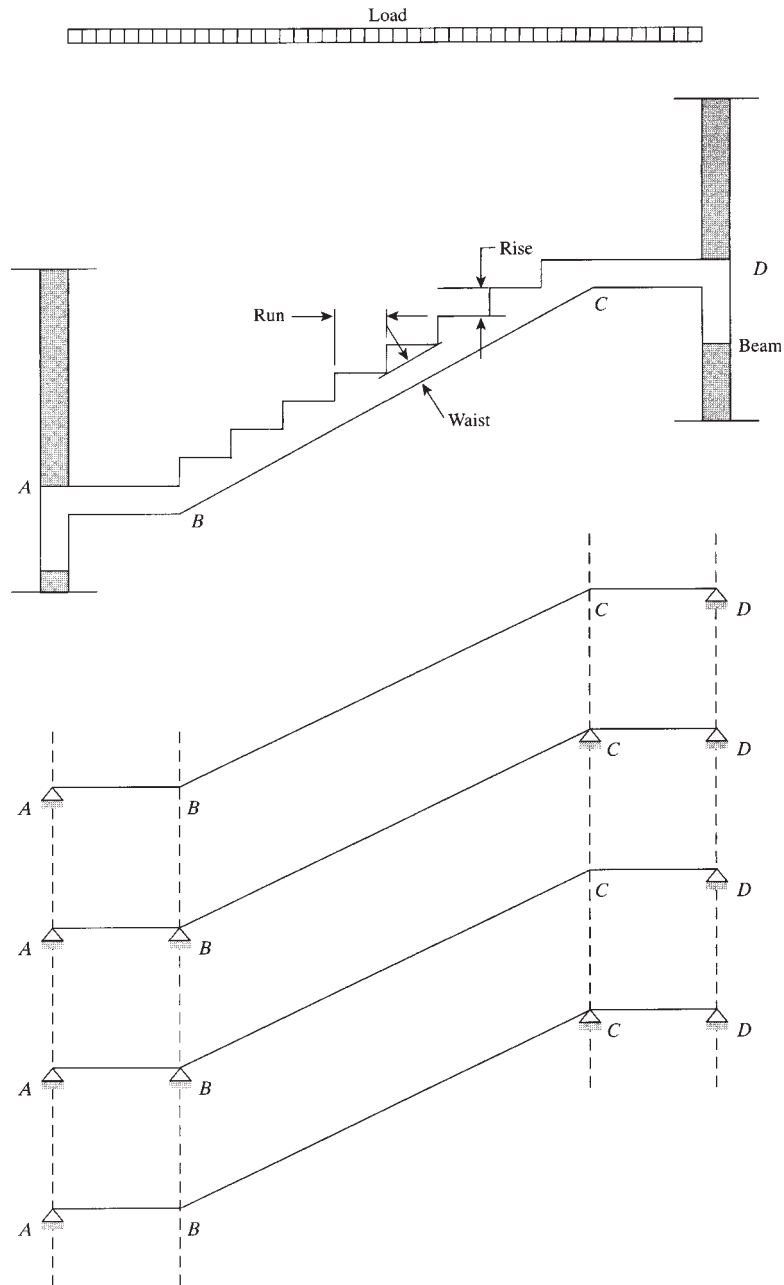
1. *Single-flight stairs*: The structural behavior of a flight of stairs is similar to that of a one-way slab supported at both ends. The thickness of the slab is referred to as the waist (Fig. 18.1). When the flight of stairs contains landings, it may be more economical to provide beams at  $B$  and  $C$  between landings (Fig. 18.2). If such supports are not provided, which is quite common, the span of the staircase will increase by the width of two landings and will extend between  $A$  and  $D$ . In residential buildings, the landing width is in the range of 4 to 6 ft, and the total distance between  $A$  and  $D$  is about 20 ft.

An alternative method of supporting a single flight of stairs is to use stringers, or edge beams, at the two sides of the stairs; the steps are then supported between the beams (Fig. 18.3).

2. *Double-flight stairs*: It is more convenient in most buildings to build the staircase in double flights between floors. The types commonly used are quarter-turn (Fig. 18.4) and closed- or open-well stairs, as shown in Fig. 18.5. For the structural analysis of the stairs, each flight is treated as a single flight and is considered supported on two or more beams, as shown in Fig. 18.2. The landing extends in the transverse direction between two supports and is designed as a one-way slab. In the case of open-well stairs, the middle part of the landing carries a full load, whereas the two end parts carry half-loading only, as shown in Fig. 18.5*d*. The other half-loading is carried in the longitudinal direction by the stair flights, sections  $A-A$  and  $B-B$ .
3. *Three or more flights of stairs*: In some cases, where the overall dimensions of the staircase are limited, three or four flights may be adopted (Fig. 18.6). Each flight will be treated separately, as in the case of double-flight staircases.
4. *Cantilever stairs*: Cantilever stairs are used mostly in fire escape stairs, and they are supported by concrete walls or beams. The stair steps may be of the full-flight type, projecting from one side of the wall, the half-flight type, projecting from both sides of the supporting wall, or of the semispiral type, as shown in Fig. 18.7. In this type of stairs, each step acts as a cantilever, and the main reinforcement is placed in the tension side of the run and the bars are anchored within the concrete wall. Shrinkage and temperature reinforcement is provided in the transverse direction.

Another form of a cantilever stair is that using open-riser steps supported by a central beam, as shown in Fig. 18.8. The beam has a slope similar to the flight of stairs and receives the steps on its horizontally prepared portions. In most cases, precast concrete steps are used, with special provisions for anchor bolts that fix the steps into the beam.

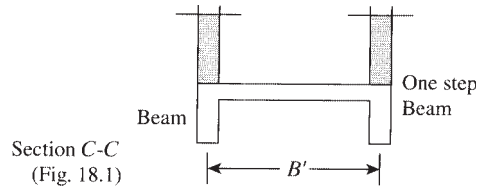
5. *Precast flights of stairs*: The speed of construction in some projects requires the use of precast flights of stairs (Fig. 18.8). The flights may be cast separately and then fixed to cast-in-place landings. In other cases, the flights, including the landings, are cast and then placed in position on their supporting walls or beams. They are designed as simply supported one-way slabs



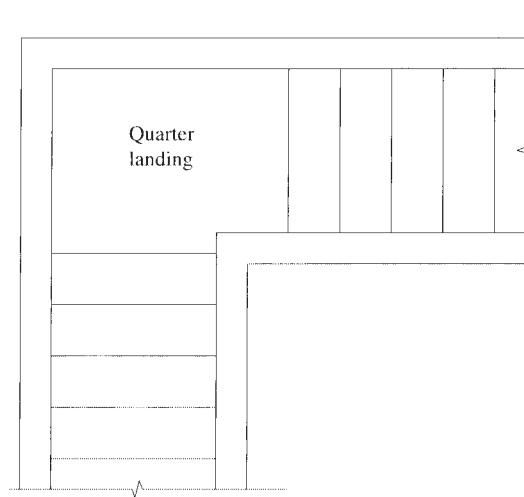
**Figure 18.2** Supporting systems of one flight.

with the main reinforcement at the bottom of the stair waist. Adequate reinforcement must be provided at the joints, as shown in Fig. 18.9.

Provisions must be made for lifting and handling the precast stair units by providing lifting holes or inserting special lifting hooks into the concrete. Special reinforcement must be



**Figure 18.3** Steps supported by stringer beams.



**Figure 18.4** Quarter-turn staircase.

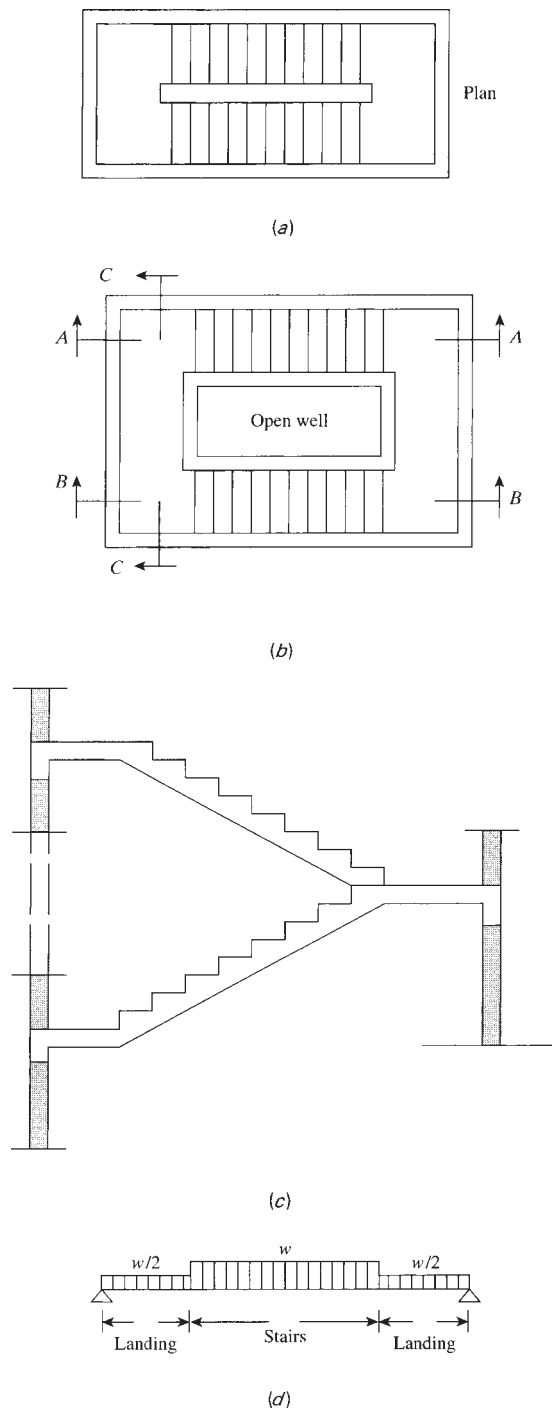
provided at critical locations to account for tensile stresses that will occur in the stairs from the lifting and handling process.

6. *Free-standing staircase*: In this type of stairs, the landing projects into the air without any support at its end (Fig. 18.10). The stairs behave in a springboard manner, causing torsional stresses in the slab.

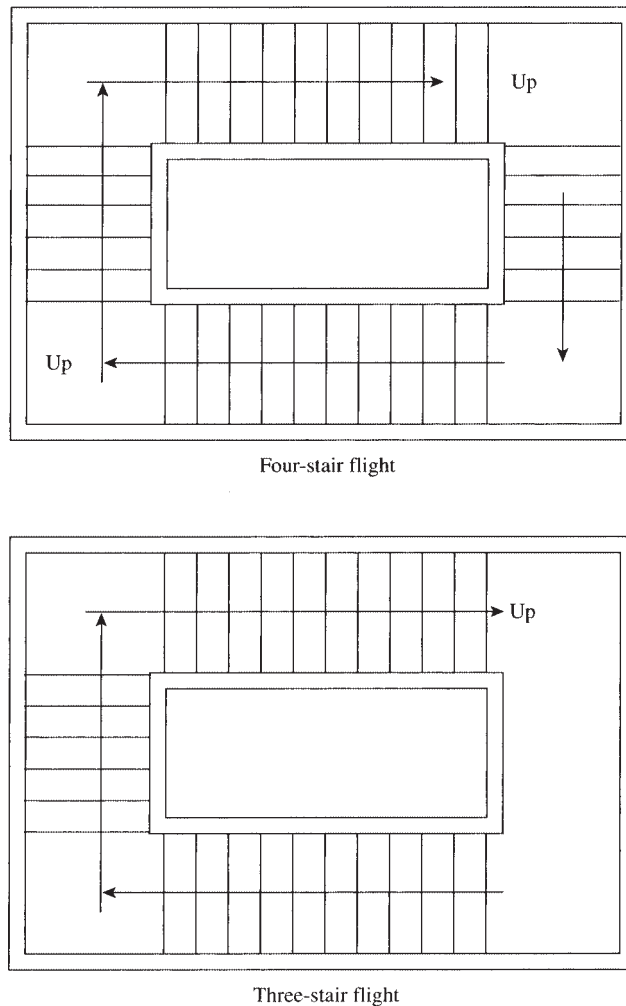
Three systems of loading must be considered in the design of this type of stairs, taking into consideration that torsional moments will develop in the slab in all cases:

- a. When the live load acts on the upper flight and half the landing only (Fig. 18.11), the upper flight slab will be subjected to tensile forces in addition to bending moments, whereas the lower flight will be subjected to compression forces, which may cause buckling of the slab.
- b. When the live load acts on the lower flight and half the landing only (Fig. 18.12), the upper flight slab will be subjected to tensile forces, whereas the lower flight will be subjected to bending moment and compression forces.
- c. When the live load acts on both upper and lower flights, the loading of one flight will cause the twisting of the other. The torsional stresses developed in the stairs require adequate reinforcement in both faces of the stair slabs and the landing. Transverse reinforcement in the slab and the landing must be provided in both faces of the concrete in the shape of closed U-bars lapping at midwidth of the stairs. Typical reinforcement details are shown in Fig. 18.13.





**Figure 18.5** Double-flight stairs: (a) closed-well staircase, (b) open-well staircase, (c) section B-B, and (d) section C-C.

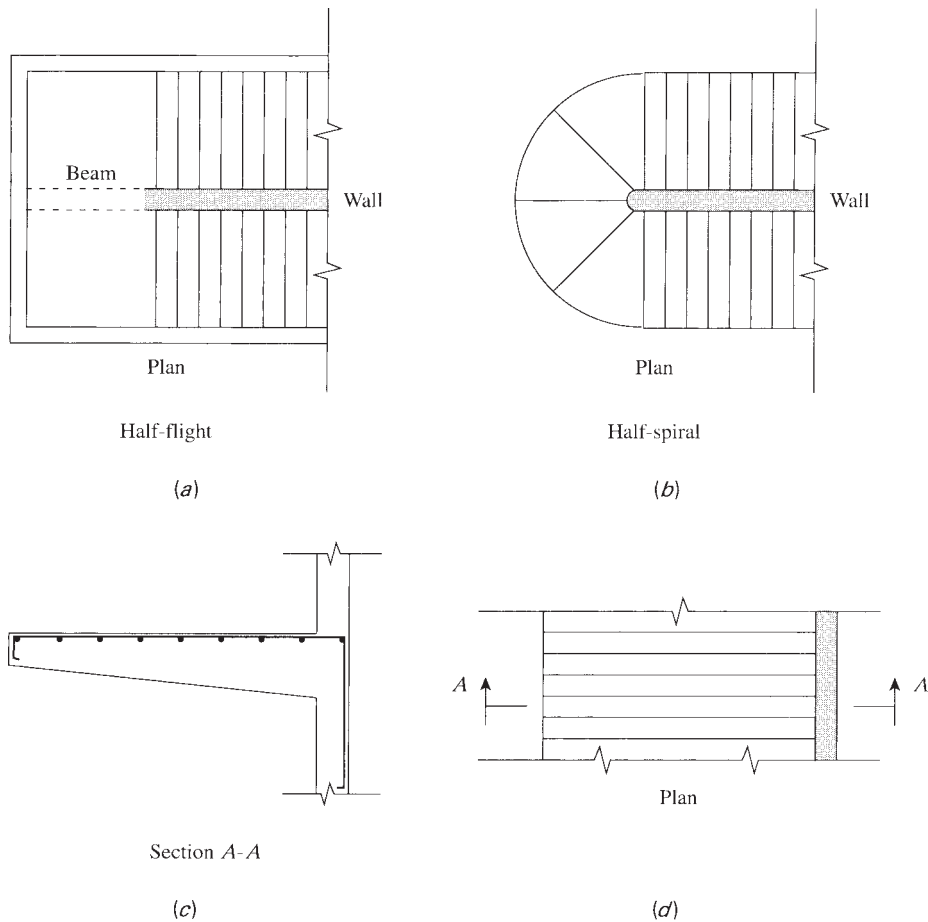


**Figure 18.6** Three- and four-stair flights.

This type of stairs is favored by architects and sometimes called a pliers-shaped staircase or jackknife staircase.

A study was made to determine the effect of the following parameters on the free-standing staircase forces and moments considering a live load of 100 psf (Figs. 18.10 and 18.13):

- i. *Width of stairs* (Fig. 18.10): An increase in the width from 4 to 10 ft, will increase the forces and moments sharply. For example, the torsional moment along the flight increases by about 1400%. Therefore, it is desirable to restrict the flight width between 4.0 and 6.0 ft. Other moments increase by about 450%.
- ii. *Span length  $L$* : An increase in the span  $L$  will increase the forces and moments in the stair flight and landing significantly. For example, if  $L$  is increased from 8 to 16 ft, the shearing forces at the top edge of the stairs increases by about 230%. Moments increase by about 100 to 150%.

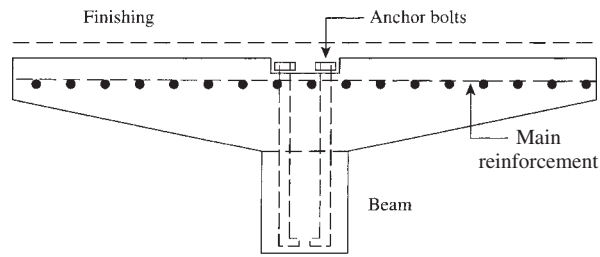


**Figure 18.7** Steps projecting from one or two sides of the supporting wall.

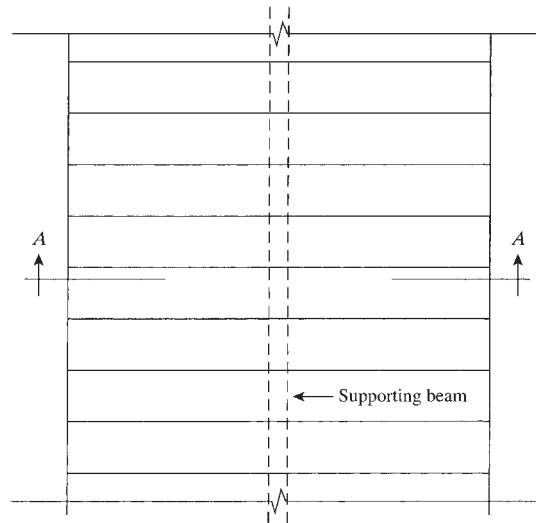
- iii. *Total flight height  $h$* : If  $h$  is increased from 10 to 16 ft, the shearing force at the top edge increases by about 150%. Moments increase by about 50 to 100%.
- iv. *Flight slab thickness  $t$* : This parameter has the least effect on forces and moments. For example, if  $t$  is increased from 6 to 10 in., the moments increase by about 25% and the shearing force by about 20%.
- v. For practical design, the parameters may be chosen as follows: flight width between 4 and 6 ft, horizontal span  $L$  between 9 and 12 ft, total flight height between 10 and 15 ft, and slab thickness between 6 and 10 in.

The preceding information is a guide to help the designer to choose the right parameters for an economical design.

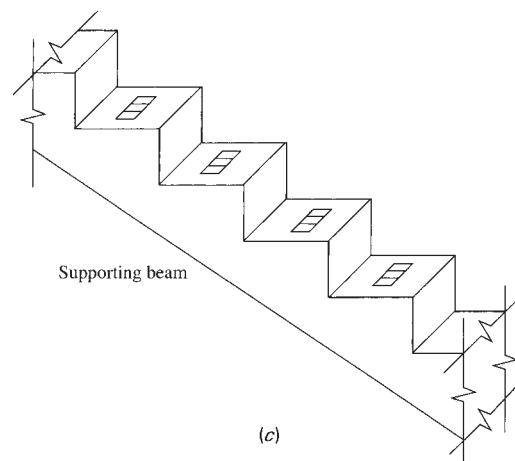
7. *Run-riser stairs*: Run-riser stairs are stepped underside stairs that consist of a number of runs and risers rigidly connected without the provision of the normal waist slab (Fig. 18.14a). This type of stairs has an elegant appearance and is sometimes favored by architects. The structural analysis of run-riser stairs can be simplified by assuming that the effect of axial forces is negligible and that the load on each run is concentrated at the end of the run (Fig. 18.14b).



(a)

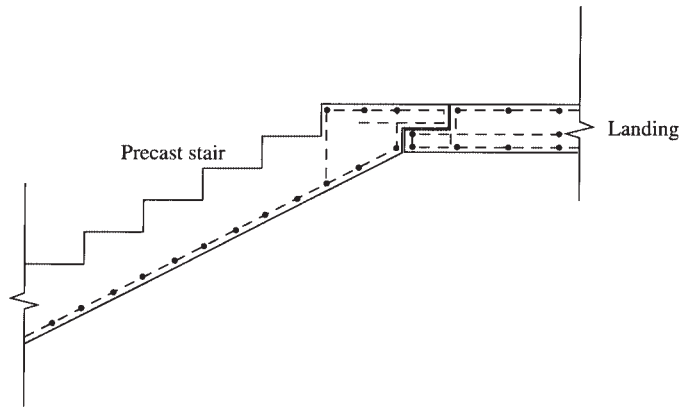


(b)

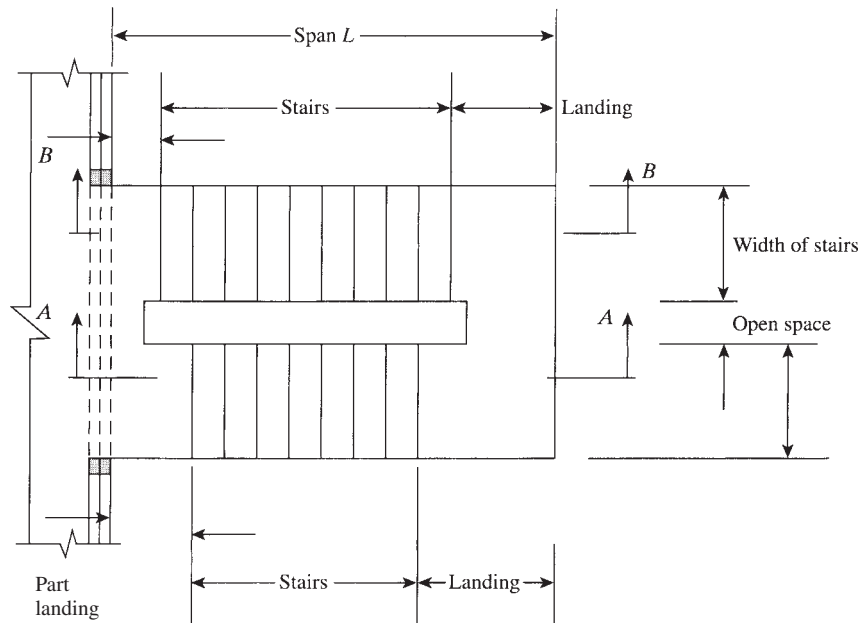


(c)

**Figure 18.8** Precast cantilever stair supported by central beam: (a) section A-A, (b) part plan, and (c) supporting beam.



**Figure 18.9** Joint of a precast concrete flight of stairs.



**Figure 18.10** Plan of a free-standing staircase.

For the analysis of a simply supported flight of stairs, consider a simple flight of two runs,  $ABC$ , subjected to a concentrated load  $P$  at  $B'$  (Fig. 18.14b). Because joints  $B$  and  $B'$  are rigid, the moment at joint  $B$  is equal to the moment at  $B'$ , or

$$M_B = M_{B'} = \frac{1}{2} PS$$

where  $S$  is the width of the run. The moment in rise,  $BB'$ , is constant and is equal to  $PS/2$ .

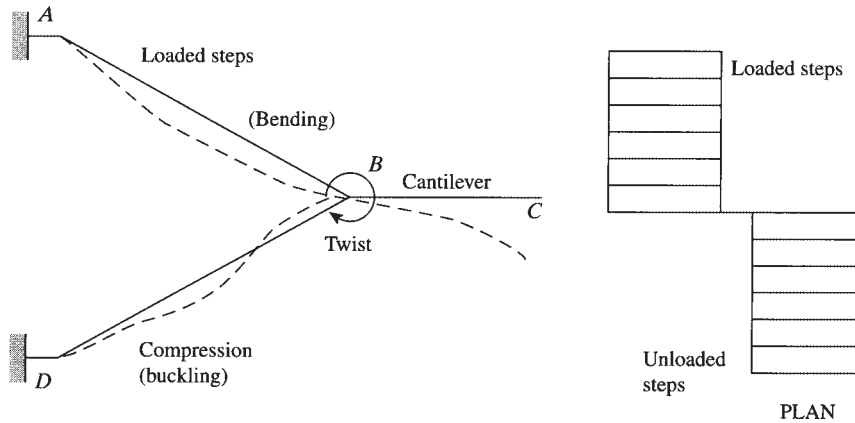


Figure 18.11 Case 1, ABC loaded.

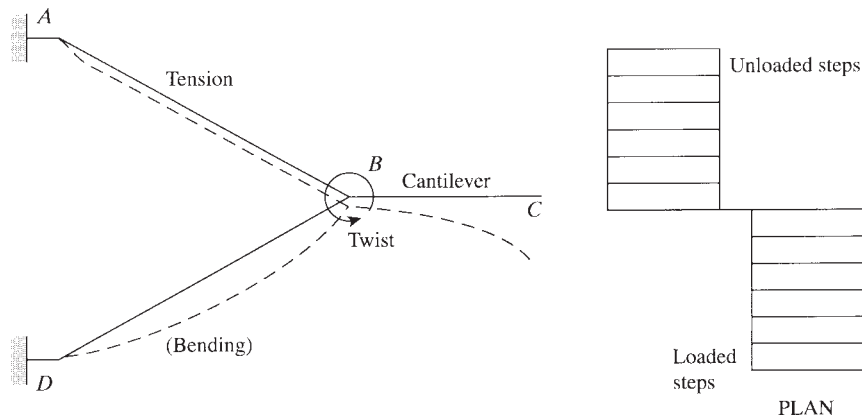


Figure 18.12 Case 2, DBC loaded.

When the rise is absent, the stairs,  $ABC$ , act as a simply supported beam, and the maximum bending moment occurs at midspan with value

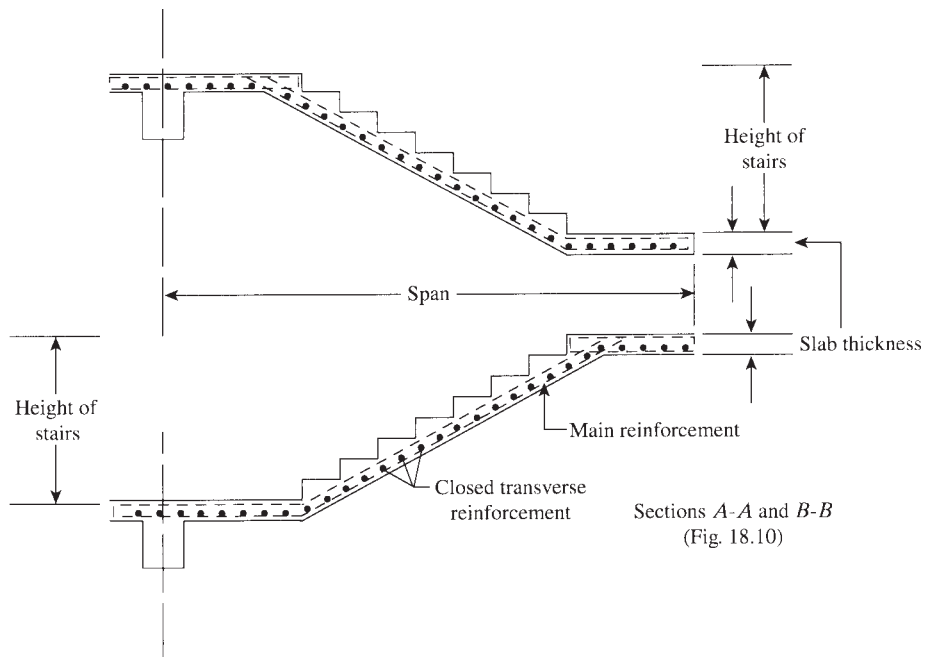
$$M_B = \frac{1}{4} PL = \frac{1}{2} PS$$

For a flight of stairs that consists of a number of runs and risers, the same approach can be used; the bending moment diagram is shown in Fig. 18.15a. The moment in  $BB'$  is constant and is equal to the moment at joint  $B$ , or  $2PS$ . Similarly,  $M_C = M'_C = 3PS$ ,  $M_D = M'_D = 3PS$ , and  $M_E = M'_E = 2PS$ .

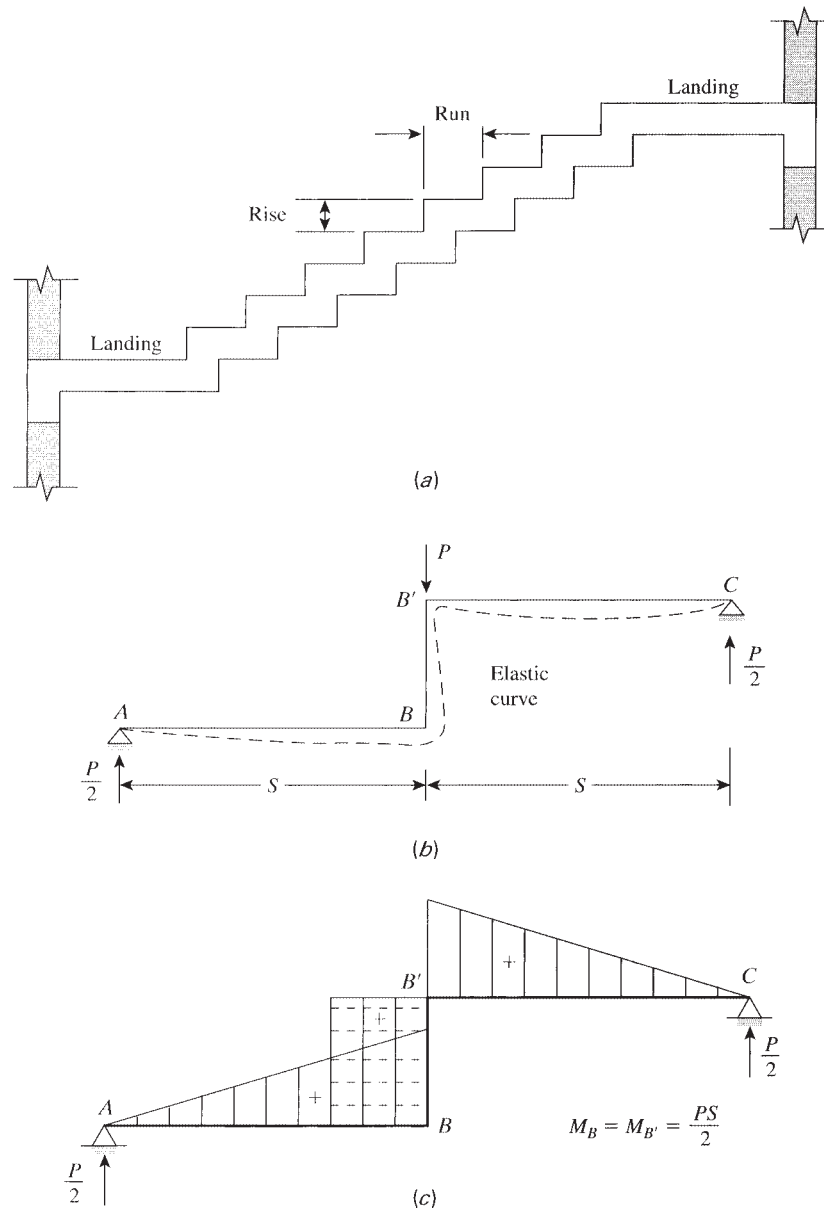
If a landing is present at one or both ends, the load on the landing practically may be represented by concentrated loads similar to the runs. The structural analysis may also be performed by considering a load uniformly distributed on the flight of stairs. The moment in every riser is constant and is obtained from the bending moment diagram of a simply supported beam subjected to a uniform load (Fig. 18.15b). Example 18.3 illustrates the design of a staircase using the two assumptions of concentrated loads and uniform loads.



Free-standing staircase.



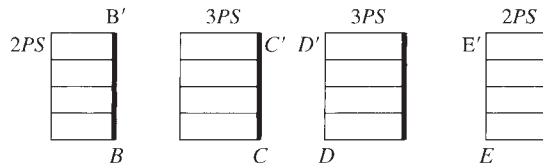
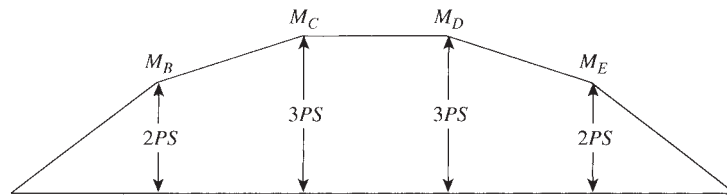
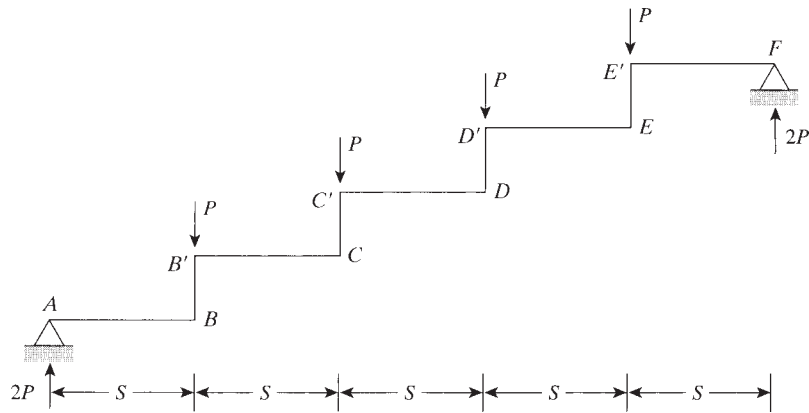
**Figure 18.13** Section of a free-standing staircase.



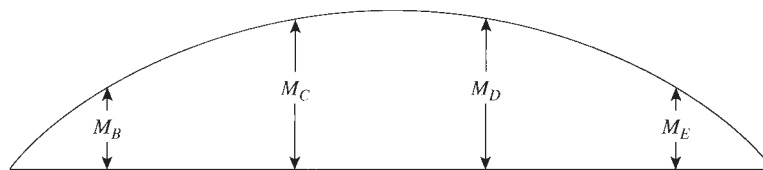
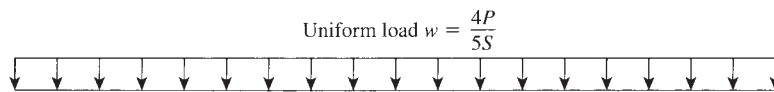
**Figure 18.14** Run-riser staircase: (a) cross section, (b) elastic curve, and (c) bending moment diagram.

If the stair flight is fixed or continuous at one or both ends, the moments can be obtained using any method of structural analysis. To explain this case, consider a flight of stairs that consists of two runs and is fixed at both ends (Fig. 18.16a). The moments at the fixed ends,  $A$  and  $B$ , due to a concentrated load at  $B$  are equal to  $PL/8 = PS/4$ . This result is obtained by assuming that the rise does not exist and the stairs,  $ABC$ , act as a fixed-end beam subjected



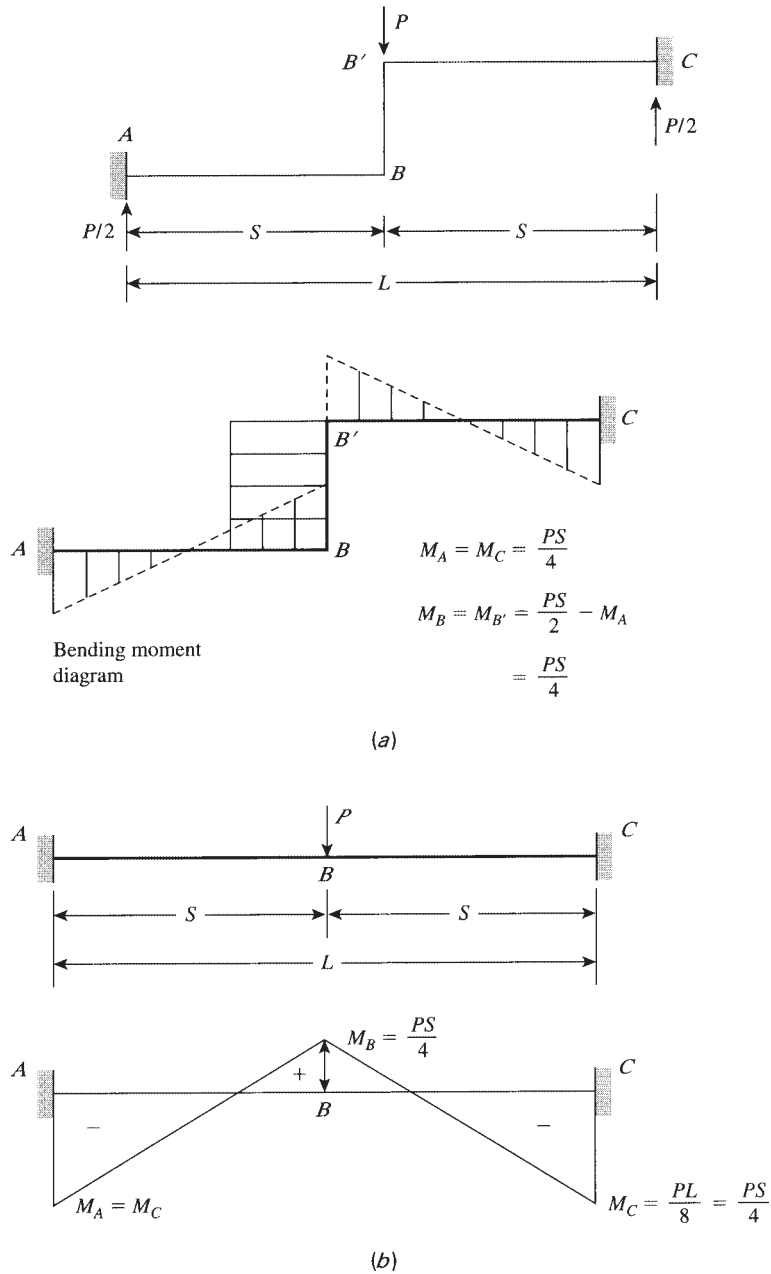


(a)



(b)

**Figure 18.15** Distribution of moments: (a) bending moment due to concentrated loads and (b) bending moment due to uniform load.



**Figure 18.16** Fixed-end staircase: (a) loaded steps and (b) loaded beam.

to a concentrated load at midspan (Fig. 18.16*b*). The moment at midspan, section *B*, is equal to

$$\frac{1}{4} PL - M_A = \frac{1}{2} PS - \frac{1}{4} PS = \frac{1}{4} PS$$

The bending moment of a flight of stairs with one riser is shown in Fig. 18.16*a*. Note that the moment in the riser *BB'* is constant, and  $M_B = M_{B'} = PS/4$ .

For a symmetrical stair flight, fixed at both ends and subjected to a number of concentrated loads at the node of each run, the moment at the fixed end can be calculated as follows:

$$M \text{ (fixedend)} = \frac{1}{12} PS(n^2 - 1)$$

where

- $P$  = concentrated load at node of run
- $S$  = width of run
- $N$  = number of runs

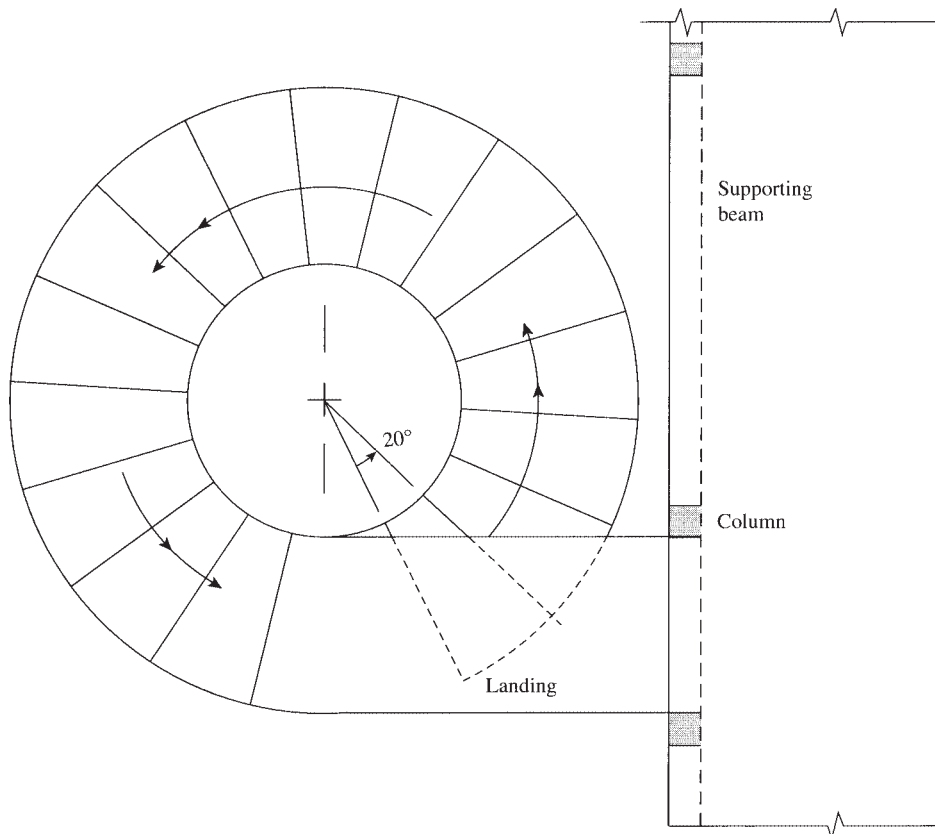
When  $n = 2$ , then

$$M \text{ (fixedend)} = \frac{1}{12} PS(4 - 1) = \frac{1}{4} PS$$

which is the same result obtained earlier.

If a landing is present at one or both ends, the load on the landing may be represented by concentrated loads at spacing  $S$ .

8. *Helical stairs (open-spiral stairs)*: A helical staircase is a three-dimensional structure, which usually has a circular shape in plan (Fig. 18.17). It is a distinctive type of stairs used mainly in entrance halls, theater foyers, and special low-rise office buildings. The cost of a helical stair is much higher than that of a normal staircase.



**Figure 18.17** Plan of a helical staircase (16 equal runs at 20° pitch).

The stairs may be supported at some edges within adjacent walls or may be designed as a free-standing helical staircase, which is most popular. The structural analysis of helical staircases is complicated and was discussed by Morgan [1] and Scordelis [2] using the principles of strain energy. Design charts for helical stairs are also prepared by Cusens and Kuang [3]. Under load, the flight slab will be subjected to torsional stresses throughout. The upper landing will be subjected to tensile stresses, whereas compressive stresses occur at the bottom of the flight. The forces acting at any section may consist of vertical moment, lateral moment, torsional moment, axial force, shearing force across the waist of the stairs, and radial horizontal shearing force. The main longitudinal reinforcement consists of helical bars placed in the concrete waist of the stairs and runs from the top landing to the bottom support. The transverse reinforcement must be in a closed stirrup form to resist torsional stresses or in a U-shape lapped at about the midwidth of the stairs.

A study was made to determine the effect of the following parameters on the forces and moments that develop on helical staircases. These parameters are:

1. The total arc subtended by the helix with an angle that normally ranges from  $240^\circ$  to  $360^\circ$ . Referring to Fig. 18.17, for 16 equal runs at  $20^\circ$  pitch, the total arc equals  $320^\circ$ . If the arc is increased from  $240^\circ$  to  $360^\circ$  the vertical moment may increase by about 1200% for a live load of 100 psf. Other forces increase appreciably.



Reinforced concrete helical staircase.

2. The width of stairs that normally ranges from 4 to 8 ft. All other parameters are constant. The increase of stair width by 100%, from 4 to 8 ft, increases the torsional moment by about 700%.
3. Variation in the interior and exterior radii ( $R_i$  and  $R_e$ ) keeping the stair width of 6 ft constant. The increase in  $R_e$  (from 9 to 12 ft) and  $R_i$  (from 3 to 6 ft) with a ratio of  $R_e/R_i$  that varies between 3 and 2, increases the lateral moment by about 230%.
4. The thickness of stair slab is not as critical as the other parameters. For a variation in slab thickness between 6 and 12 in., the lateral moment increases by about 70%, while the torsional moment increases by about 170%.
5. The total height of the helical stair,  $h$ , has the least effect on all forces (for  $h$  between 9 and 15 ft). The increase in lateral moment is about 70% and in torsional moment is about 40%. Other forces decrease by about 80%.
6. Based on this study, the possible practical dimensions may be chosen as follows: Total subtended arc between  $120^\circ$  and  $320^\circ$ , stair width between 4 and 6 ft, stairs slab thickness between 6 and 10 in., and stair height between 10 and 15 ft.

The above information can be used as a guide to achieve a proper and economical design of helical staircase.

An alternative method of providing a helical stair is to use a central helical girder located at the midwidth of the stairs and have the steps project equally on both sides of the girder. Each step is analyzed as a cantilever, and the reinforcement bars extend all along the top of the run. Precast concrete steps may be used and can be fixed to specially prepared horizontal faces at the top surfaces of the girder.

## 18.3 EXAMPLES

---

### Example 18.1

Design the cantilever stairs shown in Fig. 18.18 to carry a uniform live load of 100 psf. Assume the rise of the steps equals 6.0 in. and the run equals 12 in. Use normal-weight concrete with  $f'_c = 3$  ksi and  $f_y = 60$  ksi.

#### Solution

1. *Loads:* Assume the thickness of the slab (waist) is 4.0 in. Weight of the assumed slab (areas  $A_1$  and  $A_2$ ) is

$$\text{Trapezoidal area } mnm'm' = \left( \frac{4.9 + 10.9}{2 \times 12} \right) (1)(150) = 98.8 \text{ lb/ft}$$

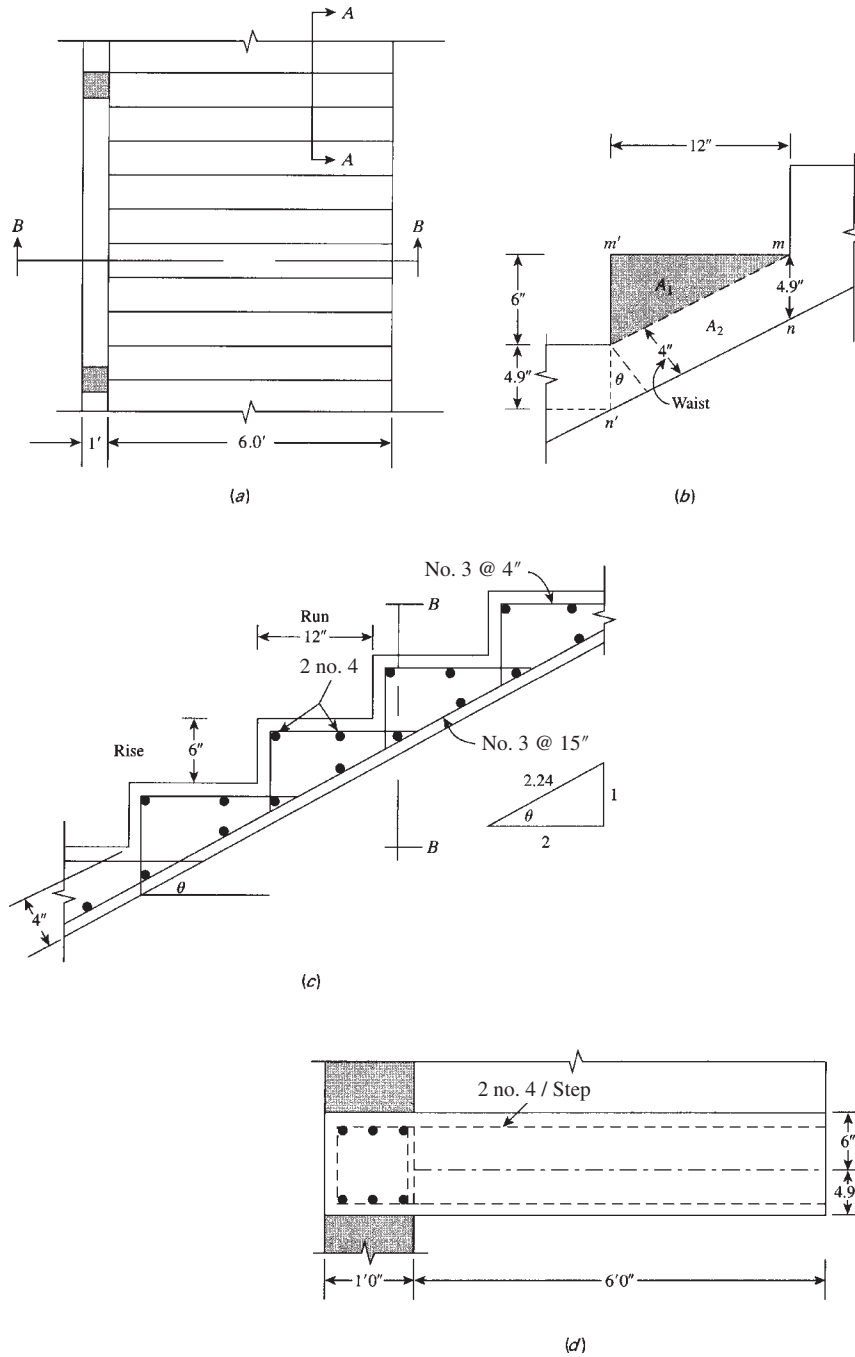
Refer to Fig. 18.18b. Assume the weight of the step cover is 5 lb/ft. Total DL = 103.8 lb/ft.

$$W_u = 1.2D + 1.6L = 1.2 \times 103.8 + 1.6 \times 100 = 285 \text{ lb/ft}$$

2. Maximum bending moment per step is  $W_u l^2/2$ .

$$M_u = \frac{0.285}{2} (6)^2 = 5.13 \text{ K} \cdot \text{ft}$$

Average thickness of a step is  $(10.9 + 4.9)/2 = 7.9$  in.



**Figure 18.18** Example 18.1: Cantilever stairs: (a) plan, (b) section in one step, (c) section A-A, and (d) section B-B.

Let  $d = 7.9 - 0.75$  (concrete cover)  $- 0.25$  ( $\frac{1}{2}$  bar diameter)  $= 6.9$  in.

$$M_u = \phi A_s f_y \left( d - \frac{1}{2} a \right) \quad (\text{assume } a = 0.5 \text{ in.})$$

$$A_s = \frac{5.13 \times 12}{0.9 \times 60(6.9 - 0.25)} = 0.17 \text{ in.}^2$$

Check

$$a = \frac{A_s f_y}{0.85 f'_c b} = \frac{0.17 \times 60}{0.85 \times 3 \times 12} = 0.33 \text{ in.} \quad (\text{close to } 0.4 \text{ in.})$$

$$\text{Minimum } A_s = 0.00333(12)(6.9) = 0.28 \text{ in.}^2$$

Use two no. 4 bars per step. A smaller depth may be adopted, but to avoid excessive deflection and vibration of stairs, a reasonable depth must be chosen.

3. Check flexural shear at a distance  $d$  from the face of the support:

$$V_u = 0.315 \left( 6 - \frac{6.9}{12} \right) = 1.7 \text{ K}$$

$$\phi V_c = 0.75(2\lambda\sqrt{f'_c}bd) = \frac{0.75}{1000} \times 2 \times 1 \times \sqrt{3000} \times 12 \times 6.9 = 6.8 \text{ K}$$

Because  $V_u < \phi V_c/2$ , no shear reinforcement is required. But it is recommended to use no. 3 stirrups spaced at 4 in. to hold the main reinforcement.

4. The stairs must remain in equilibrium either by the weight of the wall or by a reinforced concrete beam within the wall. In this case, the beam will be subjected to torsional moment of 5.13 K ft/ft.  
5. Reinforcement details are shown in Fig. 18.18.

### Example 18.2

Design the staircase shown in Fig. 18.19, which carries a uniform live load of 120 psf. Assume a rise of 7.0 in. and a run of 10.75 in. Use  $f'_c = 3$  ksi and  $f_y = 60$  ksi.

#### Solution

1. *Structural system:* If no stringer beam is used, one of the four possible solutions shown in Fig. 18.2 may be adopted. When no intermediate supports are used, the flight of stairs will be supported at the ends of the upper and lower landings. This structural system will be adopted in this example.  
2. *Loads:* Assume the thickness of the slab (waist) is 8.0 in.

$$\begin{aligned} \text{Weight of one step} &= \text{trapezoidal area} \times 150 \text{ pcf} \\ &= \left( \frac{9.5 + 16.5}{2 \times 12} \right) \left( \frac{10.75}{12} \right) (150) = 145.6 \text{ lb per step} \end{aligned}$$

$$\text{Average weight per foot length} = 145.6 \left( \frac{12}{10.75} \right) = 162.5 \text{ lb/ft}$$

$$\text{Weight of 8 in. landing} = \frac{8}{12} \times 150 = 100 \text{ lb/ft}$$

Assume the weight of the step cover is 7.5 lb/ft and weight of landing = 2 lb/ft. The total DL on stairs is  $162.5 + 7.5 = 170$  lb/ft. The total DL on landing is  $100 + 2 = 102$  lb/ft.

$$W_u(\text{on stairs}) = 1.2 \times 170 + 1.6 \times 120 = 400 \text{ lb/ft}$$

$$W_u(\text{on landing}) = 1.2 \times 102 + 1.6 \times 120 = 314 \text{ lb/ft}$$

Because the load on the landing is carried into two directions, only half the load will be considered in each direction.

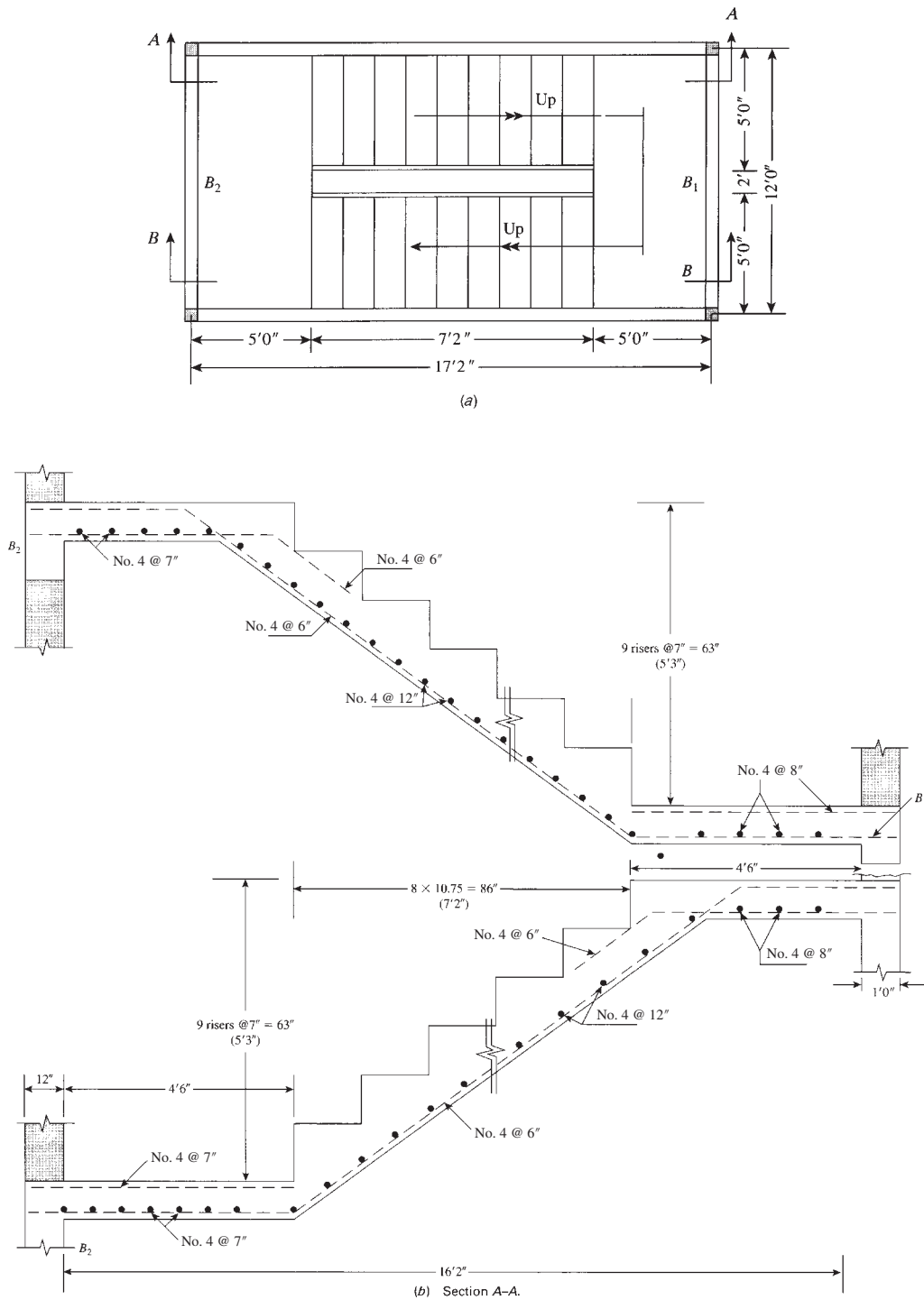


Figure 18.19 Example 18.2.



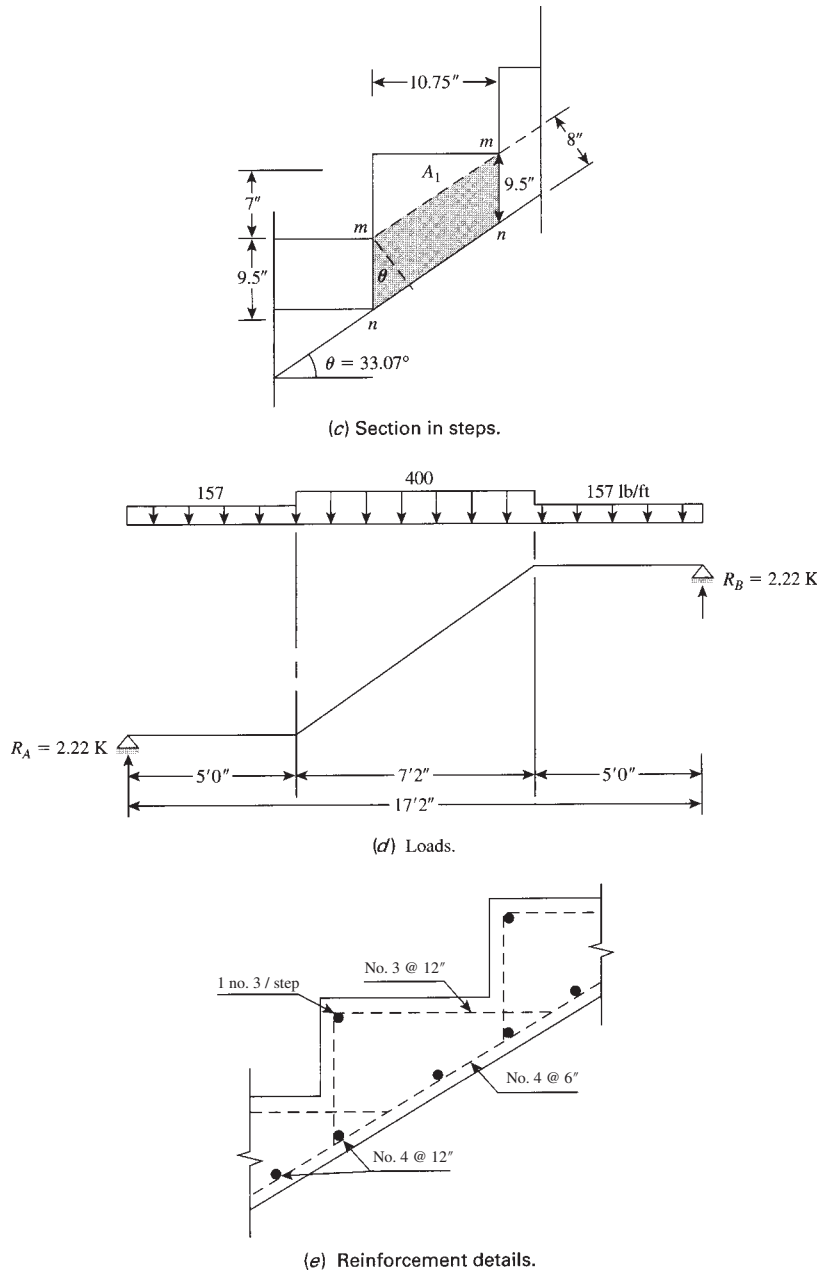


Figure 18.19 (Continued)

3. Calculate the maximum bending moment and steel reinforcement (Fig. 18.19d):  
 a. The moment at midspan is

$$M_u = 2.22 \left( \frac{17.2}{2} \right) - (0.157 \times 5)(6.1) - (0.400) \frac{(3.6)^2}{2} = 11.71 \text{ K} \cdot \text{ft}$$

$$\text{Let } d = 8.0 - 0.75 \text{ (concrete cover)} - 0.25 \left( \frac{1}{2} \text{ bar diameter} \right) = 7.0 \text{ in.}$$

- b.  $M_u = \phi A_s f_y (d - a/2)$ ; assume  $a = 0.8$  in.

$$A_s = \frac{11.71 \times 12}{0.9 \times 60(7 - 0.4)} = 0.4 \text{ in.}^2$$

Check:

$$a = \frac{A_s f_y}{0.85 f'_c b} = \frac{0.4 \times 60}{0.85 \times 3 \times 12} = 0.78 \text{ in.} \quad c = 0.92 \text{ in.}$$

$$\text{Minimum } A_s = 0.0033 \times 12 \times 8 = 0.32 \text{ in.}^2 < 0.4 \text{ in.}^2$$

Use no. 4 bars spaced at 6 in. ( $A_s = 0.4 \text{ in.}^2$ ). For 5-ft-wide stairs, use 10 no. 4 bars.

$$d_t = 7 \text{ in.} \quad c = 0.92 \text{ in.}$$

Net tensile strain,

$$\epsilon_t = \frac{d_t - c}{c} = 0.0198 \text{ in.}$$

$$\epsilon_t > 0.005 \quad \phi = 0.9$$

- c. Transverse reinforcement must be provided to account for shrinkage.

$$A_s = 0.0018 \times 12 \times 8 = 0.18 \text{ in.}^2/\text{ft}$$

Use no. 4 bars spaced at 12 in. ( $A_s = 0.2 \text{ in.}^2$ ).

- d. If the slab will be cast monolithically with its supporting beams, additional reinforcement must be provided at the top of the upper and lower landings. Details of stair reinforcement are shown in Fig. 18.19.

4. Minimum slab thickness for deflection is

$$\frac{L}{25} = \frac{17.2 \times 12}{25} = 8.26 \text{ in.}$$

(for a simply supported slab). In the case presented here, where the slab ends are cast with the supporting beams and additional negative reinforcement is provided, minimum thickness can be assumed to be

$$\frac{L}{28} = 7.4 \text{ in.} < 8 \text{ in. used}$$

5. *Design of landings:* Considering a 1-ft length of the landing, the load on the landing is as shown in Fig. 18.20. The middle 2 ft will carry a full load, whereas the two 5-ft lengths on each side will carry half the specified design load.

$$\text{Maximum bending moment} = (1.1 \times 6) - (0.157 \times 5)(3.5) - (0.314) \frac{(1)^2}{2} = 3.7 \text{ K} \cdot \text{ft}$$

Because the bars in the landing will be placed on top of the main stair reinforcement,

$$d = 8.0 - 0.75 - \frac{4}{8} - 0.25 = 6.375 \text{ in.} \quad \text{say, } 6.3 \text{ in.}$$

Assume  $a = 0.4$  in.

$$A_s = \frac{3.7 \times 12}{0.9 \times 60(6.3 - 0.2)} = 0.14 \text{ in.}^2 < A_s(\text{min}) \text{ of } 0.32 \text{ in.}^2$$

Use  $A_s = 0.32 \text{ in.}^2$ . Use no. 4 bars spaced at 7 in. ( $A_s = 0.34 \text{ in.}^2$ ).

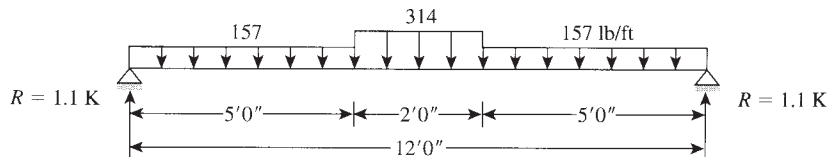


Figure 18.20 Example 18.2: Loads on landing.

6. The transverse beams at the landing levels must be designed to carry loads from stairs (2.3 K/ft) in addition to their own weight and the weight of the wall above.
7. Check shear as usual.

**Example 18.3**

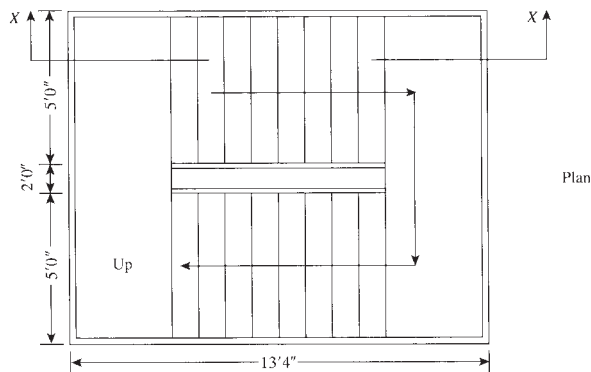
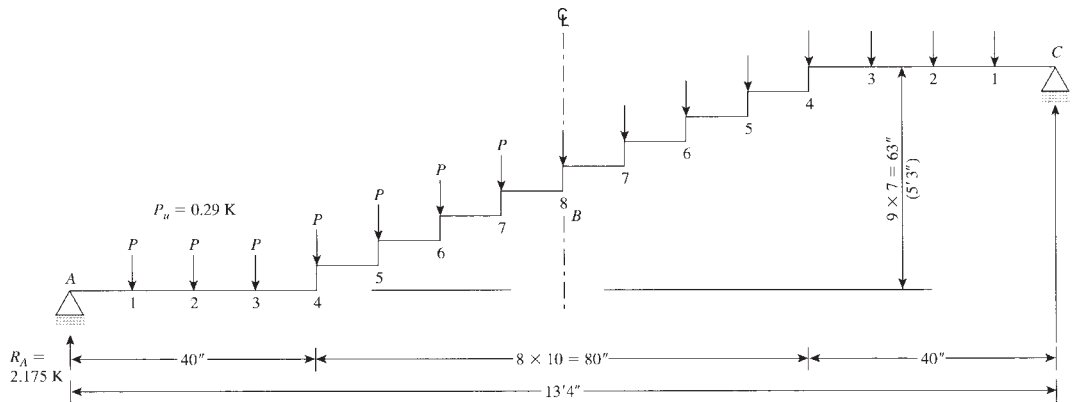
Design the simply supported run-riser stairs shown in Fig. 18.21 for a uniform live load of 120 psf. Use  $f'_c = 3$  ksi and  $f_y = 60$  ksi.

**Solution**

1. *Loads:* Assume the thickness of runs and risers is 6 in. The concentrated load at each riser is calculated as follows (refer to Fig. 18.21*b*). Due to dead load per foot depth of run,

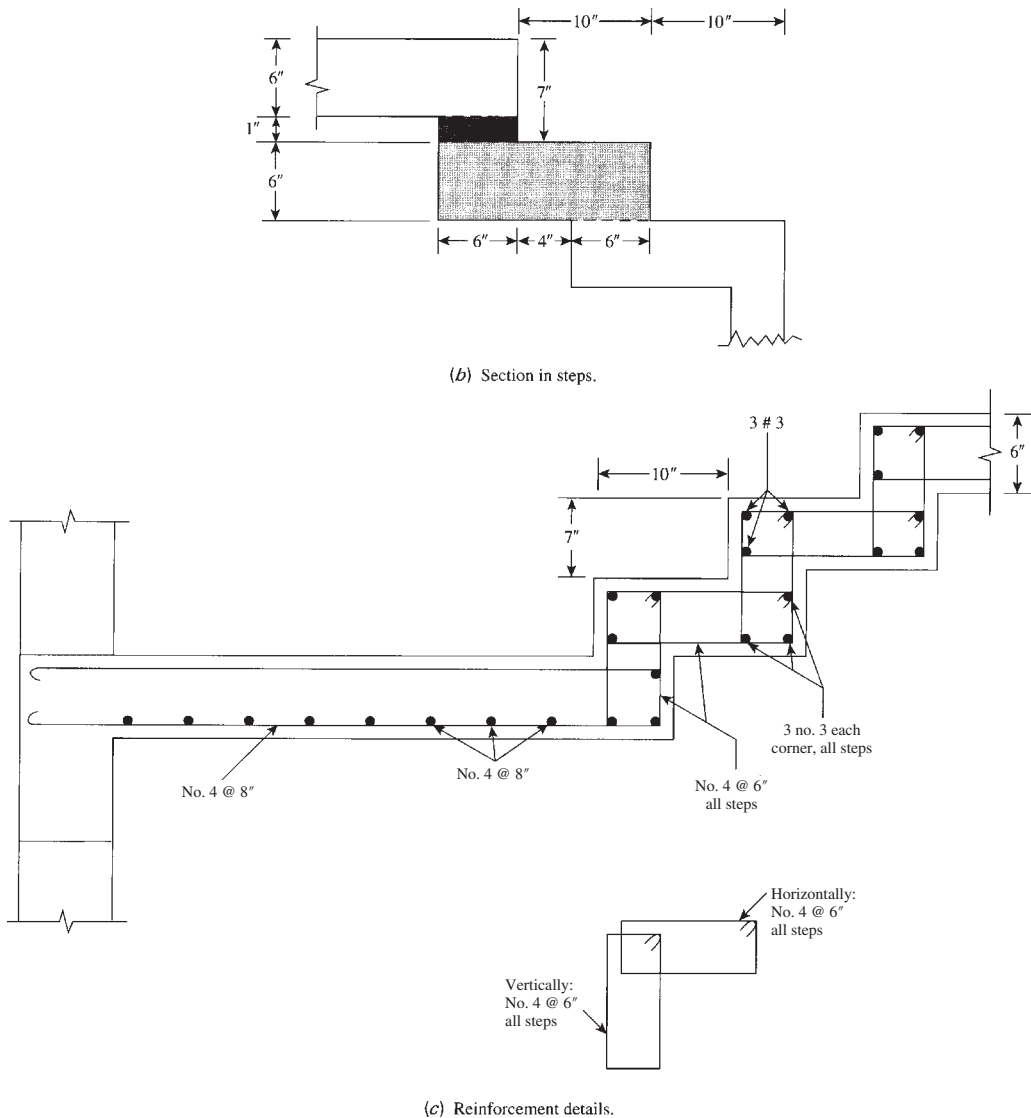
$$P_D = \left( \frac{16}{12} \times \frac{6}{12} + \frac{1}{12} \times \frac{6}{12} \right) 150 = 106 \text{ lb}$$

Note that the node dead load on the landing is less than 106 lb but can be assumed to be equal to  $P_D$  to simplify calculations. Due to live load per foot depth of run,  $P_L = \frac{10}{12} \times (120) = 100 \text{ lb}$ .



(a) Plan and section X-X

**Figure 18.21** Example 18.3.



**Figure 18.21** (Continued)

$$\begin{aligned} \text{Factored load, } P_u &= 1.2P_D + 1.6P_L \\ &= 1.2 \times 106 + 1.6 \times 100 = 290 \text{ lb} \end{aligned}$$

2. Calculate the bending moments at midspan: Loads in this example are symmetrical about midspan section *B*. Reaction at *A*,  $R_A$  is  $\frac{1}{2}(15)(290) = 2175 \text{ lb} = \left(7\frac{1}{2}P_u\right)$ .

$$\begin{aligned} \text{Moment at } B &= R_A(8S) - 7P_u(4S) \\ &= 2.175(8 \times 10) - 7(0.29)(4 \times 10) = 92.8 \text{ K} \cdot \text{in.} \end{aligned}$$

3. Calculate the reinforcement required at midspan section: For  $h = 6$  in.,  $d = 6 - 1.0 = 5.0$  in.,

$$R_u = \frac{M_u}{bd^2} = \frac{92.8 \times 1000}{12(5.0)^2} = 309 \text{ psi}$$

For  $f'_c = 3$  ksi,  $f_y = 60$  ksi, and  $R_u = 309$  psi, the steel ratio is  $\rho = 0.0061 < \rho_{\max} = 0.0135$  ( $\phi = 0.9$ ).

$$A_s = 0.0061 \times 12 \times 5.0 = 0.366 \text{ in.}^2$$

Use no. 4 bars spaced at 6 in. ( $A_s = 0.40 \text{ in.}^2$ ) horizontally and vertically in closed stirrup form. For distribution bars, use minimum  $\rho$  of 0.0018:

$$A_s = 0.0018 \times 16 \times 6 = 0.18 \text{ in.}^2$$

Use no. 3 bars spaced at 6 in. ( $A_s = 0.22 \text{ in.}^2$ ). For each step corner, use three no. 3 bars ( $A_s = 0.33 \text{ in.}^2$ ), as shown in Fig. 18.21c.

4. The moments and reinforcement required for other sections can be prepared in table form, as follows:

Location	A	1	2	3	4	5	6	7	8
BM (K in.)	0	22	41	57	70	80	87	91	92.8
$R_u$ (psi)	0	73	137	190	233	267	290	303	309
$\rho$ (%)	0	0.18	0.26	0.38	0.46	0.52	0.58	0.60	0.61
$A_s$ (in. <sup>2</sup> )	0	0.11	0.16	0.23	0.28	0.31	0.35	0.36	0.37

Use no. 4 bars at 8 in. for the landing and no. 4 bars at 6 in. for the steps. For distribution bars, use minimum  $\rho$  of 0.0018. For  $A_s = 0.18 \text{ in.}^2$ , use no. 4 bars spaced at 8 in. in the landing. Details of reinforcement are shown in Fig. 18.21c.

5. Check reinforcement required in the transverse direction of landing: Load per square foot on the landing is  $\frac{290}{10} \times 12 = 348$  psf.

$$M_u = \frac{0.348}{8}(12)^2 \times 12 = 75 \text{ K} \cdot \text{in.}$$

$$R_u = \frac{75 \times 1000}{12(5.0)^2} = 250 \text{ psi} \quad \rho = 0.0049 \quad A_s = 0.29 \text{ in.}^2$$

Use no. 4 bars spaced at 8 in. ( $A_s = 0.29 \text{ in.}^2$ ).

6. If a uniform load is assumed to be acting on the flight of stairs, similar results will be obtained. For example, design node load was calculated to be 290 lb acting over a 10-in. run width. Load per foot is  $\frac{290}{10} \times 12 = 348$  lb/ft. Maximum moment is at midspan, section B:

$$M_u = \frac{0.348}{8}(13.33)^2 = 92.8 \text{ K} \cdot \text{in.}$$

Moments at other sections can be easily calculated, and the design can be arranged in a table form, as explained in step 4.

## SUMMARY

### Sections 18.1 and 18.2

The different types of stairs are single and multiple flights, cantilever and precast concrete flights, free-standing and helical staircases, and run-riser stairs.

### 18.4.2. Section 18.3

Design examples are presented in this section.

## REFERENCES

1. V. A. Morgan, "Comparison of Analyses of Helical Stairs." *Concrete and Constructional Engineering*, London (March 1960): 127–132.
2. A. C. Scordelis, "Internal Forces in Uniformly Loaded Helicoidal Girders." *Journal of the American Concrete Institute* (April 1960).
3. A. R. Cusens and Jing-gwo Kuang. "A Simplified Method of Analyzing Free Standing Stairs." *Concrete & Constructional Engineering* (May 1965): 167–172.
4. A. R. Cusens and Jing-gwo Kuang. "Experimental Study of a Free Standing Staircase." *Journal of the American Concrete Institute* (May 1966): 587–603.
5. Franz Sauter. "Free Standing Stairs." *Journal of the American Concrete Institute* (July 1961): 847–869.
6. Cusens and Santathadapon. *Design Charts for Helical Stairs with Fixed Supports*. Concrete Publications, London, 1966.
7. A. H. Mattock. "Design and Construction of a Helical Staircase." *Concrete & Constructional Engineering* (March 1957): 99–105.

## PROBLEMS

- 18.1** Design a typical flight of the staircase shown in Fig. 18.22, which is a part of a multistory building. The height between the concrete floors is 10 ft (3.0 m). The stairs are supported at the ends of the landings and carry a live load equal to 120 psf (5.75 kN/m<sup>2</sup>);  $f'_c = 3$  ksi (20 MPa) and  $f_y = 60$  ksi (400 MPa).

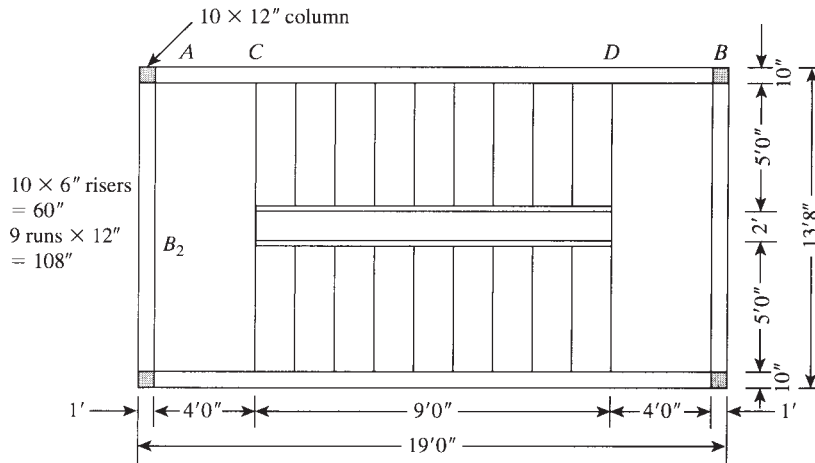


Figure 18.22 Problem 18.1.

- 18.2** Repeat Problem 18.1 if the stairs are supported by four transverse beams at A, B, C, and D and the live load is increased to 150 psf (7.2 kN/m<sup>2</sup>).
- 18.3** The stairs shown in Fig. 18.23 are to be designed for a live load equal to 100 psf (4.8 kN/m<sup>2</sup>). The stairs are supported by beams, as shown. Design the stairs and the supporting beams for  $f'_c = 3$  ksi (20 MPa) and  $f_y = 60$  ksi (400 MPa).

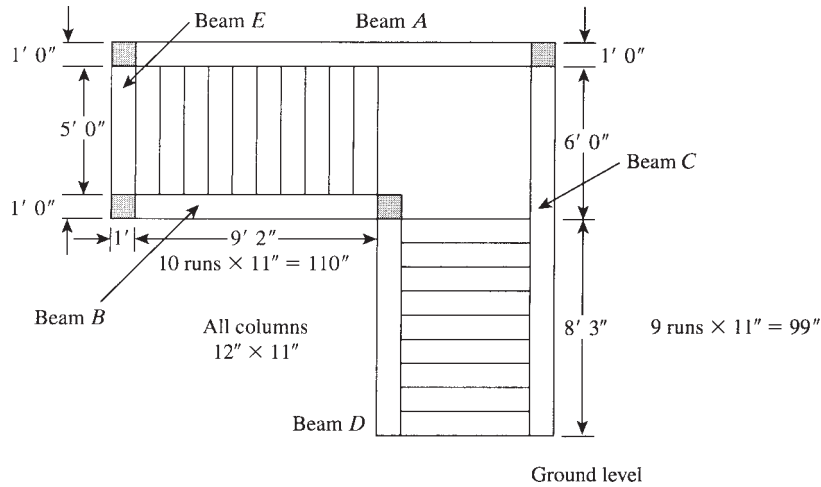


Figure 18.23 Problem 18.3.

**18.4** Design a typical flight of stairs in a public building for the staircase arrangement shown in Fig. 18.24. The stairs are supported by central beams, A and B. Design only one flight and the supporting beams A and B. The runs are 1.0 ft (300 mm) deep and the rises are 6.5 in. high. Use  $f'_c = 3$  ksi (20 MPa),  $f_y = 60$  ksi (400 MPa), and a live load equal to 80 psf (3.85 kN/m<sup>2</sup>).

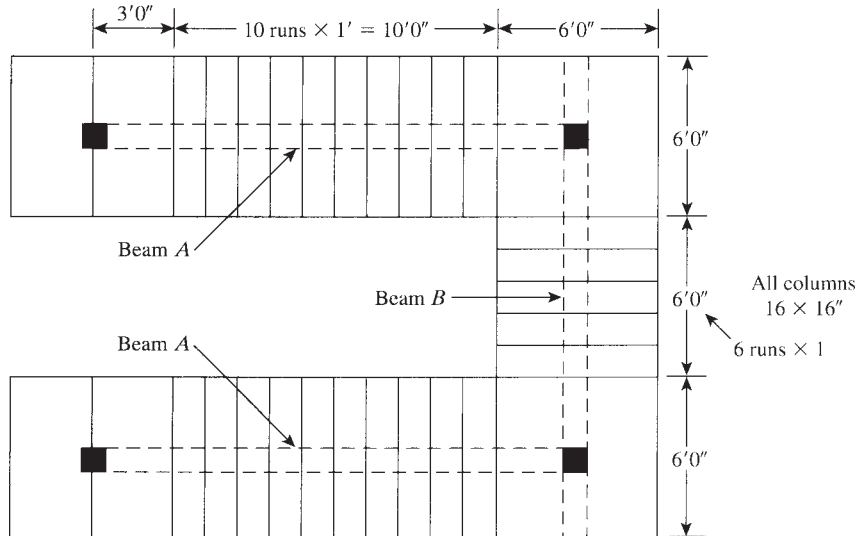


Figure 18.24 Problem 18.4.

*Note:* Design the beams for bending moments and shear, and neglect torsional moments caused by loading one-half of the steps.

- 18.5** Repeat Example 18.3 if the run is 12 in. (300 mm) and the rise is 6 in. (150 mm).
- 18.6** Repeat Example 18.3 if the landing is 5 ft (6 x 10"), runs are 8.33 ft (10 x 10"), risers at 5.5 ft (11 x 6"), and the live load is 120 psf.

# CHAPTER 19

## INTRODUCTION TO PRESTRESSED CONCRETE



Library building, South Dakota State University, Brookings, South Dakota.

### 19.1 PRESTRESSED CONCRETE

#### 19.1.1 Principles of Prestressing

To prestress a structural member is to induce internal, permanent stresses that counteract the tensile stresses in the concrete resulting from external loads; this extends the range of stress that the member can safely withstand. Prestressing force may be applied either before or at the same time as the application of the external loads. Stresses in the structural member must remain, everywhere and for all states of loading, within the limits of stress that the material can sustain indefinitely. The induced stresses, primarily compressive, are usually created by means of high tensile steel tendons, which are tensioned and anchored to the concrete member. Stresses are transferred to the concrete either by the bond along the surface of the tendon or by anchorages at the ends of the tendon.

To explain this discussion, consider a beam made of plain concrete, which has to resist the external gravity load shown in Fig. 19.1. The beam section is chosen with the tensile flexural stress as the critical criterion for design; therefore, an uneconomical section results. This is because concrete is considerably stronger in compression than in tension. The maximum flexural tensile strength of concrete, the modulus of rupture,  $f_r$ , is equal to  $7.5\lambda\sqrt{f'_c}$  (Fig. 19.1).

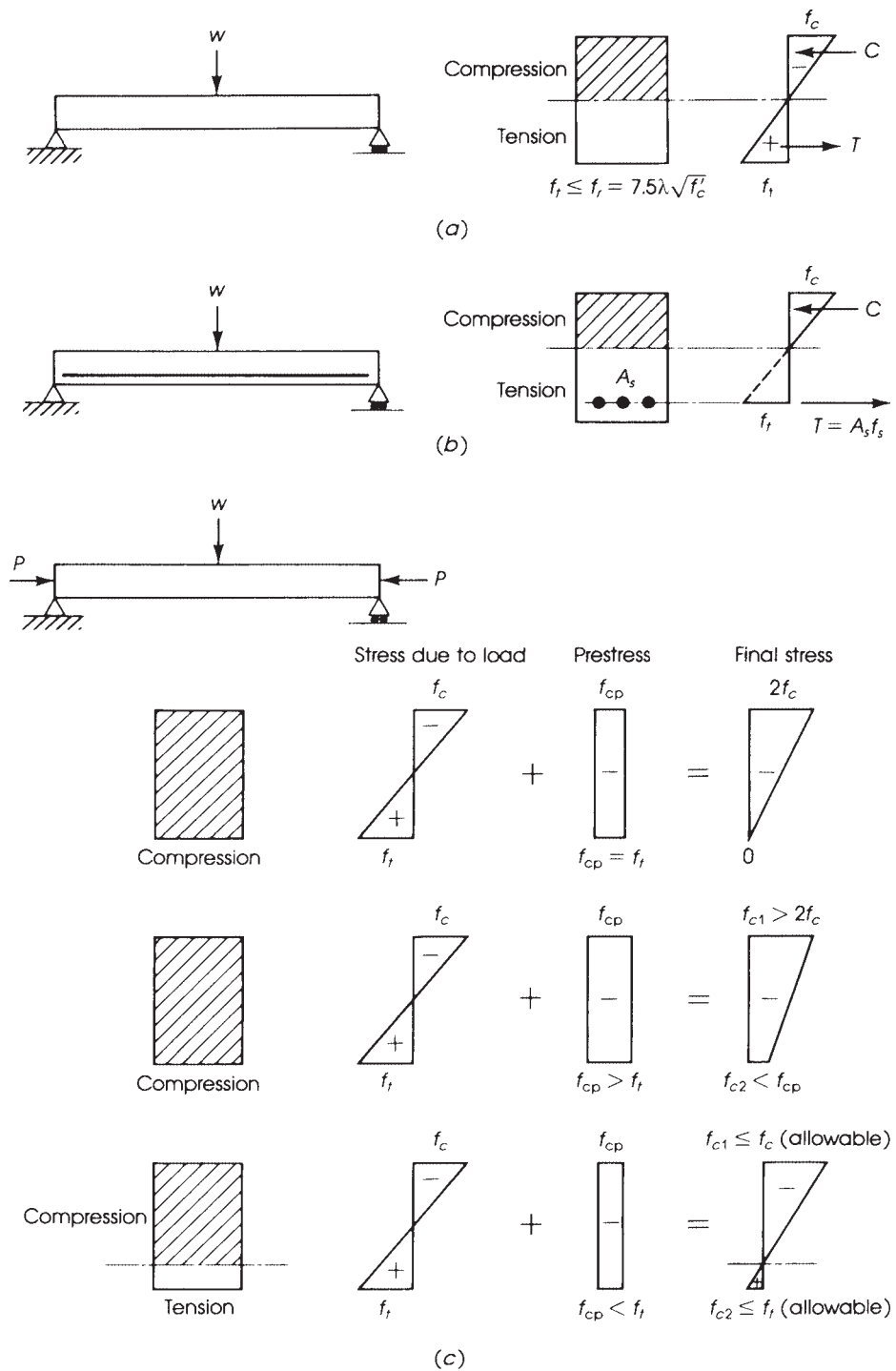
In normal reinforced concrete design, the tensile strength of concrete is ignored and steel bars are placed in the tension zone of the beam to resist the tensile stresses, whereas the concrete resists the compressive stresses (Fig. 19.1).

In prestressed concrete design, an initial compressive stress is introduced to the beam to offset or counteract the tensile stresses produced by the external loads (Fig. 19.1). If the induced compressive stress is equal to the tensile stress at the bottom fibers, then both stresses cancel themselves, whereas the compressive stress in the top fibers is doubled; in this case, the whole section is in compression. If the induced compressive stress is less than the tensile stress at the bottom fibers, these fibers will be in tension, whereas the top fibers are in compression.

In practice, a concrete member may be prestressed in one of the following methods.

1. *Posttensioning*: In posttensioning, the steel tendons are tensioned after the concrete has been cast and hardened. Posttensioning is performed by two main operations: tensioning the steel wires or strands by hydraulic jacks that stretch the strands while bearing against the ends of the member and then replacing the jacks by permanent anchorages that bear on the member and maintain the steel strands in tension. A tendon is generally made of wires, strands, or bars.





**Figure 19.1** Effect of prestressing: (a) plain concrete, (b) reinforced concrete, and (c) prestressed concrete.

Wires and strands can be tensioned in groups, whereas bars are tensioned one at a time. In the posttensioning process, the steel tendons are placed in the formwork before the concrete is cast and the tendons are prevented from bonding to the concrete by waterproof paper wrapping or a metal duct (sheath). Tendons bonded to the concrete are called bonded tendons. Unbonded tendons, left without grout or coated with grease, have no bond throughout the length of the tendon.

2. *Pretensioning*: In pretensioning, the steel tendons are tensioned before the concrete is cast. The tendons are temporarily anchored against some abutments and then cut or released after the concrete has been placed and hardened. The prestressing force is transferred to the concrete by the bond along the length of the tendon. Pretensioning is generally done in precasting plants in permanent beds, which are used to produce pretensioned precast concrete elements for the building industry.
3. *External prestressing*: In external prestressing, the prestressing force is applied by flat jacks placed between the concrete member ends and permanent rigid abutments. The member does not contain prestressing tendons, as in the previous two methods (also called internal prestressing). External prestressing is not easy in practice because shrinkage and creep in concrete tend to reduce the induced compressive stresses unless the prestressing force can be adjusted.

The profile of the tendons may be straight, curved (bent), or circular, depending on the design of the structural member. Straight tendons are generally used in solid and hollow-cored slabs, whereas bent tendons are used in beams and most structural members. Circular tendons are used in circular structures such as tanks, silos, and pipes. The prestressing force may be applied in one or more stages, either to avoid overstressing concrete or in cases when the loads are applied in stages. In this case, part of the tendons are fully prestressed at each stage.

A considerable number of prestressing systems have been devised, among them Freyssinet, Magnel Blaton, B.B.R.V., Dywidag, CCL, Morandi, VSL, Western Concrete, Prescon, and INRYCO. The choice of the prestressing system for a particular job can sometimes be a problem. The engineer should consider three main factors that govern the choice of the system:

1. The magnitude of the prestressing force required.
2. The geometry of the section and the space available for the tendons.
3. Cost of the prestressing system (materials and labor).

The following example illustrates some of the features of prestressed concrete.

### Example 19.1

For the simply supported beam shown in Fig. 19.2, determine the maximum stresses at midspan section due to its own weight and the following cases of loading and prestressing:

1. A uniform live load of 900 lb/ft.
2. A uniform live load of 900 lb/ft and an axial centroidal longitudinal compressive force of  $P = 259.2$  K.
3. A uniform live load of 2100 lb/ft and an eccentric longitudinal compressive force  $P = 259.2$  K acting at an eccentricity  $e = 4$  in.
4. A uniform live load of 2733 lb/ft and an eccentric longitudinal compressive force  $P = 259.2$  K acting at the maximum practical eccentricity for this section ( $e = 6$  in.).
5. The maximum live load when  $P = 259.2$  K acting at  $e = 6$  in.

Use  $b = 12$  in.,  $h = 24$  in., normal-weight concrete with  $f'_c = 4500$  psi, and an allowable  $f'_c = 2050$  psi.

**Solution**

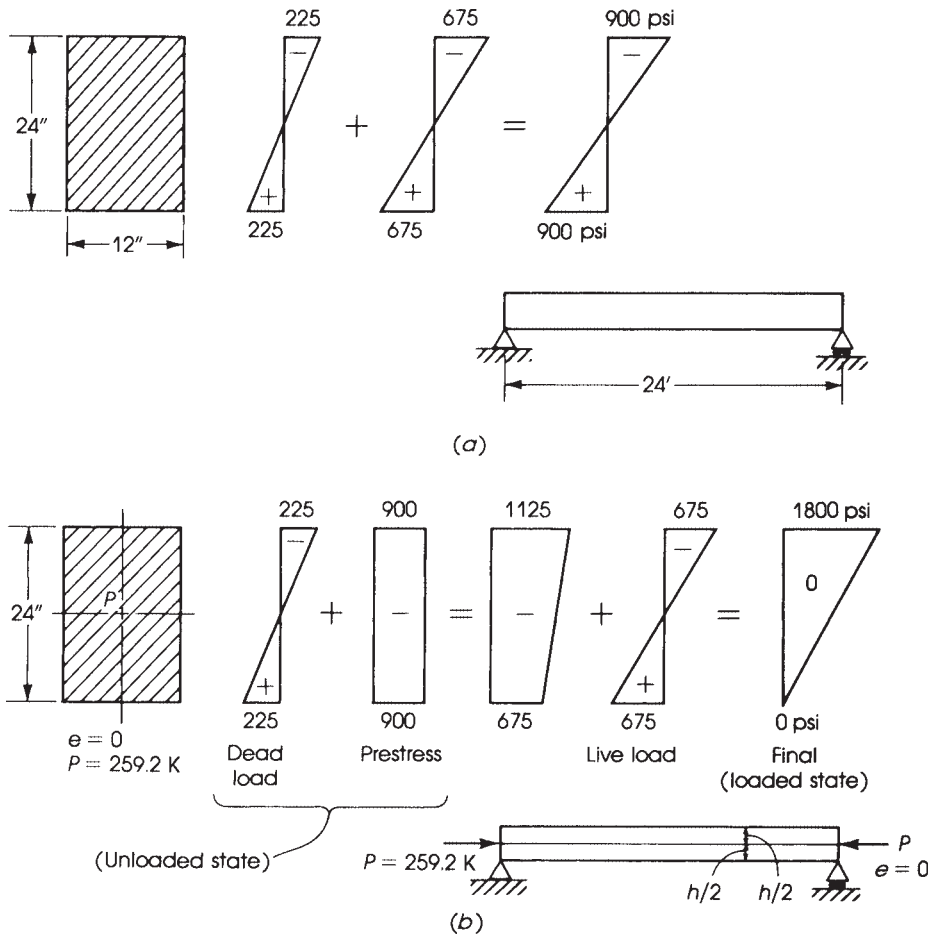
- Stresses due to dead and live loads only are the self-weight of the beam  $= (1 \times 2) \times 150 = 300$  lb/ft:

$$\text{dead - load moment } M_{DL} = \frac{\omega L^2}{8} = \frac{0.300(24)^2}{8} = 21.6 \text{ K} \cdot \text{ft}$$

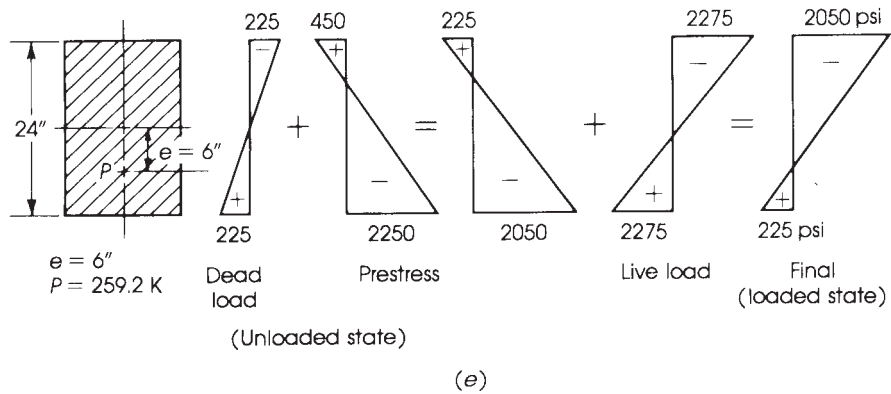
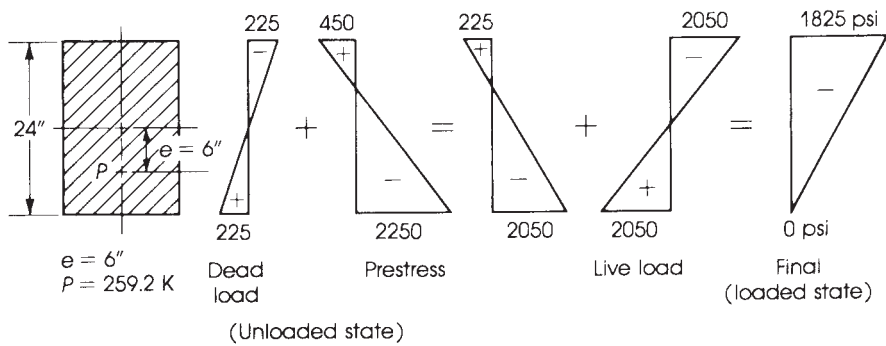
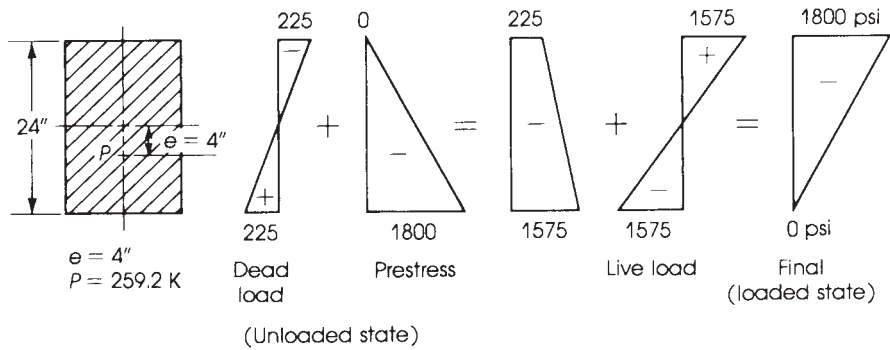
Stresses at the extreme fibers are

$$\sigma = \frac{Mc}{I} = \frac{M(h/2)}{bh^3/12} = \frac{6M}{bh^2}$$

$$\sigma_D = \frac{6 \times 21.6 \times 12,000}{12(24)^2} = \pm 225 \text{ psi}$$



**Figure 19.2** Example 19.1.



**Figure 19.2** (Continued)

Stresses due to the live load  $L_1 = 900 \text{ lb/ft}$  are

$$M_{LL} = \frac{0.9(24)^2}{8} = 64.8 \text{ K} \cdot \text{ft}$$

$$\sigma_{L_1} = \frac{6M}{bh^2} = \frac{6 \times 64.8 \times 12,000}{12(24)^2} = \pm 675 \text{ psi}$$

Adding stresses due to the dead and live loads (Fig. 19.2) gives

$$\begin{aligned}\text{Top stress} &= -225 - 675 = -900 \text{ psi} && \text{(compression)} \\ \text{Bottom stress} &= +225 + 675 = +900 \text{ psi} && \text{(tension)}\end{aligned}$$

The tensile stress is higher than the modulus of rupture of concrete,  $f_r = 7.5\lambda\sqrt{f'_c} = 503$  psi; hence, the beam will collapse.

2. In the case of stresses due to uniform prestress, if a compressive force  $P = 259.2$  K is applied at the centroid of the section, then a uniform stress is induced on any section along the beam:

$$\sigma_P = \frac{P}{\text{area}} = \frac{259.2 \times 1000}{12 \times 24} = -900 \text{ psi} \quad \text{(compression)}$$

Final stresses due to live and dead loads plus prestress load at the top and bottom fibers are 1800 psi and 0, respectively (Fig. 19.2). In this case, the prestressing force has doubled the compressive stress at the top fibers and reduced the tensile stress at the bottom fibers to 0. The maximum compressive stress of 1800 psi is less than the allowable stress of 2050 psi.

3. For stresses due to an eccentric prestress ( $e = 4$  in.), if the prestressing force  $P = 259.2$  K is placed at an eccentricity of  $e = 4$  in. below the centroid of the section, the stresses at the top and bottom fibers are calculated as follows. Moment due to eccentric prestress is  $Pe$ :

$$\begin{aligned}\sigma_P &= -\frac{P}{A} \pm \frac{(Pe)c}{I} = -\frac{P}{A} \pm \frac{6(Pe)}{bh^2} \\ &= -\frac{259.2 \times 1000}{12 \times 24} \pm \frac{6(259.2 \times 1000 \times 4)}{12(24)^2} \\ &= -900 \pm 900 \\ &= -1800 \text{ psi}\end{aligned}$$

at the bottom fibers and  $\sigma_P = 0$  at the top fibers. Consider now an increase in the live load of  $L_2 = 2100$  lb/ft:

$$\begin{aligned}M_{LL} &= \frac{2.1 \times (24)^2}{8} = 151.2 \text{ K} \cdot \text{ft} \\ \sigma_{L_2} &= \frac{6(151.2 \times 12,000)}{12(24)^2} = \pm 1575 \text{ psi}\end{aligned}$$

Final stresses due to the dead, live, and prestressing loads at the top and bottom fibers are 1800 psi and 0, respectively (Fig. 19.2). Note that the final stresses are exactly the same as those of the previous case when the live load was 900 lb/ft; by applying the same prestressing force but at an eccentricity of 4 in., the same beam can now support a greater live load (by 1200 lb/ft).

4. For stresses due to eccentric prestress with maximum eccentricity, assume that the maximum practical eccentricity for this section is at  $e = 6$  in., leaving a 2-in. concrete cover; then the bending moment induced is  $Pe = 259.2 \times 6 = 1555.2$  K·in. = 129.6 K·ft. Stresses due to the prestressing force are

$$\begin{aligned}\sigma_P &= -\frac{259.2 \times 1000}{12 \times 24} \pm \frac{6 \times (129.6 \times 12,000)}{12(24)^2} \\ &= -900 \pm 1350 \text{ psi} \\ &= -2250 \text{ psi} \quad \text{and} \quad +450 \text{ psi}\end{aligned}$$

Increase the live load now to  $L_3 = 2733$  lb/ft. The stresses due to the live load,  $L_3$ , are

$$M_{LL} = \frac{2.733 \times (24)^2}{8} = 196.8 \text{ K} \cdot \text{ft}$$

$$\sigma_{L_3} = \frac{6(196.8 \times 12,000)}{12(24)^2} = \pm 2050 \text{ psi}$$

The final stresses at the top and bottom fibers due to the dead load, live load ( $L_3$ ), and the prestressing force are 1825 psi and 0, respectively (Fig. 19.2). Note that the final stresses are about the same as those in the previous cases, yet the live load has been increased to 2733 lb/ft. A tensile stress of 225 psi is developed when the prestressing force is applied on the beam. This stress is less than the modulus of rupture of concrete,  $f_r = 503$  psi; hence, cracks will not develop in the beam.

5. The maximum live load when the eccentric force  $P$  acts at  $e = 6$  in. is determined as follows. In the previous case, the final compressive stress is equal to 1825 psi, which is less than the allowable stress of 2050 psi. Therefore, the live load may be increased to  $L_4 = 3033$  lb/ft.

$$M_{LL} = \frac{3.033 \times (24)^2}{8}$$

$$\sigma_{L_4} = \frac{6(218.4 \times 12,000)}{12(24)^2} = \pm 2275 \text{ psi}$$

Final stresses due to the dead load, live load ( $L_4$ ), and the prestressing force are  $-2050$  psi and  $\pm 225$  psi (Fig. 19.2). The compressive stress is equal to the allowable stress of 2050 psi, and the tensile stress is less than the modulus of rupture of concrete of 503 psi. In this case, the uniform live load of 3033 lb/ft has been calculated as follows: Add the maximum allowable compressive stress of 2050 psi to the initial tensile stress at the top fibers of 225 psi to get 2275 psi. The moment that will produce a stress at the top fibers of 2275 psi is equal to

$$M = \sigma \left( \frac{bh^2}{6} \right)$$

$$= \frac{2.275}{6} (12)(24)^2 = 2620.8 \text{ K} \cdot \text{in.} = 218.4 \text{ K} \cdot \text{ft}$$

$$M = \frac{W_L L^2}{8} \quad \text{and} \quad W_L = \frac{8 \times 218.4}{(24)^2} = 3.033 \text{ K/ft}$$

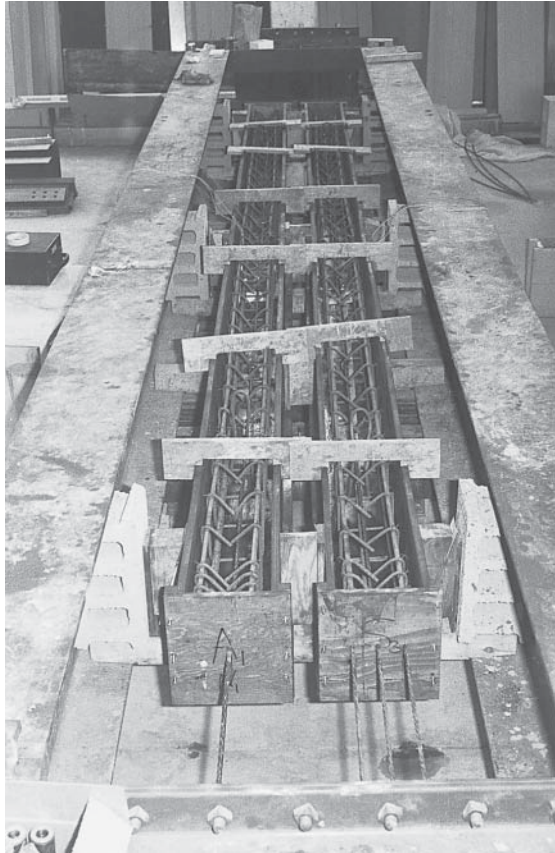
*Notes:*

- a. The entire concrete section is active in resisting the external loads.
- b. The final tensile stress in the section is less than the modulus of rupture of concrete, which indicates that a crackless concrete section can be achieved under full load.
- c. The allowable load on the beam has been increased appreciably due to the application of the prestressing force.
- d. An increase in the eccentricity of the prestressing force will increase the allowable applied load, provided that the allowable stresses on the section are not exceeded.

### 19.1.2 Partial Prestressing

A partially prestressed concrete member can be defined as one in which (1) there have been introduced internal stresses to counteract part of the stresses resulting from external loadings, (2) tensile stresses are developed in the concrete under working loads, and (3) nonprestressed reinforcement

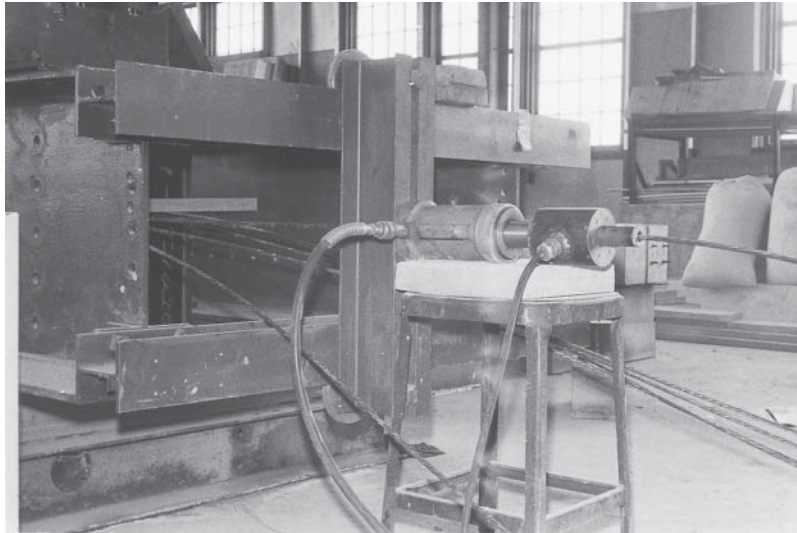
may be added to increase the moment capacity of the member. That definition implies that there are two cases that could be considered as partially prestressed concrete:



Partially prestressed concrete beams.

1. A combination of prestressed and nonprestressed steel is used in the same section. The prestressed cables induce internal stresses designed to take only part of the ultimate capacity of the concrete section. The rest of the capacity is taken by nonprestressed steel placed along the same direction as the prestressed cables. The steel used as nonprestressed steel could be any common grade of carbon steel or high-tensile-strength steel of the same kind as the prestressing cables with an ultimate strength of 250 ksi ( $1725 \text{ N/mm}^2$ ). The choice depends on two main factors: allowable deflection and allowable crack width. As for deflection, the ACI Code specifies a maximum ratio of span to depth of reinforced concrete members. With the smaller depth expected in partially prestressed concrete, and because a smaller steel percentage is used, excessive deflection under working loads must not be allowed. Cracks develop on the tension side of the concrete section or at the steel level because tensile stresses are allowed to occur under working loads. The maximum crack width that may be allowed is 0.016 in. (0.41 mm) for interior members and 0.013 in. (0.33 mm) for exterior members.
2. Internal stresses act on the member from prestressed steel only, but tensioned to a lower limit. In this case cracking develops earlier than in a fully prestressed member under similar loadings.

Partially prestressed concrete can be considered an intermediate form between reinforced and fully prestressed concrete. In reinforced concrete members, cracks develop under working loads; therefore, reinforcement is placed in the tension zone. In prestressed concrete members, cracks do not usually develop under working loads. The compressive stresses due to prestressing may equal or exceed the tensile stresses due to external loadings. Therefore, a partially prestressed concrete member may be considered a reinforced concrete member in which internal stresses are introduced to counteract part of the stress from external loadings so that tensile stresses in the concrete do not exceed a limited value under working load. It reduces to reinforced concrete when no internal stresses act on the member. Full prestressing is an upper extreme of partial prestressing in which nonprestressed reinforcing steel reduces to 0.



Prestressing jack with a load cell.

Between a reinforced cracked member and a fully prestressed uncracked member, there exists a wide range of design in partial prestressing (Fig. 19.3). A proper choice of the degree of prestressing will produce a safe and economical structure.

Figure 19.3 shows the load–deflection curves of concrete beams containing different amounts and types of reinforcement. Curve *a* represents a reinforced concrete beam, which normally cracks at a small load  $W_{cr}$ . The cracking moment  $M_{cr}$  can be determined as follows:

$$M_{cr} = \frac{f_r I}{c}$$

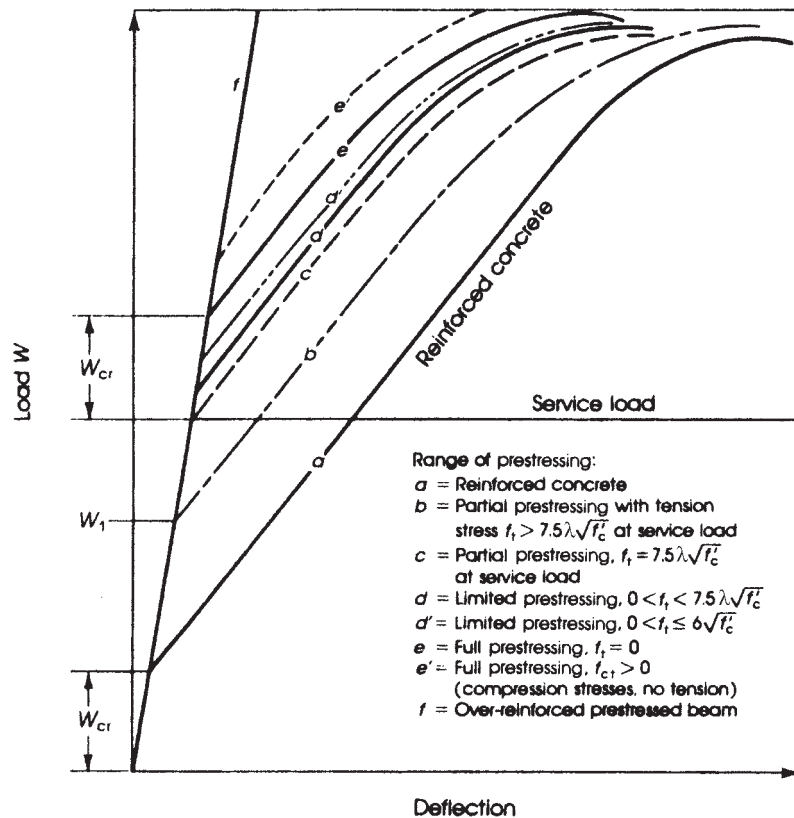
where

- $f_r$  = modulus of rupture of concrete =  $7.5\lambda\sqrt{f'_c}$
- $I$  = moment of inertia of gross concrete section
- $c$  = distance from neutral axis to tensile extreme fibers

The cracking load can be determined from the cracking moment when the span and the type of loading are specified. For a simply supported beam subjected to a concentrated load at midspan,  $W_{cr} = (4M_{cr})/L$ .

Curves *e* and *f* represent underreinforced and overreinforced fully prestressed concrete beams, respectively. The overreinforced concrete beam fails by crushing of the concrete before the steel





**Figure 19.3** Load–deflection curves of concrete beams with different prestressing. The cracking load is  $W_{cr}$ .

reaches its yield strength or proof stress. The beam has small deflection and undergoes brittle failure. The underreinforced beam fails by the steel reaching its yield or ultimate strength. It shows appreciable deflection and cracking due to elongation of the steel before the gradual crushing of the concrete and the collapse of the beam.

Between curves *a* and *e* is a wide range of concrete beams with varying amounts of reinforcement and subjected to varying amounts of prestress. The beam with little prestressing is closer to curve *a*, while the beam with a large prestress is closer to curve *e*. Depending upon the allowable concrete stress, deflection, and maximum crack width, a suitable combination of prestressed and nonprestressed reinforcement may be chosen for the required design.

Curve *b* represents a beam that will crack under full working load. If only part of the live load  $L_1$  occurs frequently on the structure, then  $W_1$  represents the total dead load and that part of the live load  $L_1$ .

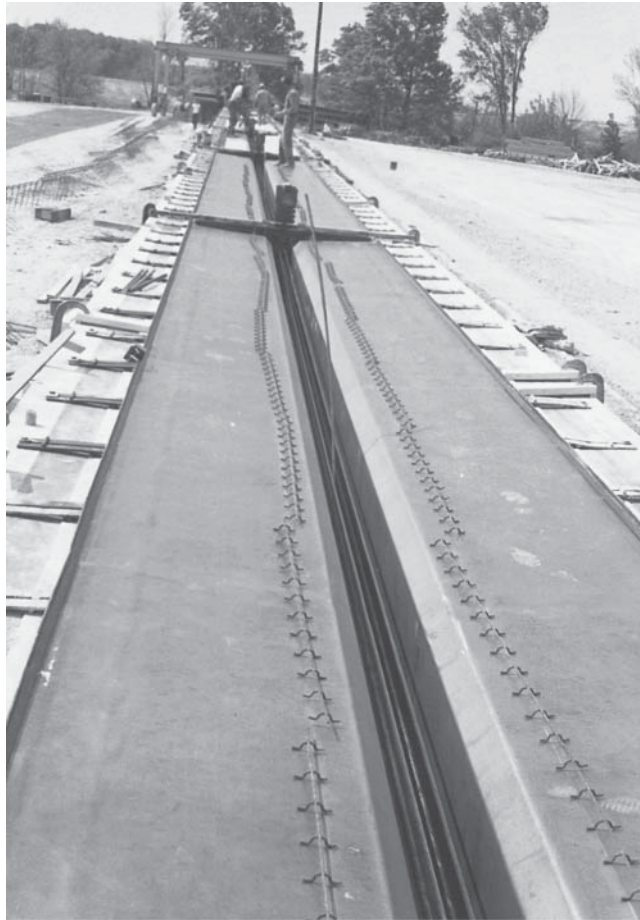
Curve *c* represents a beam that starts cracking at working load. The maximum tensile stress in the concrete  $= 7.5\sqrt{f'_c}$ .

Curve *d* represents a beam with limited prestress. The critical section of the beam will not crack under full working load, but it will have a maximum tensile stress of  $0 < f_t < 7.5\sqrt{f'_c}$ . The maximum tensile stress in concrete allowed by the current ACI Code is  $6\sqrt{f'_c}$ .

Curves *e* and *e'* represent fully prestressed concrete beams with no tensile stress under working loads. (See Fig. 19.4.)

The most important advantage of partial prestressing is the possibility of controlling camber. By reducing the prestressing force, the camber will be reduced and a saving in the amount of the prestressing steel, the amount of work in tensioning, and the number of end anchorages is realized.

Depending on the magnitude of the prestressing force, earlier cracking may occur in partially prestressed rather than in fully prestressed concrete members under service loads. Once cracks develop, the effective moment of inertia of the critical section is reduced and a greater deflection is expected. However, partial prestressing has been used with satisfactory results, and its practical application is increasing.

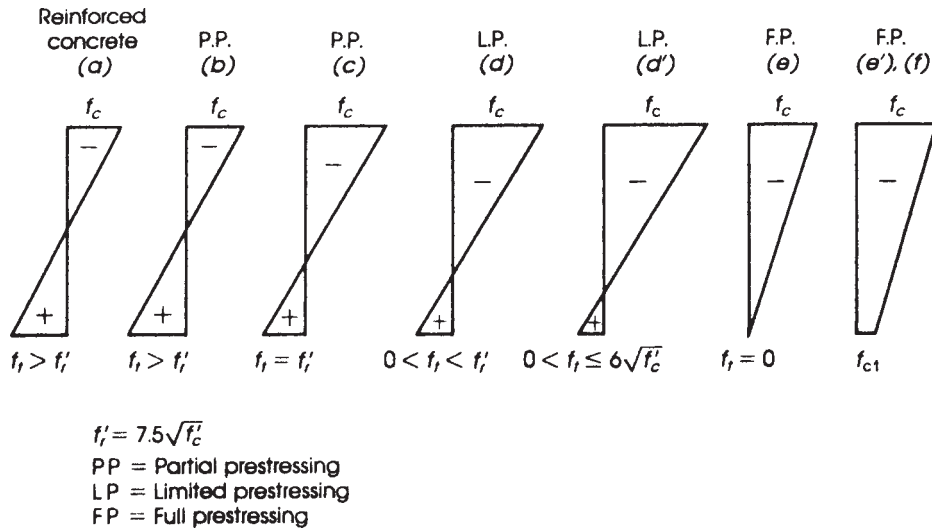


Prestressing bed for T-beam sections.

### 19.1.3 Classification of Prestressed Concrete Flexural Members

The ACI Code, Section 24.5.2, divided prestressed concrete members into three classes based on the computed extreme tensile fiber stress,  $f_t$ , in the tension zone at service load as follows:

1. Class U (uncracked section), with  $f_t \leq 7.5\sqrt{f'_c}$ . In this uncracked concrete section, the gross section properties are used to check deflection at service load. No cracks will develop in this section and no skin reinforcement is needed.



**Figure 19.4** Distribution of stresses in beams with varying amounts of prestressed and nonprestressed reinforcement.

2. Class T (section in the transition zone), with  $7.5\sqrt{f'_c} < f_t \leq 12\sqrt{f'_c}$ . This type of section has a tensile stress in concrete higher than the modulus of rupture of concrete,  $f_r = 7.5\sqrt{f'_c}$ , producing a case between uncracked and cracked sections. In this case, the gross section properties are used to check stresses, while the cracked section bilinear section is used to calculate deflection. No skin reinforcement is needed in the tension zone.
3. Class C (cracked section), with  $f_t > 12\sqrt{f'_c}$ . The tensile stress in the section exceeds 1.6 times the modulus of rupture. Therefore, cracks will develop as in the case of partially prestressed concrete members. In this case a cracked section properties should be used to check stresses, cracking, and deflection. Crack control provisions and skin reinforcement should be used as explained in Section 6.7 for reinforced concrete members with the effective depth of  $d > 36$  in.

## 19.2 MATERIALS AND SERVICEABILITY REQUIREMENTS

### 19.2.1 Concrete

The physical properties of concrete were discussed in Chapter 2. Although reinforced concrete members are frequently made of concrete with a compressive strength of 3 to 5 ksi (21 to 35 MPa), prestressed concrete members are made of higher strength material, usually from 4 to 8 ksi (28 to 56 MPa). High-strength concrete may be adopted for precast, prestressed concrete members where components are prepared under optimum control of mixing concrete, placing, vibrating, and curing.

The allowable stresses in concrete according to the ACI Code, Section 24.5.3, are as follows.

1. Stresses after prestress transfer and before prestress losses:
  - a. Maximum compressive stress of  $0.6f'_{ci}$
  - b. Maximum compressive stress at ends of simply supported  $0.7f'_{ci}$

- c. Maximum tensile stress (experts as permitted below in d) of  $3\sqrt{f'_{ci}}$
- d. Maximum tensile stress at the ends of simply supported members of  $6\sqrt{f'_{ci}}$  where  $f'_{ci}$  is the strength of concrete at transfer

If the maximum tensile stresses are exceeded in c or d, then reinforcement must be provided in the tensile zone to resist the total tensile force in concrete (based on uncracked gross section).

2. Stresses at service loads after all losses (for class U and class T) are as follows: Maximum compressive stress of  $0.45f'_c$  due to prestresses plus sustained loads and of  $0.6\sqrt{f'_c}$  due to prestress plus total load.
3. These stresses may be exceeded if it is shown by tests or analysis that performance is satisfactory.

### 19.2.2 Prestressing Steel

The most common type of steel tendons used in prestressed concrete are strands (or cables) made with several wires, usually 7 or 19. Wires and bars are also used. The strands and wires are manufactured according to ASTM Standard A421 for uncoated stress-relieved wires and A416 for uncoated 7-wire stress-relieved strands. Properties of prestressing steel are given in Table 19.1.



Seven-wires prestressing strands (shipped in coils as shown).

Prestressing steel used in prestressed concrete must be of high-strength quality, usually of ultimate strength,  $f_{pu}$ , of 250 to 270 ksi (1730 to 1860 MPa). High-strength steel is necessary to permit high elongation and to maintain a permanent sufficient prestress in the concrete after the inelastic shortening of the concrete.

The allowable stresses in prestressing steel according to the ACI Code, Section 20.3.2.5, are as follows:

1. Maximum stress due to tendon jacking force must not exceed the smaller of  $0.8f_{pu}$  or  $0.94f_{py}$ . (The smaller value must not exceed that stress recommended by the manufacturer of tendons or anchorages.)
2. Maximum stress in pretensioned tendons immediately after transfer must not exceed the smaller of  $0.74f_{pu}$  or  $0.82f_{py}$ .
3. Maximum stress in posttensioning tendons after tendon is anchored is  $0.70f_{pu}$ .

**Table 19.1** Properties of Prestressing Steel, Nominal Diameters, Areas, and Weights

Type	Diameter (in.)	Area (in. <sup>2</sup> )	Weight (lb/ft)	Diameter (mm)	Area (mm <sup>2</sup> )	Mass (kg/m)
Seven-wire strand (grade 250)	$\frac{1}{4}$ (0.250)	0.036	0.12	6.350	23.2	0.179
	$\frac{5}{16}$ (0.313)	0.058	0.20	7.950	37.4	0.298
	$\frac{3}{8}$ (0.375)	0.080	0.27	9.525	51.6	0.402
	$\frac{7}{16}$ (0.438)	0.108	0.37	11.125	69.7	0.551
	$\frac{1}{2}$ (0.500)	0.144	0.49	12.700	92.9	0.729
Seven-wire strand (grade 270)	$\frac{1}{2}$ (0.600)	0.216	0.74	15.240	139.4	1.101
	$\frac{3}{8}$ (0.375)	0.085	0.29	9.525	54.8	0.432
	$\frac{7}{16}$ (0.438)	0.115	0.40	11.125	74.2	0.595
	$\frac{1}{2}$ (0.500)	0.153	0.53	12.700	98.7	0.789
Prestressing wire grades (250)	(250)	0.192	0.10	4.877	18.7	0.146
	(250)	0.196	0.10	4.978	19.4	0.149
	(240)	0.250	0.17	6.350	31.6	0.253
	(235)	0.276	0.20	7.010	38.7	0.298
Prestressing bars (smooth) (grade 145 or 160)	$\frac{3}{4}$ (0.750)	0.44	1.50	19.050	283.9	2.232
	$\frac{7}{8}$ (0.875)	0.60	2.04	22.225	387.1	3.036
	1 (1.000)	0.78	2.67	25.400	503.2	3.973
	$1\frac{1}{8}$ (1.125)	0.99	3.38	28.575	638.7	5.030
	$1\frac{1}{4}$ (1.250)	1.23	4.17	31.750	793.5	6.206
	$1\frac{3}{8}$ (1.385)	1.48	5.05	34.925	954.8	7.515
	$1\frac{5}{8}$ (1.625)	1.88	6.80	44.100	1240.0	9.430
Prestressing bars (deformed) (grades 150–160)	$\frac{5}{8}$ (0.625)	0.28	0.98	15.875	180.6	1.458
	$\frac{3}{4}$ (0.750)	0.42	1.49	19.050	271.0	2.218
	1 (1.000)	0.85	3.01	25.400	548.4	4.480
	$1\frac{1}{4}$ (1.250)	1.25	4.39	31.750	806.5	6.535
	$1\frac{3}{8}$ (1.385)	1.58	5.56	34.925	1006	8.274

### 19.2.3 Reinforcing Steel

Nonprestressed reinforcing steel is commonly used in prestressed concrete structural members, mainly in the prestressed, precast concrete construction. The reinforcing steel is used as shear reinforcement, as supplementary reinforcement for transporting and handling the precast elements, and in combination with the prestressing steel in partially prestressed concrete members. The types and allowable stresses of reinforcing bars were discussed in Chapters 2 and 5.

## 19.3 LOSS OF PRESTRESS

### 19.3.1 Lump-Sum Losses

Following the transfer of the prestressing force from the jack to the concrete member, a continuous loss in the prestressing force occurs; the total loss of prestress is the reduction in the prestressing

force during the life span of the structure. The amount of loss in tendon stress varies between 15 and 30% of the initial stress because it depends on many factors. For most normal-weight concrete structures constructed by standard methods, the tendon stress loss due to elastic shortening, shrinkage, creep, and relaxation of steel is about 35 ksi (241 MPa) for pretensioned members and 25 ksi (172 MPa) for posttensioned members. Friction and anchorage slip are not included.

Two current recommendations for estimating the total loss in prestressed concrete members are presented by AASHTO and the Posttensioning Institute (PTI). AASHTO [23] recommends a total loss (excluding friction loss) of 45 ksi (310 MPa) for pretensioned strands and 33 ksi (228 MPa) for posttensioned strands and wires when a concrete strength of  $f'_c = 5$  ksi is used. The PTI [24] recommends a total lump-sum prestress loss for posttensioned members of 35 ksi (241 MPa) for beams and 30 ksi (207 MPa) for slabs (excluding friction loss). These values can be used unless a better estimate of the prestress loss by each individual source is made, as is explained shortly.

In general, the sources of prestress loss are

- Elastic shortening of concrete
- Shrinkage of concrete
- Creep of concrete
- Relaxation of steel tendons
- Friction
- Anchorage set

### 19.3.2 Loss due to Elastic Shortening of Concrete

In pretensioned members, estimating loss proceeds as follows. Consider a pretensioned concrete member of constant section and stressed uniformly along its centroidal axis by a force  $F_0$ . After the transfer of the prestressing force, the concrete beam and the prestressing tendon shorten by an equal amount because of the bond between the two materials. Consequently, the starting prestressing force  $F_0$  drops to  $F_i$  and the loss in the prestressing force is  $F_0 - F_i$ . Also, the strain in the concrete,  $\epsilon_c$ , must be equal to the change in the tendon strain,  $\Delta\epsilon_s$ . Therefore,  $\epsilon_c = \Delta\epsilon_s$ , or  $f_c/E_c = \Delta f_s/E_s$ , and the stress loss due to the elastic shortening is

$$\Delta f_s = \frac{E_s}{E_c} \times f_c = n f_c = \frac{n F_i}{A_c} \approx \frac{n F_0}{A_c} \quad (19.1)$$

where

$A_c$  = area of concrete section

$n = E_s/E_c$  = modular ratio

$f_c$  = stress in concrete at centroid of prestressing steel

Multiply the stress by the area of the prestressing steel,  $A_{sp}$ , to get the total force; then the elastic loss is

$$ES = F_0 - F_i = \Delta f_s A_{sp} = (n f_c) A_{sp} \approx \left( \frac{n F_0}{A_c} \right) A_{sp} \quad (19.2)$$

$$F_i = F_0 - (n f_c) A_{sp} \quad (19.3)$$

For practical design, the loss in the prestressing force,  $\Delta f_s$  per unit  $A_{sp}$ , may be taken to be approximately  $n F_0/A_c$ . If the force  $F_0$  acts at an eccentricity  $e$ , then the elastic loss due to the presence of  $F_0$  and the applied dead load at transfer is

$$ES = -(n f_c) A_{sp} \text{ (due to prestress)} + (n f_c) A_{sp} \text{ (dead load)}$$

and

$$ES = F_0 - F_i = - \left( \frac{F_i}{A} + \frac{F_i e^2}{I} \right) n A_{sp} + \left( \frac{M_D e}{I} \right) n A_{sp} \quad (19.4)$$

An approximate value of  $F_i = (0.63 f_{pu}) A_{sp}$  may be used in the above equation:

$$F_0 + f_c (\text{DL}) n A_{sp} = F_i \left[ 1 + n A_{sp} \left( \frac{1}{A} + \frac{e^2}{I} \right) \right]$$

$$F_i = \frac{F_0 + (n A_{sp}) f_c (\text{DL})}{1 + (n A_{sp}) (1A + e^2 I)} \quad (19.5)$$

For posttensioned members where the tendons or individual strands are not stressed simultaneously, the loss of the prestress can be taken as half the value ES for pretensioned members.

Also, it is practical to consider the elastic shortening loss in slabs equal to one-quarter of the equivalent pretensioned value because stretching of one tendon will have little effect on the stressing of the other tendons.

### 19.3.3 Loss due to Shrinkage

The loss of prestress due to shrinkage is time dependent. It may be estimated as follows:

$$SH = \Delta f_s (\text{shrinkage}) = \epsilon_{sh} E_s \quad (19.6)$$

where  $E_s$  is  $29 \times 10^6$  psi and  $\epsilon_{sh}$  is the shrinkage strain in concrete.

The average strain due to shrinkage may be assumed to have the following values: for pretensioned members,  $\epsilon_{sh_1} = 0.0003$ ; for posttensioned members,  $\epsilon_{sh_2} = 0.0002$ . If posttensioning is carried out within 5 to 7 days after concreting, the shrinkage strain can be taken to be  $0.8 \epsilon_{sh_1}$ . If posttensioning is carried out between 1 and 2 weeks,  $\epsilon_{sh} = 0.7 \epsilon_{sh_1}$  can be used, and if it occurs more than 2 weeks later,  $\epsilon_{sh} = \epsilon_{sh_2}$  can be adopted. Shrinkage loss, SH, can also be estimated as follows [28]:

$$SH = 8.2 \times 10^{-6} K_{sh} E_s \left( 1 - \frac{0.06V}{S} \right) (100 - \text{RH})$$

where  $V/S$  is the volume-to-surface ratio and RH is the average relative humidity;  $K_{sh}$  is 1.0 for pretensioned members and 0.8, 0.73, 0.64, and 0.58 for posttensioned members if posttensioning is carried out after 5, 10, 20, and 30 days, respectively.

### 19.3.4 Loss Due to Creep of Concrete

Creep is a time-dependent deformation that occurs in concrete under sustained loads. The developed deformation causes a loss of prestress from 5 to 7% of the applied force.

The creep strain varies with the magnitude of the initial stress in the concrete, the relative humidity, and time. The loss in stress due to creep can be expressed as follows:

$$\text{CR} = \Delta f_s (\text{creep}) = C_c (n f_c) = C_c (\epsilon_{cr} E_s) \quad (19.7)$$

where

$$C_c = \text{creep coefficient} = \frac{\text{creep strain, } \epsilon_{cp}}{\text{initial elastic strain, } \epsilon_i}$$

The value of  $C_c$  may be taken as follows:

Concrete strength	$f'_c \leq 4$ ksi		$f'_c > 4$ ksi	
Relative humidity	%	50%	100%	50%
$C_c$	1–2	2–4	0.7–1.5	1.5–3

Linear interpolation can be made between these values. Considering that half the creep takes place in the first 134 days of the first 6 months after transfer and under normal humidity conditions, the creep strain can be assumed for practical design as follows:

1. For pretensioned members,  $\epsilon_{cr} = 48 \times 10^{-5}$  stress in concrete (ksi).
2. For posttensioned members,  $\epsilon_{cr} = 36 \times 10^{-5} \times$  stress in concrete (ksi). This value is used when posttensioning is made within 2 to 3 weeks. For earlier posttensioning, an intermediate value may be used.

These values apply when the strength of concrete at transfer is  $f'_{ci} \geq 4$  ksi. When  $f'_{ci} < 4$  ksi, the creep strain should increase in the ratio of (4/actual strength).

$$\text{Total loss of prestress due to creep} = \epsilon_{cr} E_s \quad (19.8)$$

### 19.3.5 Loss Due to Relaxation of Steel

Relaxation of steel causes a time-dependent loss in the initial prestressing force, similar to creep in concrete. The loss due to relaxation varies for different types of steel; its magnitude is usually furnished by the steel manufacturers. The loss is generally assumed to be 3% of the initial steel stress for posttensioned members and 2 to 3% for pretensioned members. If test information is not available, the loss percentages for relaxation at 1000 h can be assumed as follows:

1. In low-relaxation strands, when the initial prestress is  $0.7 f_{pu}$  and  $0.8 f_{pu}$ , relaxation (RE) is 2.5 and 3.5%, respectively.
2. In stress-relieved strands or wire, when the initial prestress is  $0.7 f_{pu}$  or  $0.8 f_{pu}$ , relaxation (RE) is 8 and 12%, respectively.

### 19.3.6 Loss Due to Friction

With pretensioned steel, friction loss occurs when wires or strands are deflected through a diaphragm. This loss is usually small and can be neglected. When the strands are deflected to follow a concordant profile, the friction loss may be considerable. In such cases, accurate load measuring devices are commonly used to determine the force in the tendon.

With posttensioned steel, the effect of friction is considerable because of two main factors: the curvature of the tendon and the lack of alignment (wobble) of the duct. The curvature effect may be visualized if a belt around a fixed cylinder is tensioned on one end with a force  $P_2$ ; then the force,  $P_1$ , at the other end to initiate slippage in the direction of  $P_1$  is

$$P_1 = P_2 e^{\mu \alpha_{px}} \quad (19.9)$$

where  $\mu$  is the coefficient of static angular friction and  $\alpha_{px}$  is the angle between  $P_1$  and  $P_2$ . It is a general practice to treat the wobbling effect similarly:

$$P_x = P_s e^{-(\mu \alpha + K l_x)}$$

$$P_{px} = P_{pi} e^{-(K l_{px} + \mu_p \alpha_{px})} \quad (\text{ACI 2008 Code Eq. 18.1}) \quad (19.10)$$



where

$P_{pj}$  = prestressing tendon force at jacking end

$P_{px}$  = prestressing tendon force at any point  $x$

$\mu_p$  = curvature friction coefficient

$\alpha_{px}$  = total angular change of prestressing tendon profile, in radians, from tendon jacking end to any point  $x$

$$= \frac{\text{length of curve}}{\text{radius of curvature}}$$

$K$  = wobble friction coefficient per foot of prestressing tendon

As an approximation, the ACI Code gives the following expression:

$$P_{px} = P_{pj}(1 + Kl_{px} + \mu_p\alpha_{px})^{-1} \quad (\text{ACI Code 2008, Eq. 18.2}) \quad (19.11)$$

provided that  $(Kl_{px} + \mu_p\alpha_{px}) \leq 0.30$ .

The frictional coefficients  $\alpha$  and  $K$  depend on the type of prestressing strands or wires, type of duct, and the surface conditions. Some approximate values for  $\mu$  and  $K$  are given in Table 19.2.

Friction loss in the jack is variable and depends on many factors, including the length of travel of the arm over a given load range. The use of accurate load cells to measure directly the force in the tendon is recommended. The use of pressure gauges may lead to inaccuracies unless they are calibrated against a known force in the tendon.

The friction loss in the anchorage is dependent mainly upon the type of anchorage and the amount of deviation of the tendon as it passes through the anchorage. This loss is usually small and may be neglected. Guidance in particular cases should be obtained from the manufacturers.

### 19.3.7 Loss Due to Anchor Set

When the force in a tendon is transferred from the jack to the anchorage unit, a small inward movement of the tendon takes place due to the seating of the gripping device or wedges. The slippage causes a shortening of the tendon, which results in a loss in the prestressing force. The magnitude of slippage varies between 0.1 and 0.25 in. (2.5 and 6 mm) and is usually specified by the manufacturer. The loss due to the anchor set may be calculated as follows:

$$\Delta f_s = \Delta \epsilon E_s = \frac{\Delta L}{L} \times E_s \quad (19.12)$$

**Table 19.2** Friction Coefficients for Posttensioned Tendons

Type of Tendon	Wobble Coefficient $K$ per Foot ( $\times 10^{-3}$ )	Curvature Coefficient $\mu$ (per Radian)
Tendon in flexible metal sheathing (grouted)		
Wire tendons	1.0–1.5	0.15–0.25
Seven-wire strand	0.5–2.0	0.15–0.25
High-strength bars	0.1–0.6	0.08–0.30
Pregreased unbonded tendon		
Wire tendons and seven-wire strand	0.3–2.0	0.05–0.15
Mastic-coated unbonded tendons		
Wire tendons and seven-wire strand	1.0–2.0	0.05–0.15

where

$\Delta\epsilon$  = magnitude of anchor slippage

$E_s = 29 \times 10^6$  psi

$L$  = length of tendon

Because the loss in stress is inversely proportional to the length of the tendon (or approximately half the length of the tendon if it is stressed from both ends simultaneously), the percentage loss in steel stress decreases as the length of the tendon increases. If the tendon is elongated by  $\Delta\epsilon$  at transfer, the loss in prestress due to slippage is neglected.

### Example 19.2

A 36-ft-span pretensioned simply supported beam has a rectangular cross section with  $b = 18$  in. and  $h = 32$  in. Calculate the elastic loss and all time-dependent losses. Given: prestressing force at transfer is  $F_i = 435$  K, area of prestressing steel is  $A_{ps} = 3.0$  in.<sup>2</sup>,  $f'_c = 5$  ksi,  $E_c = 5000$  ksi,  $E_s = 29,000$  ksi, profile of tendon is parabolic, eccentricity at midspan = 6.0 in., and eccentricity at ends = 0.

### Solution

1. Elastic shortening: Stress due to the prestressing force at transfer is

$$\frac{F_i}{A_{ps}} = \frac{435}{3} = 145 \text{ ksi}$$

$$\text{Strain in prestressing steel} = \frac{f_s}{E_s} = \frac{145}{29,000} = 0.005$$

Using Eq. Eq. 19.1,

$$n = \frac{E_s}{E_c} = \frac{29,000}{5000} = 5.8 \quad \text{or} \quad 6$$

$$\Delta f_s = \frac{nF_i}{A_c} = \frac{6 \times 435}{32 \times 18} = 4.5 \text{ ksi}$$

Considering the variation in the eccentricity along the beam,

$$\text{Strain at end of section} = \frac{F_i}{A_c E_c} = \frac{435}{(18 \times 32) \times 5000} = 0.151 \times 10^{-3}$$

$$\text{Strain at midspan} = \frac{F_i}{A_c E_c} + \frac{F_i e^2}{I E_c}$$

$$I = \frac{bh^3}{12} = \frac{18(32)^3}{12} = 49,152 \text{ in.}^4$$

$$\text{Strain} = 0.151 \times 10^{-3} + \frac{435(6)^2}{49,152(5000)} = 0.215 \times 10^{-3}$$

$$\text{Average strain} = \frac{1}{2}(0.151 + 0.215) \times 10^{-3} = 0.183 \times 10^{-3}$$

$$\text{Prestress loss} = \text{strain} \times E_s = 0.183 \times 10^{-3} \times 29,000 = 5.3 \text{ ksi}$$

$$\text{Percent loss} = \frac{5.3}{145} = 3.66\%$$

2. Loss due to shrinkage:

$$\text{Shrinkage strain} = 0.0003$$

$$\Delta f_s = \epsilon_{\text{sh}} E_s = 0.0003 \times 29,000 = 8.7 \text{ ksi}$$

$$\text{Percent loss} = \frac{8.7}{145} = 6\%$$

3. Loss due to creep of concrete: Assuming  $C_c = 2.0$ , then  $\Delta f_s = C_c(\epsilon_{\text{cr}} E_s)$ :

$$\text{Elastic strain} = \frac{F_i}{A_c E_c} = 0.151 \times 10^{-3}$$

$$\Delta f_s = 2(0.151 \times 10^{-3} \times 29,000) = 8.8 \text{ ksi}$$

$$\text{Percent loss} = \frac{8.8}{145} = 6.1\%$$

Or, approximately,  $\epsilon_{\text{cr}} = 48 \times 10^{-5} \times \text{stress in the concrete (ksi)}$ :

$$\epsilon_{\text{cr}} = 48 \times 10^{-5} \left( \frac{435}{32 \times 18} \right) = 36 \times 10^{-5}$$

$$\Delta f_s = \epsilon_{\text{cr}} E_s = 36 \times 10^{-5} \times 29,000 = 10.4 \text{ ksi}$$

$$\text{Percent loss} = \frac{10.4}{145} = 7.2\%$$

This is a conservative value, and the same ratio is obtained if  $C_c = 2.38$  is adopted in the preceding calculations.

4. Loss due to relaxation of steel: For low-relaxation strands, the loss is assumed to be 2.5%.

$$\Delta f_s = 0.025 \times 145 = 3.6 \text{ ksi}$$

5. Assume the losses due to bending, friction of cable spacers, and the end block of the pretensioning system are 2%.

$$\Delta f_s = 0.02 \times 145 = 2.9 \text{ ksi}$$

6. Loss due to friction in tendon is 0.

7. Total losses are as follows:

Elastic shortening loss	5.3 ksi	3.6%
Shrinkage loss	8.7 ksi	6.0%
Creep of concrete loss	8.8 ksi	6.1%
Relaxation of steel loss	3.6 ksi	2.5%
Other losses	<u>2.9 ksi</u>	<u>2.0%</u>
Total losses	29.3 ksi	20.2%

$$\text{Effective prestress} = 145 - 24 = 121 \text{ ksi}$$

$$\text{Effective prestressing force } F = 121 \times 3 \text{ in.}^2 = 363 \text{ ksi}$$

$$F = (1 - 0.166)F_i = 0.834F_i$$

$$\text{For } F = \eta F_i, \eta = 0.834.$$

**Example 19.3**

Calculate all losses of a 120-ft-span posttensioned beam that has an I-section with the following details. Area of concrete section ( $A_c$ ) = 760 in.<sup>2</sup>; moment of inertia ( $I_g$ ) =  $1.64 \times 10^5$  in.<sup>4</sup>; prestressing force at transfer ( $F_i$ ) = 1110 K; area of prestressing steel ( $A_{ps}$ ) = 7.5 in.<sup>2</sup>;  $f'_c = 5$  ksi,  $E_c = 5000$  ksi and  $E_s = 29,000$  ksi; profile of tendon is parabolic; eccentricity at midspan = 20 in; and eccentricity at ends = 0.

**Solution**

1. Loss due to elastic shortening:

$$\text{Steel stress at transfer} = \frac{F_i}{A_{ps}} = \frac{1110}{7.5} = 148 \text{ ksi}$$

$$\text{Stress in concrete at end section} = \frac{1110}{760} = 1.46 \text{ ksi}$$

$$\text{Stress in concrete at midspan} = \frac{F_i}{A_c} + \frac{F_i e^2}{I} - \frac{M_D e}{I}$$

$$\text{Weight of beam} = \frac{760}{144} \times 150 = 790 \text{ lb/ft}$$

$$M_D = 0.79 \frac{(120)^2}{8} = 1422 \text{ K} \cdot \text{ft}$$

$$\begin{aligned} \text{Stress at midspan} &= \frac{1110}{760} + \frac{1110(20)^2}{164,000} - \frac{(1422 \times 12)(20)}{164,000} \\ &= 1.46 + 2.71 - 2.08 = 2.09 \text{ ksi} \end{aligned}$$

$$\text{Average stress} = \frac{1.46 + 2.09}{2} = 1.78 \text{ ksi}$$

$$\text{Average strain} = \frac{1.78}{E_c} = \frac{1.78}{5000} = 0.356 \times 10^{-3}$$

Elastic loss is  $\Delta f_s = \epsilon_c E_s = 0.356 \times 103 \times 29,000 = 10.3$  ksi, assuming that the tendons are tensioned two at a time. The first pair will have the greatest loss, whereas the last pair will have 0 loss. Therefore, average  $\Delta f_s = 10.3/2 = 5.15$  ksi.

$$\text{Percent loss} = \frac{5.15}{148} = 3.5\%$$

2. Loss due to shrinkage of concrete:

$$\Delta f_s \text{ (shrinkage)} = 0.0002 E_s = 0.0002 \times 29,000 = 5.8 \text{ ksi}$$

$$\text{Percent loss} = \frac{5.8}{148} = 3.9\%$$

3. Loss due to creep of concrete: Assume  $C_c = 1.5$ .

$$\text{Elastic strain} = \frac{F_i}{A_c E_c} = \frac{1110}{760 \times 5000} = 0.92 \times 10^{-3}$$

$$\begin{aligned} \Delta f_s \text{ (creep)} &= C_c (\epsilon_{cr} E_s) \\ &= 1.5 (0.292 \times 10^{-3} \times 29,000) = 12.7 \text{ ksi} \end{aligned}$$

$$\text{Percent loss} = \frac{12.7}{148} = 8.6\%$$

4. Loss due to relaxation of steel: For low-relaxation strands, the loss is 2.5%.

$$\Delta f_s = 0.025 \times 148 = 3.7 \text{ ksi}$$

5. Slip in anchorage: For tensioning from one end only, assume a slippage of 0.15 in. The length of the cable is  $120 \times 12 = 1440$  in.

$$\Delta f_s = \frac{\Delta L}{L} \times E_s = \frac{0.15}{1440} \times 29,000 = 3 \text{ ksi} \quad (\text{Eq. 19.12})$$

To allow for anchorage slip, set the tensioned force to  $148 + 3 = 151$  ksi on the pressure gauge to leave a net stress of 148 ksi in the tendons.

6. Loss due to friction: The equation of parabolic profile is

$$e_x = \frac{4e}{L^2}(Lx - x^2)$$

where  $e_x$  is the eccentricity at a distance  $x$  measured from the support and  $e$  is eccentricity at midspan:

$$\frac{d(e_x)}{dx} = \frac{4e}{L^2}(L - 2x)$$

is the slope of the tendon at any point. At the support,  $x = 0$  and the slope

$$\frac{d(e_x)}{dx} = \frac{4e}{L} = \frac{4 \times 20}{120 \times 12} = 0.056$$

The slope at midspan is 0; therefore,  $\alpha_{px} = 0.056$ . Using flexible metallic sheath,  $\mu_p = 0.5$  and  $K = 0.001$ . At midspan,  $x = 60$  ft. Check if  $(\mu_p \alpha_{px} + Kl_x) \leq 0.30$ :

$$\mu_p \alpha_{px} + Kl_x = 0.5 \times 0.056 + 0.001 \times 60 = 0.0088 < 0.3$$

$$\begin{aligned} P_{px} &= P_{pj}(1 + Kl_{px} + \mu_p \alpha_{px}) \\ &= P_x(1 + 0.088) = 1.088P_x \\ &= 1.088 \times 148 = 161 \text{ K} \quad (\text{force at jacking end}) \end{aligned}$$

$$\Delta f_s = 161 - 148 = 13 \text{ ksi}$$

$$\text{Percent loss} = \frac{13}{148} = 8.8\% \quad (\text{Eq. 19.11})$$

7. Total losses:

Elastic shortening loss	5.2 ksi	3.5%
Shrinkage loss	5.8 ksi	3.9%
Creep of concrete loss	12.7 ksi	8.6%
Relaxation of steel loss	3.7 ksi	2.5%
Friction losses	13.0 ksi	8.8%
Total losses	40.4 ksi	27.3%

$$\text{Effective prestress} = 148 - 35.2 = 112.8 \text{ ksi}$$

$$\text{Effective prestressing force}(F) = (1 - 0.238)F_i = 0.762F_i$$

$$F = 0.762 \times 1110 = 846 \text{ K}$$

$$\text{For } F = \eta F_i, \eta = 0.762.$$

## 19.4 ANALYSIS OF FLEXURAL MEMBERS

### 19.4.1 Stresses Due to Loaded and Unloaded Conditions

In the analysis of prestressed concrete beams, two extreme loadings are generally critical. The first occurs at transfer, when the beam is subjected to the prestressing force,  $F_i$ , and the weight of the beam or the applied dead load at the time of transfer of the prestressing force. No live load or additional dead loads are considered. In this unloaded condition, the stresses at the top and bottom fibers of the critical section must not exceed the allowable stresses at transfers,  $f_{ci}$  and  $f_{ti}$ , for the compressive and tensile stresses in concrete, respectively.

The second case of loading occurs when the beam is subjected to the prestressing force after all losses  $F$  and all dead and live loads. In this loaded condition, the stresses at the top and bottom fibers of the critical section must not exceed the allowable stresses,  $f_c$  and  $f_t$ , for the compressive and tensile stresses in concrete, respectively.

These conditions can be expressed mathematically as follows:

1. For the unloaded condition (at transfer):

- At top fibers,

$$\sigma_{ti} = -\frac{F_i}{A} + \frac{(F_i e)y_t}{I} - \frac{M_D y_t}{I} \leq f_{ti} \quad (19.13)$$

- At bottom fibers,

$$\sigma_{bi} = -\frac{F_i}{A} - \frac{(F_i e)y_b}{I} + \frac{M_D y_b}{I} \geq -f_{ci} \quad (19.14)$$

2. For the loaded condition (all loads are applied after all losses):

- At top fibers,

$$\sigma_t = -\frac{F}{A} + \frac{(Fe)y_t}{I} - \frac{M_D y_t}{I} - \frac{M_L y_t}{I} \geq -f_c \quad (19.15)$$

- At bottom fibers,

$$\sigma_b = -\frac{F}{A} - \frac{(Fe)y_b}{I} + \frac{M_D y_b}{I} + \frac{M_L y_b}{I} \leq f_t \quad (19.16)$$

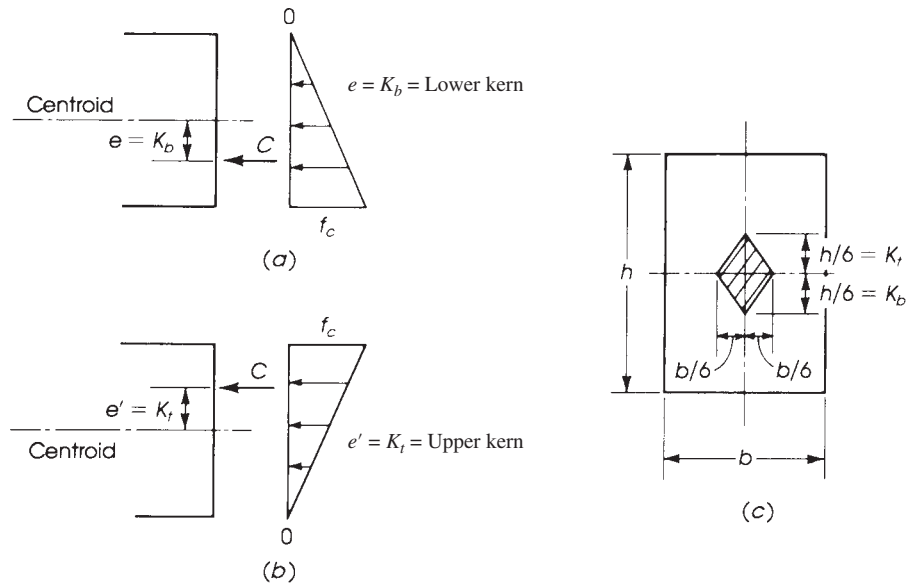
where

- $F_i, F$  = prestressing force at transfer and after all losses
- $f_{ti}, f_t$  = allowable tensile stress in concrete at transfer and after all losses
- $f_{ci}, f_c$  = allowable compressive stress in concrete at transfer and after all losses
- $M_D, M_L$  = moments due to dead load and live load
- $y_t, y_b$  = distances from neutral axis to top and bottom fibers

In this analysis, it is assumed that the materials behave elastically within the working range of stresses applied.

### 19.4.2 Kern Limits

If the prestressing force is applied at the centroid of the cross section, uniform stresses will develop. If the prestressing force is applied at an eccentricity,  $e$  below the centroid such that the stress at the top fibers is equal to 0, that prestressing force is considered acting at the lower Kern point (Fig. 19.5). In this case  $e$  is denoted by  $K_b$ , and the stress distribution is triangular, with maximum



**Figure 19.5** Kern points: (a) lower, (b) upper, and (c) central.

compressive stress at the extreme bottom fibers. The stress at the top fibers is

$$\sigma_t = -\frac{F_i}{A} + \frac{(F_i e)y_t}{I} = 0$$

$$e = K_b = \text{lower Kern} = \frac{I}{Ay_t} \quad (19.17)$$

Similarly, if the prestressing force is applied at an eccentricity  $e'$  above the centroid such that the stress at the bottom fibers is equal to 0, that prestressing force is considered acting at the upper Kern point (Fig. 19.5). In this case the eccentricity  $e'$  is denoted by  $K_t$ , and the stress distribution is triangular, with maximum compressive stress at the extreme top fibers. The stress at the bottom fibers is

$$\sigma_b = -\frac{F_i}{A} + \frac{(F_i e')y_b}{I} = 0$$

$$e' = K_t = \text{upper Kern} = \frac{I}{Ay_b} \quad (19.18)$$

The Kern limits of a rectangular section are shown in Fig. 19.5.

### 19.4.3 Limiting Values of Eccentricity

The four stress equations, Eqs. 19.13 through 19.16, can be written as a function of the eccentricity  $e$  for the various loading conditions. For example, Eq. 19.13 can be rewritten as follows:

$$\sigma_{ti} = -\frac{F_i}{A} + \frac{(F_i e)y_t}{I} - \frac{M_D y_t}{I} \leq f_{ti}$$

$$\frac{(f_i e)y_t}{I} \leq f_{ti} + \frac{F_i}{A} + \frac{M_D y_t}{I}$$

$$e \leq \frac{I}{F_i y_t} \left( \frac{F_i}{A} + \frac{M_D y_t}{I} + f_{ti} \right) \quad (19.19)$$

If the lower Kern limit  $K_b = I/Ay_t$  is used, then

$$e \leq K_b + \frac{M_D}{F_i} + \frac{f_{ti} AK_b}{F_i} \quad (19.20)$$

This value of  $e$  represents the maximum eccentricity based on the top fibers, unloaded condition. Similarly, from Eq. 19.14,

$$e \leq \frac{I}{F_i y_b} \left( -\frac{F_i}{A} + \frac{M_D y_b}{I} + f_{ci} \right) \quad (19.21)$$

$$e \leq -K_t + \frac{M_D}{F_i} + \frac{f_{ci} AK_t}{F_i} \quad (19.22)$$

This value of  $e$  represents the maximum eccentricity based on the bottom fibers, unloaded condition. The two maximum values of  $e$  should be calculated from the preceding equations and the smaller value used.

From Eq. 19.15,

$$e \geq \frac{I}{F y_t} \left( \frac{F}{A} + \frac{M_T y_t}{I} - f_c \right) \quad (19.23)$$

$$e \geq K_b + \frac{M_T}{F} - \frac{f_c AK_b}{F} \quad (19.24)$$

where  $M_T$  is the moment due to dead and live loads  $(= M_D + M_L)$ . This value of  $e$  represents the minimum eccentricity based on the top fibers, loaded condition. From Eq. 19.16,

$$e \geq \frac{I}{F y_b} \left( -\frac{F}{A} + \frac{M_T y_b}{I} - f_t \right) \quad (19.25)$$

$$e \geq -K_t + \frac{M_T}{F} - \frac{f_t AK_t}{F} \quad (19.26)$$

This value of  $e$  represents the minimum eccentricity based on the bottom fibers, loaded condition. The two minimum values of  $e$  should be calculated from the preceding equations and the larger of the two minimum eccentricities used.

#### 19.4.4 Limiting Values of the Prestressing Force at Transfer $F_i$

Considering that  $F = \eta F_i$ , where  $\eta$  represents the ratio of the net prestressing force after all losses, and for the different cases of loading, Eqs. 19.20, 19.22, 19.24, and 19.26 can be rewritten as follows:

$$(e - K_b)F_i \leq M_D + f_{ti} AK_b \quad (19.27)$$

$$(e + K_t)F_i \leq M_D + f_{ci} AK_t \quad (19.28)$$

$$(e - K_b)F_i \geq \frac{M_D}{\eta} + \frac{M_L}{\eta} - \frac{1}{\eta}(f_c AK_b) \quad (19.29)$$

$$(e + K_t)F_i \geq \frac{M_D}{\eta} + \frac{M_L}{\eta} - \frac{1}{\eta}(f_t AK_t) \quad (19.30)$$

Subtract Eq. 19.27 from Eq. 19.30 to get

$$F_i(K_b + K_t) \geq M_D \left( \frac{1}{\eta} - 1 \right) + \frac{M_L}{\eta} - \frac{f_t AK_t}{\eta} - f_{ti} AK_b$$



or

$$F_i \geq \frac{1}{K_b + K_t} \left[ \left( \frac{1}{\eta} - 1 \right) M_D + \frac{M_L}{\eta} - \left( \frac{f_t AK_t}{\eta} \right) - (f_{ti} AK_b) \right] \quad (19.31)$$

This value of  $F_i$  represents the *minimum* value of the prestressing force at transfer without exceeding the allowable stresses under the loaded and unloaded conditions. Subtract Eq. 19.29 from Eq. 19.28 to get

$$F_i \leq \frac{1}{K_b + K_t} \left[ \left( 1 - \frac{1}{\eta} \right) M_D - \frac{M_L}{\eta} + \left( \frac{f_c AK_b}{\eta} \right) + (f_{ci} AK_t) \right] \quad (19.32)$$

This value of  $F_i$  represents the *maximum* value of the prestressing force at transfer without exceeding the allowable stresses under the loaded and unloaded conditions. Subtracting Eq. 19.31 from Eq. 19.32, then

$$\left( 1 - \frac{1}{\eta} \right) 2M_D - \frac{2M_L}{\eta} + \left( f_{ti} + \frac{f_c}{\eta} \right) AK_b + \left( f_{ci} + \frac{f_t}{\eta} \right) AK_t \geq 0 \quad (19.33)$$

This equation indicates that (maximum  $F_i$ ) – (minimum  $F_i$ )  $\geq 0$ . If this equation is checked for any given section and proved to be satisfactory, then the section is adequate.

#### Example 19.4

A pretensioned simply supported beam of the section shown in Fig. 19.6a is to be used on a span of 48 ft. The beam made with normal-weight concrete must carry a dead load of 900 lb/ft (excluding its own weight), which will be applied at a later stage, and a live load of 1100 lb/ft. Assuming that prestressing steel is made of 20 tendons that are 7/16 in. in diameter, with  $E_s = 29 \times 10^6$  psi,  $F_0 = 175$  ksi, and ultimate strength  $f_{pu} = 250$  ksi, it is required to do the following:

1. Determine the location of the upper and lower limits of the tendon profile (centroid of the prestressing steel) for the section at midspan and for three other sections between the midspan section and the beam end.
2. Locate the tendon to satisfy these limits by harping some of the tendons at one-third points of the span. Check the limiting values of the prestressing force at transfer.
3. Revise the prestress losses, taking into consideration the chosen profile of the tendons and the variation of the eccentricity  $e$ .

Use  $f_{ci}$  (at transfer) = 4 ksi,  $f'_c = 5$  ksi,  $E_c = 4000$  ksi, and  $E_{ci} = 3600$  ksi.

#### Solution

1. Determine the properties of the section:

$$\text{Area} = 18 \times 6 + 24 \times 6 + 12 \times 10 = 372 \text{ in.}^2$$

Determine the centroid of the section by taking moments about the baseline:

$$y_b = \frac{1}{372} (120 \times 5 + 144 \times 22 + 108 \times 37) = 20.8 \text{ in.}$$

$$y_t = 40 - 20.8 = 19.2 \text{ in.}$$

Calculate the gross moment of inertia,  $I_g$ :

$$I_g = \left[ \frac{18(6)^3}{12} + 108(16.2)^2 \right] + \left[ \frac{6(24)^3}{12} + 144(1.2)^2 \right] + \left[ \frac{12(10)^3}{12} + 120(15.8)^2 \right]$$

$$= 66,862 \text{ in.}^4$$

$$K_b = \frac{I}{Ay_t} = \frac{66,862}{372 \times 19.2} = 9.4 \text{ in.}$$

$$K_t = \frac{I}{Ay_b} = \frac{66,862}{372 \times 20} = 8.6 \text{ in.}$$



(a)



(b)



(c)

Precast, prestressed concrete sections: (a) single T-section, (b) double T-section, and (c) U-section.

2. Estimate prestress losses, given  $F_0 = 175$  ksi.
- Assume elastic loss is 4%, or  $0.04 \times 175 = 7$  ksi.
  - Loss due to shrinkage is  $0.0003 E_s = 0.0003 \times 29,000 = 8.7$  ksi.
  - Loss due to creep of concrete: A good first estimate of creep loss is 1.67 times the elastic loss:

$$1.67 \times 7 = 11.7 \text{ ksi}$$

- Loss due to relaxation of steel is 4%:

$$0.04 \times 175 = 7 \text{ ksi}$$

Time-dependent losses are  $8.7 + 11.7 + 7 = 27.4$  ksi.

$$\text{Percentage} = \frac{27.4}{175} = 15.7\%$$

e. The total loss is  $27.4 + 7$  (elastic loss) = 34.4 ksi. The percentage of total loss is

$$\frac{34.4}{175} = 19.7\%$$

f. Prestress stresses are

$$F_i = 175 - 7 = 168 \text{ ksi} \quad (\text{at transfer})$$

$$F = 175 - 34.4 = 140.6 \text{ ksi}$$

$$F = \eta F_i$$

$\eta$  = time – dependent loss ratio

$$= \frac{140.6}{168} = 0.837$$

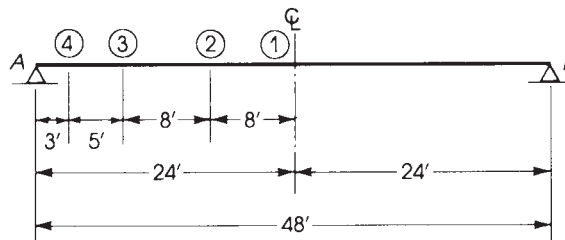
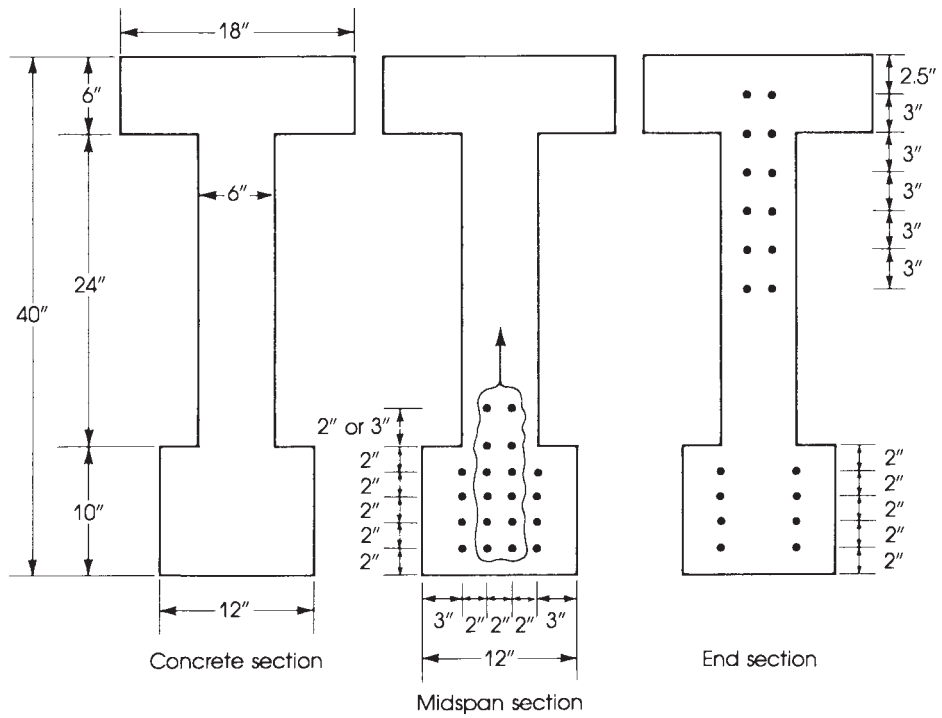


Figure 19.6a Example 19.4.

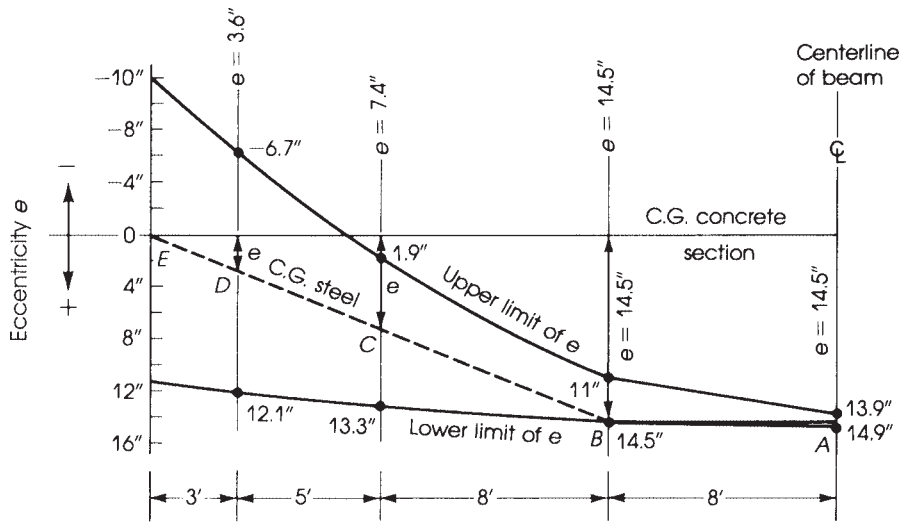


Figure 19.6b Example 19.4: Tendon profile.

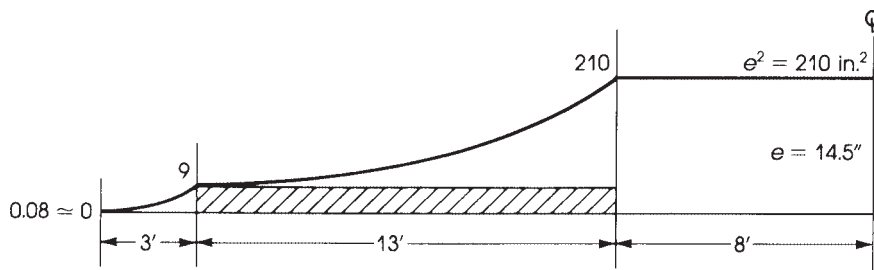


Figure 19.6c Example 19.4: Average  $e^2$ .

3. Limits of the eccentricity  $e$  at midspan section: Calculate the allowable stresses and moments. At transfer,  $f'_{ci} = 4000$  psi,  $f_{ci} = 0.6 \times 4000 = 2400$  psi, and  $f_{ti} = 3\sqrt{f'_{ci}} = 190$  psi. At service load,  $f'_c = 5000$  psi,  $f_c = 0.45f'_c = 2250$  psi, and  $f_t = 6\sqrt{f'_c} = 424$  psi.

$$\text{Self-weight of beam} = \frac{372}{144} \times 150 = 388 \text{ lb/ft}$$

$$M_D \text{ (self-weight)} = \frac{0.388}{8} (48)^2 \times 12 = 1341 \text{ K} \cdot \text{in.}$$

$$\begin{aligned} M_a \text{ (additional load and live load)} &= \frac{w_a L^2}{8} \\ &= \frac{0.9 + 1.1}{8} (48)^2 \times 12 = 6912 \text{ K} \cdot \text{in.} \end{aligned}$$

$$\text{Total moment } (M_T) = M_D + M_a = 8253 \text{ K} \cdot \text{in.}$$

$$F_i = \text{stress at transfer} \times \text{area of prestressing steel}$$

The area of 20 tendons,  $\frac{7}{16}$  in. in diameter, is  $20 \times 0.1089 = 2.178 \text{ in.}^2$

$$F_i = 2.178 \times 168 = 365.9 \text{ K}$$

$$F = 2.178 \times 140.6 = 306.2 \text{ K}$$

**a.** Consider the section at midspan. Top fibers, *unloaded* condition:

$$\begin{aligned} e &\leq K_b + \frac{M_D}{F_i} + \frac{f_{\text{ti}} AK_b}{F_i} \\ &\leq 9.4 + \frac{1341}{365.9} + \frac{0.190(372)(9.4)}{365.9} \leq 14.9 \text{ in.} \end{aligned} \quad (\text{Eq. 19.20})$$

Bottom fibers, *unloaded* condition:

$$\begin{aligned} e &\leq -K_t + \frac{M_D}{F_i} + \frac{f_{\text{ci}} AK_t}{F_i} \\ &\leq -8.6 + \frac{1341}{365.9} + \frac{2.4(372)(8.6)}{365.9} \leq 16.1 \text{ in.} \end{aligned} \quad (\text{Eq. 19.22})$$

Maximum  $e = 14.9$  in. controls.

Top fibers, *loaded* condition:

$$\begin{aligned} e &\geq K_b + \frac{M_T}{F} - \frac{f_c AK_b}{F} \\ &\geq 9.4 + \frac{8253}{306.2} - \frac{0.424(372)(8.6)}{306.2} \geq 10.7 \text{ in.} \end{aligned} \quad (\text{Eq. 19.24})$$

Bottom fibers, *loaded* condition:

$$\begin{aligned} e &\geq -K_t + \frac{M_T}{F} - \frac{f_t AK_t}{F} \\ &\geq -8.6 + \frac{8253}{306.2} - \frac{0.424(372)(8.6)}{306.2} \geq 13.9 \text{ in.} \end{aligned} \quad (\text{Eq. 19.26})$$

Minimum  $e = 13.9$  in. controls.

**b.** Consider a section 8 ft from the midspan (section 2, Fig. 19.6a):

$$\begin{aligned} M_D \text{ (self-weight)} &= R_A(16) - \frac{1}{2}w_D \times (16)^2 \\ &= 0.388(24)(16) - \frac{0.388}{2}(16)^2 = 99.3 \text{ K} \cdot \text{ft} = 1192 \text{ K} \cdot \text{in.} \end{aligned}$$

$$M_a = 2(24)(16) - \frac{2}{2}(16)^2 = 512 \text{ K} \cdot \text{ft} = 6144 \text{ K} \cdot \text{in.}$$

$$M_T = 6144 + 1192 = 7336 \text{ K} \cdot \text{in.}$$

Top fibers, *unloaded* condition:

$$e \leq 9.4 + \frac{1192}{365.9} + \frac{0.190(372)(9.4)}{365.9} \leq 14.5 \text{ in.}$$

Bottom fibers, *unloaded* condition:

$$e \leq -8.6 + \frac{1192}{365.9} + \frac{2.4(372)(8.6)}{365.9} \leq 15.6 \text{ in.}$$

Maximum  $e = 14.5$  in. controls.

Top fibers, *loaded* condition:

$$e \geq 9.4 + \frac{7336}{306.2} - \frac{2.25(372)(9.4)}{306.2} \geq 7.7 \text{ in.}$$

Bottom fibers, *loaded* condition:

$$e \geq -8.6 + \frac{7336}{306.2} - \frac{0.424(372)(8.6)}{306.2} \geq 11.0 \text{ in.}$$

Minimum  $e = 11.0$  in. controls.

- c. Consider a section 16 ft from midspan (section 3, Fig. 19.6a):  $M_D$  (self-weight) = 745 K · in.,  $M_a = 3840$  K · in., and  $M_T = 4585$  K · in.
- Top fibers, unloaded condition,  $e \leq 13.3$  in. (max) controls.
  - Bottom fibers, unloaded condition,  $e \leq 14.4$  in.
  - Top fibers, loaded condition,  $e \geq -1.3$  in.
  - Bottom fibers, loaded condition,  $e \geq 1.9$  in. (min) controls.
- d. Consider a section 3 ft from the end (anchorage length):  $M_D = 314$  K · in.,  $M_a = 1620$  K · in., and  $M_T = 1934$  K · in.
- Top fibers, unloaded condition,  $e \leq 12.1$  in. (max) controls.
  - Bottom fibers, unloaded condition,  $e \leq 13.3$  in.
  - Top fibers, loaded condition,  $e \geq -10$  in.
  - Bottom fibers, loaded condition,  $e \geq -6.7$  in. (min) controls.

4. The tendon profile is shown in Fig. 19.6. The eccentricity chosen at midspan is  $e = 14.5$  in., which is adequate for section *B* at 8 ft from midspan. The centroid of the prestressing steel is horizontal between *A* and *B* and then harped linearly between *B* and the end section at *E*. The eccentricities at sections *C* and *D* are calculated by establishing the slope of line *BE*, which is  $14.5/16 = 0.91$  in./ft. The eccentricity at *C* is 7.25 in. and at *D* it is 2.72 in. The tendon profile chosen satisfies the upper and lower limits of the eccentricity at all sections.

Harping of tendons is performed as follows:

- a. Place the 20 tendons ( $\frac{7}{16}$  diameter) within the middle third of the beam at spacings of 2 in., as shown in Fig. 19.6a. To calculate the actual eccentricity at midspan section, take moments for the number of tendons about the baseline of the section:

$$\text{Distance from base} = \frac{1}{20}(16 \times 5 + 4 \times 11) = 6.2 \text{ in.}$$

$$e \text{ (midspan)} = y_b - 6.2 \text{ in.}$$

$$= 20.8 - 6.2 = 14.6 \text{ in.}$$

which is close to the 14.5 in. assumed. If the top two tendons are placed at 3 in. from the row below them, then the distance from the base becomes  $\frac{1}{20}(16 \times 5 + 2 \times 10 + 2 \times 13) = 6.3$  in. The eccentricity becomes  $20.8 - 6.3 = 14.5$  in., which is equal to the assumed eccentricity. Practically, all tendons may be left at 2 in. spacing by neglecting the difference of 0.1 in.

- b. Harp the central 12 tendons only. The distribution of tendons at the end section is shown in Fig. 19.6a. To check the eccentricity of tendons, take moments about the centroid of the concrete section for the 12 tendons at top and the 8 tendons left at bottom:

$$e = \frac{1}{20}(8 \times 14.5 - 12 \times 9.2) = 0.28 \text{ in.}$$

This value of  $e$  is small and adequate. The actual eccentricity at 3 ft from the end section is

$$e = \frac{3}{16}(14.5 - 0.28) + 0.28 = 2.95 \text{ in.} \quad (3 \text{ in.})$$

The actual eccentricity at 8 ft from the end section is

$$e = \frac{1}{2}(14.5 - 0.28) + 0.28 = 7.4 \text{ in.}$$

5. Limited values of  $F_i$ : The value of  $F_i$  used in the preceding calculations is  $F_i = 365.9$  K. Check minimum  $F_i$  by Eq. 19.31:

$$\begin{aligned} \text{Min. } F_i &= \frac{1}{K_b + K_t} \left[ \left( \frac{1}{\eta} - 1 \right) M_D + \frac{M_L}{\eta} - \frac{f_t AK_t}{\eta} \right] - (f_{ti} AK_b) \\ &= \frac{1}{9.4 + 8.6} \left[ \left( \frac{1}{0.8423} - 1 \right) 1341 + \frac{6912}{0.843} \right. \\ &\quad \left. - \frac{0.424 \times 372 \times 8.6}{0.843} (0.19 \times 372 \times 9.4) \right] = 343.1 \text{ K} \end{aligned}$$

which is less than the  $F_i$  used. Check maximum  $F_i$  using Eq. 19.32:

$$\begin{aligned} \text{Max. } F_i &= \frac{1}{K_b + K_t} \left[ \left( 1 - \frac{1}{\eta} \right) M_D - \frac{M_L}{\eta} + \frac{f_c AK_b}{\eta} + (f_{ci} AK_t) \right] \\ &= \frac{1}{18} \left[ \left( 1 - \frac{1}{0.843} \right) 1341 - \frac{6912}{0.843} + \frac{(2.25 \times 3.72 \times 9.4)}{0.843} + (2.4 \times 3.72 \times 8.6) \right] \\ &= 475.7 \text{ K} \end{aligned}$$

which is greater than the  $F_i$  used. Therefore, the critical section at midspan is adequate.

6. Check prestress losses, recalling that  $F_0 = 175$  ksi and  $A_{ps} = 2.178$  in.<sup>2</sup>

$$\text{Total } F_0 = 2.178 \times 175 = 381 \text{ K}$$

$$E_c = 4000 \text{ ksi}$$

$$n = \frac{E_s}{E_c} = \frac{29}{4.0} = 7.25$$

where  $n$  can be assumed to be 7, and  $M_D$  at midspan = 1341 K · in.

$$F_i = \frac{F_0 + nA_{ps}f_c (\text{DL}) \times \frac{2}{3}}{1 + (nA_{ps})(1/A + e^2/I)} \quad (\text{Eq. 19.5})$$

The value of  $f_c$  due to the distributed dead load is multiplied by  $\frac{2}{3}$  to reflect the parabolic variation of the dead-load stress along the span, giving a better approximation of  $F_i$ .

- a. Determine the average value of  $e^2$ , as adopted in the beam. The curve representing  $e^2$  is shown in Fig. 19.6a:

$$\begin{aligned} \text{Average } e^2 &= \frac{1}{24} \left[ \left( \frac{1}{3} \times 3 \times 9 \right) + (9 \times 13) + \left( \frac{1}{3} \times 13 \times 201 \right) + (210 \times 8) \right] \\ &= 111.5 \text{ in.}^2 \\ e &= 10.56 \text{ in.} \end{aligned}$$

The area of a parabola is one-third the area of its rectangle.

- b. Stress due to dead load at the level of the tendons is

$$f_c(\text{DL}) = \frac{1341 \times 10.56}{66,862} = 0.212 \text{ ksi}$$

Therefore,

$$F_i = \frac{381 + 7(2.178) \times 0.212 \times 2/3}{1 + (7 \times 2.178) \left( \frac{1}{372} + \frac{111.5}{66,862} \right)} = 358 \text{ K}$$

Elastic loss is  $381 - 358 = 23 \text{ K} = 6.1\%$ . This value is greater than the assumed elastic loss of 4%.

$$\text{Elastic loss per unit steel area} = \frac{23}{2.178} = 10.6 \text{ ksi}$$

$$F_i \text{ per unit steel area} = \frac{358}{2.178} = 164.4 \text{ ksi}$$

c. Time-dependent losses:

Loss due to shrinkage is 8.7 ksi (as before). Loss due to creep :

$$\text{Elastic strain} = \frac{F_i}{A_c E_c} = \frac{358}{372 \times 4000} = 0.240 \times 10^{-3}$$

$$\Delta f_s = C_c (\epsilon_{cr} E_s)$$

Let  $C_c = 1.5$ . Then

$$\Delta f_s = 1.5(0.24 \times 10^{-3} \times 29,000) = 10.4 \text{ ksi}$$

$$\text{Percent loss} = \frac{10.4}{164.4} = 6.3\%$$

Loss due to relaxation of steel is 7 ksi (as before). Time-dependent losses equal  $8.7 + 10.4 + 7 = 26.1 \text{ ksi}$ , for a percentage loss of  $26.1/164.4 = 15.8\%$ , which is very close to the previously estimated value of 15.7%.

$$F = \eta F_i = (1 - 0.158)F_i = 0.842F_i$$

$$\eta = 0.842$$

## 19.5 DESIGN OF FLEXURAL MEMBERS

### 19.5.1 General

The previous section emphasized that the stresses at the top and bottom fibers of the critical sections of a prestressed concrete member must not exceed the allowable stresses for all cases or stages of loading. In addition to these conditions, a prestressed concrete member must be designed with an adequate factor of safety against failure. The ACI Code requires that the moment due to the factored service loads,  $M_u$ , must not exceed  $\phi M_n$ , the flexural strength of the designed cross section.

For the case of a tension-controlled, prestressed concrete beam, failure begins when the steel stress exceeds the yield strength of steel used in the concrete section. The high-tensile prestressing steel will not exhibit a definite yield point, such as that of the ordinary mild steel bars used in reinforced concrete. But under additional increments of load, the strain in the steel increases at an accelerated rate, and failure occurs when the maximum compressive strain in the concrete reaches a value of 0.003 (Fig. 19.7).

The limits for reinforcement of prestressed concrete flexural members according to the ACI Code, Sections 7.6.2, 8.6.2, and 9.6.2, is based on the net tensile strain for tension-controlled, transition, or compression-controlled sections in accordance with the ACI Code, Section 21.2.2.2, as was explained here in this textbook, Section 3.5. The strength reduction factor,  $\phi$ , was given earlier in Section 3.7 of this textbook based on the ACI Code, Section 21.2.1.



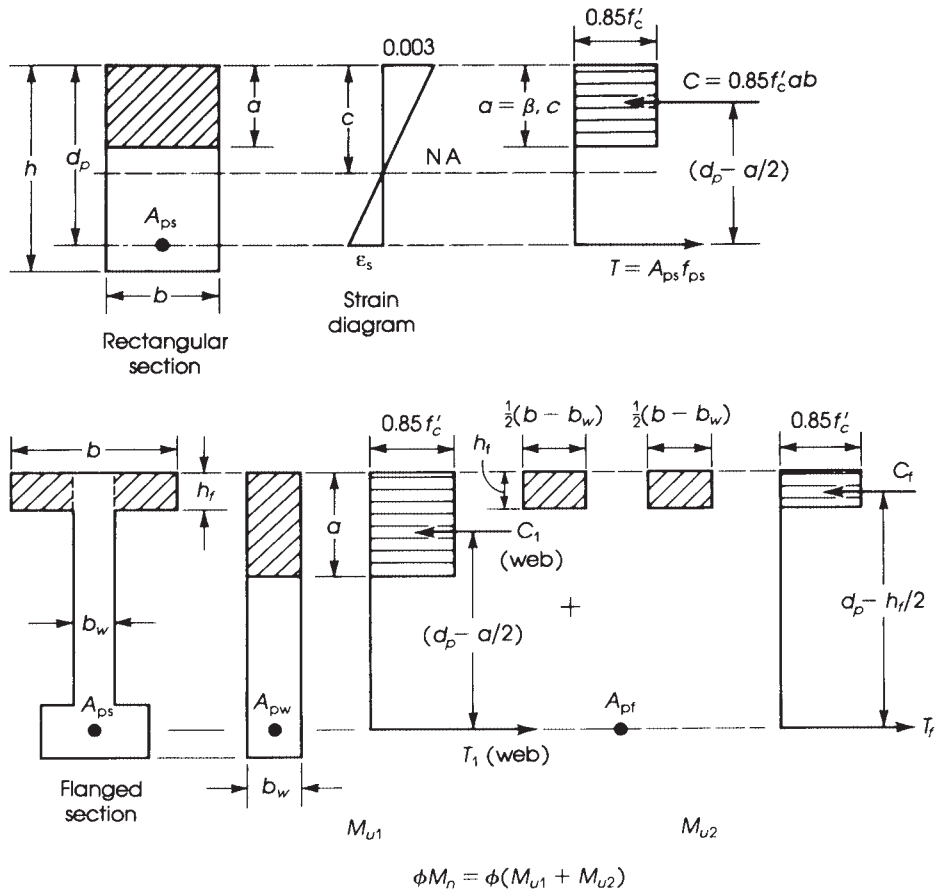


Figure 19.7 Factored moment capacity of prestressed concrete beams.

### 19.5.2 Rectangular Sections

The nominal moment capacity of a rectangular section may be determined as follows (refer to Fig. 19.7):

$$M_n = C \left( d_p - \frac{1}{2}a \right) = T \left( d_p - \frac{1}{2}a \right) \quad (19.34)$$

where  $T = A_{ps} f_{ps}$  and  $C = 0.85 f'_c ab$ . For  $C = T$ ,

$$a = \frac{A_{ps} f_{ps}}{0.85 f'_c b} = \frac{\rho_p f_{ps}}{0.85 f'_c} d_p \quad (19.35)$$

where the prestressing steel ratio is  $\rho_p = A_{ps}/bd_p$ , and  $A_{ps}$  and  $f_{ps}$  refer to the area and tensile stress of the prestressing steel. Let

$$\omega_p = \rho_p \left( \frac{f_{ps}}{f'_c} \right) \leq 0.32\beta_1$$

Then

$$a = \frac{\omega_p}{0.85} d_p \quad (19.36)$$

The quantity  $\omega_p$  is a direct measure of the force in the tendon. To ensure a tension-controlled behavior,  $\omega_p$  must not exceed  $0.32\beta_1$ , which corresponds to a net tensile strain,  $\epsilon_t$ , of 0.005. Note that the value of  $\beta_1 = 0.85$  for  $f'_c \leq 4$  ksi and reduces by 0.05 for each 1 ksi greater than 4 ksi (ACI Code, Section 22.2.2.4.3).  $M_n$  can also be written as follows:

$$M_n = \begin{cases} A_{ps} f_{ps} \left( d_p - \frac{1}{2} a \right) \\ A_{ps} f_{ps} d_p \left( 1 - \frac{\rho_p f_{ps}}{1.7 f'_c} \right) \\ A_{ps} f_{ps} d_p \left( 1 - \frac{\omega_p}{1.7} \right) \end{cases} \quad (19.37)$$

$$(19.38)$$

and  $M_u = \phi M_n$ .

In the preceding equations,  $f_{ps}$  indicates the stress in the prestressing steel at failure. The actual value of  $f_{ps}$  may not be easily determined. Therefore, the ACI Code, Section 20.3.2.3.1, permits  $f_{ps}$  to be evaluated as follows (all stresses are in psi). For *bonded* tendons,

$$f_{ps} = f_{pu} \left[ 1 - \frac{\gamma_p}{\beta_1} \left( \rho_p \times \frac{f_{pu}}{f'_c} \right) \right] \quad (19.39)$$

For *unbonded* tendons in members with a span-to-depth ratio less than or equal to 35,

$$f_{ps} = \left( f_{se} + 10,000 + \frac{f'_c}{100\rho_p} \right) \leq f_{py} \quad (19.40)$$

provided that  $f_{se} \geq 0.5 f_{pu}$  and that  $f_{ps}$  for unbonded tendons does not exceed either  $f_{py}$  or  $f_{se} + 60,000$  psi. For *unbonded* tendons in members with a span-to-depth ratio greater than 35,

$$f_{ps} = \left( f_{se} + 10,000 + \frac{f'_c}{300\rho_p} \right) \quad (19.41)$$

but not greater than  $f_{py}$  or  $f_{se} + 30,000$  psi, where

$\gamma_p$  = factor for type of prestressing tendon

$$= \begin{cases} 0.55 & \text{for } f_{py}/f_{pu} \text{ not less than } 0.8 \\ 0.4 & \text{for } f_{py}/f_{pu} \text{ not less than } 0.85 \\ 0.28 & \text{for } f_{py}/f_{pu} \text{ not less than } 0.9 \end{cases}$$

$f_{pu}$  = specified tensile strength of prestressing steel

$f_{se}$  = effective stress in prestressing steel after all losses

$f_{py}$  = specified yield strength of prestressing steel

In the event that  $\omega_p > 0.32 \beta_1$ , a compression-controlled, prestressed concrete beam may develop. To ensure a ductile failure,  $\omega_p$  is limited to a maximum value of  $0.32\beta_1$ . For  $\omega_p = 0.32\beta_1$ ,

$a = 0.377 \beta_1 d_p$  (from Eq. 19.36). Substituting this value of  $a$  in Eq. 19.38,

$$\begin{aligned} M_n &= A_{ps} f_{ps} d_p \left( 1 - \frac{0.32 \beta_1}{1.7} \right) \\ &= (\rho_p b d_p) f_{ps} d_p (1 - 0.188 \beta_1) \\ &= \omega_p f'_c (1 - 0.188 \beta_1) b d_p^2 \\ &= (0.32 \beta_1 - 0.06 \beta_1^2) f'_c b d_p^2 \end{aligned} \quad (19.42)$$

for  $f'_c = 5$  ksi,  $\beta_1 = 0.8$ . Then

$$M_n = 0.22 f'_c b d_p^2 = 1.09 b d_p^2$$

Similarly, for  $f'_c = 4$  ksi,  $M_n = 0.915 b d_p^2$ , and for  $f'_c = 6$  ksi,  $M_n = 1.238 b d_p^2$ .

### 19.5.3 Flanged Sections

For flanged sections (T- or I-sections), if the stress block depth  $a$  lies within the flange, it will be treated as a rectangular section. If  $a$  lies within the web, then the web may be treated as a rectangular section using the web width,  $b_w$ , and the excess flange width ( $b - b_w$ ) will be treated similarly to that of reinforced concrete T-sections discussed in Chapters 3 and 4. The design moment strength of a flanged section can be calculated as follows (see Fig. 19.7):

$$\begin{aligned} M_n &= M_{n_1} \text{ (moment strength of web)} + M_{n_2} \text{ (moment strength of excess flange)} \\ &= A_{pw} f_{ps} \left( d_p - \frac{1}{2} a \right) + A_{pf} f_{ps} \left( d_p - \frac{1}{2} h_f \right) \\ M_u &= \phi M_n \quad \text{and} \quad a = \frac{A_{pw} f_{ps}}{0.85 f'_c b_w} \end{aligned} \quad (19.43)$$

where

$$\begin{aligned} A_{pw} &= A_{ps} - A_{pf} \\ A_{pf} &= [0.85 f'_c (b - b_w) h_f] / f_{ps} \\ h_f &= \text{thickness of flange} \end{aligned}$$

Note that the total prestressed steel,  $A_{ps}$ , is divided into two parts,  $A_{pw}$  and  $A_{pf}$ , developing the web and flange moment capacity. For flanged sections, the reinforcement index,  $\omega_{pw}$ , must not exceed  $0.32 \beta_1$  for tension-controlled sections, where

$$\omega_{pw} = \left( \frac{A_{pw}}{b_w d_p} \right) \left( \frac{f_{ps}}{f'_c} \right) = \text{prestressed web steel ratio} \times \left( \frac{f_{ps}}{f'_c} \right)$$

### 19.5.4 Partial Prestressed Reinforcement

In some cases, nonprestressed reinforcing bars ( $A_s$ ) are placed in the tension zone of a prestressed concrete flexural member together with the prestressing steel ( $A_{ps}$ ) to increase the moment strength of the beam. In this case, the total steel ( $A_{ps}$  and  $A_s$ ) is considered in the moment analysis. For rectangular sections containing prestressed and nonprestressed steel, the design moment strength,  $\phi M_n$ , may be computed as follows:

$$M_n = A_{ps} f_{ps} \left( d_p - \frac{1}{2} a \right) + A_s f_y \left( d - \frac{1}{2} a \right) \quad (19.44)$$

where

$$a = \frac{A_{ps}f_{ps} + A_s f_y}{0.85 f'_c b}$$

Also,  $d_p$  and  $d$  are the distances from extreme compression fibers to the centroid of the prestressed and nonprestressed steels, respectively. For flanged sections,

$$M_n = A_{pw}f_{ps} \left( d_p - \frac{a}{2} \right) + A_s f_y \left( d - \frac{a}{2} \right) + A_{pf} f_y \left( d_p - \frac{h_f}{2} \right) \quad (19.45)$$

where

$$A_{pw} = A_{ps} - A_{pf}$$

$$a = \frac{A_{ps}f_{ps} + A_s f_y}{0.85 f'_c b_w}$$

For rectangular sections with compression reinforcement, and taking moments about the force  $C$ ,

$$M_n = A_{ps}f_{ps} \left( d_p - \frac{a}{2} \right) + A_s f_y \left( d - \frac{a}{2} \right) + A'_s f_y \left( \frac{a}{2} - d' \right) \quad (19.46)$$

where

$$a = \frac{A_{ps}f_{ps} + A_s f_y - A'_s f_y}{0.85 f'_c b}$$

This equation is valid only if compression steel yields. The condition for compression steel to yield is

$$\frac{A_{ps}f_{ps} + A_s f_y - A'_s f_y}{bd} \geq 0.85 \beta_1 \frac{f'_c d'}{d} \left( \frac{87}{87 - f_y} \right)$$



Prestressed concrete beds for slabs and wall panels.

If this condition is not met, then compression steel does not yield. In this case,  $A'_s$  may be neglected (let  $A'_s = 0$ ), or alternatively, the stress in  $A'_s$  may be determined by general analysis, as explained in Chapter 3.

When prestressed and nonprestressed reinforcement are used in the same section, Eq. Eq. 19.39 should read as follows:

$$f_{ps} = f_{pu} \left[ 1 - \frac{\gamma_p}{\beta_1} \left( \rho_p \frac{f_{pu}}{f'_c} + \frac{d}{d_p} (\omega - \omega') \right) \right] \quad (19.47)$$

(ACI Code, Section 20.3.2.3.1). If any compression reinforcement is taken into account when calculating  $f_{ps}$ , the term

$$\rho_p \frac{f_{pu}}{f'_c} + \frac{d}{d_p} (\omega - \omega')$$

must be greater than or equal to 0.17 and  $d'$  must be less than or equal to  $0.15d_p$ , where  $d$ ,  $d'$ , and  $d_p$  are the distances from the extreme compression fibers to the centroid of the nonprestressed tension steel, compression steel, and prestressed reinforcement, respectively,

$\gamma_p$  = factor for type of prestressing tendon

$$= \begin{cases} 0.55 & \text{for } \frac{f_{py}}{f_{pu}} \text{ not less than } 0.8 \\ 0.40 & \text{for } \frac{f_{py}}{f_{pu}} \text{ not less than } 0.85 \\ 0.28 & \text{for } \frac{f_{py}}{f_{pu}} \text{ not less than } 0.90 \end{cases}$$

$$\beta_1 = 0.85 \quad \text{for } f'_c \leq 4 \text{ ksi less } 0.05 \quad \text{for each 1 ksi increase in } f'_c, \text{ but } \beta_1 \geq 0.65.$$

1. For rectangular sections, the ACI Code, Section 21.2.2.2, limits the reinforcement ratio as follows ( $\epsilon_t \geq 0.005$  for tension-controlled sections):

$$\omega_p + \frac{d}{d_p} \omega \leq 0.32\beta_1$$

where

$$\omega_p = \rho_p \left( \frac{f_{ps}}{f'_c} \right) \quad \text{and} \quad \rho_p = \frac{A_{ps}}{bd} \quad (\text{prestressed steel})$$

$$\omega = \rho \left( \frac{f_y}{f'_c} \right) \quad \text{and} \quad \rho = \frac{A_s}{bd} \quad (\text{nonprestressed steel})$$

2. If ordinary reinforcing bars  $A'_s$  are used in the compression zone, then the condition becomes

$$\omega_p + \frac{d}{d_p} (\omega - \omega') \leq 0.32\beta_1$$

where  $\omega' = \rho'(f_y/f'_c)$  and  $\rho' = A'_s/bd$ . This reinforcement limitation is necessary to ensure a plastic failure of underreinforced concrete beams.

3. For flanged sections, the steel area required to develop the strength of the web ( $A_{pw}$ ) is used to check the reinforcement index.

$$\omega_{pw}(\text{web}) = \rho_{pw} \left( \frac{f_{ps}}{f'_c} \right) \leq 0.32\beta_1$$

where

$$\rho_{pw} = \frac{A_{pw}}{b_w d_d}$$

If nonprestressed reinforcement is used, then the reinforcement limitations are

$$\omega_{pw} + \frac{d}{d_{pw}}(\omega_w - \omega'_w) \leq 0.32\beta_1$$

where

$$\omega_w = \frac{A_s}{b_w d} \left( \frac{f_y}{f'_c} \right) \quad \omega'_w = \frac{A'_s}{b_w d} \left( \frac{f_y}{f'_c} \right)$$

When compression steel  $A'_s$  is not used, then  $\omega'_w = 0$ . The preceding reinforcement conditions must be met in the analysis and design of partially prestressed concrete members.

For class C of prestressed concrete flexural members, where  $f_t > 12\sqrt{f'_c}$  (cracked section), crack control provisions should be used as explained in Section 6.7 of this textbook. When using Eq. 6.18 for the maximum spacing  $s$ , the ACI Code, Section 24.3.2, specifies the following:

- a. For tendons, use  $\frac{2}{3}$  of the spacing  $s$ .
- b. For a combination of nonprestressed reinforcement and tendons, use  $\frac{5}{6}$  of the spacing  $s$ .
- c. For tendons, use  $\Delta f_{ps}$  in place of  $f_s$ , where  $\Delta f_{ps}$  is the difference between the stress computed in the prestressing tendons at service load based on a cracked section and the decompression stress,  $f_{dc}$ , in the prestressing tendons, which may be taken conservatively, to be equal to the effective prestress,  $f_{se}$ . Note that  $\Delta f_{ps}$  should not exceed 36 ksi. If it is less than or equal to 20 ksi, the spacing requirement will not apply. Equation 6.17 can be written as follows:

$$s = \left( \frac{2}{3} \right) \left[ 15 \left( \frac{40}{\Delta f_{ps}} \right) - 2.5C_c \right]$$

## 19.6 CRACKING MOMENT

Cracks may develop in a prestressed concrete beam when the tensile stress at the extreme fibers of the critical section equals or exceeds the modulus of rupture of concrete,  $f_r$ . The value of  $f_r$  for normal-weight concrete may be assumed to be equal to  $7.5\lambda\sqrt{f'_c}$  where  $\lambda = 1.0$ . The stress at the bottom fibers of a simply supported beam produced by the prestressing force and the cracking moment is

$$\sigma_b = -\frac{F}{A} - \frac{(Fe)y_b}{I} + \frac{M_{cr}y_b}{I}$$

When  $\sigma_b = f_r = 7.5\lambda\sqrt{f'_c}$ , then the cracking moment is

$$M_{cr} = \frac{I}{y_b} \left( 7.5\lambda\sqrt{f'_c} + \frac{F}{A} + \frac{(Fe)y_b}{I} \right) \quad (19.48)$$

The maximum tensile stress after all losses is  $7.5\lambda\sqrt{f'_c}$ , which represents  $f_r$ . In this case, prestressed concrete beams may remain uncracked at service loads. To ensure adequate strength against cracking, the ACI Code, Sections 8.6.2.2 requires that the factored moment of the member  $\phi M_n$  be at least 1.2 times the cracking moment,  $M_{cr}$ .

### Example 19.5

For the beam of Example 19.4, check the design strength and cracking moment against the ACI Code requirements.

### Solution

1. Check if the stress block depth  $a$  lies within the flange.

$$a = \frac{A_{ps}f_{ps}}{0.85f'_c b} \quad (\text{Eq. 19.35})$$

$$A_{ps} \left( \text{of 20 tendons } \frac{7}{16} \text{ in. in diameter} \right) = 2.178 \text{ in.}^2$$

Let  $f_{py}/f_{pu} = 0.85$ ,  $\rho_p = 0.4$ , and  $\gamma_p/\beta_1 = 0.4/0.8 = 0.5$ . For bonded tensions,

$$f_{ps} = f_{pu} \left( 1 - \frac{\gamma_p}{\beta_1} \rho_p \times \frac{f_{pu}}{f'_c} \right) \quad (\text{Eq. 19.39})$$

$$d_p = 40 - 6.3 = 33.7 \text{ in.}$$

$$\rho_p = \frac{A_{ps}}{bd_p} = \frac{2.178}{18 \times 33.7} = 0.00359$$

Given  $f_{pu} = 250$  ksi,

$$f_{ps} = 250 \left[ 1 - 0.5(0.00359) \times \frac{250}{5} \right] = 228 \text{ ksi}$$

$$a = \frac{2.178 \times 228}{0.85 \times 5 \times 18} = 6.5 \text{ in.}$$

which is greater than 6 in. Therefore, the section acts as a flanged section.

2. For flanged sections,

$$M_n = A_{pw}f_{ps} \left( d_p - \frac{1}{2}a \right) + A_{pf}f_{ps} \left( d_p - \frac{1}{2}h_f \right)$$

where

$$A_{pw} \text{ (web)} = A_{ps} - A_{pf} \text{ (flange)}$$

$$A_{pf} = \frac{1}{f_{ps}} [0.85f'_c(b - b_w)h_f]$$

$$= \frac{1}{228} [0.85 \times 5(18 - 6)6] = 1.342 \text{ in.}^2$$

$$A_{pw} = 2.178 - 1.342 = 0.836 \text{ in.}^2$$

$$a = \frac{A_{pw}f_{ps}}{0.85f'_c b_w} = \frac{0.836(228)}{0.85 \times 5 \times 6} = 7.5 \text{ in.}$$

$$M_n = 0.836(228) \left(33.7 - \frac{7.5}{2}\right) + 1.342 \times 228 \left(33.7 - \frac{6}{2}\right)$$

$$= 15,102 \text{ K} \cdot \text{in.} = 1258.5 \text{ K} \cdot \text{ft}$$

$$\phi M_n = 0.9(1258.5) = 1132.7 \text{ K} \cdot \text{ft}$$

Check the reinforcement index for the flanged section:

$$\rho_{pw} \text{ (web)} = \frac{A_{pw}}{b_w d_p} = \frac{0.836}{6 \times 33.7} = 0.00413$$

$$\omega_{pw} \text{ (web)} = \rho_{pw} \frac{f_{ps}}{f'_c} \leq 0.32\beta_1 = 0.32 \times 0.8 = 0.256$$

( $\beta_1 = 0.8$  for  $f'_c = 5$  ksi.)

$$\omega_{pw} = 0.00413 \frac{228}{5} = 0.188 < 0.256 \quad \phi = 0.9$$

3. Calculate the external factored moment due to dead and live loads:

Dead load = self – weight + additional dead load

$$= 0.388 + 0.9 = 1.29 \text{ K/ft}$$

Live load = 1.1 K/ft

$$U = 1.2D + 1.6L$$

$$M_u = \frac{(48)^2}{8} [1.2(1.29) + 1.6(1.1)] = 952.7 \text{ K} \cdot \text{ft}$$

This external moment is less than the factored moment capacity of the section of 1132.7 K · ft; therefore, the section is adequate.

4. The cracking moment (Eq. 19.48) is

$$M_{cr} = \frac{I}{y_b} \left( 7.5\lambda\sqrt{f'_c} + \frac{F}{A} + (Fe)\frac{y_b}{I} \right)$$

From Example 19.4  $F = 306.2 \text{ K}$ ,  $A = 372 \text{ in.}^2$ ,  $e = 14.5 \text{ in.}$ ,  $y_b = 20.8 \text{ in.}$ ,  $I = 66,862 \text{ in.}^4$ ,  $f'_c = 5 \text{ ksi}$ , and  $7.5\lambda\sqrt{f'_c} = 7.55000 = 530 \text{ psi}$ .

$$M_{cr} = \frac{66,862}{20.8} \left[ 0.53 + \frac{306.2}{372} + \frac{(306.2)(14.5)(20.8)}{66,862} \right]$$

$$= 8790 \text{ K} \cdot \text{in.} = 732.5 \text{ K} \cdot \text{ft}$$

Check that  $1.2 M_{cr} \leq \phi M_n$ .

$$1.2M_{cr} = 1.2(732.5) = 879 \text{ K} \cdot \text{ft}$$

This value is less than  $\phi M_n = 1132.7 \text{ K} \cdot \text{ft}$ . Thus, the beam is adequate against cracking.

## 19.7 DEFLECTION

Deflection of a point in a beam is the total movement of the point, either downward or upward, due to the application of load on that beam. In a simply supported prestressed concrete beam, the prestressing force is usually applied below the centroid of the section, causing an upward deflection



called *camber*. The self-weight of the beam and any external gravity loads acting on the beam will cause a downward deflection. The net deflection will be the algebraic sum of both deflections.

In computing deflections, it is important to consider both the short-term, or immediate, deflection and the long-term deflection. To ensure that the structure remains serviceable, the maximum short- and long-term deflections at all critical stages of loading must not exceed the limiting values specified by the ACI Code (see Section 6.3 in this text).

The deflection of a prestressed concrete member may be calculated by standard deflection equations or by the conventional methods given in books on structural analysis. For example, the midspan deflection of a simply supported beam subjected to a uniform gravity load  $w$  is equal to  $(5wL^4/384EI)$ . The modulus of elasticity of concrete is  $E_c = 33\omega^{1.5}\sqrt{f'_c} = 57,000\sqrt{f'_c}$  for normal-weight concrete.

The moment of inertia of the concrete section  $I$  is calculated based on the properties of the gross section for an uncracked beam. This case is appropriate when the maximum tensile stress in the concrete extreme fibers does not exceed the modulus of rupture of concrete,  $f_r = 7.5\sqrt{f'_c}$  (class U beams). When the maximum tensile stress based on the properties of the gross section exceeds  $7.5\sqrt{f'_c}$ , the effective moment of inertia,  $I_e$ , based on the cracked and uncracked sections must be used as explained in Chapter 6 (class T and C beams). Typical midspan deflections for simply supported beams due to gravity loads and prestressing forces are shown in Table 19.3.

### Example 19.6

For the beam of Example 19.4, calculate the camber at transfer and then calculate the final anticipated immediate deflection at service load.

#### Solution

##### 1. Deflection at transfer:

- a. Calculate the downward deflection due to dead load at transfer, self-weight in this case. For a simply supported beam subjected to a uniform load,

$$\Delta_D \text{ (dead load)} = \frac{5wL^4}{384EI}$$

From Example 19.4,  $w_D = 388$  lb/ft,  $L = 48$  ft,  $E_{ci} = 3600$  ksi, and  $I = 66,862$  in.<sup>4</sup>

$$\Delta_D = \frac{5(0.388/12)(48 \times 12)^4}{384(3600)(66,862)} = 0.192 \text{ in. (downward)}$$

- b. Calculate the camber due to the prestressing force. For a simply supported beam harped at one-third points with the eccentricity  $e_1 = 14.5$  in. at the middle third and  $e_2 = 0$  at the ends,

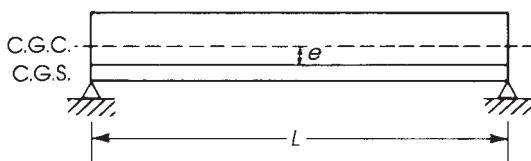
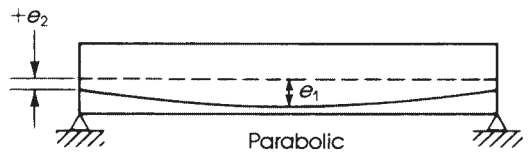
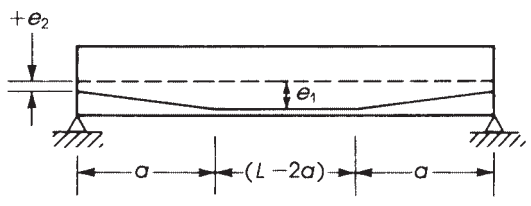
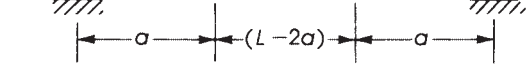

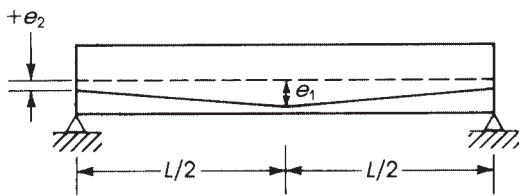
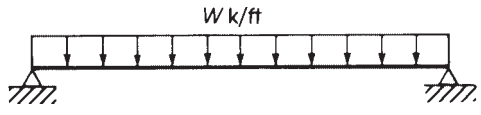
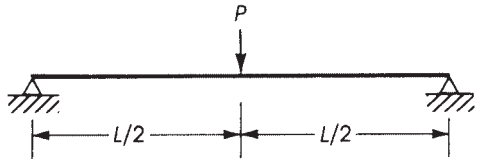
$$\begin{aligned} \Delta_p &= \frac{23(F_i e_1)L^2}{216E_{ci}I} && \text{(Table 19.3)} \\ &= \frac{23(365.9 \times 14.5)(48 \times 12)^2}{216(3600)(66,862)} = -0.779 \text{ in. (upward)} \end{aligned}$$

- c. Final camber at transfer is  $-0.779 + 0.192 = -0.587$  in. (upward).

2. Deflection at service load: The total uniform service load is  $W_T = 0.388 + 0.9 + 1.1 = 2.388$  K/ft, and  $E_c = 4000$  ksi. The downward deflection due to  $W_T$  is

$$\Delta_w = \frac{5W_T L^4}{384E_c I} = \frac{5(2.388/12)(48 \times 12)^4}{384(4000)(66,862)} = +1.067 \text{ in. (downward)}$$

**Table 19.3** Midspan Deflections of Simply Supported Beams

Schematic	Deflection Equations
Camber due to prestressing force	
 <p style="text-align: center;">C.G.C. = Centroid (concrete) C.G.S. = Centroid (steel)</p>	$\Delta = \frac{(Fe)L^2}{8EI} \quad (1)$ <p>(Horizontal tendons)</p>
 <p style="text-align: center;">Parabolic</p>	$\Delta = \frac{FL^2}{8EI} \left[ \frac{5}{6}e_1 + \frac{1}{6}e_2 \right] \quad (2)$
<p>When <math>e_2 = 0</math></p>	$\Delta = \frac{5(Fe_1)L^2}{48EI} \quad (3)$
	$\Delta = \frac{FL^2}{8EI} \left[ e_1 + \frac{4}{3} \left( \frac{a}{L} \right)^2 (e_2 - e_1) \right] \quad (4)$
<p>When <math>a = \frac{1}{3}L</math>:</p>	$\Delta = \frac{FL^2}{8EI} \left[ e_1 + \frac{4}{27} (e_2 - e_1) \right] \quad (5)$
	<p>When <math>a = \frac{1}{3}L</math> and <math>e_2 = 0</math></p>
	$\Delta = \frac{23(Fe_1)L^2}{216EI} \quad (6)$
	$\Delta = \frac{FL^2}{24EI} [2e_1 + e_2] \quad (7)$
<p>When <math>e_2 = 0</math>:</p>	$\Delta = \frac{(Fe_1)L^2}{12EI} \quad (8)$
Deflection due to gravity loads	
	$\Delta = \frac{5wL^4}{834EI} \quad (9)$
	$\Delta = \frac{PL^3}{48EI} \quad (10)$



The camber due to prestressing force  $F = 306.2$  K and  $E_c = 4000$  ksi is

$$\Delta_p = \frac{23(306.2 \times 14.5)(48 \times 12)^2}{216(4000)(66,862)} = -0.587 \text{ in. (upward)}$$

The final immediate deflection at service load is

$$\Delta = \Delta_w - \Delta_p = 1.067 - 0.587 = +0.48 \text{ in. (downward)}$$

## 19.8 DESIGN FOR SHEAR

The design approach to determine the shear reinforcement in a prestressed concrete beam is almost identical to that used for reinforced concrete beams. Shear cracks are assumed to develop at  $45^\circ$  measured from the axis of the beam. In general, two types of shear-related cracks form. One type is due to a combined effect of flexure and shear: The cracks start as flexural cracks and then deviate and propagate at an inclined direction due to the effect of diagonal tension. The second type, web-shear cracking, occurs in beams with narrow webs when the magnitude of principal tensile stress is high in comparison to flexural stress. Stirrups must be used to resist the principal tensile stresses in both cases. The ACI design criteria for shear will be adopted here.

### 19.8.1 Basic Approach

The ACI design approach is based on ultimate strength requirements using the load factors mentioned in Chapter 3. When the factored shear force,  $V_u$ , exceeds half the nominal shear strength ( $\phi V_c/2$ ), shear reinforcement must be provided. The required design shear force,  $V_u$ , at each section must not exceed the nominal design strength,  $\phi V_n$ , of the cross section based on the combined nominal shear capacity of concrete and web reinforcement:

$$V_u \leq \phi V_u \leq \phi(V_c + V_s) \quad (19.49)$$

where

- $V_c$  = nominal shear strength of concrete
- $V_s$  = nominal shear capacity of reinforcement
- $\phi$  = strength reduction factor = 0.75

When the factored shear force,  $V_u$ , is less than  $\frac{1}{2}\phi V_c$ , minimum shear reinforcement is required.

### 19.8.2 Shear Strength Provided by Concrete (Prestressed)

The ACI Code, Section 22.5.8.2, presents a simple empirical expression to estimate the nominal ultimate shear capacity of a prestressed concrete member in which the tendons have an effective prestress,  $f_{se}$ , of at least 40% of the specified tensile strength,  $f_{pu}$ :

$$V_c = \left( 0.6\lambda\sqrt{f'_c} + 700\frac{V_u d_p}{M_u} \right) b_w d \quad (19.50)$$

where

- $V_u, M_u$  = factored shear and moment at section under consideration
- $b_w$  = width of web
- $d_p$  (in term  $V_u d_p/M_u$ ) = distance from compression fibers to centroid of prestressing steel
- $d_p$  (in  $V_{ci}$  or  $V_{cw}$  equations) = larger of above  $d$  or  $0.8h$  (ACI Code, Section 22.5.2.1)

The use of Eq. 19.50 is limited to the following conditions:

1. The quantity  $V_u d_p/M_u \leq 1.0$  (to account for small values of  $V_u$  and  $M_u$ ).
2.  $V_c \geq (2\lambda\sqrt{f'_c})b_w d_p$  (minimum  $V_c$ ).
3.  $V_c \leq (5\lambda\sqrt{f'_c})b_w d_p$  (maximum  $V_c$ ).

The variation of the concrete shear capacity for a simply supported prestressed concrete beam subjected to a uniform load is shown in Fig. 19.8. Note that the maximum shear reinforcement may be required near the supports and near one-fourth of the span where  $\phi V_s$  reaches maximum values. In contrast, similar reinforced concrete beams require maximum shear reinforcement (or minimum spacing) only near the support where maximum  $\phi V_s$  develops.

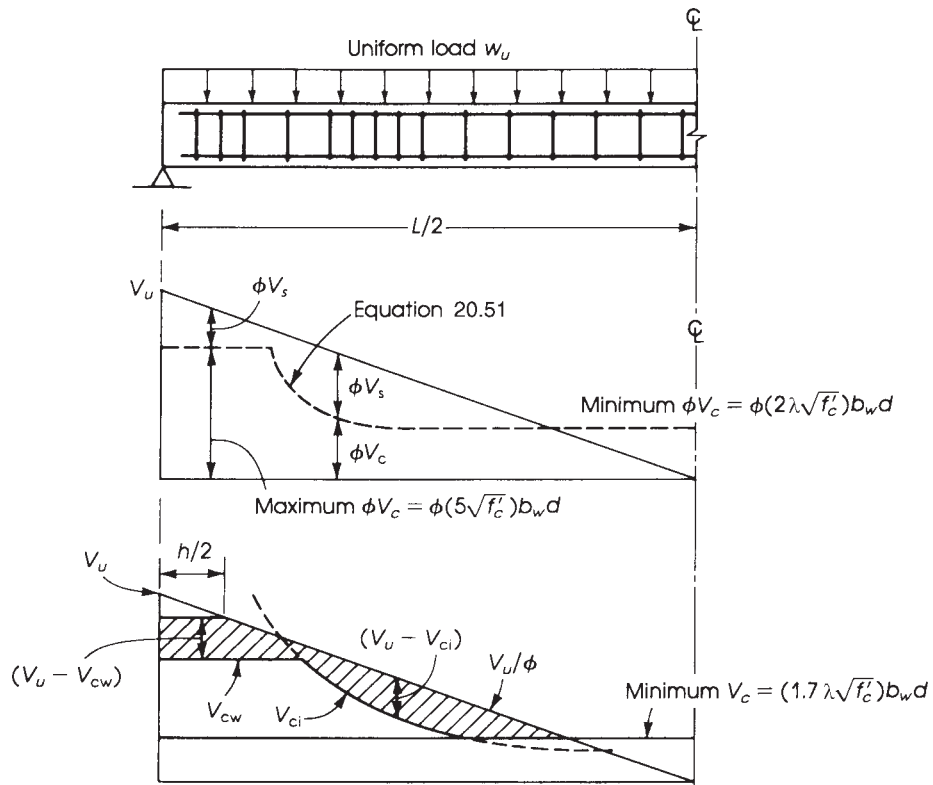
The values of  $V_c$  calculated by Eq. 19.50 may be conservative sometimes; therefore, the ACI Code, Section 22.5.8.3, gives an alternative approach for calculating  $V_c$  that takes into consideration the additional strength of concrete in the section. In this approach,  $V_c$  is taken as the smaller of two calculated values of the concrete shear strength  $V_{ci}$  and  $V_{cw}$  (Fig. 19.8). Both are explained next.

The shear strength,  $V_{ci}$ , is based on the assumption that flexural-shear cracking occurs near the interior extremity of a flexural crack at an approximate distance of  $d/2$  from the load point in the direction of decreasing moment. The ACI Code, Section 22.5.8.3.1, specifies that  $V_{ci}$  be computed as follows:

$$V_{ci} = (0.6\lambda\sqrt{f'_c})b_w d_p + V_d + \frac{V_i M_{cr}}{M_{max}} \quad (19.51)$$

but it is not less than  $(1.7\lambda\sqrt{f'_c})b_w d$ , where

- $V_d$  = shear force at section due to unfactored dead load
- $V_i$  = factored shear force at section due to externally applied loads occurring simultaneously with  $M_{max}$
- $M_{max}$  = maximum factored moment at section due to externally applied loads
- $M_{cre}$  = moment causing flexural cracking at section due to externally applied load



**Figure 19.8** Distribution of shear forces along span. The middle diagram shows shear capacity of a simply supported prestressed concrete beam. The bottom diagram shows ACI analysis. (Stirrups are required for shaded areas.)

The cracking moment can be determined from the following expression ACI Code, Section 22.5.8.3.1:

$$M_{\text{cre}} = \frac{I}{y_t} (6\lambda\sqrt{f'_c} + f_{\text{pe}} - f_d) \quad (19.52)$$

where

$I$  = moment of inertia of section resisting external factored loads

$y_t$  = distance from centroidal axis of gross section neglecting reinforcement to extreme fiber in tension

$f_{\text{pe}}$  = compressive strength at extreme fibers of concrete section due to effective prestress force after all losses

$f_d$  = stress due to unfactored dead load at extreme fiber, where tensile stress is caused by external loads

$\lambda$  = modification factor for concrete

The web-shear strength,  $V_{\text{cw}}$ , is based on shear cracking in a beam that has not cracked by flexure. Such cracks develop near the supports of beams with narrow webs. The ACI Code, Section 22.5.8.3, specifies that  $V_{\text{cw}}$  be computed as follows:

$$V_{\text{cw}} = (3.5\lambda\sqrt{f'_c} + 0.3f_{\text{pc}})b_w d_p + V_p \quad (19.53)$$

where

$V_p$  = vertical component of effective prestress force at section considered  
 $f_{pc}$  = compressive stress (psi) in concrete (after allowance for prestress losses) at centroid of section resisting applied loads or at junction of web and flange when centroid lies within flange

Alternatively,  $V_{cw}$  may be determined as the shear force that produces a principal tensile stress of  $4\lambda\sqrt{f'_c}$  at the centroidal axis of the member or at the intersection of the flange and web when the centroid lies within the flange. The equation for the principal stresses may be expressed as follows:

$$f_t = 4\lambda\sqrt{f'_c} = \sqrt{v_{cw}^2 + \left(\frac{1}{2}f_{pc}\right)^2} - \frac{1}{2}f_{pc}$$

or

$$V_{cw} = f_t \left( \sqrt{\frac{1 + f_{pc}}{f_t}} \right) b_w d_p \quad (19.54)$$

where  $f_t = 4\lambda\sqrt{f'_c}$ . When applying Eqs. 19.51 and Eqs. 19.53 or 19.54, the value of  $d$  is taken as the distance between the compression fibers and the centroid of the prestressing tendons but is not less than  $0.8h$ .

The critical section for maximum shear is to be taken at  $h/2$  from the face of the support. The same shear reinforcement must be used at sections between the support and the section at  $h/2$ .

### 19.8.3 Shear Reinforcement

The value of  $V_s$  must be calculated to determine the required area of shear reinforcement.

$$V_u = \phi(V_c + V_s) \quad (\text{Eq. 19.49})$$

$$V_s = \frac{1}{\phi}(V_u - \phi V_c) \quad (\text{Eq. 19.55})$$

For vertical stirrups,

$$V_s = \frac{A_v f_y d}{s} \quad (\text{Eq. 19.56})$$

and

$$A_v = \frac{V_s s}{f_y d_p} \quad \text{or} \quad s = \frac{A_v f_y d_p}{V_s} \quad (\text{Eq. 19.57})$$

where  $A_v$  is the area of vertical stirrups and  $s$  is the spacing of stirrups. Equations for inclined stirrups are the same as those discussed in Chapter 8.

### 19.8.4 Limitations

1. Maximum spacing,  $s_{\max}$ , of the stirrups must not exceed  $0.75h$  or 24 in. If  $V_s$  exceeds  $4\sqrt{f'_c}b_w d_p$ , the maximum spacing must be reduced to half the preceding values (ACI Code, Section 9.7.6.2.2).
2. Maximum shear,  $V_s$ , must not exceed  $8\sqrt{f'_c}b_w d_p$ ; otherwise, increase the dimensions of the section (ACI Code, Section 22.5.1.2).

3. The minimum shear reinforcement,  $A_v$ , required by the ACI Code is

$$A_{v, \min} = 0.75 \sqrt{f'_c} \left( \frac{b_w s}{f_{yt}} \right) \geq \frac{50 b_w s}{f_{yt}} \quad (\text{Eq. 19.58})$$

When the effective prestress,  $f_{pe}$ , is greater than or equal to  $0.4f_{pu}$ , the minimum  $A_v$  is

$$A_{v, \min} = \frac{A_{ps}}{80} \times \frac{f_{pu}}{f_{yt}} \times \frac{s}{d_p} \times \sqrt{\frac{d_p}{b_w}} \quad (\text{Eq. 19.59})$$

The effective depth,  $d_p$ , need not be taken less than  $0.8h$ . Generally, Eq. 19.59 requires greater minimum shear reinforcement than Eq. 19.58.

### Example 19.7

For the beam of Example 19.4, determine the nominal shear strength and the necessary shear reinforcement. Check the sections at  $h/2$  and 10 ft from the end of the beam. Use  $f_y = 60$  ksi for the shear reinforcement, and a live load = 1.33 K/ft. using normal-weight concrete.

### Solution

1. For the section at  $h/2$ :

$$\frac{h}{2} = \frac{40}{2} = 20 \text{ in.} = 1.67 \text{ ft from the end}$$

2. The factored uniform load on the beam is

$$W_u = 1.2(0.388 + 0.9) + 1.6 \times 1.33 = 3.68 \text{ K/ft}$$

$$V_u \text{ at a distance } \frac{1}{2}h = 3.68(24 - 1.67) = 82.2 \text{ K}$$

Using the simplified ACI method (Eq. 19.50), determine  $M_u$  at section  $h/2$ :

$$M_u = (3.68 \times 21) \times 1.67 - 3.68 \frac{(1.67)^2}{2} = 142.4 \text{ K} \cdot \text{ft} = 1708 \text{ K} \cdot \text{in.}$$

The value of  $d_p$  at section  $h/2$  from the end (Fig. 19.6a) is

$$d_p = 33.7(\text{at midspan}) - \frac{16 - 1.67}{16} \times 14.5 = 20.7 \text{ in.}$$

$$\frac{V_u d_p}{M_u} = \frac{82.2 \times 20.7}{1708} = 0.966 \leq 1.0$$

as required by the ACI Code.

$$\begin{aligned} V_c &= \left( 0.6\lambda \sqrt{f'_c} + 700 \frac{V_u d_p}{M_u} \right) b_w d \\ &= (0.6 \times 1 \times \sqrt{5000} + 700 \times 0.966) 6 \times 20.7 = 91,800 \text{ lb} = 91.8 \text{ K} \end{aligned}$$

$$\text{Minimum } V_c = 2\lambda \sqrt{f'_c} b_w d_p = 2 \times 1 \times \sqrt{5000} \times 6 \times 20.7 = 17.6 \text{ K}$$

$$\text{Maximum } V_c = 5\lambda \sqrt{f'_c} b_w d_p = 43.9 \text{ K}$$

The maximum  $V_c$  of 43.9 K controls.

3. The alternative approach presented by the ACI Code is that  $V_c$  may be taken as the smaller value of  $V_{ci}$  and  $V_{cw}$ .
- a. Based on the flexural-shear cracking strength,

$$V_{ci} = \left(0.6\lambda\sqrt{f'_c}\right)b_w d_p + \left(V_d + \frac{V_i M_{cre}}{M_{max}}\right) \quad (\text{Eq. 19.51})$$

Calculate each item separately:

$$(0.6\lambda\sqrt{f'_c})b_w d_p = 0.6 \times 1 \times \frac{\sqrt{5000}}{1000} \times 6 \times 20.7 = 5.3 \text{ K}$$

$$V_d = \text{unfactored dead load shear} = 1.288(24 - 1.67) = 28.8 \text{ K}$$

$$M_{max} = \text{maximum factored moment at section (except for weight of beam)}$$

$$\text{Factored load} = 1.2 \times 0.9 + 1.6 \times 1.3 = 3.13 \text{ K/ft}$$

$$M_{max} = 3.13 \left[24 \times 1.67 - \frac{(1.67)^2}{2}\right] = 121 \text{ K/ft} = 1453 \text{ K} \cdot \text{in.}$$

$$V_i = 3.13(24 - 1.67) = 69.9 \text{ K}$$

$$M_{cre} = \frac{I}{y_t} (6\lambda\sqrt{f'_c} + f_{pe} - f_d)$$

$$I = 66,862 \text{ in.}^4 \quad y_t = 19.2 \text{ in.}$$

$$f_{pe} = \text{compressive stress due to prestressing force}$$

$$= \frac{F}{A} + \frac{Fey_b}{I}$$

$$= \frac{306.2}{372} + \frac{306.2(1.5)(20.8)}{66,862} = 0.966 \text{ ksi}$$

$$f_d = \text{dead load stress} = \frac{M_D y_b}{I}$$

$$M_D = (1.288) \left[24 \times 1.67 - \frac{(1.67)^2}{2}\right] = 49.8 \text{ K} \cdot \text{ft} = 598 \text{ K} \cdot \text{in.}$$

$$f_d = \frac{598 \times 20.8}{66,862} = 0.186 \text{ ksi}$$

$$M_{cre} = \frac{66,862}{19.2} [6(1.0)\sqrt{5000} + 966 - 186] = 4193 \text{ K} \cdot \text{in.}$$

Therefore,

$$V_{ci} = 5.3 + 28.8 + 69.9 \left(\frac{4193}{1453}\right) = 235.8 \text{ K}$$

$$\text{and } V_{ci} \text{ must not be less than } (1.7\lambda\sqrt{f'_c})b_w d_p = (1.7 \times 1 \times \sqrt{5000}) \times 6 \times 20.7 = 14.9 \text{ K}$$

- b. Shear strength based on web-shear cracking is

$$V_{cw} = (3.5\lambda\sqrt{f'_c} + 0.3f_{pc})b_w d_p + V_p$$

$$f_{pc} = \frac{306.2}{372} = 0.823 \text{ ksi}$$

$$d_p = 20.7 \text{ in.} \quad \text{or} \quad 0.8h = 0.8 \times 40 = 32 \text{ in.} \quad (\text{Eq. 19.53})$$



Use  $d_p = 32$  in.

$$V_p = 306.2 \times \frac{1}{13.2} = 23.2 \text{ K}$$

where  $1/13.2 =$  slope of tendon profile  $= 14.5 \text{ in.}/(16 \times 12)$ .

$$3.5\lambda\sqrt{f'_c} = 3.5 \times 1 \times \sqrt{5000} = 248 \text{ psi}$$

Therefore,

$$V_{cw} = (0.248 + 0.3 + 0.823) \times 6 \times 32 + 23.2 = 118.2 \text{ K}$$

c. Because  $V_{cw} < V_{ci}$ , the value  $V_{cw} = 118.2 \text{ K}$  represents the nominal shear strength at section  $h/2$  from the end of the beam. In most cases,  $V_{cw}$  controls at  $h/2$  from the support.

4. Web reinforcement:

$$V_u = 82.3 \text{ K} \quad \phi V_{cw} = 0.75 \times 118.2 = 88.65 \text{ K}$$

Because  $V_u < \phi V_{cw}$ ,  $V_s = 0$ ; therefore, use minimum stirrups. Use no. 3 stirrups. Reinforcement  $A_v = 2 \times 0.11 = 0.22 \text{ in.}^2$  Maximum spacing is the least of

$$s_1 = (0.75)h = (0.75) \times 40 = 30 \text{ in.} \quad s_2 = 24 \text{ in.}$$

Calculate  $s_3$  from the equation of minimum web reinforcement:

$$\begin{aligned} \text{Min. } A_v &= \frac{A_{ps}}{80} \times \frac{f_{pu}}{f_{yt}} \times \frac{s}{d_p} \times \sqrt{\frac{d_p}{b_w}} \\ 0.22 &= \frac{2.178}{80} \times \frac{250}{60} \times \frac{s_3}{20.7} \sqrt{\frac{20.7}{6}} \\ s_3 &= 21.6 \text{ in.} \quad (20 \text{ in.}) \end{aligned} \quad (\text{Eq. 19.59})$$

Also,

$$\begin{aligned} \text{Min. } A_v &= 0.75\sqrt{f'_c} \left( \frac{b_w s}{f_{yt}} \right) \geq \frac{50b_w s}{f_{yt}} \quad 0.75\sqrt{f'_c} = 53 \\ s_4 &= \frac{A_v f_y}{53b_w} = \frac{0.22 \times 60,000}{53 \times 6} = 41.5 \text{ in.} \\ s_{\max} &= s_3 = 20 \text{ in. controls} \end{aligned}$$

Thus, use no. 3 stirrups spaced at 20 in.

5. For the section at 10 ft from the end, the calculation procedure is similar to that for the section at  $h/2$ . Using the ACI simplified method,

$$V_u = 3.68(24 - 10) = 51.5 \text{ K}$$

$$M_u = 3.68 \left[ 24 \times 10 - \frac{(10)^2}{2} \right] = 699.2 \text{ K} \cdot \text{ft} = 8390 \text{ K} \cdot \text{in.}$$

$$d_p = 33.7 \text{ (at midspan)} - \frac{16 \times 10}{16} \times 14.5 = 28.3 \text{ in.}$$

$$\frac{V_u d_p}{M_u} = \frac{51.5 \times 28.3}{8390} = 0.174 < 1.0$$

$$V_c = (0.6 \times 1 \times \sqrt{5000} + 0.174 \times 700)6 \times 28.3 = 27,886 \text{ lb} = 27.9 \text{ K} \quad (\text{controls})$$

Minimum  $V_c = 17.6 \text{ K}$  Maximum  $V_c = 43.9 \text{ K}$

6. Using the ACI Code equations to compute  $V_{ci}$  and  $V_{cw}$ , calculate  $V_{ci}$  first (which controls at this section):

$$0.6\lambda\sqrt{f'_c}b_wd_p = 0.6 \times 1 \times \sqrt{5000} \times 6 \times 28.3 = 7.2 \text{ K}$$

$$V_d = 1.288(24 - 10) = 18 \text{ K}$$

$$M_{\max} = 3.13 \left[ 24 \times 10 - \frac{(10)^2}{2} \right] = 594.7 \text{ K} \cdot \text{ft} = 7136 \text{ K} \cdot \text{in.}$$

$$V_i = 3.13(24 - 10) = 43.8 \text{ K}$$

$$f_{pe} = \frac{306.2}{372} + \frac{306.2(9.1)(20.8)}{66,862} = 1.69 \text{ ksi}$$

$$M_D = 1.288 \left[ 24 \times 10 - \frac{(10)^2}{2} \right] = 244.7 \text{ K} \cdot \text{ft} = 2937 \text{ K} \cdot \text{in.}$$

$$f_d = \frac{2937 \times 20.8}{66,862} = 0.914 \text{ ksi} \quad M_{cr} = 4193 \text{ K} \cdot \text{in.}$$

Therefore,

$$V_{ci} = 7.2 + 18 + \frac{43.8(4193)}{7136} = 50.9 \text{ K}$$

$$V_{ci, \min} = (1.7 \times 1 \times \sqrt{5000})6 \times 28.3 = 20.4 \text{ K}$$

Thus the minimum is met. Then calculate  $V_{cw}$ :

$$f_{pc} = 0.893 \text{ ksi} \quad V_p = 23.2 \text{ K} \quad (\text{as before})$$

$$d_p = 28.3 \text{ in.} \quad \text{or} \quad 0.8h = 32 \text{ in.}$$

Use  $d_p = 32 \text{ in.}$

$$\begin{aligned} V_{cw} &= (3.5\lambda\sqrt{f'_c} + 0.3f_{pc})b_wd_p + V_p \\ &= (0.248 + 0.3 \times 0.823)6 \times 32 + 23.2 = 118.2 \text{ K} \end{aligned}$$

This value of  $V_{cw}$  is not critical. At about span/4, the critical shear value is  $V_{ci}$  (Fig. 19.8).

7. To calculate web reinforcement,

$$V_u = 51.5 \text{ K} \quad \phi V_{ci} = 0.75 \times 50.9 = 38.2 \text{ K}$$

$$V_u = \phi(V_c + V_s)$$

$$V_s = \frac{1}{0.75}(51.5 - 38.2) = 17.7 \text{ K}$$

Use no. 3 stirrups;  $A_v = 0.22 \text{ in}^2$ . Check maximum spacing:  $s_{\max} = 18 \text{ in.}$  (as before).

$$\text{Required } A_v = \frac{V_s s}{f_y d_p} = \frac{17.7 \times 18}{60 \times 28.3} = 0.187 \text{ in}^2$$

The value of  $A_v$  used is  $0.22 \text{ in}^2 > 0.187 \text{ in}^2$ . Therefore, use no. 3 stirrups spaced at 14 in.

## 19.9 PRELIMINARY DESIGN OF PRESTRESSED CONCRETE FLEXURAL MEMBERS

### 19.9.1 Shapes and Dimensions

The detailed design of prestressed concrete members often involves a considerable amount of computation. A good guess at the dimensions of the section can result in a savings of time and effort. Hence it is important to ensure, by preliminary design, that the dimensions are reasonable before starting the detailed design.

At the preliminary design stage, some data are usually available to help choose proper dimensions. For example, the bending moments due to the applied external loads, the permissible stresses, and the data for assessing the losses are already known or calculated.

The shape of the cross section of a prestressed concrete member may be a rectangular, T-, I-, or box section. The total depth of the section,  $h$ , may be limited by headroom considerations or may not be specified. Given the freedom of selection, an empirical practical choice of dimensions for a preliminary design is as follows (Fig. 19.9):

1. Total depth of section is  $h = \frac{1}{20}$  to  $\frac{1}{30}$  of the span  $L$ ; for heavy loading  $h = L/20$  and for light loading  $h = L/30$  or  $h = 2\sqrt{M_D + M_L}$ , where  $M$  is in K·ft.
2. The depth of top flange is  $h_f = h/8$  to  $h/6$ .
3. The width of top flange is  $b \geq 2h/5$ .
4. The thickness of the web is  $b_w \geq 4$  in. Usually  $b_w$  is taken as  $h/30 + 4$  in.
5. The values of  $b_w$  and  $t$  are chosen to accommodate and uniformly distribute the prestressing tendons, keeping appropriate concrete cover protection.
6. The approximate area of the concrete section required is

$$A_c \text{ (ft}^2\text{)} = \frac{M_D + M_L}{30h}$$

where  $M_D + M_L$  are in K·ft and  $h$  is in ft. In SI units,

$$A_c \text{ (m}^2\text{)} = \frac{M_D + M_L}{1450h} \quad (M_D + M_L \text{ in kN} \cdot \text{m and } h \text{ in m})$$

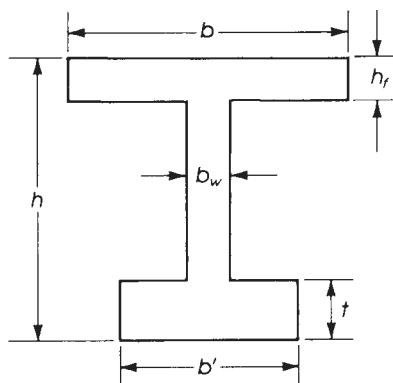
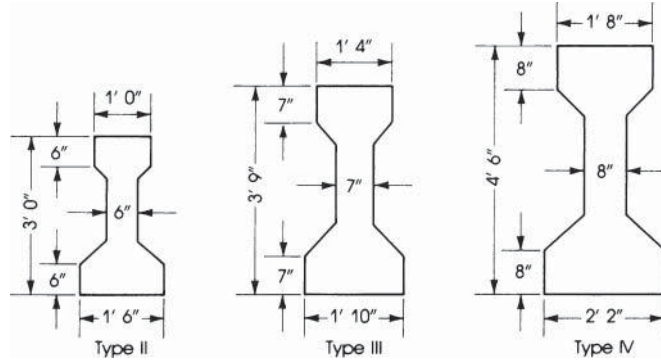


Figure 19.9 Proportioning prestressed concrete sections.

**Table 19.4** AASHTO Girders, Normal-Weight Concrete 25

Designation	A (in. <sup>2</sup> )	I (in. <sup>4</sup> )	y <sub>b</sub> (in.)	Z <sub>b</sub> (in. <sup>3</sup> )	Z <sub>t</sub> (in. <sup>3</sup> )	Weight (lb/ft)
Type II	369	50,979	15.83	3220	2527	384
Type III	560	125,390	20.27	6186	5070	593
Type IV	789	260,741	24.73	10,544	8908	822



For practical and economical design of prestressed concrete beams and floor slabs, the precast concrete industry has introduced a large number of standardized shapes and dimensions from which the designer can choose an adequate member. Tables of standard sections are available in the *PCI Design Handbook* [3]. AASHTO [23] has also presented standard girders to be used in bridge construction (Table 19.4).

### 19.9.2 Prestressing Force and Steel Area

Once the shape, depth, and other dimensions of the cross section have been selected, approximate values of the prestressing force and the area of the prestressing steel,  $A_{ps}$ , can be determined.

From the internal couple concept, the total moment,  $M_T$ , due to the service dead and live loads is equal to the tension force,  $T$ , times the moment arm,  $jd$ :

$$M_T = T(jd) = C(jd)$$

$$M_T = A_{ps}f_{se}(jd) \quad A_{ps} = \frac{M_T}{f_{se}(jd)}$$

where  $A_{ps}$  is the area of the prestressing steel and  $f_{se}$  is the effective prestressing stress after all losses. The value of the moment arm,  $jd$ , varies from  $0.4h$  to  $0.8h$ , with a practical range of  $0.6h$  to  $0.7h$ . An average value of  $0.65$  may be used. Therefore,

$$A_{ps} = \frac{M_T}{(0.65h)f_{se}} \quad (19.60)$$

and the prestressing force is

$$F = T = A_{ps}f_{se} = \frac{M_T}{0.65h} \quad (19.61)$$

The prestressing force at transfer is  $F_i = F/\eta$ , where  $\eta$  is the factor of time-dependent losses.

The compressive force,  $C$ , on the section is equal to the tension force,  $T$ :

$$C = T = A_{ps}f_{se}$$

In terms of stresses,

$$\frac{C}{A_c} = \frac{A_{ps}f_{se}}{A_c} = f_{c_1}$$

where  $f_{c_1}$  is an assumed uniform stress on the section.

For a preliminary design, a triangular stress distribution is assumed with maximum allowable compressive stress,  $f_{ca}$ , on one extreme fiber; therefore, the average stress is  $0.5f_{ca} = f_{c_1}$ . The allowable compressive stress in concrete is  $f_{ca} = 0.45f'_c$ . Thus, the required concrete area,  $A_c$ , can be estimated from the force,  $T$ , as follows:

$$A_c = \frac{T}{f_{c_1}} = \frac{A_{ps}f_{se}}{f_{c_1}} = \frac{A_{ps}f_{se}}{0.5f_{ca}} = \frac{A_{ps}f_{se}}{0.225f'_c} \quad (19.62)$$

$$A_c = \frac{T}{0.5f_{ca}} = \frac{M_T}{(0.65h)(0.5f_{ca})} = \frac{M_T}{0.33f_{ca}} = \frac{M_T}{0.15f'_c} \quad (19.63)$$

This analysis is based on the design for service loads and not for the factored loads. The eccentricity,  $e$ , is measured from the centroid of the section to the centroid of the prestressing steel and can be estimated approximately as follows:

$$e = K_b + \frac{M_D}{F_i} \quad (19.64)$$

where  $K_b$  is the lower Kern limit and  $M_D$  is the moment due to the service dead load.

## 19.10 END-BLOCK STRESSES

### 19.10.1 Pretensioned Members

Much as a specific development length is required in every bar of a reinforced concrete beam, the prestressing force in a prestressed concrete beam must be transferred to the concrete by embedment or end anchorage or a combination thereof. In pretensioned members, the distance over which the effective prestressing force is transferred to the concrete is called the transfer length,  $l_t$ . After transfer, the stress in the tendons at the extreme end of the member is equal to 0, whereas the stress at a distance  $l_t$  from the end is equal to the effective prestress,  $f_{pe}$ . The transfer length,  $l_t$ , depends on the size and type of the tendon, surface condition, concrete strength,  $f'_c$ , stress, and method of force transfer. A practical estimation of  $l_t$  ranges between 50 and 100 times the tendon diameter. For strands, a practical value of  $l_t$  is equal to 50 tendon diameters, whereas for single wires,  $l_t$  is equal to 100 wire diameters.

In order that the tension in the prestressing steel develop full ultimate flexural strength, a bond length is required. The purpose is to prevent general slip before the failure of the beam at its full design strength. The development length,  $l_d$ , is equal to the bond length plus the transfer length,  $l_t$ . Based on established tests, the ACI Code, Section 25.4.8, gives the following expression for computing the development length of seven-wire pretensioning strands:

$$l_d \text{ (in.)} = \left( \frac{f_{se}}{3000} \right) d_b - \left( \frac{f_{ps} - f_{se}}{1000} \right) d_b \quad (19.65)$$

where

$$\begin{aligned} f_{ps} &= \text{stresses in prestressed reinforcement at nominal strength (psi)} \\ f_{se} &= \text{effective stress in prestressed reinforcement after all losses (psi)} \\ d_b &= \text{nominal diameter of wire or strand (in.)} \end{aligned}$$

If bonding of the strand does not extend to end of members, and design includes tension at service loads in the precompressed tension zone  $l_d$  calculated by equation 19.65 shall be doubled.

In pretensioned members, high tensile stresses exist at the end zones, for which special reinforcement must be provided. Such reinforcement in the form of vertical stirrups is uniformly distributed within a distance  $h/5$  measured from the end of the beam. The first stirrup is usually placed at 1 to 3 in. from the beam end or as close as possible. It is a common practice to add nominal reinforcement for a distance  $d$  measured from the end of the beam. The area of the vertical stirrups,  $A_v$ , to be used at the end zone can be calculated approximately from the following expression:

$$A_v = 0.021 \frac{F_i h}{f_{se} l_t} \quad (19.66)$$

where  $f_{se}$  is allowable stress in the stirrups (usually 20 ksi) and  $l_t$  is equal to 50 tendon diameters.

### Example 19.8

Determine the necessary stirrup reinforcement required at the end zone of the beam given in Example 19.4.

#### Solution

$$F_i = 365.9 \text{ K} \quad h = 40 \text{ in.} \quad f_s = 20 \text{ ksi} \quad l_t = 50 \times \frac{7}{16} = 22 \text{ in.}$$

Therefore,

$$A_v = 0.021 \times \frac{365.9 \times 40}{20 \times 22} = 0.7 \text{ in.}^2$$

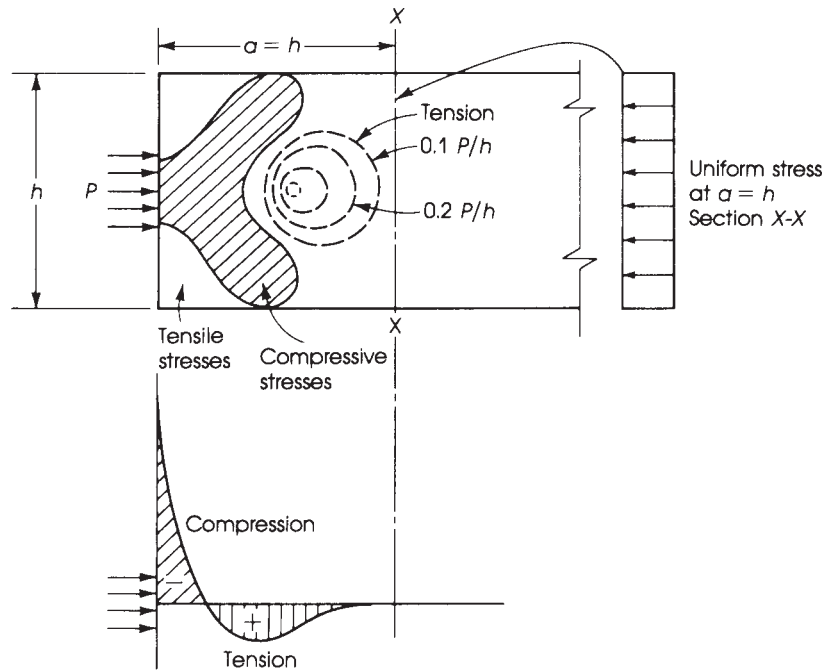
$$\frac{h}{2} = \frac{40}{5} = 8 \text{ in.}$$

Use four no. 3 closed stirrups within the first 8 in. distance from the support;  $A_v$  (provided) =  $4 \times 0.22 = 0.88 \text{ in.}^2$ .

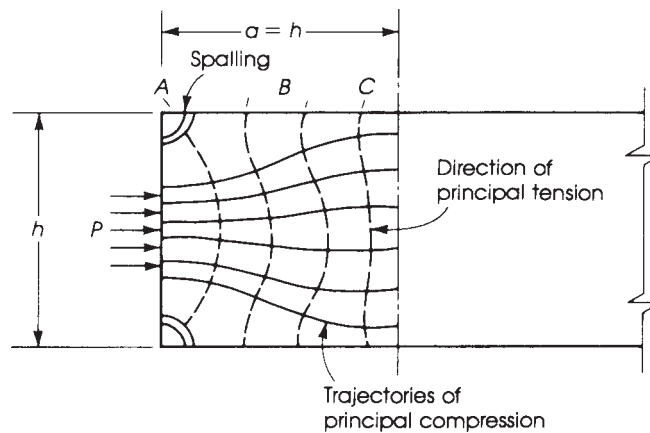
## 19.10.2 Posttensioned Members

In posttensioned concrete members, the prestressing force is transferred from the tendons to the concrete, for both bonded and unbonded tendons, at the ends of the member by special anchorage devices. Within an anchorage zone at the end of the member, very high compressive stresses and transverse tensile stresses develop, as shown in Fig. 19.10. In practice, it is found that the length of the anchorage zone does not exceed the depth of the end of the member; nevertheless, the state of stress within this zone is extremely complex.

The stress distribution due to one tendon within the anchorage zone is shown in Fig. 19.11. At a distance  $h$  from the end section, the stress distribution is assumed uniform all over the section. Considering the lines of force (trajectories) as individual elements acting as curved struts, the trajectories tend to deflect laterally toward the centerline of the beam in zone *A*, inducing compressive stresses. In zone *B*, the curvature is reversed in direction and the struts deflect outward, inducing tensile stresses. In zone *C*, struts are approximately straight, inducing uniform stress distribution.



**Figure 19.10** Tension and compression zones in a posttensioned member.



**Figure 19.11** Tension and compression trajectories in a posttensioned member.

The reinforcement required for the end anchorage zones of posttensioned members generally consists of a closely spaced grid of vertical and horizontal bars throughout the length of the end block to resist the bursting and tensile stresses. It is a common practice to space the bars not more than 3 in. in each direction and to place the bars not more than 1.5 in. from the inside face of the bearing plate. Approximate design methods are presented in Refs. 24 to 27.

## SUMMARY

### Section 19.1

The main objective of prestressing is to offset or counteract all or most of the tensile stresses in a structural member produced by external loadings, thus giving some advantages over a reinforced concrete member. A concrete member may be pretensioned or posttensioned. Nonprestressed reinforcement may also be added to the concrete member to increase its ultimate strength.

### Section 19.2

1. The allowable stresses in concrete at transfer are

$$\text{Maximum compressive stress} = 0.6f'_{ci}$$

$$\text{Maximum compressive stress at end of simply supported beam} = 0.7f'_{ci}$$

$$\text{Maximum tensile stress} = 3\sqrt{f'_{ci}}$$

$$\text{Maximum tensile stress at end of simply supported beam} = 6\sqrt{f'_{ci}}$$

The allowable stresses after all losses are  $0.45f'_c$  for compression and  $6f'_c$  for tension.

2. The allowable stress in a pretensioned tendon at transfer is the smaller of  $0.74f_{pu}$  or  $0.82f_{py}$ . The maximum stress due to the tendon jacking force must not exceed  $0.85f_{pu}$  or  $0.94f_{py}$ ; and the maximum stress in a posttensioned tendon after the tendon is anchored is  $0.70f_{pu}$ .

### Section 19.3

The sources of prestress loss are the elastic shortening, shrinkage, and creep of concrete; relaxation of steel tendons; and friction. An approximate lump-sum loss is 35 ksi for pretensioned members and 25 ksi for posttensioned members (friction is not included).

$$\text{Loss due to elastic shortening} = \frac{nF_i}{A_c} \quad (\text{Eq. 19.1})$$

$$\text{Loss due to shrinkage} = \epsilon_{sh}E_s \quad (\text{Eq. 19.6})$$

$$\text{Loss due to creep} = C_c(\epsilon_c E_s) \quad (\text{Eq. 19.7})$$

Loss due to relaxation of steel varies between 2.5 and 12%. Loss due to friction in posttensioned members stems from the curvature and wobbling of the tendon.

$$P_{px} = \begin{cases} P_{pj}e^{-(kl_{px} + \mu_p \alpha_{px})} & (\text{Eq. 19.10}) \\ P_{pj}(1 + Kl_{px} + \mu_p \alpha_{px})^{-1} & (\text{Eq. 19.11}) \end{cases}$$

### Section 19.4

Elastic stresses in a flexural member due to loaded and unloaded conditions are given by Eqs. 19.13 through 19.16. The limiting values of the eccentricity,  $e$ , are given by Eqs. 19.20, 19.22, 19.24, and 19.26. The minimum and maximum values of  $F_i$  are given by Eqs. 19.31 and Eqs. 19.32, respectively.



### Section 19.5

The nominal moment of a rectangular prestressed concrete member is

$$M_n = T \left( d - \frac{a}{2} \right) = A_{ps} f_{ps} d_p \left( 1 - \frac{\rho_p f_{ps}}{1.7 f'_c} \right) \quad (\text{Eq. 19.37})$$

The values of  $f_{ps}$  are given by Eqs. 19.39 to 19.41. For flanged sections,

$$M_n = A_{pw} f_{ps} \left( d_p - \frac{a}{2} \right) + A_{pf} f_{ps} \left( d_p - \frac{h_f}{2} \right) \quad (\text{Eq. 19.43})$$

If nonprestressed reinforcement is used in the flexural member, then

$$M_n = A_{ps} f_{ps} \left( d_p - \frac{a}{2} \right) + A_s f_y \left( d - \frac{a}{2} \right) \quad (\text{Eq. 19.44})$$

where  $a = (A_{ps} f_{ps} + A_s f_y) / 0.85 f'_c b$ . For  $M_n$  of flanged and rectangular sections with compression reinforcement, refer to Eqs. 19.46 and Eqs. 19.47, respectively.

### Sections 19.6 and 19.7

1. The cracking moment is

$$M_{cr} = \frac{I}{y_b} \left[ 7.5 \lambda \sqrt{f'_c} + \frac{F}{A} + \frac{(Fe) y_b}{I} \right] \quad (\text{Eq. 19.48})$$

2. Midspan deflections of simply supported beams are summarized in Table 19.3.

### Section 19.8

$$\text{Shear strength of concrete } (V_c) = \left( 0.6 \lambda \sqrt{f'_c} + 700 \frac{V_u d_p}{M_u} \right) b_w d \quad (\text{Eq. 19.50})$$

$$\text{Minimum } V_c = 2 \lambda \sqrt{f'_c} b_w d_p$$

$$\text{Maximum } V_c = 5 \lambda \sqrt{f'_c} b_w d_p$$

The shear strength,  $V_{ci}$ , based on flexural shear, is given by Eq. 19.47, and the web-shear strength,  $V_{cw}$ , is given by Eq. 19.53:

$$V_s = \frac{1}{\phi} (V_u - \phi V_c) \quad \text{and} \quad A_v = \frac{A_{ps}}{80} \times \frac{f_{pu}}{f_y} \times \frac{S}{d} \times \sqrt{\frac{d}{b_w}} \quad (\text{Eq. 19.59})$$

### Section 19.9

Empirical practical dimensions for the preliminary design of prestressed concrete members are suggested in this section.

### Section 19.10

The development length of three- to seven-wire strands is

$$l_d = \left( f_{ps} - \frac{2}{3} f_{se} \right) d_b \quad (\text{Eq. 19.65})$$

The area of stirrups in an end block is

$$A_v = 0.021 \frac{F_t h}{f_{se} l_t} \quad (\text{Eq. 19.66})$$

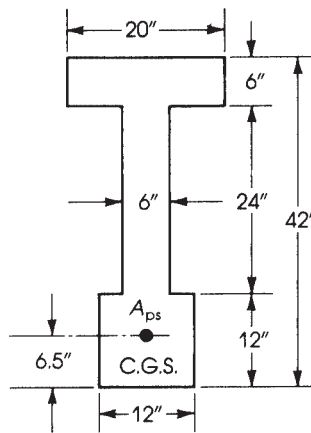
## REFERENCES

1. American Concrete Institute (ACI). “*Building Code Requirements for Structural Concrete.*” ACI 318-14. ACI, Detroit, MI, 2014.
2. P. W. Abeles. “Design of Partially Prestressed Concrete Beams.” *ACI Journal* 64 (October 1967).
3. Prestressed Concrete Institute (PCI). *PCI Design Handbook*, 7th ed. PCI, Chicago, IL, 2010.
4. E. Freyssinet. “A Revolution in the Technique of Utilization of Concrete.” *Structural Engineer* 14 (May 1936).
5. H. Straub. *History of Civil Engineering*. Leonard Hill, London, 1952.
6. P. W. Abeles and L. Dziprynski. “Partial Prestressing, Its History, Research, Application and Future Development.” Convention on Partial Prestressing, Brussels (October 1965). *Annales des Travaux Publics de Belgique* 2 (April 1966).
7. P. W. Abeles. “Fully and Partly Prestressed Reinforced Concrete.” *ACI Journal* 41 (January 1945).
8. F. Leonhardt. *Prestressed Concrete Design and Construction*. Wilhelm Ernest and Son, Berlin, 1964.
9. P. W. Abeles. *Introduction to Prestressed Concrete*, vols. I and II. Concrete Publications, London, 1966.
10. “The Death of Mr. Freyssinet.” *S.T.U.P. Gazette*, 11, (1962).
11. P. W. Abeles. “Partial Prestressing and Its Possibilities for Its Practical Application.” *PCI Journal* 4, no. 1 (June 1959).
12. W. H. Hewett. “A New Method of Constructing Reinforced Concrete Tanks.” *ACI Journal* 19 (1932).
13. R. E. Dill. “Some Experience with Prestressed Steel in Small Concrete Units.” *ACI Journal* 38 (November 1941).
14. F. W. Dodge. *The Structures of Eduardo Torroja*. McGraw-Hill, New York, 1959.
15. E. Freyssinet. “The Birth of Prestressing.” Cement and Concrete Association Translation, no. 59, London, 1956.
16. G. Mangel. *Prestressed Concrete*. Concrete Publications, London, 1954.
17. W. Zerna. “Partially Prestressed Concrete” (in German). *Beton Stahlbeton*, no. 12 (1956).
18. R. H. Evans. “Research and Development in Prestressing.” *Journal of the Institution of Civil Engineers* 35 (February 1951).
19. E. Freyssinet. “Prestressed Concrete, Principles and Applications.” *Journal of the Institution of Civil Engineers* 4 (February 1950).
20. P. J. Verna. “Economics of Prestressed Concrete in Relation to Regulations, Safety, Partial Prestressing ... in the U.S.A.” Paper presented at the Fourth Congress of the FIP, Rome-Naples, Theme III, Paper 1, 1962.
21. S. Chaikes. “The Reinforced Prestressed Concrete.” Paper presented at the Fourth Congress of the FIP, Rome-Naples, Theme III, Paper 2, 1962.
22. ACI Committee 435. “Deflection of Prestressed Concrete Members.” *ACI Journal* 60 (December 1963).
23. American Association of State and Highway Transportation officials (AASHTO). *LRFD Bridge Design Specifications*, 7th ed. AASHTO, Washington, DC, 2014.
24. Posttensioning Institute (PI). *Posttensioning Manual*. PI, Phoenix, AZ, 1976.
25. Prestressed Concrete Institute (PCI). *PCI Design Handbook*. PCI, Chicago, IL, 1999.
26. P. Gergley and M. A. Sozen. “Design of Anchorage Zone Reinforcement in Prestressed Concrete Beams.” *PCI Journal* 12 (April 1967).

27. Y. Guyon. *Prestressed Concrete*. Wiley, New York, 1960.
28. P. Zia, H. K. Peterson, N. L. Scott, and E. B. Workman. "Estimating Prestress Losses." *Concrete International* 1 (June 1979).

## PROBLEMS

- 19.1 A 60-ft-span of a simply supported pretensioned beam has the section shown in Fig. 19.12. The beam is prestressed by a force  $F_i = 395$  K at transfer (after the elastic loss). The prestress force after all losses is  $F = 320$ ,  $f'_c$  (compressive stress after all losses) = 6 ksi and  $f'_{ci} = 4$  ksi. For the midspan section and using the ACI Code allowable stresses, (a) calculate the extreme fiber stresses due to the prestressing force plus dead load and (b) calculate the allowable uniform live load on the beam.



**Figure 19.12** Problem 19.1.

- 19.2 For the beam of Problem 19.1 (Fig. 19.12), calculate the elastic loss and all time-dependent losses using the following data:  $F_i = 405$  K,  $A_{ps} = 2.39$  in.<sup>2</sup> located at 6.5 in. from the base,  $f'_c = 4$  ksi, and  $f'_c = 6$  ksi.  $E_c = 57,000\sqrt{f'_c}$ , and  $E_s = 28,000$  ksi. The profile of the tendon is parabolic, and the eccentricity at the supports is 0.
- 19.3 The cross section of a 56-ft-span simply supported posttensioned girder that is prestressed by 30 cables  $\frac{7}{16}$  in. diameter (area of one cable is 0.1089) is shown in Fig. 19.13. The cables are made of seven-wire stress-relieved strands. The profile of the cables is parabolic with the centroid of the prestressing steel (CGS) located at 9.6 in. from the base at the midspan section and located at the centroid of the concrete section ( $e = 0$ ) at the ends. Calculate the elastic loss of prestress and all other losses. Given:  $f'_c = 6$  ksi,  $f'_{ci} = 4$  ksi,  $E_c = 57,000\sqrt{f'_c}$ ,  $E_s = 28,000$  ksi,  $f_{pu} = 250$  ksi,  $F_0 = 175$  ksi, DL = 1.0 K/ft (excluding self-weight), and LL = 1.6 K/ft.
- 19.4 For the girder of Problem 19.3,
- Determine the location of the upper and lower limits of the tendon profile for the section at midspan and for at least two other sections between midspan and support. (Choose sections at 12, 18, and 25 ft from support.)
  - Check if the parabolic profile satisfies these limits.
- 19.5 For the girder of Problem 19.3, check the limiting values of the prestressing force at transfer  $F_i$ .

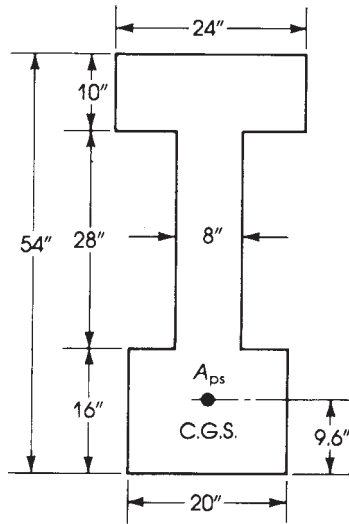


Figure 19.13 Problem 19.3.

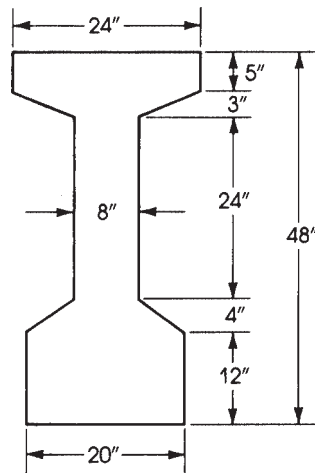
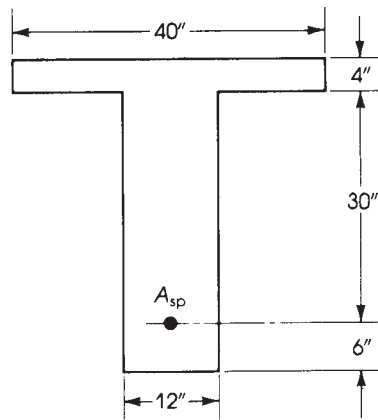


Figure 19.14 Problem 19.6.

- 19.6** A 64-span simply supported pretensioned girder has the section shown in Fig. 19.14. The loads on the girder consist of a dead load = 1.2 K/ft (excluding its own weight) that will be applied at a later stage and a live load of 0.6 K/ft. The prestressing steel consists of 24 cables  $\frac{1}{2}$  in. in diameter (area of one cable = 0.114 in.<sup>2</sup>), with  $E_s = 28,000$  ksi,  $F_0 = 175$  ksi, and  $f_{pu} = 250$  ksi. The strands are made of seven-wire stress-relieved steel. The concrete compressive strength at transfer is  $f'_{ci} = 4$  ksi, and at 28 days,  $f'_c = 5$  ksi. The modulus of elasticity is  $E_c = 57,000\sqrt{f'_c}$ . For the beam just described,
- Determine the upper and lower limits of the tendon profile for the section at midspan and three other sections between the midspan section and the support. (Choose sections at 3, 11, and 22 ft from the support.)

- b. Locate the tendons to satisfy these limits using straight horizontal tendons within the middle third of the span.
  - c. Check the limiting values of the prestressing force at transfer.
- 19.7** For the girder of Problem 19.6:
- a. Harp some of the tendons at one-third points, and draw sections at midspan and at the end of the beam showing the distribution of tendons.
  - b. Revise the prestress losses, taking into consideration the variation of the eccentricity,  $e$ , along the beam.
  - c. Check the factored moment capacity of the section at midspan.
  - d. Determine the cracking moment.
- 19.8** For the girder of Problem 19.6:
- a. Calculate the camber at transfer.
  - b. Calculate the immediate deflection at service load.
- 19.9** For the girder of Problem 19.6, determine the shear capacity of the section and calculate the necessary web reinforcement.
- 19.10** Determine the nominal moment capacity,  $M_n$ , of a pretensioned concrete beam that has the cross section shown in Fig. 19.15. Given:  $f'_c = 5$  ksi,  $f_{pu} = 270$  psi,  $f_{se} = 160$  ksi, and  $A_{se} = 2.88$  in<sup>2</sup>.



**Figure 19.15** Problem 19.10.

# CHAPTER 20

## SEISMIC DESIGN OF REINFORCED CONCRETE STRUCTURES



Collapse of frame concrete structures due to an earthquake. Courtesy of Murat Saatcioglu and John Gardner.

### 20.1 INTRODUCTION

Ground motions during an earthquake can severely damage the structure. The ground acceleration when transmitted through the structure is amplified, and it is called the response acceleration. The amplified motion can produce forces and displacements that can be larger than the motions the structure can sustain.

Many factors influence the intensity of shaking of the structure such as earthquake magnitude, distance from fault or epicenter, duration of strong shaking, soil conditions of the site, and frequency content of the motion.

A structure should be designed, depending on the type of structure and its function, to have acceptable levels of response generated in an earthquake. Economy of design is achieved by allowing the structure to deform above elastic limit.

### 20.2 SEISMIC DESIGN CATEGORY

*Building Code Requirements for Structural Concrete* (ACI 318) [1] gives the procedure for design and detailing of structures subjected to earthquake loads but does not address the calculations of seismic forces. In this chapter the International Building Code (IBC 2012) [2] will be utilized for the calculation of seismic forces.

The IBC 2012, Section 1613, defines six seismic design categories (SDC): A, B, C, D, E, and F. IBC 2012, Section 1613.3.5, also defines four risk categories: I, II, III, and IV. To relate the SDC and the risk category, the design spectral response acceleration  $S_{DS}$  and  $S_{D1}$  are used.  $S_{DS}$  is the design spectral response acceleration coefficient for short periods and  $S_{D1}$  is the design response acceleration coefficient for a 1-second period. Design spectral response acceleration coefficients are related to severity of the design earthquake ground motions at the site.

A seismic design category will determine which type of lateral force analysis must be performed and which type of lateral force resisting system must be used.

### 20.2.1 Determination of Risk Category and Site Class Definition

Buildings shall be assigned a risk category according to Table 20.1 as described in IBC 2012, Section 1604.5. The first step is to define the nature of occupancy of the structure according to the risk category. The seismic importance factor,  $I_e$ , by risk category is also listed in Table 20.1 and will be utilized in a later section.

Based on the site soil properties, the site shall be classified as either site class A, B, C, D, E, and F in accordance with Table 20.4 below. When the soil properties are not known in sufficient detail to determine site class, site class D shall be used.

### 20.2.2 Determination of Design Spectral Response Acceleration Coefficients

Earthquake ground motion is usually recorded as an acceleration of the ground at a particular location. The acceleration of the ground generates the acceleration of the structure (response acceleration), which produces earthquake forces that act on the structure. Earthquake forces generate deformations, internal forces, and stresses in the structure. If the structure is not properly designed to sustained deformations and forces, it will have great damage and may even collapse.

Therefore, the first step to design an earthquake-resistant structure is to determine the maximum possible response accelerations that can occur during the earthquake. It is also important to know that response of the given structure depends on period of vibration and damping characteristics of the structure.

The IBC 2012, Section 1613.3.4, gives a procedure to determine the design response spectrum curve, from which the design response accelerations,  $S_a$ , for any given period of vibration,  $T$  are calculated. One part of this procedure is the determination of the design spectral response acceleration coefficients for short periods,  $S_{DS}$ , and for a 1-second period,  $S_{D1}$ .

To calculate the design acceleration values for short periods,  $S_{DS}$ , and 1-second periods,  $S_{D1}$ , the following equation can be utilized:

$$S_{DS} = \frac{2}{3}S_{MS} \quad (20.1a)$$

$$S_{D1} = \frac{2}{3}S_{M1} \quad (20.1b)$$

where

$S_{MS}$  = mapped maximum considered earthquake spectral response accelerations for short periods adjusted for site class effect

$S_{M1}$  = mapped maximum considered earthquake spectral response accelerations for 1-s period adjusted for site class effect

Thus,  $S_{MS}$  and  $S_{M1}$  can be determined from

$$S_{MS} = F_a S_s \quad (20.2a)$$

$$S_{M1} = F_v S_1 \quad (20.2b)$$

where

$S_s$  = mapped maximum considered earthquake spectral response accelerations at short periods determined from Fig. 20.1a

$S_1$  = mapped maximum considered earthquake spectral response accelerations at 1-s period determined from Fig. 20.1b

$F_a, F_v$  = site coefficients

**Table 20.1** Risk Classification of Structures Based on Their Nature of Occupancy

Risk Category	Nature of Occupancy	Seismic Importance Factor, $I_e$
I	Buildings and other structures that represent a low hazard to human life in the event of failure including, but not limited to <ul style="list-style-type: none"> <li>• Agricultural facilities</li> <li>• Certain temporary facilities</li> <li>• Minor storage facilities</li> </ul>	1.00
II	Buildings and other structures except those listed in risk categories I, III, and IV	1.00
III	Buildings and other structures that represent a substantial hazard to human life in the event of failure including, but not limited to <ul style="list-style-type: none"> <li>• Buildings and other structures whose primary occupancy is public assembly with an occupant load greater than 300</li> <li>• Buildings and other structures with elementary school, secondary school, or day-care facilities with an occupant load greater than 250</li> <li>• Buildings and other structures containing adult education facilities such as colleges and university with an occupant load greater than 500</li> <li>• Group I-2 occupancies with an occupant load of 50 or more resident patients but not having surgery or emergency treatment facilities</li> <li>• Group I-3 occupancies</li> <li>• Any other occupancy with an occupant load greater than 5000</li> <li>• Power-generating stations, water treatment facilities for potable water, wastewater treatment facilities and other public utility facilities not included in category IV</li> <li>• Buildings and other structures not included in risk category IV containing quantities of toxic or explosive materials that:</li> </ul>	1.25
IV	Buildings and other structures designated as essential facilities including, but not limited to <ul style="list-style-type: none"> <li>• Buildings and other structures whose primary occupancy is public assembly with an occupant load greater than 300</li> <li>• Buildings and other structures with elementary school, secondary school, or day-care facilities with an occupant load greater than 250</li> <li>• Buildings and other structures containing adult education facilities such as colleges and university with an occupant load greater than 500</li> <li>• Group I-2 occupancies with an occupant load of 50 or more resident patients but not having surgery or emergency treatment facilities</li> <li>• Group I-3 occupancies</li> <li>• Any other occupancy with an occupant load greater than 5000</li> <li>• Power-generating stations, water treatment facilities for potable water, wastewater treatment facilities and other public utility facilities not included in category IV</li> <li>• Buildings and other structures not included in risk category IV containing quantities of toxic or explosive materials that:</li> </ul> <p>Exceed maximum allowable quantities per control area as given in Table 307.1(1) or 307.1(2) or per outdoor control area in accordance with the <i>International Fire Code</i>; and are sufficient to pose a threat to the public if released</p> <ul style="list-style-type: none"> <li>• Group I-2 occupancies having surgery or emergency treatment facilities</li> <li>• Fire, rescue, and police stations and emergency vehicle garages</li> <li>• Designated earthquake, hurricane, or other emergency shelters</li> <li>• Designated emergency preparedness, communication, and operation centers and other facilities required for emergency response</li> <li>• Power-generating stations and other public utility facilities required as emergency backup facilities for category IV structures</li> <li>• Buildings and other structures containing quantities of highly toxic materials that:</li> </ul>	1.50



**Table 20.1** (Continued)

Risk Category	Nature of Occupancy	Seismic Importance Factor, $I_e$
	Exceed maximum allowable quantities per control area as given in Table 307.1(2) or per outdoor control area in accordance with the <i>International Fire Code</i> and are sufficient to pose a threat to the public if released	
	<ul style="list-style-type: none"> <li>• Aviation control towers, air traffic control centers, and emergency aircraft hangers</li> <li>• Buildings and other structures having critical national defense functions</li> <li>• Water storage facilities and pump structures required to maintain water pressure for fire suppression</li> </ul>	

The parameters  $S_s$  and  $S_1$  shall be determined from 0.2- and 1-s spectral response acceleration shown in Figs. 20.1a and 20.1b. Where  $s_1 \leq 0.04$  and  $S_s \leq 0.15$ , the structure is permitted to be assigned seismic design category A.

The values of  $F_a$  and  $F_v$  are determined from Tables 20.2 and 20.3 and are dependent on the mapped spectral values ( $S_s$  and  $S_1$ ) and the site class as can be determined in Table 20.4 in accordance with Chapter 20 of ASCE 7-10. Where the soil properties are not known in sufficient detail to determine the site classes, site class D shall be used unless the building official or geotechnical data determines site class E or F soils are present at the site (IBC 2012, Section 1613.3.2).

### 20.2.3 Design Response Spectrum

Design response spectrum is used to determine the design spectral response acceleration for a given structure (i.e., given period of vibration). After calculating design response acceleration coefficients  $S_{DS}$  and  $S_{D1}$  from Section 20.2.2, the design response spectrum curve shown in Figure 20.3 (ASCE 7-10, Section 11.4.5) should be constructed as follows:

1. For periods  $T \leq T_0$ , the design spectral response acceleration,  $S_a$ , shall be determined as

$$S_a = S_{DS} \left( 0.4 + 0.6 \frac{T}{T_0} \right) \quad (20.3)$$

where

$$T_0 = 0.2 \frac{S_{D1}}{S_{DS}} \quad (20.4)$$

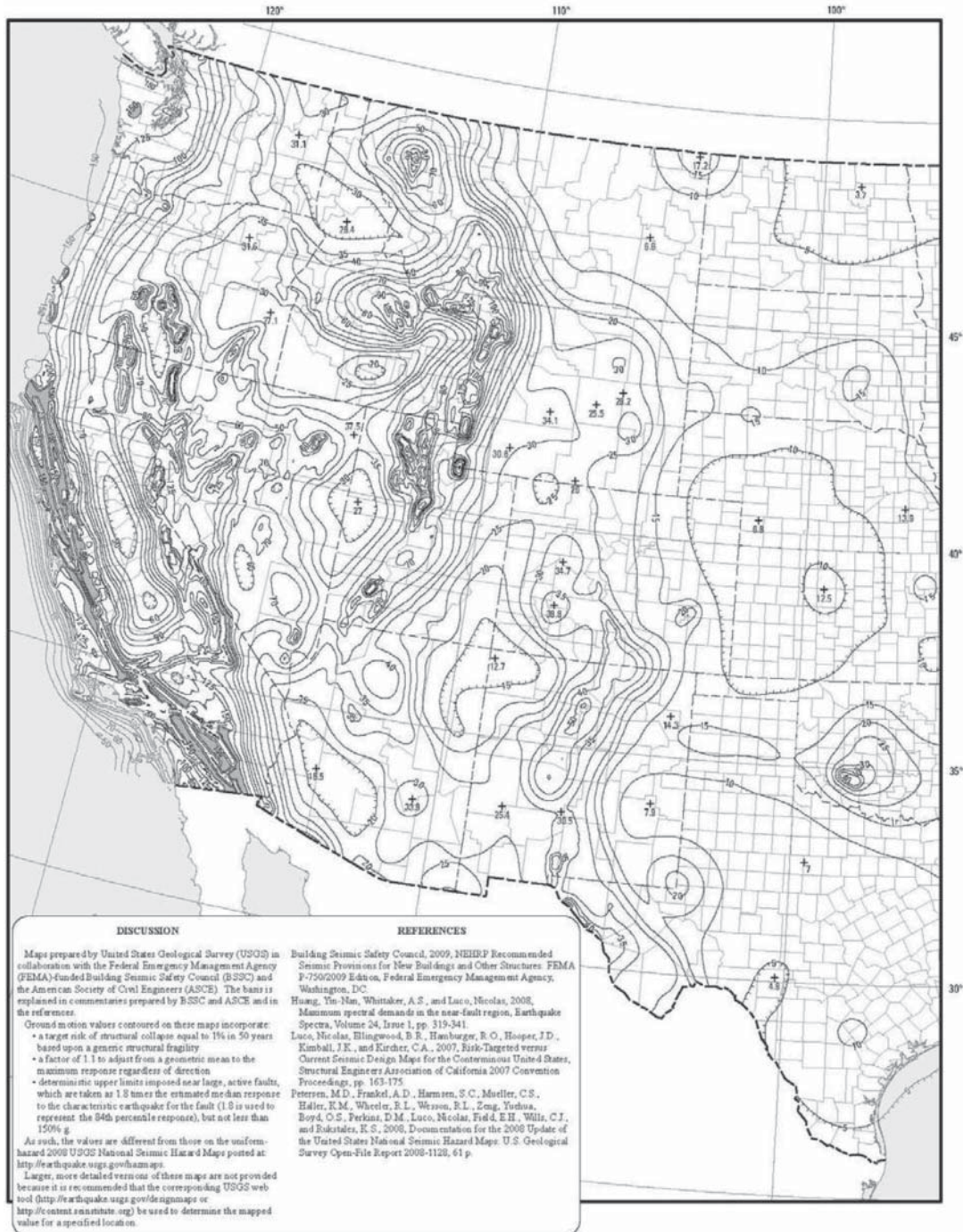
and  $T$  is the fundamental period of the structure (in seconds) determined in Section 20.3.1 (Eq. 20.16).

2. For periods  $T_0 \leq T \leq T_s$ , the design spectral response acceleration,  $S_a$ , shall be determined as

$$S_a = S_{DS} \quad (20.5)$$

where

$$T_s = \frac{S_{D1}}{S_{DS}} \quad (20.6)$$



**Figure 20.1a** Risk-targeted maximum considered earthquake spectral response acceleration at short periods,  $S_s$  [IBC Fig. 1613.3.1(1)]. Courtesy of International Code Council [2]. Reproduced by permission

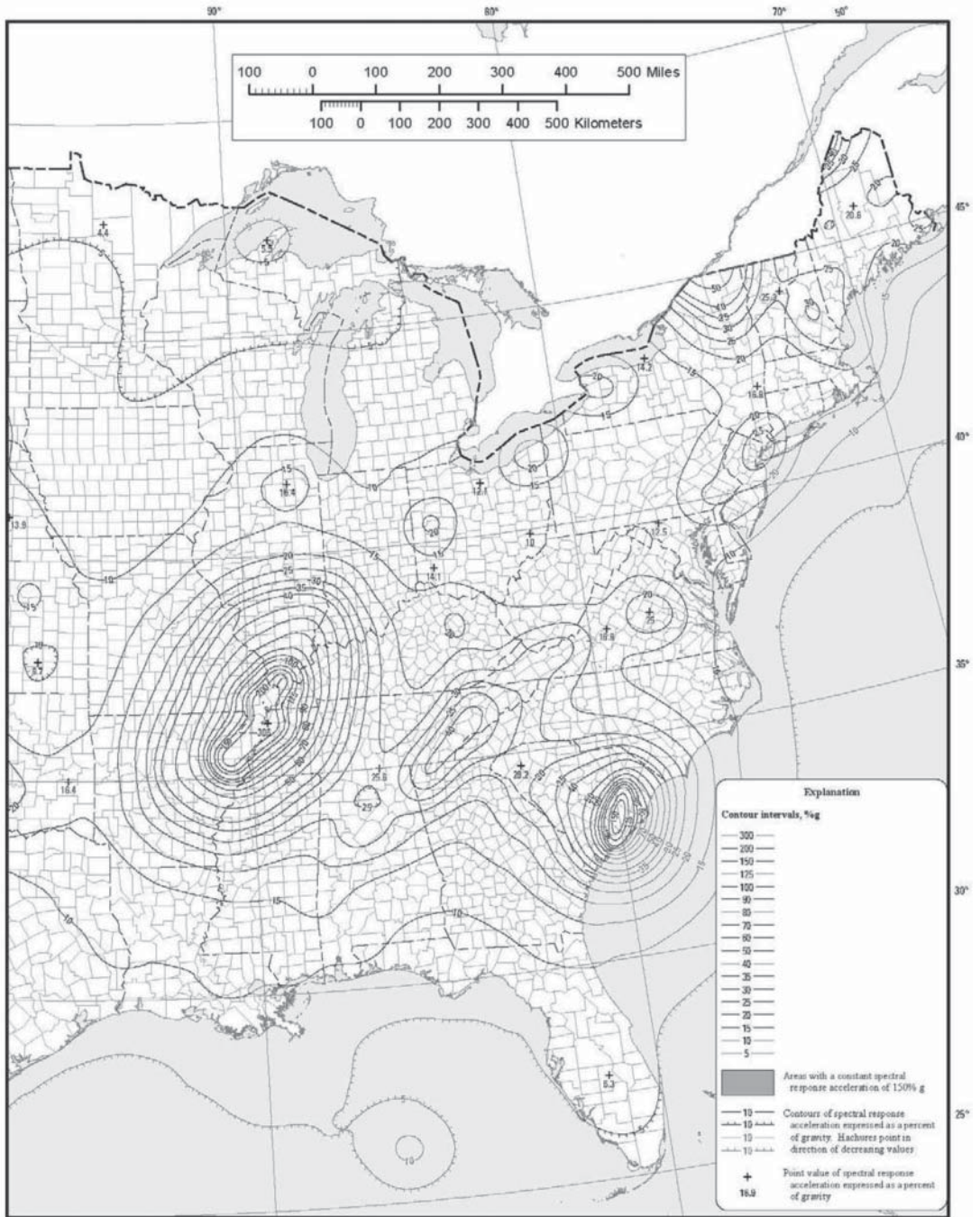
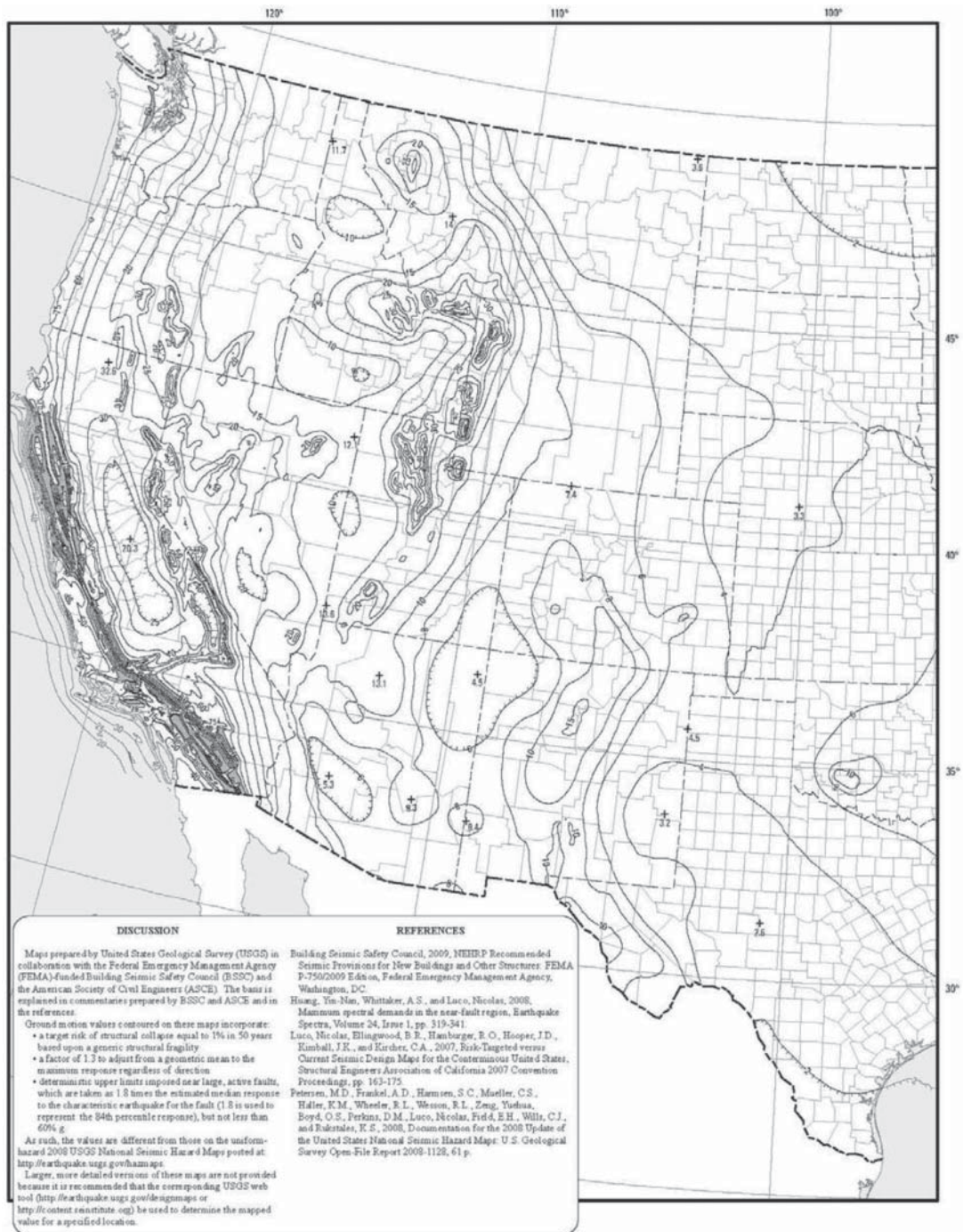


Figure 20.1a (Continued)



**Figure 20.1b** Risk-targeted maximum considered earthquake spectral response acceleration at 1-second periods,  $S_1$  [IBC Fig. 1613.3.1(2)]. Courtesy of International Code Council [2]. Reproduced by permission

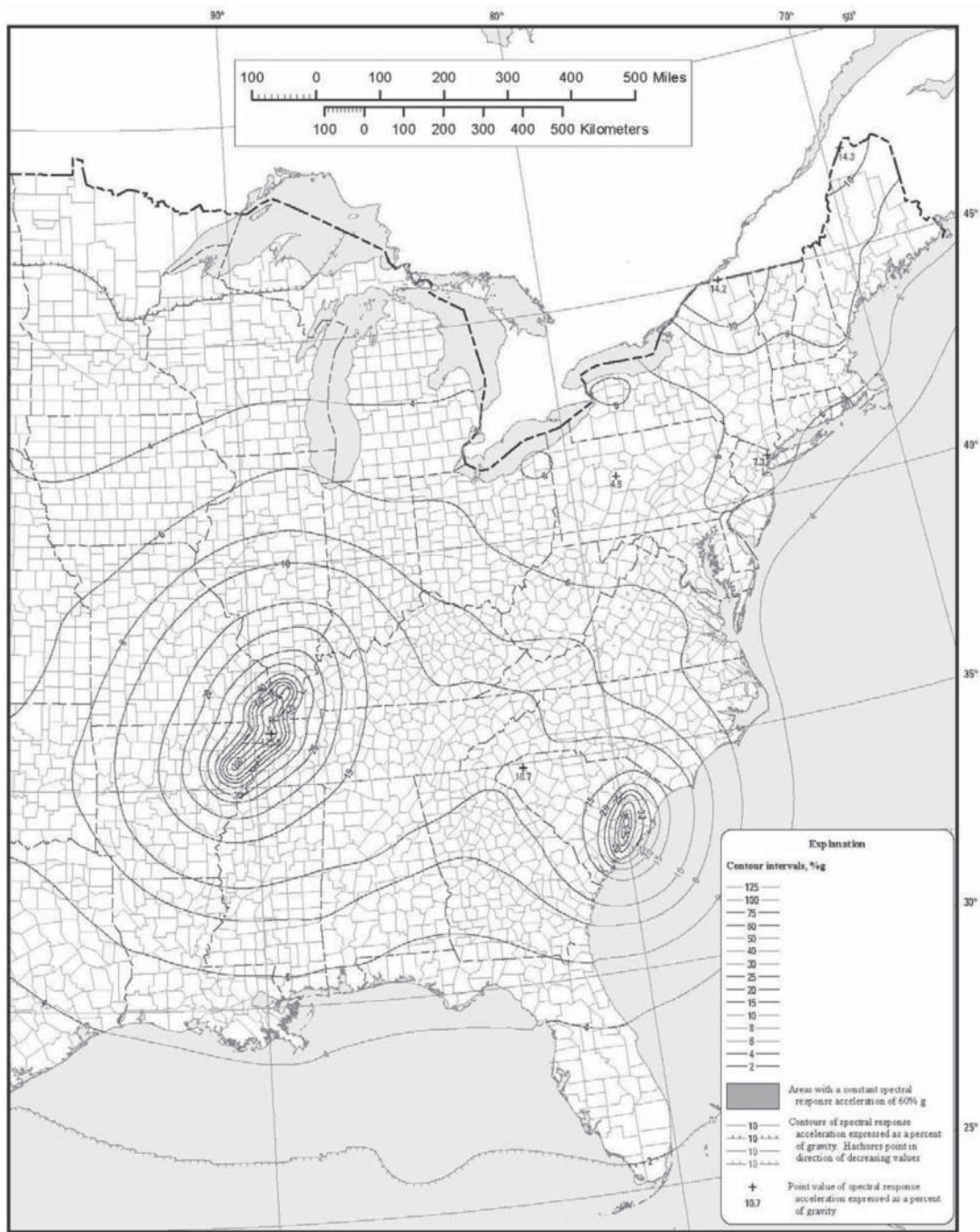


Figure 20.1b (Continued)

**Table 20.2** Values of Site Coefficient,  $F_a^a$  [Table 1613.3.3(1) of IBC 2012]

Site Class	Mapped Spectral Response Acceleration at Short Periods				
	$S_s \leq 0.25$	$S_s = 0.50$	$S_s = 0.75$	$S_s = 1.00$	$S_s \geq 1.25$
A	0.8	0.8	0.8	0.8	0.8
B	1.0	1.0	1.0	1.0	1.0
C	1.2	1.2	1.1	1.0	1.0
D	1.6	1.4	1.2	1.1	1.0
E	2.5	1.7	1.2	0.9	0.9
F	Note <i>b</i>	Note <i>b</i>	Note <i>b</i>	Note <i>b</i>	Note <i>b</i>

<sup>a</sup>Use straight-line interpolation for intermediate values of mapped spectral response acceleration at short period,  $S_s$ .

<sup>b</sup>Site-specific geotechnical investigation and dynamic site response analysis shall be performed to determine appropriate values, or in accordance with Section 11.4.7 of ASCE 7.

**Table 20.3** Values of Site Coefficient,  $F_v^a$  [Table 1613.3.3(2) of IBC 2012]

Site Class	Mapped Spectral Response Acceleration at 1-Second Period				
	$S_1 \leq 0.1$	$S_1 = 0.2$	$S_1 = 0.3$	$S_1 = 0.4$	$S_1 \geq 0.5$
A	0.8	0.8	0.8	0.8	0.8
B	1.0	1.0	1.0	1.0	1.0
C	1.7	1.6	1.5	1.4	1.3
D	2.4	2.0	1.8	1.6	1.5
E	3.5	3.2	2.8	2.4	2.4
F	Note <i>b</i>	Note <i>b</i>	Note <i>b</i>	Note <i>b</i>	Note <i>b</i>

<sup>a</sup>Use straight-line interpolation for intermediate values of mapped spectral response acceleration at 1-s period,  $S_1$ .

<sup>b</sup>Site-specific ground motion procedures in accordance with Section 11.4.7 of ASCE 7.

3. For periods  $T_s < T \leq T_L$ , the design spectral response acceleration,  $S_a$ , shall be determined as

$$S_a = \frac{S_{D1}}{T} \quad (20.7)$$

4. For periods greater than  $T_L$ ,  $S_a$  shall be taken as

$$S_a = \frac{S_{D1} T_L}{T^2} \quad (20.8)$$

where  $T_L$  is the long-period transition period(s) shown in Fig. 20.2a and 20.2b (conterminous United States), Fig. 20.2c (region 1), Fig. 20.2d (Alaska), Fig. 20.2e (Hawaii), Fig. 20.2f (Puerto Rico, Culebra, Vieques, St. Thomas, St. John, and St. Croix), and Fig. 20.2g (Guam and Tutuila).

#### 20.2.4 Determination of Seismic Design Category (SDC)

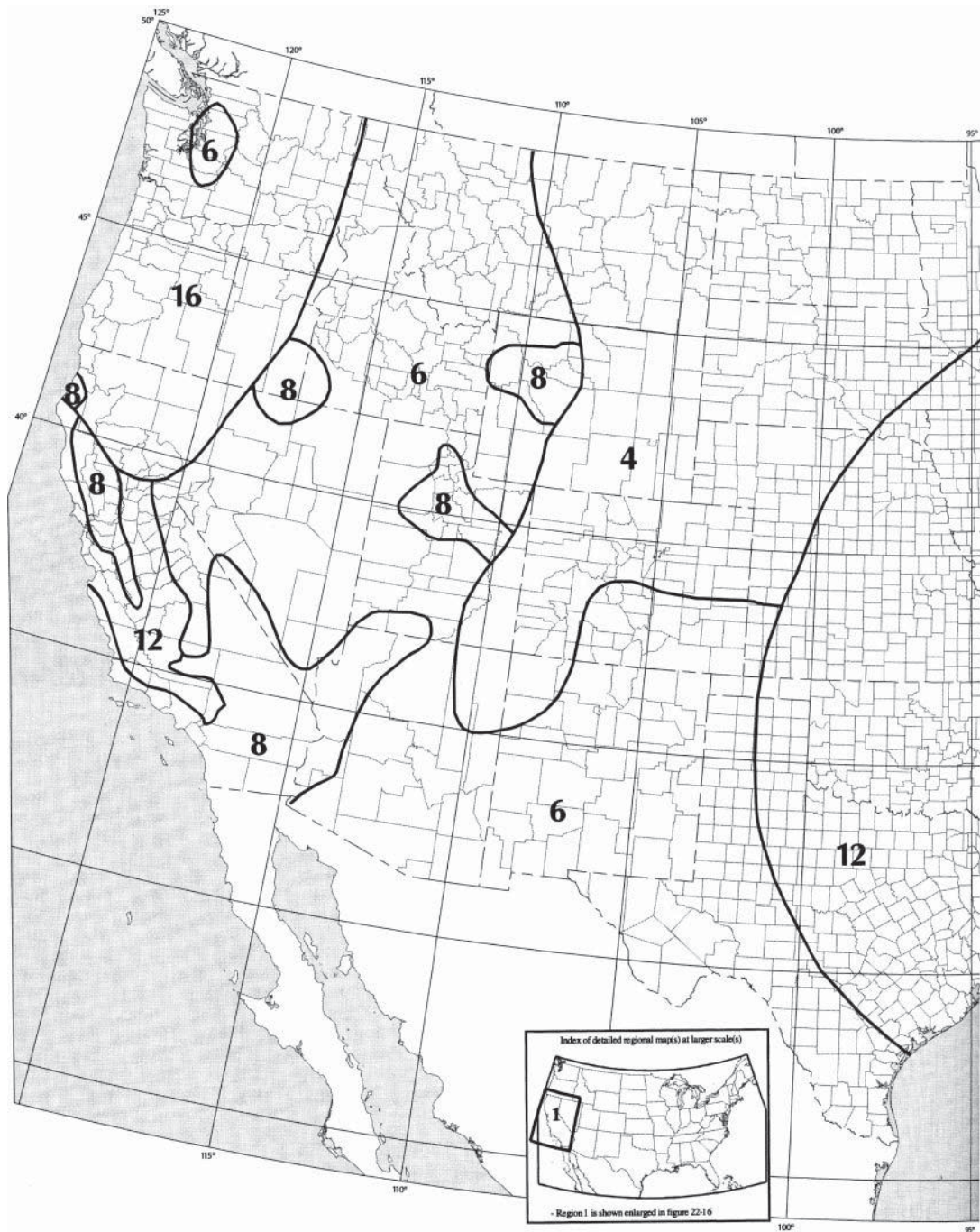
Structures shall be assigned SDCs, which are classified as A, B, C, D, E, and F and are determined from Tables 20.5 and 20.6. These have no relation to the site class types that are also named A, B,

**Table 20.4** Site Classification

Average Properties in Top 100 ft, as per ASCE 7-10 Section 20.4				
Site Class	Soil Profile Name	Soil Shear Wave Velocity, $\bar{V}_s$ (ft/s)	Standard Penetration Resistance, $\bar{N}$	Soil Undrained Shear Strength, $\bar{S}_u$ (psf)
A	Hard rock	$\bar{V}_s > 5000$	N/A	N/A
B	Rock	$2500 < \bar{V}_s \leq 5000$	N/A	N/A
C	Very dense soil and soft rock	$1200 < \bar{V}_s \leq 2500$	$\bar{N} > 50$	$\bar{S}_u \geq 2000$
D	Stiff soil	$600 < \bar{V}_s \leq 1200$	$15 \leq \bar{N} \leq 50$	$1000 \leq \bar{S}_u \leq 2000$
E	Soft clay soil	$\bar{V}_s \leq 600$	$\bar{N} < 15$	$\bar{S}_u \leq 1000$
<p>Any profile with more than 10 ft of soil having the following characteristics:</p> <ol style="list-style-type: none"> <li>1. Plasticity index (PI) &gt; 20</li> <li>2. Moisture content (<math>w</math>) <math>\geq 40\%</math></li> <li>3. Undrained shear strength <math>\bar{S}_u &lt; 500</math> psf</li> </ol> <p>Where any of the following conditions is satisfied, site shall be classified as site class F and a site response analysis in accordance with ASCE 7-10, Section 21.1</p> <ol style="list-style-type: none"> <li>1. Soils vulnerable to potential failure or collapse under seismic loading such as liquefiable soils, quick and highly sensitive clays, and collapsible weakly cemented soils.</li> </ol> <p><u>Exceptions:</u></p>				
F	Soil requiring site response analysis in accordance to ASCE 7-10, Section 21.1	<p>For structures having fundamental periods of vibration equal to or less than 0.5 sec., site response analysis is not required to determine spectral accelerations for liquefiable soils. Rather, a site class is permitted to be determined in accordance with ASCE 7-10, Section 20.3.</p> <ol style="list-style-type: none"> <li>2. Peats and/or highly organic clays [<math>(H &gt; 10</math> ft of peat and/or highly organic clay where <math>H</math> = thickness of soil)]</li> <li>3. Very high plasticity clays [<math>H &gt; 25</math> ft with plasticity index (PI) &gt; 75].</li> <li>4. Very thick soft/medium stiff clays (<math>H &gt; 120</math> ft) with <math>\bar{S}_u &lt; 1000</math> psf.</li> </ol>		

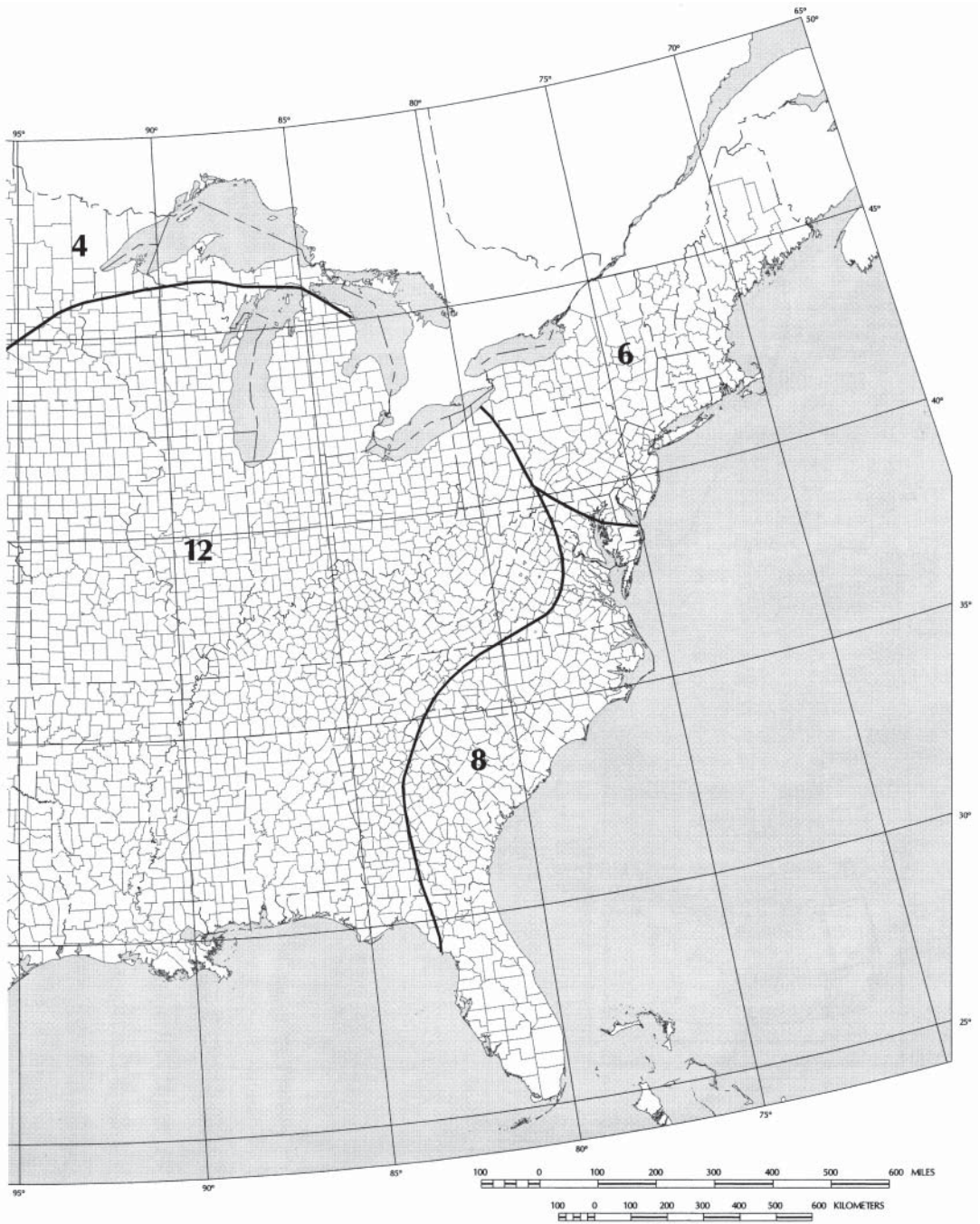
C, D, E, and F as described in Table 20.4. To determine the SDC, the values of  $S_{DS}$  and  $S_{D1}$  are utilized and the risk category must be defined.

Risk Category I, II, or III structures located where the mapped spectral response acceleration parameter at 1-s period,  $S_1$ , is greater than or equal to 0.75 shall be assigned to Seismic Design Category E. Risk Category IV structures located where the mapped spectral response acceleration parameter at 1-s period,  $S_1$ , is greater than or equal to 0.75 shall be assigned to Seismic Design Category F. All other structures shall be

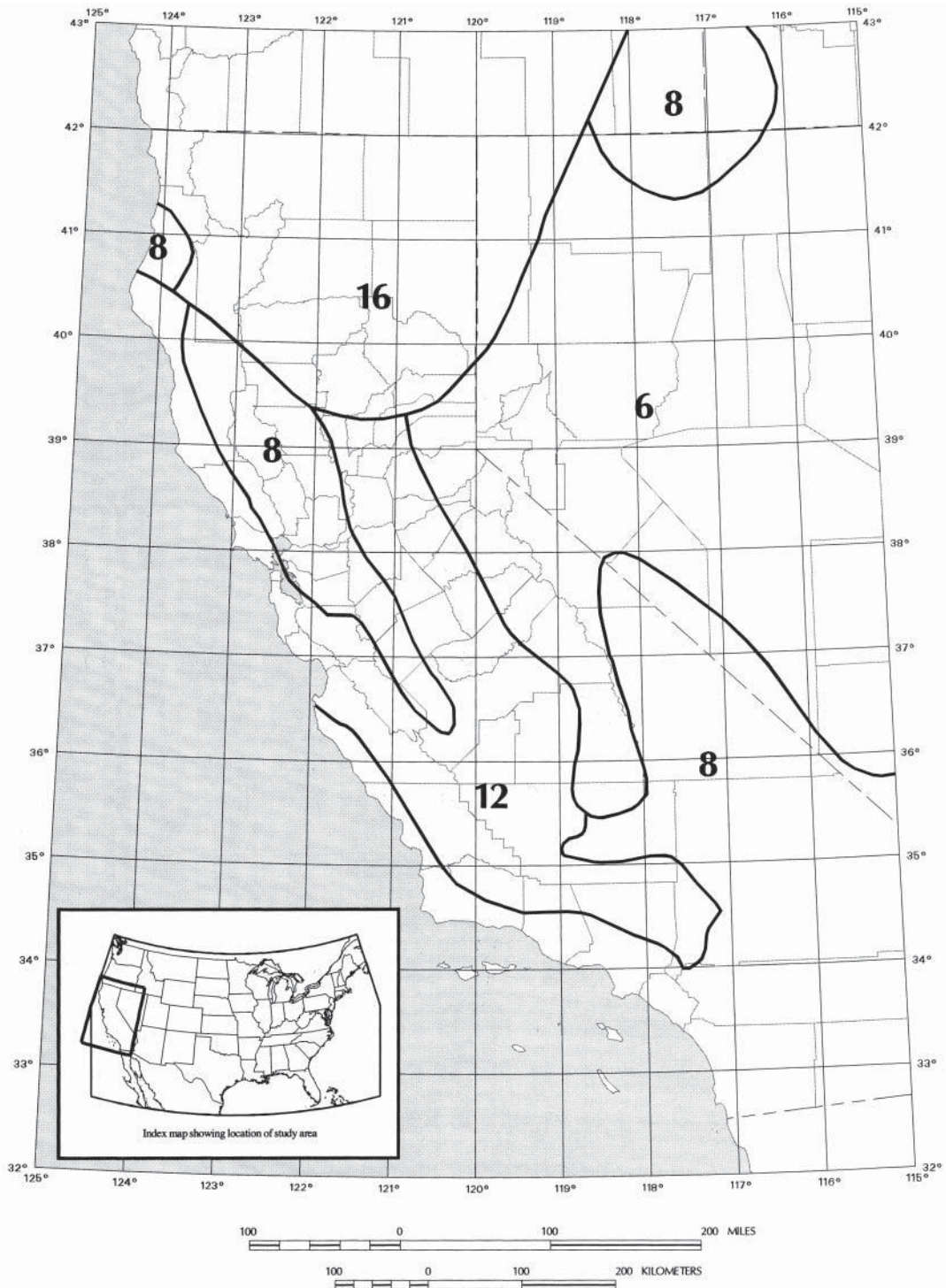


**Figure 20.2a** Long-period transition period,  $T_L$  (sec), for the conterminous United States. ASCE 7-10 Minimum Design Loads for Buildings and Other Structures, 2010. With permission from ASCE

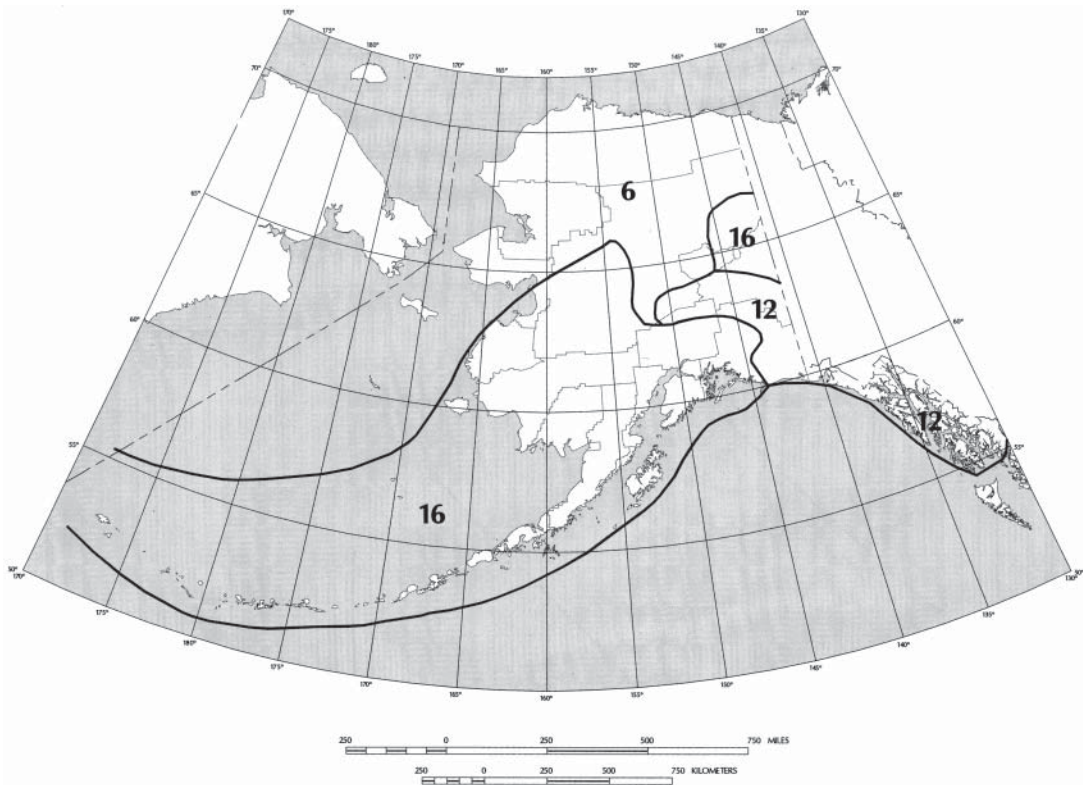




**Figure 20.2b** Long-period transition period,  $T_L$  (sec), for the conterminous United States (*continued*). ASCE 7-10 Minimum Design Loads for Buildings and Other Structures, 2010. With permission from ASCE



**Figure 20.2c** Long-period transition period,  $T_L$  (sec), for region 1. ASCE 7-10 Minimum Design Loads for Buildings and Other Structures, 2010. With permission from ASCE



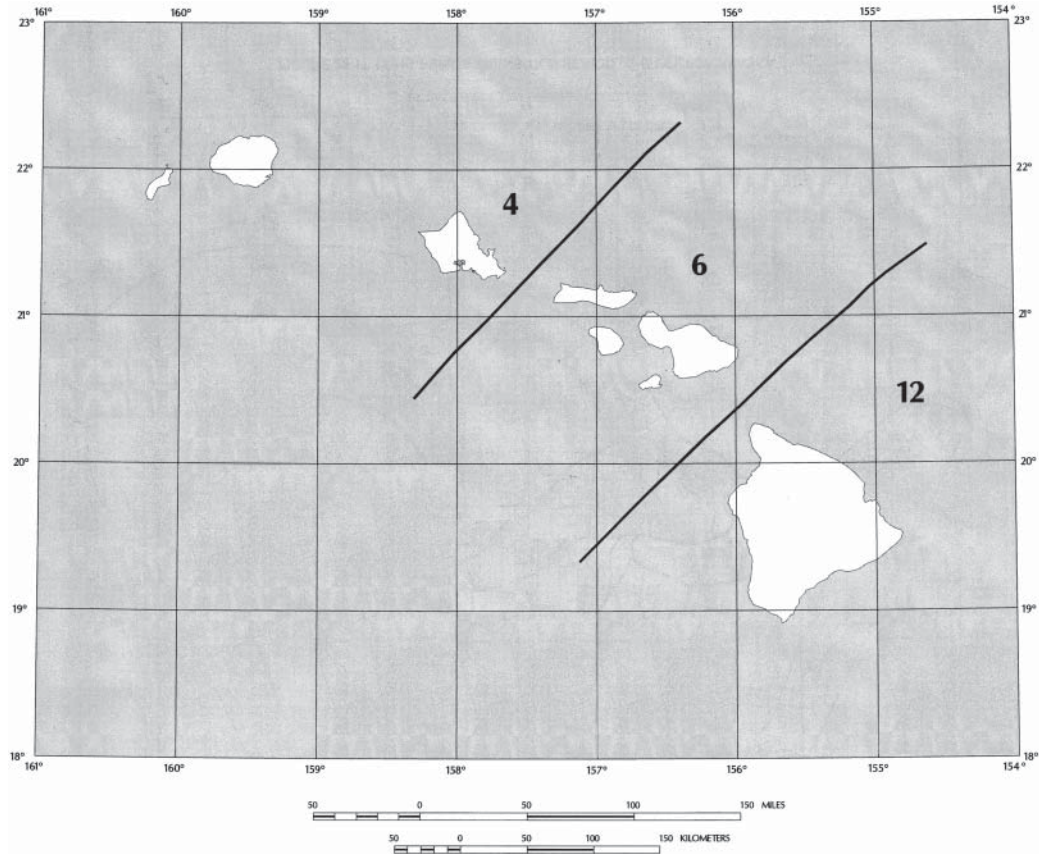
**Figure 20.2d** Long-period transition period,  $T_L$  (sec), for Alaska. ASCE 7-10 Minimum Design Loads for Buildings and Other Structures, 2010. With permission from ASCE

assigned to a Seismic Design Category based on their Risk Category and the design spectral response acceleration parameters,  $S_{DS}$  and  $S_{D1}$ , determined in Section 20.2.2. Each building and structure shall be assigned to the more severe Seismic Design Category in accordance with Table 20.5 or 20.6, irrespective of the fundamental period of vibration of the structure,  $T$ .

#### Alternate Design Category Determination

When  $S_1$  is less than 0.75, the Seismic Design Category is permitted to be determined from Table 20.5 alone, where all of the following apply:

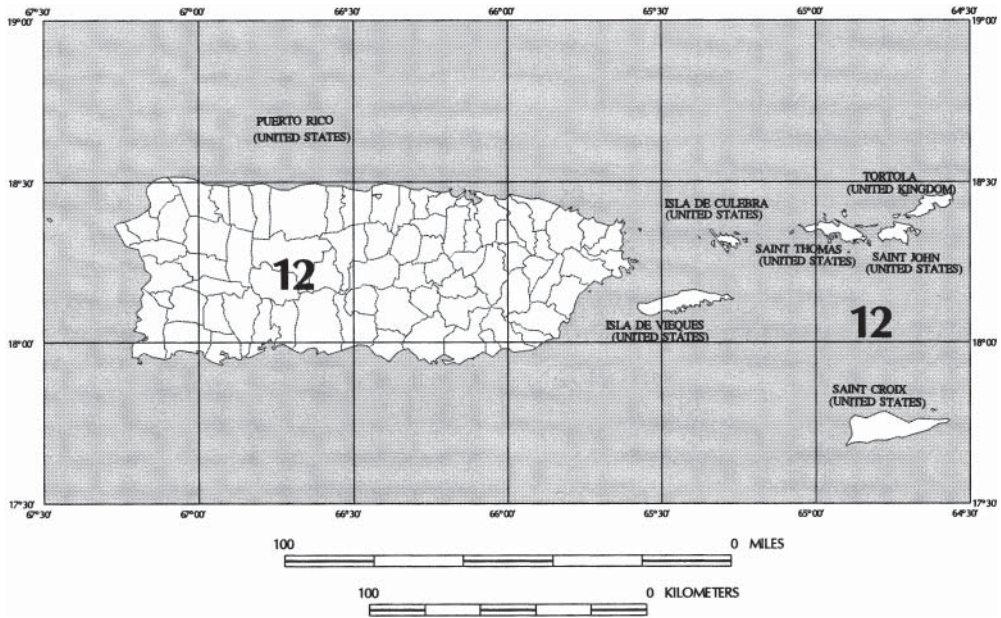
1. In each of the two orthogonal directions, the approximate fundamental period of the structure,  $T_a$ , determined in accordance with Section 20.3.1 is less than  $0.8 T_s$ , where  $T_s$  is determined in accordance with Section 20.2.3.
2. In each of two orthogonal directions, the fundamental period of the structure used to calculate the story drift is less than  $T_s$ .
3. The seismic response coefficient  $C_s$  is determined from  $C_s = S_{DS}/(R/I_e)$ .
4. The diaphragms are rigid; or for diaphragms that are flexible, the distance between vertical elements of the seismic force-resisting system does not exceed 40 ft.



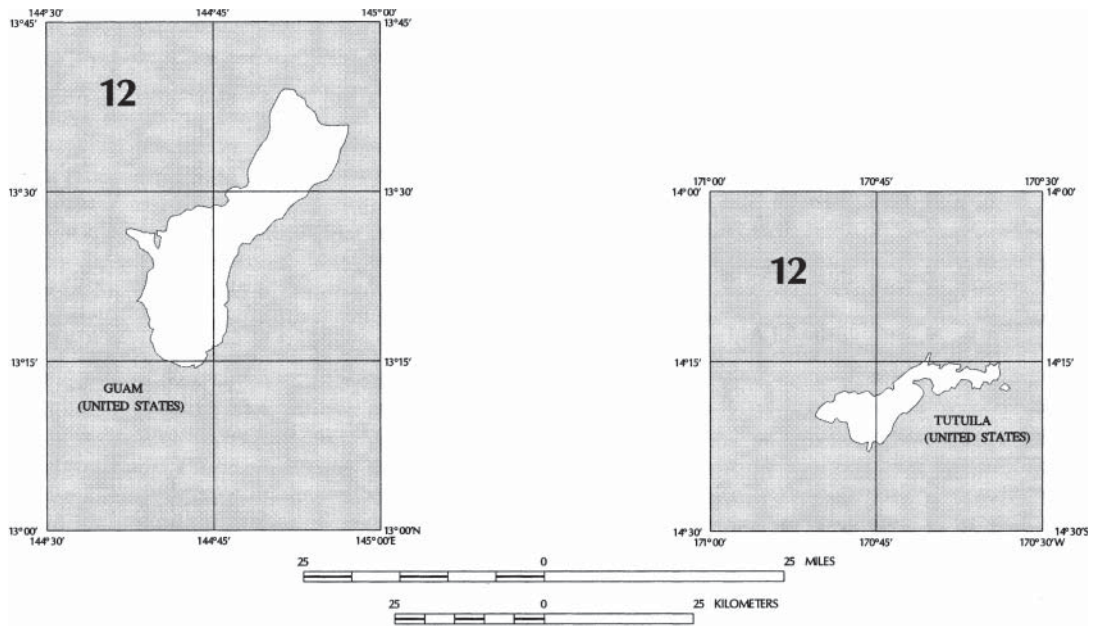
**Figure 20.2e** Long-period transition period,  $T_L$  (sec), for Hawaii. ASCE 7-10 Minimum Design Loads for Buildings and Other Structures, 2010. With permission from ASCE

### 20.2.5 Summary: Procedure for Calculation of Seismic Design Category (SDC)

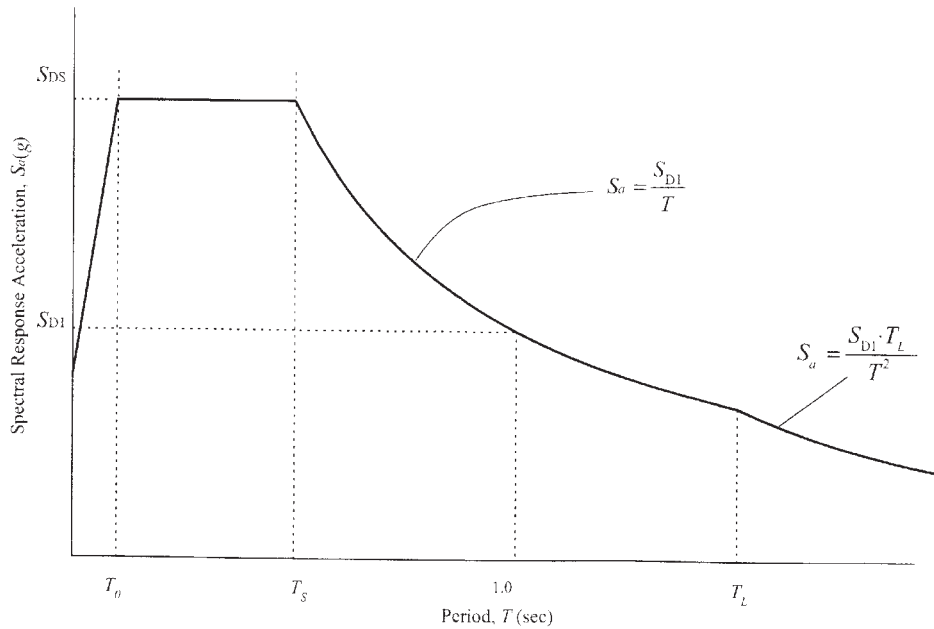
- Step 1.** Determine seismic use group as described in Section 20.2.1. (Table 20.1).
- Step 2.** Based on the location of the building, determine the mapped spectral accelerations for short periods,  $S_S$ , and the mapped spectral accelerations for a 1-s period. Use Fig. 20.1a and Fig. 20.2b of Section 20.2.2.
- Step 3.** Use Table 20.4 to determine site class based on the soil profile name, and properties of soil.
- Step 4.** Using Table 20.2, determine site coefficient  $F_a$  based on mapped maximum considered earthquake spectral response accelerations at short periods,  $S_S$ . Also, using Table 20.3 determine site coefficient  $F_v$  based on mapped maximum considered earthquake spectral response accelerations at 1-s period,  $S_1$ .
- Step 5.** Calculate the maximum considered earthquake spectral response accelerations for short periods for specific soil class,  $S_{MS}$ , using Eq. 20.2a. Also calculate the maximum considered earthquake spectral response accelerations for 1-s period for specific soil class,  $S_{M1}$ , using Eq. 20.2b.



**Figure 20.2f** Long-period transition period,  $T_L$  (sec), for Puerto Rico, Culebra, Vieques, St. Thomas, St. John, and St. Croix. ASCE 7-10 Minimum Design Loads for Buildings and Other Structures, 2010. With permission from ASCE



**Figure 20.2g** Long-period transition period,  $T_L$  (sec), for Guam and Tutuila. ASCE 7-10 Minimum Design Loads for Buildings and Other Structures, 2010. With permission from ASCE



**Figure 20.3** Design response spectrum. ASCE 7-10 Minimum Design Loads for Buildings and Other Structures, 2010. With permission from ASCE

**Table 20.5** Seismic Design Category Based on Short-Period Response Accelerations Parameter [Table 1613.3.5(1) of IBC 2012]

Value of $S_{DS}$	Risk Category		
	I or II	III	IV
$S_{DS} < 0.167 g$	A	A	A
$0.167 g \leq S_{DS} < 0.33 g$	B	B	C
$0.33 g \leq S_{DS} < 0.50 g$	C	C	D
$0.50 g \leq S_{DS}$	D	D	D

**Table 20.6** Seismic Design Category Based on 1-s Period Response Acceleration Parameter [Table 1613.3.5(2) of IBC 2012]

Value of $S_{D1}$	Risk Category		
	I or II	III	IV
$S_{D1} < 0.067 g$	A	A	A
$0.067 g \leq S_{D1} < 0.133 g$	B	B	C
$0.133 g \leq S_{D1} < 0.20 g$	C	C	D
$0.20 g \leq S_{D1}$	D	D	D

- Step 6.** Using Eq. 20.1a determine design spectral response acceleration coefficient for short periods,  $S_{DS}$ , and using Eq. 20.1b determine spectral response acceleration coefficient for 1-s period,  $S_{D1}$ .
- Step 7.** Determine SDC according to Section 20.2.4. Utilize Tables 20.5 and 20.6.

### Example 20.1

Determine seismic design category for a minor storage facility building in San Francisco on soft rock.

#### Solution

1. According to Table 20.1, minor storage facilities buildings are classified in risk category I.
2.  $S_S = 2.02 g$  (Fig. 20.1a)  
 $S_1 = 0.60 g$  (Fig. 20.2b)
3. According to the Table 20.4, a site with soft rock is considered to be class C.
4. According to the Table 20.2 for the site class C and  $S_S = 2.02 > 1.25$ ,  $F_a = 1.0$ .  
According to Table 20.3 for site class C and  $S_1 = 0.60 > 0.5$ ,  $F_v = 1.3$ .
5.  $S_{MS} = F_a S_S = (1.0)(2.02) = 2.02 g$  (Eq. 20.2a)  
 $S_{M1} = F_v S_1 = (1.3)(0.60) = 0.78 g$  (Eq. 20.2b)
6.  $S_{DS} = \frac{2}{3} S_{MS} = \frac{2}{3} (2.02) = 1.35 g$  (Eq. 20.1a)  
 $S_{D1} = \frac{2}{3} S_{M1} = \frac{2}{3} (0.78) = 0.52 g$  (Eq. 20.1b)
7. According to Table 20.5 for  $S_{DS} = 1.35 g > 0.50 g$ , risk category I, and since  $S_1 < 0.75 g$ , therefore SDC is category D.
8. According to Table 20.6 for  $S_{D1} = 0.52 g > 0.20 g$ , risk category I, and since  $S_1 < 0.75 g$ , therefore SDC is category D.

Therefore, seismic design category D is assigned to the structure.

### Example 20.2

Determine seismic design category for a hospital building in Oakland, California, on soft clay soil.

#### Solution

1. According to Table 20.1, hospital buildings are classified in the risk category IV.
2.  $S_S = 2.08 g$  (Fig. 20.1a)  
 $S_1 = 0.92 g$  (Fig. 20.2b)
3. According to Table 20.4, the site class for soft soil is E.
4. According to the Table 20.2, for the site class E and  $S_S = 2.08 > 1.25$ ,  $F_a = 0.9$ .  
According to the Table 20.3, for the site class E and  $S_1 = 0.92 > 0.5$ ,  $F_v = 2.4$ .
5.  $S_{MS} = F_a S_S = (0.9)(2.08) = 1.87 g$  (Eq. 20.2a)  
 $S_{M1} = F_v S_1 = (2.4)(0.92) = 2.21 g$  (Eq. 20.2b)
6.  $S_{DS} = \frac{2}{3} S_{MS} = \frac{2}{3} (1.87) = 1.25 g$  (Eq.20.1a)  
 $S_{D1} = \frac{2}{3} S_{M1} = \frac{2}{3} (2.21) = 1.47 g$  (Eq.20.1b)
7. According to Section 20.2.4, for  $S_{DS} = 1.25 g > 0.50 g$ , risk category IV, and since  $S_1 > 0.75 g$ , SDC is category F.
8. According to Section 20.2.4, for  $S_{D1} = 1.47 g > 0.20 g$ , risk category IV, and since  $S_1 > 0.75 g$ , SDC is class F.

Therefore, seismic design category F is assigned to the structure.

### 20.3 ANALYSIS PROCEDURES

During the earthquake motions, the structure is subjected to the deformation that produces internal forces and stresses. Earthquake engineering philosophy is to relate earthquake dynamic forces to the equivalent static forces, and then using static analysis of the structure, determine deformations, internal forces, and stresses in the structure. IBC describes two analysis procedures to determine the equivalent static forces that will simulate an earthquake action on the structure. These are

1. The equivalent lateral force procedure (used for SDC B, C, D, E, and F).
2. The simplified analysis (used for SDC B, C, D, E, and F, and for constructions limited to two stories in height and three stories in height for light frame constructions).

It should be noted that for the structures in SDC A, neither the simplified analysis nor the equivalent lateral force procedure could be utilized. This type of structure should be designed so that the lateral resisting-force system can resist the minimum design lateral force,  $F_x$ , applied at each floor level (ASCE 7-10, Sections 11.7 and 1.4.3). The design lateral force can be determined for this type of structure using the following equation:

$$F_x = 0.01w_x \quad (20.9)$$

where  $w_x$  is the portion of the dead load of the structure located or assigned to level  $x$ .

#### 20.3.1 Equivalent Lateral Force Procedure

This procedure describes how to calculate the seismic base shear and lateral seismic forces (ASCE 7-10, Section 12.8).

**Seismic Base Shear Calculation.** The total seismic force that acts at the base of the structure, called seismic base shear, can be determined according to the following equation:

$$V = C_s W \quad (20.10)$$

where

$C_s$  = seismic response coefficient

$W$  = effective weight of structure including total dead load and other loads listed below:

1. In areas used for storage, a minimum of 25% of the floor live load (floor live load in public garages and open parking structures need not be included).
2. Where an allowance for partition load is included in the floor load design, the actual partition weight or a minimum weight of 10 psf of floor area, whichever is greater (0.48 kN/m<sup>2</sup>).
3. Total operating weight of permanent equipment.
4. Twenty percent of flat roof snow load where flat snow load exceeds 30 psf (1.44 kN/m<sup>2</sup>).

**Seismic Response Coefficient Calculation.** The seismic response coefficient,  $C_s$ , shall be determined from:

$$C_s = \frac{S_{DS}}{R/I_e} \quad (20.11)$$

where

$S_{DS}$  = design spectral response acceleration parameter for short period as determined from Section 20.2.2.

$R$  = response modification factor given in Table 20.7

$I_e$  = seismic importance factor determined from Table 20.1



**Table 20.7** Design Coefficients and Factors for Basic Seismic Force-Resisting Systems

<b>Basic Seismic Force-Resisting System</b>	$R^a$	$\Omega_0^b$	$C_d^c$
<b>1. Bearing wall systems</b>			
Special reinforced concrete shear walls	5	2.5	5
Ordinary reinforced concrete shear walls	4	2.5	4
Detailed plain concrete shear walls	2	2.5	2
Ordinary plain concrete shear walls	1.5	2.5	1.5
<b>2. Building frame systems</b>			
Special reinforced concrete shear walls	6	2.5	5
Ordinary reinforced concrete shear walls	5	2.5	4.5
Detailed plain concrete shear walls	2	2.5	2
Ordinary plain concrete shear walls	1.5	2.5	1.5
<b>3. Moment-resisting frame systems</b>			
Special reinforced concrete moment frames	8	3	5.5
Intermediate reinforced concrete moment frames	5	3	4.5
Ordinary reinforced concrete moment frames	3	3	2.5
<b>4. Dual systems with special moment frames</b>			
Special reinforced concrete shear walls	7	2.5	5.5
Ordinary reinforced concrete shear walls	6	2.5	5
<b>5. Dual systems with intermediate moment frames</b>			
Special reinforced concrete shear wall	6.5	2.5	5
Ordinary reinforced concrete shear wall	5.5	2.5	4.5
<b>6. Shear wall-frame interactive system with ordinary reinforced concrete moment frames and ordinary reinforced concrete shear walls</b>			
Special reinforced concrete moment frames	2.5	1.25	2.5
Intermediate reinforced concrete moment frames	1.5	1.25	1.5
Ordinary reinforced concrete moment frames	1.0	1.25	1.0

<sup>a</sup>Response modification coefficient.

<sup>b</sup>Overstrength factor.

<sup>c</sup>Deflection amplification factor.

Source: ASCE 7-10 *Minimum Design Loads for Buildings and Other Structures*, 2010. With permission from ASCE.

The value of  $C_s$  should not exceed

$$C_{s,max} = \begin{cases} \frac{S_{D1}}{T(R/I_e)} & \text{for } T \leq T_L \\ \frac{S_{D1}T_L}{T^2(R/I_e)} & \text{for } T > T_L \end{cases} \quad (20.12a)$$

$$C_{s,max} = \begin{cases} \frac{S_{D1}T_L}{T^2(R/I_e)} & \text{for } T \leq T_L \\ \frac{S_{D1}}{T(R/I_e)} & \text{for } T > T_L \end{cases} \quad (20.12b)$$

where

$S_{D1}$  = design spectral response acceleration parameter at a period of 1.0 s, as determined from Section 20.2.2 (ASCE 7-10, Section 11.4.4)

$T$  = fundamental period of structure(s) determined in Section 20.3.1 (Eq. 20.15 or 20.16)

$T_L$  = lone-period transition period(s) determined in Section 20.2.3

Also,  $C_s$  should not be less than:

$$C_s = 0.44S_{DS}I_e \geq 0.01 \quad (20.13)$$

For structures for which the 1-s spectral response acceleration,  $S_1$ , is equal to or greater than 0.6 g, the value of the seismic coefficient,  $C_s$ , should not be taken less than

$$C_{s,\min} = \frac{0.5S_1}{R/I_e} \quad (20.14)$$

The response modification factor,  $R$ , is a function of several factors. Some of them are ductility capacity and inelastic performance of structural materials and systems during past earthquakes. Values of  $R$  for concrete structures are given in Table 20.7, and are selected by defining the type of basic seismic force-resisting system for structures (Table 12.2-1 of ASCE 7-10).

**Fundamental Period.** Elastic fundamental period,  $T$ , is a function of the mass and the stiffness of the structure. If the building is not designed, the period  $T$  cannot be precisely determined. On the other hand, to design a building, the period of vibration should be known, and included in equations for design. That is why building codes provide equations for calculation of approximate periods of vibrations,  $T_a$ . Calculated approximate periods are shorter than the real periods of structure, which leads to higher base shear values, and as a result safe design.

An approximate period of vibration,  $T$ , can be determined using the following equation:

$$T_a = C_t h_n^x \quad (20.15)$$

where  $h_n$  is the height in feet above the base to the highest level of the structure, and the coefficients  $C_t$  and  $x$  are determined from Table 20.8.

For the concrete moment-resisting frame buildings that do not exceed 12 stories in height and have an average minimum story height of 10 ft, the approximate period of vibration,  $T$ , can be determined using the following equation:

$$T_a = 0.1N \quad (20.16)$$

where  $N$  is the number of stories in the building above the base.

**Lateral Seismic Force Calculation.** Vertical distribution of the base shear force produces seismic lateral forces,  $F_x$ , at any floor level. Seismic lateral forces act at the floor levels because masses of the structure are concentrated at the floor levels. It is known that the force is a product of mass and acceleration. Earthquake motions produce accelerations of the structure and induce forces at the places of mass concentrations (i.e., floor levels).

**Table 20.8** Values of Approximate Period Parameters  $C_t$  and  $x$  (Non-Metric)

Structure Type	$C_t$	$x$
Moment-resisting frame systems in which the frames resist 100% of the required seismic force and are not enclosed or adjoined by components that are more rigid and will prevent the frames from deflecting where subjected to seismic forces:		
Steel moment-resisting frames	0.028	0.8
Concrete moment-resisting frames	0.016	0.9
Steel eccentrically braced frames	0.03	0.75
Steel buckling-restrained braced frames	0.03	0.75
All other structural systems	0.02	0.75

Source: ASCE 7-10 Minimum Design Loads for Buildings and Other Structures, 2010. With permission from ASCE.

The lateral force that will be applied to level  $x$  of the structure,  $F_x$ , can be determined from the following equation:

$$F_x = C_{vx} V \quad (20.17)$$

$$C_{vx} = \frac{w_x h_x^k}{\sum_{i=1}^n w_i h_i^k} \quad (20.18)$$

where

- $C_{vx}$  = vertical distribution factor
- $k$  = distribution exponent related to building period
- $k = 1$  for building having a period of  $T \leq 0.5$  s
- $k = 2$  for building having a period of  $T \geq 2.5$  s
- $k = 2$ , or linear interpolation between 1 and 2, for buildings having a period of  $0.5 \text{ s} \leq T \leq 2.5 \text{ s}$
- $h_i, h_x$  = height from base to level  $i$  and  $x$
- $w_i, w_x$  = portion of total effective seismic weight of the structure,  $W$ , located or assigned to level  $i$  or  $x$
- $n$  = number of stories
- $V$  = total design lateral force or shear at base of the structure

### 20.3.2 Summary: Equivalent Lateral Procedure

- Step 1.** Determine seismic design category according to Section 20.2 and choose an appropriate  $I_e$  value from Table 20.1.
- Step 2.** Choose  $R$  value from Table 20.7.
- Step 3.** Determine  $T$  using Eq. 20.15 or 20.16, as applicable.
- Step 4.** Calculate  $C_s$  using Eq. 20.11 and check for  $C_{s,\max}$  (Eq. 20.12a or Eq. 20.12b) and  $C_{s,\min}$  (Eq. 20.13 or 20.14, whichever is applicable). Ensure that  $C_{s,\min} \leq C_s \leq C_{s,\max}$  and

$$\text{if } C_s > C_{s,\max}, \text{ then choose } C_s = C_{s,\max}.$$

$$\text{if } C_s < C_{s,\min}, \text{ then choose } C_s = C_{s,\min}.$$

- Step 5.** Calculate effective seismic weight,  $W$ , as described in Section 20.3.1.
- Step 6.** Calculate seismic base shear using Eq. 20.10.
- Step 7.** Using Eq. 20.17, calculate seismic lateral load,  $F_x$ , for every level of the structure.

### 20.3.3 Simplified Analysis

The simplified analysis procedure for seismic design described in Section ASCE 7-10, Section 12.14.8.1, is applicable to any structure that satisfies the following limitations and conditions:

The seismic base shear and lateral seismic forces are calculated as follows:

- The structure shall qualify for risk category I and II.
- The site class shall not be class E or F.
- The structure shall not exceed three stories in height above grade.
- The seismic force resisting system shall be either a bearing wall system, or building frame system.

- The structure shall have at least two lines of lateral resistance in each of two major axis directions.
- 1. The seismic base shear,  $V$ , in a given direction shall be determined in accordance with

$$V = \frac{FS_{DS}}{R}W \quad (20.19)$$

where

$$S_{DS} = \frac{2}{3}F_aS_s$$

where  $F_a$  is permitted to be taken as 1.0 for rock sites, 1.4 for soil sites, or determined in accordance with Section 20.2.2. For the purpose of this section, sites are permitted to be considered to be rock if there is no more than 10 ft (3 m) of soil between the rock surface and the bottom of the spread footing or mat foundation. In calculating  $S_{DS}$ ,  $S_s$  shall be in accordance with Section 20.2.2, but need not be taken larger than 1.5.

$F = 1.0$  for one-story buildings above grade plane

$F = 1.1$  for two-story buildings above grade plane

$F = 1.2$  for three-story buildings above grade plane

$R =$  response modification factor from Table 20.7 (ASCE 7-10, Table 12.2-1)

$W =$  effective seismic weight of structure that shall include total dead and other loads listed in the following text (ASCE 7-10, Section 12.14.8.1)

- (a) In areas used for storage, a minimum of 25% of the floor live load.
    - Exceptions:
      - i. Where the inclusion of storage loads adds no more than 5% to the effective seismic weight at that level, it need not be included in the effective seismic weight.
      - ii. Floor live load in public garages and open parking structures need not be included.
  - (b) Where provision for partitions is required by ASCE 7-10, Section 4.3.2 (Provision for Partitions) in the floor load design, the actual partition weight, or minimum weight of 10 psf (0.48 kN/m<sup>2</sup>) of floor area, whichever is greater.
  - (c) Total operating weight of permanent equipment.
  - (d) Where the flat roof snow load,  $P_f$ , exceeds 30 psf (1.44 kN/m<sup>2</sup>), 20% of the uniform design snow load, regardless of actual roof slope.
2. The lateral seismic forces calculation: Lateral seismic forces can be determined from (ASCE 7-10, Section 12.14.8.2)

$$F_x = \frac{FS_{DS}}{R}w_x \quad (20.20)$$

where

$F_x =$  seismic force applied at level  $x$

$w_x =$  portion of effective seismic weight of structure,  $W$ , at level  $x$

#### 20.3.4 Summary: Simplified Analysis Procedure

- Step 1.** Check whether the structure satisfies conditions described in Section 20.3.3 for qualification for the simplified analysis procedure.
- Step 2.** Determine the value of  $S_{DS}$  as described in Section 20.2.2.
- Step 3.** Choose appropriate  $R$  factor from Table 20.7.
- Step 4.** Determine the effective seismic weight,  $W$ , of the structure as described in Section 20.3.3.

**Step 5.** Utilize Eq. 20.19 to calculate seismic base shear,  $V$ .

**Step 6.** Determine seismic lateral forces acting on the structure,  $F_x$ , using Eq. 20.20.

### 20.3.5 Design Story Shear

The seismic lateral forces will produce seismic design story shear,  $V_x$ , at any story  $x$ . They can be determined from the following equation:

$$V_x = \sum_{i=1}^n F_i \quad (20.21)$$

where

$F_i$  = portion of seismic base shear,  $V$ , induced to level  $i$   
 $n$  = number of stories

The seismic story shear in any story  $x$  should be collected and transferred to the story below by vertical elements of lateral force-resisting system. The distribution of story shear on vertical elements depends on flexibility of the diaphragm, which those elements support.

There are two types of diaphragm:

1. *Flexible diaphragms:* A flexible diaphragm changes shape when subjected to a lateral load. Its tension chord bends outward, and its compression chord bends inward. A flexible diaphragm is assumed to be incapable of transmitting torsion to lateral load-resisting elements.
2. *Rigid diaphragms:* A rigid diaphragm does not change its plan shape when subjected to lateral loads. It remains the same size, and the square corners remains square. There is no flexure. Rigid diaphragms are capable of transmitting torsion to the major lateral load-resisting elements. The lateral story shear is distributed to the resisting elements in proportion to relative rigidities of those elements.

A diaphragm is flexible when its computed maximum in-plane lateral deflection is more than two times the average story drift of the story that supports the diaphragm. To determine if a diaphragm is flexible, compare the in-plane deflection at the midpoint of the diaphragm to the story drift of the adjoining vertical resisting elements under equivalent tributary load. Lateral deformation of a diaphragm is maximum in-plane deflection of the diaphragm under lateral load, and the story drift is the difference between deflection of center of masses at the top and bottom of the story being considered.

A diaphragm that is not flexible by the above definition is rigid.

For flexible diaphragms, the seismic story shear,  $V_x$ , is distributed to vertical elements in the story  $x$  based on the area of the diaphragm tributary to each line of resistance. The vertical elements of the seismic-force-resisting system may be considered to be in the same line of resistance if the maximum out-of-plane offset between such elements is less than 5% of the building dimension perpendicular to the direction of the lateral force.

For rigid diaphragms,  $V_x$  is distributed to the vertical elements in the story  $x$  based on relative lateral stiffnesses of vertical lateral-load resisting elements, and the diaphragm.

### 20.3.6 Torsional Effects

For a rigid diaphragm, eccentricity between center of mass and center of rigidity can occur. The lateral shear force of each level is applied to the center of mass of that level. Distribution of  $V_x$  to vertical elements can be determined when the shear force acts to the center of rigidity. When the

shear force moves from center of mass to the center of rigidity, it produces a torsional moment. The effect of torsional moment will increase horizontal forces on vertical elements. Forces are not to be decreased due to torsional effects:

$$T = V_x e \quad (20.22)$$

where

$T$  = torsional moment

$V_x$  = base shear at level  $x$  in any direction

$E$  = eccentricity between center of mass and center of rigidity. It can occur in both directions:  $x$  and  $y$ .

### 20.3.7 Overturning Moment

The lateral seismic force  $F_x$  produces overturning moments. Overturning moment  $M_x$  should be calculated using the following equation:

$$M_x = \tau \sum_{i=1}^n F_i (h_i - h_x) \quad (20.23)$$

where

$M_x$  = overturning moment at level  $x$

$F_i$  = portion of seismic base shear,  $V$ , induced at level  $i$

$h_i, h_x$  = height from base to level  $i$  and  $x$

$\tau$  = overturning moment reduction factor

= 1.0 for top 10 stories

= 0.8 for twentieth story from the top and below

= linear interpolation between 1.0 and 0.8 for stories between twentieth and tenth stories below top

Reduction factor  $\tau$  is permitted to be taken as 1.0 for the full height of the structure.

### 20.3.8 Lateral Deformation of the Structure

The seismic lateral forces should be used in calculating deformations of the structure. The value that is of interest for engineers is story drift—the difference between the deflections of the center of mass at the top and the bottom of the story being considered. The value of story drift under seismic forces is important from different perspectives: stability of the structure, potential damage to nonstructural elements, and human comfort. The allowable values for story drift are shown in Table 20.9 (Table 12.12-1 of ASCE 7-10).

For structures that can be designed based on simplified analysis procedure described in Section 20.3.3, the drift can be taken as 1% of the story height unless a more exact analysis is provided:

$$\Delta = 0.01 h_x \quad (20.24)$$

The value of the design story drift should be less than or equal to the value of allowable story drift,  $\Delta_a$ , given in Table 20.9.

For all other structures that cannot be analyzed using the simplified analysis procedure, the drift should be determined as follows:

1. Calculate the deflection  $\delta_x$  at level  $x$  from the following equation:

$$\delta_x = \frac{C_d \delta_{xe}}{I_E} \quad (20.25)$$

**Table 20.9** Allowable Story Drift,  $\Delta_a$  (in.)<sup>a</sup>

Structure	Risk Category		
	I or II	III	IV
Structures, other than masonry shear wall structures, four stories or less above the base in height with interior walls, partitions, ceilings, and exterior wall systems that have been designed to accommodate the story drifts	$0.025 h_{sx}$ <sup>c</sup>	$0.020 h_{sx}$	$0.015 h_{sx}$
Masonry cantilever shear wall structures <sup>d</sup>	$0.010 h_{sx}$	$0.010 h_{sx}$	$0.010 h_{sx}$
Other masonry shear wall structures	$0.007 h_{sx}$	$0.007 h_{sx}$	$0.007 h_{sx}$
All other structures	$0.020 h_{sx}$	$0.015 h_{sx}$	$0.010 h_{sx}$

<sup>a</sup> $h_{sx}$  is the story height below level  $x$ .

<sup>b</sup>For seismic-force-resisting systems comprised solely of moment frames in seismic design categories D, E, and F, the allowable story drift shall comply with the requirements of ASCE7-10, Section 12.12.1.1.

<sup>c</sup>There shall be no drift limit for single-story structures with interior walls, partitions, ceilings, and exterior wall systems that have been designed to accommodate the story drift.

<sup>d</sup>Structures in which the basic structural system consists of masonry shear walls designed as vertical elements cantilevered from their base or foundation support that are so constructed that moment transfer between shear walls (coupling) is negligible. Source: ASCE 7-10 *Minimum Design Loads for Buildings and Other Structures*, 2010. With permission from ASCE.

where

$\delta_x$  = maximum inelastic response displacement

$\delta_{xe}$  = design-level elastic lateral displacement at floor level  $x$  under seismic lateral forces

$C_d$  = deflection amplification factor from Table 20.7

$I_e$  = occupancy importance factor from Table 20.1

- The design story drift can then be calculated as the difference between the deflections of the centers of masses of any two adjacent stories. Definition of story drift is shown in Fig. 20.4.

$$\Delta = \delta_x - \delta_{x-1} \quad (20.26)$$

- Check for the  $P$ -delta effect and adjust for magnification factor if needed.

**$P$ -Delta Effect.** An accurate estimate of story drift can be obtained by the  $P$ -delta analysis. In first-order structural analysis, the equilibrium equations are formulated for the un-deformed shape of a structure. When deformations are significant, the second-order analysis must be applied, and the  $P$ -delta effect must be considered in determining the overall stability of the structure. The  $P$ -delta effect does not need to be applied when the ratio of secondary to primary moment,  $\theta$ , does not exceed 0.1. This ratio is given by the following equation:

$$\theta = \frac{p_x \Delta I_e}{V_x h_{sx} C_d} \quad (20.27)$$

where

$\theta$  = stability coefficient

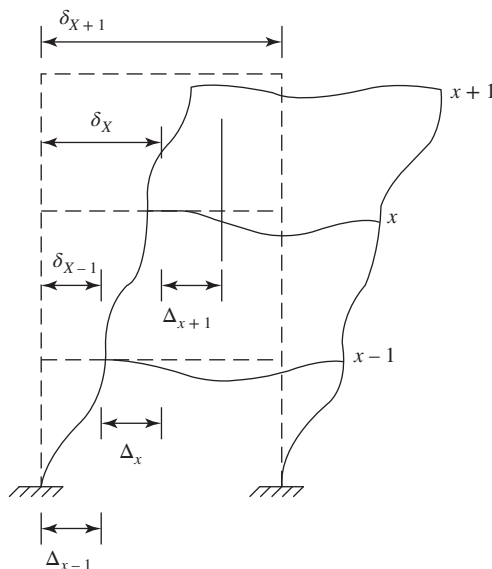
$P_x$  = total unfactored vertical design load at and above level  $x$  (*dead, floor live, and snow load*)

$\Delta$  = design story drift (in.)

$V_x$  = seismic shear force between level  $x$  and  $x-1$

$h_{sx}$  = story height below level  $x$  (in.)

$C_d$  = deflection amplification factor from Table 20.7 (Table 12.2-1 of ASCE7-10)



**Figure 20.4** Definition of drift.

The stability coefficient,  $\theta$ , should not exceed

$$\theta_{\max} = \frac{0.5}{C_d \beta} \leq 0.25 \quad (20.28)$$

where  $\beta$  is the ratio of shear demand to shear capacity for the story between level  $x$  and  $(x-1)$ . A conservative value of  $\beta = 1$  can be used where the ratio is not calculated.

If  $\theta > \theta_{\max}$ , then the structure is potentially unstable, and must be redesigned. For  $0.1 < \theta < \theta_{\max}$ , the interstory drift and element forces need to be computed using the  $P$ -delta effect. The design story drift considering the  $P$ -delta effect,  $\Delta_p$ , can be calculated from

$$\Delta_p = \Delta \frac{1}{1 - \theta} \quad (20.29)$$

The computed values of story drift should not exceed the allowable values described in Table 20.9.

### 20.3.9 Summary: Lateral Deformation of the Structure

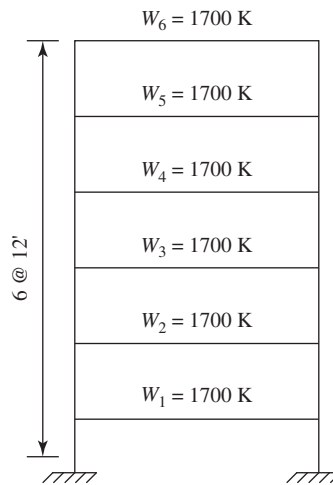
- Step 1.** If the structure satisfies the limitations for the simplified analysis procedure listed in Section 20.3.3, use Eq. 20.24 to determine the story drift.
- Step 2.** For structures that do not satisfy the limitations for the simplified analysis procedure listed in Section 20.3.3, use Eqs. 20.25 to 20.27 to calculate  $\delta_x$ ,  $\delta_{x-1}$ ,  $\Delta$ ,  $\theta$ , and  $\theta_{\max}$ . Check whether the  $P$ -delta effect must be considered, and adjust  $\Delta$  to  $\Delta_p$  using Eq. 20.29 where needed.
- Step 3.** Determine allowable drift from Table 20.9, and compare with the calculated design drift. If calculated drift exceeds the allowable drift, redesign the structure.



**Example 20.3 Equivalent Lateral Procedure**

Determine the design seismic force and seismic shear force for a six-story concrete special moment-resisting frame adult education facility building located in an area of high seismic risk where  $S_s = 1.5 g$  and  $S_1 = 0.6 g$ , on soil class B. The story heights are all 12 ft, and the story weights are all 1700 Kips. Check the lateral deformation of the structure. Building elevation is given in Fig. 20.5. The  $\delta_{xe}$  is obtained from static elastic analysis using the design seismic force and is given as follows:

Floor Level	$\delta_{xe}$
6	1.26
5	0.98
4	0.71
3	0.46
2	0.24
1	0.06



**Figure 20.5** Example 20.3: Building elevation.

**Solution**

- Risk category III,  $I_e = 1.25$  (Table 20.1)  
 $S_s = 1.5 g$ ,  $S_1 = 0.6 g$  (Figs. 20.1 and 20.2)  
 Soil class B; so,:

$$F_a = 1.0, F_v = 1.0 \quad (\text{Table 20.2 and 20.3})$$

$$S_{MS} = 1.5 g, S_{M1} = 0.6 g \quad (\text{Eq. 20.2a and 20.2b})$$

$$S_{DS} = 1.0 g \quad (\text{Eq. 20.1a})$$

$$S_{D1} = 0.4 g \quad (\text{Eq. 20.1b}) = \left(\frac{2}{3} \times 0.6 g\right)$$

SDC is D. (Tables 20.5 and 20.6)

- According to Table 20.7, for special moment-resisting frame, select  $R = 8$ .
- Equation 20.16 is not applicable since  $h_x > 10$  ft. The period of vibration of the structure is calculated according to Eq. 20.15 as follows:

$$T_a = C_T h_n^{3/4} = 0.016 \times (6 \times 12)^{0.9} = 0.75 \text{ s}$$

- Calculate seismic response coefficient as follows, and check for the limits:

$$C_s = \frac{S_{DS}}{R/I_e} = \frac{1.0}{8/1.25} = 0.156$$

$$C_{s,\max} = \frac{S_{DI}}{(R/I_e)T} = \frac{0.4}{(8/1.25)0.74} = 0.083$$

Since  $S_1 = 0.6$  g, Eq. should be used to calculate  $C_{s,\min}$ :

$$C_{s,\min} = \frac{0.5S_1}{(R/I_e)} = \frac{0.5 \times (0.6)}{8/1.25} = 0.047$$

Since  $C_s > C_{s,\max}$ ,  $C_s = 0.083$ .

- The total seismic weight is calculated as follows:

$$W = w_1 + w_2 + w_3 + w_4 + w_5 + w_6 = 6 \times (1700) = 10,200 \text{ K}$$

- Calculate the seismic base using Eq. 20.10:

$$V = C_s W = 0.083 \times 10200 = 846.6 \text{ K} \approx 847 \text{ K}$$

- Calculation of  $F_x$ ,  $V_x$ , and  $M_x$  (Fig. 20.6). Use Eq. 20.17 to calculate the seismic lateral force,  $F_x$ , as shown in the following table. The table also calculates the shear force for each floor level and the overturning moments as described in Eqs. 20.21 and 20.23.

Floor Level	Weight $W_i$ (K)	Height $h_i$ (ft)	$W_i h_j^{k*}$ (K · ft)	$C_{vx}$	Lateral Force, $F_x$ (K)	Shear Force, $V_x$ (K)	Overturning Moment $M_x$ (K · ft)
6	1,700	72	208,905	0.30	254	254	0
5	1,700	60	170,165	0.24	207	461	3,052
4	1,700	48	132,387	0.19	161	622	8,559
3	1,700	36	95,783	0.14	117	739	16,061
2	1,700	24	60,700	0.09	74	813	24,931
1	1,700	12	27,831	0.04	34	847	34,689
0			695,770			847	44,853

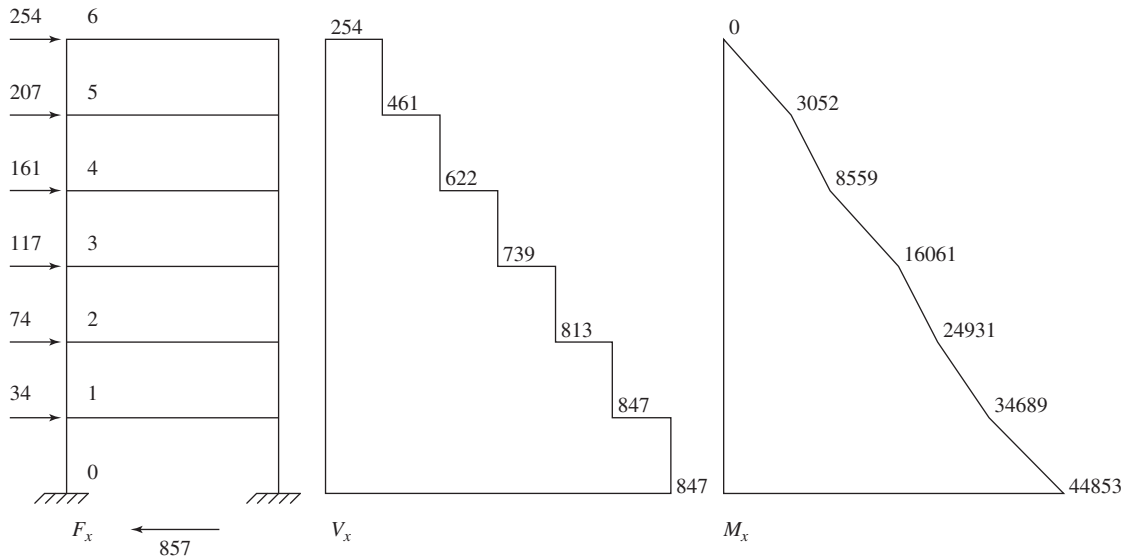
\*To calculate K, use Section 20.3.1. For  $T = 0.75$  s, using linear interpolation  $k = 1.125$ .

- Calculation of drift: According to Table 20.7 for special moment-resisting frame  $C_d = 5.5$ ,

$$I_e = 1.25 \text{ (Table 20.1)}$$

$$h_{sx} = 12 \text{ ft} = 144 \text{ in.}$$

Floor Level	$\delta_{xe}$ (in.)	$\delta_x$ (in.)	$\Delta$ (in.)	$P_x$ (K)	$V_x$ (K)	$\theta$
6	1.26	5.54	1.23	1,700	254	0.013
5	0.98	4.31	1.19	3,400	461	0.014
4	0.71	3.12	1.10	5,100	622	0.014
3	0.46	2.02	0.96	6,800	739	0.014
2	0.24	1.06	0.80	8,500	813	0.013
1	0.06	0.26	0.26	10,200	847	0.005



**Figure 20.6** Example 20.3: Distribution of lateral seismic force,  $F_x$ , base shear,  $V_x$ , and overturning moment,  $M_x$ .

$$\theta = \frac{P_x \Delta I_e}{V_x h_{sx} C_d} \quad \delta = \frac{C_d \delta_{xe}}{I}$$

where

$\theta$  = stability coefficient

$P_x$  = total unfactored vertical design load at and above levels

$$\beta = 1.0$$

$$\theta_{\max} = \frac{0.5}{C_d \beta} = \frac{0.5}{5.5 \times 1.0} = 0.09 > \theta \text{ in every floor level}$$

which is acceptable. (See Eq. 20.28). Also,  $\theta < 0.10$  in every floor level, which means that the  $P$ -delta effect can be disregarded.

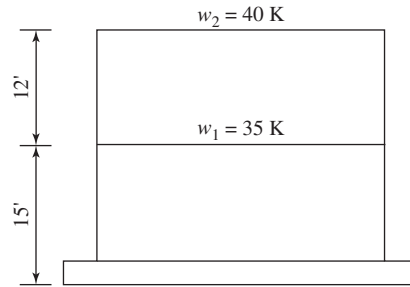
9. Allowable drift, according to the Table 20.9, is  $\Delta_a = 0.015 h_{sx} = 0.015 \times (12 \times 12) = 2.16 \text{ in.} > \Delta$  in every floor level, which is acceptable.

### Example 20.4 Simplified Analysis

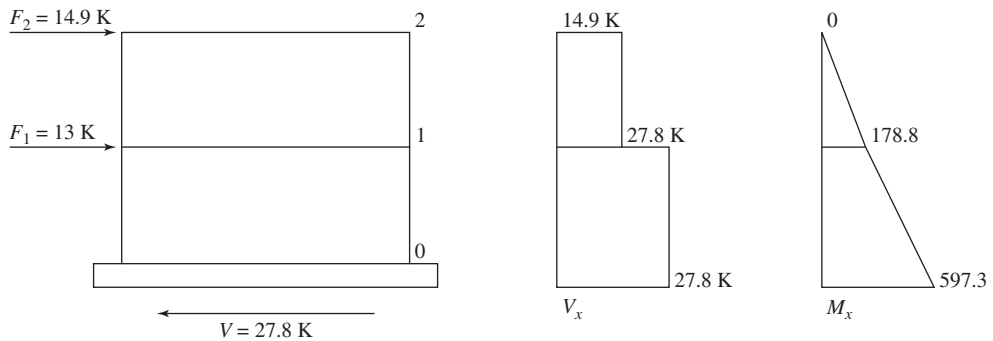
Calculate the seismic base shear for a two-story concrete building assuming that the first-floor weight is  $w_x = 35$  Kips, and the second-floor weight is 40 Kips. The height of the first floor is  $h_x = 15$  ft, and the second floor is 12 ft. The seismic force-resisting system is ordinary reinforced shear wall system. Utilize the value of  $S_{DS}$  from Example 20.1. Check the lateral deformation of the structure.

#### Solution

1. The building is classified as SDC of D, (from Example 20.1) and is two stories in height. This building satisfies the conditions for simplified analysis methodology.
2.  $S_{DS} = 1.35 g$  (Example 20.1).
3. The  $R$  factor is chosen from Table 20.7 based on the seismic force-resisting system of the structure. For ordinary reinforced concrete shear wall,  $R$  is equal to 4.



**Figure 20.7** Example 20.4: Building elevation.



**Figure 20.8** Example 20.4: Distribution of lateral seismic force,  $F_x$ , base shear,  $V_x$ , and overturning moment,  $M_x$ .

- Calculate the total gravity load (Fig. 20.7):  $W = w_1 + w_2 = 35 + 40 = 75$  Kips.
- For two-story building,  $F = 1.1$  as described in Section 20.3.3:

$$V = \frac{FS_{DS}}{R} W = \frac{1.1(3.5)}{4} \times 75 = 27.8 \text{ K} \quad (\text{Eq. 20.19})$$

- Calculate the seismic lateral forces acting at the first and second floors using Eq. 20.20 (Fig. 20.8):

$$F_1 = \frac{1.1S_{DS}}{R} w_1 = \frac{1.1(1.35)}{4} \times 35 = 13 \text{ K} \quad (\text{first floor})$$

$$F_2 = \frac{1.1S_{DS}}{R} w_2 = \frac{1.1(1.35)}{4} \times 40 = 14.9 \text{ K} \quad (\text{second floor})$$

- Calculate the story shear force using Eq. 20.23:

$$V_2 = 14.9 \text{ K} \quad (\text{second floor})$$

$$V_1 = 27.8 \text{ K} \quad (\text{first floor})$$

- Calculate the overturning moment using Eq. 20.24:

$$M_2 = 0 \quad (\text{second floor})$$

$$M_1 = 14.9 \times 12 = 178.8 \text{ kip} \cdot \text{ft} \quad (\text{first floor})$$

$$M_0 = 14 \cdot 9(12 + 15) + 13 \times 15 = 597.3 \text{ kip} \cdot \text{ft} \quad (\text{at the base of the structure})$$

9. Determine the seismic lateral story drift using Eq. 20.24:

$$\Delta_1 = 0.01h_1 = 0.01 \times 15 = 0.15 \text{ ft} = 1.8 \text{ in. (first floor)}$$

$$\Delta_2 = 0.01h_2 = 0.01 \times 12 = 0.12 \text{ ft} = 1.44 \text{ in. (second floor)}$$

Risk category I

Check for allowable drift using Table 20.9:

$$\Delta_a = 0.020h_{sx}$$

where  $h_{sx}$  is the story height below level  $x$  and

$$\Delta_{a1} = 0.020h_1 = 0.020 \times 15 = 0.3 \text{ ft} = 3.6 \text{ in.} > 1.8 \text{ in. (OK) (first floor)}$$

$$\Delta_{a2} = 0.020h_2 = 0.020 \times 12 = 0.24 \text{ ft} = 2.88 \text{ in.} > 1.44 \text{ in. (OK) (second floor)}$$

### Example 20.5 Torsional Effects

Determine the shear forces  $V_1$  and  $V_2$  acting on the shear wall 1 and 2 of the building with the floor plan shown in Fig. 20.9. Assume that the value of story shear,  $V_y$ , is 15 K. Consider torsional effect.

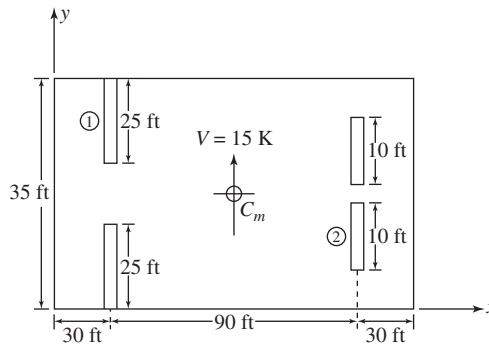


Figure 20.9 Example 20.5: Floor plan.

### Solution

Center of mass is in the centroid of the rigid diaphragm. The center of rigidity  $x$  can be determined as follows (Fig. 20.10):

$$x = \frac{2 \times 25 \times 30 + 2 \times 10 \times 120}{2 \times 25 + 2 \times 20} = 55.7 \text{ ft}$$

$$e_x = 150/2 - 55.7 = 19.3 \text{ ft}$$

For the story shear force  $V_y = 15 \text{ K}$  and eccentricity of 19.3 ft, the torsional moment is

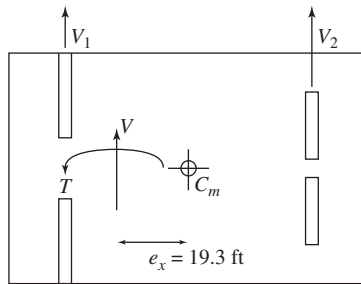
$$T = 15 \times 19.3 = 289.5 \text{ kip} \cdot \text{ft}$$

The shear force acting on the wall is the sum of the shear force due to story shear,  $V_x$ , and shear force due to torsional moment,  $T_y$ .

For wall 1, shear force  $V_1$  is

$$V_1 = \frac{25}{25 + 25 + 10 + 10}(15) = 5.4 \text{ K (due to } V_y)$$

$$V_1 = 2 \times 25 \times 25.7^2 + 2 \times 10 \times 64.3^2 / 289.5(25 \times 25.7) = 1.6 \text{ kip} \cdot \text{ft (due to } T)$$



**Figure 20.10** Example 20.5: Torsional effect.

Therefore,  $V_1 = 5.4 + 1.6 = 7 \text{ K}$ . For wall 2, shear force  $V_2$  is

$$V_2 = \frac{25}{25 + 25 + 10 + 10}(15) = 2.1 \text{ K (due to } V_y)$$

$$V_2 = 2 \times 25 \times 25.7^2 + 2 \times 10 \times 64.3^2 / 289.5(10 \times 64.3) = 1.6 \text{ kip} \cdot \text{ft (due to } T)$$

Therefore,  $V_2 = 2.1 + 1.6 = 3.7 \text{ K}$ .

## 20.4 LOAD COMBINATIONS

A structure should be designed to resist the combined effects of loading cases. For basic load combinations for strength design follow IBC 2012, Section 1605.2:

1.  $1.4(D + F)$
2.  $1.2(D + F) + 1.6(L + H) + 0.5(L_r \text{ or } S \text{ or } R)$
3.  $1.2(D + F) + 1.6(L_r \text{ or } S \text{ or } R) + 1.6H + (f_1L \text{ or } 0.5W)$
4.  $1.2(D + F) + 1.0W + f_1L + 1.6H + 0.5(L_r \text{ or } S \text{ or } R)$
5.  $1.2(D + F) + 1.0E + f_1L + 1.6H + f_2S$
6.  $0.9D + 1.0W + 1.6H$
7.  $0.9(D + F) + 1.0E + 1.6H$

where

$f_1 = 1.0$  for floors in places of public assembly, for live loads in excess of 100 psf, and for parking garages live loads

$f_1 = 0.5$  for other live loads

$f_2 = 0.7$  for roof configurations (such as saw tooth) that do not shed snow off structure

$f_2 = 0.2$  for other roof configurations

$D$  = dead load

$L$  = live load excluding roof live load

$L_r$  = roof live load

$S$  = snow load

$R$  = rain load

$W$  = wind load

$E$  = seismic load effect

$H$  = soil lateral load

Some exceptions are where the effect of  $H$  resists the primary variable load effect, in which case a load factor of 0.9 shall be included with  $H$  where  $H$  is permanent, and  $H$  shall be set to zero for all other conditions.

#### 20.4.1 Calculation of Seismic Load Effect, $E$

Seismic load effects and combinations (ASCE 7-10, Section 12.4) can be determined from the following two conditions:

1. The seismic load effect,  $E$  is calculated from:

$$E = E_h + E_v = \rho Q_E + 0.2S_{DS}D \quad (20.30)$$

where

$Q_E$  = effects of horizontal seismic forces from V

$\rho$  = redundancy factor

$S_{DS}$  = design spectral response acceleration at short periods determined in Section 20.2.2

$D$  = effect of dead load

2. When the effect of gravity and seismic ground motions are counteractive, the seismic load effect is calculated from:

$$E = \rho Q_E - 0.2S_{DS}D \quad (20.31)$$

#### 20.4.2 Redundancy Factor, $\rho$

Redundancy factor can be determined as follows (ASCE 7-10, Section 12.3.4):

1. For structures assigned to seismic design category A, B, or C, the value of the redundancy factor,  $\rho$ , is 1.
2. For structures assigned to seismic design category D, E, or F, the redundancy coefficient  $\rho$  shall be taken equal to 1.3.

#### 20.4.3 Seismic Load Effect, $E_m$

Estimated seismic load effect,  $E_m$ , can be developed in a structure, and is determined from Eq. 20.32.

When effects of gravity and seismic forces are additive, the seismic load effect,  $E_m$ , should be calculated using the following equation:

$$E_m = \Omega_0 Q_E + 0.2S_{DS}D \quad (20.32)$$

where  $\Omega_0$  is the system overstrength factor given in Table 20.7. When the effects of gravity and seismic forces counteract, the seismic load effect,  $E_m$ , should be calculated using the following equation:

$$E_m = \Omega_0 Q_E - 0.2S_{DS}D \quad (20.33)$$

## 20.5 SPECIAL REQUIREMENTS IN DESIGN OF STRUCTURES SUBJECTED TO EARTHQUAKE LOADS

The ACI Code, Sections 4.4.6, 18.1 and 18.2, define six seismic design categories (SDCs) for earthquake-resistant structures. These are A, B, C, D, E, and F. The classification of these zones described in ACI Code, Section R18.1 can be given in three different categories:

1. SDCs D, E, and F indicate high seismic risk zones with strong ground shaking.

2. SDCs C indicates moderate/intermediate seismic risk zones with moderately strong ground shaking.
3. SDCs A and B indicate low seismic risk zones with SDC A corresponding to the lowest seismic hazard zone.

For structures in high seismic risk (SDCs D, E, and F) special requirements in flexural design and detailing are required. Special moment frames (ACI Code, Sections 18.6–18.9) and special structural walls (ACI Code, Section 18.5) should be used as the structural system of a building.

For the structures in moderate seismic risk (SDC C) some special provisions are required for satisfactory intermediate seismic performance (ACI Code, Sections 4.4.6.4, 4.4.6.5.1 and 4.4.6.5.2). Structure can be designed as intermediate moment-frame or intermediate structural-walls systems. Structures from a higher category can also be utilized.

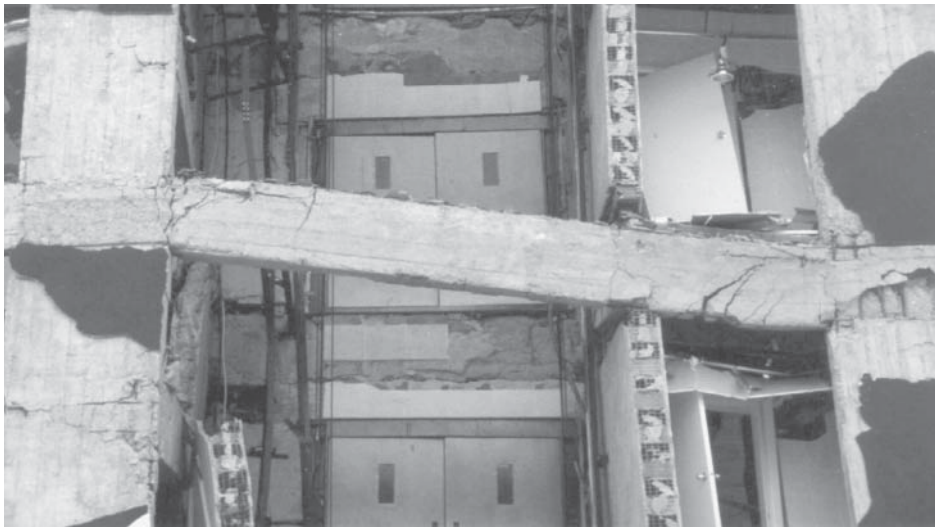
For the structures in low seismic risk (SDC A), no special requirements in flexural design and detailing are required (ACI Code, Section 4.4.6.3). Ordinary moment frames and ordinary structural walls and systems should be utilized as the structural system of a building.

For structure assigned to SDC B, additional requirements apply (ACI Code, Section 4.4.6.4). SDC B structures shall satisfy ACI Code, Chapter 18.

### 20.5.1 Structures in the High Seismic Risk: Special Moment Frames

A special moment frame is a structural system that is designed and detailed to sustain strong earthquakes. Special provisions for designing and detailing are given for

1. Flexural members of special moment frames such as members subjected to only bending.
2. Special moment-frame members subjected to bending and axial load such as columns.
3. Joints of special moment frames.



Strong column–weak girder connection. Courtesy of Murat Saatcioglu and John Gardner

#### 20.5.1.1 Flexural Members of Special Moment Frames

##### 20.5.1.1.1 General Requirements

1. If factored axial compressive force  $P_u < A_g f'_c / 10$ , then the member is considered to be subjected to bending. Area  $A_g$  represents the gross area of the concrete member.



2. Clear span  $l_n \geq 4 \times$  effective depth ( $d$ ).
3. The flexural member width-to-depth ratio,  $b_w/d \geq 0.3$ .
4. Flexural member width ( $b_w$ )  $\geq 10$  in.
5. Width of member  $b_w$  (Fig. 20.11) shall not exceed width of supporting member  $C_2$  + a distance on each side of supporting member equal to the smallest of (a) and (b):
  - a. Width of supporting member,  $C_2$ .
  - b. 0.75 times the overall dimension to supporting member,  $C_1$ .

**20.5.1.1.2 Longitudinal Reinforcement Requirements.** According to the ACI Code, Section 18.6.3.1, the longitudinal reinforcement at any section should satisfy the following (Fig. 20.12):

1. Longitudinal reinforcement for both top and bottom steel ( $A_s$ ) should be in the range defined as follows:

$$\left. \begin{array}{l} \frac{3\sqrt{f'_c}bd}{f_y} \\ \frac{200bd}{f_y} \end{array} \right\} \leq (A_s) \leq 0.025bd \quad (20.34)$$

At least two bars should be provided continuously at both top and bottom. For the statically determined T-sections with flanges in tension, the value of  $b$  in the expression  $3\sqrt{f'_c}bd/f_y$  should be replaced by either  $2b$  (width of web) or the width of the flange, whichever is smaller (ACI Code, Section 9.6.1.2).

2. The positive moment strength at joint face should be greater or equal to  $\frac{1}{2}$  the negative moment strength at that face of the joint (ACI Code, Section 18.6.3.2):

$$\phi M_{n_1}^+ \geq \frac{1}{2} \phi M_{n_1}^- \quad (\text{left joint}) \quad (20.35a)$$

$$\phi M_{n_r}^+ \geq \frac{1}{2} \phi M_{n_r}^- \quad (\text{right joint}) \quad (20.35b)$$

where

$M_{n_1}$  = moment strength at left joint of flexural member

$M_{n_r}$  = moment strength at right joint of flexural member

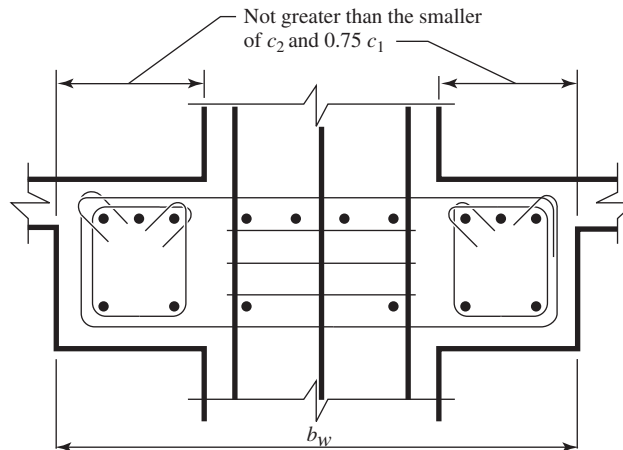
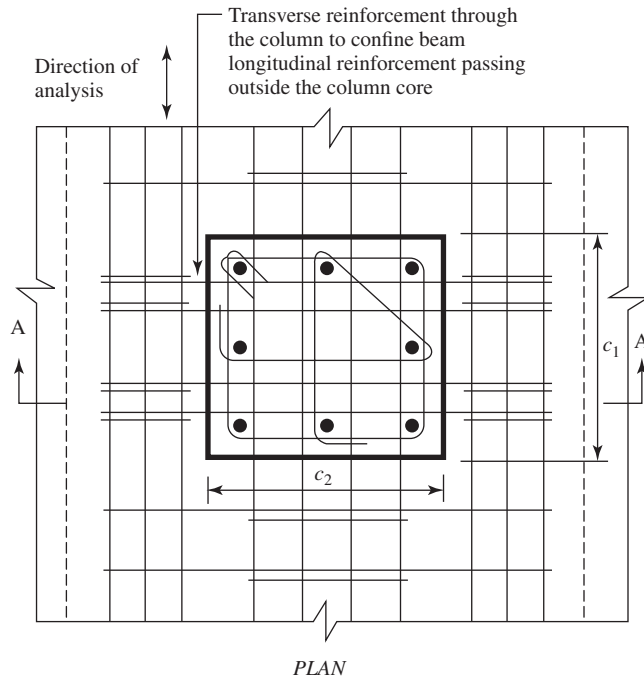
3. Neither the negative nor positive moment strength at any section along the member should be less than  $\frac{1}{4}$  of the maximum moment strength provided at the face of either joint:

$$(\phi M_n^+ \text{ or } \phi M_n^-) \geq \frac{1}{4} (\max \phi M_n \text{ at either joint}) \quad (20.36)$$

4. Anchorage of flexural reinforcement in support can be calculated using the following equation:

$$l_{dh} \geq \begin{cases} \frac{f_y d_b}{65\sqrt{f'_c}} \\ 8d_b \\ 6 \text{ in.} \end{cases} \quad (20.37)$$

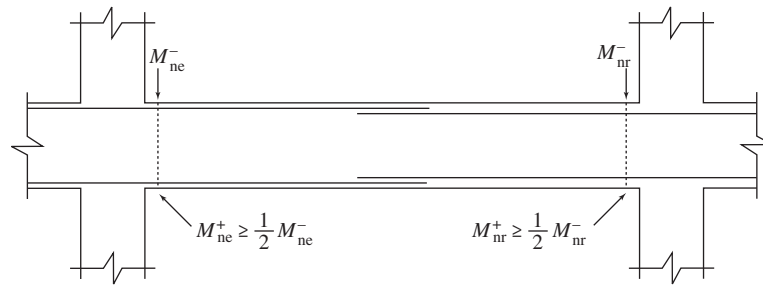
where  $d_b$  is the diameter of longitudinal reinforcement.



Note:  
Transverse reinforcement in column above and below the joint not shown for clarity

SECTION A-A

**Figure 20.11** Maximum effective width of wide beam and required transverse reinforcement. Courtesy of American Concrete Institute [1]



**Figure 20.12** Longitudinal reinforcement requirements.

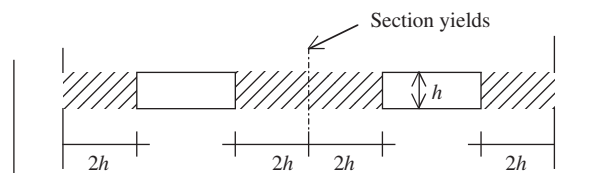
5. Lap splices of flexural reinforcement are permitted only if hoop or spiral reinforcement is provided over the lap length. Hoop or spiral reinforcement spacing should not exceed  $d/4$  or 4 in., whichever is smaller. Lap splices should not be used within a joint, within a distance of twice the member depth from the face of the joint, or at locations of plastic hinges (critical sections).

**20.5.1.1.3 Transverse Reinforcement Requirements.** For the special moment-resisting frame, plastic hinges will form at the ends of flexural members. Those locations should be specially detailed to ensure sufficient ductility of the frame members. Transverse reinforcement gives lateral support for the longitudinal reinforcement and assists concrete to resist shear. It should satisfy the following (ACI Code, Section 18.6.4):

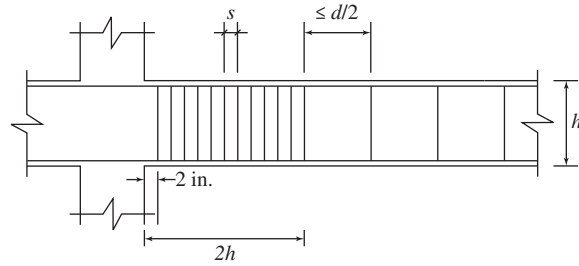
1. Hoops are required over a length equal to twice the member depth from the face of the support at both ends of the flexural member. Also, hoops are required over lengths equal to twice the member depth on both sides of the section where flexural yielding may occur, as shown in Fig. 20.13.
2. The spacing of the hoops,  $s$ , should not exceed the smallest of the following values:
  - a.  $d/4$ .
  - b. Six times the diameter of the smallest primary flexural reinforcing bars excluding longitudinal skin reinforcement.
  - c. 6 in.

The first hoop should be located not more than 2 in. from the face of the support.

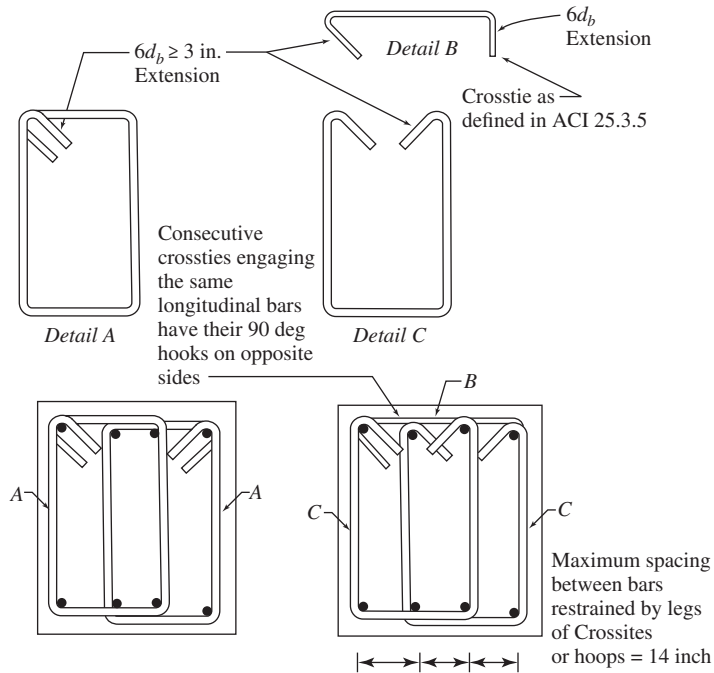
3. Where hoops are not required, stirrups with seismic hooks at both ends should be used. Spacing between stirrups should be less than or equal to  $d/2$ .



**Figure 20.13** Areas of the flexural member where hoops are required. (Note: These areas do not necessarily occur at midspan.)



**Figure 20.14** Transverse reinforcement requirements.

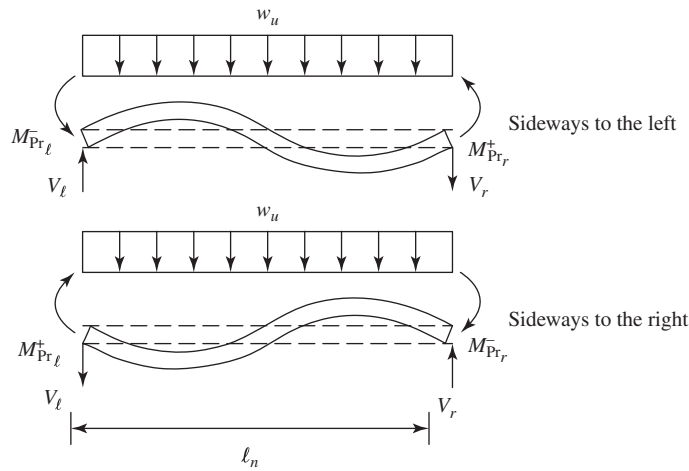


**Figure 20.15** Transverse reinforcement requirements. Courtesy of American Concrete Institute [1]

4. Transverse reinforcement should be designed to resist the design of the shear force (Figs. 20.14 and 20.15). Design of the shear force for flexural members of special moment frames can be determined using the following equation (Fig. 20.16):

$$V_1 = \frac{M_{pr}^- + M_{pr}^+}{l_n} + \frac{w_u l_u}{2} \quad (20.38a)$$

$$V_r = \frac{M_{pr}^- + M_{pr}^+}{l_n} + \frac{w_u l_u}{2} \quad (20.38b)$$



**Figure 20.16** Design shear force. Courtesy of American Concrete Institute [1]

where

- $V_l$  = design shear force at left joint of flexural member
- $V_r$  = design shear force at right joint of flexural member
- $M_{pr}$  = probable moment strength at end of beam, determined as strength of beam with stress in reinforcing steel equal to  $1.25f_y$  and strength reduction factor of  $\phi = 1.0$
- $l_n$  = clear span of flexural member
- $w_u$  = factored distributed load determined by Eq. 20.39

$$w_u = 1.2D + 1.0L + 0.2S \quad (20.39)$$

where

- $D$  = dead load
- $L$  = live load
- $S$  = snow load

Probable moment strength at the end of the beam,  $M_{pr}$ , can be calculated from the following equation:

$$M_{pr} = A_s(1.25f_y) \left( d - \frac{1}{2}a \right) \quad (20.40)$$

where

$$a = \frac{A_s(1.25f_y)}{0.85f'_c b} \quad (20.41)$$

The shear strength of concrete can be taken to be 0 when the earthquake-induced shear force is greater than or equal to 50% of the total shear force and the factored axial compressive force is less than  $A_g f'_c / 20$ , where  $A_g$  is the gross area of the beam.

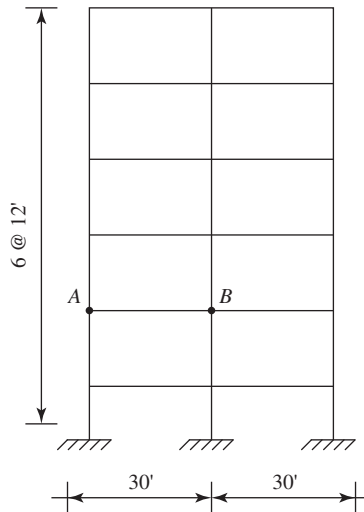
#### **20.5.1.1.4 Summary: Design of the Special Moment-Resisting Frame Members Subjected to Bending.**

**Step 1.** Determine the seismic design category, base shear, lateral seismic force, and seismic shear according to 20.2 and 20.3.

- Step 2.** Calculate the member forces, and use the different load combinations to determine the values of member forces that govern the design (Section 20.4). Design for flexural reinforcement.
- Step 3.** Check whether the frame member is a flexural member and check the general requirements for the special moment frame member according to Section 20.5.1.1.1.
- Step 4.** Check the special requirements for the longitudinal reinforcement according to Section 20.5.1.1.2.
- Step 5.** Design the transverse reinforcement for confinement and shear resistant using Section 20.5.1.1.3.

### Example 20.6

Design a beam  $AB$  on the second floor of a building, as shown in Fig. 20.17. The building is constructed in a region of high seismic risk on soil class B. Additional information are:



**Figure 20.17** Example 20.6: Building elevation.

Material properties:

$$\text{Concrete: } f'_c = 4000 \text{ psi, } w_c = 150 \text{ pcf}$$

$$\text{Steel } f_y = 60,000 \text{ psi}$$

Loads:

$$\text{Live loads} = 40 \text{ psf}$$

$$\text{Super imposed dead load} = 35 \text{ psf}$$

Member dimensions

$$\text{Beams} = 20 \times 24 \text{ in.}$$

$$\text{Columns} = 20 \times 24 \text{ in.}$$

$$\text{Slab thickness} = 7 \text{ in.}$$

$$\text{Effective depth} = 21.5 \text{ in.}$$

**Solution**

1. Seismic design category, base shear, lateral seismic force, and seismic shear are determined in Example 20.3.
2. Load combinations are given as follows:

$$1.4D \quad (I)$$

$$1.2D + 1.6L \quad (II)$$

$$1.2D + 1.0E + f_1 L f_1 = 0.5 \text{ according to Section 20.4} \quad (III)$$

$$0.9D + 1.0E \quad (IV)$$

Redundancy factor,  $\rho$ , cannot be taken less than 1.0. For seismic design category D to F, use  $\rho = 1.3$ . Under special cases,  $\rho$  can be taken as 1.0 (ASCE 7-10, Section 12.3.4.2). Use  $\rho = 1.0$  assuming one of the conditions is met.

Seismic load effect,  $E$ , can be determined using Eqs. 20.30 and 20.31:

$$E = \rho Q_E + 0.2 S_{DS} D = Q_E + 0.2(1.0)D = Q_E + 0.2D$$

$$E = \rho Q_E - 0.2 S_{DS} D = Q_E - 0.2(1.0)D = Q_E - 0.2D$$

Replacing the  $E$  in Eq. III gives:

$$1.4D + 0.5L + Q_E$$

$$D + 0.5L + Q_E$$

Replacing the  $E$  in Eq. IV gives:

$$1.1D + Q_E$$

$$0.7D + Q_E$$

The member forces for the beam  $AB$  on the second floor (Fig. 20.17) are calculated using the software for load analysis, and the values of required flexural strengths are determined using different load combinations, as shown in Table 20.10.

From the previous table 20.10, the most critical loads are chosen and summarized in Table 20.11. Longitudinal reinforcement for the beam is also determined in Table 20.12.

Table 20.12 summarizes the reinforcement used for the beam.

3. General requirements for flexural members of special moment frame are checked as follows:
  - a. Clear span  $\geq 4 \times$  (effective depth)

$$28 \text{ ft} \geq 4 \frac{21.5}{12} = 7.2 \text{ ft (OK)}$$

- b. Width-to-depth ratio  $\geq 0.3$

$$\frac{20}{24} = 0.83 > 0.3 \text{ (OK)}$$

- c. Width = 20 in.  $\geq 10$  in. (OK)

- d. Width  $\leq$  width of supporting member + distance on each side of the supporting member not exceeding smaller of  $C_2$  or  $1.5C_1$

$$20 \text{ in.} \leq C_2 + 2C_2 = 3 \times 24 = 72 \text{ in. (OK)}$$

$$20 \text{ in.} \leq C_2 + 1.5C_1 = 24 + (1.5 \times 26) = 63 \text{ in. (OK)}$$

**Table 20.10** Calculated Member Forces

	Location	Bending Moment (kip · ft)	Shear (Kip)
Load cases			
<i>D</i>	Support	-95	24
	Midspan	65	
<i>L</i>	Support	-22	11
	Midspan	15	
$Q_E$	Support	±290	±25
	Midspan	0	
Load combinations			
1.4 <i>D</i>	Support	-133	33.6
	Midspan	91	
1.2 <i>D</i> + 1.6 <i>L</i>	Support	-149	46.4
	Midspan	102	
1.4 <i>D</i> + 0.5 <i>L</i> + $Q_E$	Support	-434/146 <sup>a</sup>	64.1
	Midspan	98.5	
<i>D</i> + 0.5 <i>L</i> + $Q_E$	Support	-396/184 <sup>a</sup>	54.5
	Midspan	-473	
1.1 <i>D</i> + $Q_E$	Support	-395/186 <sup>a</sup>	51.4
	Midspan	-471.5	
0.7 <i>D</i> + $Q_E$	Support	-357/224 <sup>a</sup>	41.8
	Midspan	45.5	

<sup>a</sup> $Q_E$  has negative and positive value.

**Table 20.11** Calculation of Longitudinal Reinforcement

Location	$M_u$ (kip · ft)	$A_s$ (in. <sup>2</sup> )	Reinforcement	$\phi M_n$ (kip · ft)
Support (top)	-434	5.20	7 no. 8 ( $A_s = 5.53$ in. <sup>2</sup> )	-474
Support (bottom)	224	3.00	6 no. 7 ( $A_s = 3.6$ in. <sup>2</sup> )	323
Midspan	102	1.20	2 no. 7 ( $A_s = 1.2$ in. <sup>2</sup> )	113

**Table 20.12** Summary of Reinforcement

Location	Reinforcement Provided	
	Top	Bottom
Support	7 no. 8 (5.53 in. <sup>2</sup> )	6 no. 7 (3.6 in. <sup>2</sup> )
Midspan	2 no. 8 <sup>a</sup> (1.58 in. <sup>2</sup> )	2 no. 7 (1.2 in. <sup>2</sup> )

<sup>a</sup>Two no. 8 bars are extended from seven no. 8 support bars into the negative moment zone at midspan.



**Table 20.13** Longitudinal Reinforcement Requirements According to the Limits of the Reinforcement

	Reinforcement	Limits		Provided $A_s$ (in. <sup>2</sup> )	$\phi M_n$ (kip · ft)
	$A_s$ (in. <sup>2</sup> )	Min $A_s$ (in. <sup>2</sup> )	Max $A_s$ (in. <sup>2</sup> )		
Support (joint face)	5.53			5.53	-474
	(7 no. 8 at the top) 3.6			3.6	358
Midspan	(6 no. 7 at the bottom) 1.58	1.43	10.75	1.58	-148
	(2 no. 8 at the top) 1.2 <sup>a</sup>			1.8 <sup>a</sup>	168
	(2 no. 7 at the bottom)			(3 no. 7)	

<sup>a</sup>Since  $1.2 \text{ in.}^2 < \min A_s = 1.43 \text{ in.}^2$ , use three no. 7 bars at the bottom. ( $A_s = 1.8 \text{ in.}^2$ )

4. Special requirements for longitudinal reinforcement are

- a. Use Eq. 20.3.4

$$A_s^- \text{ or } A_s^+ \geq \begin{cases} \frac{3\sqrt{f'_c}b_wd}{f_y} = \frac{3\sqrt{4000} \times 20 \times 21.5}{60000} = 1.36 \text{ in.}^2 \\ \frac{200b_wd}{f_y} = \frac{200 \times 20 \times 21.5}{60000} = 1.43 \text{ in.}^2 \end{cases}$$

$$\max A_s = 0.025b_wd = 0.025 \times 20 \times 21.5 = 10.75 \text{ in.}^2$$

Check the reinforcement limits against the required reinforcement, as shown in Table 20.13.

- b. Positive moment strength at joint face  $\geq \frac{1}{2}$  negative moment strength at that face of the joint:

$$M_n^+ = 358 \text{ kip} \cdot \text{ft} \geq \frac{1}{2}M_n^- = \frac{1}{2}(474) = 237 \text{ kip} \cdot \text{ft} \quad (\text{OK})$$

- c. ( $M_n^-$  or  $M_n^+$ ) at any section  $\geq \frac{1}{4}$  (max  $M_n$  at either joint) (ACI Code, Section 18.6.3.2):

$$M_n = 148 \text{ K} \cdot \text{ft} > \frac{1}{4}(474) = 119 \text{ kip} \cdot \text{ft} \quad (\text{OK})$$

Anchorage of flexural reinforcement in exterior column is determined as follows using Eq. 20.37:

For no. 8 bars,

$$l_{dh} = \begin{cases} \frac{60,000 \times 1.0}{65\sqrt{4000}} = 14.6'' \\ 8 \times 1.0 = 8 \text{ in.} \\ 6 \text{ in.} \end{cases}$$

Therefore,  $l_{dh} = 14.6 \text{ in.}$  For no. 7 bars,

$$l_{dh} = \begin{cases} \frac{60,000 \times 0.875}{65\sqrt{4000}} = 12.8 \text{ in.} \\ 8 \times 0.875 = 7 \text{ in.} \\ 6 \text{ in.} \end{cases}$$

Therefore,  $l_{dh} = 12.8 \text{ in.}$

5. Transverse reinforcement is determined as follows:

$$V_e = \frac{(M_{pr}^{\pm})_l + (M_{pr}^{\pm})_r}{l_n} + \frac{w_u l_n}{2}$$

$$M_{pr} = A_s(1.25f_y) \left( d - \frac{a}{2} \right)$$

For six no. 7 bottom bars,

$$a = \frac{A_s(1.25f_y)}{0.85f'_c b} = \frac{3.6(1.25 \times 60)}{0.85 \times 4 \times 20} = 3.97 \text{ in.}$$

$$M_{pr} = A_s(1.25f_y) \left( d - \frac{a}{2} \right) = 3.6(1.25 \times 60) \left( 21.5 - \frac{3.97}{2} \right) = 5269 \text{ kip} \cdot \text{in.} = 439 \text{ kip} \cdot \text{ft}$$

For seven no. 8 bars,

$$a = \frac{A_s(1.25f_y)}{0.85f'_c b} = \frac{5.53(1.25 \times 60)}{0.85 \times 4 \times 20} = 6.1 \text{ in.}$$

$$M_{pr} = A_s(1.25f_y) \left( d - \frac{a}{2} \right) = 5.53(1.25 \times 60) \left( 21.5 - \frac{6.1}{2} \right)$$

$$= 7653 \text{ kip} \cdot \text{in.} = 638 \text{ kip} \cdot \text{ft}$$

$$w_u = 1.2w_D + 0.5w_L = 2.78 \text{ kip/ft}$$

$$V_l = \frac{M_{pr}^- + M_{pr}^+}{l_n} + \frac{w_u l_u}{2} = \frac{638 + 439}{26} + \frac{2.78 \times 26}{2} = 77.6 \text{ K}$$

$$V_r = \frac{M_{pr}^+ + M_{pr}^-}{l_n} + \frac{w_u l_u}{2} = \frac{638 + 439}{26} + \frac{2.78 \times 26}{2} = 5.3 \text{ K}$$

Maximum earthquake-induced shear force is

$$\frac{439 + 638}{26} = 41.4 \text{ K} > \frac{77.6}{2} = 38.8 \text{ K} \Rightarrow V_c = 0$$

$$\phi V_s = V_u - V_c$$

$$V_s = \frac{77.6}{0.75} - 0 = 104 \text{ K}$$

$$V_s = 104 \text{ K} (V_{s,\max}) = 8\sqrt{f'_c} b_w d = 8\sqrt{4000} \times 20 \times 21.5 = 217.6 \text{ K (OK)}$$

(ACI Code, Section 11.4.7.9)

$$V_s = 104 \text{ K} < 4\sqrt{f'_c} b_w d = 4\sqrt{4000} \times 20 \times 21.5 = 109 \text{ K (OK)}$$

(ACI Code, Section 11.4.5.3)

Otherwise maximum stirrups spacing shall be  $d/4$  or less.

Required spacing for no. 3 stirrups is determined as

$$s = \frac{A_s f_y d}{V_s} = \frac{(4 \times 0.11) \times 60 \times 21.5}{104} = 5.5 \text{ in.}$$

Maximum spacing of the hoops within a distance of  $2h = 2 \times 24 = 48 \text{ in.}$  shall not exceed the smallest of

$$\frac{d}{4} = \frac{21.5}{4} = 5.4 \text{ in.}$$

Eight times the diameter of the smallest longitudinal bar  $= 8 \times 0.875 = 7 \text{ in.}$

Twenty-four times the diameter of the hoop bars  $= 24 \times 0.375 = 9 \text{ in.}$  or  $12 \text{ in.}$

Therefore, use 10 no. 3 hoops at each end of the beam at 5 in. center to center with the first hoop located at 2 in. from the face of the support.

At the distance 48 in. from the face of the support, shear strength is

$$V_u = 77.66 - 2.78 \times \frac{48}{12} = 66.48 \text{ K}$$

The shear strength contributed by the concrete is

$$V_c = 2 \times 1 \times \sqrt{4000} \times 20 \times 21.5 = 54.4 \text{ K}$$

$$V_s = \frac{66.54}{0.75} - 54.4 = 34.2 \text{ K}$$

$$S = \frac{A_v f_y d}{V_s} = \frac{4 \times 0.11 \times 60,000 \times 21.5}{34.2} = 16.3 \text{ in.}$$

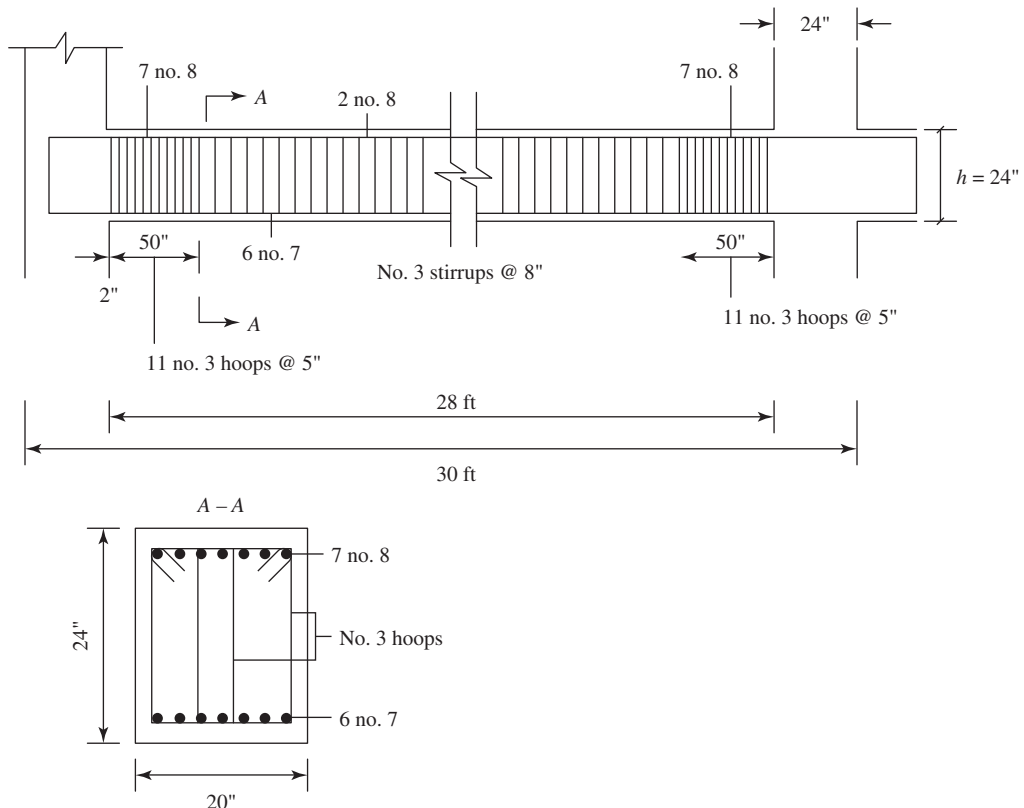
Spacing of the stirrups should not be taken greater than

$$s = \frac{d}{2} = \frac{21.5}{4} = 10.75 \text{ in.}$$

or

$$s = \frac{A_s f_y}{50b} = \frac{(2 \times 0.11) \times 60,000}{50 \times 20} = 26.4 \text{ in.}$$

Therefore, use stirrups with seismic hoops spaced 5 in. center to center starting at 48 in. from the face of the support. Figure 20.18 shows reinforcement detailing.



**Figure 20.18** Example 20.6: Reinforcement detailing.

### 20.5.1.2 Special Moment Frame Members Subjected to Bending and Axial Loads

**20.5.1.2.1 General Requirements.** The requirements of this section apply to columns and other flexural members that carry a factored axial load  $> A_g f'_c / 10$ . These members should satisfy both of the following conditions (ACI Code, Section 18.7.2.1):

1. Shortest cross-section dimension measured on a straight line passing through the geometric centroid  $\geq 12$  in.
2. The ratio of shortest cross-sectional dimension to the perpendicular dimension  $\geq 0.4$ .

**20.5.1.2.2 Longitudinal Reinforcement Requirements.** According to the ACI Code, Section 18.7.3.2, the flexural strengths of columns should satisfy the following:

$$\sum M_{nc} \geq \frac{6}{5} \sum M_{nb} \quad (20.42)$$

where

$\sum M_{nc}$  = sum of nominal flexural strengths of columns framing into joint, evaluated at faces of joint  
 $\sum M_{nb}$  = sum of nominal flexural strengths of the beams framing into joint, evaluated at faces of joint

This approach, called the strong column–weak beam concept (Fig 20.19) ensures that columns will not yield before the beams.

1. The longitudinal reinforcement ratio should satisfy the following (ACI Code, Section 18.7.4.1):

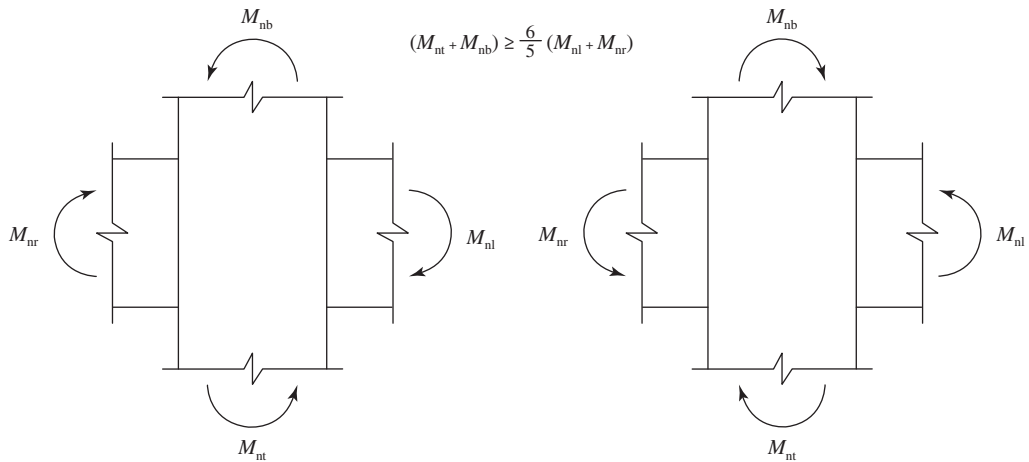
$$0.01 \leq \rho_g \leq 0.06 \quad (20.43)$$

2. In a column with circular hoops, the minimum number of longitudinal bars shall be 6 (ACI Code, Section 18.7.4.2).

**20.5.1.2.3 Transverse Reinforcement Requirements.** Columns should be properly detailed to ensure column ductility in the case of plastic hinge formation and should also have the adequate shear strength to prevent shear failure.



Lack of transverse reinforcement. Courtesy of Murat Saatcioglu and John Gardner



Subscripts l, r, t, and b stand for left support, right support, top of column, and bottom of column, respectively.

**Figure 20.19** Strong column—weak girder concept. Courtesy of Portland Cement Association (Notes on ACI 318)

The following transverse reinforcement requirements need to be provided only over the length  $l_0$  greater or equal to the depth of the member,  $\frac{1}{6}$  clear span, 18 in., from the each joint face and on both sides of any section where yielding is likely to occur (ACI Code, Section 18.7.5.1). The requirements (ACI Code, Section 18.7.5.4) are:

1. Ratio of spiral reinforcement,  $\rho_s$ , should satisfy the following (Fig. 20.20):

$$\rho_s \geq \begin{cases} 0.12 \frac{f'_c}{f_{yh}} \\ 0.45 \left( \frac{A_g}{A_{ch}} - 1 \right) \frac{f'_c}{f_{yh}} \end{cases} \quad (20.44)$$

where

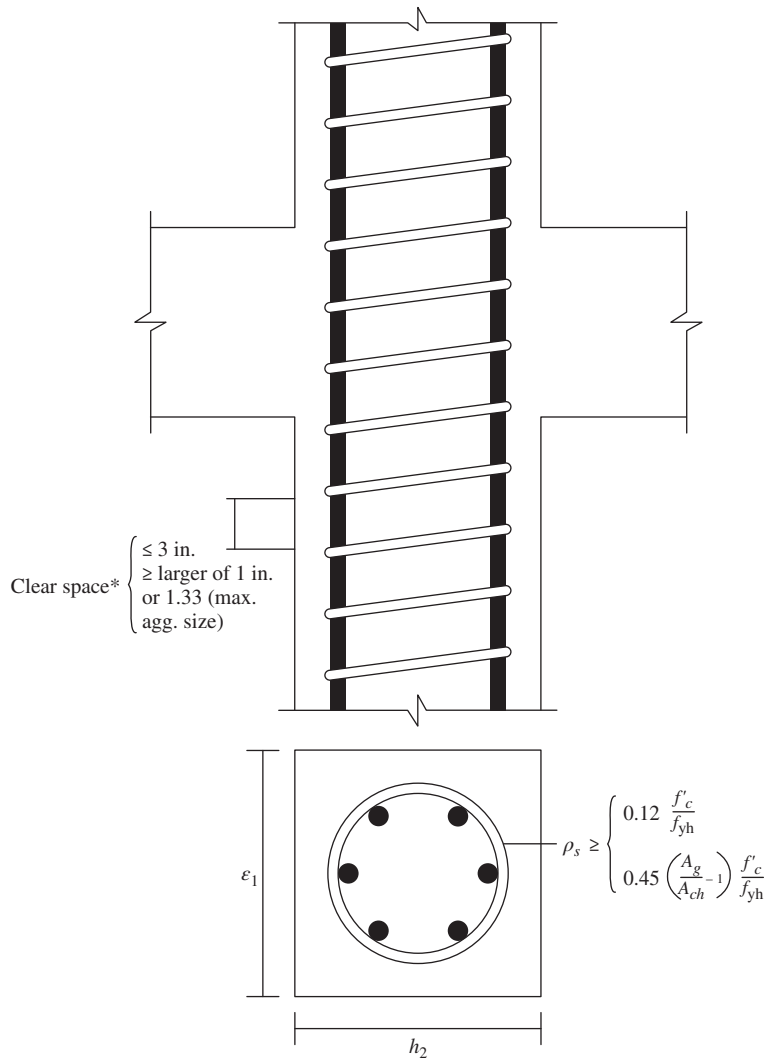
$f_{yh}$  = yield stress of spiral reinforcement

$A_{ch}$  = area of core of spirally reinforced compression member measured to outside diameter of spiral

$A_g$  = gross area of section

2. Total cross-section area of rectangular hoop reinforcement,  $A_{sh}$  (Figure 20.21), should satisfy the following (ACI Code, Section 18.10.7.4):

$$A_{sh} \geq \begin{cases} 0.3 (sb_c) \left( \frac{A_g}{A_{ch}} - 1 \right) \frac{f'_c}{f_{yt}} \\ 0.09 \frac{sb_c f'_c}{f_{yt}} \end{cases} \quad (20.45)$$



**Figure 20.20** Transverse reinforcement requirements for spiral reinforcement. Courtesy of Portland Cement Association (Notes on ACI 318)

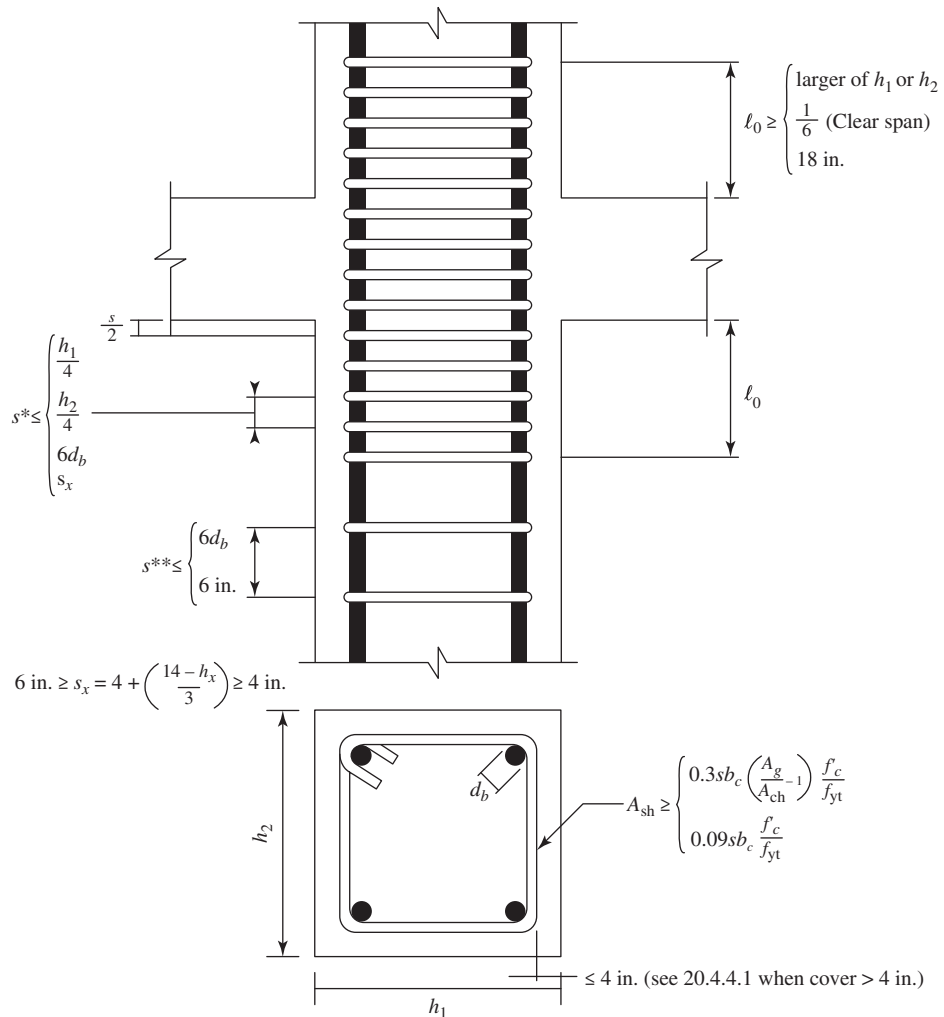
where

$f_{yt}$  = yield stress of hoop reinforcement

$s$  = spacing of transverse reinforcement

$b_c$  = cross-section dimension of column core measured center to center of confining reinforcement

3. If the thickness of the concrete outside the confining transverse reinforcement exceeds 4 in., additional transverse reinforcement should be provided at a spacing  $\leq 12$  in. Concrete cover on additional reinforcement should not exceed 4 in.



**Figure 20.21** Transverse reinforcement requirements for rectangular hoop reinforcement. Courtesy of Portland Cement Association (Notes on ACI 318)

4. Spacing of the transverse reinforcements along the length  $l_0$  should satisfy the following:

$$s \leq \begin{cases} \frac{h}{4} \text{ (} h = \text{minimum member dimension)} \\ 6 \times \text{smallest longitudinal diameter bar} \\ s_0 \end{cases} \quad (20.46)$$

Also,

$$4 \text{ in.} \leq s_0 = 4 + \left( \frac{14 - h_x}{3} \right) \leq 6 \text{ in.} \quad (20.47)$$

where

$s_0$  = longitudinal spacing of transverse reinforcement within the length  $l_0$   
 $h_x$  = maximum horizontal spacing of hoop or crosstie legs on all faces of the column

The remaining member length should be reinforced with the spiral or hoop transverse reinforcement spaced as follows:

$$s \leq \left\{ \begin{array}{l} 6 \times \text{smallest longitudinal diameter bar} \\ 6 \text{ in.} \end{array} \right\} \quad (20.48)$$

Transverse reinforcement should be designed to resist the design shear force. Design shear force for flexural members of special moment frames can be determined using the following equation:

$$V_u = \frac{M_{pr_t} + M_{pr_b}}{l_c} \quad (20.49)$$

where index  $t$  is for top and index  $b$  is for bottom of the column and  $l_c$  is the length of the column.

#### **20.5.1.2.4 Summary: Design of the Special Moment-Resisting Frame Members Subjected to Bending and Axial Force**

- Step 1.** Determine seismic design category, base shear, lateral seismic force, and seismic shear according to 20.2 and 20.3.
- Step 2.** Calculate the member forces and using the different load combinations determine the values of member forces that govern the design. Design the reinforcement.
- Step 3.** Check whether the frame member is a flexural member or whether the member is subjected to the bending and axial force, and check general requirements for the special moment-frame member according to Section 20.5.1.2.1.
- Step 4.** Check the special requirements for the longitudinal reinforcement according to Section 20.5.1.2.2.
- Step 5.** Design the transverse reinforcement for confinement and shear resistant using Section 20.5.1.2.3.

#### **Example 20.7**

Design the edge column on the second floor of a building from Example 20.6.

Given:

#### **First Floor:**

$$P_u = 1022 \text{ K}$$

$$M_{nc} = 580 \text{ kip} \cdot \text{ft}$$

#### **Second Floor:**

$$P_u = 935 \text{ K}$$

$$M_{nc} = 528 \text{ kip} \cdot \text{ft}$$

$$M_{nb} = 723 \text{ kip} \cdot \text{ft}$$



**Solution**

1. The load combinations gave the following results:

$$P_u = 1022 \text{ K} \quad (\text{maximum force at the first floor})$$

$$P_u = 935 \text{ K} \quad (\text{maximum force at the second floor})$$

- 2.

$$P_u = 1022 \text{ K} > \frac{A_g f'_c}{10} = \frac{(24 \times 24)}{10} = 230 \text{ K}$$

The member is subjected to bending and axial loads. General requirements should be checked as follows:

- a. Shortest cross-section dimension = 24 in.  $\geq$  12 in., which is OK.  
 b. The ratio of shortest cross-sectional dimension to the perpendicular dimension,  $\frac{24}{24} = 1 \geq 0.4$ , which is OK.  
 3. Longitudinal reinforcement for the column with  $P_u = 1022 \text{ K}$  is eight no. 8 bars.  
 The reinforcement ratio is  $\rho_g = 0.011 < 0.06$ , which is OK, and  $> 0.01$ , which is also OK.

$$\sum M_{nc} \geq \frac{6}{5} \sum M_{nb}$$

For  $P_u = 1022 \text{ K}$ ,  $M_n = 580 \text{ kip} \cdot \text{ft}$ . For  $P_u = 935 \text{ K}$ ,  $M_n = 528 \text{ kip} \cdot \text{ft}$ . A minimum nominal flexural strength of the beam at the joint including the slab reinforcement is  $M_n = 723 \text{ kip} \cdot \text{ft}$ .

$$\sum M_{nc} = 580 + 528 = 1108 \text{ kip} \cdot \text{ft}$$

$$\sum M_{nb} = 723 \text{ kip} \cdot \text{ft}$$

$$\sum M_{nc} = 1108 \text{ kip} \cdot \text{ft} \geq \frac{6}{5} \sum M_{nb} = \frac{6}{5} 723 = 868 \text{ kip} \cdot \text{ft} \quad (\text{OK})$$

4. Length  $l_0$  is determined as follows:

$$l_0 \geq \begin{cases} \text{depth of the member} = 24 \text{ in.} \\ \frac{1}{6} \text{ clear height} = \frac{1}{6} (12 \times 12) = 24 \text{ in.} \\ 18 \text{ in.} \end{cases}$$

Choose  $l_0 = 24 \text{ in.}$

$$\text{From Eq. 20.46, spacings} \leq \begin{cases} \frac{h}{4} = \frac{24}{4} = 6 \text{ in.} \\ 6 \times \text{Smallest longitudinal diameter bar} = 6 \times 1.0 = 6 \text{ in.} \\ s_0 = 4 + \left( \frac{14 - 11}{3} \right) = 5 \text{ in.} \end{cases}$$

Therefore,  $s = 5 \text{ in.}$

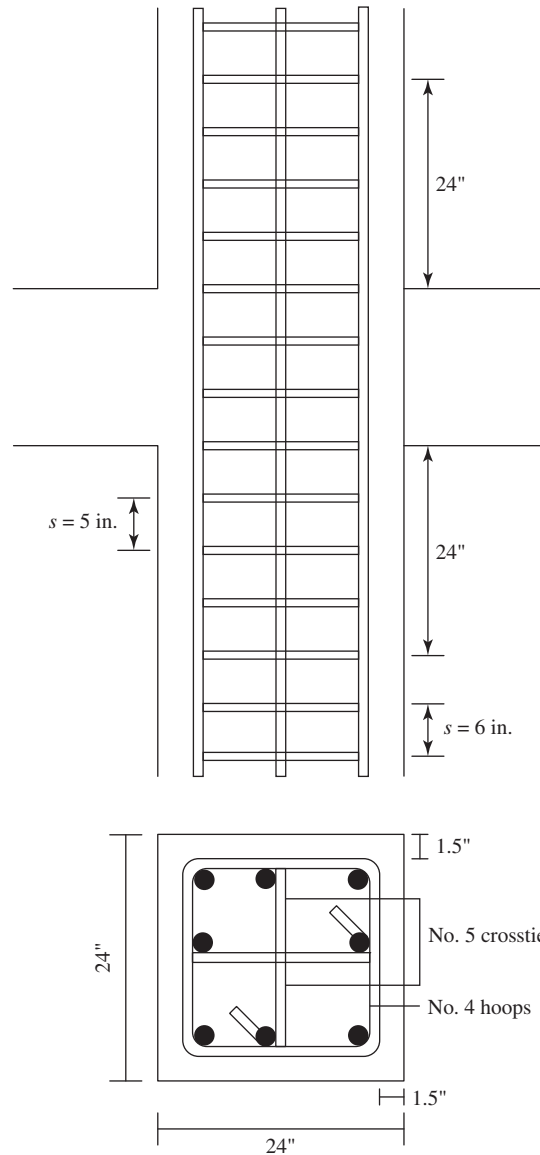
Required cross-section area of reinforcement is

$$A_{sh} \geq \begin{cases} 0.3 \left( \frac{s b_c f'_c}{f_{yt}} \right) \left( \frac{A_g}{A_{ch}} - 1 \right) = 0.3 \left( \frac{5 \times 20.5 \times 4}{60} \right) \left( \frac{576}{441} - 1 \right) = 0.63 \text{ in.}^2 \\ 0.09 \frac{s b_c f'_c}{f_{yt}} = 0.09 \frac{5 \times 20.5 \times 4}{60} = 0.62 \text{ in.}^2 \end{cases}$$

Choose no. 4 hoops and no. 5 crossties:

$$A_{sh} = 2 \times 0.2 + 0.31 = 0.71 \text{ in.}^2 > 0.63 \text{ in.}^2$$

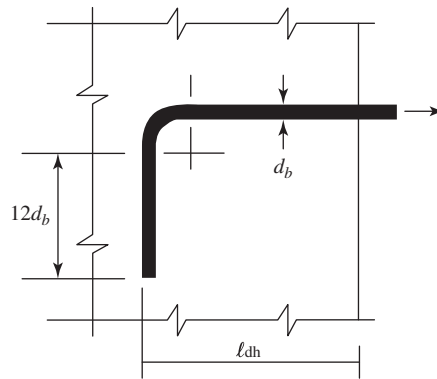
Detailing of the reinforcement can be found in Fig. 20.22.



**Figure 20.22** Example 20.7: Reinforcement detailing.

**20.5.1.3 Joints of Special Moment-Resisting Frame.** Joint of special moment-resisting frame should be detailed according to ACI Code, Section 18.8, as follows:

**20.5.1.3.1 Longitudinal Reinforcement Requirements.** The development length  $l_{dh}$  for a bar with a standard  $90^\circ$  hook using normal-weight concrete, for bar size no. 3 through no. 11, should



**Figure 20.23** Standard 90° hooks. Courtesy of American Concrete Institute [1]

be determined according to the following (Fig. 20.23):

$$l_{dh} \geq \begin{cases} \frac{f_y d_b}{65 \sqrt{f'_c}} \\ 8d_b \\ 6 \text{ in.} \end{cases} \quad (20.50)$$

where  $d_b$  is the diameter of longitudinal reinforcement. The 90° hook shall be located within the confine core of the column.

The development length,  $l_d$ , for a straight bar for bar sizes no. 3 through no. 11 should not be less than the larger of:

1.  $2.5 l_{dh}$  if the depth of the concrete cast in one lift beneath the bar does not exceed 12 in.
2.  $3.5 l_{dh}$  if the depth of the concrete cast in one lift beneath the bar exceeds 12 in.

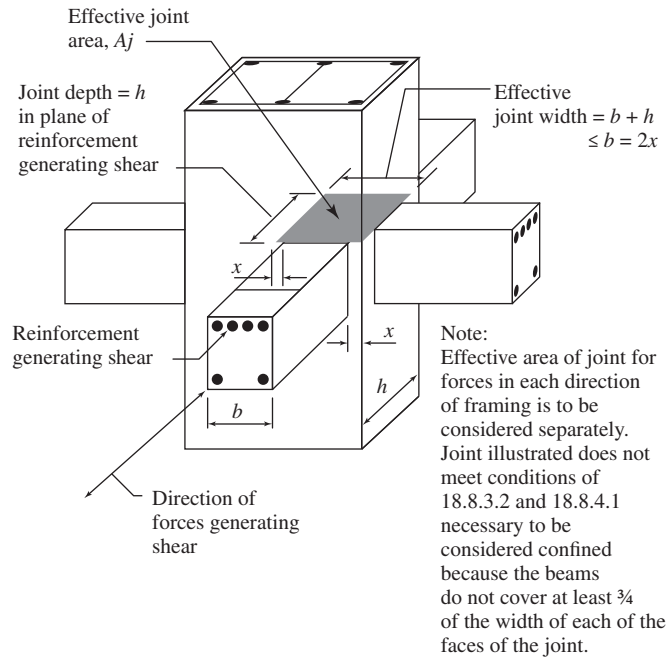
When the longitudinal reinforcement passes through the beam column joint, the column dimension parallel to the beam reinforcement should not be less than 20 times the diameter of the largest longitudinal beam bar for normal-weight concrete. For lightweight concrete, this dimension should not be less than 26 times the bar diameter.

**20.5.1.3.2 Shear Strength Requirements.** The nominal shear strength of the joint for normal-weight concrete should not exceed the following:

1.  $20 \sqrt{f'_c A_j}$  for joints confined by beams on all four faces.
2.  $15 \sqrt{f'_c A_j}$  for joints confined by beams on three faces or on two opposite faces.
3.  $20 \sqrt{f'_c A_j}$  for all other cases.

where  $A_j$  is the effective area, as shown in Fig. 20.24.

A beam that frames into a face is considered to provide confinement to the joint, if it covers at least three quarters of the face of the joint. Extension of beams at least one overall



**Figure 20.24** Effective joint area ( $A_j$ ). Courtesy of American Concrete Institute

beam depth  $h$  beyond the joint face are permitted to be considered adequate for confirming that joint face.

$$A_j = \text{joint depth} \times \text{Effective depth}$$

$$\text{Joint depth} = h \text{ (overall depth of column)}$$

Effective joint width = overall width of column except where a beam frames into a wider column.

$$\text{Effective joint width} \leq \left\{ \begin{array}{l} \text{(a) Beam width + joint depth} \\ \text{(b) Twice the smaller perpendicular distance} \\ \text{from longitudinal axis of beam to column side} \end{array} \right\}$$



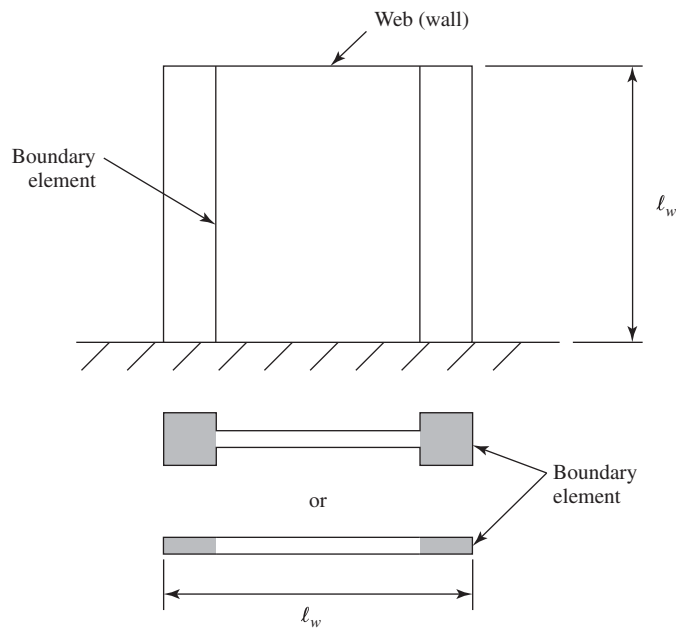
Column-girder connection (joint). Courtesy of Murat Saatcioglu and John Gardner

### 20.5.2 Structures at High Seismic Risk: Special Reinforced Concrete Structural Walls and Coupling Beams (ACI Code, Section 18.10)

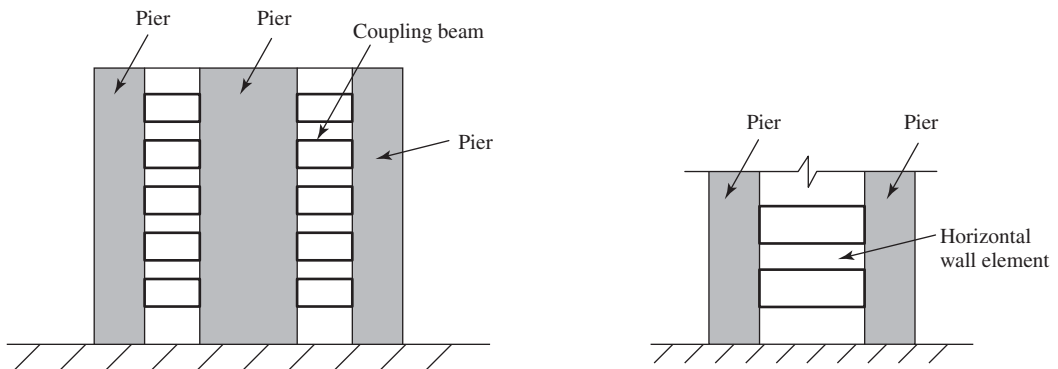
A wall system is a structural system that provides support for all gravity loads and all lateral loads applied to the structure. A structural wall system is much stiffer than a frame system and its performance during an earthquake is better than the performance of the frame system.

A structural wall should be properly designed to sustain all loads acting on it. Boundary elements of structural walls are the areas around the structural wall edges, as shown in Fig. 20.25, that are strengthened by the longitudinal and transverse reinforcement. Boundary elements increase the rigidity and strength of wall panels. The web reinforcement is anchored into the boundary elements.

Figure 20.26 shows the elements of the wall with openings. The vertical wall segment bounded by two openings is called a pier. A horizontal wall section between the openings is called



**Figure 20.25** Boundary elements of structural wall.



**Figure 20.26** Elements of the wall with openings.

a horizontal wall segment. When the openings are aligned vertically over the building height, the horizontal wall segments between the openings are called coupling beams.



Shear wall after an earthquake. Courtesy of Murat Saatcioglu and John Gardner

In the regions of high seismic risk, structural walls that meet special reinforcement requirements should be used. The ACI Code, Section 18.10.1, gives provisions for the design and detailing of structural walls. These are described in the following sections.

**20.5.2.1 Reinforcement Requirements.** Shear reinforcement should be provided in two orthogonal directions in the plane of the wall (ACI Code, Section 18.10.2.1). The minimum reinforcement ratio for both longitudinal and transverse directions can be determined as follows:

1. If the design shear  $V_u > A_{cv}\lambda\sqrt{f'_c}$ , the distributed web reinforcement ratios,  $\rho_l$  and  $\rho_t$ , should not be less than 0.0025.

$$\rho_l = \frac{A_{sv}}{A_{cv}} = \rho_t \geq 0.0025 \quad (20.51)$$

where

$\rho_t$  = ratio of area of distributed transverse reinforcement parallel to plane of  $A_{cv}$  to gross concrete area perpendicular to that reinforcement (Fig. 20.27)

$\rho_l$  = ratio of area of distributed longitudinal reinforcement perpendicular to that reinforcement of  $A_{cv}$  to gross concrete area  $A_{cv}$  (Fig. 20.27)

$A_{cv}$  = gross area of concrete section (product of thickness and length of section in direction of shear force)

$A_{sv}$  = projection on  $A_{cv}$  of area of shear reinforcement crossing the plane of  $A_{cv}$

$\lambda$  = factor for lightweight aggregate concrete

2. If the design shear  $V_u > A_{cv}\lambda\sqrt{f'_c}$ , the minimum reinforcement for ordinary structural walls can be utilized:

Minimum vertical reinforcement ratio,  $\rho_l = 0.0012$  for no. 5 bars and smaller  
 $= 0.0015$  for no. 6 bars and larger

Minimum horizontal reinforcement ratio,  $\rho_t = 0.0020$  for no. 5 bars and smaller  
 $= 0.0025$  for no. 6 bars and larger

The spacing of the reinforcement can be calculated as follows:

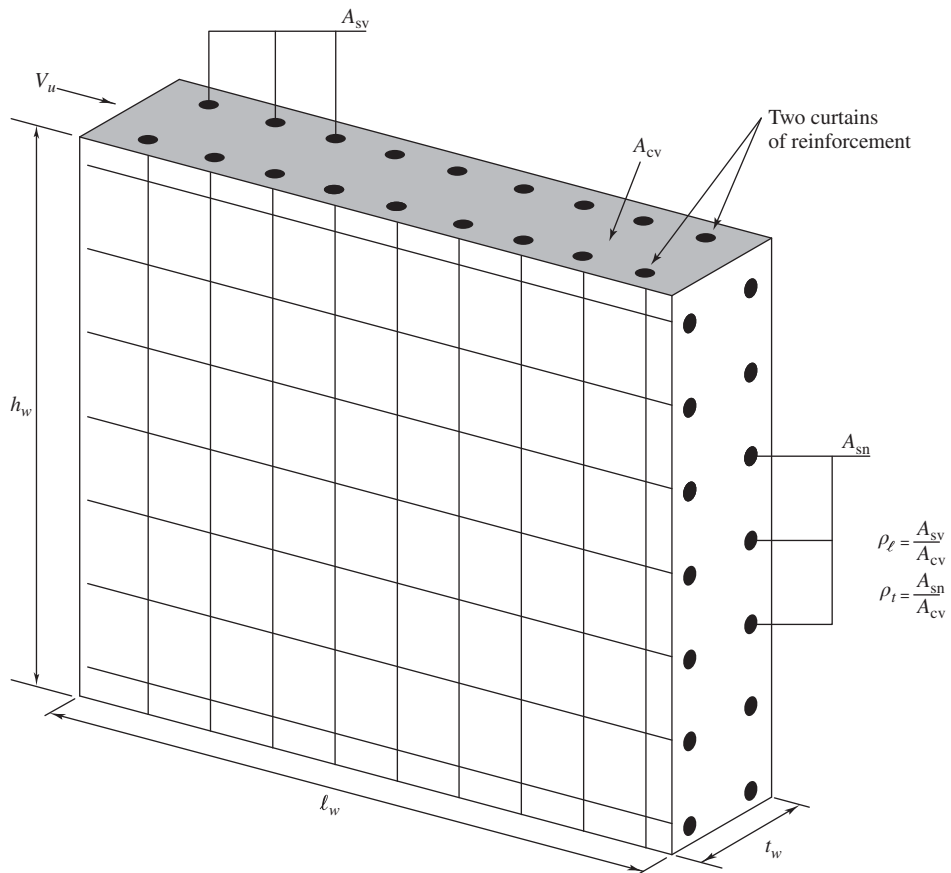
$$s = 2A_s^1/A_s \quad \text{required per(foot of wall)}$$

where  $A_s^1$  is the area of one bar (Fig. 20.27).

Maximum spacing of reinforcement is 18 in. each way according to ACI Code, Section 18.10.2.1.

If the in-plane factored shear force assigned to the wall exceeds  $2A_{cv}\lambda\sqrt{f'_c}$ , at least two curtains of reinforcement should be provided, as shown in Fig. 20.27.

All continuous reinforcement in structural walls should be anchored and spliced as reinforcement in tension for special moment frame (ACI Code, Section 18.10.2.3).



**Figure 20.27** Reinforcement requirements. (where  $A_{sv}$  = longitudinal area of steel,  $A_{sn}$  = transverse area of steel).

**20.5.2.2 Shear Strength Requirements (ACI Code, Section 18.10.4).** The shear strength of the structural wall is adequate if the following condition is satisfied:

$$V_u \leq \phi V_n \quad (20.52)$$

where

$$\begin{aligned} V_u &= \text{factored shear force} \\ V_n &= \text{nominal shear strength} \\ \phi &= \text{strength reduction factor} \end{aligned}$$

According to the ACI Code, Section 21.2.4, the strength reduction factor for shear will be 0.6 for any structural member designed to resist earthquake effects if its nominal shear strength is less than the shear corresponding to the development of the nominal flexural strength of the member. For all other conditions the reduction factor for shear will be 0.75.

The ACI Code, Section 18.10.4, defines the nominal shear strength of structural walls as follows:

$$V_n = A_{cv}(\alpha_c \lambda \sqrt{f'_c} + \rho_t f_y) \quad (20.53)$$

where

$$\begin{aligned} \alpha_c &= 3.0 \text{ for } h_w/l_w \leq 1.5 \\ &= 2.0 \text{ for } h_w/l_w \geq 2.0 \\ &= \text{linear interpolation between 3.0 and 2.0 for } h_w/l_w \text{ between 1.5 and 2.0} \end{aligned}$$

where

$$\begin{aligned} h_w &= \text{height of wall} \\ l_w &= \text{length of wall} \end{aligned}$$

For the walls with openings, the value of  $h_w/l_w$  shall be the larger of the ratios for the entire wall and the segment of wall considered. This ensures that the assigned unit strength of any segment of a wall is not larger than the unit strength for the whole wall.

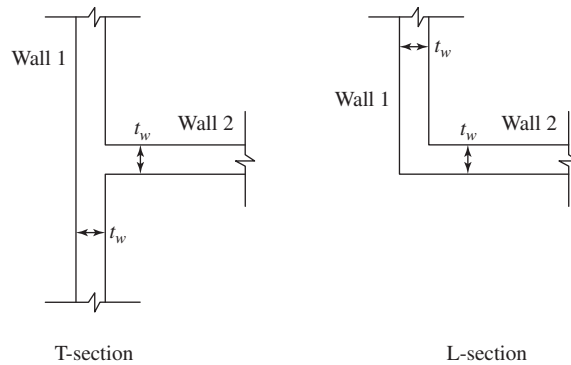
If the ratio  $h_w/l_w \leq 2$ , reinforcement ratio  $\rho_v$  should not be less than  $\rho_n$ .

For the walls with openings, the nominal shear strength,  $V_n$ , for vertical and horizontal walls segments should satisfy the following:

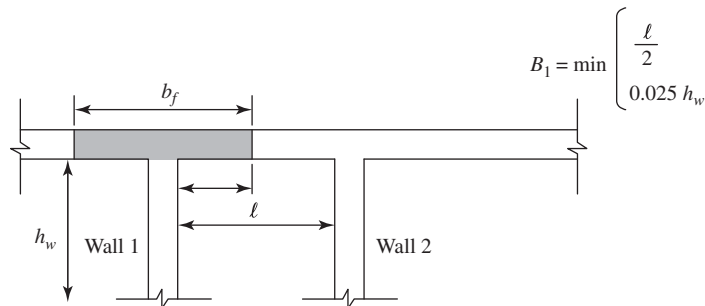
1. If the factored shear force is resisted by several piers, the nominal shear strength,  $V_n$ , for all wall segments should be  $\leq 8A_{cv}\sqrt{f'_c}$ , where  $A_{cv}$  is the total cross-section area of the walls (piers) and  $V_n \leq 10A_{cv}\sqrt{f'_c}$ , where  $A_{cp}$  is the cross-section area of the individual pier considered.
2. Nominal shear strength of a horizontal wall segment and coupling beams,  $V_n$ , should be  $\leq 10A_{cv}\sqrt{f'_c}$ , where  $A_{cw}$  is the cross-section area of the horizontal wall segment or coupling beam.

**20.5.2.3 Design for Flexure and Axial Loads.** Flexural strength of walls should be determined according to the procedure used for columns subjected to flexure and axial loads (ACI Code, Section 18.10.5). The reinforcement in the whole cross section of the wall, including boundary elements and web, should be included in calculations of the capacity of the wall. Openings in walls should also be considered.





**Figure 20.28** Shapes of the wall flanges.



**Figure 20.29** Effective flange width,  $b_f$ .

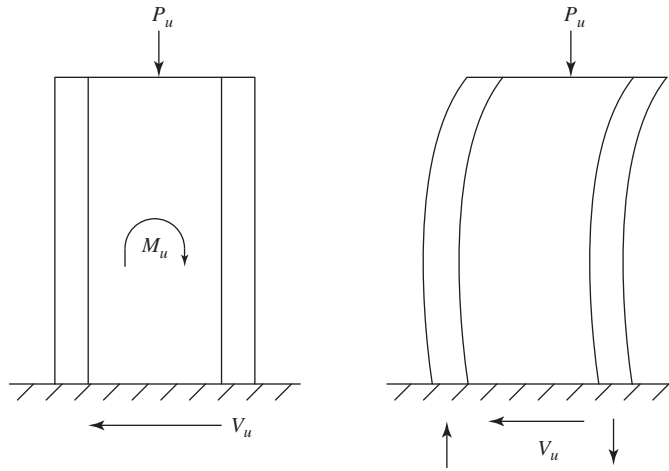
Where the wall sections intersect to form L-sections, T-sections, or other cross-section shapes of the flanges (as shown in Fig. 20.28), the design needs to be considered. Flange width should be determined as follows.

Effective flange width from the face of the web should extend a distance equal to or smaller than  $\frac{1}{2}$  the distance to an adjacent wall web or 25% of the total wall height (Fig. 20.29) (ACI Code, Section 18.10.5.2).

**20.5.2.4 Special Boundary Elements of Special Reinforced Structural Walls.** During an earthquake, a structural wall behaves as a cantilever beam (Fig. 20.30). Boundary elements can be very heavily loaded due to earthquake loads. A plastic hinge can form at the base of the wall, which requires special reinforcement detailing to provide necessary strength and ductility of the structural wall. According to the ACI Code, Section 18.10.6.1, there are two design approaches for evaluating the detailing requirements of the wall boundary element. These are defined as follows:

1. Displacement-based design (ACI Code, Section 18.10.6.2). For the walls or wall piers that are effectively continuous from the base of the structure to the top of the wall, design to have a single critical section for flexure, and axial load compression zones should be reinforced with special boundary elements if

$$c \geq \frac{l_w}{600(1.5\delta_u/h_w)} \quad (20.54)$$



**Figure 20.30** Deformation of wall due to earthquake loads.

where  $\delta_u/h_w \geq 0.007$

$c$  = distance from extreme compression fiber to neutral axis, calculated for factored axial force and nominal moment strength

$l_w$  = length of wall in direction of shear force

$\delta_u$  = design displacement

The special boundary reinforcement should extend vertically from a critical section a distance (Fig. 20.30) given as

$$\geq \begin{cases} l_w \\ M_u \\ 4V_u \end{cases} \quad (20.55)$$

2. Shear-based design (ACI Code, Section 18.10.6.3). Structural walls not designed to the displacement-based approach shall have special boundary elements at boundaries and edges around openings of the structural wall. A special boundary element should be provided where the maximum extreme fiber compressive stress due to factored forces, including earthquake effects, exceeds  $0.2f'_c$ . The boundary elements may be discontinued when the compressive stress becomes less than  $0.15f'_c$ .

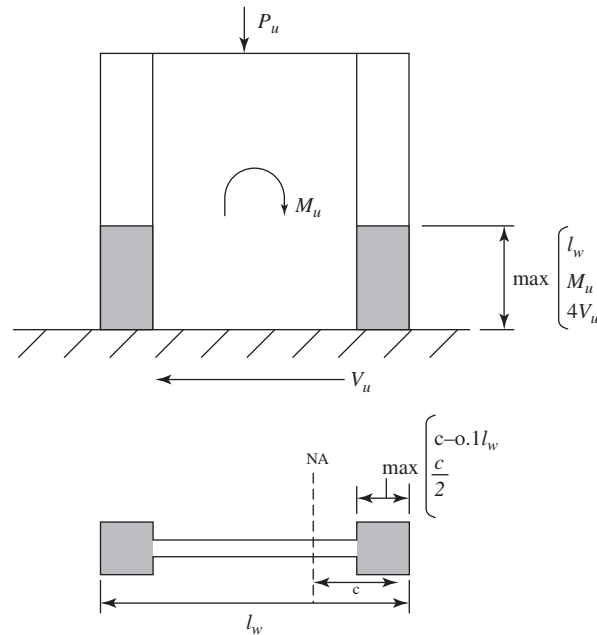
Detailing of the special boundary elements should satisfy the following:

1. Extend horizontally from the extreme compression fiber a distance (Fig. 20.31)

$$\geq \begin{cases} c - 0.1l_w \\ \frac{c}{2} \end{cases}$$

where  $c$  is the largest neutral axis depth calculated for the factored axial force and nominal moment strength consistent with  $\delta_u$ .

2. Transverse reinforcement should be designed by the provisions given for the special moment-frame members subjected to bending and axial forces (Fig. 20.32).



**Figure 20.31** Area where special reinforcement requirements should be provided.

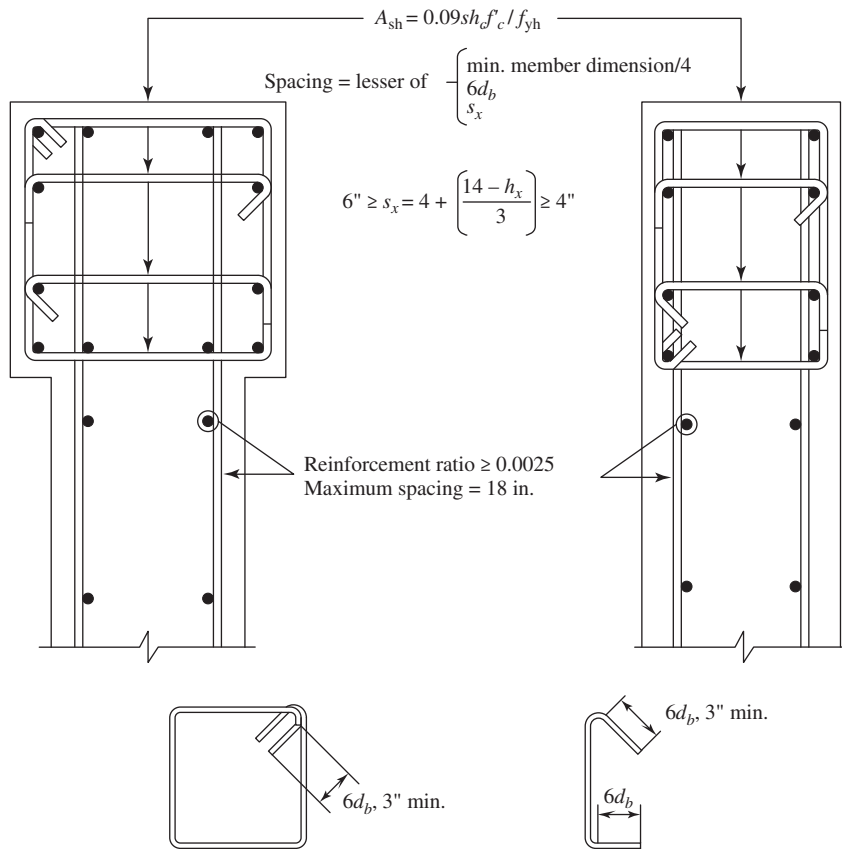
**20.5.2.5 Coupling Beams.** The coupling beam is the structural element that rigidly connects two walls. In a properly designed earthquake-resistant coupled wall system, the coupled beams should yield first, before the base of the wall where the bending moment has the highest value. Also, the beam should have significant ductility and dissipate the energy through the inelastic deformation.

According to the ACI Code, Section 18.10.7, the coupled beams should be designed as follows:

1. If  $l_n/h \geq 4$ , where  $l_n$  is the length and  $h$  is the height of the coupled beam, design the coupled beam to satisfy requirements given for flexural members of special moment frame (ACI Code, Section 18.10.7.1).
2. If  $l_n/h < 2$ , the beam should be reinforced with two intersecting groups of diagonally placed bars symmetrical about the midspan. The diagonal bars are also required for coupling beam with aspect ratio  $l_n/h < 2$  and  $V_u \leq 4\lambda\sqrt{f'_c}A_{cw}$ , where  $A_{cw}$  is the area of concrete section, resisting shear, of individual pier or horizontal wall segment (ACI Code, Section 18.10.7.2).

Two confinement options are described in ACI 318, as shown in Fig. 20.33. According to ACI Code, Section 18.10.7.4(c), each diagonal element consists of a cage of longitudinal and transverse reinforcement, as shown in Fig. 20.33a. Each cage contains at least four diagonal bars and confines a concrete core. The requirement on side dimensions of the cage and its core is to provide adequate toughness and stability to the core section when the bars are loaded beyond yielding. The diagonal bar should be embedded into the wall not less than 1.25 times the development length for  $f_y$  in tension.

ACI Code, Section 18.10.7.4 describes a second option for confinement of the diagonals as shown in Fig. 20.33b. This second option is to confine the entire beam cross section instead of confining the individual diagonals. This option can considerably simplify field placement for hoops, which can be challenging where diagonal bars intersect each other or the entire wall boundary.



**Figure 20.32** Reinforcement details for special boundary elements. Courtesy of Portland Cement Association (Notes on ACI 318)

Nominal shear strength can be determined using the following equation:

$$V_n = 2A_{vd}f_y \sin \alpha \leq 10\sqrt{f'_c}A_{cw} \quad (20.56)$$

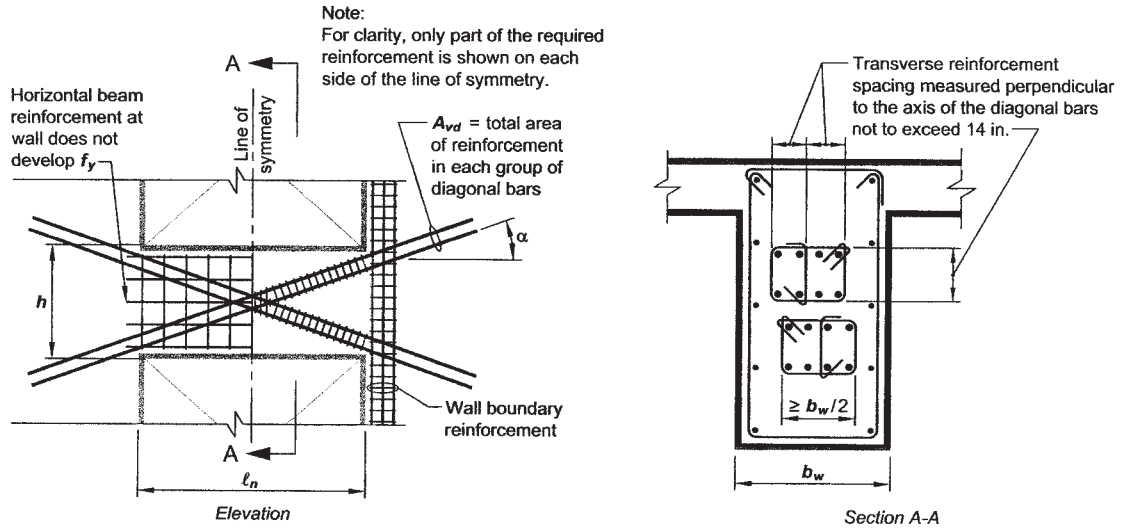
where

$A_{vd}$  = total area of reinforcement in each group of diagonal bars in diagonally reinforced coupling beam

$\alpha$  = angle between diagonal reinforcement and longitudinal axis of diagonally reinforced coupling beam

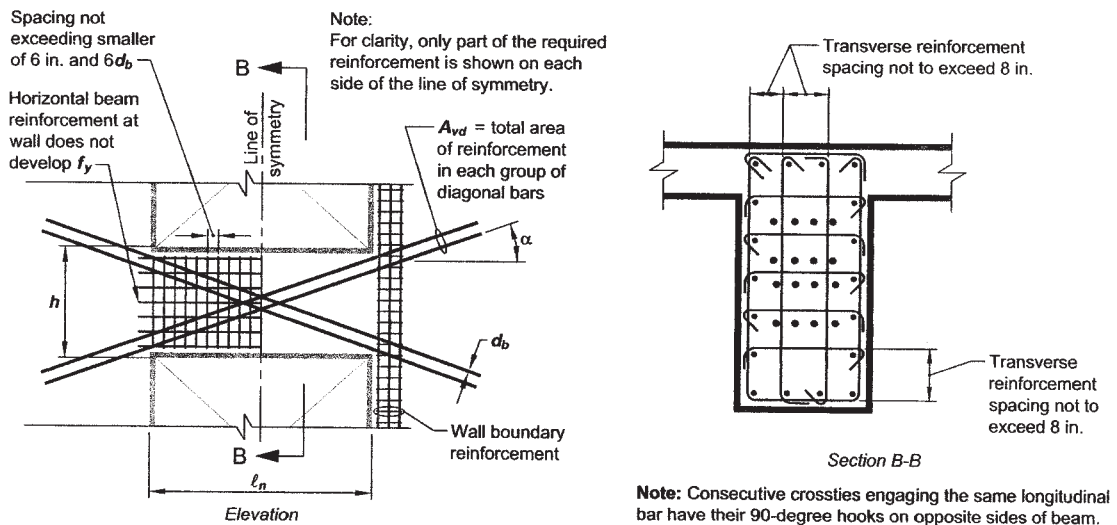
Transverse reinforcement for each group of diagonally placed bars should be designed as transverse reinforcement for the members of a special moment frame subjected to bending and axial force.

Detailing of coupling beam reinforcement should be in accordance with Fig. 20.33.



(a) Confinement of individual diagonals.

**Note:** For clarity in the elevation view, only part of the total required reinforcement is shown on each side of the line of symmetry.



(b) Full confinement of diagonally reinforced concrete beam section.

**Figure 20.33** Reinforced detailing for coupling beams with diagonally oriented reinforcement. Wall boundary reinforcement is shown on one side only for clarity. Courtesy of American Concrete Institute [1]

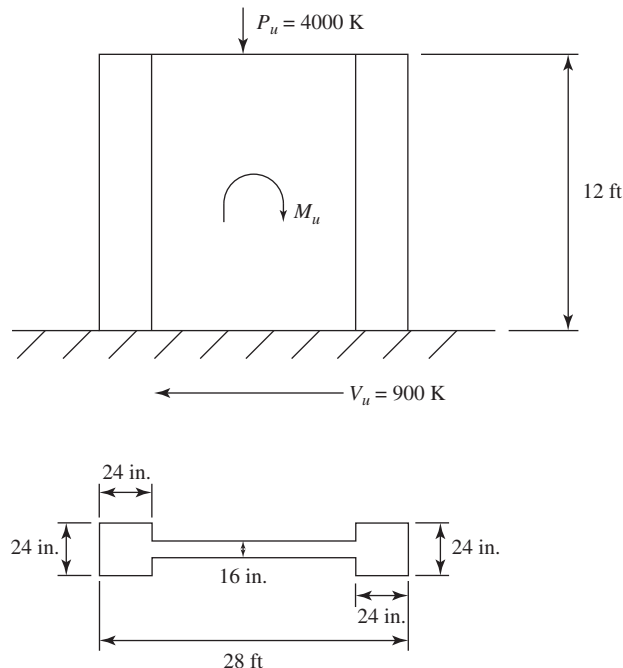
### 20.5.2.6 Summary: Design of Special Structural Wall

- Step 1.** Determine minimum reinforcement ratio according to Section 20.5.2.1 and design horizontal and vertical reinforcement for the wall web.
- Step 2.** Check the shear strength of the wall according to Section 20.5.2.2.
- Step 3.** Design the wall for flexure and axial forces, assuming that the wall behaves as a column, and include all reinforcement in the cross section of the wall and reinforcement in boundary elements and the web in calculations (Section 20.5.2.3).
- Step 4.** Check whether the boundary elements need to be specially detailed according to Section 20.5.2.4. If conditions are satisfied, design the transverse reinforcement of boundary elements by the provisions given for the special moment frame members subjected to bending and axial forces.
- Step 5.** Design the coupling beams as shown in Section 20.5.2.5.

#### Example 20.8

Design the wall section given in Fig. 20.34 as a special structural wall.

Given: Forces are  $P_u = 4000$  K,  $M_u = 45,000$  kip · ft,  $V_u = 900$  K; boundary elements are  $24 \times 24$ -in. columns; wall web thickness is 16 in.; wall length is 28 ft; wall height is 12 ft; normal-weight concrete with  $f'_c = 4000$  psi; normal-weight concrete, and  $f_y = 60,000$  psi. Boundary elements are reinforced with 16 no. 11 bars.



**Figure 20.34** Example 20.8: Structural wall.

**Solution**

1. Reinforcement requirements. To determine minimum reinforcement ratio check whether  $V_u > A_{cv}\lambda\sqrt{f'_c}$

$$A_{cv} = 16 \times (28 \times 12) = 5376 \text{ in.}^2$$

$$A_{cv}\lambda\sqrt{f'_c} = 5376 \times 1 \times \sqrt{4000}/1000 = 340 \text{ K} < V_u = 900 \text{ K}$$

$$\Rightarrow \min \rho_i = \frac{A_{sv}}{A_{cv}} = \rho_t = 0.025$$

Minimum reinforcement in both directions, longitudinal and transverse, per foot of wall can be determined as follows:

$$A_{cv} = 16 \times 12 = 192 \text{ in.}^2 \text{ per foot of wall}$$

$$A_s = 0.025 \times 192 = 0.48 \text{ in.}^2 \text{ per foot of wall}$$

Check whether two curtains of reinforcement are needed:

$$2A_{cv}\lambda\sqrt{f'_c} = \frac{(2)(5376)(1)\sqrt{4000}}{1000} = 680 \text{ K} < V_u = 900 \text{ K}$$

Two curtains of reinforcement are required.

Shear strength upper limit =  $\phi 8A_{cv}\sqrt{f'_c} = 2040 \text{ K} > 900 \text{ K}$  safe.

Choose no. 5 bars:

$$A_s = 2 \times (0.31) = 0.62 \text{ in.}^2$$

$$\text{Spacing}(s) = \frac{0.62}{0.48} \times 12 = 15.5 \text{ in.} < 18 \text{ in.}$$

Choose  $s = 15 \text{ in.}$  (See Fig. 20.35)

2. Shear strength requirements. Check whether the two curtains of no. 5 bars spaced 15 in. on center can sustain applied shear force at the base. For  $h_w/l_w = \frac{12}{18} = 0.43 < 1.5$ ,

$$\alpha_c = 3.0 \quad (\text{ACI code, Section 18.10.4.1})$$

$$\rho_t = \frac{0.62}{16 \times 12} = 0.003$$

$$\phi V_n = \phi A_{cv}(\alpha_c \sqrt{f'_c} + \rho_t f_y)$$

$$= 0.75 \times 5376(3 \times 1 \times \sqrt{4000} + 0.003 \times 60,000)/1000 = 1490 \text{ K} > 900 \text{ K}$$

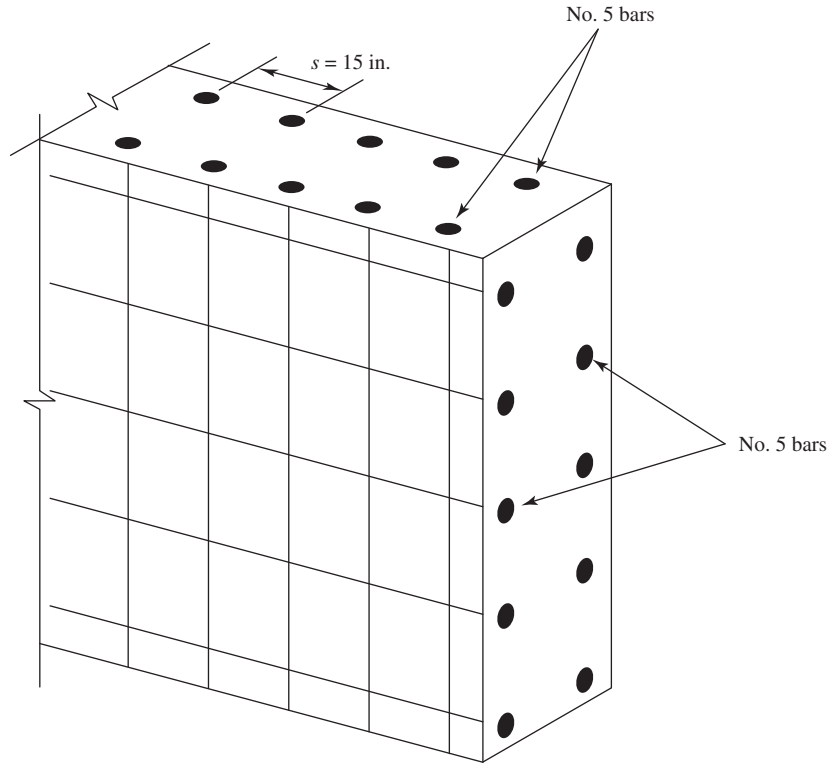
Two curtains of no. 5 bars spaced 15 in. center to center can sustain applied shear force at the base.

Check: The reinforcement ratio:

$$\rho_l > \rho_t \quad \text{if} \quad \frac{h_w}{l_w} < 2.0 \quad (\text{ACI code, Section 18.10.4.3})$$

$$\text{Since} \quad \frac{h_w}{l_w} = 0.43, \rho_l = \rho_t$$

Provide no. 5 bar spaced 15 in. in both directions (safe).



**Figure 20.35** Example 20.8: Reinforcement detailing of a wall web.

3. Design for flexure and axial forces. Wall is designed as column subjected to axial load and bending:

$$P_u = 4000 \text{ K}$$

$$M_u = 45,000 \text{ kip} \cdot \text{ft}$$

$$e = \frac{M_u}{P_u} = \frac{45,000}{4000} \times 12 = 135 \text{ in.}$$

$$M_n = \frac{M_u}{\phi} = \frac{45,000}{0.65} = 69,230 \text{ Kip} \cdot \text{ft}$$

$$P_n = \frac{P_u}{\phi} = \frac{4000}{0.65} = 6153 \text{ K}$$

Total area of reinforcement consists of 32 no. 11 bars in boundary elements and 40 no. 5 bars in the web:

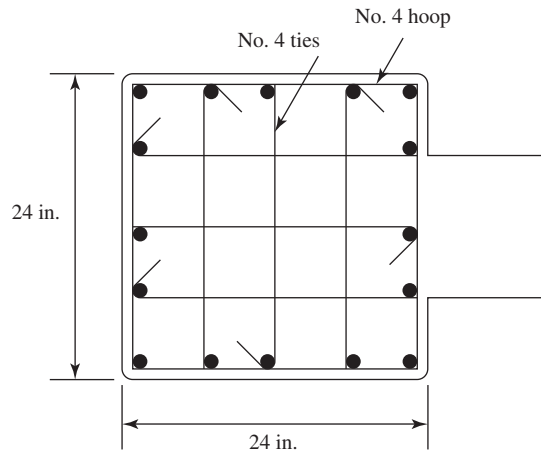
$$A_s = 32 \times 1.56 + 40 \times 0.31 = 32.3 \text{ in.}^2$$

$$A_g = 5760 \text{ in.}^2$$

$$\rho = \frac{62.3}{5760} = 0.0109 > 0.01 \quad \text{and} \quad < 0.06 \quad (\text{OK})$$

$$\frac{P_n}{f'_c A_g} = \frac{6153 \times 1000}{4000 \times 5760} = 0.267$$





**Figure 20.36** Example 20.8: Boundary element reinforcement.

From the interaction diagram,

$$\frac{M_n}{f'_c A_g h} = 0.162$$

$$M_n = 0.162 \times 4000 \times 5760 \times 28 \times 12 = 104,509 \text{ kip} \cdot \text{ft} > 69,230 \text{ kip} \cdot \text{ft} \quad (\text{OK})$$

4. Special boundary element requirements. The shear-based approach is used to determine whether the special boundary elements are required.

$$A_g = 5376 \text{ in.}^2$$

$$I_g = \frac{16 \times (28 \times 12)^3}{12} = 50,577,408 \text{ in.}^4$$

$$\frac{l_w}{2} = \frac{28 \times 12}{2} = 168 \text{ in.}$$

Maximum compressive stress in the wall is given as

$$\frac{P_u}{A_g} + \frac{M_u l_w}{I_g} = \frac{4,000,000}{5376} + \frac{45,000,000 \times 12}{50,577,408} 168 = 2538 \text{ psi}$$

$$0.2f'_c = 0.2 \times 4000 = 800 \text{ psi} < 2538 \text{ psi}$$

A special boundary element is needed. Transverse reinforcement of boundary element should be designed as for members of special moment frame subjected to axial load and bending (Fig. 20.36).

Use no. 4 hoops and crossties around longitudinal bars in both directions. Maximum spacing of transverse reinforcement should be determined as follows:

$$s_{\max} = \begin{cases} 0.25 \times (\text{smallest member dimension}) = 0.25 \times 24 = 6 \text{ in.} \\ 6 \times (\text{diameter of longitudinal bar}) = 6 \times 1.41 = 8.5 \text{ in.} \\ s_x = 4 + \left( \frac{14 - h_x}{3} \right) = 4 + \left( \frac{14 - 6}{3} \right) = 6.67 \text{ in.} \end{cases}$$

Use  $s = 6 \text{ in.}$  (governs).

Required cross-section area:

$$A_{sh} = \frac{0.09s_b f'_c}{f_y} = \frac{0.09 \times 6 \times [24 - (2 \times 1.5) - 0.5] \times 4}{60} = 0.738 \text{ in.}^2$$

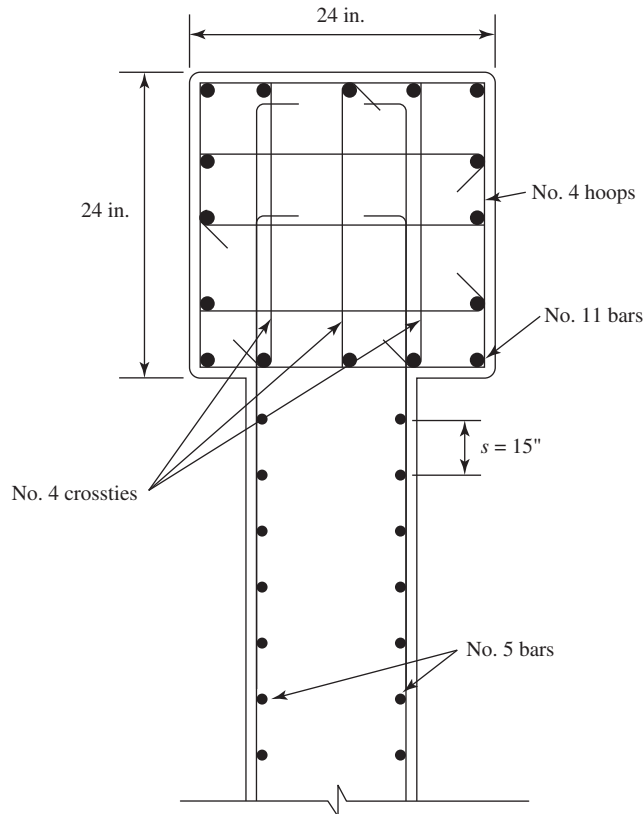
Number 4 hoops with crosssties around every longitudinal bar provide

$$A_{sh} = 5 \times 0.2 = 1.0 \text{ in.}^2 > 0.738 \text{ in.}^2 \quad (\text{OK})$$

Development length of no. 5 bars assuming that the hooks are used (ACI Code, Section 18.8.5.1) is

$$l_{dh} \geq \begin{cases} \frac{f_y d_b}{65 \sqrt{f'_c}} = \frac{60,000 \times 0.625}{65 \sqrt{4000}} = 9.1 \text{ in.} \\ 8d_b = 8 \times 0.625 = 5 \text{ in.} \\ 6 \text{ in.} \end{cases}$$

Therefore,  $l_{dh} = 9.1 \text{ in.}$  Also  $l_d = 3.5l_{dh} = 3.5 \times 9 = 31.5 \text{ in.}$  the dimension of the boundary element = 24 in. Use the hooks to anchor reinforcement (Fig. 20.37).



**Figure 20.37** Example 20.8: Reinforcement detailing.

### 20.5.3 Structures in the Areas of Moderate Seismic Risk: Intermediate Moment Frames (ACI Code, Section 18.4)

In regions of moderate seismic risk (SDC of C), the moment frames should be designed as intermediate moment frames. The ACI Code, Section 18.4, gives provisions for the design and detailing of intermediate moment frames as follows:

**20.5.3.1 Longitudinal Reinforcement Requirements.** If the compressive axial load for the  $< A_g f'_c / 10$ , the member is considered to be subjected only to bending and the following is applicable (ACI Code, Section 18.4.2.6):

Positive moment strength at joint  $\geq \frac{1}{3}$  negative moment strength at that face of the joint:

$$M_{nl}^+ \geq \frac{1}{3} M_{nl}^- \quad (\text{left joint}) \quad (20.57a)$$

$$M_{nr}^+ \geq \frac{1}{3} M_{nr}^- \quad (\text{right joint}) \quad (20.57b)$$

Neither the positive nor the negative moment strength at any section along the length of the member should be less than  $\frac{1}{5}$  the maximum moment strength provided at the face of either joint:

$$\phi M_n^+ \quad \text{or} \quad \phi M_n^- \geq \frac{1}{5} \max (\phi M_n \text{ at either joint}) \quad (20.58)$$

### 20.5.3.2 Transverse Reinforcement Requirements

**Beams.** It is assumed that the plastic hinges will form at the end of the beams. According to this, the beam ends should be specially detailed to provide the beam with necessary ductility.

Hoops should also be provided over a length equal to  $2d$  ( $d$  is the effective depth of the beam) measured from the face of support toward midspan. The first hoop should be located at a distance  $\leq 2$  in. from the face of support.

Maximum spacing of transverse reinforcement should not exceed the smallest of

$$S_{\max} \leq \begin{cases} \frac{d}{4} \\ 8 \times (\text{diameters of smallest longitudinal bar enclosed}) \\ 24 \times (\text{diameters of hoop bar}) \\ 12 \text{ in.} \end{cases} \quad (20.59)$$

When hoops are not required, stirrups should be used. Spacing of stirrups should be  $\leq d/2$  through the length of the member (ACI Code, Section 18.4.2.5).

**Columns.** Transverse reinforcement of columns of intermediate moment frame should be designed with spiral reinforcement or with hoops and stirrups as follows: Spiral reinforcement should satisfy the requirements for ordinary compression member (ACI Code, Section 25.7.3): Hoops should be provided at both ends of the member over a length  $l_0$  measured from the face of the joint, spaced a distance  $s_0$ . (ACI Code, Section 18.4.3.3). Spacing  $S_0$  shall not exceed the smallest of the four items listed below or

$$S_{\max} \leq \begin{cases} 8 \times (\text{diameters of smallest longitudinal bar}) \\ 24 \times (\text{diameters of hoop bar}) \\ \frac{1}{2} \text{ of smallest cross-section dimension of column} \\ 12 \text{ inch} \end{cases} \quad (20.60)$$

Length  $l_0$  shall not be less than the largest of the three items listed below or

$$l_0 \geq \begin{cases} \frac{1}{6} \text{ of clear length of member} \\ \text{Maximum cross-section dimension of member} \\ 18 \text{ in} \end{cases} \quad (20.61)$$

The first hoop should be located a distance  $\leq s_0/2$  from the joint face. Outside the length  $l_0$ , spacing  $s_0$  should conform to ACI Code, Section 10.7.6 and Section 9.7.6.2.2 or

$$s_0 \leq \begin{cases} \frac{d}{2} \\ 24 \text{ in.} \end{cases} \quad (20.62)$$

## REFERENCES

1. American Concrete Institute (ACI). *Building Code Requirements for Structural Concrete*. ACI Code 318-14. ACI, Detroit, MI, 2014.
2. International Code Council (ICC). *International Building Code 2012*. ICC, Country Club Hills, IL, 2012.
3. S. K. Ghosh and A. D. Fanella. *Seismic and Wind Design of Concrete Buildings*. 2000 IBC, ASCE 7-98, ACI 318-99. International Code Council, Country Club Hills, IL, 2003.
4. S. K. Ghosh, A. W. Domel, Jr., and A. D. Fanella. *Design of Concrete Buildings for Earthquake and Wind Forces*, 2nd ed. Portland Cement Association, Skokie, IL, 1995.
5. Portland Cement Association (PCA). *Notes on ACI 318-02 Building Code Requirements for Structural Concrete with Design Applications*. PCA, Skokie, IL, 2002.
6. *Minimum Design Loads for Buildings and other Structures*. ASCE 7-10. ASCE, Reston, VA, American Society of Civil Engineering (ASCE). 2010.

## PROBLEMS

- 20.1 Determine seismic design category for a five-story building in the area of northern California if the soil is hard rock.
- 20.2 Determine base shear for a two-story building located in the area of high seismic risk where  $S_S = 1.3 g$  and  $S_1 = 0.6 g$ , on soil class B. Assume that the idealized weight of the first floor is 50 Kip and of the second floor is 60 Kip.
- 20.3 Determine lateral seismic forces for the five-story building assuming that the idealized mass of each floor is 1000 Kip. Consider the structure a building risk category III, site class C.
- 20.4 Design the longitudinal reinforcement for the beam on the second floor of a special moment-frame four-story building assuming the clear span of a beam is 24 ft. Each story height is 12 ft. Beam dimensions are  $20 \times 24$  in., and the column is  $24 \times 24$  in. Bending moments acting on the beam are given in the following table.

Load	Location	Bending Moment (kip · ft)
Dead	Support	-70
	Midspan	45
Live	Support	25
	Midspan	18
Earthquake	Support	$\pm 180$
	Midspan	0

- 20.5** Design the transverse reinforcement for the beam of a special moment-resisting frame. The beam is reinforced with five no. 8 bars and is  $24 \times 30$  in. The load acting on the beam is  $W_D = 3.0$  kip/ft,  $W_L = 1.5$  kip/ft, and clear span is 24 ft.
- 20.6** Design the reinforcement for a column on the first floor of a four-story building following the provisions for special moment-resisting frame reinforcement. The column is  $30 \times 30$  in. and 12 ft high. Nominal flexural strength of the beam framing into the column  $M_n = 650$  Kip  $\cdot$  ft. The axial load acting on the second-floor column is  $P_u = 1,920$  Kip, axial load acting on the first floor is  $P_u = 2000$  Kip, and minimum axial load in load combination is 1010 K. The shear force is  $V_u = 120$  Kip. Draw the detail of reinforcement.
- 20.7** Design the reinforcement for a wall having a total height of 28 ft and span of 35 ft. The total gravity load acting on the wall is 5,200 Kip, factored moment  $M_u$  is 50,000 kip  $\cdot$  ft, and base shear is  $V$  is 1,000 Kip. Wall thickness is 20 in. and boundary elements are  $25 \times 25$  in.

# CHAPTER 21

## BEAMS CURVED IN PLAN



Curved beams in an office building.

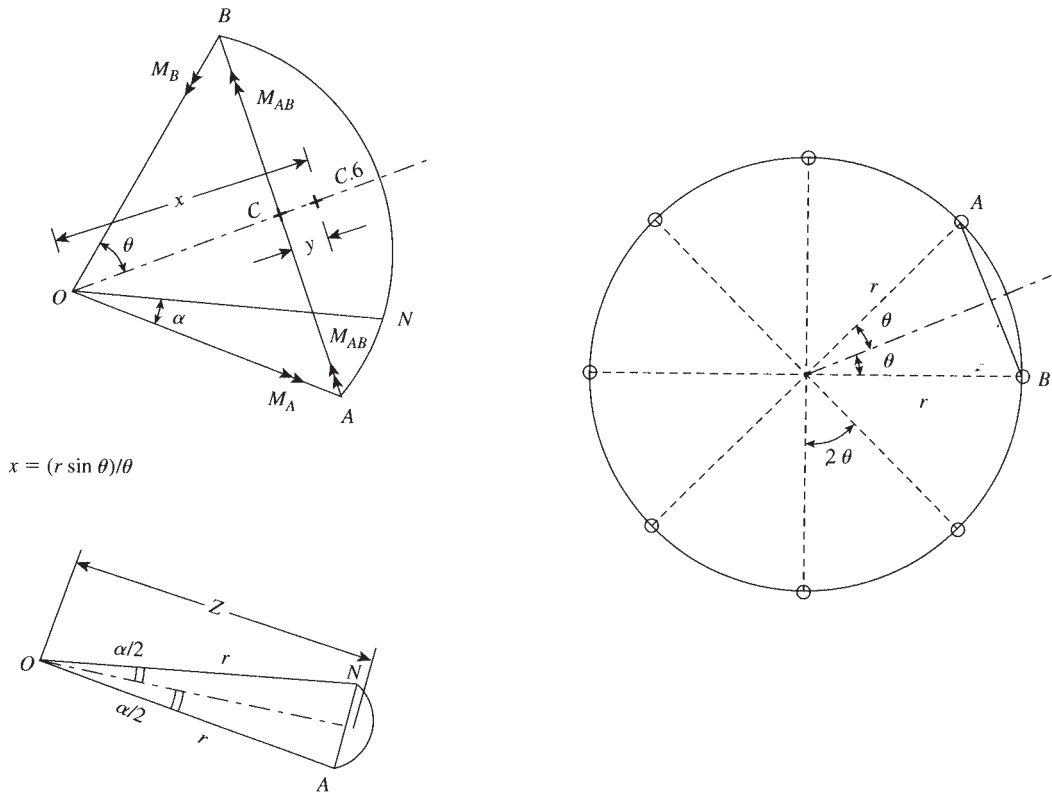
### 21.1 INTRODUCTION

Beams curved in plan are used to support curved floors in buildings, balconies, curved ramps and halls, circular reservoirs, and similar structures. In a curved beam, the center of gravity of the loads acting normal to the plane of curvature lies outside the line joining its supports. This situation develops torsional moments in the beam, in addition to bending moments and shearing forces. To maintain the stability of the beam against overturning, the supports must be fixed or continuous. In this chapter, the design of curved beams subjected to loads normal to the plane of curvature is presented. Analysis of curved beams subjected to loads in the plane of curvature is usually discussed in books dealing with mechanics of solids.

Analysis of beams curved in plan was discussed by Wilson and Quereau [1]. They introduced formulas and coefficients to compute stresses in curved flexural members. Timoshenko [2, 3] also introduced several expressions for calculating bending stresses in square and rectangular sections. Tables and formulas for the calculation of bending and torsional moments, shear, and deflections for different cases of loadings on curved beams and rings are presented by Roark and Young [4].

### 21.2 UNIFORMLY LOADED CIRCULAR BEAMS

The first case to be considered here is that of a circular beam supported on columns placed at equal distances along the circumference of the beam and subjected to normal loads. Due to symmetry, the



$$x = (r \sin \theta) / \theta$$

Figure 21.1 Circular beam.

column reactions will be equal, and each reaction will be equal to the total load on the beam divided by the number of columns. Referring to Fig. 21.1, consider the part  $AB$  between two consecutive columns of the ring beam. The length of the curve  $AB$  is  $r(2\theta)$ , and the total load on each column is  $P_u = w_u r(2\theta)$ , where  $r$  is the radius of the ring beam and  $w_u$  is the factored load on the beam per unit length. The center of gravity of the load on  $AB$  lies at a distance

$$x = \left( \frac{r \sin \theta}{\theta} \right)$$

from the center  $O$ . The moment of the load  $P_u$  about  $AB$  is

$$M_{AB} = P_u \times y = P_u(x - r \cos \theta) = w_u r(2\theta) \left( \frac{r \sin \theta}{\theta} - r \cos \theta \right)$$

Consequently, the two reaction moments,  $M_A$  and  $M_B$ , are developed at supports  $A$  and  $B$ , respectively. The component of the moment at support  $A$  about  $AB$  is  $M_A \sin \theta = M_B \sin \theta$ . Equating the applied moment,  $M_{AB}$ , to the reaction moments components at  $A$  and  $B$ ,

$$2M_A \sin \theta = M_{AB} = w_u r(2\theta) \left( \frac{r \sin \theta}{\theta} - r \cos \theta \right)$$

$$M_A = M_B = w_u r^2 (1 - \theta \cot \theta) \quad (21.1)$$

The shearing force at support  $A$  is

$$V_A = \frac{P_u}{2} = w_u r \theta \quad (21.2)$$

The shearing force at any point  $N$ ,  $V_N$ , is  $V_A - w_u (r\alpha)$ , or

$$V_N = w_u r(\theta - \alpha) \quad (21.3)$$

The load on  $AN$  is  $w_u(r\alpha)$  and acts at a distance equal to

$$Z = \frac{r \sin \alpha/2}{\alpha/2}$$

from the center  $O$ . The bending moment at point  $N$  on curve  $AB$  is equal to the moment of all forces on one side of  $O$  about the radial axis  $ON$ .

$$\begin{aligned} M_N &= V_A(r \sin \alpha) - M_A \cos \alpha - (\text{load on the curve } AN) \left( Z \sin \frac{\alpha}{2} \right) \\ M_N &= w_u r \theta (r \sin \alpha) - w_u r^2 (1 - \theta \cot \theta) \cos \alpha \\ &\quad - (w_u r \alpha) \left( \frac{r \sin \alpha/2}{\alpha/2} \times \sin \frac{\alpha}{2} \right) \\ &= w_u r^2 \left[ \theta \sin \alpha - \cos \alpha + (\theta \cot \theta \cos \alpha) - 2 \sin^2 \frac{\alpha}{2} \right] \\ M_N &= w_u r^2 [\theta \sin \alpha + (\theta \cot \theta \sin \alpha) - 1] \end{aligned} \quad (21.4)$$

(Note that  $\cos \alpha = 1 - 2 \sin^2 \alpha/2$ .) The torsional moment at any point  $N$  on curve  $AB$  is equal to the moment of all forces on one side of  $N$  about the tangential axis at  $N$ .

$$\begin{aligned} T_N &= M_A \sin \alpha - V_A \times r(1 - \cos \alpha) + w_u r \alpha \left( r - \frac{r \sin \alpha/2}{\alpha/2} \times \frac{\cos \alpha}{2} \right) \\ &= w_u r^2 (1 - \theta \cot \theta) \sin \alpha - w_u r^2 \theta (1 - \cos \alpha) + w_u r^2 (\alpha - \sin \alpha) \\ T_n &= w_u r^2 (\alpha - \theta + \theta \cos \alpha - \theta \cot \theta \sin \alpha) \end{aligned} \quad (21.5)$$

To obtain the maximum value of the torsional moment  $T_N$ , differentiate Eq. 21.5 with respect to  $\alpha$  and equate it to 0. This step will give the value of  $\alpha$  for maximum  $T_N$ :

$$\sin \alpha = \frac{1}{\theta} [\sin^2 \theta \pm \cos \theta \sqrt{\theta^2 - \sin^2 \theta}] \quad (21.6)$$

The values of the support moment, midspan moment, the torsional moment, and its angle  $\alpha$  from the support can be calculated from Eqs. 21.1 through 21.6. Once the number of supports  $n$  is chosen, the angle  $\theta$  is known:

$$2\theta = \frac{2\pi}{n} \quad \text{and} \quad \theta = \frac{\pi}{n}$$

and the moment coefficients can be calculated as shown in Table 21.1. Note that the angle  $\alpha$  is half the central angle between two consecutive columns.

$$\begin{aligned} P_u(\text{load on each column}) &= w_u r(2\theta) = w_u r \left( \frac{2\pi}{n} \right) \\ V_u(\text{maximum shearing force}) &= \frac{P_u}{2} \end{aligned}$$



**Table 21.1** Force Coefficients of Circular Beams

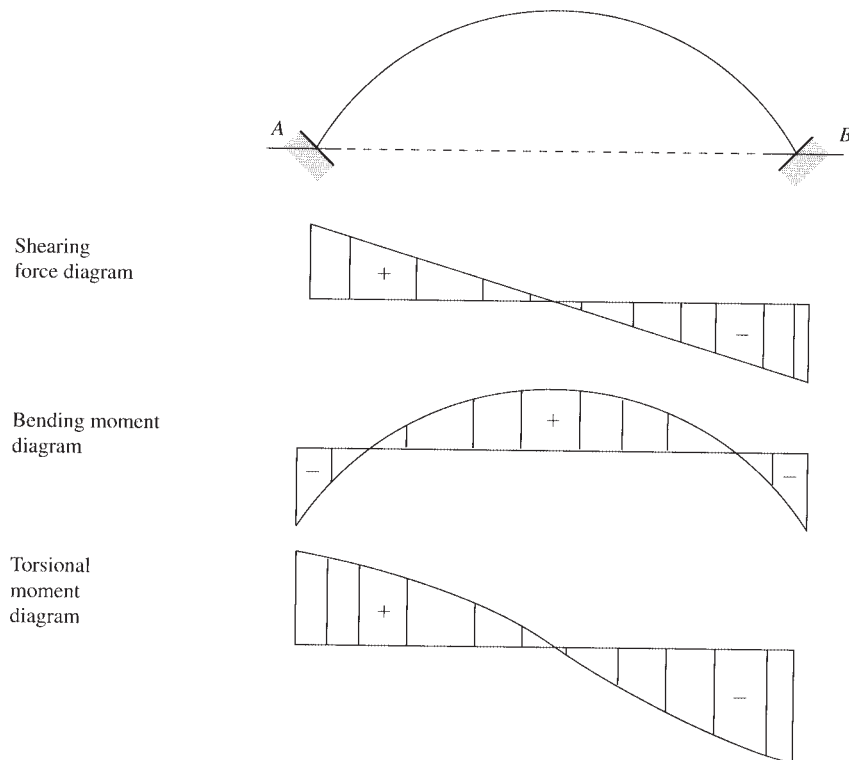
Number of Supports, $n$	$\theta = \frac{\pi}{n}$	$K_1$	$K_2$	$K_3$	$\alpha^\circ$ for $T_u$ (max)
4	90	0.215	0.110	0.0330	19.25
5	72	0.136	0.068	0.0176	15.25
6	60	0.093	0.047	0.0094	12.75
8	45	0.052	0.026	0.0040	9.50
9	40	0.042	0.021	0.0029	8.50
10	36	0.034	0.017	0.0019	7.50
12	30	0.024	0.012	0.0012	6.25

$$\text{Negative moment at any support} = K_1 w_u r^2 \tag{21.7}$$

$$\text{Positive moment at midspan} = K_2 w_u r^2 \tag{21.8}$$

$$\text{Maximum torsional moment} = K_3 w_u r^2 \tag{21.9}$$

The variation of the shearing force and bending and torsional moments along a typical curved beam  $AB$  are shown in Fig. 21.2.



**Figure 21.2** Forces in a circular beam.

**Example 21.1**

Design a circular beam supported on eight equally spaced columns. The centerline of the columns lies on a 40-ft-diameter circle. The beam carries a uniform dead load of 6 k/ft and a live load of 4 k/ft. Use normal-weight concrete with  $f'_c = 5$  ksi,  $f_y = 60$  ksi, and  $b = 14$  in.

**Solution**

1. Assume a beam size of 14 × 24 in. The weight of the beam is

$$\frac{14 \times 24}{12 \times 12}(0.150) = 0.35 \text{ K/ft}$$

The factored uniform load is  $w_u = 1.2(6 + 0.35) + 1.6(5) = 15.7 \text{ K/ft}$

2. Because the beam is symmetrically supported on eight columns, the moments can be calculated by using Eqs. 21.7 through 21.9 and Table 21.1. Negative moment at any support is  $K_1 w_u r^2 = 0.052(15.7)(20)^2 = 326.6 \text{ K}\cdot\text{ft}$ . The positive moment at midspan is  $K_2 w_u r^2 = 0.216(15.7)(20)^2 = 163.3 \text{ K}\cdot\text{ft}$ . The maximum torsional moment is  $K_3 w_u r^2 = 0.004(15.7)(20)^2 = 25.12 \text{ K}\cdot\text{ft}$ . Maximum shear is

$$V_u = \frac{P_u}{2} = \frac{w_u r}{2} \left( \frac{2\pi}{n} \right) = (15.7)(20) \left( \frac{\pi}{8} \right) = 123.3 \text{ K}$$

3. For the section at support,  $M_u = 326.6 \text{ K}\cdot\text{ft}$ . Let  $d = 21.5$  in.; then

$$R_u = \frac{M_u}{bd^2} = \frac{326.6 \times 12,000}{14(21.5)^2} = 605 \text{ psi}$$

For  $f'_c = 4$  ksi and  $f_y = 60$  ksi,  $\rho = 0.0126 < \rho_{\max} = 0.018$ ,  $\phi = 0.9$ :

$$A_s = 0.0126 \times 14 \times 21.5 = 3.8 \text{ in.}^2$$

4. For the section at midspan,  $M_u = 163.3 \text{ K}\cdot\text{ft}$

$$R_u = \frac{163.3 \times 12,000}{14(21.5)^2} = 303 \text{ psi}$$

$$\rho = 0.006 \quad \text{and} \quad A_s = 0.006 \times 14 \times 21.5 = 1.81 \text{ in.}^2$$

Use two no. 9 bars.

5. Maximum torsional moment is  $T_u = 25.12 \text{ K}\cdot\text{ft}$ , and it occurs at an angle  $\alpha = 9.5^\circ$  from the support (Table 21.1). Shear at the point of maximum torsional moment is equal to the shear at the support minus  $w_u r \alpha$ .

$$V_u = 123.3 - 15.7(20) \left( \frac{9.5}{180} \times \pi \right) = 71.24 \text{ K}$$

The procedure for calculation of the shear and torsional reinforcement for  $T_u = 25.12 \text{ K}\cdot\text{ft}$  and  $V_u = 71.24 \text{ K}$  is similar to Example 15.2

- a. Shear reinforcement is required when  $V_u > \phi V_c/2$ :

$$\phi V_c = 2\phi\lambda\sqrt{f'_c}bd = 2(0.75)(1.0)\sqrt{4000}(14 \times 21.5) = 28.6 \text{ K}$$

since  $\phi V_c/2 = 14.3 \text{ K} < V_u = 71.24 \text{ K}$ .

Shear reinforcement is required.

b. Torsional reinforcement is required when

$$T_u > T_a = \phi \lambda \sqrt{f'_c} \left( \frac{A_{cp}^2}{P_{cp}} \right)$$

$$A_{cp} = x_0 y_0 = 14 \times 24 = 336 \text{ in.}^2$$

$$P_{cp} = 2(x_0 + y_0) = 2(14 + 24) = 76 \text{ in.}$$

$$T_a = 0.75 \times 1 \times \sqrt{4000} \left( \frac{336^2}{76} \right) = 70.5 \text{ K} \cdot \text{in.}$$

$$\text{since } T_u = 25.12 \text{ K} \cdot \text{ft} = 301.4 \text{ K} \cdot \text{in.} > T_a$$

Therefore, torsional reinforcement is required.

c. Design for shear:

i.  $V_u = \phi V_c + \phi V_s$  and  $\phi V_c = 28.6 \text{ K}$ . Then  $71.24 = 28.6 + 0.75 V_s$ , so  $V_s = 56.8 \text{ K}$ .

ii. Maximum  $V_s = 8\sqrt{f'_c}bd = 8\sqrt{4000}(14 \times 21.5) = 152.3 \text{ K} > V_u$ .

iii.  $\frac{A_v}{S} = \frac{V_s}{f_y d} = \frac{56.8}{60 \times 21.5} = 0.044 \text{ in.}^2/\text{in.}$  (2legs)

$$\frac{A_v}{2S} = 0.022 \text{ in.}^2/\text{in.} \quad (\text{one leg})$$

d. Design for torsion:

i. Choose no. 4 stirrups and a 1.5-in. concrete cover:

$$x_1 = 14 - 3.5 = 10.5 \text{ in.} \quad y_1 = 24 - 3.5 = 20.5 \text{ in.}$$

$$A_{0h} = x_1 y_1 = 10.5(20.5) = 215.25 \text{ in.}^2$$

$$A_0 = 0.85A_{0h} = 183 \text{ in.}^2$$

$$p_h = 2(x_1 + y_1) = 2(10.5 + 20.5) = 62 \text{ in.}$$

For  $\theta = 45^\circ$ ,  $\cot \theta = 1.0$ .

ii. Check the adequacy of the size of the section using Eq. 15.21:

$$\sqrt{\left( \frac{V_u}{b_w d} \right)^2 + \left( \frac{T_u p_h}{1.7 A_0^2} \right)^2} \leq \phi \left( \frac{V_c}{b_w d} + 8\sqrt{f'_c} \right)$$

$$\phi V_c = 28.6 \text{ K} \quad V_c = 38.12 \text{ K}$$

$$\text{Left - handside} = \sqrt{\left( \frac{71,240}{14 \times 21.5} \right)^2 + \left[ \frac{301,400 \times 62}{1.7(215.25)^2} \right]^2} = 335 \text{ psi}$$

$$\text{Right - handside} = 0.75 \left( \frac{38,120}{14 \times 21.5} + 8\sqrt{4000} \right) = 558 \text{ psi} > 335 \text{ psi}$$

The section is adequate.

iii. Determine the required closed stirrups due to  $T_u$  from:

$$\frac{A_t}{S} = \frac{T_n}{2A_0 f_y \cot \theta}, \quad T_n = \frac{T_u}{\phi}, \quad \phi = 0.75, \quad \cot \theta = 1.0$$

$$= \frac{301.4}{0.75 \times 2 \times 183 \times 60} = 0.0183 \text{ in.}^2/\text{in.} \quad (\text{one leg})$$

- iv. The total area of one leg stirrup is  $0.022 + 0.0183 = 0.04 \text{ in.}^2/\text{in.}$  For no. 4 stirrups, area of one leg =  $0.2 \text{ in.}^2$ . Spacing of closed stirrups is  $0.2/0.04 = 5.0 \text{ in.}$ , say, 5.5 in.

$$\text{Minimum } S = \frac{p_h}{8} = \frac{62}{8} = 7.75 \text{ in.} > 5.0 \text{ in.}$$

$$\text{Minimum } \frac{A_{vt}}{S} = \frac{50b_w}{f_y} = \frac{50(14)}{60,000} = 0.0117 \text{ in.}^2/\text{in.}$$

This is less than the  $A_t/s$  provided. Use no. 4 closed stirrups spaced at 5.5 in.

- e. Longitudinal bars  $A_l$  equal  $(A_t/s) p_h (f_{yv}/f_{yl}) \cot^2 \theta$  (Eq. 15.27).

$$A_l = 0.018(62) \left( \frac{60}{60} \right) = 1.13 \text{ in.}^2$$

$$\begin{aligned} \text{Min. } A_l &= \frac{5\sqrt{f'_c}A_{cp}}{f_{yl}} - \left( \frac{A_t}{S} \right) p_h \left( \frac{f_{yv}}{f_{yl}} \right) \\ &= \frac{(5\sqrt{4000})(336)}{60,000} - 0.018(62) \left( \frac{60}{60} \right) = 0.64 \text{ in.}^2 < 1.0 \end{aligned}$$

Use  $A_l = 1.13 \text{ in.}^2$ , with one-third at the top, one-third at middepth, and one-third at the bottom, or  $0.33 \text{ in.}^2$  in each location. For the section at the support,  $A_s = 3.8 \text{ in.}^2 + 0.38 = 4.18 \text{ in.}^2$ . Choose two no. 10 and two no. 9 bars ( $A_s = 4.53 \text{ in.}^2$ ) as top bars. At middepth, use two no. 4 bars ( $A_s = 0.4 \text{ in.}^2$ ). Extend two no. 9 bars of the midspan section to the support. At middepth use two no. 4 bars ( $A = 0.4 \text{ in.}^2$ ). Details of the section are shown in Fig. 21.3.



Circular beams in an office building.

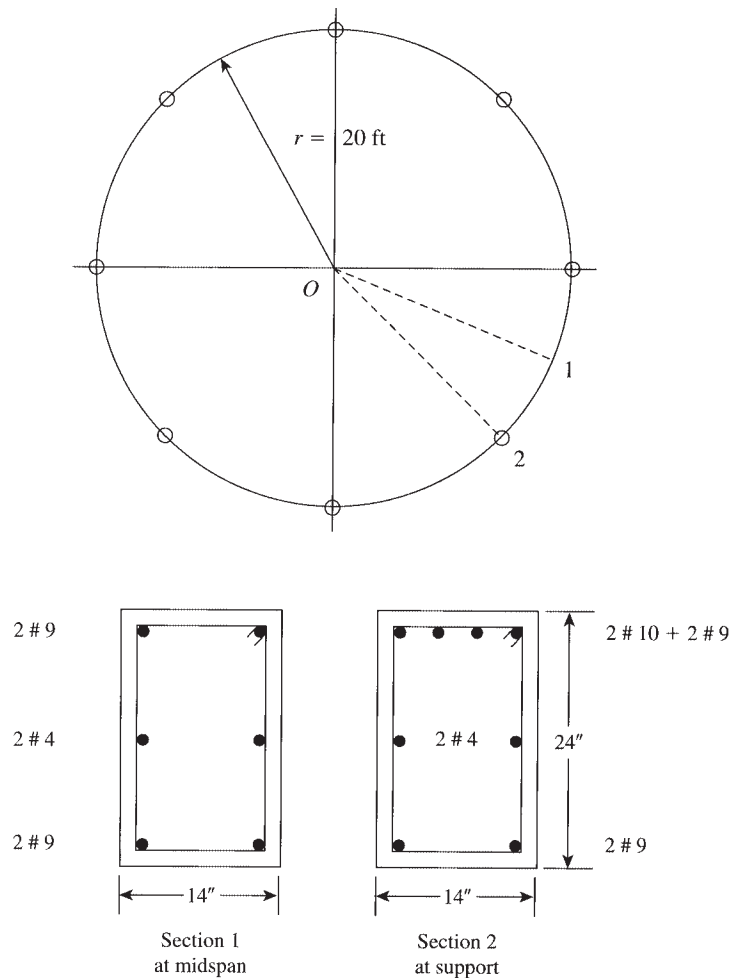
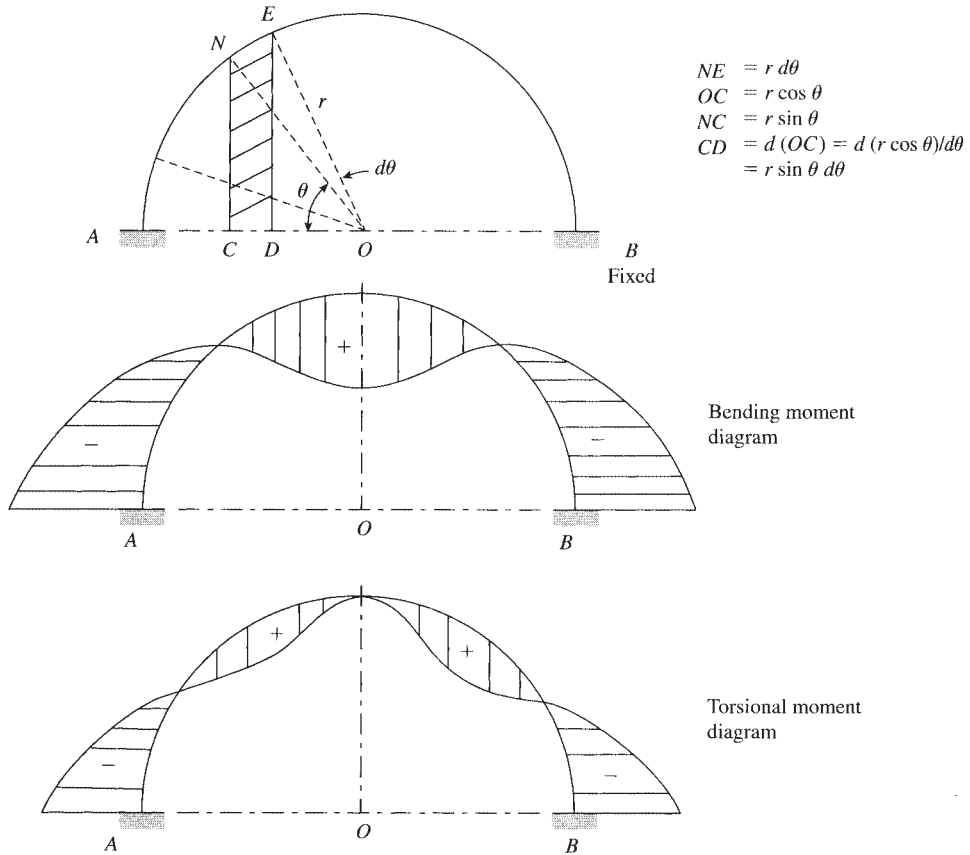


Figure 21.3 Example 21.1.

### 21.3 SEMICIRCULAR BEAM FIXED AT END SUPPORTS

If a semicircular beam supports a concrete slab, as shown in Fig. 21.4, the ratio of the length to the width of the slab is  $2r/r = 2$ , and the slab is considered a one-way slab. The beam will be subjected to a distributed load, which causes torsional moments in addition to the bending moments and shearing forces. The structural analysis of the curved beam can be performed in steps as follows.

1. *Load on beam:* The load on the curved beam will be proportional to its distance from the support  $AB$ . If the uniform load on the slab equals  $w$  psf, the load on the curved beam at any section  $N$  is equal to half the load on the area  $NCDE$  (Fig. 21.4). The lengths are  $CN = r \sin \theta$ ,  $OC = r \cos \theta$ , and  $CD = (d/d\theta)(r \cos \theta) = (r \sin \theta d\theta)$ , and the arc  $NE$  is  $r d\theta$ .



**Figure 21.4** Semicircular beam fixed at the supports.

The load on the curved beam per unit length is equal to

$$w' = \frac{w(r \sin \theta)r \sin \theta d\theta}{2(r d\theta)} = \frac{wr \sin^2 \theta}{2} \quad (21.10)$$

2. *Shearing force at A:* For a uniform symmetrical load on the slab, the shearing force at A is equal to

$$\begin{aligned} V_A = V_B &= \int_0^{\pi/2} \left( \frac{wr}{2} \sin^2 \theta \right) (r d\theta) = \frac{wr^2}{2} \left[ \frac{\theta}{2} - \frac{1}{4} \sin 2\theta \right] \\ &= \left( \frac{\pi}{8} \right) wr^2 = 0.39 wr^2 \end{aligned} \quad (21.11)$$

3. *Bending moment at A:* Taking moments about the line AB, the bending moment at A is equal to

$$\begin{aligned} M_A = M_B &= \int_0^{\pi/2} w'(r d\theta) \times (r \sin \theta) \\ &= \int_0^{\pi/2} \left( \frac{wr}{2} \sin^2 \theta \right) (r \sin \theta)(r d\theta) = -\frac{wr^3}{3} \end{aligned} \quad (21.12)$$

4. *Torsional moment at support A.*  $T_A$  can be obtained by differentiating the strain energy of the beam with respect to  $T_A$  and equating it to 0. Considering that  $T_A$  is acting clockwise at A, then the bending moment at any section  $N$  is calculated as follows:

$$M_N = V_A(r \sin \theta) - M_A \cos \theta + T_A \sin \theta - \int_0^\theta \left( \frac{wr}{2} \sin^2 \alpha \right) (r d\alpha) \times r \sin (\theta - \alpha)$$

$$M_N = wr^3 \left[ \frac{\pi}{8} \sin \theta - \left( \frac{1}{6} \right) (1 + \cos^2 \theta) \right] + T_A \sin \theta \quad (21.13)$$

The torsional moment at any station  $N$  on the curved beam is equal to

$$T_n = -V_A r (1 - \cos \theta) + M_A \sin \theta + T_A \cos \theta + \int_0^{\pi/2} \left( \frac{wr}{2} \sin^2 \alpha \right) (r d\alpha) \times r [1 - \cos(\theta - \alpha)]$$

$$T_N = wr^3 \left[ \frac{\pi}{8} (\cos \theta - 1) + \frac{\theta}{4} + \frac{1}{24} \sin 2\theta \right] + T_A \cos \theta \quad (21.14)$$

The strain energy is

$$U = \int \frac{M_N^2 ds}{2EI} + \int \frac{T_N^2 ds}{2GJ} \quad (21.15)$$

where

- $ds = r d\theta$
- $G =$  modulus of rigidity
- $E =$  modulus of elasticity
- $I =$  moment of inertia of section
- $J =$  rotational constant of section
- $=$  polar moment of inertia

To obtain  $T_A$ , differentiate  $U$  with respect to  $T_A$ :

$$\frac{\delta U}{\delta T_A} = \int \frac{M_N}{EI} \times \frac{dM_N}{dT_A} (r d\theta) + \int \frac{T_N}{GJ} \times \frac{dT_N}{dT_A} \times (r d\theta) = 0$$

$$\frac{dM_N}{dT_A} = \sin \theta \quad \text{and} \quad \frac{dT_N}{dT_A} = \cos \theta$$

Therefore,

$$\frac{\delta U}{\delta T_A} = \frac{r}{EI} \int_0^{\pi/2} \sin \theta \left\{ wr^2 \left[ \frac{\pi}{8} \sin \theta - \frac{1}{6} (1 + \cos^2 \theta) \right] + T_A \sin \theta \right\} d\theta$$

$$+ \frac{r}{GJ} \int_0^{\pi/2} \left\{ wr^3 \left[ \frac{\pi}{8} (\cos \theta - 1) + \frac{\theta}{4} + \frac{1}{24} \sin 2\theta \right] + T_A \cos \theta \right\} \cos \theta \times d\theta = 0$$

and

$$\frac{r}{EI} \left[ wr^3 \left( \frac{\pi^2}{32} - \frac{2}{9} \right) + T_A \left( \frac{\pi}{4} \right) \right] + \frac{r}{GJ} \left[ wr^3 \left( \frac{\pi^2}{32} - \frac{2}{9} \right) + T_A \text{left} \left( \frac{\pi}{4} \right) \right] = 0$$

**Table 21.2** Values of  $K'$  and  $\lambda$  for Different Values of  $y/x$ 

$y/x$	0.5	1.0	1.1	1.2	1.25	1.3	1.4	1.5	1.6
$K'$	0.473	0.141	0.154	0.166	0.172	0.177	0.187	0.196	0.204
$\lambda$	0.102	1.37	1.52	1.68	1.76	1.85	2.03	2.22	2.43
$y/x$	1.7	1.75	2.0	2.5	3.0	4.0	5.0	6.0	10
$K'$	0.211	0.214	0.229	0.249	0.263	0.281	0.291	0.300	0.312
$\lambda$	2.65	2.77	3.39	4.86	6.63	11.03	16.5	23.3	62.1

Let  $EI/GJ = \lambda$ ; then

$$\begin{aligned} T_A \left( \frac{\pi}{4} \right) (1 + \lambda) &= wr^3 \left[ \left( \frac{2}{9} - \frac{\pi^2}{32} \right) + \lambda \left( \frac{2}{9} - \frac{\pi^2}{32} \right) \right] \\ &= wr^3 \left( \frac{2}{9} - \frac{\pi^2}{32} \right) (1 + \lambda) = -0.0862 wr^3 (1 + \lambda) \end{aligned}$$

Therefore,

$$T_A = -0.11 wr^3 \quad (21.16)$$

Substituting the value of  $T_A$  in Eq. 21.13, the bending moment at any point  $N$  is equal to

$$M_N = wr^3 \left[ \frac{\pi}{8} \sin \theta - \frac{1}{6} (1 + \cos^2 \theta) - 0.11 \sin \theta \right] \quad (21.17)$$

Substituting the value of  $T_A$  in Eq. 21.14,

$$T_N = wr^3 \left[ \frac{\pi}{8} (\cos \theta - 1) + \frac{\theta}{4} + \frac{1}{24} \sin 2\theta - 0.11 \cos \theta \right] \quad (21.18)$$

5. The value of  $G/E$  for concrete may be assumed to be equal to 0.43. The value of  $J$  for a circular section is  $(\pi/2)r^4$ , whereas  $J$  for a square section of side  $x$  is equal to  $0.141x^4$ . For a rectangular section with short and long sides  $x$  and  $y$ , respectively,  $J$  can be calculated as follows:

$$J = K' \times y^3 \quad (21.19)$$

The values of  $K'$  are calculated as follows:

$$K' = \frac{1}{16} \left[ \frac{16}{3} - 3.36 \frac{x}{y} \left( 1 - \frac{x^4}{12y^4} \right) \right] \quad (21.20)$$

whereas

$$\lambda = \frac{EI}{GJ} = \left( \frac{1}{0.43} \right) \left( \frac{xy^3}{12} \right) \left( \frac{1}{K'yx^3} \right) = \frac{1}{5.16 K'} \left( \frac{y}{x} \right)^2$$

Values of  $K'$  and  $\lambda$  are both shown in Table 21.2.

### Example 21.2

Determine the factored bending and torsional moments in sections  $C$  and  $D$  of the 10-ft-radius semicircular beam  $ADCB$  shown in Fig. 21.5. The beam is part of a floor slab that carries a uniform factored load of 304 psf (including self-weight).



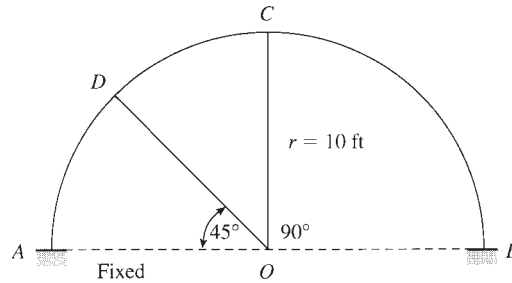


Figure 21.5 Example 21.2.

**Solution**

1. Factored load  $w_u = 304$  psf.
2. For the section at  $C$ ,  $\theta = \pi/2$  and  $w_u r^3 = 0.304(10)^3 = 304$ . From Eq. 21.17,

$$M_c = 304 \left[ \frac{\pi}{8} \sin \frac{\pi}{2} - \frac{1}{6} \left( 1 + \cos^2 \frac{\pi}{2} \right) - 0.11 \sin \frac{\pi}{2} \right] = 35.3 \text{ K} \cdot \text{ft}$$

From Eq. 21.18,

$$T_c = 304 \left[ \frac{\pi}{8} \left( \cos \frac{\pi}{2} - 1 \right) + \frac{\pi}{8} + \frac{1}{24} \sin \pi - 0.11 \cos \frac{\pi}{2} \right] = 0$$

3. For the section at  $D$ ,  $\theta = \pi/4$ .

$$M_D = 304 \left[ \frac{\pi}{8} \sin \frac{\pi}{4} - \frac{1}{6} \left( 1 + \cos^2 \frac{\pi}{4} \right) - 0.11 \sin \frac{\pi}{4} \right] = -15.2 \text{ K} \cdot \text{ft}$$

$$T_D = 304 \left[ \frac{\pi}{8} \left( \cos \frac{\pi}{4} - 1 \right) + \frac{\pi}{16} + \frac{1}{24} \sin \frac{\pi}{2} - 0.11 \cos \frac{\pi}{4} \right] = 13.7 \text{ K} \cdot \text{ft}$$

4. Maximum shearing force occurs at the supports.

$$V_A = 0.39 w_u r^2 = 0.39(0.304)(100) = 11.9 \text{ K}$$

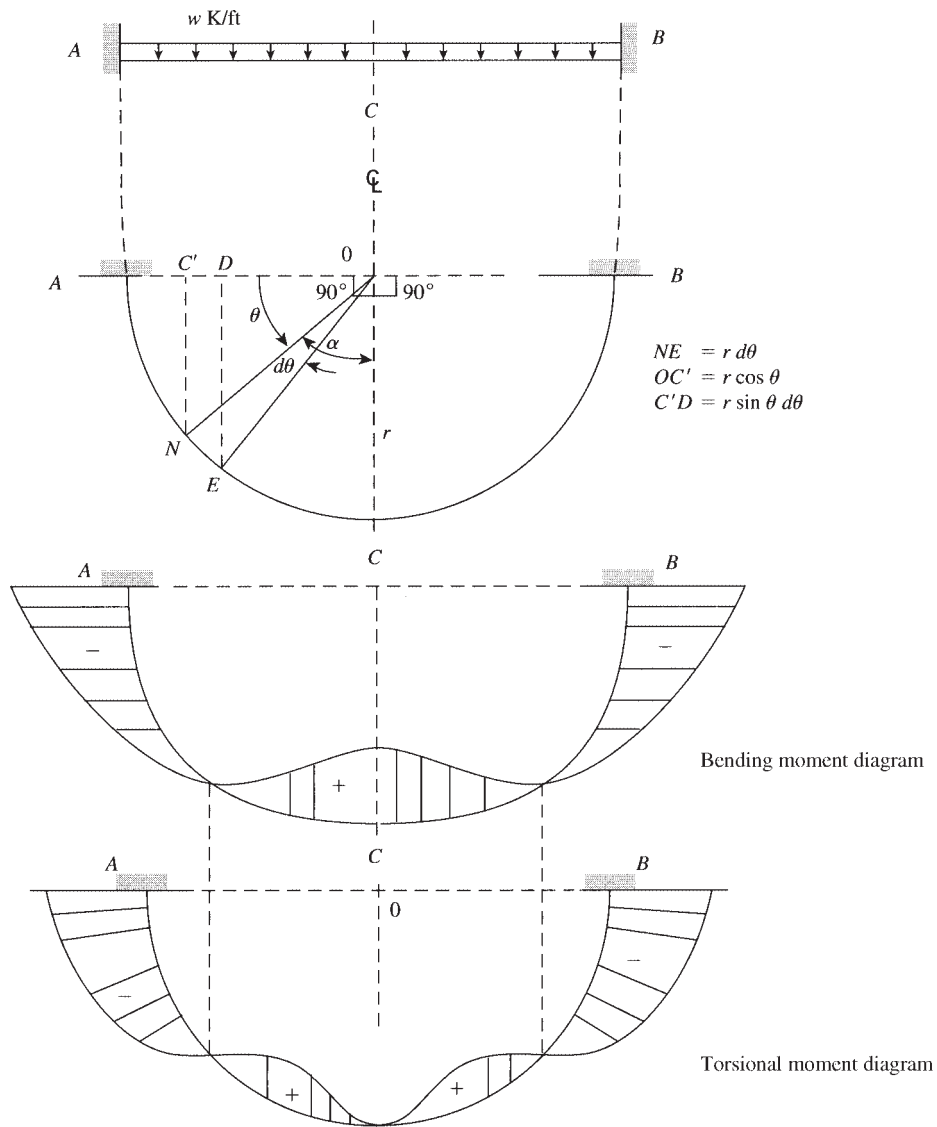
Maximum positive moment occurs at  $C$ , whereas the maximum negative moment occurs at the supports.

$$M_A = -\frac{w_u r^3}{3} = -\frac{304}{3} = 101.3 \text{ K} \cdot \text{ft}$$

5. Design the critical sections for shear, bending, and torsional moments, as explained in Example 21.1.

**21.4 FIXED-END SEMICIRCULAR BEAM UNDER UNIFORM LOADING**

The previous section dealt with a semicircular beam fixed at both ends and subjected to a variable distributed load. If the load is uniform, then the beam will be subjected to a uniformly distributed load  $w$  K/ft, as shown in Fig. 21.6. The forces in the curved beam can be determined as follows:



**Figure 21.6** Semicircular beam under uniform load.

1. Shearing force at A:

$$V_A = V_B = \int_0^{\pi/2} wr d\theta = wr \frac{\pi}{2} = 1.57 wr \quad (21.21)$$

2. Bending moment at A:

$$M_A = M_B = \int_0^{\pi/2} w(r d\theta) \times (r \sin \theta) = wr^2 \quad (21.22)$$

3. Bending moment at any section  $N$  on the curved beam when the torsional moment at  $A$  ( $T_A$ ) acts clockwise:

$$\begin{aligned} M_N &= V_A(r \sin \theta) - M_A \cos \theta + T_A \sin \theta - \int_0^\theta (wr \, d\alpha)[r \sin(\theta - \alpha)] \\ &= \frac{\pi}{2} wr^2 \sin \theta - wr^2 \cos \theta + T_A \sin \theta - [wr^2 - wr^2 \cos \theta] \\ M_N &= wr^2 \left[ \frac{\pi}{2} \sin \theta - 1 \right] + T_A \sin \theta \end{aligned} \quad (21.23)$$

4. Torsional moment at any section  $N$ :

$$\begin{aligned} T_N &= -V_A r(1 - \cos \theta) + M_A \sin \theta + T_A \cos \theta + \int_0^\theta (wr \, d\alpha)r[1 - \cos(\theta - \alpha)] \\ &= -\frac{\pi}{2} wr^2 + \frac{\pi}{2} wr^2 \cos \theta + T_A \cos \theta + M_A \sin \theta + wr^2 \theta - wr^2 \sin \theta \end{aligned}$$

Substitute  $M_A = wr^2$ :

$$T_N = wr^2 \left[ \frac{\pi}{2} \cos \theta - \frac{\pi}{2} + \theta \right] + T_A \cos \theta \quad (21.24)$$

5. The strain energy expression was given in the previous section:

$$U = \int \frac{M_N^2 ds}{2EI} + \int \frac{T_N^2 ds}{2GJ} \quad (21.25)$$

To obtain  $T_A$ , differentiate  $U$  with respect to  $T_A$ :

$$\frac{\delta U}{\delta T_A} = \int \frac{M_N}{EI} \times \frac{dM_N}{dT_A}(r \, d\theta) + \int \frac{T_N}{GJ} \times \frac{dT_N}{dT_A} \times (r \, d\theta) = 0$$

$$\frac{dM_N}{dT_A} = \sin \theta \quad \text{and} \quad \frac{dT_N}{dT_A} = \cos \theta \quad (\text{from the preceding equations})$$

$$\begin{aligned} \frac{\delta U}{\delta T_A} &= \frac{r}{EI} \int_0^{\pi/2} \left[ wr^2 \left( \frac{\pi}{2} \sin - 1 \right) + T_A \sin \theta \right] \sin \theta \, d\theta \\ &\quad + \frac{r}{GJ} \int_0^{\pi/2} \left[ wr^2 \left( \frac{\pi}{2} \cos \theta - \frac{\pi}{2} + \theta \right) + T_A \cos \theta \right] \cos \theta \, d\theta = 0 \end{aligned}$$

The integration of the preceding equation produces the following:

$$\frac{\delta U}{\delta T_A} = \frac{r}{EI} \left[ wr^2 \left( \frac{\pi^2}{8} - 1 \right) + \frac{\pi}{4} T_A \right] + \frac{r}{GJ} \left[ wr^2 \left( \frac{\pi^2}{8} - 1 \right) + \frac{\pi}{4} T_A \right] = 0$$

and

$$r \left[ wr^2 \left( \frac{\pi^2}{8} - 1 \right) + \frac{\pi}{4} T_A \right] \left( \frac{EI}{GJ} + 1 \right) = 0$$

Because  $EI/GJ$  is not equal to zero,

$$wr^2 \left( \frac{\pi^2}{8} - 1 \right) + \frac{\pi}{4} T_A = 0$$

and

$$T_A = -wr^2 \left( \frac{4}{\pi} \right) \left( \frac{\pi^2}{8} - 1 \right) = -0.3 wr^2 \quad (21.26)$$

6. Substitute  $T_A$  in Eq. 21.23:

$$\begin{aligned} M_N &= wr^2 \left[ \left( \frac{\pi}{2} \sin \theta - 1 \right) - \left( \frac{\pi}{2} - \frac{4}{\pi} \right) \sin \theta \right] \\ &= wr^2 \left( \frac{4}{\pi} \sin \theta - 1 \right) \end{aligned} \quad (21.27)$$

$$\begin{aligned} T_N &= wr^2 \left[ \left( \frac{\pi}{2} \cos \theta + \theta - \frac{\pi}{2} \right) - \left( \frac{\pi}{2} - \frac{4}{\pi} \right) \cos \theta \right] \\ &= wr^2 \left( \theta - \frac{\pi}{2} + \frac{4}{\pi} \cos \theta \right) \end{aligned} \quad (21.28)$$

The values of the bending and torsional moments at any section  $N$  are independent of  $\lambda$  ( $1 = EI/GJ$ ).

7. Bending and torsional moments at midspan, section  $C$ , can be found by substituting  $\theta = \pi/2$  in Eqs. 21.27 and 21.28:

$$M_c = wr^2 \left( \frac{4}{\pi} - 1 \right) = 0.273 wr^2 \quad (21.29)$$

$$T_c = wr^2 \left( \frac{\pi}{2} - \frac{\pi}{2} + 0 \right) = 0 \quad (21.30)$$

## 21.5 CIRCULAR BEAM SUBJECTED TO UNIFORM LOADING

The previous section dealt with a semicircular beam subjected to a uniformly distributed load. The forces acting on the beam at any section vary with the intensity of load, the span (or the radius of the circular beam), and the angle  $\alpha$  measured from the centerline axis of the beam.

Considering the general case of a circular beam fixed at both ends and subjected to a uniform load  $w$  (K/ft), as shown in Fig. 21.7, the bending and torsional moments can be calculated from the following expressions:

1. The moment at the centerline of the beam,  $M_c$ , can be derived using the strain energy expression, Eq. 21.25, and can be expressed as follows:

$$M_c = \frac{wr^2}{K_4} [\lambda(K_1 + K_2 - K_3) + (K_1 - K_2)] \quad (21.31)$$

where

$$\begin{aligned} \lambda &= EI/GJ \\ K_1 &= 2(2 \sin \theta - \theta) \\ K_2 &= 2 \sin \theta \cos \theta = \sin 2\theta \\ K_3 &= 4\theta \cos \theta \\ K_4 &= 2\theta(\lambda + 1) - (\lambda - 1) \sin 2\theta \\ 2\theta &= \text{total central angle of the ends of the beam, angle } AOB \text{ (Fig. 19)} \end{aligned}$$

The torsional moment at the centerline section,  $T_c$ , is 0.



Curved-beam bridge, Washington, D.C.

2. The moment at any section  $N$  on the curved beam where  $ON$  makes an angle  $\alpha$  with the centerline axis (Fig. 21.7) is

$$M_N = M_c \cos \alpha - wr^2(1 - \cos \alpha) \quad (21.32)$$

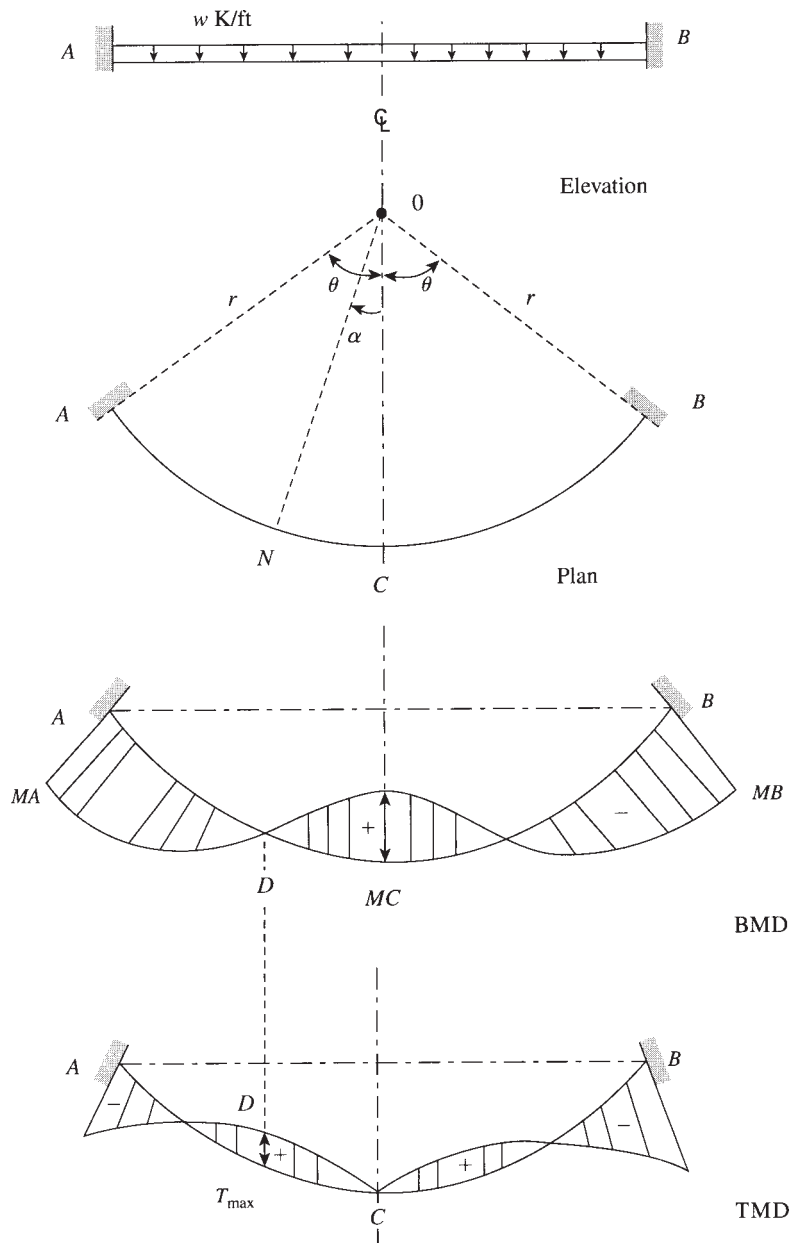
3. The torsional moment at any section  $N$  on the curved beam as a function of the angle  $\alpha$  was derived earlier:

$$T_N = M_c \sin \alpha - wr^2(\alpha - \sin \alpha) \quad (21.33)$$

4. To compute the bending moment and torsional moment at the supports, substitute  $\theta$  for  $\alpha$  in the preceding equations:

$$M_A = M_c \cos \theta - wr^2(1 - \cos \theta) \quad (21.34)$$

$$T_A = M_c \sin \theta - wr^2(\theta - \sin \theta) \quad (21.35)$$



**Figure 21.7** Circular beam subjected to uniform load, showing the bending moment diagram (BMD) and the torsional moment diagram (TMD).

**Example 21.3**

A curved beam has a quarter-circle shape in plan with a 10 ft radius. The beam has a rectangular section with the ratio of the long to the short side of 2.0 and is subjected to a factored load of 8 K/ft. Determine the bending and torsional moments at the centerline of the beam, supports, and maximum values.

**Solution**

1. For a rectangular section with  $y/x = 2$ ,  $\lambda = EI/GJ = 3.39$  (Table 21.2).
2. The bending and torsional moments can be calculated using Eqs. 21.31 through 21.35 for  $\theta = \pi/4$ . From Eq. 21.31,

$$K_1 = 2 \left( 2 \sin \frac{\pi}{4} - \frac{\pi}{4} \right) = 1.2576$$

$$K_2 = \sin \frac{\pi}{2} = 1.0$$

$$K_3 = 4 \left( \frac{\pi}{4} \right) \cos \frac{\pi}{4} = 2.2214$$

$$K_4 = 2 \left( \frac{\pi}{4} \right) (3.39 + 1) - (3.39 - 1) \sin \frac{\pi}{2} = 4.506$$

$$\begin{aligned} M_c &= \frac{wr^2}{4.506} [3.39(1.2576 + 1.0 - 2.2214) + (1.2576 - 1.0)] \\ &= 0.0844 wr^2 \end{aligned}$$

For  $w = 8 \text{ K}\cdot\text{ft}$  and  $r = 10 \text{ ft}$ ,  $M_c = 64 \text{ K}\cdot\text{ft}$ ;  $T_c = 0$

$$3. \quad M_N = M_c \cos \alpha - wr^2 (1 - \cos \alpha) = wr^2 (1.08 \cos \alpha - 1)$$

$$T_N = M_c \sin \alpha - wr^2 (\alpha - \sin \alpha) = wr^2 (1.08 \sin \alpha - \alpha)$$

For the moments at the supports,  $\alpha = \theta = \pi/4$ .

$$\begin{aligned} M_A &= wr^2 \left( 1.08 \cos \frac{\pi}{4} - 1 \right) = -0.236 wr^2 \\ &= -0.236 \times 8 \times (10)^2 = -189 \text{ K}\cdot\text{ft} \end{aligned}$$

$$T_A = wr^2 \left( 1.08 \sin \frac{\pi}{4} - \frac{\pi}{4} \right) = 0.022 wr^2 = -17.4 \text{ K}\cdot\text{ft}$$

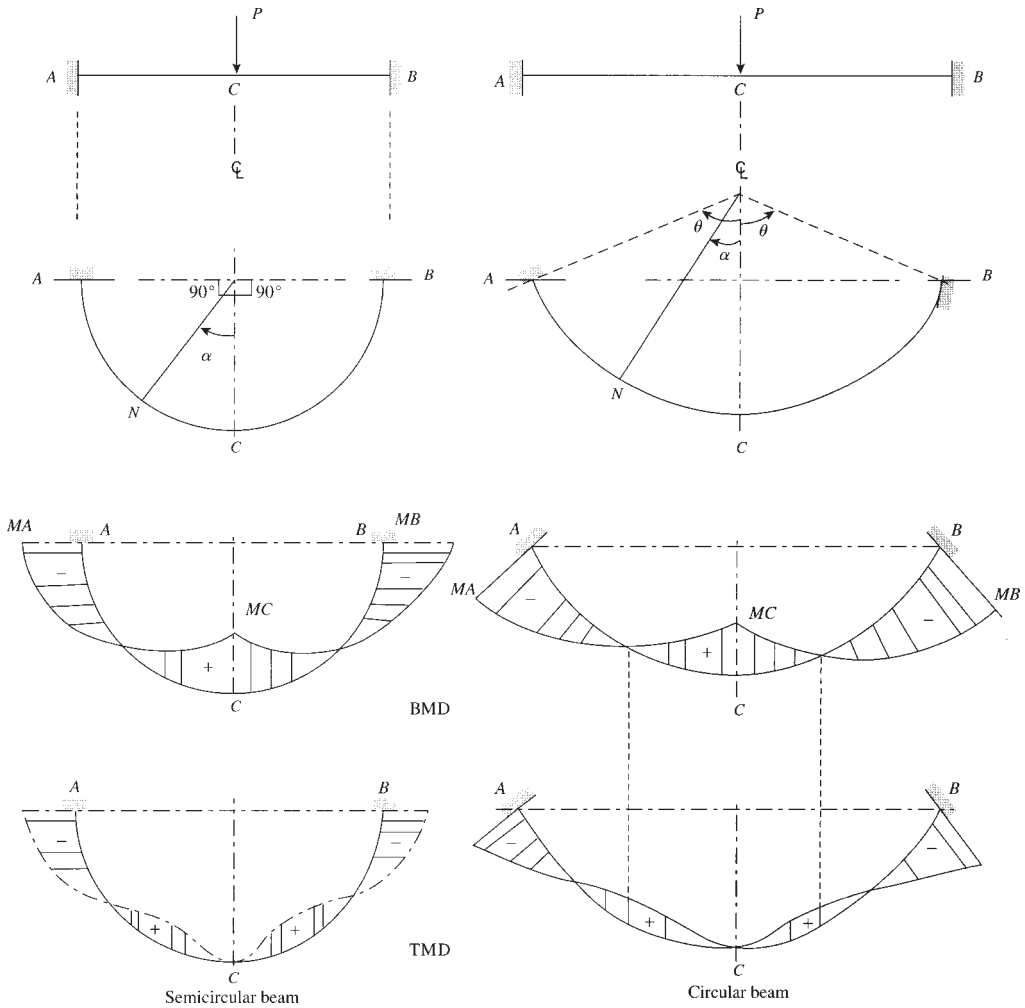
For  $M_N = 0$ ,  $1.08 \cos \alpha - 1 = 0$ , or  $\cos \alpha = 0.926$  and  $\alpha = 22.2^\circ = 0.387 \text{ rad}$ . To calculate  $T_{N,\max}$ , let  $dT_N/d\alpha = 0$ , or  $1.08 \cos \alpha - 1 = 0$ . Then  $\cos \alpha = 0.926$  and  $\alpha = 22.2^\circ$ .

$$T_N(\max) = wr^2 (1.08 \sin 22.2 - 0.387) = 0.0211 wr^2$$

$$T_{N,\max} = 0.0211 \times 800 = 16.85 \text{ K}\cdot\text{ft}$$

**21.6 CIRCULAR BEAM SUBJECTED TO A CONCENTRATED LOAD AT MIDSPAN**

If a concentrated load is applied at the midspan of a circular beam, the resulting moments vary with the magnitude of the load, the span, and the coefficient  $\lambda = EI/GJ$ . Considering the general case of a circular beam fixed at both ends and subjected to a concentrated load  $P$  at midspan (Fig. 21.8), the bending and torsional moments can be calculated from the following expressions:



**Figure 21.8** Circular beam subjected to a concentrated load at midspan, showing the bending moment diagram (BMD) and the torsional moment diagram (TMD).

1. The moment at the centerline of the beam, section  $C$ , can be expressed as follows:

$$M_c = \frac{\lambda(2 - 2 \cos \theta - \sin^2 \theta) + \sin^2 \theta}{2\theta(\lambda + 1) - (\lambda - 1)\sin 2\theta} (Pr)$$

$$M_c = \frac{Pr}{K_3} (\lambda K_1 + K_2) \tag{21.36}$$

where

$$\lambda = EI/GJ$$

$$K_1 = (2 - 2 \cos \theta - \sin^2 \theta)$$

$$K_2 = \sin^2 \theta$$

$$K_3 = 2\theta(\lambda + 1) - (\lambda - 1) \sin^2 \theta$$

The torsional moment at the centerline is  $T_c = 0$ .



2. The bending and torsional moments at any section  $N$  on the curved beam where  $ON$  makes an angle  $\alpha$  with the centerline axis are calculated as follows:

$$M_N = M_c \cos \alpha - \left(\frac{P}{2}r\right) \sin \alpha \quad (21.37)$$

$$T_N = M_c \sin \alpha - \left(\frac{P}{2}r\right) (1 - \cos \alpha) \quad (21.38)$$

3. To compute the bending and torsional moments at the supports, substitute  $\theta$  for  $\alpha$ .

$$M_A = M_c \cos \theta - \left(\frac{P}{2}r\right) \sin \theta \quad (21.39)$$

$$T_A = M_c \sin \theta - \left(\frac{P}{2}r\right) (1 - \cos \theta) \quad (21.40)$$

#### Example 21.4

Determine the bending and torsional moments of the quarter-circle beam of Example 21.3 if  $\lambda = 1.0$  with the beam subjected to a concentrated load at midspan of  $P = 20$  K.

#### Solution

1. Given:  $\lambda = 1.0$  and  $\theta = \pi/4$ . Therefore,

$$M_c = \left(\frac{Pr}{2}\right) \left(\frac{1 - \cos \theta}{\theta}\right)$$

(Eq. 21.36) and  $T_c = 0$ . For  $\theta = \pi/4$ ,

$$M_c = 0.187 Pr = 0.187(20 \times 10) = 37.4 \text{ K} \cdot \text{ft}$$

2. From Eqs. 21.39 and Eqs. 21.40,

$$\begin{aligned} M_A &= 0.187 Pr \cos \frac{\pi}{4} - \frac{Pr}{2} \sin \frac{\pi}{4} = -0.22 Pr \\ &= -0.22 \times (200) = -44 \text{ K} \cdot \text{ft} \end{aligned}$$

$$\begin{aligned} T_A &= 0.187 Pr \sin \frac{\pi}{4} - 0.5 Pr \left(1 - \cos \frac{\pi}{4}\right) = -0.0142 Pr \\ &= -0.0142 \times 200 = -2.84 \text{ K} \cdot \text{ft} \end{aligned}$$

3.  $M_N = 0$  when

$$M_c \cos \alpha - \frac{Pr}{2} \sin \alpha = 0$$

$$0.187 Pr \cos \alpha - 0.5 Pr \sin \alpha = 0$$

$$\tan \alpha = 0.374 \quad \text{and} \quad \alpha = 20.5^\circ \quad (\text{Eq. 21.37})$$

$T_n = 0$  when  $M_c \sin \alpha - (P/2)r(1 - \cos \alpha) = 0$  (Eq. 21.38), from which  $\alpha = 37.7^\circ$ .

4. To compute  $T_{\max}$ , let  $dT_N/d\alpha = 0$  (Eq. 21.38).

$$0.187 Pr \cos \alpha - 0.5 Pr \sin \alpha = 0, \quad \tan \alpha = 0.374$$

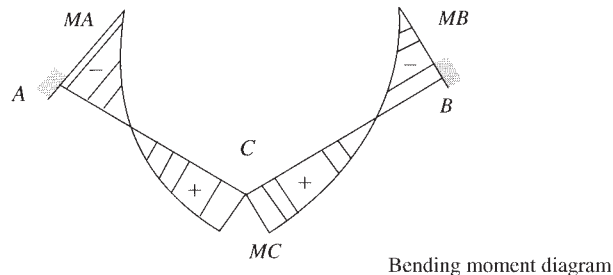
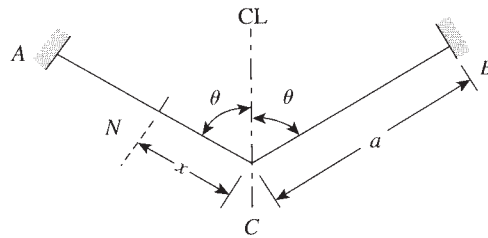
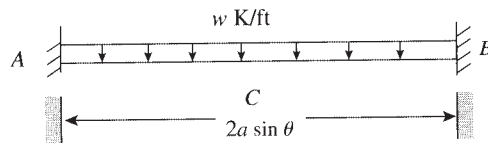
and  $\alpha = 20.5^\circ$ . Substitute  $\alpha = 20.5^\circ$  in Eq. 21.38 to get  $T_{\max} = 0.035Pr = 7 \text{ K} \cdot \text{ft}$ .

### 21.7 V-SHAPE BEAMS SUBJECTED TO UNIFORM LOADING

Beams that have a V-shape in plan and are subjected to loads normal to the plane of the beam may be analyzed using the *strain–energy principles*. Figure 21.9 shows a typical bending moment diagram for a V-shape beam subjected to a uniform load  $w$ . Considering the general case of a V-shape beam fixed at both ends and subjected to a uniform load  $w$  (K/ft), the bending and torsional moments can be calculated from the following expressions:

1. The moment at the centerline of the beam, section C, is calculated as follows:

$$M_c = (wa^2) \left[ \frac{\sin^2 \theta}{6 (\sin^2 \theta + \lambda \cos^2 \theta)} \right] \quad (21.41)$$



**Figure 21.9** V-shape beam under uniform load.



90° V-shape beams, London, Ontario, Canada.

where

$$\lambda = EI/GJ$$

$a$  = half total length of beam (length  $AC$ )

$\theta$  = half angle between two sides of V-shape beam

The torsional moment at the centerline section is

$$T_c = \frac{M_c}{\sin \theta} \cos \theta = M_c \cot \theta \quad (21.42)$$

2. The bending and torsional moments at any section  $N$  along half the beam  $AC$  or  $BC$  at a distance  $x$  measured from section  $C$  are calculated as follows:

$$M_N = M_c - w \frac{x^2}{2} \quad (21.43)$$

$$T_N = T_c = \frac{M_c}{\sin \theta} \times \cos \theta = M_c \cot \theta \quad (21.44)$$

To compute the moments at the supports, let  $x = a$ . Then

$$M_A = M_c - w \frac{a^2}{2} \quad T_A = T_c = M_c \cot \theta$$

### Example 21.5

Determine the bending and torsional moments in a V-shape beam subjected to a uniform load of 6 K/ft. The length of half the beam is  $a = 10$  ft and the angle between the V-shape members is  $2\theta = \pi/2$ . The beam section is rectangular with a ratio of long side to short side of 2.



Apartment building.

**Solution**

1. For a rectangular section with the sides ratio,  $y/x = 2$ ,  $\lambda = 3.39$ . For this beam  $\theta = \pi/4$ .

$$M_c = \frac{wa^2}{6} \left( \frac{\sin^2 \theta}{\sin^2 \theta + \lambda \cos^2 \theta} \right)$$

$$M_c = \frac{wa^2}{6} \left( \frac{0.5}{0.5 + 3.39 \times 0.5} \right) = 0.038 wa^2$$

$$= 0.038 \times 6(10)^2 = 22.8 \text{ K} \cdot \text{ft}$$

- 2.

$$M_A = M_c - w \frac{a^2}{2} = 0.038 wa^2 - 0.5 wa^2 = -0.462 wa^2$$

$$= -277.2 \text{ K} \cdot \text{ft}$$

$$M_N = 0 \quad \text{when} \quad M_c - w \frac{x^2}{2} = 0$$

or  $0.038 wa^2 - 0.5 wx^2 = 0$ , so  $x = 0.276a = 2.76 \text{ ft}$  measured from  $c$ .

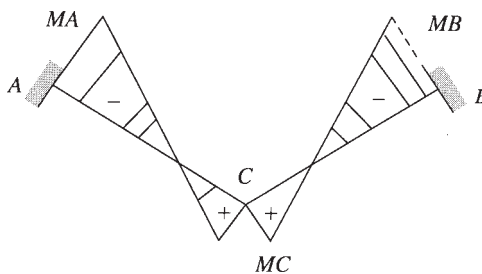
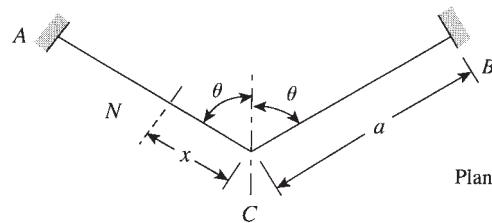
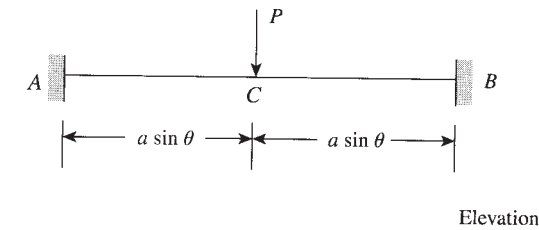
3.  $T_A = 0.038 wa^2 = 0.038 \times 600 = 22.8 \text{ K} \cdot \text{ft}$   
 $T_C = M_C \cot \theta$

### 21.8 V-SHAPE BEAMS SUBJECTED TO A CONCENTRATED LOAD AT THE CENTERLINE OF THE BEAM

The general equations for computing the bending and torsional moments in a V-shape beam fixed at both ends and subjected to a concentrated load  $P$  at the centerline of the beam (Fig. 21.10) are as follows:

1. The moment at the centerline of the beam, section  $C$ , for any value of  $\lambda$ , is

$$M_c = \left( \frac{Pa}{4} \right) \left( \frac{\sin^2 \theta}{\sin^2 \theta + \lambda \cos^2 \theta} \right) \quad (21.45)$$



**Figure 21.10** V-shape beam under concentrated load.

where

$$\lambda = EI/GJ$$

$a$  = half total length of beam (part  $AB$  or  $BC$ )

$\theta$  = half angle between two sides of V-shape beam

The torsional moment at the centerline section is

$$T_c = \frac{M_c}{\sin \theta} \cos \theta = M_c \cot \theta \quad (21.46)$$

2. The bending and torsional moments at any section  $N$  along half the beam  $AC$  or  $BC$  at a distance  $x$  measured from  $C$  are calculated as follows:

$$M_N = M_c - \frac{Px}{\frac{1}{2}} \quad (21.47)$$

$$T_N = T_c = M_c \cot \theta \quad (21.48)$$

The moments at the supports are determined by assuming  $x = a$ :

$$M_A = M_c - \frac{Pa}{\frac{1}{2}} \quad (21.49)$$

$$T_A = T_c = M_c \cot \theta \quad (21.50)$$

### Example 21.6

Determine the bending and torsional moments in a V-shape beam subjected to a concentrated load  $P = 30$  K acting at the centerline of the beam. Given:  $\theta = \pi/4$ ,  $y/x = 2.0$ , and  $a = 12$  ft.

#### Solution

1. For a rectangular section with  $y/x = 2.0$ ,  $\lambda = 3.39$ .

- 2.

$$M_c = \frac{Pa}{4} \left( \frac{\sin^2 \pi/4}{\sin^2 \pi/4 + 3.39 \cos^2 \pi/4} \right) = 0.057(Pa)$$

$$= 0.057 \times 30 \times 12 = 20.5 \text{ K} \cdot \text{ft}$$

$$M_A = M_c - \frac{Pa}{\frac{1}{2}} = (0.057 - 0.5)Pa = -0.443(Pa)$$

$$= -0.443 \times 360 = -159.5 \text{ K} \cdot \text{ft}$$

$$M_N = 0 \quad \text{when} \quad M_c - \frac{Px}{\frac{1}{2}} = 0$$

Hence,  $0.057Pa - 0.5Px = 0$  and  $x = 0.114a = 0.114 \times 12 = 1.37$  ft measured from  $c$ .

3.  $T_A = T_c = T_N = M_c \cot \frac{\pi}{4} = 0.057(Pa) = 20.5 \text{ K} \cdot \text{ft}$

### Example 21.7

Determine the bending and torsional moments in the beam of Example 21.6 if the angle  $\theta$  is  $\pi/2$  (a straight beam fixed at both ends).

**Solution**

Given  $\theta = \pi/2$  and the span  $L = 2a =$  the distance between the two supports. The bending moment at the centerline is

$$M_c = \frac{Pa}{4} \left( \frac{1}{1} \right) = \frac{Pa}{4} = \frac{PL}{8} = +90 \text{ K} \cdot \text{ft}$$

$$M_A = M_c - \frac{Pa}{2} = \frac{PL}{8} - \frac{P}{2} \left( \frac{L}{2} \right) = -\frac{PL}{8} = -90 \text{ K} \cdot \text{ft}$$

$$T_A = T_c = 0$$

These values are similar to those obtained from the structural analysis of the fixed-end beam subjected to a concentrated load at midspan.

**Example 21.8**

The beam shown in Fig. 21.11 has a V-shape in plan and carries a uniform dead load of 3.5 k/ft and a live load of 3 K/ft. The inclined length of half the beam is  $a = 10$  ft and  $\theta = 60^\circ$ . Design the beam for shear, bending, and torsional moments using  $f'_c = 4$  ksi and  $f_y = 60$  ksi.

**Solution**

- $w_u = 1.2D + 1.6L = 1.2 \times 3.5 + 1.6 \times 3 = 9.0$  K/ft.
- Assuming a rectangular section with a ratio of long to short side of  $y/x = 1.75$ , the value of  $\lambda$  is 2.77 (from Table 21.2). For  $\theta = 60^\circ = \pi/3$ ,

$$M_c = \frac{w_u a^2 \sin^2 \theta}{6(\sin^2 \theta + \lambda \cos^2 \theta)} = \frac{9(100)(0.75)}{6(0.75 + 2.77 \times 0.25)} = +78 \text{ K} \cdot \text{ft}$$

$$M_A = M_c - w_u \frac{a^2}{2} = 78 - 9 \left( \frac{100}{2} \right) = -372 \text{ K} \cdot \text{ft}$$

$$T_A = M_c \cot \theta = 78 \times 0.577 = 45 \text{ K} \cdot \text{ft} = 540 \text{ K} \cdot \text{in.}$$

$$T_c(\text{at } x = 0) = M_c \cot \theta = 45 \text{ K} \cdot \text{ft} = 540 \text{ K} \cdot \text{in.}$$

$$V_A = 9 \times 10 = 90 \text{ K}$$

The bending moment is zero at  $M_N = 0 = M_c - w_u x^2/2$ . Hence,  $78 - \frac{9}{2}x^2 = 0$  and  $x = 4.16$  ft measured from  $c$ . The bending moment diagram is shown in Fig. 21.11.

- Design for a bending moment,  $M_u$ , equal to  $-372$  K·ft.
  - For  $f'_c = 4$  ksi,  $f_y = 60$  ksi,  $\rho_{\max} = 0.0018$ , choose  $\rho = 0.015$ ,  $R_u = 702$  psi and  $\phi = 0.9$  (Appendix A).

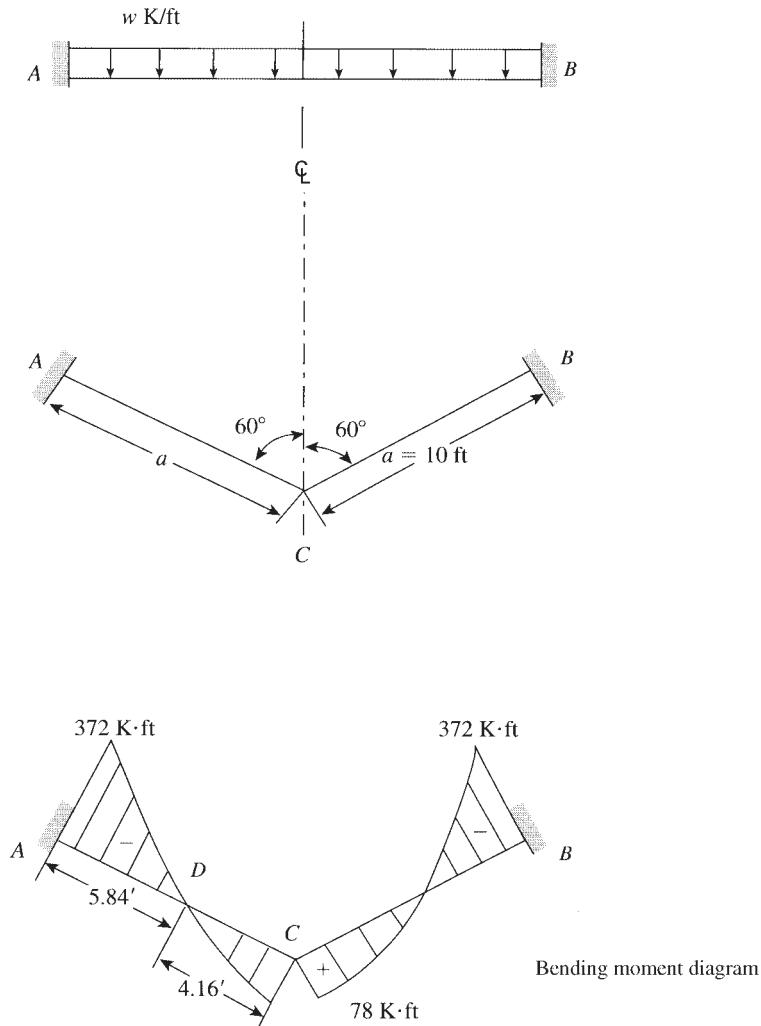
$$bd^2 = \frac{M_u}{R_u} = \frac{372 \times 12}{0.705} = 6332 \text{ in.}^3$$

For a ratio,

$$\frac{y}{x} = \frac{d+3}{b} = 1.75$$

as assumed, then  $d = 21.4$  in. and  $b = 13.8$  in. Use a section  $14 \times 24$  in.

$$A_s = \rho_{\max} bd = 0.015(14 \times 21.4) = 4.5 \text{ in.}^2$$



**Figure 21.11** Example 21.8.

- b.** For the section at midspan,  $M_u = 78 \text{ K}\cdot\text{ft}$  and actual  $d = 21.5 \text{ in.}$

$$R_u = \frac{M_u}{bd^2} = \frac{78,000 \times 12}{14 \times (21.5)^2} = 145 \text{ psi}$$

$$\rho < \rho_{\min} = 0.0033$$

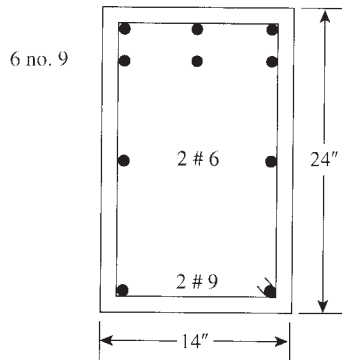
$$\text{Use } A_s = 0.0033 \times 14 \times 21.5 = 1.0 \text{ in.}^2.$$

- c.** Design for torsional moment and shear:  $T_u = 45 \text{ K}\cdot\text{ft}$  for all sections.

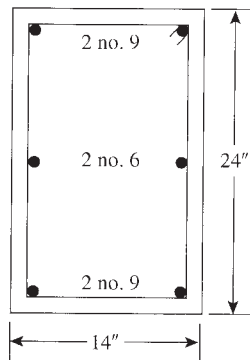
$$V_u(\text{at distance } d) = 90 - \frac{21.5}{12} \times 9 = 74.0 \text{ K}$$

The design procedure will be similar to that of Example 21.1. Details of the final section are shown in Fig. 21.12.

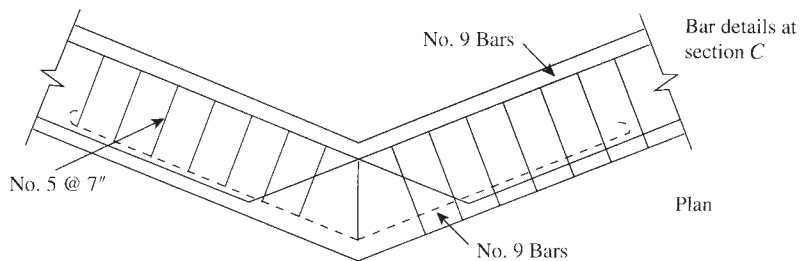




Section at A



Section at C



**Figure 21.12** Example 21.8.

**SUMMARY**

**Sections 21.1–21.5**

In a curved beam in plan, the center of gravity of normal loads lies outside the line joining the supports developing torsional moments. The analysis of uniformly loaded circular beams is presented in these sections.

**Section 21.6**

The analysis of circular beams subjected to concentrated loads is presented in this section.

**Section 21.7**

V-shaped beams subjected to gravity loads may be analyzed using the strain–energy principles. Equations to calculate the torsional moments of these types of beams are presented.

**REFERENCES**

1. B. J. Wilson and J. F. Quereau. *A Simple Method of Determining Stress in Curved Flexural Members*. Circular 16. University of Illinois Engineering Exp. Station, Urbana-Champaign, 1925.
2. S. Timoshenko. “Bending Stresses in Curved Tubes of Rectangular Cross Sections.” *Transactions of ASME* 45 (1923).
3. S. Timoshenko. *Strength of Materials*. D. Van Nostrand, New York, 1930.
4. R. J. Roark and W. C. Young. *Formulas for Stress and Strain*, 5th ed. McGraw-Hill, New York, 1975, pp. 209–285.

**PROBLEMS**

- 21.1 A circular beam is supported on six equally spaced columns, and its centerline lies on a circle 20 ft in diameter. The beam carries a uniform dead load of 9.8 K/ft and a live load of 5 K/ft. Design the beam using  $f'_c = 4$  ksi,  $f_y = 60$  ksi, and  $b = 14$  in.
- 21.2 Design a semicircular beam fixed on both ends. The center of columns lies on a circle 12 ft in diameter. The beam carries uniform dead and live loads of 4.9 and 3 K/ft, respectively. Use  $f'_c = 4$  ksi,  $f_y = 60$  ksi, and  $b = 20$  in.
- 21.3 Determine the factored bending and torsional moment at sections *C* and *D* of the fixed-end beam shown in Fig. 21.5 if the diameter of the circle is 30 ft. The beam is part of a floor slab that carries a uniform dead load (including its own weight) of 126 psf and a live load of 120 psf.
- 21.4 A quarter-circle cantilever beam has a radius of 8 ft and carries a uniform dead load of 6.4 K/ft and a concentrated live load of 4.25 K at its free end. Design the beam using  $f'_c = 4$  ksi,  $f'_y = 60$  ksi, and  $b = 14$  in.
- 21.5 Design the beam shown in Fig. 21.11 if the inclined length of half the beam is  $a = 8$  ft. The beam has a  $60^\circ$  V-shape in plan and carries uniform dead and live loads of 3.8 and 4 K/ft. Assume the ratio of the long to the short side of the rectangular section is 2. Use  $f'_c = 4$  ksi and  $f_y = 60$  ksi.

# CHAPTER 22

## PRESTRESSED CONCRETE BRIDGE DESIGN BASED ON AASHTO LRFD BRIDGE DESIGN SPECIFICATIONS



Benicia-Martinez Bridge, California.

### 22.1 INTRODUCTION

In the United States highway bridges are generally designed based on AASHTO LRFD bridge design specifications and railroad bridges, are designed based on specifications of the American Railway Engineering Association (AREA). This chapter covers bridge designs in accordance with the American Association of State Highway and Transportation Officials (AASHTO) LRFD *Bridge Design Specification*, 7th edition [1]. The design provisions of these specifications employ the Load and Resistance Factor Design (LRFD) methodology. The factors have been developed from the theory of reliability based on current statistical knowledge of loads and structural performance. A written form of bridge design specifications had started in the early 1920s, and the current form of specifications has developed for over 90 years. Like all other codes and specifications, the AASHTO specifications set forth as the minimum requirements consistent with the current engineering practice and are applicable to ordinary highway bridges up to span lengths of 500 ft.

This chapter is intended to provide guidance on the AASHTO LRFD Bridge Design Specifications, and the readers are assumed to have knowledge of the reinforced and prestressed concrete design. The scope is limited to short- and medium-span bridges with a practical maximum span length of about 180 ft. Girder bridges are the most numerous of all highway bridges in the United States and are important structures because they are used so frequently. Bridge structures of span length up to 250 ft comprise approximately 80% of the U.S. bridge inventory and are the most common bridges designed by practitioners [2]. Construction methods of short- and medium-span precast concrete girder bridges usually consist of building with precast pretensioned beams that are transported to a site and erected. A cast-in-place deck slab is added as either noncomposite or composite to provide for continuity.

## 22.2 TYPICAL CROSS SECTIONS

Typical cross sections of precast prestressed girders commonly used for short- and medium-span bridges have been developed and standardized by AASHTO and PCI for highway bridges. The dimensions, sectional properties, and span range of these standard AASHTO-PCI girders are introduced in this section.

### 22.2.1 AASHTO Solid and Voided Slab Beams

Solid and voided slab beams (Fig. 22.1) are typically used for short-span bridges ranging up to 55 ft based on simple span, HS-25 (highway semitrailer with the first two axles weighing 25 tons) loading and  $f'_c = 7000$  psi. Dimensions and properties of AASHTO solid and voided slab beams are given in Tables 22.1 and 22.2, respectively.

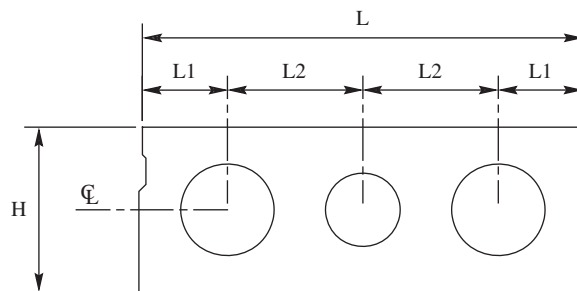


Figure 22.1 Cross section of AASHTO solid and voided slab beams.

Table 22.1 Dimensions (inches) of AASHTO Solid and Voided Slab

Type	L	H	L1	L2	No. of Voids	D1	D2
SI-36	36	12	—	—	0	—	—
SII-36	36	15	10.5	7.5	2	8	—
SIII-36	36	18	10.5	7.5	2	10	—
SIV-36	36	21	10.0	8.0	2	12	—
SI-48	48	12	—	—	0	—	—
SII-48	48	15	10.0	14.0	3	8	8
SIII-48	48	18	9.5	14.5	3	10	10
SIV-48	48	21	10.0	14.0	3	12	10

Table 22.2 Properties of AASHTO Solid and Voided Slab

Type	Area (in. <sup>2</sup> )	$Y_{\text{bottom}}$ (in.)	Inertia (in. <sup>4</sup> )	Weight (kip/ft)	Max. Span (ft)
SI-36	432	6.0	5,184	0.450	40
SII-36	439	7.5	9,725	0.457	47
SIII-36	491	9.0	16,514	0.511	52
SIV-36	530	10.5	25,747	0.552	57
SI-48	576	6.0	6,912	0.600	42
SII-48	569	7.5	12,897	0.593	49
SIII-48	628	9.0	21,855	0.654	53
SIV-48	703	10.5	34,517	0.732	57

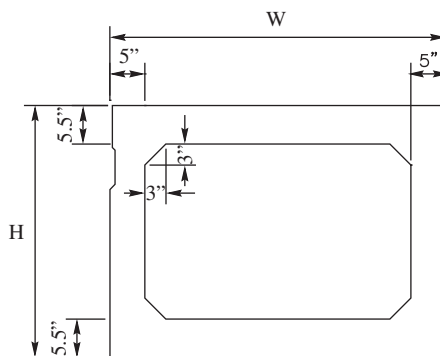
### 22.2.2 AASHTO Box Beams

Box beams (Fig. 22.2) are typically used for short- to medium-span bridges ranging up to 125 ft based on simple span, HS-25 loading, and  $f'_c = 7000$  psi.

Dimensions of AASHTO box beams are given in Table 22.3 and properties are given in Table 22.4.

### 22.2.3 AASHTO I-Beams

I-beams (Fig. 22.3) are the most common composite bridge deck in the United States, typically used for medium-span bridges ranging up to 170 ft based on simple span, HS-25 loading, and  $f'_c = 7000$  psi. Dimensions and properties of I-beams are shown in Tables 22.5 and 22.6, respectively.



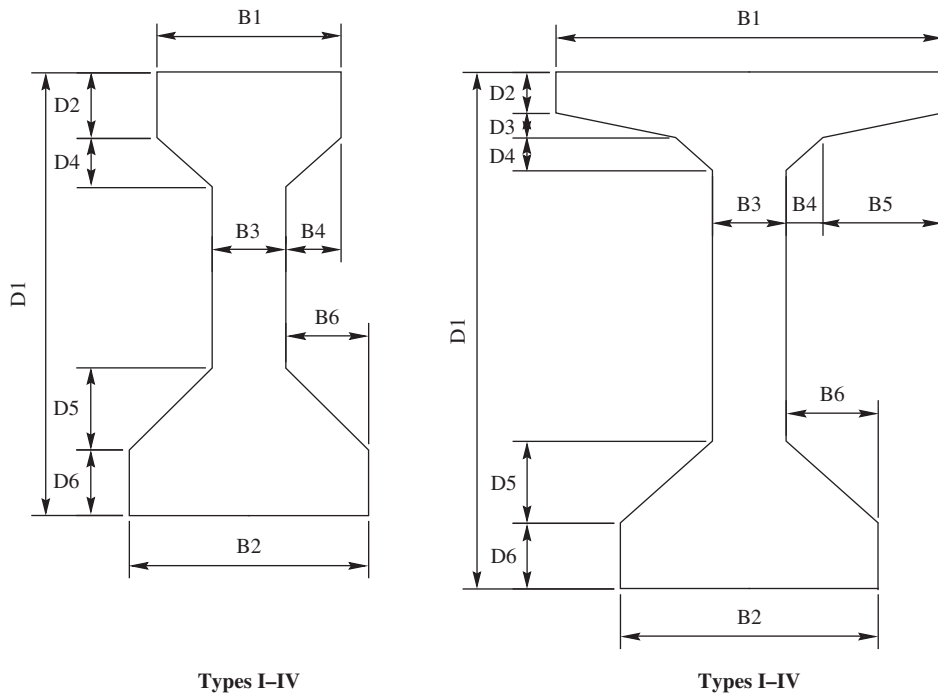
**Figure 22.2** Cross section of AASHTO box beams.

**Table 22.3** Dimensions (in.) of AASHTO Box Beams

Type	<i>W</i>	<i>H</i>
BI-36	36	27
BI-48	48	27
BII-36	36	33
BII-48	48	33
BIII-36	36	39
BIII-48	48	39
BIV-36	36	42
BIV-48	48	42

**Table 22.4** Properties of AASHTO Box Beams

Type	Area (in. <sup>2</sup> )	$Y_{\text{bottom}}$ (in.)	Inertia (in. <sup>4</sup> )	Weight (kip/ft)	Max. Span (ft)
BI-36	560.5	13.35	50,334	0.584	92
BI-48	692.5	13.37	65,941	0.721	92
BII-36	620.5	16.29	85,153	0.646	107
BII-48	752.5	16.33	110,499	0.784	108
BIII-36	680.5	19.25	131,145	0.709	120
BIII-48	812.5	19.29	168,367	0.846	125
BIV-36	710.5	20.73	158,644	0.740	124
BIV-48	842.5	20.78	203,088	0.878	127



**Figure 22.3** Cross section of AASHTO I-beams.

**Table 22.5** Dimensions (inches) of AASHTO I-Beams

Type	D1	D2	D3	D4	D5	D6	B1	B2	B3	B4	B5	B6
I	28.0	4.0	0.0	3.0	5.0	5.0	12.0	16.0	6.0	3.0	0.0	5.0
II	36.0	6.0	0.0	3.0	6.0	6.0	12.0	18.0	6.0	3.0	0.0	6.0
III	45.0	7.0	0.0	4.5	7.5	7.0	16.0	22.0	7.0	4.5	0.0	7.5
IV	54.0	8.0	0.0	6.0	9.0	8.0	20.0	26.0	8.0	6.0	0.0	9.0
V	63.0	5.0	3.0	4.0	10.0	8.0	42.0	28.0	8.0	4.0	13.0	10.0
VI	72.0	5.0	3.0	4.0	10.0	8.0	42.0	28.0	8.0	4.0	13.0	10.0

**Table 22.6** Properties of AASHTO I-Beams

Type	Area (in. <sup>2</sup> )	$Y_{\text{bottom}}$ (in.)	Inertia (in. <sup>4</sup> )	Weight (kip/ft)	Max. Span (ft)
I	276	12.59	22,750	0.287	48
II	369	15.83	50,980	0.384	70
III	560	20.27	125,390	0.583	100
IV	789	24.73	260,730	0.822	120
V	1,013	31.96	521,180	1.055	145
VI	1,085	36.38	733,320	1.130	167

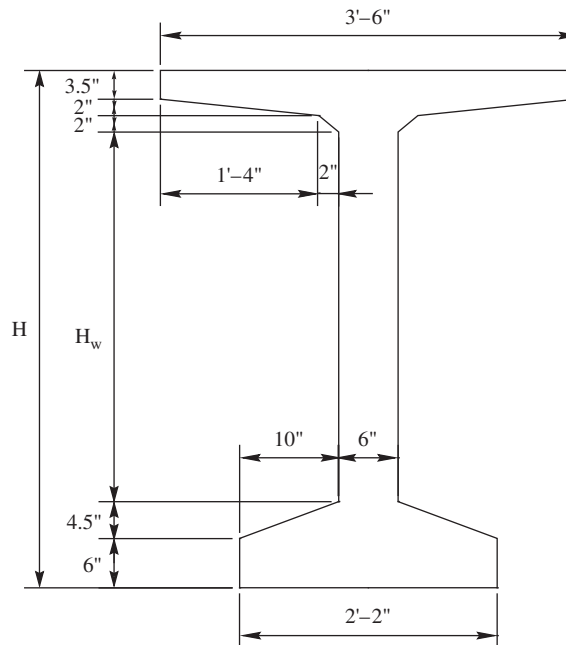


Figure 22.4 Cross section of AASHTO bulb-tees.

Table 22.7 Properties of AASHTO Bulb-Tees

Type	$H$ (in.)	$H_w$ (in.)	Area (in. <sup>2</sup> )	$Y_{\text{bottom}}$ (in.)	Inertia (in. <sup>4</sup> )	Weight (kip/ft)	Max. Span (ft)
BT-54	54	36	659	27.63	268,077	0.686	114
BT-63	63	45	713	32.12	392,638	0.743	130
BT-72	72	54	767	36.60	545,894	0.799	146

#### 22.2.4 AASHTO-PCI Bulb-Tee

Bulb-tees (Fig. 22.4) are typically used for medium-span bridges ranging up to 150 ft based on simple span, HS-25 loading, and  $f'_c = 7000$  psi. Dimensions and properties of bulb-tees are given in Table 22.7.

### 22.3 DESIGN PHILOSOPHY OF AASHTO SPECIFICATIONS

The LRFD philosophy deals with the probability of the occurrence of an event in which the loads will be greater than the resistance of a structure. The LRFD method employs limit states and design criteria to ensure that a limit state is violated only with an acceptably small probability [3]. A limit state in other words can be defined as the boundary between acceptable and unacceptable performance of structures [4].

The following limit states must be considered in designing bridges by LRFD methods [1]:

**Strength I:** Basic combination relating to the normal vehicular use of the bridge without wind.

**Strength II:** Load combination relating to the use of the bridge by owner-specified special design vehicles, evaluation permit vehicles, or both without wind.

**Strength III:** Load combination relation to the bridge exposed to wind velocity exceeding 55 mph.

**Strength IV:** Load combination relation to very high dead load to live load force effect ratios.

**Strength V:** Load combination relating to normal vehicular use of the bridge with wind velocity of 55 mph.

**Extreme Event I:** Load combination including earthquake.

**Extreme Event II:** Load combination in relation to ice load, collision vessels and vehicles, and certain hydraulic events with a reduced live load other than that which is part of the vehicular collision load.

**Service I:** Load combination relation to the normal operational use of the bridge with a 55-mph wind and all loads taken at their nominal values. Also related to deflection control in buried metal structures, tunnel liner plate, and thermoplastic pipe, to control crack width in reinforced concrete structures, and for transverse analysis relation to tension in concrete segmental girders. This load combination should also be used for the investigation of slope stability.

**Service II:** Load combination intended to control yielding of steel structures and slip of slip-critical connections due to vehicular live load.

**Service III:** Load combination for longitudinal analysis in relation to tension in prestressed concrete superstructures with the objective of crack control and to principal tension in the webs of segmental concrete girders.

**Service IV:** Load combination relating only to tension in prestressed concrete columns with the objective of crack control.

**Fatigue:** Fatigue and fracture load combination in relation to repetitive gravitational vehicular live load and dynamic responses under a single design truck having the axle spacing specified in Section 22.4.3 of this chapter.

## 22.4 LOAD FACTORS AND COMBINATIONS (AASHTO 3.4)

A general statement to assure safe design is that the resistance of the bridge systems or components supplied exceeds the demands put on them by applied loads, that is,

$$\text{Resistance} \geq \text{effect of the loads}$$

Unpredictability of the reliability on both sides of the inequality is taken into account by multiplying factors. The resistance side is multiplied by a resistance factor  $\phi$ , whose value is usually less than 1, and the load side is multiplied by a load factor  $\gamma$ , whose value is usually greater than 1. These factors are based on statistical data [2].

The basic design expression in the AASHTO LRFD that must be satisfied for all limit states is given as

$$Q = \sum \eta_i \gamma_i Q_i \leq \phi R_n \quad (22.1)$$

where

$Q$  = total force effect

$\eta_i$  = load modifier specified in Section 22.4.1



$Q_i$  = force effects from loads specified in Section 22.4.2

$\gamma_i$  = load factors specified in Tables 22.8 and 22.9

$R_n$  = nominal resistance

$\phi$  = statistically based resistance factor applied to nominal resistance

#### 22.4.1 Load Modifier (AASHTO 1.3.2.1)

The load modifier is a factor that takes into account the ductility, redundancy, and operational importance of the bridge. It is given as:

For a load for which a maximum value of  $\gamma_i$  is appropriate:

$$\eta_i = \eta_D \eta_R \eta_I \geq 0.95 \quad (22.2)$$

For a load for which a minimum value of  $\gamma_i$  is appropriate:

$$\eta_i = \frac{1}{\eta_D \eta_R \eta_I} \leq 1.0 \quad (22.3)$$

where

$\eta_i$  = load modifier

$\eta_I$  = factor relating to operational importance

$\eta_D$  = factor relating to ductility

$\eta_R$  = factor relating to redundancy

**22.4.1.1 Ductility (AASHTO 1.3.3).** The structural system of a bridge shall be proportioned and detailed to ensure the development of significant and visible inelastic deformations at the strength and extreme event limit states before failure.

The values to be used for the strength limit state are:

$\eta_D \geq 1.05$  for nonductile components and connections

= 1.00 for conventional designs and details complying with AASHTO specifications

$\geq 0.95$  for components and connections for which additional ductility – enhancing

measures have been specified beyond those required by the specifications

For all other limit states:

$$\eta_D = 1.00$$

**22.4.1.2 Redundancy (AASHTO 1.3.4).** Redundancy in a bridge system increases its margin of safety, and it is reflected in the strength limit state by redundancy factors given as

$\eta_R \geq 1.05$  for nonredundant members

= 1.00 for conventional level of redundancy

$\geq 0.95$  for exceptional levels of redundancy

For all other limit states:

$$\eta_R = 1.00$$

**22.4.1.3 Operational Importance (AASHTO 1.3.5).** Operational importance shall apply to the strength and extreme event limit states only. Bridges can be considered of operational importance if they are on the shortest path between residential areas and a hospital or school or provide access for

police, fire, and rescue vehicles to homes, businesses, and industrial plants [2]. Such classification should be based on social/survival and/or security/defense requirements [1].

For the strength limit state:

$$\begin{aligned}\eta_t &\geq 1.05 \text{ for important bridges} \\ &= 1.00 \text{ for typical bridges} \\ &\geq 0.95 \text{ for relatively less important bridges}\end{aligned}$$

For all other limit states:

$$\eta_t = 1.00$$

### 22.4.2 Load and Load Designation (AASHTO 3.3.2)

In AASHTO LRFD bridge design specifications, loads are classified as permanent and transient. The following permanent and transient loads and forces are used in Tables 22.8 and 22.9 for the load combinations and corresponding factors:

#### Permanent Loads

DD	Downdrag
DC	Dead load of structural components and nonstructural attachment
DW	Dead load of wearing surfaces and utilities
EH	Horizontal earth pressure load
EL	Accumulated locked-in force effects resulting from the construction process, including the secondary forces from posttensioning
ES	Earth surcharge load
EV	Vertical pressure from dead load of earth fill

#### Transient Loads

BR	Vehicular braking force
CE	Vehicular centrifugal force
CR	Creep
CT	Vehicular collision force
CV	Vessel collision force
EQ	Earthquake
FR	Friction
IC	Ice load
IM	Vehicular dynamic load allowance
LL	Vehicular live load
LS	Live-load surcharge
PL	Pedestrian live load
SE	Settlement
SH	Shrinkage
TG	Temperature gradient
TU	Uniform temperature
WA	Water load and stream pressure
WL	Wind on live load
WS	Wind on structure

### 22.4.3 Load Combinations and Load Factors (AASHTO 3.4.1.1)

The load factors for various load combinations and permanent loads are given by AASHTO and reproduced in Table 22.8 and Table 22.9, respectively. Note that both a maximum and a

**Table 22.8** Load Combinations and Load Factors

Load Combination Limit State	DC	LL						TU	Use One of These at a Time					
	DD	IM	WA	WS	WL	FR	CR	TG	SE	EQ	IC	CT	CV	
	DW	CE	ES	PL	EL	LS	SH							
Strength I (unless noted)	$\gamma_P$	1.75	1.00	—	—	1.00	0.50/1.20	$\gamma_{TG}$	$\gamma_{SE}$	—	—	—	—	
Strength II	$\gamma_P$	1.35	1.00	—	—	1.00	0.50/1.20	$\gamma_{TG}$	$\gamma_{SE}$	—	—	—	—	
Strength III	$\gamma_P$	—	1.00	1.40	—	1.00	0.50/1.20	$\gamma_{TG}$	$\gamma_{SE}$	—	—	—	—	
Strength IV	$\gamma_P$	—	1.00	—	—	1.00	0.50/1.20	—	—	—	—	—	—	
Strength V	$\gamma_P$	1.35	1.00	0.40	1.00	1.00	0.50/1.20	$\gamma_{TG}$	$\gamma_{SE}$	—	—	—	—	
Extreme Event I	$\gamma_P$	$\gamma_{EQ}$	1.00	—	—	1.00	—	—	—	1.00	—	—	—	
Extreme Event II	$\gamma_P$	0.50	1.00	—	—	1.00	—	—	—	—	1.00	1.00	1.00	
Service I	1.00	1.00	1.00	0.30	1.00	1.00	0.50/1.20	$\gamma_{TG}$	$\gamma_{SE}$	—	—	—	—	
Service II	1.00	1.30	1.00	—	—	1.00	0.50/1.20	—	—	—	—	—	—	
Service III	1.00	0.80	1.00	—	—	1.00	0.50/1.20	$\gamma_{TG}$	$\gamma_{SE}$	—	—	—	—	
Service IV	1.00	—	1.00	0.70	—	1.00	0.50/1.20	—	1.0	—	—	—	—	
Fatigue—LL, IM, and CE Only	—	0.75	—	—	—	—	—	—	—	—	—	—	—	

Source: AASHTO LRFD Bridge Design Specifications, 2014. Used by permission.

**Table 22.9** Load Factors for Permanent Loads,  $\gamma_p$ 

Type of Load, Foundation Type, and Method Used to Calculate Downdrag	Load Factor	
	Maximum	Minimum
DC: Component and attachments	1.25	0.90
DC: Strength IV only	1.50	0.90
DD: Downdrag		
Piles, $\alpha$ Tomlinson method	1.40	0.25
Piles, $\lambda$ Method	1.05	0.30
Drilled shafts, O'Neill and Rees (1999)	1.25	0.35
DW: Wearing surfaces and utilities	1.50	0.65
EH: Horizontal earth pressure		
Active	1.50	0.90
At rest	1.35	0.90
AEP for anchored walls	1.35	N/A
EL: Locked-in erection stresses	1.00	1.00
EV: Vertical earth pressure		
Overall stability	1.00	N/A
Retaining walls and abutments	1.35	1.00
Rigid buried structure	1.30	0.90
Rigid frames	1.35	0.90
Flexible buried structures other than metal box culverts	1.95	0.90
Flexible metal culverts	1.50	0.90
ES: Earth surcharge	1.50	0.75

Source: AASHTO LRFD Bridge Design Specifications, 2014. Used by permission.

minimum factor for the permanent loads are specified in Table 22.9. The minimum factors are to be used in the strength limit states to produce maximum effects of live load. In other words, when the effect of live load is opposite to that of permanent load, the minimum combinations are to be used.

## 22.5 GRAVITY LOADS

Gravity loads include permanent and live loads that are caused by the self-weight of the bridge and the weight of objects on the bridge. Such loads are applied in a downward direction (toward the center of the earth).

### 22.5.1 Permanent Loads (AASHTO 3.5)

Permanent loads include dead loads and earth loads that remain on the bridge for the entire service life. Such loads include DC, DW, EV, EH, ES, and DD specified in Section 22.4.2.

### 22.5.2 Live Loads (AASHTO 3.6)

The scope is limited to gravity live loads, which include vehicular live load (LL) and pedestrian live load (PL).

**22.5.2.1 Vehicular Live Load (AASHTO 3.6.1.1).** A typical bridge is designed for several longitudinal traffic lanes of equal width that are defined as traffic lane and design lane. The traffic lane is the amount of traffic that the traffic engineer plans to route across the bridge whose width is associated with a traffic lane of, typically, 10 to 14 ft. The design lane is the number of lane designation that the bridge engineer uses for live-load placement to produce maximum load effects.

Generally, the number of design lanes should be determined by taking the integer part of the ratio  $w/12.0$ , where  $w$  is the clear roadway width in feet between curbs and/or barriers. Engineering judgment shall be used to ensure that the number of design lanes is not less than the number of traffic lanes. In case where the traffic lanes are less than 12.0 ft wide, the number of design lanes shall be equal to the number of traffic lanes, and the width of the design lane shall be taken as the width of the traffic lane. Possible future changes in the physical or functional clear roadway width of the bridge should be considered. Roadway widths from 20.0 to 24.0 ft shall have two design lanes, each equal to one-half the roadway width.

**22.5.2.2 Multiple Presence of Live Load (AASHTO 3.6.1.2).** The extreme live-load effect shall be determined by considering each possible combination of number of loaded lanes multiplied by a corresponding multiple presence factor to account for the probability of simultaneous lane occupation by full HL-93 design live load. Multiple presence factors have been included in the equations for distribution factors and, therefore, shall not be applied in conjunction with load distribution factors except where a lever rule is used. The multiple presence factors are given in Table 22.10.

**22.5.2.3 Design Vehicular Live Load (AASHTO 3.6.1.2).** Although the automobile is the most common vehicular live load on most bridges, trucks cause the critical load effects. Therefore, AASHTO design live loads attempt to model the truck traffic that may occur independent of or combined with other truck loads.

**Table 22.10** Multiple Presence Factors  $m$ 

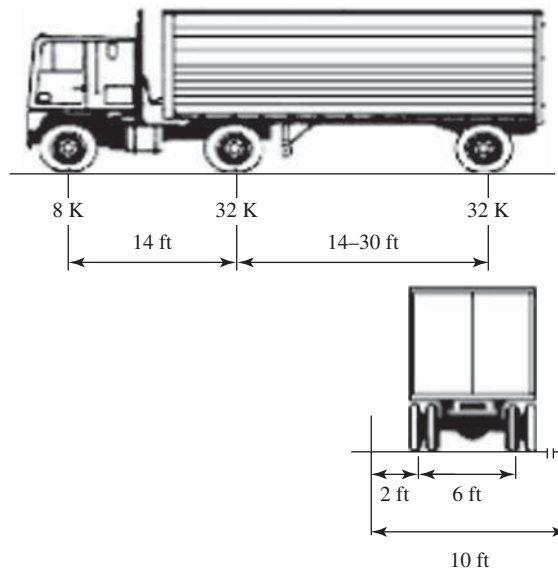
Number of Loaded Lanes	Multiple Presence Factors, $m$
1	1.20
2	1.00
3	0.85
>3	0.65

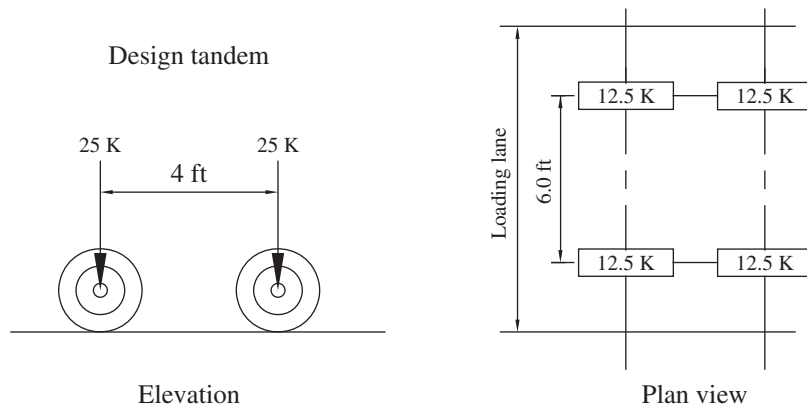
Vehicular live loading that AASHTO employs is HL-93 (highway loading developed/adopted in 1993), which was previously called HS20-44 (highway semitrailer with weight of 20 tons adopted in 1944). This model consists of three types of different live loads, namely, a design truck, a tandem, and a design lane load.

**22.5.2.3.1 Design Truck (AASHTO 3.6.1.2.2).** The weights and spacing of axles and wheels for the design truck are shown in Fig. 22.5. The spacing between the two 32.0-K axles shall be varied between 14.0 and 30.0 ft to produce extreme force effects. A dynamic load allowance, IM, shall be considered.

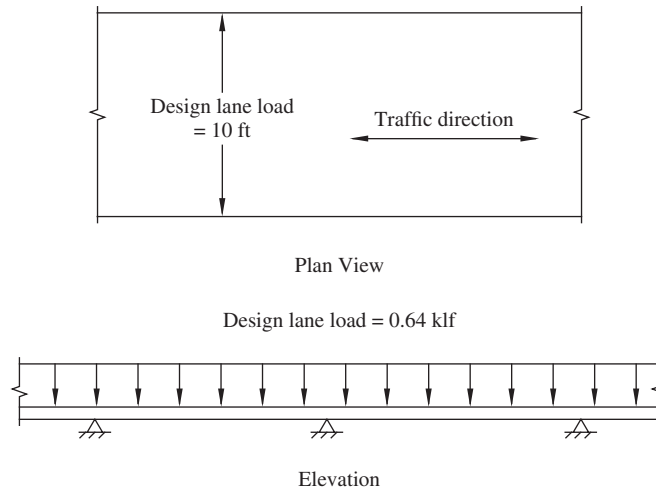
**22.5.2.3.2 Design Tandem (AASHTO 3.6.1.2.3).** The design tandem shall consist of a pair of 25.0-K axles spaced 4.0 ft apart. The transverse spacing of wheels shall be taken as 6.0 ft, shown in Fig. 22.6. A dynamic load allowance, IM, shall be considered.

**22.5.2.3.3 Design Lane Load (AASHTO 3.6.1.2.4).** The design lane load shall consist of a load of 640 lb per linear foot (or 0.64 klf) of design lane uniformly distributed in the longitudinal direction. Transversely, the design lane load shall be assumed to be uniformly distributed over a 10.0-ft width (Fig. 22.7). No dynamic load allowance shall be applied.

**Figure 22.5** Characteristics of the design truck (HL-93) specified by AASHTO.



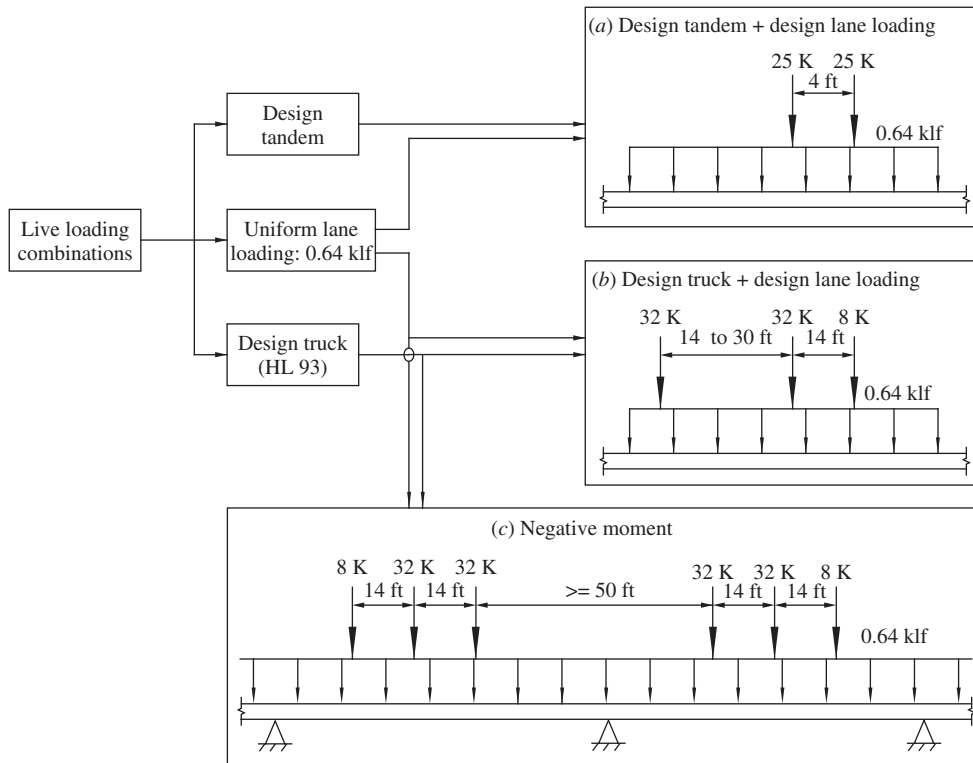
**Figure 22.6** Characteristics of the design tandem specified by AASHTO.



**Figure 22.7** Characteristics of design lane load specified by AASHTO.

**22.5.2.3.4 Live-Load Combinations for Design (AASTO 3.6.1.3).** AASHTO specifies the three basic types of loadings described above are to be combined in the following three combinations to produce maximum load effects:

1. The effect of the design tandem combined with the effect of design lane load.
2. The effect of one design truck with the various axle spacing combined with the effect of design lane load.
3. For negative moment between points of contraflexure under a uniform load on all spans, and reaction at interior piers only, 90% of the effect of two design trucks spaced a minimum of 50.0 ft between the load axle of one truck and the rear axle of the other truck, combined with 90% of the effect of the design lane load. The distance between the 32.0-K axles of each truck shall be taken as 14.0 ft.



**Figure 22.8** The AASHTO HL-93 design loadings and load combinations.

The loads are placed in such a way as to generate maximum live-load effects in the combinations described above, among which the critical condition governs the design. These combinations are summarized in Fig. 22.8.

**22.5.2.3.5 Fatigue Load (AASHTO 3.6.1.4).** One truck design with the variable axle spacing set at 30 ft shall be considered in the fatigue and fracture limit state to take into account the cyclic live loading. The dynamic load allowance must be included.

Since the fatigue and fracture limit state is defined in terms of accumulated stress-range cycles, load should be specified along with the frequency of load occurrence, namely, average daily truck traffic (ADTT).

**22.5.2.4 Pedestrian Loads (AASHTO 3.6.1.6).** A pedestrian load of 75 lb per liner foot (or 0.075 ksf) shall be applied to all sidewalks wider than 2.0 ft concurrently with the vehicular load.

If bridges are designed for only pedestrian and/or bicycle traffic, then 85 lb per liner foot (or 0.085 ksf) live load shall be applied. Pedestrian and/or bicycle bridges shall be designed for maintenance truck and/or other incidental vehicles that are intended to be used.

**22.5.2.5 Dynamic Load Allowance: IM (AASHTO 3.6.2).** Roadway roughness and irregularity induces the vehicle suspension systems to oscillate compression and extension. Axle force

**Table 22.11** Dynamic Load Allowance, IM

Component	IM (%)
Deck joint—all limit states	75
All other components	
• Fatigue and fracture limit state	15
• All other limit state	33

can be greater or less than the static weight when the acceleration is upward or downward, respectively [2].

Dynamic effects due to moving vehicles may be attributed to two sources:

1. Dynamic response of the wheel assembly is called the Hammering effect, and it may occur due to riding surface discontinuities, such as deck joints, cracks, potholes, and delimitations.
2. Dynamic response of the bridge as a whole to passing vehicles, which may be due to long undulations in the roadway pavement, such as those caused by settlement of fill, or to resonant excitation as a result of similar frequencies of vibration between bridge and vehicle.

The factor to be applied to the static load shall be taken as  $1 + IM/100$ , and factors are given in Table 22.11.

### 22.5.3 Static Analysis (AASHTO 4.6)

A bridge deck is the medium through which all bridge loads are transferred to other subsequent components. A concentrated load placed on a bridge deck is distributed over an area larger than the actual contact area. Thus, a larger portion of the deck will resist the load [3].

Bridge decks can be classified as follows based on applicability of analytical method:

1. Decks (AASHTO 4.6.2.1)
2. Beam–slab bridge (AASHTO 4.6.2.2)

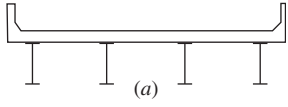
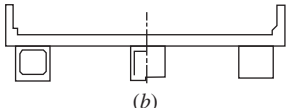
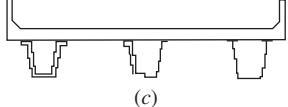
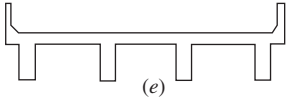
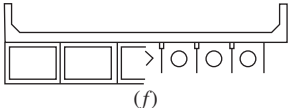
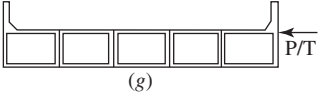
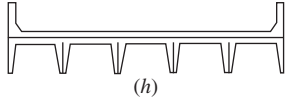
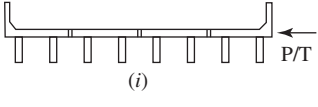
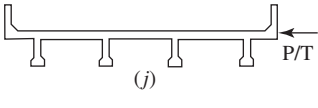
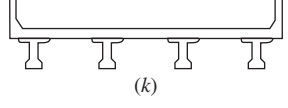
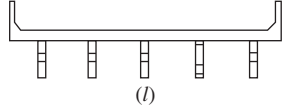
Several analysis methods are available to determine load distribution in bridge decks among which are classical methods, computer methods, and approximate methods. In this chapter, a beam–slab bridge with an approximate method will be described. It is summarized in following steps:

1. Moments and shears at any section are first determined assuming a fully loaded lane.
2. These loads are multiplied by the approximate distribution factor to determine the moment and shear in a particular beam, girder, or strip of slab.

**22.5.3.1 Load Distribution Factors in Beam-Slab Bridges (AASHTO 4.6.2.2).** Table 22.12 shows common deck superstructure for which equations for the beam distribution factors have been developed by AASHTO. Corresponding distribution factors for moments in interior beams are reproduced in Table 22.13, and readers are encouraged to refer to AASHTO Table 4.6.2.2.d-1, Table 4.6.1.1.3.a-1, and Table 4.6.2.2.3b-1 for distribution factors for moment in exterior beams, for shear in interior beams, and for shear in exterior beams, respectively.



**Table 22.12** Common Deck Superstructures

Supporting Components	Type of Deck	Typical Cross Section
Steel beam	Cast-in-place concrete slab, precast concrete slab, steel grid, glued/spiked panels, stressed wood	
Closed steel or precast concrete boxes	Cast-in-place concrete slab	
Open steel or precast concrete boxes	Cast-in-place concrete slab, precast concrete deck slab	
Cast-in-place concrete multicell box	Monolithic concrete	
Cast-in-place concrete tee beam	Monolithic concrete	
Precast solid, voided, or cellular concrete boxes with shear keys	Cast-in-place concrete overlay	
Precast solid, voided, or cellular concrete box with shear keys and with or without transverse posttensioning	Integral concrete	
Precast concrete channel sections with shear keys	Cast-in-place concrete overlay	
Precast concrete double tee section with shear keys and with or without transverse posttensioning	Integral concrete	
Precast concrete tee section with shear keys and with or without transverse posttensioning	Integral concrete	
Precast concrete I or bulb-tee sections	Cast-in-place concrete, precast concrete	
Wood beams	Cast-in-place concrete or plank, glued/spiked panels, or stressed wood	

Source: AASHTO LRFD Bridge Design Specifications, 2014. Used by permission.

**Table 22.13** Distribution of Live Load per Lane for Moment in Interior Beams

Type of Superstructure	Applicable Cross Section from Table 22.11	Distribution Factors	Range of Applicability
Wood deck on wood or steel beams	a, l	See 22.12	
Concrete deck on wood beams	l	One design lane loaded: $S/12.0$ Two or more design lanes loaded: $S/10.0$	$S \leq 6.0$
Concrete deck, filled grid, partially filled grid, or unfilled grid deck composite with reinforced concrete slab on steel or concrete beams; concrete T-beams, T- and double T-sections	a, e, k, and also i, j if sufficiently connected to act as unit	One design lane loaded: $0.06 + \left(\frac{S}{14}\right)^{0.4} \left(\frac{S}{L}\right)^{0.3} \left(\frac{K_g}{12.0Lt_s^3}\right)^{0.1}$ Two or more design lanes loaded: $0.075 + \left(\frac{S}{9.5}\right)^{0.6} \left(\frac{S}{L}\right)^{0.2} \left(\frac{K_g}{12.0Lt_s^3}\right)^{0.1}$ Use lesser of the values obtained from the equation above with $N_b = 3$ or the lever rule	$3.5 \leq S \leq 16.0$ $4.5 \leq t_s \leq 12.0$ $20 \leq L \leq 240$ $N_b \geq 4$ $10,000 \leq K_g \leq 7,000,000$ $N_b = 3$
Cast-in-place concrete multicell box	d	One design lane loaded: $\left(1.75 + \frac{S}{3.6}\right) \left(\frac{1}{L}\right)^{0.35} \left(\frac{1}{N_c}\right)^{0.45}$ Two or more design lanes loaded: $0.075 + \left(\frac{S}{9.5}\right)^{0.6} \left(\frac{S}{L}\right)^{0.2} \left(\frac{K_g}{12.0Lt_s^3}\right)^{0.1}$	$7.0 \leq S \leq 13.0$ $60 \leq L \leq 240$ $N_c \geq 3$ If $N_c > 8$ use $N_c = 8$
Concrete deck on concrete spread box beams	b, c	One design lane loaded: $\left(\frac{S}{3.0}\right)^{0.35} \left(\frac{Sd}{12.0L^2}\right)^{0.25}$ Two or more design lanes loaded: $\left(\frac{S}{9.635}\right)^{0.6} \left(\frac{Sd}{12.0L^2}\right)^{0.125}$ Use lever rule	$6.0 \leq S \leq 18.0$ $20 \leq L \leq 140$ $18 \leq d \leq 65$ $N_b \geq 3$ $S > 18.0$
Concrete beams used in multibeam decks	f	One design lane loaded: $k \left(\frac{b}{33.3L}\right)^{0.5} \left(\frac{I}{12.0L^2}\right)^{0.125}$ where $k = 2.5(N_b)^{-0.2} \geq 1.5$ Two or more design lanes loaded: $k \left(\frac{bS}{305}\right)^{0.6} \left(\frac{b}{12.0L}\right)^{0.2} \left(\frac{I}{J}\right)^{0.06}$	$35 \leq b \leq 60$ $20 \leq L \leq 120$ $5 \leq N_b \leq 20$
	g if sufficiently connected to act as a unit		

(continued)

Table 22.13 (Continued)

Type of Superstructure	Applicable Cross Section from Table 22.11	Distribution Factors	Range of Applicability
	h	Regardless of number of loaded lanes: S/D	$N_L \leq 6$
	g, i, and j if connected only enough to prevent relative vertical displacement at the interface	where $C = K(W/L) \leq K$ $D = 11.5 - N_L + 1.4N_L(1 - 0.2C)^2$ When $C \leq 5$ , $D = 11.5 - N_L$ when $C > 5$ $K = \sqrt{\frac{(1 + \mu)I}{J}}$	
		For preliminary design, the following values of $K$ may be used Beam type $K$ Nonvoided rectangular beams: 0.7 Rectangular beams with circular voids: 0.8 Box section beams: 1.0 Channel beams: 2.2 T-beam: 2.0 Double T-beam: 2.0	
Open steel grid deck on steel beams	a	One design lane loaded: (S/7.5) If $t_g < 4.0$ (S/10.0) If $t_g \geq 4.0$ Two or more design lanes loaded: (S/8.0) If $t_g < 4.0$ (S/10.0) If $t_g \geq 4.0$	$S \leq 6.0$  $S \leq 6.0$
Concrete Deck on Multiple steel Box Girders	b,c	Regardless of number of loaded lanes: $0.05 + 0.85 \frac{N_L}{N_b} + \frac{0.425}{N_L}$	$0.5 \leq \frac{N_L}{N_b} \leq 1.5$

Source: AASHTO LRFD Bridge Design Specifications, 2014. Used by permission.

**22.5.3.2 Live-Load Moments and Shears in Simply Supported Spans.** The maximum bending due to the uniform lane loading of 0.64 kip/ft occurs at midspan and may be computed from the following expressions:

$$\text{Maximum } M_{LL} = \frac{0.64(x)(L-x)}{2} \text{ kip} \cdot \text{ft} \quad (22.4)$$

where

$x$  = distance from left support, ft

$L$  = beam span, ft

Bending moments due to the design truck and the design tandem are to be computed using the influence line. Equations of moments and shears due to live-load trucks for simple span bridges are available in many references, and readers are encouraged to refer to References 2, 3, 4, and 5 for more details.

The maximum bending moments may be computed from the following expressions [4]:

$$\text{Maximum } M_{LL} = P \left( \frac{9}{8}L + \frac{24.5}{L} - 17.50 \right) \text{ kip} - \text{ft} \quad (22.5)$$

where

$P$  = one axle load = 16.0 kips

$L$  = beam span, ft

The maximum bending moments due to the design tandem may be computed from the following expressions [4]:

$$\text{Maximum } M_{LL} = 50 \left( \frac{L}{4} - 1 - \frac{3}{L} \right) \text{ kip} - \text{ft} \quad (22.6)$$

where  $L$  is the beam span in feet.

**22.5.3.3 Wind Loads (AASHTO 4.6.2.7).** Wind load is dynamic load. However, it is generally approximated as a uniformly distributed static load on the exposed area of a bridge. This area is taken as the combined surfaces of both the superstructure and the substructure including, floor systems and railings as seen in the elevation  $90^\circ$  to the longitudinal axis of the structure. Design wind load is based on an assumed “base wind velocity” of 100 mph [9].

**22.5.3.4 Seismic Lateral Load Distribution (AASHTO 4.6.2.8).** For most prestressed structures, where the superstructure is not integral with the substructure, seismic forces do not affect beam design [9]. Details of analysis methods are beyond the scope of this chapter.

**22.5.3.5 Effective Flange Width (AASHTO 4.6.2.6).** For interior beams, the effective flange width may be taken as the least of:

- One-quarter of the effective span length.
- 12.0 times the average depth of the slab, plus the greater of web thickness or one-half the width of the top flange of the girder.
- The average spacing of adjacent beams.

For exterior beams, the effective flange width may be taken as one-half the effective width of the adjacent interior beam, plus the least of:

- One-eighth of the effective span length.
- 6.0 times the average depth of the slab, plus the greater of one-half the web thickness or one-quarter of the width of the top flange of the basic girder.
- The width of the overhang.

## 22.6 DESIGN FOR FLEXURAL AND AXIAL FORCE EFFECTS (AASHTO 5.7)

### 22.6.1 Flexural Members (AASHTO 5.7.3)

For rectangular or flanged section subjected to flexure about one axis where the approximate rectangular stress distribution is used and for which  $f_{pe}$  is not less than  $0.5 f_{pu}$ , the average stress in prestressing steel,  $f_{ps}$ , may be taken as:

$$f_{ps} = f_{pu} \left( 1 - k \frac{c}{d_p} \right) \quad (22.7)$$

where

$$k = 2 \left( 1.04 - \frac{f_{py}}{f_{pu}} \right) \quad (22.8)$$

Values of  $f_{py}/f_{pu}$  and  $k$  are determined in the Table 22.14.

For T-section behavior:

$$c = \frac{A_{ps}f_{pu} + A_s f_s - A'_s f'_s - 0.85(b - b_w)h_f}{0.85f'_c \beta b_w + k A_{ps}(f_{pu}/d_p)} \quad (22.9)$$

For rectangular section behavior:

$$c = \frac{A_{ps}f_{pu} + A_s f_s - A'_s f'_s}{0.85f'_c \beta b + k A_{ps}(f_{pu}/d_p)} \quad (22.10)$$

where

$A_{ps}$  = area of prestressing steel (in.<sup>2</sup>)

$f_{pu}$  = specified tensile strength of prestressing steel (ksi)

$f_{py}$  = yield strength of prestressing steel (ksi)

$A_s$  = area of mild steel tension reinforcement (in.<sup>2</sup>)

$A'_s$  = area of compression reinforcement (in.<sup>2</sup>)

$f_s$  = stress in mild steel tension reinforcement at nominal flexural resistance (ksi)

$f'_s$  = stress in mild steel compression reinforcement at nominal flexural resistance (ksi)

$b$  = width of compression flange (in.)

$b_w$  = width of web (in.)

$h_f$  = depth of compression flange (in.)

$d_p$  = distance from extreme compression fiber to centroid of prestressing tendons (in.)

$c$  = distance between neutral axis and compressive fiber (in.)

$\beta_1$  = stress block factor

### 22.6.2 Flexural Resistance (AASHTO 5.7.3.2)

The factored resistance  $M_r$  shall be taken as

$$M_r = \phi M_n \quad (22.11)$$

**Table 22.14** Values of  $f_{py}/f_{pu}$  and  $k$

Type of Tendon	$f_{py} / f_{pu}$	Value of $k$
Low relaxation strand	0.9	0.28
Stress-relieved strand and type 1 high-strength bar	0.85	0.38
Type 2 high-strength bar	0.80	0.48

where

$M_n$  = nominal resistance (kip · in)

$\phi$  = resistance factor as specified in AASHTO 5.5.4.2

### 22.6.3 Limits for Reinforcement (AASHTO 5.7.3.3)

**22.6.3.1 Maximum Reinforcement (AASHTO 5.7.3.3.1).** This provision was been deleted from the AASHTO specification in 2005. The current provisions of LRFD eliminate this limit and unify the design of prestressed and nonprestressed tension- and compression-controlled members. Below a net tensile strain in the extreme tension steel of 0.005, as the tension reinforcement quantity increases, the factored resistance of prestressed and nonprestressed sections is reduced in accordance with AASHTO 5.5.4.2.1. This reduction compensates for decreasing ductility with increasing overstrength. Only the addition of compression reinforcement can result in an increase in the factored flexural resistance of the section.

**22.6.3.2 Minimum Reinforcement (AASHTO 5.7.3.3.2).** The amount of prestressed and nonprestressed tensile reinforcement shall be adequate to develop a factored flexural resistance,  $M_r$ , at least equal to the lesser of:

- 1.2 times the cracking moment,  $M_{cr}$ , determined on the basis of elastic stress distribution and the modulus of rupture,  $f_r$ , of the concrete, where  $M_{cr}$  may be taken as

$$M_{cr} = S_c(f_r + f_{cpe}) - M_{dnc} \left( \frac{S_c}{S_{nc}} - 1 \right) \geq S_c f_r \quad (22.12)$$

where

$f_{cpe}$  = compressive stress in concrete due to effective prestress forces only at extreme fiber of section where tensile stress is caused by externally applied loads (ksi)

$M_{dnc}$  = total unfactored dead load moment acting on the monolithic or noncomposite section (kip·ft)

$S_c$  = section modulus for the extreme fiber of composite section where tensile stress is caused by externally applied loads (in.<sup>3</sup>)

$S_{nc}$  = section modulus for the extreme fiber of monolithic or noncomposite section where tensile stress is caused by externally applied loads (in.<sup>3</sup>)

- 1.33 times the factored moment required by the applicable strength load combinations specified in Table 22.8.

## 22.7 DESIGN FOR SHEAR (AASHTO 5.8)

The AASHTO specifications direct a designer to use the sectional model to design for shear and torsion when it is reasonable to assume that plane sections remain plane after loading. The resistance of members in shear or in shear combined with torsion may be determined by satisfying the conditions of force equilibriums and strain compatibility by utilizing experimentally verified stress–strain curves for reinforcement and for diagonally cracked concrete.

The sectional model is appropriate for the design of typical bridge girders, slab, and other regions of components where the assumptions of traditional engineering beam theory are valid.

Components in which the distance from the point of zero shear to the face of the support is less than  $2d$ , or components in which a load causing more than  $\frac{1}{2}$  of the shear at a support is closer than  $2d$  from the face of the support, may be considered to be deep components and shall be designed for shear and torsion using the strut-and-tie model (AASHTO 5.8.1.1).

Where the plane sections assumption of flexural theory is not valid, regions of members shall be designed for shear and torsion using the strut-and-tie model. Some of the examples are regions adjacent to abrupt changes in cross section, openings, dapped ends, deep beams, and corbels (AASHTO 5.8.1.2).

Interfaces between elements shall be designed for shear transfer (AASHTO 5.8.1.3).

### 22.7.1 Shear Design Procedures (AASHTO 5.8.1)

There are two recommended approach by AASHTO LRFD 2014 to design for shear: The Strut-and-Tie Model, which was explained in Chapter 8, and the Modified Compression Field Theory (MCFT).

AASHTO LRFD 2014, also, recommends a simplified approach based on the Modified compression field theory. The MCFT and the simplified MCFT approaches are discussed in Sections 22.7.2 through 22.7.10.

### 22.7.2 Approach 1: MCFT

Modified Compression Field Theory, unlike Strut-and-Tie Model, which is discussed at member level, presents its equation at sectional level. This model was developed by Collins and Mitchell [11]. In general, the following equation must be satisfied at each section:

$$V_r = \phi V_n \geq V_u \quad (22.13)$$

where

$V_r$  = design shear resistance

$V_n$  = nominal shear resistance

$V_u$  = factored shear force

$\phi$  = resistance factor for shear: 0.9 for normal-weight concrete, 0.7 for lightweight concrete

The shear design procedure using the modified compression field theory consists of the following steps:

1. Determine the factored shear  $V_u$  and moment  $M_u$  envelopes due to the strength limit states at the point of interest.
2. Compute the nominal shear stress  $v_u$  and obtain the shear stress ratio  $v_u/f'_c$ .
3. Estimate a value of  $\theta$  and calculate the longitudinal strain  $\epsilon_x$ .
4. Use the calculated values of  $v_u/f'_c$  and  $\epsilon_x$  to determine  $\theta$  from Table 22.15 and compare with the estimated value in step 3. If different, recalculate and iterate step 4 until the estimated value of  $\theta$  agrees with the value from Table 22.15. Select corresponding value of  $\beta$ .
5. Calculate the required web reinforcement strength  $V_s$  and the required spacing of stirrups.

### 22.7.3 Shear Stress on Concrete (AASHTO 5.8.2.9)

The shear stress on the concrete shall be determined as

$$v_u = \frac{|V_u - \phi V_p|}{\phi b_v d_v} \quad (22.14)$$

**Table 22.15** Values of  $\theta$  and  $\beta$  for Sections with Transverse Reinforcement

$\frac{V_u}{f'_c}$	$\epsilon_x \times 1000$								
	$\leq -0.20$	$\leq -0.10$	$\leq -0.05$	$\leq 0$	$\leq 0.125$	$\leq 0.25$	$\leq 0.50$	$\leq 0.75$	$\leq 1.00$
$\leq 0.075$	22.3	20.4	21.0	21.8	24.3	26.6	30.5	33.7	36.4
	6.32	4.75	4.10	3.75	3.24	2.94	2.59	2.38	2.23
$\leq 0.100$	18.1	20.4	21.4	22.5	24.9	27.1	30.8	34.0	36.7
	3.79	3.38	3.24	3.14	2.91	2.75	2.50	2.32	2.18
$\leq 0.125$	19.9	21.9	22.8	23.7	25.9	27.9	31.4	344.4	37.0
	3.18	2.99	2.94	2.87	2.74	2.62	2.42	2.26	2.13
$\leq 0.150$	21.6	23.3	24.2	25.0	26.9	28.8	32.1	34.9	37.3
	2.88	2.79	2.78	2.72	2.60	2.52	2.36	2.21	2.08
$\leq 0.175$	23.2	24.7	25.5	26.2	28.0	29.7	32.7	35.2	36.8
	2.73	2.66	2.65	2.60	2.52	2.44	2.28	2.14	1.96
$\leq 0.200$	24.7	26.1	26.7	27.4	29.0	30.6	32.8	34.5	36.1
	2.63	2.59	2.52	2.51	2.43	2.37	2.14	1.94	1.79
$\leq 0.225$	26.1	27.3	27.9	28.5	30.0	30.8	32.3	34.0	35.7
	2.53	2.45	2.42	2.40	2.34	2.14	1.86	1.73	1.64
$\leq 0.250$	27.5	28.6	29.1	29.7	30.6	31.3	32.8	34.3	35.8
	2.39	2.39	2.33	2.33	2.12	1.93	1.70	1.58	1.50

Source: AASHTO LRFD Bridge Design Specifications, 2014. Used by permission.

where

$b_v$  = effective web width taken as minimum web width, measured parallel to neutral axis, between resultants of tensile and compressive forces due to flexure, or for circular sections, diameter of section, modified for presence of ducts where applicable (in.).

$d_v$  = effective shear depth taken as distance, measured perpendicular to neutral axis, between resultants of tensile and compressive forces due to flexure; it need not be taken to be less than the greater of  $0.9d_e$  or  $0.72h$  (in.).

#### 22.7.4 Longitudinal Strain (AASHTO 5.8.3.4.2)

For sections containing at least the minimum amount of transverse reinforcement required by the code, the values of  $\beta$  and  $\theta$  shall be as specified in Table 22.15. In using this table,  $\epsilon_x$  shall be taken as the calculated longitudinal strain at the middepth of the member when the section is subjected to  $N_u$ ,  $M_u$ , and  $V_u$  as in Fig. 22.9. Longitudinal strain,  $\epsilon_x$  shall be determined as

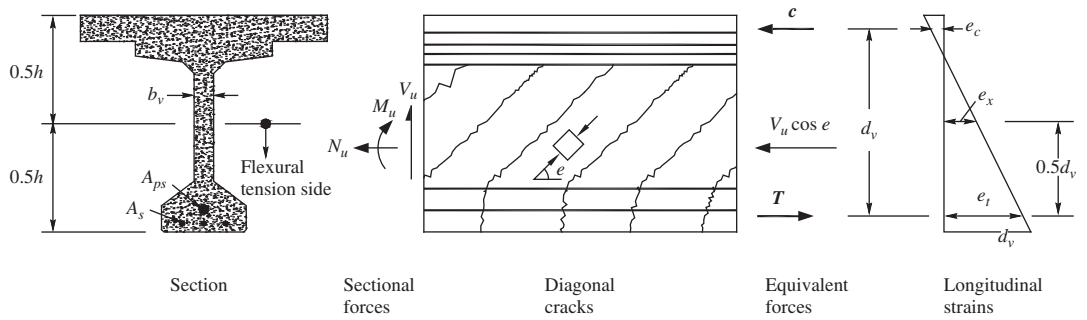
$$\epsilon_x = \frac{(|M_u|/d_v)0.5N_u + 0.5|V_u - V_p| \cot \theta - A_{ps}f_{po}}{2(E_sA_s + E_pA_{ps})} \quad (22.15)$$

The initial value of  $\epsilon_x$  should not be taken greater than 0.001.

For sections containing less than the minimum amount of transverse reinforcement required by the code, the values of  $\beta$  and  $\theta$  shall be as specified in Table 22.16. In using this table,  $\epsilon_x$  shall be taken as the largest calculated longitudinal strain that occurs within the web of the member when the section is subjected to  $N_u$ ,  $M_u$ , and  $V_u$  as in Fig. 22.10:

$$\epsilon_x = \frac{(|M_u|/d_v) 0.5N_u + 0.5|V_u - V_p| \cot \theta - A_{ps}f_{po}}{E_sA_s + E_pA_{ps}} \quad (22.16)$$



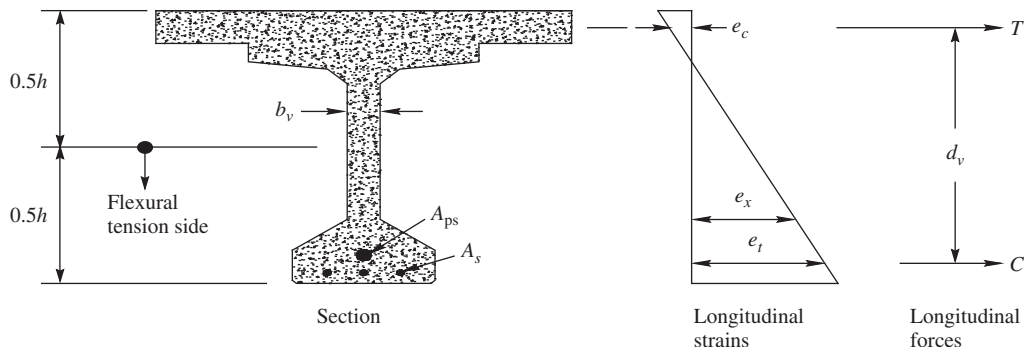


**Figure 22.9** Illustration of shear parameters for section containing at least the minimum amount of transverse reinforcement,  $V_p = 0$ . *AASHTO LRFD Bridge Design Specifications*, 2014. Used by permission

**Table 22.16** Values of  $\theta$  and  $\beta$  for Sections with Less Than Minimum Transverse Reinforcement

$s_{xe}$ (in.)	$\epsilon_x \times 1000$										
	$\leq -0.20$	$\leq -0.10$	$\leq -0.05$	$\leq 0$	$\leq 0.125$	$\leq 0.25$	$\leq 0.50$	$\leq 0.75$	$\leq 1.00$	$\leq 1.50$	$\leq 2.00$
$\leq 5$	25.4	25.5	25.9	26.4	27.7	28.9	30.9	32.4	33.7	35.6	37.2
	6.36	6.06	5.56	5.15	4.41	3.91	3.26	2.86	2.58	2.21	1.96
$\leq 10$	27.6	27.6	28.3	29.3	31.6	33.5	36.3	38.4	40.1	42.7	44.7
	5.78	5.78	5.38	4.89	4.05	3.52	2.88	2.50	2.23	1.88	1.65
$\leq 15$	29.5	29.5	29.7	31.1	34.1	36.5	39.9	42.4	44.4	47.4	49.7
	5.34	5.34	5.27	4.73	3.82	3.28	2.64	2.26	2.01	1.68	1.46
$\leq 20$	31.2	31.2	31.2	32.3	36.0	38.8	42.7	45.5	47.6	50.9	53.4
	4.99	4.99	4.99	4.61	3.65	3.09	2.46	2.09	1.85	1.52	1.31
$\leq 30$	34.1	34.1	34.1	34.2	38.9	42.3	46.9	50.1	53.7	56.3	59.0
	4.46	4.46	4.46	4.43	3.39	2.82	2.19	2.00	1.66	1.30	1.10
$\leq 40$	36.6	36.6	36.6	36.6	41.2	45.0	50.2	53.7	56.3	60.2	63.0
	4.06	4.06	4.06	4.06	3.20	2.62	2.00	1.66	1.43	1.14	0.95
$\leq 60$	40.8	40.8	40.8	40.8	44.5	49.2	55.1	58.9	61.8	65.8	68.6
	3.50	3.50	3.50	3.50	2.92	2.32	1.72	1.40	1.18	0.92	0.75
$\leq 80$	44.3	44.3	44.3	44.3	47.1	52.3	58.7	62.8	65.7	69.7	72.4
	3.10	3.10	3.10	3.10	2.71	2.11	1.52	1.21	1.01	0.76	0.62

Source: *AASHTO LRFD Bridge Design Specifications*, 2014. Used by permission.



**Figure 22.10** Longitudinal strain,  $\epsilon_x$ , for sections containing less than the minimum amount of transverse reinforcement. *AASHTO LRFD Bridge Design Specifications*, 2014. Used by permission

The initial value of  $\epsilon_x$  should not be taken greater than 0.002. If the value of  $\epsilon_x$  from Eq. (22.15) or (22.16) is negative, the strain shall be taken as

$$\epsilon_x = \frac{(|M_u|/d_v) 0.5N_u + 0.5|V_u - V_p| \cot \theta - A_{ps}f_{po}}{2(E_c A_c + E_s A_s + E_p A_{ps})} \quad (22.17)$$

where

- $A_c$  = area of concrete on flexural tension side of member as shown in Fig. 22.9 (in.<sup>2</sup>)
- $A_{ps}$  = area of prestressing steel on flexural tension side of member, as shown in Fig. 22.7 (in.<sup>2</sup>)
- $A_s$  = area of nonprestressed steel on flexural tension side of member at section under consideration, as shown in Fig. 22.7 (in.<sup>2</sup>)
- $f_{po}$  = parameter taken as modulus of elasticity of prestressing tendons multiplied by the locked-in difference in strain between the prestressing tendons and the surrounding concrete (ksi). For usual levels of prestressing, a value of  $0.7f_{pu}$  will be appropriate for both pretensioned and posttensioned members (ksi)
- $N_u$  = factored axial force, taken as positive if tensile and negative if compressive (kip)
- $M_u$  = factored moment, not to be taken less than  $V_u d_v$  (kip-in.)
- $V_u$  = factored shear force (kip)

In order to determine  $\theta$  and  $\beta$  in members with no transverse steel reinforcement or with web reinforcement less than the minimum required, the crack spacing parameter in Table 22.16,  $s_{xe}$ , is needed; it can be estimated as

$$12 \leq s_{xe} = s_x \frac{1.38}{a_g + 0.63} \leq 80 \text{ in.} \quad (22.18)$$

where

- $a_g$  = maximum aggregate size (in.)
- $s_x$  = lesser of either  $d_v$  or maximum distance between layers of longitudinal crack control reinforcement, where the area of the reinforcement in each layer is not less than  $0.003b_v s_x$ , as shown in Fig. 22.9 (in.)

### 22.7.5 Approach 2: Simplified MCFT

AASHTO LRFD 2014 introduces a more simplified version of MCFT, which is explained in this section. In this method, the shear design will follow the same procedure described in Section 22.7.2 with the exception that  $\beta$  and  $\theta$  in steps 3 and 4 to be calculated directly as described next.

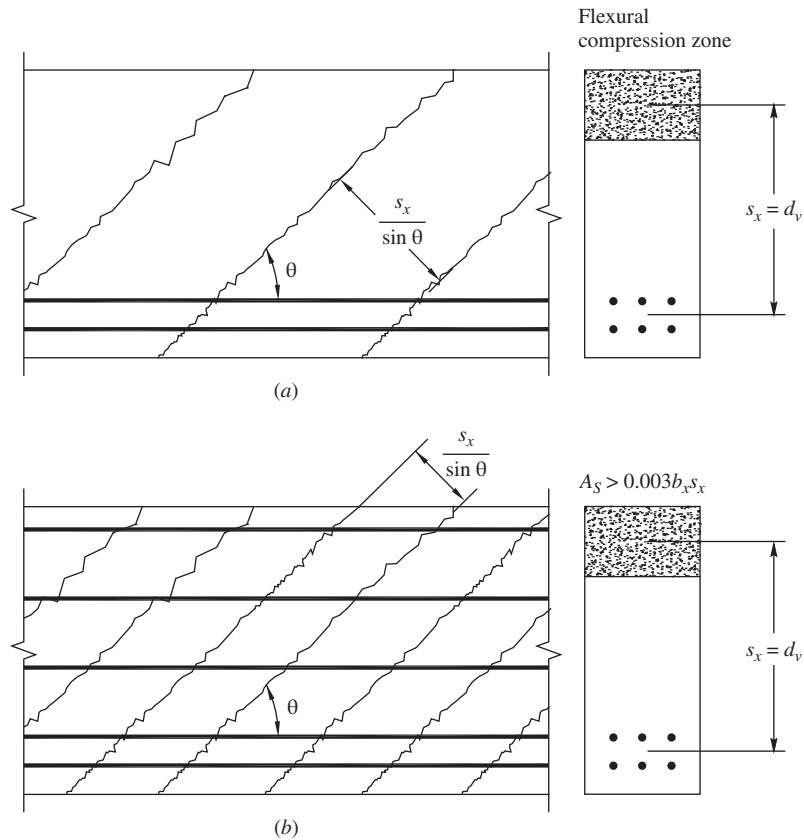
For sections containing at least the minimum amount of transverse reinforcement required by the AASHTO code, the values of  $\beta$  shall be specified as follows:

$$\beta = \frac{4.8}{1 + 750\epsilon_s} \quad (22.19)$$

For sections containing less than the minimum amount of transverse reinforcement required by the AASHTO code, the values of  $\beta$  shall be specified as follows:

$$\beta = \frac{4.8}{1 + 750\epsilon_s} \frac{51}{39 + S_{xe}} \quad (22.20)$$

where  $S_{xe}$  can be calculated from Eq. (22.18).



**Figure 22.11** Definition of crack spacing parameter  $s_x$ . (a) Member without transverse reinforcement and with concentrated longitudinal reinforcement and (b) member without transverse reinforcement but with well-distributed longitudinal reinforcement. *AASHTO LRFD Bridge Design Specifications, 2014. Used by permission.*

The value of  $\theta$  shall be calculated as follows:

$$\theta = 29 + 3500\varepsilon_s \quad (22.21)$$

where  $\varepsilon_s$  is the calculated longitudinal strain at the middepth of the member when the section is subjected to  $N_u$ ,  $M_u$  and  $V_u$ . Longitudinal strain,  $\varepsilon_s$ , can be calculated using the following equation:

$$\varepsilon_s = \frac{\left(\frac{|M_u|}{d_v}\right) + 0.5N_u + |V_u - V_p| - A_p s f_{po}}{(E_s A_s + E_p A_{ps})} \quad (22.22)$$

According to AASHTO,  $\varepsilon_s$  should not be greater than  $6 \times 10^{-2}$ . Two different approaches are suggested when the value of  $\varepsilon_s$  is negative:  $\varepsilon_s$  can be taken equal to zero in the design procedure to be

on the safe side, or can be obtained from the following equation:

$$\varepsilon_s = \frac{\frac{(|M|_u)}{d_v} + 0.5N_u + |V_u - V_p| - A_{ps}f_{po}}{(E_c A_{cf} + E_s A_s + E_p A_{ps})} > -0.0004 \quad (22.23)$$

where  $A_{cf}$  is the area of the section on the flexural tension side of the member.

### 22.7.6 Nominal Shear Resistance (AASHTO 5.8.3.3)

The nominal shear resistance,  $V_n$ , at a given section for the sectional design model is expressed as the sum of contribution from the concrete, the transverse reinforcement, and the transverse component of the prestressing force and shall be determined as the lesser of

$$V_n = V_c + V_s + V_p \quad (22.24)$$

$$V_n = 0.25f'_c b_v d_v + V_p \quad (22.25)$$

in which

$$V_c = 0.0316\beta\sqrt{f'_c}b_v d_v \quad (22.26)$$

$$V_s = \frac{A_v f_y d_v (\cot \theta + \cot \alpha)}{s} \quad (22.27)$$

where

$b_v$  = effective web width taken as minimum web width within depth  $d_v$  (in.)

$d_v$  = effective shear depth (in.)

$s$  = spacing of stirrups (in.)

$\beta$  = factor indicating ability of diagonal compressive stresses

$\alpha$  = angle of inclination of transverse reinforcement to longitudinal axis in degree

$A_v$  = area of shear reinforcement within distance  $s$  (in.<sup>2</sup>)

$V_p$  = component in direction of applied shear of effective prestressing force: positive if resisting applied shear (kip)

$$V_p = F \sin \alpha \quad (22.28)$$

where  $\alpha$  is the angle of inclination of the prestressing force with respect to the longitudinal axis of the beam.

### 22.7.7 Regions Requiring Transverse Reinforcement (AASHTO 5.8.2.4)

Except for slabs, footings, and culverts, transverse reinforcement shall be provided where

$$V_u > \phi 0.5(V_c + V_p) \quad (22.29)$$

### 22.7.8 Minimum Transverse Reinforcement (AASHTO 5.8.2.5)

Except for segmental posttensioned concrete box girder bridges, the area of steel shall satisfy

$$A_v > 0.0316\sqrt{f'_c} \frac{b_v s}{f_y} \quad (22.30)$$

where

$A_v$  = area of transverse reinforcement within distance  $s$  (in<sup>2</sup>.)

$b_v$  = width of web adjusted for presence of ducts

$s$  = spacing of transverse reinforcement (in.)

$f_y$  = yield strength of transverse reinforcement (ksi)

### 22.7.9 Maximum Spacing of Transverse Reinforcement (AASHTO 5.8.2.7)

The spacing of the transverse reinforcement shall not exceed the maximum permitted spacing,  $s_{\max}$ , determined as

If  $v_u < 0.125f'_c$ , then

$$s_{\max} = 0.8d_v \leq 24.0 \text{ in.} \quad (22.31)$$

If  $v_u \geq 0.125f'_c$ , then

$$s_{\max} = 0.4d_v \leq 12.0 \text{ in.} \quad (22.32)$$

### 22.7.10 Minimum Longitudinal Reinforcement (AASHTO 5.8.3.5)

At each section the tensile capacity of the longitudinal reinforcement on the flexural tension side of the member shall be proportioned to satisfy

$$A_{ps}f_{ps} + A_s f_y \geq \frac{M_u}{d_v \phi_f} + 0.5 \frac{N_u}{\phi_c} + \left( \left| \frac{V_u}{\phi_v} - V_p \right| - 0.5V_s \right) \cot \theta \quad (22.33)$$

where

$V_s$  = shear resistance provided by transverse reinforcement at section under investigation  
except  $V_s$  shall not be taken as greater than  $V_u / \phi$  (kip)

$\theta$  = angle of inclination of diagonal compressive stresses used in determining nominal shear resistance of section under investigation

$\phi_f \phi_v \phi_c$  = resistance factors as appropriate for moment, shear, and axial resistance

## 22.8 LOSS OF PRESTRESS (AASHTO 5.9.5)

### 22.8.1 Total Loss of Prestress (AASHTO 5.9.5.1)

Loss of prestress can be characterized as that due to instantaneous loss and time-dependent loss. Losses due to anchorage set, friction, and elastic shortening are instantaneous. Losses due to creep, shrinkage, and relaxation are time dependent.

Total losses = instantaneous losses + time – dependent losses

In pretensioned members:

$$\Delta f_{pT} = \Delta f_{pES} + \Delta f_{pLT} \quad (22.34)$$

In posttensioned members:

$$\Delta f_{pT} = \Delta f_{pF} + \Delta f_{pA} + \Delta f_{pES} + \Delta f_{pLT} \quad (22.35)$$

where

$\Delta f_{pT}$  = total losses (ksi)

$\Delta f_{pF}$  = losses due to friction (ksi)

$\Delta f_{pA}$  = losses due to anchorage set (ksi)

$\Delta f_{pES}$  = sum of all losses or gains due to elastic shortening or extension at time of application of prestress and/or external loads (ksi)

$\Delta f_{pLT}$  = losses due to long-term shrinkage and creep of concrete and relaxation of the steel (ksi)

## 22.8.2 Instantaneous Losses (AASHTO 5.9.5.2)

**22.8.2.1 Anchorage Set (AASHTO 5.9.5.2.1).** Anchorage set loss is caused by the movement of the tendon prior to seating of the wedges or the anchorage gripping device. The magnitude of the anchorage set depends on the prestressing system used and shall be the greater of that required to control the stress in the prestressing steel at transfer or that recommended by the manufacturer of the anchorage. A common value for anchor set is 0.375 in. and can be as low as 0.0625 in.

**22.8.2.2 Friction (AASHTO 5.9.5.2.2).** Losses due to hold-down devices for draping or harping tendons in pretensioned members should be considered.

**Elastic Shortening (AASHTO 5.9.5.2.3).** The loss due to elastic shortening in pretensioned members shall be taken as

$$\Delta f_{pES} = \frac{E_p}{E_{ct}} f_{cgp} \quad (22.36)$$

where

$f_{cgp}$  = concrete stress at center of gravity of prestressing tendons due to prestressing force immediately after transfer and self-weight of member at section of maximum moment (ksi)

$E_p$  = modulus of elasticity of prestressing steel (ksi)

$E_{ct}$  = modulus of elasticity of concrete at transfer or time of load application (ksi)

## 22.8.3 Approximate Estimate of Time-Dependent Losses (AASHTO 5.9.5.3)

The long-term prestress loss due to creep and shrinkage of concrete and relaxation of steel may be estimated using

$$\Delta f_{pLT} = 10.0 \frac{f_{pi} A_{ps}}{A_g} \gamma_h \gamma_{st} + 12.0 \gamma_h \gamma_{st} + \Delta f_{pR} \quad (22.37)$$

in which

$$\gamma_h = 1.7 - 0.01H \quad (22.38)$$

$$\gamma_{st} = \frac{5}{1 + f'_{ci}} \quad (22.39)$$

where

$F_{pi}$  = prestressing steel stress immediately prior to transfer (ksi)

$H$  = average annual ambient relative humidity (%)

$\gamma_h$  = correction factor for relative humidity of ambient air

$\gamma_{st}$  = correction factor for specified concrete strength at time of prestress transfer to concrete member

#### 22.8.4 Refined Estimate of Time-Dependent Losses (AASHTO 5.9.5.4)

The refined method can provide a better estimate of total losses than the approximate method described in the previous section. It is beyond the scope of this book, and readers are encouraged to reference the AASHTO and other references.

### 22.9 DEFLECTIONS (AASHTO 5.7.3.6)

Deflection and camber calculations shall consider dead load, live load, prestressing, erection loads, concrete creep and shrinkage, and steel relaxation (AASHTO 5.7.3.6.2).

It is convenient to consider the total deflections of a prestressed beam as consisting of two parts: instantaneous deflection and long-term deflection. The instantaneous deflection is elastic and is caused by live loads and it does not vary with time. The long-term deflection is caused by sustained loads and increases with time due to creep.

The AASHTO allows to compute the instantaneous deflections using modulus of elasticity for concrete and taking the moment of inertia as either the gross moment of inertia,  $I_g$ , or an effective moment of inertia,  $I_e$ , given as follows:

$$I_e = \left( \frac{M_{cr}}{M_a} \right)^3 I_g + \left[ 1 - \left( \frac{M_{cr}}{M_a} \right) \right] I_{cr} \leq I_g \quad (22.40)$$

in which

$$M_{cr} = f_r \frac{I_g}{y_t} \quad (22.41)$$

where

$M_{cr}$  = cracking moment (kip in.)

$f_r$  = modulus of rupture of concrete

$y_t$  = distance from neutral axis to extreme tension fiber (in.)

$M_a$  = maximum moment in component at stage for which deformation is computed (kip in.)

The AASHTO also allows the long-term deflection to be taken as the instantaneous deflection multiplied by the following factor:

- If the instantaneous deflection is based on  $I_g$ : 4.0
- If the instantaneous deflection is based on  $I_e$ :  $3.0 - 1.2(A'_s/A_s) \geq 1.6$

where

$A'_s$  = area of compression reinforcement (in.<sup>2</sup>)

$A_s$  = area of nonprestressed tension reinforcement (in.<sup>2</sup>)





**MATERIAL PROPERTIES*****PS Steel***

Low relaxation, 0.5-in.-diameter seven-wire strands are used for the problem. Stress limits and properties of prestressing tendons are to be taken as follows (AASHTO Table 5.9.3):

$f_{pu} = 270$ ksi		Prestressed steel ultimate strength
$f_{py} = 0.9 f_{pu}$	$f_{py} = 243$ ksi	Prestressed steel yield strength
$f_{pe} = 0.8 f_{py}$	$f_{pe} = 194.4$ ksi	Strength at service limit state after all losses
$f_{pbt} = 0.9 f_{py}$	$f_{pbt} = 218.7$ ksi	Strength at immediately prior to seating—short-term $f_{pbt}$ may be allowed
$f_{pi} = 202.5$ ksi		Strength at service limit state before losses
$E_{ps} = 28500$ ksi		Modulus of elasticity of strands
$A_{ps-single} = 0.153$ in. <sup>2</sup>		Area of 0.5" diameter strand
$e_m = 27.59$ in.		Eccentricity of PS force at midspan
$e_{end} = 14.17$ in.		Eccentricity of PS force at end span

***Reinforcing Steel***

$f_y = 60$ ksi	Yield strength of reinforcing steel
$E_s = 29,000$ ksi	Modulus of elasticity of reinforcing steel

***Bulb-Tee Girder (BT) (Section 22.1.4)***

$\gamma_c = 150$ pcf	Normal-weight concrete
$f_{c\_BT} = 8.0$ ksi	28-day compressive strength of bulb-tee
$f_{ci\_BT} = 6.0$ ksi	Initial strength at time of initial prestressing of bulb-tee
$E_{ci\_girder} = 33,000(0.15)^{1.5} \sqrt{f'_{ci\_BT}}$ ksi'	Modulus of elasticity of bulb-tees at time of initial prestressing
$E_{ci\_girder} = 4696$ ksi	
$E_{c\_girder} = 33,000(0.15)^{1.5} \sqrt{f'_{c\_BT}}$ ksi'	Elastic modulus of bulb-tee after concrete hardening
$E_{c\_girder} = 5422$ ksi	

***Deck Slab (DS)***

$\gamma_c = 150$ pcf	Normal-weight concrete
$f'_{c\_deck} = 4$ ksi	28-day compressive strength of deck slab
$f_{ci\_deck} = 3.6$ ksi	Initial strength of deck slab
$E_{ci\_deck} = 33000(0.15)^{1.5} \sqrt{f'_{ci\_deck}}$ ksi'	Modulus of elasticity of deck slab
$E_{ci\_deck} = 3637$ ksi	
$E_{c\_deck} = 33000(0.15)^{1.5} \sqrt{f'_{c\_deck}}$ ksi'	Elastic modulus of deck slab after concrete hardening
$E_{c\_deck} = 3834$ ksi	

**TYPICAL SECTION SELECTION**

A precast pretensioned AASHTO-PCI bulb-tee girder (Fig. 2.4) was selected and to be made a composite with the deck.

$t_{\text{top\_flange}} = 3.5 \text{ in.}$	Thickness of top flange
$t_{\text{bottom\_flange}} = 6 \text{ in.}$	Thickness of bottom flange
$t_{\text{web}} = 6 \text{ in.}$	Web thickness
$b_{\text{top\_flange}} = 3.5 \text{ ft}$	Width of top flange
$b_{\text{bottom\_flange}} = 26 \text{ in.}$	Width of bottom flange

**1. Select minimum depth (including deck thickness)**

(Ref: AASHTO 2.5.2.6.3, Table 2.5.2.6.3-1—Simple Span)

Choose  $0.045L$  for a prestressed concrete beam:

$$D_{s\_min} = 0.045L = 0.045(100 \text{ ft}) = 54 \text{ in.} \quad (\text{depth of prestress concrete beam})$$

Assume

$$t_s = 8 \text{ in.} \quad (\text{thickness of top slab})$$

$$h_{\text{girder}} = D_{s\_min} - t_s = 54 \text{ in.} - 8 \text{ in.} = 46 \text{ in.} \quad (\text{minimum depth of beam})$$

Choose BT-63:

$$H = 63 \text{ in.} \quad \text{if } (H > h_{\text{girder}}, \text{“ok”, Reselect}) = \text{“Ok”}$$

A minimum 1'' thick haunch will be used:

$$t_{\text{haunch}} = 1 \text{ in.}$$

Therefore, total structure depth is

$$D_S = H + t_s + t_{\text{haunch}} = 63 \text{ in.} + 8 \text{ in.} + 1 \text{ in.} = 72 \text{ in.}$$

**2. Select Girder Spacing**

Recommendation:	$S < 2D_s$	$S$ is a center-to-center girder spacing
	$\text{OH} < 2S$	OH is overhang length

Try

$$S = 9 \text{ ft}$$

$$\text{if } (S \leq 2D_s, \text{“OK”, “NG”}) = \text{“OK”}$$

A length of overhang is computed as

$$\text{OH} = \frac{w_{\text{bridge}} - (n_g - 1)S}{2} = \frac{34.83 \text{ ft} + (4 - 1)9 \text{ ft}}{2} = 3.915$$

$$\text{if } (\text{OH} \leq 2S, \text{“OK”, “NG”}) = \text{“OK”}$$

**3. Check Minimum Thickness (AASHTO 5.14.1.2.2)**

The thickness of any part of precast concrete beams shall not be less than:

Top flange = 2.0 in.	if ( $t_{\text{top\_flange}} \geq 2$ in., “OK”, “NG”) = “OK”
Web, non-posttensioned = 5.0 in.	if ( $t_{\text{bottom\_flange}} \geq 5$ in., “OK”, “NG”) = “OK”
Bottom flange = 5.0 in.	if ( $t_{\text{web}} \geq 5$ in., “OK”, “NG”) = “OK”

**4. Effective Flange Width (Ref. (Section 22.5.3.5) & AASHTO 4.6.2.6.1)**

$$\text{OH} = 3.915 \text{ ft} \quad (\text{Length of overhang})$$

**Interior Girder**

$$b_{\text{eff\_int}} = \min \left( \frac{L_{\text{eff}}}{4}, 12t_s + \max \left( t_{\text{web}}, \frac{t_{\text{top\_flange}}}{2} \right), S \right)$$

where

$L_{\text{eff}} = L = 100$ ft	Effective span length
$t_s = 8$ in.	Average depth of the slab
$t_{\text{web}} = 6$ in.	Web thickness
$S = 9$ ft	Centerline-to-centerline spacing of interior girders
$t_{\text{top\_flange}} = 3.5$ ft	Width of the top flange of the girder

Therefore, effective flange width of the composite section for an interior girder is computed as

$$\begin{aligned} b_{\text{eff\_int}} &= \min \left( \frac{L_{\text{eff}}}{4}, 12t_s + \max \left( t_{\text{web}}, \frac{t_{\text{top\_flange}}}{2} \right), S \right) \\ &= \min \left( \frac{100 \text{ ft}}{4}, 12(8 \text{ in.}) + \max \left( 6, \frac{3.5 \text{ in.}}{2} \right), 9 \text{ ft} \right) = 8.5 \text{ ft} \end{aligned}$$

**Exterior Girder**

$$b_{\text{eff\_ext}} = \min \left( \frac{L_{\text{eff}}}{8}, 6t_s + \max \left( \frac{t_{\text{web}}}{2}, \frac{t_{\text{top\_flange}}}{4} \right), \text{OH} \right)$$

where

$$\text{OH} = 3.915 \text{ ft} \quad (\text{length of overhang})$$

Therefore, effective flange width of the composite section for an exterior girder is computed as

$$\begin{aligned} b_{\text{eff\_int}} &= \min \left( \frac{L_{\text{eff}}}{8}, 6t_s + \max \left( \frac{t_{\text{web}}}{2}, \frac{t_{\text{top\_flange}}}{4} \right), \text{OH} \right) \\ &= \min \left( \frac{100 \text{ ft}}{8}, 6(8 \text{ in.}) + \max \left( \frac{6}{2}, \frac{3.5 \text{ in.}}{4} \right), 3.915 \text{ ft} \right) = 3.915 \text{ ft} \end{aligned}$$

**5. Select Resistance Factors (AASHTO 5.5.4.2)**

For tension-controlled prestressed concrete sections	1.0
For shear and torsion (normal-weight concrete)	0.9
For compression in anchorage zones (normal-weight concrete)	0.8
For tension in steel in anchorage zones	1.0

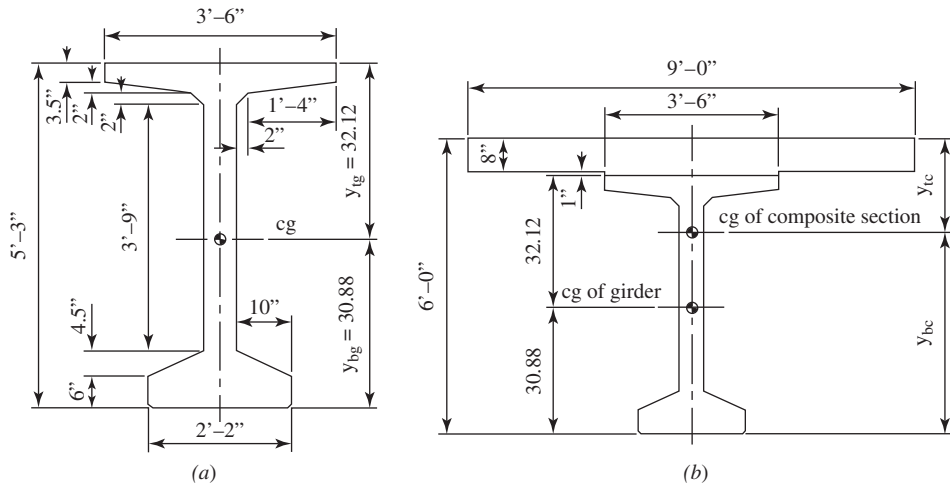


Figure 22.13 Typical sections of (a) BT-63 and (b) composite section.

**SECTION PROPERTIES (AASHTO PCI BT-63) (FIG. 22.13)**

**1. BT-63 Section Properties**

$A_g = 713 \text{ in.}^2$	Area of BT-63 girder
$I_g = 392638 \text{ in.}^4$	Moment inertial of BT-63 girder
$H_g = 5.25 \text{ ft}$	Height of BT-63 girder
$y_{bg} = 32.12 \text{ in.}$	Center of gravity of BT-63 girder from the bottom
$y_{tg} = H - y_{bg} = 30.88 \text{ in.}$	Center of gravity of BT-63 girder from the top
$S_{bg} = \frac{I_g}{y_{bg}} = 12224 \text{ in.}^3$	Bottom section modulus of BT-63 girder
$S_{tg} = \frac{I_g}{y_{tg}} = 12715 \text{ in.}^3$	Top section modulus of BT-63 girder

**2. Composite Section Properties**

$t_{\text{haunch}} = 1 \text{ in.}$	Thickness of haunch may be neglected conservatively in section properties
$D_s = 6 \text{ ft}$	Depth of composite section

To transform the cast-in-place deck slab into equivalent girder concrete, the following modular ratio will be applied:

$$n = \frac{E_{c\_deck}}{E_{c\_girder}} = 0.707$$

Section properties for the composite section are calculated below.

$$A_{deck} = nb_{\text{eff\_int}}t_s = (0.707)(8.5 \text{ ft})(8 \text{ in.}) = 577 \text{ in.}^2$$

(Area of transformed deck)

$$A_{\text{haunch}} = nb_{\text{top\_flange}}t_{\text{haunch}} = (0.707)(3.5 \text{ ft})(1 \text{ in.}) = 29.7 \text{ in.}^2$$

(Area of transformed haunch)

$$A_{\text{gc}} = A_{\text{deck}} = A_{\text{haunch}} + A_g = 577 + 29.7 + 713 = 1319.7 \text{ in.}^2$$

(Area of transformed composite section)

Centroids of the composite section are calculated as below:

$$\begin{aligned} y_{\text{tc}} &= \frac{[A_g(y_{\text{tg}} + t_{\text{haunch}} + t_s)] + \left[A_{\text{haunch}} \left(t_s + \frac{1}{2}t_{\text{haunch}}\right)\right] + \left(A_{\text{deck}}\frac{1}{2}t_s\right)}{A_{\text{gc}}} \\ &= \frac{\left[(577)(30.88 + 1 + 8) + (29.7)\left(8 + \frac{1}{2}\right) + \left(577\frac{8}{2}\right)\right]}{1319.7} \\ &= 23.49 \text{ in.} \end{aligned}$$

$$y_{\text{bc}} = D_s - y_{\text{tc}} = 72 - 23.49 = 48.51 \text{ in.}$$

$$y_{\text{ic}} = y_{\text{tc}} - t_{\text{haunch}} - t_s = 23.49 - 1 - 8 = 14.49 \text{ in.}$$

$$\begin{aligned} I_{\text{deck}} &= \frac{1}{12}(b_{\text{eff\_int}}t_s^3) = \frac{1}{12}(8.5 \times 12)(8)^3 && \text{Moment of inertia of deck} \\ &= 4.352 \times 10^3 \text{ in.}^4 \end{aligned}$$

$$\begin{aligned} I_{\text{haunch}} &= \frac{1}{12}(\text{OH}t_{\text{haunch}}^3) = \frac{1}{12}(3.915 \times 12)(1)^3 && \text{Moment of inertia of haunch} \\ &= 3.915 \text{ in.}^4 \end{aligned}$$

$$\begin{aligned} I_{\text{gc}} &= I_{\text{deck}} + A_{\text{deck}} \left(y_{\text{tc}} - \frac{1}{2}t_s\right)^2 + I_{\text{haunch}} && \text{Moment of inertia of composite section} \\ &\quad + A_{\text{haunch}} \left(y_{\text{tc}} - t_s - \frac{1}{2}t_{\text{haunch}}\right)^2 \\ &= 4352 + (577)\left(23.49 - \frac{8}{2}\right)^2 + 3.9 \\ &\quad + 29.7\left(23.49 - 8 - \frac{1}{2}\right)^2 \\ &\quad + 39.263 + (577)(48.51 - 30.88)^2 \\ &= 844465 \text{ in.}^4 \end{aligned}$$

$$S_{\text{tc}} = \frac{I_{\text{gc}}}{y_{\text{tc}}} = \frac{844,456}{23.49} = 35,956 \text{ in.}^3 \quad \text{Section modulus to top of deck}$$

$$S_{\text{bc}} = \frac{I_{\text{gc}}}{y_{\text{bc}}} = \frac{844,456}{48.51} = 17,407 \text{ in.}^3 \quad \text{Section modulus to bottom of girder}$$

$$S_{\text{ic}} = \frac{I_{\text{gc}}}{y_{\text{ic}}} = \frac{844,456}{14.99} = 58,294 \text{ in.}^3 \quad \text{Section modulus to bottom of deck}$$

## LOADS ANALYSIS

### Dead Loads

#### 1. Interior Girders

**DC1:** Dead load of structural components

$$\gamma_c = 150 \text{ pcf}$$

$$w_{\text{slab\_int}} = \gamma_c t_s b_{\text{eff\_int}} = (0.15) \left( \frac{8}{12} \right) (8.5) = 0.85 \text{ klf} \quad \text{Self-weight of slab at interior girders}$$

$$w_{\text{haunch\_int}} = \gamma_c b_{\text{top\_flange}} t_{\text{haunch}} = (0.15)(3.5) \left( \frac{1}{12} \right) = 0.44 \text{ klf} \quad \text{Self-weight of haunch at interior girders}$$

$$w_{\text{g\_int}} = \gamma_c A_g = (0.15) \left( \frac{713}{144} \right) = 0.743 \text{ klf} \quad \text{Self-weight of interior girder}$$

Typically, intermediate diaphragm should be provided for later stability. However, intermediate diaphragm weight is ignored in calculations for simplicity.

$$w_{\text{DC1\_int}} = w_{\text{slab\_int}} + w_{\text{haunch\_int}} + w_{\text{g\_int}} = 0.85 + 0.044 + 0.793 = 1.636 \text{ klf}$$

Uniform weight of dead loads at interior girder includes girder, deck, and haunch

where

$\gamma_c = 150 \text{ pcf}$	Unit weight of concrete
$t_s = 8 \text{ in.}$	Thickness of deck
$t_{\text{haunch}} = 1 \text{ in.}$	Thickness of haunch
$t_{\text{eff\_in}} = 8.5 \text{ ft}$	Effective width of deck
$t_{\text{top\_flange}} = 3.5 \text{ ft}$	Effective flange width

**DC2:** Dead load of structural components and attachment after girder hardened

$$w_{\text{barrier}} = \frac{n_b}{n_g} \gamma_c \left[ \frac{w_{\text{barrier\_top}} + w_{\text{barrier\_bottom}}}{2} b_{\text{barrier}} - (1.5 \text{ ft} - 4 \text{ in.}) \right]$$

$$= \frac{2}{4} (0.15) \left[ \frac{1 + 1.417}{2} (2.67) - (1.5) \left( \frac{4}{12} \right) \right] = 0.205 \text{ klf}$$

Weight of concrete barrier distributed equally to all girders. If there are fences or other attachment, weight should be adjusted.

$$w_{\text{DC2\_int}} = w_{\text{barrier}} = 0.205 \text{ klf}$$

**DW:** Added dead loads and future utilities.

$$\gamma_{\text{AC\_wearing}} = 35 \text{ pcf} \quad \text{Assume 35 psf AC overlay}$$

$$w_{\text{AC\_wearing}} = \gamma_{\text{AC\_wearing}} (w_{\text{bridge}} - 2w_{\text{barrier\_bottom}})$$

$$= (0.035)[34.83 - 2(1.417)]$$

$$w_{\text{AC\_wearing}} = 1.12 \text{ klf} \quad \text{Weight of AC wearing}$$

$$w_{\text{DW\_int}} = \frac{w_{\text{AC\_wearing}}}{n_g} = \frac{1.12}{4} = 0.28 \text{ klf} \quad \text{Weight of AC wearing distributed equally to all girders}$$

**2. Exterior Girders****DC1:** Dead load of structural components

$$\begin{aligned}
 w_{\text{slab\_ext}} &= \gamma_c t_c \left( \frac{S}{2} + \frac{\text{OH}}{2} \right) && \text{Weight of slab at exterior girders} \\
 &= (6.15) \left( \frac{8}{12} \right) \left( \frac{9}{2} + \frac{3.915}{2} \right) \\
 &= 0.646 \text{ klf}
 \end{aligned}$$

$$w_{\text{haunch\_ext}} = w_{\text{haunch\_int}} = 0.044 \text{ klf} \quad \text{Weight of haunch at exterior girders}$$

$$\begin{aligned}
 w_{\text{oh}} &= \gamma_c \left( \frac{t_{\text{oh\_ext}} + t_{\text{oh\_int}}}{2} \right) L_{\text{oh}} && \text{Weight of overhang} \\
 &= (0.15) \left( \frac{0.67 + 1}{2} \right) (3.915) = 0.278 \text{ klf}
 \end{aligned}$$

$$\begin{aligned}
 w_{\text{DC1\_ext}} &= w_{\text{slab\_ext}} + w_{\text{haunch\_ext}} + w_{\text{g\_int}} && \text{Uniform weight of dead loads at exterior} \\
 &= 0.646 + .044 + 0.743 && \text{girder includes: girder, deck, and haunch} \\
 &= 1.432 \text{ klf}
 \end{aligned}$$

**DC2:** Dead load of structural components and attachment after girder hardened

$$w_{\text{DC2\_ext}} = w_{\text{DC2\_int}} = 0.205 \text{ klf} \quad \text{Weight of concrete barrier}$$

**DW:** Added dead load and future utilities

$$w_{\text{Dw\_ext}} = w_{\text{Dw\_int}} = 0.28 \text{ klf} \quad \text{Weight of AC wearing}$$

**LIVE-LOAD FORCE EFFECTS****1. Select number of lanes,  $N_L$** 

$$N_L = \text{floor} \left( \frac{w}{12 \text{ ft}} \right) = 2 \quad \begin{array}{l} \text{Number of live-load lanes is taken care of by} \\ \text{live-load distribution factors.} \\ \text{AASHTO 3.6.1.1.2} \end{array}$$

**2. Multiple presence factor,  $m$**  (AASHTO 3.6.1.1.2, Table 3.6.1.1.2-1)

The effect of multiple presence factor is incorporated into distribution factors.

	<i>No. of loaded lanes</i>	<i>m</i>
$m = 1$	1	1.2
	2	1
	3	0.85
	> 3	0.65

**3. Dynamic allowance, IM** (AASHTO 3.6.2.1)

	<i>Component</i>	<i>IM (%)</i>
IM = 33%	<i>Deck joints</i>	75
	<i>Fatigue</i>	15
	<i>All other</i>	33

**4. Distribution factors for moment (AASHTO 4.6.2.2.1-1)**

Cross section,  $k$  (Table 2.2, Table 4.6.2.2.1-1)

$$\begin{aligned}
 I_g &= 392638 \text{ in.}^4 && \text{Moment of inertia of girder} \\
 A_g &= 713 \text{ in.}^2 && \text{Area of girder} \\
 e_g &= y_{\text{tg}} + t_{\text{haunch}} + \frac{1}{2}t_s = 30.88 + 1 + \frac{8}{2} \\
 &= 35.88 \text{ in.} && \text{Distance between the center of gravity of the} \\
 &&& \text{basic girder and the center of gravity of deck} \\
 K_g &= n(I_g + A_g e_g^2) && \text{Stiffness factor (Eq. 4.6.2.2.1-1)} \\
 &= (0.707)[392638 + (713)(35.88)^2] \\
 &= 926,689 \text{ in.}^4
 \end{aligned}$$

*Interior Girders* (AASHTO 4.6.2.2.1-1)

a. For one design lane loaded:

$$\begin{aligned}
 DM_{\text{int1}} &= 0.06 + \left(\frac{S}{14 \text{ ft}}\right)^{0.4} \left(\frac{S}{L}\right)^{0.3} \left[\frac{K_g}{12 \text{ ft} (t_s^3)}\right]^{0.1} \\
 &= 0.06 + \left(\frac{9}{14}\right)^{0.4} \left(\frac{9}{100}\right)^{0.3} \left(\frac{926,689}{12 \times 8^3}\right)^{0.1} \\
 DM_{\text{int1}} &= 0.584 \text{ lane}
 \end{aligned}$$

b. For two or more design lanes loaded:

$$\begin{aligned}
 DM_{\text{int2}} &= 0.075 + \left(\frac{S}{9.5 \text{ ft}}\right)^{0.6} \left(\frac{S}{L}\right)^{0.2} \left[\frac{K_g}{12 \text{ ft} (t_s^3)}\right]^{0.1} \\
 &= 0.075 + \left(\frac{9}{9.5}\right)^{0.6} \left(\frac{9}{100}\right)^{0.2} \left(\frac{926,689}{12 \times 8^3}\right)^{0.1} \\
 DM_{\text{int2}} &= 0.845 \text{ lane} * \text{Controls}
 \end{aligned}$$

Distribution factors for moment at the interior girder:

$$DM_{\text{int}} = \max(DM_{\text{int1}}, DM_{\text{int2}}) = 0.845 \text{ lane} \quad \textbf{Therefore, use DF_MI = 0.845 lane}$$

*Exterior Girders* (Fig. 22.14) (AASHTO 4.6.2.2.1-1)

a. For one design lane loaded Lever Rule:

$$d_1 = S + OH - w_{\text{barrier\_bottom}} - 2 \text{ ft} = 9 + 3.915 - 1.417 - 2 = 9.498 \text{ ft}$$

Distance from hinge point to a wheel closer to barrier:

$$d_2 = d_1 - 6 \text{ ft} = 9.498 - 6 = 3.498 \text{ ft}$$

Distance from hinge point to a wheel closer to the hinge point:

$$R = \left[ \frac{P}{2} \left( \frac{d_1 + d_2}{S} \right) \right] = \frac{P}{2} \left( \frac{9.498 + 3.498}{9} \right) = 0.72P$$

Resultant force at exterior girder:

$$DM_{\text{ext1}} = mR \quad DM_{\text{ext1}} = 0.72 \text{ lane} * \textbf{Controls}$$



b. For two or more design lanes loaded:

$$d_e = OH - w_{\text{barries\_bottom}} = 3.915 - 1.417 = 2.498 \text{ ft}$$

$$e = 0.77 + \frac{d_e}{9.1 \text{ ft}} = 0.77 + \frac{2.498}{9.1} = 1.045 \text{ ft}$$

$$DM_{\text{ext}2} = e \cdot DM_{\text{in}2} = 1.045 \times 0.845 = 0.883$$

Distribution factors for moment at the exterior girder:

$$DM_{\text{ext}} = \max(DM_{\text{ext}1}, DM_{\text{ext}2}) = 0.883 \text{ lane} \quad \textbf{Therefore, use DF\_ME = 0.883 lane}$$

**5. Distribution factors for shear**

*Interior Girders* (AASHTO 4.6.2.2.3a)

a. For one design lane loaded:

$$DV_{\text{int}1} = 0.36 + \frac{S}{25 \text{ ft}} = 0.36 + \frac{9}{25} = 0.72 \text{ lane}$$

b. For two or more design lanes loaded:

$$DV_{\text{int}2} = 0.2 + \left(\frac{S}{12 \text{ ft}}\right) - \left(\frac{S}{35 \text{ ft}}\right)^2 = 0.2 + \left(\frac{9}{12}\right) - \left(\frac{9}{35}\right)^2 = 0.884 \text{ lane} \quad \textbf{* Controls}$$

Distribution factors for shear at the interior girder:

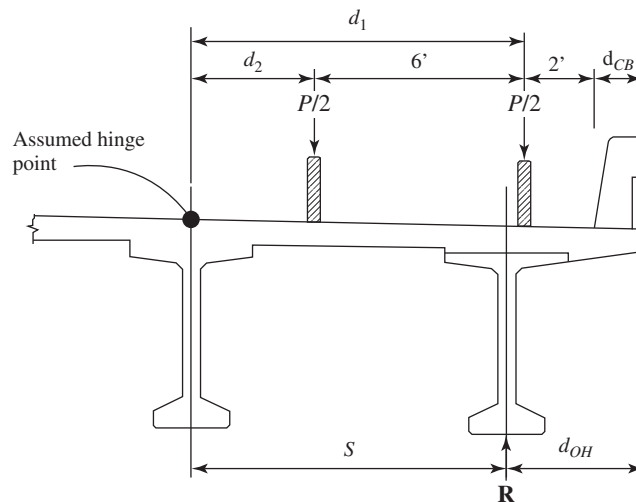
$$DV_{\text{int}} = \max(DV_{\text{int}1}, DV_{\text{int}2}) = 0.884 \text{ lane} \quad \textbf{Therefore, use DF\_VI = 0.884 lane}$$

*Exterior Girders* (AASHTO 4.6.2.2.3b)

a. For one design lane loaded:

$$DV_{\text{ext}1} = 1.2 \textbf{* Controls}$$

$$e = 0.6 + \frac{d_e}{10 \text{ ft}} = 0.6 + \frac{2.998}{10} = 0.85 \text{ lane}$$



**Figure 22.14** FBD of lever rule.

b. For two or more design lanes loaded:

$$DV_{\text{ext}2} = e \cdot DV_{\text{int}2} = 0.85(0.884) = 0.751$$

Distribution factors for shear at the exterior girder:

$$DV_{\text{ext}} = \max(DV_{\text{ext}1}, DV_{\text{ext}2}) = 1.2 \text{ lane} \quad \textbf{Therefore, use DF\_VE} = 1.2 \text{ lane}$$

#### 6. Skew correction factor for shear (AASHTO 4.6.2.2.3c)

$\theta = 0$  Exterior and first interior beams on the obtuse side

$$SC = 1.0 + 0.2 \left[ \frac{12Ll_s^3}{K_g} \right]^{0.3} \quad \tan \theta = 1.0 + 0.2 \left[ \frac{12 \times 100 \times 8^3}{926,689} \right] \tan(0) = 1$$

Typically, maximum moments and shears are governed by live (truck) loads. In this case, interior girders will likely govern the design and a sample calculation will be performed for an interior girder design only.

### MOMENT DEMANDS

The maximum moments due to dead loads and live loads occur at the midspan. Calculate the maximum moment due to dead loads.

#### Unfactored Moment

##### 1. Dead Load

$$x = 0.5L = 50 \text{ ft}$$

Distance at midspan from the left of the bridge

$$W_{\text{DC1\_NC}} = w_{\text{g\_int}} = 0.743 \text{ klf}$$

Dead-load unit weight due to noncomposite section (DC1): girder only

$$\begin{aligned} M_{\text{DC1\_NC}} &= \frac{w_{\text{DC1\_NC}} x(L-x)}{2} \\ &= \frac{(0.743)(50)(100-50)}{2} \\ &= 928.4 \text{ kip} \cdot \text{ft} \end{aligned}$$

Maximum moment due to noncomposite section

$$\begin{aligned} w_{\text{DC1\_C}} &= w_{\text{slab\_int}} + w_{\text{haunch\_int}} \\ &= 0.85 + 0.044 = 0.894 \text{ klf} \end{aligned}$$

Dead-load unit weight due to composite section (DC1): deck slab and haunch

$$\begin{aligned} M_{\text{DC1\_C}} &= \frac{w_{\text{DC1\_C}} x(l-x)}{2} \\ &= \frac{(0.894)(50)(100-50)}{2} \\ &= 1117.2 \text{ kip} \cdot \text{ft} \end{aligned}$$

Maximum moment acting on hardened girder: composite section

The maximum moment due to DC1: girder, deck, and haunch

$$M_{\text{DC1}} = M_{\text{DC1\_NC}} + M_{\text{DC1\_C}} = 928.4 + 1117.2 = 2045.6 \text{ kip} \cdot \text{ft}$$

The maximum moment due to DC2: railing and future utilities

$$M_{\text{DC2}} = \frac{w_{\text{DC2\_int}} x(L-x)}{2} = \frac{(0.205)(50)(100-50)}{2} = 255.6 \text{ kip} \cdot \text{ft}$$

The maximum moment due to DW: future wearing surface (AC overlay)

$$M_{DW} = \frac{w_{DW\_int}x(L-x)}{2} = \frac{(0.28)(50)(100-50)}{2} = 350 \text{ kip} \cdot \text{ft}$$

## 2. Live Load

Maximum moment due to uniform lane load of 0.64 klf:

$$M_{\text{uniformLL}} = \frac{(0.64 \text{ klf})x(L-x)}{2} = \frac{(0.64)(50)(100-50)}{2} = 800 \text{ kip} \cdot \text{ft}$$

Maximum moment due to design truck of HL-93 without dynamic load allowance

$$\begin{aligned} M_{HL93} &= 16 \text{ kip} \left( \frac{9}{8}L + \frac{24.5 \text{ ft}^2}{L} - 17.5 \text{ ft} \right) = 16 \left( \frac{9}{8}(100) + \frac{24.5}{100} - 17.5 \right) \\ &= 1523.9 \text{ kip} \cdot \text{ft} \end{aligned}$$

Maximum moment due to design tandem without dynamic load allowance

$$M_{\text{Tandem}} = 50 \text{ kip} \left( \frac{L}{4} - 1 \text{ ft} - \frac{3 \text{ ft}^2}{L} \right) = 50 \left( \frac{100}{4} - 1 - \frac{3}{100} \right) = 1198.5 \text{ kip} \cdot \text{ft}$$

$$M_{\text{truck}} = \text{Max}(M_{HL93}, M_{\text{Tandem}}) = \text{max}(1523.9, 1198.5) = 1523.9 \text{ kip} \cdot \text{ft}$$

Therefore, design truck will govern the maximum moment [combination (b) in Fig. 22.8].

### ***Pedestrian Live Load (AASHTO 3.6.1.6)***

Pedestrian load of 0.075 klf shall be applied to all sidewalks wider than 2.0 ft with vehicular live load in vehicle lane.

If no side walk provided, therefore, no pedestrian live load is applied.

The maximum moment due to live load including the effects of dynamic load allowance and load distribution factor is calculated below:

$$M_{LL} = DM_{\text{int}} \{ M_{\text{uniformLL}} + [(1 + IM)M_{\text{truck}}] \} = 0.845[800 + (1 + 0.33)1523.9] = 2389.7 \text{ kip} \cdot \text{ft}$$

## **FACTORED MOMENTS**

### ***Factored Moments***

#### *Load Factor Combinations:*

Use for girder design-working stress

Strength I	1.25(DC) + 1.5 (DW) + 1.75(LL + IM)
Service I	1.0[DC + DW + (LL + IM)]; HL 93 only
Service III	1.0[DC + DW + 0.8(LL + IM)]; HL 93 only

$$\begin{aligned} \text{Strength I} &= 1.25(M_{DC1} + M_{DC}) + 1.5(M_{DW}) + 1.75(M_{LL}) \\ &= 1.25(2045.6 + 255.6) + 1.5(350) + 1.75(2389.7) = 7583 \text{ kip} \cdot \text{ft} \end{aligned}$$

$$\begin{aligned} \text{Service I} &= 1.0(M_{DC1} + M_{DC2} + M_{DW} + M_{LL}) = 1.0(2045.6 + 255.6 + 350 + 2389.7) \\ &= 5041 \text{ kip} \cdot \text{ft} \end{aligned}$$

$$\begin{aligned} \text{Service III} &= 1.0(M_{DC1} + M_{DC2} + M_{DW} + 0.8M_{LL}) \\ &= 1.0[2045.6 + 255.6 + 350 + 0.8(2389.7)] = 4563 \text{ kip} \cdot \text{ft} \end{aligned}$$

**WORKING STRESS DESIGN**

**Allowable Stress** (AASHTO Table 5.9.4.1.2-1, Table 5.9.4.2.1-1, and Table 5.9.4.2.2-1)

1. Temporary tensile stress limit in prestressed concrete before losses, fully prestressed components

In area with bonded reinforcement sufficient to resist the tensile force in the concrete computed assuming an uncracked section shall be  $0.24\sqrt{f'_{CI}}$  (ksi).

$$f_{ti\_a} = 0.24\sqrt{f'_{ci\_BT}} \text{ ksi} = 0.24\sqrt{6} = 0.588 \text{ ksi}$$

2. Compressive stress limits in prestressed concrete at service limit state after losses, fully prestressed components

$$f_{ci\_a} = 0.6f'_{ci\_BT} = 3.6 \text{ ksi}$$

Temporary compressive stress limit before losses, fully prestressed components

$$f_{c1\_a} = 0.6f'_{c\_BT} = 0.6(8) = 4.8$$

Final compressive stress limit due to effective prestress, permanent loads, transient loads during shipping and handling

$$f_{c\_deck\_a} = 0.6f'_{c\_deck} = 0.6(4) = 2.4 \text{ ksi}$$

Final compressive stress limit due to deck slab, effective prestress, permanent, transient loads during shipping and handling

$$f_{c2\_a} = 0.45f'_{c\_BT} = 0.45(8) = 3.6 \text{ ksi}$$

Final compressive limit stress at service limit state after losses due to effective prestress and permanent loads

$$f_{c3\_a} = 0.4f'_{c\_BT} = 0.4(8) = 3.2 \text{ ksi}$$

Final compression – live load + one-half the sum of effective prestress and permanent loads

3. Tensile stress limits in prestressed concrete at service limit state after losses, fully prestressed components

For components with bonded prestressing tendons that are subjected to not worse than moderate corrosion conditions shall be

$$f_{tf\_a} = 0.19\sqrt{f'_{c\_BT}} \text{ ksi} = 0.19\sqrt{8} = 0.537 \text{ ksi}$$

The minimum value of prestress force  $F_f$  to ensure that the tension in the bottom fiber of the girder at midspan does not exceed the allowable stress of  $f_{tf}$  (ksi) in the composite section under final service condition can be expressed as follows:

$$f_{bg} = \frac{-F_f}{A_g} - \frac{F_f e_m}{S_{bg}} + \frac{M_{DC1} + M_{DC2}}{S_{gb}} + \frac{M_{DW} + 0.8M_{LL}}{S_{bc}} \leq f_{tf\_a}$$

where

$$e_m = 27.59 \text{ in.}$$

Distance from center of gravity of girder to centroid of pretensioned strands

$$M_{DC1} = 2045.6 \text{ kip} \cdot \text{ft}$$

Moment due to self-weight of girder

$M_{DC2} = 255.628 \text{ kip} \cdot \text{ft}$	Moment due to dead load of wet concrete:slab + haunch
$M_{DW} = 349.956 \text{ kip} \cdot \text{ft}$	Moment due to added dead load after girder hardens
$M_{LL} = 2389.7 \text{ kip} \cdot \text{ft}$	Moment due to live load + dynamic load allowance (Service III)

$$F_f = \frac{0.537 \text{ ksi} - \frac{(M_{DC1} + M_{DC2})12 \text{ in./ft}}{S_{bg}} - \frac{(M_{DW} + 0.8M_{LL})12 \text{ in./ft}}{S_{bc}}}{-1/A_g - e_m/S_{bg}}$$

$$= \left[ \frac{0.537 - (2045.6 + 255.6)(12)/17409 - [350 + 0.8(2389.7)](12)}{-1/713 - 27.59/12229} \right] = 896.6 \text{ kip} \cdot \text{ft}$$

Stress in strands after all losses. Typically assume  $\Delta f_{pT} = 35.0 \text{ ksi}$ , and this value will be refined.

$$\Delta f_{pT} = 35 \text{ ksi}$$

$$f_e = f_{pe} - \Delta f_{pT} = 194.4 - 35 = 159.4 \text{ ksi}$$

$$A_{ps} = \frac{F_f}{f_e} = \frac{896.6}{159.4} = 5.625 \text{ in.}^2 \quad \text{Total area of strands required}$$

$$N_{ps} = \text{ceil} \left( \frac{A_{ps}}{A_{ps\_single}} \right) = \text{ceil} \left( \frac{5.625}{0.153} \right) = 37; \quad \text{use } N_{ps} = 38$$

Total number of 0.5 in. diameter stands required. Even number of strands may be used as shown in Figure 22.15 under strand pattern.

#### 4. Strand Pattern

##### At Midspan

$$N_{y\_m} = 172 \text{ in.}$$

$$y_m = \frac{N_{y\_m}}{N_{ps}} = \frac{172}{38} = 4.526 \text{ in.}$$

$$e_m = y_{bg} - y_m = 32.12 - 4.526 = 27.59 \text{ in.}$$

##### At End Section

$$N_{y\_e} = 682 \text{ in.}$$

$$y_{end} = \frac{N_{y\_e}}{N_{ps}} = \frac{682}{38} = 17.947 \text{ in.}$$

$$e_{end} = y_{bg} - y_{end} = 32.12 - 17.947 = 14.17 \text{ in.}$$

#### 5. Prestress Losses

##### a. Instantaneous Losses, $\text{Inst\_Loss}$ (AASHTO 5.9.5.2)

Instantaneous losses are losses due to anchorage set, friction, and elastic shortening.

##### *Friction*

The only friction loss possible in a pretensioned member is at holddown devices for draping or harpening tendons. The LRFD specifications specify the consideration of these losses.

##### *Elastic Shortening, $\Delta f_{ES}$* (AASHTO 5.9.5.2.3)

$$E_p = 28500 \text{ ksi}$$

Modulus of elasticity of prestressing steel

$$E_{ci} = E_{ci\_girder} = 4.696 \times 10^3 \text{ ksi}$$

Modulus of elasticity of concrete at transfer

$$M_g = M_{DC1\_NC} = 928.385 \text{ kip} \cdot \text{ft}$$

Midspan moment due to member self-weight

At Midspan			At End Section		
$N$	$y$	$N_y$	$N$	$y$	$N_y$
12	2	24	10	2	24
12	4	48	10	4	48
8	6	48	6	6	48
4	8	32	2	8	32
2	10	20	0	10	20
0	53	48	2	53	106
0	55	32	2	55	110
0	57	20	2	57	114
0	59	0	2	59	118
0	61	0	2	61	122
38		172	38		682

Harped strands

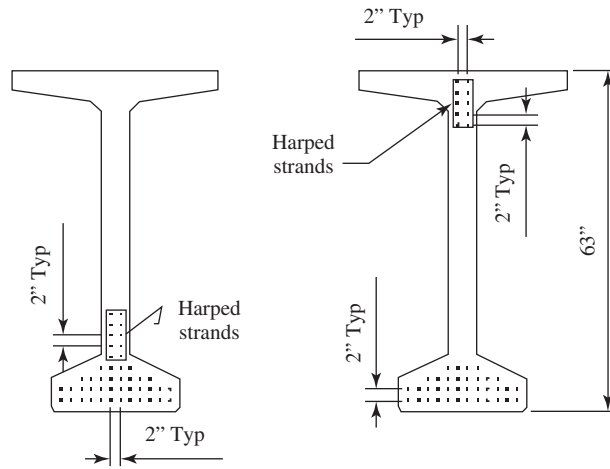


Figure 22.15 Strand pattern.

$$\Delta f_{pES} = \frac{A_{ps} f_{pbt} (I_g + e_m^2 A_g) - e_m M_g A_g}{A_{ps} (I_g + e_m^2 A_g) + A_g I_g (E_{ci} / E_p)} \text{ AASHTO 5.9.5.2.3a - 1}$$

$$= \frac{(5.625)(218.7)[392,638 + 27.59^2(713)] - 29.59(928.4)(713)}{(5.625)[392,638 + 27.59^2(713)] + (713)(392638)(4696/28500)}$$

$$\Delta f_{pES} = 18.129 \text{ ksi}$$

$$\text{Inst\_Loss} = \Delta f_{pES} = 18.129 \text{ ksi}$$

**b. Time-Dependent Losses, Longterm\_Loss (AASHTO 5.9.5.2)**

Long-term loss is loss due to creep and shrinkage of concrete and relaxation of steel **Shrinkage Losses**,  $\Delta f_{ES}$  (AASHTO.5.9.5.4.2)

$$\Delta f_{pR} = 2.4 \text{ ksi}$$

Average annual ambient relative humidity is given as

$$H = 80\%$$

Then

$$\gamma_h = 1.7 - 1.0H = 1.7 - 1.0(0.8) = 0.9$$

$$\gamma_{st} = \frac{5}{(1 + f'_{ci\_BT} \text{ in.}^2/\text{kip})} = \frac{5}{1 + 6} = 0.714$$

$$\begin{aligned} \Delta f_{pLT} &= 10 \left( \frac{f_{pi} A_{ps}}{A_g} \right) \gamma_h \gamma_{st} + 12 \gamma_h \gamma_{st} (\text{ksi}) + \Delta f_{pR} \quad (\text{AASHTO. 5.9.5.2.3a} - 1) \\ &= 10 \left( \frac{(202.5)(5.625)}{713} \right) (0.9)(0.714) + 12(0.9)(0.714) + 2.4 = 20.384 \text{ ksi} \end{aligned}$$

$$\text{Time\_Depend\_Loss} = \Delta f_{pLT} = 20.384 \text{ ksi}$$

$$\Delta_{pT} = \text{Inst\_Loss} + \text{Time\_depend\_Loss} = 18.1 + 20.4 = 38.5 \text{ ksi}$$

## 6. Check Girder Stresses at Transfer

### Initial Prestressing Force

$$f_{pi} = 0.75f_{pu} - \Delta f_{pES} = 0.75(270) - 18.1 = 184.371 \text{ ksi Effective stress at transfer:}$$

$$F_{pi} = f_{pi} A_{ps} = 184.371(5.625) = 1037 \text{ K}$$

a. Tensile stress at the top of girder at midspan:

$$M_{girder} = M_{DC1\_NC} = 928.385 \text{ kip} \cdot \text{ft} \quad \text{Moment of girder}$$

$$\begin{aligned} f_{ti} &= \frac{-F_i}{A_g} + \frac{F_i e_m}{S_{bg}} - \frac{M_{girder}}{S_{bg}} = \frac{-1037}{713} + \frac{1037(27.59)}{12715} - \frac{928.4}{12715} \\ &= -0.08 < f_{ti\_a} = 0.588 \text{ ksi} \Rightarrow \text{OK} \end{aligned}$$

where

$$e_m = 27.594 \text{ in.}$$

b. Compressive stress at the bottom of girder at midspan:

$$\begin{aligned} f_{bi} &= \frac{-F_i}{A_g} - \frac{F_i e_m}{S_{bg}} + \frac{M_{girder}}{S_{bg}} = \frac{-1037}{713} - \frac{1037(27.594)}{12,224} + \frac{928.4}{12,224} \\ &= -2.884 \text{ ksi} < f_{ci\_a} = -3.6 \text{ ksi} \Rightarrow \text{OK} \end{aligned}$$

Negative sign indicates compression.

c. Tensile stress at the top of girder at the end of the section. Moment due to self-weight is zero.

$$\begin{aligned} f_{ti} &= \frac{-F_i}{A_g} + \frac{F_i e_{end}}{S_{tg}} - \frac{0}{S_{tg}} = \frac{-1037}{713} + \frac{1037(14.17)}{12715} = -0.299 \text{ ksi} < f_{ti\_a} \\ &= 0.588 \text{ ksi} \Rightarrow \text{OK} \end{aligned}$$

- d. Compressive stress at the bottom of girder at the end of the section. Moment due to self-weight is zero.

$$f_{ti} = \frac{-F_i}{A_g} - \frac{F_i e_{\text{end}}}{S_{tg}} - \frac{0}{S_{tg}} = \frac{-1037}{713} + \frac{1037(14.17)}{12715} = -2.61 \text{ ksi} > f_{ci\_a}$$

$$= -3.6 \text{ ksi} \Rightarrow \text{OK}$$

## 7. Check Girder Stresses after Total Losses

### Final Prestressing Force after total losses

$$f_{pf} = 0.75f_{pu} - 4f_{pT} = 0.75(270) - 38.5 = 167.5 \text{ ksi} \quad \text{Effective stress at transfer}$$

$$F_f = f_{pf} A_{ps} = 167.5(5.625) = 942 \text{ K}$$

- a. Compressive stress at the top of girder at midspan due to effective stress and permanent loads (Service I)

$$f_{tf} = \frac{-F_f}{A_g} + \frac{F_f e_m}{S_{tg}} - \frac{M_{DC1} + M_{DC2}}{S_{tg}} - \frac{M_{DW} + M_{LL}}{S_{ic}}$$

$$= \frac{-942}{713} + \frac{942(27.59)}{12,715} - \frac{2045.6 + 255.6}{12,715} - \frac{350 + 2389.7}{58,294} = -2.013 \text{ ksi} > f_{c1\_a}$$

$$= -3.6 \text{ ksi} \Rightarrow \text{OK}$$

- b. Tensile stress at the bottom of girder at midspan due to effective stress and permanent loads (Service III)

$$f_{bf} = \frac{-F_f}{A_g} - \frac{F_f e_m}{S_{bg}} + \frac{M_{DC1} + M_{DC2}}{S_{bg}} + \frac{M_{DW} + 0.8M_{LL}}{S_{bc}}$$

$$= \frac{-942}{713} - \frac{942(27.59)}{12,224} + \frac{2045.6 + 255.6}{12,224} + \frac{350 + 0.8(2389.7)}{17,407} = 0.37 \text{ ksi} < f_{tf\_a}$$

$$= 0.537 \text{ ksi} \Rightarrow \text{OK}$$

- c. Compressive stress at the top of deck due to added dead load and live load

$$f_{tc} = \frac{-(M_{DW} + M_{LL})}{S_{tc}} = \frac{-(350 + 2389.7)}{35,956} = -0.91 > f_{c\_deck\_a}$$

$$= -2.4 \text{ ksi} \Rightarrow \text{OK}$$

Therefore, thirty-eight-0.5-in.-diameter low-relaxation strands satisfy service limit state.

## STRENGTH LIMIT STATE—FLEXURE IN POSITIVE MOMENT

Maximum factored moment for strength I is

$$M_u = \text{Strength I} = 7583 \text{ kip} \cdot \text{ft}$$

1. Find stress in prestressing steel-bonded tendons:

$$f_{ps} = f_{pu} \left( 1 - k \frac{c}{d_p} \right)$$



where

$$k = 2 \left( 1.04 - \frac{f_{pv}}{f_{pu}} \right) = 2 \left( 1.04 - \frac{243}{270} \right) = 0.28$$

$A_{ps} = 5.625 \text{ in.}^2$  Area of prestressing strands

$A'_s = 0$  Area of compressive steel

$A_s = 0$  Area of reinforcing steel at the bottom of girder; assume fully prestressed

$f_{pu} = 270 \text{ ksi}$ ,  $f_y = 60 \text{ ksi}$   $f'_s = 60 \text{ ksi}$

$b = b_{\text{eff\_int}} = 8.5 \text{ ft}$  Width of compression face of member

$d_p = D_s - y_m = 67.474 \text{ in.}$  Distance from extreme fiber to cg of PS strands

$d_s = D_s - 3 \text{ in.} = 69 \text{ in.}$  Distance from extreme fiber to cg of mild reinforcement

$d'_s = 0 \text{ in.}$  Distance from extreme fiber to cg of compression reinforcement, assume no compression steel

$h_f = t_s = 8 \text{ in.}$  Depth of compression flange = thickness of deck

$\beta_1 = 0.85 - 0.05(f'_{c\_BT} - 4 \text{ ksi}) \frac{1}{\text{ksi}}$   
 $= 0.85 - 0.05(8 - 4) = 0.65$

Assume rectangular section behavior,  $b = b_w$ :

$$b_w = b = 102 \text{ in.}$$

$$c_{\text{rec}} = \frac{A_{ps}f_{pu} + A_s f_y - A'_s f'_s}{0.85f'_{c\_BT}\beta_1 b_w + kA_{ps}(f_{pu}/d_p)}$$

$$= \frac{(5.625)(270) + 0 + 0}{0.85(8)(0.65)(102) + 0.28(5.625)(270/67.47)} = 3.322 \text{ in.}$$

if  $(c_{\text{rec}} \leq h_f$ , “Assumption – correct”, “NG, try” T – Section – behavior”)

= “Assumption – correct”

$$C_T = \frac{A_{ps}f_{pu} + A_s f_y - A'_s f'_s - 0.85f'_{c\_BT}(b - b_w)h_f}{0.85f'_{c\_BT}\beta_1 b_w + kA_{ps}(f_{pu}/d_p)}$$

$$= 3.322 \text{ in.} \quad (\text{Assume T – section behavior})$$

Use

$$c = c_{\text{rec}} = 3.322 \text{ in.}$$

Therefore,

$$f_{ps} = f_{pu} \left( 1 - \frac{kc_{\text{rec}}}{d_p} \right) = 270 \left( 1 - \frac{0.28(3.322)}{67.47} \right) = 266.3 \text{ ksi}$$

## 2. Factored flexural resistance—flanged section

$$\phi_f = 1.0$$

For tension-controlled prestressed concrete section, AASHTO  
Table 5.5.4.2.2-1

$$a = \beta_1 c = (0.65)(3.322) = 2.159 \text{ in.}$$

$$\begin{aligned} M_n &= A_{ps}f_{ps} \left( d_p - \frac{1}{2}a \right) + A_s f_y \left( d_s - \frac{1}{2}a \right) - A'_s f'_s \left( d'_s - \frac{1}{2}a \right) \\ &\quad + 0.85f'_{c\_BT}(b - b_w)h_f \left( \frac{1}{2}a - \frac{1}{2}h_f \right) \\ &= (5.625)(266.3) \left( 67.47 - \frac{2.159}{2} \right) + 0 + 0 + 0 = 8287 \text{ kip} \cdot \text{ft} \end{aligned}$$

$$\phi M_n = \phi_f M_n = (1.0)(8287) = 8287 \text{ kip} \cdot \text{ft}$$

$$\text{Check\_flexure} = \text{if } (\phi M_n \geq M_u, \text{“OK”}, \text{“NG”}) = \text{“OK”}$$

### 3. Check maximum and minimum reinforcement

- a.** Maximum reinforcement (AASHTO 5.7.3.3.1): Provision deleted in 2005.
- b.** Minimum reinforcement (AASHTO 5.7.3.3.2): At any section of a flexural component, the amount of prestressed and non-prestressed tensile reinforcement shall be adequate to develop a factored flexural resistance,  $M_r$ , at least equal to the lesser of:

**i.**  $1.2M_{cr}$ :

$$M_{cr} = S_c(f_r + f_{cpe}) - M_{dnc} \left( \frac{S_c}{S_{nc}} - 1 \right) \geq S_c f_r$$

where

$$\begin{aligned} f_{cpe} &= \frac{-F_f}{A_g} - \frac{F_f e_m}{S_{bg}} \\ &= \frac{-942}{713} - \frac{942(27.59)}{12,224} \\ &= -3.488 \text{ ksi} \end{aligned}$$

Compressive stress in concrete due to effective prestress forces only at extreme fiber of section where tensile stress is caused by externally applied loads

$$f_r = 0.37 \sqrt{f'_{c\_BT}} \text{ ksi} = 1.047$$

Modulus of rupture, AASHTO 5.4.2.6

$$M_{dnc} = M_{DC1} = 2045.6 \text{ kip} \cdot \text{ft}$$

Total unfactored dead-load moment acting on the noncomposite section

$$S_c = S_{bc} = 17407 \text{ in.}^3$$

Section modulus for the extreme fiber of the composite section where tensile stress is caused by externally applied loads

$$S_{nc} = S_{bg} = 12224 \text{ in.}^3$$

Section modulus for the extreme fiber of the monolithic or noncomposite section where tensile stress is caused by externally applied loads

$$\begin{aligned} M_{cr} &= \max \left[ \left[ S_c (f_r + f_{cpe}) - M_{dnc} \left( \frac{S_c}{S_{nc}} - 1 \right) \right], S_c f_r \right] \\ &= \max \left[ \left[ (17,405)(1.047 - 3.498) - 2045.6(12) \left( \frac{17,407}{12,224} \right) - 1 \right], \right. \\ &\quad \left. (17,407)(1.047) \right] = 1518 \text{ kip} \cdot \text{ft} \end{aligned}$$

$$1.2M_{cr} = 1821.6 \text{ kip} \cdot \text{ft}$$

ii. 1.33 times the factored moment required moment demand:

$$1.33M_u = 10,085.8 \text{ kip} \cdot \text{ft}$$

$$M_r = \min(1.2M_{cr}, 1.33M_u) = \min(1821.6, 10085.8) = 1821.6 \text{ kip} \cdot \text{ft}$$

$$\text{if } (\phi M_n \geq M_r, \text{“OK”}, \text{“NG”}) = \text{“OK”} \sqrt{b^2 - 4ac}$$

Therefore, provided section with thirty-eight-0.5-in. prestressing stands satisfy strength limit state.

### SHEAR DESIGN

A sample calculation is shown at the critical point for shear where  $D_s/2 = 36$  in. from the face of support.

$$x = \frac{D_s}{2} = \frac{6}{2} = 3 \text{ ft}$$

#### 1. Shear Demands

Maximum shear due to dead load at the critical section is calculated below.

$$w_{DC} = w_{DC1\_int} + w_{DC2\_int} = 1.636 + 0.205 = 1.841 \text{ klf}$$

$$V_{DC} = \frac{w_{DC}(L-x)}{2} = \frac{1.841(100-3)}{2} = 89.3 \text{ K} \quad \text{Shear due to dead and added dead loads}$$

$$V_{DW} = \frac{w_{DW\_int}(L-x)}{2} = \frac{0.28(100-3)}{2} = 13.6 \text{ K} \quad \text{Shear due to future wearing surface and utilities}$$

The maximum shear due to live load including the effects of dynamic load allowance and load distribution factor is calculated below:

Maximum shear due to uniform lane load of 0.64 klf:

$$V_{\text{uniformLL}} = \left[ 0.64 \text{ klf} \left( \frac{L}{2} - x \right) \right] = 0.64 \left( \frac{100}{2} - 3 \right) = 30.1 \text{ K}$$

Maximum shear due to design truck of HL-93 without dynamic load allowance:

$$V_{\text{HL93}} = 16 \text{ K} \left[ 4.5 \left( 1 - \frac{x}{L} \right) - \frac{42 \text{ ft}}{L} \right] = 16 \left[ 4.5 \left( 1 - \frac{3}{100} \right) - \frac{42}{100} \right] = 63.1 \text{ K}$$

Maximum shear due to design tandem without dynamic load allowance:

$$V_{\text{Tandem}} = 50 \text{ K} \left( 1 - \frac{x}{L} - \frac{2 \text{ ft}}{L} \right) = 50 \left( 1 - \frac{3}{100} - \frac{2}{100} \right) = 47.5 \text{ K}$$

$$V_{\text{truck}} = \max(V_{\text{HL93}}, V_{\text{Tandem}}) = \max(63.1, 47.5) = 63.1 \text{ K}$$

Design truck governs the shear demand and the controlling maximum live-load shear and the factored shear are computed, respectively:

$$V_{LL} = DV_{\text{int}} [V_{\text{uniformLL}} + (1 + \text{IM})V_{\text{truck}}] = 0.884[30.1 + (1 + 0.33)(63.1)] = 100.8 \text{ K}$$

$$V_u = 1.25V_{DC} + 1.5V_{DW} + 1.75V_{LL} = 1.25(89.3) + 1.5(13.6) + 1.75(100.8) = 308.4 \text{ K}$$

$M_u$  corresponding to  $V_u$  at this section is calculated as below:

$$M_{DC} = \frac{w_{DC}x^2}{8} = \frac{1.841(3)^2}{8} = 2.071 \text{ kip} \cdot \text{ft} \quad M_{DW} = \frac{w_{DW\_int}x^2}{8} = \frac{0.28(3)^2}{8} = 0.315 \text{ kip} \cdot \text{ft}$$

Maximum moment due to uniform lane load of 0.64 klf:

$$M_{\text{uniformLL}} = \frac{(0.64 \text{ klf})x(L-x)}{2} = \frac{0.64(3)(100-3)}{2} = 93.1 \text{ kip} \cdot \text{ft}$$

Maximum moment due to design truck of HL-93 without dynamic load allowance:

$$M_{\text{HL93}} = 16 \text{ K} \left[ 4.5 \left( 1 - \frac{x}{L} \right) - \frac{42 \text{ ft}}{L} \right] = 16 \left[ 4.5 \left( 1 - \frac{3}{100} \right) - \frac{42}{100} \right] = 189.4 \text{ kip} \cdot \text{ft}$$

Maximum moment due to design tandem without dynamic load allowance:

$$M_{\text{Tandem}} = (50 \text{ K})x \left( 1 - \frac{x}{L} - \frac{2 \text{ ft}}{L} \right) = 50(3) \left( 1 - \frac{3}{100} - \frac{2}{100} \right) = 142.5 \text{ kip} \cdot \text{ft}$$

Controlling maximum live load moment:

$$M_{\text{Truck}} = \max(M_{\text{HL93}}, M_{\text{Tandem}}) = \max(189.4, 142.5) = 189.4 \text{ kip} \cdot \text{ft}$$

The maximum moment due to live load, including the effects of dynamic load allowance and load distribution factor is calculated below:

$$\begin{aligned} M_{\text{LL}} &= DM_{\text{int}} \{ M_{\text{uniformLL}} + [(1 + \text{IM})M_{\text{truck}}] \} = 0.845[93.1 + (1 + 0.33)189.4] \\ &= 291.6 \text{ kip} \cdot \text{ft} \end{aligned}$$

The factored maximum moment demands corresponding to the maximum shear demands:

$$\begin{aligned} M_u &= 1.25M_{DC} + 1.5M_{DW} + 1.75M_{\text{LL}} = 1.25(2.1) + 1.5(0.3) + 1.75(291.6) \\ &= 513.4 \text{ kip} \cdot \text{ft} \end{aligned}$$

## 2. Nominal Shear Resistance

The nominal shear resistance  $V_n$  shall be the lesser of:

$$V_n = V_c + V_s + V_p \quad (\text{AASHTO 5.8.3.3 - 1})$$

$$V_n = 0.25f'_{c\_BT}b_vd_v + V_p \quad (\text{AASHTO 5.8.3.3 - 2})$$

The shear resistance provided by concrete:

$$V_c = 0.0316\beta\sqrt{f'_{c\_BT}}b_vd_v \quad (\text{AASHTO 5.8.3.3 - 3})$$

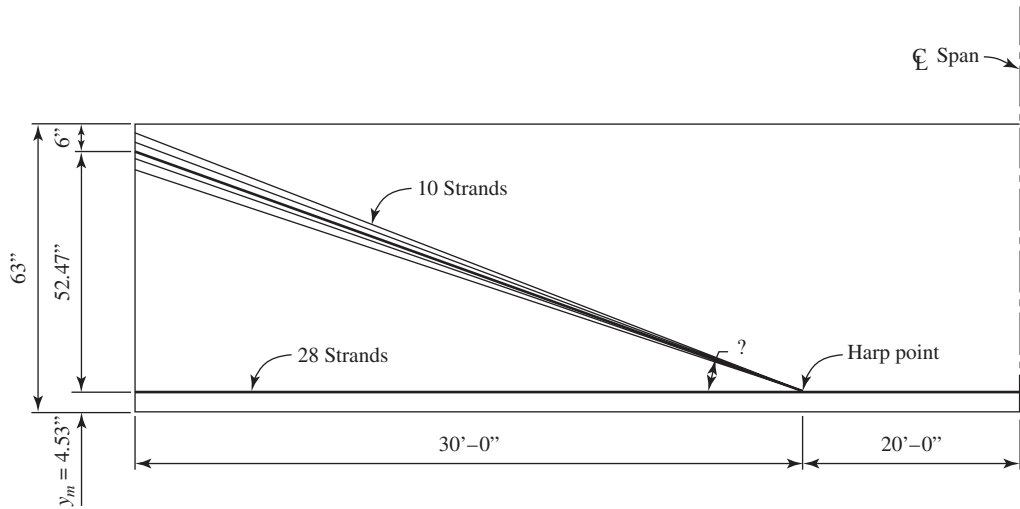
The shear resistance provided by transverse reinforcement:

$$V_s = \frac{A_v f_y d_v (\cot \theta + \cot \alpha) \sin \alpha}{s}$$

where

$b_v = 6.5 \text{ in.}$  Minimum web width, measured parallel to the neutral axis, between the resultants of the tensile and compressive forces due to flexure

$L_{cr} = x = 36 \text{ in.}$  Critical section for shear design



**Figure 22.16** Prestressing strand profile.

$h = D_s = 72$  in. Depth of composite section

$y_{cr} = 11.25$  in. From Figure 22.16,  $e_0$  is calculated to be 11.25 in at 36" from the face of support.

$$d_e = h - y_{cr} = 72 - 11.25 = 60.75$$

$$d_v = d_e - \frac{a}{2} = 60.75 - \frac{2.159}{2} = 59.67 \text{ in.}$$

and  $d_v$  need not to be smaller than  $0.9d_e$  or  $0.72h$ :

$$d_v \geq \max(0.9d_e, 0.72h)$$

$$d_{v\_min} = \max(0.9d_e, 0.72h) = \max[0.9(60.75), 0.72(72)] = 54.675 \text{ in.}$$

Therefore, use

$$d_v = 59.7 \text{ in.}$$

### 3. Prestress contribution to shear resistance

Vertical component of prestressing force is calculated as:

$$V_p = \frac{N_{ps\_harped}}{N_{ps}} F_f \sin \phi$$

where

$N_{ps\_harped} = 10$  Number of harped strands

$N_{ps} = 38$  Total number of strands

$$F_f = 942.174 \text{ K}$$

$$\psi = \tan^{-1} \left( \frac{52.47 - 6}{360} \right) = \frac{7.36\pi}{180}$$

Therefore,

$$V_p = \frac{N_{ps\_harped}}{N_{ps}} F_f \sin \psi = \frac{10}{38} (942.2) \sin(7.36) = 31.762 \text{ K}$$

#### 4. Shear stress on the concrete

$$v_u = \frac{V_u - \phi_v V_p}{\phi_v b_v d_v}$$

where,

$$\phi_v = 0.9$$

$$b_v = 6.5 \text{ in.}$$

$$V_u = 308.4 \text{ kip}$$

$$V_p = 31.762 \text{ kip}$$

$$v_u = \frac{V_u - \phi_v V_p}{\phi_v b_v d_v} = \frac{308.4 - 0.9(31.8)}{0.9(6.5)(59.67)} = 0.801 \text{ ksi} \quad \text{and} \quad \frac{v_u}{f'_{c\_BT}} = 0.1$$

Thus, maximum stirrups spacing,  $s < = 0.8d_v < = 24 \text{ in.}$

$$s_{\max} = \begin{cases} \min(0.8d_v, 24 \text{ in.}) - \text{if} \left( \frac{v_u}{f'_{c\_BT}} < 0.125 \right) \\ \min(0.8d_v, 12 \text{ in.}) - \text{otherwise} \end{cases} \quad s_{\max} = 24 \text{ in.}$$

For the calculation of shear strength of concrete and stirrups spacing  $\theta$  and  $\beta$  need to be determined. Two approaches will be shown next:

#### Approach 1 $\beta$ and $\theta$ -MCFT.

*First Iteration*

Assume  $\theta$  value

$$\theta_{\text{assume}} = 25^\circ$$

thus

$$\cot(\theta_{\text{assume}}) = 2.145$$

According to AASHTO, the effective value of  $f_{po}$  can be

$$f_{so} = 0.70f_{pu} = 0.7(270) = 189 \text{ ksi}$$

Assuming the section contains at least the minimum transverse reinforcement as specified in AASHTO 5.8.2.5:

$$\epsilon_x = \frac{(M_u/d_v) + 0.5(V_u - V_p)\cot(\theta_{\text{assume}}) - A_{ps}f_{so}}{2(E_s A_s + E_{ps} A_{ps})} \quad (\text{AASHTO } .5.8.3.4.2 - 1)$$

where

$$M_u = 513.4 \text{ kip} \cdot \text{ft}$$

$$V_u = 308.4 \text{ K}$$

$$V_p = 31.762 \text{ K}$$

$$N_u = 0$$

$$\begin{aligned}
 A_v &= 0.22 \text{ in.}^2 && \text{Area of shear reinforcement within a distance } s. \text{ Assume no. 3 bar (2 legs)} \\
 A_s &= 0 \\
 A_{ps} &= 5.625 \text{ in.}^2
 \end{aligned}$$

$$\begin{aligned}
 \epsilon_x &= \frac{(M_u/d_v) + 0.5(V_u - V_p)\cot(\theta_{\text{assume}}) - A_{ps}f_{so}}{2(E_sA_s + E_{ps}A_{ps})} \\
 &\times \frac{(513.4/59.67) + 0 + 0.5(308.4 - 31.8)(2.145) - 5.625(189)}{2(0 + 28500(5.625))} \\
 &= -2.069 \times 10^{-3} \\
 1000\epsilon_x &= -2.069
 \end{aligned}$$

Since  $\epsilon_x$  is negative, it shall be computed from Eq. 22.17:

$$\epsilon_x = \frac{M_u/d_v + 0.5N_u + 0.5(V_u - V_p)\cot(\theta_{\text{assume}}) - A_{ps} \cdot f_{ps}}{2(E_cA_c + E_sA_s + E_{ps}A_{ps})}$$

where

$$\begin{aligned}
 A_c &= A_g = 713 \text{ in.}^2 \\
 E_c &= E_{c_{\text{girder}}} = 5.422 \times 10^3 \\
 \epsilon_x &= \frac{(M_u/d_v) + 0.5N_u + 0.5(V_u - V_p)\cot(\theta_{\text{assume}}) - A_{ps}f_{so}}{2(E_cA_c + E_sA_s + E_{ps}A_{ps})} \\
 &= \frac{(513.4/59.67) + 0 + 0.5(308.4 - 31.8)(2.145) - 5.625(189)}{2[(5422)(713) + 0 + (28500)(5.625)]} \\
 &= -0.082 \times 10^{-3} \\
 1000\epsilon_x &= -0.082
 \end{aligned}$$

From Table AASHTO 5.8.3.4.2-1 reproduced in Table 2.15:

$$\theta = 20.4^\circ \quad \beta = 4.75$$

Since  $\theta$  is different from  $\theta_{\text{assumed}}$ , a second iteration is needed.

*Second Iteration*

Assume  $\theta$  value:

$$\theta_{\text{assume}} = 20.4^\circ$$

thus,

$$\begin{aligned}
 \cot(\theta_{\text{assume}}) &= 2.689 \\
 \epsilon_x &= \frac{(M_u/d_v) + 0.5N_u + 0.5(V_u - V_p)\cot(\theta_{\text{assume}}) - A_{ps}f_{so}}{2(E_cA_c + E_sA_s + E_{ps}A_{ps})} \\
 &= \frac{(513.4/59.67) + 0 + 0.5(308.4 - 31.8)(2.689) - 5.625(189)}{2[(5422)(713) + 0 + (28500)(5.625)]} \\
 &= -0.073 \times 10^{-3} \Rightarrow 1000\epsilon_x = -0.073
 \end{aligned}$$

From Table AASHTO 5.8.3.4.2-1 reproduced in Table 22.15, the  $\theta$  value converged with assumed value. Therefore, use

$$\theta = 20.4^\circ \quad \beta = 4.75$$

$$\begin{aligned} V_c &= 0.0316\beta \sqrt{\frac{f'_{c\_BT} \text{ ksi}}{\text{in.}^2}} b_v d_v && \text{Shear strength provided by concrete} \\ &= 0.0316(4.75) \sqrt{8} = 164.7 \text{ K} && \text{(AASHTO 5.8.3.3-3)} \end{aligned}$$

Minimum strength needs to be provided by stirrups:

$$V_s = \left( \frac{V_u}{\phi_v} - V_c - V_p \right) = \left( \frac{308.4}{0.9} - 164.7 - 31.8 \right) = 146.109 \text{ K}$$

Using no. 3 stirrups with  $A_v = 0.22 \text{ in.}^2$ :

$$s = \frac{A_v f_y d_v}{V_s} \cot \theta = \frac{(0.22)(60)(59.67)}{146.1} (2.689) = 14.503 \text{ in.}$$

Therefore, provide no. 3 U-shaped stirrups at a spacing of 14 in. at this section. Calculations at other sections are similar and should be performed to optimize design.

### Approach 2 $\beta$ and $\theta$ -Simplified MCFT.

Calculating  $\beta$  and  $\theta$  using simplified MCFT:

As calculated before, at critical section:

$$V_u = 1.25V_{DC} + 1.5V_{DW} + 1.75V_{LL} = 1.25(89.3) + 1.5(13.6) + 1.75(100.8) = 308.4 \text{ kip}$$

$$M_u = 1.25M_{DC} + 1.5M_{DW} + 1.75M_{LL} = 1.25(2.1) + 1.5(0.3) + 1.75(291.6) = 513.4 \text{ kip} \cdot \text{ft}$$

$$V_p = 31.762 \text{ kips} - 5.625(189)$$

$$d_v = 59.7 \text{ in.}$$

$$b_v = 6.5 \text{ in.}$$

$$h = D_s = 72 \text{ in.}$$

$$\begin{aligned} \epsilon_s &= \frac{\left( \frac{|M_u|}{d_v} + 0.5N_u + |V_u - V_p| - A_{ps}f_{po} \right)}{(E_s A_s + E_p A_{ps})} = \frac{\frac{513.4}{59.7} + |308.4 - 31.762| - 5.625(189)}{[(5422)(713) + (28500)(5.625)]} \\ &= -1.93 \times 10^{-4} \end{aligned}$$

Since  $\epsilon_s$  is negative, two approaches can be used:

a. Calculating  $\epsilon_s$  using Eq. (22.22):

$$\begin{aligned} \epsilon_s &= \frac{\left( \frac{|M_u|}{d_v} + 0.5N_u + |V_u - V_p| - A_{ps}f_{po} \right)}{(E_c A_{cf} + E_s A_s + E_p A_{ps})} \\ &= \frac{\frac{513.4}{59.7} + |308.4 - 31.762| - 5.625(189)}{[(5422)(234) + 0 + (28500)(5.625)]} \end{aligned}$$



$$= -5.44 \times 10^{-4} < -0.0004 \rightarrow \text{NOT OK} \rightarrow \epsilon_s = -0.0004$$

where

$$A_{cf} = b_v \times \frac{h}{2} = 6.5 \times \frac{72}{2} = 234 \text{ in.}^2$$

$$\beta = \frac{4.8}{1 + 750\epsilon_s} = \frac{4.8}{1 - 750 \times 4 \times 10^{-4}} = 6.86$$

$$\theta = 29 + 3500\epsilon_s = 29 - 0.0004 \times 3500 = 27.6^\circ \rightarrow \cot \theta = 1.91$$

$$V_c = 0.0316\beta\sqrt{f'_c}b_vd_v = 0.0316(6.86)\sqrt{8}(6.5)(59.7) = 238 \text{ kip}$$

$$V_s = \left( \frac{V_u}{\phi_v} - V_c - V_p \right) = \left( \frac{308.4}{0.9} - 238 - 31.762 \right) = 72.9 \text{ kip}$$

Using no. 3 stirrups with  $A_v = 0.22 \text{ in.}^2$

$$s = \frac{A_v f_y d_v}{V_s} \cot \theta = \frac{(0.22)(60)(59.67)}{72.9} (1.91) = 20.6 \text{ in.}$$

Therefore, provide no. 3 U-shaped stirrups at a spacing of 20 in. at this section. Calculations at other sections are similar and should be performed to optimize design.

**b.** Assuming  $\epsilon_s = 0$ :

$$\beta = \frac{4.8}{1 + 750\epsilon_s} = \frac{4.8}{1 + 0} = 4.8$$

$$\theta = 29 + 3500\epsilon_s = 29^\circ \rightarrow \cot \theta = 1.8$$

$$V_c = 0.0316\beta\sqrt{f'_c}b_vd_v = 0.0316(4.8)\sqrt{8}(6.5)(59.7) = 166.5 \text{ kip}$$

$$V_s = \left( \frac{V_u}{\phi_v} - V_c - V_p \right) = \left( \frac{308.4}{0.9} - 166.5 - 31.762 \right) = 144.4 \text{ kip}$$

Using #3 stirrups with  $A_v = 0.22 \text{ in.}^2$ .

$$s = \frac{A_v f_y d_v}{V_s} \cot \theta = \frac{(0.22)(60)(59.67)}{144.4} (1.8) = 9.8 \text{ in.}$$

Therefore, provide no. 3 U-shaped stirrups at a spacing of 10 in. at this section. Calculations at other sections are similar and should be performed to optimize design.

The following table is provided to show a comparison between the MCFT approaches, the simplified MCFT with calculated  $\epsilon_s$  value according to Eq. (22.22) and with  $\epsilon_s$  assumed to be zero.

---

**Summary of Shear Design with Three Different Approaches**


---

Calculated Parameter	Modified		
	Compression Field Theory (MCFT)	Simplified MCFT with Calculated Negative $\epsilon_s$	Simplified MCFT with $\epsilon_s = 0$
Cot $\theta$	2.689	1.91	1.8
$\beta$	4.75	6.8	4.8
$V_c$ (kips)	164.7	238	166.5
$V_s$ (kips)	146.1	72.9	144.4
S (in.)	14	20	10

---

By comparing these three methods, it can be observed that the simplified MCFT, when  $\epsilon_s$  is zero gives the most conservative stirrups spacing.

**ANCHORAGE ZONE DESIGN (AASHTO 5.10.10)**
**Factored Bursting Resistance (AASHTO. 5.10.10.1)**

The bursting resistance of the pretensioned anchorage zones provided by vertical reinforcement in the ends of pretensioned beams at the service limit state shall be taken as

$$P_r = f_s A_s$$

where

$f_s$  = stress in steel not exceeding 20 ksi

$A_s$  = total area of transverse reinforcement within  $h/4$  of end of beam

The resistance shall not be less than 4% of the prestressing force before transfer:

$$F_{\text{pbt}} = f_{\text{pbt}} A_{\text{ps}} = (218.7)(5.625) = 1230.2 \text{ K} \quad \text{Prestressing force before transfer}$$

$$P_r = 0.04 \cdot 2367890 - F_{\text{pbt}} = 0.04(1230.2) = 49.2 \text{ K} \quad \text{Minimum bursting resistance}$$

$$A_s = \left( \frac{P_r}{20 \text{ K}} \right) \text{in.}^2 = \frac{49.2}{20} = 2.46 \text{ in.}^2 \quad \text{Steel area of transverse reinforcement within } h/4 \text{ of end beam}$$

$$\text{within } \frac{h}{4} = 18 \text{ in.}$$

$$A_v = 0.4 \text{ in.}^2 \quad \text{Try \#4 stirrup}$$

$$N_s = \frac{A_s}{A_v} = \frac{2.46}{0.11} = 6.151 \quad \text{Number of stirrups required within distance of 18 in.}$$

**CONFINEMENT REINFORCEMENT (AASHTO 5.10.10.2)**
**Confinement Reinforcement (AASHTO 5.10.10.2)**

For a distance of 1.5 h from the end of the beam, reinforcement not less than no. 3 bars at 6 in. shall be placed to confine the prestressing steel in the bottom flange.

$$1.5 h = 108 \text{ in.}$$

**Use seven no. 4 stirrups within 18 in. to resist bursting force.**

**REINFORCEMENT DETAILS**

The details for the girder reinforcement is shown in Figs. 22.17, 22.18, and 22.19.

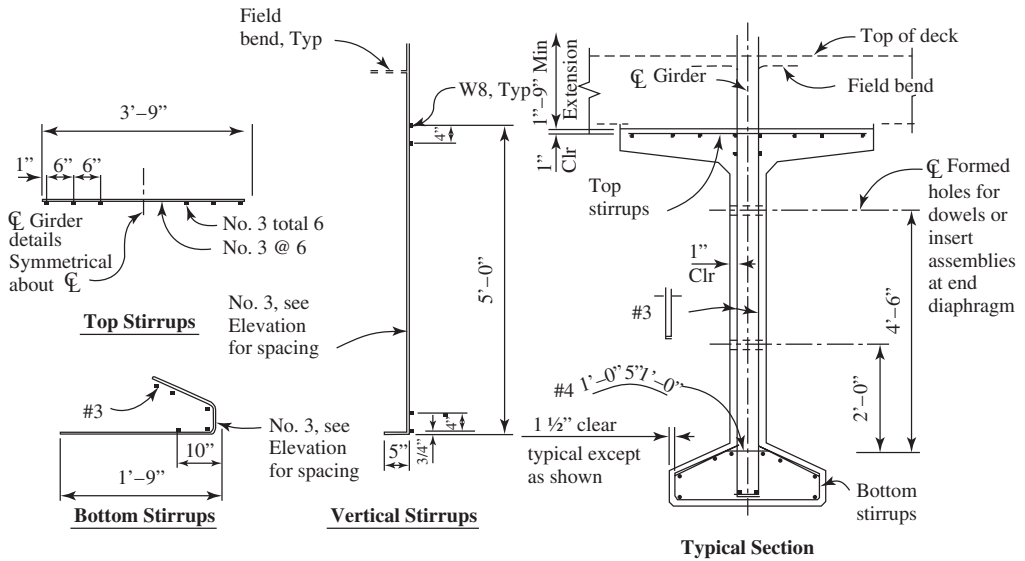


Figure 22.17 Girder reinforcement details.

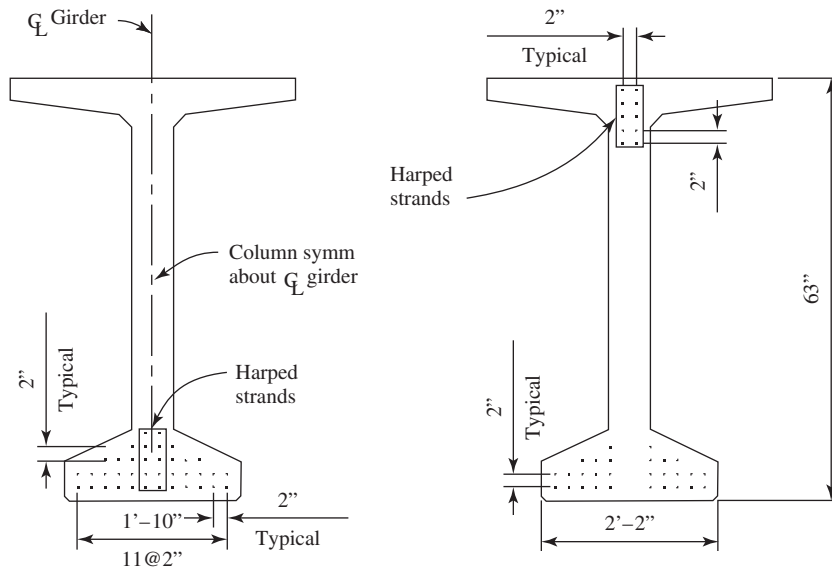


Figure 22.18 PS strand patterns.

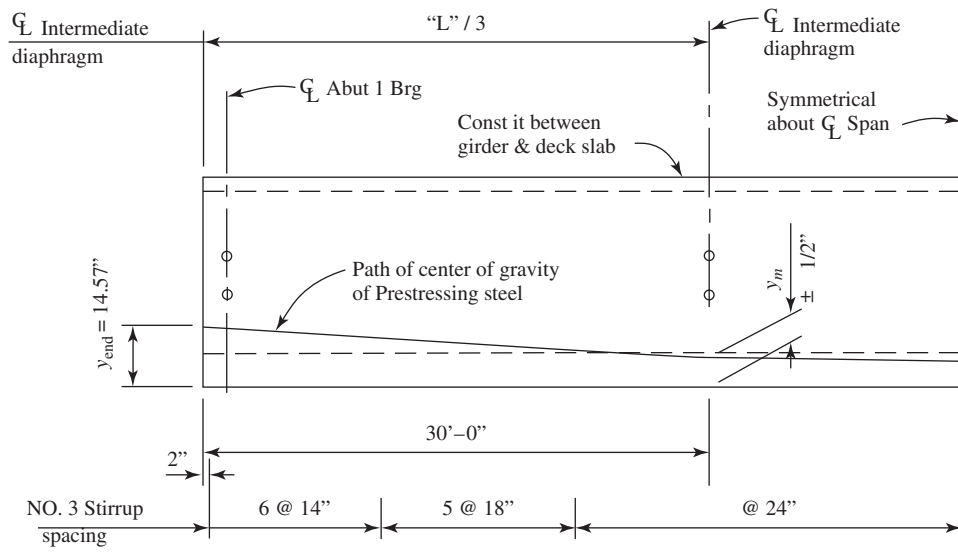


Figure 22.19 Girder longitudinal elevation.

## REFERENCES

1. American Association of State and Highway Transportation officials (AASHTO). *LRFD Bridge Design Specifications*, 7th ed. AASHTO, Washington, DC, 2014.
2. R. Barker, and J. Puckett. *Design of Highway Bridges: An LRFD Approach*, 2nd ed. Wiley, Hoboken, NJ, 2007.
3. N. Taly, *Design of Modern Highway Bridges*. McGraw-Hill, New York, 1998.
4. A. Naaman. *Prestressed Concrete Analysis and Design: Fundamentals*, 3rd ed. Techno Press 3000, Ann Arbor, MI, 2012.
5. E. Nawy. *Reinforced Concrete: A Fundamental Approach*, 6th ed. Prentice Hall, Upper Saddle River, NJ, 2009.
6. W. Wassef, C. Smith, C. Clancy, and M. Smith. "Comprehensive Design Example for Prestressed Concrete Girder Superstructure Bridge with Commentary." Task Order DTFH61-02-T-63032, November 2003.
7. M. P. Collins and D. Mitchell. "Shear and Torsion Design of Prestressed and Nonprestressed Concrete Beams," *PCI Journal* 25, No. 50 (1980): 32–100.
8. *PCI Design Handbook: Precast Prestressed Concrete*, 7th ed. Chicago, IL, 2010.
9. *PCI Precast Prestressed Concrete Bridge Design Manual*, 2nd ed. Chicago, IL with 5th Transmittal Letter. June 2009.
10. *Bridge Design Aids Manual*. Caltrans, Sacramento, CA, February 2008.
11. M. P. Collins, D. Mitchell, P. E. Adebear, and F. J. Vecchio. (1996). "A Shear Design Method." *ACI Structural Journal* 93, No. 1 (1996).

# REVIEW PROBLEMS ON CONCRETE BUILDING COMPONENTS

In order to achieve the desired strength of concrete in structural elements, it is particularly important to follow the proper procedure of determining member dimensions and the necessary reinforcement required. This chapter mainly focuses on the general process of designing various building components, such as slabs, beams, columns, and footings, with compliance to ACI Code 318-14. The first step is to calculate the required strength of each of these elements by multiplying the actual applied loads by load factors. These loads then develop external forces, such as bending moment, shear, axial forces, or torsion, depending on how these loads are being applied to the structure. Once the strength requirements are determined, the proper reinforcement, along with the appropriate dimensions of each element, can then be developed. The final design of structural elements must account for three main items: structural safety, deflection, and cracking conditions.

---

### Example 23.1

A simply supported beam has a 30 ft span and carries a service uniform dead load of 2 K/ft (including self-weight) and a uniform live load of 0.5 K/ft.

Given:  $b = 14$  in.,  $d = 26$  in.,  $f'_c = 5$  ksi,  $f_y = 60$  ksi.

- Design the section for flexural reinforcement.
- Design for shear reinforcement.
- Check for development length.

### Solution:

- Design the section for flexural reinforcement

Check for minimum thickness to satisfy the deflection criterion: (ACI Code, Section 24.2.3.1)

Minimum thickness for simply supported beams  $= L/16 = 30 \times 12/16 = 22.5$  in.  $< 29$  in. (OK)

Determine the design moment strength: (ACI Code, Section 5.3.1)

$$M_u = 1.2M_{DL} + 1.6M_{LL}$$

$$M_u = 1.2 \frac{w_{DL} \times L^2}{8} + 1.6 \frac{w_{LL} \times L^2}{8}$$

$$M_u = 1.2 \frac{2 \times 30^2}{8} + 1.6 \frac{0.5 \times 30^2}{8}$$

$$M_u = 360 \text{ K} \cdot \text{ft} = 4,320 \text{ K} \cdot \text{in.}$$

Check maximum moment: (ACI Code, Section 21.2.2)

Determine  $c_{\max}$  From Figure 23.1 in order to calculate  $A_{s, \max}$

$$\frac{0.003}{c_{\max}} = \frac{0.005}{d - c_{\max}}$$

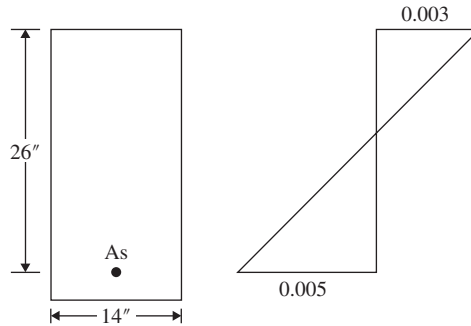
$$\frac{0.003}{c_{\max}} = \frac{0.005}{26 - c_{\max}}$$

$$c_{\max} = 9.75 \text{ in.}$$

$$a_{\max} = \beta_1 c_{\max} = 0.80 \times 9.75 = 7.80 \text{ in.}$$

$$A_{s, \max} = \frac{0.85 f'_c b a_{\max}}{f_y} = \frac{0.85(5)(14)(7.80)}{60} = 7.74 \text{ in.}^2$$

$$M_{u, \max} = \phi A_s f_y \left( d - \frac{a_{\max}}{2} \right) = (0.9)(7.74)(60) \left( 26 - \frac{7.80}{2} \right) = 9231 \text{ K} \cdot \text{in.} = 769 \text{ K} \cdot \text{ft}$$



**Figure 23.1** Strain diagram for the cross section.

Since  $M_u \leq M_{u, \max}$ , design as *single Reinforced Beam*

Find the required area of steel:

$$M_u = \phi A_s f_y \left( d - \frac{a}{2} \right), \text{ where } a = \frac{A_s f_y}{0.85 f'_c b}$$

$$M_u = \phi A_s f_y \left( d - \frac{A_s f_y}{1.75 f'_c b} \right)$$

$$4320 = (0.9) A_s (60) \left( 26 - \frac{A_s (60)}{1.75(5)(14)} \right)$$

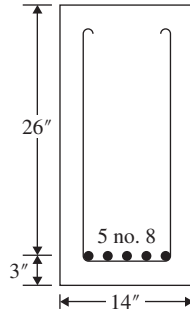
$$A_s = 3.28 \text{ in.}^2, \text{ use 5 no. 8 bars } (A_s = 3.93 \text{ in.}^2)$$

Check  $A_{s, \min}$ : (ACI Code, Section 9.6.1.2)

$$A_{s, \min} \text{ is the larger of } \begin{cases} \frac{3\sqrt{f'_c}}{f_y} b_w d = \frac{3\sqrt{5000}}{60000} (14)(26) = 1.29 \text{ in.}^2 \\ \frac{200 b_w d}{f_y} = \frac{200(14)(26)}{(60000)} = 1.21 \text{ in.}^2 \end{cases}$$

$$A_s > A_{s, \min} \quad \text{OK}$$

Beam details are shown in Figure 23.2.



**Figure 23.2** Detail of the beam.

**b. Design for shear reinforcement**

Calculate the factored shear from external loading:

$$w_u = 1.2w_{DL} + 1.6w_{LL} = 1.2(2) + 1.6(0.5) = 3.2 \text{ K/ft}$$

$$V_u = \frac{w_u L}{2} = \frac{(3.2)(30)}{2} = 48 \text{ K}$$

Calculate  $V_{ud}$  at distance  $d$  from face of support: (ACI Code, Section 9.4.3.2)

$$V_{ud} = V_u - w_u \left( \frac{d}{12} \right) = 48 - 3.2 \left( \frac{26}{12} \right) = 41.07 \text{ K}$$

Calculate  $\phi V_c$ ,  $\frac{\phi V_c}{2}$ ,  $V_{c1}$ ,  $V_{c2}$ : (ACI Code, Section 22.5.5.1)

$$\phi V_c = \phi \left( 2\lambda\sqrt{f'_c} \right) b_w d = 0.75(2)(1)\sqrt{5000}(14)(26) = 38.60 \text{ K}$$

$$\frac{\phi V_c}{2} = 19.30 \text{ K}$$

$$V_{c1} = 4\sqrt{f'_c} b_w d = 4\sqrt{5000}(14)(26) = 102.9 \text{ K}$$

$$V_{c2} = 8\sqrt{f'_c} b_w d = 8\sqrt{5000}(14)(26) = 205.9 \text{ K}$$

Calculate  $V_s$ : (ACI Code, Section 9.5.1.1)

$$V_s = \frac{V_{ud} - \phi V_c}{\phi} = \frac{41.07 - 38.60}{0.75} = 3.28 \text{ K}$$

Calculate maximum bar spacing for no. 3 stirrups: (ACI Code, Section 9.7.6.2.2)

Zone 1 (zone for  $V_u$  between  $\phi V_c$ , and  $\frac{\phi V_c}{2}$ )

$$s_1 = 24 \text{ in.}$$

$$s_2 = \frac{d}{2} = \frac{26}{2} = 13 \text{ in.} \rightarrow \text{Controls}$$

$$s_3 = \frac{A_v f_y}{50b_w} = \frac{(2 \times 0.11)(60000)}{(50)(14)} = 18.9 \text{ in.}$$

Zone 2 (zone for  $V_u > \phi V_c$ ) and  $V_s < V_{c1}$

$$s_1 = 24 \text{ in.}$$

$$s_2 = \frac{d}{2} = \frac{26}{2} = 13 \text{ in.} \rightarrow \text{Controls}$$

$$s_3 = \frac{A_v f_y}{50 b_w} = \frac{(2 \times 0.11)(60000)}{(50)(14)} = 18.9 \text{ in.}$$

$$s_4 = \frac{A_v f_y d}{V_s} = \frac{(2 \times 0.11)(60)(26)}{(3.28)} = 104.7 \text{ in.}$$

Using similar triangles from Figures 23.3

$$\frac{48}{180} = \frac{19.30}{x_1}$$

$$x_1 = 72.40 \text{ in.}$$

$$\frac{48}{180} = \frac{38.60}{x_2 + 72.40}$$

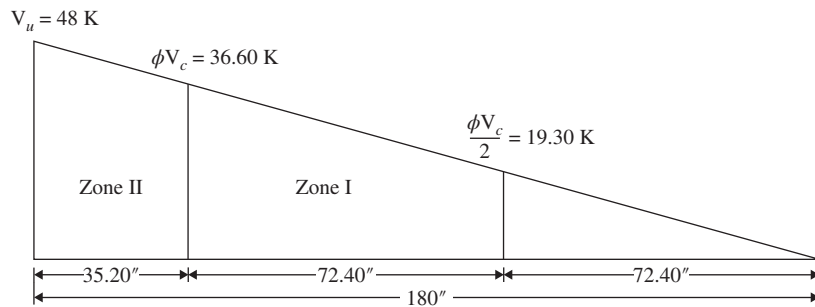
$$x_2 = 72.40 \text{ in.}$$

$$x_3 = 180 - 72.40 - 72.40 = 35.20 \text{ in.}$$

First stirrup at face of support

Second stirrup at  $s/2 = 13/2 = 6.5 \text{ in.}$

8 stirrups at 13 in.  $\rightarrow$  110.5 in.



**Figure 23.3** Shear reinforcement distribution diagram from the face to midspan of beam.

**c.** Check development length

Calculate the development length for tension bar  $l_d$ .

Check if conditions for spacing and cover are met to select an equation: (ACI Code, Section 25.4.2.2)

$$d_b = 1 \text{ in.}$$

$$\text{clear cover} = 2.5 \text{ in.} > d_b$$

$$\text{clear spacing} = \frac{14 - 6}{4} - 1 = 1 \text{ in.} \geq d_b$$



Conditions are met. Use  $l_d = \frac{\Psi_t \Psi_e f_y}{20\lambda \sqrt{f'_c}} d_b$

Determine the multiplication factors: (ACI Code, Section 25.4.2.4)

$$\Psi_t = 1.0 \text{ (bottom bars)}$$

$$\Psi_e = 1.0 \text{ (no coating)}$$

$$\Psi_t \Psi_e < 1.7 \text{ OK}$$

$$\lambda = 1.0 \text{ (normal-weight concrete)}$$

$$\sqrt{f'_c} = \sqrt{5000} = 70.7 \text{ psi} < 100 \text{ psi}$$

Calculate  $l_d$  (ACI Code, Section 25.4.2.2)

$$l_d = \frac{\Psi_t \Psi_e f_y}{20\lambda \sqrt{f'_c}} d_b = \frac{(1)(1)(60,000)}{20(1)\sqrt{5000}} (1) = 42.4 \text{ in.} = 43 \text{ in.} \geq 12 \text{ in.}$$

### Example 23.2

A series of reinforced concrete beams spaced at 8' 10'' on center is shown in Figure 23.4. The beams have a 15 ft span and support a 5 in. thick reinforced concrete slab.

Given: service dead load = 2 K/ft, service live load = 0.5 K/ft,  $b = 10 \text{ in.}$ ,  $d = 18 \text{ in.}$ ,  $f'_c = 3 \text{ ksi}$ ,  $f_y = 60 \text{ ksi}$ .

- Design the middle beam section for flexural reinforcement.
- Design middle beam section for shear reinforcement.
- Check for development length.

### Solution:

- Design the section for flexural reinforcement

Check for minimum thickness to satisfy the deflection criterion: (ACI Code, Section 24.2.3.1)

Minimum thickness for simply supported beams  $= L/16 = (15 \times 12)/16 = 11.25 \text{ in.} < 18 \text{ in.}$  (OK)

Calculate effective width of the flange  $b_e$ : (ACI Code, Section 6.3.2.1)

$$b_e = \frac{L}{4} = \frac{15 \times 12}{4} = 45 \text{ in.}$$

$$b_e = 16h_f + b_w = 16(5) + 10 = 90 \text{ in.}$$

$$b_e = l_n + b_w = 106 \text{ in.}$$

Choose smallest:  $b_e = 45 \text{ in.}$

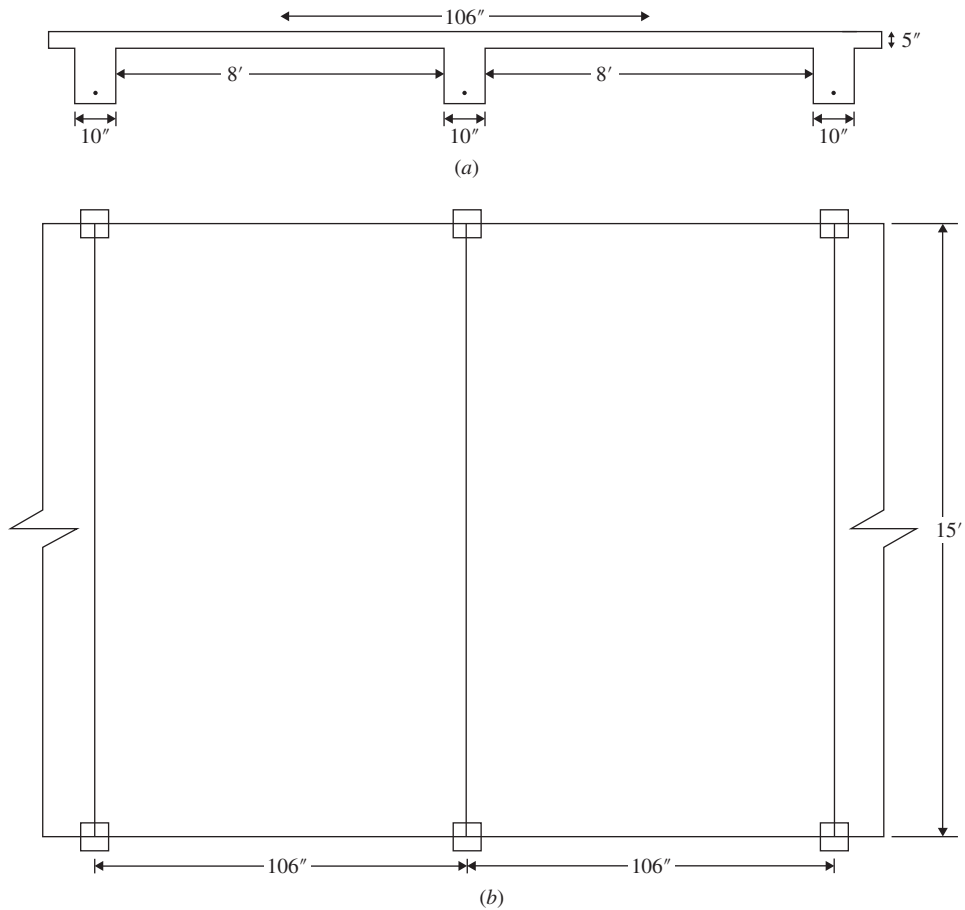
Determine the design moment strength: (ACI Code, Section 5.3.1)

$$M_u = 1.2M_{DL} + 1.6M_{LL}$$

$$M_u = 1.2 \frac{w_{DL} \times L^2}{8} + 1.6 \frac{w_{LL} \times L^2}{8}$$

$$M_u = 1.2 \frac{2115^2}{8} + 1.6 \frac{0.5615^2}{8}$$

$$M_u = 90 \text{ K} \cdot \text{ft} = 1080 \text{ K} \cdot \text{in.}$$



**Figure 23.4** Series of simply supported beams.

Check for the position of the neutral axis:

$$M_{uf} = \phi A_{sf} f_y \left( d - \frac{h_f}{2} \right), \text{ where } A_{sf} = \frac{0.85 f'_c h_f b}{f_y}$$

$$M_{uf} = \phi 0.85 f'_c h_f b_e \left( d - \frac{h_f}{2} \right) = 0.9(0.85)(3)(5)(45) \left( d - \frac{5}{2} \right)$$

$$= 8004 \text{ K} \cdot \text{in.} = 667 \text{ K} \cdot \text{ft} > M_u = 90 \text{ K} \cdot \text{ft}$$

$\therefore$  the neutral axis lies within the flange, rec tan gular analysis.

Calculate the required  $A_s$

$$a = \frac{A_s f_y}{0.85 f'_c b_e} = \frac{(1.57)(60)}{(0.85)(3)(45)} = 0.82 \text{ in.} < 5 \text{ in.}$$

$$M_u = \phi A_s f_y \left( d - \frac{a}{2} \right), \text{ where } 0.85 f'_c a b_e = A_s f_y \rightarrow a = \frac{A_s f_y}{0.85 f'_c b_e}$$

$$M_u = \phi A_s f_y \left( d - \frac{A_s f_y}{2 * 0.85 f'_c b_e} \right)$$

$$1080 = (0.90) A_s (60) \left( 18 - \frac{A_s f_y}{1.7 (3) (45)} \right)$$

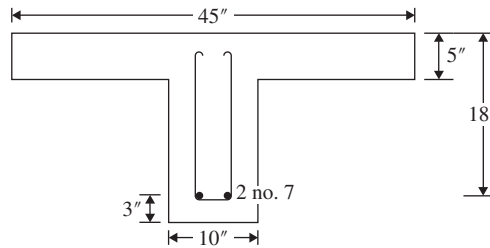
$$A_s = 1.13 \text{ in.}^2, \text{ use 2 no. 7 bars } (A_s = 1.20 \text{ in.}^2)$$

$$\text{Check that } \rho_w = \frac{A_s}{b_w d} = \frac{1.57}{(10)(18)} = 0.0087 \geq \rho_{\min} = 0.00333$$

$$\text{Check for } \phi : \epsilon_t : a = 0.82 \text{ in.}, c = \frac{0.82}{0.85} = 0.96 \text{ in.}, d_t = d = 22.5 \text{ in.}$$

$$\epsilon_t = \frac{0.003(d - c)}{c} = \frac{0.003(18 - 0.96)}{0.96} = 0.053 > 0.005, \phi = 0.9$$

Beam details are shown in Figure 23.5.



**Figure 23.5** Detail of the beam.

**b. Design for shear reinforcement**

Calculate the factored shear from external loading:

$$w_u = 1.2w_{DL} + 1.6w_{LL} = 1.2(2) + 1.6(0.5) = 3.2 \text{ K/ft}$$

$$V_u = \frac{w_u L}{2} = \frac{(3.2)(15)}{2} = 24 \text{ K}$$

Calculate  $V_u$  at distance  $d$  from face of support: (ACI Code, Section 9.4.3)

$$V_{ud} = V_u - w_u \left( \frac{d}{12} \right) = 24 - 3.2 \left( \frac{18}{12} \right) = 19.20 \text{ K}$$

Calculate  $\phi V_c$ ,  $\frac{\phi V_c}{2}$ ,  $V_{c1}$ ,  $V_{c2}$ : (ACI Code, Section 22.5.5.1)

$$\phi V_c = \phi \left( 2\lambda \sqrt{f'_c} \right) b_w d = 0.75(2)(1) \sqrt{3000} (10)(18) = 14.80 \text{ K}$$

$$\frac{\phi V_c}{2} = 7.40 \text{ K}$$

$$V_{c1} = 4 \sqrt{f'_c} b_w d = 4 \sqrt{3000} (10)(18) = 39.4 \text{ K}$$

$$V_{c2} = 8 \sqrt{f'_c} b_w d = 8 \sqrt{3000} (10)(18) = 78.8 \text{ K}$$

Calculate  $V_s$ : (ACI Code, Section 9.5.1.1)

$$V_s = \frac{V_{ud} - \phi V_c}{\phi} = \frac{19.20 - 14.79}{0.75} = 5.88 \text{ K}$$

Calculate maximum spacing using no. 3 stirrups: (ACI Code, Section 9.7.6.2)

Zone 1 (zone for  $V_u$  between  $\phi V_c$  and  $\frac{\phi V_c}{2}$ )

$$s_1 = 24 \text{ in.}$$

$$s_2 = \frac{d}{2} = \frac{18}{2} = 9 \text{ in.} \rightarrow \text{Controls}$$

$$s_3 = \frac{A_v f_y}{50 b_w} = \frac{(2 \times 0.11)(60000)}{(50)(10)} = 26.4 \text{ in.}$$

Zone 2 (zone for  $V_u > \phi V_c$ ) and  $V_s < V_{c1}$

$$s_1 = 24 \text{ in.}$$

$$s_2 = \frac{d}{2} = \frac{18}{2} = 9 \text{ in.} \rightarrow \text{Controls}$$

$$s_3 = \frac{A_v f_y}{50 b_w} = \frac{(2 \times 0.11)(60000)}{(50)(10)} = 26.4 \text{ in.}$$

$$s_4 = \frac{A_v f_y d}{V_s} = \frac{(2 \times 2.11)(60)(18)}{(2.83)} = 83.8 \text{ in.}$$

Using similar triangles from Figure 23.6

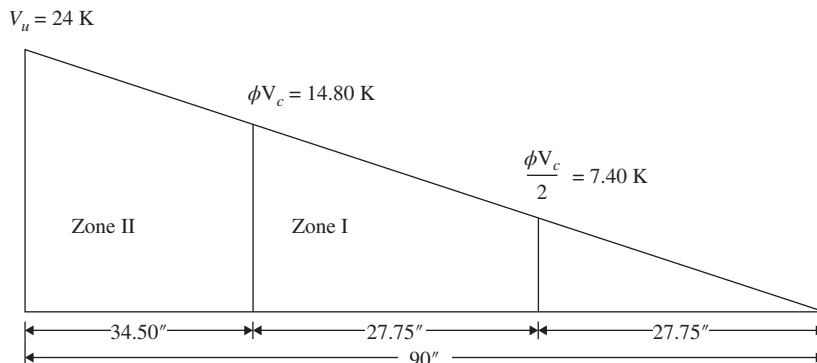
$$\frac{24}{90} = \frac{7.40}{x_1}$$

$$x_1 = 27.75 \text{ in.}$$

$$\frac{24}{90} = \frac{14.80}{x_2 + 27.75}$$

$$x_2 = 27.75 \text{ in.}$$

$$x_3 = 90 - 27.75 - 27.75 = 34.50 \text{ in.}$$



**Figure 23.6** Shear reinforcement distribution diagram from the face to midspan of beam.

First stirrup at face of support  
 Second stirrup at  $s/2 = 9/2 = 4.5$  in.  
 Seven stirrups at 9 in.  $\rightarrow$  67.5 in.

**c.** Check development length

Calculate the development length for tension bar  $l_d$   
 Check if conditions for spacing and cover are met to select an equation: (ACI Code, Section 25.4.2.2)

$$d_b = 1 \text{ in.}$$

$$\text{clear cover} = 3 \text{ in.} > d_b$$

$$\text{clear spacing} = \frac{10 - 7}{1} - 1 = 2 \text{ in.} > d_b$$

Conditions are met, use  $l_d = \frac{\Psi_t \Psi_e f_y}{20 \lambda \sqrt{f'_c}} d_b$

Determine the multiplication factors: (ACI Code, Section 25.4.2.4)

$$\Psi_t = 1.0 \text{ (bottom bars)}$$

$$\Psi_e = 1.0 \text{ (no coating)}$$

$$\Psi_t \Psi_e < 1.7 \text{ OK}$$

$$\lambda = 1.0 \text{ (normal - weight concrete)}$$

$$\sqrt{f'_c} = \sqrt{3000} = 54.8 \text{ psi} < 100 \text{ psi}$$

Calculate  $l_d$ : (ACI Code, Section 25.4.2.2)

$$l_d = \frac{\Psi_t \Psi_e f_y}{20 \lambda \sqrt{f'_c}} d_b = \frac{(1)(1)(60,000)}{20(1)\sqrt{3000}} (1) = 54.8 \text{ in.} = 55 \text{ in.} \geq 12 \text{ in.}$$

**Example 23.3**

A simply supported beam has a 25 ft span and carries a service uniform dead load of 3 K/ft (including self-weight) and a uniform live load of 1 K/ft.

Given:  $b = 12$  in.,  $d = 20$  in.,  $d' = 2.5$  in.,  $f'_c = 3$  ksi,  $f_y = 60$  ksi.

- Design the section for flexural reinforcement.
- Design for shear reinforcement.
- Check development length.

**Solution:**

- Design the section for flexural reinforcement

Check for minimum thickness to satisfy the deflection criterion: (ACI Code, Section 24.2.3.1)

$$\text{Minimum thickness for simply supported beam} = \frac{25}{16} = \frac{25 \times 12}{16} = 18.75 \text{ in.} \leq 25 \text{ in. (OK)}$$

Determine the design moment strength: (ACI Code, Section 5.3.1)

$$M_u = 1.2M_{DL} + 1.6M_{LL}$$

$$M_u = 1.2 \frac{w_{DL} \times L^2}{8} + 1.6 \frac{w_{LL} \times L^2}{8}$$

$$M_u = 1.2 \frac{3125^2}{8} + 1.6 \frac{1125^2}{8}$$

$$M_u = 406.25 \text{ K} \cdot \text{ft} = 4,875 \text{ K} \cdot \text{in.}$$

Check maximum moment: (ACI Code, Section 21.2.2)

Using similar triangles from Figure 23.7

$$\frac{0.003}{c_{\max}} = \frac{0.005}{d - c_{\max}}$$

$$\frac{0.003}{c_{\max}} = \frac{0.005}{20 - c_{\max}}$$

$$c_{\max} = 7.50 \text{ in.}$$

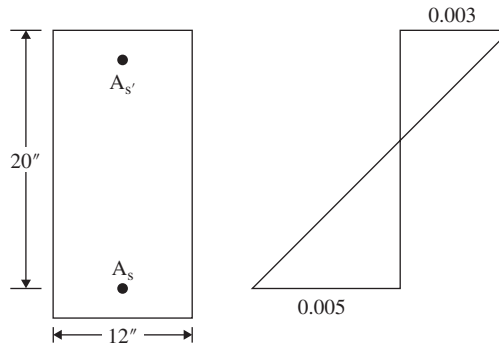
$$a_{\max} = \beta_1 c_{\max} = 0.85 \times 7.50 = 6.38 \text{ in.}$$

$$A_{s \max} = \frac{0.85 f'_c b a_{\max}}{f_y} = \frac{0.85(3)(12)(6.38)}{60} = 3.25 \text{ in.}^2$$

$$M_{u \max} = \phi A_{s \max} f_y \left( d - \frac{a_{\max}}{2} \right) = (0.9)(3.25)(60) \left( 20 - \frac{6.38}{2} \right)$$

$$= 2951.73 \text{ K} \cdot \text{in.} = 245.98 \text{ K} \cdot \text{ft}$$

$M_{u \max} < M_u$ , Compression steel is needed



**Figure 23.7** Strain diagram for the cross section.

Find the required area of steel:

$$M_{u1} = M_{u \max} = 245.98 \text{ K} \cdot \text{ft}$$

$$A_{s1} = A_{s \max} = 3.25 \text{ in.}^2$$

$$M_{u2} = M_u - M_{u1} = 406.25 - 245.98 = 160.27 \text{ K} \cdot \text{ft}$$

$$A_{s2} = \frac{M_{u2}}{\phi f_y (d - d')} = \frac{(160.27)(12)}{(0.9)(60)(20 - 2.5)} = 2.04 \text{ in.}^2$$

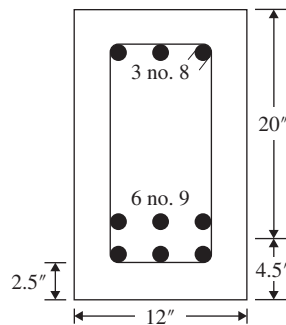
$$A_{s \text{ total}} = A_{s1} + A_{s2} = 3.25 + 2.04 = 5.29 \text{ in.}^2 \text{ (6 no. 9 bars)}$$

$$f'_s = 87000 \left( \frac{c_{\text{max}} - d'}{c_{\text{max}}} \right) = 87000 \left( \frac{7.5 - 2.5}{2.5} \right) = 58,000 \text{ psi} < f_y = 60,000 \text{ psi}$$

$$A'_s f'_s = A_{s2} f_y$$

$$A'_s = \frac{A_{s2} f_y}{f'_s} = \frac{(2.04)(60)}{58} = 2.11 \text{ in.}^2 \text{ (3 no. 8 bars, } A_s = 2.35 \text{ in.}^2)$$

Beam reinforcement details are shown in Figure 23.8.



**Figure 23.8** Cross sectional details.

**b. Design for shear reinforcement**

Calculate the factored shear at support from external loading:

$$w = 1.2w_{DL} + 1.6w_{LL} = 1.2(3) + 1.6(1) = 5.2 \text{ K/ft}$$

$$V_u = \frac{w_u L}{2} = \frac{(5.2)(25)}{2} = 65 \text{ K}$$

Calculate  $V_u$  at distance  $d$  from face of support: (ACI Code, Section 9.4.3)

$$V_{ud} = V_u - w_u \left( \frac{d}{12} \right) = 65 - 5.2 \left( \frac{20}{12} \right) = 56.33 \text{ K}$$

Calculate  $\phi V_c$ ,  $\frac{\phi V_c}{2}$ ,  $V_{c1}$ ,  $V_{c2}$ : (ACI Code, Section 22.5.5.1)

$$\phi V_c = \phi \left( 2\lambda \sqrt{f'_c} \right) b_w d = 0.75(2)(1)\sqrt{3000} (12)(20) = 19.72 \text{ K}$$

$$\frac{\phi V_c}{2} = 9.86 \text{ K}$$

$$V_{c1} = 4\sqrt{f'_c} b_w d = 4\sqrt{3000} (12)(20) = 52.58 \text{ K}$$

$$V_{c2} = 8\sqrt{f'_c} b_w d = 8\sqrt{3000} (12)(20) = 105.16 \text{ K}$$

Calculate  $V_s$ : (ACI Code, Section 9.5.1.1)

$$V_s = \frac{V_{ud} - \phi V_c}{\phi} = \frac{56.33 - 19.72}{0.75} = 48.82 \text{ K}$$

Calculate maximum spacing: (ACI Code, Section 9.7.6.2)

Zone 1 (zone for  $V_u$  between  $\phi V_c$ , and  $\frac{\phi V_c}{2}$ )

$$s_1 = 24 \text{ in.}$$

$$s_2 = \frac{d}{2} = \frac{20}{2} = 10 \text{ in.} \rightarrow \text{Controls}$$

$$s_3 = \frac{A_v f_y}{50 b_w} = \frac{(2 \times 0.11)(60000)}{(50)(12)} = 22 \text{ in.}$$

Zone 2 (zone for  $V_u > \phi V_c$ ) and  $V_s < V_{c1}$

$$s_1 = 24 \text{ in.}$$

$$s_2 = \frac{d}{2} = \frac{20}{2} = 10 \text{ in.}$$

$$s_3 = \frac{A_v f_y}{50 b_w} = \frac{(2 \times 0.11)(60000)}{(50)(12)} = 22 \text{ in.}$$

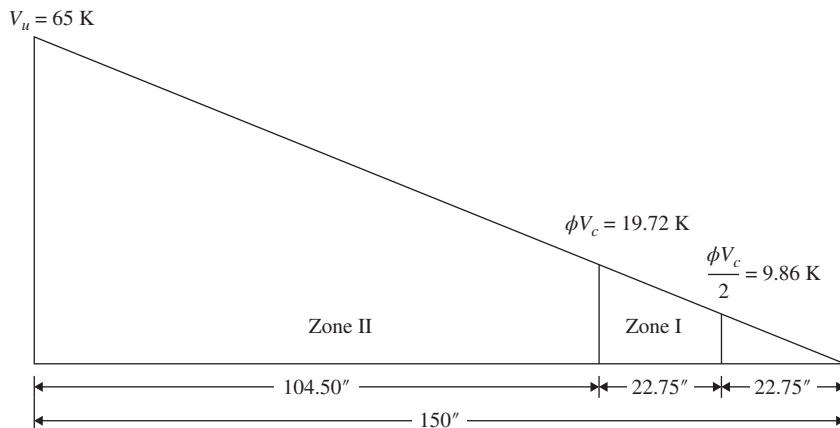
$$s_4 = \frac{A_v f_y d}{V_s} = \frac{(2 \times 0.11)(60)(20)}{(48.82)} = 5.4 \text{ in.} \rightarrow \text{Use 5.4 in. Controls}$$

Using similar triangles from Figure 23.9

$$\frac{65}{150} = \frac{9.86}{x_1}$$

$$x_1 = 22.75 \text{ in.}$$

$$\frac{65}{150} = \frac{19.72}{x_2 + 22.75}$$



**Figure 23.9** Shear reinforcement distribution diagram from the face to midspan of beam.



$$x_2 = 22.75 \text{ in.}$$

$$x_3 = 150 - 22.75 - 22.75 = 104.50 \text{ in.}$$

- 1st stirrup at face of support
- 2nd stirrup at  $s/2 = 5/2 = 2.5 \text{ in.}$
- 21 stirrups at 5 in.  $\rightarrow 107.5 \text{ in.}$
- 2 stirrups at 10 in.  $\rightarrow 127.5 \text{ in.}$

**c. Check development length**

Calculate the development length in compression  $l_{dc}$  (ACI Code, Section 25.4.9)

$$l_{dc} = \text{largest of } \begin{cases} \frac{0.02f_y}{\lambda\sqrt{f'_c}}d_b = \frac{0.02(60,000)}{(1)\sqrt{3000}}(1) = 21.9 \text{ in.} = 22 \text{ in.} \\ (0.0003f_y)d_b = (0.0003 \times 60,000)(1) = 18 \text{ in.} \\ 8 \text{ in.} \end{cases}$$

Therefore  $l_{dc} = 22 \text{ in.}$

Calculate the development length for tension bar  $l_d$ .

Check if conditions for spacing and cover are met to select an equation. (ACI Code, Section 25.4.2.2)

$$d_b = 1 \text{ in.}$$

Since *clear cover* = 2.5 in.  $> d_b$

$$\text{and clear spacing} = \frac{12 - 6}{2} - 1.128 = 1.9 \text{ in.} \geq d_b$$

$$\text{then conditions are met to use } l_d = \frac{\Psi_t\Psi_e f_y}{20\lambda\sqrt{f'_c}}d_b$$

Determine the multiplication factors: (ACI Code, Section 25.4.2.4)

$$\Psi_t = 1.0 \text{ (bottom bars)}$$

$$\Psi_e = 1.0 \text{ (no coating)}$$

$$\Psi_t\Psi_e < 1.7 \text{ OK}$$

$$\lambda = 1.0 \text{ (normal - weight concrete)}$$

$$\sqrt{f'_c} = \sqrt{3000} = 54.8 \text{ psi} < 100 \text{ psi}$$

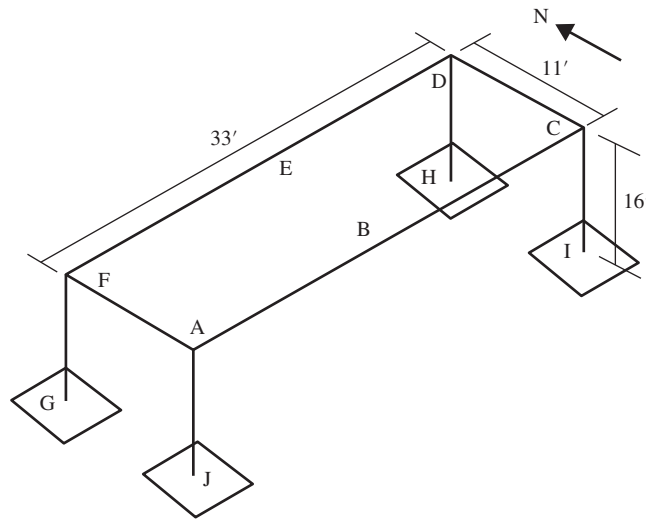
Calculate  $l_d$ : (ACI Code, Section 25.4.2.2)

$$l_d = \frac{\Psi_t\Psi_e f_y}{20\lambda\sqrt{f'_c}}d_b = \frac{(1)(1)(60,000)}{20(1)\sqrt{3000}}(1.128) = 61.8 \text{ in.} = 62 \text{ in.} \geq 12 \text{ in.}$$

**Example 23.4**

A simply supported one-story building frame is shown in Figure 23.10. The building is 16 ft high and has a 33 ft x 11 ft slab.

- a.** Design the slab.
- b.** Design the beam along points A and C.



**Figure 23.10** One story building.

- c. Design the column at point C.
- d. Design the footing at point C.

**Given:**

$DL = 45$  psf, self weight not included

$LL = 75$  psf

$f'_c = 4$  ksi

$f_y = 60$  ksi

Normal weight concrete

**Slab**

$M_u$  for a 1 ft width of slab = 3 K · ft

**For Beam AC (See Figure 2)**

$L = 33$  ft

$b_w = 12$  in.

$V_u = 21.84$  k

$M_u$  at A and C =  $-21.57$  K.ft

$M_u$  at B = 100.90 K.ft

**Column C**

$b \times h = 12$  in.  $\times$  12 in.

$L_c = 16$  ft

$M_u(N - S) = 2.98$  K.ft

$M_u(E - W) = 11.65$  K.ft

$P_u = 27.45$  K

**Footing at C**

Service  $DL = 30$  K

Service  $LL = 8$  K

Allowable soil pressure = 4 ksf

$$\gamma_{\text{soil}} = 130 \text{ pcf}$$

*Note:* All moments and shear values are calculated using ADAPT-BUILDER software.

**Solution:**

**a. Design the Slab**

1. Assume a slab thickness. For  $f_y = 60$  ksi, the minimum depth to control deflection is  $L/20 = 11(12)/20 = 6.6$  in. Assume a total depth of  $h = 7$  in. and assume  $d = 6$  in. (to be checked later).
2. Calculate  $A_s$ : For  $M_u = 3 \text{ K} \cdot \text{ft}$ ,  $b = 12$  in., and  $d = 6$  in.,  $R_u = \frac{M_u}{bd^2} = \frac{3(12,000)}{(12)(6)^2} = 83.33$  psi. From tables in Appendix A,  $\rho = 0.0023 < \rho_{\text{max}} = 0.01806$ ,  $\phi = 0.9$ .

$$\therefore A_s = \rho bd = 0.0023(12)(6) = 0.17 \text{ in.}^2$$

Choose no. 4 bars,  $A_b = 0.2 \text{ in.}^2$ , and  $S = \frac{12A_b}{A_s} = \frac{12(0.2)}{0.17} = 14.12$  in.

Check actual  $d = 7 - \frac{3}{4} - \frac{4}{16} = 6$  in. (acceptable)

Let  $S = 14$  in. and  $A_s = 0.17 \text{ in.}^2$

3. Check the moment capacity of the final section.

$$A_s = \frac{12}{14}(0.2) = 0.1714 \text{ in.}^2$$

$$a = \frac{A_s f_y}{0.85 f'_c b} = \frac{0.1714(60)}{(0.85)(4)(12)} = 0.2521 \text{ in.}$$

$$\phi M_n = \phi A_s f_y \left( d - \frac{a}{2} \right) = (0.9)(0.1714)(60) \left( 6 - \frac{0.2521}{2} \right) = 54.37 \text{ K} \cdot \text{in.}$$

$$= 4.53 \text{ K} \cdot \text{ft} > M_u = 3 \text{ K} \cdot \text{ft}$$

4. Check main reinforcement maximum spacing. (ACI Code, Section 7.7.2.3)

$$s = 3h = 3 * 7 = 21 \text{ in.}$$

$$s = 18 \text{ in.}$$

*Use no. 4 bars spaced at 14 in.*

5. Calculate the shrinkage reinforcement normal to the main steel.

For  $f_y = 60$  ksi,  $\rho_{\text{min}} = 0.0018$  (ACI Code, Section 7.6.1.1)

$$A_{sh} = \rho bh = 0.0018(12)(7) = 0.15 \text{ in.}^2$$

Choose no. 4 bars,  $A_b = 0.2 \text{ in.}^2$ , and  $S = \frac{12A_b}{A_s} = \frac{12(0.2)}{0.1512} = 15.9$  in.

Let  $S = 15$  in. and  $A_s = 0.15 \text{ in.}^2$

6. Check the shrinkage reinforcement maximum spacing (ACI Code, Section 7.7.6.2)

$$s = 5h = 5 * 7 = 35 \text{ in.}$$

$$s = 18 \text{ in.}$$

*Use no. 4 bars spaced at 15 in.*

**b. Design Beam AC**

The shear and bending moment diagram is shown in Figure 23.11

$$\text{Clear span} = L_n = L - 2 \left( \frac{\text{column width}}{2} \right) = 33 - 2 = 31 \text{ ft}$$

$$\text{Minimum thickness} = \frac{L}{16} = \frac{33 \times 32}{16} = 24.75 \text{ in.} = 25 \text{ in.}$$

$$d = h - \left( \text{clear cover} + \frac{1}{2}d_b \right) = 25 - 2 - 0.5 = 22.5 \text{ in.}$$

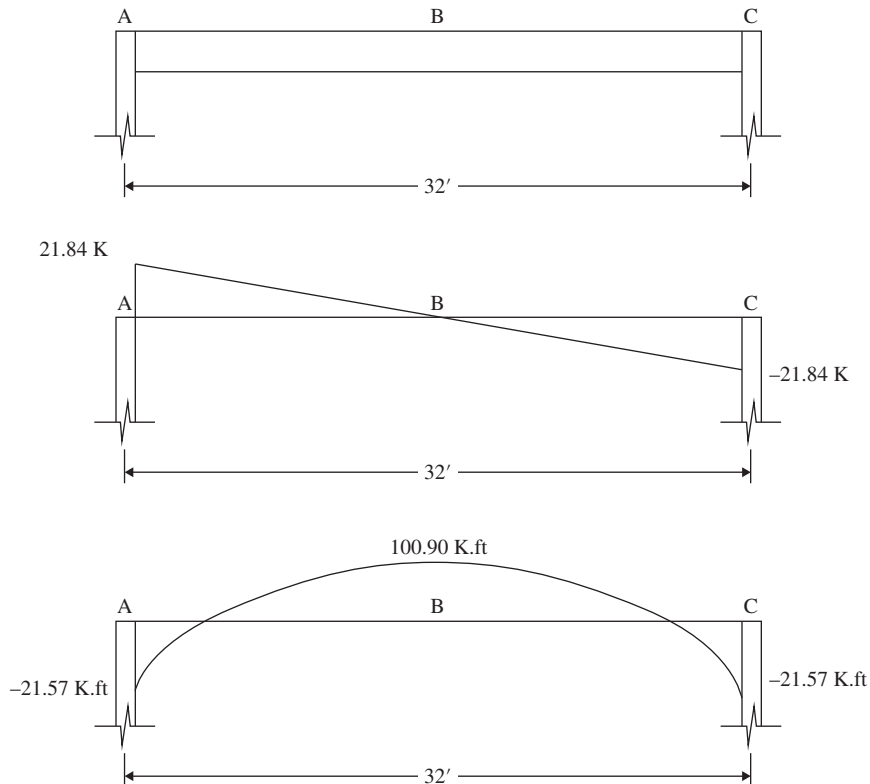
1. Determine the effective flange width  $b_e$ . The effective flange width is the smallest of:

$$b_e = b_w + \frac{L}{12} = 12 + \frac{33 * 12}{12} = 45 \text{ in.}$$

$$b_e = b_w + 6h_f = 12 + (6 * 7) = 54 \text{ in.}$$

$$b_e = b_w + \frac{L_n}{2} = 12 + \frac{31 * 12}{2} = 186 \text{ in.}$$

Therefore,  $b_e = 45 \text{ in.}$  (ACI Code, Section 6.3.2.1)



**Figure 23.11** Shear and moment diagram for beam AC.

2. Check for the position of the neutral axis.

$$M_{uf} = \phi A_{sf} f_y \left( d - \frac{h_f}{2} \right), \text{ where } A_{sf} = \frac{0.85 f'_c h_f b_e}{f_y}$$

$$\begin{aligned} M_{uf} &= \phi 0.85 f'_c h_f b_e \left( d - \frac{h_f}{2} \right) = 0.9(0.85)(4)(7)(45) \left( 22.5 - \frac{7}{2} \right) \\ &= 18314.10 \text{ K} \cdot \text{in.} = 1526.18 \text{ K} \cdot \text{ft} > M_u = 100.90 \text{ K} \cdot \text{ft} \end{aligned}$$

Therefore, the neutral axis lies within the flange; treat as a rectangular section for analysis

3. Calculate  $A_s$  at the center of the beam (in tension).

$$M_u = \phi A_s f_y \left( d - \frac{a}{2} \right), \text{ where } 0.85 f'_c a b_e = A_s f_y \rightarrow a = \frac{A_s f_y}{0.85 f'_c b_e}$$

$$M_u = \phi A_s f_y \left( d - \frac{A_s f_y}{2 \times 0.85 f'_c b_e} \right)$$

$$100.90(12) = 0.9 * A_s * 60 \left( 22.5 - \frac{A_s \times 60}{1.7 \times 4 \times 45} \right)$$

$$A_s = 1.01 \text{ in.}^2, \text{ Provide 2 no. 7 bars, } A_s = 1.20 \text{ in.}^2$$

4. Check the depth of the stress block. If the section behaves as a rectangular one, then the stress block lies within the flange.

$$a = \frac{A_s f_y}{0.85 f'_c b_e} = \frac{(1.57)(60)}{(0.85)(4)(45)} = 0.62 \text{ in.} < \text{slab thickness (7 in.)}$$

5. Check that:

$$\rho_w = \frac{A_s}{b_w d} = \frac{1.57}{(12)(22.5)} = 0.0058 \geq \rho_{\min} = 0.00333$$

6. Check  $\epsilon_t$ :  $a = 0.62 \text{ in.}$ ,  $c = \frac{0.62}{0.85} = 0.73 \text{ in.}$ ,  $d_t = d = 22.5 \text{ in.}$

$$\epsilon_t = \frac{0.003(d - c)}{c} = \frac{0.003(22.5 - 0.73)}{0.73} = 0.089 > 0.005, \phi = 0.9$$

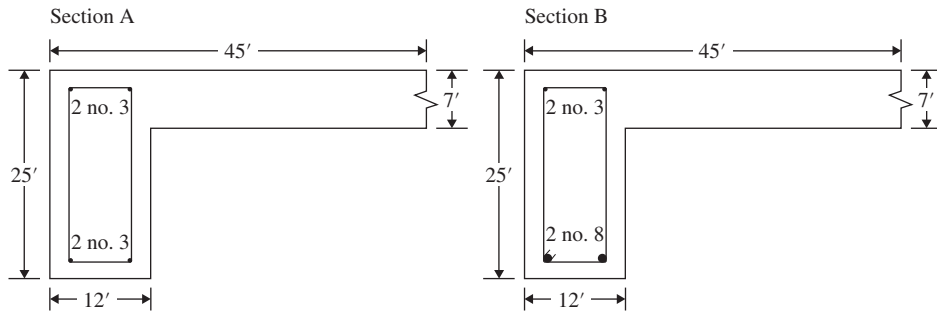
7. Calculate  $A_s$  at the face of the column (in compression).

$$M_u = \phi A_s f_y \left( d - \frac{a}{2} \right), \text{ where } 0.85 f'_c a b_w = A_s f_y \rightarrow a = \frac{A_s f_y}{0.85 f'_c b_w}$$

$$M_u = \phi A_s f_y \left( d - \frac{A_s f_y}{2 (0.85 f'_c b_w)} \right)$$

$$21.57(12) = 0.9(A_s)(60) \left( 22.5 - \frac{(A_s)(60)}{(1.7)(4)(12)} \right)$$

$$A_s = 0.21 \text{ in.}^2, \text{ Provide 2 no. 3 bars, } A_s = 0.22 \text{ in.}^2$$



**Figure 23.12** Detail of the beam at sections A and B.

8. Detail the sections (Figure 23.12).

9. Design for shear reinforcement.

Calculate the factored shear from external loading:

$$V_u = 21.84 \text{ K}$$

$$V_u = \frac{w_u L}{2} \rightarrow 21.84 = \frac{w_u (32)}{2}$$

$$w_u = 1.37 \text{ K/ft}$$

Calculate  $V_{ud}$  at distance  $d$  from face of support: (ACI Code, Section 9.4.3)

$$V_{ud} = V_u - w_u \left( \frac{d}{12} \right) = 21.84 - 1.37 \left( \frac{22.5}{12} \right) = 19.3 \text{ K}$$

Calculate  $\phi V_c$  and  $\frac{\phi V_c}{2}$ : (ACI Code, Section 22.5.5.1)

$$\phi V_c = \phi \left( 2\lambda \sqrt{f'_c} \right) b_w d = 0.75(2)(1)\sqrt{4000} (12)(22.5) = 25.61 \text{ K}$$

$$\frac{\phi V_c}{2} = 12.81 \text{ K}$$

Since  $\frac{\phi V_c}{2} \leq V_{ud} \leq \phi V_c$ , use minimum shear reinforcement

Calculate maximum spacing. (ACI Code, Section 9.7.6.2)

Select the smallest of:

$$s_1 = 24 \text{ in.}$$

$$s_2 = \frac{d}{2} = \frac{22.5}{2} = 11.25 \text{ in.}$$

$$s_3 = \frac{A_v f_y}{50 b_w} = \frac{(2 \times 2.11)(60000)}{(50)(12)} = 22 \text{ in.}$$

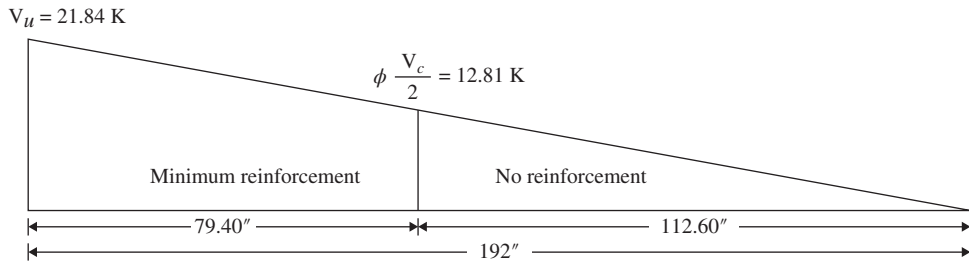
Therefore use = 11 in

Using similar triangles (Figure 23.13)

$$\frac{21.84}{192} = \frac{12.81}{x_1}$$

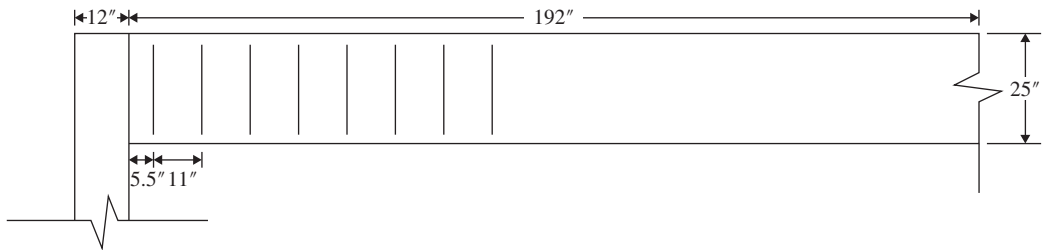
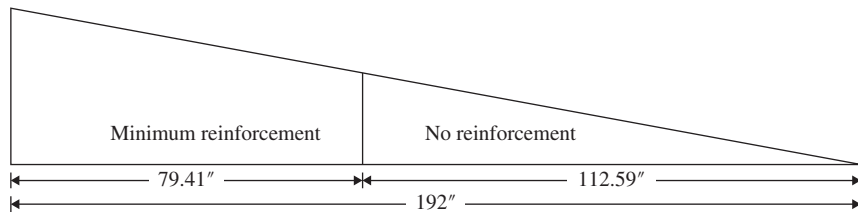
$$x_1 = 112.59 \text{ in.}$$

$$x_2 = 192 - 112.59 = 79.41 \text{ in.}$$



**Figure 23.13** Shear distribution diagram from the face to midspan of beam.

First no. 3 stirrup at  $s/2 = 11/2 = 5.5$  in.  
 Seven no. 3 stirrups at 11 in. = 77 in.  
 Total = 77 + 5.5 in. = 82.5 in.



**Figure 23.14** Bar distribution for shear reinforcement.

**10. Check development length**

The development length  $l_d$  for no. 3 tension bars at support A can be determined as follows:  
 Check if conditions for spacing and cover are met to select an equation. (ACI Code, Section 25.4.2.2)

$d_b = 0.375$  in.

Since clear cover = 2 in.  $> d_b$   
 and clear spacing =  $\frac{12 - 5}{1} - 0.375 = 6.625$  in.  $> 2d_b$

Condition met. Use  $l_d = \frac{f_y \Psi_t \Psi_e}{20 \lambda \sqrt{f'_c}} (d_b)$

Determine the multiplication factors. (ACI Code, Section 25.4.2.4)

$$\Psi_t = 1.3 \text{ (top bars)}$$

$$\Psi_e = 1.0 \text{ (no coating)}$$

$$\Psi_t \Psi_e < 1.7 \text{ OK}$$

$$\lambda = 1.0 \text{ (normal - weight concrete)}$$

$$\sqrt{f'_c} = \sqrt{4000} = 63.2 \text{ psi} < 100 \text{ psi ok}$$

Calculate  $l_d$  from: (ACI Code, Section 25.4.2.2)

$$l_d = \frac{f_y \Psi_t \Psi_e}{20 \lambda \sqrt{f'_c}} (d_b) = \frac{(60000)(1.3)(1)}{20(1)\sqrt{4000}} (0.375) = 23.12 \text{ in.} \geq 12 \text{ in.}$$

Check for the compression development length  $l_{dc}$ .

Compressive reinforcement at the face of the support (no. 3 bars) has the larger of the following development lengths, but cannot be less than 8 in.

$$l_{dc} = \frac{0.02 f_y}{\lambda \sqrt{f'_c}} (d_b) = \frac{(0.02)(60000)}{(1)\sqrt{4000}} (0.375) = 7.12 \text{ in.}$$

$$\text{Minimum } l_{dc} = 0.0003(d_b)(f_y) = 0.0003(0.375)(60000) = 6.75 \text{ in.}$$

Therefore,  $l_{dc} = 8 \text{ in.}$

The development length  $l_d$  for the positive-moment reinforcement (2 no. 8 bars) can be determined as follows:

Check if conditions for spacing and cover are met to select an equation. (ACI Code, Section 25.4.2.2)

$$d_b = 1 \text{ in.}$$

$$\text{clear cover} = 2 \text{ in.} > d_b$$

$$\text{clear spacing} = \frac{12 - 5}{1} - 1 = 6 \text{ in.} > 2d_b$$

$$\text{Condition met. Use } l_d = \frac{f_y \Psi_t \Psi_e}{20 \lambda \sqrt{f'_c}} (d_b)$$

Determine the multiplication factors. (ACI Code, Section 25.4.2.4)

$$\Psi_t = 1.3 \text{ (bottom bars)}$$

$$\Psi_e = 1.0 \text{ (no coating)}$$

$$\Psi_t \Psi_e < 1.7 \text{ OK}$$

$$\lambda = 1.0 \text{ (normal - weight concrete)}$$

$$\sqrt{f'_c} = \sqrt{4000} = 63.2 \text{ psi} < 100 \text{ psi ok}$$

Calculate  $l_d$  from: (ACI Code, Section 25.4.2.2)

$$l_d = \frac{f_y \Psi_t \Psi_e}{20 \lambda \sqrt{f'_c}} (d_b) = \frac{(60000)(1)(1)}{20(1)\sqrt{4000}} (1) = 47.43 \text{ in.} \geq 12 \text{ in.}$$



## c. Design the Column at C

1. Calculate effective length factors (assume column is fixed at both ends):

$$\Psi_A = \Psi_B = \frac{\frac{\sum E_c I_c}{L_c}}{\frac{\sum E_b I_b}{L_b}} = 0, \text{ since fixed at both ends}$$

2. Find
- $k$
- :

Using the Alignment Charts (Figure 12.3),  $k = 0.5$ 

3. Check Slenderness of Column West/East side (unbraced frame): (ACI Code, Section 6.2.5)

$$\frac{kL_u}{r} \leq 22$$

$$L_u = (16 \text{ ft}) - 6 \left( \frac{25}{12} \right) - 4 \text{ ft} = 9.92 \text{ ft}$$

$$r = 0.3h = 0.3 \left( \frac{12}{12} \right) = 0.3 \text{ ft}$$

$$\frac{kL_u}{r} = \frac{0.50(9.92)}{0.3} = 16.53$$

$$16.53 \leq 22$$

 $\therefore$  Slenderness effects permitted to be neglected  $\rightarrow$  short column.

4. Column design calculations—west/east side direction

$M_u$ (K.ft)	11.65
$P_u$ (K)	27.45
$h$ (in.)	12

$$A_g = (12 \text{ in.})(12 \text{ in.}) = 144 \text{ in.}^2$$

$$\gamma h = 12 - (2 \text{ in. cover}) - (2 \text{ in. cover}) = 8 \text{ in.}$$

$$\gamma = \frac{\gamma h}{h} = \frac{8}{12} = 0.67$$

$$\phi = 0.65 \text{ (ACI 21.2.1)}$$

$$M_n = \frac{(11.65 \text{ K} \cdot \text{ft})(12)}{0.65} = 215.08 \text{ K} \cdot \text{in.}$$

$$R_n = \frac{P_n e}{f'_c A_g h} \rightarrow P_n e = M_n$$

$$R_n = \frac{215.08}{4(144)(12)} = 0.03$$

$$P_n = \frac{P_u}{\phi} = \frac{27.45}{0.65} = 42.23 \text{ K}$$

$$K_n = \frac{P_n}{f'_c A_g} = \frac{42.23}{4(144)} = 0.07$$

From Figure 11.16 charts (c) and (d) in the textbook,  $\rho_g = 0.01$ 

$$A_s = \rho_g A_g = 0.01(144 \text{ in.}^2) = 1.44 \text{ in.}^2 \text{ use 4 no.6 bars; } d_b = 0.75 \text{ in.}$$

$$0.01A_g \leq A_s \leq 0.08A_g \text{ (ACI Code, Section 10.6.1.1)}$$

5. Column design calculations—north/south direction:

$M$ (K.ft)	2.98
$P_u$ (K)	27.45
$h$ (in.)	12

$$M_n = \frac{(2.98 \text{ K} \cdot \text{ft}) \left(12 \frac{\text{in}}{\text{ft}}\right)}{0.65} = 55.01 \text{ K} \cdot \text{in.}$$

$$R_n = \frac{55.01}{4(144)(12)} = 0.007$$

$$K_n = \frac{P_n}{f'_c A_g} = \frac{42.23}{4(144)} = 0.07$$

From Figure 11.16 charts (c) and (d),  $\rho_g = 0.01$

$$A_s = \rho_g A_g = 0.01(144 \text{ in.}^2) = 1.44 \text{ in.}^2 \rightarrow 4 \# 6 \text{ bars; } d_b = 0.75 \text{ in.}$$

$$0.01A_g \leq A_s \leq 0.08A_g$$

6. Design for ties: (ACI Code, Section 25.7.2)

No. 3 ties for longitudinal reinforcement bars size no. 10 or smaller  $\rightarrow d_{\text{tie}} = 0.375 \text{ in.}$

Vertical spacing of ties shall be the smallest of:

$$16d_{\text{bar}} = 16(0.75 \text{ in.}) = 12 \text{ in. (governs)}$$

$$48d_{\text{tie}} = 48(0.375 \text{ in.}) = 18 \text{ in.}$$

Least dimension of compression member = 12 in.

7. Check for splice length in compression:

$$l_{\text{sc}} = 0.0005f_y d_b = 0.0005(60000)(0.75) = 22.5 \text{ in.} \geq 12 \text{ in. (ACI 25.5.5.1)}$$

8. Check for splice length in tension (ACI Code, Section 25.4.2.4)

Since  $\frac{A_s \text{ provided}}{A_s \text{ required}} < 2$ , use Class B splice:  $1.3l_d$  (ACI Code, Section 25.5.2.1)

$$1.3l_d = 1.3 \left( \frac{f_y \psi_t \psi_e}{20\lambda \sqrt{f'_c}} \right) d_b = (1.3) \frac{60000(1)(1)}{(20)(1)(\sqrt{4000})} (0.75) = 46.25 \text{ in.} \geq 12 \text{ in.}$$

9. Details of column cross section is shown in Figure 23.15

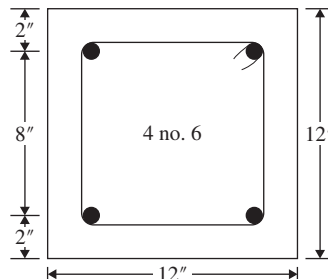


Figure 23.15 Cross section details of column C.

**d. Design the Footing at C**

1. Calculate the effective soil pressure.

Assume a total depth of footing 1.5 ft

The weight of the footing is  $1.5 \times 150 = 225$  psf

(Assume concrete unit weight = 150 pcf)

The weight of soil above the footing is  $(4 - 1.5) \times 130 = 325$  psf

(Assume soil unit weight = 130 pcf)

Effective soil pressure =  $4 - 225/1000 - 325/1000 = 3.45$  ksf

2. Calculate the area of the footing:

Actual loads =  $DL + LL = 30 + 8 = 38$  KArea of footing =  $\frac{38}{3.45} = 11.01$  ft<sup>2</sup>

Side of footing = 3.32 ft, use 4 ft

3. Calculate net upward pressure equals (factored load)/(area of footing):

$$P_u = 1.2DL + 1.6LL$$

$$P_u = 1.2(30) + 1.6(8) = 48.80 \text{ K}$$

$$\text{Net upward pressure, } q_u = \frac{P_u}{A} = \frac{48.80}{(4 \times 4)} = 3.05 \text{ ksf}$$

4. Check depth due to two-way shear. Assume bar no. 8 bars both ways. Calculate
- $d$
- to the centroid of the top steel layer:

$$d = 18 - 3(\text{cover}) - 1.5(\text{bar diameters}) = 13.5 \text{ in.}$$

$$b_0 = 4(c + d) = 4(12 + 13.5) = 102 \text{ in.}$$

$$c + d = 12 + 13.5 = 25.5 \text{ in.} = 2.125 \text{ ft}$$

$$V_{u2} = P_u - q_u(c + d)^2 = 48.80 - 3.05(2.125)^2 = 35.03 \text{ K}$$

$$\text{Required } d_1 = \frac{V_{u2}}{4\phi\lambda\sqrt{f'_c}b_0} = \frac{35.03(1000)}{4(0.75)(1)\sqrt{4000}(102)} = 1.81 \text{ in.}$$

$$\beta = \frac{L}{W} = \frac{4}{4} = 1 \text{ (Eq. 13.9)}$$

since  $\beta \leq 2$ 

$$\text{Required } d_2 = \frac{35.03(1000)}{0.75\left(\frac{20 \times 13.5}{102} + 2\right)(\sqrt{4000})(102)} = 1.56 \text{ in. (not critical)}$$

 $(\alpha_s = 20$  for corner columns.) Thus, the assumed depth is adequate.

5. Check depth due to one-way shear. The critical section is at distance
- $d$
- from the face of the column:

$$\text{Distance to critical section} = \left(\frac{L}{2} - \frac{c}{2} - d\right) = \left(\frac{4}{2} - \frac{1}{2} - \frac{13.5}{12}\right) = 0.375 \text{ ft}$$

$$V_{u1} = q_u b \left(\frac{L}{2} - \frac{c}{2} - d\right) = 3.05 \times 4 \times 0.375 = 4.58 \text{ K}$$

The depth required for one-way shear is

$$d = \frac{V_{u1}}{2\phi\lambda\sqrt{f'_c}b} = \frac{4.58(1000)}{2(0.75)(1)\sqrt{4000}(4 \times 12)} = 1.00 \text{ in.} < 13.5$$

6. Calculate the bending moment and steel reinforcement. The critical section is at the face of the column.

The distance from the edge of footing is  $\left(\frac{L}{2} - \frac{c}{2}\right) = \frac{4}{2} - \frac{1}{2} = 1.5$  ft

$$M_u = 0.5q_u \left(\frac{L}{2} - \frac{c}{2}\right)^2 (b) = 0.5(3.05)(1.5)^2(4) = 13.73 \text{ K} \cdot \text{ft}$$

$$R_u = \frac{M_u}{bd^2} = \frac{13.73 (12000)}{(4 \times 12) (13.5)^2} = 18.83 \text{ psi}$$

$$\rho = \frac{0.85 f'_c}{f_y} \left[ 1 - \sqrt{1 - \frac{2R_u}{\phi 0.85 f'_c}} \right]$$

$$\rho = \frac{0.85 \times 4000}{60000} \left[ 1 - \sqrt{1 - \frac{2 \times 18.83}{0.9 \times 0.85 \times 4000}} \right] = 0.0003$$

$$A_s = \rho bd = (0.0003)(4.00)(13.5) = 0.23 \text{ in.}^2$$

$$\text{Minimum } A_s \text{ (shrinkage steel)} = (0.0018)(4.00)(13.5) = 1.17 \text{ in.}^2$$

$$\text{Minimum } A_s \text{ (flexure)} = (0.0033)(4.00)(13.5) = 2.14 \text{ in.}^2$$

Therefore,  $S = 2.14 \text{ in.}^2$ . Use 11 no. 4 bars ( $S_s = 2.16 \text{ in.}^2$ )

Determine bar spacing  $s = \frac{(4 \times 12) - 6}{10} = 4.2 \text{ in.}$

Use no. 11 @ 4 in. c/c both directions

7. Check bearing stress:

- (a) Bearing strength,  $N_1$ , at the base of the column is:

$$A_1 = c_1 * c_2 = 12 \times 12 = 144 \text{ in.}^2$$

$$N_1 = \phi(0.85f'_c)A_1 = (0.65)(0.85 \times 4)(144) = 318.24 \text{ K}$$

- (b) Bearing strength,  $N_2$ , of footing is:

$$N_2 = N_1 \sqrt{\frac{A_2}{A_1}} \leq 2N_1$$

$$A_2 = 4 \times 4 \times 144 = 2304 \text{ in.}^2$$

$$A_1 = 12 * 12 = 144 \text{ in.}^2$$

$$N_2 = N_1 \sqrt{\frac{2304}{144}} = 4N_1$$

$$\text{therefore, } N_2 = 2N_1 = 636.48 \text{ K}$$

$P_u < N_2$  therefore bearing is adequate

The minimum area of dowels required is  $0.005A_1 = 0.005(12 \times 12) = 0.72 \text{ in.}^2$ . The minimum number of bars is four, so use four no. 4 bars placed at the four corners of the column.

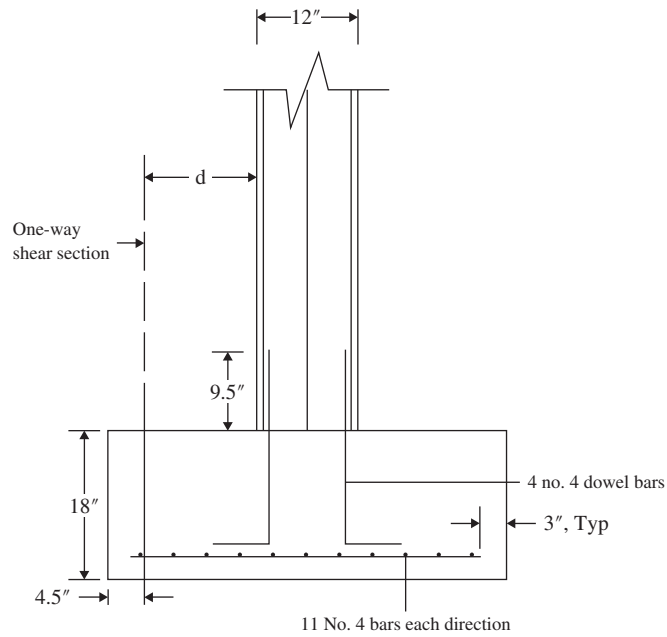
- (c) Development length of dowels in compression:

$$l_{dc} = \left(\frac{0.02f_y}{\lambda \sqrt{f'_c}}\right) d_b = \left(\frac{(0.02)(60000)}{(1)\sqrt{4000}}\right) 0.50 = 9.49 \text{ in.} = 9.5 \text{ in. (controls)}$$

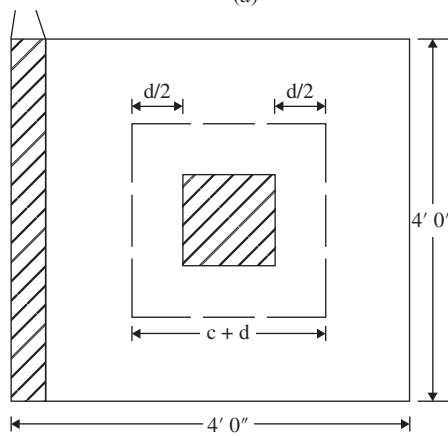
Therefore, use four no. 4 dowels extending 9.5 in. into column and footing. Note that  $l_{dc}$  is less than  $d$  of 13.5 in., which is adequate.

8. The development length of main bars in the footing for no. 4 bars is  $l_d = 19d_b = 9.5$  in. (refer to Chapter 7), provided  $l_d = \frac{L}{2} - \frac{c}{2} - 3$  in. = 15 in.

Details of the footing are shown in Figure 23.16.



(a)



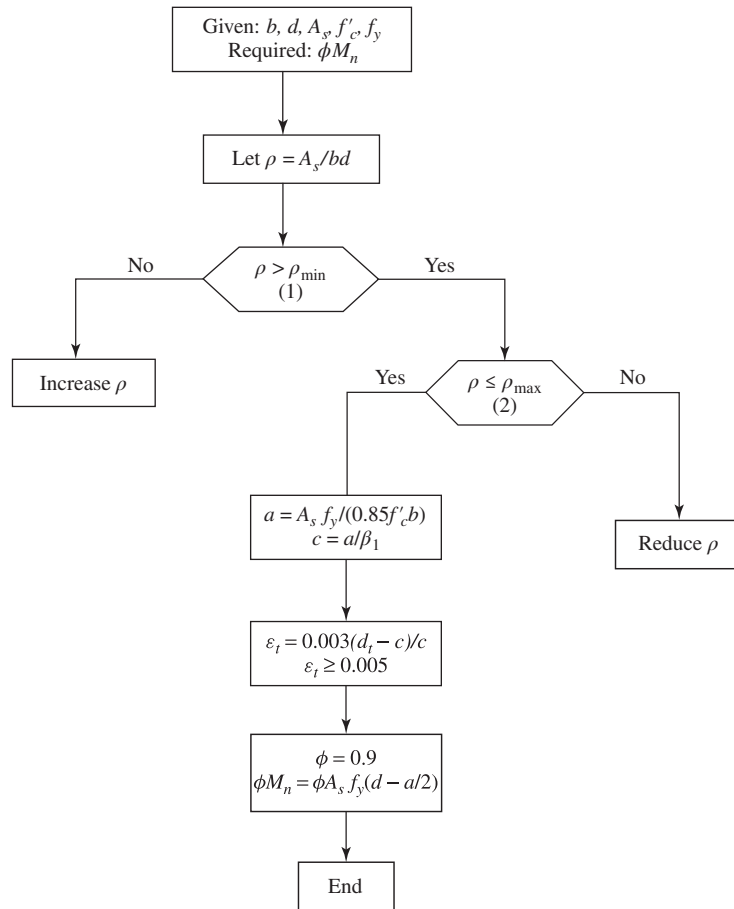
(b)

**Figure 23.16** Footing details

# DESIGN AND ANALYSIS FLOWCHARTS

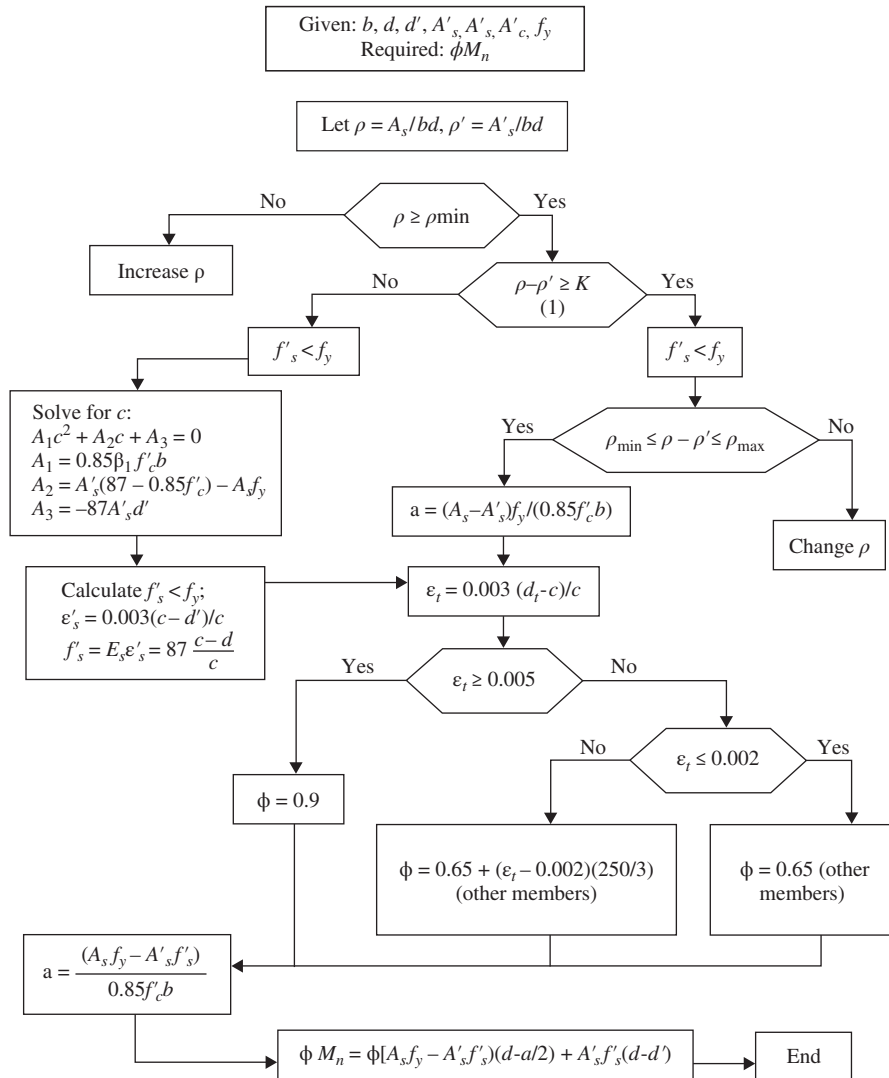
To help the student and design engineer to prepare their own programs, flowcharts are given for most chapters.

1. Flowcharts 24.1, 24.2, and 24.3 explain the analysis of single, double, and T-sections (Chapter 3).
2. Flowcharts 24.4, 24.5, and 24.6 explain the design of single, double, and T-sections (Chapter 4).
3. Flowchart 24.7 explains shear design (Chapter 5).
4. Flowchart 24.8 explains the calculation of development length (Chapter 7).
5. Flowchart 24.9 explains the analysis of rectangular columns at balanced condition (Chapter 11).
6. Flowchart 24.10 explains the analysis of rectangular columns (Chapter 11).
7. Flowchart 24.11 explains the design of rectangular or square footings (Chapter 13).
8. Flowchart 24.12 explains the design for combined shear and torsion (Chapter 15).
9. Flowchart 24.13 explains Two-way slabs by the direct design method (Chapter 17).
10. Flowchart 24.14 explains general bridge superstructure design (Chapter 22).
11. Flowchart 24.15 explains bridge prestressing losses calculation (Chapter 22).
12. Flowchart 24.16 explains bridge live-load distribution factor calculation (Chapter 22).
13. Flowchart 24.17 explains bridge deck slab design (Chapter 22).
14. Flowchart 24.18 explains bridge flexure design (Chapter 22).
15. Flowchart 24.19 explains bridge shear design (Chapter 22).



**Flowchart 24.1** Analysis of single reinforced rectangular section.

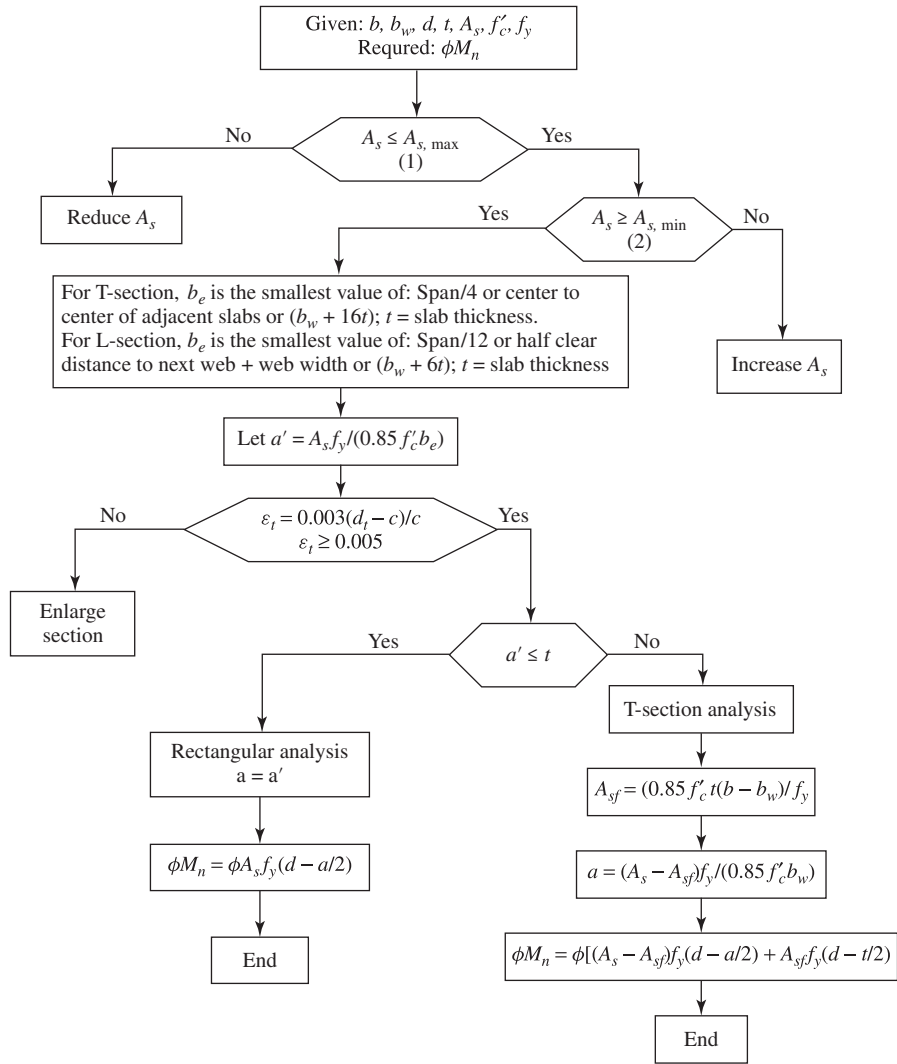
1.  $\rho_{min} = 3 \sqrt{\frac{f'_c}{f_y}} \geq \frac{200}{f_y}$
2.  $\rho_b = (0.85\beta_1) \left( \frac{f'_c}{f_y} \right) \left( \frac{87}{87 + f_y} \right)$   
 $\rho_{max} = \left( \frac{0.003 + f_y/E_s}{0.008} \right) \rho_b$



**Flowchart 24.2** Analysis of double reinforced rectangular section.

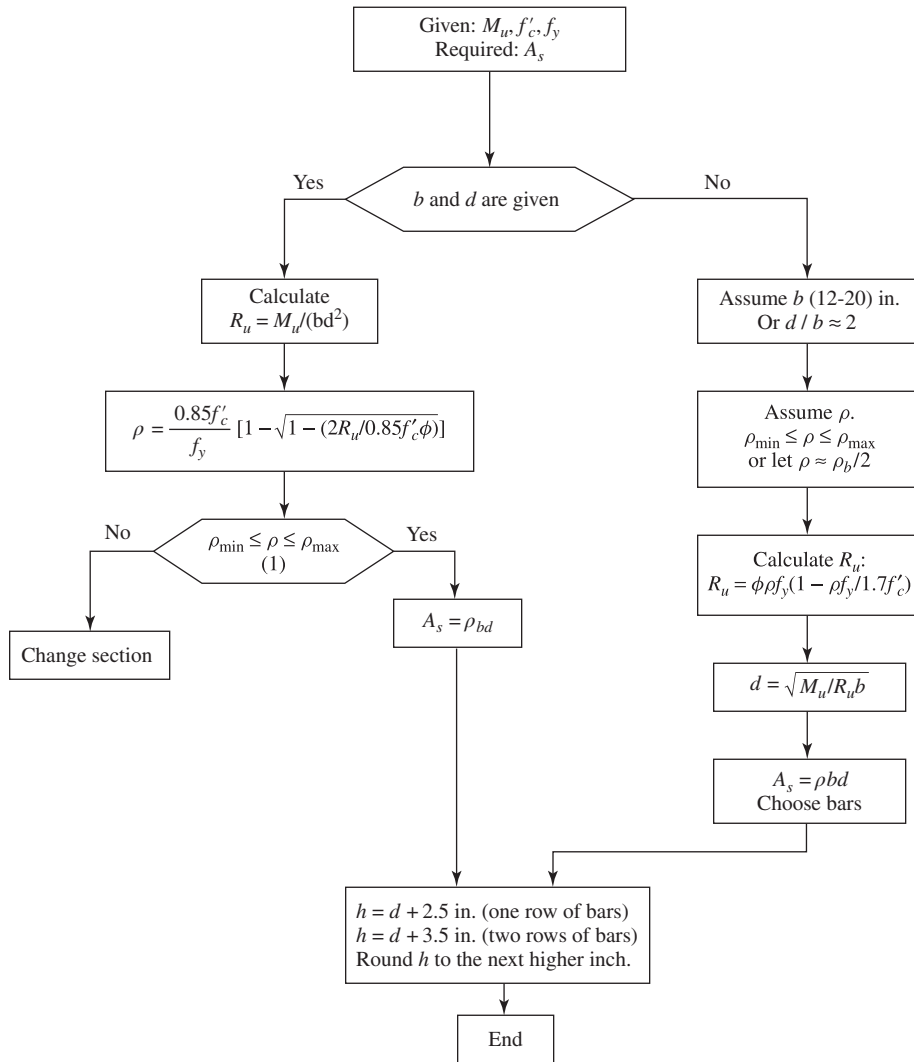
1.  $K = (0.85\beta_1) \left(\frac{f'_c}{f_y}\right) \left(\frac{d'}{d}\right) \left(\frac{87}{87-f_y}\right)$
2. Refer to Flowchart 24.1 to calculate  $\rho_{\min}$  and  $\rho_{\max}$ .





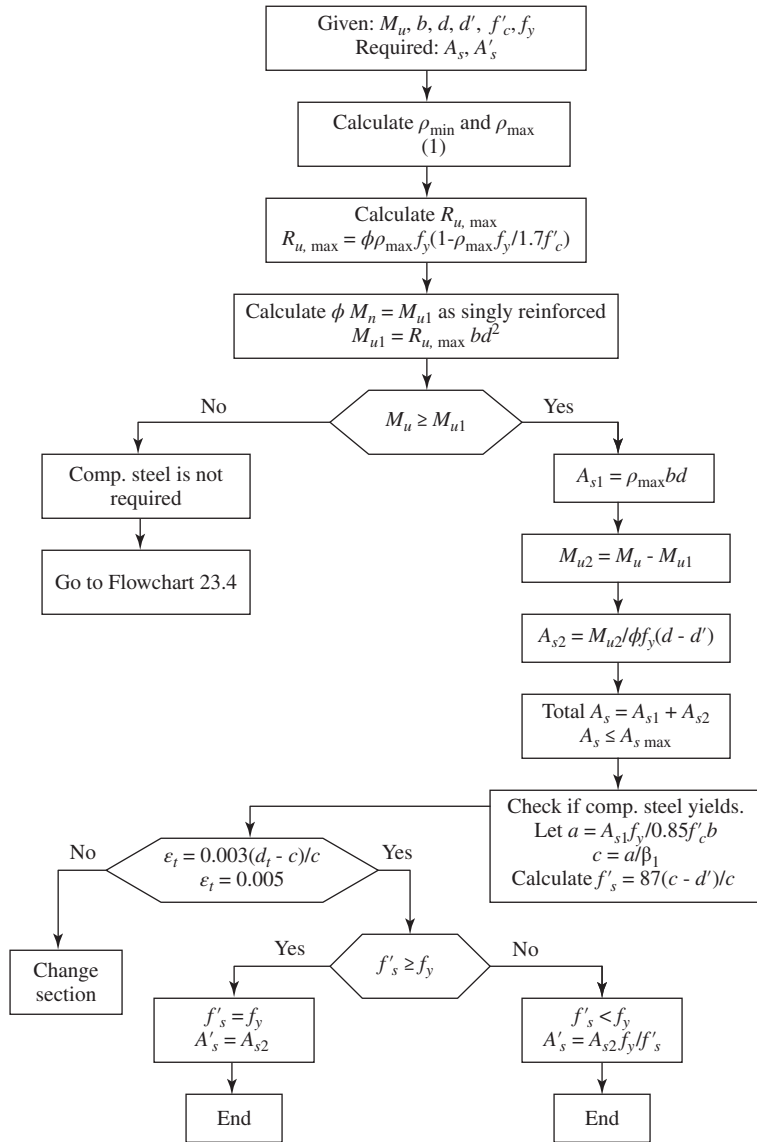
**Flowchart 24.3** Analysis of T- and L-sections.

1.  $A_{s, \max} = 0.6375 \left( \frac{f'_c}{f_y} \right) [t(b - b_w) + 0.375b_w \beta_1 d]$
2.  $A_{s, \min} = \left[ \frac{3\sqrt{f'_c}}{f_y} \right] b_w d \geq \left[ \frac{200}{f_y} \right] b_w d$



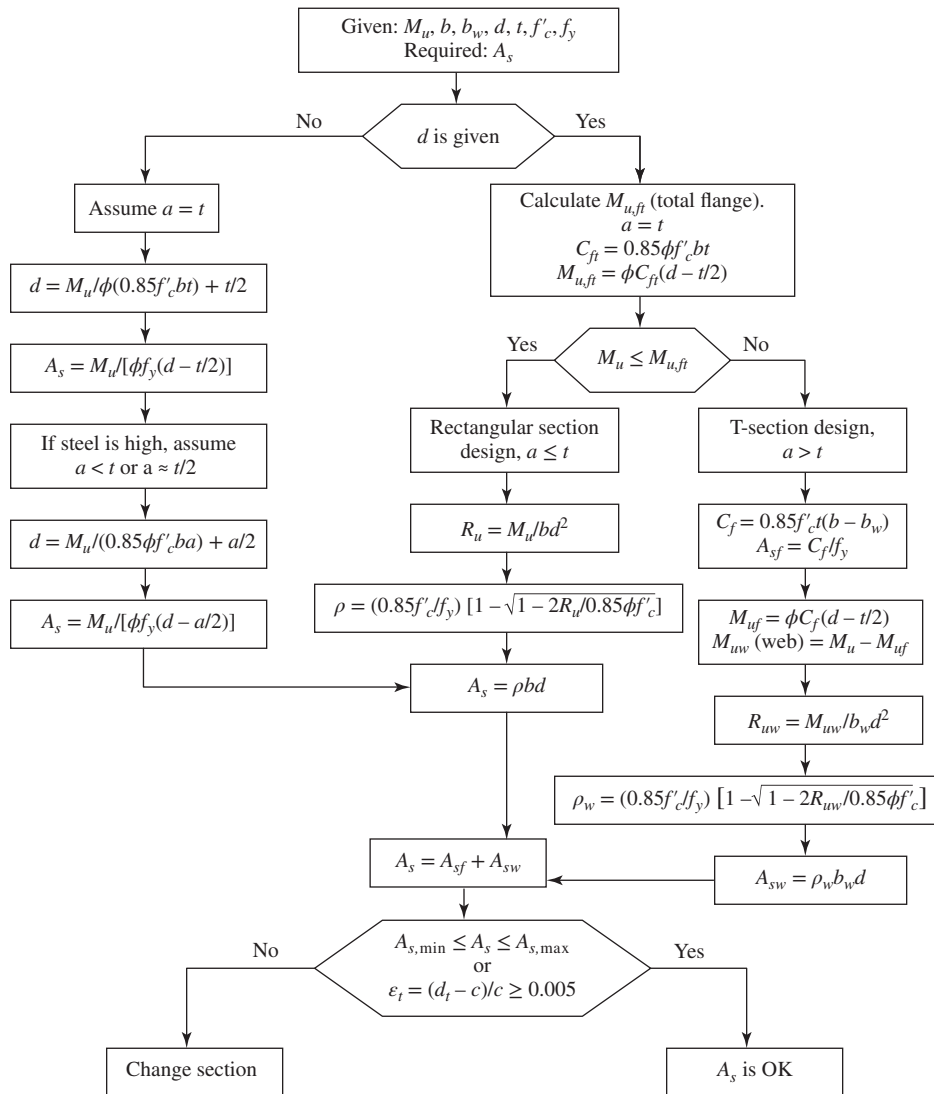
**Flowchart 24.4** Design of single reinforced rectangular section.

1. Refer to Flowchart 24.1 to calculate  $\rho_{min}$  and  $\rho_{max}$ .

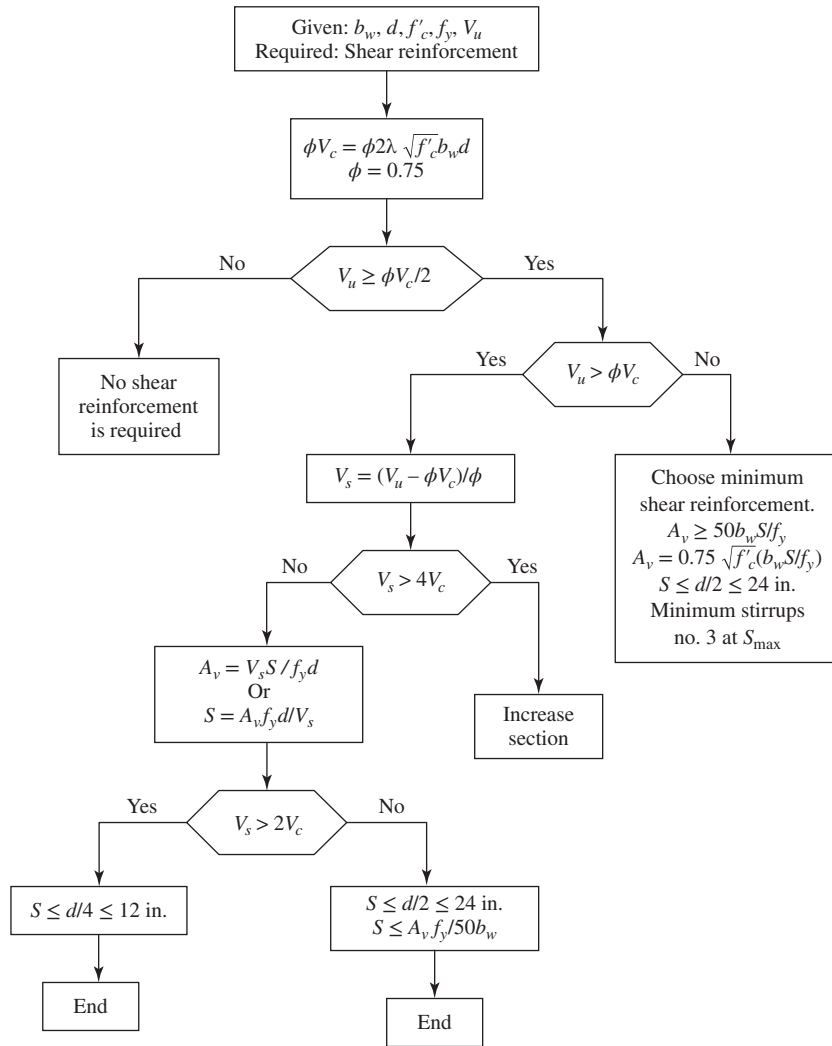


**Flowchart 24.5** Design of rectangular sections with compression steel.

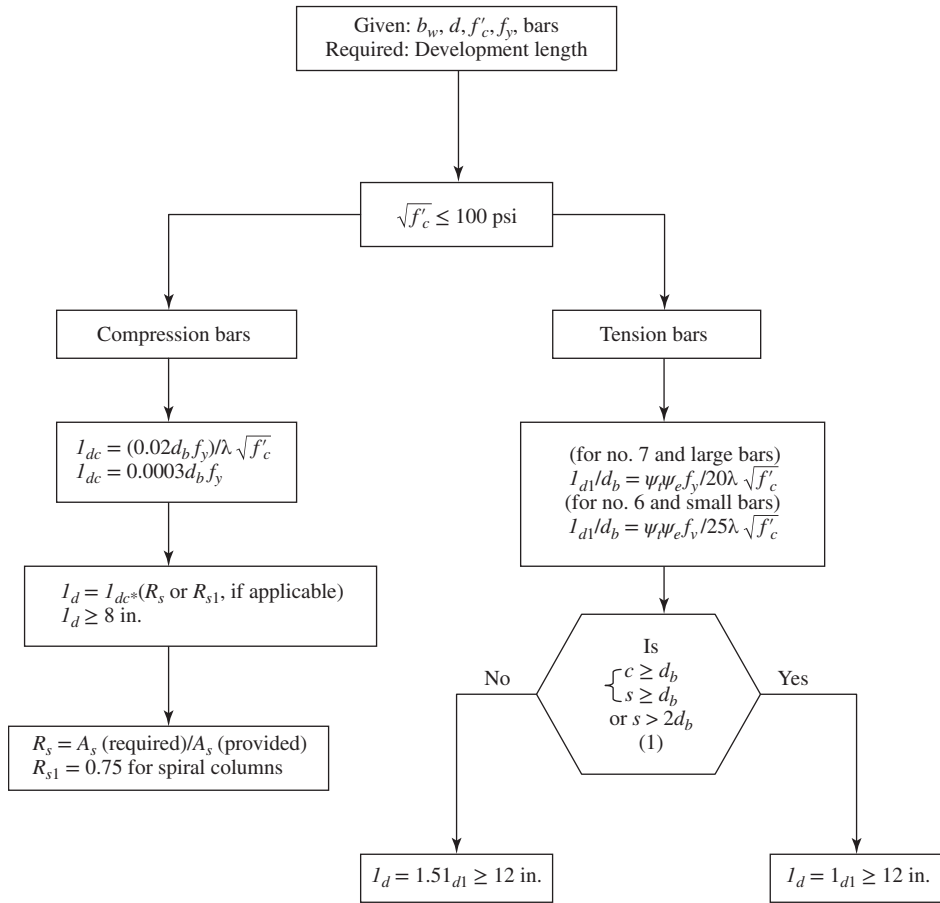
Refer to Flowchart 24.1 to calculate  $\rho_{\min}$  and  $\rho_{\max}$ .



Flowchart 24.6 Design of T- or L-sections.

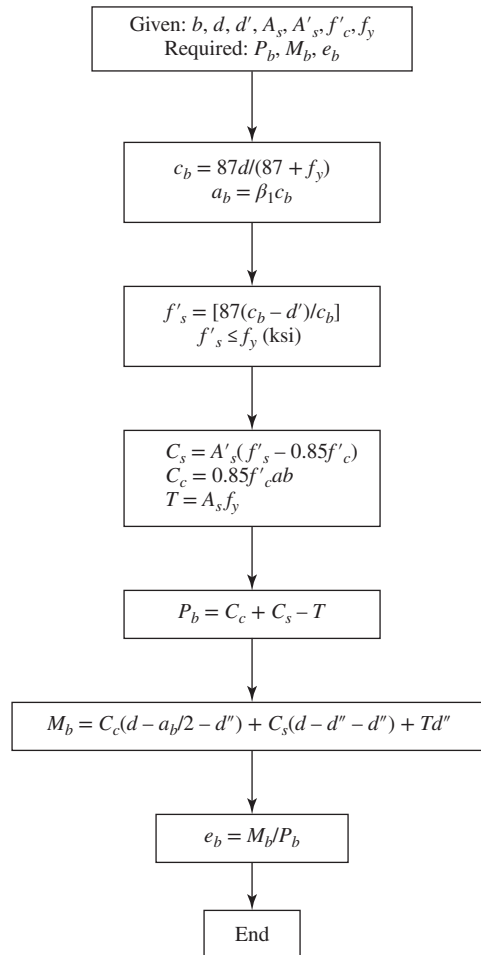


Flowchart 24.7 Shear design.

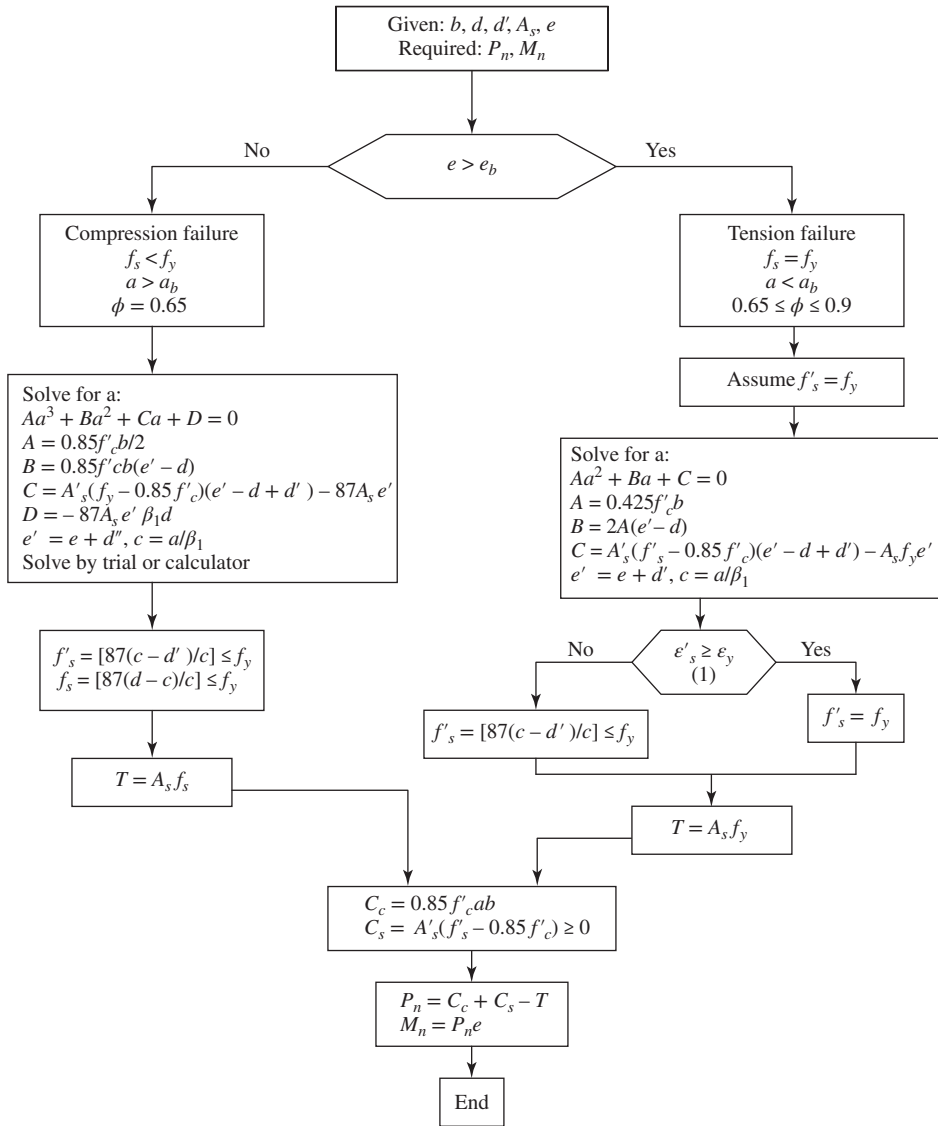


**Flowchart 24.8** Calculation of development length.

1.  $c$  = clear cover  
 $s$  = clear spacing



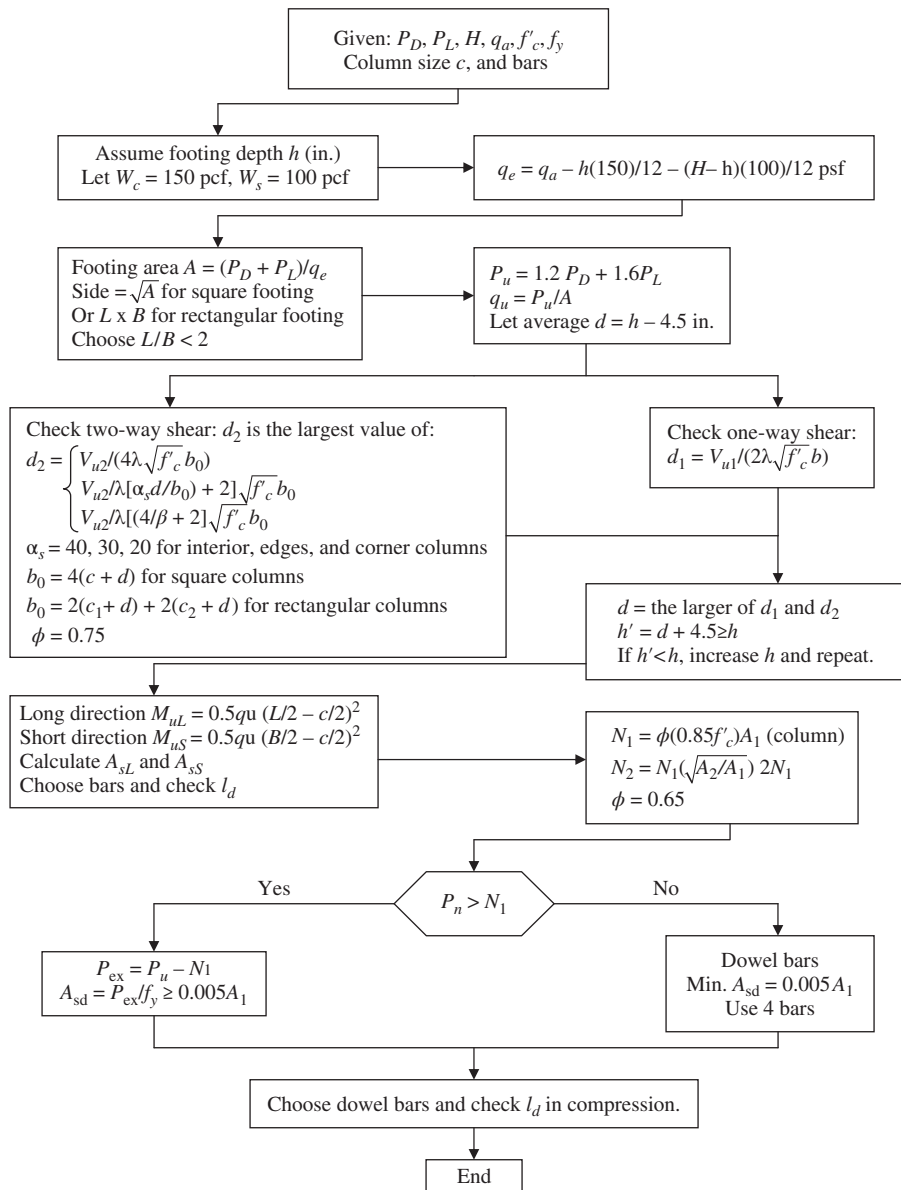
**Flowchart 24.9** Balanced load, moment, and eccentricity for rectangular column sections. (Use ksi for  $f'_c$  and  $f_y$ ;  $d''$  = distance from the plastic centroid to  $A_{s'}$ .)



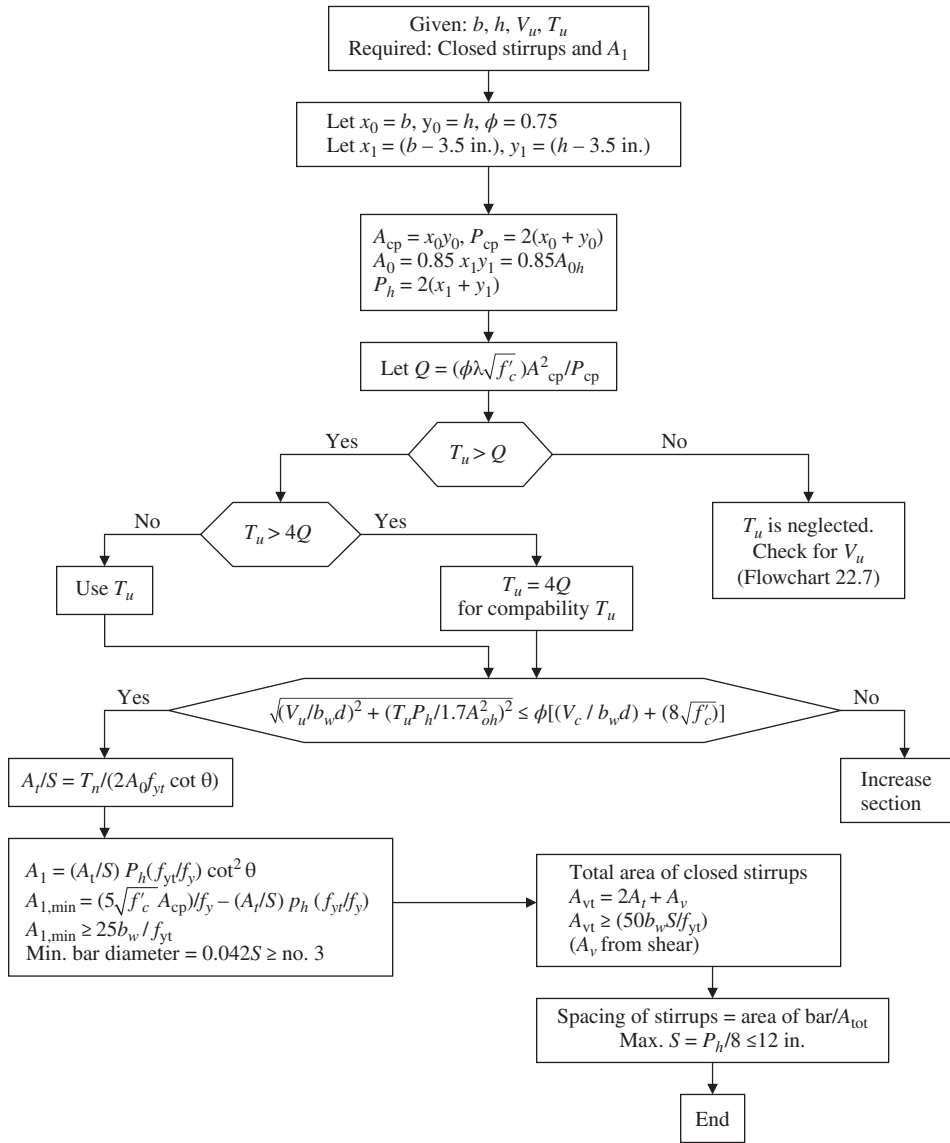
**Flowchart 24.10** Analysis of rectangular columns. (Use ksi for  $f'_c$  and  $f_y$ .)

1.  $\epsilon'_s = 0.003 \left( \frac{c-d'}{c} \right)$ ;  $\epsilon_y = \frac{f_y}{E_s}$

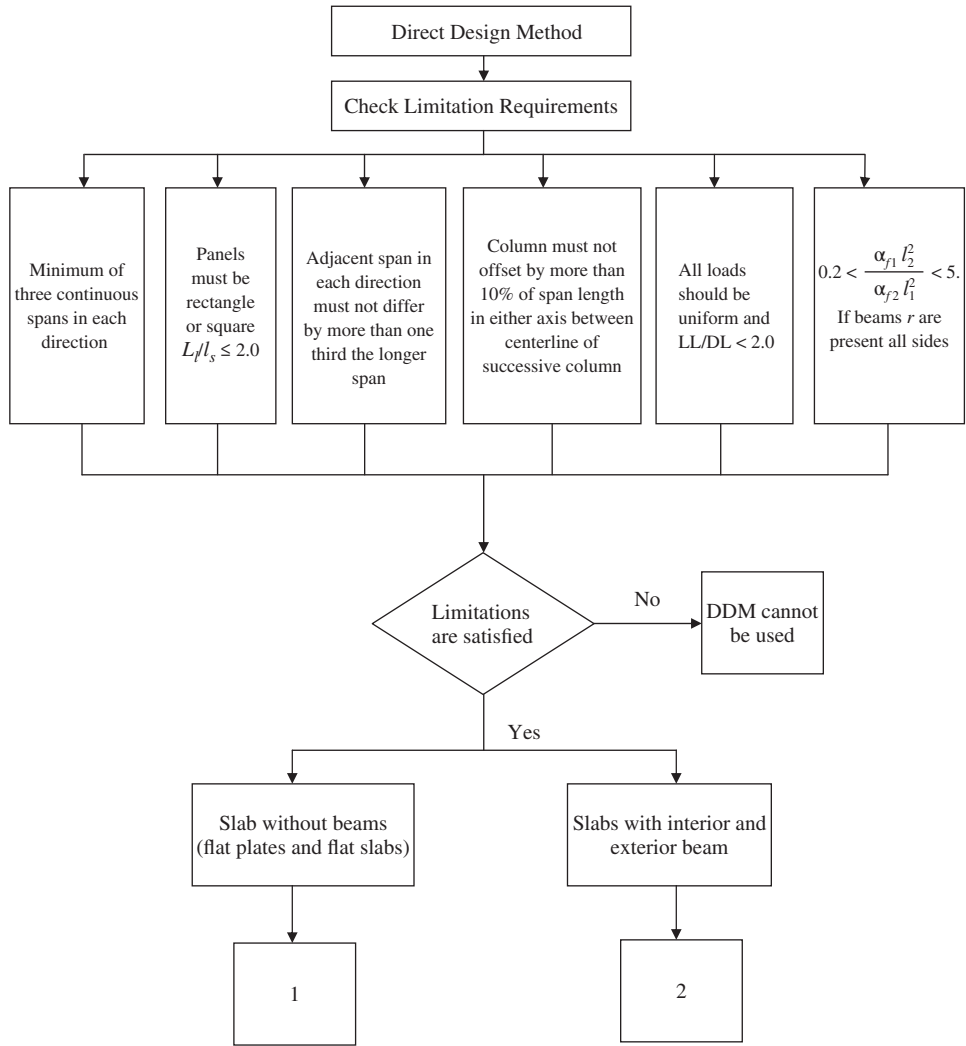




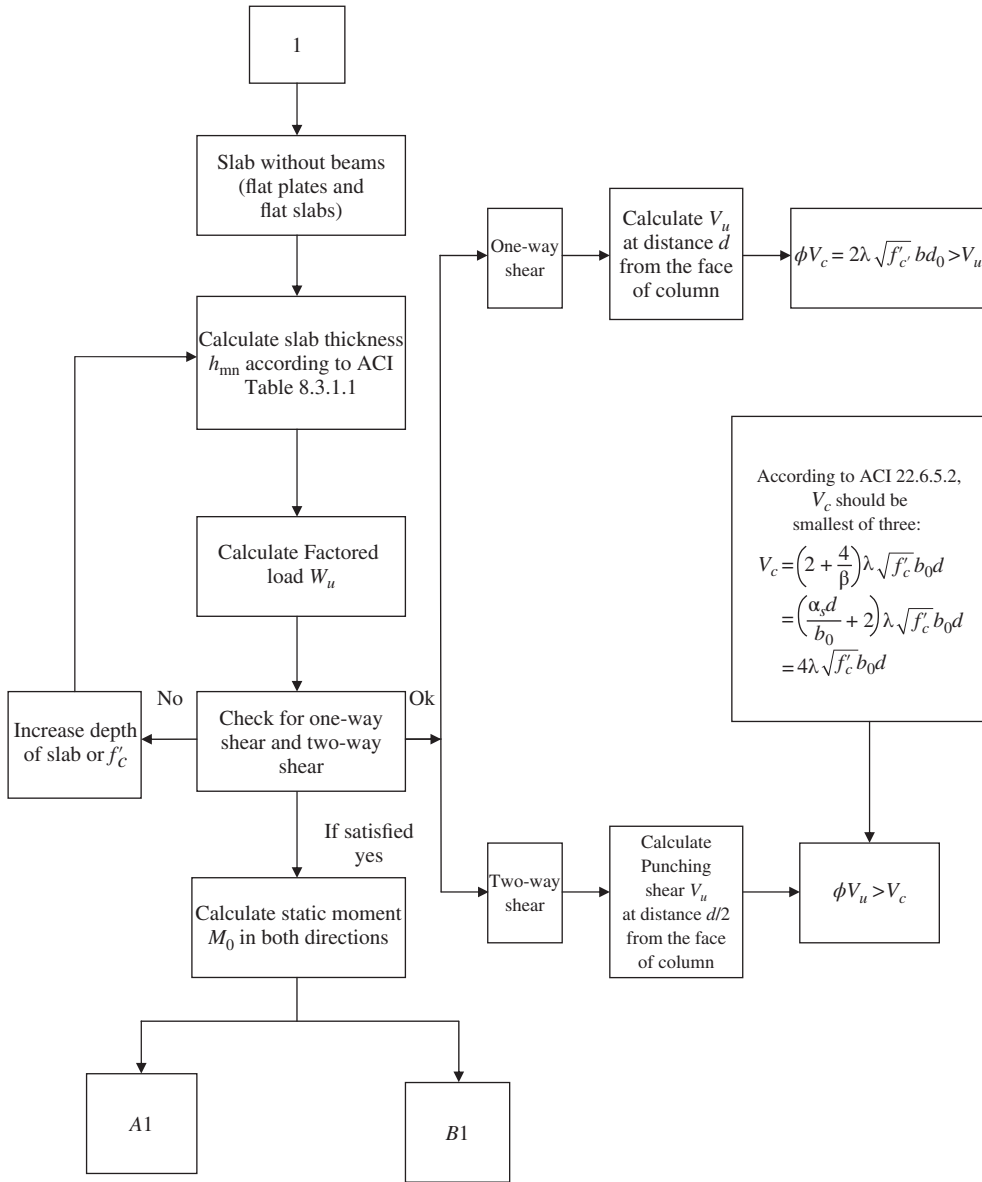
**Flowchart 24.11** Design of rectangular or square footings.



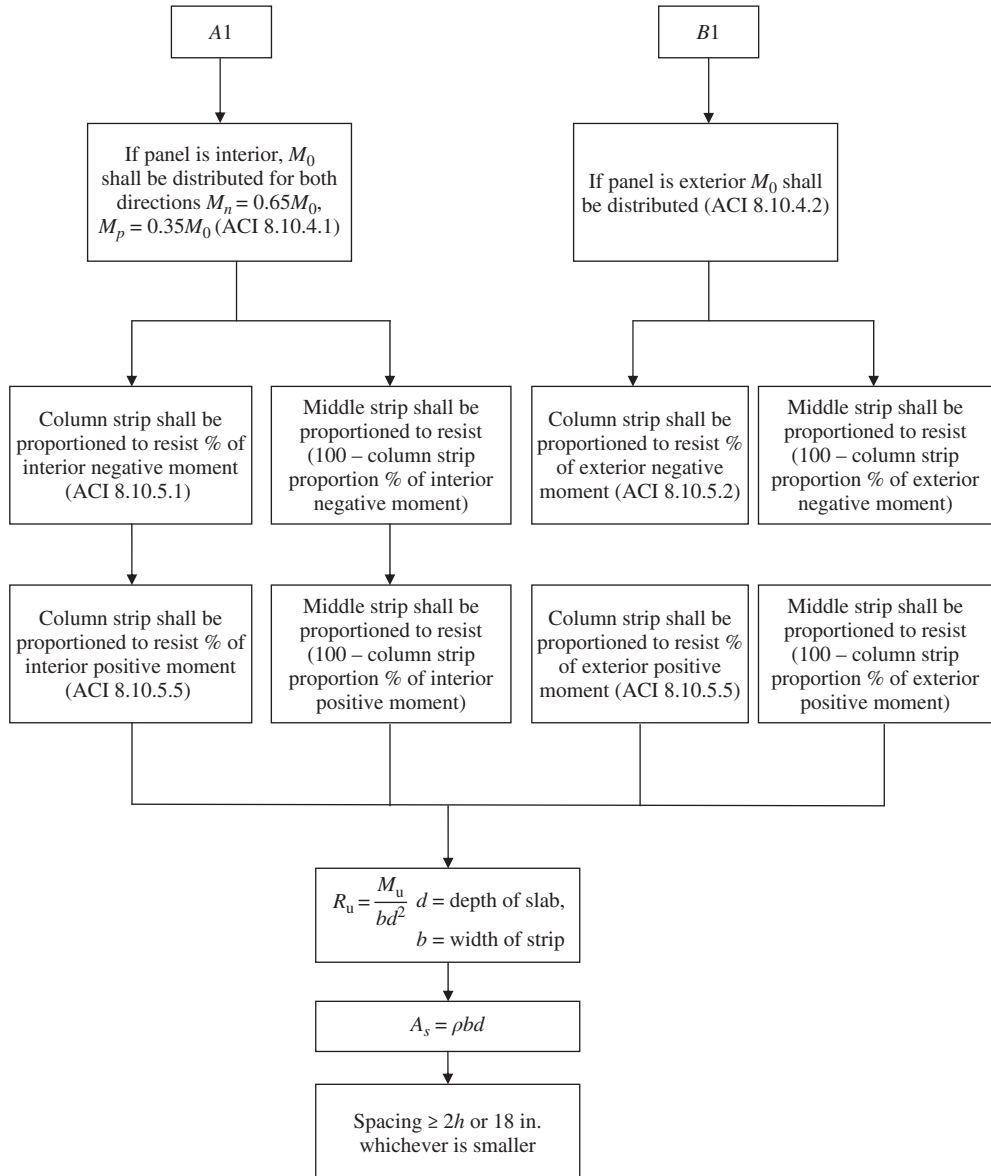
**Flowchart 24.12** Design for combined shear and torsion.



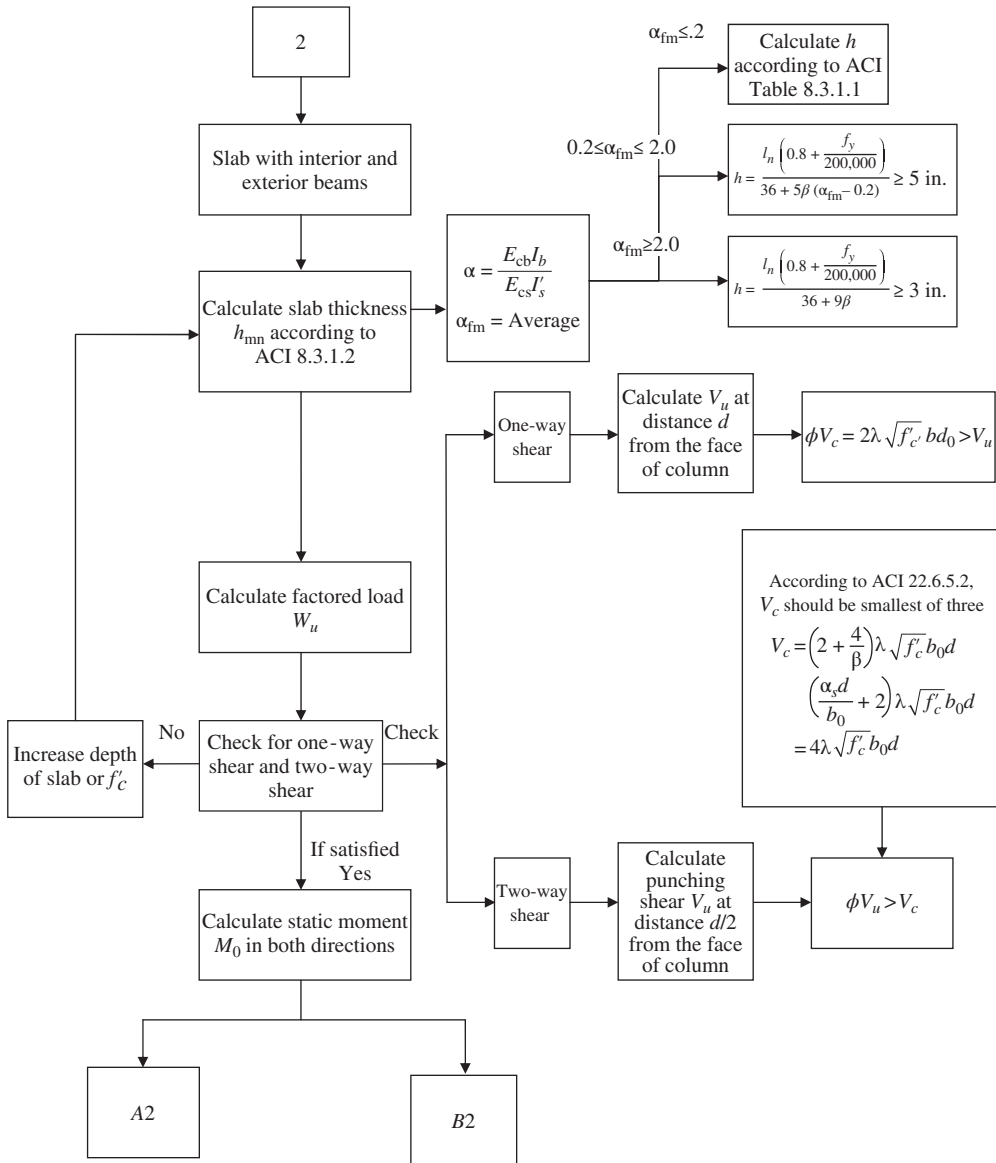
**Flowchart 24.13a** Two-way slab—DDM.



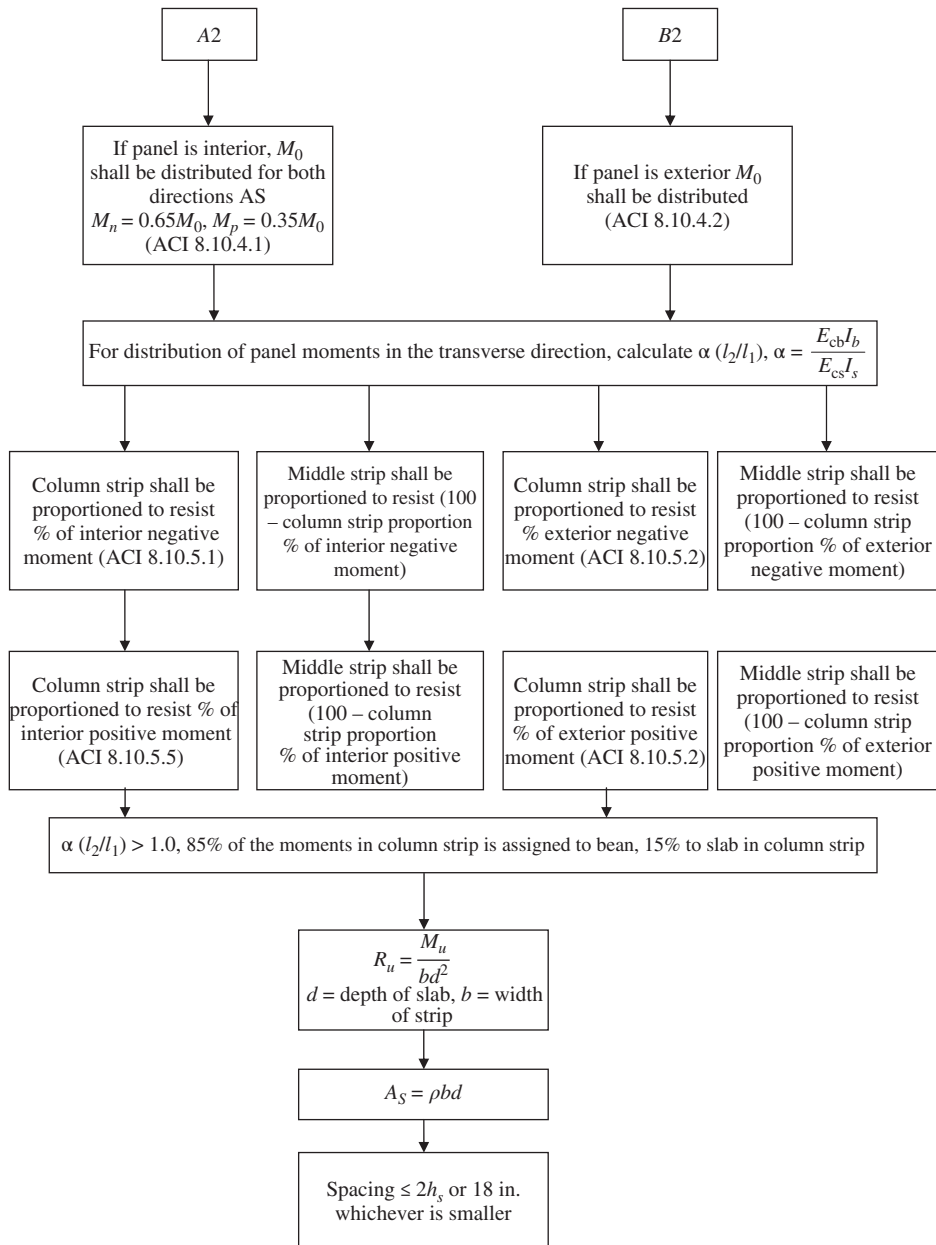
**Flowchart 24.13b** Two-way slab—DDM.



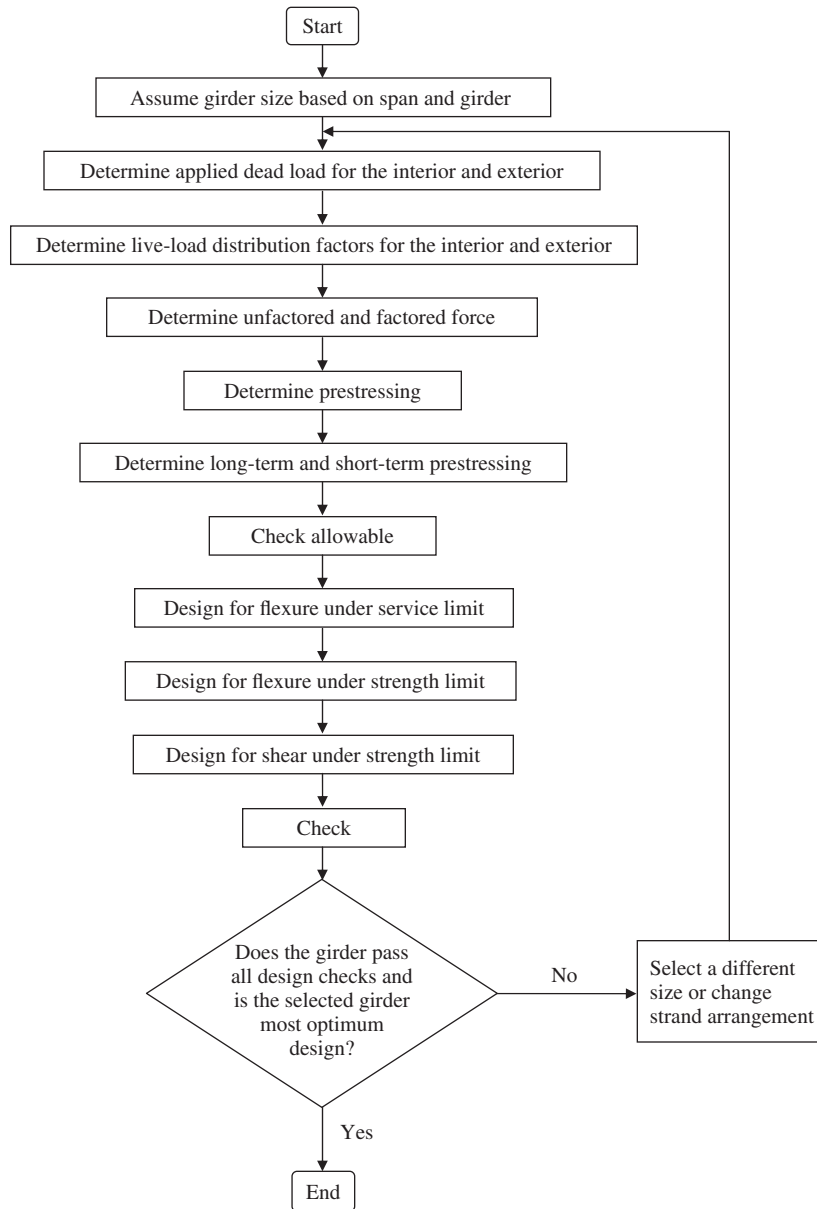
**Flowchart 24.13c** Two-way slab—DDM.



**Flowchart 24.13d** Two-way slab – DDM.

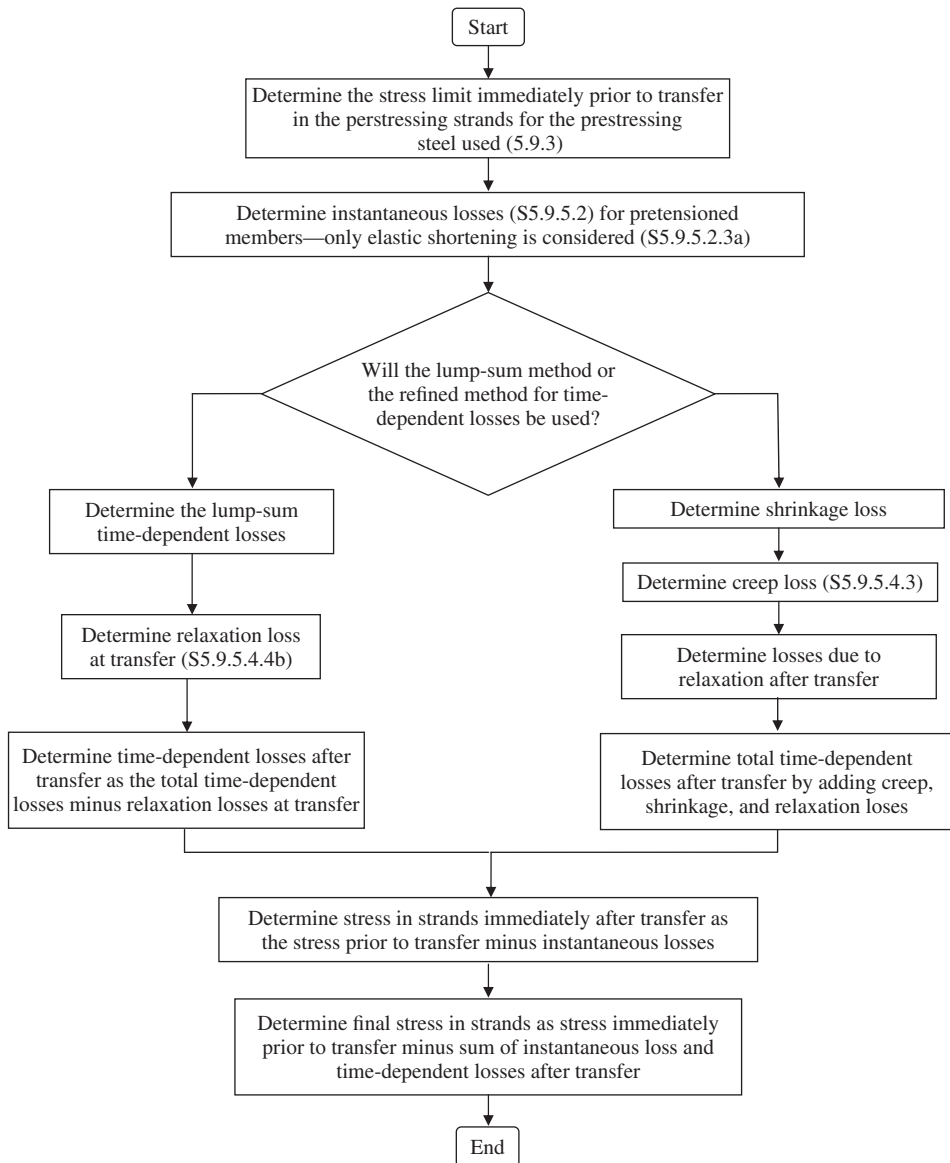


**Flowchart 24.13e** Two-way slab—DDM.

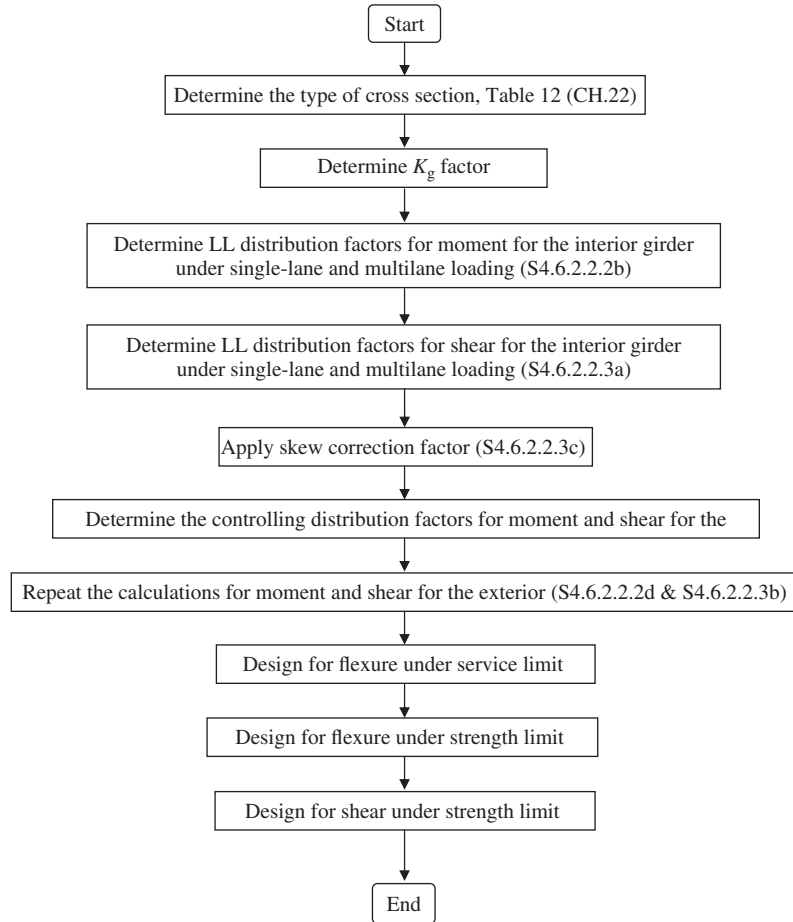


**Flowchart 24.14** Bridge superstructure design.

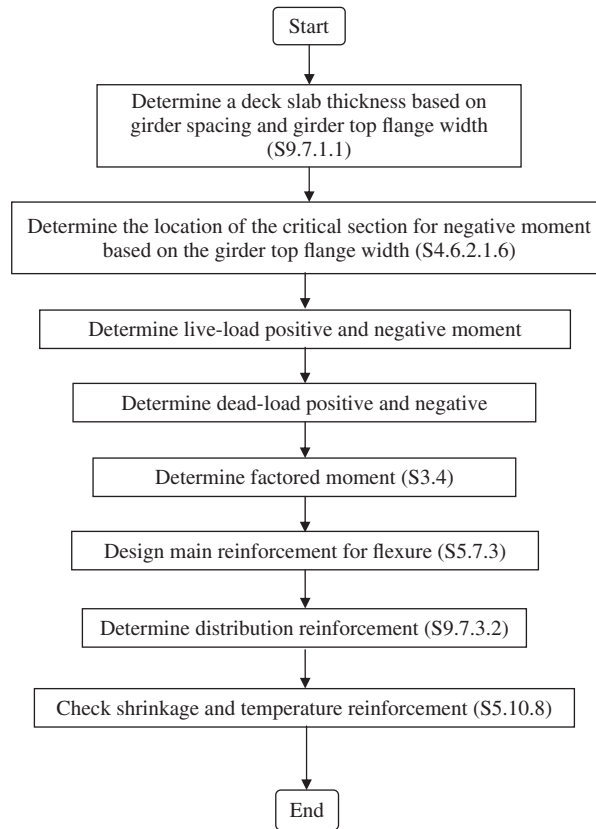




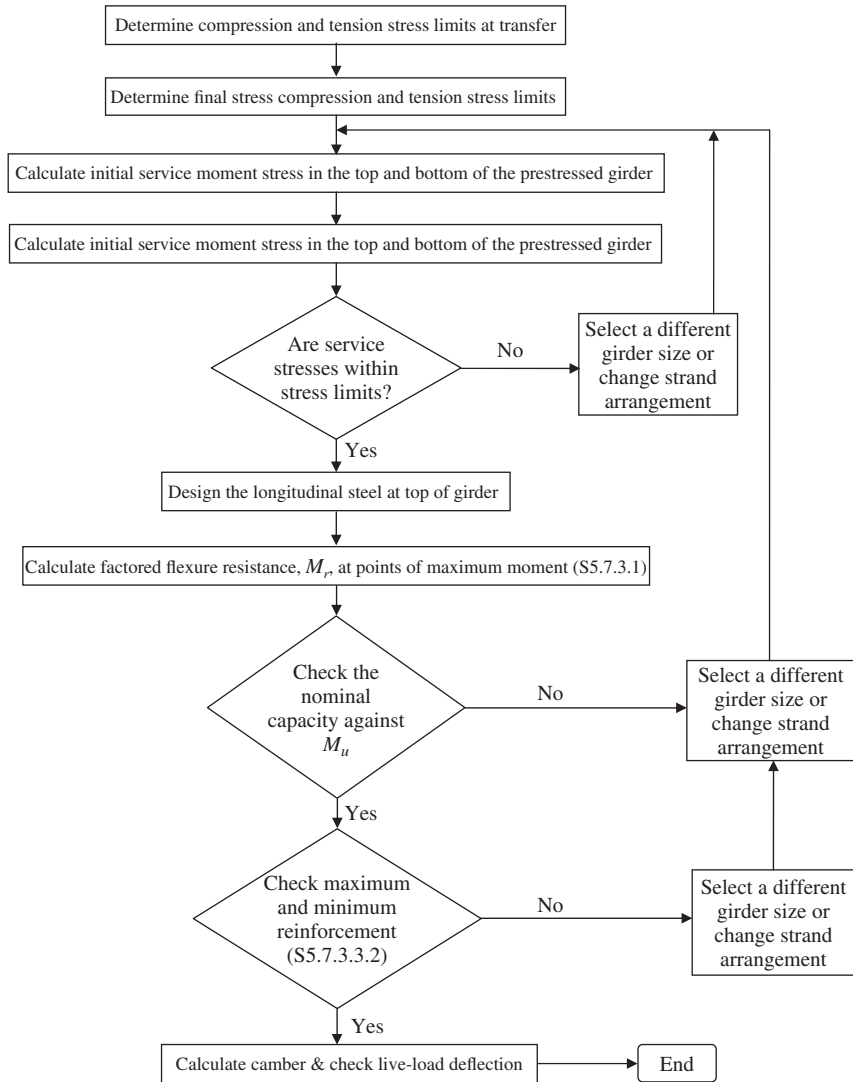
**Flowchart 24.15** Bridge prestressing losses calculation.



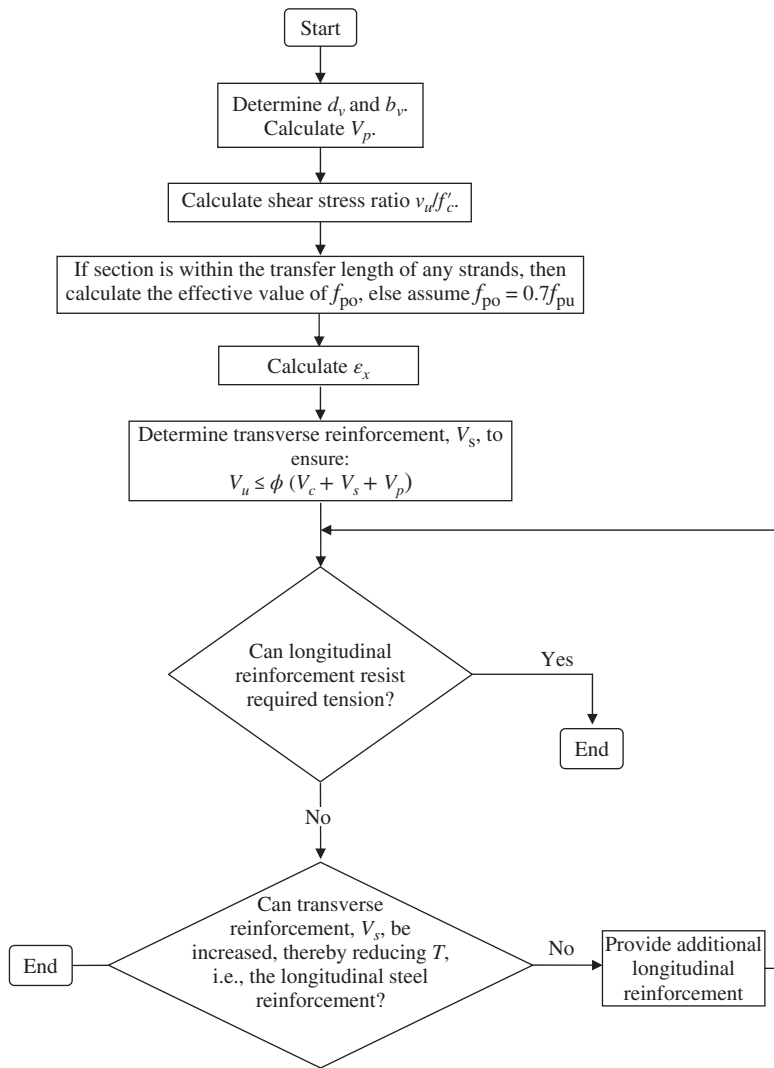
**Flowchart 24.16** Bridge live-load distribution factor calculation.



**Flowchart 24.17** Bridge deck slab design.



**Flowchart 24.18** Flexure design.



**Flowchart 24.19** Shear design.

**DESIGN TABLES  
(U.S. CUSTOMARY UNITS)**

**Table A.1** Values of  $R_u$  and  $\frac{a}{d}$  for  $f'_c = 3000$  psi

**Table A.2** Values of  $R_u$  and  $\frac{a}{d}$  for  $f'_c = 4000$  psi

**Table A.3** Values of  $R_u$  and  $\frac{a}{d}$  for  $f'_c = 5000$  psi

**Table A.4** Values of  $\rho_{\max}$ ,  $R_{u, \max}$ ,  $\rho_b$ , and  $\rho_{\min}$

**Table A.5** Suggested Design Steel Ratios,  $\rho_s$ , and Comparison with Other Values

**Table A.6** Minimum Thickness of Beams and One-Way Slabs

**Table A.7** Minimum Beam Width (in.) (Using Stirrups)

**Table A.8** Values of  $bd^2$  (in.<sup>3</sup>)

**Table A.9** Rectangular Sections with Compression Steel

**Table A.10** Values of Modulus of Elasticity,  $E_c$  (ksi)

**Table A.11** Development Length

**Table A.12** Designation, Areas, Perimeter, and Weights of Standard U.S. Bars

**Table A.13** Areas of Groups of Standard U.S. Bars in Square Inches

**Table A.14** Areas of Bars in Slabs (Square Inches per Foot)

**Table A.15** Common Styles of Welded Wire Fabric

**Table A.16** Size and Pitch of Spirals

**Table A.1** Values of  $R_u$  and  $a/d$  for  $f'_c = 3000$  psi ( $\epsilon_t \geq 0.005$ ,  $\phi = 0.9$  and  $d = d_t$ )

100 $\rho$	$f_y = 40$ ksi		$f_y = 50$ ksi		$f_y = 60$ ksi		$f_y = 75$ ksi		
	$R_u$	$a/d$	$R_u$	$a/d$	$R_u$	$a/d$	$R_u$	$a/d$	
0.2	71	0.031	88	0.039	106	0.047	131	0.059	
0.3	105	0.047	131	0.059	156	0.071	192	0.089	
0.4	140	0.062	173	0.078	206	0.094	254	0.118	
0.5	173	0.078	214	0.098	254	0.118	310	0.148	
0.6	206	0.094	254	0.118	301	0.141	368	0.177	
0.7	238	0.110	293	0.138	347	0.165	421	0.207	
0.8	270	0.126	332	0.157	391	0.189	475	0.236	
0.9	301	0.142	369	0.177	434	0.213	524	0.266	
1.0	332	0.157	406	0.196	476	0.238	572	0.295	
1.1	362	0.173	441	0.216	517	0.260	620	0.325	
1.2	390	0.188	476	0.235	556	0.282	615	0.319	
1.3	420	0.204	510	0.255	594	0.306	$(\rho_{\max} = 1.082)$		
1.4	450	0.220	543	0.274	631	0.330			
1.5	476	0.236	575	0.294	667	0.353			
1.6	504	0.252	607	0.314	700	0.376			
1.7	530	0.267			615	0.319			
1.8	556	0.282			$(\rho_{\max} = 1.356)$				
1.9	582	0.298							
2.0	607	0.314							
2.1	630	0.330							
			615	0.319					
			$(\rho_{\max} = 1.624)$						
615		0.319							
$(\rho_{\max} = 2.031)$									

Note: Last values are the maximum for  $\epsilon_t = 0.005$ .

**Table A.2** Values of  $R_u$  and  $a/d$  for  $f'_c = 4000$  psi ( $\epsilon_t \geq 0.005$ ,  $\phi = 0.9$  and  $d = d_t$ )

100 $\rho$	$f_y = 40$ ksi		$f_y = 50$ ksi		$f_y = 60$ ksi		$f_y = 75$ ksi	
	$R_u$	$a/d$	$R_u$	$a/d$	$R_u$	$a/d$	$R_u$	$a/d$
0.2	71	0.024	89	0.029	106	0.035	132	0.044
0.3	106	0.036	132	0.044	158	0.053	194	0.066
0.4	140	0.047	175	0.059	208	0.071	257	0.088
0.5	175	0.059	217	0.074	258	0.089	317	0.110
0.6	208	0.071	260	0.088	307	0.106	378	0.132
0.7	242	0.083	300	0.103	355	0.123	434	0.154
0.8	274	0.094	340	0.118	400	0.141	490	0.176
0.9	307	0.106	378	0.132	447	0.158	545	0.198
1.0	340	0.118	419	0.147	492	0.176	600	0.220
1.1	370	0.130	455	0.161	536	0.194	650	0.242
1.2	400	0.141	492	0.176	580	0.212	702	0.264
1.3	432	0.153	530	0.191	620	0.230	752	0.286
1.4	462	0.165	565	0.206	662	0.247	801	0.308
1.5	492	0.177	600	0.221	700	0.265		
1.6	522	0.188	635	0.236	742	0.282	820	0.319 ( $\rho_{\max} = 1.445$ )
1.7	550	0.200	670	0.250	780	0.300		
1.8	580	0.212	702	0.265	818	0.318		
1.9	607	0.224	735	0.280				
2.0	635	0.236	768	0.294				
2.1	662	0.248	800	0.309				
2.2	690	0.260			820	0.319		
2.3	717	0.271				( $\rho_{\max} = 1.806$ )		
2.4	742	0.282						
2.5	767	0.294						
2.6	792	0.306						
2.7	817	0.318						
			820	0.319				
				( $\rho_{\max} = 2.167$ )				
	820	0.319						
		( $\rho_{\max} = 2.715$ )						

Note: Last values are the maximum for  $\epsilon_t = 0.005$ .



**Table A.3** Values of  $R_u$  and  $a/d$  for  $f'_c = 5000$  psi ( $\epsilon_t \geq 0.005$ ,  $\phi = 0.9$  and  $d = d_t$ )

100 $\rho$	$f_y = 40$ ksi		$f_y = 50$ ksi		$f_y = 60$ ksi		$f_y = 75$ ksi	
	$R_u$	$a/d$	$R_u$	$a/d$	$R_u$	$a/d$	$R_u$	$a/d$
0.2	71	0.019	89	0.024	106	0.028	132	0.035
0.3	106	0.029	133	0.036	159	0.042	196	0.052
0.4	141	0.038	176	0.047	210	0.056	260	0.070
0.5	176	0.047	218	0.060	260	0.070	322	0.088
0.6	210	0.056	260	0.071	310	0.085	384	0.106
0.7	244	0.066	302	0.083	360	0.100	442	0.123
0.8	277	0.075	343	0.094	408	0.113	500	0.141
0.9	310	0.085	383	0.106	455	0.127	556	0.159
1.0	343	0.094	424	0.118	502	0.141	612	0.177
1.1	375	0.104	463	0.130	550	0.155	667	0.195
1.2	408	0.113	500	0.141	593	0.169	722	0.212
1.3	440	0.123	540	0.153	637	0.183	776	0.230
1.4	470	0.132	578	0.165	681	0.198	830	0.247
1.5	502	0.141	615	0.177	724	0.212	875	0.265
1.6	532	0.150	652	0.188	766	0.226	920	0.282
1.7	563	0.160	688	0.200	808	0.240	970	0.300
1.8	593	0.169	724	0.212	848	0.254		
1.9	623	0.179	760	0.224	890	0.268	975	0.300
2.0	652	0.188	794	0.235	927	0.282	$(\rho_{\max} = 1.704)$	
2.1	681	0.198	830	0.247	965	0.292		
2.2	710	0.207	862	0.259	1003	0.311		
2.3	738	0.217	894	0.271				
2.4	766	0.226	927	0.282				
2.5	794	0.235	958	0.294				
2.6	821	0.244	990	0.306	975	0.300		
					$(\rho_{\max} = 2.123)$			
2.7	848	0.254						
2.8	875	0.263						
2.9	900	0.272						
3.0	127	0.282						
3.1	952	0.292						
			975	0.300				
			$(\rho_{\max} = 2.551)$					
	975	0.300						
	$(\rho_{\max} = 3.18)$							

Note: Last values are the maximum for  $\epsilon_t = 0.005$ .

**Table A.4** Values of  $\rho_{\max}$ ,  $R_{u,\max}$ ,  $\rho_b$ ,  $\rho_{\min}$

$$\rho_b = 0.85 \beta_1 (f'_c / f_y) [87 / (87 + f_y)] \quad \rho_{\max} = (0.003 + f_y / E_s) \rho_b / 0.008 \quad R_u = \phi \rho f_y [1 - \rho f_y / 1.7 f'_c]$$

$f'_c$ psi	$f_y = 40$ ksi				$f_y = 50$ ksi			
	$\rho_{\max}$	$R_{u,\max}$ psi	$\rho_b$	$\rho_{\min}$	$\rho_{\max}$	$R_{u,\max}$ psi	$\rho_b$	$\rho_{\min}$
3000	2.031	615	3.71	0.50	1.624	615	2.75	0.40
4000	2.715	820	4.96	0.50	2.167	820	3.67	0.40
5000	3.180	975	5.81	0.53	2.551	975	4.32	0.42
6000	3.575	1108	6.53	0.58	2.864	1108	4.85	0.47

$f'_c$ psi	$f_y = 60$ ksi				$f_y = 75$ ksi			
	$\rho_{\max}$	$R_{u,\max}$ psi	$\rho_b$	$\rho_{\min}$	$\rho_{\max}$	$R_{u,\max}$ psi	$\rho_b$	$\rho_{\min}$
3000	1.356	615	2.14	0.33	1.082	615	1.55	0.27
4000	1.806	820	2.85	0.33	1.445	820	2.07	0.27
5000	2.123	975	3.35	0.35	1.704	975	2.44	0.28
6000	2.389	1108	3.77	0.39	1.920	1108	2.75	0.31

Note:  $\rho_{\max}$  values are for  $\epsilon_t = 0.005$  and  $\phi = 0.9$ .

**Table A.5** Suggested Design Steel Ratios,  $\rho_s$ , and Comparison with Other Steel Ratios

$f'_c$ psi	$f_y$ ksi	$\rho_b$	$\rho_{\max}$	$\rho_s$	$R_u$ for $\rho_s$ (psi)	Ratio $\rho_s / \rho_b$	Ratio $\rho_s / \rho_{\max}$	Weight of $\rho_s$ (lb/ft <sup>3</sup> of concrete)
3000	40	3.71	2.031	1.4	450	0.377	0.689	7
	50	2.75	1.624	1.2	476	0.436	0.739	6
	60	2.15	1.356	1.2	556	0.558	0.885	6
4000	40	4.96	2.715	1.4	462	0.282	0.516	7
	50	3.67	2.167	1.4	565	0.381	0.646	7
	60	2.85	1.806	1.4	662	0.491	0.775	7
5000	40	5.81	3.180	1.6	532	0.275	0.503	8
	50	4.32	2.551	1.6	652	0.370	0.627	8
	60	3.35	2.123	1.6	766	0.478	0.754	8

Note:  $\rho_{\max}$  values are for  $\epsilon_t = 0.005$  and  $\phi = 0.9$ .

**Table A.6** Minimum Thickness of Beams and One-Way Slabs

Member	Yield Strength $f_y$ (ksi)	Simply Supported	One End Continuous	Both Ends Continuous	Cantilever
Solid one-way slabs	40	$L/25$	$L/30$	$L/35$	$L/12.5$
	50	$L/22$	$L/27$	$L/31$	$L/11$
	60	$L/20$	$L/24$	$L/8$	$L/10$
Beams or ribbed one-way slabs	40	$L/20$	$L/23$	$L/26$	$L/10$
	50	$L/18$	$L/20.5$	$L/23.5$	$L/9$
	60	$L/16$	$L/18.5$	$L/21$	$L/8$

**Table A.7** Minimum Beam Width (in.) (Using Stirrups)

Size of Bars	Number of Bars in Single Layer of Reinforcement							Add for Each Added Bar (in.)
	2	3	4	5	6	7	8	
No. 4	6.1	7.6	9.1	10.6	12.1	13.6	15.1	1.50
No. 5	6.3	7.9	9.6	11.2	12.8	14.4	16.1	1.63
No. 6	6.5	8.3	10.0	11.8	13.5	15.3	17.0	1.75
No. 7	6.7	8.6	10.5	12.4	14.2	16.1	18.0	1.88
No. 8	6.9	8.9	10.9	12.9	14.9	16.9	18.9	2.00
No. 9	7.3	9.5	11.8	14.0	16.3	18.6	20.8	2.26
No. 10	7.7	10.2	12.8	15.3	17.8	20.4	22.9	2.54
No. 11	8.0	10.8	13.7	16.5	19.3	22.1	24.9	2.82
No. 14	8.9	12.3	15.6	19.0	22.4	25.8	29.2	3.39
No. 18	10.5	15.0	19.5	24.0	28.6	33.1	37.6	4.51

**Table A.8** Values of  $bd^2$  (in.<sup>3</sup>) where  $bd^2 = \left[ \frac{M_u}{R_u} \left( \frac{\text{lb} \cdot \text{in.}}{\text{psi}} \right) \right]$ 

$d$ (in.)	Values of $b$ (in.)											
	6	7	8	9	10	11	12	13	14	15	16	20
4	96	112	128	144	160	176	192	208	224	240	256	320
4.5	122	142	162	182	202	223	244	264	284	305	325	405
5	150	175	200	225	250	275	300	325	350	375	400	500
5.5	182	212	242	273	303	333	364	394	424	455	485	605
6	216	252	288	324	360	396	432	468	504	540	576	720
6.5	255	297	340	382	425	467	510	552	595	637	680	850
7	294	343	392	441	490	539	588	637	686	735	784	980
8	384	448	512	576	640	704	768	832	896	960	1024	1280
9	486	567	648	729	810	891	972	1053	1134	1215	1296	1620
10	600	700	800	900	1000	1100	1200	1300	1400	1500	1600	2000
11	726	847	968	1089	1210	1331	1452	1573	1694	1815	1936	2420
12	864	1008	1152	1296	1440	1584	1728	1872	2016	2160	2304	2880
13	1014	1183	1352	1521	1690	1859	2028	2197	2366	2535	2704	3380
14	1176	1372	1568	1764	1960	2156	2352	2548	2744	2940	3136	3920
15	1350	1575	1800	2025	2250	2475	2700	2925	3150	3375	3600	4500
16	1536	1792	2048	2304	2560	2816	3072	3328	3584	3840	4096	5120
17	1734	2023	2312	2601	2890	3179	3468	3757	4046	4335	4624	5780
18	1944	2268	2592	2916	3240	3564	3888	4212	4536	4860	5184	6480
19	2166	2527	2888	3249	3610	3971	4332	4693	5054	5415	5776	7220
20	2400	2800	3200	3600	4000	4400	4800	5200	5600	6000	6400	8000
21	2646	3087	3528	3969	4410	4851	5292	5733	6174	6615	7056	8820
22	2904	3388	3872	4356	4840	5324	5808	6292	6776	7260	7744	9680
23	3174	3703	4232	4761	5290	5819	6348	6877	7406	7935	8464	10,580
24	3456	4032	4608	5184	5760	6336	6912	7488	8064	8640	9216	11,520
28	4704	5488	6272	7056	7840	8624	9408	10,192	10,976	11,760	12,544	15,680
30	5400	6300	7200	8100	9000	9900	10,800	11,700	12,600	13,500	14,400	18,000
34	6936	8092	9248	10,404	11,560	12,716	13,872	15,028	16,184	17,340	18,496	23,120
40	9600	11,200	12,800	14,400	16,000	17,600	19,200	20,800	22,400	24,000	25,600	32,000

**Table A.9** Rectangular Sections with Compression Steel Minimum Steel Percentage  $100(\rho - \rho')$  for Compression Steel to Yield
$$(\rho - \rho') \geq 0.85\beta_1 \frac{f'_c}{f_y} \times \frac{d'}{d} \times \frac{87}{87 - f_y} \quad (f'_c \text{ and } f_y \text{ in ksi})$$

$f'_c$ (psi)	$\beta_1$	$d'/d$	$f_y$			
			40 ksi	50 ksi	60 ksi	75 ksi
3000	0.85	0.10	1.00	1.02	1.16	2.09
4000	0.85	0.10	1.33	1.35	1.55	2.78
5000	0.80	0.10	1.57	1.59	1.81	3.27
6000	0.75	0.10	1.78	1.81	2.06	3.71
3000	0.85	0.12	1.20	1.22	1.39	2.51
4000	0.85	0.12	1.60	1.62	1.86	3.34
5000	0.80	0.12	1.88	1.91	2.17	3.92
6000	0.75	0.12	2.14	2.17	2.47	4.45
3000	0.85	0.15	1.50	1.53	1.74	3.14
4000	0.85	0.15	2.00	2.03	2.33	4.17
5000	0.80	0.15	2.36	2.39	2.72	4.91
6000	0.75	0.15	2.67	2.72	3.09	5.57

Note: Minimum  $(\rho - \rho')$  for any value of  $d'/d = 10 \times (d'/d) \times$  value shown in table with  $d'/d = 0.10$ .

**Table A.10** Modulus of Elasticity of Concrete,  $E_c$  (ksi)

Concrete Cylinder Strength ( $f'_c$ )	Unit Weight of Concrete (psi)				
	90	100	110	125	145
3000	1540	1800	2080	2520	3150
4000	1780	2090	2410	2920	3640
5000	1990	2330	2690	3260	4060
6000	2185	2560	2950	3580	4500
7000	2360	2760	3190	3870	4800
8000	2520	2950	3410	4130	5200

Note:  $E_c = 33W^{1.5}\sqrt{f'_c}$   
 $E_c = 57,000\sqrt{f'_c} = W = 145$  psf (normal - weight concrete)

**Table A.11(a)** Values of  $\ell_d/d_b$  for Various Values of  $f'_c$  and  $f_y$  (Tension Bars)

$f'_c$ (ksi)	$f_y = 40$ ksi				$f_y = 60$ ksi			
	$\leq$ No. 6 Bars		$\geq$ No. 7 Bars		$\leq$ No. 6 Bars		$\geq$ No. 7 Bars	
	Conditions Met	Others	Conditions Met	Others	Conditions Met	Others	Conditions Met	Others
3	29.3	43.9	36.6	54.8	43.9	65.8	54.8	82.2
4	25.3	38.0	31.7	47.5	38.0	57.0	47.5	71.2
5	22.7	34.0	28.3	42.5	34.0	51.0	42.5	63.7
6	20.7	31.0	25.9	38.8	31.0	46.5	38.8	58.1

**Table A.11(b)** Development Length  $\ell_d$  for Tension Bars and  $f_y = 60$  ksi ( $\psi_t = \psi_e = \lambda = 1$ )

Bar Number	Bar Diameter (in.)	Development Length $\ell_d$ (in.)—Tension Bars			
		$f'_c = 3$ ksi		$f'_c = 4$ ksi	
		Conditions Met	Others	Conditions Met	Others
3	0.375	17	25	15	21
4	0.500	22	33	19	29
5	0.625	28	41	24	36
6	0.750	33	50	29	43
7	0.875	48	72	42	63
8	1.000	55	83	48	72
9	1.128	62	93	54	81
10	1.270	70	105	61	92
11	1.410	78	116	68	102

**Table A.12** Designations, Areas, Perimeters, and Weights of Standard U.S. Bars

Bar No.	Diameter (in.)	Cross-Sectional Area (in. <sup>2</sup> )	Perimeter (in.)	Unit Weight per Foot (lb)	Diameter (mm)	Area (mm <sup>2</sup> )
2	$\frac{1}{4} = 0.250$	0.05	0.79	0.167	6.4	32
3	$\frac{3}{8} = 0.375$	0.11	1.18	0.376	9.5	71
4	$\frac{1}{2} = 0.500$	0.20	1.57	0.668	12.7	129
5	$\frac{5}{8} = 0.625$	0.31	1.96	1.043	15.9	200
6	$\frac{3}{4} = 0.750$	0.44	2.36	1.502	19.1	284
7	$\frac{7}{8} = 0.875$	0.60	2.75	2.044	22.2	387
8	1 = 1.000	0.79	3.14	2.670	25.4	510
9	$1\frac{1}{8} = 1.128$	1.00	3.54	3.400	28.7	645
10	$1\frac{1}{4} = 1.270$	1.27	3.99	4.303	32.3	820
11	$1\frac{3}{8} = 1.410$	1.56	4.43	5.313	35.8	1010
14	$1\frac{3}{4} = 1.693$	2.25	5.32	7.650	43.0	1450
18	$2\frac{1}{4} = 2.257$	4.00	7.09	13.600	57.3	2580

**Table A.13** Areas of Groups of Standard U.S. Bars in Square Inches

Bar Number	Number of Bars											
	1	2	3	4	5	6	7	8	9	10	11	12
3	0.11	0.22	0.33	0.44	0.55	0.66	0.77	0.88	1.00	1.10	1.21	1.32
4	0.20	0.39	0.58	0.78	0.98	1.18	1.37	1.57	1.77	1.96	2.16	2.36
5	0.31	0.61	0.91	1.23	1.53	1.84	2.15	2.45	2.76	3.07	3.37	3.68
6	0.44	0.88	1.32	1.77	2.21	2.65	3.09	3.53	3.98	4.42	4.84	5.30
7	0.60	1.20	1.80	2.41	3.01	3.61	4.21	4.81	5.41	6.01	6.61	7.22
8	0.79	1.57	2.35	3.14	3.93	4.71	5.50	6.28	7.07	7.85	8.64	9.43
9	1.00	2.00	3.00	4.00	5.00	6.00	7.00	8.00	9.00	10.00	11.00	12.00
10	1.27	2.53	3.79	5.06	6.33	7.59	8.86	10.16	11.39	12.66	13.92	15.19
11	1.56	3.12	4.68	6.25	7.81	9.37	10.94	12.50	14.06	15.62	17.19	18.75
14	2.25	4.50	6.75	9.00	11.25	13.50	15.75	18.00	20.25	22.50	24.75	27.00
18	4.00	8.00	12.00	16.00	20.00	24.00	28.00	32.00	36.00	40.00	44.00	48.00

**Table A.14** Areas of Bars in Slabs (Square Inches per Foot)

Spacing (in.)	Bar Number									
	3	4	5	6	7	8	9	10	11	
3	0.44	0.78	1.23	1.77	2.40	3.14	4.20	5.06	6.25	
3 $\frac{1}{2}$	0.38	0.67	1.05	1.51	2.06	2.69	3.43	4.34	5.36	
4	0.33	0.59	0.92	1.32	1.80	2.36	3.00	3.80	4.68	
4 $\frac{1}{2}$	0.29	0.52	0.82	1.18	1.60	2.09	2.67	3.37	4.17	
5	0.26	0.47	0.74	1.06	1.44	1.88	2.40	3.04	3.75	
5 $\frac{1}{2}$	0.24	0.43	0.67	0.96	1.31	1.71	2.18	2.76	3.41	
6	0.22	0.39	0.61	0.88	1.20	1.57	2.00	2.53	3.12	
6 $\frac{1}{2}$	0.20	0.36	0.57	0.82	1.11	1.45	1.85	2.34	2.89	
7	0.19	0.34	0.53	0.76	1.03	1.35	1.71	2.17	2.68	
7 $\frac{1}{2}$	0.18	0.31	0.49	0.71	0.96	1.26	1.60	2.02	2.50	
8	0.17	0.29	0.46	0.66	0.90	1.18	1.50	1.89	2.34	
9	0.15	0.26	0.41	0.59	0.80	1.05	1.33	1.69	2.08	
10	0.13	0.24	0.37	0.53	0.72	0.94	1.20	1.52	1.87	
12	0.11	0.20	0.31	0.44	0.60	0.79	1.00	1.27	1.56	

**Table A.15** Common Styles of Welded Wire Fabric

Style Designation	Steel Area (in. <sup>2</sup> ft)		Weight Approx. lb/100 ft <sup>2</sup>
	Longitudinal	Transverse	
6 × 6—W1.4 × W1.4	0.03	0.03	21
6 × 6—W2 × W2	0.04	0.04	29
6 × 6—W2.9 × W2.9	0.06	0.06	42
6 × 6—W4 × W4	0.08	0.08	58
6 × 6—W5.5 × W5.5	0.11	0.11	80
4 × 4—W1.4 × W1.4	0.04	0.04	31
4 × 4—W2 × W2	0.06	0.06	43
4 × 4—W2.9 × W2.9	0.09	0.09	62
4 × 4—W4 × W4	0.12	0.12	86

**Table A.16** Size and Pitch of Spirals

$f_y$ (ksi)	Diameter of Column (in.)	Outside to Outside of Spiral (in.)	$f'_c$ (psi)		
			3000	4000	5000
40	14, 15	11, 12	$\frac{3}{8} - 1\frac{3}{4}$	$\frac{1}{2} - 2\frac{1}{2}$	$\frac{1}{2} - 1\frac{3}{4}$
	16	13	$\frac{3}{8} - 1\frac{3}{4}$	$\frac{1}{2} - 2\frac{1}{2}$	$\frac{1}{2} - 2$
	17–19	14–16	$\frac{3}{8} - 1\frac{3}{4}$	$\frac{1}{2} - 2\frac{1}{2}$	$\frac{1}{2} - 2$
	20–23	17–20	$\frac{3}{8} - 1\frac{3}{4}$	$\frac{1}{2} - 2\frac{1}{2}$	$\frac{1}{2} - 2$
	24–30	21–27	$\frac{3}{8} - 2$	$\frac{1}{2} - 2\frac{1}{2}$	$\frac{1}{2} - 2$
60	14, 15	11, 12	$\frac{3}{8} - 2\frac{3}{4}$	$\frac{3}{8} - 2$	$\frac{1}{2} - 2\frac{3}{4}$
	16–23	13–20	$\frac{3}{8} - 2\frac{3}{4}$	$\frac{3}{8} - 2$	$\frac{1}{2} - 2\frac{3}{4}$
	24–29	21–26	$\frac{3}{8} - 3$	$\frac{3}{8} - 2\frac{1}{4}$	$\frac{1}{2} - 3$
	30	27	$\frac{3}{8} - 3$	$\frac{3}{8} - 2\frac{1}{4}$	$\frac{1}{2} - 3\frac{1}{4}$





# APPENDIX B

## DESIGN TABLES (SI UNITS)

**Table B.1** Values of  $R_u$  and  $\frac{a}{d}$  for  $f'_c = 21$  MPa ( $R_u$  in MPa)

**Table B.2** Values of  $R_u$  and  $\frac{a}{d}$  for  $f'_c = 28$  MPa ( $R_u$  in MPa)

**Table B.3** Values of  $R_u$  and  $\frac{a}{d}$  for  $f'_c = 35$  MPa ( $R_u$  in MPa)

**Table B.4** Values of  $\rho_{\max}$ ,  $R_{u, \max}$ ,  $\rho_b$ , and  $\rho_{\min}$

**Table B.5** Suggested Design Steel Ratios,  $\rho_s$ , and Comparison with Other Steel Ratios

**Table B.6** Minimum Thickness of Beams and One-Way Slabs

**Table B.7** Rectangular Sections with Compression Steel

**Table B.8** Modulus of Elasticity of Normal-Weight Concrete

**Table B.9** Development Length

**Table B.10** Designation, Areas, and Mass of Bars

**Table B.11** ASTM Standard Metric Reinforcing Bars

**Table B.12** Areas of Group of Bars ( $\text{mm}^2$ )—Metric

**Table B.1** Values of  $R_u$  and  $a/d$  for  $f'_c = 21$  MPa ( $R_u$  in MPa), ( $\epsilon_t \geq 0.005$ ,  $\phi = 0.9$  and  $d = d_t$ )

100 $\rho$	$f_y = 280$ MPa		$f_y = 350$ MPa		$f_y = 420$ MPa		$f_y = 520$ MPa	
	$R_u$	$a/d$	$R_u$	$a/d$	$R_u$	$a/d$	$R_u$	$a/d$
0.2	0.50	0.031	0.62	0.039	0.75	0.047	0.92	0.059
0.3	0.74	0.046	0.92	0.059	1.10	0.071	1.35	0.089
0.4	0.98	0.062	1.22	0.078	1.45	0.094	1.79	0.118
0.5	1.21	0.078	1.50	0.098	1.79	0.118	2.18	0.148
0.6	1.45	0.094	1.79	0.118	2.12	0.141	2.59	0.177
0.7	1.68	0.110	2.06	0.138	2.44	0.165	2.96	0.207
0.8	1.90	0.126	2.33	0.157	2.75	0.189	3.34	0.236
0.9	2.12	0.142	2.59	0.177	3.05	0.213	3.68	0.266
1.0	2.33	0.157	2.84	0.196	3.35	0.238	4.02	0.295
1.1	2.55	0.173	3.10	0.216	3.64	0.260	4.36	0.325
1.2	2.74	0.188	3.35	0.235	3.91	0.280	4.32	0.319
1.3	2.95	0.204	3.59	0.255	4.18	0.306	$(\rho_{\max} = 1.085)$	
1.4	3.16	0.220	3.82	0.274	4.44	0.330		
1.5	3.35	0.236	4.04	0.294				
1.6	3.54	0.252	4.27	0.314				
1.7	3.73	0.267			4.32	0.319		
1.8	3.91	0.282			$(\rho_{\max} = 1.37)$			
1.9	4.09	0.298						
2.0	4.27	0.314						
2.1	4.43	0.330	4.32	0.319				
				$(\rho_{\max} = 1.63)$				
4.32		0.319						
$(\rho_{\max} = 2.04)$								

Note: Last values are the maximum for  $\epsilon_t = 0.005$ .

**Table B.2** Values of  $R_u$  and  $a/d$  for  $f'_c = 28$  MPa ( $R_u$  in MPa), ( $\epsilon_t \geq 0.005$ ,  $\phi = 0.9$  and  $d = d_t$ )

100 $\rho$	$f_y = 280$ MPa		$f_y = 350$ MPa		$f_y = 420$ MPa		$f_y = 520$ MPa	
	$R_u$	$a/d$	$R_u$	$a/d$	$R_u$	$a/d$	$R_u$	$a/d$
0.2	0.50	0.024	0.63	0.029	0.75	0.025	0.93	0.044
0.3	0.74	0.036	0.93	0.044	1.11	0.053	1.36	0.066
0.4	0.98	0.047	1.23	0.059	1.46	0.071	1.81	0.088
0.5	1.23	0.059	1.53	0.074	1.81	0.089	2.23	0.110
0.6	1.46	0.071	1.83	0.088	2.16	0.106	2.66	0.132
0.7	1.70	0.083	2.11	0.103	2.50	0.123	3.05	0.154
0.8	1.93	0.094	2.39	0.118	2.81	0.141	3.45	0.176
0.9	2.16	0.106	2.66	0.132	2.14	0.158	3.83	0.198
1.0	2.39	0.118	2.95	0.147	3.46	0.176	4.22	0.220
1.1	2.60	0.130	3.20	0.161	3.77	0.194	4.57	0.242
1.2	2.81	0.141	3.46	0.176	4.08	0.212	4.94	0.264
1.3	3.04	0.153	3.73	0.191	4.36	0.230	5.29	0.286
1.4	3.25	0.165	3.97	0.206	4.65	0.247		
1.5	3.46	0.177	4.22	0.221	4.92	0.265		
1.6	3.67	0.188	4.46	0.236	5.22	0.282	5.77	0.319 ( $\rho_{\max} = 1.45$ )
1.7	3.87	0.200	4.71	0.250	5.48	0.300		
1.8	4.08	0.212	4.94	0.265	5.75	0.318		
1.9	4.27	0.224	5.17	0.280				
2.0	4.46	0.236	5.40	0.294				
2.1	4.65	0.248	5.62	0.309				
2.2	4.85	0.260			5.77	0.319		
2.3	5.04	0.271			( $\rho_{\max} = 1.82$ )			
2.4	5.22	0.282						
2.5	5.39	0.294						
2.6	5.57	0.306						
2.7	5.74	0.318						
2.8	5.92	0.330	5.77	0.319 ( $\rho_{\max} = 2.18$ )				
	5.77	0.319 ( $\rho_{\max} = 2.73$ )						

Note: Last values are the maximum for  $\epsilon_t = 0.005$ .

**Table B.3** Values of  $R_u$  and  $a/d$  for  $f'_c = 35$  MPa ( $R_u$  in MPa), ( $\epsilon_t \geq 0.005$ ,  $\phi = 0.9$  and  $d = d_t$ )

100 $\rho$	$f_y = 350$ MPa		$f_y = 420$ MPa		$f_y = 520$ MPa	
	$R_u$	$a/d$	$R_u$	$a/d$	$R_u$	$a/d$
0.2	0.63	0.024	0.75	0.028	0.93	0.035
0.3	0.93	0.036	1.12	0.042	1.38	0.052
0.4	1.24	0.047	1.48	0.056	1.83	0.070
0.5	1.53	0.060	1.83	0.070	2.26	0.088
0.6	1.83	0.071	2.18	0.085	2.70	0.106
0.7	2.12	0.083	2.53	0.100	3.11	0.123
0.8	2.41	0.094	2.87	0.113	3.52	0.141
0.9	2.69	0.106	3.20	0.127	3.91	0.159
1.0	2.98	0.118	3.53	0.141	4.30	0.177
1.1	3.26	0.130	3.87	0.155	4.69	0.195
1.2	3.52	0.141	4.17	0.169	5.08	0.212
1.3	3.80	0.153	4.48	0.183	5.46	0.230
1.4	4.06	0.165	4.79	0.198	5.84	0.247
1.5	4.32	0.177	5.09	0.212	6.15	0.265
1.6	4.58	0.188	5.39	0.226	6.47	0.282
1.7	4.84	0.200	5.68	0.240	6.82	0.300
1.8	5.09	0.212	5.96	0.254		
1.9	5.34	0.224	6.26	0.268	6.85	0.3192
2.0	5.58	0.235	6.52	0.282		( $\rho_{\max} = 1.71$ )
2.1	5.84	0.247	6.78	0.296		
2.2	6.06	0.259				
2.3	6.29	0.271				
2.4	6.52	0.282				
2.5	6.74	0.294				
			6.85	0.319		
				( $\rho_{\max} = 2.16$ )		
	6.85	0.319				
		( $\rho_{\max} = 2.57$ )				

Note: Last values are the maximum for  $\epsilon_t = 0.005$ .

**Table B.4** Values of  $\rho_{max}$ ,  $R_{u,max}$ ,  $\rho_b$ ,  $\rho_{min}$

$$\rho_b = 0.85\beta_1(f'_c/f_y)[87/(87+f_y)] \quad \rho_{max} = (0.003 + f_y/E_s)\rho_b/0.008 \quad R_u = \phi\rho f_y[1 - \rho f_y/1.7f'_c]$$

$f'_c$ MPa	$f_y = 280$ MPa				$f_y = 350$ MPa			
	100 $\rho_{max}$	$R_{u,max}$ MPa	100 $\rho_b$	100 $\rho_{min}$	100 $\rho_{max}$	$R_{u,max}$ MPa	100 $\rho_b$	100 $\rho_{min}$
21	2.031	4.32	3.71	0.50	1.624	4.32	2.75	0.40
28	2.715	5.77	4.96	0.50	2.167	5.77	3.67	0.40
35	3.180	6.85	5.81	0.53	2.551	6.85	4.32	0.42
42	3.575	7.78	6.53	0.58	2.864	7.78	4.85	0.47

$f'_c$ MPa	$f_y = 420$ MPa				$f_y = 525$ MPa			
	100 $\rho_{max}$	$R_{u,max}$ MPa	100 $\rho_b$	100 $\rho_{min}$	100 $\rho_{max}$	$R_{u,max}$ MPa	100 $\rho_b$	100 $\rho_{min}$
21	1.356	4.32	2.14	0.33	1.082	4.32	1.55	0.27
28	1.806	5.77	2.85	0.33	1.445	5.77	2.07	0.27
35	2.123	6.85	3.35	0.35	1.704	6.85	2.44	0.28
42	2.389	7.78	3.77	0.39	1.920	7.78	2.75	0.31

Note:  $\rho_{max}$  values are for  $\epsilon_t = 0.005$  and  $\phi = 0.9$ .

**Table B.5** Suggested Design Steel Ratios,  $\rho_s$ , and Comparison with Other Steel Ratios

$f'_c$ MPa	$f_y$ MPa	100 $\rho_b$	100 $\rho_{max}$	100 $\rho_s$	$R_u$ for $\rho_s$ (MPa)	Ratio $\rho_s/\rho_b$	Ratio $\rho_s/\rho_{max}$	Weight of $\rho_s$ (kg/m <sup>3</sup> of concrete)
21	280	3.71	2.04	1.4	3.16	0.377	0.689	112
	350	2.75	1.63	1.2	3.35	0.436	0.739	96
	420	2.15	1.37	1.2	3.91	0.558	0.885	96
28	280	4.96	2.73	1.4	3.25	0.282	0.516	112
	350	3.67	2.18	1.4	3.97	0.381	0.646	112
	420	2.85	1.81	1.4	4.65	0.491	0.775	112
35	280	5.81	3.20	1.6	3.72	0.275	0.503	128
	350	4.32	2.57	1.6	4.58	0.370	0.627	128
	420	3.35	2.16	1.6	5.39	0.478	0.754	128

Note:  $\rho_{max}$  values are for  $\epsilon_t = 0.005$  and  $\phi = 0.9$ .

**Table B.6** Minimum Thickness of Beams and One-Way Slabs

Member	Yield Strength $f_y$ (MPa)	Simply Supported	One End Continuous	Both Ends Continuous	Cantilever
	Solid one-way slabs	280	L/25	L/30	L/35
350		L/22	L/27	L/31	L/11
420		L/20	L/24	L/28	L/10
Beams or ribbed one-way slabs	280	L/20	L/23	L/26	L/10
	350	L/18	L/20.5	L/23.5	L/9
	420	L/16	L/18.5	L/21	L/8

**Table B.7** Rectangular Sections with Compression Steel. Minimum Steel Percentage 100 ( $\rho - \rho'$ ) for Compression Steel to Yield
$$(\rho - \rho') \geq 0.85\beta_1 \left( \frac{f'_c}{f_y} \right) \times \left( \frac{d'}{d} \right) \times \frac{600}{600 - f_y}, (f_y, f'_c \text{ in MPa})$$

$f'_c$ MPa	$\beta_1$	$d'/d$	$f_y$ 300 MPa	$f_y$ 400 MPa	$f_y$ 500 MPa
21	0.85	0.10	1.20	1.35	2.16
28	0.85	0.10	1.45	1.63	2.60
35	0.80	0.10	1.59	1.80	2.85
42	0.75	0.10	1.70	1.91	3.06
21	0.85	0.12	1.45	1.63	2.60
28	0.85	0.12	1.73	1.95	3.12
35	0.80	0.12	2.02	2.27	3.64
42	0.75	0.12	2.04	2.29	3.67
21	0.85	0.15	1.81	2.03	3.25
28	0.85	0.15	2.17	2.44	3.90
35	0.80	0.15	2.38	2.68	4.28
42	0.75	0.15	2.55	2.87	4.59

Note: Minimum ( $\rho - \rho'$ ) for any value of  $d'/d = 10 \times (d'/d) \times$  value shown in table with  $d'/d = 0.10$ .

**Table B.8** Modulus of Elasticity of Normal-Weight Concrete

General:  $E_c = 0.043W^{1.5}\sqrt{f'_c}$  MPa

For Normal-Weight Concrete,  $W = 2350 \text{ kg/m}^3$ :  $E_c = 4730\sqrt{f'_c}$  MPa

$f'_c$ MPa	$E_c$ (kN/mm <sup>2</sup> )
17.5	20.0
21.0	22.5
28.0	25.0
35.0	29.0
42.0	32.0
49.0	33.5
56.0	36.5

**Table B.9(a)** Values of  $\ell_d/d_b$  for Various Values of  $f'_c$  and  $f_y$ (Tension Bars)

$f'_c$ MPa	$f_y = 300 \text{ MPa}$				$f_y = 400 \text{ MPa}$			
	$\leq 20 \text{ M Bars}$		$\geq 25 \text{ M Bars}$		$\leq 20 \text{ M Bars}$		$\geq 25 \text{ M Bars}$	
	Conditions Met	Others	Conditions Met	Others	Conditions Met	Others	Conditions Met	Others
20	34.0	50.5	42.0	63.0	45.0	67.0	56.0	84.0
30	27.5	41.5	34.5	51.5	36.5	55.0	46.0	68.5
35	25.5	38.5	32.0	47.5	34.0	51.0	42.5	63.5
40	23.5	35.5	29.5	44.5	31.5	47.5	39.5	59.5

**Table B.9(b)** Development Length  $\ell_d/d_b$  for Tension Bars and  $f_y = 400$  MPa ( $\alpha = \beta = \lambda = 1.0$ )

Bar Number	Bar Diameter (mm)	Development Length $\ell_d/d_d$ (mm) – Tension Bars			
		$f'_c = 20$ MPa		$f'_c = 30$ MPa	
		Conditions Met	Others	Conditions Met	Others
10M	11.3	Ê510	Ê765	Ê415	Ê620
15M	16.0	Ê720	1080	Ê585	Ê875
20M	19.5	Ê880	1320	Ê710	1070
25M	25.2	1410	2120	1160	1740
30M	29.9	1675	2510	1375	2065
35M	35.7	2000	3000	1640	2465

**Table B.10** Designations, Areas, and Mass of Bars

Bar Number	Nominal Dimensions		
	Diameter (mm)	Area (mm <sup>2</sup> )	Mass (kg/m)
10	9.5	71	0.560
13	12.7	129	0.994
16	15.9	199	1.552
19	19.1	284	2.235
22	22.2	387	3.042
25	25.4	510	3.973
29	28.7	645	5.060
32	32.3	819	6.404
36	35.8	1006	7.907
43	43.0	1452	11.38
57	57.3	2581	20.24

ASTM A615 M Grade 300 is limited to sizes no. 10 through no. 19; otherwise, grades are 400 or 500 MPa. (These bars are soft conversion of no. 3 to no. 18 in U.S. customary units.)

**Table B.11** ASTM Standard Metric Reinforcing Bars

Bar-Size Designation (number)	Nominal Dimensions		
	Diameter (mm)	Area (mm <sup>2</sup> )	Mass (kg/m)
10M	11.3	100	0.785
15M	16.0	200	1.570
20M	19.5	300	2.355
25M	25.2	500	3.925
30M	29.9	700	5.495
35M	35.7	1000	7.850
45M	43.7	1500	11.775
55M	56.4	2500	19.625

ASTM A615M grade 300 is limited to size 10 M through 20 M; otherwise, grades are 400 or 500 MPa.

**Table B.12** Areas of Group of Bars (mm<sup>2</sup>)—Metric

Bar Number	Number of Bars									
	Metric	1	2	3	4	5	6	7	8	9
10	71	142	213	384	355	426	497	568	639	710
13	129	258	387	516	645	774	903	1032	1161	1290
16	199	398	597	796	995	1194	1393	1592	1791	1990
19	284	568	852	1136	1420	1704	1988	2272	2556	2840
22	387	774	1161	1548	1935	2322	2709	3096	3483	3870
25	510	1020	1530	2040	2550	3060	3570	4080	4590	5100
29	645	1290	1935	2580	3225	3870	4515	5160	5805	6450
32	819	1638	2457	3276	4095	4914	5733	6552	7371	8190
36	1006	2012	3018	4024	5030	6036	7042	8048	9054	10060



# STRUCTURAL AIDS

**Table C.1** Simple Beams (Cases 1–20)

**Table C.2** Cantilever Beams (Cases 21–24)

**Table C.3** Propped Beams (Cases 25–32)

**Table C.4** Fixed-End Beams (Cases 33–40)

**Table C.5** Moments in Two Unequal Spans and Values of the Coefficient  $K$  (Cases 1–3)

**Table C.6** Moments in Three Unequal Spans and Values of the Coefficient  $K$  (Cases 4–6)

**Table C.7** Maximum and Minimum Moments in Equal-Span Continuous Beams (Cases 7–8)

**Table C.8** Moments in Unequal-Span Continuous Beams Subjected to Unequal Loads (Case 9)

*Note:* SS stands for shearing force diagram. BD stands for bending moment diagram.

Bending moments are drawn on the tension sides of beams.

Moments, shearing forces, and deflections for any combination of loadings are obtained by superposition.

**Table C.1** Simple Beams ( $w = \text{Load/Unit Length}$ )

## 1. Uniform load:

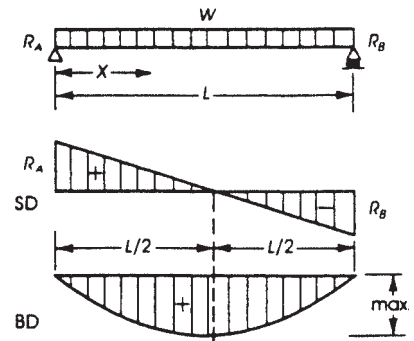
$$W = \text{total load} = wL$$

$$R_A = R_B = V_A = V_B = \frac{W}{2}$$

$$M_x = \frac{Wx}{2} \left(1 - \frac{x}{L}\right)$$

$$M_{\max} = \frac{WL}{8} \quad (\text{at center})$$

$$\Delta_{\max} = \frac{5}{384} \times \frac{WL^3}{EI} \quad (\text{at center})$$



## 2. Uniform partial load:

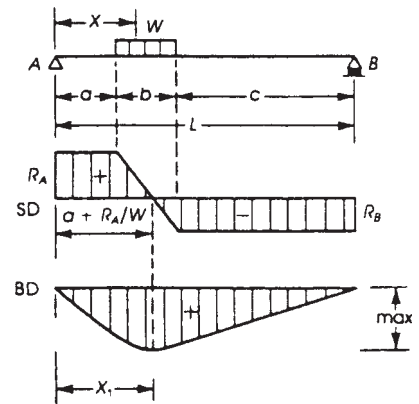
$$W = \text{total load} = wb$$

$$R_A = V_A = \frac{W}{L} \left(\frac{b}{2} + c\right)$$

$$R_B = V_B = \frac{W}{L} \left(\frac{b}{2} + a\right)$$

$$M_{\max} = \frac{W}{2b}(x^2 - a^2) \quad \text{when } x = a + \frac{R_A b}{W}$$

$$\Delta_{\max} = \frac{W}{384EI}(8L^3 - 4Lb^2 + b^3) \quad \text{when } a = c$$



## 3. Uniform partial load at one end:

$$W = \text{total load} = wa$$

$$R_A = V_A = W \left(1 - \frac{a}{2L}\right)$$

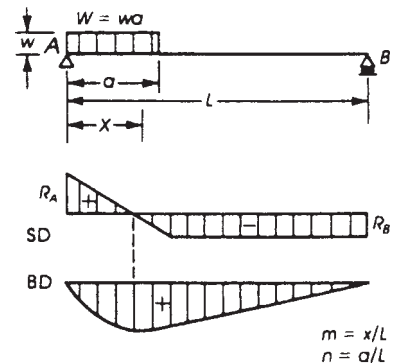
$$R_B = V_B = \frac{Wa}{2L}$$

$$M_{\max} = \frac{Wa}{2} \left(1 - \frac{a}{2L}\right)^2 \quad \text{when } x = a \left(1 - \frac{a}{2L}\right)$$

$$\Delta = \frac{WL^4}{24aEI} n^2 [2m^3 - 6m^2 + m(4 + n^2) - n^2]$$

$$\text{when } x \geq a$$

$$\Delta = \frac{WL^4 m}{24aEI} [n^2(2 - n)^2 - 2nm^2(2 - n) + m^3] \quad \text{when } x < a$$



(continued)

**Table C.1** (Continued)

4. Triangular load on span with maximum value at one end:

$$W = \text{total load} = \frac{wL}{2}$$

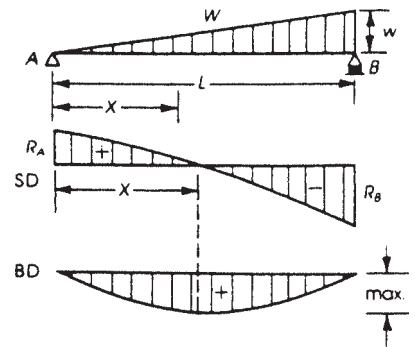
$$R_A = V_A = \frac{W}{3}$$

$$R_B = V_B = \frac{2W}{3}$$

$$M_x = \frac{Wx}{3} \left( 1 - \frac{x^2}{L^2} \right)$$

$$M_{\max} = 0.128WL \quad \text{when } x = 0.5774L$$

$$\Delta_{\max} = \frac{0.01304WL^3}{EI} \quad \text{when } x = 0.5193L$$



5. Triangular load with maximum value at midspan:

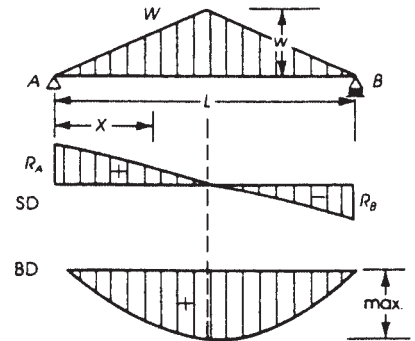
$$W = \text{total load} = \frac{wL}{2}$$

$$R_A = R_B = V_A = V_B = \frac{W}{2}$$

$$M_x = Wx \left( \frac{1}{2} - \frac{2x^2}{3L^2} \right)$$

$$M_{\max} = \frac{WL}{6} \quad (\text{at midspan})$$

$$\Delta_{\max} = \frac{WL^3}{60EI} \quad (\text{at midspan})$$



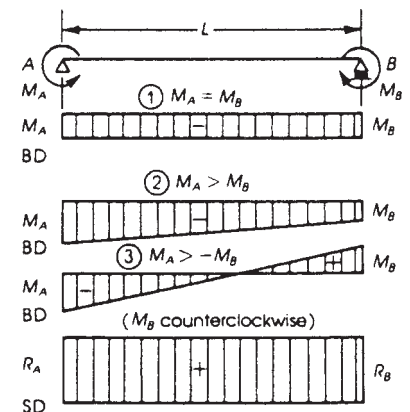
6. Moments at ends:

$$R_A = R_B = V_A = V_B = \frac{M_A - M_B}{L}$$

$$\Delta_{\max} (\text{at midspan}) = \frac{ML^2}{8EI} \quad \text{when } M_A = M_B$$

$$\Delta (\text{at midspan}) = \frac{M_A L^2}{16EI} \quad \text{when } M_B = 0$$

$$\Delta (\text{at midspan}) = \frac{M_B L^2}{16EI} \quad \text{when } M_A = 0$$



**Table C.1** (Continued)

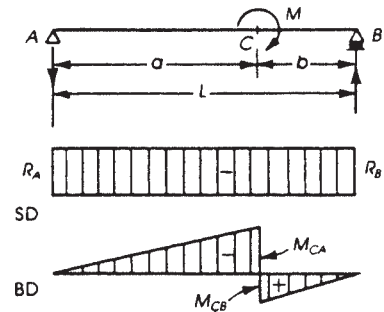
7. External moment at any point:

$$R_A = -R_B = V_A = V_B = \frac{M}{L}$$

$$M_{CA} = \frac{Ma}{L}$$

$$M_{CB} = \frac{Mb}{L}$$

$$\Delta_c = \frac{-Mab}{3EI}(a-b)$$

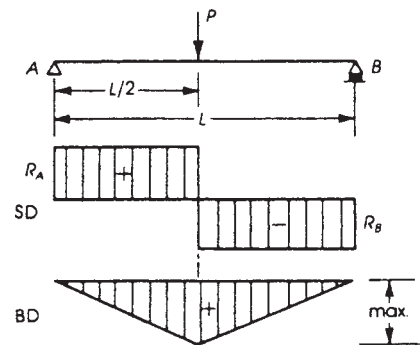


8. Concentrated load at midspan:

$$R_A = R_B = V_A = V_B = \frac{P}{2}$$

$$M_{\max} = \frac{PL}{4} \quad (\text{at midspan})$$

$$\Delta_{\max} = \frac{PL^3}{48EI} \quad (\text{at midspan})$$



9. Concentrated load at any point:

$$R_A = V_A = \frac{Pb}{L}$$

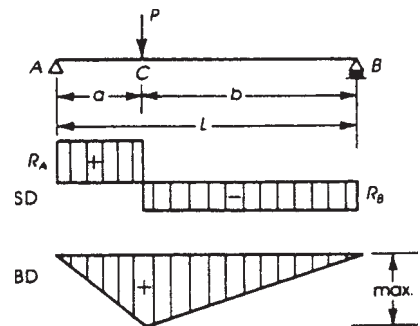
$$R_B = V_B = \frac{Pa}{L}$$

$$M_{\max} = \frac{Pab}{L} \quad (\text{at point load})$$

$$\Delta_c = \frac{Pa^2b^2}{3EI} \quad (\text{at point load})$$

$$\Delta_{\max} = \frac{PL^3}{48EI} \left[ \frac{3a}{L} - 4\left(\frac{a}{L}\right)^3 \right] \quad (\text{when } a \geq b)$$

$$\text{at } x = \sqrt{a(b+L)/3}$$



(continued)

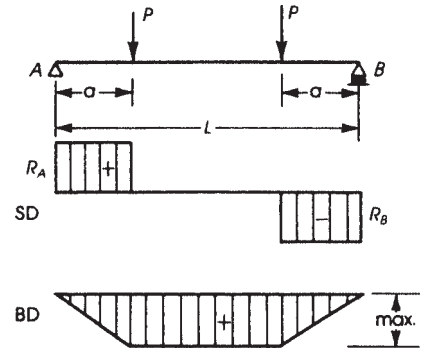
**Table C.1** (Continued)

10. Two symmetrical concentrated loads:

$$R_A = R_B = V_A = V_B = P$$

$$M_{\max} = Pa$$

$$\Delta_{\max} = \frac{PL^3}{6EI} \left[ \frac{3a}{4L} - \left( \frac{a}{L} \right)^3 \right] \quad (\text{at midspan})$$



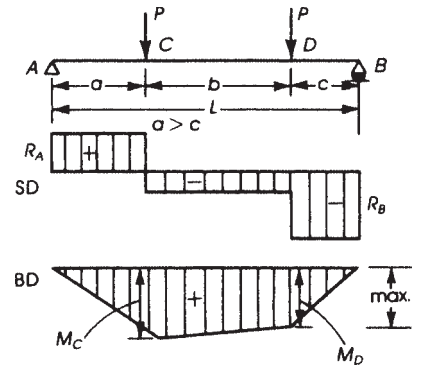
11. Two concentrated loads:

$$R_A = V_A = \frac{P(b+2c)}{L}$$

$$R_B = V_B = \frac{P(b+2a)}{L}$$

$$M_C = \frac{Pa(b+2c)}{L}$$

$$M_D = \frac{Pc(b+2a)}{L}$$



12. Two concentrated loads at one-third points:

$$R_A = R_B = V_A = V_B = P$$

$$M_{\max} = \frac{PL}{3}$$

$$\Delta_{\max} = \frac{23PL^3}{648EI} \quad (\text{at midspan})$$

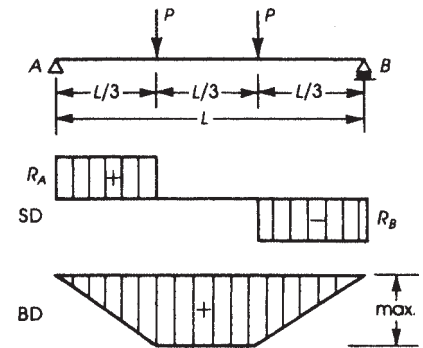


Table C.1 (Continued)

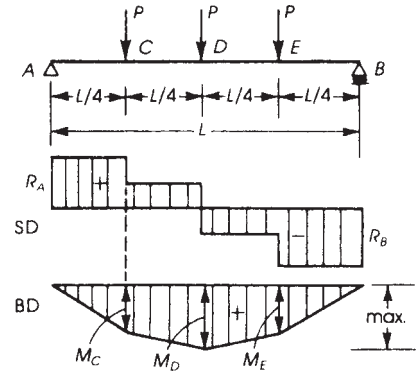
13. Three concentrated loads at one-fourth points:

$$R_A = R_B = V_A = V_B = \frac{3P}{2}$$

$$M_C = M_E = \frac{3PL}{8}$$

$$M_D = \frac{PL}{2}$$

$$\Delta_{\max} = \frac{19PL^3}{384EI} \quad (\text{at midspan})$$



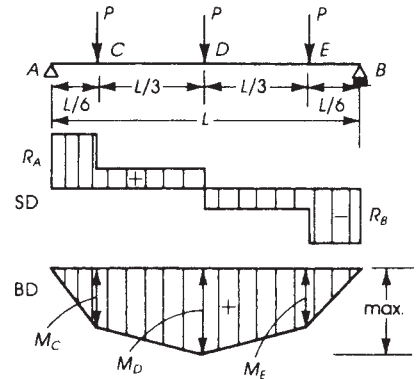
14. Three concentrated loads as shown:

$$R_A = R_B = V_A = V_B = \frac{3P}{2}$$

$$M_C = M_E = \frac{PL}{4}$$

$$M_D = \frac{5PL}{12}$$

$$\Delta_{\max} = \frac{53PL^3}{1296EI} \quad (\text{at midspan})$$



15. Uniformly distributed load and variable end moments:

$$W = \text{total load} = wL$$

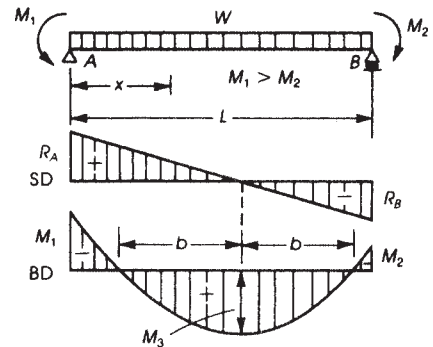
$$R_A = V_A = \frac{W}{2} + \frac{M_1 - M_2}{L}$$

$$R_B = V_B = \frac{W}{2} - \frac{M_1 - M_2}{L}$$

$$M_3 = \frac{WL}{8} - \frac{M_1 + M_2}{2} + \frac{(M_1 - M_2)^2}{2WL}$$

$$\text{at } x = \frac{L}{2} + \frac{M_1 - M_2}{W}$$

$$\Delta_x = \frac{Wx}{24EIL} \left[ x^3 - \left( 2L + \frac{4M_1}{W} - \frac{4M_2}{W} \right) x^2 + \frac{12M_1L}{W} x + L^3 - \frac{8M_1L^2}{W} - \frac{4M_2L^2}{W} \right]$$



(continued)

**Table C.1** (Continued)

16. Concentrated load at center and variable end moments:

$$R_A = V_A = \frac{P}{2} + \frac{M_1 - M_2}{L}$$

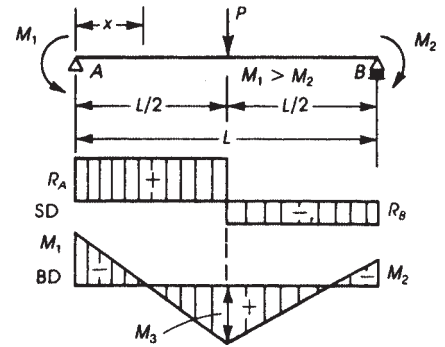
$$R_B = V_B = \frac{P}{2} - \frac{M_1 - M_2}{L}$$

$$M_3 = \frac{PL}{4} - \frac{M_1 + M_2}{2} \quad (\text{at midspan})$$

$$M_x = \left( \frac{P}{2} + \frac{M_1 - M_2}{L} \right) x - M_1 \quad \text{when } x < \frac{L}{2}$$

$$M_x = \frac{P}{2}(L - x) + \frac{(M_1 - M_2)}{L}x - M_1 \quad \text{when } x > \frac{L}{2}$$

$$\Delta_x = \frac{Px}{48EI} \left\{ 3L^2 - 4x^2 - \frac{8(L-x)}{PL} [M_1(2L-x) + M_2(L+x)] \right\} \quad \text{when } x < \frac{L}{2}$$



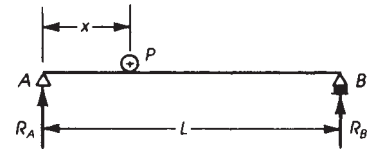
17. One concentrated moving load:

$$R_A \text{ max} = V_A \text{ max} = P \quad \text{at } x = 0$$

$$R_B \text{ max} = V_A \text{ max} = P \quad \text{at } x = L$$

$$M_{\text{max}} = \frac{PL}{4} \quad \text{at } x = \frac{L}{2}$$

$$M_x = \frac{P}{L}(L - x)x$$



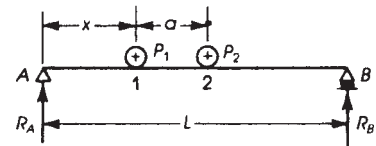
18. Two equal concentrated moving loads:

$$R_A \text{ max} = V_A \text{ max} = P \left( 2 - \frac{a}{L} \right) \quad \text{at } x = 0$$

$$M_{\text{max}} = \frac{P}{2L} \left( L - \frac{a}{2} \right)^2$$

$$\text{when } a < 0.586L \text{ under load 1 at } x = \frac{1}{2} \left( L - \frac{a}{2} \right).$$

$$M_{\text{max}} = \frac{PL}{4} \quad \text{when } a > 0.5L \text{ with one load at midspan.}$$



**Table C.1** (Continued)

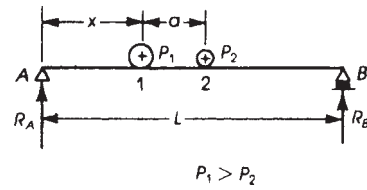
19. Two unequal concentrated moving loads:

$$R_A \max = V_A \max = P_1 + P_2 \left( \frac{L-a}{L} \right) \quad \text{at } x = 0$$

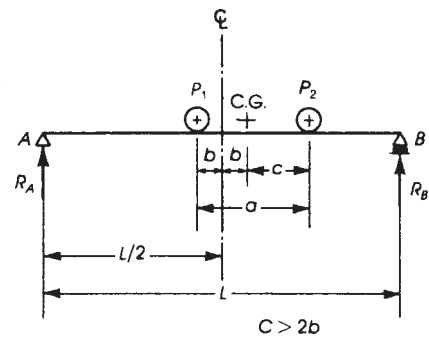
$$M_{\max} = (P_1 + P_2) \frac{x^2}{L}$$

$$\text{under load } P_1 \text{ at } x = \frac{1}{2} \left( L - \frac{P_2 a}{P_1 + P_2} \right)$$

$$M_{\max} = \frac{P_1 L}{4} \quad \text{may occur with larger load at center of span and other load off span}$$



20. General rules for simple beams carrying moving concentrated loads  $V_{\max}$  occurs at one support and other loads on span (trial method). For  $M_{\max}$ : place centerline of beam midway between center of gravity of loads and nearest concentrated load.  $M_{\max}$  occurs under this load (here  $P_1$ ).

**Table C.2** Cantilever Beams

21. Uniform load:

$$W = \text{total load} = wL$$

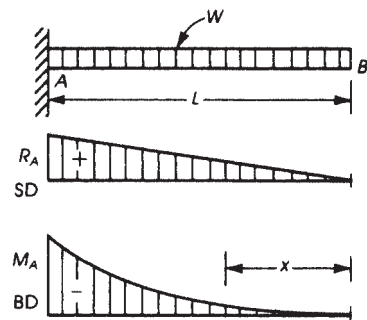
$$R_A = V_A = W$$

$$M_A = \frac{WL}{2} \quad (\text{at support } A)$$

$$M_x = \frac{Wx^2}{2L}$$

$$\Delta_B \max = \frac{WL^3}{8EI}$$

$$\Delta_x = \frac{W}{24EI} (x^4 - 4L^3x + 3L^4)$$



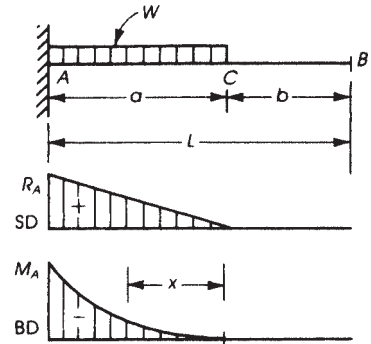
(continued)



**Table C.2** (Continued)

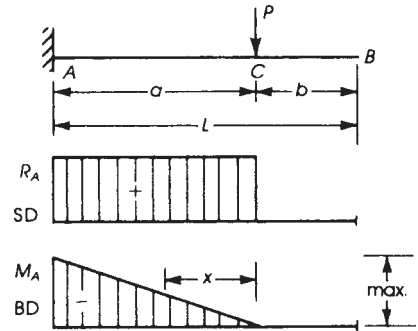
22. Partial uniform load starting from support:

$$\begin{aligned}
 W &= \text{total load} = wa \\
 R_A &= V_A = W \\
 M_A &= \frac{W a}{2} \quad (\text{at support } A) \\
 M_x &= \frac{W x^2}{2a} \\
 \Delta_C &= \frac{W a^3}{8EI} \\
 \Delta_B \text{max} &= \frac{W a^3}{8EI} \left( 1 + \frac{4b}{3a} \right)
 \end{aligned}$$



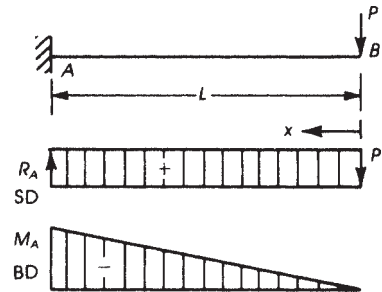
23. Concentrated load:

$$\begin{aligned}
 R_A &= V_A = P \\
 M_{\text{max}} &= P a \quad (\text{at support } A) \\
 M_x &= P x \\
 \Delta_C &= P a^3 / 3EI \\
 \Delta_B \text{max} &= \frac{P a^3}{3EI} \left( 1 + \frac{3b}{2a} \right) \quad (\text{at free end})
 \end{aligned}$$



24. Concentrated load at free end:

$$\begin{aligned}
 R_A &= V_A = P \\
 M_{\text{max}} &= P L \quad (\text{at } A) \\
 M_x &= P x \\
 \Delta_B \text{max} &= \frac{P L^3}{3EI} \\
 \Delta_x &= \frac{P}{6EI} (2L^3 - 3L^2 x + x^3)
 \end{aligned}$$



**Table C.3** Propped Beams

25. Uniform load:

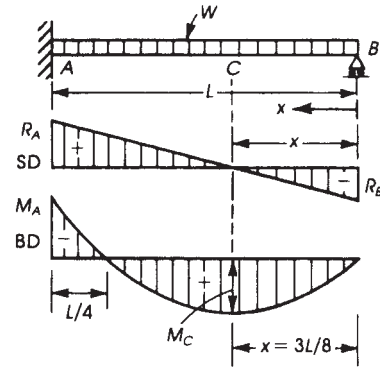
$$W = \text{total load} = wL$$

$$R_A = V_A = \frac{5W}{8} \quad R_B = V_B = \frac{3W}{8}$$

$$M_A = -\frac{WL}{8} \quad M_C = \frac{9WL}{128} \quad \left(\text{at } x = \frac{3}{8}L\right)$$

$$\Delta_x = \frac{WL^3}{48EI}(m - 3m^3 + 2m^4) \quad \text{where } m = \frac{x}{L}$$

$$\Delta_{\max} = \frac{WL^3}{185EI} \quad \text{at a distance } x = 0.4215L \text{ (from support B)}$$



26. Partial uniform load starting from hinged support:

$$W = wb \quad n = \frac{b}{L}$$

$$R_A = V_A = \frac{Wn}{8}(6 - n^2)$$

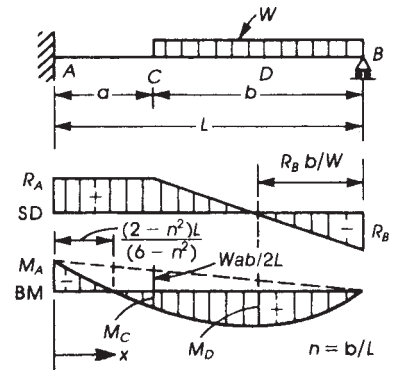
$$R_B = V_B = \frac{W}{8}(n^3 - 6n + 8)$$

$$M_A = -\frac{Wb}{8}(2 - n^2) \quad M_C = \frac{Wb}{8}(6n - n^3 - 4)$$

$$\Delta_x = \frac{WbL^2}{48EI}[(n^2 - 6)m^3 - (3n^2 - 6)m^2] \quad \text{when } x \leq a$$

$$\Delta_x = \frac{WL^4}{48bEI}[2P^4 - P^3n(n^3 - 6n + 8) + Pn^2(3n^2 - 8n + 6)] \quad \text{when}$$

$$x \geq a \text{ and } P = \frac{L-x}{L}$$



27. Partial uniform load starting from fixed end:

$$W = wa \quad n = \frac{a}{L}$$

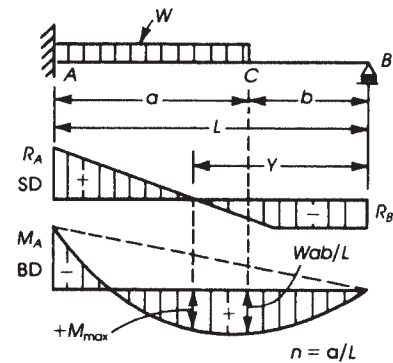
$$R_A = V_A = \frac{W}{8}[8 - n^2(4 - n)]$$

$$R_B = V_B = \frac{Wn^2}{8}(4 - n) \quad Y = b + an^2(4 - n)$$

$$M_A = -\frac{W_a}{8}(2 - n)^2$$

$$M_{\max} = \frac{Wa}{8} \left\{ -\frac{[8 - n^2(4 - n)]^2}{16} + 4 - n(4 - n) \right\}$$

$$\Delta_C = \frac{Wa^3}{48EI}(6 - 12n + 7n^2 - n^3)$$



(continued)

**Table C.3** (Continued)

28. Triangular load on all span  $L$ :

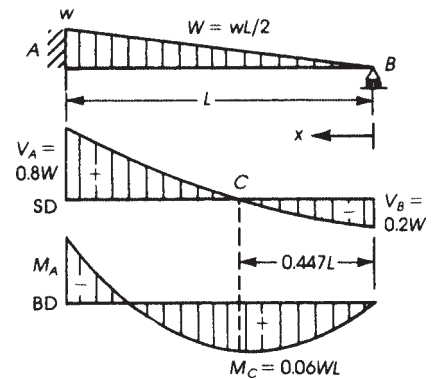
$$W = \text{total load} = \frac{wL}{2}$$

$$R_A = V_A = \frac{4}{5}W \quad R_B = \frac{W}{5} = V_B$$

$$M_A = -\frac{2}{15}WL$$

$$M_C = +\frac{3}{50}WL$$

$$\Delta_{\max} = \frac{WL^3}{212EI} \quad (\text{at } x = 0.447L)$$



29. Triangular load on part of the span:

$$W = \frac{wa}{2}$$

$$R_B = V_B = \frac{Wa^2}{20L^3}(5L - a)$$

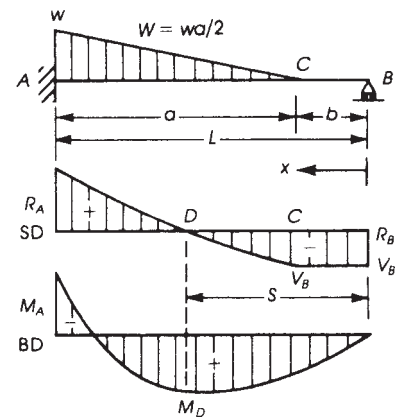
$$R_A = W - R_B$$

$$M_A = \frac{Wa}{60L^2}(3a^2 - 15aL + 20L^2)$$

Maximum positive moment at  $S = b + \frac{a^2}{2L}\sqrt{1 - \frac{a}{5L}}$

$$M_{\max}(\text{positive at } D) :$$

$$M_D = R_B S - \frac{WL}{3a^3}(-b + S)^3$$



30. Concentrated load at midspan:

$$R_A = V_A = \frac{11P}{16}$$

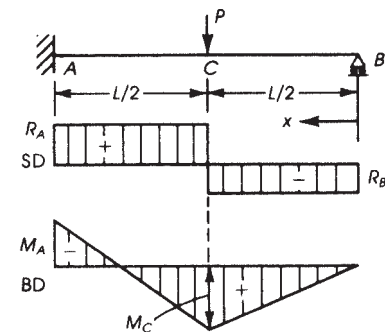
$$R_B = V_B = \frac{5P}{16}$$

$$M_A = -\frac{3PL}{16}$$

$$M_C = \frac{5PL}{32}$$

$$\Delta_C = \frac{7PL^3}{768EI}$$

$$\Delta_{\max} = \frac{PL^3}{107EI} \quad (\text{at } x = 0.447L \text{ from } B)$$



**Table C.3** (Continued)

31. Concentrated load at any point:

$$R_A = V_A = P - R_B \quad R_B = V_B = \frac{Pa^2}{2L^3}(b + 2L)$$

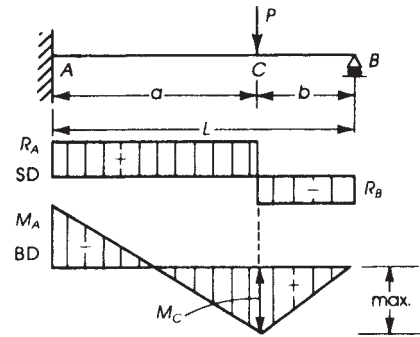
$$M_A = -\frac{Pb(L^2 - b^2)}{2L^2}$$

$$M_{A \text{ max}} = 0.193PL \quad \text{when } b = 0.577L$$

$$M_C = \frac{Pb}{2} \left( 2 - \frac{3b}{L} + \frac{b^3}{L^3} \right)$$

$$M_{C \text{ max}} = 0.174PL \quad \text{when } b = 0.366L$$

$$\Delta_C = \frac{Pa^3b^2}{12EI L^3}(4L - a)$$



32. Two concentrated loads at one-third points:

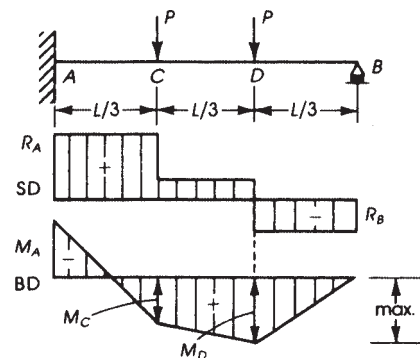
$$R_A = V_A = \frac{4P}{3}$$

$$R_B = V_B = \frac{2P}{3}$$

$$M_A = -\frac{PL}{3}$$

$$M_C = \frac{PL}{9} \quad M_D = \frac{2PL}{9}$$

$$\Delta_{\text{max}} = \frac{PL^3}{65.8EI}$$

occurs at point =  $0.423L$  from support  $B$ 

**Table C.4** Fixed-End Beams

## 33. Uniform load:

$$W = \text{total load} = wL$$

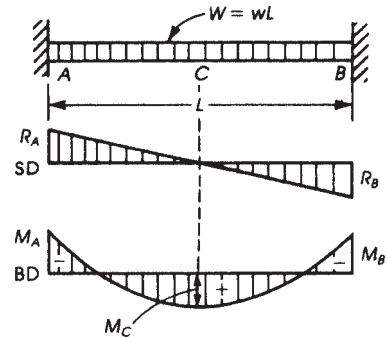
$$R_A = V_A = R_B = V_B = \frac{W}{2}$$

$$M_A = M_B = -\frac{WL}{12} \quad (\text{at support})$$

$$M_C \text{ max} = \frac{WL}{24} \quad (\text{at midspan})$$

$$\Delta_{\text{max}} = \frac{WL^3}{384EI} \quad (\text{at midspan})$$

$$\Delta_x = \frac{Wx^3}{24EI}(L-x)^2 \quad (\text{from A or B})$$



## 34. Uniform partial load at one end:

$$W = \text{total load} = wa \quad m = \frac{a}{L}$$

$$R_A = V_A = \frac{W(m^3 - 2m^2 + 2)}{2}$$

$$R_B = V_B = \frac{Wm^2(2-m)}{2} = W - R_A$$

$$M_A = \frac{WLm}{12}(3m^2 - 8m + 6)$$

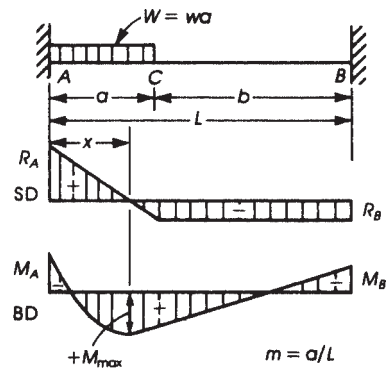
$$M_B = \frac{WLm^2}{12}(4 - 3m)$$

$$M_{\text{max}} = \frac{WLm^2}{12} \left( -\frac{3}{2}m^5 + 6m^4 - 6m^3 - 6m^2 + 15m - 8 \right)$$

$$\text{when } x = \frac{a}{2}(m^3 - 2m^2 + 2)$$

$$\Delta_{\text{max}} = \frac{WL^3}{333EI}$$

$$\Delta_C = \frac{WL^3}{384EI}$$



**Table C.4** (Continued)

35. Triangular load:

$$W = \frac{wL}{2}$$

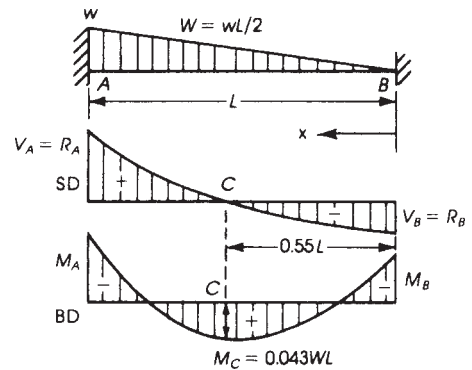
$$R_A = V_A = 0.7W$$

$$R_B = V_B = 0.3W$$

$$M_A = \frac{WL}{10} \quad M_B = \frac{WL}{15}$$

$$\Delta_{\max} = \frac{WL^3}{382EI} \quad (\text{at } x = 0.55L \text{ from } B)$$

$$M_C(\text{maximum positive moment}) = +\frac{WL}{23.3} \quad (\text{at } 0.55L \text{ from } B)$$



36. Triangular load on part of the span:

$$W = \frac{wa}{2}$$

$$R_B = V_B = \frac{Wa^2}{10L^3}(5L - 2a)$$

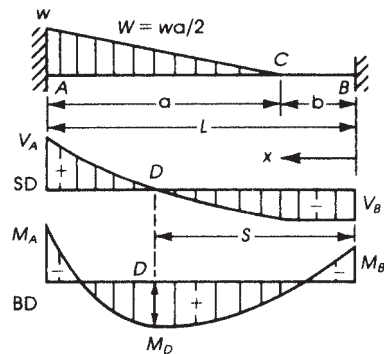
$$R_A = W - R_B$$

$$M_A = \frac{Wa}{30L^2}(3a^2 + 10bL)$$

$$M_B = \frac{Wa}{30L^2}(-3a^2 + 5aL)$$

$$\text{Maximum positive moment at } S = b + \frac{a^2}{3.16L} \sqrt{5 - \frac{2a}{L}}$$

$$M_D = R_B S - \frac{WL}{3a^3}(a + S - L)^3 - M_B$$



37. Triangular load, maximum intensity at midspan:

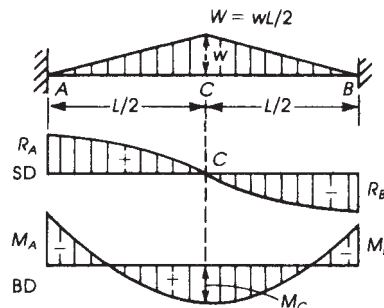
$$W = \text{total load} = \frac{wL}{2}$$

$$R_A = R_B = \frac{W}{2}$$

$$M_A = M_B = -\frac{5}{48}WL$$

$$M_C(\text{maximum positive}) = \frac{WL}{16}$$

$$\Delta_{\max} = \frac{1.4WL^3}{384EI} \quad (\text{at midspan})$$



(continued)

**Table C.4** (Continued)

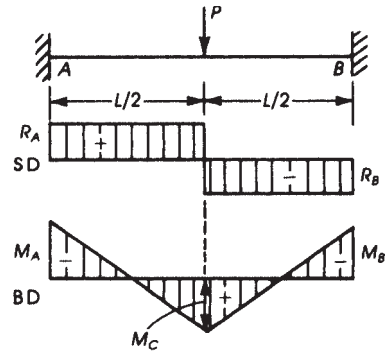
38. Concentrated load at midspan:

$$R_A = V_A = R_B = V_B = \frac{P}{2}$$

$$M_A = M_B = M_C = -\frac{PL}{8}$$

$$\Delta_{\max} = \frac{PL^3}{192EI} \quad (\text{at midspan})$$

$$\Delta_x = \frac{Px^2}{48EI}(3L - 4x) \quad \left(x < \frac{L}{2}\right)$$



39. Two symmetrical concentrated loads:

$$R_A = V_A = R_B = V_B = P$$

$$M_A = M_B = -\frac{Pa(L-a)}{L}$$

$$M_C = M_D = \frac{Pa^2}{L}$$

$$\Delta_{\max} = \frac{PL^3}{6EI} \left[ \frac{3a^2}{4L^2} - \left(\frac{a}{L}\right)^3 \right] \quad (\text{at midspan})$$

$$\text{If } a = \frac{L}{3},$$

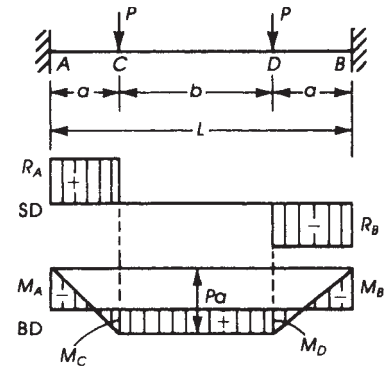
$$M_A = M_B = \frac{2}{9}PL$$

$$\Delta_{\max} = \frac{5PL^3}{648EI} \quad (\text{at centerline})$$

$$\text{If } a = \frac{L}{4},$$

$$M_A = M_B = \frac{3}{16}PL$$

$$\Delta_{\max} = \frac{PL^3}{192EI} \quad (\text{at centerline})$$



**Table C.4** (Continued)

40. Concentrated load at any point:

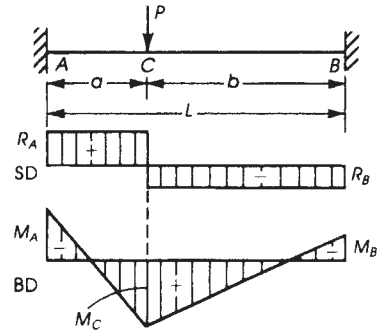
$$R_A = V_A = P \left( \frac{b}{L} \right)^2 \left( 1 + \frac{2a}{L} \right)$$

$$R_B = V_B = P \left( \frac{a}{L} \right)^2 \left( 1 + \frac{2b}{L} \right)$$

$$M_A = -\frac{Pab^2}{L^2} \quad M_B = -\frac{Pba^2}{L^2} \quad M_C = \frac{2Pa^2b^2}{L^3}$$

$$\Delta_C = \frac{Pa^3b^3}{3EI L^3} \quad (\text{at point } C)$$

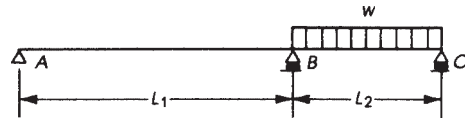
$$\Delta_{\max} = \frac{2Pa^2b^3}{3EI(3L - 2a)^2} \quad \text{when } x = \frac{2bL}{3L - 2a} \quad \text{and } b > a$$



**Table C.5** Moments in Two Unequal Spans and Values of the Coefficient  $K$  ( $w = \text{Unit Load/Unit Length}$ )

1. Load on short span:

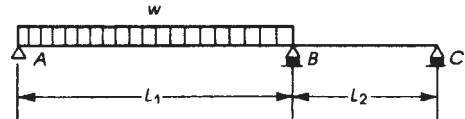
$$M_B = \frac{wL_2^3}{8(L_1 + L_2)} = \frac{wL_2^2}{K}$$



$L_2/L_1$	0.20	0.25	0.30	0.40	0.50	0.60	0.70	0.80	0.90	1.00
$K$	46.0	40.0	34.7	28.0	24.0	21.4	19.5	18.0	16.9	15.9

2. Load on long span:

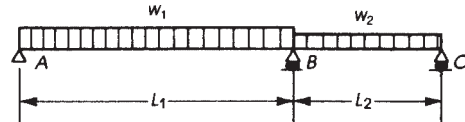
$$M_B = \frac{wL_1^3}{8(L_1 + L_2)} = \frac{wL_1^2}{K}$$



$L_2/L_1$	0.20	0.25	0.30	0.40	0.50	0.60	0.70	0.80	0.90	1.00
$K$	9.6	10.0	10.4	11.2	12.0	12.8	13.6	14.4	15.2	15.9

3. Both spans loaded with  $w_1$  on  $L_1$  and  $w_2$  on  $L_2$ :

$$M_B = \frac{w_1L_1^3 + w_2L_2^3}{8(L_1 + L_2)}$$

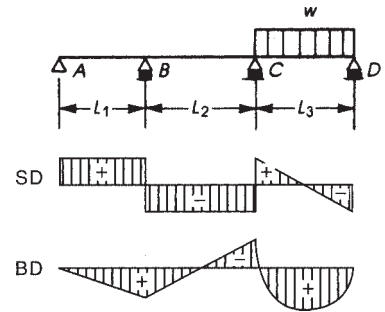




**Table C.6** Moments in Three Unequal Spans and Values of the Coefficient  $K$  ( $w$  = Load/Unit Length)

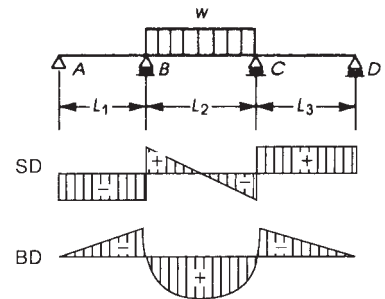
4. Load on span  $CD$ :

$L_2/L_3$	$M_B = \frac{wL_3^2}{K}$ (positive)	$M_C = \frac{wL_3^2}{K}$ (negative)
0.25	100.0	9.9
0.30	90.9	10.3
0.40	76.3	11.0
0.50	70.4	11.7
0.60	65.8	12.3
0.70	62.9	13.0
0.80	61.7	13.7
1.00	59.9	14.9



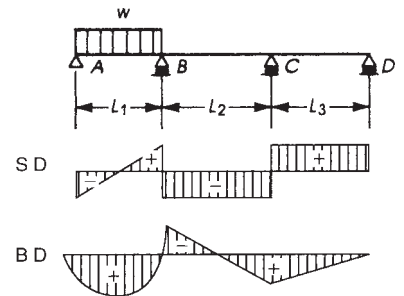
5. Load on middle span:

$L_2/L_1$	$M_B = M_C = \frac{wL_2^2}{K}$ (negative)
0.25	43.5
0.30	38.5
0.40	32.3
0.50	27.8
0.60	25.6
0.70	23.3
0.80	22.2
1.00	20.0



6. Load on span  $AB$ :

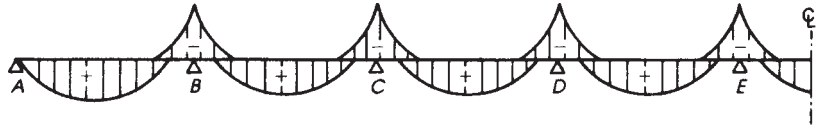
$L_2/L_1$	$M_B = \frac{wL_1^2}{K}$ (negative)	$M_C = \frac{wL_1^2}{K}$ (positive)
0.25	9.9	100.0
0.30	10.3	90.9
0.40	11.0	76.3
0.50	11.7	70.4
0.60	12.3	65.8
0.70	13.0	62.9
0.80	13.7	61.7
1.00	14.9	59.9



**Table C.7** Maximum and Minimum Moments in Equal-Span Continuous Beams

7. Uniform loads:

$$M = \frac{wL^2}{K}$$



where  $w = (\text{D.L.} + \text{L.L.})$   
per unit length

D.L. = Uniform dead load

L.L. = Uniform live load

Values of coefficient  $K$

Ratio $DL/w$	First span AB (positive moment)				Second support B (negative moment)			
	Number of spans				Number of spans			
	2	3	4	5	2	3	4	5
0.0	10.5	10.0	10.2	10.1	8.0	8.6	8.3	8.3
0.1	10.8	10.2	10.4	10.3	8.0	8.7	8.4	8.5
0.2	11.1	10.4	10.6	10.6	8.0	8.8	8.5	8.6
0.3	11.4	10.6	10.9	10.8	8.0	9.0	8.6	8.7
0.4	11.8	10.9	11.1	11.0	8.0	9.1	8.6	8.8
0.5	12.1	11.1	11.4	11.3	8.0	9.2	8.8	8.9
0.6	12.5	11.4	11.7	11.6	8.0	9.4	8.9	9.0
0.7	12.9	11.6	12.0	11.9	8.0	9.5	9.0	9.1
0.8	13.3	11.9	12.3	12.2	8.0	9.7	9.1	9.2
0.9	12.8	12.2	12.6	12.5	8.0	9.8	9.2	9.4
1.0	14.3	12.5	13.0	12.8	8.0	9.9	9.3	9.5

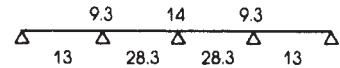
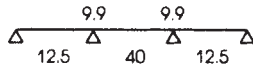
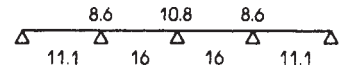
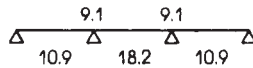
Ratio $DL/w$	Second span BC (positive moment)			Third support C (negative moment)		Third span CD (positive moment)	Interior span (positive moment)	Interior support (negative moment)
	Number of spans			Spans		Span		
	3	4	5	4	5	5		
0.0	13.4	12.4	12.7	9.3	9.0	11.7	12.0	8.8
0.1	14.3	13.2	13.5	9.7	9.3	12.3	12.6	9.1
0.2	15.4	14.0	14.3	10.0	9.6	12.9	13.3	9.8
0.3	16.7	14.9	15.3	10.4	9.9	13.6	14.1	9.5
0.4	18.2	16.0	16.5	10.8	10.2	14.3	15.0	9.9
0.5	20.0	17.2	17.9	11.5	10.5	15.2	16.0	10.1
0.6	22.2	18.7	19.5	11.7	10.9	16.2	17.2	10.5
0.7	25.0	20.4	21.4	12.2	11.3	17.3	18.4	10.8
0.8	28.6	22.4	23.8	12.7	11.7	18.5	20.0	11.2
0.9	33.3	24.9	26.6	13.3	12.2	20.0	21.8	11.6
1.0	40.0	28.3	30.0	14.0	12.7	21.7	24.0	12.0

(continued)

**Table C.7** (Continued)

Example:  $K$  values

1.  $\frac{DL}{w} = 0.4$
2.  $\frac{DL}{w} = 1.0$

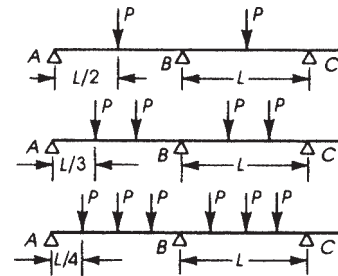


8. Concentrated loads:

$P'$  = concentrated dead load

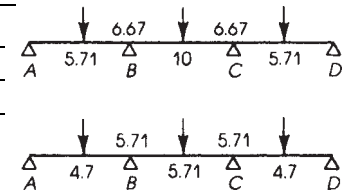
$P''$  = concentrated live load

$$M = \left( \frac{P'}{K_1} + \frac{P''}{K_2} \right) L$$



Number of Spans	First Span AB						Second Support B					
	$K_1$ (DL)			$K_2$ (LL)			$K_1$ (DL)			$K_2$ (LL)		
	2	3	4	2	3	4	2	3	4	2	3	4
Central load	6.40	5.71	5.89	4.92	4.70	4.76	5.35	6.67	6.22	5.33	5.71	5.53
One-third-point loads	4.50	4.09	4.20	3.60	3.46	3.50	3.00	3.75	3.50	3.00	3.21	3.11
One-fourth-point loads	3.67	3.20	3.34	2.61	2.46	2.50	2.13	2.67	2.49	2.13	2.28	2.21

Number of Spans	Second Span BC				Third Support C	
	$K_1$		$K_2$		$K_1$	$K_2$
	3	4	3	4	4	4
Central load	10.00	8.61	5.71	5.46	9.33	6.22
One-third-point loads	15.00	9.00	5.00	4.50	5.25	3.50
One-fourth-point loads	8.00	6.05	3.20	3.01	3.72	2.49



Example:  $K$  values

$K_1$ (dead load)  $M_{AB}(\max) = \left( \frac{P'}{5.71} + \frac{P''}{4.7} \right) L$

$-M_B(\max) = \left( \frac{P'}{6.67} + \frac{P''}{5.71} \right) L$

$K_2$ (live load)  $M_{BC}(\max) = \left( \frac{P'}{10} + \frac{P''}{5.71} \right) L$

**Table C.8** Moments in Unequal-Span Continuous Beams Subjected to Unequal Loads

9. Unequal spans and unequal loads. For approximate bending moments in continuous beams, use

$L' = 0.8L$  for spans continuous at both ends

$L' = L$  for spans continuous at only one end

1. Uniform loads (load on two adjacent spans):

$$M_B = \frac{w_1 L_1'^3 + w_2 L_2'^3}{8.5(L_1' + L_2')}$$

2. Concentrated loads:

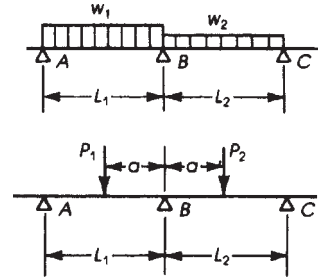
$$M_B = \frac{K P_1 L_1'^2}{L_1' + L_2'} \text{ due to load } P_1$$

$$M_B = \frac{K P_2 L_2'^2}{L_1' + L_2'} \text{ due to load } P_2$$

$a/L$	0.1	0.2	0.3	0.4	0.5	0.6	0.7	0.8	0.9	1.0
$K$	0.080	0.136	0.168	0.182	0.176	0.158	0.128	0.090	0.050	0.000

3. Moments within span:

- Maximum positive moment is obtained by superposing BM due to DL + LL and the negative moments at supports due to DL only.
- Maximum negative moment is obtained by superposing BM due to DL only and the negative moments at supports due to DL + LL

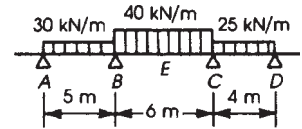


Example:

$$M_B = - \frac{30(0.8 \times 5)^3 + 40(0.8 \times 6)^3}{8.5(0.8 \times 5 + 0.8 \times 6)} = -84.8 \text{ kN}\cdot\text{m}$$

$$M_C = - \frac{40(0.8 \times 6)^3 + 25(0.8 \times 4)^3}{8.5(0.8 \times 4 + 0.8 \times 6)} = -77.1 \text{ kN}\cdot\text{m}$$

$$M_E = (\text{at centerline of } BC) = + \frac{wL^2}{8} + \frac{1}{2} (M_B + M_C) = \frac{40 \times 36}{8} + \frac{1}{2} (-84.8 - 77.1) = +99 \text{ kN}\cdot\text{m}$$





# INDEX

## A

AASHTO, 4, 7  
AASHTO model, 45  
    creep calculation, 47  
    shrinkage calculation, 46  
ACI Code, 3, 4  
    design concept, 4  
    system of units, 5  
ACI 209 model, 27  
    creep calculation, 29  
    shrinkage calculation, 27  
Active soil pressure, 493  
Admixtures, 25  
Aggregates, 15, 69, 70  
    maximum size, 69  
Alignment charts, 422  
ANSI, 6  
Areas of reinforcing bars, 73, 75  
ASTM, 4, 16, 73, 74  
Axial compression, 194, 358  
Axial tension, 195, 402

## B

Balanced section, 88  
B3 model, 30  
    creep calculation, 33  
    shrinkage calculation, 30  
Balanced strain condition, 88, 99

Bar cutoff, 281  
Bar dimensions and weights, 75  
Bar grades, 73, 74  
Bars, areas, 1001, 1010  
    English units, 10  
    metric units, 10  
Bars, bundles, 113, 157, 266, 276  
Beams, 83, 152  
    analysis, 84  
    balanced, 88  
    compression reinforcement, 116  
    compressive stress distribution, 84  
    control of cracking, 226  
    cracking moment, 228  
    curved, 858  
    doubly reinforced, 116, 119, 162  
    I-section, 127  
    irregular shapes, 137  
    maximum steel ratio, 101, 114, 157  
    minimum overall depth, 157  
    minimum steel ratio, 109, 112  
    neutral axis, 84, 87, 94, 105, 119,  
        163  
    shallow, 199  
    shear and diagonal tension, 188  
    singly reinforced, 99, 114  
    spandrel, 137  
    special shapes, 137

- Beams (*continued*)
  - stress distribution, 84, 94, 127
  - T-section, 127
- Bearing capacity, 310, 445, 456
- Bearing strength, 291, 456, 459
- Biaxial bending, 397
  - Bresler equation, 402
- Bond, 257
  - anchorage, 199, 201, 259
  - critical sections, 198, 268
  - development length, 261
- Bresler equation, 402
- Bridge design, 887
  - design philosophy, 891
  - load factors and combination, 892
  - vehicular loads, 896
  - design for flexure, 905
  - shear design, 906
  - loss of prestress, 913
  - deflection, 915
- Buckling, 343, 429
- Building code, 4
  
- C**
- CEB 90 model, 36
  - creep calculation, 37
  - shrinkage calculation, 36
- CEB 90–99 model, 39
  - creep calculation, 41
  - shrinkage calculation, 39
- Cement, 15
- Circular beam, 858
- Circular columns, 347
  - balanced, 381
  - compression controls, 370
  - tension controls, 367
  - Whitney equation, 96, 375
- Codes, 4
  - ACI, 4
  - others, 4
- Columns, 9, 342
  - axially loaded, 342
  - balanced condition, 359
  - biaxial bending, 397
  - braced, 344, 422, 429
  - capital, 610
  - circular, 347
  - composite, 344
  - compression failure, 358, 370
  - design charts, 387
  - eccentricity, 357, 363
  - effective length factor, 421
  - Euler buckling load, 429
  - interaction curves, 387, 398
  - lateral ties, 343
  - long, 349
  - minimum eccentricity, 358, 376, 392, 428
  - pedestal in footings, 456, 459
  - plastic centroid, 357, 363
  - radius of gyration, 349, 421
  - slenderness ratio, 343, 349, 421, 427
  - spacing of ties, 278, 345, 347
  - spiral columns, 347, 349
  - strength, 370
  - tied columns, 278, 343, 349
  - trial solution, 370
  - unbraced, 344, 422, 430
- Coefficient of expansion, 25
- Combined footings, 445
- Combined shear and torsion, 529
  - beams, 188
- Compressive stress, 17, 19
  - in cubes, 17
  - in cylinders, 17, 19
- Compressive stress distribution, 88
- Concrete, 15
  - admixtures, 16, 25
  - bond strength, 257
  - coefficient of expansion, 25
  - compressive strength, 17
  - constituents, 16
  - cover, 155
  - creep, 25
  - cube strength, 17
  - curing, 16
  - cylinder strength, 17
  - fibrous, 72
  - high-performance, 70
  - High strength, 70
  - lightweight, 70, 71
  - maximum strain, 18, 19, 84, 99
  - modular ratio, 24

- modulus of elasticity, 22
  - modulus of rupture, 21
  - plain, 21, 69
  - Poisson's ratio, 23
  - shear modulus, 24
  - shrinkage, 24
  - stress-strain diagram, 18
  - tensile strength, 19
  - water content, 24
  - Continuous beams, 555
  - Continuous one-way slabs, 329
  - Coulomb's theory, 493, 496
  - Cracks, 192
    - code equations, 245
    - control of, 245
    - main, secondary, shrinkage, 244
    - maximum width, 245
  - Creep, 25
    - coefficient, 29, 35, 37, 41, 43, 47
    - definition, 25
    - factors affecting, 26
    - magnitude, 26
    - strain, 26
  - Crushing strain, 19
  - Cube strength, 17
  - Curvature, 427, 432
    - double, 427
    - single, 427
  - Cylinder strength, 17
- D**
- Dead load factor, 91
  - Deep beams, 290
    - ACI design procedure, 293
    - AASHTO LRFD, 301
    - B*-and *D*-regions, 290
    - critical section, 329
    - Reinforcement, 299
    - Shear strength, 294
    - shear reinforcement, 309
    - strut-and-tie model, 290
  - Deflection, 226
    - compression steel, 233
    - cracked section for, 233
    - effective moment of inertia, 230
    - instantaneous, 237
    - limitations, 234
    - long-time, 233
  - Design loads, 6
  - Detailing, 329
  - Development length, 257
    - anchorage length, 259, 261, 273
    - bundled bars, 266
    - compression bars, 264
    - critical sections, 268
    - tension bars, 261
    - top bars, 259, 284
  - Diagonal tension, 188
  - Differential settlement, 443, 458
  - Direct design method, 616, 629
    - coefficients, 633
    - effect of pattern loading, 636
    - longitudinal distribution of moment, 630
    - transverse distribution of moment, 634
  - Distribution of soil pressure 448
  - Doubly reinforced concrete sections, 116, 162
  - Dowels in footings, 458
  - Drainage, 502
  - Drop panel, 610, 614, 621, 668
  - Ductility index, 588
- E**
- Earthquake, 786
  - Earth pressure, 92
    - active soil pressure, 493
    - passive soil pressure, 493
    - theories, 492
  - Effective depth, 91, 101, 116, 157
  - Effective flange width, 127
    - L-sections, 137
    - T-sections, 128
  - Effective surcharge, 497
  - Effective length of columns, 422
  - Effective moment of inertia, 230
  - End anchorage, 295, 734, 777
  - Equilibrium conditions, 91, 362
  - Equivalent frame method, 681
  - Equivalent stress block, 94, 129
  - Euler buckling load, 429
  - Expansion, 24



**F**

- Factored loads, 91
- Failure, 86, 88
  - balanced section, 88, 99
  - bending, 99
  - diagonal tension, 320
  - punching shear, 452
  - torsion, 523
- Fib-mc 2010 model 43
  - creep calculating 43
  - shrinkage calculating 43
- Flat plate, 326, 427, 611, 621
- Flat slab, 610, 625
- Flexural bond, 254
- Flexural Failure, 88
- Floor system, 324, 335, 614
  - concrete joist, 336
  - flat plate, 611, 614
  - flat slab, 610, 614, 621
  - one-way joist, 324, 335
  - one-way slab, 227, 324, 339
  - ribbed slab, 324, 336
  - slab-beam, 558, 681
  - two-way slab, 610
- Footings, 443
  - allowable soil pressure, 450
  - bearing stress, 456
  - one-way shear, 451
  - on piles, 483
  - punching shear, 452
  - soil pressure, 448
- Footings, types, 446
  - combined, 472
  - exterior column, 474
  - interior column, 475
  - isolated, 445
  - pile, 483
  - plain, 459
  - rectangular, 445
  - trapezoidal, 445
  - wall, 443, 445, 460
- Frames, 555, 561
  - braced, 422, 428
  - unbraced, 423, 429
- Friction coefficient, 741
- Friction losses in prestressing force, 740

**G**

- GL 2000 model, 33
  - creep calculation, 34
  - shrinkage calculation, 34
- Gravity retaining wall, 490
- Gross moment of inertia, 230

**H**

- High-performance concrete, 70
- Hooks, 272
- Hoop, 344, 533

**I**

- Impact, 6
- Inertia, moment of, 230
- Inflection points, 268
- Initial modulus, 22
- Interaction diagram, 358, 376, 387
- Interaction surface, 399

**J**

- Joints, 26, 179, 290, 562, 820

**L**

- Lateral ties, 257, 578
- Limit analysis, 582
- Load factors, 8, 91
  - dead load, 8, 91
  - live load, 8, 91
  - wind load, 6, 92
- Longitudinal reinforcement(torsion), 534
- LRFD, 9
- L-shaped sections, 137, 343

**M**

- Magnification factor, 428
- Middle strip, 619
- Modes of failure, 18, 65
- Modular ratio, 24, 228
- Modulus of elasticity, 22
  - in direct compression, 22
  - normal-weight concrete, 23
  - steel, 75
- Modulus of rupture, 21

- Moment of inertia, 230
  - Compression member, 426
  - effective, 230
  - gross, 228
  - polar, 528, 661
- Moment magnification factor, 429, 430
- Moment redistribution, 539, 596
  
- N**
- Neutral axis, 84, 87, 105
- Nominal moment capacity, 100, 161, 400, 757
- Nominal strength, 8
  - column strength, 391
  - flexural strength, 90, 94
  - shear strength, 543, 626, 629
  
- O**
- One-way slabs, 227, 324
- Overreinforced, 99, 579, 732
- Overturning moment, 810
  
- P**
- Passive soil pressure, 493
- Pattern loading, 636
- Pile caps, 446
- Plastic centroid, 356
- Plastic design, 556, 579
- Plastic hinges, 560, 579
- Polar moment of inertia, 528, 662, 867
- Posttensioning, 724
- Prestress, 724, 736
  - design approach, 756
  - losses, 737
  - partial, 760
  - strands, 737
- Pretensioning, 726
  
- R**
- Radius of gyration, 349, 421
- Rectangular sections, 110, 114, 116, 123, 152, 162
  - balanced, 99
  - compression control, 88
  - tension control case, 88
- Redistribution of moments, 539, 556, 596
- Reinforcing steel, 72
  - anchorage, 201
  - areas, 72, 75
  - balanced section, 88
  - bar sizes, 72
  - deformed bars, 72
  - development length, 257
  - flexural bond, 258
  - grades, 72, 74
  - hooks, 272
  - maximum percentage, 101
  - modulus of elasticity, 228
  - sizes, 72
  - spacing, 114, 128, 155
  - spiral, 278, 344
  - splices, 263, 276
  - stirrups, 76, 195, 198, 200
  - strands, 74, 736
  - tie spacings, 279, 350
  - wire fabric, 74
  - yield strength, 74
- Retaining walls, 490
  - cantilever, 490
  - gravity, 490
- Rotation capacity, 196, 579
  
- S**
- Safety provisions, 8
  - capacity reduction factors, 8, 91
  - load factors, 91
- Secant modulus, 22
- Seismic design, 786
  - acceleration, 786
  - base shear, 804
  - boundary elements, 841
  - category, 786
  - coupling beam, 841, 847
  - design category, 786
  - design response spectrum, 787
  - flexural design, 820
  - fundamental period, 789
  - intermediate moment frame, 805, 820, 855
- International Building Code (IBC), 786
- longitudinal reinforcement, 821
- redundancy coefficient, 819

- Seismic design (*continued*)
    - seismic response coefficient, 799
    - shear walls, 805, 811, 815, 842
    - simplified analysis, 812, 815
    - special moment frames, 805, 813
    - strong column-weak girder, 820, 832
  - Semicircular beam, 865
  - Shear, 188
    - failure, 88, 191
    - footings, 449
    - punching, 449, 452
    - stirrups, 192, 195, 198
    - stress, 188
    - thickness, footings, 455, 459, 483
    - wall footing, 443, 445, 461
  - Shear head, 626
  - Shear modulus, 24
  - Shear reinforcement, 188
    - in beams, 188
    - design procedure, 198
    - inclined stirrups, 195
    - minimum reinforcement area, 198
    - torsion, 191, 201
  - Shear strength of beams, 193
    - critical section, 198
    - diagonal tension, 188, 191
    - stress distribution, 188
  - Shrinkage, 24
    - in concrete, 24
    - and creep, 25
  - Sideway, 825
  - Slabs, 324, 610
    - bending moments, 326
    - concrete cover, 337
    - continuous, 328, 333
    - design, 328, 426, 610, 614
    - flat, 621
    - hollow, 335
    - minimum steel ratio, 329
    - minimum thickness, 227, 328, 620
    - one-way, 324
    - reinforcement, 328
    - ribbed slab, 324, 328, 611
    - solid, 326
    - two-way, 610
    - waffle, 611, 614, 634, 672
  - Slenderness ratio, 343, 420
  - Spirals, 93, 195, 278, 345
  - Splices, 263, 276
  - Split cylinder, 18, 20
  - Square footings, 454
    - depth, 451, 452
    - design consideration, 449
    - moments, 455
    - reinforcement, 455
  - Stirrups, 192, 198
    - ACI Code, minimum, 198
    - closed, 201, 274
    - design, vertical, 201
    - maximum spacing, 200, 262
    - minimum area, 198
    - vertical, 201
  - Stress–strain curve, 18, 23
    - concrete, 19, 23
    - steel, 72
  - Strut-and-tie method, 290
    - design procedure, 305
    - design requirements, 295
- T**
- Tables:
- Appendix A, 994
  - Appendix B, 1004
  - Appendix C, 1012
- T-beams, 127
    - analysis, 127
    - effective width, 127
    - strength, 129
  - Temperature and shrinkage reinforcement, 328
  - Tension-controlled, 90
  - Ties (columns), 345
  - Time-dependent deflection, 233
  - Time-dependent losses, 740
  - Top bar (development length), 262
  - Torsion, 523
    - analysis, elastic, 529
    - analysis, ultimate, 529
    - in circular sections, 528
    - combined shear and torsion, 529

- equations, 534
- longitudinal reinforcement, 534
- reinforcement, 534, 540
- spandrel beam, 539
- stirrup design, 541
- Strength, 534
- strength reduction factor, 93
- stresses, 525
- Transverse reinforcement, 823
- T-section, 109, 127
- Two-way action (shear), 452, 629
- Two-way slabs, 610

## U

- Unbraced frames, 344
- Units, 5
  - metric, 5, 1004
  - U.S. customary, 5, 994
- Unit weight, 69, 1001

## V

- Virtual work method, 582
- V-shape beam, 878

## W

- Waffle slab, 611, 614, 634, 672
- Wall footings, 445, 459
- Walls, 490
  - basement walls, 491, 513
  - retaining walls, 490
- Water–cement ratio, 15
- Welded wire fabric, 74, 76
- Wind load factor, 6

## Y

- Yield line method, 618
- Yield point, 77
- Yield strength, 72, 74, 75

# **WILEY END USER LICENSE AGREEMENT**

Go to [www.wiley.com/go/eula](http://www.wiley.com/go/eula) to access Wiley's ebook EULA.