

---

**E-TRAINING PRACTICES  
FOR PROFESSIONAL ORGANIZATIONS**

## **IFIP – The International Federation for Information Processing**

IFIP was founded in 1960 under the auspices of UNESCO, following the First World Computer Congress held in Paris the previous year. An umbrella organization for societies working in information processing, IFIP's aim is two-fold: to support information processing within its member countries and to encourage technology transfer to developing nations. As its mission statement clearly states,

*IFIP's mission is to be the leading, truly international, apolitical organization which encourages and assists in the development, exploitation and application of information technology for the benefit of all people.*

IFIP is a non-profitmaking organization, run almost solely by 2500 volunteers. It operates through a number of technical committees, which organize events and publications. IFIP's events range from an international congress to local seminars, but the most important are:

- The IFIP World Computer Congress, held every second year;
- Open conferences;
- Working conferences.

The flagship event is the IFIP World Computer Congress, at which both invited and contributed papers are presented. Contributed papers are rigorously refereed and the rejection rate is high.

As with the Congress, participation in the open conferences is open to all and papers may be invited or submitted. Again, submitted papers are stringently refereed.

The working conferences are structured differently. They are usually run by a working group and attendance is small and by invitation only. Their purpose is to create an atmosphere conducive to innovation and development. Refereeing is less rigorous and papers are subjected to extensive group discussion.

Publications arising from IFIP events vary. The papers presented at the IFIP World Computer Congress and at open conferences are published as conference proceedings, while the results of the working conferences are often published as collections of selected and edited papers.

Any national society whose primary activity is in information may apply to become a full member of IFIP, although full membership is restricted to one society per country. Full members are entitled to vote at the annual General Assembly, National societies preferring a less committed involvement may apply for associate or corresponding membership. Associate members enjoy the same benefits as full members, but without voting rights. Corresponding members are not represented in IFIP bodies. Affiliated membership is open to non-national societies, and individual and honorary membership schemes are also offered.

---

# **E-TRAINING PRACTICES FOR PROFESSIONAL ORGANIZATIONS**

***IFIP TC3 / WG3.3 Fifth Working Conference on eTRAIN Practices  
for Professional Organizations (eTrain 2003)  
July 7-11, 2003, Pori, Finland***

*Edited by*

**Paul Nicholson**  
*Deakin University  
Australia*

**Mikko Ruuhonen**  
*University of Tampere  
Finland*

**J. Barrie Thompson**  
*University of Sunderland  
United Kingdom*

**Jari Multisilta**  
*Tampere University of  
Technology  
Finland*

**KLUWER ACADEMIC PUBLISHERS**  
NEW YORK, BOSTON, DORDRECHT, LONDON, MOSCOW

eBook ISBN: 0-387-23572-8  
Print ISBN: 1-4020-7756-4

©2005 Springer Science + Business Media, Inc.

Print ©2005 by International Federation for Information Processing.  
Boston

All rights reserved

No part of this eBook may be reproduced or transmitted in any form or by any means, electronic, mechanical, recording, or otherwise, without written consent from the Publisher

Created in the United States of America

Visit Springer's eBookstore at:  
and the Springer Global Website Online at:

<http://ebooks.springerlink.com>  
<http://www.springeronline.com>

# Contents

Preface	xi
<b>Section 1: Theories and Paradigms</b>	<b>1</b>
Identifying Hypermedia Browsing Strategies KRISTIAN KIILI AND HARRI KETAMO	3
Simulations as Mental Tools for Network-Based Group Learning MIIKA LEHTONEN	11
E-training or E-learning? PAUL NICHOLSON	19
Pedagogical Models in Network-Based Education SANNA VAHTIVUORI-HÄNNINEN	29
The Effects of IT-Based Training on Employees Uptake of New Technologies in the Work-Place LENA MAE WILKINSON AND MARGARET COX	37

Focus Group Report: Mobility and Education <b>CHAIR:</b> RAYMOND MOREL, <b>RAPPORTEUR:</b> ARTHUR TATNALL <b>PARTICIPANTS:</b> HARRI KETAMO, TIMO LAINEMA, JARI KOIVISTO AND BARBARA TATNALL	45
<b>Section 2: Programs and Curricula</b>	<b>49</b>
‘Anybody Out There a Real Expert?’ MEERI HELLSTÉN	51
What Students Expect from E-Moderation UDO HINZE AND GEROLD BLAKOWSKI	61
A Model for Planning, Implementing and Evaluating Client- Centered IT Education ILKKA KAMAJA AND JUHA LINDFORS	69
Breaking New Ground in Professional IT-Training WALTER MATTAUCH AND MATTHIAS ROHS	77
Taking the E-Train in University Education ANNE MCDOUGALL, TED CLARK AND LYN CAMPBELL	85
<b>Section 3: Industry Practices</b>	<b>93</b>
Competence Development Supported by Digital Means in a Knowledge-Intensive Company ARI ALAMÄKI AND KALLE MÄKINEN	95
Electronic Mail Competitions VALENTINA DAGIENE AND GINTAUTAS GRIGAS	103
Integrating Needs Assessment Within Next Generation E-learning Systems DIEUWKE DE HAAN, PATRICK WATERSON, SONJA TRAPP AND DIETMAR PFAHL	113
Cognition, Culture and Effective E-Praxis Guiding Principles MOHAN R. GURUBATHAM	121
The Teacher: from a Responsible Student’s Point-of-View MARIJKE HEZEMANS AND MAGDA RITZEN	129

The Virtual Office JOHN HOLMSTRÖM AND VELI-JUKKA LEPPÄNEN	137
Introducing Organizational Characteristics in Learning Environments TIMO LAINEMA	145
Digital Competence Development as Strategic Learning KALLE MÄKINEN AND ARI ALAMÄKI	155
The Impact of the Implementation of Distance Education Systems in a Telecommunications Company MARINA K. NAKAYAMA, RAQUEL PROANO, BIANCA PILLA AND RICARDO A. SILVEIRA	163
The Performance of Virtual Teams MARINA K. NAKAYAMA, MICHELLE D'ÁVILA MATOSO AND RICARDO A. SILVEIRA	171
<b>Section 4: Collaboration</b>	<b>179</b>
Managing Distributed University Courses KIRSTI ALA-MUTKA AND SANNA-MARIA RÄISÄNEN	181
Enabling Postgraduate Learning in the Workplace NICOLA BEASLEY, JOHN FORD AND NILS TOMES	189
A Better E-Train BILL DAVEY AND ARTHUR TATNALL	197
Social Learning within Electronic Environments CAROLYN DOWLING	205
Mobile Technologies and Education HEIKKI HAAPARANTA AND HARRI KETAMO	213
Towards Multilateral Co-operation of University, ICT-Businesses and Public Organizations in the Rovaniemi Region MIKA SALOHEIMO, MIINA KONTTINEN, ILKKA KAMAJA AND JUHA LINDFORS	221
<b>Section 5: Learning Environments</b>	<b>229</b>

Experimenting with Digital Television Learning Environments PÄIVIA ARRENIEMI-JOKIPELTO, JUHA TUOMINEN, SEPPÖ KALLI AND TOMMI RIIKONEN	231
Printed Media, Hypertext and Chatterbots in Learning MARIA JOSÉ CARVALHO DE SOUZA DOMINGUES AND RAUL SIDNEI WAZLAWICK	239
Developing International Leadership in Educational Technology NIKI DAVIS, ANDREW BROWN AND RICK FERDIG	247
Distance Learning Approaches in Teacher Training YAACOV J KATZ	255
Building Technology-Based Training on Relevant Learning Perspectives TIMO LAINEMA	263
Interactive 3D Virtual Hydraulics L. PAUNIAHO, M. HYVÖNEN, R. ERKKILÄ, J. VILENIUS, K. T. KOSKINEN AND M. VILENIUS	273
Accessibility and Mobile Learning ANTTI SYVÄNEN, MIKKO AHONEN, ANU JÄPPINEN, MARIKA PEHKONEN, HANNE TURUNEN AND TEIJA VAINIO	281
<b>Section 6: Design</b>	<b>289</b>
Developing Time-Sensitive Hypertext Linking and Navigation Support ANNELI HEIMBÜRGER	291
Virtual Learning Modules for Trainees HEIKE KÖPPE	299
A New Spider on the Web ARTHUR TATNALL AND BILL DAVEY	307
Logistics for Learning Objects BERND TSCHIEDEL, ALEKSANDER BINEMANN-ZDANOWICZ AND BERNHARD THALHEIM	315



Implementing the Learner-Centred Design Paradigm for Web-Based Training Curricula PANAGIOTIS ZAHARIAS AND ANGELIKI POULYMENAKOU	325
Implementation and Use of a Web-Based Learning Environment JUHA LINDFORS	333
Index	341

# Preface

Mikko Ruohonen  
University of Tampere  
Finland

Jari Multisilta  
Tampere University of Technology  
Finland

IFIP Working groups 3.3 (Research on Education Applications of Information Technologies) and 3.4. (IT-Professional and Vocational Education in Information Technology) organized an open conference on 'E-training Practices for Professional Organizations' between July 7-11, 2003 in the famous jazz city of Pori, Finland. The general topic and themes of the conference were decided about three years before the conference. At that time, the year 2000, we were still living in 'the hype time of ICT use' in many countries. However, the first signs of change were already there; the burst of the 'hype bubble' was awaiting us.

We were interested in examining the opportunities, experiences and working ideas in the domain of electronic learning and training, especially for professional organizations. We had witnessed many e-learning and multimedia systems in organizations, but they have been somewhat isolated from the organisational context. It seemed that we needed to address not only the potential of technology, but also the limitations (or opportunities) of organisational strategies and processes. We can now say that we were right,

although many of the e-learning technology companies are now in financial trouble, the tendency seems towards an integration of e-business, e-work and e-learning processes. How to successfully combine learning, working, and managing is the key issue for the future. The master of these processes needs to be aware of technology opportunities, guidelines of emerging organizations and the transformation potential of people. This demands new qualities for development.

Our conference keynotes reflect the multifaceted nature of e-training efforts. Riitta Vänskä from Nokia Corporation, Finland, responsible for creating the basics of Nokia's e-learning for internal competence development, raised a new important concept she called 'n-learning'. Although this sounds like a new 'buzz letter' for this business, it involves an important rationale. N-learning i.e., network learning, is the emerging issue in organisational learning. When talking about communities of practice, network economy and inter-organisational learning, we need to face the challenges of learning systems supporting the aforementioned. Learning in a network is both formal and informal. Informal learning needs to be context-aware learning—you might not have the time or place to find your formal learning system. Nokia has explored many mobile or wireless work and learning systems. They are interested in seeing whether work and learning processes can be fostered with mobile technologies.

Director and Professor Jarmo Viteli from the eTampere Development Program raised many examples of the development of a knowledge society, of which Finland has been famous worldwide. Based on the eEurope initiative, the city of Tampere has invested in developing the Tampere area as the spearhead city of Finland's knowledge society developments. He commented that Tampere area companies had produced many innovations, such as the first analogue and digital mobile phone calls (1974, 1991), the bioresorbable implant, and a walking forest harvester (1984, 1995). Lately more 'smiling' innovations have appeared, such as world's first Internet-bus and—of course when in Finland—an Internet-connected sauna. This has provided the basis for serious investment in the research and development of e-learning issues.

This is also related to our discussion on contexts; at the level of knowledge society development, it is difficult to test or exercise any innovations if you do not have a large commitment to do society-wide or at least regional, development. The Larger Tampere area aims at to be a living laboratory of this development and to raise important issues in that field.

Carolyn Dowling, professor and Head of the School of Business and Informatics at Australian Catholic University, continued this discussion by arguing that it is also important to situate learning within the type of co-operative and collaborative problem-solving environment characteristic of

most contemporary workplaces. Context is everything but it is very challenging to manage. We need to be sensitive when designing interactivity and social learning into our systems.

Some people might not like the intrusive and ubiquitous nature of learning systems. Technologies change fast, but people often do not. Carolyn Dowling pinpointed that we can exploit pedagogical agents for improving learning. At the end, handheld communications devices and agent technologies may enhance our ability to deliver education and training with maximum flexibility, and in an interactive social context.

The cultural-cognitive impact of e-training development was delivered by Professor Mohan Gurubatham from the International Business School of the University of Technology, Kuala Lumpur. His talk delved into the origins of knowledge creation in a cultural context. Cultural issues, whether national or organisational ones, affect the process of learning and systems implementation. Professor Gurubatham wanted to shift from technology-oriented studies to more 'mind-bias' or consciousness studies. Technology provides a learning platform, but the real potential is in developing people's conceptual richness and higher-level cognitive skills. Involvement and interactivity together provides new avenues for development such as mobile environments or digital TV applications. At the end, these applications and systems need to be fitted into the cultural context. The basic message was that you cannot change culture, but you can learn it, accept it, and exploit it.

Etrain 2003 was also a forum for the 40th birthday celebration of IFIP's Technical Committee 3. We were happy to host this event and proudly provide avenues for the next 40 years work. The papers, workshops and demonstrations presented in the conference reflected many of the challenging areas we need to address. Papers stressing the need to address theoretical and paradigmatic awareness in addition to technology are very important to align business, working and learning processes. In those papers constructivist, social learning, and situated learning were highlighted and also empirically shown. This implies the need to have more context-driven e-training development. Learning results might be superficial if the training processes do not address expertise development, just cognitive level evaluation.

Many company examples verified our assumptions and were pinpointing, for example, interactive, network-based and competence-driven approaches. Industry people are also active in driving their own professional profiles for developing competence definitions. Our conference also offered a forum to exchange ideas in that sector. Many of the design issues are important both in technology side and curriculum side. It seems that technology is always one step ahead and the problem is how to boost sound implementation of

those technologies. Technology changes fast but people not. Inter-organisational arrangements and collaboration with industries were topics under new forms of training and learning. Networked economy provides a platform for that if you can agree on rules and commitments between key actors of that collaboration.

In summary, in the future we will need a balanced view of “e-thinking”. It means integration of e-business, e-work and e-learning domains. Without strategy and organizational objectives you might miss your focus of e-training. Organizations are not able to fund projects without focus. Work processes are the context into e-work practices need to be fitted. We need to be aware that radical views on sociology of work and “over-liberation” of workers might lead us to confrontations that lose the target of organizational development. Also e-learning might get lost by over-emphasizing traditional “class-room pedagogy” and only cognitive level results. Organisational learning in many domains needs to be addressed, and there is much work to be done to integrate processes for individual, group, organizational and even inter-organisational learning.

We are very grateful to our supporters; the European Union IST programme, The City of Pori, the Foundation for Economic Education, several companies (Lännen Puhelin Oy, Satakunnan Puhelin Oy, Elinar Oy Ltd, Itecon Oy) and organizations such as Pori Jazz Association. We are grateful to all voluntary members of the International Program Committee of Etrain 2003, the personnel of Tampere University of Technology in the Pori Unit and all of our IFIP/TC3 related colleagues who made this conference a success. We will remember Pori and the E-train will continue its ride to the next stop!

We are happy to provide this volume of contributions to our readers and hope that this collection of research and development efforts will show the way for further events in IFIP TC3 activities!



# **SECTION 1: THEORIES AND PARADIGMS**

# IDENTIFYING HYPERMEDIA BROWSING STRATEGIES

## *A Statistical Approach*

Kristian Kiili and Harri Ketamo

*Tampere University of Technology, Pori*

**Abstract:** Browsing strategies have been studied mostly from the browsing patterns point of view. In this paper the browsing strategies have been approached with statistical methods. As a final result, a three-cluster browsing strategy model was defined according to empirical data, collected from web-based course. This model could be used as a background for constructing adaptive navigation for web-based learning material. Also a revised framework for navigation is presented.

**Key words:** hypermedia, modelling, learning materials

## 1. INTRODUCTION

Educational hypermedia can be defined as a learning environment that relies on user-controlled choices to access information in the form of various media (Reed & Oughton, 1997). Hypermedia allows users to make decisions about what information to access and in what sequence. The user constructs the structure of a personal hyperspace, the previous knowledge about the domain controls, and redirects users' behaviour in hyperspace. According to Lawless et al. (2003) this changes the nature of learning that occurs with hypermedia systems compared to traditional learning environments by adding users responsibility to construct the structure of the hyperspace. In addition users have to be able to identify what information will further enhance their understanding and how to access this information. Thus, users' ability to structure and manage their own navigation is becoming a required skill in hypermedia based learning environments (Ford & Chen, 2000). In current research terms navigation and browsing are not well defined. These



terms are sometimes used wrongly as synonyms but also determined as sub-classes for each other.

In the literature review the terms are used as they are mentioned in the original publications. Spence (1999) has presented a semantic framework for navigation. He defines navigation as the creation and interpretation of an internal model. According to him navigation consists of browsing, modelling, interpretation and the formulation of browsing strategy. Such as Spence, we consider browsing as a part of navigation process. In discussion section we present our vision about navigation framework inspired by Spence.

## **2. BROWSING STRATEGIES**

Despite the fact that two users do not navigate a hypermedia space in exactly the same way, similar navigational patterns do emerge among users. At least three common navigational profiles have been identified: 1) knowledge seekers, 2) feature explorers, and 3) apathetic hypertext users. Knowledge seekers pursue screens that contain material needed to enhance comprehension of the certain content. Additionally, knowledge seekers tend to select screens in logical sequences and acquire information in a systematic manner. Feature explorers spend a disproportionate amount of time interacting with special features such as movie clips, sound and visual effects, and graphics. It seems that apathetic hypertext users do not care either to gather information or to explore its features. Their navigational paths do not reveal logical orders and the interaction with the system is characterized with short time intervals. (Lawless, 1998.)

According to McAleese (1989) browsing is using explicit or implicit associations to determine the next item to be accessed. People using hypermedia for similar purposes produce similar, but not identical browsing patterns. Browsing pattern can be defined as a series of movements through the hypermedia. Canter et al. (1985) describes four lower level browsing constructs presented in Figure 1, which combinations form more complex patterns. These higher-level browsing patterns occur as the user employs a browsing strategy. Thus, browsing strategy can be defined as a method employed by the user in order to fulfil their task while using a hypermedia system.

The use of browsing constructs in recognition of browsing strategies is challenging because it is not readily apparent where one construct ends and another construct begins. It is also possible that constructs merge into each other. The time spent in each node is also an important factor when identifying browsing patterns. It may be that user is using the node as a

stepping stone to another node or to be interested in the content of the node itself. Thus there may occur several types of browsing patterns including the same nodes. (Mullier, 1999.)

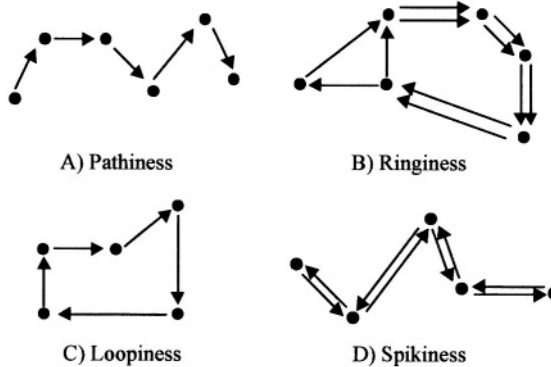

Figure 1. Browsing constructs

The study of Mullier et al. (2002) give some evidence that low-level browsing patterns are used to different degrees by different types of users. Expert users tended to use loops and rings with a high degree of path branching. They did not use spikes as much as more novice users. Mullier et al. (2002) also states that there is a finite number of browsing strategies and learning styles and therefore users with similar backgrounds may tend to behave in similar ways when using a hypermedia domain.

Canter et al. (1985) have described five browsing strategies:

1. Scanning strategy, the aim of which is to cover a large area without depth. It consists of a mixture of deep spikes and short loops.
2. Browsing strategy, in which a user just follows the links until his or her interest is caught. It consists of many loops and few large rings.
3. Searching strategy, in which a user seeks the marks of the requested issue. It consists of ever-increasing spikes with few loops.
4. Exploring strategy can be seen as finding out the extent of the information given. It consists of many different paths.
5. Wandering is purposeless and unstructured shilly-shallying that represents the lack of strategy. It consists of many medium sized rings as the user ambles along and inevitably revisits nodes.

Browsing strategies tends to be very complex because users can apply more than one strategy during a particular session and may use different strategies at different times. According to Catledge and Pitkov (1995), users tended to use different strategies, and hence produced different browsing patterns, if they had well defined goals than if they had unclear goals.

Additionally, users' goals can change at any point they browse because they can find some interesting information that differs from previous goals.

### **3. RESEARCH QUESTION AND METHOD**

The main goal of this study is to create methods for finding out the theoretical browsing strategies from observed user behaviour. These methods could be used as a background for future studies in adaptive navigation systems. Adaptive navigation should be designed so that 1) it is invisible for the user and 2) it could react fast to changes in users' behaviour. Therefore the system should understand the user behaviour without other human input than the user behaviour in web.

Browsing strategy is usually defined according to browsing patterns. It is also possible that the same browsing strategies can be found out from users' statistical behaviour in hyperspace. If browsing strategies can be defined from statistical user behaviour, we could implement a lightweight system that could both observe and analyse the browsing strategies. The benefits of this kind of statistical based user-modelling engine can be found especially when the computational speed of the server is limited and heavy pattern recognition could not be used. This could occur for example when there are large numbers of users in the server at the same time.

The empirical study was done in spring 2002 in co-operation with TietoEnator e-Learning Solutions. Approximately 400 students started the course, but finally 226 students finished the course. In this study we focus only on those users who finished the course. The total number of nodes in the learning material was 52. From a user point of view it was not necessary to read all the nodes, even though it was possible. The length of the users' navigation paths varied from 30 up to 300 visited nodes. The students participated in the course from their own PC-work stations. There were no lectures or other group meetings during the course. The students were aware that their behaviour could be recorded, but their identity could not be traced afterwards from these records.

The course was TietoEnator's internal web-course about business strategies. It consisted of four different views of the issue that were meant to describe different views designed for personnel in different positions. Materials were produced with Macromedia Flash and XML-features were used to communicate with the external logging system. Because of analysing consisted of constructing relation networks between log events, the user behaviour log was created directly in MySQL-database.

For the statistical analysis the log files were summarized and the following variables were calculated separately for each user from raw log-data:

1. Number of visited nodes
2. Number of visited nodes in path A - D
3. Average visiting time / node
4. Average visiting time / node in path A – D
5. Standard deviation for visiting time / node
6. Standard deviation for visiting time / node in path A – D

The main variables were 1) the number of visited nodes and 2) the average visiting time per node. The detailed variables were calculated to ensure the validity of statistical analysis.

The biggest threat to validity was the possible effect of the context to users browsing strategy. To make sure that the browsing strategy was not depending on the context, the browsing strategies in different contexts (A-D) were compared. There were strong correlations ( $0,901 < r < 0,216$ ;  $0,000 < p < 0,003$ ) between the main variables and the detailed variables. This proves that the general variables describe users' behaviour in all of the contexts. In other words, the context did not affect the browsing strategies.

## **4. RESULTS**

In this paper we focus on the main result of the study: the clusters found from the users' behaviour. These analyses were done with K-means clustering. From the literature review we can see that there were three to five browsing strategies, depending on the definitions. In our analysis we defined these strategies from our statistical data by clustering the users and then explaining the meaning of the clusters.

First we approached Canter's five- strategy model. Five clusters could be found from the user data (Figure 2). From these, the cluster that has a lot of visited nodes with short visiting times represents the wandering-strategy in Canter's model. Other strategies cannot be described in the terms of Canter, but we could build software that tries to give an explicit category for single user according to this five-cluster strategy definition. Unfortunately, this browsing profiler software could not calculate explicit browsing strategy for the user. Most users got several uncertain strategies as a result of this modelling. This indicates that this five-cluster model is not relevant enough for the basis of the statistical browsing strategy modelling.

Secondly we approached traditional three-strategy model. Three clusters were found from the user data (Figure 3). Strategy called 'apathetic hypertext users' can be seen as the same cluster as 'wandering-strategy', where user had

visited a lot of nodes with short visiting times. ‘Knowledge seekers’ - category can be seen as a combination of ‘searching- strategy and exploring- strategy’. In this cluster the users search information and therefore they have a small number of visited nodes with short average visiting times. Naturally, when they find the information they searched, they have longer visiting time in the specific node. ‘Feature explorers’ do not have explicit corresponding categories in Canter’s model. Feature explorers differ from knowledge seekers by the average node visiting time. In this study, feature explorers are not defined according to use of special features (video clips etc.) they just had significantly longer average visiting times. We rather concern these users as readers that cannot decide what information to access. Therefore they read everything in a linear way.

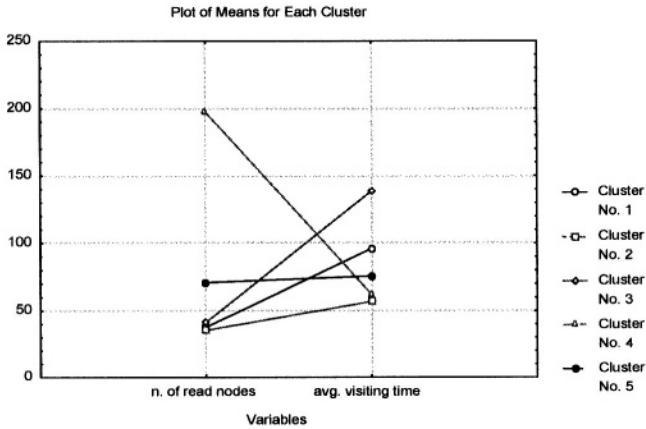

Figure 2. Five-cluster model.

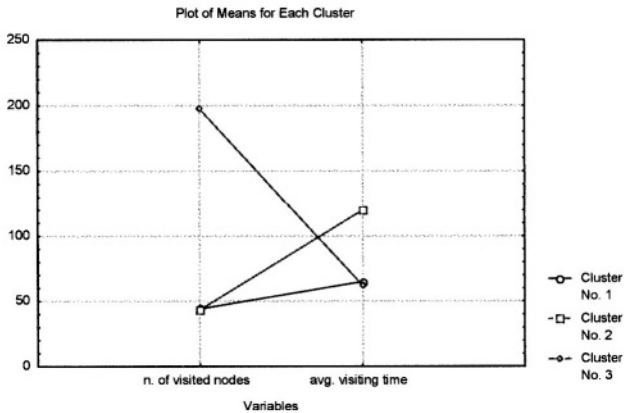

Figure 3. Three-cluster model

This three-cluster browsing model could be used as a background for browsing profiler software. The browsing profiler could calculate the explicit browsing profile for over 60% of users. The clustering rules will be developed so that even more users could be profiled with browsing profiler software.

## 5. CONCLUSIONS

The statistical browsing strategy modelling was promising. The browsing strategies, that many researchers have defined according to browsing patterns, could be also defined by statistical methods. The strategies and definitions are not exactly the same as pattern based strategies, but they certainly describe some common features of users browsing in the learning material.

In Figure 4, a revised framework for navigation is presented. It is divided to three main components on the basis of information processing theory. The lowest level is called *action*: that describes the simple stimulus-reaction-response chain. In the second level, the user has made a selection about information that is processed in working memory. In this level the user employs a browsing strategy that is formulated on the basis of prior knowledge. Wandering represents the lack of strategy and it can be considered as transition of action and browsing. In summary browsing is regarded as a registration of content.

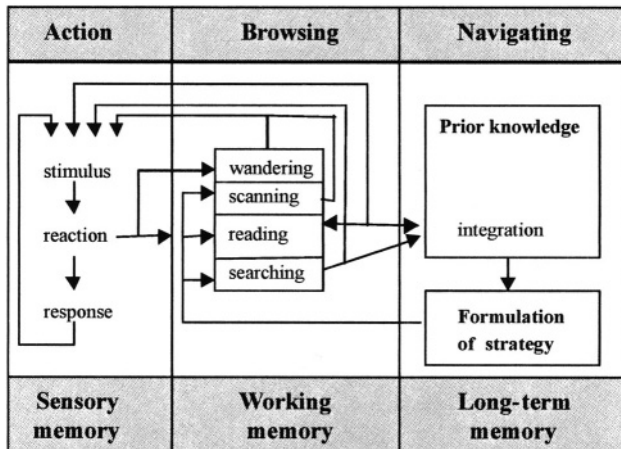

Figure 4. Framework for navigation

When the employed browsing strategy leads to integration between browsed information and prior knowledge, the user has achieved the last level, navigation. In other words navigation is concerned with learning about a space. The framework will be fully explained and discussed in forthcoming publications. In the future, the statistically defined strategies will be compared to pattern based strategies in more detail. To increase validity we will also use some qualitative methods to gather data from users' behaviour in hyperspace. The goal for this is to develop more exact and more easily traceable definitions for browsing strategies. The browsing profiler software will also be developed and used in the future studies. The main goal is to apply these methods and tools into an adaptive web-based course management system.

## REFERENCES

- Canter, D., Rivers, R. & Storrs, G. (1985). Characterising user navigation through complex data structures. *Behaviour and Information Technology*, 4(2), 93-102.
- Catledge, L. & Pitkov, J. (1995). Characterizing browsing strategies in the World-Wide-Web. In *Computer Networks and ISDN systems* (Vol 27), (pp.1065-1073), Darmstadt, Germany: Elsevier Science.
- Lawless, K.A. & Kulikowich, J.M. (1998). Domain knowledge, interest, and hypertext navigation: A study of individual differences. *Journal of Educational Multimedia and Hypermedia*, 7(1), 51-70.
- Lawless, K.A., Mills, R. & Brown, S.W. (2003). Children's Hypertext Navigation Strategies. *Journal of Research and Technology in Education*, 34(3), 274-284.
- McAleese, R. (1989). Navigation and Browsing in Hypertext. In R. McAleese (Ed.), *Hypertext theory into practice*. (pp.6-44). Oxford, UK: Intellect Limited.
- Mullier, D., Hobbs, D. & Moore, D. (2002). Identifying and Using Hypermedia Browsing Patterns. *Journal of Educational Multimedia and Hypermedia*, 11(1), 31-50.
- Mullier, D. (1999) *The application of neural network and fuzzy-logic techniques to educational hypermedia*. Unpublished doctoral dissertation, Leeds Metropolitan University, United Kingdom. [online: [www.lmu.ac.uk/ies/comp/staff/dmullier/](http://www.lmu.ac.uk/ies/comp/staff/dmullier/)].
- Reed, W.M. & Oughton, J.M. (1997). Computer experience and interval based hypermedia navigation. *Journal of Research of Computing in Education*, 30(1), 38-52.
- Spence, R. (1999). A framework for navigation. *International Journal of Human-Computer Studies*. 51, 919-945.

## BIOGRAPHY

Kristian Kiili has research interests in the users' behaviour in digital learning materials. Recent research has focused on identifying browsing strategies and developing a theoretical model for navigation process. Harri Ketamo has research interests in educational technologies and user modelling. Recent research has focused on adaptive studying environments and developing network-based observation methods and tools.

# **SIMULATIONS AS MENTAL TOOLS FOR NETWORK-BASED GROUP LEARNING**

Miika Lehtonen

*University of Lapland*

**Abstract:** The article presents pedagogical and technological applications developed and studied as part of the research project 'Web-supported Mental Tools in Technology Education' at the University of Lapland. The applications allow simulation tools, modern network-based solutions that support learning, and other mental tools, as well as traditional and modern digital learning materials, to be smoothly integrated into normal teaching-studying-learning activity. For example, efforts have been made make use of edutainment as part of the nature of tools and materials and game-like interactivity to enhance the learning process. The broader framework for the model of learning activity that is being developed and studied in the project centers on the question how and through which learning activity (learning process) study and learning in the field of electric technology and electronics (technical work and technology education) can be organized to take into account the challenges posed by the post-industrial information society.

**Key words:** Distance Learning, Games, Learning Models, Research, Simulation

## **1. INTRODUCTION**

In a somewhat light-hearted vein, one could say that high-level work on the part of a teacher — teaching, and the work of a magician — the creation of an illusion, are closely related. The magician's task is to create an emotionally engaging situation and atmosphere and guide the viewer to focus on the inessential; the aim of a teacher — or the computer or network teaching application in this project — is to guide a student or group of students to see, do and discover what is essential in the focal content and to create an emotionally appropriate context for that learning. We might say that both the teacher and magician try to guide observations and emotions



and use different tools to that end. Adapting Galperin's terminology, we can refer to this guiding of observations in appropriate or inappropriate directions as orientation (e.g., Galperin 1979; Podolskij 1997).

In using various computer and network-based learning tools, such as the simulations in electronic technology and electronics used in the present project (e.g., Lehtonen 2002a,b,c), the observations presented above on steering the student or group of students are at least as salient as they are in conventional teaching. The activity which students are guided to engage in through teaching – study (Uljens 1997) will frequently not take place in an optimal fashion solely by using the most modern tools; we must at the same time guide or orient the student to use those tools in a manner appropriate for studying. Indeed, although the terms used in teaching have changed in many particulars to the more modern-sounding “learning”, the problem of teaching and guiding is still very much with us. Although we speak of constructive learning, for example, teaching itself, guiding and focusing students' studying, i.e., orienting them towards what is essential has by no means disappeared. The following sections provide an exploration of the theoretical key ideas and their implications for guiding students on network-based group learning situations with simulations.

## **2. SIMULATIONS AND MODERN AND TRADITIONAL MEDIA AS A NATURAL PART OF THE STUDYING PROCESS**

The aim of this article is to present the underpinnings of the learning activity that is being elaborated in the action research project “Web-supported Mental Tools in Technology Education” (N=9, third- and fourth-year preservice teachers on a technology education course). These principles allow simulation tools, modern network-based solutions that support learning, and other mental tools (e.g., Jonassen 2000), as well as traditional and modern digital learning materials, to be smoothly integrated into normal teaching-studying-learning activity in typical university-level study. The project has undertaken to analyze the advantages and disadvantages of different tools and media, and the aim has been to use these in appropriate roles. Thus efforts have been made to use literature, electronic documents, interactive documents and different kinds of interactive tools, such as simulations, in a way that would maximize their benefits but minimize their disadvantages (e.g. Gonzales et al. 2001). For example, Min (1992) concludes that the use of written sources, books and handouts as parallel media along with a computer is often motivated, and no attempt has

been made to transfer all materials into electronic format. Min (1992) also submits that open simulation environments often work better when the instructions for their use include easily read and browsed (printed) documents, such as workbooks, alongside material on the computer display. Efforts have been made to produce and use content and documents, as well as tools, e.g., 'mindtools' (Jonassen, 2000), that facilitate thinking, which exploit the capabilities and interactive nature of the electronic medium, in this format. Preliminary research findings (simultaneous video and stimulated recall, group interview) support the effectiveness of this approach. A textbook and simulation in conjunction with an interactive WWW agent application to support them - an orientation agent - seem to work together as envisioned. Here the research has drawn on usability studies and the ideas of cognitive load theory; in other words, the study tools have been built to avoid students' having to divide their attention excessively among different focuses and activities, (e.g., Kapetilin & Nardi 1997; Wilson & Cole 1996; Sweller, J. & Chandler; Chandler & Sweller 1991). Efforts have also been made to exploit edutainment (*education & entertainment*) as part of the nature of tools and materials and game-like interactivity as factors that can enhance the learning process.

### **3. THEORY OF TEACHING AND LEARNING, INSTRUCTIONAL DESIGN AND TECHNOLOGY SUPPORTING ONE ANOTHER**

The project has sought to link its focus - graphic simulations in electronic technology and electronics - in a theoretically justifiable way to the teaching-studying-learning process defined by Uljens (1997) in order to provide for a studying process that would produce high-level learning. (cf. Gokhale 1996).

The teaching has been designed to orient the student's studying and learning activity as an individual and a member of group, i.e., small groups towards Vygotsky's zone of proximal development (ZPD) using instructional design solutions and information technology (Lehtonen 2002; Ruokamo et al. 2002; Vygotsky 1978/1932; Wertsh 1985; Bransford et al. 2000, 214-215). The aim has been to create a process in which the topic being studied and the related sub skills and knowledge are constructed in the group process. In the initial stage of the process, students engage in network-guided activities in which they externalize, communicate and visualize their ideas to others through speech, simulation tools and gestures as well as test the viability of their ideas using a simulation tool. In this way, the topics are

gradually internalized (Galperin 1979; Podolskij 1997) and it becomes possible to gradually reduce the guidance, or orientation, of study, ultimately permitting the testing and application of what has been learned in a problem-based project. Drawing on Vygotsky (1978/1932), the social interaction among the students occupies a central role in the instructional design model. The guidance tools and their effect remain at the student's and group's disposal throughout the process (book and orientation agent) should they wish to resort to them. This can be considered extremely important, not only for guidance of the student but also as an element which can give the student a sense of security and reduce situational anxiety, thereby contributing to learning (e.g., Farnill 2001; Min 1992; Bransford 2000). Preliminary analyses of the research data support this conclusion. When the subskills that have been mastered following the process described above, and different subskills practiced, and the students' knowledge of electronic technology and electronics has developed sufficiently, learning activity can continue with an open, problem-based period in which the students must not only test their knowledge and acquire new knowledge but also apply what they have learned during the first stage of the teaching.

The guiding/orienting function of this first stage is very important in light of the tools used in the present research, e.g., simulation programs for electronics incorporating open-ended problem solving. Jonsassen (2000, 156) observes, "[the tools] enable learners to represent their own thinking in the ways that they explore, manipulate and experiment with the environment" (cf. Gokhale 1996). However, Gonzales, Reitman & Stango (2001) point out that one problem associated with tools that make use of open problem solving is that without teaching, learning and sufficient practice in the use of the tool itself (sufficient control of the tool) and without experimenting with and study of the tool in problem solving thereafter as well as acquisition and building up of sufficient knowledge and skills in the subject concerned as part of studying, the tools lead to superficial and game-like study activity which rarely results in high-level learning. Here, one may refer to Podolskij's (Podolskij) statement, based on neo-Galperinian theory, that only when a learner has been helped to internalize certain routine activities and these no longer place an undue cognitive load on his/her thought and activity should he/she have the opportunity to be given asks requiring creativity, such as open problem-solving tasks. For this reason the teaching described has been designed to include orientation as Galperin describes it, which seeks to ensure that subject matter is learned gradually and that, at the same time, the students have an opportunity to regulate the orientation and support offered to them in accordance with their needs to the minimum possible but to nevertheless

keep these available should the student want to resort to them. (cf. Ausubel's *Advance Organizers* and Bruner's *Scaffolding*)

#### **4. GAMES AND EDUTAINMENT AS PART OF STUDYING**

In order to be interesting, the tools should also produce experiences and feelings, direct and strongly supported teaching, which is often necessary early in learning. Jonassen (2000) in fact observes that these strongly interactive tools motivate students precisely because the tools allow them to learn by doing instead of contenting themselves to watch and listen to a presentation of how the thing is done by someone else. (cf. Bransford et al. 2000). One's own activity and work as part of a group often involves emotions and experiences. Edutainment has a contribution to make here in that the computer does not lose its significance as a tool; rather, its distinctive features are augmented to produce emotions in and entertain the user (e.g., Kangas 1999; Ruokamo et al. 2002). Crawford (1984) notes, that the principal motivation for playing is a desire to learn – a desire to learn to control a situation. He maintains that the desire to play is a mechanism that is built into one and us which the designers of computer games make use of. For example, ramping levels of difficulty, immediate feedback, and the use of multimedia to produce different effects are some of the means by which these experiences are created in computer games.

The present research attempts to accommodate the requirement of edutainment through its choice of a commercial simulation. The simulation software chosen for the research from among a number of potential applications has proven to be a successful one in many respects.

#### **5. CONCLUSION**

In light of its current findings, the research project "Web-supported Mental Tools in Technology Education" has made it possible to test the theoretical bases described and thus yielded valuable information on how study using simulation tools and network applications that support these and more traditional media can be appropriately organized. A preliminary analysis indicates that P. J. Galperin's ideas of the gradually and guided internalization of relevant sub skills by guiding the process through different orientation phases seems to work in a network environment. The importance of taking edutainment into account in designing instruction also seems to be

borne out. The final analysis will also produce a great deal of knowledge in this area, but at this stage in the research, where materials are being organized and analyzed, it is not possible to present more specific conclusions.

## REFERENCES

- Bransford, J., Brown, A.L. & Cocking, R.R. (Eds.) (2000). *How people learn*. Washington, D.C.: National Academy Press.
- Chandler, P., & Sweller, J. (1991). Cognitive load theory and the format of instruction. *Cognition and Instruction*. 8, 293-332.
- Crawford, C. (1984). *The art of Computer game design*. Berkley, USA: McGraw-Hill.
- Farnill, D. (2001). *Communication in a medical emergency*. Dept of Behavioural Sciences. University of Sydney. Retrieved February 12, 2003 from <http://www.gmp.usyd.edu.au/vguide/students/samplew/mscp/learningtopics/Kk9HHkf.htm>
- Galperin, P.J. (1979). *Johdatus psykologiaan*. Suom. Riitta Kauppila, Klaus Helkama Helsinki. Kansankulttuuri.
- Gonzales, J. J., Reitman, L. & Stagno, T. (2001). *An Interactive System for Teaching Electronics*. Seminar paper presented at the 2001 ED-media conference, Tampere. June 25-30. 2001.
- Gokhale, A. 1996. Effectiveness of Computer Simulation for Enhancing Higher Order Thinking. *Journal of Industrial Teacher Education*. 33(4), 36-46. Retrieved February 12, 2003 from <http://scholar.lib.vt.edu/ejournals/JITE/v33n4/jite-v33n4.gokhale.html>
- Jonassen, D.H. (2000). *Computers as mindtools for schools. Engaging critical thinking*. (2nd ed). NJ. Prentice Hall.
- Kangas, S. (1999). Mukautuvat käyttöliittymät elektronisissa peleissä. In T. Honkela (Ed.), *Pelit, tietokone ja ihminen. [Games, Computers and People]*. (pp.128-134) Suomen tekoälyseuran julkaisuja. Symposiosarja No 15. University of Art and Design UIAH & Finnish Association of Artificial Intelligence. Helsinki
- Kapetelinin, V. & Nardi, B.A. (1997). *Activity Theory: Basic Concepts and Applications*. Retrieved February 12, 2003 from <http://www.acm.org/sigchi/chi97/proceedings/tutorial/bn.htm>
- Lehtonen, M. (2002a). Toward the Information Age Challenges in Technology Education. Modern learning methods & learning media supported and mediated learning processes as part of the new university technology education curriculum. In J. Kantola., & T. Kananoj (Eds.), *Looking at the Future: technical work in context of technology education*. (pp.99-119) University of Jyväskylä: Jyväskylä University Printing House.
- Lehtonen, M. (2002b). *Simulaatioiden avulla tapahtuvan oppimistoiminnan mallin ja sitä tukevien Web-pohjaisten välineiden kehittäminen teknisessä työssä ja teknologiakasvatuksessa*. Paper presented at the 2002 ITK'02 Conference Workshop of Researchers. Ministry of Education and the University of Tampere Hypermedia Laboratory. 17.4.2002. Hämeenlinna, FI
- Lehtonen, M. (2002). *The Online Interactive Curriculum Portal as One Key to the Well-Structured Learning Activity of Students*. World Conference on Educational Multimedia, Hypermedia and Telecommunications. 2002(1), 1110-1115. [Online]. Available: <http://dl.acee.org/10288>

- Min, F.B. (1992). Parallel instruction, a theory for educational computer simulation. *Interactive Learning International*, 6(3), 117-183.
- Podolskij, A. (1997). Instructional Design for Schooling. Developmental Issues. In S. Dijkstra et al. (Eds.) *Instructional Design. International perspectives*. (Vol. 2). Mahwah, NJ: Lawrence Erlbaum.
- Vahtivuori, S., Ruokamo, H., Tella, S., & Tuovinen, H. (2002). Pedagogical Models in the Design and Assessment of Network-Based Education. *World Conference on Educational Multimedia, Hypermedia and Telecommunications*. 2002(1), 1676-1681. [Online]. Available: <http://dl.aace.org/10418>
- Sweller, J., & Chandler, P. (1994). Why some material is difficult to learn. *Cognition and Instruction*, 12, 185-233.
- Uljens, M. (1997). *School didactics and learning*. Hove, East Sussex: Psychology Press.
- Wertsch, J. V. (1985). *Vygotsky and the social formation of mind*. Cambridge, MA: Harvard University Press.
- Wilson, B. & Cole, P. (1996). *Improving Traditional Instruction. Cognitive Load Theory*. Retrieved February 12, 2003 from <http://carbon.cudenver.edu/~bwilson/cog/sweller.html>
- Vygotsky, L. S. (1978/1932). *Mind in Society*. Cambridge, Massachusetts. Harvard University Press.

## **BIOGRAPHY**

Miika Lehtonen is researcher at MOMENTS (*Models and Methods for Future Knowledge Construction: Interdisciplinary Implementations with Mobile Technologies*) project. His research and development has recently focused on developing pedagogical models and tools for network-based learning utilizing the Vygotskian and neoGalperian ideas of 'mental tools' or 'mindtools' and Web based pedagogical agent orientation (cf. Jonassen 2000). His main interests lie at the area of using interactive & constructive simulations effectively as mental tools for learning.

*Miika Lehtonen University of Lapland, Faculty of Education, Centre for Media Pedagogy  
P.O. Box 122, FIN-96101 Rovaniemi, FINLAND*

*Miika. Lehtonen@urova.fi*

*<http://www.urova.fi/home/hkunta/milehton>*

*<http://amc.pori.tut.fi/moments>*



# **E-TRAINING OR E-LEARNING?**

*Towards a synthesis for the knowledge-era workplace*

Paul Nicholson

*Deakin University Australia*

**Abstract:** Many E-training environments and processes are based on participatory learning models in which participants share their understandings and aim to develop new insights into their workplace knowledge through discussion, questioning, mentoring and personal reflection. Knowledge production is assumed to occur through the cumulative effect of these actions. However, equally likely outcomes include the sharing of ignorance or the development of erroneous understandings. Cognitive and social views of learning posit, however, that humans learn by thinking (not just by interacting), and that unless this is explicitly taken into account in developing training programs, optimal learning outcomes may not be achieved. This paper examines the importance of incorporating cognitive and social-learning perspectives in E-training environments in order to maximise the potential for optimal learning to occur, and provides suggestions for a synthesis of participatory and cognitive models.

**Key words:** learning models, cognition, collaborative learning

## **1. FOUNDATIONS**

The Western schism between ‘teaching’ and ‘training’ arose from differing epistemological and philosophical positions extant in school and workplace education. These have manifested themselves in models of pedagogy and andragogy respectively (Knowles, 1980). There is an implicit notion that pedagogy and andragogy are almost mutually exclusive constructs — a position now being challenged as educators and trainers strive to achieve the common goal of developing effective E-learning or E-training programs. In the workplace, this has forced trainers to address ‘educational’ issues such developing higher-order thinking, and working



outside of competency-based paradigms. It has also forced teachers and planners to view learning as a life-long process that needs better links between school and workplace learning.

Many E-training environments and processes that are not competency-driven are based on learning models, such as Action Learning (Revens, 1979), in which participants share their understandings and aim to develop new insights into their workplace knowledge through the *actions* of discussion, questioning, mentored and personal reflection — the production of knowledge is assumed to occur through the cumulative effect of these actions. Action Learning is an example of a participatory learning model (PLM) in which learning comes from active participation in a learning process. How new, as opposed to recontextualised, knowledge arises in this model is problematic. There is little inherent certainty in such an approach as equally likely outcomes include a sharing of ignorance and the development of erroneous understandings.

Cognitive learning models (CLM) posit, however, that humans learn by thinking, not just by interacting, and that unless this is *explicitly* taken into account in developing training programs, optimal learning outcomes may not be achieved. CLM are characterised by *an acquisitive metaphor of learning, in which individuals acquire and accumulate concepts* that are basic knowledge units to be acquired and refined over time.

Action Learning models *could* include *explicit* cognitive elements, but they usually don't. They almost exclusively assume that cognitive facilitation will occur serendipitously through the 'action' of interacting with other participants and through mentoring, rather than explicitly providing mechanisms for it to occur. The 'knowledge-era' paradigm and its associated notions of life-long learning have challenged these long-standing traditions.

The following sections provide an exploration of these implications of these issues for a holistic design approach that embraces both training and learning models as currently conceived. Finally a model is proposed that provides a new focus for instructional design.

## 2. A NEW SYNTHESIS?

Many contemporary Western E-learning pedagogies are based on a variety of social-learning models that emphasise the importance of context, situation and the social construction of knowledge through collaborative processes (e.g., Guzdial & Kehoe, 1998; Nicholson & White, 2001). They often have superficial similarities to Action Learning, but in these newer models, new understandings are taken to develop through the purposeful

socially-mediated development of cognitive processes (e.g., Wu, Farrell, & Singley, 2002). These differ from CLM because they allow for socially constructed and mediated understandings, and accept that understanding develops in context and culture, rather than as the acquisition of predefined concepts (cf. CLM). For the purposes of this paper, they will be referred to as social-learning models (SLM).

While our understandings of learning have developed rapidly, this is not true about our understandings of ‘training’. For example, many contemporary training materials that are developed from andragogical action-oriented perspectives fail to explicitly address ‘learning’ issues — whether cognitively, collaboratively or socially constructed — as a central part of their design (cf. Anderson, Greeno, Reder, & Simon, 2000) though they often address them in peripheral ways. A common example is the confusion (or misconception) of the process role of mentors or facilitators with that of providing cognitive facilitation.

There is no argument that learning models that are not explicitly focused on cognitive issues may serendipitously lead to rich cognitive learning outcomes — indeed it would be worrying if this were not so — but rather, that because they often lack specific strategies and features to facilitate cognitive development, they are sub-optimal designs for effective training (and learning) – especially when the desired outcomes include addressing the kinds of complex and super-complex issues (Barnett, 1999) facing many organizations today (Zuboff, 1988). The kinds of cognitive competencies required of workers in such organizations include the ability to:

- analyse claims, opinions and complex situations;
- make critical judgements of alternative views;
- evaluate and synthesise a variety of positions into a coherent whole;
- meet strategic challenges facing their organization.

In the 1990’s these were deemed to be solely the province of so-called knowledge workers, but as the knowledge-era paradigm has become better understood, they are increasingly seen as being essential competencies for all life-long learners. The related belief that acquiring these kinds of cognitive competencies need to be addressed in both school and workplace contexts, blurring the distinction between training and learning. Operationalizing this notion requires that both learning and training be reconceptualized as part of a continuum, with a common knowledge base.

Many contemporary E-learning and E-training programs adopt a passive view of learning and focus on individual learning, rather than as interactive and engaging — important attributes for the promotion of higher order learning. Likewise, in the case of Action Learning, many of its processes mimic social-learning models, but fail to explicitly address cognitive learning issues. In both cases, a refocusing on the attributes of the

underpinning learning model can allow cognitive perspectives (e.g., a focus on higher-order thinking) to be included. However, this does not mean that this is a ‘simple’ process, because in both cases there are significant implications as to the ways in which the delivery of the program, and learning support have to be resourced and organised.

A blended solution, in which purposeful cognitive strategies support interactive and social learning (e.g., Nicholson & White, 2000, 2001, 2002), is an essential precursor for maximising the potential for optimal learning and training to occur, particularly when the focus is on the higher-order thinking and understanding of complex ideas discussed above (e.g., Lally & De Latt, 2002). There are clear pathways for incorporating aspects of CLM in participatory training program models — to simply add particular elements such as cognitive scaffolding. However, maintaining a differentiation between learning and training in a knowledge-era context may be pointless from both epistemological and design perspectives.

With the increasing focus of E-training on knowledge-era workplace issues, and of E-learning on real-world contexts, we can expect to see a convergence of models (Figure 1) as they both attempt to achieve similar kinds of outcomes (e.g., higher-order thinking) but in different contexts and with differing degrees of generalisation or specificity.

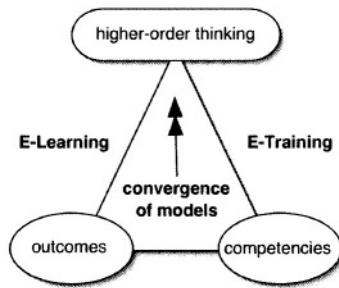

Figure 1. Convergence between E-learning and E-training models with change in focus to higher-order thinking

Arguably, in a genuine knowledge-era context, there would be no difference between them except, perhaps, for competency-based programs that might by their very nature serve to perpetuate an underlying differentiation. This suggests that there should be a new, or perhaps renewed, emphasis on developing effective learning models for both school and workplace learning, with the essential differentiation being in the context rather than the methods used to achieve learning outcomes, i.e., that

cognitive aspects of learning should be central to both education and training models.

This is not to argue against adult-learning models and andragogy, or to reject the need for child-centred pedagogies, but rather to suggest that it would be more fruitful to regard them as one aspect of life-long learning, and to attempt to articulate a more holistic range of conceptually coherent models of learning within a life-long learning framework. There are many barriers to be overcome before any such solution is possible. Some will be due to institutional and corporate inertia, but the biggest barrier will be overcoming deeply enmeshed epistemological and philosophical positions.

### **3. ESSENTIAL FOCI FOR PROGRESS**

In order to move forward on the issues raised above, it is necessary to provide guidelines to both educators and training developers that can (a) accommodate their differing contexts and (b) provide an overarching conceptual model that can be applied to developing holistic life-long learning strategies and synergies. In order to accomplish this, there are at least three essential educational and theoretical foci that must be explored, in order to inform the effective implementation of such a program:

1. Developing adaptive designs for social learning contexts.
2. Defining the attributes of rich environments for active, socially mediated collaborative learning environments.
3. Developing explicit scaffolding mechanisms, models and standards.

These three foci are meta-level tasks that require significant insight into a range of theoretical and practical considerations. The following discussion explores some key dimensions of each in order to provide some insight into their nature.

#### **3.1 Designing for social learning**

In addressing the issue of identifying adaptive social-learning models, it's helpful to have an appropriate conceptual meta-framework such as the layered-design model in Figure 2. (Nicholson & White, 2001)

Its purpose is to shift thinking about E-learning and E-training development away from technical and process considerations (such as structuring learner interactions) to focusing on the learners' development of expertise in a rich environment for active learning. The design 'layers' are intended to focus attention on four separate, and essential, foci:

- a) technical aspects of the design;

- b) the nature and purposes of the ways in which learners will interact with the course content, other participants, and external individuals;
- c) the pedagogical structures and processes that will build upon the interactions to develop expertise in the particular learning context;
- d) the culturally sensitive and authentic assessment processes that need to be developed to ensure the attainment of expertise can be evaluated in a meaningful, as opposed to simplistic, manner.

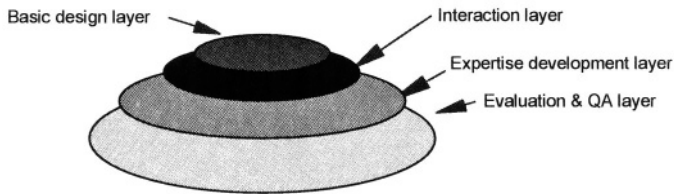

Figure 2. Layered design model for E-Training. (Nicholson & White,2001)

By including expertise as a design element, and by differentiating it from technical design and learner interaction, it allows learners' needs and contexts to be paramount and accommodated in developing learning designs. It also facilitates the possibility of accommodating socio-cultural elements as a central design feature. For example, a 'standard' online unit built in, say, WebCT might be implemented at the design level as a set of files, organisers and links according to some predetermined instructional model and pedagogical design. Traditionally this constitutes the design process, with the student interacting with content by email or discussions.

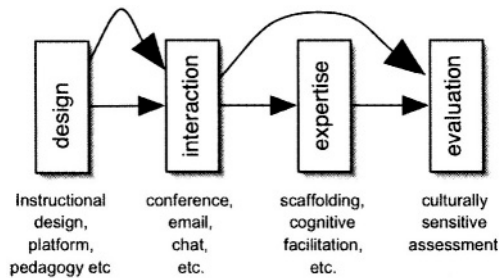

Figure 3. Relationship of design layers to learning sequence. Most E-learning courses bypass the expertise development layer as indicated by the top sequence of arrows.

The top arrows in Figure 3 indicate this learning pathway. In this pathway there is no engagement with the expertise layer, which is where cognitive facilitation, socio-cultural elements, and perhaps other aspects such as learning styles would be accommodated. This shows that E-learning designs may easily overlook the need for developing expertise unless it is an explicit design element. However, a focus on culturally sensitive expertise is arguably the most critical design element of all, and the area in which there are the least theoretical and practical guidelines to shape research and development.

Simply planning structures and processes such as learning sequences, discussions, and online seminars to engage learners with content is insufficient to facilitate higher order thinking. In this model, most of what occurs in action learning programs is located in the interaction ‘layer’. For example, in the absence of explicit cognitive strategies in action learning, the mentors and facilitators’ inputs into the groups’ learning would be regarded as largely ‘interactive’ – providing direction and reacting to learners, but not necessarily focused on explicit cognitive development. By decoupling interaction from learning (i.e., the development of expertise), it is easier to focus on nature of cognitive facilitation as an element of expertise development, and the need to address it in practice.

### **3.2 Scaffolding**

Scaffolding refers to helping learners tackle cognitive issues they could not address in its absence—to move through their zone of proximal development (Vygotsky, 1978). Little has been done in this area in E-learning or E-training contexts, and as it is at the heart of cognitive facilitation, there is a need for urgent research and development to create scaffolding toolkits—repertoires of diagnostics, strategies, tools, and tactics to support learners overcome their hurdles. There is a real need to see how scaffolding techniques might need to be adapted to different stages of life-long learning, and also how effective classroom practices might be adapted to the needs of industrial contexts. In particular, there is an urgent need to develop standards-based learning objects for scaffolding. Without agreed standards and a related ontology, development in this area will remain fragmented.

## **4. CONCLUSION**

A convergence of training and learning models, and major changes to the nature of educational and training institutions, can be expected to occur as the ramifications of the knowledge-era paradigm impact on society. An

effective response to these changes requires a cross-domain understanding of a range of technical, educational and psychological factors. The three foci presented in this paper are critical areas in which to commence a systematic response to these presumed challenges.

## REFERENCES

- Anderson, J. R., Greeno, J. G., Reder, L. M., & Simon, H. A. (2000). Perspectives on Learning, Thinking and Activity. *Educational Researcher*, 29(4),11-13.
- Barnett, R. (1999). Learning to work and working to learn. In D. G. Boud (Ed.), *Understanding learning at work*. London: Routledge.
- Guzdial, M., & Kehoe, C. (1998). Apprenticeship-based learning environments: A principled approach to providing software-realized scaffolding through hypermedia. *Journal of Interactive Learning Research*, 9(3/4), 289-336.
- Knowles, M. S. (1980). *The modern practice of adult education: From pedagogy to andragogy* (2nd ed.). New York: Cambridge Books.
- Lally, V., & De Latt, M. (2002, Jan 7-11). Cracking the code; Learning to collaborate and collaborating to learn in a networked environment. *Paper presented at the CSCL conference on Foundations for a CSCL community*, Boulder, CO.
- Nicholson, P. S., & White, G. (2000, September 5). Rich environments for active learning. *Paper presented at the Australian Institute for Training and Development seminar on Adult Learning*, Melbourne.
- Nicholson, P. S., & White, G. (2001). Teaching for Quality Learning Online: A layered Design Model for Higher-order Thinking. In D. Watson & J. Andersen (Eds.), *Networking the Learner: Computers in Education, IFIP World Conference on Computers in Education, WCCE 2001* (pp. 49-58). Dordrecht: NL: Kluwer Academic Publishers.
- Nicholson, P. S., & White, G. (2002). A framework for facilitating higher-order strategic thinking in online management development. In R. Tranmuller (Ed.), *Information Systems: The E-Business Challenge* (pp. 199-207). Dordrecht: NL: Kluwer.
- Revans, R. W. (1979). *The Nature of Action Learning. Management Education and Development*, 10(1).
- Vygotsky, L. S. (1978). *Mind in Society*. Cambridge: Harvard University Press.
- Wu, A., Farrell, R., & Singley, M. K. (2002, Jan 7-11). Scaffolding group learning in a collaborative environment. *Paper presented at the Computer-supported Collaborative Learning conference on Foundations for a CSCL community*, Boulder, CO.
- Zuboff, S. (1988). *In the age of the smart machine: the future of work and power*. New York: Basic Books

## BIOGRAPHY

Paul Nicholson has research interests in the design and use of ICT-based quality learning environments for developing higher-order thinking and in promoting quality learning. Recent research and development has focused on developing models of intelligent E-learning environments, on implementing quality online learning programs for executive management

development in global corporations and contexts and the design of culturally inclusive online learning materials.





# PEDAGOGICAL MODELS IN NETWORK-BASED EDUCATION

Sanna Vahtivuori-Hänninen

*Media Education Centre, University of Helsinki, Finland*

**Abstract:** This paper discusses an ongoing project which aims to examine the collaborative and game-based pedagogical models underpinning network-based education (NBE). These models are derived from didactic and pedagogical thinking on teaching–studying–learning (TSL) process. The research design is based on a qualitative approach, complemented with ethnographic study and participant observation in addition to thematic interviews and web-based questionnaires. The data of the study consists of two cases: 1) The national program on educational use of ICT study program in Higher Education and 2) The game-based simulations in NBE, which analyses how a collaborative and game-based models support TSL process in NBE. This paper briefly presents the background of the study and describes some preliminary findings of the teachers’ and students’ conceptions of NBE from the higher education case. The outcomes of the study will be pedagogical models and principles to be used when designing and assessing NBE.

**Key words:** learning models, collaborative learning, games, simulations

## 1. INTRODUCTION

The real challenge when developing network-based education (NBE) is to investigate how different pedagogical models function and support teaching–studying–learning (TSL) process in network-based environments. This paper presents four pedagogical models applied to NBE. The objective of the paper is to demonstrate the didactical and learning theoretical points in order to develop NBE and educational uses of ICT. The paper presents briefly the background and the empirical part of the study. The study encompasses two different case studies from higher education and working

life contexts. Also some pilot findings of the teachers' and students' conceptions of NBE from the higher education case will be discussed.

The study is part of the MOMENTS Project 'Models and Methods for future Knowledge Construction', which is a co-operative research project between Tampere University of Technology, Pori, the University of Lapland, University of Turku and the University of Helsinki. It is also part of the Academy of Finland 'Life as Learning' Research Programme.

## **2. TOWARDS PEDAGOGICAL MODELS IN NBE**

The theoretical background of the study falls within a social-constructivist and sociocultural framework. According to these conceptions, knowledge is not an objective reflection of the world around us that can be transferred as such, but rather, something constructed by individuals and the social community surrounding. (Vygotsky, 1978; Lave & Wenger, 1991; Vahtivuori et al. 2003.)

### **2.1 About Teaching, Studying and Learning Process**

The study emphasizes the pedagogical models that are inspired by, and partly based on, this sociocultural framework and which underpin collaborative and experiential modes of teaching, studying and learning (e.g., Sharan & Sharan 1992; Vahtivuori & Lehtonen 2003). These models are also derived from didactic and pedagogical thinking about teaching, studying and learning (Uljens, 1997; Kansanen et al., 2000). Uljens (1997) particularly emphasizes the process of teaching–studying–learning (TSL) as central for didactics and teachers' pedagogical thinking. According to him, both teaching and learning are important but equally important is studying. For this reason, we also need to examine teaching, studying and learning as equally important components.

These concepts are also seen as a fruitful way to organize, design and assess NBE and network-based environments. Especially the concepts of studying and *studybility* are in focus and are analysed and understood through the different implementations of NBE (Vahtivuori & Lehtonen 2003). These concepts include the concrete activities of the students, and the situation and circumstances in which study and activity take place.

## **2.2 Four Pedagogical Models**

This study analyses four pedagogical models which can be particularly useful in carrying out experiential, collaborative modes of learning and studying in network-based environments. (Sharan & Sharan, 1992; Joyce et al., 1997; Vahtivuori & Masalin, 2000; Vahtivuori et al., 2003).

The four models utilized in this study are the following:

- The group investigation model;
- The model of learning and teaching through game-based simulations,
- Model of the different uses of ICT;
- The integrated model of NBE.

The first pedagogical model used is the group investigation model (Sharan & Sharan 1992, 18). It is a holistic TSL model that can be defined as a collaborative learning model. The elements of this model consist of:

- investigation;
- interaction;
- intrinsic motivation;
- interpretation.

These elements are interrelated and simultaneously present. According to the group investigation TSL can be seen as a process of gaining expertise. This process of expertise acquisition requires social support. The model is one method in distributing amount of speech evenly among the students and teacher and creating new knowledge in social groups in network-based environments. In this study the group investigation model and its key principles have been combined with the second model, the model of learning and teaching through game-based simulations (Joyce et al. 1997, 130). This model has four phases:

- orientation;
- participant training;
- phase of simulation operations;
- debriefing of the simulation.

Both of the models described above have been used, especially when designing and implementing the case study ‘The game-based simulations in the guidance process of NBE’.

The third pedagogical model utilized is the model of the different uses of ICT, partly based on Goldsworthy’s (1999) lenses of learning. It deals with four categories that examine the relationships between studying and technology. This pedagogical model also includes the four overlapping categories of ICT use:

- pedagogical;
- instrumental;
- communicative;

– collaborative.

These categories describe the different uses of technology for facilitating and enhancing TSL process. The pedagogical use of ICT category refers to how learning can be facilitated by having content explicitly taught by a technical application or software package. The Instrumental use of ICT category refers to a common way of understanding the use of ICT in learning. It describes how ICT enhances an individual's capability and efficiency when learning and studying (Goldsworthy 1999, 59). Communal use of ICT represents a communal way of learning. Skills and content are learned through the structuring of the situation, where a group of students shares applications. Communicative use of ICT is in question when TSL process primarily occurs through the interaction of learners at a distance, as mediated by ICT, the learning may be considered as facilitated through technology (Goldsworthy 1999, 59–60). This is the classical distance education (DE) situation. (Goldsworthy, 1999; Vahtivuori & Masalin, 2001.) This model has been used especially when designing the thematic interviews of the teachers of the higher education case.

The fourth model used is a compilation of different pedagogical models that can be used when designing and assessing NBE. The model combines a variety of principles, characteristics and models of teaching and studying. The model is based on Uljens' (1997) thinking of TSL process. The integrated model has been elaborated during the Higher Education Case Study (Ruokamo et al., 2002; Vahtivuori et al., 2003) This combined model embraces the features and principles of i) reflective teaching, ii) purposive studying and iii) meaningful learning (Ausubel, 1968; Jonassen, 1995; Ruokamo et al. 2002). The combined pedagogical model and its features, that is, the concepts of the model, have been functioned as the classificatory outline of the data of the higher education case.

All of the models described here can be useful when analysing and developing NBE because they remind us of the complex roles and uses of ICT in TSL processes. They help us to identify the different uses and aspects better when designing NBE and network-based environments, and also to make reasonable choices. In the NBE, it seems vital to understand ICTs as tools and contexts to think of and to act with. If we are cognizant of these various models, their principles, different uses and roles of technology as designers and teachers, we can support the students' process of studying and learning in the best possible way and design good quality NBE and network-based TSL environments. (Vahtivuori & Masalin, 2001.)

### **3. COLLABORATIVE USE OF GAMES IN NBE**

According to the recent research, many skills can be learned through collaborative use of games and simulations in NBE, e.g. social communication and collaboration, problem solving, decision making, rules, visual and spatial ideas (e.g. Wigforss, 2003, p.24). As its best, a network-based course can be a multiplayer game, simulation, story or a narrative about an interesting subject. Network-based course or a study program can be an emotional experience. The central idea, a logically built game-based simulation through the course helps students and teacher combine things and same time motivate to carry on working. Games can take real advantage from narratives. Simple text based narrative materials and games can be designed even for e-mail (Jasinski & Thiagarajan 2000). With games and simulations, real experiential studying and learning can be created. Immersion of the game and game-based thinking and activity makes action in the network-based environment more experiential. Also, the level of interactivity and communal modes of studying can be increased (e.g. Tella et al. 2001). The creation of experiences in NBE seems to be at least as important as in face-to-face TSL process (Ackermann 1994; Jonassen 1995; Boud & Feletti 1997; Vahtivuori 2001). It seems that with the aid of role games and simulations, collaborative, experiential and problem-based learning contexts can be created, and make virtual “hands-on” sessions possible more and more in the NBE. (Vahtivuori & Masalin, 2001)

### **4. RESEARCH TASKS AND QUESTIONS**

The above theoretical discussion will lead to several research areas that are divided into the following research questions:

- How can the collaborative and game-based pedagogical models of NBE be perceived and function in higher education and working life contexts?
- What kind of design, quality, and assessment principles can be used and elaborated for NBE?
- What kind of functionalities and features does the guidance process demand from the network-based environment?

The concepts and design principles, which have a special emphasis in the study, are collaborative and experiential learning and studying. The concepts are examined and discussed especially in the case ii) ‘The game-based simulations in the guidance process of NBE’ where the group investigation model and the model of teaching and learning through game-based simulations have been used as a basis for designing and assessing NBE.

## **5. METHODOLOGY AND DATA COLLECTION**

The research design of study is based on a qualitative approach, complemented with ethnographic study. In the addition of the participatory observation (web discussions, video conferences and face-to-face meetings) and collection of textual groupware-based data, the data are also collected with web questionnaires from students (N=83) and thematic interviews of the teachers (N=11). The study aims at dialogic and communal action and developmental research, where a researcher is actively involved in the designing and implementation of the TSL process in NBE.

The data of the study consists of two case studies. In the spring 2003, the study has been concentrating a higher education case (N=55), which is part of the national program on Educational Use of ICT of the Finnish Virtual University of Educational Sciences (KasVi) and The Helsinki-Lapland Educational Use of ICT Programs Evaluation Project (HelLa). The general aim of the higher education case is to study, develop, and assess how higher education training programs relate to educational use of ICT and can create good quality NBE. (Ruokamo et al., 2002; Vahtivuori et al., 2003.)

The working life case has been implemented in the summer 2003. This case analyzes how a collaborative and game-based working and learning environment supports the TSL process, especially from the viewpoint of the guidance process. The data of the working life case is gathered from the leadership training course of the Finnish Defence Forces for young officers (N=28). This case study focuses on analyzing how a game-based and collaborative network environment should be designed in a purposive way and what kind of pedagogical guidance models will support purposive studying (Vahtivuori & Lehtonen 2003). These questions will be answered by analysing the students' action and the teachers' guidance process. This case study is also conducted in line with a business partner's R5 Vision product development process. Special emphasis will be laid on the pedagogical functionalities, features and tools for the guidance process in NBE. The content analysis is used to analyse the text data of the both case studies.

## **6. CONCLUSION**

The pilot findings from the higher education case focus teachers' and students' conceptions on teaching and studying and guidance process in the network environment and the principles of design and assessment. The findings of the case shows that teachers in NBE seem to design and act in more theoretical level than in face-to-face teaching and guidance situation.

NBE seems to demand more from the designing phase than face-to-face to situation. According to the teachers the exploratory teaching and problem-based and also reciprocal and collaborative teaching were the most commonly used pedagogical models among teachers of the course. According to the questionnaire, the students' opinions mostly support this finding. Almost the half of the students found that the ethos of the course was problem-oriented. Teaching and guidance had also a more significant role for both teachers and students than in face-to-face TSL process. (Vahtivuori 2003) The instrumental and communicative uses were the most central ways of using network-based environment to support TSL process. The data of the working life case study will be analysed in the autumn of 2003.

The paper has discussed how NBE could be designed in TSL processes. The object is to summarize and further develop the collaborative and game-based pedagogical models for NBE. The higher education ICT course and working life leadership training course provide a versatile opportunity to experiment with different implementations of NBE that can be tested against the pedagogical models and the principles of design and assessment. The outcomes of the study will be theoretical pedagogical models and practical principles, which will help teachers and students to teach and study in network-based environments. The study will contribute to the use and the development of novel teaching, studying and learning and working methods of NBE in higher education and working life contexts.

## REFERENCES

- Ackermann, E. (1994). Direct and Mediated Experience: Their Role in Learning. In R. Lewis & P. Mendelsohn, (Eds.) *Lessons from Learning*. Amsterdam: North Holland.
- Ausubel, D. (1968). *Educational psychology: A cognitive view*. New York: Holt, Rinehart & Winston.
- Boud, D. & Feletti, G. (Eds.) (1997). *The Challenge of Problem-based Learning*. Kogan Page.
- Goldsworthy, R. (1999). Lenses on Learning and Technology: Roles and Opportunities for Design and Development. *Educational Technology*, July–August 59–62.
- Jasinski, M. & Thiagarajan, S. (2000). Virtual Games for Real Learning: Learning Online with Serious Fun. *Educational Technology XL* (4), July–August 61–63.
- Jonassen, D. H. (1995). Supporting Communities of Learners with Technology: A Vision for Integrating Technology with Learning in Schools. *Educational Technology*, July–August, 60–63.
- Joyce, B., Calhoun, E. & Hopkins, D. (1997). *Models of learning tools for teaching*. Buckingham: Open University Press.



- Kansanen, P. et al. (2000). *Teachers' Pedagogical Thinking. Theoretical Landscapes, Practical Challenges*. American University Studies Series XIV Education, Vol. 47. New York: Peter Lang.
- Lave, J. & Wenger, E. (1991). *Situated Learning: Legitimate Peripheral Participation*. New York: Cambridge University Press.
- Vahtivuori, S., & Lehtonen, M. (2003, 28 June–1 July). *Use of Game-Based Simulations in the Teaching-Studying-Learning Process in the Framework of Multidisciplinary Model of Network-Based Education*. Paper presented at the 11th International PEG Conference, Powerful ICT Tools for Teaching and Learning, St. Petersburg, Russia.
- Vahtivuori, S., Ruokamo, H., Tella, S., & Tuovinen, H. (2002). Pedagogical Models in the Design and Assessment of Network-Based Education. *World Conference on Educational Multimedia, Hypermedia and Telecommunications 2002*(1), 1676-1681.
- Sharan, S. & Sharan, Y. (1992). *Expanding Co-operative Learning through Group Investigation*. New York: Teachers College Press.
- Tella, S., Vahtivuori, S., Vuorento, A., Wager, P. & Oksanen, U. (2001). Verkko opetuksessa – opettaja verkossa. (*Net in Teaching – Teacher in the Net*). Helsinki: Edita.
- Uljens, M. (1997). *School didactics and learning*. Hove, East Sussex: Psychology Press.
- Vahtivuori, S., & Masalin, T. (2001). Challenges in Designing Communal Web-Based Learning Environments. *World Conference on Educational Multimedia, Hypermedia and Telecommunications. 2001*(1), 1924-1929.
- Vahtivuori, S., Tuovinen, H., Tella, S., Ruokamo, H., Tissari, V., & Vaattovaara, V. (2003). First Evaluations of Network-Based Education: Preliminary Findings of the ICT Programs Evaluation Project. *World Conference on Educational Multimedia, Hypermedia and Telecommunications. 2003*(1), 3177-3184
- Vahtivuori, S. (2003). Teachers' and Students' Conceptions about Teaching and Guidance Process in the Network-Based Learning Environments. In T. Järvinen, T. & J. Levenon, (Eds.) *Proceedings of Interactive Technology in Education. The Researchers' Meeting of the ITK '03 Conference*. Tampere University: Hypermedialab.
- Vygotsky, L. S. (1978). *Thought and Language*. Cambridge, MIT Press.
- Wigforss, E. (2003). Role of Computer Games in Learning to Learn. In H. Turunen, M. Kariluoto & M. Myllylä (Eds.) *Conference Proceedings of Interactive Technology in Education ITK '03 Conference*. (p.25). Hämeenlinna, Finland.

## BIOGRAPHY

Sanna Vahtivuori-Hänninen (sanna.vahtivuori@helsinki.fi) is a researcher at the Media Education Centre of the Department of Teacher Education, University of Helsinki. Her research interests and developmental work deal with pedagogical models and design and assessment of network-based education. Her recent research has been focused on different uses of ICT in teaching, studying, learning processes, and collaborative and experiential modes of studying and learning in different higher education and working life contexts.

# **THE EFFECTS OF IT-BASED TRAINING ON EMPLOYEES UPTAKE OF NEW TECHNOLOGIES IN THE WORK-PLACE**

Lena Mae Wilkinson and Margaret Cox  
*Kings College London, UK*

**Abstract:** This paper reports on Phase 1 of a project that investigates the personal and institutional factors influencing the effectiveness of information technology based training on the uptake and integration of IT in the work-place. The results show that personal factors such as attitudes towards IT and confidence in using it affect the trainees' abilities and willingness to use it in the work place. Institutional factors, such as the organization and delivery method of the training, the understanding of the trainee's needs and the design of the training programmes have been shown to limit the effectiveness of the training. The personal factors in the model are based on the Theory of Planned Behaviour, and the institutional factors have been identified from previous empirical evidence. Both have been adjusted to accommodate the results of Phase 1.

**Key words:** IT-based training, training models, needs assessment, research, evaluation.

## **1. INTRODUCTION**

During the past three decades, Information Technology has pervaded all levels of private and public sector organizations (Harrison, Mykytyn, & Riemenschneider, 1997, Leidner & Jarvenpaa, 1995, Wishart & Blease, 1999). According to Roberts and Henderson (2000), by the year 1999 the penetration of IT in the workplace in the United States was approaching a ratio of one computer per person. However, although organizations spend approximately \$20 billion dollars each year on computer-related training, only 10% of training leads to a change in employees' work practices (Venkatesh & Speier, 2000). Previous research provides evidence of employees developing a positive attitude towards IT (Nordenbo, 1990),

being confident and liking working with computers (Roberts & Henderson, 2000), and preferring a highly interactive and motivating computer training program (Leidner & Jarvenpaa, 1995, Kettanurak, Ramamurthy, & Haseman, 2001). Agarwal, Prasad, and Zanino (1996) found that users perceptions are good predictors of attitudes towards the use of IT, and individual differences contribute to training experiences and perceptions. However, according to Torkzadeh and Van Dyke (2002) and Chou (2001), more substantial research still needs to be conducted to measure the effects of individual and organizational factors on the effectiveness of IT-based training (IT-BT). This paper reports on Phase 1 of a research project that is investigating the personal and institutional factors which might contribute to the effectiveness of IT-BT and the integration of IT in the work-place.

## 2. APPROACHES TO IT-BASED TRAINING

For the purpose of this research, we have identified three types of IT-BT approaches; IT Specific, Applied, and Embedded. In the case of IT-BT (*IT-specific*) being studied in this research project, the trainees are learning how to operate a computer and also a particular IT package such as word-processing to use in the work-place. *Applied* IT-based means the use of an IT-based learning environment to teach particular skills and processes which may have no connection with using IT in the work-place (e.g. a role playing simulation to teach employees safety procedures). *Embedded* IT-based involves using bespoke packages to teach specific skills which may also be related to the software interface itself (e.g. training pilots to fly an aircraft using flight simulators).

## 3. NEEDS ASSESSMENT

In many of the previous investigations into the effects of IT-based training, there has been limited research into the ways in which organizations have assessed the training needs of their employees and how this assessment has thereby affected their training programmes (Salas & Cannon-Bowers, 2001). According to Arnold et al. (1995, p.309), 'organizational analysis is important because it links trainees' training activities and organizational aims and objectives together'. An effective needs assessment programme involves not only identifying training needs but other procedures which may make the organization function more efficiently, such as redesigning the job, changing the equipment, improving

recruitment and selection procedures, or providing job aids (Rossett & Gautier-Downes, 1991).

Whatever the method of training being used (e.g. lecturing, workshops, on-line learning) research has shown that it is important when planning training that the organization identify the trainees' and organizational needs (e.g. Goldstein & Ford, 2002). This can be done by examining plans and statements of policy and procedures, and by discussions with management, senior personnel, and employees in the organization. Venkatesh and Speier (2000) showed that there are still many limitations to the effectiveness of different IT-BT programmes.

The need for the use of theories which should underpin the design and evaluation of IT-BT was demonstrated by the research teams who were analysing the role functions of trainers for the TDLB (Training and Development Lead Body) Standards of Competence (Rae, 1995). The researchers reported that few effective approaches were observed. Also, there have been very few investigations reported in the literature, of the trainees' achievement of the learning objectives, their longer-term retention of knowledge, and their change in working practices. Specifically, there is little research evidence about the integrated relationship between the institutional and personal factors of IT-based training and the subsequent work practices of the employees.

#### **4. AIMS AND PHASES OF THE STUDY**

In order to study the effectiveness of IT-BT, our research involves investigating the personal factors relating to the trainees' experiences and changes in work practices, and the institutional factors relating to the organizational and management practices.

In Phase 1 of this study we conducted an extensive review of the IT-BT literature and investigated the context of the institution (involving 8 trainers and 185 employees), how the training was organized, the processes and methods used and the trainees' perceptions of the training. Phase 2 was to find out what external factors made a major contribution to the trainees' experiences and uptake of IT, the trainers' and trainees' attitudes and perceptions of the training and how it should be delivered. Phase 3 will collect more in-depth information about the trainees' change in attitude towards IT and training, whether they are continuing to use the same IT applications in their jobs, and how the uptake has affected the organization's training policies and procedures.

## 5. METHODOLOGY

This paper focuses on Phase 1, which used a survey methodology, complimented by individual interviews and observations. This was based on the approach used by Wynekoop (1992) who studied the implementation of computer-aided software engineering (CASE) tools in organizations combining qualitative and quantitative methods. The instruments for the survey included a 37-item *trainee* questionnaire to measure the trainee's perceived training needs, knowledge about IT and their perceptions of the training courses which they had attended. This same questionnaire was also administered to three trainees immediately after a training course on "Welcome to Word for Windows" to measure their immediate perceptions of this specific course and what they had learnt. A 26-item *trainer* questionnaire was used to assess how the training was structured, the organizational policies and procedures concerning the training, and the identified training needs of the employees. An interview with the Director of the Department of Information Technology Training, document collection and structured observations of one training session were used to gather more in-depth information about the training courses and the training experiences.

## 6. RESULTS OF PHASE 1

Selected results for Phase 1 are presented in the following sections.

### 6.1 Phase 1: Literature Review

Previous IT-BT studies were reviewed to provide the basis for the development of a conceptual framework using psychological attitude theories (Shifter & Ajzen, 1985), and organizational factors identified from the review. The literature revealed personal factors which had an impact on training effectiveness; for example, attitude towards IT, ease of use, and perceived behavioural control (Roberts & Henderson, 2000), and organizational factors such as situational constraints and managerial interventions of IT (Agarwal et al., 1996), see Section 6.3.

### 6.2 Factors identified from Phase 1

120 of 185 trainees (65%) and all eight trainers responded. Several different methods of training were used (traditional classroom, classroom assisted video with help from the trainer, workshops using computers,

individualized booth video training). 76% of the trainees perceived the technology to be easy to use and the courses to be useful. 66% preferred the IT-BT aspects of the training, and they had a positive attitude towards the training experience. However, for the majority of the trainees (68%) there was not enough time to ask the trainer all of their the questions, and insufficient IT-practice time. They found the manuals complex; some of the trainers lacked appropriate teaching skills. All 8 trainers had a favourable opinion of the training and, contrary to the trainees, perceived that the time spent on explanations and practice during the training were both adequate. The trainers' interview showed that they adjusted their teaching style to match the different abilities of the trainees.

Observations of the trainees during the hands-on session showed that the trainer and trainees interacted through question and answer episodes; the trainees also interacted and assisted one another. Post-questionnaire results showed that they felt that the course contributed to their ability to use IT and they enjoyed this type of learning. Management also perceived this training positively and felt that the organization needed this training. Factors resulting from the first phase included both personal factors (e.g., attitude, perceived behavioural control), and institutional factors (e.g., management's perspective, the trainers' attitude toward the training, organization of the training and delivery mode). The results showed that some institutional factors negatively affected the training experience, such as a lack of resource provisions, insufficient practice time during the training sessions, and the trainers' lack of appropriate teaching skills.

### **6.3 Conceptual model for evaluating IT-Based training**

The literature review and empirical evidence from Phase 1 show that the following factors need to be considered when measuring the effectiveness of IT-BT. These include personal factors, such as the attitudes of the trainees towards IT and training, their perceived locus of control of IT and training, and the influence of attitude on their change in practice and actual use of IT in the work-place. The institutional factors include the management's perspective of the training, the trainers' attitudes towards the training, organization of the training, the delivery mode and the training experience. The outcomes in the model include the trainees' changed attitude towards IT and training, their acquisition of new knowledge and skills and their improved work practices. The conceptual model was adapted from Schifter and Ajzen (1985) for use with IT (Figure 1). It shows the personal factors such as attitudes and subjective norms and how these relate to perceived behavioural control and performance. The combined model of the training

process including institutional and personal factors (Figure 2) is based on previous research, theories, and results of Phase 1.

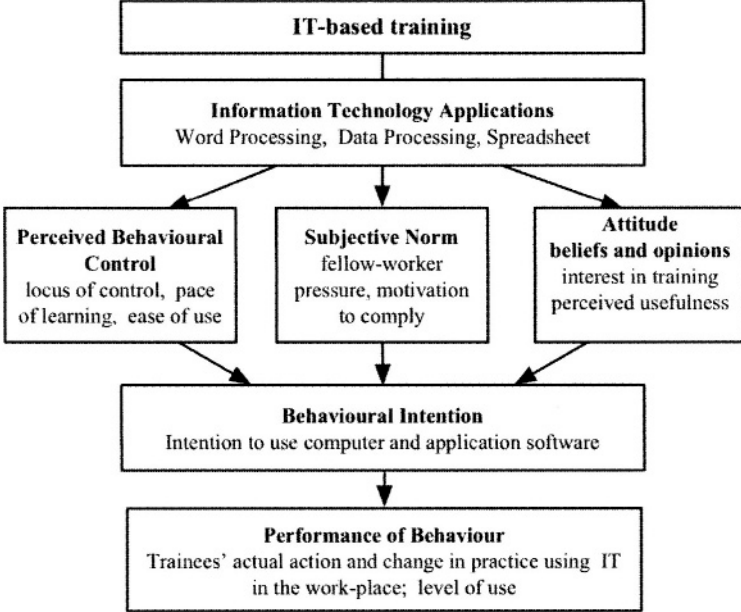

Figure 1: Conceptual Model of the personal factors relating to IT-based training and uptake.

## 7. CONCLUSIONS

Phase 1 results showed that the training did not always lead to the subsequent uptake of IT by all trainees in their work practices. There was often a mismatch between the trainers' and trainees' perceptions of how the training should be organised, and many trainees did not feel confident to use IT after the training. The results of Phase 1 also showed that we needed more detailed information about the trainees' attitudes, and the effects of the institutional factors on their integration of IT in their work. The conceptual model below shows that both personal and institutional factors must be considered when planning IT-BT programmes. This model is now being used in Phases 2 and 3 of our research and can be used by others designing and evaluating IT-BT. Phase 2 involves the same approach as Phase 1 but with a much larger sample (over 500).

Phase 3 involves further interviews, observation of working practices after the training, and an attitude test to validate the relative importance of the factors in the conceptual model and thereby the model itself.

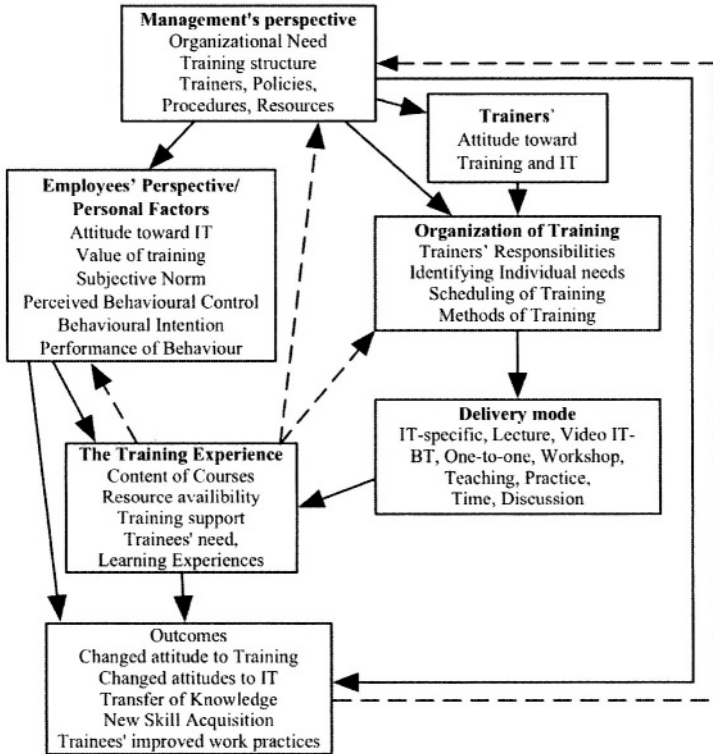

Figure 2. Combined Conceptual Model: Focus on Institutional and Personal Factors.

## REFERENCES

- Agarwal, R., Prasad, J., & Zanino, M. C. (1996). Training experiences and usage intentions: A field study of a graphical user interface. *International Journal of Human-Computer Studies*, 45, 215-241.
- Arnold, J., Cooper, C. L., & Robertson, I. T. (1995). *Work Psychology: Understanding Human Behaviour in the Workplace*. (p. 309). London: Pitman Publishing.
- Chou, H. W. (2001). Influences of cognitive style and training method on training effectiveness. *Computers and Education*, 37, 11-25.
- Goldstein, I. L., & Ford, J. K. (2002). *Training in Organizations: Needs Assessment, Development and Evaluation*, (4<sup>th</sup> ed.). California: Thomas Learning, Inc.



- Harrison, D. A., Mykytyn, P. P., & Riemenschneider, C. K. (1997). Executive Decisions about Adoption of Information Technology in Small Business: Theory and Empirical Tests. *Information Systems Research*, 8(2), 171-195.
- Kettanurak, V. N., Ramamurthy, K., & Haseman, W. D. (2001). User attitude as a mediator of learning performance improvement in an interactive multimedia environment: An empirical investigation of the degree of interactivity and learning styles. *International Journal of Human-Computer Studies*, 54, 541-583.
- Leidner, D. E., & Jarvenpaa, S. L. (1995). The use of information technology to enhance management school education: A theoretical view. *MIS Quarterly*, 19(3), 265-291.
- Nordenbo, S.V. (1990). How do Computer Novices Perceive Information Technology? A Qualitative Study Based on a New Methodology. *Scandinavian Journal of Educational Research*, 34(1), 43-73.
- Rae, L. (1995). *Techniques of Training*. (3<sup>rd</sup> ed.). Hampshire: Gower Publishing.
- Roberts, P., & Henderson, R. (2000). Information Technology acceptance in a sample of Government Employees: A Test of the Technology Acceptance Model. *Interacting with Computers*, 12, 427-443.
- Rossett, A., & Gautier-Downes, J. (1991). *A Handbook of Job Aids*. California: Pfeiffer.
- Salas, E., & Cannon-Bowers, J. A. (2001). The Science of Training: A Decade of Progress. *Annual Review of Psychology*, 52(1), 471-499.
- Schifter, D. B., & Ajzen, I. (1985). Intention, perceived control, and weight loss: An application of the Theory of Planned Behavior. *Journal of Personality and Social Psychology*, 49, 843-851.
- Torkzadeh, G., & Van Dyke, T. P. (2002). Effects of Training on Internet Self-efficacy and Computer User Attitudes. *Computers in Human Behaviour*, 18(5), 479-604.
- Venkatesh, V., & Speier, C. (2000). Creating an Effective Training Environment for Enhancing Telework. *International Journal of Human-Computer Studies*, 52, 991-1005.
- Wishart, J., & Blease, D. (1999). Theories underlying perceived changes in teaching and learning after installing a computer network in a secondary school. *British Journal of Educational Technology*, 30(1), 25-41.
- Wynekoop, J. L. (1992). Strategies for Implementation Research: Combining Research Methods. In J. DeGross et al. (Eds.), *Proceedings of the 13<sup>th</sup> Annual International Conference on Information Systems*, Dallas, Texas, December, pp. 185-193.

## BIBLIOGRAPHY

Margaret Cox has research interests in the use of ICT in education and their effects on teaching and learning, and motivation; teacher training in the uses of ICT; development and evaluation of computer-based modelling and simulations; the uptake of ICT in education; use of ICT in science education and in Dental undergraduate programmes. Lena Wilkinson is an Adjunct Faculty member at the School of Business and Technology, Webster University. Her research focuses on IT-CBT and organisational and employee attitudes and behaviour towards the uses of ICT for training, professional development and changes in work practices.

# FOCUS GROUP REPORT: MOBILITY AND EDUCATION

**Chair:** Raymond Morel, CPTIC, raymond.morel@techfaunige.ch

**Rapporteur:** Arthur Tatnall

**Participants:** Harri Ketamo (Finland), Timo Lainema (Finland), Jari Koivisto (Finland), Barbara Tatnall (Australia)

**Key words:** Mobile learning, mobile platforms, flexible learning, hand-held computers.

## 1. INTRODUCTION

The digitisation and convergence of media, communications, and Information Technology, and the advent of wireless computing, offers new possibilities for teaching and learning in all forms of education. In our initial discussions we agreed that although mobile technologies were a significant driving factor, the human issues concerned with the use of these technologies were a much more important consideration. Situations relating to mobility in education can be grouped into three categories:

1. People changing location but able to use ICT to gain access to the same information and facilities from the new location.
2. People equipped with mobile technology they can take with them, and so access information and facilities from other remote locations.
3. Mobile presence; the ability for a person to *appear* to be available at some remote location while really remaining at a base location.

Educators must remain interested in the development of mobile technologies, and also engage with the industry, because it may develop pedagogically inappropriate innovations. Constraints on using mobile technologies include costs, privacy, the need to ensure ethical use, and copyright laws.

## **2. USING MOBILITY IN EDUCATION**

Pedagogy, not technology, should drive the development of mobile technologies in Education. The group did not believe that mobile computing would, or could, replace traditional forms of learning in the future. However, it did see great possibilities for supplementing traditional forms and adding new educational possibilities. What other possibilities for these technologies exist in formal education or informal learning is not clear; issues of education versus training, teaching versus learning, studying versus learning and facts versus concepts/values need consideration. Enhanced learning could be realised in initial education, life long learning and corporate training, but differences between training (skills development) and education (meta skills) should be borne in mind. Important questions are: how might mobility help learning? what possibilities can mobility bring to education? Are there educational needs waiting to be fulfilled by mobile technologies, or will these needs be invented—and by whom?

The group sees mobile technologies as not only offering possibilities to do the same things in better ways, but also to do new things. It is characteristic of educational innovation that you cannot predict what will and will not work until you try things out and reflect on the pedagogy and practicalities. Students themselves might suggest these new possibilities when they gain familiarity with mobile systems. Issues of remote versus local teaching, synchronous versus asynchronous communication and working with individuals or groups are relevant here.

## **3. EXAMPLES OF MOBILITY IN EDUCATION**

From a central location in northern Finland, a music teacher gives regular classes to students in a small primary school 85km away using ISDN video-conferencing. The teacher plays the piano and acts as conductor of the school orchestra. The 0.5-second delay between voice and picture causes some difficulty for the teacher, but it does not seem to lessen the pleasure of those playing in the orchestra. Another example used a 'web cam' in an art gallery. Students could use Bluetooth technology to set up short-term, ad hoc teams of anyone interested in a particular exhibit. Other examples include: access to 'real' situations, taking pictures of animals in a forest, expanding and updating knowledge databases, sharing actions between home and school, extending the capacity to be critical, increasing cultural understanding, forming virtual teams and creating personal portfolios.

#### **4. RECOMMENDATIONS AND ACTIONS**

There is more to mobile learning than technology alone. It is recommended that consideration be given to all actors and to social, cultural and pedagogical impacts. At present there is no clear vision of how mobile computing could benefit learning, but this was considered preferable to having an educationally inappropriate vision. Concern was expressed of a need to offer expertise and services to manufacturers in the hope that they may work with us on projects. It is recommended that pilot programs, research and trials be encouraged and linked with curriculum development and teacher training. The group believes that mobile learning needs further investigation, as its potential educational impact is considerable. Means by which this might be achieved were identified, including: seeking links to other IFIP Working Groups and other Technical Committees to facilitate research, actively encouraging them all to focus on this topic from their perspective, setting up a reporting mechanism for developments, setting up a working conference on m-learning, setting up a professional group on m-learning at WCCE'05, asking TC3 to set up a Task Force on mobile learning.

#### **5. CONCLUSION**

Technological developments in ubiquitous and mobile computing offer possibilities to all levels of education and, due to their non-reliance on traditional communications infrastructure, they offer emerging countries an opportunity to jump ahead. Exactly how these technologies should best be used in education, however, is not completely clear at this time. It is important that further work be done in evaluating potential uses of mobile computing in education. This focus group recommends that TC3 set up a Task Force on mobile learning to conduct these investigations.

#### **REFERENCES**

- Uther, Maria (2002). *Mobile Internet Usability: What Can Mobile Learning Learn from the Past?* IEEE International Workshop on Wireless and Mobile Technologies in Education August, Växjö, Sweden.



## **SECTION 2: PROGRAMS AND CURRICULA**



# **‘ANYBODY OUT THERE A REAL EXPERT?’**

## *Transition into the Online Learning Environment by First Year University Students*

Meeri Hellstén

*Macquarie University, Australia*

**Abstract:** This paper reports on an evaluation of online learning in a large Australian undergraduate first year university subject. A central focus is the effectiveness web based learning and its implications for facilitating transition pathways into a new learning environment by new university students. The research is situated within a framework of action research and curriculum evaluation by exploring the different uses of a subject web site. Student postings on the web site bulletin board were evaluated. The interpretive content analysis indicates that the online mode of delivery is most beneficial in the distance education mode acting as a socialization and inter-relational device.

**Keywords:** higher education, teacher education, curriculum development, pedagogy, research

## **1. INTRODUCTION**

Web-based learning is fast becoming an everyday concept among beginning students in Australian Higher Education. Most university subjects are now offered in distance mode utilizing online technology. This has provided students with added flexibility, enabling learning to be undertaken anytime of the day and from anywhere in the World.

The are wide-ranging applications for a successful online learning system. For example, online technology is useful for facilitating transition into Higher Education by school leavers, as well as by professionals returning to university study. In such settings, online technology acts as a resource in providing procedural knowledge (Biggs, 2001, p. 48) about the institution and the course structure over and above the actual subject content.



Academic reading and writing is one such supplementary area. The procedural knowledge required to compose a high standard university essay, for example, is not explicitly taught as part of subject content. Thus, an interactive online facility addressing academic and information literacy can equip beginning students with a wealth of necessary procedural knowledge and generic skills that are integral to a successful university career.

## **2. FIRST YEAR ORIENTATION**

The success of online learning is based on the assumption of some prior information technology (IT) skills. While many students today enter university with at least basic computer skills, it poses potential problems for those students who lack them. How accessible is a web resource to students who have little previous experience with computers, let alone the Internet? It raises important issues about the effectiveness of online learning as a resource in the process of transition into university study. In the subject evaluated for this research, students are provided with web-based resources to support their first year orientation. The subject homepage, which is often the first website students encounter as part of their online learning career, lists information with links to a network of student information and resources within and outside the institution and the World Wide Web.

Previous subject evaluations give the impression that students make active use of the information provided on this site. What has not been formally investigated in this context, however, is the depth and breadth of site uses that may provide objectives for developing and implementing specific areas of the subject's online curriculum. This paper reports on the experiences of first year university students enrolled in a large core subject with an obligatory online study component. The aims of this research are:

1. A partial focus is on evaluating students' uses of the online teaching mode for subject curriculum development and implementation by the convener.
2. To allow the evaluation to inform future pedagogical practices in and through the e-learning environment.
3. To explore implications for enhancing the first year transition experiences through online technologies.

The following section describes the methodological framework of the curriculum evaluation research.

### **3. THE RESEARCH CONTEXT**

The theoretical conceptualisation of this research is located within the philosophical perspective of knowledge as constitutive of, and constructed by, everyday practices and social actions (e.g. Sacks, 1992). The premise of this theory for learning is that it is situated and cannot be separated from the context within which it is constructed (Lave & Wenger, 1993). Therefore, an exploration of everyday online interactions—such as that provided by a website bulletin/discussion board in a given university subject—yields insights into the types of knowledge and meanings that are constructed within that environment. It is the premise of this research that these different types of knowledge constitute the overall student experiences of online learning.

The research data sample consists of 288 student postings to a core subject online bulletin board. The overall student population in the subject concerned is in the low six hundreds of a one semester introductory first year subject in Education. The subject has a compulsory online assessment component. Students are advised to access the online mode as soon as they have gained entry into the subject after enrolment. Students are encouraged to use the bulletin board for general communication purposes. They are informed about ethical conduct regarding politeness and so called ‘netiquette’ issues.

The study has received clearance from the University’s Ethical Research office. The students were aware that their written messages might become part of an action research study. In order to protect students’ identities, the postings were removed from the bulletin board by a research assistant who coded and deleted students’ names. The final data sample contained only coded identifiers attached to each posting, for increasing readability and interpretation of the sequencing of communication.

### **4. RESULTS**

An interpretive content analysis (Freebody, Ludwig, Gunn, 1995) was conducted on the selected data sample. It revealed five broad themes of talk into which the student text samples could be thematically grouped. The unedited data are listed in Table 1 below. It is now commonly known that communication in cyberspace has constructed a function that is fast disappearing in real life, namely that of allowing for closeness and directness between communicators (Thomsen, Straubhaar & Bolyard, 1998).

Table 1. Number of postings according to textual themes and corresponding content<sup>1</sup>

Theme	content	content	content
Initial introductory logon n = 68	Seeking contact n=37	Orientation n=46	Disclosing previous experiences n=30
Seeking help n=24	Audio n=4	Software related n=11	Other n=9
Procedural knowledge n=60	Assignments and exam n=36	Online component n=21	Research related n=9
Evaluative n=14	Affective n=6	Constructive feedback n=7	Other n=2

<sup>1</sup> Numbers are not exclusive

It was therefore not surprising to find that the majority of messages on the bulletin board were posted for the purpose of establishing personal contact. For example, finding a companion to study with was a particularly frequent topic among distance education students. A combination of themes introducing oneself with a short biography, and calls for a study partner, were also prevalent among the first postings. Typical messages in this category read as follows:

“Hi I’m a mature student too. Don’t worry (name) find yourself a study buddy it helps enormously and you don’t feel alone.”

“K here again. A study buddy sounds like a good idea. Anyone in (Suburb) area interested in study buddying with me, just let me know.”

The sense of distance and isolation created by cyberspace (Gibbs & Krause, 2000) generates a need to form unanimous communities. Themes combining an introduction with suggestions for information about the subject administration and structure appeared among the bulletin postings within the first two weeks of term. Since the bulletin board is primarily meant as a student facility with little academic staff input, such requests for help were ordinarily answered by fellow students. Thus, students realized the supportive function of the site relatively swiftly.

In some cases, the online mode was used for seeking help with online technology. Procedural knowledge is a central concern, for example questions about downloading free software from the Internet for accessing online subject audio-visual data, such as audio lectures and lecture notes. Students had some trouble with hands-on tasks such as navigating the internet, finding and saving web browser ‘plugins’, and downloading other software products. An exchange of instructions was made available by fellow students, for example:

“Click on the “lecture theatre” icon to view links to the online audio version of lectures and accompanying slides...” or “Try this, right click on the link, choose folder and file name, click. Worked for me.”

Many postings (n=60) concerned procedural knowledge. Thirty-six of these involved assessment tasks. Issues ranged from how to conduct research with human subjects, to interviewing techniques and finding information for report writing, using citations and other issues related to academic literacy. Students also used the bulletin board to acquire procedural knowledge about the institution and different discipline areas. It acted as a resource for ‘finding your way around the university’. Eleven postings addressed the online component of compulsory subject assessment. Many questions seemed to arise from failing to read and follow instructions, typing errors (such as ignoring case sensitivity when it is required etc.) and poor computer skills (such as right/left click on a mouse). For example:

“I’ve talked to a few people who say they can’t get the online version of the lectures....I’ve tried as well, unsuccessfully.. I know you can get the tapes from the library, but it would be nice to be able to get them to work, wouldn’t it? Anybody out there a real expert?”

The latter case is of most interest to the evaluation of online subject delivery. Students in this subject are offered extensive assistance in basic to advanced computer technology skills. Scaffolded instructions about how to download ‘plugin’ software from the Internet, for example, can be found on many websites. Further, instructions are made available in printed format in this instance and handed out to students. Students also have ICT training available to them through the University library. With the provision of training the assumption of prior knowledge is, in this instance, warranted.

However, these postings infer that students have failed to a) take advantage of the IT learning opportunities available to them at the start of term or b) have not retained and/or applied the information provided in training sessions. What seems puzzling is the lack of transfer between instructions received and application of the basic IT skills.

## **4.1 Further research**

Further research is need to determine the motivating factors behind such failures. Is there a belief among students that IT skills are somewhat auxiliary, as opposed to obligatory, for successfully completing the subject? What are the institutional, behavioural and/or motivational variables preventing students from acquiring procedural knowledge in IT skills? The final category has the theme of evaluation of the online learning experience.

In the last week of term, students were asked to provide feedback on the bulletin board about their learning experiences. The postings in this theme have two features, 'affective remarks' and 'constructive feedback'. The nature of computer-mediated communication (CMC) has been documented as enabling for more emotive expressions than communication in 'real life' (Cerulo, 1997). Emotive commentary appeared in all categories of text samples. Recall from above the terms 'felt a bit lost', 'felt overwhelmed', 'pretty scared', 'petrified'. Other expressive comments were of a more spontaneous nature such as:

"...just wanted to say that this web site rocks. I have found so much info for my study...thank you to (name) for supplying this web site"

Constructive feedback about the web site was expressed in more formal context, as in the following:

"...this website has been very helpful and informative, thank you to whoever designed and helped out in general with this subject."

It seems that cyberspace provided an easier mode for expressing one's feelings about a learning experience generally, and about online learning in particular. On the other hand, there were no negative evaluative expressions on the online content. Negative feedback addressed other aspects of the subject content, such as the textbook and assessment. The data represented in Table 1 suggests that the student experience of online learning is a positive one despite an evident lack of initial procedural knowledge in IT skills. The bulletin board text samples indicate that regardless of some technical difficulties students made immediate and active use of the online mode in the first weeks of their university candidature. The function for narrowing communicative distance was also realized by the users of the discussion board. Effortless comments about personal and biographical information were posted with the apparent aim of establishing closer relationships with other users of the site.

## **5. DISCUSSION**

The immediate ease with which students adopted the online learning mode indicates that it provides a means for aiding transition into university study. The analyses of discussion postings strongly suggest that students readily accessed the web based learning mode and used this as an orientation resource. The web bulletin board served as a device for constructing

cohesion within the student population. This allowed students to draw upon each other for help.

A number of implications stem from these findings. First, there is sufficient evidence here for expanding the development of online learning modes for first year student transition purposes. The system can act as a spring board for finding general information about the institution and its structures as well as an understanding of some disciplinary cultural practices, such as genres for assignment writing. More importantly, with increasing globalization of university programs, the online learning mode fills an important function for distance education.

Students logging on to the website discussion board from remote locations can engage in meaningful interaction with fellow students sharing similar experiences. Interaction with more experienced fellow students is reassuring for first year students in transition into a university career (Austin, Covalea, Weal, 2002; McInnis, 2001). As indicated by the few examples above of student interactive exchanges, the bulletin board constructs a pedagogical relationship of mediating mentoring between experienced students and their inexperienced student counterparts.

Further implications concern the development of subject curriculum to incorporate online materials designed specifically for the transition objectives. One example currently in place is the Writing Gateway Project university web site focusing on academic literacy. On this site students are able to complete workshops, draft assignments and browse previous course work samples in a given learning discipline.

## **6. CONCLUSION**

Clearly, continued evaluation of the pedagogical functions of web sites are needed, especially in subjects with large student numbers such as the current one. The pedagogical applicability of the contents of web sites in some cases need to be revised to suit the needs of the immediate student group. Needs analyses are beneficial here and can be conducted by simple means of discussion boards. The benefit of continued subject revision for enhanced teaching and learning opportunities are then warranted by providing a context for situated learning opportunities within and through online practices.

One consideration of the data corpus of this study is the possibility that the text samples may have been posted by students particularly well versed in CMC. The contents acknowledging application failures and asking for help that were so prevalent among the first discussion postings however, indicates the contrary. It provides a firm basis for assuming that at least the

majority of postings in our data sample derived from students with a range of computer skills. Clearly, future research exploring the student perspectives of online learning and its impact on the first year transition path is needed as are studies expanded to a wider student sample across disciplinary boundaries. In sum, the current findings support the positive implications of online teaching and learning for constructing pedagogical pathways through the first year study experience. The outcomes suggest that a variety of mentor and transition programs may benefit from a combination of face to face and online curriculum offerings.

## REFERENCES

- Austin, J., Covalea, L., & Weal, S. (2002). Going the Extra Mile, Lilydale's Mentor Program. Proceedings of the 16<sup>th</sup> AEIC, IDP Education Australia, Hobart, Tasmania, 1-4 Oct.
- Biggs, J. (2001). Teaching for Quality Learning at University. What the Student does. Buckingham: Open University Press.
- Cerulo, K. A. (1997). Refraining Social Concepts for a Brave New (Virtual) World. *Sociological Inquiry* 67 (1), 48-58.
- Gibbs, D., & Krause, K. (Eds.). (2000). *Cyberlines. Languages and Cultures of the Internet*. Albert Park: James Nicholas Publishers.
- Freebody, P., Ludwig, C., Gunn, S. Everyday Literacy practices in and out of schools in low socio-economic urban communities. Vol. 1. Report presented to the Commonwealth Department of Employment, Education and Training and the Curriculum Corporation. Commonwealth of Australia. Pp. 89-94.
- Lave, J., & Wenger, E. (1993). *Situated Learning: Legitimate and peripheral participation*. Cambridge MA: Cambridge University Press.
- McInnis, C. (2001). Researching the First Year Experience: where to from here? *Higher Education Research and Development*, 20(2).
- Sacks, H. (1992). *Lectures on Conversation*, Vol. 1. G. Jefferson (Ed.) Oxford: Blackwell.
- Thomsen, S. R., Straubhaar, J. D., & Bolyard, D. M. (2002). Ethnomethodology and the Study of Online Communities: Exploring the Cyber Streets. Proceedings of the IRISS International Conference, Bristol, UK, 25-27 March. Retrieved 18.04.2002 from <http://sosig.esrg.bris.ac.uk/iriss/papers/paper32.htm>.

## BIOGRAPHY

Meeri Hellstén has lectured in Teacher Education since 1993. Some of her particular research interests are in the areas of effective teaching and learning, transition experiences in Higher Education, cross-cultural and international education and e-learning. She is previously published by Multilingual Matters and currently by Routledge.

## **ACKNOWLEDGEMENTS**

The author would like to thank Dominique Beck and Dan O'Brien for their assistance.





# WHAT STUDENTS EXPECT FROM E-MODERATION

Udo Hinze and Gerold Blakowski

*University of Applied Sciences Stralsund, Germany*

**Abstract:** Overall, students have evaluated the tutoring processes at the Virtuelle Fachhochschule—Virtual University of Applied Sciences—positively. The interviewees, however, gave very different opinions, which varied with the individual needs of the student. The fields in which our tutoring was offered (including social, professional, technical and organisational aspects) and other crucial factors (i.e. response times of tutors) received diverse ratings. The variety of these responses was summed up in proposals for improvement, which, among others, suggested more flexible communication, tutoring and doctrine. Furthermore, a stronger integration of a conventional academic doctrine was suggested.

**Key words:** Computer Assisted Instruction, Tutoring, Virtual learning organization

## 1. INTRODUCTION

E-Moderation is a key element of eLearning programs. It is not only interesting for theoretical discussions, but more and more it is considered to be a crucial factor in underpinning the realisation of e-Learning goals within large projects—such as many e-Learning projects at the Virtuelle Fachhochschule (VFH).

A successful implementation of e-Moderation or e-Tutoring concepts requires, as essential elements, both knowledge of the range of students' needs, and to take their proposals for course improvement into consideration. Questions regarding central aspects such as quicker response times, an increased level of active tutoring and a general balancing of the tutoring are critical factors for the success of the course and overall student satisfaction.

## 2. STUDYING AT THE VFH

Several Masters and Bachelors degree courses in Computer Science and Economic Engineering have been developed within the German pilot project ‘Virtual University of Applied Sciences for Technology, Computer Sciences and Business Administration’ ([www.vfh.de](http://www.vfh.de)). These courses are mainly taught online. Some 20% of them use a blended learning approach—which combines online and face-to-face approaches—via the Blackboard Learning System™. Twelve Universities of Applied Sciences and two university colleges, as well as commercial partners, are involved in the project. After several pilot phases, a Bachelor degree course in Computer Science started in autumn of 2001 with 166 students. This course is carried out by some of the co-operating project partners on the basis of networking arrangements between several German Universities of Applied Sciences. The students themselves are enrolled in one of these participating Universities of Applied Sciences.

## 3. TUTORING AT THE VFH

Students are supervised by student and scientific assistant tutors, as well as by academic staff lecturers from the University of Applied Sciences in which the students are enrolled. Besides being available during office hours for appointments, the tutors implement the online-tutoring process. The main part of the tutoring process takes place in the ‘learning room’ of the *Blackboard Learning System*™. There are two approaches to online tutoring (e-Moderation). In the first approach, student and scientific assistant tutors use Blackboard and the Instant Messaging System *ICQ* ([www.icq.com](http://www.icq.com)) to communicate with students. In the second approach academic staff lecturers would use Blackboard and the audio conference tool *Netucate* ([www.netucate.com](http://www.netucate.com)) for audio-chats and application sharing. A weekly two-hour audio conference was offered to students of each module.

## 4. EVALUATION

Different evaluation tools were used to evaluate the tutoring process. To determine the students’ opinions, questionnaires were used in conjunction with focus-group interviews. After evaluating the 62 returned questionnaires, telephone interviews were also conducted with the interviewees. In addition to this, the students’ messages in 23 discussion forums were analysed. The forums were initially analysed from a quantitative point of view and were

then reviewed based on the *Qualitative Content Analysis* according to Mayring (2000). Finally, the findings were listed, coded, and assigned to inductively defined categories.

## **4.1 Weighting the tutoring**

Tutoring, as such, is increasingly considered the crucial factor in the realisation of eLearning programs. However, even when learning content is adapted and presented in an excellent fashion with the help of multi-media applications, and delivered in an online interactive environment, it cannot guarantee the success of an e-Learning course. Teaching and learning are always brought across in a social context. In other words, teaching always consists of two components: an informational and a communicative component (Kerres 1998). Therefore, for the learning process to be effective, it is vital to receive personal feedback, which goes beyond computer generated spell-checks or the mere return of information about a learning deficit.

Students also share this point of view. More than 85% of the students stated that ‘the tutoring is just as important as the course design itself’. When asked to complete the phrase ‘Learning at the *VFH* without appropriate tutoring is...?’, students responded with answers such as ‘... it is not much different from buying yourself a book and learning...’, or ‘... like not seeing the light at the end of the tunnel...’, or even ‘impossible to do’.

## **4.2 Assessment of tutoring**

Overall, the tutors’ competence at the *VFH* was well rated by the students. Yet certain distinctions need to be made. Differences existed not only between the assessment of single tutoring aspects and respective courses, but also between the tutoring approaches and statements regarding central aspects such as response times.

### **4.2.1 Specific course characteristics**

While 73% of the interviewees noted course-specific differences, there was a wide spectrum of answers to the question of the nature of those differences. ‘A different personal commitment’ on the tutors’ part was demanded with the positive qualification that this commitment was in any case, ‘not bad anywhere’. Another finding revealed concerns about varying response times to course questions. The lack of a synchronous communication via chat-rooms was also pointed out.

#### 4.2.2 Tutoring aspects

The very different levels of student needs played an integral role in the different evaluation of the tutoring process. This becomes clear by looking at central aspects—like the request for quicker response from tutors. 33% of the interviewees agreed with the statement ‘I would have liked a quicker response from the tutors’, whereas 20% were indecisive and 47% rejected it. However, according to the quantitative communication analysis of the discussion forums, response times by tutors were appropriate. The forums were mainly designed to facilitate an exchange between the students, so that a large part of the communication was self-regulated. The tutors only played a supporting role. Hence, response times in the forum were clearly longer than responses based on email communication. Questions which arose and that were directed at tutors were answered relatively quickly (on average within 45 hours). This number is not too significant, as answers by the interviewees varied immensely. The following graph shows how many responses were provided in 24 and/or 48 hours, respectively.

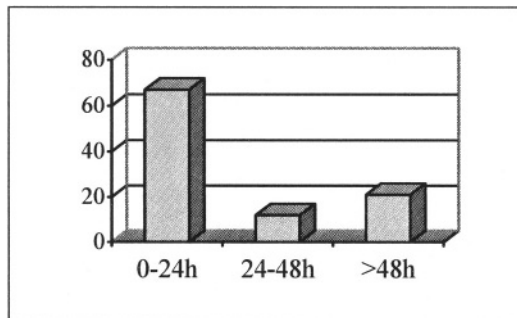

Figure 1. Response times of the tutors in the discussion forum

Answers as differentiated as those to response time satisfaction (above) were also found in the reactions to the following statement: ‘... the tutoring process should not only consist of answers to questions, but tutors should also be more active and thought-provoking (i.e. more cross-checks)’. Here, 47% of the interviewees agreed, 13% were indecisive and 40% were of a contrary opinion. The widespread demand for active tutoring is didactically and methodically understandable. However, it is not always identical with the students’ interests and expectations. The differences were also manifested in the general views about the course of studies. Besides a certain degree of flexibility, many students also valued the fact, that online-learning

is embedded into a social context. For other students flexibility alone is vital and they believed that, as such, there is no need for social communication.

### 4.2.3 Areas of competence

Similar differences were found in the assessment of the individual areas of tutoring competence. Moderation was defined as ‘chairing’ a meeting or a discussion. In the electronic world, however, it combines different roles: to hold meetings, to encourage students, to provide information, to raise questions, to summarise etc. (cf. Salmon 2000). For this reason, it is not surprising that an abundance of different classifications for tutoring areas can be found in the literature. A common pattern is found in Berge & Collins (2000), who define the roles of tutors in e-learning as filters, fire-fighters, facilitators, editors, managers, discussion leaders, content managers, assistants, and marketers. When dividing their roles into the different areas of activity, we can distinguish between the following (i.e. Bonk, Kirkley, Hara & Dennen, 2001):

- Technical aspects (Do students have the required basic knowledge? Does their equipment work? Do their passwords work?);
- Managerial aspects (Do students understand the assignment and course structure?);
- Pedagogical aspects (How are students interacting, drawing up conclusions, debating, thinking?);
- Social aspects (What is the general tone? Is there a human side to the course? Is joking allowed?).

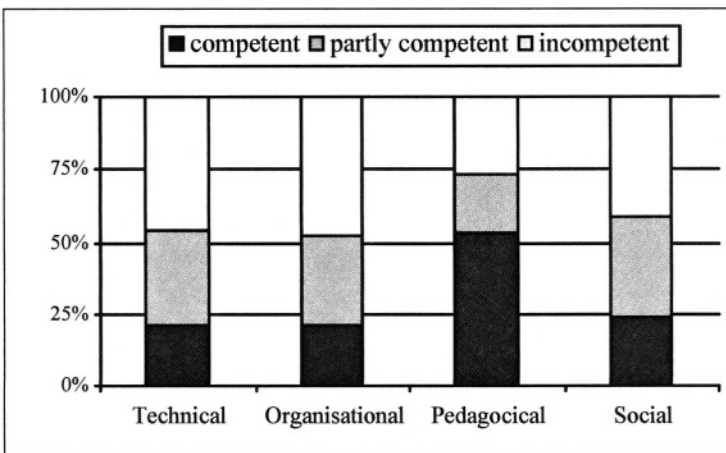

Figure 2. Weighting of the tutoring

From an organisational point of view, the tutors' competence was remarkably well appraised, probably because potential problems had largely been eliminated in previous pilot phases. The fact that social competence was appraised more negatively in relation to organisational competence can possibly be explained in terms of the situation being a new one for both students and tutors. Achieving the required excellence with computer-aided communication tools is primarily time-dependent. Some tutors had the required virtual socialisation skills already, while others had to acquire them.

Professional competence was generally appraised positively. Some aspects of the didactic design (i.e. outstanding responses and solutions to the practice tasks) were evaluated negatively. Frustration with deficiencies in the courses might have affected the generally positive assessment of the course in regard to the tutors' perceived pedagogic competence. We came across similar findings in the area of technology. Here, a hanging or crashed server was mentioned as the main problem. This fact overshadowed the otherwise very positive evaluation of the technical competence of the tutors.

### **4.3 Tutoring Concepts**

The differences between the concepts of tutoring or e-Moderation were much less significant than we had initially assumed. A survey regarding general satisfaction with the course suggested similar results, despite differences in the concepts (cf. Arnold, Kilian & Thillozen 2002). Moreover, the tutoring concepts were largely evaluated similarly in all four areas of competence. Course-specific differences were larger than those between the tutoring models. It became evident that the decisive factor was not the tutoring concept as such, but, rather, the personal commitment of the tutors.

### **4.4 Proposals for Improvement**

Students' proposals for improvement varied as much as the evaluation of the tutoring itself. Some proposals suggested a higher degree of flexibility, quicker response, and increased tutor availability. A method of flexible and spontaneous communication has already been established through the tutoring process, especially by integrating an Instant Messaging System (ICQ). Other suggestions highlighted the need for tutors to be available after 5pm, and even on weekends, via phone. While the central advantage of e-Learning is its high flexibility, implementing such proposals for a more responsive 24-7 tutoring program are difficult from an organisational point of view, and not always possible because of their high cost implications.

The demand for better collaboration between module authors and tutors is another key issue. Inconsistencies and problems occasionally arose

because authors also developed parts of the tutoring concept. At the beginning of a course, the learning material and targets are not necessarily well known to all tutors. Moreover, in this starting phase, tutors need to be available at short notice for inquiries regarding the course material. Faults in the course material result in frustration on the part of the student. Hence, good quality material is of central importance for an improved level of tutoring. Demands from module authors for more participation in the module, i.e. personal input in discussion forums, start-up moderation, taking on tasks, discussion stimulation and feedback distribution, and for 'tutors with more background knowledge' have to be considered.

Students also addressed the use of different communication tools. Within this context, it was suggested to move the focus of attention: to hold 'regular chats (with a limited number of participants) once per week in which special questions about the respective fields can be discussed'. Altogether, both students and tutors used the chat function in *Blackboard* comparatively rarely. Part of the students also requested the availability of tutors by phone. The phone as a communication tool played an essential role within the learning group altogether. In general, the need for spontaneous and direct synchronous communication became evident.

Another central aspect concerned the request for more personal contact to the tutors. Many students emphasised explicitly that 'personal contact' and 'personal conversation' with the tutors are positive moments in the tutoring process. In the survey, one student explicitly pointed out that lunch with professors, tutors and students during the course 'is especially important as a social component'. The demand for replenishing and/or varying the doctrine goes hand in hand with this. The demand for a stronger integration in the course of studies with tutors was expressed relatively often. The general assumption that students would primarily prefer the flexibility and the anonymity of the online-learning could not be confirmed. On the contrary, 'the possibility of a partial integration into the 'normal' course of studies of the University of Applied Sciences (i.e. participating in practical exercises, etc.)' was directly addressed.

## **5. SUMMARY**

Above all, the evaluation of the tutoring or e-Moderation at the *VFH* reveals a broad variety of responses due to the different needs of students. Questions about central issues, such as faster responses or more active tutoring, produced diverse responses. The different student needs became evident in the proposals for improvement. Nevertheless, tendencies may be



inferred. First, better communication between tutors and course authors is essential. There is definite room for improvement.

Another aspect concerned the students' request for more flexibility in tutoring. The requested '24-7' tutoring is neither necessary nor feasible, but meeting requests for more personal tutoring is feasible. On one hand, the direct and individual online-tutoring by means of telephone and chat has to be increased. On the other hand, personal contact with tutors was requested for the single stages of the course. Although the *VFH* already practises online-learning as 'Blended Learning' it would be worthwhile considering whether and how one could reshape the *VFH* towards a greater incorporation of blended-learning' concepts.

## REFERENCES

- Arnold, P., Kilian, L., & Thilloßen, A. (2002). So lonely? – Online-Betreuung als kritische Erfolgsbedingung beim telematischen Studieren. Ergebnisse einer Befragung von Studierenden und Mentoren in der Virtuellen Fachhochschule für Technik, Informatik und Wirtschaft (VFH). In G. Bachmann, O. Haefeli & M. Kindt (Eds.), *Campus 2002: Die virtuelle Hochschule in der Konsolidierungsphase*. Münster: Waxmann.
- Berge, Z. L., & Collins, M.P. (2000). Perceptions of e-moderators about their roles and functions in moderating electronic mailing lists. *Distance Education: An International Journal*, 21(1), 81-100.
- Bonk, C. J., Kirkley, J. R., Hara, N., & Dennen, N. (2001). Finding the instructor in post secondary online learning: Pedagogical, social, managerial, and technological locations. In J. Stephenson (Ed.), *Teaching and learning online: New pedagogies for new technologies* (pp. 76-97). London: Kogan.
- Kerres, M. (1998). *Multimediale und telemediale Lernumgebungen*. München: Oldenburg.
- Mayring, P. (2000). Qualitative Inhaltsanalyse. *Forum Qualitative Sozialforschung*, 1(2). Retrieved from <http://www.qualitative-research.net/fqs> on 20.05.2002.
- Salmon, G. (2000): *E-Moderating: the key to teaching and learning online*. London: Kogan.

## BIOGRAPHY

Udo Hinze and Gerold Blakowski's fields of research include the conceptual design and realisation of ICT-based learning with a focus on computer aided learning. Recent research and development projects have explored a wide range of tutoring aspects of ICT-based learning.

# **A MODEL FOR PLANNING, IMPLEMENTING AND EVALUATING CLIENT-CENTERED IT EDUCATION**

*The Third Task of the University Calls*

Ilkka Kamaja and Juha Lindfors

*Department Research Methodology, University of Lapland*

**Abstract:** The Department of Research Methodology at the University of Lapland is developing a model for the planning, implementation and evaluation of education in the field of Information Technology (IT). The model draws on the concept of client-centeredness, and makes use of regional cooperation in order to carry out the universities' third task. The principal method used in the research is a constructive approach. The model is being developed, and its usability evaluated, in the context of two extensive degree programs at the Department of Research Methodology.

**Key words:** educational planning, information technology, client-centeredness

## **1. INTRODUCTION**

The University of Lapland, the northernmost such institution in the European Union, is located in the city of Rovaniemi, an international, growing centre of business, administration and education. The University is one of a number of educational institutions in the area. Although it is a comparatively small (3500 students) and young university (founded in 1979), it has internalised its mission as an important regional actor. The University provides higher education in the fields represented by its four faculties - Law, Education, the Social Sciences and Art and Design – as well as in Information Technology (IT).

IT is taught in the Department of Research Methodology, which forms part of the unit known as Common Education Services. Teaching in IT commenced in 1997, and since then the course offerings in the subject have

grown rapidly into a full degree programme. IT cannot be studied as a major subject at the University however, and the master's programmes have been established as a solution to overcome this problem.

The first masters' programme commenced in 2000 (ITMO) and the second (NetCom) in 2002. The idea behind these programmes is that students complete a major (82.5 credits) in one of the faculties and take further studies (82.5 credits) equivalent to a major in IT. The resulting programme, in particular the master's thesis, is cross disciplinary, focusing on IT applications in the subjects taught in the faculties.

The following sections describe the aims of the model for the planning, implementation and evaluation of client-centered education, provide background to the research, and present a preliminary model.

## **2. A CLIENT-CENTERED APPROACH**

### **2.1 Background to the research**

Society today has many hopes, expectations and, indeed, demands where university-level education is concerned. University education is often criticized as being excessively theoretical and detached from the needs of working life. Only a limited number of graduates pursue careers as university researchers; most go to work in the public sector or the business world. Yet working life needs, and places value on, many of the goals of a university education. A survey conducted as part of the NetCom project indicates that businesses in the ICT sector value the following:

- a capacity for broad-based theoretical thinking and the ability to examine things within frames of reference;
- the conceptualizing and solving of problems;
- managing and directing projects;
- working at the client interface.

The traditional function of the universities, one set out in law, is to carry out scientific research and to provide higher education that is grounded in that research. Today we see an emphasis on what is known as the 'third task' of universities—one essential element of which is regional effectiveness. Universities are seen as dynamos or motors for their region, with a key role ascribed to their societal effectiveness and interaction with cultural, working and business life. The degree-oriented, academic education has been joined by education that is derived directly from the needs of working life (Sallinen, 2000; ja Virtanen, 2002).

## **2.2 Goals of the research**

Regional effectiveness is one of the central strategic goals of the University of Lapland. The development of educational programs in IT offered at the university can be examined for their relevance to the university's third task. The foci that emerge for this third task are the needs of working life, in particular in the ICT industry, and of the public sector. In this study, the term '*client-centeredness*' in planning and implementing IT education refers to activities that take into account the expectations and needs of the target group and/or the requirements of working life.

From a traditional perspective, the goals of IT are research, teaching, and cooperating with other disciplines to develop new multidisciplinary programs and areas of IT-related research. The focal question is: What kind of an operational model might succeed in combining the needs of the business world / public sector with the university's traditional focus on theory? In this light, the goals of the research are as follows:

- to construct an operational model which makes it possible to plan and implement educational programs that serve the educational organization's key clients, such as the public sector and businesses. The programs created must give due consideration to the educational and quality-related goals of the educational organization, e.g., a university. The model is referred to as *the client-centered model for the planning and implementation of education*.
- to apply the model to the planning and implementation of an educational program and to assess the effectiveness of the model.

The latter goal requires that the model include methods and tools for the different phases of planning as well as for the assessment of the education implemented.

## **2.3 Client- or market-centered?**

In an examination of adult education policy in the 1990s, Varhola (1996) identifies changes that have occurred in vocational adult education centres. These have prompted a reform of funding procedures and an emphasis on market-centeredness; i.e., the education is funded by the clients. In such a context, educational organizations must pay sufficient attention to the marketing of their programs and to the planning of content. Tuijman (1992) presents the following as the distinguishing features of the market model of adult education:

- a belief in the economic benefit of the education;
- an emphasis on vocational training;
- a diminishing role for the national government in decisions on education;

- demand /client needs are taken as the basis for planning;
- the effectiveness of education is measured;
- educational decisions arise through cooperation between corporations.

The client-centered model that is being developed as part the present research is close in its goals to the market model of education. The fourth of the features presented above is particularly salient.

The client-centered model differs from the market-centered model in at least the following respects:

- the use of the model in the university context is justified in terms of the university's third task. Rather than concentrating on individual clients or businesses, the model focuses primarily on regional effectiveness as well as the development of cooperation between the university and business life/ the public sector in the region.
- the model takes into account the goals of a university education and attempts to reconcile these with clients' goals.

### 3. METHODS

The principal method used in the present research is *constructive research that emphasizes innovation and goals*. Here, the object of research is approached from the perspective of *action research* (Järvinen & Järvinen, 2001). The research encompasses *evaluation research*, whose function is to examine the use and impact of the innovation generated, i.e., the operational model.

The following are foci of our action research agenda that emphasizes innovation and goals:

- the combining of the educational goals of the university and the business world and the furthering of the university's regional effectiveness are considered innovative activity.
- the specification of the target situation, i.e., the operational model, is an essential aspect of the research process.
- the researcher has participated actively in the planning and implementation of the programs presented.

The present research involves the planning, implementation and analysis of at least two degree programs using the new operational model. The results will be used to create a theory, i.e. a framework, for the model, and a constructive model of educational planning. The evaluation research will assess the quality and results of the educational programs planned and implemented using the operational model and will determine the impact of the model on the work of the educational organization, the Department of Research Methodology. An literature analysis will be carried out in order to

ascertain the relevant systems of concepts, methods and planning models. The goal of the analysis and comparison to be conducted is to demonstrate the validity of the model as well as the contribution made by the research. The research will yield new concepts, procedures and techniques for the planning of education in IT.

#### **4. A CLIENT-CENTERED MODEL**

The construction, use and evaluation of the model will take place in the context of two extensive degree programs in IT being implemented at the Department of Research Methodology. One is the NetCom (Network Competence) project, begun in 2002, the other the SEMEL (Services Management of East Lapland) project, which will begin probably in autumn 2003. Table 1 below summarizes the projects:

*Table 1. The NetCom and SEMEL projects*

	<b>NetCom</b>	<b>SEMEL</b>
Clients	ICT industry in the Rovaniemi region, organizations and businesses making extensive use of ICT, including the public sector to a certain extent	The public sector and business life in East Lapland
Funding	ESF, Finnish Ministry of Education, corporate and municipal financing	ESF, Finnish Ministry of Education
Education	Education leading to a university degree, client-centered courses tailored to client needs	Education leading to a university degree

- The operational model has been constructed using a heuristic approach;
- the first version of the model is being used in planning and implementing NetCom. Application of the model in NetCom will yield a new, refined version of the model.
  - the refined version of the model will be applied in the SEMEL project

#### **5. THE PRELIMINARY MODEL**

Figure 1 presents a preliminary version of the operating model, which is being applied and refined in the NetCom project. Operational model represents the multidisciplinary research practice (also known as integration

between different fields of study) and methodological dialogue of applied information technology used in the Department of Research Methodology.

Purposes of the operational model is the multi-methodological research practice, in which:

- Use of the qualitative research methodology and modified method of the IT are combined,
- SSM methodology is applied (Checkland 1981) to the transformation process of the educational organisations.

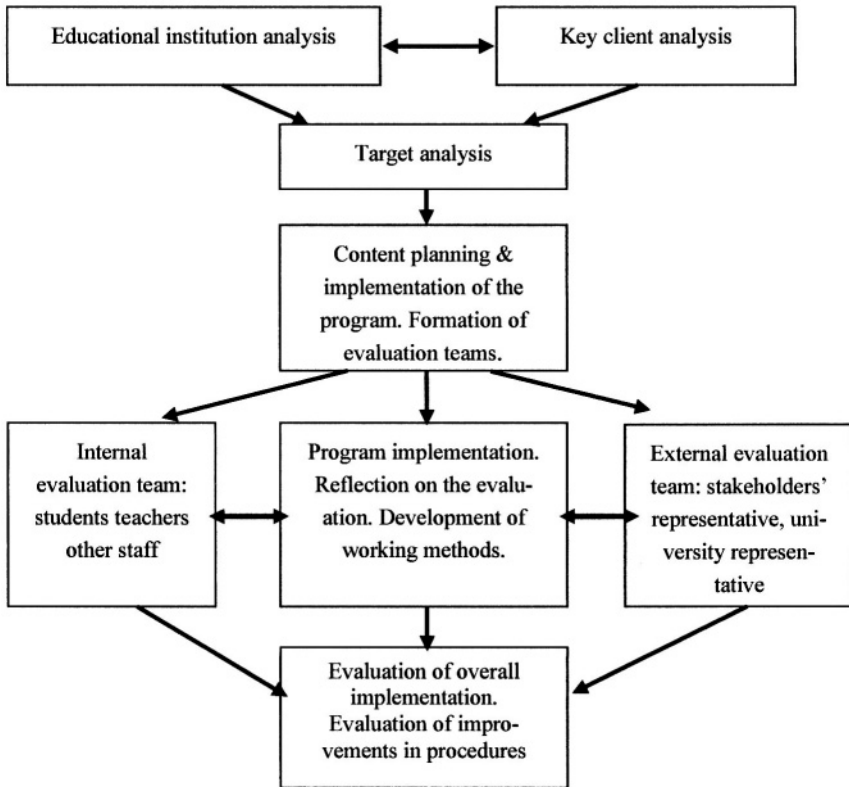

Figure 1. The preliminary version of the operating model

An example of the transformation process is the Department of Research Methodology whose teaching, content of teaching, resource allocation and tasks are strongly influenced by the NetCom and SEMEL projects.

The central concept in the model is the key client, or constituent, who represents the target group for whom the educational program is planned. Key clients may be ICT businesses or university students (or a subset of

these) or persons on the open market who have a certain know-how/educational profile.

Key client analysis of the NetCom project mapped educational needs and willingness for cooperation in the NetCom project from the ICT organization, new media organizations and organizations making extensive use of IT in the Rovaniemi region. Financial funding was expected of the cooperation partners: in return the NetCom project offered research in the form of a master's thesis. There are seven cooperation partners including all the largest software houses and IT services producers in the Rovaniemi region. Representatives of the Department of Research Methodology and the cooperation partners form an IT cooperation group. The IT cooperation group represents innovative attitude of the operation model. Professionalism, consultation and quality of the education evaluation are the characteristics that describe the IT cooperation group. One aspect of the IT cooperation group is to plan new cooperation projects.

The NetCom project includes both Masters School leading to a university degree and also educational services offered to the clients. The educational services include designing and carrying out of tailored study modules for the clients and also the right to study whole entities.

## **6. SUMMARY**

The research described will take place during the period 2003 to 2006. At this writing (February 2003), the NetCom project has begun and its client businesses comprise the key business in the ICT industry in the Rovaniemi region.

The first refinement of the operational model has been carried out, and the division of the model into component phases has also been refined. The content of each phase has been specified in more detail and appropriate methods have been chosen and developed for carrying out the phases.

When evaluating the operational model and the NetCom project, the actual negative experiences aren't. The positive results so far are:

- The NetCom project itself. The project required funding from the enterprises. The operational model created a frame for the concept of cooperation.
- Creating of the network between the university and ICT organisations in the Rovaniemi region. The essential part of the network is the IT cooperation group.
- Study modules tailored for the clients. These study modules enrich teaching at the Department of Research Methodology because students of



the University of Lapland are also able to attend the courses tailored for the clients.

The goal is that by the end of 2006 the research will provide the university with a model that is applicable to the planning, implementation and evaluation of client-centred IT education. This will be a model that has been developed and validated in two extensive degree programs and will have a significant impact on the development of the activities, teaching and research of the Department of Research Methodology.

## REFERENCES

- Checkland, P. (1981). *Systems Thinking, Systems Practice*. John Wiley & Sons Ltd.
- Järvinen, P., & Järvinen A. (2001). *Tutkimustyö metodeista*. Opinpaja, Tampere.
- Sallinen, A. (2000). *Jyväskylän yliopiston avajaispuhe 2000*. retrieved 19.06.03 from <http://www.jyu.fi/tdk/hallinto/rehtori/puhe/avajaispuhe2000.html>
- Tuijnman A. C. (1992). Paradigm Shifts in Adult Education. in A. Tuijnman (Ed.), *Learning Across the Lifespan: Theories, Research, Policies*. Oxford: Pergamon Press.
- Varmola, T. (1996). Markkinasuuntautuneen koulutuksen aikakauteen? Tampereen yliopisto. Kasvatustieteiden tiedekunta. *Acta Universitatis Tamperensis*. Series A. vol. 524.
- Virtanen, I. (2002). Yliopistojen kolmas tehtävä. Pole-kuntatieto Oy ja Ilkka Virtanen.

## BIOGRAPHY

Ilkka Kamaja has research interests in the curriculum development. Recent research and development has focused on client-centered education model in the field of Information Technology. Email: [ilkka.kamaja@urova.fi](mailto:ilkka.kamaja@urova.fi). Juha Lindfors' research interests lie in the design and use of e-learning environments for engineering curricula. Recent research and development has focused on developing and implementing a learning environment for Control Engineering that combines new learning methods and ICT tools. Email: [juha.lindfors@urova.fi](mailto:juha.lindfors@urova.fi)

# **BREAKING NEW GROUND IN PROFESSIONAL IT-TRAINING**

*A System of Career Paths in Information Technology*

Walter Mattauch and Matthias Rohs

**Abstract:** The *Working Process-oriented Continuing Training* project of the Fraunhofer Institute for Software and Systems Engineering has developed and evaluated a new form of continuing vocational training. This project was conducted in cooperation with leading IT enterprises and well-known education institutes. In contrast to other initiatives for structuring the continuing IT-training system, the methodological-didactical transformation of the concept was co-developed during the institute's reorganisation. In the following article, the formal background, as well as the didactical and technological concept, are illustrated. If the concept is put into action as expected it will constitute a decisive turning point in the vocational training system in Germany and will thus be an example for a European initiative.

**Key Words:** Vocational Education, Government, Information Technology

## **1. THE BASIS FOR REORGANISING THE CONTINUING IT-TRAINING SYSTEM**

As a contribution to the Alliance for Work, Vocational training and Competitive Capacity, in 1999 the representatives of employers and unions in the IT-sector and the German Telekom AG developed a policy for the future design of the continuing IT-training system. On the basis of this policy, the Federal Ministry of Education and Research (BMBF) ordered the elaboration of a new continuing vocational training system.

As a result, a system consisting of 29 specialist, 4 operative and 2 strategic professional profiles was developed - see Figure 1 below. The Fraunhofer ISST was commissioned by the BMBF to design and elaborate reference processes as a quality standard for the designated occupational profiles. The Fraunhofer ISST was also commissioned to develop and test a working process-oriented continuing training method in an operational

context. The application of new media and modern communication infrastructures was to ensure that learning was widely realised at the workplace and within the working process.

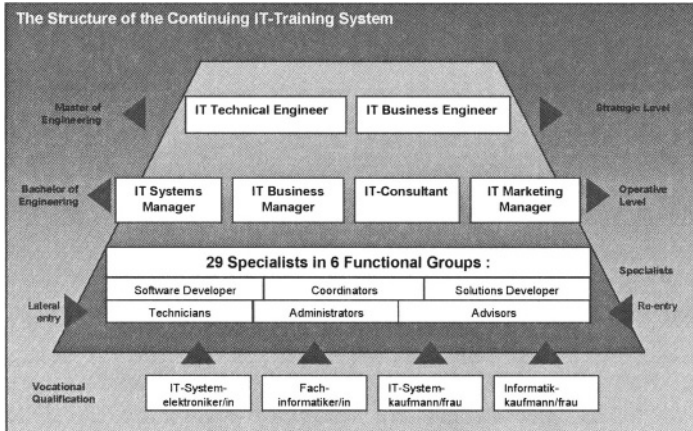

Figure 1: System of Continuing IT-Training

## 2. REFERENCE PROJECTS AS CURRICULA

In the development of the concept of *Arbeitsprozessorientierte Weiterbildung* (APO), real-life requirements and projects formed the basis of the objectives of continuing vocational training. Thus, working processes characteristic of an occupational profile are processed in a generally valid form as reference projects.

Curricula in APO are reference processes that determine mandatory qualification objectives for each profile. These must not be misunderstood as learnt-by-heart knowledge; they are rather generalised descriptions of a project. The reference projects are the measuring unit for the projects that enable the participants to realise and pursue their continuing vocational training. Practice and the participants' pre-knowledge determine the specific and obligatory contents; the reference projects determine the level, complexity and the range of skills and competencies.

The reference process (Fig. 2) represents a typical procedure on a comparatively high level of abstraction. It starts off with an initiative event, for example a client request, followed by a profile-specific subsequent stream of operations like analysis or implementation and ends with a final event like handing over a system to a client or a client instruction.

The reference process reflects a practice-according sequence of all operations within a profile. On the grounds of the reference project at hand, the participant or the organization chooses an appropriate, so-called ‘training project’. The latter must resemble the reference project in structure and complexity to be acknowledged in the continuing training measure. The open and neutral quality of the reference projects permits choosing various training projects.

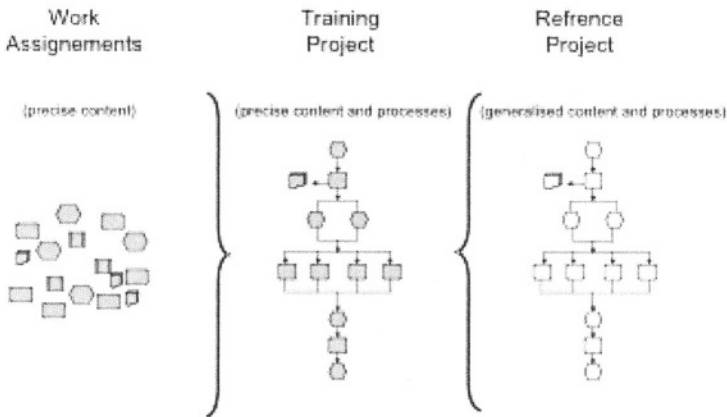

Figure 2: Reference processes: from practice - for practice.

The reference project then structures the complete subsequent training programme. Particular tasks arise from the training projects and their inherent challenges like for example short-term obtaining and configuration of a router. The participant sets up a documentation of the operations in the training project.

Apart from the actual contents, this documentation also contains descriptions of key situations like personal challenges. It serves as a basis for the participant certification that will prove the level, complexity and range of acquired skills in the run of the continuing training measure (Grunwald & Rohs, 2002).

### 3. APO FURTHER EDUCATION AS A COMBINATION OF LEARNING AND WORKING IN TRANSFER PROJECTS

Working process-oriented (APO) continuing vocational training methods are those facilitating a variable combination of learning and working – a ‘blended’ learning model. They necessitate a renunciation of the traditional separation of instruction and learning from daily work. In a traditional seminar, practice is merely used to test previously acquired, often theoretical, matter. On the other hand, in the APO-continuing vocational training model, ways of learning directly in the workplace are a central element – the starting point and frame of reference for learning are the precisely defined professional tasks and working processes. This, in particular, speaks of a highly participant-oriented training.

Competencies are acquired predominantly in the workplace; this demands a high degree of personal organization and the ability to learn independently. The trainee is provided with a coach to assist in developing and extending these skills. The trainee should, moreover, be given creative space in the working area according to the assigned tasks and learning habits. Special attention should be paid to the following:

- making sure that learning processes are not prevented by the trainee’s constant involvement in tasks other than the project;
- ensuring a sufficient amount of time for learning in the working process;
- preventing the trainee from disturbance by the working processes of colleagues;
- providing sufficient support in the learning and working process.

The initiative for learning has to be the participant’s. In the conduct of the training, responsibility must also be carried by:

- *the team of colleagues*: it supports learning processes of the participant by expert exchange and relieves him of some of his duties in order to increase his focus on the training projects.
- *the coach*: is responsible for safeguarding the long-term acquisition of skills. In regular reflexive conversations, the coach advises the trainee on the procedure and organization of his learning process and fosters the trainee’s skill to learn independently by reflecting the trainee’s experiences (while learning) and advancing existing informal learning strategies.
- *experts*: in the case of job-related questions that the trainee is unable to solve alone, one or more experts should be provided for consultation. This applied to general, as well as specifically professional, questions. The exchange with experts supports the trainee in adjusting the approach

- to in-firm conditions and gives advice in choosing relevant business matters.
- *education providers*: an in-firm or external education provider organises the training programme. This consists of putting together learner groups, holding information events, the training and provision of coaches, integrating the trainee into a learning and cooperation platform, spotting or providing adequate learning and information resources (CBT, books, periodicals, links etc.) as well as defining persons who will support the trainee in the conduct of the training programme.

#### **4. DIDACTICAL AND TECHNOLOGICAL SUPPORT OF A WORKING PROCESS-ORIENTED CONTINUING TRAINING**

A set of different media will support the launch of the APO–continuing training measures in the company – the trainee in the learning process, the coach and the experts in their respective function, the organizers in coordinating the training measure.

During a working process-oriented continuing training programme, the participants' learning is often driven by urgent real-life tasks in projects. Knowledge gaps thus have to be closed promptly and pragmatically beside the actual, ongoing normal work. Ideally, and in total, all of the pieces of information necessary for coping with the training projects should be at the trainee's disposal.

In conducting this project, the Fraunhofer ISST has developed a new tool for learning while working – the so-called APO-pilot (see Fig. 3). This device is designed to particularly support learning while working. The APO-pilot realises E-Learning in a process-oriented way by connecting information and cooperation supply to an interface that depicts the reference processes. Such a scheme of depicting and organising information consistently resumes the process-orientation of the IT-further education system. In the sense of a didactical reference process, process models are augmented with information in a way that inspires and supports a self-directed learning process of the trainee while working on a transfer project.

The APO-pilot facilitates a depiction of processes on several levels: the level of reference processes, the level of sub-processes, and the level of single operations in the sub-processes. The individual process steps are linked with descriptions, material and communication supply on every level. The learner chooses relevant information on the basis of the process steps and then has the opportunity to exchange personal knowledge with other

learners or experts. Users of the APO-pilot can extend the primary supply according to their own needs. Thus, a growing knowledge base built on the acquired information and learning experiences of all associates is produced.

In the simplest case, the APO-pilot is merely a technically supported illustration of reference and sub-processes with attached descriptions. The participant can 'fly through' the reference-processes and sub-processes via a so-called cockpit and arrives at the sub-processes via respective functions of the reference processes.

This supply can be added to by providing various learning materials. With the possibility of administering these materials cooperatively and the supply of discussion forums, the APO-pilot evolves into a process-oriented communication platform, the *APO-copilot*. This cooperative administration of materials means that every participant can attach material to the individual process steps for others to comment on.

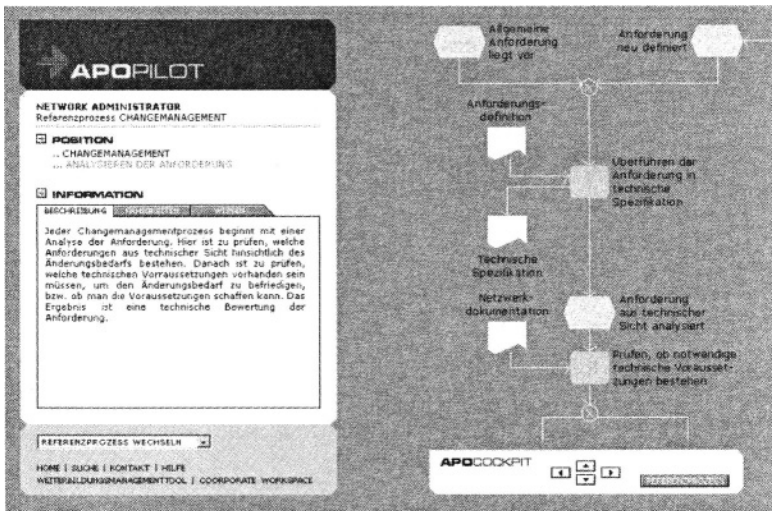

Figure 3: The APO-Pilot of the Fraunhofer- ISST.

## 5. CONCLUSION

The Continuing IT-training measures with the APO-concept sets new standards in three ways:

- Through the development of process-oriented curricula, which are generated from practice in an analysis of actual working processes.

- Second, an essential standard is the integration of learning and working in transfer projects — relocating continuing vocational training in the companies.
- Third, IT-continuing training measures with the APO-concept come with a certification that contains Federal and Europe-wide recognition of the certificates, thus creating a vertical, as well as horizontal, system of incorporation of university degrees.

The continuing IT-training of the operative and strategic professionals is regulated by public law in form of an executive order law according to the Law of Vocational Training §46 (Bundesgesetzblatt, 2002). In contrast to that, a continuing vocational training of specialists in the non-public law area is regulated by a branch-overlapping certification procedure in accordance with European norms (Gamer & Grunwald, 2002).

The new standards offer considerable advantages to employees and companies. Employees have individualised continuing training instead of conventional and rather general seminars. During this training, the employees are accompanied by a coach and supported by appropriate learning material. This training takes place within the context of everyday work and involves actual working processes in the company as the most important fundament of a truly practice-oriented qualification.

The APO method consistently realises the principle of life-long learning. Moreover, working process-oriented continuing training substantially contributes to advanced in-house knowledge management. Between May 2001 and March 2002, an APO-method continuing training programme was successfully implemented with the Deutsche Telekom AG, finishing with the vocational qualification of a network administrator. The project was awarded the Further Education Innovation Award in 2002.

## REFERENCES

- Bundesgesetzblatt, (2002, May 17). *Teil I*, Nr. 30, Bonn.
- Gamer, M. & Grunwald, S. (2002). Personalqualifizierung – Ein europäischer Weg zur Qualitätssicherung in der Weiterbildung. In W. Mattauch & J. Caumanns (Eds.), *Innovationen der IT-Weiterbildung* (pp. 87- 99). Bielefeld: Bertelsmann.
- Grunwald, S. & Rohs, M. (2002). Certification Concept for Work-based Learning, In *Proceedings of New Patterns of Learning in Higher Education: Exploring issues from combining work placement & study*. (pp. 56-67), London: City University.
- Rohs, M. (2002). Workflow-Embedded Training in the IT Sector, In D. Watson & J. Anderson (Eds.), *Networking the Learner. Computers in Education*. (pp. 803-811). Boston, Dordrecht & London: Kluwer Academic Publishers.



**BIOGRAPHY**

Dr. Walter Mattauch studied pedagogy at the College of Education in Freiburg. His doctoral thesis in E-Learning was undertaken at Eberhard-Karls-University of Tübingen. Since 2000, he has been a staff member of the Fraunhofer ISST and has been responsible for project coordination in different contexts of further education. Matthias Rohs studied pedagogy, sociology and psychology with an emphasis on media psychology and media didactics at Freie Universität Berlin. Since 2000, he has been a member of the scientific staff at the Fraunhofer ISST and has been responsible for designing didactic concepts.

# TAKING THE E-TRAIN IN UNIVERSITY EDUCATION

## *Directions for Research*

Anne McDougall, Ted Clark and Lyn Campbell

*Department of Science and Mathematics Education, The University of Melbourne. Victoria 3010, Australia*

**Abstract:** This paper looks at the increased use of e-learning in university education. Acknowledging the origins of the term in business and industry settings, it outlines features of e-learning in university contexts. It suggests some directions for research on the use of e-learning in university education, particularly arguing for research endeavour focused on issues specific to what is novel in e-learning, but building on findings from educational research in earlier more limited technological environments.

**Key words:** higher education, research, open learning.

## 1. INTRODUCTION

While the use of the term 'e-learning' originated in business and industry training contexts, many universities now offer online courses and degrees, describing their strategies for teaching and learning as following the 'principles of e-learning' (e.g., Laurillard & McAndrew, 2002; Mason, 2002). These principles include many of the features that were previously claimed for online learning and distance education, or virtual teaching and learning environments. This paper is interested in the issue of whether e-learning should be identified as a business strategy or has some origin in educational research and practice. Further the paper argues for close scrutiny of related claims made by some that e-learning provides or requires a new kind of learning (ASTD & NGA, 2001; Mason, 2002).

The paper looks briefly at the origins of the term e-learning, considers its transition into university settings, and examines the extent and ways in

which this provides a truly novel approach in university education. It argues that research should focus on aspects of e-learning that are truly novel while building on findings from previous research.

The term e-learning has been used in training contexts for some years. Previously, computer-based training commonly involved an individual learner working at a computer, typically with material presented on CD-ROM. While e-learning does not exclude CD-ROM-based materials, it is now often characterised by distributed, team-based knowledge creation and sharing. In some business profiles this approach supports what Senge (1992) called the 'learning organisation'.

This does not mean these organisations are trying to become organisations for learning like universities. By contrast the practice of learning using the e-learning label as a foundation for the development of a 'learning organisation' may be an alternative to, or in opposition to, the lectures, tutorials and practical classes most commonly associated with academic learning in university settings. In such learning organisations, the role of e-learning is to empower employees to confront and manage change by providing them with access to appropriate situated lifelong learning resources, often in a 'just in time' mode.

## **2. E-LEARNING AND UNIVERSITY EDUCATION**

Given the extensive involvement universities have had in pioneering and developing the use of technologies for learning, it is appropriate for universities looking to utilise e-learning approaches, to consider what aspects of it are similar to previous types of technology enhanced learning, particularly where these aspects have already been well researched.

In academia, as in industry, there is much use of the available technologies to support informal learning opportunities, with an emphasis on promoting networking among professionals. This is evidenced by the widespread and extensive use of e-mail and the World Wide Web for these purposes. Industry and academic advocates of e-learning both draw on beliefs that social interaction aids in the construction of knowledge, and see information and communication technologies as a natural ally in this. This focus, can be attributed on the business side to the convergence of management theories emphasizing systems thinking (Senge 1992), knowledge management (Brown & Duguid, 2000) and organisational learning (Argyris & Schon, 1996). On the academic side it developed alongside learning theories emphasising situated learning (Lave & Wenger, 1991), distributed learning (Salomon, 1993) and communities of practice/learners (Wenger, 1998). Collis (1994) highlighted the similarities

in concerns with learning between industry's use of computer supported cooperative work and education's computer supported cooperative learning.

### **3. WHAT IS NEW IN UNIVERSITY E-LEARNING?**

In universities the term e-learning is used to describe a range of technology-related teaching activities, such as the enhancement of traditional campus-based learning with the integration of course related material on websites (Palloff & Pratt, 2001). E-learning, as a term, is a way of referring to a new integrated communication approach that is not limited to previous online access or presentation based modes that are now seen as predominantly one-way, delivery-only systems. It is particularly used to describe the use of internet-based technology to enable provision of teaching and learning activities that can cater for students in geographically different locations, learning at different times. This includes a recognition that tailoring relevant courses of study requires access to materials, other students, lecturers and tutors in ways that may not be timetable or place dependent. Although this is consistent with some of the just in time goals of industry based e-learning, in university contexts it is likely to follow a more traditional approach, setting out a course of study with lecture materials, references, assessable tasks and online student-lecturer discussions; it follows a lecture/tutorial/essay system that, although online, is familiar to any campus based university student (Salmon, 2000; Laurillard & McAndrew, 2002). What is regarded as new and different in the university e-learning approach is the value placed on the interpersonal communicative aspects of e-learning, in contrast to the earlier web-based learning approaches that used the technology primarily for access to and interaction with course content (Garrison & Anderson, 2003).

Criticism of e-learning at university levels extends from arguments that e-learning is simply a new name for already existing online learning practices (Mason, 2002), to studies that identify online teaching and learning approaches at university level as operating to the detriment of other forms of face to face teaching and learning at university (Brabazon 2002). Authors such as Hara and Kling (2000) and Mann (2003) criticise online learning practices that do not have a social component. Greenagel (2002) identifies the failure of much online teaching to embrace constructivist pedagogies.

In this context of reappraisal of online learning and its value for higher education it must be acknowledged that the term e-learning is used with some variety of meaning in university education. Re-visiting the motivations for adoption of e-learning outlined earlier, we note that little there is genuinely novel. Many attempts have already been made to increase the

effectiveness and efficiency of education through computer use, and claims that the use of technology might enable new kinds of learning have been made more than occasionally throughout the history of educational computing (Hiltz, 1998; Clark, 2000). Further, research into the use of e-learning environments may well provide an opportunity to elucidate, in social and collaborative situations, the complex processes of learning itself but it has not yet been established that the form of learning required is substantially different from general principles of learning in social settings.

#### **4. RESEARCH ISSUES IN E-LEARNING FOR UNIVERSITY EDUCATION**

The development of e-learning in university education must of course be accompanied and informed by sound research. In this context we argue the importance of an awareness of previous work in educational computing. Research on e-learning in university education should utilise the findings of research using earlier technologies and take this further by focusing on what is different in e-learning environments. A suggestion would be to specifically look at those aspects of learning that might be associated with the increasing sophistication of technologies. Findings from earlier work, for example, on issues in human-computer interaction and interface design for learning, might well apply as appropriately in contemporary technological contexts but screen layout and amounts of material presented might also take into consideration better screen resolution and faster delivery of multimedia material. Similarly, behaviourist approaches to computer-based learning found to be ineffective with early computers will not necessarily be more effective if presented with the improved “colour and movement” available now.

It is beyond the scope of this paper to attempt to delineate a full range of research issues for e-learning in university education; we shall use just some examples to illustrate the approach we advocate.

Consider the issue of the use of online Learning Management Systems (LMSs) in university e-learning. Some lecturers take on board the LMS approach, utilising the modular structure and management facilities provided to present to students the material and activities for a course. In our experience, others prefer to develop their own distinctive, possibly idiosyncratic on-line materials and activities, in ways determined perhaps by the nature of the ideas and concepts to be studied in the course, or by the lecturer’s preferred teaching style and strategies, or by a desire to provide a particular type of learning environment. LMSs are software environments into which teachers without programming expertise can enter and manage

learning content and enrolments, but these are not new; the author language environments of the 1970s were designed for exactly this purpose. Early computer-managed learning systems attempted to carry out many of the learning management functions of the present online learning management systems. In the light of the failure of author languages and computer-managed learning systems to gain widespread use or to provide environments for any notable improvement in understanding of, or practice in university education, research into whether standardised learning management systems interfere with content or learning contexts or preferred styles in e-learning is clearly warranted. Documented reasons for lecturer resistance to author language use should be re-examined in terms of the now more sophisticated LMSs. Walsh (Walsh, 2000) suggests that teachers' resistance is linked to more than technological issues, and includes concerns about pedagogy, critical literacies, industrial implications and the socio-emotional transitions linked with change.

An important issue for consideration by university teachers developing e-learning courses is the extent to which the online course can or should imitate or differ from traditional campus-based teaching (McDonald, 1995). Some work here suggests that even with deliberate attempts to make the e-learning experience as similar as possible to the on-campus one, achieving this is very difficult, perhaps impossible. Indications are that the new technologies are not only different learning environments but the content that can be covered in those environments is different from that covered in more traditional university settings (Murnane, 2003; Mason, 2002). We should note from earlier research on technology-supported learning environments that simple experimental studies comparing the "new" with "traditional" methods inevitably reveal few if any significant differences, and tell us very little that is of value. More complex, usually qualitative studies are far more likely to provide useful findings in this area.

Another aspect of e-learning that is associated with established educational theory is group interaction enabled by online discussion (Laurillard & McAndrew, 2002). Again early work indicates that online discussion does not (cannot) duplicate tutorial or face to face student interaction (Hara & Kling, 2000). Content is accessed differently online and course material can be integrated more easily into online discussion and online teaching and learning environments via the ability all participants have of including hyperlinks to references and support material. The process of integration of direct links to content into online discussions certainly reduces the fluidity of ideas and responses, if the more traditional face to face discussion is taken as the model for what online discussion should be attempting to achieve. It also suggests discussion is based on solid easily verified hyperlinked referencing and therefore a difference in content that is

covered (Murnane, 2003) and also a possible increase in the burden of participating (Hara & Kling, 2000; Mann, 2003). This is certainly an area where research in group based learning might uncover novel elements in what e-learning contributes or subtracts from this learning approach.

Hiltz (1998) points out that online discussion can potentially be more engaging, more inclusive, and perhaps more democratic than in face to face situations. Shy, less verbally articulate, slight of voice or slower respondents can spend time considering their responses before submitting them and have equal access being displayed online. In addition participation online may be made mandatory to indicate attendance (Clark, 2003). This does indicate, as mentioned, an increase in the workload for participants in relation to providing considered, well referenced online contributions (Hara & Kling, 2000; Mann, 2003). But it also means that research into less burdensome participation in e-learning at university level is warranted (Clark, 2003).

Inclusive participation in e-learning, taking advantage of hyper linking content by participants and teachers, suggests a need for further research into a mix of pedagogies around questions of interpersonal communication and the text and hypertext based group processes that are available online via online discussion, chat, email, and now text messaging and online video conferencing. In part the investigation of this question is about how e-learning might provide more engaging, direct and active ways to integrate content into the online communication between participants. Garrison and Anderson (2003) point to the importance of access not only to information but also to what they call online "social presence". This engaging of social presence needs investigation in relation to how higher education might utilise what is appropriate from the business community's use of e-learning to support knowledge management and Senge's (1992) notions of the 'learning organisation'.

Related to the above examples are investigations of such things as: aspects of lecturers' and students' work associated with e-learning including time demands for course development, delivery, maintenance and participation; the nature of the activities required for assessment; effects of increased use of e-learning on campus-based learning and teaching; strategies for use of constructivist approaches to learning and teaching; appropriate amounts and types of interactivity, and variations in this among students. Further, the ability afforded by computer technology to record processes, where previously only products of learning were easily available to researchers, has enabled research into learning processes and individual differences that may be able to advance research of collaborative and informal learning.

## 5. CONCLUSION

What the term e-learning provides for higher education is not a complete break with past uses of technologies in education and research. Business and industry's application of e-learning for just in time learning and interpersonal communication of knowledge via knowledge management systems and networks of computer supported communication point to some differences to university approaches to e-learning that may provide avenues for research. Research on e-learning in university contexts must not ignore findings from previous studies of computers in teaching and learning, even work that used earlier more limited technologies. The focus should be on the more novel issues that are derived from industry perspectives on e-learning or those that are enabled specifically by the new levels of technological sophistication utilised in e-learning environments.

## REFERENCES

- Argyris, C., & Schon, D., A. (1996). *Organisational learning II: Theory, method, and practice*. Reading, Massachusetts: Addison-Wesley.
- ASTD, & NGA. (2001). A vision of E-learning for America's workforce: Report of the Commission on Technology and Adult Learning. Retrieved 19/06/03, from <http://www.masie.com/masie/researchreports/ELEARNINGREPORT.pdf>
- Brabazon, T. (2002). *Digital hemlock: Internet education and the poisoning of teaching*. Sydney, NSW: UNSW Press.
- Brown, J. S., & Duguid, P. (2000). *The social life of information*. Boston, Massachusetts: Harvard Business School Press.
- Clark, J. (2000). Collaboration tools in online learning environments. Retrieved 25/09/02, from [http://www.aln.org/alnweb/magazine/Vol4\\_issue1/Clark.htm](http://www.aln.org/alnweb/magazine/Vol4_issue1/Clark.htm)
- Clark, T. (2003). Disadvantages of collaborative online discussion and the advantages of sociability, fun and cliques for online learning. In McDougall, A., Murnane, J. S., Stacey, C., & Dowling C. (Eds.), *ICT and the Teacher of the Future: Selected Papers from the IFIP Working Groups 3.1 & 3.3 Working Conference*. Sydney: Australian Computer Society, 23-5.
- Collis, B.A. (1994). Collaborative learning and CSCW: Research perspectives for internetworked educational environments. In Lewis. R. & Mendelsohn, P. (Eds.), *Lessons from Learning*. Amsterdam: Elsevier: 81-104.
- Garrison, D. & Anderson, T. (2003). *E-Learning in the 21<sup>st</sup> Century: A framework for research and practice*. New York: Routledge Falmer.
- Greenagel, F. L. (2002). The illusion of e-learning: Why are we missing out on the promise of technology. Retrieved 21/06/03, from <http://www.league.org/publication/whitepapers/0802.html>
- Hara, N. & Kling, R. (2000). Students' distress with a web-based distance education course: an ethnographic study of participants' experiences. Retrieved 26/09/02 from <http://www.slis.indiana.edu/CSI/Wp/wp00-01B.html>



- Hiltz, S. R. (1998). Collaborative learning in asynchronous learning networks: building learning communities. Retrieved 25/09/02 from [http://eies.njit.edu/~hiltz/collaborative\\_learning\\_in\\_asynch.htm](http://eies.njit.edu/~hiltz/collaborative_learning_in_asynch.htm)
- Laurillard, D., & McAndrew, P. (2002). Virtual teaching tools: Bringing academics closer to the design of e-learning. Retrieved 21/6/03 from <http://www.shef.ac.uk/nlc2002/proceedings/symp/01.htm>
- Lave, J. & Wenger, E. (1991). *Situated learning: legitimate peripheral participation*. Cambridge, U.K.: Cambridge University Press.
- Mann, S. (2003). A personal inquiry into an experience of adult learning on-line. *Instructional Science*, 31, 111-125.
- Mason, R. (2002). Review of e-learning for education and training. Retrieved 19/6/03 from <http://www.shef.ac.uk/nlc2002/proceedings/symp/02.htm>
- McDonald, J. H. (1995). Te(k)nowledge: technology, education and the new student/subject. *Science as Culture*, 4(Part 3 (Number 20)), 535-564.
- Murnane, J. S. (2003). Teaching Teaching with Information Technology. In McDougall, A., Murnane, J., Stacey, C. & Dowling, C. (eds.) *ICT and the Teacher of the Future*. Sydney: Australian Computer Society, 89-91.
- Palloff, R. M. & Pratt, K. (2001). *Lessons from the cyberspace classroom: The realities of online teaching*. San Francisco: Jossey-Bass.
- Salmon, G. (2000). *E-moderating: the key to teaching and learning online*. London: Kogan Page.
- Salomon, G. (1993). No distribution without individual's cognition: a dynamic interactional view. In Salomon, G. (ed.), *Distributed cognitions: psychological and educational considerations*. Cambridge, U. K.: Cambridge University Press, 111-138.
- Senge, P. M. (1992). *The fifth discipline: the art and practice of the learning organisation*. Milsons Point, NSW: Random House Australia.
- Walsh, A. (2000). Traditional to flexible delivery (Working Paper 00-24). Sydney: University of Technology Sydney, Research Centre for Vocational Education and Training.
- Wenger, E. (1998). *Communities of practice: learning, meaning, and identity*. Cambridge, U. K.: Cambridge University Press.

## BIOGRAPHY

Anne McDougall, Ted Clark and Lyn Campbell are all members of the educational computing research group in the Department of Science and Mathematics Education at the University of Melbourne. E-learning in university education is currently a major research area for the group. Particular areas of interest for these authors include the socio-material networks of online learning and the role of text-based interaction in shaping teaching and learning practices online (Campbell), online media support for learning and the integration of online learning with social interaction practices (Clark), and design and evaluation of technology supported learning environments in a range of curriculum areas and educational settings (McDougall).



## **SECTION 3: INDUSTRY PRACTICES**

# COMPETENCE DEVELOPMENT SUPPORTED BY DIGITAL MEANS IN A KNOWLEDGE- INTENSIVE COMPANY

*The Case of TietoEnator*

Ari Alamäki and Kalle Mäkinen

*TietoEnator Oyj, Arabianranta 6, FIN-00560 Helsinki, Finland*

**Abstract:** This paper reviews practical experiences in digitalizing competence development in a large corporation. Many practical experiments have shown that building learning portals and purchasing off-the-shelf courses are easier tasks than creating demand and understanding new ways of learning at the grassroots level of an organization. Digital competence development should be seen as a strategic approach rather than as a new operational tool. It is a change process that requires successful showcases, careful plans and strategic steps in the right direction. Blended learning models, which support informal learning at the workplace, should replace older classroom-based learning paradigms. Only in this way can corporations bring their learning into the knowledge-intensive era.

**Key words:** competence development, e-learning, organization

## 1. INTRODUCTION

Investing in people is a much more complicated process than investing in new machines and production lines. In developing human capital in corporate environments we are dealing with many human factors—organizing courses and seminars are only the tip of the iceberg in building organizational learning. The nature of organizational learning is changing because the development of technology is causing industrial countries to evolve from industrial societies to post-industrial societies. Science-based technology and an emphasis on information and knowledge are typical of a post-industrial society (Bell, 1976). Current inventions, products and

services are increasingly created as a result of scientific research and development in multidisciplinary teams and social networks, a phenomenon which differs from that which was typical to an industrial society.

The interaction between higher-order thinking skills and scientific knowledge is emphasized more than ever in developing new products and in creating new services (Alamäki, 2000). This process of change should be more clearly reflected in the present ways of designing learning programs and competence development strategies at all levels of knowledge-intensive companies. Technological development, control, and utilization have been, and still are, directly dependent on our abilities to innovate and solve problems; technology is, and will continue to be, a human activity. We must educate employees who have the ability to learn by doing, solve ill-defined problems, and collaborate in a social environment. Therefore, we should be able to support both formal and informal learning at the workplace.

This article focuses on the possibilities provided by digital means in building a learning organization in knowledge-intensive companies. In this article, we define *digital competence development* as a continuum ranging from separate instruction-centered training events to a longer-term and effective learning strategy and process supported by digital means. When digital competence development is understood as a strategic issue in competence development, its benefits also become clearer. We consider digital competence development a strategically important aspect in an organization's learning and business development. While information management only gathers information, digital competence development makes collective knowledge creation and organizational learning a reality. The objective of digital competence development is to support the existing training and competence management processes in the organization.

## **2. LEARNING IN KNOWLEDGE INTENSIVE COMPANIES**

The ability to innovate and learn new knowledge and skills has become a priority of corporations, institutions and nations. Therefore, many companies seek new ways to respond to the stiffer competition caused by the globalization of markets. It is believed that so-called *digital competence development* makes training and learning processes more efficient and quicker.

In the industrial era, training was often removed from the workplace and situated in training centers. According to research (Lave, 1988), adults' learning is functional and often tied to the situation where it takes place (Hutchins 1995). If a substantial boost in competence development is

desired, a lot of emphasis should be placed on informal learning in the workplace. For this reason, digital learning solutions should support both classroom training and informal learning at the workplace.

These digital learning solutions have many advantages compared to the older classroom training paradigm (e.g., Alamäki & Luukkonen, 2002): Web-based learning solutions are continuously available to users; they adapt better to the needs of knowledge; the content can be updated anytime during the life span of the learning process; the content can be personalized for different target groups and business units; usage of the learning solutions can be tracked by reporting tools. Success in global competition often requires the use of modern digital technologies in competence development, namely digital competence development.

Many companies, however, have failed in their digital competence development initiatives, although there are several success stories as well. Poorly designed learning content is a major reason for weak learning results and poor usage statistics. ‘Electronic reading’ is not ‘electronic learning’, nor does abstract text transfer to effective working practices without concrete illustrations and without involving the learner. Learners are only interested in what they feel, see and can do on the computer screen. Too many companies have begun building solutions without understanding pedagogical and media expertise; learning content should have a direct and practical link to learners specific learning needs and motivation.

### **3. CASE DESCRIPTION: TIETOENATOR**

TietoEnator is a leading provider of value-added IT-services, with 13,000 employees in over 20 countries. It specializes in developing and maintaining business-related IT-systems in a networked world. TietoEnator offers consulting services, software development and integration, usage and web administration, customer product development and program services. These services are based on a strong knowledge of our customers’ business areas and technical know-how. TietoEnator offers e-learning products and services for their customers as well.

In the following we describe how TietoEnator built its corporate-level infrastructure for digital competence development. Based on these experiences, we review the digitalizing of competence development at a general level since experiences and lessons to be learned are quite similar in many companies.

#### **4. HOW DID TIETOENATOR BEGIN ITS DIGITAL COMPETENCE DEVELOPMENT?**

At the end of the last century, a need to promote learning in the areas of new technologies was recognized. Electronic learning was seen as a tool that could increase competencies needed in building high value-added IT-services. At the beginning of 2000, TietoEnator began a project named TietoEnator Academy (TEA), which consisted of several sub-projects. Each sub-project had its role in the TEA project. The sub-projects focused on tasks, such as the building of a learning management system, content production for customized courses, user management and invoicing system, creation of networks with universities and other academic institutions, knowledge management and support services.

In project management, TietoEnator's own project management system, PPS, was used to manage and control the functioning of different sub-projects. The TEA project was controlled by a steering committee. The Content Reference Group was responsible for the content and the collection of learning needs from the line organizations. TietoEnator's ISF-system, which was originally built for the user management and invoicing in online services, took care of user management and internal invoicing. The learning management system (LMS) in the learning portal was also TietoEnator's own solution, which included content management systems, reporting and authoring tools as well as a discussion forum for each content topic. The LMS with user management and invoicing systems, the first customized courses and project organization itself were set up in a short period of time compared to corresponding projects in other international companies.

TEA was launched at the end of 2000. Employees were informed by email and via other marketing campaigns. The course hierarchy consisted of three levels: Basic level courses, Business Area-specific courses and Expert level courses. The first courses were basic level courses aimed at all employees, and they were created by pedagogical and media experts at TietoEnator. Substance experts wrote the screen texts, but other external expertise was not needed in production. The instructional design was based on theoretical and practical illustration with orientation animations about the main issues presented in learning material. Most of them also had pre-tests and final tests, and after completing a course, users could print a diploma with their final test scores.

During the first year, off-the-shelf courses from well-known international companies were purchased in addition to our own content production. The courses focused on programming, computer skills, IT-architectures, languages, marketing, sales and internal processes.

## 5. LESSONS LEARNED OVER THREE YEARS

Experience showed that customized courses with high-quality content presentation were much more successful than the large libraries of off-the-shelf courses. Poorly designed content does not motivate anybody. The pedagogical quality of courses is very important for the transfer of learning: knowledge is not an object that can be transferred from the computer screen to the brains of learners. It is obviously important to deliver useful knowledge, but it has to be linked to concrete examples and practical illustration in order to activate learners' mental processes. This is the only way that the course content supports the effective building of internal schemas or mental models, i.e. people learn by applying new knowledge in meaningful contexts.

The decisions, strategies and operative work that will be used should be created or at least evaluated by experts in digital competence development. It is also important to use pedagogical experts in planning solutions and guidelines. The responsible parties should understand how employees actually learn and how to design and implement pilot projects in practice. For example, programmers and other IT experts have acquired their knowledge by reading manuals, talking with colleagues, accessing discussion areas and using the Internet's search engines as an "information bank". Therefore, it is important to understand the types of learning to which digital means can be applied, what the limitations of digital means are, and what the business benefits are to the organization.

The digitalizing of competence development is not just "an IT-project". Purchasing LMS or any technological system does not digitalize a training process. The definition of vision, strategy and operative processes for digital competence development is more important than many managers believe. They direct development actions, steps and speed of progress – we can seldom bring our organizations into the digital age in one year. Therefore, the nature and structure of the organization, its core processes, learning and management culture and many other issues determine the strategic steps for digitalizing competence development. In fact, they are starting points for the e-learning strategy of an organization.

*"If you build it, they will come"* does not work in competence development. The digitalizing of competence development requires change management. According to our experiences, it is advisable to start with small steps in the right direction that focus on the creation of basic understanding in the business units. The human mind is conservative and organizations run their businesses with established processes – tacit knowledge has a central role in most activities. People do not easily change or reject their routine work practices even if they know new practices are more beneficial than



existing ones. For example, Argyris (1992) reviews this matter in his model about single and double-loop learning in organizations. Issues, which do not require change in determining factors of organization, can be easier to realize. As Senge (1990) says, “*if you push the organization, it pushes back*”. Therefore, during the time you build supply, you must simultaneously create demand and basic understanding at the grassroots level of the organization. This can be done by successful business cases and concrete examples.

Why build expensive and fragmented learning environments if the corporate intranet is already usable as a delivery channel? Fragmented and overlapping IT-systems cause extra costs for the organization (Weill & Broadbent, 1998). For example, the current learning portal at TietoEnator is part of the new intranet system. What learners are mostly asking for is relevant learning content; self-study courses can be delivered and users and content can be managed using the corporate intranet. Collaboration tools, however, have a different purpose than self-study material and are therefore often more individual systems, such as ASP-services linked to the corporate intranet. Hence, in choosing technologies we need to keep pedagogical models in mind; different pedagogical models often require different technological decisions.

In bringing competence development into the digital age, managers are in a key role. Managers’ involvement and personal example to their subordinates as e-learners are essential success factors. For example, in one certain business unit, managers - if only a few – displayed their own final test diplomas beside the door of the office as an example to their subordinates. The managers’ example was found to be very important in the rollout of digital competence development initiatives in the business units.

## **6. HOW TO DEVELOP A LEARNING ORGANIZATION BY DIGITAL MEANS**

In designing learning solutions that support learning in the right form, at the right time and in the right place, we need to pay attention to both informal and formal learning at the workplace (e.g., Alamäki & Luukkonen, 2002; Masie, 2002; Rosenberg, 2001). In designing and creating effective learning solutions, we have to know how people really learn and how their expertise develops in everyday situations. In fact, it is a mistake to focus only on the results of competence surveys, which only reveal what people need to know. For example, although the title of a course may correspond to competence needs, its form of knowledge may not necessarily be applicable to the real working situation.

Since digital competence development is culturally often a new element in the competence management strategy, it turns attention on change management. It is important to build “show cases” or “corporate quick wins” soon after the coaching, definition and other planning. Business unit managers and their subordinates require concrete examples and hands-on experiences in effective learning – the elements that are required in digitalizing competence development.

In developing digital learning solutions, many managers and trainers seldom separate the development of supply-side (software and courses) from the development of demand-side (new learning practices and motivation). For example, the learning solutions can be “technically right”, but they nevertheless fail to answer the actual questions of learners. In addition to this, learning cannot be separated from work or usage context - it cannot be restored to the learning portals or platforms. Therefore, in designing learning solutions, more emphasis should also be put on the learning solutions’ ability to work as performance support systems and tools of social knowledge construction.

The learning content must lead the learners’ cognitive and emotional processes. Focus should be on the integration of knowledge into real cases and situations. According to the theories of cognitive psychology (Anderson, Reder & Simon, 1996), learning is most effective when we combine abstract instruction with concrete illustration; the same method works in the digital world as well.

## **7. CONCLUSIONS**

It is much easier to digitalize the formal learning processes than to encourage informal learning at the workplace. Competence development must not be seen as the mere sharing of knowledge; rather, real knowledge is gained through learning and work processes. It is not uploading to the corporate intranet hundreds of “electronic manuals” containing essential information.

The essential factor in learning solutions is their usability and applicability to teaching and learning processes and, above all, their applicability to support work processes. The supply for learners is very easy to produce, but it is a much larger job to cause a change in the learning culture and to create real demand and motivate learning in the business units.

The pedagogical quality and relevance of content, the coaching of HRD personnel, the definition of strategy and its operative processes, the involvement of managers and the building of successful business cases are

all essential factors in digitalizing competence development in the knowledge-intensive companies.

## REFERENCES

- Alamäki, A. (2000). Technological reasoning as a human side of technological innovation. In I. Mottier & M. J. deVries (Eds.), *Innovation and diffusion in technology education: Proceedings of PATT-10 conference* (pp. 9-15). Eindhoven: PATT-Foundation.
- Alamäki, A. & Luukkonen, J. (2002). *eLearning - digital means of competence development: strategies, content production, technologies and implementation*. Helsinki: Edita.
- Anderson, J., Reder, L. & Simon, H. (1996). Situated learning and education. *Educational Researcher*, 25(4), 5-11.
- Argyris, C. (1992). *On organizational learning*. Cambridge: Blackwell.
- Bell, D. (1976). *The coming of post-industrial society. A venture in social forecasting*. New York: Basic Books.
- Hutchins, E. (1995). *Cognition in the Wild*. Cambridge, MA: MIT Press.
- Lave, J. (1988). *Cognition in practice. Mind, mathematics and culture in everyday life*. New York: Cambridge University Press.
- Masie, E. (2002). Blended learning: The magic is in the mix. In A. Rossett (Ed.), *The ASTD e-learning handbook. Best practices, strategies, and case studies for an emerging field*. (pp. 58-63). New York: Mc Graw Hill.
- Rosenberg, M. (2001, Sep 30). *Building a successful e-learning strategy*. Paper presented at the Online Learning conference, Los Angeles, USA.
- Senge, P. (1990). *The fifth discipline: The art & practice of the learning organisation*. New York: Currency Doubleday.
- Tuomi, I. (2002). The future of knowledge management. *Lifelong Learning in Europe*, 7(2), 69-79.
- Weill, P. & Broadbent, M. (1998). *Leveraging the new infrastructure: How market leaders capitalize on IT*. Boston, MA: Harvard Business School Press.

## BIOGRAPHY

Ari Alamäki (Ed.D) works as senior consultant in e-learning and Kalle Mäkinen (M.Ed) works as a pedagogical concept designer in TietoEnator Corporation, Finland.

# ELECTRONIC MAIL COMPETITIONS

## *Learning Media by Media*

Valentina Dagiene and Gintautas Grigas

*Institute of Mathematics and Informatics, Lithuania*

**Abstract:** The use of electronic mail in learning is discussed, with the emphasis on the results of recent experience gained in Lithuania over the last several years. The public competition using electronic mail and about electronic mail was chosen as an attractive and self-motivating feature. The e-mail competitions take place since 1999 one time per year. In order to make competition more attractive, the participants are invited to play a role of experts, replying to e-mail letters from imaginary novice users of e-mail. The topics of questions were concerned with proper usage of e-mail software and letter writing culture and style. The number of participants varied in the range 73–174. About one half of them were school students. It was observed that the general level of knowledge of participants is raising up from year to year and school students are capable to compete with other participants.

**Key words:** competitions, distance learning, cultural learning

## 1. INTRODUCTION

The number of e-mail users is growing more than 25 percent per year, and e-mail correspondence is evolving from the free short chatty e-mail messages of technical users to the sophisticated documents used by business; being proficient at writing effective e-mail is now an essential work skill. There are now many recommendations, rules, etiquette tips and advice about politic use for improving personal e-mail style (e.g., Angel, 1993).

It is true that e-mail is often written on the fly without time for leisurely review and proofing. It is also true that if you try to improve your e-mail writing using the traditional approach of paper-based communication, you dilute the power of the e-mail medium. That's why developing an effective and timely e-mail writing style is very important for students.

Communication is a powerful tool for encouraging learners to examine new ideas and compare them to their own existing ones. Since e-mail is one of the cheapest and most available means of communication, a fact noticed quite a long time ago e.g., Welsh, 1982, we have started using it for teaching in Lithuania's secondary schools since the middle of 1990s (Grigas, 1993). At first, e-mail was used for distance teaching of programming as well in the Lithuanian National Olympiads in Informatics and the Young Programmers' School. Gradually electronic mail became available to everyone and the teaching focus shifted from technical to cultural aspects. There was also further thinking about teaching e-mail's textual practices, and of conveying deeper and more perceptive knowledge about the use of e-mail for effective communication.

Electronic mail, itself, can be used for such teaching. This paper describes the use of e-mail competitions to enhance students' communication skills. Dagiene (1997) describes some other approaches that have also been adopted.

## **2. ELECTRONIC MAIL COMPETITION – ONE OF APPROACHES FOR IMPROVING SKILLS**

The following assumptions were taken into account in designing a program for teaching about the effective use of electronic mail:

1. Practical activities are more interesting and attractive than theoretical studies for school students, especially for those of lower grades (Papert, 1980).
2. Elements of competition stimulate the learning process.
3. In order to teach electronic mail style, two most important topics should be emphasized:
  - Technical aspects and problems of electronic mail (configuration of the mail program, using an appropriate character set and encoding, work with attachments, etc.)
  - Correct writing of the letter (proper formatting of the message heading, presentation of personal data, etc.)

In order to make these things more interesting to learn, a Lithuanian e-mail competition was first organised in 1999, and continues to this day. The main aim of the competition is to teach learners a sophisticated way of using e-mail and to produce more cultivated letter writing.

### **3. THE ORGANIZING STRUCTURE OF THE ELECTRONIC MAIL COMPETITION**

#### **3.1 Announcement of the competition and registration of the participants**

The invitation to the competition is announced in the monthly magazine “Kompiuterija” which is concerned with computer matters. The information on the forthcoming competition, the terms of registration, and address of registration are presented. There are two reasons for such registration:

1. *Organizational.* The e-mail addresses of participants are needed in order to send them the tasks details which are not announced in the magazine.
2. *Pedagogical.* The e-mail registration message gives certain information about a participant’s elementary e-mail writing skills, and provides the possibility to point out the mistakes made in the application letter by responding to it.

In regard to teaching, the second reason is far more essential.

#### **3.2 Duration of the competition**

One full workday (from 8 a.m. till 5 p.m.) was reserved for the first competition. However, it appeared that this time was not convenient to all participants: for some of them a more convenient time was a day while for others (those have computer at home) – early morning or evening. Therefore, next year we have prolonged the time of competition to one whole day and one whole night (from midday until midday). This doesn’t mean that participants have to work on the task for the whole day and night, because a couple of hours are adequate to write down the answers. A participant may simply choose the most convenient time to work on the competition.

#### **3.3 Course and results of the competition**

Each participant gets four tasks via e-mail (except in the third competition, when there were three tasks) and has to e-mail the solutions to the jury prior to the closing time. During the competition the e-mails are received, and the questions related technical problems of e-mail traffic are answered. After the competition is over, all e-mail received from participants is examined and considered. The results are announced in the next issue of the magazine. The review of solutions and the correct solutions are also

published so that those readers of the magazine who didn't take part in the competition may also learn some lessons from it.

The participants who win prizes may reclaim them in certain sections of the daily newspaper 'Lietuvos rytas' that are scattered through the country.

#### **4. TASKS FOR THE ELECTRONIC MAIL COMPETITION**

In order to make tasks more attractive, some game elements have been adopted. The task is presented like an e-mail message whose apparent author requests a consultation in one or other issue that is connected with electronic mail. Participants of the competition are assigned the role of an expert. They have to write a skilled and cultivated response as if they were a real expert.

##### **4.1 Character of tasks**

Each participant receives four messages, each containing a single question. These questions should fit (as in each competition) with the following features:

1. There is always one question concerned with the particulars of e-mail software, for example: how to choose the proper encoding of the message, what measures should be taken if some difficulties are encountered while reading the message, etc.
2. At least one question is devoted to e-mail writing etiquette, neat and cultivated writing style: a 'requester' asks how to correct language mistakes, applies for some advice about how to write a message to the serious recipient.
3. The rest of the questions usually are taken from different situations; there are always certain objectives that involve some elements of surprise or uniqueness. They work somewhat like a puzzle.

Not only a correct, clear and full reply is important, but also participants' must have the correct means of sending a message, i.e. each participant must have a computer and e-mail program with the proper settings:

1. The proper character set must be included in the header of the message and should be in correspondence with the message content encoding.
2. The right date, time, and time zone has to be in the message header.
3. In the address field *From*: a personal name should be given as well.
4. The registration message has to have the same subject as it is indicated in invitation to competition. The participants have sent their answers as e-mail replies to the questioners.

The desired culture of e-mail correspondence is delivered in an implicit way by ensuring that participants observe these requirements. During the first two competitions these criteria were used to reduce the evaluation points if these requirements were ignored. However, while this had an influence on the final results, it was noticed later that it has a little effect on learning because participants see their mistakes after the results are announced, and forget them until the next competition.

In the third competition we have changed our tactics. We decided to enforce these rules during registration. If the rules are observed, the application is accepted and the participant receives a registration number. If not, the application is rejected and the potential participant is informed what was wrong in the message and to attempt registration once more.

In order to make registration livelier we have introduced one more type of prize—a lottery where the chances to win depends on the time of registration. During registration the participants are placed into groups of different size: the first group contains only 1 member (No. 1), the second – 2 (No. 2 and No. 3), the third – 4 (No. 4–7), the fourth – 8, and so on. There is one lucky number in each group. So those who did not succeed at registering at the first attempt have reduced chances to win the lottery, but it doesn't have any influence on the main results of competition.

## **4.2 Examples of tasks**

Solutions to each and every task were given in the answers to the inquiry letters. For example, during one competition, four persons – Jonas Jonaitis, Petras Petraitis, Povilas Povilaitis and **Jurga Juragaitė** – wrote inquiring letters. Of course these persons were not real. Their names were made-up in order that the participants of the competition could better empathize with the expert's role and could more naturally show the cultivated communication via e-mail with the particular, but unfamiliar person who is seeking the advice.

The questions were chosen so that the competition participants could have as equal a starting position as possible, irrespective of the operating system or mail program used by them.



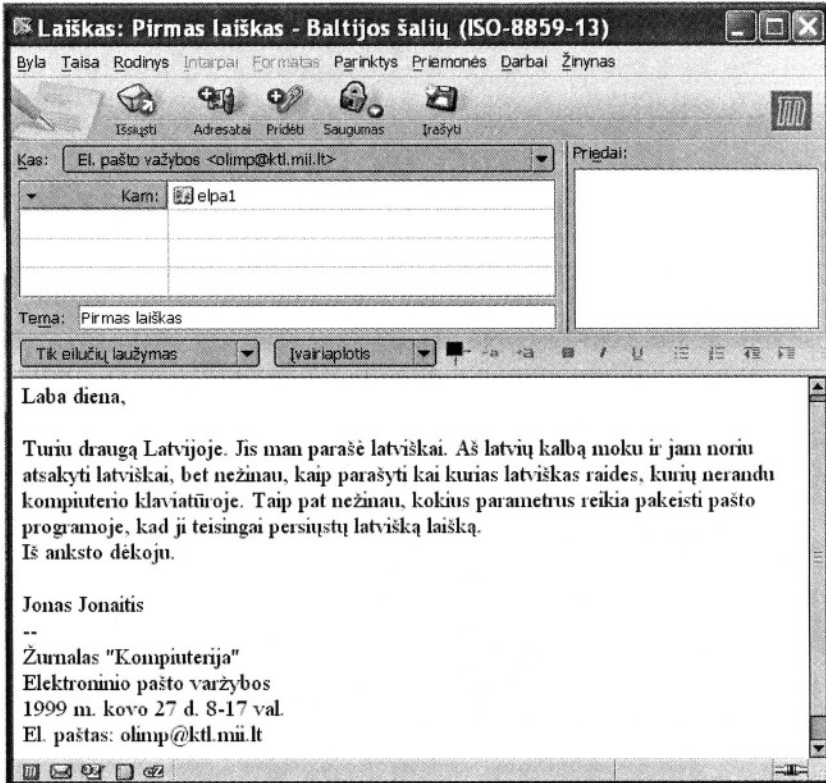

Figure 1. The first message to the participants of the first competition (translation below)

‘Hello, I have a friend from Latvia. He wrote me a message in Latvian. I know the Latvian language and would like to answer him in Latvian but I have no idea how to type some Latvian letters, which are not on the keyboard. Also I don’t know which parameters in the mail program have to be changed that the letter in Latvian could be sent correctly. Thank you in advance. Jonas Jonaitis’

The third message to the participants of the first competition was: ‘Hello, I have got the warning message to be wary of an e-mail with the title “VVV” in the subject field. It was also written that if I try to read that message my computer will get infected with a dangerous virus. I would like to ask, and get a reasoned explanation, whether it is really possible to infect a computer via e-mail. Sincerely, Povilas Povilaitis’

## 5. PARTICIPANTS

Each year there were many participants (Fig. 2).

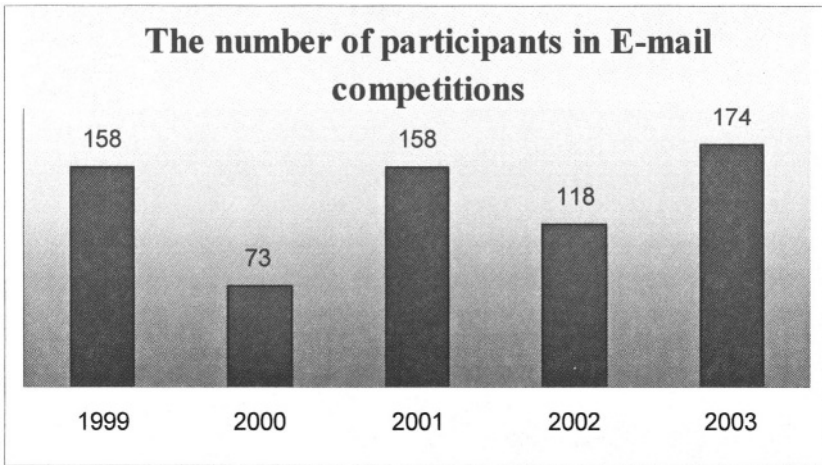

Figure 2. Number of participants in the e-mail competitions

The winners of the first two places in the first competition have received quite precious prizes, CD players, while the winners of other places were received only souvenir gifts. In the later competitions there were only souvenir gifts. However, the number of participants didn't decrease.

Anyone may take part in the competition. Approximately half of the participants were school students. Organizers of the first competition were afraid that school students could have difficulties competing with the professionals (for example, with the mail administrators). Therefore the competition rules had a warranty saying that one of the first two prizes should be given to a school student, i.e., the best school student should win at least the second place. However, it happened that the school students scored enough points to win the first prize. The second place was given to a teacher and the other eight places were equally distributed among school students and other participants. Therefore, in the next competition, there weren't any privileges for the school students.

This was not a major issue—our aim was to raise the e-mailing culture in all spheres, and the privileges that in the beginning were given to the school students have been given simply to encourage them to participate in the competition.

## 6. CONCLUSIONS

Deeper understanding of electronic e-mail is highly important to the language and culture of our country. It's a tool that helps to pay attention on the questions of proper adaptation of the mail programs in the cultural environment. The elements of electronic culture have to be taught using different methods. Electronic mail is one of the most convenient and most often used tool of information technology.

In comparing the results of the competitions, we see that the general level of the participants' skills is rising. The general level of school students skills does not differ much from those experts of informatics.

The price of prizes doesn't have an observable influence on the number of participants. Participants are more interested in the content of competition, then in a prize. It's clear from the messages of participants that they far more enjoy being in the expert's shoes than in the pupil's who has to give his answers to the teacher or jury member.

The sharp-witted answers of the experts give a pleasure to jury members and encourage them to organize e-mail competitions in future.

## REFERENCES

- Angel, D., & Heslop, B. (1993). *The Elements of E-mail Style*. New York: Addison-Wesley.
- Dagiene, V. (1997, Dec. 2-4). Learning via Electronic Mail: What and How? Paper presented at the *Education for the 21st Century conference*, Cape Town, South Africa.
- Grigas G. (1993). An experiment of computer programming practice by e-mail. *Interpersonal Computing and Technology*, 1(2), 1-10.
- Papert, S. *Mindstorms: Children, Computers, and Powerful Ideas*. Basic Books. N. Y., 1980.
- Welsh, L. A. (1982). Using Electronic Mail as a Teaching Tool. *Communications of the ACM*, 23(2), 102-108.

## BIOGRAPHY

Valentina Dagiene is the head of the Department of Informatics Methodology at the Institute of Mathematics and Informatics as well as an Associate Professor at the Vilnius University. She has published over 80 scientific papers and the same number of methodical works, has written more than 30 textbooks in the field of informatics for high school. Her main research focus is teaching informatics and information technologies in primary, basic, and secondary school, localization of software, teaching Logo, problem solving.

Gintautas Grigas is senior research worker of the Department of Informatics Methodology at the Institute of Mathematics and Informatics. He has published over one hundred scientific papers, about the same number of popular articles, and 32 books in the field of programming

and teaching of programming. His main current research focus is Internet software localization.



# INTEGRATING NEEDS ASSESSMENT WITHIN NEXT GENERATION E-LEARNING SYSTEMS

*Lessons learnt from a case study*

<sup>1</sup>Dieuwke de Haan, <sup>2</sup>Patrick Waterson, <sup>3</sup>Sonja Trapp and <sup>4</sup>Dietmar Pfahl

*Fraunhofer IESE, Sauerwiesen 6, DE-67661 Kaiserslautern, Germany e-mail: {<sup>1</sup>dehaan,<sup>2</sup>waterson, <sup>3</sup>trapp, <sup>4</sup>pfahl}@iese.fraunhofer.de*

**Abstract:** In this paper we outline a method for systematically addressing needs assessment (QUALISEM-PEOPLE), alongside a case study of its use within a medium sized, German company. The method was designed in order to provide guidance in analysing skill and role competences, particularly when e-learning systems are being considered for training purposes. The method proved to be successful within the company and helped to profile actual and target qualification needs, as well as employee preferences. In addition, there were also a number of overall lessons that could be learnt from the case study. These mainly relate to the need to integrate needs assessment within the broader context of Human Resource Management (HRM) systems, as well as the importance of employee participation within the process. We end the paper with a discussion of possible extensions to our work as well as outstanding challenges within the area

**Key words:** Industry Training, Self-assessment, Software Engineering.

## 1. INTRODUCTION

A number of studies within the broad subject of e-learning have examined the evolution of different types of systems over time. First generation e-learning systems, for example, were often seen as a substitute for classroom training, on-line courses tended to be developed as direct analogues of conventionally delivered courses (Darby, 2002). E-learning was viewed mainly as an individual training tool that could be used to provide training in the learners own time, and at their own pace. One of the main drivers for the tools was the expectation that they could help organisations to save money on training costs. However, it soon became

clear that the outcomes from this type of e-learning often failed to meet company expectations. Knights (2002) for example, found that many employees were either not aware of the existence of on-line courses or found them very difficult to locate. In addition, much of the course material involved working through successive screens and modules that were laborious and did not support enjoyment or exploration of their content.

One response to these problems has been the development of e-learning systems that provide courses which are purposely designed for the particular instructional domain, make use of instructional e-learning design guidelines, and offer opportunities for cooperative learning (Darby, 2002). A second response is the move from support-driven towards demand-driven education by making optimal use of Information and Communication Technology (ICT) functionalities (Kirschner and Valcke, 1993). Students can make decisions in relation to two different fields, namely about the content of education and concerning the didactic elaboration. These systems incorporate an intake-module that measures individual learner needs, and learning styles. In addition, the more recent generation of e-learning systems offer possibilities to structure the informal learning process by bridging the gap between learning and professional practice. An example is the concept of the Virtual Business Team (VBT) (van Petegem et al., 2000) developed within the Dutch Open University. A typical VBT workbench provides tools to support collaborative work in a networked environment, tools for assessment and guidance, and tools for knowledge management. These later systems highlight the importance of focusing as early on as possible on the specific requirements and needs of the target population of an e-learning system. In addition, there is a need for methods and tools that offer systematic guidance and support in gathering these types of requirements. In this paper we describe one such method (QUALISEM-PEOPLE), as well as report some experience based upon its use within an industrial case study. The paper is structured as follows: a description of the e-learning needs assessment method QUALISEM-PEOPLE, a case study in which QUALISEM-PEOPLE was used; a discussion of the main lessons learnt and outstanding challenges presented by our research.

## **2. THE QUALISEM-PEOPLE METHOD: NEEDS ASSESSMENT FOR E-LEARNING**

QUALISEM-PEOPLE is part of a larger-scale system (QUALISEM), which is a modular framework for the assessment, evaluation, and certification of software engineering qualification systems. Each module in QUALISEM offers services that help to facilitate decision making with

regard to training and development or to get insight into the quality of the choices that have already been made. The modules cover methods and tools for the assessment, evaluation and certification of various dimensions of a specific part of the software engineering qualification system (i.e., covering people, processes and products). One of the modules, QUALISEM-PEOPLE, deals with the assessment of qualification needs of employees involved in the software developing process. QUALISEM-PEOPLE makes use of a set of customisable standard skill profiles and consists of eight steps.

## **2.1 Use of Standard Role-based Skill Profiles**

In order to save time during the needs-assessment process QUALISEM-PEOPLE makes use of so-called “standard competence profiles”. Within the field of software engineering several accepted competence-based frameworks exist, for example:

- The Career-Space framework is a set of generic skills profiles covering the main job areas for which the European-wide ICT industry is experiencing skills shortages (<http://www.career-space.com>)
- APO-profiles, a German-wide initiative that is focusing on the description of job-profiles in terms of work processes, associated activities and required competencies (<http://www.apo-it.de>).
- ESF-Baukasten (<http://www.iese.fhg.de/ESF-Baukasten/>) describes role-oriented competency profiles for the field of software engineering.

## **2.2 Steps within QUALISEM-PEOPLE**

The method involves eight steps, these are:

1. Selection of an adequate set of standard profiles, specific roles and employees within the company.
2. Tailoring of the standard profiles for each role in order to meet customer needs and to fit in with the specific company context.
3. Assessment of the target profiles based on a role-based questionnaire in which the employees and/or company managers rate desired performance levels for each of the specific competences that are listed in the standard-role-profile. In completing the questionnaire it is also important to take into account the future needs of an organization or department, as well as new methods that may be applied.
4. Assessment of the actual competences on the basis of a role-based questionnaire in which the employees rate their actual performance level for each of the specific competences that are listed in the standard-role profile.



5. Assessment of the qualification preferences on the basis of a role specific questionnaire in which the employee rate for each skill listed whether they wish to be further trained in that skill.
6. Data-analysis of the collected data per role, resulting in the description of actual and target skill-profiles for each role as well as a list of training preferences
7. Comparison and aggregation of the data from step 3 and 4 resulting in a skills gaps analysis at role- and organization- level. Balancing of the skill gaps and qualification preferences at role and organisation level.
8. Stakeholder workshop - the objective of which is to prioritize the skill gaps and identify the preferred ways in which to provide training for them.

### **3. QUALISEM-PEOPLE: A CASE STUDY**

#### **3.1 Background**

A medium sized enterprise and market leader in the development of industrial printing machines took part in the study. The company was introducing new shopfloor machinery, and the main difference between the old and the new machinery was related to the complexity of the software that was built into it. Since most of the employees had a mechanical or electrical engineering and not a software engineering background, it was expected that although having coped very well with the software development and maintenance thus far, the new release might require more up-to-date competencies. The work involved the re-design of the software development process, as well as helping to determine employee qualification gaps.

#### **3.2 Use of the Method**

Roughly 10 person-days were needed for adapting the questionnaires, conducting statistical evaluation, and summarising and presenting the results. Two meetings with the main stakeholders were held at the beginning and end of the study. In addition, briefing interviews with selected employees were performed in order to reassure them of the value of the work being performed. The remainder of the data collection was done via e-mail.

### 3.3 Outcomes

During the initial interviews with stakeholders it was decided that the ESF-Baukasten was to be used as a standard set of skill profiles. Five specific profiles were selected as relevant. Table 1 shows the different roles that were involved as well as the number of employees for which a specific skill profile was expected to be applicable.

*Table 1. Number of employees per role*

Role-profile	Number of employees
Application programmer	17
Architect	6
Designer	11
Requirements engineer	12
Tester	5

Many employees occupied more than one role in the software development process and that it was not always easy for them to distinguish what kind of skill was needed for which role. In order to minimize the required time for completing the questionnaire, role-specific questionnaires were established which contained all of the technical and behavioural skills necessary to fulfil the role. The employees were then asked to perform a self-assessment of their skills, by rating for each competence area their respective development level (actual situation) as well as the needed development level (target situation). Individuals were also asked to state areas of competence that they felt they might require further training. The questionnaire contained information regarding actual, target and subjective qualification preferences for each employee.

The employees were informed about the objectives of the survey prior to receiving the role-specific questionnaires by e-mail. Completed questionnaires were sent back to the researchers and analysed in such a manner that individual characteristics of employees could not be identified. The results were summarized and presented to the management who then decided upon concrete qualification measures or activities.

## 4. LESSONS LEARNT

Our experience in using QUALISEM-PEOPLE provided us with a number of important lessons learnt. In particular, we point to the following lessons that should be taken into account when applying this method.

## **4.1 The importance of viewing needs assessment within the context of larger systems**

In our case study we found that the result of the gaps analysis showed that some gaps were not explicitly related to the newly introduced processes and appeared to have existed for a longer time. In order to guarantee a more continuous tracking of the qualification needs it would be advisable to incorporate the needs analysis in a more comprehensive approach towards reviewing and assessing the larger HRM system within a company. The determination of qualification gaps and associated needs is not a one-shot process, which occurs at one point in time. Instead it may occur at numerous points during the cycle of changes to the work process, the analysis of skills-gaps and the generation of new training requirements for example.

## **4.2 Application of standard role-based skill profiles**

Working with standard profiles within needs analysis is often helpful in gaining time during the overall qualification process. However care has to be taken that the activities allocated to a skill profile within the company correspond to those allocated in the standard set. In other words, the standard-set should be used only as a starting point that might have to be adapted in the light of other information that may only be available later on in the overall process.

## **4.3 Employee involvement**

The main purpose of this survey was to elicit the general level of skill gaps among the employees working in software development. An important lesson was that this should be done by the employees themselves through self-assessment of their skills. Using this procedure they were more directly involved in the planning of their own qualification processes and therefore felt a high degree of ownership of the outcomes. An important factor for the data collection was that their contribution was anonymous and confidential. The involvement of employees in the needs assessment was vital in overcoming any potential problems in terms of confidentiality and anonymity that could have potentially arisen during the study.

## **4.4 Capturing employee preferences and other data**

One of the most successful aspects of the use of QUALISEM-PEOPLE proved to be the stage of the method that involved employees rating their own

preferences for qualifications and new competences alongside actual and target ratings. One benefit of this approach was that employees felt that the resulting skills gap analysis was not something that was being imposed upon them by managers within the company. Employees correspondingly felt a large degree of ownership of the outcomes derived from the method. This could potentially prove beneficial in the later implementation of new competences and training programmes within the company.

## **5. SUMMARY AND OUTSTANDING CHALLENGES**

At present, QUALISEM-PEOPLE is a method that helps to identify skills and qualification gaps on the basis of an assessment of the actual, target and preferred competence-based needs of employees. The method represents one way in which to systematically analyse and evaluate these types of requirements and provide companies with guidance. In particular, it can be used as the basis for making decisions regarding the form, content and type of training programmes (e.g., e-learning, blended learning, classroom instruction). The method helps to fill a gap in current practice where the use of systematic approaches to the assessment of skill and qualification needs in the context of e-learning is often piecemeal and incomplete. This is particularly the case in industries such as software development where new roles and competences emerge over very short time periods. An additional strength is that it is relatively straightforward to use and actively involves employees in the process of needs assessment.

The case study we described illustrated a number of important lessons that can be learnt from the use of methods such as QUALISEM-PEOPLE. In particular we would highlight the importance of integration with other HRM activities within companies and the need to view skills assessment as a continuous and iterative process rather than a discrete output. A second lesson is that employees should be involved as much as possible in the change process as this can provide a number of benefits.

There remain a number of outstanding challenges that go beyond the scope of the present work we have described. In particular we would point to the need to develop systems, methods and tools that provide guidance in selecting different types of learning (e.g., the choice of blended vs. traditional classroom learning) and assessing their suitability in the light of the results of needs analyses, the personal preferences of the individual learner, as well as other criteria which may be relevant (e.g., type of instructional material). We believe that QUALISEM-PEOPLE is only a

small step towards such a goal but it also provides a good basis for improving future generations of e-learning.

## REFERENCES

- Barron, T. (2000), A Smarter Frankenstein: The Merging of E-Learning and Knowledge Management. *Learning Circuits*, 1(8) [online]. Available [http://www.astd.org/ASTD/Resources/dyor/article\\_archives.htm](http://www.astd.org/ASTD/Resources/dyor/article_archives.htm)
- Darby, J. (2002). Beyond the Horseless Carriage: 2nd and 3rd Generation Models for e-Learning. [PowerPoint presentation]: University of Waterloo, CA: The centre for teaching and learning through technology. Available <http://lt3.uwaterloo.ca/colloquium/images/Waterloo.PPT>
- Haas, A. (2001) *Handbuch Qualifizierungsmodell*. Internal Report, Fraunhofer IESE. Available <http://www.iese.fhg.de/ESF-Baukasten/BSK/Quali-Modell>.
- Kirschner, P.A. & Valcke, M.M.A. (1993). *From supply driven to demand driven education: New conceptions and the role of information technology therein*. Paper presented at the HUSITA-3 Conference, Maastricht, June 16-18, 1993.
- Knight, J. (2002), *Making sense of e-learning in a confused market*. Editorial. [online]. Available <http://www.e-learningcentre.co.uk/eclipse/articles/makingsense.htm>.
- Van Petegem, W.E.A. (2000), Virtual Business Teams: A new approach in engineering education. In J. Michel (Ed.), *The Many Facets of International Education of Engineers*, Rotterdam: Balkema.
- Wilbers, K. (2002), Didaktik des E-Learning im Spannungsfeld von Wissensmanagement, elektronischem Management der Humanressourcen und E-/M-Commerce. In G. Cramer, and K. Kiepe (Eds), *Jahrbuch Ausbildungspraxis Erfolgreiches Ausbildungsmanagement*. Köln: DWD-Verlag.

## BIOGRAPHY

Dr Dieuwke de Haan has a background in educational innovation and technology, with a focus upon educational assessment and testing in higher distance education. As a scientist at Fraunhofer IESE, her main interest is in research and development of models for quality assurance of (in)formal learning and in assessment of competence needs, all within the area of software engineering. Dr Patrick Waterson is a scientist at Fraunhofer IESE. His background is in work psychology and human-computer interaction. His current research interests focus upon workplace learning and the integration of concepts from work psychology into software engineering training and education. Sonja Trapp holds University degrees in Linguistics and Adult Education. She joined Fraunhofer IESE in 2001 where she has been working in research and industrial projects on e-learning and ICT skill profiling.

Dr Dietmar Pfahl is heading the Certifiable Education and Training (CET) department of the Fraunhofer Institute for Experimental Software Engineering(IESE), Kaiserslautern, Germany. His past and current research interests include software process improvement, change management, simulation-based learning, collaborative learning, and the integration of e-learning with knowledge management.

# COGNITION, CULTURE AND EFFECTIVE E-PRAXIS GUIDING PRINCIPLES

## *Theoretical Roots for e-culture*

Mohan R. Gurubatham

*International Business School, University Technology, Malaysia*

**Abstract:** Cultural approaches to technology enablement must include type of content and type of medium with type of culture. Refining beyond shared interpretations of content by culture we need to examine cognitive mechanisms that may underpin the cultural modes of assimilation of e-learning and enlivening knowledge management. The paper compares western and Asian (Malaysian) contexts for learning. Design implications are alluded to.

**Keywords:** Power distance, high-context, low-context, cognitive, schema, collectivism.

## 1. POWER DISTANCE AND HIERARCHY

In his *protean* exposition of ‘power distance’, Hofstede (1980) explains that ‘low power’ cultures such as the United States, Canada, the United Kingdom, Australia and Israel are depicted as ‘looking for equality’—there is a markedly pragmatic approach to status where organizational hierarchy is relatively unimportant. These broadly western nations may be characterized as having ‘low power distance’, albeit in varying degrees.

East-Asian nations, in contrast, have higher power distance (Hofstede, 1991a, 1991b). High power distance is the ‘cultural programming’ that drives thinking and behaviour. In such societies there is a respect for hierarchy that is manifest in attending to, and in addressing, titles and salutations, and in deferring judgements to (and not openly contradicting) superiors. Deference to authority and acquiescence are prevalent in high power distance cultures.

## 2. CONTEXT AND RELATIONSHIPS

Communication as a *milieu* in Japan, China and in Mediterranean cultures invokes the seminal work of Edward Hall (1976), who coined the concept of high context (HC) cultures versus low context (LC) cultures. In hard empirical terms, less is known about Malaysia and South East Asia in Hall's continuum. In HC cultures, communication processes are non-verbal, non-linear and '*analogue*'. Analogue representations are patterned, relational information that involve a compromise between the abstract and the concrete codes involved in mental processing. They invoke psychological sets. Further, analogue processing is quick. Relationships in HC cultures are also 'warm' (Berry et. al, 1992, p.42) and in the field of business, relationships are understood to be important. Time spent on relationship building may be prioritised over tasks, and it is common for punctuality to be traded off towards relationship building.

However, there are differences amongst Asian cultures with some being perceived as 'warmer' than others. From descriptions, and through long exposure to Asian cultures, experience suggests that East Asian and Indian cultures are high context. As such, HC appears to be an artefact of pre-industrial societies. These societies have extended families and they emphasize relationships wherein time is taken to build and nurture relationships. What is 'said' in high context cultures, involves not just speech or writing, but also the nuances of feeling, spatial information and relationships.

High context cultures are also said to be *polychronic*. The defining feature is accepting a simultaneity of events without closure. Time here is viewed flexibly; enactments may be a heuristic completion of communication and tasks are considered more important than rigidly following a schedule. Polychronic time is said to be cyclical and multi-track, and it is perfectly acceptable in high context cultures to carry on multiple tasks and to engage in more than one conversation simultaneously. Strangely, people appear less hurried and seem to have less stress in HC cultures. There is a higher propensity to appear accommodating, and information flows through fluid links in a broad network of interpersonal contacts. Not reporting sensitive and potentially offensive information in the mass media is considered good manners in the social context of nation building. Mass media are integrated into the wider social context and government agenda, which in this case desires to maintain public morale. What is not said is as communicative as what is said, if not more subtle and powerful. Similarly, mediated learning captures this same ethos even in areas as functional as in e-learning or knowledge management in organizations.

On the other hand, LC cultures carry a trait dubbed *monochronicity* i.e., time is perceived as compartmentalized rigidly so as to encapsulate schedules. There is a sequential unfolding of task and communications which are dealt with in a linear mode. Customers are accordingly served one at a time, one after the other. Schedules and timetables are tenaciously adhered to so that deadlines are met; planning favours algorithms. LC cultures emphasize tasks and they compartmentalize relationships which mandate a tight agenda in the acquisition and use of information from various sources. Relationships are organized around tasks.

### 3. COGNITIVE BASES OF CONTEXT

Analogue representations appear to be more rapidly processed through analogue codes and are schema-driven, that is, they involve top-down processing of well-learned mental templates. This may be understood when we quickly glance at an analogue watch to see the time—obtaining this merely from the shapes of the hands and their spatial relationship to the rest of the watch face. In high context cultures, a less direct communication of process or task management through non-verbal communication is common and becomes automated over time as unconscious competencies that appear informal and heuristic. Largely, they are not resonant in working memory (short term memory). On the face of it much of this is passed off as ‘intuitive’ processing, but they belie a repertoire of intricate and systematic skills drawn from a rich database of procedural (concrete scripts) and declarative (abstract) or factual information in long term cultural memory.

Cultural memory systems include the organization of prior knowledge into categories. These categories are largely natural (Wittgenstein, 1953; Rosch, 1975) and may be the result of a process that is ‘wired in’ to abstract *prototypes* from an ever-changing universe of stimuli and data. Analogue representations are prototypes; prototypes are schemas that evolve through learning by abstracting ‘*unification*’ rules for organizing structural sets from the world of diversity i.e., changing environmental stimuli. The prototype abstraction process is innate, not the representations, so that greater economies in neurological storage capacity are afforded. The course of socialization in the culture then adds data to embellish these schemas.

Schemas are structural prototypes that provide rudimentary templates that skew the perceptions of incoming stimuli during encoding; they store the data accordingly within scaffolds and they drive a response bias. Therefore both the inherent structural form of the schema and the learned data reside in long-term memory. Long-term memory involves parallel processing and random access and is largely unconscious. In the evolution of



cultural expertise, skills are learned through distributed practice (paced with intervals) over time, with enough mass practice (rehearsal) within each interval to enter long term memory as automated bundles.

In the real ‘messy’ World, the retrieval and application of these skills would appear to be spontaneous. Retrieval cues exist in both digital and analogue formats. Digital codes require more conscious attention such as when we read digital watches, tenaciously follow the syntax and decoding of the words in legal contracts, or examine the specifications of business contracts. Conscious attention is the ‘transparency’ that working memory provides but it affords a severely limited serial processing capacity; it slows us down. Analogue cues map more directly into analogue representations in long term memory and involve a less conscious cognitive effort.

However, in one interesting study in cognitive psychology, it was found that even with meaningful one-word semantic cues (nouns as verbal stimuli), matching information was retrieved faster from long term memory (Freedman & Loftus, 1971) than with cues with little meaning. Thus while not actually analogue in representation, these verbal analogues afford practically speaking, economical processes. As one-word cues are meaning-rich signals they activate ‘bundles’ of matching information in long term memory. The process occurs as analogue codes where category size did not matter. In other words parallel processing is implicated whether categories in long term memory were large or small in terms of the number of component elements.

The relatively longer history of Asian civilizations directly raises the probability of larger ‘bundles’ of social schema being formed and being ‘tripped’ through parallel processing. Several thousands of years of structured civilization with little need to challenge the natural order of things allows for massive ‘bundling’. Stereotyping behaviours are examples of social schemas that break down when the analogue parallel processing of matching is pushed to the limits. There is a need to *unbundle* when critical environmental features do not match prior knowledge in long-term cultural memory. You can unbundle easily in working memory but not when invoking parallel processing from long term memory. Transparency is simply not inherent in parallel processing, yet perception here is quick (Gick & Holyoak, 1987; Larkin et. al., 1988).

Unbundling automatic routines is difficult. Similarly much of relationship-building—the informal supervision in process checks that are often heuristic—may be seen as the result of this automatization of cultural scripts in the course of cultural evolution. Asian culture and history is ancient and it characteristically integrates self with society, the environment and the natural order of the cosmos. Just as in the performance of expert car driving where an operator appears to navigate through an environment

automatically, automatic inter-personal analogue processes dominate high context interactions somewhat naturally given their longer history of navigating through relationships with the cosmos. Cultural values drive levels of pertinence to assign environmental features their due attention. If perceived as not critical, they will be attended to by the process of assimilation. This is relatively easy with no need to uncouple from automaticity. Working memory entertains the differences in the task or relationship environment. If perceived as highly critical, then there is a need to unbundle or accommodate. This is of course stressful, and this is where intercultural dissonance arises.

#### **4. TRANSPARENCY AND LOW CONTEXT**

In LC cultures, communication involves digital or propositional codes (verbalizations). The emphasis here is on the precision required, which demands constant attention to details. LC societies are an artefact of the industrial revolution where rural to urban drifts of large populations had spawned discrete and smaller family units such as nucleated families.

In LC cultures there is less formal emphasis in LC societies on building relationships; transparency is cognitive, and is part and parcel of a consciously managed process. Every layer of the process, including procedures, must be structured into steps which are clearly distinct, albeit linked. From a systems viewpoint, this provides control with feedback and adaptation. And for some—the LC adherents—it offers a conscious formal approach to management in a chaotic world, which is how they perceive the HC world with its attendant lack of transparency.

Documentation and standards are overtly and explicitly communicated in the LC world. Much of this orientation is manifested in quality management systems, performance appraisals, and competencies that break up overall expertise into a hierarchy of documented components. Appointments that specify times to the minute are expected to be honoured, and punctuality is a major factor in the evaluation of some one who is late or tardy.

Similarly, because of the relatively strong emphases on verbal communication, in the LC world contracts are written and are specific. They delineate the specifications of deliverables, products, roles and time frames. Market leads have to be formally assessed with the appropriate documentation to prevent wastage of time or other resources in promotional efforts. Even contingencies are covered by legal clauses. There is a relentless thrust towards transparency, and a managed task orientation.

## **5. COLLECTIVISM**

Hofstede (1980) established 'collectivism' as a descriptor of cultures that are either individualistic or collectivist. Malaysia, like other east Asian nations, has a low individualism score. It is more collectivist in comparison to western industrialized nations which are largely individualist. Collectivist cultures place society over self, where group thinking dominates. Face-saving is also prevalent when confrontation and contradiction are to be avoided. Taken together in HC interactions, high collectivist and high power distance cultures celebrate ritual and respect seniority. They also adhere to the use of titles and salutations, emphasize relationships, and express loyalty. There is a popular consensus that high context cultures also integrate work, spiritual, and personal spheres of their lives.

However there is a need to be guarded in defining the features of this interaction, as the exact sociometric relationship of both Hall's dimension of context and Hofstede's dimension of collectivism remain untested and unresearched.

## **6. THE GLOBALISATION OF LEARNING: IMPLICATIONS**

High context, high power distance and collectivist cultures, while paternalistic, are perceived by some as benign dictatorships. Sometimes exceptions to the stipulated trait of formality in power distance occur. This relative informality appears to be more prevalent in Asian countries of rapid economic development and have more to do with high context and its characteristic of warmth and natural social coherence. To be sure, these models, whether Hofstede's or Hall's, maintain variations of culture as slowly changing antecedents.

But culture's consequences are also evolving. Imagine that what you are witnessing in Malaysia is a time compression of all of the 300 years of the industrial revolution into the 30 years of recent development. Then add to this the demands of the knowledge worker era in the last 3 years and the competitive drivers of the globalisation of best practices, and the collapsing of the traditional structures' styles of governance enabled by the free flow of information.

These arguably represent a lot of shocks to the system. Within this demand for rapid adaptation the easiest aspect to change in power distance terms would be the formality of protocol, the most difficult to relinquish would be control. (Gurubatham, 2001)

## 7. E-LEARNING IMPLICATIONS FOR ASIAN CULTURES

The following are implications for implementing e-learning solutions in Asian cultures that arise from the discussions in this paper.

1. Power distance shapes access to information structures such that higher power distance will naturally prefer a relatively higher degree of structure than lower power distance. Control and access issues may not be discounted.
2. Mental models or schema may favour hierarchical relations.
3. Emphasis on authority to favour official insignia, logos, and content certification. Formal status effects are active that may inhibit, for example, a professor's acceptance in a chat room.
4. In high context and collectivist e-learning, and knowledge management, courtesy, personal acknowledgment rituals and relationships should be infused into the content to counterbalance the formality of power distance.
5. It appears that some of the elements of polychronicity may be exploited and synergise over time to accommodate a higher degree of task orientation for multitasking such as in call centres, utilizing on-line performance support while attending to customers.
6. Advance organizers or concept maps are analogue cues. They can exploit visual or metaphorical (proverbs), or even culturally endeared phrases to prime high context learners with navigation aids for complex content.
7. Asian cultures tend also to be risk-averse or are high in uncertainty avoidance (Hofstede,1991). Learner control may be initially inhibited and requires active coaching in the initial stages of e-learning. This inhibition may also prevent populating databases in knowledge management. However this tendency can be actively counterbalanced by enlivening the high context of teamwork, sharing and interpreting information.

## REFERENCES

- Berry, J. W., Poortinga, Y. H., Segall, M. H., & Dasen, P. R. (1992). *Cross-cultural Psychology: research and applications*. Cambridge: Cambridge University Press.
- Freedman, J. L., & Loftus, E. F. (1971). Retrieval of words from long-term memory. *Journal of Verbal Learning and Verbal Behavior*, 10, 107-115.
- Gick, M. L., & Holyoak, K. J. (1987). The Cognitive Basis of Knowledge Transfer. In S. M. Cormier & J. D. Hagman (Eds.), *Transfer of Learning: Contemporary Research and Applications* (pp. 9-47). San Diego: Academic Press.

- Gurubatham, M. R. (2001). Maximising Human Intelligence Deployment. In J. B. Kidd, X. Li & F. Richter (Eds.), *East Asia—The 6th Generation Project*. London: Palgrave.
- Hofstede, G. (1980). *Culture's Consequences: International Differences in Work-related values*. Beverly Hills: Sage
- Hofstede, G. (1991a). Management in a multicultural society. *Malaysian Management Review* 26(1), 3-12.
- Hofstede, G. (1991b). *Cultures and Organizations: software of the mind*. London: McGraw-Hill.
- Hall, E. T. (1976). *Beyond Culture*. New York: Anchor Books.
- Rosch, E. (1975). Cognitive representations of semantic categories. *Journal of Experimental Psychology: General*, 104, 192-253.
- Wittgenstein, L. (1953). *Philosophical investigations*. New York: Macmillan.

## BIOGRAPHY

Mohan Raj Gurubatham is interested in the cultural and cognitive bases of learning in advanced Asian countries, especially with pressures of globalisation in the knowledge economy. He is currently integrating the role of intangible factors in ICT within an organic 'eco-field' framework.

# THE TEACHER: FROM A RESPONSIBLE STUDENT'S POINT-OF-VIEW

Marijke Hezemans and Magda Ritzen

*Hogeschool van Utrecht, University for Professional Development and Applied Science:  
CETIS, Expert Centre for Educational Innovation and Training*

**Abstract:** Dutch universities of professional education are working with institutions in the field to develop programmes that are intended students to develop into starting professionals. The implementation of these new programmes means adopting a new methodology and this assumes that the teacher learns. This paper will show by means of a case description how a teacher, supported by ICT, can realise a personal learning process in such as way as to effectively guide and supervise an analogous learning process for the student. In this case the teacher and the student are central. The professional field provides the tools for practising this competence management.

**Key words:** learning models, cognition, collaborative learning

## 1. INTRODUCTION

Dutch universities of professional education are working in co-operation with institutions in the field to develop and implement programmes that are intended to give students optimum preparation for the reality and dynamics of professional practice. These new programmes aim to provide learning environments that enable students to develop into starting professionals: they develop their competence and professional expertise in learning environments of varying complexity.

This paper will show, by means of a case description, how a teacher supported by ICT can realise a personal learning process in such as way as to effectively guide and supervise an analogous learning process for the student. In this case the teacher and the student are central. The professional

field provides the tools for practising this competence management. The case description is taken from the project ‘Competence development & portfolio’: a project which is carried out in the part-time economics programmes at the Utrecht University of Professional Education (Hogeschool van Utrecht).

The project aims to maximise the part-time students’ competence development (learning) with the help of a digital learning environment (e-folio environment) developed by teachers who are coached by two educational staff members attached to the project. In this learning environment part-time students learn among other things to reflect on their work experience by means of a personal development plan and the competence profile of the programme. As well as self-reflection, which on the student’s initiative is coached by the teacher, reflection also takes place in peer groups.

During the project a digital portfolio (e-folio) is developed to support and make visible competence development. The e-folio is a protected area in the e-folio environment that is only accessible to the owner of the e-folio. The owner can make (parts of) the e-folio accessible to others. The e-folio has a dual function within the learning environment:

1. As an instrument for supporting and making explicit development and reflection (Kösters & Ritzen, 2001); and
2. As a showcase on the basis of which assessment can take place (Schulman, 1998).

The e-folio supports the students in carrying out their personal development plans, in which learning outcomes are defined in relation to the competence profile of the programme. Accompanying assignments, and a coaching and assessment protocol are also developed, so that teaching and assessment are also related to the competence profile of the programme.

## **2. THE E-FOLIO TEACHER: COMPETENCE DEVELOPMENT**

The ‘Learning environments and responsibility’ model (Hezemans & Ritzen, 2002) was created to support the development and realisation of learning environments as mentioned above. This model sets out the specific contribution, defined in terms of responsibilities, of each of the three parties (students, teachers and the professional field) who are involved in competence-based learning environments which enable students to develop into starting professionals. The model aims to give an overview of the most important principles and moments of choice for the development of learning environments. The model emphasizes that within every type of learning

environment the teacher is responsible for defining assignments for the students. To create the optimum learning environment all parties involved need to share responsibility. The 'Learning environments and responsibility' model implies that the student, the teacher and the professional (representative from the field) learn and develop. Hence the introduction of new competence-based programmes means adopting a new methodology and this assumes that the teacher also develops competencies and professional expertise in relation to the programme (Witteaman, 2001).

## 2.1 Learning programme for the e-folio teacher

Analogous to the part-time students' learning process a programme was set up within the project in co-operation with the Virtual Learning Centre (VLC) of the Utrecht University of Professional Education to support the teachers' competence development in the e-folio environment. The teachers can only take part in the 'e-folio teacher' learning programme when they are actually teaching students who are working with an e-folio. The aim of the course is two-fold:

1. To train competent e-folio teachers, both in relation to guiding the students' development as well as ICT-skills; and
2. To act as an example to students and colleagues.

A competence profile for an 'e-folio teacher' was developed, in which competencies relevant for the effective teaching of students working with an e-folio are defined (Hezemans & Kinkhorst, 2002). This teaching method is based on the principle of 'learning to learn'. The following competencies were included in the profile:

*Table 1. Competencies of an 'e-folio teacher*

<i>Competency</i>	<i>Description</i>
<b>Coaching</b>	The ability to stimulate, direct and accelerate students' development.
<b>Problem analysis and judgement</b>	The ability to analyse problem situations and make an adequate estimate of their importance for the student's development.
<b>Integrity</b>	The ability to be open and honest, and to act according to the values, norms and responsibilities belonging to the role of teacher.
<b>Ability to learn</b>	The ability to actively acquire knowledge, skills and attitude, to continue to develop one's own practice and to continue to develop products.

Starting from their personal learning needs (personal competence profile), the e-folio teachers each made a personal development plan. The



development plan shows the way in which the above competencies will be developed (learning activities) and which forms of support (e.g. training or peer assisted learning) are needed. The teachers collect their evidence in their digital portfolio (e-folio) by means of which they can demonstrate that they have completed learning activities and thus have developed the above competencies.

## **2.2 Assessment**

The course is rounded off with an e-folio assessment (Hofman & Kinkhorst, 2002). In the e-folio assessment two assessors independently assess the evidence presented in relation to the competence profile of an 'e-folio teacher'. When teachers judge that they are ready for the e-folio assessment, they apply for the assessment by submitting the e-folio to the assessors. The first and second assessor judge the e-folio independently of each other according to the following criteria:

1. The competencies of an e-folio teacher as operationalised in the competence profile of an 'e-folio teacher': Does the teacher possess a behavioural repertoire which sufficiently covers the competence profile?
2. Ability to learn: Are teachers able to learn through working, to recognise and use their qualities, and to recognise and compensate for their limitations?

On the basis of the following elements: relevance (the material is relevant to the competence involved); concreteness (the evidence is sufficiently concrete and specific); depth (of reflection); and coherence (links within evidence are made explicit). The assessment is discussed with the teacher during an e-folio assessment interview.

## **3. E-FOLIO TEACHERS LEARNING TOGETHER**

### **3.1 Community of e-folio teachers**

The e-folio teachers expressed the need to exchange ideas and share experience in relation to the supervision of students and their own learning. The teachers are aware of the opportunities offered by educational innovation for themselves and their students, and are motivated to learn. To support this learning process a digital environment was created in consultation with the teachers and agreements were also made about discussions in person.

In fact this has led to the creation of a 'Community of Practice'. The most important characteristics of a Community of Practice are (McDermott, 2001, Wenger & Snyder, 2000):

1. group size of 3–500;
2. oriented towards sharing information and experience, and learning together;
3. focussed on a specific domain;
4. based on problem or questions;
5. within or between organisations;
6. not directed towards primary process.

These characteristics apply to the 'community of e-folio teachers' described above. There is a group of people who are working together to exchange and develop knowledge; the community exists thanks to the participants; there is role differentiation; and the community members decide how long and about what they will continue to interact with each other (McDermott, 1999, Römgens, 2001).

The community remains in existence as long as it fulfils a need of its members. The functioning of the community is fed by the experience (practice) which the teachers gain through coaching students in practice. The community aims to learn from this and to arrive at new forms of 'practice': the community is therefore not directly concerned with the primary process.

Communities of Practice demonstrate similarities with peer-assisted learning groups. The difference, however, is that in a Community of Practice members are aiming towards a common product, while members of a peer-assisted learning group are mainly learning as individuals (Simons, 2001).

### **3.2 Working methods in the community of e-folio teachers**

The teachers come together regularly and are supported in this by two educational staff members from the 'Competence development & portfolio' project. The staff members (or moderator and facilitator) have expertise in the area and ensure that there is a room for discussion, an agenda (based among other things on the members' contributions), a digital environment and a focus to the discussions. There is no further differentiation of roles.

The community is still closed: only e-folio teachers have access. The reason for this is the vulnerability of working on innovation; the security of learning and working in a trusted group is guaranteed. However for effective knowledge development it is necessary to 'open the shutters', to let the outside world in and to learn from this (van Weert, 2002). Therefore the idea is to eventually open up the community, so that others who are interested can also make a contribution. The community is then made up of experts who

are involved on the basis of their expertise in various projects and who need each other to really progress with their knowledge development. It is important that the organisation shows that they set store by these developments, by for example showing concern for the members of the community by means of coaching and making time available. Above all a recommendation is given which is true for all communities: 'Be patient'; getting a knowledge development process off the ground in a Community of Practice takes time (McDermott, 1999).

The alternation of physical and virtual is important: in the meetings teachers show each other their approach and discuss problems. Subjects for discussion are for example:

- a teacher thinks it is necessary to direct the students' development according to a pre-arranged time schedule under the motto 'deadlines motivate students';
- another teacher tries to motivate students by getting them to act as sparring partners for each other;
- yet another teacher supervises students digitally and the students hardly have any (physical) contact with each other either.

The question in relation to each of the items above is: What consequences does this have for our teaching practice and do we find this desirable? The experience of working with various methods are exchanged and experiments are carried out on the basis of this. In this way a shared vision is established of what is essential in regard to teaching students and how this relates to one's own learning activities.

The concrete knowledge product which is aimed for consists of guidelines on the basis of which the teacher can decide on and carry out the practice of e-folio teaching. Models of good practice illustrate this. The digital environment is intended for noting appointments and evaluation questions for students to exchange with each other, carrying out short discussions (more extensive discussions take place physically), recording proposals in regard to a teaching methodology and giving examples of good practice. Meetings are also prepared through the digital environment.

#### **4. CONCLUSION: THE TEACHER, A PROFESSIONAL ROLE MODEL**

In the learning environment described above teachers are actively working to develop competencies and professional expertise; they are learning on-the-job. Working as a professional is in fact characterised by three phases (Simons, 2001):

1. relate: working with knowledge, learning from working on and making explicit the implicit results of learning;
2. create: extending knowledge by, for example, carrying out research, explicit learning;
3. donate: putting into practice, presenting, promoting one's own knowledge. This also includes the development of the profession. The table below shows how the e-folio teachers realize the work phases defined above.

Table 2. The work phases of a learning e-folio teacher

Work phase of professional	Concretisation in e-folio teacher's learning
<b>Relate</b> learning from working	Students' and teachers' learning runs parallel; teachers can only take part in the 'e-folio teacher' learning programme when they are actually teaching students who are working with an e-folio. The teacher is asked to carry out self-assessments and to reflect on these by means of reflection assignments. The <b>teacher e-folio</b> functions as a support in making the results of learning explicit or visible. The e-folio environment includes for example self-assessment instruments.
<b>Create</b> explicit learning	As part of the learning programme the teacher is assigned to formulate learning outcomes in relation to the competence profile of an 'e-folio teacher'. These outcomes, including learning activities and desired support, are recorded in a <b>personal development plan</b> .
<b>Donate</b> developing the profession	During the programme (and possibly after) the teacher is stimulated to participate actively in the <b>community</b> of e-folio teachers. The aim of this community is to develop instruments and aids (guidelines) which will optimise the teaching practice of an e-folio teacher.

The preceding has shown how teachers as professionals can give form to their own learning process supported by ICT: they create a portfolio, make a personal development plan and participate in a Community of Practice. In the process of teaching, students use the same tools; they too after all are being trained as starting professionals. Through guiding students by means of the same sort of learning assignments as they themselves are carrying out, teachers can act as role models; they show students how they themselves learn as professionals.

## REFERENCES

- Bruining, T., & Haffmans, J. (2001). Werken aan communities of learning en communities of practice. Verbeteren van leren werken. Interview met R.J. Simons. *Opleiding & Ontwikkeling, 11*, 7-10.
- Hezemans, M., & Kinkhorst, G. (2002). *Competentieprofiel e-folio begeleider*. Utrecht: Hogeschool van Utrecht/Virtueel Opleidingscentrum.
- Hezemans, M., & Ritzen, M. (2002). Learning environments and responsibility. In: D. Passey & M. Kendall (Eds.), *TeLE-LEARNING: The Challenge for the Third Millennium*. Massachusetts: Kluwer Academic Publishers.
- Hofman, K. & Kinkhorst, G. (2002). *Handleiding Portfolio en portfolio-assessment*. Utrecht: Hogeschool van Utrecht/Virtueel Opleidingscentrum.
- Kösters, J. & Ritzen, M. (2001). *Combining Different Aims in a Portfolio System: a Web-based Portfolio and the Various Ways in which it can serve the Student*. Retrieved January 16, 2003, from <http://www.cetis.hvu.nl>
- McDermott, R. (1999). *Learning across teams, how to build communities of practice in team organizations*. Retrieved January 14, 2003, from: <http://www.km-review.com>
- McDermott, R. (2001). *Knowing in Community: 10 Critical success Factors in Building communities of Practice*. Retrieved January 14 2003, from <http://www.co-1-1.com/knowledge-garden/cop/>
- Römgens, B. (2001). *Inleidende visie Community of Practice*. Retrieved January 14, 2003, from <http://www.24x7edu.net>
- Schulman, L. (1998). Teacher portfolios: a theoretical activity. In N. Lyons (Ed.), *With portfolio in hand validating the new teacher professionalism*. New York: Teachers College Press.
- Simons, P. R. J., & Ruijters, M. (2001). *Learning professionals: towards an integrated model*. Paper presented at the conference of the European Association for Research on Learning and Instruction, Fribourg, Switzerland.
- Weert, van T. J. (2003). *New Education: de achterkant van het Digitale Wonderland*. Utrecht: Hogeschool van Utrecht.
- Wenger, E. C. & Snyder, W. (2000). Communities of Practice: the Organizational Frontier. *Harvard Business Review*, January-February, 139-145.
- Wenger, E. C. (2001). *Supporting communities of practice, a survey of community-oriented technologies*, version 1.3. Retrieved January 15, 2003, from <http://www.ewenger.com/tech>
- Witteveen, H. (2001). Oude didactiek past niet in nieuwe onderwijsvisies. *Thema, Tijdschrift voor Hoger Onderwijs en Management, 1*, 17-25.

## BIOGRAPHY

Marijke Hezemans, having gained a teaching diploma in Mathematics and Chemistry as well as a degree in Education, now works as an educational advisor and developer. She supervises both the content of innovation processes: the development of competence-based curriculum elements as well as their organisation: the implementation of competence-based programmes. Magda Ritzen is an educational psychologist and has been working for a number of years on educational innovation and the role played in this by ICT. She works as an educational advisor and project leader on redesigning the curriculum. She is involved in projects in the areas of learning in a real-life setting and portfolio as well as communities of practice.

# THE VIRTUAL OFFICE

## *A framework for the virtual office*

John Holmström and Veli-Jukka Leppänen

*Tampere University of Technology*

**Abstract:** In this paper, a Virtual Office is defined as one in which working and learning methods are enabled by information technology facilities, systems and services. Work in a Virtual Office is based on HyperPoint networks. A HyperPoint can be an information system, the Internet, a human being, another HyperPoint Network or generally a point that contains knowledge. In the future, most work will be done in such knowledge intensive HyperPoint Networks. HyperPoints contain tacit as well as explicit knowledge. The strength of a HyperPoint Network depends on how well it can utilise tacit knowledge. The authors also present an idea of multi-sensitive knowledge base. The results of virtual office research and earlier research are being put into practice in a regional case — Loimaa eWork.

**Key words:** Knowledge management, information handling, tacit knowledge, on-the-job training

## 1. INTRODUCTION

This paper describes the authors' theoretical research and its application in practice. Their research focuses on new ways of working and on formulating the concept of the Virtual Office. They first introduce their theoretical framework and then describe its application to the Loimaa eWork case — a training and development project that includes consulting the personnel in the enterprises and communities in the Loimaa region in the South West of Finland.

Knowledge intensive work can be described by a framework that consists of different simultaneous processes and techniques that are accessed through multi-view user interfaces. Working in a virtual office is network-based and can be defined as comprising a HyperPoint network because a HyperPoint

can be a human being, an information system, the Internet, another HyperPoint Network or (generally) a point which contains knowledge. In a HyperPoint network, human knowledge and actions are simply another HyperPoint.

The authors also present the idea of a multi-sensitive knowledge base. The gathering of tacit knowledge can be speeded up by an active query system to a HyperPoint Network. By the means of the query system, the existing explicit and tacit knowledge gradually forms a multi-sensitive knowledge base. The results of virtual office research and earlier researches are being put into practice in a regional Loimaa eWork case.

## 2. THE VIRTUAL OFFICE

In this paper the term ‘Virtual Office’ refers to the working and learning methods and processes that information technologies make possible. In addition, the concept includes the facilities, systems and services that are based on introducing an office-like solution in the workplace. The conditions for working consist of virtual, social and physical working spaces, of organising the work, and of technical systems. The working spaces encompass both individual and group work such as knowledge production and thinking. By networking and increasing connections, the emphasis of work will move from traditional physical working spaces towards virtual and larger social working spaces. (Pekkola, 2002). *‘The doubts that virtual environments gather tacit knowledge, or that it is difficult to explicate the knowledge, are exaggerated. The facts which make it possible to produce tacit knowledge and visible mutual interaction are clearly linked to virtual environments and combining functions in different environments.’* (Pekkola, 2002). The operations of a virtual office are based on a mutual agreement about how the virtual office should be used. The suitability of a virtual office to support a group depends on how well the working methods of each member suit the common agreed mode of working (Kuusinen, 2001). Research has shown that there are many factors and complex interactions which affect the nature of a virtual office and its suitability for a particular role. For example, Vartiainen and Hakonen (2002) employ Actor-Network theory to define virtuality through four dimensions: *‘The relationships of any actors, be they individuals, dyads, teams, projects, organizations or networks can be characterized by four dimensions:*

- space (same place vs. different, dispersed place; fixed vs. mobile);
- time (same, synchronous vs. different, asynchronous; permanent vs. temporary);
- mode of interaction (face-to-face vs. mediated);

- diversity of actors (similar vs. different);

The aspects of the virtual office dealt with in this paper focus on the nature and role of knowledge as a key element of the virtual office based on their experience with virtual offices in the USIX project 'The Value Chains in Distance Technology for Small Businesses and Education', which was financed by TEKES in 1998-2002 in Tampere University of Technology, Pori.

## 2.1 A framework of knowledge intensive work

The present systems consist of different applications, all of which have individual user interfaces. The studies on usability have shown that user friendliness is very important. The problems are due to the fact that applications and systems are often closed and their user interfaces are planned taking into account only the technology, not the user. At present the problem of the whole framework is that even though we have numerous solutions to each part and process, the solutions are fragmented and they do not communicate with each other. Though a huge number of studies have been carried out concerning each part, the authors have not found a holistic approach as in Figure 1 — the framework of virtual work.

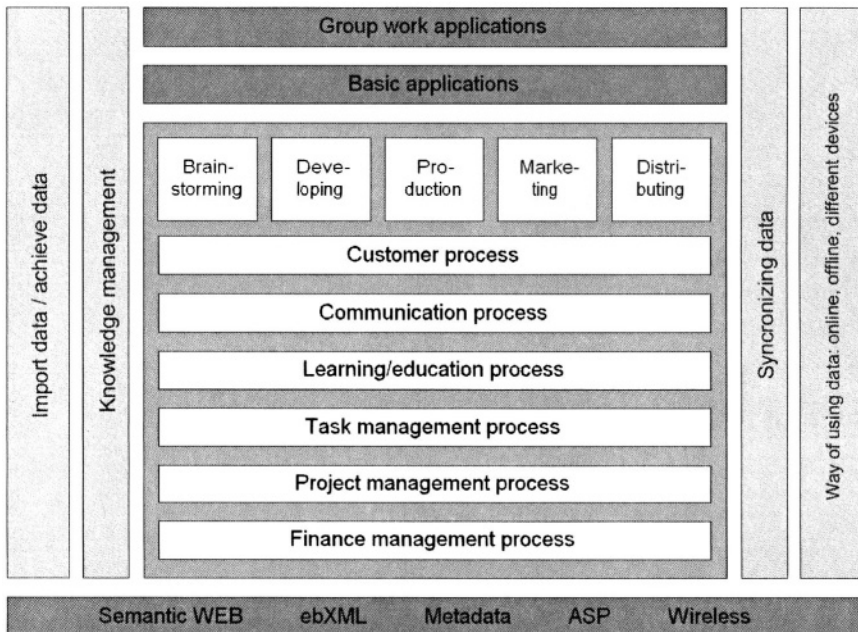

Figure 1. A framework of virtual work. (Holmström & Leppänen, 2002)



Figure 1 illustrates the author's framework of virtual work. In the picture, the value-chain in the middle is the value-chain of content-producing information technology. It can be replaced with the appropriate value chain of any branch in question.

## **2.2 Multi-view user interfaces**

The aim of a multi-view interface is to combine the needs, knowledge, roles and tasks of each user into a single user interface. While the usable applications communicate with each other, data transfer will be kept secret both between applications and between the user and the system. Virtual working makes both remote working and split applications possible. The main problem for the user is to gather the knowledge that is needed, in an appropriate form, by using background systems which utilise metadata securely. This means that the knowledge which the user needs has to be collected from the sub-applications which function independently.

## **2.3 Hyperpoint networks**

A traditional office workplace has all requisite knowledge in one physical place; a virtual office must provide the same accessibility to knowledge, both explicit and tacit. Working in a virtual office means working in the place where you are when you decide to work. This is possible if the knowledge needed for your work can accompany you. When connected to the Internet one can easily reach remote information sources. However, nowadays you cannot always be online, which makes offline services very important as well. Working in a virtual office is network-based in many ways — you can be simultaneously connected to many kinds of networks which could be human networks, the Internet, extranets, intranets, local area networks, etc. The working environment can be defined as a HyperPoint Network — a network of hyperpoints, which all contain data or knowledge. A hyperpoint can be for example, an information system, the Internet or a human being, another HyperPoint Network and more generally, any point which contains knowledge. People working in a virtual office communicate with these hyperpoints. The strength of a HyperPoint Network depends on how well it can utilise its tacit knowledge.

## **2.4 Multi-sensitive knowledge bases**

In the future, work will be done in knowledge-intensive HyperPoint Networks in which there is an abundance of both tacit and explicit

knowledge. Depending on the matter and circumstances, moment of time and so on, the tacit knowledge can be attached to explicit knowledge elements. The gathering of tacit knowledge (done by humans) can be speeded up by an active query system to a HyperPoint Network. By the means of the query system the existing explicit knowledge and the tacit knowledge attached to it gradually forms a multi-sensitive knowledge base.

To achieve the same or better level of gathering and producing knowledge than in traditional office surroundings one needs an efficient way to make queries over the Hyperpoint Network. The authors describe the idea of an operations model of an active query system, where queries can be made to any hyperpoint, regardless of whether they are information systems or human hyperpoints. Queries made to information systems are widely studied in general, and more specifically, queries to the Internet are studied within the research on the semantic web and sensitive links. For example in TUT Pori (Finland), there is very interesting research conducted on time dependant links. (Heimbürger, 2003)

The additional value of the idea is a query made to a human. In its most simple form it consists of a question made by a human (or by information system triggered by an event) and the background information supplied with the question. In such systems a query made by email to a human holds an address to database entry, where the information needed can be found concerning the question, and the answer can be put to the same database. Generally, if a human has the adequate amount of background knowledge supplied with the query, he or she can combine both explicit and tacit knowledge in their answer. Thus the benefit of a common working place — traditionally asking someone in the same office — is achieved.

### **3. THE LOIMAA EWORK CASE**

The Loimaa eWork case is a training and development project that includes the personnel consulting in enterprises and communities participating in the project. The project serves also as a research case. The main goal is to train key personnel who can transfer and utilise the results of research on virtual office in the target companies. The results of the study will be integrated with the existing solutions of business world and communities, giving a chance to create totally new patterns of work. We can improve their readiness to take the methods and wireless technology of teleworking into use, and furthermore, we can include meta-data based (additional data in accordance with the contents of information) handling and utilising of information in the company's own processes. One of the most important ideas is to find real applications for the idea of the multi-

sensitive knowledge base, as many of the companies are working with a distributed network. The target is to duplicate the results of this project and subsequently apply them to other companies. Also, research and business hyperpoints will be connected to the network, and then the flow of information will be faster and accordingly, the transfer and adoption of technology will be more effective. Other targets of the Loimaa eWork case involve integrating the study results and technology so that we get solutions which are useful in practice, in developing the information society, and in creating and utilising new working methods which take individuals into consideration.

An example of the new possibilities is the xTask working environment (Ketamo, 2002) which has been developed in TUT Pori. Another example is shown by the results of virtual office study (USIX part project of Tekes), with the definition of the virtual office as described in the section 2 above. The target of the Loimaa eWork case is to share the understandings of its operation with the participants to show how the new systems and methods can make possible cost savings.

### **3.1 Future results of the project**

The project is currently being conducted and most of the initial analysis has been carried out. The results of the study will be integrated with the existing solutions of the business world and communities, which will give us totally new patterns of work which can be used to better connect the methods and wireless technology of teleworking and meta-data based processing of information, as well as providing more information on the research of the concepts of hyperpoint networks and multi-sensitive knowledge bases.

The companies and communities working in the Loimaa eWork case can plan and carry out the development steps, which are offered by the developing technology in the future. In this way we can achieve competitive benefits and cost savings.

The authors have used analysis methods that give each person the possibility of participating. Due to these methods, a mutual understanding of the present stage of the firms' development has been established in a very short time. Whatever the problems have been, the process has been able to create a mutual understanding of the wholeness. This makes it easy to construct a plan for the future, i.e. how to use mobility or other modern technology. The final results will show how the goals are achieved, but so far the project seems to be on the right path.

## 4. CONCLUSIONS AND CHALLENGES

In order to define the virtual office, it is very important to understand the essence of the surroundings where virtual office is put in practise. This can be done by using the framework of knowledge intensive work. Furthermore it is important to understand the way end users want to use computer systems that enables virtual work. This is done by multi-view user interfaces that gives different user views to systems depending on the role and needs of the user. The hyperpoint network and multi-sensitive knowledgebase are means to understand large amounts of knowledge in order to work more efficiently.

As telecommunications services are not available everywhere at a reasonable price, the systems also have to support offline usage, in which case the synchronizing of knowledge between different systems is an absolute condition of successful working. You should be able to find the same up-to-date knowledge with any data terminal equipment from any location. The researchers do not find it necessary that all services are available in the same way in all different terminal devices, but the services can be applied according to the equipment and the mode of action. The equipment, which makes the virtual working possible, must support learning by working.

The biggest challenge derived from the authors' virtual office research is to study the definitions presented in this paper, the Hyperpoint Network and the multi-sensitive knowledge base and the query system enabling the gathering of multi-sensitive knowledge base. The ongoing Loimaa eWork case makes it possible to observe the implementation of these concepts in practice.

## REFERENCES

- Heimbürger, A. (2003). Modelling time-sensitive linking mechanisms. In H. Jaakkola, H. Kangassalo, E. Kawaguchi and B. Thalheim, (Eds.), *Frontiers in Artificial Intelligence and Applications (v 94): Information Modelling and Knowledge Bases XIV*. (pp. 26 –42) Amsterdam: IOS Press..
- Holmström, J., & Leppänen, V. (2002). *The Value chains in distance technology for small businesses and education, Virtual office and work community- part activity (VIRTO, Virtual office research report): USIX*.
- Ketamo, H. (2002). User and platform adaptation in web-based learning environments, Doctoral thesis, *Tampereen teknillinen korkeakoulu*, Julkaisuja, Tampere.
- Kuusinen, R. (2001) Inability to co-operate as a problem? In search of theoretical understanding of web-assisted knowledge-providing co-operation, Doctoral thesis, *Helsingin yliopiston kasvatustieteiden tutkimuskeskus*, Tutkimuksia 2/2001, Helsinki.

- Pekkola, J. (2002). *Telework in Finland; Physical, virtual, social and mental spaces as working environments for telework*. Doctoral thesis, Svenska handelshögskolan, Helsinki.
- Vartiainen, M., & Hakonen, M. (2002). The functionality of virtual teams. In *Proceedings of 6th International Workshop on Teamworking: 16-17 September 2002* (pp. 361-383). Malmö, Sweden: Malmö University: School of Technology and Society.

## **BIOGRAPHY**

John Holmström has experience in human-based development processes both in the academic world and in private companies. His research interests concern interfaces between human processes and technology in future work. Veli-Jukka Leppänen has experience of distributed organizations and ICT solutions. His research interests concern working and activity process environments in the future.

# INTRODUCING ORGANIZATIONAL CHARACTERISTICS IN LEARNING ENVIRONMENTS

Timo Lainema

*Turku School of Economics and Business Administration*

**Abstract:** We introduce some present day environmental characteristics affecting modern business organizations. We then argue why these characteristics should be taken into account when designing business-learning environments. The main message of the paper is that we need better learning environments that authentically describe the present day business environment, for example the process nature of business operations and the time aspect of decision-making.

**Key words:** Games, Teaching Methods, Organizations.

## 1. INTRODUCTION

The terms ‘knowledge work’ and ‘knowledge worker’ are only 40 years old. Today everyone uses these terms, but understanding their implications for managing people and making them productive is still not complete. Another relevant factor is environmental dynamism. Environmental dynamism is the product of several forces operating at one time. These include an increase in the size and number of organizations within an industry, and an increase in the rate of technological change and its diffusion throughout that industry (Li and Simerly, 2002).

During the 1980’s the planning loops in the product development and process times in the factory were shortened. New organizational structures enabled fast responses rather than low costs and bureaucratic control. Companies concentrated on reducing if not eliminating delays and using

their response advantages to attract the most profitable customers (Stalk, 1988). Probably the most significant single factor behind this development has been the use of computers.

Zuboff (1988) argues that new information and control systems have created an integration of production processes. This integration has created jobs that are intrinsically more responsible. The message underlying this new job structure is that being exposed to data implies that a person sees, comprehends, and is appropriately responsive. If organizations are to use information effectively, they must assign each decision to the person best able to make it. Often this will be a worker on an operational level, not a manager. Zuboff argues that this is the primary reason why work force needs a more general education.

This means a shift of emphasis inside the firms: facilitating cooperation among people takes precedence over enforcing compliance, and initiative becomes more valued than obedience. Organizations should make sure that everyone in the company knows how their individual contribution links to the company's overall aspiration (Hamel and Prahalad, 1994).

Zeleny (1989) describes the changes suggested by Zuboff and the other authors. The central or strategic knowledge is supplied to the individuals as an additional knowledge, needed by them in order to coordinate their own plans and action. Adaptation and responsiveness, ultimate decisions must be left to the people who are familiar with particular and local circumstances. Proper use of the locally operational knowledge increases organizational flexibility and its responsiveness to ever-increasing environmental dynamism. In a knowledge-oriented society, planning must be a process of continuous broadening of requisite organizational ability to cope with the ever-wider ranges of relevant internal and external fluctuations. Achieving flexibility demands increase in employee responsibility taking, self-control, and decision-making in ever-wider areas (Zeleny, 1989).

In this paper we will take a closer look at three different organizational environmental characteristics and how they have changed. Based on these changes we synthesize some suggestions that can be used to create authentic business learning environments.

## **2. DECISION-MAKING**

There are also changes that affect the whole decision-making procedure. Karin and Preiss (2002) note that business processes have various interactions, which have changed as the business world has moved from static to dynamic environments. Interactions have become more bi-

directional (compared to mono-directional) and they extend over a longer period of time and often deal with external situations.

Figure 1 (Karin and Preiss, 2002) illustrates the change that has taken place in organizational decision-making. The diagram on the left shows an iterative managerial process. It includes intake of information, analysis, decision and action. This creates a decision loop where information is transmitted once in a decision period, instructions are given and for the remainder of the period the actions taken do not change. The diagram on the right shows the same decision loop as a continuous dynamic process, where information is continuously gathered, decisions continuously reviewed, and the ensuing courses of action change continuously – as in many present day industries.

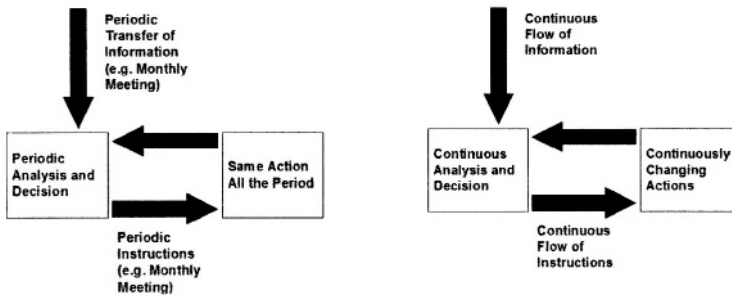

Figure 1. Development in organizational decision-making processes. (Karin & Preiss, 2002).

We could not verbalize the change in the environment better than Karin and Preiss (2002, p. 65) do:

When (the left diagram of Figure 1) applies to a business situation, the business model is piecewise static. Static because over one decision period the operational plan does not change, piecewise because at the end of a decision period the plan changes suddenly. When [the right diagram of figure 1] applies, the business model is dynamic – for example, suppliers to supermarkets that are required to replenish stock at least twice a day, according to sales data. Such a supplier continuously monitors the sales at all branches of the client supermarket...

The variables in this example, such as quantities to be stocked, are both continuous and dynamic. Continuous, because the values take continuous values, and dynamic, because the values of the variables change with time. In the past, the scenario above could have been expressed by a discrete and static variable. Imagine that the supplier takes orders once a month to supply



goods to a customer order in only four lot sizes: small, medium, large and extra large. The variable describing the quantity to be supplied is then a discrete variable, having only four possible values. It also is static, since once specified it remains unchanged for a month.

### **3. ORGANIZATIONAL STRUCTURES**

Businesses today often operate in competitive environments that are increasingly turbulent and unpredictable (Eisenhardt and Brown, 1999). The turbulence in the business environment and the technological change put pressure on organizations to be sure they can effectively meet the fundamental changes that are occurring (Scott Morton, 1991). External forces associated with environmental turbulence (social, political, technical and economic) and the timing of organizations' responses under such conditions have become crucial to firm survival (Scott Morton, 1991). There is no reason why organizations would necessarily continue in their present form. The environment may be so uncertain that no amount of analysis will allow us to predict the future (Scott Morton, 1991).

While bureaucratic organizations once dominated many aspects of society, most of them are being reshaped along with the challenges around them. This sometimes led to significant transformations (Morgan, 1989). This restructuring has taken place over the past decade, e.g. business units have increasingly taken the role of strategy formulation away from headquarters (Whitney, 1996). As a frame of reference we use a continuum describing the relationship organizations have to their environment. When environmental change becomes the order of the day, open and flexible styles of organization and management are required (Morgan, 1997). Table 1 illustrates extreme patterns of organization and management in organizations experiencing different rates of environmental change.

There are many aspects to be considered from the point of view of training and education in Table 1. Two most important for our field of interest are business processes and time (which have a linkage between each other; time is always embedded as one central factor in processes).

Table 1: Patterns of organization and management in organizations experiencing different rates of environmental change (after Morgan, 1997).

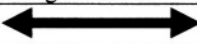
Attitude towards the environment	More or less ignorant about the role of the environment: a closed system that can be designed as clearly defined structures of parts. Goals predetermined, not designed for innovation => Great difficulty in adapting to changing circumstances. May lead to: "Wrong thing well" or "Right thing too late".	Open systems best understood as ongoing processes rather than as a collection of parts. Attention devoted to understanding the business environment defined by the interactions with customers, competitors, suppliers, etc.
	<b>MECHANISTIC</b> 	<b>ORGANIC</b>
	Mechanistic View; Organizations as Machines; Taylorian view	Socio-technical view; Organizations as Open Systems

For example, when arguing the need to understand business processes we refer to Hammer (1996) who states:

'In short, our problems lie not in the performance of individual tasks and activities, the units of work, but in the processes, how the units fit together into a whole.'

Dutta and Manzoni (1999) argue that the process view emphasizes how an organization actually does what it is required to do across departments and functions. The focus is on trying to communicate how an organization works together to create value for its customers, as opposed to how it is structured. This might imply the need for training which offers employees holistic understanding about the causal interdependencies of organizational processes.

#### 4. TIME AND DECISION-MAKING

Traditionally, the goal of management science has been to control uncertainty. But many scholars today admit that it is impossible to have total control over uncertainty. For example, Angell (1997) states that the only logical approach to management is to initiate plans, but to be flexible enough to react quickly to whatever risks or opportunities appear, and to maintain the initiative. A key element here is time, or the progress of time and the ability to live with it. There has been a clear understanding that time is closely related to organizational productivity and that time can be viewed as a resource to be managed. Time is considered one of scarce resources, one to be measured and manipulated in the interest of organizational efficiency and

effectiveness. One of the most difficult problems in organizational management is to bring objects to the right place at the right time. Bluedorn and Denhardt (1988) quote Moore (p. 8):

Thus one element of temporal ordering is synchronization. Other activities require that actions follow one another in a prescribed order; thus sequence is a part of temporal order. For still other activities, the frequency of events during a time period is critical; thus rate also is one of the ways that time impinges on social behaviour.

Bluedorn and Denhardt (1988, p. 304) argue: “*The problem of rate, sequence and synchronization are central to the understanding of time as an organizational resource*”. Today many groups in organizations must adapt their pacing of task behaviours quickly to changes in time resources. Barkema et al. (2002) found out that besides the speed of organizational processes and activities, also the pace of activities is an important factor. Different organizational processes require different paces and the management challenge is to discover and manage the optimal temporal progression of various processes. Also, time is not evenly distributed. For example, project work groups steadily increase attention to time as deadlines near (Gersick, 1989). Thus, organizations should increasingly pay attention to (a) causal interdependencies of organizational processes and (b) the time dimension of organizational functioning. This means that employees in organizations need to be more aware of the nature of these phenomena.

## 5. SYNTHESIS

The requirements discussed in this paper create a basis of demands that should be taken into account when designing learning environments. Here we conclude these requirements.

- The ‘Holistic View’ proposition goes as follows: If workers are to become adept at making informed decisions, they need to know the outcomes of their decisions; the cause-effect relationships of their decisions and outcomes. Specialism is not enough anymore, but initiative and a range of abilities should be possessed. Understanding how individual contribution links into the overall goals and ability to deal with novel situations demands from the learning tools/methods/contents above all the ability to deliver a holistic view of organizational and environmental functioning.
- The ‘Process and Time Dimensions of Organizations’ proposition goes as follows. The participants should be introduced to business processes that evolve as time proceeds. The decision-making starts from the operational

level. The dynamics between different organizational tasks and functions should be explicit (in the form of processes).

If we accept a view that learning is a kind of research process where the learner strives to gain understanding about the functioning of the phenomenon to be learned (= to be understood) then the goals of carrying out organizational research are in line with the goals of learning about organizations. Thus, the attributes of the approach of synthesis from Miller and Mintzberg (1983) support our aim of providing holistic process-oriented learning experiences. In the following, we discuss some attributes that Miller and Mintzberg (pp. 62-63) give for an approach that favours a synthesis of internally consistent processes, together with our view of how we have used these attributes in planning learning environments:

- A large number of attributes - ideally of state, process, and situation - are studied simultaneously in order to yield a detailed, holistic, integrated image of reality.
- Causation is viewed in the broadest possible terms. The holistic view of business operations representing networks of causation, not just unidirectional causation between pairs of variables or even multiple forms of causation. A system in which each attribute can influence all of the others by being an indispensable part of an integrated whole.
- Time and process are taken into account wherever possible.

We have applied these principles when constructing a continuously processed process oriented business game. Table 2 rounds up the differences in the characteristics of batch and continuous processing in the case of business gaming.

*Table 2: Differences in characteristics between batch-processing and continuous processing.*

Batch-processing	Continuous processing
More a mechanistic view: closed system that can be designed as clearly defined structures of parts.	Closer to an open system view: best understood as ongoing processes rather than as collection of parts.
Centralized decision-making on the highest level of the business organization.	Decentralized decision-making also on the lower decision-making levels close to the actual action.
Discrete; stagnant momentary views on financial and materials situation.	Continuous; the view is continuously evolving representing the process nature of business operations, on a transaction specific level.
Hierarchy, top-down view.	Process, bottom-up.

## 6. CONCLUSIONS

Our conclusion about the above discussion is that if workers are to become adept at making informed decisions, they need to know the outcomes of their decisions. As educators we need to be able to deliver a holistic view of organizational and environmental functioning. We acknowledge the need for providing learning tools, which represent realistic and complex models of reality, are authentic, facilitate continuous problem solving and meaningful learning, and embed learning in social experience. The propositions explicated here shape our conceptual model of how realism should be acquired and embedded in business learning tools.

## REFERENCES

- Angell, I. O. (1997). Welcome to the 'Brave New World'. In Stowell and Mingers (Eds.) *Information Systems: An Emerging Discipline?* (pp. 363-383). New York: Mc Graw-Hill.
- Barkema, H. G., Baum, J. A. C., and Mannix, E. A. (2002). Management Challenges in a New Time. *Academy of Management Journal*, 45 (5), 916-930.
- Bluedorn, A. C., and Denhardt, R. B. (1988). Tune and Organizations. *Journal of Management*, 14, 2, 299-320.
- Dutta, S., & Manzoni, J. (1999). *Process Re-engineering, Organizational Change and Performance Improvement*. London: McGraw-Hill.
- Eisenhardt, K., & Brown, S. (1999). Patching. *Harvard Business Review*, 77(3), 72-82.
- Gersick, C. J. G. (1989). Marking Time: Predictable Transitions in Task Groups. *Academy of Management Journal*, 32(2), 274-309.
- Hamel, G. & Prahalad, C. (1994). *Competing for the Future*. Boston: Harvard Business School Press.
- Hammer, M. (1996). *Beyond Reengineering*. Harper Business.
- Karin, I. & Preiss, K. (2002). Strategic Marketing Models for a Dynamic Competitive Environment. *Journal of General Management*, 27(4) 63-78.
- Li, M. & Simerly, R. (2002). Environmental Dynamism, Capital Structure and Innovation. *The International Journal of-Organizational Analysis*, 10(2), 156-171.
- Miller, D., & Mintzberg, H. (1983). The Case for Configuration. In G. Morgan (Ed.) *Beyond Method. Strategies for Social Research*. (pp. 57-73). California: Sage Publications.
- Morgan, G. (1989). *Creating Organization Theory: A Resource book*. California: Sage Publications.
- Morgan, G. (1997). *Images of Organization*. California: Sage Publications.
- Scott Morton, M. S. (1991). *The Corporation of the 1990's - Information Technology and Organizational Transformation*. Oxford University Press.
- Stalk, G. (1988). Time – The Nest Source of Competitive Advantage. *Harvard Business Review*, 66(4), 41-51.
- Whitney, J. O. (1996). Strategic Renewal for Business Units. *Harvard Business Review*, 74(4), 84-98.
- Zeleny, M. (1989). Knowledge as a New Form of Capital. *Human Systems Management*. 8, 77-90.

Zuboff, S. (1988). *In the Age of the Smart Machine. The Future of Work and Power*. Oxford: Heinemann.

## **BIOGRAPHY**

Timo Lainema has research interests in developing interactive and authentic business games for business education purposes. This research is multidisciplinary and includes such research topics as the impact of time in decision-making, business processes, structured versus unstructured decision-making, experiential learning, organizational learning and constructivist learning principles. Timo's email address: [timo.lainema@tukkk.fi](mailto:timo.lainema@tukkk.fi).



# DIGITAL COMPETENCE DEVELOPMENT AS STRATEGIC LEARNING

*A case of–business system implementation with digital competence development*

Kalle Mäkinen and Ari Alamäki

*TietoEnator Oyj, Arabianranta 6, FIN-00560 Helsinki, Finland*

**Abstract:** This paper reviews a successful digital competence development solution that was used to implement a business system in a large international organization. The following questions are examined: What makes a successful digital competence development case? What issues should digital competence developers consider? What aspects should management stress in corporate-wide business system implementation with digital solutions? The pedagogical requisites from the developers' viewpoint and return on investment from management's viewpoint are illustrated. The findings show that return on investment in digital competence development solutions can be reached if development meets business triggers. The findings indicate that if the solution is well designed, it is used creatively in several contexts.

**Key words:** competence development, learning models, business/commerce

## 1. INTRODUCTION

International knowledge-intensive corporations must constantly readjust their internal processes to meet the discontinuous challenges of the competitive landscape. Corporate-wide business systems play a key role in this endeavour (Tuomi, 2003). However, modern business intelligence information systems take us only halfway on the journey towards actual business excellence: business intelligence is intelligence only if it is in use and put to practice across the corporation (Brown & Duguid, 2000). The codified information in sophisticated business systems evolves into intelligence through effective utilization and concrete practices. What



follows is that effective competence development strategies that meet the challenges of digital economy are needed. The codified and articulated knowledge must be deployed to intelligence through concrete means.

Change management and knowledge management (Tuomi 1999; 2003) in a knowledge-intensive organisation share a common denominator: how to mobilize the strategic ideals and fads into practice? This article deals with one successful case involving a strategic-driven e-Learning solution that enabled a faster implementation of a new business system. The question this paper strives to answer is what makes a successful digital competence development (DCD) case? Can DCD triumph over the challenges of corporate-wide business system implementation? One of the major reasons why information systems fail is that they neglect actual practice and activity, i.e. how, when, why, and where people, and organizations, learn. Learning is a key issue in the competitive landscape. It is also a key concept that both developers of DCD solutions and management of the organization using the solutions must make explicit and understand. Learning and change go hand in hand, whether unlearning the old or learning new on top of the old practice (e.g. Wenger 2000; Ahonen 2000). For instance, a mistake caused by business process re-engineering was that it forgot practice and people; information systems were seen as a major cost-saving instrument that can be implemented top-down, independent from an organisational context, its phase of development and people (Davenport 1995; Malhotra 2002).

Traditional commodity-based information system delivery can serve well in operations that do not deal with the core processes of an organization. However, information systems for organizations' core processes require deep understanding of what makes the organization tick. A tendency towards close partnership-based models among IT service providers can be seen as an endeavour to provide information technology solutions that fit to context, processes and business—while not forgetting people either. So far only few IT service providers have been able to implement this model successfully – showing clear results of the superiority of the model.

A similar approach is needed when dealing with DCD; off-the-shelf e-Learning solutions can only deal with generic context-independent and general subjects. The case at hand shows that in implementing a business system that deals with the core processes of an organization, a tailored e-Learning solution is needed: the contextual needs of organisational learning and the organization's development phase must first be understood. Only then can DCD endeavours add value. The ability to understand this is essential, both on the supply and demand side of DCD.

The paper first describes the organisational context of the case and then illustrates the pedagogical concept of the solution. Next, empiric findings of

the case study are illustrated, and finally the cost effectiveness of the solution is scrutinized.

## 2. ORGANISATIONAL CONTEXT OF THE CASE

After years of mergers and acquisitions, the organization incorporated a number of different corporate cultures and ways of working. Its business intelligence was dispersed, tacit, or only partly codified in the old business system. The objective of the proposed e-Learning Solution was to enable faster and more cost-effective training of a new common business system throughout the organization. The learning need was strategic, and it was decided to use digital technologies to fill the gap.

The new business system was ready for implementation throughout the organization; it would replace the older systems. Change management activities were necessary, and users needed to be retrained. A tool that would enable training independent of time and location was essential in this networked organization. Consistency and follow-up of the efficiency of the implementation were required by management. Management needed to assess the actual use and cost-effectiveness of the training solution internationally. Figure 1 illustrates the organisational context, and challenges, that the digital learning solution was created to answer.

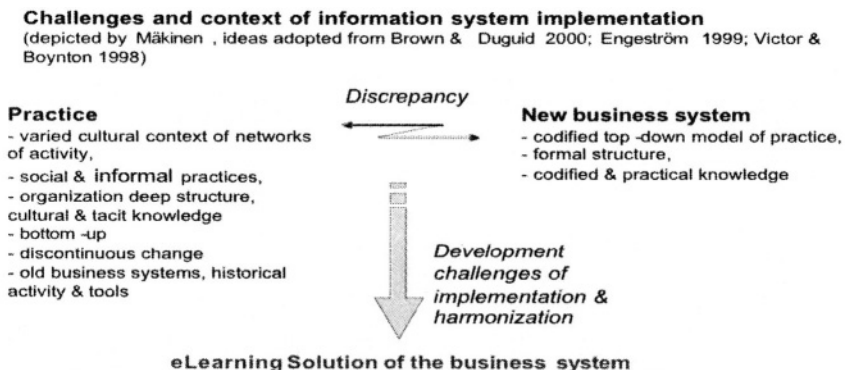

Figure 1. Organizational context of the e-Learning solution.

A traditional training approach was considered too expensive to implement. Moreover, a more scalable solution to fill the competence need was needed. Instead of performing a heavy road show about the new business system, the e-Learning solution enables training in the same place

where users face the learning need. In addition, a stand-alone solution that would fit into diverse platforms, intranets and content management systems was needed.

### 3. PEDAGOGICAL DESCRIPTION OF THE SOLUTION

Pedagogically sound DCD tools must be used in order to provide answers to organisational strategic needs. Pedagogical concept designers and consultants are needed to keep the development on track. Bloom's (1956) taxonomy can be used to structure types of knowledge and depth of learning. Different DCD approaches (e.g. self-study, blended learning architecture, and computer-supported collaborative work) are positioned in Figure 2 according to the learning needs and objectives they address.

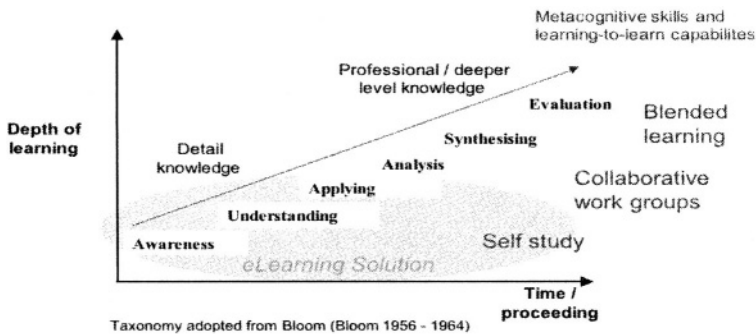

Figure 2. Depth of learning and knowledge of the business system e-Learning solution

The depth of learning of a new business system is three-fold: Firstly, organisational members must become aware of the new business system and understand the additional value that it can bring to their daily business. Secondly, they must understand the codified knowledge in the business system. They must also understand the logic behind using the business system. Thirdly, they must be able to apply to their work what they have learned about the business system. If the depth of learning and level of knowledge are retained only in the level of understanding, the organisational intelligence will be lacking. Applying knowledge brings more value for business purposes and needs. Management in the customer organization and developers of the DCD solution can reap the greatest benefits from the solution if these aspects are addressed in the competence development

project. We point out that, for instance, blended learning solutions represent the total picture of e-Learning. They can be used for several learning objectives. Training about a common business system can be also deployed using blended learning methods and architecture; however a self-study e-Learning solution fulfils also the prior needs of the training. An interesting remark on the DCD case at hand should be made: though it was originally designed for self-study purposes, the quality facilitators used it as a blended learning solution.

#### 4. EMPIRICAL FINDINGS

Six end-users (quality managers, project managers) of the e-Learning solution were interviewed for this article. Also, the management team of the organization was interviewed (HR management & HR development in Finland and USA). The interviews were conducted as structured theme interviews. The same questions were posed to both the users and management. Moreover, the writers of this article have themselves been developers (pedagogical expert, pedagogical concept designer) of the e-Learning solution.

*Table 1. Interviewed personnel*

<b>Interviewed personnel</b>	<b>Work roles</b>
<b>Management team of the organization:</b>	- HR manager (Finland), - HRD –manager, - VP development - HR manager (Subsidiary in USA)
<b>End users:</b>	
<b>Four users in Finland</b>	- Process developer, - team leader, - logistics development manager, - two project managers
<b>One user in Denmark</b>	- Quality facilitator for the business system rollout
<b>Two users in Norway</b>	- Quality facilitator for the business system rollout

The interviews (see Table 2) showed that the e-Learning solution was used more creatively than is usual for a self-study tool. This shows the flexibility and adaptability of e-Learning solutions to fit with varied needs of a given organization. If the solution is strategically and conceptually sound, solution will conform to the organization's phase of development and business triggers. What follows is that the organization applies it creatively.

Table 2. Excerpts from interviews.

Management's illustration for what the solution should be	End user experiences about what the solution is and how it was used
<p>“Training geographically dispersed organization's personnel effectively, and with common solution.”</p> <p>“Training new users to use new business system version.”</p> <p>“Training old users to use new business system version.”</p> <p>“Lead users to learn in a self directed manner.”</p> <p>“Enable continuous and repeatable training and implementation process.”</p>	<p>“We used it before the roll-out sessions of the new business system.”</p> <p>“We gave it to users for orientation before any formal training.”</p> <p>“I have used it sometimes after the orientation when I need to refresh my memory about it.”</p>

## 5. DIGITAL COMPETENCE DEVELOPMENT COST EFFECTIVENESS

The debate on measuring learning and its cost-effectiveness approaches that of measuring intangible assets (Sveiby 1997). We present three factors that affect the cost effectiveness of digital competence development. If these factors are met, the cost-savings and return on investment (ROI) can be significant per enrolled student/person.

- The e-Learning solution can be studied by sections; the estimated time is two hours and in classroom training, the estimated time is three hours. More time is spent when transportation costs to the venue are calculated. Major timesavings can be achieved.
- When the trainers and other personnel travel to several locations, costs can rise significantly if the implementation is ongoing and new personnel must be trained continuously.
- Using a classroom does not guarantee good learning results; evaluation of what was learned, and the transfer of learning, may be problematic.

DCD solutions can be used whenever they fit into a user's timetable and whenever the learning need arises. Keeping the third factor in mind, together with measuring learning results compared to traditional classroom training, can bring cost-savings. The use of classroom sessions is difficult to measure, costs too much, or takes too long, whereas the user report function does it automatically. The user reporting, ROI (and its measurement) deserve more thorough examination.

## **6. DISCUSSION**

In the introduction we asked ‘what makes a successful DCD case?’. ‘Can DCD triumph over the challenges of corporate-wide business system implementation?’ We conclude this paper with four remarks on these questions:

- Business system implementation is an ongoing process that a DCD program can support and expedite. It goes hand in hand with wider organisational processes and change management activities. The accumulative data from the reporting function of the system shows that the e-Learning solution is in continuous active use. An interview with a US-based subsidiary revealed that the e-Learning solution could be used to meet their local needs; it serves as a strategic tool to HR management and for quality management.
- An e-Learning Solution can only reach its objectives if they are well conceptualised and designed, taking into account strategic organisational learning needs. The e-Learning solution was created in a need-push situation (Fleck 2002); the organization had a clearly defined strategic need for an e-Learning solution. The e-Learning designing process proceeds iteratively, as does any development process. A customer need must be formulated into concrete means, actions and solutions. e-Learning can also create demand pull. A reporting function can be used to anticipate such aspects.
- The multifaceted aspects of organisational learning should be considered, e-Learning being one important aspect. However, its connection with other organisational learning aspects is systemic; e-Learning can support, enhance or exploit both informal or emergent and complex learning in an organization (Stacey 2001). It can be used as an operational instrument in meeting clearly defined management needs.
- There can be a significant return on investment if the number of users exceeds economies of scale and geographical dispersion is wide. e-Learning solutions can be used for mass training purposes, ongoing orientation procedures, and as part of traditional classroom sessions.

Complex and creative organisational realities and practices ultimately define how the DCD solutions are actually used. Future research should examine an organization’s maturity and dynamic capabilities in relation to the use of DCD solutions.

In conclusion, managerial strategies must align with the pedagogical concepts of the digital competence consultants in order for strategic learning experiences to occur through DCD means.

## REFERENCES

- Anderson, L., & Krathwohl, D. R. (2001). *A taxonomy for learning, teaching and assessing: A revision of bloom's taxonomy of educational objectives*. New York: Longman.
- Bloom, B. S. (Ed.) (1956). *Taxonomy of Educational Objectives*. New York: David McKay Company Inc..
- Brown, J. S., & Duguid, P. (2000). *The Social Life of Information*. Boston: Harvard Business School Press.
- Davenport, T. H. (1995). The fad that forgot people. *Fast Company*, 1(November).
- Engeström, Y. (1987). *Learning by expanding*. Helsinki: Orienta-konsultit.
- Engeström, Y., Engeström R., & Vähäaho T. (1999). When the centre does not hold: The importance of knotworking. In S. Chaikli, M. Hedegaard, & U. Jensen, (Eds.), *Activity theory and socialpractice: Cultural historical approaches*. Denmark: Aarhus University.
- Fleck, J. (2002). The structure of technological evolutions: Linear models, configurations, and systems of development. Paper presented to Nobel Symposium on Science and Industry in the 20th Century, Stockholm 21-23 November.
- Victor, B., & Boynton, A. C. (1998). *Invented here: Maximizing your organisation's internal growth and profitability*. Boston: Harvard Business School Press.
- Lave, J., & Wenger E. (1991). *Situated learning: legitimate peripheral participation*. New York: Cambridge University Press.
- Malhotra, Y. (2002). Why Knowledge Management Systems Fail. In C. W. Holsapple (Ed.), *Handbook on Knowledge Management*. Heidelberg, Springer-Verlag.
- Nonaka, I., & Takeuchi, H. (1995). *The knowledge creating company: How the Japanese companies create the dynamics of innovation*. New York: Oxford University Press.
- Senge, P. (1990) *The Fifth Discipline: The art and practice of the learning organisation*. New York: Doubleday.
- Stacey, R. D. (2001). *Complex Responsive Processes in Organisations: Learning and Knowledge Creation*. New York: Routledge.
- Sveiby, K. E., (1997). *The New Organisational Wealth, Managing and Measuring Knowledge-Based Assets*. San Fransisco: Berrett-Koehler
- Tuomi, I. (1999). *Corporate knowledge. Theory and practice of intelligent organisations*. Helsinki: Hakapaino.
- Tuomi, I. (2003). The future of knowledge management. *Lifelong Learning in Europe*, 7(2), 69-79.
- Wenger, E., & Snyder, W. M. (2000). *Communities ofpractice: Learning, meaning and identity*. Cambridge: Cambridge University Press.

## BIOGRAPHY

Kalle Mäkinen (M.Ed.) is a pedagogical concept designer in TietoEnator's e-Learning solution unit. He is undertaking a PhD about corporate strategy & knowledge management. His research interests are organisational learning, partnerships, networked/extended enterprise, boundary crossing, collaborative learning and knowledge management.

# THE IMPACT OF THE IMPLEMENTATION OF DISTANCE EDUCATION SYSTEMS IN A TELECOMMUNICATIONS COMPANY

Marina K. Nakayama<sup>1</sup>, Raquel Proano<sup>1</sup>, Bianca Pilla<sup>1</sup> and Ricardo A. Silveira<sup>2</sup>  
*<sup>1</sup> Universidade Federal do Rio Grande do Sul – UFRGS, <sup>2</sup> Universidade Federal de Pelotas – UFPEL*

**Abstract:** This paper describes research carried out at a telecommunications company, focusing on the changes caused by the implementation of Distance Education Systems (DES) for employee training. The objective was to analyze these changes from six points of view: structural, technological, cultural, political, strategic, and human, based on Motta's analytical chart (1997). The research also tried to detect how to identify resistances generated with the implementation of the DES. Results show that there is a global consciousness that the DES represents an interesting learning alternative, and because of this, employees proved to be in favor of its use.

**Key words:** learning organizations, on-the-job training, learning systems

## 1. INTRODUCTION

We have noticed that some organizations are employing new approaches to management, with new parameters that allow them to follow world changes effectively. One of these strategies appears to be in the development of abilities and skills of those who take part in a company through the use of technology applied to capacity building plans. In the search, information technologies aided in the development of interesting teaching and learning alternatives, such as in the case of Distance Education, a system that is being used in capacitation courses for employees that want to have a competitive plus within the competition environment they are embedded.



The use of Distance Education offers benefits such as the fact that workers do not need to leave their working area to attend a course. There is also interactivity between students and teachers, the creation of virtual multidisciplinary and dynamic teams, operational cost reduction, among others.

However, the introduction of this kind of system may imply a number of different challenges. As a technology to be applied, it may cause an impact on the organization. While the technologies become more complex, demanding a bigger effort from the people in their implementation, it is fundamental that the assessment of their impact is not only in technical and financial aspects, but also concerned to issues of the organization and its capacity of accepting and supporting organizational changes decurrent to a technological implantation (Graeml, 2000).

Therefore, in this context, the present research tries to analyze changes generated after the introduction of a distance education model, considered an information technology, in a company named Telek. This company makes use of Distance Education for human resource training and development. Telek is a fictitious name in order to protect the company's identity.

In the following sections we discuss some theoretical issues about important changes in the organization, the research methodology used in this work and the obtained results.

## **2. CHANGE PHENOMENA AND THE SIX PERSPECTIVES OF ANALISYS**

When discussing the term 'change' we often refer to technological, economical, political, and social variations and innovations that have influence in the everyday life of any kind of organization. Many models and theories, models under new paradigms that apparently represent reality in a better way, strongly arised in these last few decades, aiming at transforming, evolving and managing better the changes (Motta, 1997). Many of these models are not more than copies of other experiences that have nothing or little to with the reality of the environments where they would be applied. In fact, we could say that there is not a single model to guarantee change efficacy, as well as the contingency theory tells that there is not a single model to successfully administer the organization. All is relative and depends on the analyzed context.

The current trend is that each organization tries to develop an action plan that is coherent with its internal and external condition, which requires a particular work of creativity and innovation.

Motta (1997) considers that the construction of theories to understand the change phenomena can be justified by the ability of explaining reality and by a practical application in administrative problem-solving. We highlight six perspectives for understanding the global change phenomena:

1. *The strategic perspective* sees the organization as an open system inserted in a changing social, economic and political context, privileging the way one relates with society, through its products and services. It makes way for decision making, considering the information flow between the organization and its environment. One considers that to change an organization it is necessary to redefine its mission, objectives and ways of identifying and selecting action alternatives.
2. *The structural perspective* sees the organization as an authority and responsibility system, which defines the action realm of each person, and the consensus and subordination to attend specific functions already set. It assumes the previous definition of the worker's formal role as a main factor of efficiency. We then conclude that in order to change an organization it is necessary to change the way how authority and responsibility are formally distributed.
3. *The technological perspective* focuses on the work division, function specialization and the kind of technology to be used. One may say that the inference pattern with relation to changes is the alteration of its technology, function specialization and their productive processes, that is, to reconsider the way how material and intellectual resources are used.
4. *The human perspective* as for example: leadership, motivation, communication, skills development and aptitudes. The human perspective concentrates on the link between work and the individual, highlighting factors of motivation, leadership and other psycho-social factors that lie under the institutional prescriptions and authority lines set formally. We believe that in order to change an organization it is necessary to modify attitudes, behavior and the way how individuals participate, through an incentive to collaboration, motivation practices, leadership and reconstruction of the career rewarding system and personal qualification.
5. *The cultural perspective* sees the organization as a set of values, beliefs and habits collectively shared that typify and differentiate the organization from others. These cultural expressions are perceived in the structure, in the authority, in meetings, in ways of communication, among others. This model gives priority to what is collectively shared and individual behavior and attitudes. In the change, we believe it is important to substitute the collective program in the search for a new sense of identity, as if it were a collective enterprise to alter the people's values.

6. *The political perspective* considers the organization as a power system where people or groups look for more influence in the decision process. Power is seen as an end in itself. With relation with change, this model finds it necessary to bring about a power distribution, in order to satisfy new action priorities. In this case, to change an organization becomes interference in the ways how interests are articulated and aggregated and how the power between coincident and conflicting individual interests balances. This includes internal negotiation and conflict solution (Motta, 1997).

In past decades, resistance to change was explained in terms of technological inadequacy or ignorance; one would try to eliminate it simply by trying to force people to submit to the new order. Today, resistance to change is seen to stem from both individuals and organizations. The origin of the former is the individual perception caused by resistance to novelty, fear of the future (or status quo loss), habit, or loss of security (Robbins, 1999). As innovations progress, resistance to them takes different forms over time. Initially, resistance is strongly focused on personal characteristics and subsequently shifts to organizational issues. Today, resistance is seen as something as natural as change itself, and as a source of criticism and creativity, and as a better use of human abilities (Motta, 1997).

### **3. THE RESEARCH METHOD**

This research used both qualitative and quantitative methods. A descriptive study employed interviews and document analysis, while questionnaires were used to gather quantitative data. These were both applied to the management levels, distance education experts, and employees that attended the courses. 949 questionnaires were sent via e-mail, and of those, 219 were answered. The company where this research was carried out introduced the Distance Education System in the state of Rio Grande do Sul in 1996. Since then it has undergone several changes, stages, and challenges.

### **4. ANALYSIS**

The DES collaborated in a way to reach certain strategic goals of the organization, such as customers' satisfaction through distance training courses for employees. This change opened the internal and external communication systems and generated new ways of acting, thinking and involving the participants of the customer-supplier-worker process. Besides,

the internal public became more aware about the organization purpose, a concept that meets Motta's (1997) ideas.

We highlight that this innovation occurred not only because of the competitive environment of the telecommunication area, but it also has to do with fulfilling institutional requirements of this environment, such as those of Anatel (a regulating telecommunication agency), that controls product and services offered to customers so that the company meets quantity and quality indicators. This requirement obliges the company to improve its management policies. Thus, the position of authors such as Morgan (1996), Tolbert & Zucker (1999) is confirmed.

According to the results, there is not enough evidence to deduce that there were structural changes after the DE System implementation. However, we do not observe any change that has to do with the distribution of responsibilities, authority, hierarchy, re-distribution of rights and duties, and flexibility of formal limits, as affirmed by Motta (1997). These results may be also due to the fact that some specific affirmations that questioned this topic were not considered convenient and therefore were not taken into account in the final questionnaire, what made the task of finding structural change evidences more difficult.

We emphasize that this system is at an early stage and it is not available to all areas in the company, what makes the possible occurrence of changes still more difficult.

Results show that the applied leadership process, according to Likert's categories, shows little relationship and support of superiors to subordinate workers. Leaders do not motivate subordinates to discuss ideas, suggestions or opinions about the DE System. Lack of motivation and little participation of subordinates are perceived in this aspect.

This change process is characterized by little interaction and communication drawn towards objectives accomplishment. It does not fulfill the objectives of an open, fluent and sufficient communication, so much with the people that coordinate the DE System and the management level, just as the management level and employees.

This characteristic even seems to have some influence in the aim of changes proposed by Motta, which is to open a space of motivation, personal and professional satisfaction for the workers. There is low motivation and commitment of Telek workers on attending distance courses. We verified that the motivational element is still an inhibiting factor in the process on a Distance Education application.

An important aspect of this study is that the participation in distance courses is voluntary, presenting a style of management closer to a participative style, which results validate Likert's position. Although other results show that even if it is not a formal requirement of the company that

employees attend a distance course, there are subjective factors that make the worker feel compelled to attend certain courses the DE System offers.

As for changes in workers' behavior and attitudes in their work after the DE System implementation, there are divergent results.

The respondents of the Third Level found that there were no changes, on the other hand, the respondents of the First and Second levels believe that they have noticed some differences after the DE System usage.

Although we observe that there were changes in the worker's behavior as for his/her learning, the generated trend in search of new knowledge, to give value to information and to permanently learn is being built. The worker may keep on studying on his/her own, controlling his/her own learning, fulfilling the autonomy principle of learning proposed by Peters (2001).

For Telek, culture change becomes the foundations for the DE System. The company believes that self-controlled and independent autonomous learning, are principles that the worker must follow. The company also believes that they have changed learning habits, ways of conceiving self-development, even time availability dedicated to this activity, because the virtual learning model is very different from the traditional model.

However, we point out that despite the availability and aperture that workers show to attend distance courses, there are drawback elements that prevent this DE System objective. The continuous interruptions during time dedicated to virtual training, the required demands done by the company, and less time dedicated to learning, do not allow the worker to benefit from this technological tool, nor to consolidate his/her new position.

Workers insist on this point and are very clear, expressing their problems to match the time the company makes available for qualification and the real time they have to accomplish it effectively.

## 5. DISCUSSION

We observe that the level of idea exchange, suggestions and impressions on the DE System are minimal and, making it difficult to set forth a new equilibrium where people involved can set their values through negotiation, specially in what concerns the DE System. We cannot even infer that the DE System generated changes in the distribution of resources of the overall organization, that is, there is no evidence that supports this hypothesis.

Based on the analysis of six perspectives, we may sum up reasons for the resistance to the DE System at Telek presented by its users:

- *Motivation*: is a factor that makes the change process difficult. The origins of lack of motivation result not only from the resistance to change

itself, but to the organizational surroundings where the worker is inserted and has some influence on his motivation.

- *The change itself*: is the fear of the unknown. The dread of novelty, insecurity in relation to this change process, as mentioned by Motta (1997).
- *Fulfillment of the organization goals*: the demand for goals, objectives and requirement fulfillment diminish the worker's time. The requirement of results generate a lack of time for self-development during working hours
- *Planning of DE System goals*: the lack of the involvement of main characters, such as workers that receive management courses and the team that directs the DE System, in the construction of common goals, objectives, idea exchange and suggestions makes the construction of dialogue spaces more difficult and generate resistances, as mentioned by Robbins (1999).
- *Technology use*: there are people that do not get familiar with the Distance Education technology, as pointed by Graeml (2000).
- *Application of virtual to concrete*: the difficulty in dealing with something that is not physical makes it difficult to accept the DE System. The lack of physical interaction with other colleagues that attend distance courses also causes some resistance
- *Habits*: the traditional education habits still must be overcome. These factors inhibit some workers to accept a new capacitation methodology. It is a long and adaptative process, according to Motta (1997).

Nevertheless, there are other reasons, besides those the interviewed people pointed out that may explain resistances. They are not only for the reasons exposed above, but also because the worker loses his or her identity due to the lack of positive answers by the environment where he/she is placed. These other reasons would be:

- their superiors do not stimulate them,
- the environment of change in the whole organization,
- the low level of exchange of ideas.

These and other factors end up having some influence on the workers' attitudes towards the new technology - in this case, Distance Education.

## REFERENCES

- Graeml, A. (2000) *Sistemas de Informação. O alinhamento da Estratégia de TI com a Estratégia Corporativa*. São Paulo: Editora Atlas.
- Motta, P. R. (1997) *Transformação Organizacional. A teoria e a Prática de Inovar*. Rio de Janeiro: Editora Qualitymark..

- Robbins, S. (1999) *Comportamento Organizacional*. São Paulo: Editora Pioneira.
- Tolbert, P.; Zucker, L. (1998) A Institucionalização da Teoria Institucional. In: Clegg et. al. (Eds.). *Manual de Estudos Organizacionais. Modelos de Análise e Novas Questões em Estudos Organizacionais*. São Paulo: Editora Atlas.

## **BIOGRAPHY**

Marina Keiko Nakayama is a professor at Business School at the Universidade Federal do Rio Grande do Sul. Raquel Proano is an undergraduate student and Bianca Pilla is a graduate student at the same school. Ricardo Azambuja Silveira is a professor of Computer Science at the Universidade Federal de Pelotas. Their research interest is design and the use of virtual relationship e-learning and Distance Education in Human Resource Development.

## **ACKNOWLEDGEMENTS**

This research was funded by a grant from the Brazilian research agencies: CAPES - Coordenação de Aperfeiçoamento de pessoal de Nível Superior, CNPq - Conselho Nacional de Desenvolvimento Científico e Tecnológico and FAPERGS - Fundação de Amparo a Pesquisa do Rio Grande do Sul.

# THE PERFORMANCE OF VIRTUAL TEAMS

## *An Analysis based on Indicators*

Marina K. Nakayama<sup>1</sup>, Michelle d'Ávila Matoso<sup>1</sup> & Ricardo A. Silveira<sup>2</sup>

<sup>1</sup>Universidade Federal do Rio Grande do Sul - UFRGS <sup>2</sup>Universidade Federal de Pelotas - UFPEL

**Abstract:** Virtual teams have recently provided an alternative way of organising work in organizations. The efficient management of virtual teams is a key component of overall organizational management. The objective of the present work is to analyze the performance of two virtual teams. Data collection was based on interviews, surveys, minutes of meetings and observation. This study verified that the support offered to virtual teams was not effective if the particular characteristics of the virtual teams, as well as their complexity, were not taken into account. We highlight the importance of considering success factors in virtual teams: adequate technology, Human Resources policy that offers support to the virtual worker, training of leaders and members, standardized work procedures, and leadership skills.

**Key words:** user groups, virtual learning organization, evaluation/formative

## 1. INTRODUCTION

The working world is changing rapidly, and technological development is a determining factor of this change. Technological change, the advent of the Internet, and new distance communication facilities (e-mail, audio and video conferencing) create new possibilities for teamwork in which people can work together to develop their projects even if they are not in the same physical environment. Virtual teams arise within this context: they are groups of workers, geographically distant, that interact through computer-based communication. As virtual teams are rapidly becoming common workplace realities in organizations, the efficient management of these teams constitutes a key component of an organization's managerial responsibilities.



The objective of our research is to answer the following question: What are the indicators of a virtual team's performance? In the following sections we discuss some theoretical issues about virtual teams in organizations, the research methodology employed in this work, details of the particular case study examined here, and our findings from a study of two virtual teams.

## 2. VIRTUAL TEAMS

Virtual teams are part of the most recent phase of organizational evolution. In the nomadic era, the formation of small groups marked the first invention of ways of structuring people in organizations. This convention evolved very quickly and people started to organize themselves in cities. A more bureaucratic form of organization was required during the Industrial Revolution. Today, the World is in the information era and another mode of organization has begun to arise: the networked organization (Lipnack & Stamps, 1999). It is within this new organization that virtual teams are embedded. According to Zimmer (2001):

'Virtual teams are work groups composed of people that interact at distance, in a provisional or permanent way, in a company and/or network of which they take part, and that, using advanced technological devices keep in touch and carry out their tasks, trying to reach common goals.'

This kind of team, as with any other, is a group of people with different opinions and different levels of relationships, guided by an organisational objective. They differ from traditional teams by the fact that they work in different places, time and organizational boundaries.

Duarte & Snyder (1999) identify the existence of some critical success factors in virtual teams. The factors that affect the probability of a team performing at a high level are technology, human resources policy, training and development for leaders and team members, organization and team process patterns, organizational culture, leadership, and leader and member competency. Duarte & Snyder (1999) have identified the following seven types of virtual teams:

1. *Network teams*: those with a capacity for aggregating members who are not from the same organization, such as participants of the clients or suppliers' network, or even autonomous experts. For instance, contracting an expert on aeronautics to take part in the development of a new aircraft model for a virtual team of an aircraft building company.
2. *Parallel teams*: those that 'carry out missions, tasks or special missions that the organization does not want or is not equipped enough to perform'

(Duarte & Snyder, 1999, p.6). Normally their action is for a short period and they aim at suggesting improvements of internal processes or specific business issues.

3. *Project or product development teams*: they are intended to develop new products and organizational processes or, moreover, the creation of information systems, not used for routine tasks. These teams have higher life cycles, besides the possibility of implementing their decisions and not only suggesting recommendations.
4. *Work or production teams*: applicable to the routine and ongoing works that often affects a department.
5. *Service teams*: to carry out services for clients—such as consulting.
6. *Management teams*: composed of ‘moving’ business people who meet through a video or audio conferences to discuss and make decisions. In these teams, members are part of the same organization.
7. *Action teams*: used with the aim of ‘offering immediate answers, often in emergency situations’ (Duarte & Snyder, 1999, p.8).

We verified that both employees and employers value the advantages of virtual teams. Employees benefit because they save the time that was once spent going to other company units to take part in meetings, and thus they have more time to do their work. However, organizations must be prepared to implement and maintain the necessary technology for teamwork to function effectively. It is also necessary that organizations provide adequate training and support in the effective use of communication and collaborative technologies.

Employees need to have discipline and work in different schedules. They need to know how to use the available tools, and must be aware of the difficulties that the lack of physical contact may bring to their participation in virtual teams: possible communication noises, lack of motivation or even of confidence.

### **3. RESEARCH METHODOLOGY**

This work used a qualitative case study methodology. The methods used for data collection included interviews, surveys sent by e-mail, analysis of e-mail messages and direct observation of developed works. In addition there were a number of meetings to discuss the research goals. All members from both teams collaborated with our research. The company research was carried out was at *Effen Brasil*, a North-American company which represents food products in Brazil.

## **4. EFFEM BRASIL VIRTUAL TEAMS: HISTORY AND OPERATION**

Based on our observations and interviews, the following reports on the history and operations of the Alfa and Beta virtual teams from *Effem Brasil*.

### **4.1 The Alfa team**

The Alfa team has been operational since November 2001. It consists of 17 members from the units of Eldorado do Sul (Rio Grande do Sul, Brazil) and Mogi Mirim (São Paulo, Brazil). Not all of the participants know each other personally. The objective of this team is to re-launch a well-known company trademark.

The team leader responsible for the trademark in Brazil counts on the support of representatives from all necessary areas, such as business (food products sale), research and development, purchasing, services and finance. Each member has a particular personal role within the team, depending on his or her area of responsibility.

The team is currently undergoing a period of change due to the company's location and its difficulties in achieving sales goals. There are no expectations for deadlines, projects or funding approval. This is because the company is facing a merging period, and projects must wait for directorate approval. According to the team members, this is generating a lack of motivation and commitment. The leader has tried to make all information as transparent as possible to warrant the comprehension and confidence of all team members.

### **4.2 The Beta team**

The Beta team has been working for about four years. The team's objective is to strengthen the brands of a certain business segment, and to reach financial goals. The team consists of a group of 15 members from the units of Eldorado do Sul and Recife, in Brazil. Not all team members know each other personally.

The team leader conducts the meetings, and starts by reading the minutes from the last meeting in order to check what has not been solved. Each ongoing project leader presents the current situation of activities.

Team communication is clear and objective: it makes good use of e-mail, telephone and video-conferences. All team decisions and processes are documented and given official status in order to avoid communication problems.

The Beta team is currently well motivated. Members are interested and there is significant participation. Although the company is in a period of change, apparently this team has not been affected by it. Perhaps this difference in behavior is because this team had great results in the past year, which makes the company interested in developing their projects, releasing funds and approving their projects more rapidly. This way one can realize that the external set has an influence on team performance.

## **5. RESULT ANALYSIS AND DISCUSSION**

This section presents the research data and our findings.

### **5.1 Results**

This research identified and analyzed possible indicators of the performance of the two virtual teams. Both teams have different realities, and act in different branches and have different goals. The Alfa team is going through a complicated period and the company is re-defining the focus of their work. The Beta team is in a confident phase, in which members are committed and interested, as well as successfully completing their projects.

Members were asked to identify factors that influenced their team's high and low performance, and also to describe other factors that might affect the virtual team's overall work. Factors mentioned as being responsible for the team's high performance included commitment, having clear goals and the team members' motivation. The most cited factors affecting a team's overall virtual work, were adequate communication, leadership and good guidance.

The Alfa team considers that the possible cause of their low performance at this moment is due to the company failing to clearly define what it wants them to accomplish. On the other hand, they also believe that good leadership is a factor that will be responsible for the expected high performance when such definitions are finally set. Moreover, they say that the team is integrated; they all have well defined roles that may help them to perform at a higher level. The Beta team considers their good performance is due to the team's integration, well-defined objectives and to the commitment of all its members.

### **5.2 Analysis**

Most of the characteristics and factors that may bring success to a team, besides being very much alike, work well for both the traditional and virtual

teams. (Drexler,1995; Scholtes, 1992) However, some are more critical in virtual teams than in real-world teams.

The first characteristic is orientation. It is necessary that all members know why they are taking part in a team, and have an understanding of why the team exists. In a virtual team, where there are not many physical or face-to-face links between people, it is essential that one knows what the team's goal is. Therefore, the first point to be set in the process of a team development is to guarantee guidance. In our observations we verified that both teams are well directed about their mission, and why their members were selected to be part of it.

After the first phase is accomplished, another critical characteristic is confidence. It's easier to trust people when they are close and you can see their performance at work, than it is to trust someone that you do not know personally and do not see how they work. Building confidence is essential in a virtual team because working at a distance without rigid control requires people to really believe that their team partners are conscientiously performing their work as previously arranged. Perhaps, due to the fact that the Beta team has already obtained positive results, they are confident about the other members' performance, and their work has become easier.

The third phase is to clarify what the team is attempting to achieve. It is necessary to define the roles and make the objectives very clear; good communication is a critical factor. In a traditional team it is possible to perceive signs of comprehension, and also to observe gestures and expressions. This is not possible in a virtual team. Besides sending a message, it is essential that a virtual team guarantees that the person who is receiving the message understands it. The Beta team worked out this phase very well. Alpha team, however, did not because it did not have its objectives well defined.

Subsequently, it is important to get an explicit commitment from all members about how they will carry out their activities. Such a commitment is a critical factor in a virtual team's success. If the participants do not demonstrate commitment to the tasks and the team, all group activities may be ruined. In a team, each member plays a crucial role; if someone does not accomplish his or her activity, the team's performance may be affected. Clear communication and feedback are essential in this phase.

The fifth phase mentioned is implementation. Who makes what, when and where must be defined in a consensual way. All members must take part actively in this phase in order to keep the commitment with the tasks.

After all these phases are concluded, a team can aim for a high level of performance. However, teams are dynamic and need to be sustained. After a high level of performance, they need to review the factors that led to their

success. It is important to hold what has been learned and get prepared for a new action cycle.

The first two phases worked out very well for both teams. However, the third phase did not work well for the Alfa team. This suggests that an external scenario has influenced the team—the organization's failure to clearly define the team's specific role in the organizational structure. Despite having addressed items 1 and 2 above, the Alpha team's overall objective is not clear and they will not produce a high performance without one, despite being motivated, oriented, and confident.

## 6. DISCUSSION

Besides the characteristics described above, it is important to consider critical success factors for a virtual team in order to maximise the potential for optimal performance.

- The company should select adequate technology to support the virtual teams. It must make sure that this technology works when it is required, because virtual teams depend on it to develop their projects. In the case of *Effem Brasil*, this factor is not critical because the company supplies all the necessary technology, such as e-mail, intranet, video-conference, telephone and instant-messaging.
- It is desirable to provide training for the leaders and members of the teams not only in the use of technology, but also in facilitation skills, project management and the use of tools for conducting meetings.
- The team leader has a fundamental role in the good performance of the team. That is why it is important to provide this person with the necessary tools and skills. The leader should have excellent communication skills, set expectations, allocate resources, and model necessary behaviours. The organization we studied has been successful in accomplishing the work in development and formation, not only of the leaders, but also of the individual team members.

From the present study, it is possible to make the above recommendations to the company, leaders and team members. *Effem Brasil* has more virtual teams than traditional ones in their structure. The company's culture suggests this organizational model, because their members must develop projects with people from other parts of the country. It is necessary that the company starts to consider the characteristics of its virtual teams mentioned in this study in order to make their work easier and to foster better corporate results.

## REFERENCES

- Drexler, S. (1995). *Teams' development*. San Francisco: Jossey-Bass.
- Duarte, D. L., & Snyder, N. T. (1999). *Mastering Virtual Teams: strategies, tools and techniques that succeed*. San Francisco: Jossey-Bass.
- Lipnack, J., & Stamps, J. (1999). Virtual teams: the new way to work. *Strategy & Leadership*, 17(1), 14-19.
- Scholtes, P. R. (1992). *Times da Qualidade: como usar equipes para melhorar a qualidade*. Rio de Janeiro: Qualitymark.
- Zimmer, M. V. (2001) *Criação de Conhecimento em Equipes Virtuais: Um Estudo de Caso em Empresa do Setor de Alta Tecnologia*. Dissertação. Porto Alegre, Departamento de Ciências Administrativas, UFRGS.

## BIOGRAPHY

Marina Keiko Nakayama is a professor at the Business School at the Universidade Federal do Rio Grande do Sul. Michelle d'Ávila M. Matoso is an undergraduate student at the same university. Ricardo Azambuja Silveira is a professor of Computer Science at the Universidade Federal de Pelotas. Their research interests are in the design and use of virtual relationships, e-learning, and distance education in Human Resource Development.

## ACKNOWLEDGEMENTS

This research is supported by grants from the Brazilian research agencies: CAPES - Coordenação de Aperfeiçoamento de pessoal de Nível Superior, CNPq - Conselho Nacional de Desenvolvimento Científico e Tecnológico and FAPERGS - Fundação de Amparo a Pesquisa do Rio Grande do Sul.





## **SECTION 4: COLLABORATION**

# MANAGING DISTRIBUTED UNIVERSITY COURSES

Kirsti Ala-Mutka and Sanna-Maria Räisänen

*Tampere University of Technology, Institute of Software Systems*

**Abstract:** The Open Source Courseware project (OSCu) is aimed at cooperative course development and implementation in university software-engineering education. Open materials and a distributed course implementation model offer effective means for knowledge sharing between universities. However, in practice there are many difficulties in managing distributed courses and the actual cooperation scheme. This article presents the major problems faced in the first four distributed courses, and the approaches that were developed and which are now used to deal with them.

**Key words:** Higher education, experimental, open systems, resources, distributed courses

## 1. INTRODUCTION

Software-engineering education in universities often faces a lack of teaching personnel because of the large number of students and the large scope covered by its constituent teaching subjects. Further, the whole field of software-engineering is constantly developing and courses need to be continuously updated, and new ones created, in order for the university to be able to provide an up-to-date education that develops requisite professional knowledge in its software-engineering graduates. These problems led to a cross-university cooperative project to find solutions to them. The Open Source Courseware (OSCu) project lets universities share the work of developing courses and thus more easily increase the number of different courses for students. Courses are also implemented by distributing tutoring materials among all participating universities.

This paper describes experiences and problems that have been met during these courses and the practices that have been developed to deal with the

problems. Section 2 introduces briefly the principles of the Open Source Courseware Project. Section 3 presents the most important experiences and problems that have been faced in managing the project. Section 4 presents the practices and solutions that have been planned and implemented to improve the working practices in the project.

## **2. THE OPEN SOURCE COURSEWARE PROJECT**

The OSCu project consists of two major components, a course material bank and a distributed course implementation model for the concurrent use of course materials by several universities at the same time. Individual course material production and development is also encouraged. The aim is to pursue university course development practices that are similar to those in the open source software development environment, so that anyone can further develop existing solutions.

It is not uncommon to publish course materials so as to make them available for others. Many universities have been doing this for years in their course web pages. Currently, there are several initiatives that produce and deliver course materials and packages both for contact education and web-based learning solutions, e.g. MIT OpenCourseWare (MIT, 2003) and UNIVERSAL (UNIVERSAL, 2003). The goals of the OSCu materials are, however, more extensive. The project aims to provide enough information for another teacher to really take the course, teach it to students, and develop it further. The teaching materials are equipped with documents regarding their intended use, experiences, and feedback received from the course as well as metadata descriptions of the contents.

However well-documented the materials are, they may still not contain enough information for a teacher who is unfamiliar with the subject or has never seen the materials in use. For this reason, a distributed course model was developed to offer universities the possibility to become acquainted with the issues related to the course in practice. In this model, one university is responsible for designing the course, developing and updating the materials for it, controlling the progress of the course and implementing the lectures via videoconferencing for all universities. The remote universities have local tutoring assistants to take care of the local organizing issues, exercise sessions, and all tutoring tasks for their students.

With this model, remote universities can offer their students courses that they could not have developed themselves. The local tutoring assistant receives the teaching materials and instructions for the teaching situation from the organizing university. After a few years of participating in a course in this fashion, the assistant has enough knowledge for organizing the course

by her/himself. In this way, students and teachers at the remote universities get new knowledge and the lecturer at the organizing university receives versatile feedback for developing the course in the future. With well-documented materials, it is also possible to transfer courses between universities so that the materials get updated and improved also by other persons than the original creators.

The project organization has two levels. The executive group consists of representatives from all the universities in the project and its main task is to decide the guidelines and funding issues for the project. Each course is a subproject, managed by the organizing university. The organizing university is responsible for all the issues related to the general organizing, designing, and implementation of the course. Remote universities are responsible for carrying out their part of the tutoring, reporting, and feedback collection according to the given instructions. The OSCu project coordinator develops guidelines and ensures that all the actors have a correct understanding of the project goals and guidelines and of their tasks on the courses.

More information on the project ideas, technical implementation, and experiences can be found in Ala-Mutka & Mikkonen (2002).

### **3. PROBLEMS IN IMPLEMENTING DISTRIBUTED COURSES**

During the first year of the project, three universities organized altogether four courses, all of them having two participating universities. Since the easiest way to introduce new kinds of teaching models is to create new courses, the course topics were selected so that each university presented a course that was not on the curriculum of the other universities. This demonstrated well the sharing and delivering of new knowledge, but also created many practical problems.

One of the big problems with distributing education for different persons is ensuring the same level of tutoring and guidance for all students. With new courses, the problem becomes magnified if the tutoring assistant in the other university does not have much previous knowledge of the topic. She/he may also lose interest in the tutoring task if she/he does not feel well enough prepared for the task.

Another problem stems from the lecture arrangements. If some students watch the lecturer on a screen while others have her/him present, it is clear that they have a different experience. If the lecture's teaching style and the local tutoring assistant are not activating the remote students, the latter may feel they are just watching a TV show with no motivation to really

concentrate on the issue. Also technical problems bother remote students more than local ones.

One problem was the lack of understanding of the larger goals of the project and thus lack of motivation among the teaching personnel to follow the given guidelines for course practice. Some teachers did not see their work as much more than dealing with their local student group and were not motivated to participate in or implement coordinating actions with others. This caused problems of course uniformity and was also seen in the final examination results, where the differences between local students' grades and the remote students' grades were obvious on some of the courses.

There were often problems in preparing the practical matters for the courses. Information on some relevant issues was decided or communicated to the participating universities so late that all the course arrangements could not be implemented in time or at all. There were problems with e.g. differing lecture periods, lecturing times, the software platform for coursework, and communication practices on the course. Also unclear roles of the teaching personnel often made it difficult to sort out these issues.

Course documentation and materials were archived and documented poorly on many courses and some teaching materials are still missing from the archive. Also the implementation process of courses was sometimes poorly documented, although all lecturers agreed to document their course according to the given precise guidelines. Sometimes also the assistants did not receive enough instructions for their work, and thus the lecturer had to do some tutoring and evaluation work by her/himself for all the universities.

These problems also led to the new challenge of organizing the coordination in the future with a larger number of participating universities. The project coordinator had to spend a lot of time ensuring that course lecturers and universities organizing a course completed their tasks as well as necessary. When continued this way, for every new 5 universities and courses a new coordinator is needed to make sure that the universities and teachers are aware of and motivated to take care of all their tasks.

#### **4. IMPROVING THE PRACTICES**

For managing a course that is distributed to several universities and persons, it is very important to have a common understanding of the goals and the work to be done. Like in a multi-site software project, this requires careful planning, documentation, and continuous communication between all the project partners. However, all the persons in the project do not necessarily see the relevance of the strictly defined guidelines or the additional tasks, compared with their normal tutoring work. For this reason,

the guidelines were refined and new ones were created to motivate and offer information on each teacher's role in the project.

A balanced distribution of actions and responsibilities with well-defined practices for all the participating universities is required for this kind of activity to stabilize as a part of normal university education. For this reason, the project practices are being developed toward a model in which only minimum central coordination is needed. Most of the course-related work is already financed with participating universities' own resources, which makes it easier to change later to completely self-financed operation.

## **4.1 Course level management**

One of the big problems in the courses was lack of clarity with personal responsibilities. The working model was new for most of the course teachers and they could not comprehend all the tasks required of them. To make these issues clear, the coordinator created instructions of the course actor roles and the tasks belonging to them for both organizing and remote universities. These instructions list all the main tasks that are required in carrying out a distributed course, e.g. by a "lecturer" or by a "remote lecture assistant".

One of the main problems was the coordination of the course, partly due to the unclear tasks and roles and partly because these tasks were distributed between many persons. For more structured management and less work for the organizing university, each university partner on the course is now required to assign a "coursemaster" who is responsible for the local arrangements of the course. She/he is the contact person in all course-related matters and delivers information and tasks forward to the organizing university or to the local tutoring assistants as she/he sees necessary.

Designing and organizing a course involves plenty of work in itself and the experience has shown that a lecturing professor seldom has time for any extra work. For this reason, we suggested that in every OSCu course the coursemaster at the organizing university should also take care of all the OSCu project-related extra work issues on the course. Thus, she/he should take care of the most of the coordination issues, course material archiving, and metadata descriptions. The lecturer can concentrate on designing a course and methods of teaching it, and his workload does not increase significantly due to the distributed course implementation. This is especially important on new courses, where the contents and materials are created from scratch, which requires lots of time for material development.

For improving internal course communication, weekly meetings and opening and closing seminars for the whole course personnel are now required for all courses. To ensure that all necessary issues are covered for these situations, the coordinator has provided general agenda suggestions.

There are also guidelines for organizing communication outside the meetings through course masters. This provides the fastest answers regarding local issues and gives students and local tutoring assistants a dedicated contact person for problem situations with time to answer questions.

## **4.2 Project level coordination and control**

All of the project's instructions and guidelines are documented in written form and made available to all OSCu partners. This is important for communicating the practices pursued in the project, and to make them clear to all participating personnel. The coordinator actively follows and evaluates courses and gathers information and experiences to continuously improve these instructions. There are guidelines e.g. for planning and acting in videoconference situations, for course organizational issues, for documenting course materials, and for reporting course implementation.

Many of these documents were available when the courses started. However, not all of the course personnel read them well enough, or at all. Subsequently we have implemented a mandatory 1-day orienting seminar for the key people involved in all of the courses - to ensure that they do become familiar with the project's ideas, nature and practices. The coordinator participates in the seminar, providing brief training on the project and its procedures and checking that the personnel addresses all the necessary crucial course issues at the beginning of the course.

Material archiving was the biggest problem on many courses. Particularly in the case of new courses, the creating of the materials was so laborious that the lecturers had no time to document the materials and the course implementation thoroughly. This problem is partly addressed by assigning the material archiving tasks to the coursemaster. Practice has suggested that it also should be monitored during the course. Now the material archiving is required to be completed at least after every 1-credit subunits of a course. It is also recommended that the course archive be published for OSCu partners so that they are able to follow its development. In this way, the materials have to be documented and archived little by little and this work does not pile up at the end of the course.

Preparing a distributed course requires taking care of many small details, especially in the case of new courses. A checklist of all the crucial tasks placed in a timeline was implemented as a tool for all universities that need to prepare for a course. The checklist contains issues like "adjust the lecture periods, inform about the needed software, decide the roles for the course personnel, create course webpages", etc. These tasks cover the main points

that have been noticed to be important from a practical point of view for OSCu course preparation in both the organizing and remote universities.

### **4.3 Motivation**

One of the big problems in implementing courses was that the personnel was not prepared or motivated to do all the tasks expected of them. This was partly due to the fact that they were not that familiar with the whole project and could not understand their part in it. The tasks are now more clearly defined in the instruction guidelines and the motivation problem is approached by the personal visit of the coordinator to the opening seminar for each course. She takes care of introducing the basis and goals of the whole project, explains the need for the specified practices, and emphasizes the importance of each project member in achieving the common goals.

One of the most common demotivating factors in 2002 was the lack of time. OSCu-related issues were often expected to be carried out in addition to the teachers' normal tasks. Therefore, an approximation of the needed working hours was made for each of the personnel roles. The approximation serves two purposes. It clarifies for people in advance how much work they are expected to invest, and it functions as a basis for teachers in negotiating their total workload with the manager of their department.

Another reason for the lack of motivation is that teachers do not know how to prepare themselves for this new different situation with possibly new topics. For this reason, the coordinator has prepared guidelines for the lecture situation with suggestions the student activation. Also, in the course opening seminars and weekly meetings it is suggested that the course personnel always go through the relevant topics on the course so that each tutor obtain enough knowledge and instructions for the local tutoring tasks.

The best way to motivate persons to work in a project is to involve them already in the planning, not just to implement something already decided. During the course, all teachers regularly have a possibility to suggest actions and methods for the course. They could also be offered a possibility to participate to planning the course implementation in advance. For example, distributing course work design to several universities has produced good results regarding the motivation and team spirit of the course personnel.

## **5. CONCLUSION**

This paper has described problems, and approaches for solving them, in the OSCu project and in using its distributed course model. In order to get courses to run smoothly, people have to understand and perform all the tasks



assigned to them. Also internal course communication and cooperation have to function smoothly throughout courses. This is essential in order to be able to provide equally good education for all the students in all the participating universities.

It is very important to motivate all the persons working in the project to see the common goals and the need for common guidelines also in their own work. The working models need to be clear, motivating, and beneficial so that every person and partner university experiences receiving something in return for the work they provide. In the future, the role of the course material bank as an instrument in coordination will be emphasized. When course materials and weekly meeting reports are actively updated for the material bank during a course, the personnel can always be aware of the current situation regarding the course and the tasks expected of them.

The described management practices have shown positive effects on OSCu courses during Spring 2003. The practices are also being implemented and evaluated with a special care on an example course for creating proper working guidelines for the personnel on other courses. Developing the management of distributed courses requires comprehensive feedback from all the participants in the project. In the future, the role of feedback will be more emphasized and gathered systematically from both students and all course personnel in order to ensure continuous development of the practices.

## REFERENCES

- Ala-Mutka, K. & Mikkonen, T. (2002). Experiences with Distributed Open Source Courses. In L. M. Ribeiro & J. Marques dos Santos (Eds.), *The Changing Universities: The Challenge of New Technologies: Proceedings of the 8th International Conference of European University Information Systems (EUNIS 2002)*, (pp. 26-37). Porto: Faculdade de Engenharia da Universidade do Porto
- Massachusetts Institute of Technology. (2003). MIT Open Course Ware. Retrieved 27.8.2003 from <http://ocw.mit.edu/>.
- UNIVERSAL project. (2003). Retrieved 27.8.2003 from <http://www.ist-universal.org/>.

## BIOGRAPHY

Kirsti Ala-Mutka's main research interest is in developing computer based solutions for assessment and learning support in software engineering education. She has also been involved in creating the Open Source Courseware project for improving the quality of courses by developing staff and university cooperation. Sanna-Maria Räsänen has research interests in distance education, learning at work, and human resource management. She has been working as a developer and a coordinator in the Open Source Courseware project.

# ENABLING POSTGRADUATE LEARNING IN THE WORKPLACE

Nicola Beasley<sup>1</sup>, John Ford<sup>2</sup>, and Nils Tomes<sup>2</sup>

<sup>1</sup>*Napier University, Edinburgh, Scotland;* <sup>2</sup>*Heriot-Watt University, Edinburgh, Scotland*

**Abstract:** This paper describes a research project that aimed to determine and evaluate the learning environment customisations required to support self-motivated, able, and experienced learners studying towards a Masters degree in Petroleum Engineering within small to medium-sized enterprises (SMEs). The requirements analysis of the specific needs of workplace learners, the system customisation and evaluation are described. The evaluation showed that organisational factors are a key factor in achievement, that students tended to study sequentially even in a hyperlinked environment, and that they valued a combination of online and printed materials.

**Key words:** distance learning, computer assisted instruction, higher education

## 1. INTRODUCTION

An online study environment can be an effective medium for self-motivated students to study at work (Gray, 1999; Brink et al., 2002; Harun, 2002). This paper describes how a learning environment can be developed to support this type of independent learning. The EC-funded CBLPET (Computer-Based Learning in Petroleum Engineering) project, described here, builds on previous research in the development of constructivist learning environments (Grabinger & Dunlap, 1995; Hannafin & Land, 1997; Jonassen & Murphy, 1999) and computer-based learning for skills-based training (Ferreira et al., 1998) to identify possible customisations for an online learning environment that could support Masters-level, workplace-based students of Petroleum Engineering, and to evaluate the effectiveness of that environment.

The project aimed first to define the ways in which the learning requirements for postgraduate, workplace-based students differ from the requirements of lower-stage, campus-based students, and to design a learning environment taking this into account. The second aim was to evaluate the effectiveness of this learning environment.

In the sections that follow, the project is described in more detail; the process of eliciting the user requirements is explained; the evaluation methodology is specified; the evaluation results described; and finally, conclusions are drawn from the research.

## **2. DESCRIPTION OF PROJECT**

The development of the CBLPET learning environment was primarily based on previous research in the design of online learning environments undertaken in the EU-sponsored ASTEP (Advanced Software for the Teaching and Evaluation of Processes) Project (MacKinnon et al., 1998). ASTEP differs from CBLPET in that it focuses on process-based technical training, so the first stage of this project was to perform an evaluation of which elements from the ASTEP framework were appropriate for the new learning environment, and which additional elements would need to be added to meet the specific needs of the degree, student group and industry.

The Masters degree in Petroleum Engineering is a one-year, intensive, highly demanding campus-based course, which is also available as a paper-based distance learning course, aimed at graduate engineers. The student population being studied were undertaking study while working in the Petroleum Engineering industry, came from a range of nationalities, and had a broad range of graduate-level scientific and technical knowledge.

The petroleum industry is international with a highly mobile workforce. Not only do students reside across the globe, they may be expected to move location at short notice; therefore an environment that allows continuity of study is of prime importance. Workers require up-to-date multidisciplinary skills to stay employable in a quickly changing market, and a significant proportion of the workforce are based in small to medium-sized enterprises, with heavy demands on their time, and where there are often no subject experts locally available. SMEs are also characterised by having small training budgets and limited release time for staff (Bradley & Oliver, 2002) and these factors reinforce the efficacy of online learning.

The requirements analysis for this project was based on a series of interviews, questionnaires, and an industry analysis. This was followed by the production of a prototype online environment containing two of the MSc course modules in web format, which were used by students to study for the

relevant examinations. The final stage of the project was to conduct an evaluation of the system to assess its effectiveness and draw out a set of recommendations for further research and development.

It was hypothesised that online learning would significantly enhance the availability, affordability and flexibility of advanced training while delivering the essential quality of learning needed at this level.

### **3. ELICITATION OF REQUIREMENTS**

The purpose of the requirements analysis was to identify elements of the ASTEP environment that would be appropriate for the student population under study, and additions that could be made to the existing learning environment to make it more suitable for workplace-based MSc students.

The ASTEP framework is a task-centred model for development of learning environments, which includes thirteen recommendations for technical components, covering the areas of student management, assessment, student portfolios, communication, online identity, activities, materials and evaluation. As it is a model designed for teaching processes face-to-face, some components – portfolios, synchronous communication, process diagnosis activities – were not seen as appropriate for this project; however, the framework provided a good basis on which to begin.

The requirements analysis consisted of three stages: collection of data from students, mentors, academic, technical and managerial staff, using questionnaires and interviews; a market analysis of the small to medium-sized enterprise segment of the petroleum engineering market; and an evaluation of the ASTEP framework in relation to these results.

These analyses provided a number of requirements for workplace learners, many of which were commonly accepted constructivist learning environment components such as learning activities, setting learning within an authentic context, provision of information resources (Grabinger & Dunlap, 1995; Jonassen & Murphy, 1999) and are therefore not discussed further here. There follows a discussion of the key additional features implemented, which the analysis indicated would be of value in supporting mature, work-based learners in petroleum engineering.

Four key features to support these learners were identified in the requirements analysis. First, although communication systems are a basic feature of many constructivist learning environments, they are highlighted here for a number of reasons. Students on the course are geographically dispersed, working in small organisations with no subject specialist readily available, so it was considered that an effective way of communicating with academics, and other students on the course, was of prime importance. The

use of a synchronous communication system was not thought to be appropriate, owing to international time differences, so this need was met using an asynchronous discussion forum.

Secondly, it was considered that a way of storing user data to personalise the system and store data regarding tasks completed was essential because students may not be working in fixed locations and would still need to see where they are in the materials and what work needs to be completed.

Thirdly, students come from diverse undergraduate backgrounds and it is common for many to experience difficulty with those modules on the course that contain new technical terminology and a large subject vocabulary, particularly students whose first language is not English. There was therefore a requirement for an easily accessible system for displaying terminology, which was implemented using an extensive hyperlinked glossary.

Finally, on the technical aspects of delivery, since students are based in locations worldwide, it is essential to use technology that is available to all. Also, students studying at work may not have exclusive access to a computer, and may not have permission to modify the set-up. For this reason plug-ins and use of machine customisations were kept to a minimum.

Students were supported on a day-to-day basis by company mentors and managers, as well as academic and technical staff at Heriot-Watt University.

The evaluation focused on those features which, on the basis of the discussion above, it was expected would add particular value to the target users, as well as examining the ways in which the environment was used by students, and identifying improvements for future iterations of the course.

#### **4. EVALUATION METHODOLOGY**

The aims of the evaluation were to identify which requirements were adequately met, and which needed further research and development; to discover how the learning environment was being used in an organisational setting; and to catalogue ideas and suggestions for future improvements. Two student groups took part in the evaluation of the prototype modules:

- Distance learning students enrolled on the course and using paper-based materials while studying at work were offered access to the online system and 18 students agreed to take part in the evaluation. They were asked to complete a questionnaire detailing their first impressions after three weeks (12 returns) and to complete a second, in-depth questionnaire after completing the course (4 returns). While the response rate from the second questionnaire was disappointing, the questionnaires that were completed were thorough and insightful.

- Two small-to-medium-sized petroleum-engineering companies (in Scotland and Norway) were selected to take part in this study, and each company put forward two individuals who were interested in studying online. These individuals took part in an in-depth evaluation involving interviews and walkthroughs of common tasks within the system.

It is interesting to note that despite initial interest from 18 distance-learning students, only 12 actually accessed the system. Where reasons for this were given they tended to focus on lack of free time, and the fact that students were already used to working with the paper manuals.

In addition to the evaluations completed with students, interviews were carried out with company mentors, academic, managerial, and technical staff who had been using the system to support students.

## **5. EVALUATION RESULTS**

The prototype system was received positively by the vast majority of students that used it; they appreciated its simple usable interface, ease of navigation and appropriate content.

Initially, students were provided only with access to the online materials but they asked to be provided with printed copies of the materials too. The students appreciated the flexibility of working without a computer that access to paper copies of materials afforded them. Although the students involved in the trial were allowed to study at work they were actively encouraged to work at home in their own time, and, in fact, most students worked predominantly with the paper copy at home, and with the computer-based materials at work. This preference for working on paper has also been found in similar studies (Crook, 1997; Ward & Newlands, 1998). The evaluation showed that most students found that studying at work during working hours was difficult owing to constant noise, interruptions, and large amounts of time spent away from the desk, and most favoured working at home or in the office, out of hours. The inability to annotate the web-based material was also cited as a reason for preferring to work on paper.

A suggestion for improving the ability to study in the workplace would be the provision of approximate timings for topics and activities. Students noted that when studying in the workplace they often had definite time periods in which to study; it was therefore suggested that timed 'lessons' of different lengths would be very beneficial in enabling workplace study. There was a marked difference between the performances of the students studying at the Scottish company compared to those at the Norwegian one. The evaluation indicated that this was due to the increased sense of isolation felt by the Norwegian students.

An asynchronous discussion forum was provided for students to ask subject-specific questions of the university-based academic staff, but was used by few of the students. The main reason was that they genuinely saw no need for such a feature as they could gain all the support they needed from the company mentor and preferred to get that support face-to-face, although some students were discouraged by the lack of activity on the forum.

A personalised reporting system was also provided for students to monitor their progress through the materials and identify which sections they had yet to finish, and this was also universally unused by the students as they felt they had no need for such functionality. The students tended to study in a linear fashion rather than by following hyperlinks so it was obvious to them which sections still had to be completed. However, academic staff found this feature useful for monitoring student work patterns and progress.

The use of a hyperlinked glossary system was found to be extremely useful by all students, although there were some technical issues with download times over slow connections. The ability to use a glossary term to look up its references in the accompanying text was cited by several students as a worthwhile future improvement.

The fact that simple technology was used was approved by most students, who appreciated the speed with which the site functioned. The students preferred a fast and functional system to a slow and fancy one. There were few technical issues associated with accessing and using the site.

An interesting finding was the way in which students used the learning activities embedded in the course, which consisted of self-test questions, worked examples, and reflective activities. The online system is designed in such a way that activities can be used to support learning in two ways – to consolidate learning after studying sections of the material, or to act as a structure in itself, using the activities to guide learning. Students indicated that they felt these activities were a core part of the course, but they were used exclusively in the former context. Learners preferred to study in a linear fashion, using the materials as a basis from which to access the activities. An interesting consideration for further study is whether this is due to a true preference for linear study, a preference for paper-based materials and a need to use the online materials in conjunction, or simply a lack of experience and support in non-linear forms of learning.

Interactive course elements, although identified in the requirements analysis, were not prioritised in the prototype system. However, a section of the evaluation focused on the areas of the course where appropriate interactions could best add value, and what those types of interactions should be. Suggestions that are particularly appropriate to the target group include:

- glossary word-matching quick quizzes to test knowledge in areas that depend on knowing a lot of terminology;

- animated graphics of geological and time-dependent processes;
- the ability to isolate separate data segments on complex graphs;
- hints, such as bringing up a solution to a problem a line at a time, so that keen learners can pick up the problem from where they understand it.

## **6. CONCLUSIONS**

The evaluation conducted in this study highlighted a number of findings for further research, and suggested several key improvements that would help to improve postgraduate workplace learning in petroleum engineering.

A main issue associated with workplace learning is that of balancing study and work time as well as dealing with noise and distractions. Managerial and mentor support is key to successful study at work. The restructuring of the course into timed lessons, which can be scheduled into the working day, would enable students to better plan their workloads.

Students worked with both paper-based and online materials showing a preference for paper-based outside the workplace, and it is evident that in the petroleum engineering industry a mixed model of home and workplace, paper-based and online delivery is required. It is apparent that online learning should not be seen as a replacement for the printed study guides currently used in the Masters course in Petroleum Engineering, but should be used strategically to complement and support them by providing appropriate communication facilities, hyperlinked glossaries, Internet links to information, interactivities, and online formative assessment. Students tended to work through the materials in a linear rather than hyperlinked fashion, using activities to support the materials and not vice versa.

Further investigation in this area would be useful to try to identify the reasons this might be so. Other potential areas of research include a study of the key factors that lead to isolation and how a learning environment could be used to counter them, and an investigation of ways in which to practically counteract the barriers to students using the online materials in the workplace. In all, this study has shown that an online learning environment – in combination with paper-based resources – can be an effective medium for postgraduate workplace learning. However, issues such as student isolation, improved use of the potential of the web through increased interactivity and communication, and organisational support need to be addressed in future developments.



## REFERENCES

- Bradley, C. & Oliver, M. (2002). Developing e-learning courses for work-based learning. *Paper presented at the Eleventh International World Wide Web Conference, Hawaii*. [Available online] <http://www2002.org/CDROM/alternate/703/>
- Brink, B., Munro, J. & Osborne, M. (2002). Online Learning Technology in an SME Web-Based Setting. *Educational Technology and Society*, 5(2), 81–85.
- Crook, C. K. (1997). Making hypertext lecture notes more interactive: undergraduate reactions. *Journal of Computer Assisted Learning*, 13, 236–244.
- Ferreira, M., MacKinnon, L., Desmulliez, M. & Foulk, P. (1998). A multimedia telematics network for on-the-job training, tutoring and assessment. *Proceedings of the International Conference on Engineering Education, Rio de Janeiro*.
- Gray, D. (1999). Work-based Learning, Action Learning and the Virtual Paradigm. *Paper presented at the European Conference on Educational Research, Lahti, Finland*.
- Hannafin, M. J. & Land, S. M. (1997). The foundations and assumptions of technology-enhanced student-centered learning environments. *Instructional Science*, 25, 167–202.
- Harun, M. H. (2002). Integrating e-Learning into the workplace. *The Internet and Higher Education*, 4, 301–310.
- Jonassen, D. H. & Murphy, L. (1999). Activity Theory as a Framework for Designing Constructivist Learning Environments. *Educational Technology, Research and Development*, 47(1), 61–79.
- Grabinger, R. S. & Dunlap, J. C. (1995). Rich environments for active learning: a definition. *ALT-J*, 3(2), 5–34.
- MacKinnon, L. M., McAndrew, P. & Flockhart, S. (1998). ASTEP Framework User Manual. [Available online] <http://www.cee.hw.ac.uk/~astep/deliverables/d24v12.pdf>
- Ward, M. & Newlands, D. (1998). Use of the Web in undergraduate teaching. *Computers & Education*, 1, 171–184.

## BIOGRAPHY

Nicola Beasley is an Academic Development Adviser at Napier University. She has worked in the research and development of online learning systems for several years, key areas of interest being the design of learning environments and use of online activities. Recent research includes the use of educational games with adult learners. Dr John Ford is a Senior Lecturer in the Institute of Petroleum Engineering at Heriot-Watt University. His research focuses on the area of Drilling Engineering but he has also initiated studies on the use of novel techniques in the delivery of Masters-level and professional development courses. Dr Nils Tomes is Director e-Networks and Communities for the British Council. She was Director of Learning Technology at Heriot-Watt University and developed a national online programme for post-compulsory education. This programme is now in use by science, maths and language pupils within all education authorities in Scotland and is being adopted in England, Southeast Asia and Southern Asia.

# **A BETTER E-TRAIN**

## *Program Quality Assurance and University E-Training*

Bill Davey<sup>1</sup> and Arthur Tatnall<sup>2</sup>

<sup>1</sup> *School of Information Technology, RMIT University, Australia,* <sup>2</sup> *School of Information Systems, Victoria University, Australia*

**Abstract:** This paper describes a system of Program Quality Assurance that has acted to improve the quality of e-training programs in an Australian university. It is based on the use of quality cycles, and was devised to enhance the quality of all of the university's programs. This paper is based on research involving interviews with stakeholders in this system and, amongst other things, uncovered some mistakes that had been made in the initial systems implementation that resulted in a number of academic staff distrusting the system. The paper suggests that better training could have reduced these problems. It argues that the use of this system, despite these implementation problems, has been seen by most stakeholders as an important contributor to improving the quality of e-training systems, rather than just measuring them.

**Key words:** Higher education, industry practices, quality, curriculum development.

## **1. INTRODUCTION**

The multimedia facilities of e-training tools can produce a system that looks impressive, but does not necessarily perform in the field. As universities have embraced e-training tools, the need to ensure quality of electronically delivered material is of increasing importance. In Australia, measurement has been mandated by funding bodies, so a study was made of some attempts to perform this measurement in an environment rich in electronic delivery. Of the universities studied, one was found to be particularly effective not so much in measuring quality as in improving it. This paper details outcomes of this program.

In 1993 the University introduced Program Quality Assurance (PQA) to ensure continuous improvement in all programs. While electronically

delivered or augmented programs were not present in any quantity at the time of its development, the system is now also used to improve their quality. It was set up to demonstrate educational accountability, and also in a genuine attempt to make teaching and learning better (Bowden 1997). Its designers insisted that the system was based in educational theory and that 'the approach that the University has taken to educational quality assurance has been to attempt to achieve an appropriate balance between the improvement and accountability aspects of quality assurance...' (Bowden, 1997 p2).

It could not, however, be said that its introduction was without controversy among the academic staff. In hindsight, some implementation mistakes were made, and some aspects of the system did not work as well as they should have. A lack of suitable staff training was one reason for these problems (Matthews, Ueno, Periera, Silva, Kekal and Repka 2001).

In this paper we will, however, argue that the system has some major advantages and that it serves well the goal of continuous improvement in educational quality, particular in relation to those programs involving e-training.

## **2. E-TRAINING AT THE UNIVERSITY**

The University has both a standard authoring tool (WebCT) and an infrastructure product to support delivery. Infrastructure support uses Distributed Learning System (DLS) that consists of a suite of common products including BlackBoard, WebBoard and similar products together with a range of diagnostic and communication tools to allow online testing, chat and normal facilitated communications. All of the programs and almost all of the courses are represented on the DLS, meaning that academic content developers are required to work through the system at least as far as description of their courses.

The University also offers most of its programs overseas (Marginson 2002), particularly in parts of Asia, in addition to its local offerings. This usually involves an offshore partner providing facilities, with the program being delivered by visiting lecturers, supported by technology. An Australian lecturer typically visits the students for a week or so, and then they are supported electronically for the remainder of the time. The University is a member of two co-operative programs: the Global University Alliance and Open Learning Australia in both of which the University delivers units that are taken completely online. Units are also delivered by other university partners so that a student can make up a whole program from amongst these offerings. Some undergraduate and postgraduate degrees

are offered *completely* online through several strategic programs. While comparatively small in enrolments at the moment, some of these programs have been offered for several years.

When development of the system of PQA started in the early 1990s it was described as Educational Quality Assurance (EQA). We will not delve too far here into what might have been meant by educational quality by those developing the system (Vidovich, Fourie, van der Westhuizen, Alt and Holtzhausen 2000; Gilroy, Long, Rangelcroft and Tricker 2001), except to say that it was seen to relate to ensuring that course documentation reflected practice and assisted in the improvement of practice.

A proposal by Bowden and Knowles (1994) resulted in the University setting up Educational Quality Audit Committee, and adopting an EQA system which had seven key elements. Their focus has been described by Bowden (1997) as follows:

- The focus is on educational programme (degree course) teams working together to continually improve the quality of teaching and learning and taking responsibility for that quality and its evaluation.
- Course Teams are expected to engage in continual improvement of student learning experiences and learning outcomes through attention to teaching, curriculum, assessment and course management issues.
- The continual improvement processes and their outcomes are fully documented for each course in an Educational Quality (EQ) Log.
- Summaries of each EQ Log document are recorded on a centralised Educational Programme Quality Management computer file developed for the purpose; this file also contains student performance data and is used to monitor quality improvement processes within each course so timely support can be given in a targeted fashion.
- Each course is audited once every five years.

The quality assurance processes are intended to be linked to the University's strategic planning, performance and academic promotion procedures to minimise duplication of effort by academic staff. This process has become more coherent since adoption by Academic Board of a University Teaching and Learning Strategy." (Bowden 1997).

### **3. THE PROGRAM QUALITY ASSURANCE SYSTEM**

Program Leaders co-ordinate each Program Team comprising the academic staff that teach and are responsible for each program. They play an important role in the PQA system as they need to facilitate Program Team participation in PQA planning, review and renewal and are responsible for

collecting input from members of the Program Team relating to student feedback, and ensuring that all program documentation is collected as part of the Program Log. The Program Log is maintained to ensure that all program documentation is kept in a form that assists Program Team effectiveness and provides evidence of the success of the program. It is updated through the Program Quality Management system (PQM), which provides central access to all relevant information so that it is readily available to all stakeholders in the University. It is intended that it be used as a resource for academic and administrative staff, to provide background information for course or program re-writes, as a frame for ongoing program review and to assist preparation of program assessments and accreditation.

An important aspect of the PQA system is the program improvement process, and this, in common with other quality systems (Williams 2002) is based on the concept of continuous improvement cycles which are “planned sequences of systematic and documented activities aimed at improving student learning and the quality and relevance of the program overall” (RMIT 2002). These activities include reflection, decision making, implementation, monitoring and feedback, and evaluation. The continuous improvement cycle can be pictured as shown in Figure 1 below.

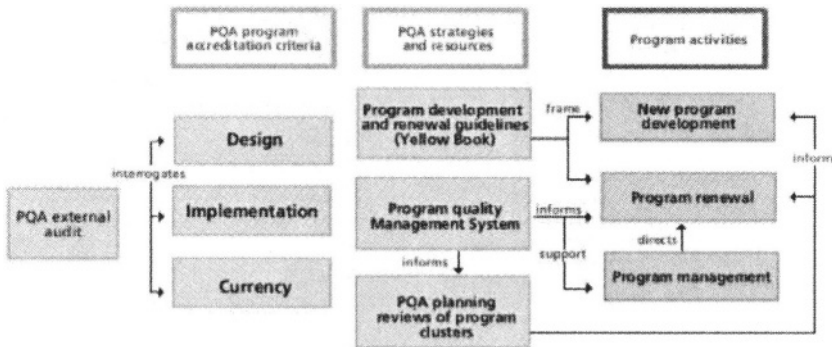

Figure 1. Continuous improvement cycle (RMIT 2002)

#### 4. HOW THE PQA SYSTEM WAS ANALYSED

In this investigation the authors conducted a series of semi-structured case study interviews with a sample of teaching academics, Course Co-ordinators, PQA reviewers, and personnel involved in the planning and

implementation of the PQA system. Interviews were tape-recorded and interviewees were later given a chance to make any corrections they thought necessary to the final manuscripts. Participants were questioned about how the PQA system affected their work, what they thought of the system, what they thought it might achieve in improving educational quality—especially that relating to e-training—and any implementation or other issues with the system that concerned them (Davey and Tatnall 2003). Published papers on the topics of EQA and PQA and appropriate system documentation (Tatnall and Davey 1997) were also used to complete the case study.

#### **4.1 Why Quality Improvement not Measurement?**

Funding bodies have a right to demand accountability for the funds they spend in education and training institutions. This accountability focuses on outcomes, which are fairly simple to measure. It is not so simple improve training performance. The managers of quality systems took the view that quality improvement must come from responding to information regarding problems or opportunities with individual programs rather than an overall single aim. Many alternatives studied at other institutions involved simple exit surveys and the like that were difficult to interpret in terms of decisions that could be made with a program. Questions such as ‘were you happy with your course?’ might get to the issue of satisfaction but seldom pointed out what directions a provider team might take in terms of improving delivery.

Program leaders reported many improvement cycles that could not have come from examination of participant responses. Major issues such as documenting changes to a course and the reasons for change enabled a very mobile workforce to be in tune with the team’s intended directions.

#### **4.2 Perceived Problems with Global e-Training**

Some administrators of institutions involved in e-training seem to carry a model of e-training that involves a static repository of knowledge with an increasingly effective e-delivery mechanism. The institution studied shows a richer and more complex pattern, particularly in a global context.

The everyday quality problems in this large provider include:

- delivery to multiple locations in multiple countries,
- each location serviced by a different administrator and contract,
- rapid and continuous change in content forced by technology leaps,
- widely divergent learner educational and cultural differences.

Each of these factors produces quality problems that must be addressed. These problems are specific to programs and produce symptoms of a

pressing nature that preclude solutions as simple as surveying students for perceived quality deficiencies.

### **4.3 Response to the PQA from e-Training Specialists**

The PQA is predicated on recording quality cycles starting with identification of a problem or opportunity and involving responses with measurable effects and a review of effectiveness. These cycles are built from the course planning teams. This ‘grass roots’ identification of quality improvement opportunities was found to be a mixed blessing. People responded with positive comments about the relevance of quality cycles they had implemented, especially in comparison with imposed systems. They also found that work involved with recording the cycles was onerous. This was particularly evident when comparing members of delivery teams that had been stable over a number of semesters as opposed to new teams. The ‘pay back’ of PQA for stable teams was often seen as being less than effort expended. For new teams, ability to see what had happened to improve courses enabled them to avoid ‘reinventing the wheel’.

### **4.4 Implementation Mistakes**

Despite time spent by system developers in speaking with groups from each Faculty, some academic staff either did not understand, or did not trust the University in what was being proposed. It can be expected that some academic teaching staff used to working in traditional roles should be anxious about jobs in an e-training environment (Starr 2001). At the University, a number of academic staff still see the PQA system as an attempt to regulate and stifle professional freedom in course design and teaching. Given the size of the institution, the diversity of its staff, and the implementation mistakes described above, this view is understandable. Current use of the system does not support this view.

It could be argued that with the benefit of hindsight, and of more time to stage the implementation, better change management measures could have been introduced. An Institute of Management survey conducted by Wilkinson et al. (1993) found a strong relationship between an individual’s assessment of the adequacy of training and the reported degree of success of the quality management program. Whether or not more time or better training would have convinced all academic staff of the benefits of the new system is unclear but, with hindsight, perhaps more could have been done to convince those academics who were still doubtful. Another criticism is the time needed to document activities.

## 4.5 Responding to the unique problems of e-Training

It is easy to make the mistake of thinking of an e-training package as 'finished', and as a consumer package that can be delivered without revision. In every case studied it was found that changing markets, changes in content forced by new discoveries and problems with delivery forced continuous change in e-training 'packages'. The philosophy of documenting progress rather than measuring current parameters of output seems well suited to the task of delivery by large teams to very large groups of widely distributed students. The University has found that continuous change is the only way of improving e-training, and that the direction of change and improvement is best left to intellectual property producers and deliverers. To ensure accountability merely requires a properly functioning PQA system.

## 5. CONCLUSION

Quality education is a difficult concept to define, and this leads to problems with measurements related to quality. A useful view of quality of e-training is to question: 'What can we do to improve quality?' rather than the question 'How much quality do we have?' The case study was of an organisation that focused on the former question rather than the latter. The PQA is designed around identifying problems with quality, or opportunities for improvement, documenting them and reviewing success of responses. This approach entirely avoids the issue of benchmarking a particular program, but involves the delivery team in proposing and implementing improvements based on real evidence. The case study showed significant advantages of this approach in involving the Teams in quality issues. The case study showed that, even with a system based on Teams, imposition of a system from above was resisted by many academics. The case study also indicated that e-training quality is a complex topic with many levels of difficulty that affect the end product. These include writing and delivery teams, the nature of very different audiences and the fast pace of environment change. Although not the focus of this study, respondents often mentioned dissatisfaction with generalised, measurement-based quality control systems.

## REFERENCES

- Bowden, J. (1997). Continual Quality Improvement in Learning and Teaching through a Centralised Approach to Educational Quality Assurance. *Managing the Quality of*



- University Learning and Teaching*. Bowden, J. & Sacks J. <http://www.deetya.gov.au/divisions/hed/operations/Bowden/chapter8.htm#head1>, (June 20), Higher Education Division, Department of Employment, Education, Training and Youth Affairs.
- Bowden, J. & Knowles, D. (1994). A Proposal to Academic Board for a System of New Course Approval, Course Discontinuance, Course Re-Accreditation and Quality Assurance. Melbourne, RMIT.
- Davey, B. & Tatnall, A. (2003). Improving Distance Education through Program Quality Assurance. in E. Stacey & G. Davies (Eds.), *Quality Education @ a Distance*. Geelong, Deakin University.
- Gilroy, P., Long, P., Rangecroft, M. & Tricker, T. (2001). Evaluation and the Invisible Student: Theories, Practice and Problems in Evaluating Distance Education Provision. *Quality Assurance in Education* 9(1), 14-22.
- Marginson, S. (2002). The Phenomenal Rise of International Degrees Down Under. *Change* 34(3), 34-43.
- Matthews, B. P., Ueno, A., Periera, Z. L., Silva, G., Kekal, T. & Repka, M. (2001). Quality Training: Findings from a European Survey. *The TQM Magazine* 13(1), 61-68.
- RMIT (2002). *Enhancing Quality*. <http://www.rmit.edu.au/>. RMIT.
- Starr, L. M. (2001). Are Humans Obsolete as OSHA Instructors? *Occupational Health and Safety* 70(11), 58-64.
- Tatnall, A. & Davey, B. (1997). A View of EQA in Business Computing at RMIT. Victoria University, Department of Business Computing.
- Vidovich, L., Fourie, M., van der Westhuizen, L., Alt, H. & Holtzhausen, S. (2000). Quality Teaching and Learning in Australian and South African Universities: Comparing Policies and Practices. *Compare* 30(2), 193-209.
- Wilkinson, A., Redman, T. & Snape, E. (1993). *Quality Management and the Manager*. Corby, Institute of Management.
- Williams, P. (2002). Continuous Improvement. The Quality Assurance Agency for Higher Education. Available [http://www.qaa.uk/public/hq/hq10/hq10\\_contents.htm](http://www.qaa.uk/public/hq/hq10/hq10_contents.htm).

## BIOGRAPHY

Bill Davey has research interests in methodologies for systems analysis and systems development, Visual Basic programming, information systems curriculum, and information technology in educational management. Arthur Tatnall's research interests include technological innovation, information systems curriculum, Visual Basic programming, project management, electronic commerce, and information technology in educational management. Arthur and Bill have worked together on many projects.

# **SOCIAL LEARNING WITHIN ELECTRONIC ENVIRONMENTS**

## *Current perspectives and future directions*

Carolyn Dowling

*Australian Catholic University, 115 Victoria Parade, Fitzroy, Victoria 3165, Australia  
[c.dowling@patrick.acu.edu.au](mailto:c.dowling@patrick.acu.edu.au)*

**Abstract:** Within both educational institutions and the workplace, there are strong imperatives for learning to take place within an identifiably 'social' context, characterised by interactivity between learners and teachers, and between learners and their peers. Not only is this accepted as good pedagogical practice, but it is also important in situating learning within the type of co-operative, collaborative problem-solving environment characteristic of most contemporary workplaces. At the same time, online learning is becoming an increasingly important educational option for students at all stages of life. This paper explores some of the issues relating to how appropriate social modes of learning can be achieved within electronic environments, including consideration of the current and future roles of socially interactive software agents.

**Key words:** social learning, software agents, computer-mediated communication

## **1. INTRODUCTION**

Within both formal educational institutions and the workplace, the idea, stemming most obviously from the work of Vygotsky (1978), that knowledge is 'socially constructed' through a process of negotiation between learners and the world around them, has achieved wide acceptance in recent years. The notion that learning should be characterised by interaction not just between learners and their teachers but also between learners and their peers, is now regarded by most educators as good pedagogical practice. It is also seen as reflecting the way in which

knowledge is typically acquired and used in the team-oriented environment of the contemporary workplace.

At the same time, learning online is becoming an increasingly important option for full time, part time and even 'occasional' students. Well-recognised advantages include the ability to study at 'any place' and at 'any time'. This flexibility is of benefit not just to full time workers, but also to those students who are obliged to mix work with study in order to survive financially, or who may have difficulty in physically attending a particular educational institution. A further aspect of online learning that contributes to its attractiveness, particularly to younger people, is its synergy with the way in which they utilise Information and Communication Technologies to conduct much of their work and their leisure activities. But how effective are online educational environments in providing the social interactivity that we currently believe characterises the best pedagogical practices, and how can we ensure that we maximise this aspect of electronic learning?

## **2. CURRENT MODES OF ENCOURAGING SOCIAL INTERACTIVITY ONLINE**

Today a great deal of online learning is conducted through the medium of software 'shells' which enable teachers or instructors with little expertise to insert their course materials into predetermined structures. Most of these products include provision for course schedules, course materials, links to appropriate websites, testing of students' skills and knowledge, different types of record keeping and, very importantly, a range of options for facilitating communication. The types of communication facilitated would normally encompass teacher-to-student-group, teacher-to-individual-student, student-to-teacher and student-to-student, in both synchronous and asynchronous modes. It is customary to also distinguish between 'public' modes of interaction such as bulletin boards and contributions to email lists or 'open' chat environments, and 'private' one-on-one exchanges such as individually addressed email messages that clearly fulfil a different purpose.

How do these opportunities for person-to-person interaction compare with those available in the face-to-face classroom? Traditional classroom organisation favours the teacher-to-student-group model, with some provision for communication between the teacher and an individual student although, when this takes place within the public space of the physical classroom, it generally suffers from a lack of privacy and confidentiality. Traditional classrooms also incorporate some potential for student-to-teacher communication, although again this could rarely be classed as 'private' or individual communication in the usual sense. While student-to-student

communication is facilitated in many face-to-face classrooms, often through organisational structures such as 'group work', there are generally severe limitations imposed on the time and place at which this type of interaction is permitted. Opportunities for unmandated discussion between students do occur, but often the necessarily furtive nature of such communication diminishes its potential contribution to learning.

By contrast, the variety of modes of communication available within most online learning environments provides the flexibility for a range of different types of interaction. In a recent evaluation of courses offered in a combination of face-to-face and online modes, it was noted by this author that students and teachers like reported that they appreciated the ease with which communication could be facilitated both privately between individuals and between members of different sub-groups of the class identified for particular purposes (Student course evaluations, 2002).

Computer mediated social interactions have other potential advantages in relation to learning. In the absence of social 'markers' such as physical appearance, dress and so on, students may feel more able to engage in interaction than would otherwise be the case. Particularly where the course takes place entirely online, this may be enhanced by the degree to which they are able to exercise positive control over the persona they present to the rest of the group.

In summary, it would appear that the electronic medium has some advantages in facilitating the types of social interaction that are believed to mediate effective learning. For both student and teacher there are enhanced opportunities for individualised, highly specific interactions, in addition to an increased freedom to communicate at times of their own choosing, and perhaps at greater length and in more detail than is possible in a physical setting.

It is important to acknowledge, however, that currently this type of communication is overwhelmingly textual in nature, and lacks the richness of face-to-face interaction where words are reinforced by aspects of physical presence such as gesture, tone of voice, facial expression, 'body language' and so on. In the face-to-face classroom students are 'known' both to one another and to teachers in a very different sense. It is well recognised that electronically mediated communication is not 'the same' as face-to-face (Dowling, 2000), and this should be taken into account when considering the advantages and disadvantages of online learning.

### 3. FUTURE DIRECTIONS

Given that, in addition to their other advantages, online learning environments do have special potential for facilitating certain types of pedagogically helpful social interactions, how might we expect this aspect of their design to develop in the future?

More extreme facilitation of 'any place, any time' learning might well occur not through the traditional computer interface, but through the medium of portable handheld devices. Many of these already have the ability to combine auditory and visual data, including video representations of the speaker, with textual information. Furthermore they operate in a wireless environment, unencumbered by the need to be 'plugged in' (Multisilta, 2003). While traditionalists might balk at the idea of delivering instruction by means of a device that permits such a small amount of information to be visible at a time, it should be acknowledged that many young people now conduct much of the important 'business' of their lives through the medium of text messaging. As reported recently, 'More than 40 per cent of people aged 15 or older in Europe's three biggest economies use short messaging service (SMS) on cellular handsets, while 30 per cent use computer email, says research company GartnerG2' (McLuskey, 2002). The recent expansion of Instant Messaging (IM) introduces a further element with the potential to change the way in which we interact for work, leisure and also study.

In relation to the limitations posed by the screen dimensions of hand-held technologies, it should be remembered that in the 1980s the introduction of hypertext, now familiar to us as one of the structural foundations of the World Wide Web, caused considerable concern to theorists and researchers because of the need to 'chunk' information into segments significantly smaller than those to which we were accustomed in the context of paper-based print media. In this as in so many other aspects of our lives, we have proved to be extremely adaptable. Perhaps of greater concern are the broader social consequences of constant availability undermining the ability of individuals to structure the different aspects of their lives according to their personal preferences. While there is certainly enhanced potential for integrating learning activities within an environment appropriate to an individual learner, such as a workplace, there is also the possibility of educational activities spilling over into what is normally regarded as leisure time to a degree which would be unacceptable to many people.

Another area rich in potential for encouraging interactivity within online learning environments is the use of software agents, computer programs possessing varying degrees of 'intelligence', autonomy and personification, as participants in the social interactions that mediate learning (Dowling, 2002). The roles that can be undertaken by these electronic constructs are

rich and varied. Many of them, such as information retrieval and record keeping, incorporate a minimal 'social' component at best. Others, however, are specifically designed so as to enhance both the quantity and the quality of the interactions taking place within the online environment. Johnson (1998) provides the following overview of the possible roles of such entities, closing with specific reference to their capacity to contribute to the 'social' aspects of knowledge construction.

"Pedagogical agents are autonomous agents that support human learning, by interacting with students in the context of interactive learning environments. They extend and improve upon previous work on intelligent tutoring systems in a number of ways. They adapt their behaviour to the dynamic state of the learning environment, taking advantage of learning opportunities as they arise. They can support collaborative learning as well as individualized learning, because multiple students and agents can interact in a shared environment. Given a suitably rich user interface, pedagogical agents are capable of a wide spectrum of instructionally effective interactions with students, including multimodal dialog. Animated pedagogical agents can promote student motivation and engagement, and engender affective as well as cognitive responses" (Johnson, 1998).

The most obvious classroom roles that incorporate a social dimension are those of the teacher or tutor, and the fellow learner. Within the latter category we can include what is sometimes referred to as the 'tutee' – someone to whom the learner 'teaches' material that he or she has learned. This is an important aspect of the mutuality that characterises social learning.

While the idea of a computer program 'teaching' a student may appear to represent a return to the bad old days of overly simplistic instructional software, Johnson is correct in indicating that today's software agents are far more complex and flexible in their capabilities and modes of operation. For example:

"The user mental model of the system should be based on the metaphor of the 'invited professor' rather than the 'knowing everything own tutor'. ... Our first findings confirm the observation that today's users, accustomed to hypertext-like interaction, are more likely to accept this collaborative teaching metaphor, according to which their tutoring system is viewed as an intelligent hypertext browser, offering links to other tutoring systems with the right content and at the right time" (Solomos & Avouris, 1999).

The contemporary image of the teacher as a facilitator of learning rather than as the 'sage on the stage' is further reflected in descriptions of agent roles such as: "Each student working on the project will have an agent, operating in the background, watching progress, measuring it against the

plan, and taking remedial action when necessary” (Whatle, Staniford, Beer, & Scown,, 1999),

The notion of agents as fellow learners is most readily exemplified by the work of Chan and his colleagues over a number of years (Chan, 1996; 1998). As is the case with human classmates, their ‘learning companions’, anthropomorphised for young students in the form of friendly animals, possess differing competencies and degrees of knowledge of the content or skills domain being studied. A further example is described by Ju (1998) who writes of a computer based peer tutoring system employing two categories of agent – an ‘expert’, and a ‘learner’:

“... students become active learners who are guided to learn by teaching a computer. After the students watch how the computer expert solves a set of linear equations [the program] helps the human student act as a teacher in order to learn more about the subject matter. At this time, the computer plays the role of a student ...” (Ju, 1998).

While many educators would be uncomfortable with the notion that interaction with an electronic entity should entirely replace human-to-human communication in the classroom, it is easier to be supportive of pedagogical agents if they are seen as fulfilling a complementary rather than a substituting role within the online community of learners. Appropriate actions might include providing immediate and highly specific feedback to students at times when a human respondent is not readily available. The ‘any time’ aspect of electronic learning can and often does place extraordinary demands on human teachers in terms of their availability to provide support to their students at pedagogically appropriate moments.

Of course as with all aspects of electronic learning environments, there is always some potential for features, including socially interactive software agents, to be developed ‘because we are able to’, rather than because they will necessarily contribute positively to student learning. Happily this is generally well recognised by developers, as exemplified in the following comment made about one online learning environment based on constructivist principles, emphasising communication and collaboration, and also featuring elements of advanced technology:

“The author does not recommend that all CMC systems should have virtual-reality quality or avatars built-in. These tools can be made available and customized by users. The freedom of choices empowers the users to take control of their learning process. In some instances, the add-on tools can be a distraction for online conversation. In some instances they are great tools for increasing interpersonal connections. The use of the tools should match the pedagogical goals of an instructional unit, not just used for the sake of using the tools” (Chou, 2001).

## 4. CONCLUSION

The conjunction of two important imperatives in contemporary education and training is creating both opportunities and dilemmas for teachers and their students. On the one hand, new developments in mobile communication technologies suggest exciting and challenging possibilities for further enhancing the provision of opportunities for learning at a time and place of the learner's (or their employer's) own choosing. At the same time, there is increased recognition of the importance of learning taking place within a social context that reflects and models the type of cooperative, collaborative problem-solving environment characteristic of the modern workplace. Central to the productive resolution of what might appear at first to be somewhat contradictory trends in education is the capacity for electronically mediated learning environments to provide opportunities for social interaction in the service of knowledge construction. New and developing technologies provide a very flexible range of possibilities for communication between teachers and learners, between learners and their peers, and between human learners and pedagogical software agents. Interestingly, there are certain features of the newer mobile technologies that might have the potential to enhance the apparent 'social' abilities of interactive agents. In addition to augmenting the 'presence' of human communicators, the video and multimedia capabilities of handheld devices could be utilised to add depth to the animation or personification of agent software. A further area for investigation is the degree to which the abbreviated forms of text best suited to the small screen might assist in blurring the distinction between human and non-human participants in the social interactions mediating learning. In summary, it can be argued that significant synergies may exist between the new directions in communications technologies and the capacity of agent software to enhance the level of timely and informative communication within electronically mediated learning environments.

## REFERENCES

- Chan, T. W. (1996). Learning companion systems, social learning systems, and the global social learning club, *Journal of Artificial Intelligence in Education*, 7(2).
- Chan, T. W. (1998). *The past, present, and future of educational agents*. Retrieved 03/02/2000 from [http://www.apc.src.ncu.edu.tw/apc/ppt\\_chan.html](http://www.apc.src.ncu.edu.tw/apc/ppt_chan.html).
- Chou, C. (2001). Formative Evaluation of Synchronous CMC Systems for Learner-Centred Online Course. *Journal of Interactive Learning Research*, 12(2/3), 173–192.



- Dowling, C. (2000). Social Interactions and the Construction of Knowledge within Computer Mediated Learning Environments. In T. Downes. & D. Watson (Eds.), *Learning in a Networked Society*. (pp. 165–174). Kluwer, Boston.
- Dowling, C. (2002). The Socially Interactive Pedagogical Agent within Online Learning Communities, *Proceedings of the International Conference on Computers in Education ICCE 2002*, (pp. 30–34). Auckland, New Zealand.
- Johnson, W.L., (1998). Pedagogical Agents. *Proceedings of, the Sixth International Conference on Computers in Education (ICCE '98)*, (pp.13–22). Beijing, China, October 14–17.
- Ju, Y. (1998), Development and formative evaluation of a computer-based peer tutoring system. Proceedings of, the Sixth International Conference on Computers in Education (ICCE '98), (pp. 559–566). Beijing, China, October 14–17.
- McLuskey, D. (2002), SMS eats into email in Europe, *The Australian* (IT section), 12.11.2002, p.6.
- Multisilta, J. (2003), The Teacher in the Mobile World, *ICT and the Teacher of the Future*, (pp.257-266). Kluwer, Boston.
- Solomos, K., & Avouris, N. (1999). Learning from Multiple Collaborating Intelligent Tutors: An Agent-Based Approach. *Journal of Interactive Learning Research*, 10(3/4) 243-263.
- Dowling, C. (2002). Student course evaluations, June 2002.
- Vygotsky, L. (1978), *Mind in Society*, Cambridge, MA: Harvard University Press.
- Whatley, J., Staniford, G, Beer, M. & Scown, P. (1999), Intelligent Agents to Support Students Working in Groups Online. *Journal of Interactive Learning Research*.10, (3/4), 235–243.

## BIOGRAPHY

Carolyn Dowling is currently Head of the School of Business and Informatics at Australian Catholic University. During the last twenty years she has taught and researched a number of different aspects of ICT at University level. Her current research is focussed on electronically mediated communication and agent technologies.

# MOBILE TECHNOLOGIES AND EDUCATION

## *A Case Study at the Pori Art Museum*

Heikki Haaparanta and Harri Ketamo

*Tampere University of Technology, Pori, Finland*

**Abstract:** The objective of this study was to explore new and mobile collaboration technologies and to try to find more effective ways for museum visits with mobile technologies. The study was implemented in December 2002 with 20 Finnish high school students. The students were participating in alternative art course. All of the students seemed to learn quite easily the technologies and methods used in this study but still there was a lack of time in every lesson. This leads us to few important conclusions: When the new technology is used with new students and in new environments, it is necessary the reserve enough time for students to get familiar with new technology and new teaching arrangements.

**Key words:** Mobile learning, Mobile platforms, Collaborative learning, Multimedia, Non-formal learning

## 1. INTRODUCTION

This paper describes one experiment with the use of mobile devices in education conducted by the Tampere University of Technology. It describes the technologies, methods and arrangements that were used in the experiment. The paper offers an example of how mobile devices can be used in the future in education. The paper also gives a short overview about similar and ongoing cultural technology research in Europe.

The European Union's Fifth Framework Program has funded several projects that combine culture and technology. Perhaps the one most closely aligned to our research is the COINE project (COINE, 2002). The objective of the COINE project is to develop interactive service for museums and other cultural producers and repositories. Its main aim is to create a service whereby a user may create a narrative story while visiting the museum.

The COINE project differs from the study described in this paper particularly in terms of the use of mobile technologies and from the collaborative aspects that the Pori study has.

There have been several projects in the European Union which have explored the potential of web-based cultural content production and delivery — for example CHIMER (2001), CIPHER (2003) and PULMAN (2003). The main point of these projects lies in the quality of virtually produced content. As with this study, these projects have not focused on personal and social experiences what is able to get from culture.

- The objective of the CHIMER project is to improve the accessibility of cultural services, especially for children. Its goal is to combine and integrate different technologies (Internet, GPS, GPRS, WI-FI, GIS) so that any multimedia content developments can be delivered by means of the 3G network.
- The objective of the CIPHER project is to find different and innovative methods for the dissemination of cultural information at regional, national and global levels. The project is based in four culture forums that are producing and developing web-based information about their activities.
- The main purpose of the PULMAN project is to establish a network of museums and libraries that implement and provide the best practices of digital information presentation and production processes.
- The ACTIVATE project (2001) aims to find different models that can improve the quality of the processes by which local history and culture are documented. Its main target is to develop technological documentation that would help to improve the profile of rural areas in cultural tourism.

## **2. OBJECTIVES AND METHOD**

The objective of this study was to explore new and mobile collaboration technologies, and to try to find more effective ways to use mobile technologies for museum visits. The study was implemented in December 2002 with 20 Finnish high school students who were participating in an alternative art course.

The students worked for a total of eight hours. The first two-hour lesson was held in their own school. The main target of this lesson was to paint a self-portrait and to convert it into a digital format. The students first painted their portraits and then photographed them with a digital camera.

In a second lesson, the students worked with computers for two hours in the xTask learning environment. In this time, the students became familiar

with its use and possibilities. The purpose of the lesson was for the students to gain familiarity with the xTask virtual learning environment, which was developed for the course. Then they used the computer to write a personal work plan for the course. The work plans were saved in each student's personal folder in the xTask environment.

The third lesson consisted of two hours at the Pori art museum during which time they would explore the use of mobile technologies. The students were provided with mobile devices that they were meant to use during their museum visit. Four of the mobile devices were Compaq iPaq PDA devices. These PDA's allowed the students to make both audio and text notes about the pieces on display in the art museum. Two of the mobile devices were built especially to record video and sound notes. These two devices were built from a Fujitsu Lifebook laptop linked to a microphone and a web-cam. With all of these devices the students were able to make a number of different notes in different media formats, and were able to send them directly to their personal folder in the xTask environment.

In a fourth lesson they spent a further two hours using computers to organize the notes they had taken in the museum and save them in xTask so that other students were able to see them and comment on them.

Traditionally, web-based collaboration uses text-based tools. However, text isn't always the best way, or the optimal form, to make notes. Sometimes a quick thought or an idea needs to be documented immediately. Still, there are situations where traditional text is a more suitable way to make notes. Mobile devices and new mobile technologies offer new possibilities for creating different kinds of notes. The Pori experiment tried to combine the use of speech and video notes with traditional text notes.

Because working in teams is more difficult when you are working with a computer, the notes should be able to be recorded in situ — in places where people are actually collaborating. In this case it meant that the notes should be recorded in museum as the students were observing the art works. That is why mobility and mobile devices are necessary to perform this kind of study.

### **3. TECHNOLOGIES, TOOLS AND RESULTS**

The xTask learning environment that was used in this study is platform adaptive software. This means that the user is able to work with normal computers, PDA devices and hybrid platforms such as the Nokia Communicator. It also supports the use of sound, picture and video formats so that the user is able to use various media types and formats to provide notes and comments. The most relevant benefit from the use of xTask in this

study was that the same personal working environment was available both in museum and while working with the computers. The xTask server was located in the Tampere University of Technology, and could be accessed through Internet. In the Pori Art Museum there was a WLAN network, build over museum's existing network (Figure 1).

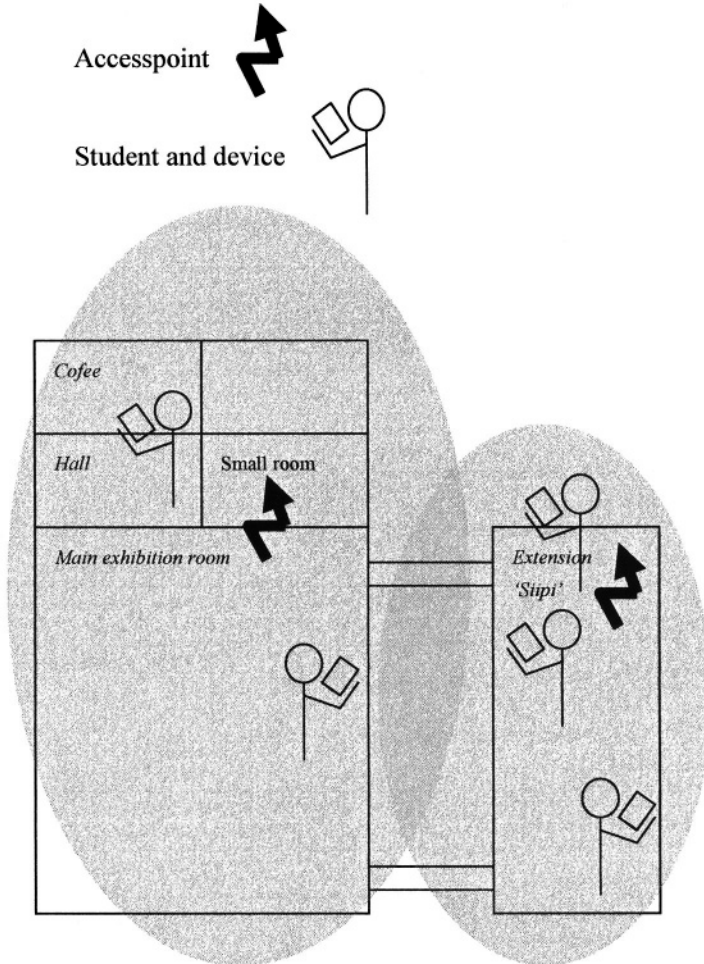

Figure 1. The WLAN in the Pori Art Museum

In the museum students were able to use two kinds of devices. One type of devices was Compaq iPaq PDAs (figure2). With them students could construct audio and text based notes and send them to xTask server.



*Figure 2.* Compaq iPaq PDA device. Constructing an audio note.

Other type of device was video-platform (figure 3). Video platform was build over small laptop computer (Fujitsu Lifebook B-serie) extended with web-cam and microphone. Naturally audio and text based notes could be created with this platform as well.



*Figure 3.* Constructing a video note with a Fujitsu laptop and a web cam.

Students could use both types of devices, but only one at the time. The audio notes were the most popular way to construct notes. That was not a surprise, but the lack of good video notes was. It seems that constructing a video note requires more skill and time than an audio note. Text-based notes were not used when it was possible to make audio or video notes.

#### **4. CONCLUSIONS**

Generally the students were enthusiastic and seemed highly motivated about their work. This was particularly evident when the students were working with the mobile devices in the Pori art museum. There were probably several factors that increased the students' motivation.

- First, this was an alternative course that students had selected for themselves, so they were presumably already interested in work with art.
- Secondly, three of four lessons were held outside of the normal classroom; a previous study has shown that all actions that happen outside of the normal working environment increase students' motivation.
- Also, the work with new technologies, and especially with mobile devices, increases their working motivation.

- Students who took part in this study did not have any previous experience with the use of similar technologies, and so their motivation is presumed to be higher.

All of the students seemed to have little difficulty in learning the technologies and methods used in this study. Still, there was a lack of time in every lesson. This leads us to few important conclusions:

- When new technology is used with new students and in new environments, it is necessary to reserve enough time for the students to become familiar with the new technology and new teaching arrangement.
- While students are collaborating, they don't do the task all of the time.
- The major part of the time goes when students explore and play with new devices and environments.
- It is always possible that techniques do not work in a way that was planned.

While there have been similar, previous studies, that combine technology and culture, this study is different in its use of mobile technology in a virtual collaborative environment. The main focus for future research and development should be on supporting the use of mobile devices and collaborative group learning. This might lead us to developing non-formal learning that is place or time independent.

It is also potentially useful to explore the combination of still picture (photographic) notes and voice notes. A possible technology platform for this is Multimedia Messaging (MMS), which provides an excellent technical platform for the transfer of voice notes and still picture notes.

## 5. REFERENCES

- Activate. (2001). *ACTIVATE Project homepage*. Available <http://www.activate.ie/>
- Brophy, P. (2002). *COINE - Cultural Objects in Networked Environments*. Available <http://www.cultivate-int.org/issue7/coine/>
- CIPHER. (2003). *CIPHER – Communities of Interest Promoting Heritage of European Region project homepage*. Available <http://www.cipherweb.org>
- Chimer. (2001) *CHIMER Project homepage*. Available <http://www.chimer.org/>
- COINE. (2002). *COINE Project homepage*. Available <http://www.uoc.edu/in3/coine/>
- Davis, R. (2002). *PULMAN: rolling on by night and day*. Available <http://www.cultivate-int.org/issue7/pulman/>
- Kelly, A. & Clery, C. (2002). *Activate: New Access And Services For Cultural Content*. Available <http://www.cultivate-int.org/issue6/activate/>
- Ketamo, H. (2002). *User and Platform Adaptation in Web-based Learning Environments*. Doctoral thesis, Tampere University of Technology, Tampere, Finland.
- Mulholland, P., Zdrahal, Z. & Collins, T. (2002) *CIPHER: Enabling Communities of Interest to Promote Heritage of European Regions*. <http://www.cultivate-int.org/issue8/cipher/>



- PULMAN. (2003). *PULMAN – Public Libraries Mobilising Advanced Networks project homepage*. Available <http://www.pulmanweb.org/>
- Weiss, D. (2002). *CHIMER: Children's Heritage Interactive Models for Evolving Repositories*. Available <http://www.cultivate-int.org/issue8/chimer/>

## **BIOGRAPHY**

Heikki Haaparanta has research interests in the use of technology in education. Recent research has focused on use of technology in the curriculum and the possibilities of digital and mobile portfolios.

Harri Ketamo has research interests in educational technologies and user modelling. Recent research has focused on adaptive studying environments and developing network based observation methods and tools.

# **TOWARDS MULTILATERAL CO-OPERATION OF UNIVERSITY, ICT-BUSINESSES AND PUBLIC ORGANIZATIONS IN THE ROVANIEMI REGION**

*Developing Network Competence*

Mika Saloheimo, Miina Konttinen, Ilkka Kamaja and Juha Lindfors

*University of Lapland, Department of Research Methodology*

**Abstract:** The Network Competence (NetCom) project consists of a master's degree programme as well as education and development services for its corporate partners. The goals of the project are to develop regional ICT industries in co-operation with University of Lapland and other public organizations. ICT education and research should be based on the long-term needs of the industry. The project is currently surveying the needs of its corporate partners, and the implications of the findings for training and development are being considered in the project's feedback and evaluation processes.

**Key words:** industry training, organizations, partnerships, educational management

## **1. INTRODUCTION**

The Rovaniemi region consists of the City of Rovaniemi and its surrounding municipalities. The city is the capital of Finland's northernmost province, Lapland and is an international centre of business, administration and education. The leading industries in the region are tourism, information and communications technology (ICT), cold and winter technology, special foods and wood products.

The University of Lapland was founded in 1979. While it is a comparatively small institution, with an enrolment of 3500 students, it is an important regional actor. The University has four faculties — Law, Education, Social Sciences and Art and Design. Information Technology

(IT) has been taught in the Department of Research Methodology since 1997. The subject cannot be studied as a major at the University and the master's programmes described below have been established as a solution to this shortcoming. The first master's programme (ITMO) was started in 2000 and the second (NetCom) in 2002. The basic idea of the programmes is that students complete a major (82.5cr) in one of the faculties and take studies (82.5cr) equivalent to a major in IT. The resulting programme, in particular the master's thesis, is cross-disciplinary, focusing on IT applications in the subjects taught in the faculties. Figure 1 illustrates the cross-disciplinary studies in IT.

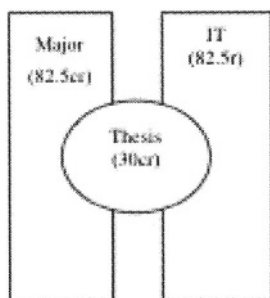

*Figure 1.* Degree structure of the IT master's programmes.

In the following sections, we describe the goals, background research, organization and future vision of the Network Competence project.

## **2. GOALS OF THE NETWORK COMPETENCE PROJECT**

The ICT sector is considered strategically important in the Rovaniemi region, and there is growing need for people with know-how in the field (ICT sector strategy for the Rovaniemi region, 2-3). One aim of the NetCom project is to further the development of the ICT industry and the businesses that are heavily reliant on information technology. The goal of the education, research and collaborative projects supported by the project is to provide opportunities for organizations, businesses and individuals to develop and broaden their IT know-how significantly.

An assessment of university master's programmes by the Ministry of Education has indicated that although many of the master's programmes at the University of Lapland emphasise entrepreneurship, their links to business

life rely largely on the personal contacts of the individuals involved (Raivola et al., 2002, p77). One of the express objectives of the University's adult education strategy is the promotion of interaction between the University and working life. (see University of Lapland 2010 Strategy). Here, NetCom has set itself the goal of long-term, broad-based cooperation between the University and the business sector in Lapland. This will take the form of cooperation between the IT programme at the Department of Research Methodology and ICT sector businesses in the Rovaniemi region.

One of NetCom's principal goals is to apply a client-centred model to the planning, implementation and evaluation of the education it offers. Such an approach would enable research and education to better address the needs of the public sector and business life. Client-centeredness in the planning and implementation of IT training means working to take into account the expectations and needs of the target group and/or the demands of working life with regard to IT skills.

### **3. SURVEY OF CORPORATE PARTNERS**

In August 2002, the Department of Research Methodology began conducting a survey to obtain background information that would facilitate implementation of the NetCom project. The results of the survey will be used in planning the master's programme and client-centred staff training that is tailored to client needs; the findings will also stimulate ideas for development projects and other projects. The survey encompasses the needs of businesses with regard to know-how, training and cooperation. The focal interests are: a profile of staff know-how in the target businesses, the training available to the staff, and the needs for development in these areas; the need for projects, research and development efforts; and the role of the university in serving businesses and the region.

The businesses surveyed comprise the ICT sector businesses in the Rovaniemi region as well as businesses that make extensive use of ICT. A number of public-sector organizations have also been included. For the most part, the persons taking part in the survey are members of staff who are responsible for staff training and development. Requests for participation in the survey have been sent to 17 organizations or businesses, of which 12 have taken part to date, most of these ICT businesses. The 12 include the principal ICT businesses in the region.

The survey data have been collected using interviews and pre-interview tasks. Interviews are semi-structured and are conducted as individual or pair interviews. In the tasks, the businesses are asked to plan a programme of training that suits their needs based on the courses currently offered in the

Department of Research Methodology. They also have the option of including courses from fields other than IT.

The survey is in progress and the target group is growing. Preliminary findings are available and these are presented in what follows:

*Expertise needs.* ICT businesses are increasingly required to have theoretical expertise as well as practical skills. The demands made of staff have expanded and deepened, and a strictly technological orientation to one's work is not longer sufficient. The know-how presently required lies in the areas of planning, development, project management, problem solving and general management. Businesses need a diverse range of experts who have the ability to adapt to changes, an understanding of the social dimension of their work, and a desire to develop themselves.

*Educational needs.* The businesses need both university-level, degree-oriented courses and short-term expert training. The courses offered at the University should be multidisciplinary in nature, i.e., ones in which it is possible to combine ICT and other professional fields. The businesses involved would like some input into the ICT training provided, in particular the curricula. Other priorities noted include the quality of training and research and the fit between training and working life.

*Project, research and development needs.* All of the business surveyed displayed an interest in project, research and development work that would be carried out in collaboration with the University. This work has to be sufficiently broad in scope and should serve the interests of not only the businesses involved but also the Department of Research Methodology. Many of the business have experiences of such cooperation with various educational organizations.

*Role of the University in serving businesses and the region.* The University of Lapland should increase cooperation with businesses and organisations in the surrounding community. In order to function smoothly and develop, the ICT sector needs an infrastructure that includes both high-level research and a qualified workforce. With a view to ensuring that these aims are met, the businesses suggested that the education in IT offered at the University of Lapland should be developed into a degree programme. Among other things, this would make it possible to implement the bachelor's-to-master's bridge programme that they consider necessary. The businesses regard NetCom as a sound foundation for developing cooperation between the Department of Research Methodology and the business community as well as for furthering teaching and research in IT.

Further discussions with the corporate partners (see following section) have provided a more detailed view of the training needs. There is a need for training in the field of information technology, e.g., in software architectures, methods of software production, mobile applications and

information security. Furthermore, there are needs in fields other than information technology, e.g., management, business know-how and the use of IT in different organizations and businesses.

#### **4. ORGANIZATION OF THE NETWORK COMPETENCE PROJECT**

The Network Competence project is financed both publicly and privately. Public funding comes from the European Social Fund and the municipalities of the Rovaniemi region. Private funding comes from NetCom's corporate partners.

The organizations involved in NetCom are the State Provincial Office of Lapland and Business Developer *eero* Rovaniemi. The project's corporate partners are: CCC Systems Ltd., GeraCap Ltd., LapIT Ltd., Saraware Ltd. and Sonera Plc. Two of the corporate partners are SMEs. The organization of NetCom is presented in Figure 2.

GeraCap designs software and communication technologies. Saraware designs real-time communication systems. CCC Systems supplies customised information systems. LapIT produces network services, support and training. Sonera is a tele-operator. The operations of the project's corporate partners can be roughly divided into two categories: software production and network services/technologies.

Business developer *eero Rovaniemi* facilitates and develops information-intensive business activities as well as coordinates different projects and the marketing of the region. Closely linked to *eero* is the Aurora Borealis Technology Center (AB), whose goals include the creation of a testing platform for wireless services in the field of travel and tourism (navigation, experiences, etc.) Applications for distance health care and leisure are also under consideration as part of the Center's Testing Lab (TL).

The University of Lapland and its Department of Research Methodology are the executive and coordinating organization for NetCom. The role of the project's corporate partners and *eero* is that of advisor and funding organization. The State Provincial Office is the legal supervisor of the project and provides most of the funding.

There are two main policy-making units in NetCom. The *Steering Group* comprises representatives of the project's different stakeholders; such a body is a common tool for managing European Union (EU) projects. The Group handles administrative tasks and legal supervision, for example, drawing up the annual budget framework. Modifications to the project plan must be accepted by the Group. The Group's working procedures can be described as formal.

The project's other policy-making unit is the *Advisory Board*, which has a key role in the NetCom process. All the companies and organizations directly involved in NetCom have membership in the Board. Representation of other organizations (i.e., other units of University of Lapland) is possible where necessary.

The Advisory Board concentrates on questions of substance related to the development of regional ICT business activities. It evaluates different needs, ideas and, naturally, the operation of NetCom. The Board is an important part of the feedback mechanism. It works more informally than the Steering Group and adheres to the rules and restrictions set by the Group.

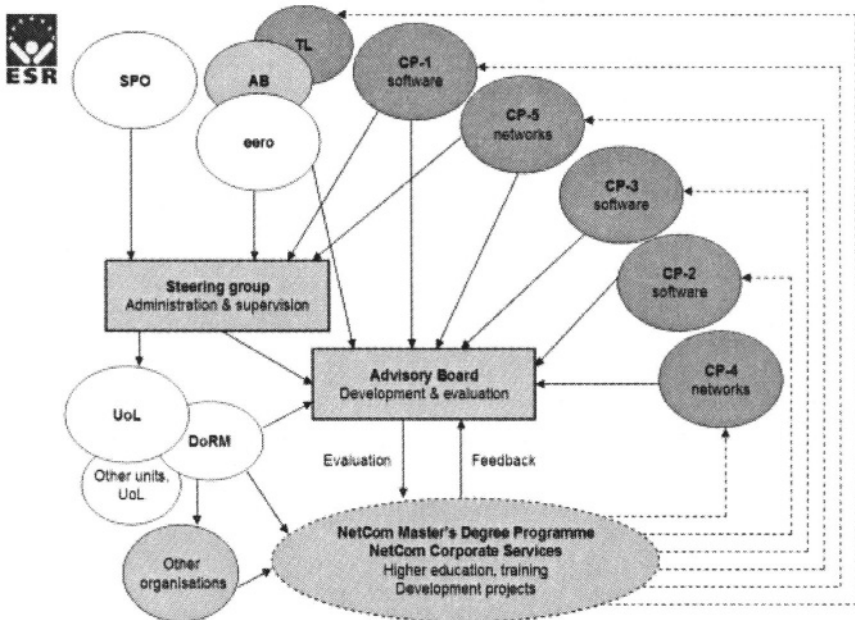

*Figure 2.* Organization of the Network Competence project. Legend: SPO = State Provincial Office, eero = Business Developer eero Rovaniemi, AB = Aurora Borealis Technology Center, TL = Testing Lab, CP-N = Corporate Partner N, UoL = University of Lapland, DoRM = Department of Research Methodology.

In exchange for their investment in NetCom, the corporate partners receive NetCom Corporate Services. Corporate partners are full members of the Advisory Board and influence the long-term (degree-level) education in Information Technology and short-term training of their employees. In this way, the education can be designed with the needs of working life in mind. The Board also participates in the quality management of IT education at the University of Lapland.

NetCom's master's degree programme provides highly educated potential recruits for its corporate partners. Students in the programme are encouraged to do their thesis and practice projects for the corporate partners. NetCom Corporate Services provides a certain amount of customised training based on the needs of the partners. Partners' employees can also participate in the courses that make up the degree programme. The Board also considers potential development projects. Development can be targeted to a partner's business processes and development projects can involve individual or multiple partners. An important source of these projects is the Aurora Borealis Technology Centre and Testing Lab.

## **5. CONCLUSIONS**

The Network Competence project is still in its early stages. The project will end in December 2005. The NetCom master's degree programme started in November 2002 with 17 students, and more students can apply in autumn 2003. There is a clear need for an established cross-disciplinary degree in Information Technology instead of separate degree programmes. This will be linked to the reform of higher educational system in year 2005. The expertise and educational needs of the project's corporate partners have been surveyed and there will be certain customised short-term training courses starting in autumn 2003.

NetCom's Advisory Board is to be a permanent body for liaising between companies and the University. In the future, there will be a need to expand the Board's membership to include representatives from companies in other industries (i.e., travel and tourism) in addition to ICT. NetCom has already created a functioning network of contacts between local companies and the University.

The Network Competence project has started off well, with the initial problems of defining and organising the NetCom Corporate Services now mainly solved. The services offered are mainly based on present functions of the University, presented and implemented in a client-centred manner. Corporate partners differ somewhat in their needs for services, but there are certain synergies between them.

Customised training for the corporate partners will be provided partly by third parties. The Department of Economic Sciences and Tourism offers many courses that are relevant for the partners (management, marketing and other business-related studies). Some IT-related training will be provided by outside organizations.

Corporate partners have provided valuable feedback for the information technology curriculum at the University of Lapland in which they have



identified salient concerns. One is how to implement the courses so that they will be easily accessible to the personnel of the corporate partners. Traditional implementation (lectures, exercises and examination) should be rethought.

There will probably be some administrative concerns related to the de minimis regulation, which pertains to public support and funding for companies. Also, the training provided by outside organizations has to be arranged through competitive bidding. On the educational side, there is a need for consulting the local SMEs (other than those in the ICT sector) on how to make use of ICT in their business. One future challenge is to develop research that will support the regional ICT industry (or any regional industry). The research possibilities will be surveyed in autumn 2003. Thus far, no individual corporate partner has indicated detailed needs where research is concerned; rather, it is probable that most of the research needs will emerge from Business Developer eero Rovaniemi and Aurora Borealis Technology Centre.

## REFERENCES

- Lapin yliopisto 2010-strategia [online]. (accessed 4.2.2003). Available at <http://www.urova.fi/home/suun/strategiat/index.htm>.
- Raivola, R., Himberg, T., Lappalainen, A., Mustonen, K. & Varmola, T. (2002). *Monta tietä maisteriksi. Yliopistojen maisteriohjelmien arviointi. Korkeakoulujen arviointineuvoston julkaisuja* 3:2002. Helsinki: Pikseri julkaisupalvelut. Available at: [http://www.kka.fi/pdf/julkaisut/KKA\\_302.pdf](http://www.kka.fi/pdf/julkaisut/KKA_302.pdf).
- Rovaniemen seudun ICT-alan strategia [online]. (accessed 4.2.2003) Available at: <http://www.rovaniemi.fi/files/ICT-alan%20strategia.pdf>

## BIOGRAPHY

Mika Saloheimo (mika.saloheimo@urova.fi) is the NetCom-project's Planning Officer. His research interests are in the use of ICT in business processes. Miina Konttinen (mina.konttinen@urova.fi) is the project's Educational Planning Officer and is writing her master's thesis on the competence needs of the ICT businesses in the Rovaniemi region. Ilkka Kamaja (ilkka.kamaja@urova.fi) is the development manager and is working on a doctoral dissertation dealing with a client-centred educational planning model. Juha Lindfors (juha.lindfors@urova.fi) is professor in ICT and his research interests are in learning environments. His thesis dealt with modern learning environments for Control Engineering.



## **SECTION 5: LEARNING ENVIRONMENTS**

# EXPERIMENTING WITH DIGITAL TELEVISION LEARNING ENVIRONMENTS

Päivi Aarreniemi-Jokipelto<sup>1</sup>, Juha Tuominen<sup>1</sup>, Seppo Kalli<sup>2</sup> and Tommi Riikonen<sup>3</sup>

<sup>1</sup>Industrial IT Laboratory, Helsinki University of Technology, <sup>2</sup>Digital Media Institute, Tampere University of Technology, <sup>3</sup>Ortikon Interactive Ltd.

**Abstract:** Digital media environment has been changed significantly during the last few years. The huge progress in communication technology and the launch of digital television have opened up new opportunities for distance learning. Interactive digital television is providing a new and flexible learning environment. The Industrial IT Laboratory of Helsinki University of Technology has made research in utilising digital TV as a learning environment for University courses and the students have had a chance to study using digital TV since September 2002.

**Keywords:** Interactive, digital television, learning models, Higher Education,

## 1. INTRODUCTION

The Industrial IT Laboratory in Helsinki University of Technology is responsible for the Motive- Modern Data Networks in Education -project. Motive is a content-production development project financed by the European Social Fund. The objective is to use Internet and digital TV to create interactive and flexible courses. The overall project emphasizes several research interests within the learning service deployment chain, from service editing and broadcasting finally to utilization at the student side together with involvement of different feedback mechanisms.

According to Garito (2001) digital TV can give concrete answers to life-long educational needs and it can be a useful tool for the creation of new knowledge and new skills.

The use of digital TV as a learning environment does not mean that the learner is seen in a passive role, just watching the television. In our case, the learner has a very active role in the learning process. She has a total control of the material and can pick the parts best suitable for her purposes. This type of study is very flexible for the student as she can utilise hyperlinks in order to move from one place to another in the study material, in the same way as on the Internet. Also, the exercises included in each section of study can be done by pressing buttons on the remote control.

Ortikon Interactive Ltd., which specialises in digital television technology and services, is responsible for supplying the technology that is required for the studying environment. The technology platform and the necessary products were already in existence. What is novel is their application to the field of electronic learning. The Motive -project combines Ortikon Interactive's technical expertise and the Industrial IT Laboratory's expertise in online pedagogy and content production.

In this paper, we report the first experiences both from student and content producer's point of view. The first course where digital TV was used was Local Demands for Global Enterprising. The feedback from the students was very positive and encouraging. They felt that digital television is very suitable for educational purposes and that they would like to study more utilising digital TV.

## **2. TECHNOLOGY**

The core of the learning environment is the **ORTIKON ACE<sup>®</sup>** Learning Suite, developed specially for the management of interactive digital TV services for learning purposes. It makes adding, maintaining and finally distributing of learning services simple without need for special IT skills. It is "the heart" of the system, which connects all the needed sub-systems (content databases, control computer, return channel, broadcast channel, etc.) to each other and handles the feeding of the content and applications to the broadcasting channel via object carousel servers. The system also receives the requests coming from the digital television receiver via return channel.

It is by means of the Learning Suite that the content producer creates and maintains its services and transmits them to the recipient. Also, two interactive digital TV applications are utilised: digital television portal displays the learning content on the TV screen where it can be browsed using a remote control, while digital TV real-time discussion forum is used for organising any discussions that may be necessary between tutor and students.

Remote control operated virtual keyboard on TV screen can be used for entering text. It is also possible to utilise other types of devices such as GSM phone's SMS or MMS messages for providing the content to the learning system.

There is a way to control the access to the digital television services. Students will use both a username and a password to enter and study in the course. Also the legal aspect is considered; all students participating this type of course have to sign a form in advance, stating that they allow their names to be seen in the conversations in digital TV.

### 3. PEDAGOGY

It is not enough to have only learning material in digital form. The whole learning process, including conversations and assignments, should be in digital environment as depicted in Figure 1.

Learning material	Learning process
<ul style="list-style-type: none"> <li>• lecture material</li> <li>• links</li> </ul>	<ul style="list-style-type: none"> <li>• conversations</li> <li>• assignments</li> <li>• guiding and tutoring</li> <li>• groupwork</li> <li>• creating and sharing new information</li> </ul>

Table1. Learning in Digital television.

Hiltz (1998) says that the premise from which all online teaching should begin is that the goal is to build a learning community for exchanging of ideas, information and a feeling of community. Using a return channel in digital TV makes that possible. Students would have a chance to discuss with other students, experts and tutors. They would be able to share knowledge and their competence with each other. In the interaction with each other, students would actually be able to create new knowledge. That is very important, especially in the areas where information is getting obsolete very fast. With the help of the tutor the learning process is always guided to the right direction. Also co-operation with other students, experts and tutor is playing an important role.

We are using problem-based learning (Hakkarainen et al., 2001) as a background theory in our courses during the coming autumn. It means that

students are solving a problem in a real life cases. The studying happens in small groups. For communication between the members of the group, digital TV is providing a real-time discussion forum.

#### **4. ASSESSMENT OF LEARNING**

According to Rowentree (2003), the method of assessment affects how and what students are studying. In Local Demands for Global Enterprising-course we are using multiple choice- questions and participating case discussions, as a criteria of assessment. With the multiple choice- questions it is possible to check how well the terminology and concepts are understood, as well as how the most important details are known covering the whole course.

The discussions show the ability of student's understanding of the subject as a whole. It also makes it possible to estimate how well students have figured out the problems in the subject and the cases used, as well as their ability to see the subject and problems analytically.

#### **5. CONTENT PRODUCTION**

We have had two ways to produce text material for digital TV portal. We have used both commercially available XML editors and also made our own MHP parser for producing pages. With parser the user does not have to know anything about HTML, selections from the database are picked easily with a mouse. A disadvantage is that the MHP-parser does not allow changing pages. If the user wishes to make some changes, she would have to do those with a XML editor.

Now we have a third way to produce pages with our own database for digital learning materials. This allows transferring the material for digital TV with just a few keystrokes. This database makes it easy to re-use the material made for another course. It is also possible to transfer the material for different devices, such as digital television, PC and mobile phones. In the database for digital learning material the LOM standard (IEEE LOM-Learning Object Metadata version 6.4) is partly included.

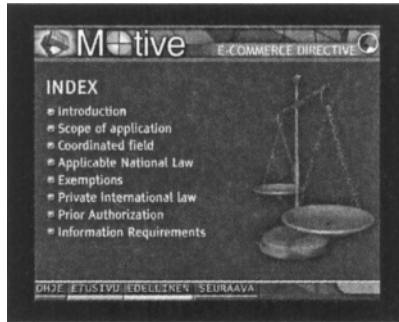

Figure 1. A sample screen from our course materials

Our new course in digital TV, Global Competencies and Interpersonal Skills in eBusiness, is produced with the help of this database. First the learning material is entered into the database and then easily, with a few keystrokes, transferred into a suitable form for digital TV.

## 6. RESULTS

Feedback from the students has been very positive and encouraging. They feel that digital television is very suitable for educational purposes and they would like to study more in digital television. They also said, that it is easy to use digital television as a learning environment. The multiple choice questions were especially liked, because the easy and fast feedback on wrong answers.



Figure 2. Users discussing the use of the learning environment.



All of the students were very familiar with the use of Internet and text television and that might be one of the reasons why they felt that digital TV is easy to use. It took them only few minutes to learn how to navigate and study in digital TV. The structure of the course was so simple, that there was no change to get lost.

Students were hoping in their feedback, which was gathered by an inquiry form, that coloured buttons could be used to get to a previous and next page in future. In the new version of the digital television portal software, which will be used in autumn 2003 course, there are new features available that give more freedom for navigation between pages.

Students felt that seeing the normal TV broadcasting in the corners of the TV-screen was disturbing their concentration. In the new version students have the chance to choose the way the learning content is laid out on the TV-screen. It will be possible to cover the total screen, but also to have the normal broadcast shown in smaller screen in selected area of the big screen.

## **7. FUTURE PROSPECTS**

During the autumn 2003 we are planning to test the use of the return channel in conversations and in delivering the assignments. Next course to be produced for digital television is "Global Competencies and Interpersonal Skills". Content production will be much easier than it was in the first course, because now tools for content production are available. It is possible to use commercially available XML editors and create suitable templates. In templates it is possible to have different kinds of layouts and it is easy to add headings, text, links and images to the templates. One important issue is also possibility to preview the content on PC before uploading to the database.

We will use both SMS and MMS-messages in Global Competencies and Interpersonal Skills-course. Digital television discussion forum application provides an environment to convey GSM based discussions in digital TV. It is possible to moderate and lead the conversation. Digital television e-mail application includes all key elements of an e-mail system and additional features, which help to send short messages including pictures from TV-to-TV or TV-to MMS enabled phones.

At the moment we are building a new conversation forum for digital TV. It will be possible to use SMS, PC and digital TV for sending the messages to be seen in digital TV discussion screens. We are trying to make the learning environment in digital TV as flexible as possible for our students. If they happened to be in a place where digital TV cannot be seen, it still would be possible for them to study, with the help of i.e. a PC.

## 8. CONCLUSIONS

Studies in digital TV combine the familiarity and ease-to-use of the existing medium and the extensive opportunities offered by the technological characteristics of the new medium. Digital TV enables a large variety of background information and additional data to be included.

The feedback from students indicates that digital TV is suitable to use as a learning environment. However, it does not mean that everything is perfect right now, but we can develop digital TV incrementally to become an interactive and personalized learning environment and will continue the research in the area.

The research includes new tools (i.e. identification) and methods for personalized learning, new communication tools and devices to improve interaction and use of return channel in delivering of assignments and conversations. The main issue in content production for learning is that the chosen technology is suitable for the content. Everything does not need to be the highest technology, but the technology should support the learning process and give some added value to the learning.

## 9. REFERENCES

- Garito, M. A. (2001). *Telematics: Digital Television and Life Long Learning*. Dublin: European Education Technology Forum
- Hakkarainen, K. L. & Lipponen, L. (2001). *Tutkiva oppiminen älykkään toiminnan rajat ja niiden ylittäminen*. pp.175-206.
- Hiltz, S. R.. (1998). Collaborative Learning in Asynchronous Learning Networks: Building Learning Communities. Keynote address to the WEB98 conference, Orlando, Florida, November. Retrieved 27.2.2003 from [http://eies.njit.edu/~hiltz/collaborative\\_learning\\_in\\_asynch.htm](http://eies.njit.edu/~hiltz/collaborative_learning_in_asynch.htm)
- IEEE. (2002). IEEE-Learning Object Metadata version 6.4 (2002, 08.05.2002). Available <http://jtc1sc36.org/doc/36N0255.pdf>
- Rowentree, D. *Designing an assessment system*, Retrieved 27.2.2003 from <http://iet.open.ac.uk/pp/D.G.F.Rowentree/assessment.html>

## 10. BIOGRAPHY

Päivi Aarreniemi-Jokipelto is responsible for the Motive-project, which has developed the use of digital television as a learning environment. Her research interests include e-Learning, especially interaction, learning process and personalized learning as well as the use of digital television as a learning environment from both technical and pedagogical sides.

Juha Tuominen is interested in the research and development of interactive digital environments including DTV, web, mobile and virtual simulation technologies. Recent

projects of his laboratory have developed pilots in the areas of e-Learning, DTV, personal navigation (GPS & GSM), mCommerce, logistics, and physical simulations. The diverse ICT activities of the laboratory have also yielded a large number of courses using various e-Learning techniques.

Seppo Kalli is a part-time Professor at the Signal Processing Laboratory at the Tampere University of Technology, Finland. He holds a Dr. Techn. (PhD) degree in Information Technology from the Tampere University of Technology. Dr. Kalli is also a Managing Director of Ortikon Interactive Ltd., a company specialising in digital television and mobile communication technologies ([www.ortikon.com](http://www.ortikon.com)). Seppo Kalli has a long history of working in the field of digital television. His research interests include digital audio-visual systems, multimedia technologies, digital signal processing and digital communication technologies.

Tommi Riikonen is a Vice President of Operations at Ortikon Interactive Ltd., a company specialised in digital television and mobile communication technologies ([www.ortikon.com](http://www.ortikon.com)). He holds a Master of Science degree in Computer Science from the Tampere University. Tommi Riikonen has a strong knowledge of digital television systems in satellite, cable and terrestrial environments. This knowledge spreads to the spectrum of DVB systems: production, broadcast, transmission equipment, receivers, returnpath, APIs' etc. His special research interests areas have been applications, user interfaces and usability in digital television environment.

# **PRINTED MEDIA, HYPERTEXT AND CHATTERBOTS IN LEARNING**

## *A Comparative Study*

Maria José Carvalho De Souza Domingues<sup>1</sup> and Raul Sidnei Wazlawick<sup>2</sup>

<sup>1</sup>*Regional University of Blumenau,* <sup>2</sup>*Federal University of Santa Catarina*

**Abstract:** This paper compares the influence of printed media, hypertext and chatterbots in the learning process of undergraduate business students. It has been found that chatterbots provide better results in terms of learning, especially in regard to the students' ability to answer discursive questions. The conclusion is that a chatterbot is more effective than hypertext and printed media for educational purposes.

**Keywords:** Chatterbots, Hypermedia, Learning systems.

## **1. INTRODUCTION**

While the use of Information and Communications Technology (ICT) in Education is largely supported by hypertext and its variants, such as the Internet, there has been little work done about the application of chatterbots to learning situations (Laven, 2000; Primo, 2000). Chatterbots are programs that are able to simulate conversation with a human partner. Chatterbots are widely used in entertainment web sites and for e-commerce. We believe that chatterbots can also be useful for educational purposes. The understanding of information presentation and recuperation process that underpin the operation of chatterbots in different types of media can help in the learning process. The main purpose of this work is to verify the effectiveness of chatterbots in the learning process of undergraduate business students.

According to Laven (2000) and Leaverton (2000), chatterbots are computer programs that use artificial intelligence to simulate dialogues with users. Faqbots are chatterbots designed to answer simple and frequent questions about their Frequently Asked Questions (FAQ) database (Laven,

2000). These kinds of chatterbots are found in many e-commerce sites. Examples of Faqbots are LuciMcBot and Roy (<http://www.artificial-life.com>), Nicole (<http://an1-sj.nativeminds.com/home.html>) and Linda (<http://www.extempo.com>).

When using chatterbots in learning, the idea is that the students would have complementary material to work with that they could use in conjunction with a chatterbot when the teacher is absent. Little research has been done in this area. Most of the previous works report using chatterbots as intelligent tutors that propose questions and direct the dialogue with the students (Graesser et. al., 1999).

## **2. HYPOTHESES**

When using chatterbots, students assume an active role in the learning process; a different role from those they often adopt when using hypertext and printed media. In this case they need to formulate questions and not only read information prepared by others. It helps them to assign meaning to the information and relate it to previous knowledge. It leads to our first hypothesis.

### **2.1.1 Hypothesis 1**

The use of chatterbots will improve the quality of learning compared to the use of hypertext and printed media. However, chatterbots present a limitation when compared to hypertext. In hypertext systems, the information is easily accessed by navigation. The chatterbot requires that the user formulate a question in order to give access to the stored information. If the right questions were not asked, the information remains hidden of the user. Therefore, we believe that students using chatterbots will recover less information than students using a hypertext. However, because of the way the information is accessed in the chatterbot, we also believe that the information retrieved will be better understood and retained by the student. It leads to our second hypothesis:

### **2.1.2 Hypothesis 2**

Although a chatterbot user retrieves less information than a hypertext user, the information retrieved is better interpreted and retained.

### **3. METHODOLOGY**

Some problems on using chatterbots in learning environments are discussed by Primo (2000):

- The technology has inherent limitations.
- The dialogues are predefined in a certain way.
- When the designer defines the questions (or keywords) and appropriate answers, he/she defines the scope of what can be asked to the chatterbot.
- Questions out of the scope would not have an answer associated, and should lead to an evasive answer, or to a suggestion to change the subject.
- Another difficulty that students may consume time trying to find answers that do not exist in the database.

The solution to cope with those situations is to produce chatterbots with very strict and delimited scope. This can significantly reduce the number of problems reported.

Another problem identified by Chen and Rada (1996) in research comparing hypertexts is that the diversity of chatterbot design makes it hard to develop effective criteria comparison among different systems. In order to avoid that problem, we chose an experimental design that allowed the comparison between hypertext and chatterbot. The solution was to develop both the hypertext and chatterbot from the same initial text, which consisted of a number of questions and answers. Then the hypertext was structured as a FAQ and the chatterbot in its equivalent FaqBot. Both have the same repertoire of questions and the same answers. The only difference between the chatterbot and the hypertext is that the hypertext shows the list of questions with a link to the answers, and the chatterbot shows only an entry line where the user has to type free questions.

In order to have a very well delimited scope, a management situation (a case study) was presented to a group of students. They were solicited to ask some questions in order to solve the problem proposed. It was possible to collect more than 500 questions from that group of students. After that, equivalent questions were grouped, and the answers added to the FAQ database.

To evaluate the performance of each studied media (printed media, hypertext and chatterbot), a group of 56 students was divided into 3 sub-groups, one for each kind of media. Each group read the case study and interacted with only one kind of media (containing the FAQ database) in order to solve a proposed problem. After that, each student was evaluated by a discursive test with 4 questions and a multiple-choice test with 10 questions. The discursive questions were evaluated by comparison to default answers.

#### 4. ANALYSIS AND INTERPRETATION

Figure 1 analyses the students' grades in discursive questions, and shows that the chatterbot group has smaller amplitude and a higher median in grades. Students in that group were more assertive than the others. Students that used hypertext and printed media had more dispersed grades.

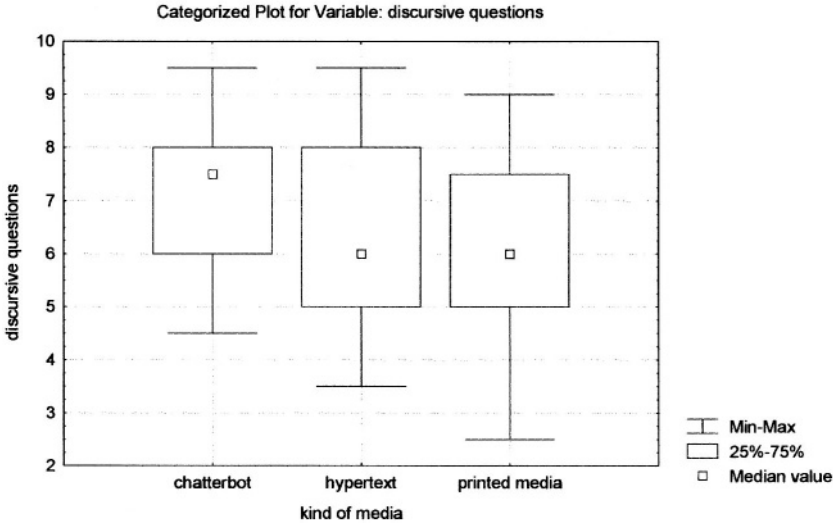

Figure 1. Box-plot for the grades in discursive questions.

Figure 2 analyses the grades obtained in multiple-choice questions. The grades obtained by the chatterbot group concentrate around the median. The hypertext group presents a greater dispersion of the grades. The printed media group shows great concentration of grades higher than 7.

The ANOVA test (Table 1) shows that the chatterbot has a significant result for discursive questions. When considering the information effectively retrieved, the chatterbot also has a significant result for multiple-choice questions.

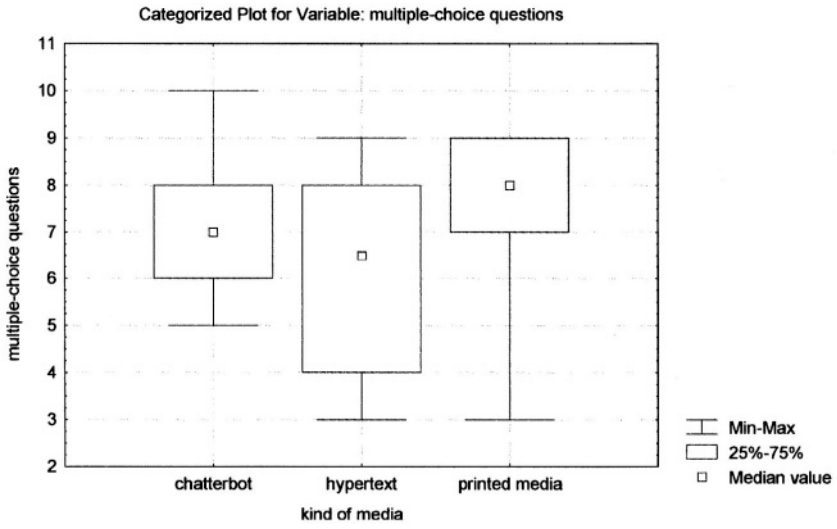

Figure 2. Box-plot for the grade in the multiple-choice questions.

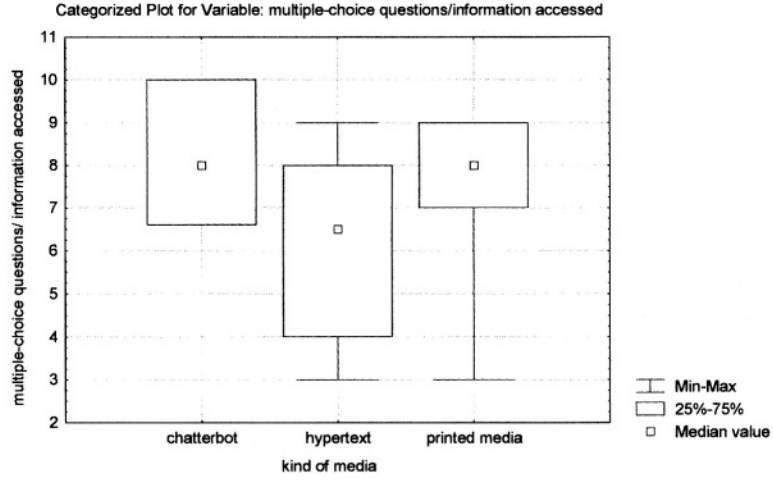

Figure 3. Box-plot for students grades in the multiple-choice questions considering only the information accessed.



*Table 1. ANOVA results for chatterbot*

	Discursive Questions	Multiple-Choice Questions	Multiple-Choice With Effectively Retrieved Information
Chatterbot	0.005	0.715	0.006

The Contrast Test was used in order to verify if the differences were statistically valid. According to Montgomery (1997), the Contrast Test is the best method for multiple comparisons between means. In this test the hypothesis are verified through linear combinations among the treatments. Table 2 summarizes the values obtained for the means.

*Table 2. Summary of students' mean scores*

	Printed media	Hypertext	Chatterbot
Discursive	5.452	6.197	7.366
Multiple-choice	6.717	6.395	6.772
Objective considering the accesses	6.717	6.395	8.246

The Contrast Test (Table 3) shows that the utilization of chatterbots increase the possibility of learning when compared to hypertext and printed media when discursive questions and retrieved information is considered.

*Table 3. Contrast Test results for chatterbot, hypertext and printed media.*

Test	Discursive questions	Retrieved information
Chatterbot x Hypertext	0.012	0.001
Chatterbot x Printed Media	0.000	0.010

## 5. CONCLUSIONS

The experiment confirmed hypotheses 1 and 2. The use of a chatterbot improves the quality of learning when compared to hypertext and printed media. Even if students retrieve less information, they retain and interpret the information in a more useful way when using the chatterbot. It was verified that students using the chatterbot provided more consistent and elaborated answers.

The experiment verified also that students had some difficulty in asking questions of the chatterbot. All of the students had 40 minutes to interact with the assigned media, and in the case of the chatterbot group, the time for

formulation of the first question averaged 7.61 minutes. Each pair of students asked an average of 16 questions in 40 minutes.

We believe that the small number of questions influenced the outcomes of the multiple-choice testing, given that the chatterbot group has relatively less information retrieved than the other two groups. However, it was observed that the process of thinking about the questions to ask to the chatterbot gave the students the ability to perform better in the discursive test.

## REFERENCES

- Chen, C., & Rada, R. (1996). Interacting with hypertext: A meta-analysis of experimental studies. *Human-Computer Interaction, 11*(2), 125-156.
- Graesser, A. C., Wiemar-Hastings, K., Wiemar-Hastings, P., & Kreuz, R. (1999). Autotutor: a simulation of a human tutor. *Journal of Cognitive Systems Research, 1*, 35-51.
- Laven, Simon. (1996). *The Simon Lavel Home Page*. Retrieved from <http://www.toptown.com/hp/sjlaven/>
- Leaverton, Michael. How Virtual Agents Make the Web More Human, in *CNET TechTrends*. Retrieved from <http://www.cnet.com/techtrends/0-1544320-8-2862007-1.html>
- Montgomery, D. C. (1997). *Design and analysis of experiments*. (4<sup>th</sup> ed.), New York: Wiley.
- Primo, A. F. T. (n.d.) *Chatterbots: Robôs de conversação*. Retrieved from <http://www.cybelle.cjb.net>

## BIOGRAPHY

Raul Sidnei Wazlawick received his Bachelor in Computer Science in 1988 and is a Doctor in Engineering (1993). He is an associate professor at the Federal University of Santa Catarina and Director of the Graduate Program on Computer Science. He is also a member of the Council of the Brazilian Computer Society and is the national representative of his country on IFIP's Technical Committee 3 (Education).

Maria José Carvalho de Souza Domingues received her Bachelor in Business Administration in 1986 and her Doctor in Industrial Engineering in 2003. She is an associate professor at the Regional University of Blumenau and Director of the Graduate Program in Business Administration.



# DEVELOPING INTERNATIONAL LEADERSHIP IN EDUCATIONAL TECHNOLOGY

## *Strategies to Promote Intercultural Competence*

Niki Davis<sup>1</sup>, Andrew Brown<sup>2</sup> and Rick Ferdig<sup>3</sup>

<sup>1</sup>Iowa State University and Institute of Education University of London UK, <sup>2</sup>Institute of Education University of London UK, <sup>3</sup>University of Florida USA

**Abstract:** Harnessing the power of new methods and new technologies is a key to renewing education to serve our diverse societies at the beginning of the twenty-first century. Doctoral education plays a pivotal role in the professional preparation of leaders for higher education, schools and related services. Drawing upon research and development in Europe and the USA, this paper describes a range of innovative strategies to promote intercultural competence. The transatlantic project *International Leadership in Educational Technology* (ILET) is building a virtual learning community. The project has confirmed our belief that communication technologies, blended with faculty collaboration and limited student travel, make potent ingredients for the preparation of the next generation of leaders of educational technology. However, the project has also dispelled any naïve beliefs as to our ability to effect widespread change in our universities. A second example project within Iowa State University used complementary strategies that developed project proposals taking ILET as one example of the use of technology for international education, including a future project to measure intercultural competence over time.

**Key words:** professional development, cultural learning, virtual learning community

## 1. INTRODUCTION

There is growing awareness of the need to develop intercultural communication and global perspectives in many countries, especially in Europe and North America. The adoption of information processing has led to global changes resulting in an urgency to increase access to educational technology (Haddad & Draxler, 2002): that access should respect our

culturally diverse world. This should involve expanding the education of educators and the training of the trainers to include intercultural perspectives, and to actively develop their intercultural communication. Martin & Nakayama (2000) identify motivating factors to improve intercultural communication:

- A technology push that links an increasing diversity of cultures reduces the effects of spatial and temporal separation.
- An economic imperative as trade and commerce, including trade in education and training, becomes increasingly global in scale and aspiration whilst maintaining the need to meet local needs and concerns.
- The personal motivation that comes with our inquisitive and exploratory nature as human beings developing self-awareness. To this we add the educational enrichment of being able to critically reflect when the familiar has become strange.
- The imperative of peace and the related demographic imperative as our societies become increasingly diverse.
- Ethical imperatives that arise from the many issues that arise with variations in beliefs and norms.

These imperatives led us to collaborate to develop a range of strategies for professional development of the next generation of leaders of educational technology. Our goal is to use the medium of E-learning to spread the message of intercultural communication, especially in education and training. A significant reconceptualization has come with the realization that aspects of culture shock also apply to online learning, especially over the web. McLuhan's (1967) concept that 'the medium is the message' is relevant; digital media are not neutral and their affordances are not always expected.

## **2. CULTURE SHOCK ONLINE**

Culture shock, which is commonly experienced by people when immersed in settings that are unfamiliar to them, has long been acknowledged as an important issue for those involved with international education. Such immersion presents both opportunities and significant risks. Universities routinely brief foreign students on their arrival from abroad on the U-curve of culture shock that they will experience. The start is an enjoyable tourist phase before culture shock with its disorientation, stress and anxiety. This is followed by adjustment as problem-solving skills develop, until stable adaptation or acculturation is achieved (Winkleman, 1994). Students are also warned to expect a similar less severe cycle on their return 'home.' Students preparing to study abroad are briefed on the

phenomenon of culture shock and occasionally work through exercises to help reduce the effect. Cultural preparation includes familiarization, before departure, with foreign artefacts and problem solving behaviors accompanied by some key words for common situations, along with appropriate body language. The process of culture shock is also relevant to our research on teacher education for distance education. For example, Niki Davis leads the development of a course for preservice and practicing teachers that prepares them to teaching using a wide range of strategies in distance education. The associated research has repetitively prototyped this course (Davis & Nilakanta, 2003). Students in this course work in groups studying cases of distance education, and the course culminates in a group project to develop their own authentic case of distance education. All or most of the course takes place in a distance learning mode using WebCT. Students find this to be very stimulating and engaging by the end of the course, and it is not unusual to find that some students wish to continue using WebCT beyond the end of semester. However, some students seem to experience elation in the early stage, followed by anxiety during which they complain about feelings of disorientation in the online classroom.

Our work to reduce culture shock for students studying abroad, has suggested to us that this emotional reaction to web-based learning may be a form of culture shock. This is supported by the literature that describes online environments in cultural terms and the term “cyberculture” (see Bonk & King, 1998 for example). This common need to address culture shock for both eLearning and for the development of intercultural competence provides the authors of this paper with a shared focus to the two projects discussed in this paper. The first project involves a transatlantic consortium applying eLearning to doctoral education. The second project promoted the development of international projects within one university in the USA.

### **3. OUR TRANSATLANTIC PARTNERSHIP**

The ILET project brings together doctoral students, faculty and staff to create an international and intercultural doctoral research and development community in educational technology in six universities; three in Europe and three in the United States. A major motivation for this project is the recognition that, whilst researchers and leaders in the use of educational technology are working in contexts that are increasingly culturally diverse, we have done little to prepare them for this. The idea of membership of and immersion in a community of researchers is central to both the European and North American notions of doctoral level study and provided, from our viewpoint, an ideal starting point for such a preparation. The extent of a

doctoral research community is potentially huge with the use of synchronous and asynchronous communication technologies, such as email, video and text conferencing and virtual learning environments, plus the dissemination of research via the web.

Our engagement in this globally connected, but spatially and temporally distanced community, with none of the immediate existential communicative imperatives of physical immersion, can too often be from a culturally fixed and non-reflexive position. Thus the challenge facing the six participating universities is how to create contexts for intercultural interchange and interaction in which reflection on the very processes of this engagement is facilitated, and the implications are critically considered. Our aim is for all involved to be able to engage in intercultural interactions in academic and professional contexts with greater understanding, and to relate this to the development of knowledge and practice in the areas of our expertise.

One of the project's major objectives is to enable doctoral students from the USA and our European partner universities to spend one semester abroad at a project member university. This will have a profound effect on the individuals involved and begins to have an effect on the institutions on both sides of the Atlantic. Much time and effort clearly has to be given to preparation of students to make the most of this kind of experience. We have created online and other digital resources for cultural preparation and recruitment. To extend the benefits of the developing partnership between universities to students who are not intending or unable to travel, we have also developed a range of online seminars and reading groups. Our intention is to develop from this a clearer understanding of how to facilitate advanced learning and knowledge production in intercultural contexts, both face-to-face and virtual. The first step in this process involved the development of mutual understanding between the staff involved in the project.

Having to develop a common understanding of educational technology, and to create the conditions for research students to cross the Atlantic, involved an exchange of perspectives and a growing understanding of the differences in our programmes and their underlying assumptions. Expectations of doctoral students are very different both within Europe and between Europe and the USA (Brown & Dowling, 1998). If we are to facilitate mobility and productive interchange, we have to find ways to understand and handle these differences.

Our initial collaboration resulted in the production of a six way Memorandum on Understanding between the partner universities. This has laid the foundations for both movement of staff and doctoral students between the universities and the creation of a range of experiences that incorporate intercultural communication on the web, such as our series of transatlantic reading groups and opportunities to join web-based courses run

at other universities. These, too, provide rich intercultural experiences and also present the possibility of culture shock. Their strength is that they provide a legitimate opportunity to reflect upon issues relating to cultural diversity in computer-mediated contexts. These courses and seminars, thus, both take communication technology as a focus and use it to enable intercultural interaction. This interaction in turn becomes a legitimate focus for discussion, which facilitates critical reflection on the relationship between cultural and linguistic diversity, and the characteristics and consequences of different forms of computer-mediated interaction. Online academic and professional discussions can, for instance, be every bit as socially and culturally differentiating and excluding as face-to-face encounters. The web-based component of the project enables us to explore the relationship between culture and factors such as the content of the curriculum, forms of pedagogy and the structuring and characteristics of the online environment. We have found, for instance, within the group there are strong commitments to particular educational ideologies, which relate to the cultural background of participants, and these impact on the form of online environment in which people feel most comfortable. Virtual study abroad raises many of the same issues as physical study abroad. Given the increasing ease of access to opportunities to 'study abroad' online, and the degree to which interaction on the web is increasingly intercultural, these issues become ever more pressing.

In recognition of the value of these experiences, both for individuals and institutions, we have extended our planned Certificate in Intercultural Educational Technology to include doctoral students who participate in the web-based activities and who provide mentoring and support for those who are able to take up the opportunity to travel. All participants will have the opportunity to develop reflective accounts of their intercultural experiences and develop these into an ePortfolio that can be submitted for the award of the Certificate. Since the initiation of the ILET project in autumn 2001, we have been building a rich collection of publicly available resources on the web to support faculty and participating doctoral students (<http://www.public.iastate.edu/~ilet>). We intend to add edited material from the ePortfolios to the ILET web site, thus supplementing our developing collection of eLearning resources with the best student material. In autumn 2002 the web site provided the home for the project's first international reading group, during which online discussions moved across professional and university E-forums on both sides of the Atlantic. The first virtual exchanges and team teaching took place and were followed by a second reading group in which readings were discussed in Spanish to establish the two main languages of the project. More are planned for the coming year.



With the dominance of English on the web, the project is keen to support students' growing appreciation of minority languages. Danish and Catalan partners, at Aalborg University and the University of Barcelona, have been working to support study abroad by developing flexible web-based learning materials, covering culture and language. For example, in autumn 2002 two Danish interns at Iowa State University led the development of Danish materials supported by ISU students studying distance education.

An intensive course, on site in June 2003 at the Institute of Education focused on international issues in educational technology and involved students and faculty from all partner universities. It provided the opportunity to blend on site learning with eLearning and to develop links that will develop into internships and longer-term partnerships between EU and US faculty and doctoral students. In autumn 2003 the next key development occurs when the first doctoral students undertake transatlantic internships. These students will be the first ILET future leaders to become interns in higher education abroad, while continuing their doctoral research.

#### **4. ORGANIZATIONAL CHANGE IN A UNIVERSITY**

The ILET project has confirmed our belief that communication technologies, blended with faculty collaboration and limited student travel, make potent ingredients for the preparation of the next generation of leaders of educational technology. However, it has also dispelled any naïve beliefs as to our ability to effect widespread change in our universities, and we recognize that there will be significant challenges to sustaining and expanding our international collaboration. Universities have been termed 'organized anarchies' with local academic freedoms within traditional broad reaching legacy structures that are notoriously difficult to change.

The first author successfully led colleagues in a project to deliver workshops in planning international projects that would incorporate communication technologies to support their goals. The first workshop used project descriptions, including ILET described above, to stimulate more than six grant planning teams, which incorporated the experience of both US faculty (with academic expertise) and international graduate students (with specific international expertise). A second workshop developed an outline proposal for an overarching project to understand the ways in which the developing intercultural competence enhances higher education and later professional practice.

This future project would create tools and strategies to measure student and faculty development through the phases of culture shock with use of the

web as a net to collect data from many international programs while simultaneously providing ongoing dissemination. The survey instrument would also be designed to promote the process of intercultural competence. The second data collection method proposed is the use of student-generated teleographies. Howard (1996) used the word teleography to define future fictional autobiographies. If an autobiography tells the story of the past, a teleography tells the story of a future and provides a guide for that individual. Students will be requested to write teleographies before and after intercultural experience, plus a final summary of their perspectives on the change. These artefacts will allow us to measure growth in various areas (Ferdig, 2002). The sharing of these teleographies between participants is likely to promote intercultural competence and to improve our understanding of this process. The ILET project team plans to pilot this research.

## **5. SUMMARY**

This paper has described ongoing research and development of an international interdisciplinary community of researchers, students and professionals committed to the appropriate development of the next generation of leaders of educational technology. Such leaders should become competent for the intercultural contexts in which they will work and model good practice for those they lead and teach.

The range of strategies that we are continuing to research and develop includes plans for both traditional and novel approaches for the measurement of intercultural competence. We have also identified a new perspective on eLearning and eTraining; namely, that culture shock occurs in distance learning and measures to manage that shock have a potentially symbiotic relationship with intercultural learning.

Although simple answers are not predicted, because we understand that we are engineering change in complex and networked educational systems (Davis 2002), the quest to promote and measure intercultural competence and to expedite successful practice enhanced with new technologies is a worthy goal motivated by the same factors that motivate those who promote intercultural communication, most notably the promotion of peace, ethics and economy, plus personal and professional development.

## **REFERENCES**

- Bonk, C. J. & King, K. S. (1998). *Electronic Collaborators: Learner-Centered Technologies for Literacy, Apprenticeship, and Discourse*. Erlbaum.

- Brown, A. & Dowling P. (1998). *Doing research/reading research: a mode of interrogation for education*. London: Falmer.
- Davis, N. E., (2002). Leadership of information technology for teacher education: a discussion of complex systems with dynamic models to inform shared leadership. *Journal of Information Technology for Teacher Education*, 11, 253-271.
- Davis, N. E., & Nilakanta, R. (2003). Quality @ a distance includes preservice teachers: one case- and project-based approach. In E. Stacey & G. Davies, (Eds.) *Quality Education @ a Distance*. Amsterdam: Kluwer Press.
- Ferdig, R. (1998). *Teaching a teacher about technology: a narrative approach*. Paper presented at the annual conference of the Society of Information Technology and Teacher Education, Washington DC, March.
- Haddad, W. & Draxler A., (Eds). (2003) *Technologies For Education: Potential, parameters and prospects*, UNESCO and Academy for Educational Development [online] <http://www.aed.org/publications/TechEdInfo.html>
- Howard, G. S. (1996). *Understanding human nature: an owner's manual*. Notre Dame Indiana: Academic Publications.
- Martin, J. N. & Nakayama, T. K. (2000). *Intercultural Communication in Contexts*. (2<sup>nd</sup> ed.) Mountain View, CA: Mayfield Publishing Company.
- McLuhan, M. (1967). *The Medium is the Message*. New York: Bantam.
- Winkleman, M. (1994). Culture shock and adaptation. *Journal of Counselling and Development*, 73, 121-127.

## BIOGRAPHY

Niki Davis has research interests in both teacher education and distance education. Recent research has focused the identification and development of good practice with information technology in preservice teacher education and in distance education more generally. She is the current chair of IFIP Working Group 3.3 for Research. Andrew Brown's research interests include the development of doctoral education. Rick Ferdig's research interests include development of multimedia on the Internet to improve the teaching of reading.

## ACKNOWLEDGMENTS

We would like to thank ISU colleagues including Stephen Freeman, Lynn Jones, Donna Kiensler, James Mcshay and Victor Udin. The paper and a related project are supported by funds provided in Europe by the Directorate General for Education and Culture (DG EAC) and a grant from the US Department of Education (FIPSE) and the consortium members. The paper does not necessarily represent the policy of the Department of Education, and you should not assume endorsement by the US Federal Government or DG EAC.

# **DISTANCE LEARNING APPROACHES IN TEACHER TRAINING**

## *Variables Related To Teacher-Training Students' Preferences*

Yaacov J. Katz

*School of Education, Bar-Ilan University, Ramat-Gan 52900, Israel. katzya@mail.biu.ac.il*

**Abstract:** Forty two teacher-training students participated in a 60 hour, year long teacher-training course that used two different distance learning approaches. Students worked in the first semester with synchronous Picture-Tel® videoconferencing, and in second semester with an asynchronous Internet based course. Their comparative satisfaction with each delivery system, and their comparative level of control of the learning process were examined. Results indicate that the interactive and asynchronous Internet Distance Learning approach contributes to a significantly higher level of satisfaction and higher level of control of the learning process than the interactive synchronous system. It is suggested that when the issue of introducing Distance Learning at the college level for teacher-training students is addressed, it is preferable to install an interactive Internet type method rather than a Picture-Tel® type system in order to best promote student satisfaction as well as student level of control of the learning situation.

**Key words:** distance learning, Internet, level of control, satisfaction, videoconference

## **1. DISTANCE LEARNING**

The steady evolution of Information and Communication Technology (radio, television, interactive video, electronic mail, Internet and intranet) has influenced the development of Distance Learning (DL) at the tertiary level (McCullagh & Stacey, 1993). In the wake of the development of sophisticated third generation DL systems—which superseded previous DL approaches, and include interactive video, email, Internet, and intranet technologies—learning activity through the medium of these state-of-the-art DL systems has been redefined to include and focus on interactivity between

teachers and students (Trentin, 1997). Interactive videoconferencing, and interaction through the medium of Internet or intranet, offer one-to-many or one-to-one tuition in which teachers and students are able to communicate on-line thereby solving key instructional and learning problems in real time (Katz, 1998). Third generation DL systems are flexible and present teachers with the opportunity of continuously monitoring their students' overall progress. Carswell & Venkatesh (2002), Davies & Quick (2001), and Hwang, Shiu, Wu & Li (2002) indicated that, in particular, third generation systems that incorporate asynchronous features promote quality learning because of the flexibility of the system and the ability of the learners to learn according to their own personal schedule: an advantage not available in a synchronous system.

## **2. STUDENT SATISFACTION AND STUDENT CONTROL OF THE LEARNING PROCESS**

Two major affective variables related to the instructional and learning processes are student satisfaction with learning, and student control of the learning process. Katz (1998) confirmed previous findings that student satisfaction with instructional and learning approaches is related to positive motivation to learn, as well as to higher levels of achievement. Katz pointed out that one of the key issues that contributes to student satisfaction is the level of interactivity present in the instructional and learning processes. Higher levels of interaction contribute to a higher rate of satisfaction as well as to higher levels of achievement.

In an additional study Katz (1994) examined the importance of student control of the learning process vis-à-vis the use of information technology as an instructional and learning methodology. Katz indicated that students who felt that they were in control of the learning process had more positive attitudes towards the use of information technology as an instructional and learning methodology and were more open to the use of computer-based approaches in the course of their studies than students who felt that they did not control the instructional and learning process.

## **3. UNIVERSITY AND SATELLITE COLLEGE DISTANCE LEARNING SYSTEMS**

In Israel, a growing number of satellite university colleges have been established in peripheral towns and regional centers in order to cater for the

growing needs of the population. These colleges comply with the rigorous academic standards maintained by the sponsoring universities. However, there is a pronounced scarcity of fully qualified academic faculty members who are willing to teach at satellite colleges situated in towns geographically removed from the center of the country.

In order to overcome this problem the Bar-Ilan University established a sophisticated third generation DL system that connects the main university campus, with the Safed Regional College campus located 250 km. north of the university. The DL system connecting the university to the college incorporates two different interactive DL approaches. The first DL approach uses a synchronous Picture-Tel® interactive video system (Katz, 1998) that allows teachers and students situated in different locations to interact with each other in a situation similar to that existing in a traditional lecture hall. The second DL approach is based on interactive asynchronous Internet-based learning (Glave, 1998) through which coursework, generated at the main university campus, is presented to the students situated at the satellite campus or at their homes. In addition, the Internet system allows for asynchronous contact between the teacher who can enter an Internet forum connected to the course in order to view students' comments and requests. Both Picture-Tel® and Internet technologies are augmented by an email system available to teachers and students for communication in between lectures.

#### **4. AIM OF THE RESEARCH PROJECT**

The aims of this study were to examine teacher-training students' satisfaction with the synchronous Picture-Tel® videoconference and the asynchronous Internet Distance Learning systems that linked the Bar-Ilan University and the Safed Regional College, as well as to compare the level of control of the learning process experienced by teacher-training students who participated in the year-long 'Introduction to Teacher-Training' course, delivered by the two DL approaches.

#### **5. METHOD**

##### **5.1 Sample**

The research sample consisted of 42 first year teacher-training students who were registered in the School of Education at the Safed Regional

College. All of the students were accepted for study at the School of Education on the basis of two main criteria: a) achievement level attained in high school matriculation examinations, and b) college entrance psychometric examination scores. At the beginning of the 2002-2003 academic year, all 42 students registered for the mandatory 'Introduction to Teacher-Training' course. During the 15 week-long (30 hours) first semester, the 42 students studied through the medium of the synchronous Picture-Tel® DL videoconference system. During the 15 week-long (30 hours) second semester the students continued their studies in the same course through the medium of an asynchronous Internet approach as the course DL delivery platform. A senior lecturer was responsible for both semesters of the course and was fully familiar with instruction and learning through both the Picture-Tel® and Internet DL approaches.

## **5.2 Instruments**

The Students' Satisfaction Questionnaire (Katz, 1998) is a 15 item questionnaire designed to examine the teacher-training students' satisfaction with DL systems. It was evaluated by three ICT educational experts and was adjudged to have face validity. The students' responses to the questionnaire items were factor analyzed in a principal components analysis. Eight items met the criterion of statistical significance (0.30) and were used in the statistical analysis of the research data. These items clustered around one significant factor that was labelled 'Student Satisfaction with Distance Learning'. This factor had a latent root of unity, and explained at least 10% of the variance. The alpha reliability coefficient of the 'Student Satisfaction with Distance Learning' variable in the present study reached the 0.91 level.

The Students' Level of Control of Learning Questionnaire is also a 15 item questionnaire designed to examine the students' feelings about their level of control of the learning process. It was evaluated by three ICT educational experts and was adjudged to have face validity. The students' responses to the questionnaire items were factor analyzed in a principal components analysis. Eleven items met the criterion of statistical significance (0.30) and were used in the statistical analysis of the research data. The 11 items clustered around 1 significant factor that was labeled "Level of Control of Learning". This factor had a latent root of unity and explained at least 10% of the variance. The alpha reliability coefficient of the "Level of Control of Learning" variable in the present study reached the 0.86 level.

The two research instruments were administered to the students at the end of the first semester of the 2002-2003 academic year to examine their satisfaction and level of control of the learning process after studying by way

of the Picture-Tel® DL configuration and again at the end of the second semester of the same academic year in order to examine their satisfaction and level of control after studying through the medium of the interactive Internet DL approach.

### 5.3 Procedure

During the first semester, the synchronous Picture-Tel® DL system was used to deliver weekly lectures to the 42 students in a suitably equipped lecture hall at the Safed college campus. During the second semester the students were able to login asynchronously to the Internet based course at any time from their homes or from the college. The course included lectures, relevant texts and revision exercises. In addition they could log in synchronously to Internet chat and forum sessions held by the lecturer for those who needed additional assistance with their coursework. During both semesters all participating students were required to communicate at least once weekly with the lecturer by way of email as a secondary and complementary learning methodology.

## 6. RESULTS

Means and standard deviations for the ‘Student Satisfaction with Distance Learning’ variable for each Distance Learning methodology were computed from data collected from the research questionnaire administered to students who participated in the year-long Introduction to Teacher-Training course. Thereafter student scores for the Student Satisfaction with Distance Learning variable for each Distance Learning methodology were compared in a paired samples t-test. Descriptive data and paired samples t-test results are presented in Table. 1.

Table 1. T-test results (paired samples) on Student Satisfaction with Distance Learning Variable (N=42)

D.L. Methodology	N	Mean	S.D.	D.F.	t	P
Internet	42	33.11	3.10	41	5.96	P<0.001
Picture-Tel®	42	28.47	3.98			



From the results of the t-test, the existence of a significantly higher level of student satisfaction with the Internet-based methodology is indicated on the 'Student Satisfaction with Distance Learning' variable. It is apparent that the Internet-based learning system engendered a significantly higher level of satisfaction among the students than the level of satisfaction derived from the Picture Tel® videoconference system.

Means and standard deviations were computed for the 'Level of Control of Learning' variable for each DL methodology. Thereafter, student scores for the Level of Control of Learning variable for each DL methodology were compared in a paired samples t-test. Descriptive data and paired samples t-test results are presented below in Table 2.

*Table 2. T-test results (paired samples) on Level of Control of Learning Variable (N=42)*

D.L. Methodology	N	Mean	S.D.	D.F.	t	P
Internet	42	38.69	4.59	41	4.88	P<0.001
Picture-Tel®	42	35.30	3.77			

From the results of the t-test the existence of a significantly higher level of control by teacher-training students is indicated on the 'Level of Control of Learning' variable when DL instruction was conducted through an Internet-based approach. It is apparent that the Internet-based approach engendered an enhanced feeling of control of learning among teacher-training students that was significantly higher than the level of control of learning perceived when studying through the medium of Picture-Tel® Distance Learning methodology.

## 7. DISCUSSION

It is apparent that during the second semester study in the course that used an asynchronous Internet-based DL methodology, the students were significantly more satisfied with the learning and instructional process than they were during first semester study which was used the synchronous Picture-Tel® DL system. It appears that the asynchronous Internet-based approach, which is sophisticated and highly interactive but flexible and suited to the students' personal schedules, allows tutors and students with instructional and learning opportunities to better deal with the study material than those presented by the synchronous Picture-Tel® system. While this closely resembles a regular classroom, it is not flexible in accommodating

the students' personal schedules. Those students who studied through the videoconference-based course indicated a lower level of satisfaction with this mode of study than those utilizing the Internet methodology. This is probably because the student-teacher interaction is more flexible and intense in an Internet course. The Internet DL approach apparently offers learning and instructional advantages because of the intensity of the asynchronous interaction between students and teachers. As a result, it seems that the students are more reserved about their level of satisfaction with the synchronous Picture-Tel® videoconference system than with the Internet-based methodology.

Additional statistical analysis indicates that the students' feelings about the Level of Control of Learning variable were significantly more positive when they studied the course during the second semester through the use of Internet-based DL method than when they studied the same course during the first semester through the Picture-Tel® DL system. It appears that the asynchronous Internet-based approach contributes to a more flexible, natural and relaxed instructional and learning atmosphere which in turn leads to a feeling of more comprehensive control of the learning process than that generated through the synchronous Picture-Tel® DL approach which is apparently compromised somewhat by objective technological limitations. The perception of the students that the Internet-based system allows for more flexible and intensive student-teacher interaction conceivably leads them to feel a greater measure of control of the learning process than when study is conducted through a synchronous medium such as with the Picture-Tel® videoconference system.

## **8. CONCLUSION**

The results show that a flexible and interactive asynchronous DL system that allows for intensive student-teacher interaction is best. It is also best suited to contribute significantly to student satisfaction, and to a feeling of control of the learning process. Systems that provide synchronous interaction, and which may be between teacher-training students and their instructors are less able to engender either student satisfaction or a feeling of control of learning. The present study clearly indicates the comparative advantages of an Internet-based asynchronous approach over a Picture-Tel® type synchronous videoconference configuration. Thus, despite the heavier work-load associated with using an asynchronous Internet based system, the Internet based system is more highly recommended as a Distance Learning approach than the videoconference-based learning method.

## REFERENCES

- Carswell, A. D. & Venkatesh, V. (2002). Learner outcomes in an asynchronous distance education environment. *Int. Journal of Human Computer Studies*, 56(5), 475-494.
- Davies, T. G., & Quick, D. (2001). Reducing distance through Distance Learning: the community college leadership doctoral program at Colorado State University Community College. *Journal of Research and Practice*, 25(8), 607-620.
- Glave, J. (1998). Dramatic Internet growth continues. *Wired News*. (online) <http://www.com/news/news/email/other/technology/story/10323.html>.
- Hwang, W., Shiu, R., Wu, S., & Li, C. (2002). An exploration of learning ability transition and material information. *Journal of Educational Computing Research*, 26(3), 301-324.
- Katz, Y. J. (1994). Self-image, locus of control and computer-related attitudes. In R. Lewis and P. Mendelsohn (Eds.), *Lessons from learning*. Amsterdam: Elsevier.
- Katz, Y. J. (1998). The relationship between distance learning methods and satisfaction and achievement of college students. In G. Davies (Ed.), *Teleteaching '98: Distance learning, training and education*. Vienna, OCG and IFIP.
- McCullagh, W. & Stacey, E. (1993). Telematics implications for Teacher Education. In G. Davies and B. Samways (Eds.), *Teleteaching*. Amsterdam: Elsevier.
- Trentin, G. (1997). Telematics and on-line teacher-training: the POLARIS project. *Journal of Computer Assisted Learning*, 13, 261-270.

## BIOGRAPHY

Professor Yaacov Katz is the Director of the Institute for Community Education and Research at Bar-Ilan University and Chair of the Pedagogic Secretariat of the Israeli Ministry of Education, Culture and Sport. He specializes in research on the attitudes of students and teachers towards the use of ICT in Education and has published widely in this area.

# **Building Technology-Based Training on Relevant Learning Perspectives**

Timo Lainema

*Turku School of Economics and Business Administration*

**Abstract:** Today, much of the work within technology-based learning use constructivism as a reference ‘discipline’ but few of the work done within the field discusses thoroughly, what are the basic assumptions and implications of constructivism. As a result, the technology has driven the applications, with theory only vaguely or superficially applied. Constructivism provides one theoretical approach to the use of computer-based learning systems. In this paper we discuss how constructivism adds value on technology-based learning discussion. Going through these different views will introduce how our understanding of technology based learning and the role of the learner in this process has changed during the last two decades.

**Key words:** Collaborative Learning, Learner Centered Learning, Teaching Methods.

## **1. INTRODUCTION**

Jonassen and Land (2000) note that during the 1990’s we have witnessed a convergence of learning theories never before encountered. These contemporary learning theories are based on substantially different ontologies and epistemologies than what used to be the traditional objectivist foundations for instructional design. However, much of the discussion on higher education has been about markets and applications, and very little is said about learning. We are interested in constructivism because it seems to give a lot of suggestions about how to construct computer-based (e-learning) environments.

Constructivism is a view of learning that emerges from the discipline of Education. It is a set of principles that can be applied also when designing

computer-based instructions. Principles often mentioned in relation to constructivism are, for example: all learning is a process of construction; knowledge is context dependent and learning should occur in contexts to which it is relevant; learning is an inherently social-dialogical activity grounded in talk; learners are participants in a sociocultural process.

Bednar et al. (1992) argue that in the field of instructional systems technology it has been appropriate to select principles and techniques from many theoretical perspectives, choosing those we like best and ending up with a design technology based on no single theoretical base. Thus, concepts and strategies are abstracted out of their theoretical framework. However, effective instructional design emerges from the deliberate application of some particular theory of learning.

Before introducing constructivism, we briefly discuss experiential learning. Experiential learning theory is one of the most influential theories of management learning. Experientialism and constructivism have a lot in common. Just to mention one similarity, these views refer to Dewey, Piaget, and Lewin as their original authors. We see these views of learning as supporting and supplementing each other. Together they give us an enlarged understanding of learning through experimentation and on the basis of that give us more capabilities to study and analyze learning.

## **2. EXPERIENTIAL LEARNING**

Experiential learning theory points to the significance of learning through direct experience as opposed to learning through 'instruction'. The learners act as decision-makers and see the consequences of their decisions. An important aspect of this view is that learning occurs through the resolution of conflicts. However, in the real world, learning from experience is not that self-evident. Actions taken in one area may have significant effects in distant parts of the system, but these effects may be obscure to the original actors. Thus, decision-makers cannot see the consequences of their decisions. This supports the use of learning environments that represent causal relationships and where time is accelerated: the link between a decision and its outcomes becomes explicit.

Kolb (1984) notes two aspects of the experiential learning model. The first one is the emphasis on here-and-now concrete experience to validate and test abstract concepts. Immediate personal experience is the focal point for learning. This experience gives life, texture, and subjective personal meaning to abstract concepts and at the same time provides a concrete, publicly shared reference point for testing the implications and validity of ideas created during the learning process. The second aspect that Kolb

emphasizes in this learning model is that training is based on feedback processes. The information feedback provides the basis for a continuous process of goal-directed action and the evaluation of the consequences of that action. Argyris and Schön (1978) have described a model where the process moves from discovery of problems, to invention of solutions, to production of solutions in action, to reflection on the impact of these actions, and then back to discovery (Figure 1).

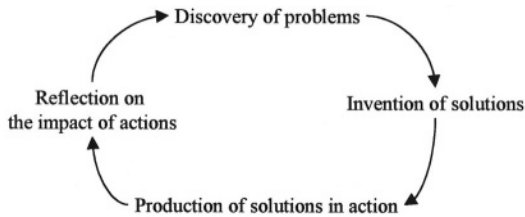

Figure 1. Learning cycle by Argyris and Schön (1978).

But this ideal learning cycle fails to operate effectively in organizations because of limits at each of the points in the cycle that are connected to everyday work activities and decision-making processes (Isaacs and Senge, 1992). These limits may cause, for example, the delays between when decisions are made and their impact to be very long. In general, these delays make it more difficult for the decision-makers to see the outcomes of their decisions.

Experiential learning environments receive support also from the field of organizational learning (OL). Some central concepts in OL are single- and double-loop learning (Argyris and Schön, 1996), which explain why it is often so difficult to achieve real change in individuals. Single-loop learning (SLL) is instrumental learning that changes strategies of action or assumptions underlying strategies in ways that leave the values of a theory of action unchanged. Double-loop learning (DLL) results in a change in the values of theory-in-use, as well as in its strategies and assumptions. SLL is sufficient when error correction can proceed by changing strategies and assumptions within a constant framework of values and norms. It is instrumental and concerned primarily with effectiveness. In some cases, however, the correction of error requires inquiry through which organizational values and norms themselves are modified.

Villegas (1997) describes the process of experimenting with a computer-based learning environment (CBLE) as follows (Figure 2). The participants might experience 'aha effects' which are indicators that they have found

something unexpected in the CBLE. To correct this discrepancy the participants use their present mental model (SLL). During the process of trial and error the participants may notice that the discrepancies cannot be explained with their existing mental models. They may reach a better understanding of the problems exhibited in the CBLE and consequently a better insight into the real-world system (thus, modify their mental model to better represent the actual nature of the real-world system). If they change the way they explain a certain situation or realize how the real system works, they have improved their mental models and DDL has taken place.

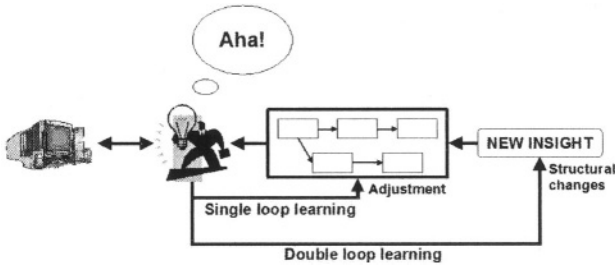

Figure 2. Individual single and double loop learning based on experimentation with a learning environment (Villegas, 1997).

As a CBLE is placed to the learning cycle introduced in Figure 1 the result is the cycle in Figure 3. Here Isaacs and Senge (1992) use the term ‘virtual world’ by Argyris and Schön instead of CBLE. This figure illustrates how a CBLE can turn visible the learning limits that are obscure in real world. CBLEs provide a rapid, unambiguous, and systemic feedback on actions taken. They provide a relatively low-risk setting in which differences in mental models can be explored. CBLEs can reflect back previously tacit assumptions and can provide insights into the nature of the complex interactions that determine the consequences of decisions.



Figure 3. The impact on learning using virtual world (Isaacs and Senge, 1992).

### 3. CONSTRUCTIVISM

Also constructivism supports experience as a source of learning and team-based learning, but it further expands and explains the characteristics of successful technology-based learning environments. To our mind constructivism is not in conflict with experiential learning. Constructivism more like complements the available toolkit of explaining how to create successful learning environments. As noted, experience has a central position in the constructivist view.

Today’s ways of understanding learning can be appreciated only against the historical background of thoughts on human learning and in relation to one another. All the theories still remain a vital part of the way we think. Unlike many other scientific theories, learning theories are generally not replaced by superior ones, but rather incorporated into subsequent theories. The most influential theories have been behaviourism and cognitive psychology (Lehtinen & Kuusinen, 2001).

One way of looking at different views on learning is described by Duffy and Jonassen (1992). The objectivist tradition acknowledges that people have different understandings based on differing experiences. However, the impact of prior experience and human interpretation is seen as leading to partial understandings and biased understandings. The goal here is to strive for the complete and correct understanding. Knowledge is believed to exist independently of instruction and there is no need to look at the instructional activities to see what is learned. The objectivist epistemology underlies Behaviourism and much of cognitive psychology. Another way of thinking about learning is constructivism, which we will describe in the following.



Bednar et al. (1992) state that the aim of using learning environments should be to facilitate situating cognition in real-world contexts, teaching through cognitive apprenticeship, and construction of multiple perspectives. By real-world contexts Bednar et al. mean that the task is not isolated but rather a part of a larger context. We should create environments that capture a larger context in which the problems are relevant. Also the reason for solving the problems must be authentic to the context in which the learning is to be applied. The environmental context is critical. The learning context forms an inexorable link with the knowledge embedded within it. Thus, an abstract, simplified environment is not just quantitatively different from the real-world environment but it is also qualitatively different. Authentic learning environments may be expected to vary in complexity with the expertise of the learner.

The authenticity argument receives support from Spiro et al. (1991). A common thread running through the deficiencies in learning is oversimplification. Compartmentalization of knowledge components works as an effective strategy in well-structured domains, but blocks effective learning in more intertwined, ill-structured domains that require high degrees of knowledge interconnectedness. Ill-structured domains require multiple representations for full coverage. Spiro et al. found that a single analogy may help at early stages of learning, but actually interferes with more advanced treatments of the same concept, when the knowledge domain is more intertwined and ill-structured requiring high degrees of knowledge interconnectedness.

Spiro et al. (1991) argue that revisiting the same material, at different times, in rearranged contexts, for different purposes and from different conceptual perspectives is essential for attaining the goals of advanced knowledge acquisition. Content must be covered more than once for full understanding because of psychological demands resulting from the complexity of case in ill-structured domains. Re-examining a case in the context of comparison with a case different from the comparison context will lead to new insights.

Duffy and Cunningham (1996) present and justify their version of Constructivism in a paper often referred to in the field of education:

- All knowledge is constructed; all learning is a process of construction. Learning is a matter of changes in one's relation to the culture to which one is connected.
- Many world views can be constructed; hence there will be multiple perspectives. The engagement with others creates the awareness of multiple perspectives.
- Knowledge is context dependent, so learning should occur in contexts to which it is relevant.

- Learning is mediated by tools and signs. All distinctly human instances of learning are constructions situated within a context that employs some form of mediational means, tools, and/or signs.
- Learning is an inherently social-dialogical activity. Knowledge, and thereby learning, is a social, communicative, and discursive process, inexorably grounded in talk.
- Learners are distributed, multidimensional participants in a sociocultural process. A distributed concept of self shifts the activity of learning to the connections one has with communities, to the patterns of participation, and away from efficient internalization of knowledge.
- We are generally unaware of the beliefs we have adopted or created to live and teach by; raising them to awareness can have salutary effects.

Duffy and Cunningham (1996) describe problem-based learning, which they feel exemplifies the constructivist theory. The focus should be on developing the skills related to solving the problem as well as other problems like it. Skills are developed through working on the problem, i.e. through authentic activity. It is impossible to describe what is learned in terms of the activity alone or in terms of the content alone, rather, it is the activity in relation to the content that defines learning. The teacher does not teach students what they should do/know and when they should do/know it. Rather, the teacher supports the students in developing their critical thinking skills, self-directed learning skills, and content knowledge in relation to the problem.

#### **4. CONCLUSIONS**

Today, the basic principles of Constructivism seem to be more or less established: Technologies can support learning if they are used as tools that help learners to think. However, effective technology-based learning environments are hard to find. According to constructivism we should create projects or environments that capture a larger context in which the problems are relevant. So, what are constructivist learning environments (CLEs)?

Jonassen et al. (1999) find this question to be a difficult one to answer. They state that CLEs are technology-based environments, in which students explore, experiment, construct, converse, and reflect on what they are doing, so that they learn from their experiences. Learners are presented with a complex and relevant problem, project, or experience that they accept or reject as a challenge. Then the CLE provides them with the tools and resources that they need to understand the problem and to solve it (or attempt to solve it). Jonassen et al. describe the components needed in successful CLEs:

- Problem/project space: learners are presented with an interesting, relevant, and engaging problem to solve. The problem should be complex and somewhat ill-defined and based on a real-world situation.
- Related cases: When expecting the learners to solve problems, it is important for the learning environment to provide access to a set of related experiences on which the learners can draw. This supports learning by representing complexity (multiple perspectives).
- Conversation (knowledge-negotiation) tools, to support collaboration.
- Social/contextual support: The weakest part of the process of instructional design has been the implementation of the technology. This is because the innovators fail to consider physical environment or social, organizational, and cultural aspects of the environment.

Constructivism is clearly a topic that needs to be studied further in the field of computer-based learning environments.

## REFERENCES

- Argyris, C., & Schön, D. (1978). *Organizational Learning: A Theory of Action Perspective*. Massachusetts: Addison Wesley.
- Argyris, C., & Schön, D. (1996). *Organizational Learning II: Theory, Method, and Practise*. Massachusetts: Addison Wesley.
- Bednar, A. K., et al. (1992). Theory into Practice: How Do We Link? In T. Duffy & D. H. Jonassen (Eds.) *Constructivism and the Technology of Instruction*. (pp.17-34). Mahwah, NJ: Lawrence Erlbaum Associates.
- Duffy, T. M., & Cunningham, D. J. (1996). Constructivism: Implications for the Design and Delivery of Instruction. In D. H. Jonassen (Ed.) *Handbook of Research for Educational Communications and Technology*. (pp. 170-198). Macmillan, New York.
- Isaacs, W. & Senge, P. (1992). Overcoming limits to learning in computer-based learning environments. *European Journal of Operational Research*, 59, 183-196.
- Jonassen, D. H. (1992). Evaluating Constructivist Learning., In T. Duffy & D. H. Jonassen (Eds.) *Constructivism and the Technology of Instruction*. (pp. 137-148). Mahwah, NJ: Lawrence Erlbaum Associates.
- Jonassen, D. H., & Land, S. (2002). Preface. In D. Jonassen & S. Land (Eds.) *Theoretical Foundations of Learning Environment*. Mahwah, NJ: Lawrence Erlbaum Associates.
- Jonassen, D. H., Peck, K. L., & Wilson, B. G. (1999). *Learning with Technology; A Constructivist Perspective*. New York: Prentice Hall.
- Kolb, D. (1984). *Experiential Learning: Experience the Source of Learning and Development*. New York: Prentice-Hall.
- Merrill, M. D. (1992). Constructivism and Instructional Design. In T. Duffy & D. H. Jonassen (Eds.) *Constructivism and the Technology of Instruction*, (pp. 99-114). Mahwah, NJ: Lawrence Erlbaum Associates.
- Spiro, R. J., Feltovich, P. J., Jacobson, M. J., and Coulson, R. L. (1991). *Cognitive flexibility, constructivism, and hypertext*. *Educational Technology*, (pp. 24-33). Online: <http://www.ilt.columbia.edu/ilt/papers/Spiro.html>

Villegas, J. (1997). Simulation Supported Industrial Training. In Saunders and Cox (Eds.) *The International Simulation and Gaming Yearbook*, (Vol. 5) London: Kogan Page.

## **BIOGRAPHY**

Timo Lainema has research interests in developing interactive and authentic business games for business education purposes. This research is multidisciplinary and includes such research topics as the impact of time in decision-making, business processes, structured vs. unstructured decision-making, experiential learning, organizational learning and constructivist learning principles. Timo's email address is [timo.lainema@tukkk.fi](mailto:timo.lainema@tukkk.fi).



# **INTERACTIVE 3D VIRTUAL HYDRAULICS**

## *Using virtual reality environments in teaching and research of fluid power systems and components*

L. Pauniahho, M. Hyvönen, R. Erkkilä, J. Vilenius, K. T. Koskinen and M. Vilenius  
*Institute of Hydraulics and Automation, Tampere University of Technology*

**Abstract:** In this paper we show how three-dimensional virtual reality models can be used in teaching the structures and functions of hydraulic components. This technique allowed the teacher to show exactly how a slide moved inside a valve and how it affected on the opening of flow orifices thus increasing or decreasing the flow. Students were taken on a tour inside components to examine the critical points in component behaviour. The use of virtual reality benefits the students in learning hydraulic phenomenon faster and more accurately. In this paper the techniques and use of virtual reality system in teaching and research are presented.

**Key words:** graphics, human computer interface, modelling, research, simulation

## **1. INTRODUCTION**

At the Institute of Hydraulics and Automation (IHA) in Tampere University of technology (TUT) different methods of virtual teaching has been used since autumn 2000, when first internet-based course was held. From using Internet-based technologies the Virtual teaching extended to using virtual reality. The use of 3D interactive virtual reality in teaching fluid power started with Introduction to water hydraulics -course in autumn 2002 after the acquisition of virtual reality system in summer 2002. This course is part of Tampere University of Technology's Virtual University project.

Both the software and the structure of the hardware of the system are presented. It is also shown how the system is used in teaching and in research and design.

## 2. THE VIRTUAL REALITY SYSTEM

The system used is a German made system provided by IC:IDO GmbH. It utilizes so called passive stereo projection system. The projection screen is 1500mm in height and 2000mm in width.

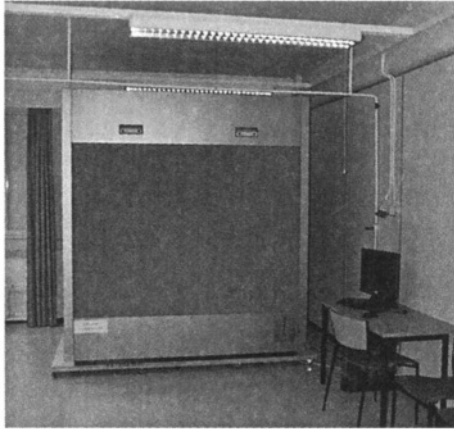

*Figure 1.* The IC:IDO virtual reality system

In this system a three dimensional image is created using two projectors so that two slightly different images are presented simultaneously one over the other. Images are seen separately by both eyes using polarized lenses on the projectors. The lenses filter the images to vertically and horizontally polarized images. The system user then has lightweight polarized glasses which then filters out the right eye image from left eye vision and vice versa. This creates a feeling of only one image that is three dimensional.

### 2.1 System Hardware

The hardware consists of three parts: image projection, interaction and computing. Image projection is done in a closed box to avoid scattered light interference on the images. Two Digital Light Processing™ (DLP™) projectors send images to a mirror which reflects it on the backside of the projection screen. The mirror is used to reduce space needed.

Interaction is made so that both the user and the 3D-control device are position tracked. User is tracked with optical position tracking with two infrared cameras. That gives the benefit of user being able to look at the object from different angles by moving around it just like in reality. Because the image is wall projected the user cannot walk all the way around the

object, but the user can for example look closer or walk back to get more distance to the object presented. The 3D control device used to control the views and functions of the image is magnetically tracked. This gives the device a true 3D handling capabilities with all six degrees of freedom in space. For example a joystick has only two degrees of freedom.

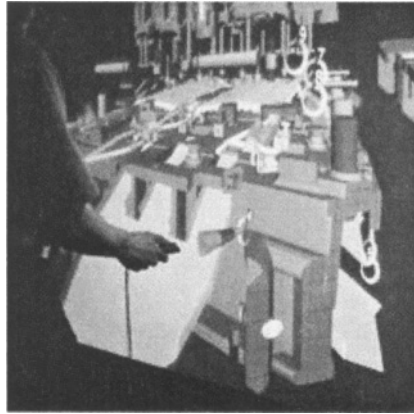

*Figure 2.* 3D control device.

Computing part of the system consists of three Linux PCs, a tracking computer and IC:IDO synchronization module. These are connected with Local Area Network and serial connections. One PC is the controller with session management while others manage image processing tasks.

## **2.2 Stem Software**

Software can be divided into three parts: data and file handling, image handling and connection programs.

The first; IDO:Base interactive, is used in uploading images to the controller computer and there optimizing the images for fluent VR usage. It has, among other things, support for all common interaction components in VRML, VR graphics libraries and multi-channel graphics support.

The second part, IDO:Review, is used with 3D interactive ball-shaped menus and the 3D-control device to handle the images on the screen. User can have mock-up functions (installation/removal), interactive cutting function ( whole object or individual parts and assemblies), measurement function with snap-in function, annotations and screen shot to get still images from a session together with fly-through function and simulation control for kinematics and deformation processes.



The connection programs handle the data flows from magnetic tracking and other devices together with communications between the three computers. The software of this system is of commercial production and therefore it cannot be edited to suit any other learning domain as it is. However it is possible to make some programming to it with high-level commands using separate developer-kit software. With this for example other input devices could be linked to the system, but this is something we have no experience with.

### 2.3 Usability of the System

The images used in this virtual teaching are not images of real industrial made hydraulic components because when an object is as accurate in details as a real component is, its virtual model becomes so large in bytes that handling them with this system becomes disturbingly slow and jerky. The desired goals in teaching are not achieved with this because all students will lose the attention wondering will this VR-system ever work. Instead the images are made from newly designed components where most significant factors are visualization of main component functions and structural features.

To create a virtual object one needs a model in Virtual Reality Modeling Language (VRML) -format. In this case they were done by first drawing the selected components with ProEngineering 3D design program and then converting them in to VRML -format. Use of almost any other 3D design program is also possible.

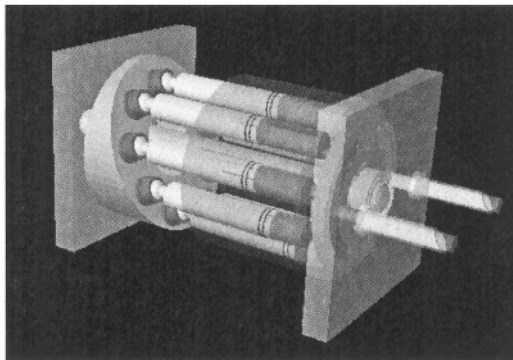

Figure 3. A rough presentation of axial piston motor

The use of ProEngineering program is justifiable because at IHA we had some drawings made with that program already. Also to make the

components accurate enough one needs to design them very carefully and in professional manner so that their main functions and structural features wouldn't differ significantly from actual components used in real hydraulics. Since this system is not using high-power super computers in image handling this kind of image optimizing already in the drawing phase is needed. That is not the best possible usability, but very well in line with the resources needed in establishing this system.

### **3. 3-D VR IN TEACHING OF FLUID POWER SYSTEMS AND COMPONENTS**

#### **3.1 The courses**

The system was used in Introduction to water hydraulics course. The course took place in autumn 2002 and 15 students attended to this course. The course objectives are to give basic information on the theory of water hydraulics, water hydraulic components and systems, and the application of water hydraulic technology in the design of hydraulic machines. Also is the course handles basic theory of water hydraulics, water hydraulic components, design of water hydraulic systems, proportional and servo systems in water hydraulics and applications. At the moment the system is not used in other courses, but it will be presented in other courses as well. The usage is now settled to presenting components and their functions but other ways of using it will be presented later.

#### **3.2 Possibilities in VR visualization**

The problem with many of the hydraulics courses is the difficulty of displaying the structure, motion and functions of hydraulic components so that they are easily understandable for students. Problems occur especially on visualizing altering pressure, fluid flow in orifices, sliding couples or parts moving compared to each other. Using two dimensional pictures is easy for teachers; pictures are quite easily available from partners in hydraulic industry so that they don't have to be drawn from scratch. Also some animations and videos are available, but they are rare and don't show all the components or functions desired. Using those methods students have been able to understand hydraulics – eventually.

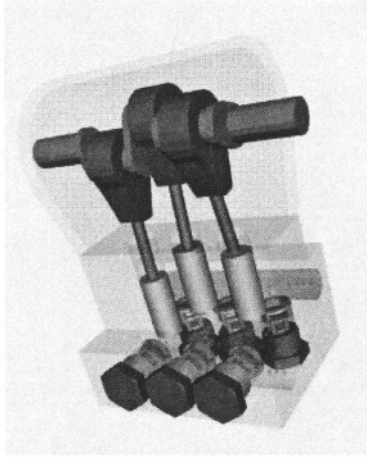

Figure 4. A piston pump 3D animation (still frame)

To be able to give students profound knowledge about hydraulics more quickly and thoroughly, one needs to be able to display hydraulic components like in real life, but with more functionality. It is not enough that they can be seen in three dimensions. They must also be presented interactively in such a way, that students can turn and roll the object and look at whichever detail they want from which ever angle or view. And then the students must be able to disassemble the objects piece by piece to see the assembly structure and to even go inside an object to see its functions in action. Also the component structure must be viewable in slices from various directions.

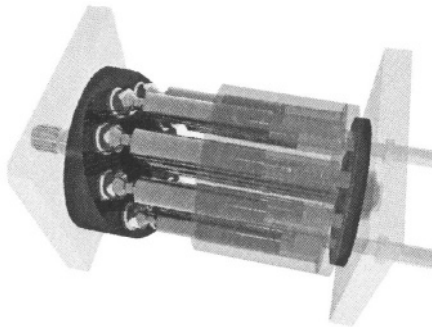

Figure 5. A still frame of an axial piston motor movie

In the course mentioned, so called virtual sessions were held in which a few components were introduced to the students. The number of students to attend to each session was limited to 7-8 students. Having more students in one session could result in reduction in viewing possibilities to some students and again the teaching results could not have been achieved.

Animations were made of selected components for virtual sessions in this course. These were axial piston motor (presented above), needle valve, flow control valve and a piston pump (presented above), ProEngineering files were also made of 15 other components, and they were transferred to VRML-files and presented to students.

### **3.3 Future plans**

The system will be used also in other courses in the future. Generally it will be used in the same way as in this course but other ways of utilizing the system are under construction. For example connecting a real-time simulation to the system would open a new world in teaching modelling and simulation of hydraulic systems.

## **4. USING 3-D VR ENVIRONMENT IN VISUALIZATION OF SIMULATION IN COMPONENT AND SYSTEM DESIGN**

Usually simulation gives out graphs which then are interpreted by researchers. With VR-system visualization of simulation processes improves understanding what actually happened and which circumstances were critical to the results. It also gives the opportunity to see easily that everything in the simulation model is like in real life to give the simulation reasonable basis. Adding 3D presentation to real-time simulation gives the researchers possibilities to go further for example in the field of embedded systems simulation in mobile environments.

To use 3D model of a component while designing with a 3D design program gives benefit to design process, but to be able to see the design in real 3D virtual environment gives the designer more accurate description of the whole picture. The ability to see component sub-parts' movements compared to each other or to see how a component fits into a mobile machine gives so remarkable benefit that many manufacturers are nowadays moving to use virtual environments in their design work.

## 5. CONCLUSIONS

The use of this kind of 3-D interactive virtual reality system in teaching fluid power components has shown its demonstrative power. Even though no official research was made among students, it was obvious that this method of explaining component functions is by far much more educating than the usual 2D drawing method. Also the ability of dismantling the components right there before the students' eyes proved to be very efficient.

Using 3D virtual reality as a way of improving teaching and design processes will be in an important role in the future. One can see an increasing interest in this technology in many industrial sectors. Research and development will probably be the most important fields but also other fields such as marketing and building trade have a vigorous increase in using virtual reality.

## REFERENCES

- Kirchberger, B., & Schleth, A. (2002). Virtual Reality in Product Design of Pneumatic Components, *Proceedings of IFK 2002*, Aachen, Germany, 2002.
- Ilpo Reitmaa et al., *Virtuaaliympäristöt – kuvan sisälle vievät tekniikat*, TEKES 45/95, Helsinki, 1995.

## BIOGRAPHY

The authors of this paper have various backgrounds from programming and simulation modelling to long-term extensive professional experience in hydraulics.

# ACCESSIBILITY AND MOBILE LEARNING

Antti Syvänen, Mikko Ahonen, Anu Jäppinen, Marika Pehkonen, Hanne Turunen and Teija Vainio

*University of Tampere Finland*

**Abstract:** During the Digital Learning and MOBIlearn projects, the authors have acknowledged a new gap in defining accessibility in the context of mobile learning. This document describes this gap and seeks a broader definition of accessibility. Accessibility is discussed in terms of 1) usability, 2) a digital divide and 3) evaluation. First they describe how accessibility is traditionally understood in usability design and what issues mobility brings to accessibility. Secondly, equality issues are discussed in the context of a digital divide. Then the mobile learning evaluation framework is introduced and the implications of accessibility on evaluation are discussed. Finally, these perspectives are integrated and future research topics are proposed.

**Keywords:** mobile learning, equality issues, informal learning

## 1. INTRODUCTION

Accessibility has generally been defined as the ability of all people, regardless of the type or degree of disability, to have access to facilities and services. Another commonly used term is “Barrier Free”, implying that there should not exist any accessibility barriers for anyone. In order to find a reasonable way to use mobile tools in learning process the challenges in their accessibility must be recognised. Mobile learning process differs from a traditional e-learning process especially in an accessibility area. Learning, communication and observation tasks are now taking place outside classrooms and other training facilities, which reveal the vulnerability of accessibility concepts. Are we ready to be always accessible and available? Are current mobile learning services truly accessible in terms of learning and time management needs? Does the use of mobile learning services create

additional costs for the user? Should accessibility considerations also include the evaluation of required mental resources in mobile learning? These kinds of questions have been the daily concern in Digital Learning and MOBIlearn research projects. In order to respond to these questions, an evaluation framework has been developed in Digital Learning project.

## **2. THE RESEARCH PROJECTS**

Digital Learning research project, funded by TEKES (the National Technology Agency in Finland), has been set up in order to investigate and develop new mobile and web-based learning and studying methods, tools, software programs and concepts (Digital Learning 2001). The pilots in Digital Learning have provided valuable input relating to accessibility. The following primary school example is used to describe the accessibility challenges of mobile devices. .

Nokia 9210 Communicators, which are originally designed for business-centric usage were used during the pilot. A teacher made an observation that the boys learned fast to use the interface of the mobile device. To them the device was a cool and entertaining gadget. On the other hand, the girls learned much slower, but their persistence paid off as they found faster the real meaning of using a mobile device in learning. This demonstrates that accessibility has many unpredictable aspects that have not yet been acknowledged properly. These aspects involve attitudes and orientations to new technical devices, which again affect motivation. Consequently, it is crucial to observe long-term use and whether or not a meaningful relationship to the media is formed.

MOBIlearn research project is a worldwide European-led research and development project funded by the EU IST-programme. The project explores new ways to use mobile environments to meet the needs of learners working independently or with others. A new m-learning architecture will support creation, brokerage, delivery and tracking of learning and information contents by using ambient intelligence, location-dependence, personalization, multimedia, instant messaging (text, video) and distributed databases. Field trials cover ‘blended learning’ (as a part of formal courses); ‘adventitious, location-dependent learning’ (during visits to museums); and ‘learning to interpret information sources and advice’ (acquiring medical information for everyday needs). (MOBIlearn 2003).

Our research team in MOBIlearn is responsible for usability and user interface research and design. In the pilot strands especially accessibility in relation to adaptation has proved to be interesting: for example, novice users hardly ever use the tools to adapt the interface. Consequently they are in an

unequal position in using the service compared to experienced users. Adaptability in learning systems should therefore be restricted to a couple of selections or definitions, like learning level (expertise) and instruction language.

### **3. USABILITY IN RELATION TO MOBILE ACCESSIBILITY**

Usability can be seen as accessibility related in many different ways. Shackel (1991) points out that acceptance of an application by the end users can be seen as a primary goal of interactive systems design. In order to meet that goal the issues of utility, usability, likeability and costs should be discussed further.

Mobile devices are challenging from the usability point of view in several ways. First of all, a mobile device has a small display space. Therefore problems arising from the design of information presentation are essential. Secondly, input methods are limited in mobile devices. Thirdly, small devices have limited power. Also the context of a mobile system affects the input method. There are different situations in which people want to be connected to their learning resource. The WWW Consortium develops standards for mobile devices to support multiple interaction modes (<http://www.w3.org/2002/mmi/>). This multi-modularity gives us different interaction modes that can be implemented: speech, vision, pen, gestures and haptic interfaces. Interaction modes could enable communication between people with different devices anywhere and any time.

Usability issues can be approached as issues involving accessibility. In usability engineering the term accessibility is widely referred to as a web-centric phenomenon. The WWW Consortium has built series of accessibility guidelines published by the Web Accessibility Initiative (<http://www.w3.org/WAI/>) giving recommendation on how the Web should be accessible for everyone. The change from traditional e-learning solutions to mobile ones requires careful examination of existing accessibility related issues. In that change of the culture it would be reasonable to use these existing guidelines.

In designing proper mobile learning devices all usability risks should be taken into consideration. Especially in the case of mobile devices and their interfaces all usability factors are crucial. When testing a www-page, the context and environment are of second interest and the traditional design principles presented by Nielsen (1995) apply. But, when testing the usability of a mobile solution, the context is the key element. Lindroth and Nilsson (2001) have argued that it is difficult to test mobile devices with traditional



usability test methods. Designers should be aware that the devices are for real mobile situations. One example of these real situations is a person walking in a rain with the mobile device in hand. On the EU level, accessibility issues have been approached under ‘Design for all’ and eAccessibility initiatives. Accessibility has been defined in terms of people with different needs or different types of disabilities. One of the main objectives is a social inclusion: especially the integration of older people and people with disabilities into the information society. The means to achieve this is to design mainstream products and services to be accessible by as broad a range of users as possible operating within the widest possible range of situations. The idea is to offer means and recommendations to design better usability and accessibility for environments, products and services, and to promote standardisation. Usability aims at easiness of use by emphasizing normal and typical, whereas accessibility considers different uses, which can even be characterized as atypical or abnormal. This means that there are potential conflicts, but usually usability and accessibility considerations largely lead to similar guidelines and solutions. (The Diffuse project 2002).

On the other hand, if the restrictions and barriers to special groups, e.g. the handicapped or the elderly, are taken as problems to be solved in design, the solutions can be useful to everyone. When considering the digital divide, advocating accessibility can also be seen as means to facilitate using the web or mobile services without skills needed for the typical PC use. Here different needs may cause conflicting requirements as well. In mobile learning situations learners may be on a different level, prefer different learning styles or orientations and may need different content and support. Also the contents and presentation of the services have to be adapted according to the device and network characteristics (Kaasinen 2000).

#### **4. ACCESSIBILITY AS A MOBILE LEARNING EVALUATION COMPONENT**

As mobile devices are a pervasive medium they can help to combine work, studying and leisure in a meaningful way (Ahonen, Joyce, Leino & Turunen 2003). Sharples (2000) has pointed out that mobile devices should be seen especially from the perspective of lifelong learning. Likewise, we consider mobile learning as a persistent activity, which requires a long-range use of mobile devices. In Digital Learning project researchers have developed a model for the evaluation of mobile learning. The following “m-learning components”-model especially takes notice on flexible (Collis & Moonen, 2001) and informal learning practices:

- Continuity and adaptability between learning contexts: How to support spontaneous learning?
- Learning as a personal process. Are the mobile learning products taken personally?
- Contextuality in learning: Is the context of learning better recognized in learning process?
- Accessibility: What is the adequate skill level for mobile learning?
- Support for time and learning management. How to support learner's self-monitoring and regulatory processes?
- Flexible interaction. How to enhance communication between peer-learners?

Later the components of m-learning will be operationalised into an on-line self-rating questionnaire adopted for two target groups representing the Finnish comprehensive school students (N=90) and adult learners (N=50) who have real m-learning experiences. The components will be utilized for developing evaluation methods for m-learning materials and environments. They also provide approaches for building m-learning learner profiles, applications and materials. The accessibility is seen here as the kind of competence a mobile learning solution expects from a learner: whether reasonably many can easily achieve meaningful learning with these expectancies. This has important consequences to the user-centered design. Failing to notice this leads to inequality. On the other hand noticing this means also realizing the cultural differences of the user groups.

## **5. UNITING PERSPECTIVES OF ACCESSIBILITY**

We foresee that mobile accessibility issues should be inspected from a wider perspective than often referred in usability literature. The combination of a traditional special group and an equal accessibility point of views offer a new important way to see this matter. In this paper also other ways are suggested to enhance the scope of accessibility.

Research results arising from the CSCW (Computer Supported Co-operative Work) area have interestingly some models that integrate those earlier mentioned, new accessibility elements for mobile use. The following figure from Churchill & Wakeford (2002) indicates needs to consider the distance of information and levels of mobility.

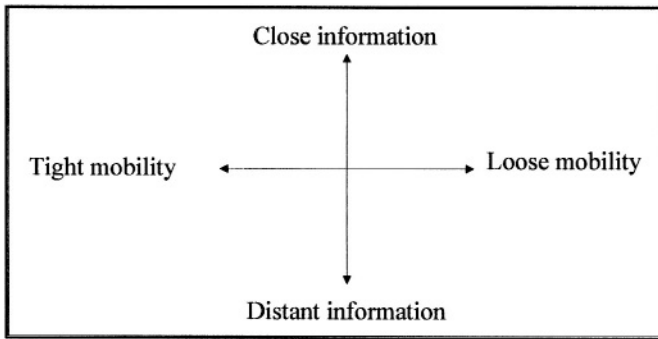

Figure 1. Design dimensions for mobile collaborations

Although mobility is usually associated with movement between geographically situated spaces, and is therefore linked to travel, it must also be thought in terms of time and not simply as expedient goal achievement. Mobile workers do not just need to connect while on the move (in airports, on trains, in cars and at remote locations). Their fundamental experience of mobility is embedded in an experience of temporality, which includes mutually negotiated rhythms of contact, availability and accessibility. (Churchill & Wakeford 2002, 173). The temporality and synchronicity of communication provide new noteworthy challenges for designing accessible mobile learning services.

We argue that the questions stemming from digital divide (Norris 2000) research practices should also be taken into account in designing accessibility for mobile learning. According to Sharples (2000), wider access to learning resources in the worldwide web from public places such as libraries has been seen as an answer for this. Less consideration has been given for providing technology to help people to learn when and wherever they choose and to support personal learning throughout a lifetime.

Drake (1999) mentions that learning must be a life-long process, but it also needs to be seen as a life-wide and life-deep as well in order to fully support the preparation for life. Therefore, to support lifelong learning, learning outcomes should be adaptable to the multitude of life situations. This means noticing people with different needs and different skill levels.

## 6. CONCLUSIONS

Accessibility should be seen as a more multifaceted area of usability and it should be implemented in designing products for mobile educational

purposes. Many old guidelines still apply but some important new ones are as well worth inspecting. This should also be taken into account in evaluation, especially in the case of mobile learning if the devices are seen from the lifelong and life-wide learning perspectives. Having potentially wide impact on everyday life and ways of action, this can in the worst case be a source of inequality and a new item of digital divide discussion.

Future research questions for accessibility in mobile learning could include online and offline synchronization studies in CSCW and CSCL contexts. Also better understanding on the time management is needed from users' personal perspectives. Mobile learning prototype development should advance towards recognizing more comprehensive definition of accessibility. This in turn means supporting all four areas of mobility mentioned by Churchill and Wakeford and better understanding of the personal resources people have to work with.

## REFERENCES

- Ahonen, M., Joyce, B., Leino, M. & Turunen, H. (2003). Mobile Learning - a Different Viewpoint. In H. Kynäslähti & P. Seppälä, (Eds.) *Mobile Learning*. Helsinki: IT-Press.
- Churchill, E. & Wakeford, N. (2002) Framing mobile collaborations and mobile technologies. In B. Brown, N. Green, & R. Harper (Eds.) *Wireless World. Social and Interactional Aspects of the Mobile Age*. London: Springer.
- Collis, B. & Moonen, J. (2001). *Flexible learning in a digital world: experiences and expectations*. London: Kogan Page.
- Digital Learning. (2001). *Project web-pages*. (2001, 20.10.2001). Retrieved 14.02, 2003, from <http://dll.hamk.fi/dl/en/index.html>
- Drake, C. (1999) Values Education and Life-wide Learning. Paper presented at the 16<sup>th</sup> Annual Conference of the Hong Kong Educational Research Association. Retrieved 14.2.2003 from <http://www.livingvalues.net/pdf/lvlearning.pdf>.
- Kaasinen, E. (2000) *Mobile-transparent approach to adapt web services for WAP devices*. Available [http://www9.org/w2-mobileweb/www9\\_workshop\\_kaasinen.html](http://www9.org/w2-mobileweb/www9_workshop_kaasinen.html).
- Lindroth, T. & Nilsson, S. (2001). *Contextual Usability. Rigour meets relevance when usability goes mobile*. Retrieved 14.2.2003 from [http://ecis2001.fov.uni-mb.si/doctoral/Students/ECIS-DC\\_LindrothNilsson.pdf](http://ecis2001.fov.uni-mb.si/doctoral/Students/ECIS-DC_LindrothNilsson.pdf).
- MOBlearn (2003). *Project pages*. Retrieved 14.2.2003 from <http://www.moblearn.org.acce>.
- Nielsen, J. (1995) *Multimedia and hypertext. The internet and beyond*. Boston: AP Professional.
- Norris, P. (2000). *The Digital Divide*. Retrieved 14.2.2003 from <http://ksghome.harvard.edu/~pnorris.shorenstein.ksgh/acrobat/digitalch1.pdf>.
- Shackel, B. (1991). Usability – context, framework, design and evaluation. In B. Shackel & S. Richardson (Eds.). *Human Factors for Informatics Usability*. (pp.21-38). Cambridge: Cambridge University Press,
- Sharples, M. (2000) The Design of Personal Mobile Technologies for Lifelong Learning. *Computers and Education*, 34, 177-193. Retrieved 14.2.2003 from <http://www.eee.bham.ac.uk/sharplem/papers/handler%20comped.pdf>.

- The Diffuse Project, (2001). *Guide to Web Accessibility and Design for All*. (2001, December 2002). Retrieved 14.2.2003 from <http://www.diffuse.org/accessibility.html>
- W3C. (2002). *Multimodal Interaction Activity*. Retrieved 14.2.2003 from <http://www.w3.org/2002/mmi/>.
- W3C. (2002). *Web Accessibility Initiative (WAI)*. Retrieved 14.2.2003 from <http://www.w3.org/WAI/>.

## BIOGRAPHY

Antti Syvänen has research interest in the human emotion, motivation and cognition related to using new communication technologies in learning. His recent research has focused on developing a theoretical model, evaluation methods and meaningful future scenarios for effective mobile learning.

Mikko Ahonen has research interests in learning systems, ubiquitous computing and collaborative learning. His dissertation work focuses on digital portfolios and lifelong learning organisers facilitating human resource development.

Anu Jäppinen has research interest in the user centered design methods, usability and adaptivity in user interfaces of mobile devices and systems. Recent research has focused on how different learners' learning styles or levels of experience can be taken into account when designing mobile learning environments.

Marika Pehkonen has studied digital media use and premises of content production among cultural organizations. Recent research and development has focused on mobile learning, usability, and mobile learning content production.

Hanne Turunen has research interests on new learning technologies such as mobile learning. Recently she has done research work concerning the issues of mobility and new ways to structure knowledge especially among primary school students. The mobile learning in adult education and informal learning situations are also included in her research area.

Teija Vainio has research interest in issues involving human computer interaction. Recent research has focused on usability issues in virtual reality and mobile learning environments.



## **SECTION 6: DESIGN**

# DEVELOPING TIME-SENSITIVE HYPERTEXT LINKING AND NAVIGATION SUPPORT

Anneli Heimbürger

*Tampere University of Technology, Pori, Advanced Multimedia Center (AMC)*

**Abstract:** Hypertext links play an important role in tracking the relationships within and among sets of documents. In our paper we discuss two approaches to creating dynamic workflow charts with time-sensitive linking and navigation support for training time-based project management in distributed Web-based environments. A bottom-up approach is based on the XML Linking Language (XLink) and the top-down approach is based on the XML Topic Maps (XTM) 1.0 specification.

**Key words:** design technology, hypermedia, industry practices, Internet

## 1. INTRODUCTION

Web-based project and document management platforms play an important role in distributed project execution. Particularly when projects involve numerous teams situated in various locations, such platforms provide an effective place and time independent environment for communication, information interchange and monitoring the progress of the project. Before implementing such a system, an organization analyses its information management processes with related teams, project deliverables and document process steps. As a result of the analysis, the organization has defined document classification, uses, user groups, life cycles, states (such as new – in work – for approval – published), structure of project portfolios and finally, a flowchart of the whole process. The organization-specific process flowchart is an essential tool for training project teams, members and managers in organizations. The chart makes it easier for project members to understand their roles and responsibilities in a project. They can see



themselves as parts in a whole workflow. This often helps project teams to adopt a new project management system and new ways of action, adds commitment and minimizes possibly existing resistance to change.

However, mapping training project operations against the project schedule is a problem with a static flowchart. Project management instructors need additional methods and tools to illustrate temporal characteristics of a project and to create time-based views to project repositories. The main object of training time-based project management in enterprises is to decrease project lead-times and bring economical benefits with increased competitiveness.

In our paper we discuss two approaches to create dynamic workflow charts with time-based linking and navigation support. The bottom-up approach is based on the XML Linking Language (XLink) specification, which has a recommendation status in the World Wide Web Consortium (W3C). XLink provides richer and more flexible mechanisms for defining link traversal rules than traditional (X)HTML. The top-down approach is based on the XML Topic Maps (XTM) specification, which is the Web version of the ISO 13250 Topic Maps standard (ISO 13250; XTM TopicMaps.Org 2003).

The remainder of the paper is organized as follows. Related work is reviewed in Section 2. The concept of time-sensitive hypertext linking mechanism is introduced in Section 3. Bottom-up and top-down approaches to create dynamic workflow charts with time-based linking and navigation support are discussed in Section 4. Our conclusions and issues for further research are presented in Section 5.

## **2. RELATED WORK**

Open hypermedia is an area that has been studied by the hypermedia community for several years and for which a number of systems have been implemented (Bieber et al. 1997; Carr et al. 2000; Carr et al. 2001; Grønbaek and Trigg 1999). In open hypermedia systems (OHS), links are managed and stored in special databases called link databases or linkbases. The idea of abstracting links from documents allows for a great deal of flexibility in link maintenance and re-use. The XML Linking Language (XLink) is increasingly moving the Web towards the open hypermedia approach (Heimbürger 2003; W3C 2003c). XLink is also a part of the W3C's Semantic Web –activity (Berners-Lee et al. 2001; van Ossenbruggen et al. 2002; W3C 2003a). The aim of the Semantic Web is to have data on the Web defined and linked in a way that it can be used by machines not just for

display purposes, but for integration and reuse of information across various applications.

Ontologies and ontology representation languages are a popular research topic in various communities such as knowledge engineering, natural language processing, co-operative information systems, intelligent information integration, and knowledge management (Carr et al. 2001; Guarino 1995; RosettaNet 2003; WordNet 2003). Some authors have also dealt with time ontologies (Zhou and Fikes 2002). Applications of the Topic Maps standard include mainly designing Web pages or portals (Park and Hunting 2003; Pepper 2003; Pepper and Garshol 2003). Hameri et al. have investigated distributed project management and its training extensively, both from the general and time-critical point of view (Hameri, and Nihtilä, 1997; Hameri and Nihtilä 1998; Hameri and Heikkilä 2002).

Our study is a complete new effort to describe time-sensitive linking mechanisms, apply it to time-based project management and its training in distributed multi-organizational project environments.

## **2.1 Time-Sensitive Linking Mechanisms**

Time, as an abstract concept, means a space of time points reached from one another by before and after-like operators. Time is a collection of temporal items such as, moments, durations and instants. Things in time are somehow correlated with these temporal items. We call this correlation temporality or temporal rules.

Time points are used to represent specific, instantaneous, points along a time line. Time intervals are a set of constraints between two points, a start and an end time. Relationships between time intervals are defined with Allen's 13 relations: before  $(t_1, t_2)$ , equal  $(t_1, t_2)$ , meets  $(t_1, t_2)$ , overlaps  $(t_1, t_2)$ , during  $(t_1, t_2)$ , starts  $(t_1, t_2)$ , finishes  $(t_1, t_2)$ , and their inverse (Allen 1991).

In time-sensitive Web applications we can identify the following levels: a) content and/or pieces of content are functions of time, b) content and/or pieces of content as well as links between them are functions of time and c) links between content and/or pieces of content are functions of time. Time-sensitivity can include either predictable or non-predictable temporal relationships among content elements included in an application. In a predictable case, temporal rules can be resolved and defined before the application runs. Such an application consists of a single time line with which the different elements are synchronised. It is not affected by the activation of links and as such does not provide for non-predictable changes.

User interactions or other external entities that lead to non-linear proceeding or adaptation according to the user's interest are examples of non-predictable temporal relationships. Non-predictable temporal relations

can be described with time-sensitive link traversals. Allen's interval relations give us a base for describing temporal rules and creating time-sensitive linking mechanisms and navigation support for time-based project workflow charts.

### 3. FROM BOTTOM-UP TO TOP-DOWN APPROACH

We can approach the problem of describing time-sensitive hypertext linking mechanisms in two ways: with the top-down and bottom-up approach. Extensible Markup Language (XML) is the common base for both (W3C 2003b). The top-down approach can be applied to describing both project specific and general temporal rules whereas the bottom-up approach concentrates on describing project specific temporal rules.

There are organizations with only one type of project process but there are also organizations with multiproject processes i.e. managing several projects at the same time. Needs for single and multiproject management skills in organizations have motivated us to research two approaches in developing time-sensitive linking and navigation support for training time-based project management.

The bottom-up approach in our context means (a) to describe temporal rules or link structures such as "if  $t > t_1$  then link to **doc**<sub>1</sub> or "if  $t_1 < t < t_2$  then link to **docgroup**<sub>1,2</sub> according to Allen's interval relations and (b) to formalize temporal linking rules by means of expanding the multiple linking mechanism defined by the XLink specification with time attributes. In practice this means constructing links to project documents from different blocks and connectors of blocks of the project flowchart according to temporal rules, which describe the progress of the project, states of related documents and their time status transitions.

When the user activates a certain block in the flowchart he/she can give appropriate time-conditions to retrieve related documents or he/she can navigate in a flowchart according to different temporal views. A specific search command can for instance be, "give me all documents that must have for approval –status within one week" or "give me all documents that I am responsible for and that must have for approval –status within one week".

The bottom-up approach concentrates on constructing time-sensitive linking rules on the content base level. The approach is dependent on resources involved in a certain project and thus is very project-specific. If the organization needs tools for training time-based multiproject management, a set of common temporal rules between different projects as

well as project specific rules can be identified. This motivated us to research an approach, which includes both aspects.

The top-down approach gives a possibility to describe temporal rules common to all projects and hence the time-analysis needs to be carried out only once, nor in connection with every project. XML Topics Maps (XTM) 1.0 specification provides syntax for describing resource independent topic maps. With topic maps an associative information structure, which is located outside that information can be created.

A topic map usually contains several overlapping levels, which are semantically cross-linked. The core of the XML Topic Maps (XTM) 1.0 specification is formed of topics, which represent the subjects the topic map is about. Topics (T) can be grouped in classes called topic types. A topic type is a category to which one given topic instance belongs. A topic may be linked to one or more information resources that are relevant to the topic in some way. Such resources are called occurrences (O) of the topic. Occurrences are information resources relevant to a topic. Topics can be related through some association (A) expressing given semantics. Just as topic and occurrences can be grouped according to type so can also associations between topics be grouped according to their type. Each topic that participates in an association plays a role in that association called the association role. It is important to note that topic associations are completely independent of whatever information resources may or may not exist or be considered as occurrences of those topics. The same topic map can be overlaid on different pools of information to provide different views to users at different points of time or during different time intervals (Figure 1). In our case pools of information are project repositories.

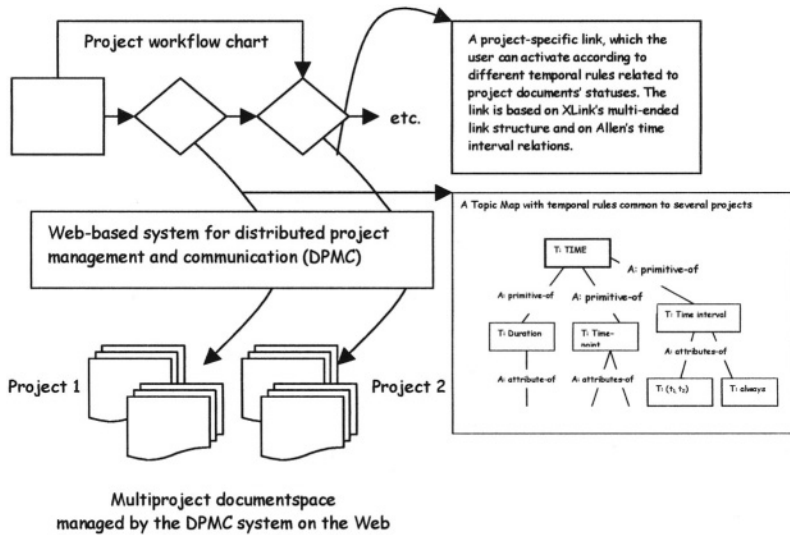

Figure 1. A project workflow chart with single and multiproject specific temporal hypertext linking and navigation support in distributed Web-based project management environment.

Our demonstration will be based on the Kronodoc environment (Kronodoc 2003) and on the flowchart presentation of the organization's information processes. The flowchart can be for instance a PowerPoint file and the links from the blocks or connectors of the blocks of the flowchart point to documents managed by the Kronodoc system. The construction of our demonstration will proceed in two phases.

1. we will add multiple temporal linking mechanisms to flowchart blocks.
2. We will investigate integrating an off-the-shelf Topic Map product such as Ontopia's Topic Map Engine or the K42 by Empolis to the flowchart (Empolis 2003; Ontopia 2003).

Already the first phase gives project management instructors new tools to illustrate and train time-based project management in organizations.

#### 4. CONCLUSIONS AND ISSUES FOR FURTHER RESEARCH

In our paper we have proposed two approaches, a bottom-up approach based on the XLink language and a top-down approach based on the XTM specification, to develop dynamic workflow charts with time-sensitive linking and navigation support related to distributed project management and

its training in organizations. We have presented our framework for demonstration. Although our paper has concentrated on developing tools for training time-based project management, the proposed approaches can be applied to other educational materials where flowchart presentations and time lines are essential such as in teaching history and natural sciences.

An interesting issue for further research is an ontology-driven topic maps approach. With this approach, the ontology is an explicit artifact distinct from the topic map it generates. One advantage of an ontology-driven topic map is its maintainability. When we create the ontology first from which the topic map will be generated we can separate the ontology design from the XTM implementation details. The ontology-driven topic maps approach makes it also possible to use existing ontologies instead of significant investment for creating topic maps from the very beginning.

## REFERENCES

- Allen, J. F. (1991). Time and time again: The many ways to represent time. *International Journal of Intelligent Systems*, 6(4), 341–355.
- Berners-Lee, T., Hendler, J. & Lassila, O. (2001). The Semantic Web. *Scientific American*, 284(5), 28–37.
- Bieber, M., Vitali, F., Ashman, H., Balasubramanian, V. & Oinas-Kukkonen, H. (1997). Fourth generation hypermedia: some missing links for the World Wide Web. *International Journal of Human-Computer Studies*, 47(1), 31-65.
- Carr, L., Bechhofer, S. Goble, C. & Hall, W. (2001). Conceptual linking: Ontology-based open hypermedia. In V. Shen, N. Saito, M. Lyu, & M. Zurko (Eds.), *Proceedings of the Tenth International Conference on World Wide Web*. (pp. 334 – 342). New York: ACM
- Carr, L., Hall, W. & DeRoure, D. (2000). The evolution of hypertext link services. *ACM Computing Surveys*. 31(4), 1–6.
- Empolis. (2003). *Empolis Home Page* (accessed 24.1.2003). <http://www.empolis.co.uk>.
- Grønbaek, K. & Trigg, R. H. (1999). *From Web to workplace: Designing open hypermedia systems*. Boston: MIT Press.
- Guarino, N. (1995). Formal ontology, conceptual analysis and knowledge representation. *International Journal of Human and Computer Studies*, 43(5/6), 625 - 640.
- Hameri, A. P. & Heikkilä, J. (2002). Improving efficiency: Time-critical interfacing of project tasks. *International Journal of Project Management*. 20(2), 143–153.
- Hameri, A. P. & Nihtilä, J. (1997). Distributed new product development project based on Internet and World-Wide Web: A case study. *The Journal of Product Innovation Management*. 14(2) 77–87.
- Hameri, A. P. & Nihtilä, J. (1998). Data-based learning in product development. *Scandinavian Journal of Management*. 14(3), 223-238.
- Heimbürger, A. (2003). Modelling time-sensitive linking mechanisms. In H. Jaakkola, H. Kangassalo, E., Kawaguchi, & B. Thalheim (Eds.). *Frontiers in Artificial Intelligence and Applications, Vol. 94: Information Modelling and Knowledge Bases XIV*. (pp. 26-42). Amsterdam: IOS Press.

- ISO 13250. (2000). *Information technology – SGML applications – Topic Maps*. Geneva: International Organization for Standardization.
- Kronodoc (2003). *Kronodoc Home Page* (accessed 11.2.2003) <http://www.kronodoc.com>.
- Ontopia (2003). *Ontopia Home Page* (accessed 24.1.2003) <http://www.ontopia.com>.
- Park, J. & Hunting, S. (eds.) (2003). *XML Topic Maps. Creating and using Topic Maps for the Web*. Boston: Addison-Wesley.
- Pepper, S. (2003). *The TAO of Topic Maps. Finding the way in the age of infoglut*. (accessed 18.1.2003) <http://www.ontopia.net/topicmaps/materials/tao.html/>.
- Pepper, S. & Garshol, L. M. (2003). *The XML Papers. Lessons on applying Topic Maps*. (accessed 24.1.2003) <http://www.ontopia.net/topicmaps/materials/xmlconf.html/>.
- RosettaNet (2003). *RosettaNet Home Page* (accessed 23.1.2003) <http://www.rosettanet.org/>.
- van Ossenbruggen, J., Hardman, L. & Rutledge, L. (2002). Hypermedia and the Semantic Web: A research agenda. *Journal of Digital Information*, 3(1) [online], (accessed 27.1.2003) <http://jodi.ecs.soton.ac.uk/Articles/v03/i01/VanOssenbruggen/>.
- W3C (2003a). *The World Wide Web Consortium: Semantic Web Activity*, (accessed 23.1.2003) <http://www.w3.org/2001/sw/>.
- W3C (2003b). *The World Wide Web Consortium: Extensible Markup Language (XML)*, (accessed 14.5.2003) <http://www.w3.org/XML/>.
- W3C (2003c). *The World Wide Web Consortium: XML Linking Language (XLink) Version 1.0 W3C Recommendation 27 June 2001*, (accessed 23.1.2003) <http://www.w3.org/TR/xlink/>.
- WordNet (2003). *WordNet Home Page* (accessed 23.1.2003) <http://www.cogsci.princeton.edu/~wn/>
- XTM TopicMaps.Org. (2003). *XML Topic Maps (XTM) 1.0. TopicMaps.Org Specification*. (accessed 18.1.2003) <http://www.topicmaps.org/xtm/1.0/>
- Zhou, Q. & Fikes, R. (2002). *A reusable time ontology* (accessed 18.1.2003) [http://www.ksl.stanford.edu/KSL\\_Abstracts/KSL-00-01.html/](http://www.ksl.stanford.edu/KSL_Abstracts/KSL-00-01.html/)

## BIOGRAPHY

Anneli Heimbürger is working as a senior research scientist at the Tampere University of Technology, Pori. Her research interests are in hypertext link management and XLink-language on the World Wide Web environment. Recent research has focused on developing time-sensitive linking and navigation tools and their applications. Her email address is [anneli.heimburger@tut.fi](mailto:anneli.heimburger@tut.fi).

# VIRTUAL LEARNING MODULES FOR TRAINEES

Heike Köppe

*Höxter Business Schools, Germany. [mail@heike-koeppe.de](mailto:mail@heike-koeppe.de)*

**Abstract:** Even technically inexperienced teachers can create some of their own virtual training units with this most practical tool for everyday teaching use. Previous e-learning solutions have not as yet been able to meet the demand for self-developed tasks that suit the requirements of a particular learning group and this was the reason for this project coming into being. The tasks, as in the later final examination, are based on a number of pre-defined types such as multiple-choice tests, true/false and gap texts. The tool is suitable not only for individual exam practice by the student but also for doing automatically evaluated tests in the lesson situation. The tasks are available either on CD or in the Internet as required. Since its conception this learning system has met with a high degree of approval among teaching staff by way of its ease of application. After regular use in foreign language teaching a significant improvement in student performance has been noted.

**Keywords:** vocational education, authoring systems, tools, learner centred learning

## 1. MOTIVATION

E-learning was intended to be introduced at the BKH Business School in Höxter within the Qualifying and Vocational Training Network Framework of the QBN. In which phases of lessons can such learning software be employed with the greatest efficiency? There are probably numerous examples of software-supported treatments of certain lesson topics for self-study, including the basics of a given subject. But what we (the QBN-team) are basically considering here is enhancing class teaching with additional learning materials. The target groups are students in sometimes extremely heterogeneous groups that have to be introduced to this new learning method slowly for pedagogical reasons.



An analysis of teaching processes in the situation here given (cf. Dick, 2000) shows that one would not be inclined to employ an e-learning system either for the introduction, or for general work, on most lesson topics. On the other hand, it can be helpful in marking and evaluation. We would expect that e-Learning would account for at most 25% of lesson times. Recent research by Breuer (2002; 2003) would imply that up to 40% of the learning process could be covered by an e-Learning system. One of the key areas here would be in the Breuer's third phase, i.e. in the more detailed treatment of lesson topics that the students are, in principle, already converse with, and the learning group as a whole should be accustomed to this way of learning. Breuer would also expect a lesson share of around 25% in the *implementary* phase of an e-Learning system. However, not only the learning group, but also the teacher, must first become accustomed to such a system.

In order to achieve as high a degree of acceptance as possible among staff, we use a system at a point where it can best be integrated into the standard teaching culture. This was a determining factor with regard to its contents. The learning system should be such as to prepare the students for examinations regardless of time or place considerations, and to be able to 'fill in' any gaps in their knowledge. It should also be of assistance to students in addressing typical learning difficulties. Also, the teacher's workload should be reduced in these lessons.

One important requirement of a learning program for use in school lessons is that it is in harmony with the teacher's own teaching concepts, practises and beliefs. It should be able to meet the needs of each of the students, their age, the academic level of the class, as well as any learning difficulties, but at the same time correspond to the teaching style and the choice of material made by the teacher. A purely subject-matter oriented approach would not be flexible enough. The teaching process is designed flexibly so as to meet the needs of each learning group with the same teacher based on the same subject matter.

A learning program that exactly meets the needs of each pupil, their learning difficulties, the teaching style, the teacher's choice of topics and the age of the pupils does not exist. For example, a mathematics program from the well-known Klett Publishing Co. in Germany introduces differential calculus with the acceleration problem of a ball on a sloping surface. Such an approach would be of little sense in a business-oriented college. Foreign language programs at advanced levels, in particular, do not presuppose a level of previous knowledge that suits a given learning group and programs for language beginners are mostly too child-like.

In evaluating a wide variety of commercial learning software we could not find a CMS/LMS system, that was on the one hand sufficiently simple to work with, so as to be acceptable even to sceptical and technically

inexperienced staff, and on the other hand be flexible enough to fulfil the pedagogical requirements, for example, by providing learning aids for typical learning difficulties. This is why we developed our own learning system.

In the following section I will describe the demands with regard to content placed on the system and its technical implementation, the results, evaluation and future possibilities of application and development.

## 2. IMPLEMENTATION

### 2.1 Contents concept

The contents of the e-learning system were based on the commercial clerks examination for business vocations (Kaufmannsgehilfenprüfung für kauf-männische Ausbildungsberufe). This meant that it was directly related to didactical considerations at the Höxter Business College. The direct relation to practical needs and its usefulness in day-to-day teaching, both for the students for the teachers, were key factors in making this decision.

The system should be capable of being employed in two ways: firstly as a training system, and then also as a test system. Key features of the training tasks are tips, explanations, feedback, hot words and learning aids. In the test system the student receives no responses when doing the work, on the contrary the teacher receives a performance overview after the test and can thus quickly and easily ascertain the level of knowledge of the class. (Fig. 1)

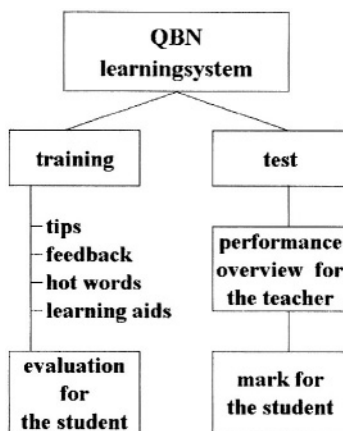

Figure 1. Structure of the system

The types of tasks were developed on the basis of ‘multiple choice - 1 of n’, ‘true/false’ and ‘gap text’ tests. The necessary task structure was developed together with a group of teachers of various subjects. The form of the multiple-choice tasks was developed in line with the later official final examination. Feedback was provided as a learning aid to each possible incorrect answer. In addition, the student can also call up one or two further learning tips and a sample answer (Fig. 2). Another variation is especially suitable for teaching foreign languages.

The evaluation of the performance level is done automatically. The evaluation system was developed by several teachers on a practical basis and it can subsequently be adapted to changing needs. Better assessment of one’s own performance and learning aids that can be controlled individually in the course of working with them all motivate the students towards training with a definite aim in mind.

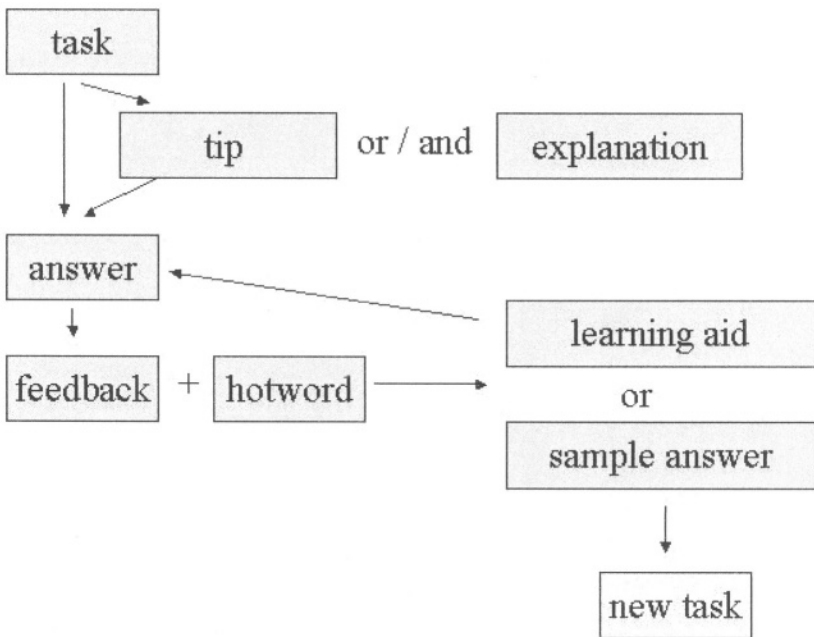

Figure 2. Logical structure of an exercise for training

Fully functional Excel tables that demand student creativity can also be integrated into the mathematics/economics tasks. The pedagogical value of

this type of task is considerably enhanced since the student is given the chance and the stimulus to experiment with any number of variants. (Fig. 3)

**Compound interest 1**  
You have 13500 € and you get 4,25 % interest on it. How much do you have after 5 years?

1 16368,75 €  
2 15342,59 €  
3 16623,18 €

	A	B	C	D
1			rate of interest	4,25
3	Year	opening capital	interest	capital at the end of the year
4	1	13.500,00 €	=B4*\$D\$1/100	
5	2			
6	3			
7	4			
8	5			
9				
10	Compound interest 1			

Please double click onto the table with your left mouse button. Then the table is active.

exercise > EXCEL exit

Figure 3. Added Excel sheet

## 2.2 Technical concepts

We used an authoring system in preference to individual programming in creating the learning software. An authoring system is simpler to operate whilst still being capable of allowing for individual wishes. Because of its versatility and its widespread use in school and industry we chose the Toolbook authoring system. In order to facilitate the exchange of tasks and exercises among staff by way of a uniform structure, and to overcome obstacles in its application, we created an easy-to-use editor for those with little computer experience, with which teachers can produce and organise exercises and help texts. Entry masks are adapted to suit the various types of exercises. Enter errors are automatically detected by special routines.

Exercise/task texts that have been produced can be used both for a test system as well as for a training system. This means that a large number of staff can concentrate on the pedagogical aspects of the job in hand, while a comparatively small team deals with programming itself. The editor was developed so as to enable all staff to work with the free Runtime version of Toolbook. The general availability and easy operation of the editor and the templates also mean that it is possible to produce exercises directly in lessons. The pupils can use the tools to produce their own exercises. This

means, for example, that the pupils can produce exercises based on their mistakes instead of just doing corrections for their tests. In order to be able to provide suitable learning aids and tips on typical learning difficulties, they have to think the theme over much more carefully than was previously the case.

Solution		Type of task: <input type="checkbox"/> S <input type="checkbox"/> G <input checked="" type="checkbox"/> F <input type="checkbox"/> F	insert	copy	clear	delete	reset	⏪	<	>	⏩	Page 1
Header												
Task												
Explanation												
Hint												
Answ. 1												
Answ. 2												
Answ. 3												
Answ. 4												
FB 1												
FB 2												
FB 3												
FB 4												
HW 1.1												

Figure 4. Editor segment, mask for a foreign language exercise

Teachers’ and pupils’ wishes were better able to be put into practise in a number of follow-up versions of the e-learning system due to the close interplay between programming and evaluation in the application phase.

### 3. THE ROAD MAP

With regard to its use in schools, we tried to considerably extend the current number of users – at present around 25, i.e. about half of the staff. Exchanging exercises between staff members is still encouraged, as is the already well-advanced collection of a large reserve of exercises. As of today there are more than 1000 exercises based on various templates that currently find use in lessons in the final year groups in the part-time ‘dual system’ vocational courses and in all full-time classes, with a total of more than 400 students. Training in foreign language courses and performance tests are the

preferred applications at the moment. Selected training units for preparing for all external Chamber of Commerce final examinations are available.

In the long term, practice phases can be given as homework exercises. Subject matter can be didactically prepared so that students may work on certain topics independently. This is the aim of the project 'Fachschule (College) Online'. In everyday teaching, this would enable us to integrate e-learning into the 'introduction to the problem' and 'solution-finding' phases.

With the proposed technical system development, it will be possible to automatically integrate text based content matter, pictures, videos, Excel tables and PowerPoint animations into the template. The enhancement of the test system '1 of n' to an 'x of n' type is soon to be completed – a test system with automatic evaluation.

#### 4. RESULTS AND CONCLUSION

The e-learning project was successfully carried out at the BKH Business School, resulting in easy to use learning software. This software has proven itself in everyday use, and is employed in training and in performance tests. CBT was used for homework exercises in the weaker of two industrial clerk course groups (cf. Gregor, 2003). Students were thus more motivated and took a more active part in lessons as a result of their feeling more versed in the subject matter. Examination results showed that the weaker class had almost made up for the previously existent difference in performance.

#### REFERENCES

- Breuer, J. (2002). Makrodidaktisches Design einer telekommunikationsunterstützten Weiterbildungsmaßnahme: Kombination von Präsenz- und Telelernphasen. In: F. H. Esser, M. Twardy, & K. Wilbers (Eds.), *e-Learning in der Berufsbildung*. (pp. 215-221) Köln,.
- Breuer, J. (2003). Blended Learning? Der Mix von Präsenz- und E-Learning-Phasen unter besonderer Berücksichtigung des Kommunikationsverhaltens der Dozenten in einer E-Learning-Maßnahme. In: F. H. Esser & M. Twardy, M.(Eds.), *Abschlussveröffentlichung zum Modellversuch* (pp.5) Köln: MERCUR
- Dick, E. (2000). *Multimediale Lernprogramme und telematische Lernarrangements, Einführung in die Didaktische Gestaltung*, Bildung und Wissen.
- Gregor, M. (2003). *M.A. thesis*, unpublished, Höxter Business College.

**BIOGRAPHY**

Heike Köppe, born 1963, studied Mathematics, French and Education Studies in Bielefeld and Neuchâtel. She has been teaching at the BKH (Höxter Business College) for 8 years. She took over the project management and the programming for the virtual learning modules.

# A NEW SPIDER ON THE WEB

## *Modelling the Adoption of Web-based Training*

Arthur Tatnall<sup>1</sup> and Bill Davey<sup>2</sup>

<sup>1</sup> *Victoria Graduate School of Business, Victoria University, Australia,* <sup>2</sup> *School of Information Technology, RMIT University, Australia*

**Abstract:** The introduction of a new e-training technology is all very well, but the important question is: will it be successfully adopted and used? Conventional approaches to innovation suggest that adoption decisions are related mostly to the characteristics of the technology, but we will argue that the process is much more complex than this and that these approaches are too simplistic. In this paper we propose an ecological model of technological innovation, and show how it can be applied to considerations of the adoption of e-training products and methods.

**Key words:** Industry training, innovation, technology adoption, ecological model.

## 1. INTRODUCTION

Just because a new product, technique or technology becomes available in education does not mean that educators, trainers or students will adopt and use it. Even if its developer can show that this innovation will greatly improve the learning process, there is still no guarantee that it will be used, as many curriculum designers and educational technologists have discovered.

Rogers' (1995) Innovation Diffusion Theory suggests that the acceptance of a new product or process is mostly due to the characteristics of this product or process. In Nature, releasing 1000 baby spiders—all the same product—will result in only a few successes as the complex environment interacts with each potential spider. In this paper we will show that the application of an ecological model leads to a richer understanding of how the



process of innovation applies to the introduction of new electronic technologies in education and training.

## **2. INNOVATION AND E-TRAINING**

The process of innovation involves getting new ideas accepted and new technologies adopted and used. Introducing new methods of e-training into an organisation is an example of innovation, and the factors that support and inhibit the adoption of these new methods should be identified. Our research shows that acceptance of an innovation is affected more by the complexity of interactions between the people within an organisation than any supposedly objective characteristics of the innovation itself (Tatnall, 2002; Tatnall & Davey 2002a, 2002b). We argue that to accommodate these complexities, and to provide a useful socio-technical perspective, an 'ecological' model (Tatnall et al., 2002b) dealing with the interactions of human and non-human actors within the 'ecosystem' of the organisation provides an effective approach to understanding innovation.

Rogers' (1995) suggests that there are four main elements to adoption: the characteristics of the innovation itself, the nature of the communication channels, the passage of time, and the social system through which the innovation diffuses (Tatnall, 2002). He argues that the attributes and characteristics of the innovation itself are particularly important in determining the manner of its diffusion and the rate of its adoption, and outlines five characteristics of an innovation that affect its diffusion: relative advantage, compatibility, complexity, trialability and observability. We argue, however, that this approach is too simplistic and that a better model would put more emphasis on the people involved.

Borrowing ideas from innovation translation in actor-network theory (Latour 1986, 1996, 1999; Law 1991) we will argue, rather, that it is interactions between people and technology that are all important, as potential adopters may either accept an innovation in its present form, modify it to a form where it becomes acceptable, or reject it completely. An innovation translation approach has been shown to be useful in considering ICT innovation in small business (Tatnall & Davey, 2002b) and in education (Busch 1997; Bigum 1998; Tatnall 2000; Tatnall & Davey 2001).

Recent research has illustrated some of the complex processes people go through in deciding whether or not to adopt an educational technology (Naidu, Cunnington & Jasen 2002). In this paper we incorporate some of the concepts of innovation translation into an ecological framework in which we will consider how adoption of e-training might occur in organisations. This

socio-technical approach enables identification of factors that do not emerge from traditional approaches to innovation.

### **3. AN ECOLOGICAL MODEL OF INNOVATION**

Ecology is concerned with interrelationships between living things and between living things and their environment. It has two key underpinning biological principles: organisms behave in ways that optimise the balance between their energy expenditure and the satisfaction they obtain, and organisms operate within a competitive environment that ensures only the most efficient of them will survive (Townsend, Harper and Begon 2000). These principles can be directly applied to an e-training implementation; when examining the potential for a new e-training method it can be useful to measure the effort required in its implementation, and the satisfaction likely to accrue from its use.

We must digress here to give a word of caution on the limitations and appropriate uses of models and metaphors. A model is not itself reality, but just a representation intended to fulfil some explanatory purpose; models thus always have limitations. A metaphor is a term 'applied to something to which it is not literally applicable, in order to suggest a resemblance' (Macquarie Library, 1981). Models and metaphors are useful only in viewing certain aspects of a complex system. Lovelock, deviser of the Gaia hypothesis, remarked that: 'You've got to use metaphor to explain science, it's part of the process of giving people a feel for the subject.' (Bond 2000)

Ville (1962) defines an ecosystem as 'a natural unit of living and non-living parts that interact to produce a stable system in which the exchange of materials between the living and non-living parts follows a circular path'. Habitat, ecological niches, and the exploitation of resources are all important considerations in ecology (Case, 2000; Krebs, 2001). An ecosystem is a complex entity due to the large number of living things inhabiting it, and to the variety of possible interactions between them (Tatnall et al., 2002a). The 'ecosystem' represented by the introduction of a new e-training technology or approach in an organisation contains the following 'species': e-trainers, e-training developers, software companies, company staff (students), managers and company administrators. The 'environment' can be considered to contain many inanimate objects relevant to the training, including: Tablet computers, Pocket PCs, software applications, textbooks, networks, programming manuals and so on.

In an ecosystem many different individuals and species typically occupy a similar space and can be considered to interact in several ways:

- Competition occurs when two individuals or species each strive for the same thing. When considering the introduction of a new e-training method and whether it will be able to compete successfully, it is useful first to examine the environment for any competing organisms.
- Cooperation is the situation in which each population benefits from the presence of the other, but can survive in its absence. We should examine the environment to see whether there are people, technologies and other elements that will cooperate with a new e-training method.
- Filling a niche, often by occupying an unfavourable location, is a technique used by some species to avoid competition. When considering a new e-training method we can look to see if a boundary exists around the situation intended for the method that will create a niche.

#### **4. TWO SITUATIONS INVOLVING E-TRAINING**

To make discussion of this new model real, let us talk in terms of two concrete examples of innovation and, by applying the model, attempt to show the advantages of our suggested approach.

Consider first an example of mobile e-training in a factory situation. A factory equips each employee with a Tablet PC fitted with wireless networking (probably IEEE 802.11b or something similar). This contains delivery software and a profiling program for the particular employee. As this employee moves through the factory, different machines will be used. For each machine the operating procedures and safety considerations are built into the machine and are made available through wireless networking. Software on the machine recognises the Tablet PC of a new operator and downloads content to the Tablet. The employee then has delivered the training package resident in the machine they are close to. The Tablet PC configures this to the learnt learning style of the employee. Is adoption of this innovation likely and if so, how might we best implement the system?

Secondly we will consider another example of mobile e-training and information provision, this time related to a firm of insurance loss assessors who specialise in industrial claims. Each loss assessor spends some time in the office assessing claims, but much of their time on the road, or examining damage at the premises of insurance clients. Each assessor is equipped with a Pocket PC (something like a Compaq iPAQ) and a mobile phone, each equipped with Bluetooth technology. The mobile phone also has a WAP (Wireless Application Protocol) interface using GPRS (General Packet Radio Service) technology. When the assessor is away from the office at a damage site the mobile phone can be used to contact the office intranet and to download relevant information about the job. The assessor is also able to

download e-training materials relating to the particular insurance company concerned and the nature of the industry involved in the claim. Will an assessor make use of the training materials if they are delivered in this way, or wait until returning to the office to look at the printed manuals?

## **5. APPLICATION OF THE ECOLOGICAL MODEL**

As previously noted, innovation is a complex process and to attempt a simple explanation is worthless. In the examples that follow we are forced, to some extent however, to simplify our explanations in order to fit the constraints of this paper. We trust that the reader will note this fact and make due allowances for the complexity of the real situation.

We will begin our consideration of each of the examples given in the earlier section by considering, in each case, whether any of the following ecological factors has any relevance:

- The environment in which the e-training innovation occurs.
- The energy expenditure in implementing and using the new e-training technology.
- Sources of competition for this new technology.
- Likely cooperative technologies and entities.
- Whether the new technology can find a suitable niche in which to thrive, free from competition.

In the factory situation the ecological model can be applied by considering factors in the environment that are likely to assist adoption and those that may inhibit adoption. The factory environment consists of a large, brightly lit open space, filled with various machines and the workers who operate them. Two environmental factors that may act to inhibit adoption are machine noise and the potential distraction of what is going on around the worker elsewhere in the factory. With the loss assessor out on the road, the environment is, probably, the assessor's car, Pocket PC and mobile phone. Parking well off the major road should lead to few distractions.

Energy expenditure can be examined in relation to the costs in setting up the new e-training system, and the difficulty or bother of using it. These can be measured against the perceived benefits obtained. In the factory, each machine needs to have identifying data, operating information, relevant software, and a radio networking interface installed. Each worker needs to be equipped with a Tablet PC. Each worker must also be taught how to operate this PC. The factory managers must decide whether the costs in setting up and using this system are lower than the benefits in improved productivity and a reduced number of work-related accidents. For the company of loss assessors the set-up costs would be lower – a Pocket PC

and mobile phone for each assessor and some additional hardware and software on the company intranet to allow them to access it. The manager will also need to decide whether the benefits obtained from this system are greater than the energy expended on setting it up.

Competition can come from many sources including other people within and outside the organisation, distractions, other technologies and old ways of doing things. In the factory, machine noise and other things going on around a worker may prove sufficient distraction to cause enough competition to the e-training to make it unproductive. If the worker needs to find out about a machine, but has the option of looking up a paper manual rather than using the e-training materials, this may also prove great enough competition to cause the e-training to fail. Out on the road the loss assessor does not have the option of looking up a paper manual, unless it was taken along when leaving the office, as might occur if it was decided that the e-training materials required too much energy expenditure to use.

A new training officer who is more attuned to e-training could be seen as an entity that would cooperate with this technology. A changed work situation may also act to facilitate cooperation. (It could also have the opposite effect.) In either example it is important to look for other people or technologies that may cooperate with the new technology as these can become staunch allies in the implementation.

In most situations it is probably desirable that the new e-training technology is used throughout the organisation, but in some instances it will find a niche where it is free from unwanted competition. It might be that only certain new machines in one section of the factory are equipped with this technology, or that only some types of operation are related to e-training. With the loss assessors it might be that this technology is only used by some assessors working with particular industrial clients and not used generally.

The point is that for each particular situation in which we were trying to determine the likelihood of a new e-training technology being adopted and used successfully, an ecological model would require the identification of a number of factors. These would include the nature of the environment, all entities and factors within the environment that might compete with or cooperate with the new technology, the amount of energy that needed to be expended in implementing it, and whether it should be implemented in whole or only in part.

## 6. CONCLUSION

In any field it is necessary to use language in framing research questions and in offering explanations. The discipline of ecology offers useful metaphors to accommodate complexity, and so the use of an ecological model can provide useful insights into whether or not an e-training innovation is likely to be adopted.

The main advantages of using an ecological model to consider whether or not a new e-training approach is likely to succeed in an organisation relates to a presumption of complexity and interaction. We are not, for one moment, suggesting that e-training *is* a biological system. What we are suggesting is that concepts of complexity and interaction in this field can be usefully applied to a more incisive consideration of an e-training implementation.

We also argue that use of such a model offers an opportunity to improve the chances of successfully innovation. It can do this through the ways that the new e-training method might improve the balance between energy expenditure and satisfaction obtained, or succeed through cooperation, successful competition or filling a niche. If a manager wants to increase the likelihood that a web-based training innovation will be adopted we suggest using the ecological model and examining the likely consequences. If these factors are taken into consideration while implementing the changes, the chance of successful adoption will be enhanced.

## REFERENCES

- Bigum, C. (1998). Solutions in Search of Educational Problems: Speaking for Computers in Schools. *Educational Policy*. 12(5), 586-596.
- Bond, M. (2000). Father Earth. *New Scientist*. 167, 44-47.
- Busch, K. V. (1997). *Applying Actor Network Theory to Curricula Change in Medical Schools: Policy Strategies for Initiating and Sustaining Change*. Paper presented at the Midwest Research-to-Practice Conference in Adult, Continuing and Community Education Conference, Michigan State University.
- Case, T. J. (2000). *An Illustrated Guide to Theoretical Ecology*. New York, Oxford University Press.
- Krebs, C. J. (2001). *Ecology - The Experimental Analysis of Distribution and Abundance*. San Francisco, Benjamin Cummings.
- Latour, B. (1986). The Powers of Association. In J. Law. (Ed.), *Power, Action and Belief. A new sociology of knowledge? Sociological Review monograph 32* (pp. 264-280.) London, Routledge & Kegan Paul.
- Latour, B. (1996). *Aramis or the Love of Technology*. Cambridge, Harvard University Press.
- Latour, B. (1999). On Recalling ANT. In J. Law & J. Hassard (Eds.), *Actor Network Theory and After* (pp. 15-25). Oxford, Blackwell Publishers.
- Law, J. (Ed.). (1991). *A Sociology of Monsters. Essays on power, technology and domination*. London, Routledge.

- Macquarie Library (1981). *The Macquarie Dictionary*. Sydney, Macquarie Library.
- Naidu, S., Cunnington, D. & Jasen, C. (2002). The Experience of Practitioners with Technology Enhanced Teaching and Learning. *Educational Technology & Society* 5(1), 23-34.
- Rogers, E. M. (1995). *Diffusion of Innovations*. New York, The Free Press.
- Tatnall, A. (2000). Innovation and Change in the Information Systems Curriculum of an Australian University: a Socio-Technical Perspective. *Unpublished PhD thesis*. Rockhampton, Central Queensland University.
- Tatnall, A. (2002). Modelling Technological Change in Small Business: Two Approaches to Theorising Innovation. In S. Burgess (Ed.), *Managing Information Technology in Small Business: Challenges and Solutions* (pp 83-97). Hershey PA, Idea Group Publishing.
- Tatnall, A. and Davey, B. (2001). *How Visual Basic Entered the Curriculum at an Australian University: An Account Informed by Innovation Translation*. Paper presented at the Informing Science 2001 conference, Krakow, Poland.
- Tatnall, A. and Davey, B. (2002a). Information Systems Curriculum Development as an Ecological Process. In E. Cohen (Ed.), *IT Education: Challenges for the 21<sup>st</sup> Century* (pp. 206-221). Hershey, PA, Idea Group Publishing.
- Tatnall, A. and Davey, B. (2002b). Understanding the Process of Information Systems and ICT Curriculum Development: Three Models. In K. Brunnstein & J. Berleur (Eds.), *Human Choice and Computers: Issues of Choice and Quality of Life in the Information Society* (pp. 275-282). Massachusetts, Kluwer Academic Publishers.
- Townsend, C. R., Harper, J. L. & Begon, M. (2000). *Essentials of Ecology*. Massachusetts, Blackwell Science.
- Ville, C. A. (1962). *Biology*. Philadelphia, W. B. Saunders Company.

## BIOGRAPHY

Arthur Tatnall research interests include technological innovation, information systems curriculum, Visual Basic programming, project management, electronic commerce, and information technology in educational management. Bill Davey's research interests include methodologies for systems analysis and systems development, Visual Basic programming, information systems curriculum, and information technology in educational management. Arthur and Bill are both from Melbourne, Australia and have worked co-operatively together and on many occasions.

# LOGISTICS FOR LEARNING OBJECTS

Bernd Tschiedel, Aleksander Binemann-Zdanowicz and Bernhard Thalheim  
*Computer Science Institute, Brandenburg University of Technology at Cottbus*

**Abstract:** The increasing attention paid to the importance of context-awareness of content has contributed to more useable e-learning websites. While existing approaches mostly cover static learner characteristics, to date it has been difficult to cover the dynamics of context. E-learning content must be delivered in the right doses, at the right moment, and in an appropriate form. Our work presents a storyboarding-based approach for specifying content-intensive websites. E-learning sites can be validated with regard to learner context. The practicability of our method is shown upon the e-learning project DaMiT. The SiteLang methodology helps overcome the limitations of existing approaches based on pre-defined, structuring of content. It allows a flexible content generation upon learner context, depending on the dynamics of the learning process.

**Keywords:** Database, Learner Centred Learning, Learning Systems, Modelling

## 1. INTRODUCTION

Many scientific papers and working group specifications have identified the fundamental insight that a high level of granularity of learning units leads to better user-adaptive systems. One guideline for implementing this is to deal with many different types of units from the same topic. Learners just want the most appropriate content delivered just in time and to the right place and device. They should not be confronted with unnecessary content. Therefore, some services are needed to fulfil the learner's needs. Information logistics can provide acceptable strategies that satisfy the requirements for the delivery of the correct unit of information. The goals of information logistics are readily adapted to the e-challenges of e-Learning.



## 1.1 Information logistics

Information logistics aims to provide optimised information—to serve textually correct and needed information at the right time and place—to users (Lienemann, 2001). The information should always be adapted to the user's preferences and communication facilities. Lienemann explains some principles in information logistics, which are relevant to e-Learning.

- *Several information sources:* The user looks for additional or extended information in distributed, correlated content bases. At the moment we restrict this to one database of one domain.
- *Information on the tick:* Information at the right time depends on the value of the information and the user's context. The value depends on the deliverable content in the knowledge bases. High value demands a detailed description of the content. Users of an e-Learning system may interact with the system in different roles with special characteristics. This is the primary context for the user. The system has to choose, on demand, what the preferred content for the user at any given moment.
- *Consideration of user preferences:* Applications of information logistics must be able to satisfy the individual needs of the users. User needs must be specified for optimal operation and implemented in an explicit and an implicit way. Explicit data, like the preferred presentation style or difficulty, must be treated as granularly as possible. Implicit data are the user's history, current and recorded interaction and utilization behaviour.
- *Flexibility of presentation:* Users have (depending on their working place and working context) different communication devices and channels. The system automatically recognizes the user's system, the network connection and application. In any case, the presentation style must be adapted according to the individual working context.

The *working place and context* are features of information logistics. They do not belong to a web-based e-Learning environment, as they depend on Internet access. The issues described above are related to the challenges our department faced during the development of the *SiteLang* approach.

## 1.2 Challenges in e-Learning

While creating an e-Learning application there are challenges that have already been investigated and adopted. It is also necessary to restrict the aforementioned aspects of information logistics in the following aspects:

- *Full flexibility:* E-learning services require full flexibility of learning scenarios. The set of scenarios necessary to be supported looks graphically similar to a complete graph. It is possible in such cases to use any menu point and to jump to any other dialogue step (Caumanns,

- 2000). The usage of a proven scenario theory for the application development is a basic assumption to realize full flexibility.
- Multiple usage of content: Content authors must be able to index, research, reselect, recombine and update existing content. This demands a flexible data structure. For this reason we adopt learning objects based on the Reusable Learning Object Strategy (Cisco Systems Inc., 2001).
  - Adaptivity: Learners want to get content depending on their specific information requirements. There are some general user profiles in the area of content format like text or formula-oriented learners that can be used to create pre-made scenarios with associated learning objects. To realize full user adaptation, learning objects should be enhanced at run-time with specific user information from the current user profile.

## 2. THE SITELANG METHODOLOGY

The *SiteLang* methodology facilitates the verification of the behaviour of an information service before its actual implementation. It supports the stepwise development of a website (Feyer et al., 2000) and allows the parallel specification of database behaviour and user interaction of the system. The major goals we have achieved are the ability to refine the obtained *SiteLang* specifications and the possibility of executing and validating an abstract specification at any level of abstraction. This has been achieved thanks to the operational semantics of Abstract State Machines (Gurevich, 1993) that *SiteLang* is based on.

The *SiteLang* language comprises constructs for specifying *database functionality* (database schema, database operations, transaction management, integrity constraints, database content), as well as *user interaction* (event-driven interaction model, multiple users and devices, scenes, dialogue steps with transaction semantics, dialogues, media objects) (Düsterhöft, 2001) in parallel. It allows the specification of distributed system architectures. The user interaction model of *SiteLang* is event-driven; the event frame differs from the classical ECA model and comprises well-founded transaction semantics.

*SiteLang* has been successfully used for specifying interactive services of a set-top-box-based television platform that has been developed by an industrial consortium in cooperation with our database group. The positive experience of *SiteLang* has proven its suitability for specifying data-intensive applications. It is also suitable for specifying and validating systems in which the interaction flow is reciprocally influenced by semantic content structures.

### 3. THE DATA MINING TUTOR PROJECT

The focus of the DaMiT project is the development of a computer-based tutor system to support learning and teaching in the area of Knowledge Discovery and Data Mining. Another important focus is put on the creation of content. The main goal of DaMiT is to provide user-context-aware content. Derived sub-goals are: content generation, creating coherent and consistent content, generating a semantic network using the domain Data Mining, integrating applications for on-line data mining, keeping an architecture open for extensibility and updating, as well as obtaining a knowledge basket adoptable to other projects.

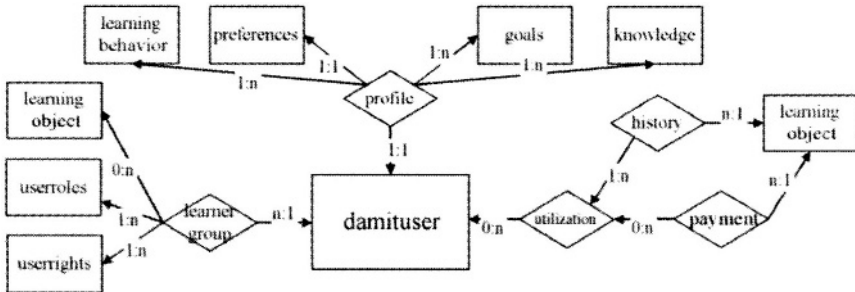

Figure 1. Simplified ER-Schema for DaMiT users

#### 3.1 Modelling the User

For user-context-awareness it is essential to analyse the most typical characteristics, operations and expectations of users who are to work and interact with the planned web service. This concerns the area of rights, educational classification and utilization behaviour. Thus we defined roles (*Content Provider, Teacher, Administrator, Tutor, Learner* with the sub-roles *Anonymous, Pseudonymous, Standard, Manager*), metadata and added functionality, e.g. *Payment, Rights Management* (of courses, with respect to learner groups), as well as user-role-dependent interface and system functions. The refinement process led us, through the (partially depicted) ER schema, to an appropriate relational database schema.

#### 3.2 Modelling Content

Content and content-related user interaction is modelled in *SiteLang* on various abstraction levels. Content can be seen as a semantic structure with

associated metadata. In the stepwise refinement process of *SiteLang* the semantic structure is mapped to an appropriate relational schema. Through this refinement a more thorough validation of system behaviour is possible, as we deal with well-defined database structures and a rich story specification. The specification can again be refined by adding implementation-related details, e.g. distributed architecture, information containers exchange etc. The semantic structure of content is modelled by means of a *content graph*—analogous to the concept of semantic nets.

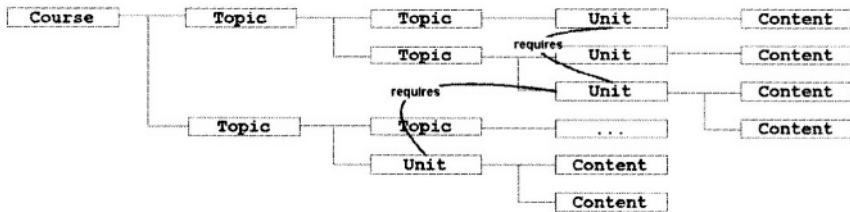

Figure 2. Simplified content graph

Topic-nodes represent the aggregation of units and topics. Units are the smallest pieces of ‘customisable’ knowledge for the learner and contain several types of atomic content items. Topics and Units are contextual described by a subset of IMS Metadata (Global Learning Construction, 2001).

During the *SiteLang* specification process, the content graph is mapped to a database schema. Classes of objects of the same type in the content graph are mapped to relationship types, links between objects are mapped to relationship types of a higher order. The resulting schema depends on the types of links between nodes on the BUL and of their semantics with respect to learning scenarios, as well as on e-learning content type and paramount manipulation operations performed on the content. As a result we get a complete relational database schema with the corresponding metadata and the user information.

User interaction is specified explicitly. Navigation through content is realized as an execution of a series of scenes; navigation steps through a single unit by means of dialogue steps of a single scene. The scene specification is derived from the content definition. Content graph modifications at run-time result in changes of the derived scene specification.

The obtained conceptual specification can be refined, e.g. by including further implementation details and by adding constructs describing system

distribution. Metadata in DaMiT is modelled according to commonly known ideas. It is modelled in *SiteLang* on the BUL directly by means of the HERM model (Düsterhöft & Thalheim, 2001). The metadata schema is then transformed to a corresponding relational schema.

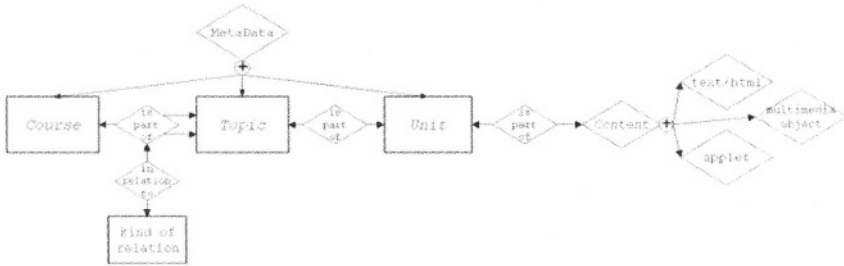

Figure 3. Simplified ER-schema for DaMiT content

### 3.3 Content Generation

e-Learning content in DaMiT is generated according to the user's needs and is closely related to content-adaptivity. This is done in two ways.

- *Content-to-Context Matching*: the existing content structure is matched with the user's preferences and history. The generated content is assembled from the matching topics and units, chosen from the content graph and is presented to the user as a *lesson*. It is being realized in our prototype by means of parameterised views and mappings of user-context-dependent generation rules. The currently implemented generation method is conform to the top-down approaches, further development of the system will comprise an implementation of the bottom-up approach (Caumanns, 2000).
- *Semantic Content Evolving*: the content structure is enriched by new subgraphs built on the basis of common learning objects. The new lessons can be more valuable to the learner, as they have new semantic relationships previously not present in the content graph; they are also reusable for later usage. Representing content generation rules in *SiteLang* is subject to further research.

### 3.4 Content Versioning with SiteLang

In the learning process, it is essential to provide every user with the correct content version. To do this, the following needs to be considered:

- *Content Stability*: After the user has begun a course, any changes on the course content must not be released to the user as long as he has not

completed it. This intuitive condition cannot be realized in a trivial manner, i.e. just by freezing the course version, as it would cause an overhead when dealing with massive amounts of users.

- *History Continuance*: Older content versions may need to be kept for later usage. It must be possible to recall any older version at any time.
- *Similarity Versioning*: Depending on the user's knowledge and usage history, it may be necessary to use different parallel versions of the same content, which are assigned to the same unit. For instance, there may be different difficulty versions of the same content, e.g. 'basic', 'intermediate', 'advanced'. Such parallel versions may also be subject to 'classical' versioning in terms of updating content, e.g., for improvement.

### 3.4.1 Content Modification Versioning

Course (content) modifications occur by integrating a new subgraph into the existing content graph, by deleting a subgraph or by updating a node. To preserve content stability when a course modification is made it must not affect unfinished interactions related to the course. New interactions may be started after the modification: the new version should be applied to them.

- *Course Versioning*: Each course is versioned separately.
- *Extending courses*: Adding a subgraph (into the content graph) increases the course version. All vertices and edges of the subgraph also get the increased version. The new edge leading from the existing graph into the added subgraph also receives the new version number.
- *Removing course parts*: Removing a subgraph from a course increases the course version and adds another edge of type *deleted* from the subgraph's father to the subgraph.
- *Updating courses*: Updating a node in a course (topic, unit or content node) increments the course version and creates a new node of the same type which is connected with the same nodes and by new edges of the same type as the original node; the new edges' version is incremented.

### 3.4.2 Maintaining Parallel Unit Versions

Versioning is also an important aspect of user adaptivity on e-Learning content, as it is necessary to provide users with content of appropriate difficulty level. Therefore, multiple units with similar content of varying difficulty are grouped in a topic that is specially marked with the property *unit group*. In this way, a group of units on the BUL can be identified as 'similar units'. The transformation into the Conceptual Layer is analogous to the one of the entire content graph.

## 4. SUMMARY

We have presented a methodology for specifying information logistics for e-learning applications. It is based on the operational semantics of Abstract State Machines and has proven suitable for specifying content adaptivity in the DaMiT project. Further research will be focused on deeper aspects of context-aware content generation. The DaMiT system is to be enhanced by means of implementing bottom-up content generation (Caumanns, 2000). Details of the actual top-down approach are accessible to the public at the URL <http://neumann.dfki.uni-sb.de/damit>.

## REFERENCES

- Caumanns, J., (2000). *Automatisierte Komposition von wissensvermittelnden Dokumenten für das World Wide Web*. Unpublished PhD thesis. BTU Cottbus.
- Cisco Systems Inc. (2001, November) *Reusable Learning Object Strategy*, (Ver. 4.0).
- Düsterhöft, A., & Thalheim, B. (2001). Conceptual modelling of Internet sites. in *Lecture Notes in Computer Science* Vol. 2224. (pp. 179-192). Berlin, Springer.
- Feyer, T., Odey, K., Schewe, K. & Thalheim, B. (2000): Design of data-intensive web-based information services, in L. Qi. et al. (Eds.). *WISE 2000. Proceedings of the First International Conference on Web Information Systems Engineering*, Hong Kong. IEEE
- Y. Gurevich, Y. (1995). *Evolving Algebras 1993: LipariGuide, Specification and Validation Methods*. Oxford University Press, pp. 9-36
- Global Learning Construction Inc. *Meta Data Specifications*, retrieved from <http://www.imsglobal.org/metadate/index.cfm>
- Lienemann, C. (2000). *Informationlogistik-Qualität im Fokus*. Institute of Computer Science, Cottbus, Symposion Publishing.

## BIOGRAPHY

Bernhard Thalheim held professorships at Dresden, Kuwait, Rostock, Cottbus and is now at Kiel. He works on relational data model theory and pragmatics of Entity-Relationship modelling, object oriented databases and their design. Aleksander Binemann-Zdanowicz's work explores the semantics of conveying learner-specific content in e-learning applications. Recent work includes method development for specifying and validation of content-intensive websites. Bernd Tschiedel, is responsible for the database development.

## ACKNOWLEDGEMENTS

The authors wish to thank the participants of the DaMiT-Project, Oleg Rostanin, Martin Memmel and Klaus Jantke, along with other colleagues, for their support and encouragement.

This research was partially supported by the DFG, Berlin-Brandenburg Graduate School in Distributed Information Systems (grant no. GRK 316).





# IMPLEMENTING THE LEARNER-CENTERED DESIGN PARADIGM FOR WEB-BASED TRAINING CURRICULA

Panagiotis Zaharias and Angeliki Poulymenakou  
*Athens University of Economics & Business, Greece*

**Abstract:** e-Learning environments provide exciting possibilities for learning and training, but dropout rates are high and the quality of e-Learning courses is being questioned. Capturing requirements, and developing usable e-learning courses, focusing on usability and user-centred design are of high importance. Such efforts must be redefined for e-learning contexts. This paper stresses the need for usable and effective e-learning design and describes the authors' experience in adapting methods and techniques of human-centred design implementing a learner-centred approach to the design e-Learning.

**Keywords:** design-technology, learner-centred design, learning materials

## 1. INTRODUCTION

e-Learning environments and courses provide exciting possibilities for supporting a wide spectrum of learners: students in schools and universities, business professionals seeking new training experiences, adult learners in general under the lifelong learning context. However, the focus of e-Learning is often far more on technology issues and not on the quality of learning—focus on the 'e' and not on 'learning'—with techno-centric design (Lohr, 2000) being the dominant approach. As a consequence dropout rates are high and this is a serious concern (Murray, 2001; Diaz, 2002). Figures on the dropout rates for e-learning courses vary; it is estimated that between 30-75% of students fail to complete e-learning courses (Ganzel, 2001).

The poor design of e-learning courses is a basic reason for the dropout rates. Poor usability compounds this attrition problem by causing frustration or creating unnecessary barriers to completing e-learning courses (Notess, 2001). Usability can play a key role in creating a positive user experience; usability is not an *add-on* feature but must be *built-in* (Nielsen, 1994; Shneiderman, 1998; Maguire, 2001). To ensure the latter, the human-centred design paradigm (HCD) must be adopted for e-Learning design.

This paper describes the authors' efforts to adjust the methods and techniques of HCD to e-learning projects (a web-based training curriculum) thus implementing a learner-centred design. The TrainSEE project (Zaharias and Poulymenakou, 2003a) provides the context for our work. It is an e-learning project aiming at enhancing ICT skills in South-Eastern (SE) European countries. The determination of the ICT skills and competencies to be offered, and hence the creation of the corresponding e-learning service (web courses), is guided by the *Generic Skills Profiles for the ICT Industry in Europe* ([www.career-space.com](http://www.career-space.com)). The following sections describe the authors' experiences in the design and development of the web courses for the TrainSEE project.

## 2. LEARNER-CENTERED DESIGN OF WEB-BASED TRAINING COURSES

HCD is concerned with incorporating the user's perspective into the software development process in order to achieve a usable system (ISO, 1999). User-centred design is a process of integrating user requirements, user interface validation, and testing into standard software design methods. It views knowledge about users and their involvement in the design process as a central concern (Preece et al., 1994). These two terms are now used interchangeably. Focusing on HCD means involving users in the process of designing a particular product, understanding their needs, and addressing them in very specific ways (Maguire 2001). Our main concern was to involve trainees early in the design process in an active way that would engage them, thus helping the designers to design a *learner-centred* e-learning service. Nevertheless, we had to make adjustments since the e-learning projects have their own difficulties and particularities: learners have their own special needs and they differ from the typical users of software applications. Smulders (2002) reflects on the 'double persona' of the learner-user duopoly. In addition, learning is a quite different task from those that typical software users have to perform. Learning cannot be approached as a conventional task, as though it was just another kind of work, with a number

of problems to be solved and various outputs to be produced (Mayes and Fowler, 1999).

The following describes our efforts to adapt the methods and techniques of HCD and web-based instructional design to an e-learning project. The structure of the description is provided by Maguire (2001) who identifies the five essential processes that should be undertaken in order to incorporate ISO 13407 usability requirements into the software development process. These are described below. It has to be clear that these steps are not necessarily linear in sequence. Rather than that many sub-activities can go in parallel and the whole learner-centred design is an iterative process.

## 2.1 Plan the human (learner) centred design process

The aim in the first phase — *usability planning and scoping*, is to bring together the several stakeholders to discuss the project objectives and to create a vision of how a learner-centred design approach and usability considerations can contribute to the project's objectives. They also served to identify the stakeholders. During this phase several meetings of representatives of all of the stakeholders were held. Some of the main issues were the project's overall objective, the user organizations and their needs, the trainees and their profiles and technical and environmental constraints.

## 2.2 Understand and specify the context of use

This stage involved:

- *Surveying the general characteristics of trainees*: Since the trainee population was diverse and geographically dispersed, we distributed a survey through email and asked the heads of the trainees in each user organization to provide us with a generic description of the trainees' background, academic education, skills, main job-related responsibilities as well as an estimation of the number of trainees that will use the e-learning service of TrainSEE project.
- *Task Analysis*: Methods and tools from instructional design practice were used to perform this activity (Nelson et al., 1995). Task analysis is used to determine the knowledge, skills, tools and requirements needed to perform a job; it goes in parallel with training needs assessment. During this phase a combination of data gathering methods such as interviews and surveys were used. This facilitates the task of developing the most appropriate training materials and content. Only tasks that had a perceived high performance gap (Zaharias & Poulymenakou, 2003a) were selected.

### 2.3 Specify the user and organizational requirements

This involves a number of stages as described below:

- *Existing system/ competitor analysis*: an informal analysis of existing e-learning courses on ICT topics and e-learning authoring tools was conducted. This process although conducted in an unstructured way provided significant input for the design of the web-based courses, especially for usability problems' identification.
- *Focus group*: a focus group was organized that brought together five trainees and their supervisor representing one user organization, and members of the design team. During this focus group a brief introduction of the main concepts of the project was given. The first part of the focus group was accompanied by further discussion focused on prior training experiences of the trainees, their special ways of learning, their opinions and attitudes towards web-based training methods and their expectations regarding the TrainSEE e-learning service and web courses. The second part of the focus group included a short presentation about the learning environment (selected in the previous phase) where the web courses would be uploaded; additionally an early prototype of the web courses was presented. Actually this was an effort to initiate a participatory kind of evaluation known as evaluation walkthrough. The presentation was a process of going step-by-step through the web courses and the e-learning environment aiming at receiving feedback from the stakeholders (in that case the trainees' supervisor) and the trainees themselves.
- *User requirements*: these were captured by two sets of activities:
  - Trainee-level requirements: A survey was used as the main source for capturing information along a wide spectrum of variables that affect successful implementation of learning applications: a) Trainees' learning styles and preferences, b) Trainees' motivation (extrinsic) for taking the web courses, c) Trainees' special ways of learning (learning habits), d) Trainees' attitude towards several training methods and e) Trainees' past training experiences. Interpretation of the results was facilitated by the relevant literature (Kolb,1984; Honey and Mumford, 1992).
  - Organizational-level requirements: This activity was quite critical; a framework for training needs assessment (Ostroff and Ford, 1989) was followed that facilitated the identification of the organizational-level requirements in terms of training needs of each user organization. This framework combines the dual perspectives of content (person, task, organizational) and levels (individual, subunit and organizational).

This systematic approach (including organizational dimension) was considered essential in our case, since the e-learning service is a new experience for the user organizations. The methodology for conducting training needs assessment was basically guided by a) Content levels framework (Ostroff and Ford, 1989) and b) Generic Skills Profiles for the ICT Industry in Europe (Career Space project, 2000). In this phase questionnaires and interviews were used as main instruments for data collection. The main result of this phase was the selection of two broad areas of skills and competencies that the web-based courses had to address: a) S/W & Applications Development and b) IT Business Consultancy. More details for these two broad areas of skills and competencies and the relevant task and job analysis can be found in Zaharias and Poulymenakou (2003a).

## 2.4 Design

- *Design guidelines*: Our initial design efforts included a thorough review process of web design guidelines (Nielsen, 2000b; Lynch and Horton, 1997) and Instructional Design guidelines and frameworks (Weston et al., 1999; Johnson and Aragon, 2002) in order to effectively integrate web design and instructional design guidelines. Individual differences, motivation, information and cognitive overload, consistency, navigation support, online help and documentation and adult learning principles were also considered in the interface design process.
- *Storyboarding*: Storyboards are sequences of images that show the relationship between user actions and system outputs (Nielsen, 1991). They were developed to gather information regarding the structure, functionalities and navigational options of web courses. They were used as a basis for initiating constructive discussions among the members of the design and development team and the subject matter experts.
- *Software prototype*: A software prototype exhibited the interface and actual content of two learning modules. It was a high fidelity prototype as most of the functionalities were incorporated, whose purpose was to have a small set of trainees interact with a more realistic subset of the learning application. Trainees were asked to freely explore the software prototype; no specific tasks or scenarios for interaction were given at this phase. The trainees were interviewed about their experience with the web courses. Questions focused on the course content and its relevance to the trainees' needs and job tasks, the difficulty level of the courses, navigation through the courses, the interactivity level, the clarity of learning objectives and their general impressions of the course.

## 2.5 Evaluation

Evaluation is a critical phase for our work and it is focused on gathering as much qualitative and quantitative information from the stakeholders especially from the trainees themselves. Usability and its testing were the main pillars in our evaluation activities. Usable learning environments and courses are supposed to contribute to educational and training goals (Jones et al., 1999). Usability testing can have a significant impact on the instructional product development cycle as well as the instructional systems design process (Lee, 1999). Our evaluation plan consists of five steps:

1. *Evaluation walkthrough*: The first step towards evaluation of the design was the evaluation walkthrough as described in *focus group* section.
2. *Interaction with software prototype*: The second step was set up by having five trainees interact with the software prototype. This was accompanied by interviews as described in the previous section.
3. *Content quality control*: Five subject matter experts were involved in this evaluation activity. A short checklist focusing on quality of instructional content and materials was created by the instructional designer (member of the design and development team) and used by the evaluators.
4. *Heuristic evaluation*: This is an expert-based inspection of the courses. Design changes have been made based on the recommendations of two expert evaluators, Given the time constraints the redesign focused only on the most severe usability problems.
5. *Usability testing*: a sample of trainees will perform a number of tasks while interacting with the courses. The tasks are based on training needs assessments and task analysis, trainees' learning styles and preferences and the instructional strategy used throughout the course. This occurs in the user organization's environment to ensure that the testing will occur under conditions close to the 'real' ones. It will be accompanied by interviews and satisfaction questionnaires.

The heuristic evaluation has been completed while the usability testing is forthcoming. Evaluating e-Learning '*may move usability practitioners outside their comfort zone*' Notess (2001) since they need to familiarize themselves with learning theories, evaluation frameworks and instructional design methods. Problems emerged in the heuristic evaluation: the experts have expertise in the human factors area but they had difficulties when trying to interpret the heuristics for learning and instructional design. Also, difficulties arose when trying to define a set of 'representative tasks' for the usability test. Researchers and practitioners have to be aware of the difficulty of defining and measuring learning and relevant tasks; they must also refine the current usability evaluation methods since there is a scarcity of such methods customized for e-Learning.

### 3. CONCLUSION AND FUTURE RESEARCH

We discussed how the learner-centered design paradigm can be realized to ensure quality in e-learning experiences. Capturing requirements, designing and developing usable e-learning courses, focusing on usability and iterative design are of high importance. Special attention must be paid on the specificities of e-learning projects; learner (and e-learner) is not a typical type of software user. Learning is not a conventional type of task. Future research needs to focus on such specificities: new frameworks for capturing e-learning requirements are needed, usability and its dimensions must be refined to fit in e-learning context, new usability evaluation techniques have to emerge combining usability, learning theories, and instructional design guidelines. Research efforts must be initiated, supported and empirically validated. The results are expected to shed light onto the most neglected parts of e-learning: enhancing the 'learning' rather than 'e'.

### REFERENCES

- Career Space project, (2000). *Software & Applications Development job profile*. Available at <http://www.career-space.com/downloads/index.htm>
- Diaz, D. P. (2002). Online Drop Rates Revisited. *The Technology Source*, May/June 2002. Available at <http://ts.mivu.org/default.asp?show=article&id=981>
- Ganzel, R. (2001). Associated Learning, *Online Learning Magazine*, May. Available at <http://www.onlinelearningmag.com/>
- Honey, P., & Mumford, A. (1992). *The manual of learning styles*. Maidenhead: Peter Honey
- ISO (1999). *Human-centred design processes for interactive systems*. Geneva: ISO
- Johnson S., & Aragon S. (2002). An Instructional Strategy Framework for Online Learning Environments. In proceedings of *World Conference on E-Learning in Corporate, Government, Healthcare & Higher Education*, (pp. 529-536). Norfolk, VA: AACE
- Jones, A. et al. (1999). Contexts for evaluating educational software, *Interacting with Computers* 11 (5) 499-516
- Kolb, D. A. (1984). *Experiential learning*. Englewood Cliffs, N.J.: Prentice-Hall
- Lee, S. H., (1999). Usability Testing for Developing Effective Interactive Multimedia Software: Concepts, Dimensions, and Procedures. *Educational Technology and Society*, 2(2), 20-29.
- Lohr, L. L. (2000). Designing the instructional interface. *Computers in Human Behaviour*. 16 161-182.
- Lynch, P. J., & Horton, S. (1997). *Web Style Guide Basic Design Principles for Creating Web sites*. Yale University Press. Available <http://www.info.med.yale.edu/caim/manual>
- Maguire M. (2001). Methods to support human-centred design. *International Journal of Human-Computer Studies*, 5, 587-634.
- Mayes, J. T., & Fowler C. J. (1999). Learning technology and usability: a framework for understanding courseware, *Interacting with Computers* 11(5) 485-497.
- Murray, B. (2001). What Makes Students Stay? *ACM eLearn Magazine*. (May). Available at <http://www.elearnmag.org/>



- Nelson, R. R., Whitener, E. M., & Philcox, H. H., (1995). The Assessment of End-User Training Needs. *Communications of the ACM*, 38(7), 27-39.
- Nielsen, J. (2000). *Designing web usability: The practice of simplicity*. Indianapolis: New Riders Publishing.
- Nielsen, J. (1994). Heuristic evaluation. In J. Nielsen & R. Mack (Eds.), *Usability inspection methods*. New York: John Wiley & Sons.
- Nielson, J. (1991). Paper versus computer implementations as mock up scenarios for heuristic evaluation. In D. Diaper, et al.(Eds), *Proceedings of the IFIP Third International Conference on Human-Computer Interaction* (pp. 315-320). Amsterdam: North-Holland
- Notess, M. (2001). Usability, User Experience, and Learner Experience. *ACM eLearn Magazine*. [Tutorial]. Available at <http://www.elearnmag.org/>
- Ostroff, C. and Ford, J. K. (1989). Assessing training needs: Critical levels of analysis. In *Training and Development in Organizations*. Jossey-Bass, San Francisco, 1989, 25-62
- Preece, J., Rogers, Y., Sharp, H. et al., (1994). *Human-computer interaction*, Workingham, England: Addison-Wesley.
- Shneiderman, B. (1998). *Designing the user interface: Strategies for effective Human-Computer Interaction*. (3<sup>rd</sup> edition). Addison Wesley.
- Smulders, D., (2002). Designing for Learners, Designing for Users. *ACM eLearn Magazine*. Available at [http://www.elearnmag.org/subpage/sub\\_page.cfm?section=3/](http://www.elearnmag.org/subpage/sub_page.cfm?section=3/)
- Weston, C., Gandell, T., McApline, L., and Filkenstein, A. (1999). Designing Instruction for the Context of Online Learning, *The Internet and Higher Education* 2(1), 35-44
- Zaharias, P., Poulymenakou, A. (2003a). Identifying training needs for ICT skills enhancement in South-Eastern Europe: Implications for designing web-based training courses *Educational Technology & Society*, 6 (1). Available at <http://ifets.ieee.org>

## BIOGRAPHY

Panagiotis Zaharias has research interests in the design and usability evaluation of e-learning courses (mainly asynchronous, self-paced web courses) and technologies. Angeliki Poulymenakou has research interests in the organizational and social implications of e-learning and knowledge management implementation.

## ACKNOWLEDGEMENTS

TrainSEE is funded by the European Commission's Information Society Technologies (IST) programme. We wish to acknowledge INTRASOFT International, Open University of Catalonia, Lambrakis Research Foundation, Athens University of Economics and Business, Public Power Company of Greece, Bulgarian Telecommunications Company, LOGO Business Solutions, National Oil Company PETROM, IBM Central and Eastern Europe/Middle East/Africa Inc, Bulgarian Academy of Science, and ISIK University.

# IMPLEMENTATION AND USE OF A WEB-BASED LEARNING ENVIRONMENT

## *The case of Control Web*

Juha Lindfors

*Department of Research Methodology, University of Lapland. juha.lindfors@ulapland.fi*

**Abstract:** University teaching has been under pressure to change in recent years due to the financial pressure to decrease resources, the need to keep the quality and quantity of education offered high, and to give due consideration to changes in technology and learning methods. One response to these pressures has been to study if it is possible to build a rational learning environment for Control Engineering using modern technology. It could make studying more efficient by enabling better follow-up of learning and the use of interactive functions. The development of a web-based learning environment for Control Engineering started from a simple model of learning theories and course content; the model was applied to the Control Engineering context, and the learning environment was developed and implemented. The implementation is referred to as Control Web. Functions were added to Control Web and tuned according to student feedback. Student feedback, and grades during the years 1993 to 2000 were analysed. According to the results, the system implemented has performed well. However, the explicit influence of using the web-based learning environment can be seen in only few cases. The results and experiences yield an enhanced model for developing a web-based learning environment.

**Key words:** Learning systems, Internet, higher education

## 1. INTRODUCTION

The function of teaching, and the University as a whole, has changed because of the impact of many external factors, of which some are as follows (Bates, 1997; Karran, 2000).

- The growth of the Internet has led to enhanced access to learning tools and technologies for all citizens; new groups are involved in learning.
- Technology has provided an opportunity for a larger group of people to access learning and learning materials to the extent that the materials are freely available on the WWW.
- An increasing need for more education and training, for example the growing need for lifelong learning, has emerged because of changes in business and everyday life. This means that many people are forced to change their profession during their working years, perhaps several times.
- New paradigms and ideas for learning have developed that emphasize interactive learning and teaching.
- Economic considerations set new requirements. For example, in some cases, distance learning is the only means to provide learning to student groups located in several places, and thus modern technologies make it possible to save on costs. It also provides tools to respond to the requirement that all citizens should have equal educational opportunities.

It seems as if educational authorities aim to increase the productivity of teaching, meaning that they are paying more attention to the quality and efficiency of teaching. In the current economic situation, educational demand exceeds the limits of existing resources and the gap between them has to be filled, for example, by using modern methods and technology.

When the 1990s began, hypermedia was taken seriously and numerous studies were conducted throughout the world. The possibilities of hypermedia were also noticed in the Control Engineering Laboratory of the University of Oulu in the year 1990 where they took shape in the form of a hypermedia development project in the COMETT II programme. The project started in 1990 and lasted three years. The development of hypermedia packages continued after the project, and new modules were subsequently implemented and added to the collection. When the network was developed to a level where it could be used effectively in teaching, it was naturally taken into account and modern networked materials were developed for the use of students.

A virtual laboratory (VL) is one solution to meet the new demands posed by the changes in the domain on the one hand, and in teaching resources on the other. In co-operation with traditional teaching environments, a VL improves teaching and learning at the laboratory level in order to yield effectiveness and increased quality. A narrow interpretation of a VL defines it as a heterogeneous, distributed environment that enables a group of students at various locations on the Internet to work together on a common set of problems or projects. As with any other laboratory, the tools and

techniques are specific to the domain, but the basic infrastructure requirements are shared across disciplines.

Modern learning environments that are based on networks do not displace older environments; both are needed and can support each other. One interesting question is how to find a reasonable balance between different approaches and environments? Undoubtedly, the ratio of the use of modern and traditional learning environments varies between disciplines and courses.

## **2. IMPLEMENTATION**

The development of most modern learning environments has largely been based on various learning theories. These kinds of environments set out to achieve a particular functionality based on a theory of ‘learning actions’ according to the theory in question (Korhonen, 1999). However, modern learning environments can also be developed from other starting points. One such alternative origin is rooted in the special needs of a course — this kind of learning environment is typically developed along with the course in an iterative, grounded praxis. The basis for such development is a need to solve a special course-related problem such as a particularly large enrolment or control of the learning process. The latter was the problem that was addressed in the development of the Process Control II course. The acuteness of the problem has led on to the use of alternative learning methods — as opposed to alongside — the traditional methods. In this case, both points of view have influenced the development of the Control Engineering learning environment as discussed below.

The Control Engineering Web-based learning environment was built in several stages on the Internet server of the Control Engineering Laboratory and was used in everyday teaching. The experiences gained have also been used in re-designing other control engineering courses. Students had access to the system using normal Internet connections. Changes in the learning environment were made according to the feedback and experiences gained during its use.

## **3. PROCESS CONTROL II**

Graduates of this course should be able to design and carry out industrial experiments using common design methods e.g., Hadamard matrix, Central Composite Design and Taguchi, and using a range of statistical analysis methods to analyze the results obtained in such experiments. Course

exercises consist of experimental design projects that students carry out in teams of at most five students; experience indicates that four seems to be optimal number. The teams study a particular process, which is usually based on the use of a rotary dryer. The teams examine details of the model and a dryer simulator. Based on this study the teams define the variables they need to use to design their experiments using a Hadamard matrix, and then carry them out using the simulator. Results are presented to the other students on the last day of exercises and also in the WWW environment. The simulation exercises are done partly independently and partly in a laboratory.

In the independent part of the simulation, the students are expected to do their preliminary tests on the WWW and, according to the results, choose the variables to study and to design the experiments. Independent study occurs largely over the WWW; the students can also use the WWW materials to support their work. Independent study means that the students deepen their knowledge on the subject by using the WWW resources. This part also contains the preparation of a written report on the experiment design project, and familiarisation with the network learning environment

There is little or no time for collective practice with the environment. An assistant helped students when they needed it, which proved to be quite a good strategy. In the beginning the assistant got only few emails concerning the use of the environment; in other words, the use of the environment seemed to be straightforward to the students. The use of the environment was studied once in the exercises, which took about one hour of time.

The course is given in the last period of the academic year (in the spring.) Three main problems have affected the implementation. Firstly, the students begin to leave for their summer jobs during the course. Thus they are spread all over the country, with some of them even abroad. The network component binds them to the course. Secondly, holidays during the period disrupt studies and, finally, May 1<sup>st</sup> activities at the end of the period further distract the students.

The number of exercise days varies according to the calendar. There are usually 8-10 days for exercises. The first is the motivation day. General aspects of the exercises are taken up, such as how to carry out the exercises, form the teams, additional exercises, what programs are needed, where to find them, and how to find things on the Web. The participation of all students is recommended. The same applies to the second day, when the experiment design part begins.

After the first two days, the teams go on with their work according to their own schedule. However, there are certain days when the assistant is available to the students if they want to do something under guidance or ask advice. Participation in the exercises is not compulsory, but is highly valued.

It has been observed that students who are absent miss out important information.

#### **4. STRUCTURE OF THE CONTROL WEB**

Building the Control Web environment started as early as 1995. Initially a hierarchical structure was chosen. Subsequently, development of the structure has been based on student feedback, which has led to the development of guidelines for the structure and functions that need to be included in the environment. Other guidelines have been adopted from other environments as the results of other studies of similar Web services have become available (Manninen, 1999; Lifländer, 1999). Also, closed learning environments (TELSIPro and Proto) were studied when they were introduced on the market.

The Control Web environment consists of hyperlinked WWW-pages that connect all the materials together. There is a main page for Control Web, which includes the link to the educational pages. The structure of the Web courses can be based on functions or on courses. The 'functions approach' means that separate pages correspond to distinct functions of the courses such as course descriptions, schedules, and the results of examinations. A division by functions means that, for example, the administration links for all the courses are on one page.

The other method is to keep the courses intact and include all the functions and information concerning a specific course in one place. According to the student's feedback, the division by courses is clearly preferable, and it is used in this application. The division-by-courses method was chosen initially because it was believed to be as good as division by functions, which was not implemented in this study. According to the responses on the questionnaires, the structure was both clear and functional for the users. Moreover, it was easy for the administrator, because the folder structure in the Internet information server is similar. In the physical folder structure each course has its own folder where the WWW pages of the course are located. One disadvantage of a division by courses is that it may lead to the repetition of pages, which can cause version-control problems. For example, in our solution, each course has its own page for grades, whereas in the division-by-functions solution grades would be on a single page. In the division-by-course solution, pages are connected by hyperlinks to each other and the solution uses shared pages whenever possible.

### 5. FINDINGS

The grades students earned on examinations during the years 1993-2000 were one of the factors studied. These are the years in which the course Process Control II was developed and new methods were taken into use. The results of examinations show that the changes in the teaching methods on the courses affected the distributions of the grades. Studying results from several years after the change can show the effect of methods and whether improvement has been achieved.

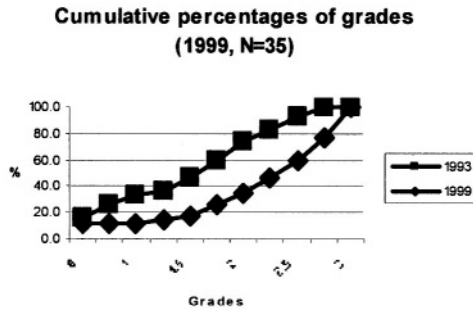

Figure 2. Distribution of grades in Process Control II in 1999

The cumulative percentages of grades in each year have been calculated and plotted on the chart along with the values for year 1993, which reveals the drop in failing grades and the shift in grades. Figure 1 presents one of the best years. The results of other years are similar to those of 1999. The analysis of fails can be a tool for teachers to identify when course parameters need changing.

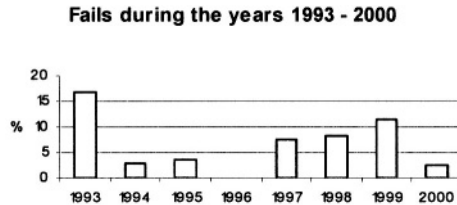

Figure 2. Fails in Process Control II from 1993 to 2000.

Figure 2 shows the percentages of fails from 1993 to 2000. A distinct drop in the number of fails can be seen in 2000, which was a year when the Web-based learning environment platform was used extensively.

## 6. CONCLUSIONS

According to the responses on the questionnaires, the structure of the Control Lab learning environment was clear and functional for the users. Moreover, it was easy for the administrator, because the folder structure in the Internet information server is similar. In the physical folder structure each course has its own folder where the HTML files (Web pages) of the course are located.

The results of examinations show that the changes in the teaching methods on the courses affected to the distributions of the grades. Sometimes a change, be it negative or positive, can lead to positive improvement, but studying results from several years after the change can show the effect of methods and whether improvement has been achieved.

On the basis of the results, experiences and feedback, Korhonen's (1999) model for building a learning environment can be enhanced to cover the factors that have been found to be significant. His model can be replaced with Figure 3 (Lindfors, 2002), which presents a model that can be used as the basis for the development of an open learning environment on the WWW.

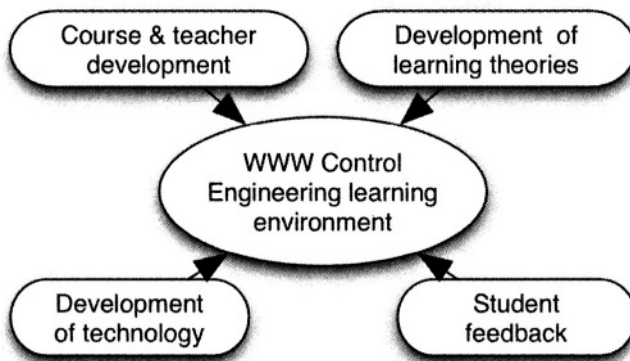

Figure 2. A model for the development of an open learning environment (Lindfors, 2002).

This model also takes into account the dynamic situation. Technology develops all the time, creating new possibilities to introduce better pages. Student feedback is essential after the first prototype of the system is launched; feedback can be used to fine-tune the system. The content of



courses changes over time, and the content of Control Web pages will need updating. The professional and educational abilities of the teacher will also change as time passes. These factors will change the contents of the learning system as different conceptions of learning get support at different times.

## REFERENCES

- Bates, A. W. (1997, 18-20 June). *Restructuring the university for technological change*. Paper presented at the Carnegie Foundation Conference for the Advancement of Teaching: What Kind of University?, London, England. [Online]. Available <http://bates.cstudies.ubc.ca/carnegie/carnegie.htm>
- Karran, T. (2000, 23-24 Nov). *Building Networks for Knowledge Creation: New Roles for Universities in the Information Society*. Paper presented at Koulutusteknologiatori 2000, University of Oulu, Oulu, Finland.
- Korhonen, A. (1999). Kokemuksia erään tietokoneavusteisen oppimisympäristön tuomasta lisäarvosta. *Peda-forum*, 2, 4-6.
- Lifländer, V. (1999). Verkko-oppiminen - Yhteistoiminnallinen projektioppiminen verkossa, Edita 1999, Helsinki.
- Lindfors, J. (2002). *A modern learning environment for Control Engineering*. Unpublished D.Sc. (Tech.), Acta Universitatis Ouluensis, Oulu, Finland.
- Manninen, T. (1999). Computer supported learning and training centre for engineering education. Acta Brahea, Raahe. p. 93.
- Internet2. (2002). The Virtual Laboratory: An Application Environment for Computational Science and Engineering. University Corporation for Advanced Internet Development. [Online]. Available [http://www.internet2.edu/html/virtual\\_laboratory.html](http://www.internet2.edu/html/virtual_laboratory.html).

## BIOGRAPHY

Juha Lindfors Dr. Sc. (Tech.) works as an IT professor in the Unit of information technology at the University of Lapland, Rovaniemi, Finland. His research interests lie in the design and use of e-learning environments for engineering curricula. Recent research and development has focused on developing and implementing modern learning environment for Control Engineering that combines new learning methods and ICT tools..

## Index

- Aarreniemi-Jokipelto, P., 231  
Ahonen, M., 281  
Alamäki, A., 95, 155  
Ala-Mutka, K., 181  
Binemann-Zdanowicz, A., 315  
Blakowski, G., 61  
Brown, A., 247  
Campbell, L., 85  
Clark, T., 85  
Cox, M., 37  
d'Ávila Matoso, M., 171  
Dagiene, V., 103  
Davey, B., 197, 307  
Davis, N., 247  
de Haan, D., 113  
Dowling, C., 205  
Erkkilä, R., 273  
Ferdig, R., 247  
Grigas, G., 103  
Gurubatham, M., 121  
Haaparanta, H., 213  
Heimbürger, A., 291  
Hellstén, M., 51  
Hezemans, M., 129  
Hinze, U., 61  
Holmström, J., 137  
Hyvönen, M., 273  
Jäppinen, A., 281  
Kalli, S., 231  
Kamaja, I., 69, 221  
Ketamo, H., 3, 213  
Kiili, K., 3  
Kontinen, M., 221  
Köppe, H., 299  
Koskinen, K., 273  
Lainema, T., 263  
Lehtonen, M., 11  
Leppänen, V.-J., 137  
Lindfors, J., 69, 221  
Mäkinen, K., 95, 155  
Mattauch, W., 77  
McDougall, A., 85  
Multisilta, J., xi  
Nakayama, M., 163, 171  
Nicholson, P., 19  
Pauniahho, L., 273

- Pehkonen, M., 281  
Pfahl, D., 113  
Pilla, B., 163  
Poulymenakou, A., 325  
Proano, R., 163  
Räisänen, S-M., 181  
Riikonen, T., 231  
Ritzen, M., 129  
Rohs, M., 77  
Ruohonen, M., xi  
Saloheimo, M., 221  
Silveira, R., 163, 171  
Syvänen, A., 281  
Tatnall, A., 197, 307  
Thalheim, B., 315  
Trapp, S., 113  
Tschiedel, B., 315  
Tuominen, J., 231  
Turunen, H., 281  
Vahtivuori-Hänninen, S., 29  
Vainio, T., 281  
Vilenius, J., 273  
Vilenius, M., 273  
Waterson, P., 113  
Wilkinson, L., 37  
Zaharias, P., 325