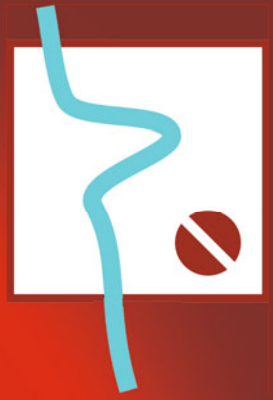


Building Pathology and Rehabilitation



João M.P.Q. Delgado *Editor*

# Case Studies of Building Pathology in Cultural Heritage

 Springer

# **Building Pathology and Rehabilitation**

Volume 7

## **Series editors**

Vasco Peixoto de Freitas

Aníbal Costa

João M.P.Q. Delgado

More information about this series at <http://www.springer.com/series/10019>

João M.P.Q. Delgado  
Editor

# Case Studies of Building Pathology in Cultural Heritage

 Springer

*Editor*  
João M.P.Q. Delgado  
Faculty of Engineering  
University of Porto  
Porto  
Portugal

ISSN 2194-9832                      ISSN 2194-9840 (electronic)  
Building Pathology and Rehabilitation  
ISBN 978-981-10-0638-8              ISBN 978-981-10-0639-5 (eBook)  
DOI 10.1007/978-981-10-0639-5

Library of Congress Control Number: 2016936650

© Springer Science+Business Media Singapore 2016

This work is subject to copyright. All rights are reserved by the Publisher, whether the whole or part of the material is concerned, specifically the rights of translation, reprinting, reuse of illustrations, recitation, broadcasting, reproduction on microfilms or in any other physical way, and transmission or information storage and retrieval, electronic adaptation, computer software, or by similar or dissimilar methodology now known or hereafter developed.

The use of general descriptive names, registered names, trademarks, service marks, etc. in this publication does not imply, even in the absence of a specific statement, that such names are exempt from the relevant protective laws and regulations and therefore free for general use.

The publisher, the authors and the editors are safe to assume that the advice and information in this book are believed to be true and accurate at the date of publication. Neither the publisher nor the authors or the editors give a warranty, express or implied, with respect to the material contained herein or for any errors or omissions that may have been made.

Printed on acid-free paper

This Springer imprint is published by Springer Nature  
The registered company is Springer Science+Business Media Singapore Pte Ltd.

# Preface

Rehabilitation is a strategic area that is concerned not only with the monumental heritage and historic buildings, but also with other buildings that have been in use for sometime and need to be adapted to the demands of the present. The following areas should also be considered: rehabilitation of the constructed heritage, hygrothermal performance of buildings and constructions, diagnostic and design methodologies, energy efficiency, effects of climate change, restoration of public spaces, rehabilitation technologies and analysis of case studies.

The main purpose of this book, *Case Studies of Building Pathology in Cultural Heritage*, is to provide a collection of recent research works, case studies of building pathology, to contribute to the systematization and dissemination of knowledge related to construction pathology, hygrothermal behaviour of buildings, durability and diagnostic techniques and, simultaneously, to show the most recent advances in this domain. It includes a set of new developments in the field of building pathology and rehabilitation, bridging the gap between current approaches to the surveying of buildings and the detailed study of defect diagnosis, prognosis and remediation. It features a number of case studies and a detailed set of references and further reading.

The book is divided into several chapters that intend to be a resume of the current state of knowledge for the benefit of professional colleagues, scientists, students, practitioners, lecturers and other interested parties to network. At the same time, these topics will encounter a variety of scientific and engineering disciplines, such as civil, materials and mechanical engineering.

João M.P.Q. Delgado

# Contents

<b>Evaluation of Constructive Pathological Manifestations in Public Buildings: The Olympic Stadium of Cascavel City, PR</b> . . . . .	1
Guilherme Perosso Alves and Ligia Eleodora Francovig Rachid	
<b>Pathology Analysis and Intervention at the Pavilhão Mourisco Roof Terraces—Rio de Janeiro, Brazil</b> . . . . .	21
Barbara Cortizo de Aguiar and Giovanna Ermida Martire	
<b>Overview of Damage to Medieval Rural Churches in Estonia</b> . . . . .	47
Paul Klõšeiko and Targo Kalamees	
<b>Finding Faults with Residential Buildings</b> . . . . .	69
Nigel Isaacs, Jim Bowler and Ethan Duff	
<b>Experience from Using Prefabricated Elements for Adding Insulation and Upgrading of External Façades</b> . . . . .	95
K. Mjörnell	
<b>Assessment of State-Supported Mould Renovations in Finland</b> . . . . .	115
Tero Marttila, Petri Annila, Paavo Kero and Jommi Suonketo	
<b>Recovery and Enhancement of Modern Architectures: The Case of Cinema Ariston in Potenza (Italy)</b> . . . . .	133
Antonella Guida, Ippolita Mecca and Silvia Michela Scavone	
<b>Plumbing System’s Pathologies Based on the Record of Technical Assistance and Design Procedures</b> . . . . .	163
Ruany Ferreira, Leticia Carvalho and Marcus André S. Campos	
<b>Cracks of Masonry Partition Walls in Multifloor Building: Case Study</b> . . . . .	183
A. Casado Lordsleem Jr.	

**Diagnosis and Seismic Analysis of the Our Lady of Conception Church, Portugal . . . . . 199**  
Nuno Mendes, Paulo B. Lourenço, Marianna Besca, Elisabetta Trufelli and Alberto Barontini

**Brutalist Architecture and Pathologies: How Design Mistakes Can Make a Building “Sick” from the Beginning . . . . . 221**  
Francesco Paolo R. Marino and Filiberto Lembo

**Basis of Stone Panel Pathology and Application of Infrared Thermography in the Pathology Study of Back-Ventilated Façades with Stone Panels. . . . . 233**  
C. Lerma, V. Blasco, Á. Mas, E. Gil and J. Vercher



# Evaluation of Constructive Pathological Manifestations in Public Buildings: The Olympic Stadium of Cascavel City, PR

Guilherme Perosso Alves and Ligia Eleodora Francovig Rachid

**Abstract** This study aimed to raise and identify existing pathological manifestations in the Regional Olympic Stadium Arnaldo Busatto of Cascavel city, PR. From these conditions located in different inspected levels, we sought to detect their probable causes to promote greater understanding of the causer mechanisms as much of their outcrops and evolution. The proposed method consisted on a survey data, which showed visible anomalies with subsequent appointment of causes of problems. It is possible to realize that the knowledge of the causes that induce appearing of symptoms coupled with awareness that providences of preparation of idealization steps, project, execution, and post-execution represent the reduction of a significant portion of the expenses in relation to recoveries. Regarding that the understanding of mechanisms of deterioration becomes central tool in the treatment of pathologies.

**Keywords** Case study · Pathologies · Probable causes · Maintenance

## 1 Introduction

According to Azeredo (1987), pathology is the segment of engineering that studies the causes, origins, and nature of failures that arise in a construction. After its manifestation, depending on its severity, the pathology can become in damage, which is the final result.

For Ripper et al. (1998), the pathology may be noticed as low or even failure of the structure performance regarding its stability, static, and durability.

---

G.P. Alves (✉)

Universidade Estadual de Maringá (UEM), Maringá, PR, Brazil  
e-mail: enguiperosso@gmail.com

L.E.F. Rachid

Faculdade Assis Gurgacz (FAG), Cascavel, PR, Brazil  
e-mail: ligia@fag.edu.br

These pathologies are evidences of the professionals' failures involved that can be found in all stages of the building, from the exchange of material specification during the execution period, failures in concreting, calculations mistakes, to even natural phenomena beyond human actions, such as the thermal dilation and shrinking or the natural aging of structures.

In recent years, the Brazilian society has encountered countless occurrences of constructive pathologies, reaching some situations of collapses, such as the partial collapse of Palace Building II, in Barra da Tijuca, Rio de Janeiro, which occurred in February 1998. An unfortunate episode in which the various project and execution errors of supporting structures may have been the cause of the partial collapse of the building, killing eight people. The construction company issued a statement ensuring the integrity of the rest of the building; however, twenty-two apartments collapsed a few days later. The simplest way to prevent accidents such as the case of the Palace II building would be through carrying out periodic inspections in buildings in order to ascertain their performance, pointing out flaws and providing subsidies for the solution that causes minor material and emotional losses to individuals involved.

Facts such as the collapse of the Palace building shows a major problem that haunts engineering professionals: The lack of knowledge of all involved, not only about the implementing techniques, but on the whole planning process of a project, which already starts in the idealization of the future property. Still, such problems demonstrate the importance of the technical areas being sufficiently qualified to foresee and offer continued and reasonable solutions to such situations.

For this, it is necessary to publish scientific work that contributes to the spread and growth of information in the area. Many of these episodes, for example, could be avoided with the existence of a standard that assists in the study of expert inspections. The lack of standards for the responsible professionals to develop assessments of degradation, by itself, makes it justifiable the interest on exploring the pathological conditions in buildings over their many origins.

Even well-designed structures, perfectly executed and used, can develop disease symptoms because every object is naturally exposed to wear due to the action of loads and overloads of the most varied kinds. Moreover, in many circumstances the built structures, for one reason or another, are exposed to not originally prevented requests, therefore, needing to have a larger bearing capacity. Another factor of broad interest is the using of the stadium facilities that ensure the well-being of those who use them, since improper treatment, or even the lack of treatment can result in destruction of the structure, endangering human lives.

The study and classification of apparent symptoms are also highly relevant in the process of awareness of public agencies about the importance of allocating resources to preserve such important building, which is a reference work, large sized and approximately 30 years old. Furthermore, builders, developers, and professionals from the engineering field need to be aware of the value of investment in the conservation and conception processes of its projects.

The lack of care allied to the lack of knowledge of construction methods axiomatically produce disqualification of labor, which can generate future anomalies, and more than that, certainly entail high costs, because the lack of understanding of the materials causes waste of the available resources.

The justification of studying the pathological manifestations in Cascavel Olympic Stadium leans, above all, on the need to disclose its most noticeable incidents defects. On the other hand, in a general way, it provides greater knowledge about the correct use, prevention, and maintenance of the buildings to the users.

Thus, the overall objective of this work is to raise the pathologies in Regional Olympic Stadium “Arnaldo Busatto” in Cascavel city, Paraná. This branches into four others as follows:

- Determine the types and frequency of pathologies found,
- Describe the mechanisms of deterioration,
- Point out the possible causes of visible symptoms, and
- Get a generalized view of the deteriorating Stadium through “cast-in-place” observation.

## 2 Building Inspections: Initial Concepts

IBAPE (2011) establishes the concept of building inspection as isolated or generalized assessment of technical conditions, usage, and maintenance of the building. This tool shows the authentic property situation, directing the maintenance actions and contributing to the preservation and development of heritage. The lack of this leads to the opposite situation. According to the same institute, the criteria used for the preparation of building inspections are based on the risk analysis, and this consists on classifying the pathological manifestations found in the various elements of a building over the urgency level related to conservation aspects, depreciation, health, safety, and systems’ functionality.

The complexity of the survey and the creation of its report, on the need of the number of professionals involved, and the observed gravity are defined by the inspection levels (IBAPE 2011).

### 2.1 Inspection Levels

IBAPE (2011) classifies and defines the inspection levels and their definitions as follows:

- First level: It is carried out the survey, identification, and quantification only of the visible symptoms and diseases, and it must be developed by a qualified professional on site. This study was limited to this level;

- Second level: It is necessary to survey for the identification of pathological manifestations and apparent defects by identifying them with the help of special equipment and devices, as well as analyzing the specific technical documents, considering the complexity of existing construction systems. The inspection of the building at this level is made by professionals qualified in one or more specialties, because this level involves a wider range of knowledge;
- Third level: This level is equivalent to the parameters listed for inspections of the second level added of combined or isolated technical auditing of technical aspects, of using or maintenance performed in the building, as well as guidelines aiming to the improvements and adjustments of existing procedures in the maintenance plan. This level of inspection requires multidisciplinary knowledge on even larger scales.

### **Degrees of Risk**

According to IBAPE (2011), the degrees of risk of pathologies in a building inspection are defined as follows:

- Critical: The pathologies can cause damage to the health and safety of users and/or the environment, as well as excessive loss of performance, which can lead to possible shutdowns, increased cost, sensitive commitment to useful life, and the depreciation of the project. Cracks and excessive deflection can be signs of this degree of abnormality;
- Regular: The anomalies may lead to loss of functionality without necessarily undermining the direct operation of systems; there can be also minor losses of performance, which means that there are possible recovery forms; and in addition, there may be small devaluation of the building. As an example, we can mention the deformations that do not compromise the stability of slabs, beams, and columns;
- Minimum: It causes small losses only to aesthetics without compromising the stability of the building, can cause low or no devaluation of the property. The efflorescence in building facades can be framed in this parameter.

## ***2.2 Advantages and Disadvantages of Visual Inspection***

Watt (1999) highlights the following disadvantages in the visual assessment:

- By owning subjectivity, visual inspection makes room for variation of trial of who carries out and the evaluation results are subject to vulnerability;
- Only visual observation is not enough to detect problems at an early or latent stage.

To overcome, the first disadvantage is necessary to distinguish the risk levels of each pathological problem. The second observation is even more important; thus, not always the pathological problem provides visible indications and is understood to be latent and may result in secondary damage. The problem is even greater that much of the defect only becomes visible at later stages of deterioration and has its aggravation evolved dramatically. This means higher expenditure of time, resources, and professionals focused on the development of restoration measures to acceptable levels. These expenses could be reduced if the abnormalities were detected earlier. In this sense, preventive maintenance becomes an important tool in monitoring the conditions of a building.

In contrast, the main advantages of the visual observation are its simplicity and its connection with the strategic maintenance. From an operational standpoint, the visual evaluation becomes interesting by not requiring additional activities such as the isolation of dependencies.

### **3 Limits of Research—Object of Study**

In general, the Regional Olympic Stadium “Arnaldo Busatto” consists of reinforced concrete structure, in ellipsoidal shape, which contains the locations of accommodation, such as chairs, bleachers, booths and press rooms, gyms, and locker rooms to the public, press, and players. From many of these accommodations, it is possible to view the central lawn.

We can mention among the main structural elements of the Stadium the “giants” that support the various elements of the reinforced concrete structure, the paths of access (of quotas 4.3 and 4.5 m), the inclined slabs of bleachers and chairs, and the metallic awning as coverage. Other important structural elements of the building are the slender beams with rounded ends that support the sloping slabs of bleachers and chairs.

In relation to the original building, after its inauguration on November 10, 1982, the preventive maintenance services were not made of methodical and judicious manner. There are no official records of maintenance on the stadium; the only modification made after the inauguration was to exchange all the ceramic tiles of the bathrooms located on level 2 as well as the replacement of sanitary ware and accessories. Moreover, public building has been exposed to atmospheric aggressive agents, weathering, and pollution, through natural forces such as humidity, rainfall on its surface, and through waste gases from vehicle engines. The stadium was and still is the target of acts of vandalism, such as depredation of sanitary ware and accessories, fixtures withdrawal, aggression by organic fluids such as urine and clogging drainage pipes by garbage. These events result the occurrence of wear of the building (Fig. 1).



**Fig. 1** Olympic stadium Arnaldo Busatto

## **4 Materials and Methods**

The present research was developed based on a case study, considering the detection of some pathological symptoms in Regional Olympic Stadium “Arnaldo Busatto” in Cascavel city, Paraná, maintained by the public administration. In order to investigate and describe the existing pathological manifestations, as well as identifying their probable causes. The survey was made in a quantitative manner, as it sought, through “cast-in-place” observation, point the incidence of pathologies found. To this end, the research was divided into steps.

### ***4.1 First Step: Bibliographical Research***

The bibliographical survey consisted in the study of theoretical basis in order to facilitate understanding about pathology and the importance of its study by means of sources such as articles, theses, monographs, dissertations, books, manuals, electronic media, and other sources that provided the foundation for the development and maintenance of the topic.

### ***4.2 Second Step: Data Collection***

The first path was indicated by Silva (2007) in his script work, since prioritizing the step of specific tests demands a greater period of time and in view of the lack of documentation of the enterprise.

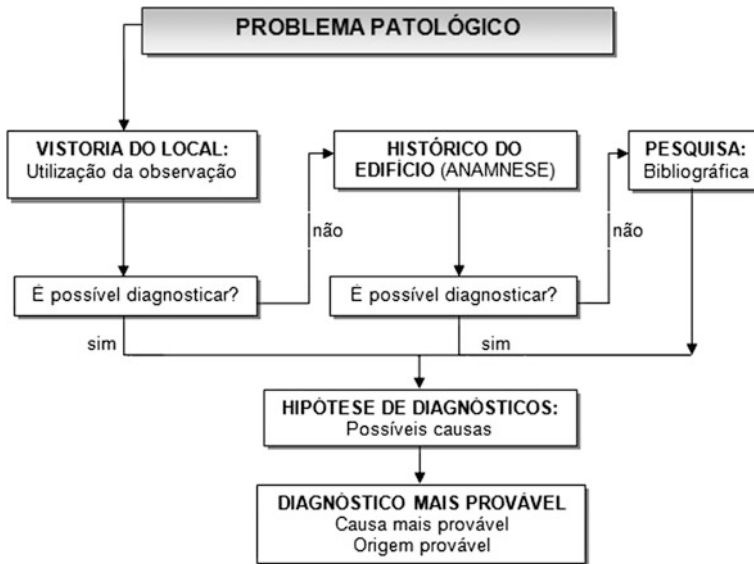


Fig. 2 Schema of method used

Figure 2 shows the schema adopted in this work, based on the Silva’s model (2007), which was limited to data collection and observation of possible diagnoses. For data collection, visits at Olympic Stadium were established, with photographic recording and mapping the pathological manifestations found.

Magalhães (2004) states that data collection in pathological surveys should be systematic, given the intensity and the incidence of pathological problems. In data collection were established visits to the Olympic Stadium, with photographic record and mapping the pathological manifestations found. The accounting of pathologies was performed using a checklist as support material, to identify and locate the apparent anomalies and displayed them in sketches. The spreadsheets used in data collection, Fig. 3, show the dates of the inspection, the name of the building, its address and year of construction as well as time of use, the number of floors, and the number of leaf identification. During the surveys, the start and end of data collection were recorded, as well as temperature, relative humidity, the direction, and intensity of winds. This information was incorporated into the “observations” of spreadsheets

### 4.3 Photographic Record

The photographic record, incorporated to accounting process of anomalies, became a fundamental tool in the identification and mapping of pathologies found. The data obtained during the data collection were organized and identified from

SURVEY SHEET OF THE PLACE (Jan 21, 2013)				
NAME OF BUILDING		ADDRESS		
REGIONAL OLYMPIC STADIUM ARNALDO BUSATTO		300, TITO MUFFATO AV. - CASCAVEL/PR		
YEAR OF THE BUILDING	USAGE TIME	N° OF FLOORS	LEVEL	SHEET N°
1982	32 YEARS	3	1	1
PHOTO	PLACE	PATHOLOGY	WALL/ SLAB	COMMENTS
1	Bar/Snacks	Detachment of ceramic coating	PB	The causes can be maintenance or execution because of the lack of substrate cleaning or irregular attachment
2	Bar/Snacks	Fissure	PC	Compressive loads transferring (vertical)
3	PBAX	Fissure	PB	Diagonal fissure
4	Bar/Snacks	Fissure	PA	Between beam and wall
5	Bar/Snacks	Fissure	PC	Fissura diagonal pela massa de assentamento
6	Bar/Snacks	Infiltration	ROOF	Humidity stain in slab
COMMENTS:				
PA - NORTH WALL		PB - EAST WALL	PC - SOUTH WALL	PD - WEST WALL
Thursday, 10:00 a.m., 30°C. Wind direction: NNE				
Condition: A few clouds				
Humidity: 61%				
Wind speed: 19 km/h				

Fig. 3 Checklist worksheet used in inspection

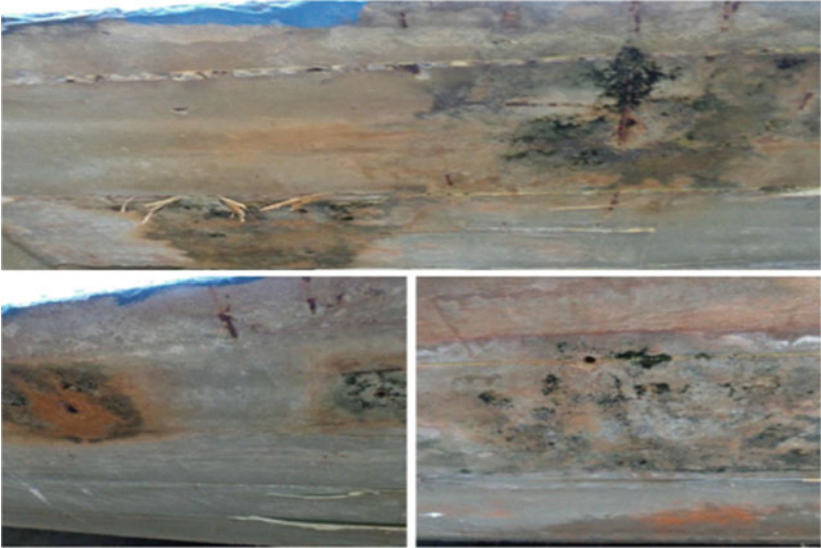
photographic records, as well as incorporated into the sketch, to indicate the location of the problems and to obtain the generic Stadium framework. Next, in Fig. 4, the model of records of the images, captured in each inspection, with the most relevant pathological manifestations for the study.

For the correct location of the pathological manifestations during the inspections in the building, we used the checklist worksheet and sketches. These sketches contained the dates of the surveys, property name, the address, the total building area, the area of land, the building location on the propriety, and the northern indication. To standardize inspections and provide better understanding of its current conditions, it was decided to separate the stadium on four levels, thus the building was divided into four levels as follows:

- Level 1—lower floor;
- Level 2—the eight public toilets, eight bars, a police station and a clinic, bleachers, and covered area;
- Level 3—last floor including press booths; and
- Level 4 (external area)—includes parking, water tank, and external facades.

The data analysis was based on previous steps; thus, pathologies found were registered based on bibliographical references and subsequently verified the



PHOTOGRAPHIC RECORD		
		
TECHNICAL DATA		
SOURCE: FIELD RESEARCH PERFORMED BY THE AUTHOR		Location - Circulation 04      jan/14
Pathology type	Mold	
Symptom data	There are holes in the slab. At some points it is possible to note the coating detachment, oxidation of the slab reinforcement and deployment of pieces of wood.	
<b>Probable causes</b>	Ineffective waterproofing of the slab	
	Infiltration of rainwater	
Degree of risk	Regular	

**Fig. 4** Example of photographic registration form used

probable causes of the symptoms that affect the stadium and incorporated into records of the photographs, specifying the degree of risk to which the building and its systems and subsystems are submitted.

The classification of all pathological manifestations was performed taking into account their presence, degree of risk indicated by the author and extension of the injured area.

From the data collected in the Olympic Stadium, graphs that show the incidence of manifestations by type of symptoms found, probable causes, orientation of fissures, and the risk degree were developed. Percentages were obtained by subdivision of the total quantity of manifestation by corresponding value to each classification present in the graphs (Fig. 5).

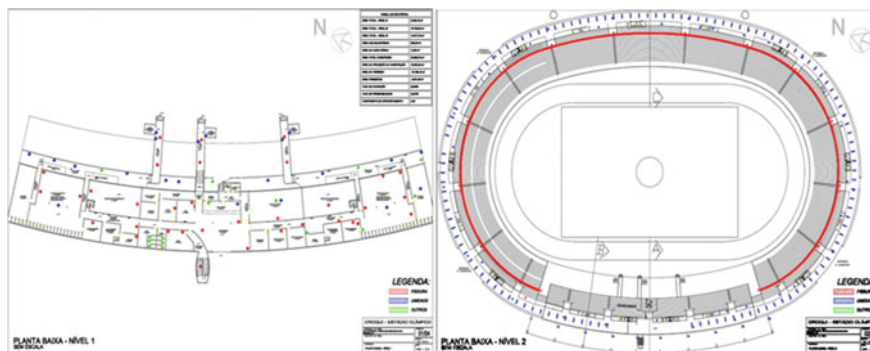


Fig. 5 Mapping of pathologies in the different levels of the stadium

## 5 Results

### 5.1 Level 01

Through field visits, it was found various manifestations located at various points in the building. The first level in general presents few pathologies, which are more frequent between beams and walls as cracks, merely aesthetic and the majority with minimum risk level. In slabs, it is possible to note the presence of certain stains and some detachments of mortar coating and linings, probably by water infiltration through joints and openings in these elements. Other events that could contribute to significantly reduce the lifetime of the structures were not found.

From the survey of the anomalies and their positioning in the sketch environments, the stadium could be started pointing the possible causes of such manifestations. For this, the record models for the figures were filled.

In Fig. 6, it is possible to check the exposure and oxidation of the slab reinforcement in some isolated spots throughout the length of the slab of circulation 04, which may indicate a lack of prompt spacers; non-compliance of coverage requested in project or project error because of the lack of it; high porosity and permeability of the concrete, which provides accelerated corrosion processes of reinforcement; scape of cement fine layer in wooden mold process because of the lack of locking or inadequate vibrating of concrete, since it is remarkable accumulation of aggregates in some areas, also associated with the deformation process, as some plywood fragments can be seen near the areas of concrete detachment. Here, the risk degree is understood as regular, because the stained points of oxidation suggest specific performance losses. However, only visual observation does not indicate whether the loss of bars due to oxidation is greater than 10 % of the gauges of the bars, characterizing considerable loss of resistance and, in this case, it would take the structure to critical levels of the commitment of structure.

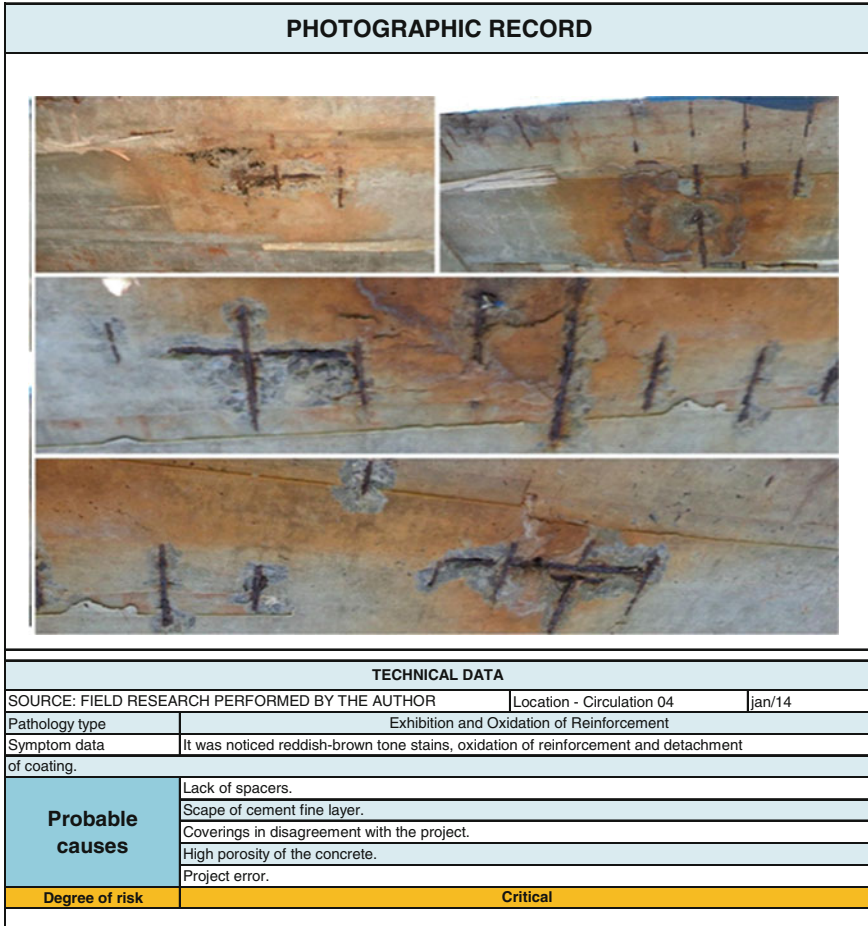


Fig. 6 Oxidation of slabs

Therefore, we highlight the importance of using spacers to promote minimum coverings to armor in concrete structures to guarantee protection to internal elements of the stadium structural elements. The minimum covering in concrete elements, as well as its dimensions, factor water/cement, and among others are elements of great responsibility on the durability of concrete structures, providing physical and chemical protection of armors, involving them in an alkaline medium. The covering must be specified in the structural designs and its value depends on the environment aggressiveness class. (NBR 6118 2014).

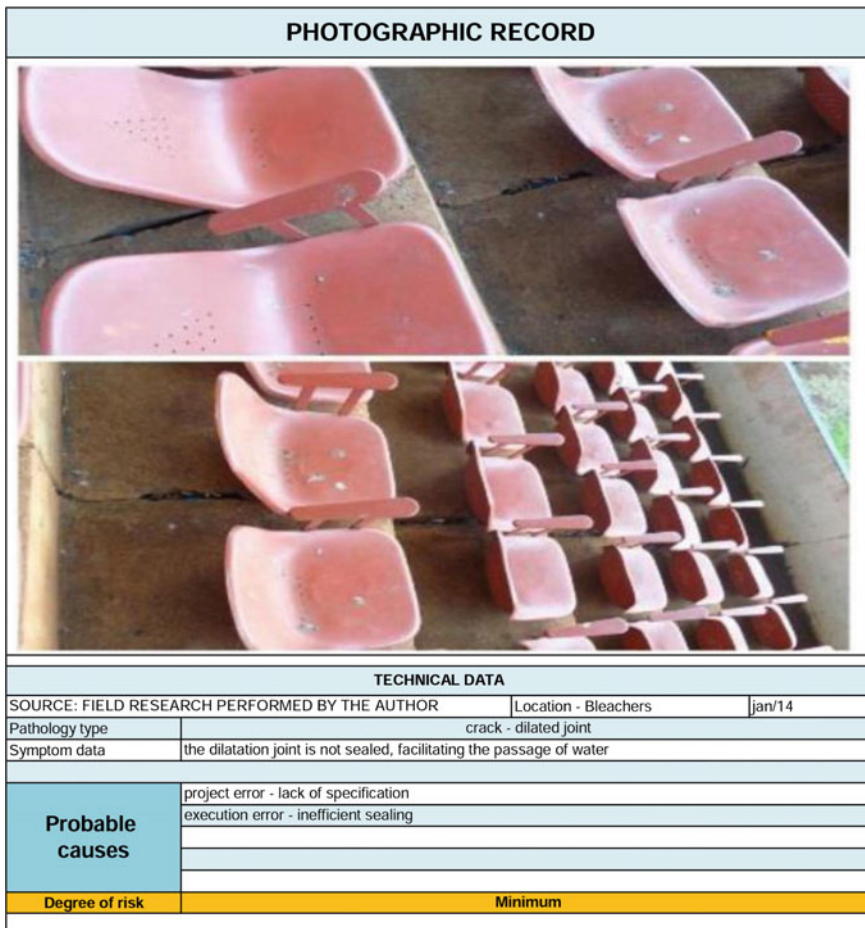


Fig. 7 Opening joints on bleachers

### 5.2 Level 02

At this level, 124 inclined pillars in the outside circulation of public access that support the inclined slabs of bleachers were conferred. In all of them, it was possible to determine the presence of humidity stains, alive microorganisms such as green fungi, and dilated joints (Fig. 7).

It is shown in Fig. 6 the appearance of small isolated areas with exposed armor in the corrosion process due to the low thickness coatings. The vertical expansion joints of the slabs from the stands were not properly sealed, which explains many of the infiltrations found in the previous level, being observed in various points of reddish-brown stains that suggest corrosive process of armor in isolated areas and

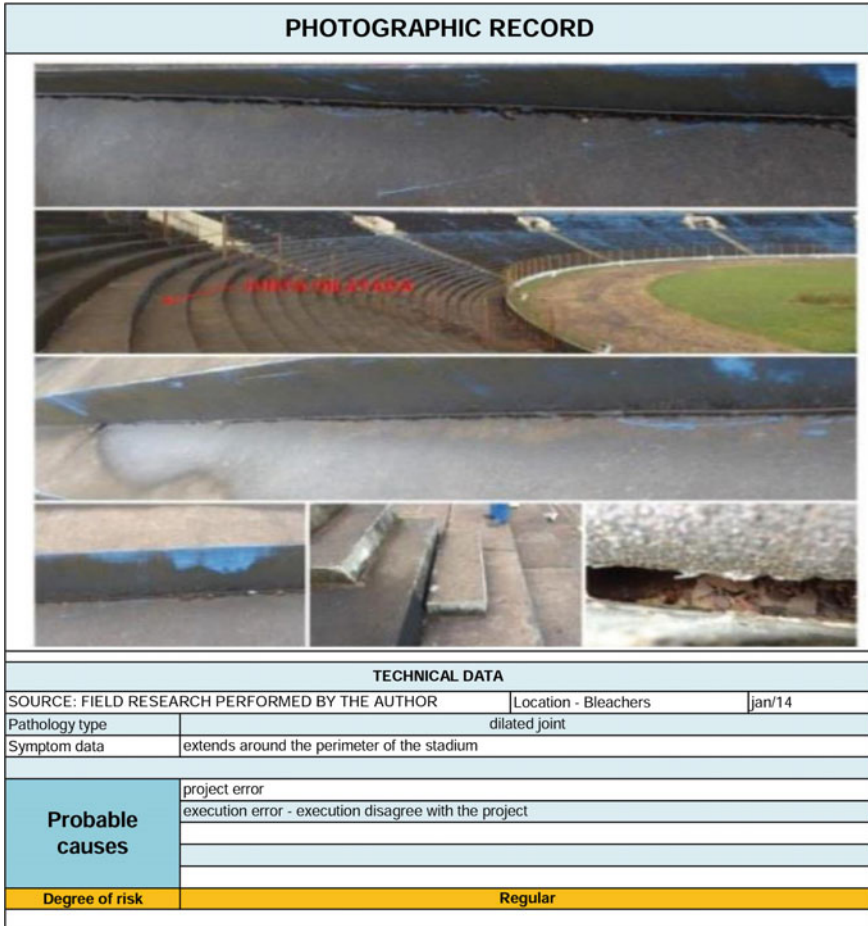
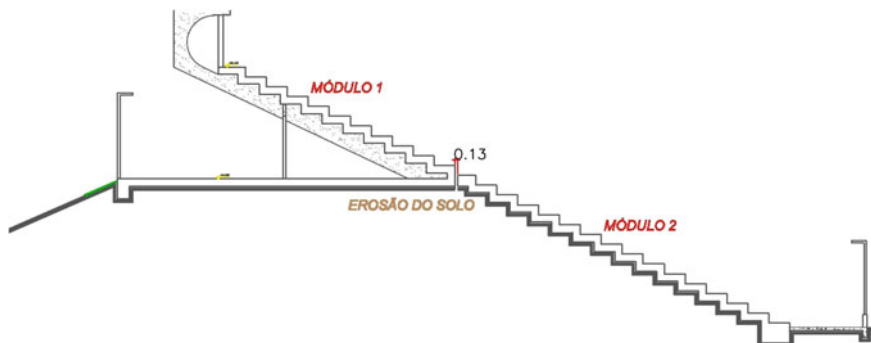


Fig. 8 Dilation of horizontal joint

the presence of black spots caused by live microorganisms throughout the length of the bleachers (Fig. 8).

Separation of expansion joints, shown in Fig. 6, was possibly originated in the phases of project or execution, because of the lack of details and specifications in project or non-compliance of such details and specifications, since this pathology is not preventable by maintenance operations. This horizontal slit is located at the point where the inclined slab of the bleacher ceases to be grounded and shall be above ground level, so the lower and upper module slabs module work with different coefficients of movement, expansion, and retraction, which led to the emergence and enlargement of dilated joint. The importance of this pathology goes beyond the separation between modules of the bleachers; it is in its extension that covers the whole discovery area of the stadium bleachers and, through these, other



**Fig. 9** Cross section of the bleachers slab

secondary pathologies are originated as infiltration points; separation of ceramic plates in all bars accompanied the accommodation of modules of the bleachers beyond the erosion of the portion of soil that is under the joint. It is possible to realize, in many places under the bleachers there are brown stains that suggest the displacement of soil with erosion.

Another important feature is the width of joint separation that in the opposite point to covered area reaches values up to 13 cm between modules (Fig. 9).

Freedom of movement, regardless of the reason, it is essential to guarantee the physical integrity of the structure; otherwise, as here, tensions that arise force structures to separate.

### 5.3 *Level 03*

This level covers the press boxes located on the top floor of the stadium; here, the pathologies found as in previous levels, showed no risk to the health and safety of users.

Many factors may have allowed the emergence of the situation shown in Fig. 10, one of them is the expansion joint that was not defined on their entire length, which resulted in coating detachment in certain points, exposing reinforcement bars of the elements reinforced concrete through the natural movement of the materials. The dilatation joint, as its name suggests, is designed to ensure freedom of movement of the elements due to temperature variations that cause contraction and dilation movements and certain accommodation of the foundation elements, but you can see that some steel bars are joining a pillar to another, working as points of rigid connection and aiding in the coating detachment process and consequently on exposure and oxidation own rods. It is possible to note that the dilatation joint and drive is not properly sealed, which explains points of moisture stains.


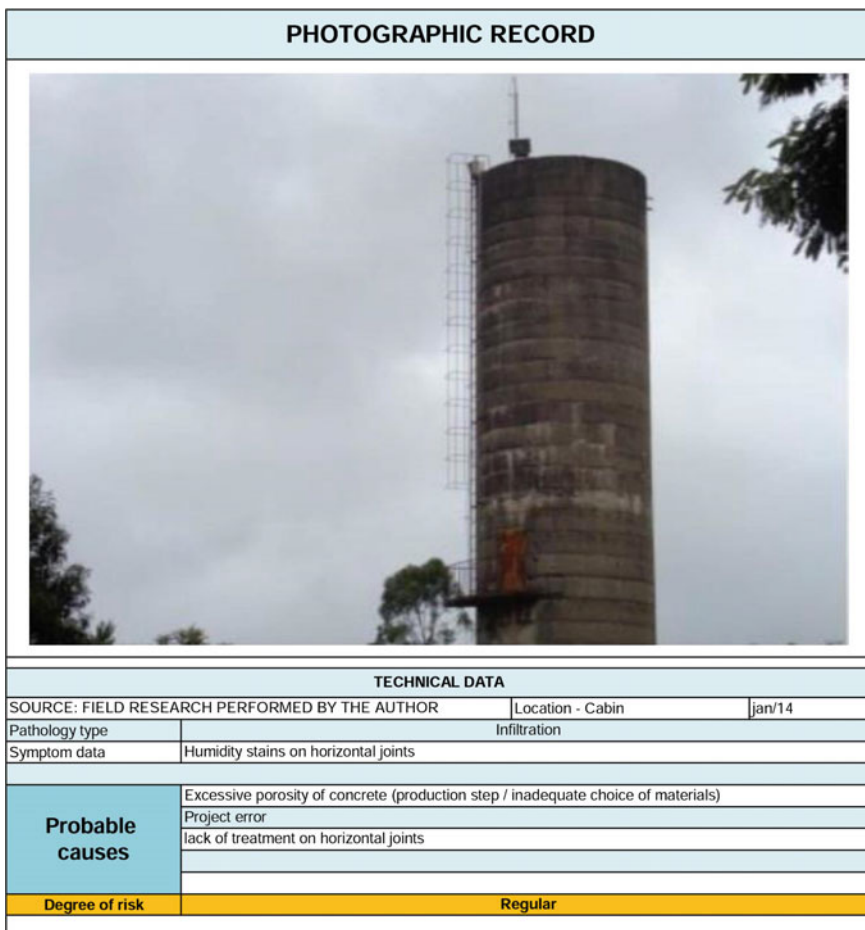
PHOTOGRAPHIC RECORD		
		
TECHNICAL DATA		
SOURCE: FIELD RESEARCH PERFORMED BY THE AUTHOR		Location - Cabin   jan/14
Pathology type	crack, detachment, armor exhibition	
Symptom data	detachment of coating and oxidation armor in the dilatation joint	
<b>Probable causes</b>	oxidation due to insufficient coverings - project or execution error	
	moving of the joint caused detachment	
<b>Degree of risk</b>	<b>Regular</b>	

Fig. 10 Cracking and coating detachment

### 5.4 Level 04

Attentive to the fact that certain pathologies this level appear disseminated for much of the external facade of the stadium in large areas, it is not possible to record them on time, but, mapping the damaged region. Therefore, the accounting of anomalies did not consider the extent of the damage, but the appearance on the observed location. In the reservoir shown in Fig. 11 realizes the presence of infiltration stains in concreting joints associated with small cracks accompanying the joints. The causes of this damage may be related to the absence of treatment of concreting joints, with treatment executed improperly or insufficient. This inadequacy of joints promoted the emergence of cracks along the perimeter of the joints, which enable the passage of the water stored to the external environment. The white



**Fig. 11** Infiltration and carbonation

patches on the concrete surface indicate carbonation process. Carbonation starts with the formation of carbonic gas that reacts in contact with the calcium hydroxide which was formed in the cement hydration step. Calcium hydroxide migrates to the surface by water pressure forming calcium carbonate deposits.

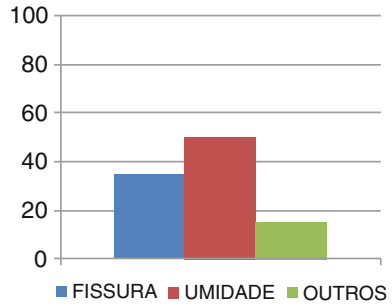
The biggest point of this manifestation is that the calcium hydroxide is responsible for protecting reinforcement in reinforced concrete, involving them in an alkaline environment. This process tends to increase the porosity of the concrete, which may result in oxidation of armor.

The graphs obtained from data collection are as follows.

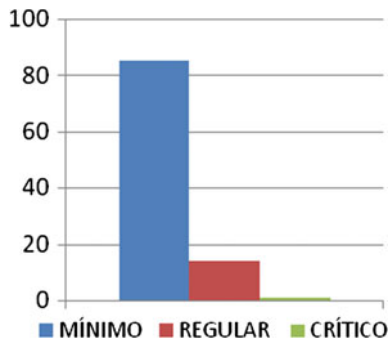
The graph in Fig. 12 shows that most of pathologies that are incident in all levels of the stadium are caused by humidity, followed by fissures and, finally, other pathological manifestations, such as floor settlements and detachment of mortar



**Fig. 12** Types of pathological manifestations found



**Fig. 13** Pathologies by degree of risk

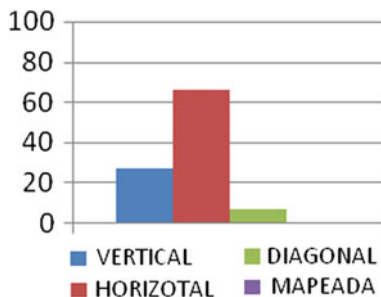


coatings, breaking of ceramic coatings, and detachment of paintings. Such amounts may be related to the exposure of the elements present on the second level to the weather and correlated to possible insufficient waterproofing processes or lack of maintenance of these. In contrast, the third level is where the constructive elements are in lower exposure to weathering external agents causing constructive diseases and, unlike the level 1, does not maintain contact with the ground and possible rise episodes of humidity from this material body.

The graph shown in Fig. 13 represents the quantity of pathologies depending on the risks they represent. The truth is that because it is about a visual inspection, the classification of different degrees of risk is strongly influenced by subjectivity. In this study, the degree of risk was classified taking into account the extension and location of damages, being critical the ones present in the elements with bearing loads and that can contribute in their loss of performance, regular the ones that contain small deformations and minimum the point defects showing losses only in aesthetic parts. It is found that the largest part of pathologies, approximately 85 %, is anomalies that cause aesthetic damages. This value reiterates the importance of scheduled preventive maintenance operations. In contrast, 1 % of the pathologies frame within the critical level, these pathologies are, generally, in the form of reinforcement oxidation in elements of reinforced concrete.

The cracks in the walls were classified according to their direction, being classified as follows: diagonal, vertical, horizontal, and mapped. They are shown in

**Fig. 14** Direction of the cracks



**Fig. 15** Origin of pathological manifestations

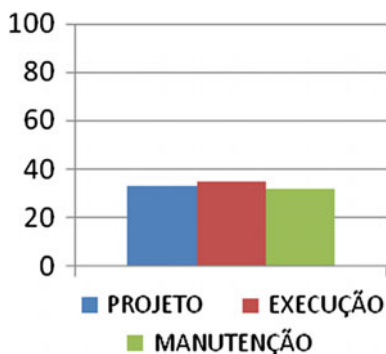
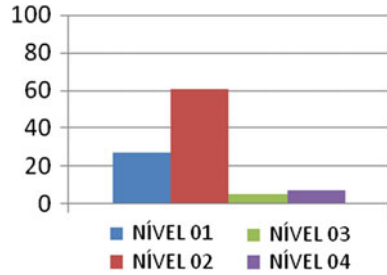


Fig. 14, which in all four evaluated levels stand out the horizontally directed pathologies that may represent inharmonious movement, either by shrinkage and thermal expansion between the ceramic material components walls and concrete structures, or by humidity; as well as the possibility of failure or prematurity of the wedge-shaping procedures perceived in some environments inspected at the first level.

At levels, in general, the definition of the origins of pathological symptoms, shown in Fig. 15, appears to have in each of the main steps of the constructive cycle, approximate values of average between 33 and 35 %. The survey presented points failures of projects, execution, and maintenance as pathological responsible agents of great relevance. It is possible to view some balance in the quantity of anomalies arising in each of these steps, which shows, especially in the case of the Olympic Stadium, that problems related to projects still keep being one of the significant causes in conduction of studies focused on pathology, but the question of maintenance quality becomes as significant as the project and execution internships.

Figure 16 shows the incidence of pathological manifestations by level inspected. Of the total existing walls at the stadium, nearly 62 % had some kind of visible pathological manifestation. Approximately 48 % of existing slabs had some types of degradation. This level is the holder of the largest number of pathologies found. Such amounts may be related to the exposure of the second level elements to

**Fig. 16** Pathologies per level



weathering agents and possibly related to insufficient waterproofing processes or lack of maintenance of these. In contrast, the third level is where the building elements have a lower exposure to external agents of weathering causing constructive diseases and, contrary to the level 1, does not maintain direct contact with the ground and possible episodes of moisture ascending from this material body.

## 6 Final Considerations

It is possible to conclude that the pathologies do not represent, in most cases, risks to immediate safety to their benefited users. The emergence of symptoms mentioned has several starting points caused in all phases of the constructive cycle of the building.

Aspects regarding the construction were mainly related to the deficiency or absence of execution of waterproofing techniques.

It was found frequent failures related to the lack of projects, deficiencies in construction methods chosen, and among others that directly interfere in the onset of symptoms. In addition to the carelessness of users and managers on the need for periodic preventive operations accompanied by a qualified professional.

It was noticed that on days when the winds are at lower speeds associated with high relative humidity, generally around 80 %, the symptoms become more evident and, in some cases, as in infiltration stains, has its extension enlarged. In this sense, Cascavel’s climate changes can be understood as contributing factors to the acceleration of the deterioration of some elements. In some elements, mostly on the second level, it is necessary to pay attention to excessive exposure to water.

It is also necessary do reiterate the fact that, no matter how simple the visual inspection procedure is, it can provide much information about the buildings conservation. Thus, we want to demonstrate the need for planning of preventive inspections of public buildings in general, especially in the Olympic Regional Arnaldo Busatto Stadium; for the simplicity of these inspections and their importance to detect and treat the constructive pathologies, because in most cases, when there are problems, the symptoms are visible and easily understood.

## References

- Associação Brasileira de Normas Técnicas (2014) NBR 6118: Projeto de estruturas de concreto
- Azeredo HA (1987) O edifício e seu acabamento. 1. Ed. São Paulo: LTC—E. Blücher, p 178
- Gomide, FAGUNDES NETO JCP, GULLO MA (2009) Engenharia diagnóstica em edificações. São Paulo: PINI
- Instituto Brasileiro de Avaliações E Perícias–IBAPE (2011) Norma de inspeção predial. p 33
- Magalhães AC (2004) Patologia de rebocos antigos. Lisboa: LNEC, Outubro de. (Cadernos de Edifícios, 2)
- Ripper T, Moreira de Souza VC (1998) Patologia, recuperação e reforço de estruturas de concreto. São Paulo, Pini
- Silva N, Ferreira AM, Pazzini LS, Abrantes Luis A (2007) Abordagem Determinística e de Simulação de Risco como Instrumentos de Análise de Viabilidade Financeira em Investimentos Imobiliários. Revista de Negócios da FURB, Blumenau, 12(3):3–17
- Watt D (1999) Building pathology, principles and practice. [S.l.]: Blackwell science

# Pathology Analysis and Intervention at the Pavilhão Mourisco Roof Terraces—Rio de Janeiro, Brazil

Barbara Cortizo de Aguiar and Giovanna Ermida Martire

**Abstract** The Pavilhão Mourisco, designed in Moorish revival, is the icon of Fundação Oswaldo Cruz. Listed in 1981 as National Heritage, the building nowadays holds the foundation's historical collections and makes room for some administrative personnel. The building is subject to severe wind conditions, acid rain and pollution, which all accelerate the deterioration rate of the building's external elements. The Department of Historical Heritage at Fundação Oswaldo Cruz has been developing emergency actions for safeguarding the building, but rainwater infiltration is a recurring issue. In order to develop an accurate plan to reverse this hazard, an analysis of the pathologies in place and of the department archives had to be carried out, as well the testing of the previous waterproofing solutions for that area. After that, the department developed a restoration project in order to restore the waterproofing system for the terraces, involving work on the external elements including decorative mortars, ceramic tiles and copper drip edges. The last physical intervention had the objective of stopping the deterioration processes and their consequences in order to preserve the building and the institution's collections.

**Keywords** Case study · Cultural heritage · Pathology analysis · Waterproofing · Mortar · Fiocruz

## 1 Public Health and Architectonic Preservation

The Instituto Soroterápico Federal (Brazilian Federal Serotherapy Institute), now known as Fundação Oswaldo Cruz (Fiocruz), was founded in 1900 with the goal of producing serums and vaccines against the bubonic plague, also known as the black

---

B.C. de Aguiar (✉) · G.E. Martire  
Fundação Oswaldo Cruz, Casa de Oswaldo Cruz, Rio de Janeiro, Brazil  
e-mail: barbaracortizo@fiocruz.br

G.E. Martire  
e-mail: gem@fiocruz.br

plague, and other diseases that afflicted many inhabitants at the time. After the designation of Oswaldo Cruz as director, in 1902, the Institute expanded its activities and became involved in research and experimental medicine.

Oswaldo Cruz (1872–1917), physician, bacteriologist and epidemiologist, is renowned for his position as Public Health Officer and founder of the Oswaldo Cruz Institute. He studied Medicine in Rio de Janeiro and went to Paris to specialize in bacteriology at the Pasteur Institute,<sup>1</sup> in 1896. Upon returning to Brazil, Cruz engaged in the combat of the bubonic plague and was soon appointed as general director of the Instituto Soroterápico Federal. He started a series of sanitation campaigns, using the Institute as technical–scientific base, and battled yellow fever and smallpox.

Fundação Oswaldo Cruz is a scientific institution for research and development in biomedical sciences. Fiocruz was not confined to Rio de Janeiro, where its main campus is located,<sup>2</sup> and collaborated in the occupation of the Brazilian countryside through scientific and sanitary expeditions. Today, the institution has a broad range of responsibilities towards the health and well-being of the Brazilian population. Fiocruz contributes to improving health mainly through its support to the Sistema Único de Saúde (National Health System<sup>3</sup>), its proposals on public health policy-making, its research activities, its scientific expeditions and the reach of its health services and products.

In spite of being an institution dedicated to scientific and health care research, Fiocruz has a unit—the Casa de Oswaldo Cruz—that focuses on its history, memory and cultural heritage. It is the Fiocruz technical and scientific unit responsible for the preservation of the foundation’s memory, as well as for researching, teaching, documenting and divulging public health and biomedical sciences History in Brazil.

At the institution's historic site, the visitor will find important architectural specimens listed as Brazilian national heritage, with large urban and landscape potential. The preservation of this heritage is the responsibility, since 1989, of the personnel<sup>4</sup> from the Department of Historical Heritage (DPH) at Casa de Oswaldo Cruz. Since it was established, the department has been developing emergency actions, intervention plans and restoration projects regarding the buildings and their collections’ safety and integrity.

---

<sup>1</sup>Named after Louis Pasteur (1822–1895), French chemist and microbiologist, renowned for his discoveries of the principles of vaccination.

<sup>2</sup>Fiocruz has offices in Rio de Janeiro, in five other Brazilian capitals (Belo Horizonte, Salvador, Recife, Manaus, and Curitiba), and in Maputo, Mozambique’s capital.

<sup>3</sup>The Brazilian public health system.

<sup>4</sup>Architects, historians, conservators, and engineers.

## 2 The Moorish Pavilion at Fundação Oswaldo Cruz

One of Fiocruz's historic buildings is the Pavilhão Mourisco, designed in Moorish revival style and built from 1905 to 1918. The building is the icon and part of the Pasteur Square, along with other three buildings<sup>5</sup>. This ensemble made up a space for scientific research and vaccines and serums production, in the beginning of the activities of the Instituto Soroterápico Federal. Pavilhão Mourisco now holds the Foundation's historical collections and makes room for some administrative personnel and the Foundation's Presidency (Fig. 1).

Luiz Moraes Jr. designed the Pavilhão Mourisco as a request from Oswaldo Cruz, to house the Chemistry and Physics laboratories of the Oswaldo Cruz Institute, one Library, the Museum of Pathologic Anatomy and some dormitories and workshop rooms. A sketch by Oswaldo Cruz of a two-storey, two-towered building was a starting point for the architect. The neo-Moorish style of the building follows that of the Alhambra<sup>6</sup> in Granada, south of Spain, and of the Meteorological Observatory of Montouris, in Paris—which Cruz visited during his studies at the Pasteur Institute.

Eclectic by its nature, the building combines two or more styles and decoration tendencies and is one of the few neo-Moorish buildings still standing in Rio de Janeiro. It was designed following English and Portuguese influences, such as the “H”-shaped plan with a vast staircase in the main hall, and a separate structure for the bathrooms. The ornamentation in Moorish patterns follows the fashion in Europe with the medieval revival movements. In this case, it brings out the architecture as art, through a romantic point of view—bringing an aura of magic to the “Palace of Science”, as Oswaldo Cruz intended to call the pavilion (Figs. 2, 3, and 4).

Most of the materials used in the construction were brought in from Europe, as well as the (Portuguese, Spanish and Italian) specialised workers. Sand and stone were extracted from the former Instituto Soroterápico Federal site, and the wood came from local shops (Fig. 5).

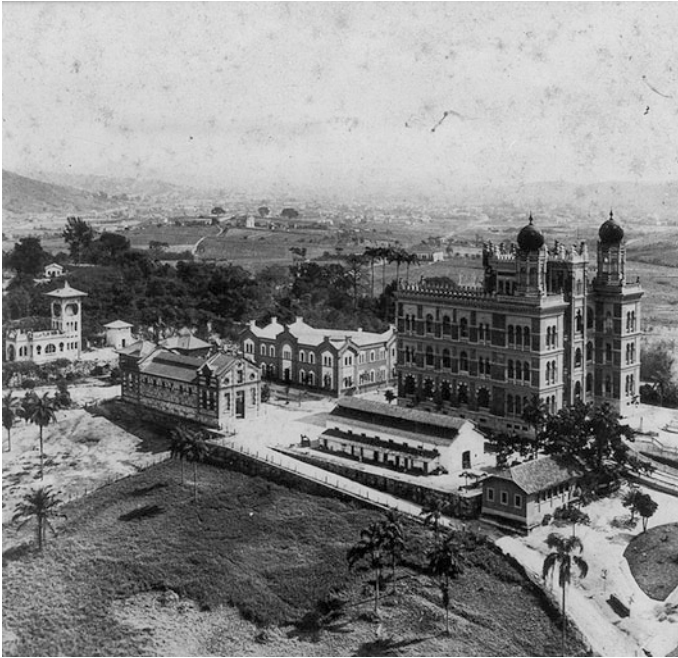
The ceramic materials, such as bricks and roofing and flooring tiles, came from Marseille, France, and the light fixtures, the steel for the structure and ironclad windows and staircases, from Germany. The cement and the white Villeroy-Bosch ceramic tiles, for the laboratories, came from England. The marble is Italian, and the decorative tiles are Portuguese, by Bordallo Pinheiro (Benchimol 1990).

The building had the most modern equipment of its time, such as an elevator, telephone, heating, and gas systems for the laboratories and a clock system for the entire building. The ground floor of the pavilion housed all of its laboratory

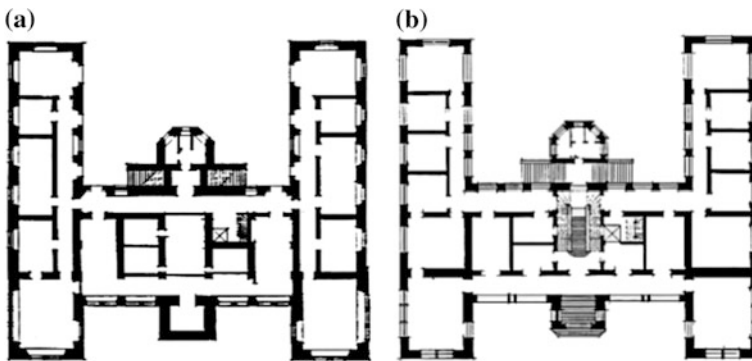
---

<sup>5</sup>Pavilhão para Estudo da Peste (also known as Clock Pavilion, 1904–1905), Cavalariça (the Mews, 1904–1905), and the Pavilhão Quinino (for the production of the Quinine, 1919–1921).

<sup>6</sup>Built between 1238 and 1492, served as a palace, citadel, and fortress.



**Fig. 1** View from the Instituto Oswaldo Cruz in the early 1920s (All images belong to the Casa de Oswaldo Cruz archives.)



**Fig. 2** Pavilhão Mourisco’s ground-level (a) and first-floor (b) plans, respectively

infrastructure. In its rooms, one could find a frigorific chamber, a gas compression machine, centrifuges and electrical mixers, and shredders, for example (Fig. 6).

As the lines of the “Light and Power Company” were not installed in the region until the 1920s, all the electrical appliances from the Instituto Soroterápico Federal



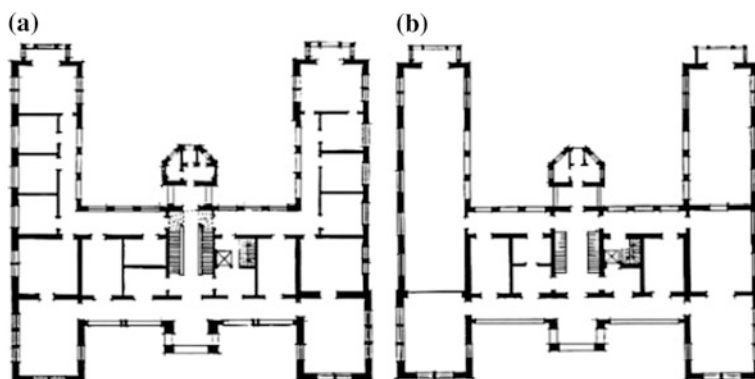


Fig. 3 Pavilhão Mourisco's second-floor (a) and third-floor (b) plans, respectively

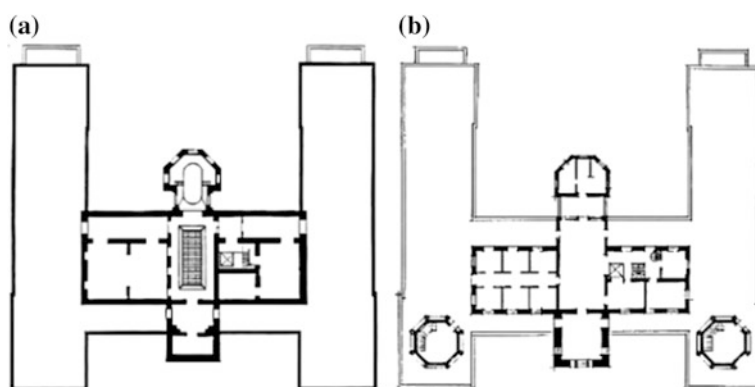


Fig. 4 Pavilhão Mourisco's fourth-floor (a) and fifth-floor (b) plans, respectively

ran on a local power plant with two generators—one with a gas engine, the backup being powered by petrol (Benchimol 1990).

The Pavilhão Mourisco is the main component of the Manguinhos architectonic and historical nucleus, listed nationally by the Instituto do Patrimônio Histórico e Artístico Nacional (Iphan).<sup>7</sup> It was strategically set on one of the hills in the region, to be seen from far away, and its position makes the best possible use of winds and sunlight.

The former Instituto Soroterápico Federal established its headquarters in a campus atop a hill facing the sea, located in a region surrounded by mangroves, although a lot has changed in the area since its foundation. Throughout one century, Fiocruz's historic buildings have witnessed several changes in the surrounding area: landfills that pushed the seashore kilometres farther away, the opening of three

<sup>7</sup>Iphan is the Brazil's Institute for Historic and Artistic Heritage.

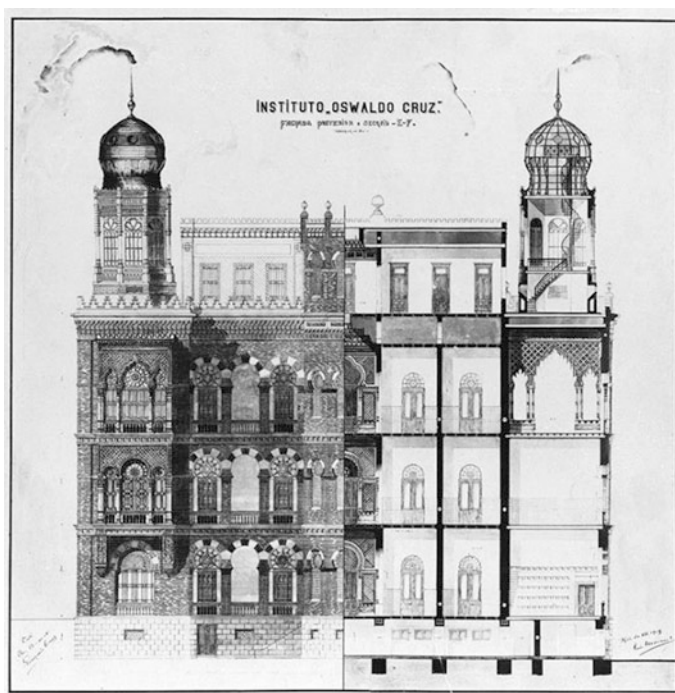


**Fig. 5** Pavilhão Mourisco in 1911

high-traffic roads, and the establishment and extinguishment of industrial plants such as an oil refinery.

Most of the damage identified on the historic buildings at Fiocruz is related to the natural ageing of the materials and lack of maintenance, but the pathologies found on the buildings are also due to weather conditions and climate change in the region. The location of the Pavilhão Mourisco, atop a hill, makes it subject to severe wind conditions, acid rain, pollution and the deposit of salts coming along with sea breeze, which all increase the deterioration rate of the building's external elements.

The Fundação Oswaldo Cruz Presidency, the Instituto Oswaldo Cruz, the Biblioteca de Obras Raras (Library of Rare Books), and the Museu da Vida currently use the building. Iphan listed the Pavilhão Mourisco as a national landmark building in 1981. Throughout the years, the Department of Historical Heritage has studied the building's history, its structure and materials—rock, mortar, ceramic and copper, amongst others. Several restoration works have taken place at the pavilion since 1988, and the building is permanently preserved and taken care of by that department.



**Fig. 6** Final design for the Pavilhão Mourisco—Elevation and cross section, by Luiz Moraes Jr., made while the pavilion was already being built (1908)

### 3 Waterproofing the Pavilhão Mourisco—A Retrospective

The Pavilhão Mourisco has suffered grave water infiltration issues throughout the years, and this has been a recurring problem. Rainwater infiltrates through the slabs of the building's roof terraces (on the fifth and seventh floors), threatening the integrity of Fiocruz's Biblioteca de Livros Raros, located on the third floor<sup>8</sup> of the Pavilhão Mourisco.

The terraces' slabs were constructed using "I"-shaped metallic framing filled with special ceramic bricks. Marseille ceramic tiles covered the fifth and seventh-floor terraces. Below these Marseille tiles there were copper plaques that functioned as a waterproofing system in the building's early days.

The first records of waterproofing interventions on the building's terraces are from September 1964, with a note on the *Diário Oficial da União*<sup>9</sup> (Brasil 1964, p. 8170), without mentioning, however, the scope of that intervention. Casa de Oswaldo Cruz's documents from 1976 indicate that a bituminous blanket

<sup>8</sup>Both the fourth and sixth floors are technical pavements and have low-rise ceilings.

<sup>9</sup>*Diário Oficial da União* is the Brazilian Official Journal, published since 1862.



**Fig. 7** View from the seventh-floor terrace, with the old cement tiles (1989)

substituted the original waterproofing system and that cement tiles ( $60 \times 60 \times 04$  cm) replaced the Marseille ones (DPH/COC/Fiocruz 2012) (Fig. 7).

By the end of the 1980s, several documents mentioned shortcomings of the terraces's waterproofing systems, most of them regarding damage to the ornamental stucco ceiling from the downstairs library, caused by the infiltration of rainwater.<sup>10</sup> Technical studies attested the need for the replacement of the bituminous blankets on the fifth-floor terrace. The intervention work that managed to substitute this bituminous blanket for a butyl one started on 1987 and focused on waterproofing both the slab and the parapet of the terraces on the fifth floor.

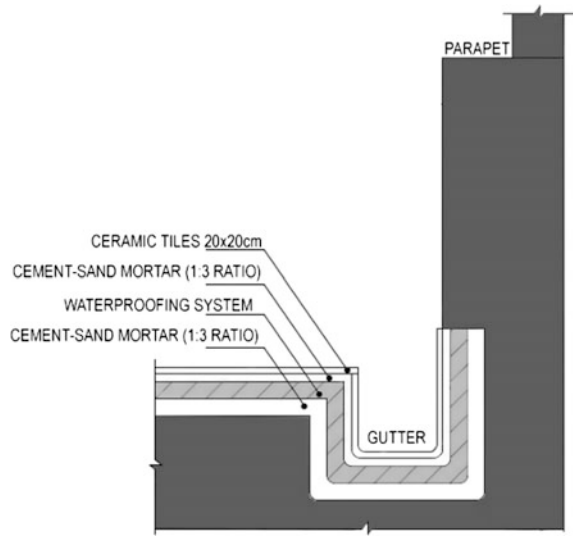
The technical report on this intervention states that the waterproofing system from the fifth-floor terrace showed severe infiltration issues, not only on the ceiling of the library, but on its collections as well. Engineers from the Instituto do Patrimônio Histórico e Artístico Nacional, after careful evaluation, stated that the bituminous blanket did not present the required standards for permeability, flexibility and tensile strength, recommending, thus, a substitution of the waterproofing system of the terrace, suggesting the use of a butyl blanket for that purpose (Fiocruz 1988).

During this intervention, the cement tiles and bituminous blanket were removed and the mortars on the parapets were demolished. A new blanket made of butyl rubber was installed over the slab, with its edges ending about 40 cm above the ground, over the parapet. The blanket was set using a hydro bituminous emulsion (diluted in a 50 % water solution) over a layer of settlement mortar. Once this lower blanket was dry, a cushion layer was fashioned with a bitumen emulsion and rubber flakes (with thickness varying from 2.5 to 3.0 mm) at a 1:2 ratio.

---

<sup>10</sup>Note that the fourth floor is a technical one, with a low-rise ceiling (1.8 m high).

**Fig. 8** Schematic cross section showing the layers of the waterproofing system around the gutters and parapets, installed in 1987



After that, a butyl rubber blanket (8 mm thick, minimum) was laid with a seam overlap of 8.0 cm, to ensure the full coverage of the terrace floor. The blanket area was then covered with bituminous felt sheets 250/15, followed by a 1:2 cement-sand ratio and 1.5 cm-thick mortar, reinforced with steel screen (Figs. 8 and 9).

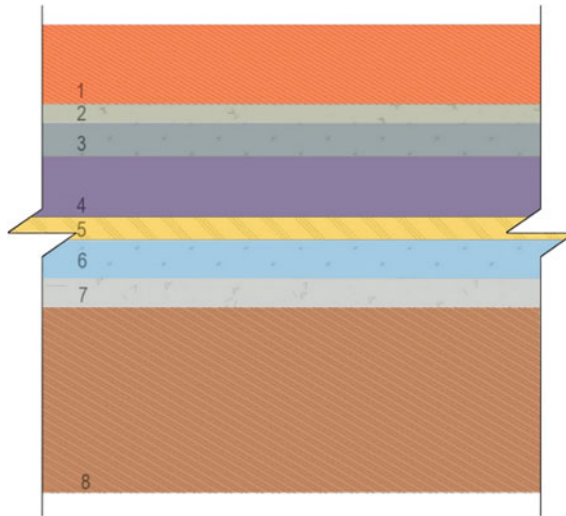
New flooring was set, this time using ceramic tiles, in the hopes they would resemble and work like the old Marseille ceramic tiles. The new industrial tiles were laid using a 1:3 cement-sand ratio mortar with waterproofing additive (at a 1:15 ratio). The expansion joints were protected with a polyurethane-based, single-component, elastic sealant (Figs. 10 and 11).

In 1990, the same process took place on the seventh-floor terrace. This time, however, polystyrene plaques were added to the system before executing the butyl rubber blanket and laying the ceramic tiles, as an insulating solution, to try to reduce the heat transmission from the slab to the sixth-floor ceiling (Figs. 12 and 13).

One of the tests performed to verify the stanching of the new waterproofing system consisted on placing water on top of the butyl blanket for 72 consecutive hours, to verify leakage build up in unwanted places. During the 1990 intervention, a glass shelter was built to protect the skylight that brings light into the fifth-floor hall.

Between 1999 and 2000, the drain pipes<sup>11</sup> were filled with epoxy vinyl ester resin so as to bulk them up, making them stronger and fatigue resistant. Only the damaged drain pipes received this treatment. Through the examination of the scheme below, one can notice that some of the pipes were coated ten years earlier, in 1990–1991. Only 13 out of 34 pipes (38 %) of the drainage system remain

<sup>11</sup>They are still the original ones, made of copper.



**Fig. 9** Layers scheme on the butyl blanket waterproofing system, where: 1 Ceramic tile laid with cement–sand mortar (1:3 ratio) with waterproofing additive. 2 Cement–sand mortar (1:2 ratio, and 1.5 cm thick) reinforced with steel screen. 3 Bituminous felt sheets 250/15. 4 Butyl rubber blanket (8 mm thick) set with vulcanising adhesive. 5 “Cradle” composed of bitumen emulsion and rubber flakes at a 1:2 ratio. 6 Dihydric bitumen emulsion diluted in 50 % water. 7 Settlement mortar, at a 1:3 cement–sand ratio. 8 Slab (steel beam and brick stuck)

**Fig. 10** Separation from the untreated surface (*on the left*) and the butyl rubber blanket (*on the right*) on the fifth floor (1988)



uncoated and do not show any kind of stress or leakage points (Figs. 14, 15, and 16).

In 2005, due to cracks spotted on the terraces, the DPH personnel hired an engineering company to run a full structural evaluation of the building. They developed a survey on the area, mapped the damage on the terraces' elements, amongst other actions. They have installed two monitoring stations to track the deformation of cracks on both terraces.

**Fig. 11** Workers laying down the ceramic tiles on the fifth-floor terrace (1988)



**Fig. 12** North wing terrace on the seventh floor (1990)



**Fig. 13** Testing the new butyl rubber blanket with a layer of water over it for 72 h —seventh-floor terrace (1990)



**Fig. 14** Construction of the shelter dome for the skylight on the seventh-floor terrace (1990)



**Fig. 15** View of the shelter dome on the seventh floor (Dec 2009)

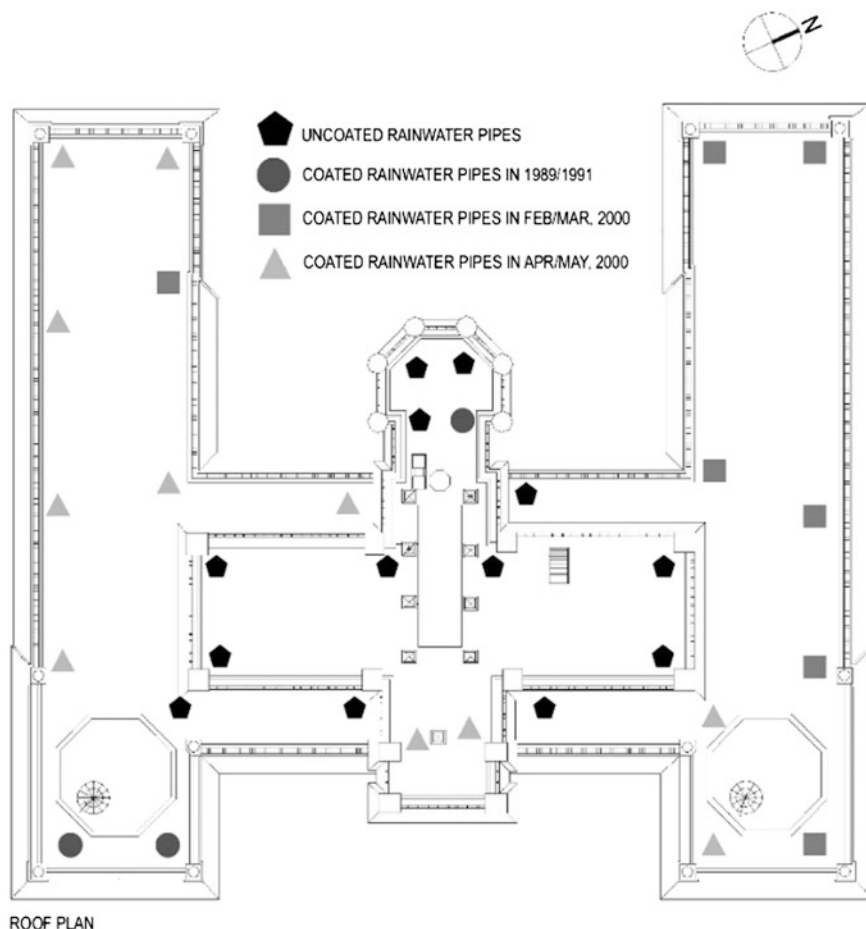


The report states that the cracks on the fifth floor result from thermal variation due to extreme temperatures in Rio de Janeiro and do not represent structural damage to the building. The report also shows that, on the seventh floor, the damage was related to the poor quality of the ceramic tiles used in the 1990s intervention (Cerne Engenharia e Projetos 2006) (Figs. 17 and 18).

The engineering company noticed the displacement of the butyl blanket in some places over the slab due to intense thermal variation at the site, which led to the fraying of the blanket next to vertical surfaces (parapets), and the appearance of cracks. The company concluded that there were no evidences of infiltration of rainwater on the slabs. Infiltration occurred only in the areas close to the external perimeter, especially on the corners of the building, with some clogged drains (Cerne Engenharia e Projetos 2006) (Fig. 19).

In 2009, DPH architects consulted several engineers to try and solve the recurring waterproofing issues at the Pavilhão Mourisco, and these consultants suggested that every waterproofing installation should be substituted by a new





**Fig. 16** Roof plan (seventh floor on the central area and fifth floor on the rest of the plan) indicating the location of the drain pipes and their interventions

system, but still they did not point out which system represented the best solution for this building (Chagas & Marques 2009).

Later on, in 2012, the DPH commissioned a new report, consulting a building waterproofing specialist, which tested the building's drainage systems and the terraces' floors for leaks. This report specifies that DPH personnel should try to solve the issues at Pavilhão Mourisco using a two-step intervention plan (Castro Saldanha Engenharia Ltda. 2012).

The first step should focus on repairing the cracks on the mortar and the terraces' external perimeter. In case said intervention does not solve the building's problems, a second step should follow, which would involve the substitution of the terraces' floor waterproofing system—working on the slab, its flooring, and casting or installing a new blanket.

**Fig. 17** Monitoring station and pins fixed to the south terrace, fifth floor (Nov 2005 —Cerme Engenharia)



**Fig. 18** Monitoring station placed by a turret on the seventh-floor terrace (Nov 2005—Cerme Engenharia)



#### **4 Intervention at the Eaves and Parapets from the Terraces**

The last physical intervention on the building started in December 2013 and lasted one year. It had the objective of stopping the deterioration processes and their consequences, in order to preserve the Pavilhão Mourisco and the Fundação Oswaldo Cruz's historical collections.



**Fig. 19** Cracks on the mortar indicating the displacement of the waterproofing blanket (Nov 2005 —Cerme Engenharia)

The Instituto Oswaldo Cruz's Entomological Collection is located in the pavilion. Dating back to 1901, it is one of the most important in Latin America, carrying 5 million insects. The number increases as the Institute researchers work on new discoveries and activities on medical entomology.

The (nowadays called) Biblioteca de Obras Raras, or Biblioteca de Manguinhos, is located on the north wing of the third floor of the Pavilhão Mourisco. Its reading hall and book collections remain in the same rooms they were designed for, and all the original furniture, decoration and light fixtures were maintained (Fig. 20).

The library holds important publications on the history of biological sciences and public health, from the seventeenth to nineteenth century. The collection adds up to 30,000 books (including various first editions), magazines, journals, brochures, leaflets and theses. It is a very important collection, and its value is directly



**Fig. 20** View of the Library's Reading Hall (Jul 2009)

related to the buildings', making it impossible to assess Pavilhão Mourisco's conservation without thinking about the conservation of these objects.

This intervention was the first of a two-step project, developed in 2012 and updated the following year. The intervention focused on repairing the cracks on the building's terraces' perimeters, and on reintegrating the architectural and ornamental mortar elements. The majority of the pathologies observed were fissures on the mortar surfaces, cracks on the parapets and black crust on the mortar and ceramic tiles that top the building's eaves (Figs. 21 and 22).

This intervention was planned to be held in two phases, so that the external perimeter of the Pavilhão Mourisco could be treated with less disturbance for the building's employees and visitors—always keeping an working entrance to the building. The first phase treated the surfaces on the eastern part of the building, and

**Fig. 21** Pathologies: cracks on the parapet, fissures on mortar and biological growth (Feb 2014)



**Fig. 22** Black crust on the external ceramic tiles (May 2014)



the second one, the western part of it. The two pictures below show the scaffolds installed for the first phase of the work.

The conservation work treated the Pavilhão Mourisco's roof terraces external elements, including decorative mortars, ceramic tiles, and copper drip edges. The battlements and turrets did not show any extensive damage and did not represent any threat to the building's structure. So, they were simply cleaned and then painted with the same formula as the mortars (Figs. 23 and 24).

The intervention work focused on stopping rainwater infiltrating through the cracks and fissures along the building's perimeter, as the latter report (Castro Saldanha Engenharia Ltda. 2012) assured that the butyl rubber blanket was still in good shape. Once again, the mortar from the inner part of the parapets was removed to try to fix the water infiltration. The edges of the butyl rubber blanket, installed in 1987 and 1990, were exposed so as to fix any deterioration process. Later, the edges were glued back to the wall and then received several layers of a plastic membrane to reinforce waterproofing qualities.

**Fig. 23** Suspended scaffolds covering the front of the Pavilhão Mourisco's terraces, on the intervention's first phase (Apr 2014)



**Fig. 24** Scaffolds on the seventh-floor terrace (May 2014)



A new cement mortar was laid over the waterproofing system, the paint formula to cover the new surface was determined through the analysis of the demolished mortar. The plastic membrane was also applied to every surface that could accumulate water (gutters, ornaments, etc.), and near the fissures and cracks. Some places were reinforced with a thin net below the new cement layer (Figs. 25 and 26).

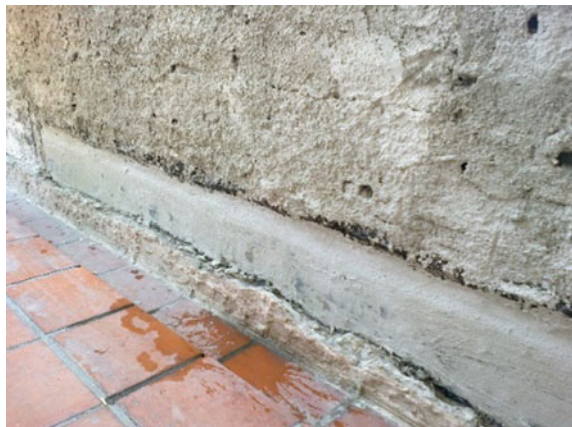
The external mortar was only removed on the areas it was extremely damaged—identified through visual and physical identification, and registered in a damages survey map and in reports for this intervention work (Fig. 27).

In some places, the cracks were too deep and thus needed to be treated in a different way. The mortar on these areas was removed, the surface was treated with the elastic membrane, new cement–sand mortar was applied to the treated surface, and a plastic screen was installed to reinforce this new mortar. When the cracks were more than 1.0 cm apart, stainless steel clamps were stapled to the concrete structure, to prevent the cracks from expanding (Figs. 28 and 29).

**Fig. 25** Treating the edges of the butyl rubber blanket (Jun 2014)



**Fig. 26** Plastic membrane applied on top of the butyl rubber blanket in order to improve waterproofing in the lower part of the parapet (Apr 2014)



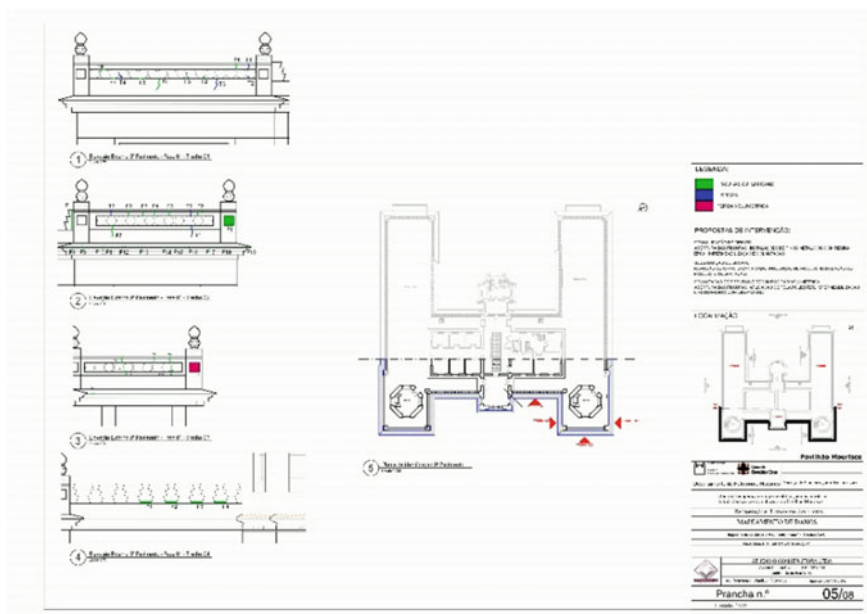


Fig. 27 Pathology and damage mapping survey—elements on the fifth-floor terrace, north wing

Fig. 28 Plastic screen used to reinforce the treatment of vastly damaged areas. The screen was installed between two layers of cement–sand mortar (May 2014)



The copper plaques located below the ceramic tiles on the eaves work as a drip edge for the building and were subject to physical intervention. The copper drip edges were removed, received anticorrosion treatment, and were finally put back in

**Fig. 29** Wide cracks in the structure, treated with stainless steel clamps (Apr 2014)



**Fig. 30** Structural damage seen at the seventh floor, north wing, eave: crack opening, affecting also the copper plaque (Feb 2014)



place before being welded back together and coated with automotive varnish (Figs. 30, 31, and 32).

In some places, some ornaments required in situ restoration, or even reproductions, to ensure the building's visual unity, and to prevent water infiltrating these fragile surfaces (Figs. 33, 34, and 35).

New ornaments were fashioned to substitute those extremely damaged (as shown in Figs. 34 and 35, above). First, the team identified the ornament in better conditions to be replicated. From this piece, a silicon mould was cast in situ to shape new ornaments. The new pieces were cast using a 1:2.5 ratio cement–sand mortar—determined after laboratorial analysis on existing material. In total, four ornaments were substituted—one on the frontal north wing, and three on the back of the south wing, all of them in the fifth-floor terrace (Fig. 35).

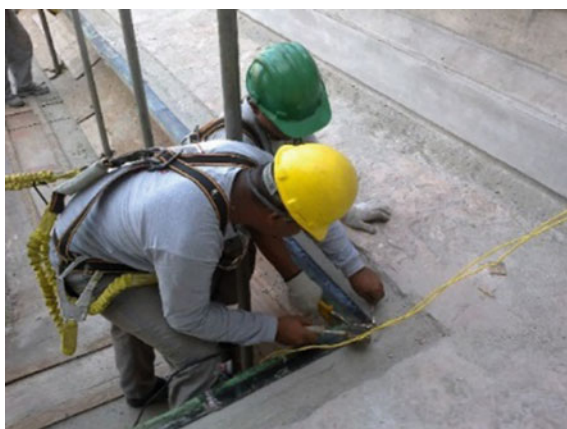
The last step taken during the first phase of the intervention work was to obtain the formula to paint the treated surfaces. The paint was produced on site using



**Fig. 31** Anticorrosion treatment to a copper plaque (Apr 2014)



**Fig. 32** Workmen welding back together the copper drip edge on the fifth-floor south wing terrace (May 2014)



cement, sand, lime, polyvinyl acetate, inorganic pigment and a water repellent solution. Tests were held to obtain the perfect ratio for the mortar elements on this building, as well as the colour shade that best fit with the vastly decorated façade. The same paint formula was used with on original mortar elements, and on the new, treated, areas, on both phases of this intervention (Figs. 36 and 37, above).

The solutions for the problems faced during this intervention work were achievable due to research held on site and the professional expertise of the people involved in it. Consultants were called upon to advise on techniques and materials

**Fig. 33** Ornament on the fifth-floor terrace, south wing, and external wall (Sep 2014)



**Fig. 34** Ornament on the fifth-floor terrace, north wing, external wall—the damage goes deep into its metallic structure (Mar 2014)

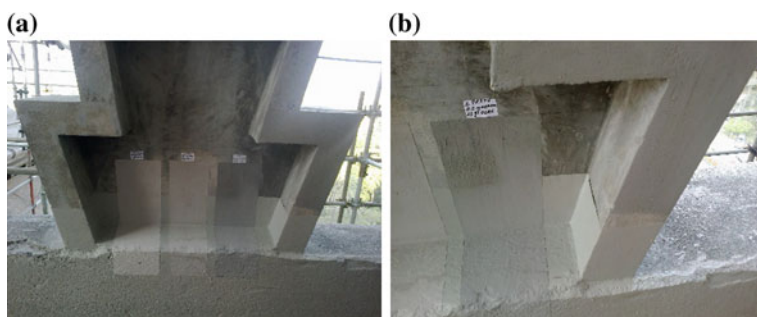


and worked alongside the DPH personnel and construction staff, in order to better perform the restoration of the mortars of this historic building (Fig. 38).

This kind of work was only possible due to intense labour, study and documentation on the Pavilhão Mourisco since the beginning of Fundação Oswaldo Cruz's Departamento de Patrimônio Histórico activities. The expertise of all professionals involved in actions held in the building over the years, recorded in reports, surveys and photographs, and kept at DPH archives, was vital to understand



**Fig. 35** Same ornament after restoration (Jul 2014)



**Fig. 36** Finishing paint colouring tests on the battlement (a) and detail (b) (May 2014)

**Fig. 37** External aspect of the parapet and the eave after the intervention—fifth-floor terrace (Sep 2014).





**Fig. 38** External aspect of the parapet and the eave after the intervention—seventh-floor terrace (Oct 2014)



**Fig. 39** Today's aspect of the fifth-floor terrace, north wing (Oct 2015)

the pavilion's behaviour. This helped to develop a detailed intervention plan and better assess the restoration.

One year afterwards, the intervention has ended; it is possible to see that its objectives were achieved (Fig. 39). One cannot see infiltration signs on the ceilings from the third and fifth floors of the Pavilhão Mourisco. It is a sign that the past intervention managed to stop rainwater from finding a way through the building's perimeters, and the waterproofing system on its roof terraces is satisfactory.

## References

- Benchimol J (1990) *Manguinhos, do sonho à vida: a ciência na Belle Époque*. Casa de Oswaldo Cruz/Ed, Fiocruz, Rio de Janeiro
- Brasil (1964) *Diário Oficial da União*. Seção I-Parte I. 14 de Setembro de 1964

- Castro Saldanha Engenharia Ltda (2012) Caderno de especificações dos serviços de impermeabilização das muretas periféricas e beirais do 5° e 7° pavimentos do Pavilhão Mourisco. Guidelines for the waterproofing intervention work
- Cerne Engenharia e Projetos (2006) Relatório final (Serviço de parecer estrutural nos terraços do 5° e 7° pavimentos do Castelo Mourisco). Technical report
- Chagas A, Marques AM (2009) Avaliação da impermeabilização existente nos terraços do 5° e 7° pavimentos do Pavilhão Mourisco e sugestões para sanear infiltrações. Departamental report
- DPH/COC/Fiocruz (2012) Relatório histórico das intervenções nos terraços do 5° e 7° pavimentos do Pavilhão Mourisco. Departamental report
- Fiocruz–Coordenação das Obras e Restauração (1988) Impermeabilização do 5° Pavimento–Relatório de Obra

# Overview of Damage to Medieval Rural Churches in Estonia

Paul Klõšeiko and Targo Kalamees

**Abstract** It is quite well known that Estonian medieval rural church structures are in poor condition. In cases of limited resources, an understanding of the underlying problems is important in managing the churches in the most sustainable way. Although the buildings are quite well investigated from the viewpoint of art history, there have not been many studies looking into the current physical state of these buildings. This chapter examines the physical condition of rural historic churches on the basis of 10 buildings in by visual inspection. The study covers most building parts. The description of the technical solutions is given, while most common and severe defects as well as their causes are revealed. The causes of deterioration are usually tied to the freeze–thaw damage mechanism and rainwater penetration. The root cause of this stems from lack of maintenance and funding. In many cases, repairs only dealt with the consequences and not necessarily with the causes. The study shows the urgent need for solutions for maintenance and indoor climate control.

**Keywords** Historic church · Physical condition · Pathology · Case study · Building survey

## 1 Introduction

The physical condition of Estonian medieval rural churches is severe. Although quite well investigated from the viewpoint of art history, there have not been many studies looking into the physical aspects of these buildings. However, in cases of limited resources, an understanding of the underlying problems is important in

---

P. Klõšeiko (✉) · T. Kalamees  
Chair of Building Physics and Energy Efficiency, Tallinn University of Technology,  
Ehitajate Tee 5, 19068 Tallinn, Estonia  
e-mail: paul.kloseiko@ttu.ee

T. Kalamees  
e-mail: targo.kalamees@ttu.ee

managing the church buildings in the most sustainable way. Mapping of the defects affecting the churches provides a useful input for developing more efficient restoration solutions, developing maintenance plans, and developing strategies and policies.

Good resources to understand the defects of historic buildings already exist—for example, English Heritage’s Practical Building Conservation series (Odgers et al. 2012; Stewart et al. 2012). Yet, as the climate in Estonia is colder, the freeze–thaw mechanism is more important. Thus, a study was carried out to provide technical insight into the condition and issues of historic rural churches in Estonia.

## 2 Methods

For this study, 10 rural stone churches (Fig. 1) were chosen to represent the sanctuaries outside larger towns that are under heritage protection and generally considered at higher risk of decay. All of them date back to the twelfth and thirteenth century, with new sections and later reconstructions added on. They are unheated and naturally ventilated throughout the year, and seldom used for services.

The study employed the following methods:

- Analysis of archive data and previous studies,
- Visual inspection of the buildings,
- Assessment and analysis of the current physical condition, and
- Interviews with restorers, congregations, and managers.

A special questionnaire was composed for the study and completed during the visual inspection. The questionnaire covered the physical condition of different building components from the foundation wall to the roof. Also, damaged components were extensively documented and photographed.

In addition, the chapter utilizes results of other studies conducted within the project “Sustainable Management of Historic Rural Churches in the Baltic Sea Region” (SMC) (Kalamees 2013):

- Microwave measurements of moisture content in the walls (Kurik et al. 2015),
- The influence of indoor climate control on risk for damages (Kalamees et al. forthcoming),
- Indoor climate control solutions (Napp and Kalamees 2015), and
- Study on plaster biodeterioration and salt damage (Kallavus et al. 2015).

As the sample was small, with every building having its distinct set of problems, no quantitative analysis could be performed. Still, the causes and outcomes can be studied and discussed and this can lead to informed decisions by policymakers, and a more sustainable use of the scarce resources in managing the buildings. Although the buildings were studied in their entirety, due to limited space, only the results and conclusions concerning the facades and interior surfaces are presented in this chapter.



**Fig. 1** Locations of studied medieval churches on the island of Saaremaa and in Western Estonia are marked with a *red* dot

### 3 Results and Discussion

#### 3.1 General

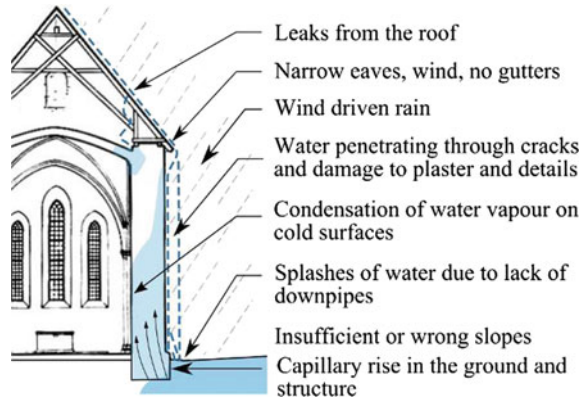
Generally, the factors affecting the physical condition of the building can be divided as follows:

- Flaws caused by indoor and outdoor climate conditions:
  - damage mechanism caused by freeze–thaw cycles in wet structures;
  - damp and cold conditions in churches caused by unregulated indoor climate;
  - condensation of water vapour on and inside the structures;
  - microbiological damage (fungi, rot, bacteria, algae, etc.); insect damage;
  - corrosion of metals; and
  - salt damage.
- Flaws caused by physical influences:
  - deformation and cracks caused by differential settlements, changes to the load-bearing mechanism and loss of load-bearing capacity; and
  - storm damage, etc.

Most of the problems found in this study are tied to high moisture content and wet structures. Figure 2 gives the main means for the excess moisture to enter the



**Fig. 2** Typical wetting mechanisms of the studied church structures



structure of the churches. The performance of the buildings and their deficiencies are highly dependent on the building management.

Usually, several of the flaws coexist, have wide influence, and cause additional damage to other building components as well. For example, differential settlements can have influence on the arches and cause collapses. Damaged or insufficient rainwater disposal systems cause damage to the facades and efflorescence of salts both indoors and outdoors.

### **3.2 Foundation and Foundation Wall**

The ground level around the churches has risen when compared to the time of construction (see Fig. 3). Also, the direction and angle of the slopes have changed. Previously mentioned factors, as well as lack of waterproofing, and porous building materials, enable moisture to penetrate and rise in the wall through capillary forces. Another problematic building component is the protruding foundation wall (Fig. 4). The top of the protrusion is often not sloped correctly and has too high water absorption, which results in wetting of the structure. Figure 4 gives an example of such cases.

Lack of rainwater disposal systems also leads to problems (Fig. 5) and is further discussed in Sect. 3.3.

### **3.3 Walls**

Typical wall structure consists of limestone or rubble stone masonry, which is sometimes covered with lime plaster and lime paint. It has to be kept in mind that of the thick masonry wall, only the surface layers could have been tied together with lime mortar and the infill can be loose material. In such cases, already the degradation of the surface layer can result in loss of load-bearing capacity and collapse.



**Fig. 3** Ground around the church is sloped towards the building and leads water to the structure, frost damage caused by excess moisture is also visible



**Fig. 4** Protruding foundation wall ought to have sufficient slopes and a cornice to lead the water away safely. Foundation wall has been wet enough to facilitate the growth of moss

## Facades

Most of the studied churches had large areas of façade in a bad state. The damage can be directly associated with high water loads caused by several factors discussed below.

Most of the studied churches had very narrow eaves (considering the height of the walls—see Fig. 30) and lacked rainwater disposal systems. Wind-driven rain



**Fig. 5** Water falling from the gutterless eaves moistens the façade while exhausting the frost resistance of the plaster, splashing water also carries soil—the foundation wall is dirty and suitable habitat for algal growth

and unevenness of the wall surface that might not be covered by the eaves cause high water loads on the wall (Figs. 6, 7, and 8).

Poor detailing of the façade elements is also one cause of water penetrations and frost damage (Fig. 9). Figure 10 gives an example of such cases. Damaged plaster

**Fig. 6** Roof covers only part of the buttress resulting in discoloration, frost damage, and wetting of the wall





**Fig. 7** Only surface layers of the masonry wall were built using binder, damage to these layers can cause collapse



**Fig. 8** Parts of the façade uncovered by eaves are exposed to high water loads, frost damage to mortar and stone is visible

contributes to the accelerated destruction of the whole façade—cracks and missing patches lead water behind the plaster and the damage spreads (see Fig. 11). Emerging problems are more easily spotted on facades that are in good condition—quick corrective actions can then be taken, which also minimize damage and the amount of necessary resources.



**Fig. 9** Due to incorrectly designed details, concentrated amounts of rainwater are able to penetrate the wall



**Fig. 10** Proper detailing of façade elements has an important role in the service life of the whole wall. Window flashing made of mortar has failed to lead the water away safely

Inherently low frost resistance of lime plasters places high responsibility on selecting the most suitable composition of the plaster for the specific application to keep the service intervals optimal. Unfortunately, in some cases the damage occurred again soon after restoring the plasters, implying that mistakes had been made either in the design of the composition or application process. Thus, additional knowledge is needed here to avoid learning from costly mistakes and damaging the valuable buildings.



**Fig. 11** Damaged plaster contributes to wetting of the wall and accelerated corrosion of the building components

### Interior Surfaces

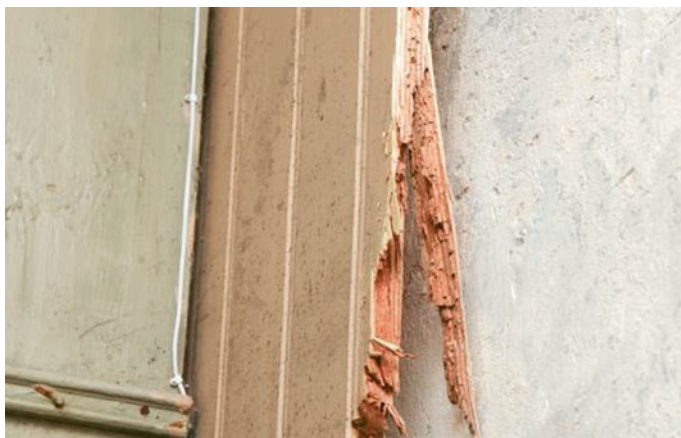
The main problem concerning the interior surfaces was discoloration caused by the growth of algae, bacteria, and fungi, and damage to the wall structure caused by crystallization of salts, and frost. All of these indicate that the moisture content of the wall is high. The microwave measurements of the moisture content (Kurik et al. 2015) and the study on indoor climate (Kalamees et al. forthcoming) confirmed the hypothesis. The average relative humidity for the whole year was 85–87 % depending on the church. According to the study, suitable conditions for mould growth were present in 45–59 % of the year. As noted on several occasions, restoration of the surfaces without removing the cause of the damage has a positive effect only for a limited time.

Depending on the level of saturation of the wall, salts can migrate through masonry as a result of capillary forces or ionic diffusion. On the layer where the evaporation takes place, the excess salts crystallize—this can happen inside the wall or on the surface. In case of interstitial crystallization, the flaking of plaster/masonry occurs due to enlarged volume of salt crystals inside the pores. When the crystallization appears on the surface (Fig. 12), the plaster and historic paintings underneath can be discoloured and damaged.

In some cases, a wooden cladding had been added on the interior surface of the masonry wall for aesthetic reasons (Fig. 13). Although the cladding was not necessarily in direct contact with the wall, relative humidity in the gap between the layers was inherently higher and suitable for mould and rot growth. In addition to the cladding itself, wooden beams and steel details tied to the wall were also placed in unfavourable conditions leading to load-bearing structures and the safety of the users possibly being at risk (Fig. 14).



**Fig. 12** Efflorescence of salts can disfigure and ruin historic paintings

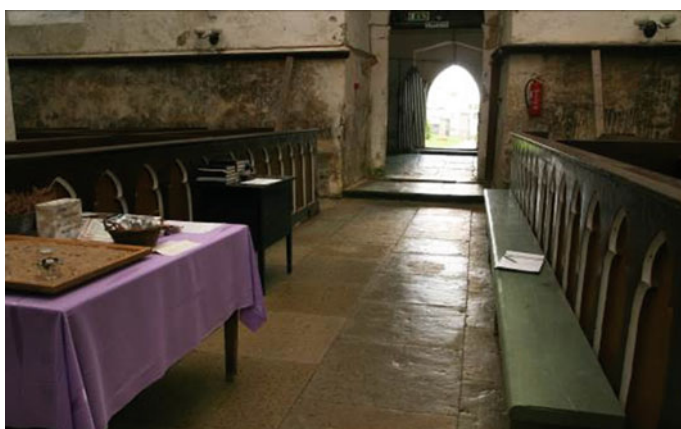


**Fig. 13** Rotten wooden cladding on the interior surface of the wall—covering up wet masonry wall causes high levels of relative humidity in the space between—suitable for mould and rot growth

Measurements of the moisture content using the microwave method (Kurik et al. 2015) showed that condensation of water vapour in spring and early summer has an important part in wetting of the structure. This is caused mainly by the low temperature of the massive walls as the churches are unheated. The water vapour content of the outdoor air is higher than the saturation content of the indoor air and excess moisture condenses on cold surfaces. This is shown in Figs. 15 and 20. Growth of algae can serve as an indicator of high moisture content (Fig. 16). Similarly, mould and bacteria can cause pink discoloration (Fig. 17).



**Fig. 14** Wooden beam has become a suitable habitat for rot. Wooden cladding on the interior surface has speeded up the process



**Fig. 15** Condensation on cold surfaces due to ventilation with moist air is an important factor in wetting of the structures (note the reflection from the moist floor)

The situation could be improved by the means of conservation heating that would avoid too low temperatures in winter. Furthermore, the heating would decrease or avoid the warming up period in spring when surface condensation and high moisture contents occur. To combat moisture damage, mechanical dehumidification could also be considered.





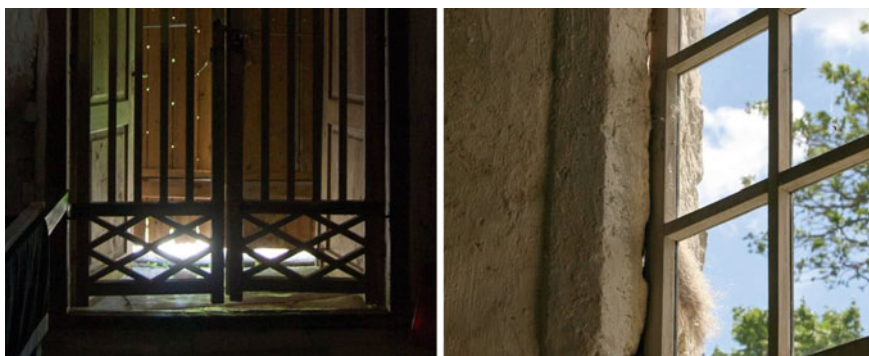
**Fig. 16** Flaking due to crystallization of salts and growth of pink bacteria and algae is also visible



**Fig. 17** Growth of mould and pink bacteria can indicate moist surfaces and cause discoloration.

### **3.4 Windows and Doors**

The churches in current study had single-glazed windows with wooden, stone, or metal frames. Airtightness of the openings was low even according to visual inspection (Figs. 18, 19, and 20)—cracks between the frame and adjoining structure were wide. This can be considered as a part of ventilation system, however, if better control over indoor climate is desired (e.g., using drying, adaptive ventilation, and/or conservation heating), attention should be paid to airtightness of the envelope.



**Fig. 18** Airtightness of the openings was visibly low



**Fig. 19** Snow has penetrated the windows due to low airtightness, possibly wetting the structure once it melts



**Fig. 20** Results of surface condensation and leaks on the interior surfaces of window sills: growth of algae, salt efflorescence



**Fig. 21** A modern glazing unit on the exterior side of the historic window preserves the original appearance while reducing thermal conductivity and air leakages

High thermal conductivity of the windows causes condensation of water vapour on glazing and frames with low interior surface temperature. Moist environment is suitable habitat for algae and also causes efflorescence of salts (see Fig. 20).

One option to improve the existing and valuable windows is to add a modern glazing unit on the exterior side of the window (Fig. 21). Hence, thermal conductivity is reduced and airtightness is improved while preserving observability of the original window from the inside of the building.

### 3.5 *Vaults and Ceilings*

An important part of the medieval churches is the vaults—built as arched masonry structures, they are extremely sensitive to uneven settlements and changes to the position of the walls. Once the supports of the vaults shift (the span increases), the contact area of the stones decreases, compression stresses increase, and the load-bearing capacity may be exhausted. Falling debris can serve as a precursor to collapse; however, it is also a danger to the persons below. To stop the deformations, several churches had been strengthened using tensile chords (Figs. 22 and 23).



**Fig. 22** To avoid additional deformations, the ribbed vault has been strengthened with tensile chords



**Fig. 23** Asymmetrical joint of the vault ribs

### **3.6 Roofs**

#### **Roofing**

Most of the studied churches had ceramic tile roofing, although wooden shingle, standing seam metal, and cement fibreboard roofing were also represented.

The main problems of the cement fibreboard roofing were cracking of the sheets and shattering along the cracks caused by wind and snow loads. Due to the large



**Fig. 24** *Left* Loss of already one sheet of cement fibreboard roofing causes a serious problem—large area of the roof is exposed to the elements. *Right* Displaced monk and nun type of tiles cannot be refitted from the inside and due to the lack of specialized equipment, the leaks in rural areas might be exist for a long time

size of the sheets, destruction of even one sheet means that 0.5–1-m<sup>2</sup> roof area is exposed to the elements (Fig. 24).

To counter the leakages of driving rain and snow (Figs. 25 and 26), tile roofs should be additionally protected using roof underlayment. As it is a relatively new practice in Estonia, roofs older than 20 years usually lack the underlayment. As extra robustness is required, a good choice for the underlayment is a modified bitumen membrane attached to a wooden deck. There are examples of adding the underlayment between the beams after the installation of the main roofing; however, those have not proven to be reliable (Fig. 27), and it is difficult to safely drain water from the top of such underlayment.

Ceramic tiles from the Soviet era are known for their varying quality. Clay that was used to produce the tiles contains pieces of limestone. During firing process, limestone in the tiles has been converted to calcium oxide. Once water reaches the particles of quicklime, the chemical process causes expansion, cracking of the tiles, and premature shattering.



**Fig. 25** Tile roofs require underlayment—driving rain and snow cause additional moisture load on the building, underlayment also provides additional protection in case of loss of tiles



**Fig. 26** *Left* Snow has penetrated the roofing and will cause an additional moisture load on the structure once it melts. *Right* Snow has penetrated a window

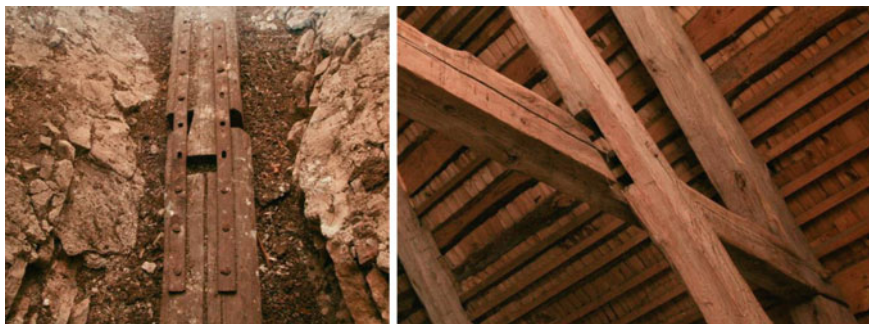


**Fig. 27** Underlayment added after the main roofing has lower reliability, safe drainage of water may also be difficult to accomplish

### Load-Bearing Structures of the Roof

Load-bearing structures in studied churches were all wooden trusses that were supported by load-bearing walls and posts, in some cases also by the vaults. Structures built before mid-twentieth century are usually composed of handmade wooden elements. Connections are made using wooden pins; steel/iron is only used in bottom splices (Fig. 28 left). Contact with wet masonry structures creates suitable habitat for wood decay. Visual inspection exposed urgent need for intervention both in connections (Fig. 28 right) and main elements. Soviet-era trusses are characterized by wide use of industrial materials and steel components.

The technical state of the load-bearing structure is largely influenced by the soundness of the roofing—if the structure has been protected from the elements, it is in good shape and ready to perform correctly in the future as well. Damaged parts (Fig. 29) were usually in contact with moist or wet surfaces (truss supports, leaks through the roof, etc.).



**Fig. 28** *Left* Deformed bottom splice causes a change in the truss geometry and possibly an additional lateral load on the walls. *Right* Connection with wooden pin needs urgent intervention

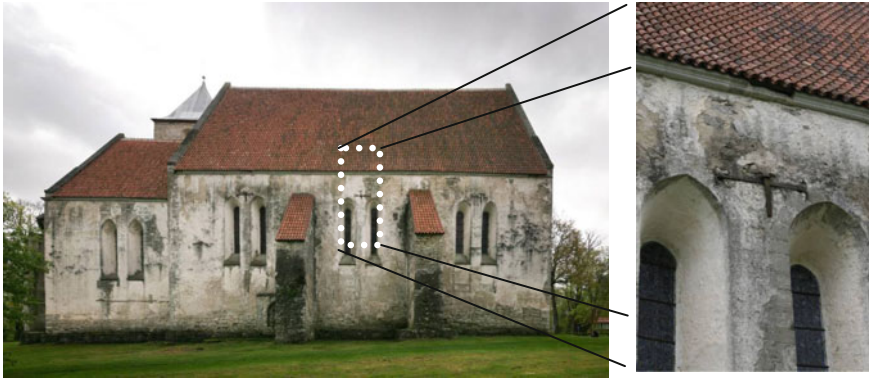


**Fig. 29** *Left* Leaks and contact with a moist wall cause wood decay. *Right* Almost fully decayed connection needs prompt repairs

### 3.7 *Eaves and Rainwater Disposal Systems*

Most of the studied churches have very narrow eaves and completely lack rainwater disposal systems. (Fig. 30 represents the typical situation.) Unfortunately, the situation has not been improved during roof refurbishments. Probably the historical accuracy was preferred over safer solutions and higher reliability. The consequences of the missing systems are described in Sect. 3.3.

In order to extend the service life of the plaster, proper rainwater disposal systems (gutters, downpipes) should be installed. It is clear that the intervention affects the appearance of a heritage building and should be carefully considered and designed. However, positive effects (longer service interval and lifespan, lower moisture load, etc.) should not be underestimated. Proper rainwater disposal systems are essential in areas where concentrated amounts of rainwater are to be expected (roof valleys, long slopes, outlets through parapets/walls, etc.).



**Fig. 30** Narrow eaves without rainwater disposal systems offer no protection against driving rain while being a contributing factor to the wetting of the structure and also to the damage on the interior surface

Risk to the underlying structures is especially high in places where concentrated amounts of rainwater occur (e.g., ridges, water spouts, and long slopes) and proper rainwater disposal systems should be essential there (Fig. 9).

### 3.8 Floors

Stone slab floors were most prominent in the studied churches, while wooden floors and wooden floor built atop of stone were also represented.

Due to the lack of waterproofing and drainage, both soil and air under the floors are moist. Such conditions are suitable for mould and rot growth and requires great care when using wooden details.

Different factors (still air, direct contact with wet surfaces) contributed to a case of fungal infection in one of the studied churches. Dry rot causing fungi can spread in suitable conditions very rapidly and destroy the whole floor. Floor with only a couple of visible fruiting bodies (Fig. 31 left) might seem fine on first sight, but opening of the structure will reveal the severity of the situation (Fig. 31 right). In case the infection is discovered, a thorough inspection is required to assess the spread of the contamination. Swift eradication is necessary to avoid escalation (through mycelia and spores). To avoid reoccurrences of the infections, guidelines of the specialists have to be strictly followed and the causes of the problem removed. Subsequent inspections are also necessary.

Main problem of stone floors was unevenness (Fig. 32 right) possibly caused by frost heaving. Unevenness was severe enough to cause tripping of the visitors. Capillary moisture transfer was not always taken into account when placing benches and other wooden details on stone floor—signs of wood decay occurred on them as well.





**Fig. 31** Wooden floor infected with rot causing fungi from the top (*left*) and below (*right*)



**Fig. 32** *Left* Wooden floor with fungal infection. *Right* Uneven stone floor

## 4 Conclusion

In this study, 10 medieval churches under heritage protection in rural regions of Estonia were mapped for defects. Currently, all of the churches were affected with algal, mould, and bacterial growth on interior surfaces. Salt efflorescence caused discoloration and flaking of the plaster. The façades had wide areas of frost damage with flaking due to salt crystallization also visible.

Most of the defects were connected with wet structures. The wetting of the façades is usually caused by leaks from the roof, narrow eaves, and lack of

rainwater disposal systems, wind-driven rain, damaged plaster, water vapour condensation on cold surfaces, capillary rise from the foundation wall due to wrong slopes and lack of horizontal water barrier.

To manage the heritage buildings in a sustainable way—taking into account the value and limited resources—informed decisions have to be made. In order to do that, defects and their causes have to be understood. However, on several occasions it was apparent that restoration process had only managed to deal with the consequences of the problems, while the sources of the issues were left unresolved.

The state of the buildings has to be monitored continuously and systematically in order to detect the issues before the damage has become widespread and resource requirements higher. As the aim is to preserve the valuable buildings for future generations, in the long run the sustainable choice is to prevent the problems instead of repeated remediation of the damage.

As the causes of the damage were mostly similar among the different buildings, the following should be checked and corrected as necessary:

- Roof has to be sound and raintight, use of underlay membrane helps to prevent accidental leakages and leakages in the event of damage to the roofing.
- Rainwater disposal systems and wide eaves are essential in reducing the rain load on the facades (both from wind-driven rain and fall-off from the roof).
- Façade plaster should be undamaged as the cracks lead water to the structure. Correct composition of plaster is crucial to its optimal lifespan. Façade elements (window flashings, etc.) should lead the water away safely.
- In order to reduce the capillary rise from the ground, the immediate landscape around the building should be sloped to lead the rainwater away. Although costly and difficult to implement, waterproofing might also be considered.
- Keeping the indoor climate in suitable conditions (by using a dehumidifier, heating, and/or adaptive ventilation) can limit the efflorescence of salts, growth of bacteria and mould.

It has to be born in mind that the durability of materials used in historic buildings may be lower than their modern analogues. Thus, the service interval might have to be shorter, or more careful consideration will have to be given to limiting the effect of deteriorating factors.

**Acknowledgements** The authors are grateful to Simo Ilomets, Endrik Arumägi, Üllar Alev, Lembit Kurik, and Urve Kallavus from Tallinn University of Technology for the help in conducting the survey.

The study has been conducted as part of the IUT1-15 project “Nearly-zero energy solutions and their implementation on deep renovation of buildings”. These data were gathered as a part of an international collaborative research project “Sustainable Management of Historic Rural Churches in the Baltic Sea Region” (SMC, <http://smcproject.org.ee>). The financial support of the Central Baltic Interreg IVA Programme 2007-2013 and Estonian Ministry of Education and Research are gratefully acknowledged.

## References

- Kalamees T (2013) The final report of research of project “Sustainable Management of Historic Rural Churches in the Baltic Sea Region (SMC)”. Tallinn University of Technology / Conservation Centre Kanut, Tallinn-Visby
- Kalamees T, Väli A, Kurik L, Napp M, Arumägi E, Kallavus U The influence of indoor climate control on risk for damages in naturally ventilated historic churches in cold climate. *International Journal of Architectural Heritage* (forthcoming)
- Kallavus U, Traksmäa R, Kalamees T, Kurik L (2015) Extent and reasons for biodeterioration, salt distribution and damage of plaster in Estonian medieval churches. In: *Proceedings of 1st International Symposium on Building Pathology (ISBP 2015)*
- Kurik L, Kalamees T, Kallavus U (2015) The use of microwave method for diagnosis of moisture content of massive dolostone walls of medieval churches. In: *Proceedings of 1st International Symposium on Building Pathology (ISBP 2015)*
- Napp M, Kalamees T (2015) Energy use and indoor climate of conservation heating, dehumidification and adaptive ventilation for the climate control of a medieval church in a cold climate. *Energy Build* 108:61–71. doi:[10.1016/j.enbuild.2015.08.013](https://doi.org/10.1016/j.enbuild.2015.08.013)
- Odgers D, Henry A, Martin B, Wood C (2012) *Practical Building Conservation: Stone by English Heritage*. English Heritage, Ashgate Publishing Limited, Farnham
- Stewart A, Stewart J, Martin B, Wood C (2012) *Practical Building Conservation: Mortars, Renders & Plasters*. English Heritage, Ashgate Publishing Limited, Farnham

# Finding Faults with Residential Buildings

Nigel Isaacs, Jim Bowler and Ethan Duff

**Abstract** Since 2004, Buildsure Associates has provided house inspection services, completing over 700 inspections. This chapter describes the inspection process and the methods used to communicate the results to the house owner. A random sample of 70 reports was taken and processed into a database which has been subject to statistical analysis. The large majority were for free-standing timber-framed houses with different claddings. 46 % of the houses had only suspended floors, 30 % only slab-on-grade, and the rest both floor types. Just one-fifth (21 %) of the houses could be considered to be in excellent condition. The full set of reports was also examined to select common problems, and these are discussed with appropriate site photographs. Given that when a house is being sold, the seller wishes to present it in the most positive light, this would suggest there is a very large, currently unmet, need for house maintenance work. Three common issues have been identified: asbestos (present in 36 % of reports), high moisture levels (35 % mean timber moisture levels of 14 % or above), and subfloor ventilation (53 % of the timber bearer moisture measurements were in the 16 % to over 22 % range). The identification of problems is a first step to their resolution. Future analysis of this database, along with other research exploring the condition of New Zealand houses, is being undertaken and will help to lead not only to improved durability of the houses but also create an improved environment for living.

**Keywords** Houses · Moisture · Maintenance · Asbestos · Subfloor ventilation · New Zealand

---

N. Isaacs (✉) · E. Duff  
School of Architecture, Victoria University of Wellington,  
Wellington, New Zealand  
e-mail: Nigel.Isaacs@vuw.ac.nz

E. Duff  
e-mail: ethanduff1@gmail.com

J. Bowler  
Buildsure Associates Ltd., Wellington, New Zealand  
e-mail: Buildsureassociates@clear.net.nz

**Fig. 1** House condition assessment logo



## 1 Introduction

The shift to a performance based, national building code in 1992 (Government of New Zealand 1991) coupled with changes in construction training over the following decade, has meant that house purchasers can no longer rely on a simple, visual prepurchase inspection. An inspection using the skills of an experienced construction professional with knowledge of common building faults and failures provides a degree of security for the prospective purchaser that potentially expensive failures or inadequacies have been identified.

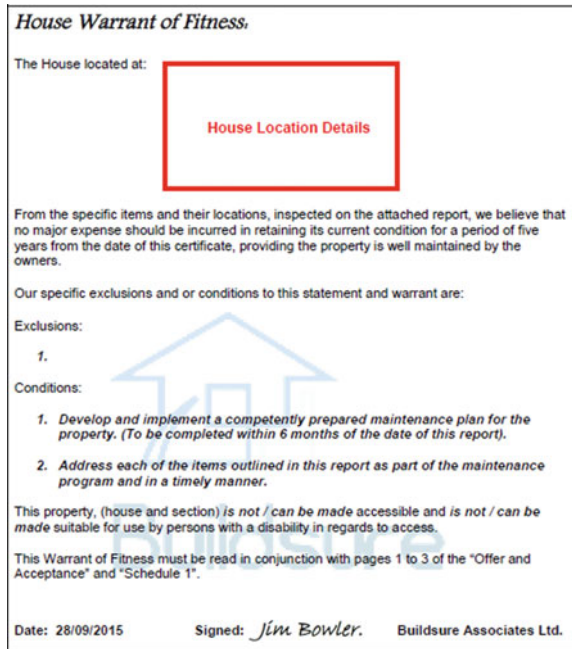
Buildsure Associates Ltd.,<sup>1</sup> and its predecessor, is a private company that has been undertaking house inspection services since 2004. Approximately 700 inspections have been completed, the majority for a house condition assessment (Fig. 1) of stand-alone houses. This results in a detailed report and a “House Warrant of Fitness.” The warrant is subject to the general requirement that any necessary maintenance being properly undertaken by the property owner during that five-year period. In addition, specific exclusions may be applied that are relative to that particular house and conditions (e.g., develop and implement a maintenance plan). Figure 2 provides an example of a completed “House Warrant of Fitness” (WOF).

This chapter provides an overview of the inspection process, a discussion of key inspection skills, and an overview of the database extracted for analysis followed by a review of the most commonly found building failures.

---

<sup>1</sup><http://buildsureassociates.co.nz/>.

**Fig. 2** Example of building WOF



## 2 Inspection Skills

Buildsure Associates Ltd has 8 project leaders available throughout the country to undertake house inspections. The majority have around 40 years of site and inspection experience, as well as appropriate academic, professional, or trade qualifications. In addition to the initial training, regular exchange of information and experiences among the group ensures consistency of assessment and prompt identification of market changes. They not only undertake visual inspections but also examine building spaces and locations that would not normally be visited. This requires the ability to deal with heights as well as enclosed spaces.

The inspection is recorded with brief notes during the process, including any measurements. A digital camera, with both wide angle and telephoto lenses, is used to record evidence of the overall building as well as specific items or issues of interest.

The report is normally completed after the inspection, peer reviewed, and then provided to the client in electronic (PDF) form.

### 3 Process of Inspection

A house inspection takes approximately 4 h and involves a detailed inspection of the building and site, including assessing the condition of habitable rooms, plumbing services, heating and cooking utilities, electrical, internal stairs and doors, moisture readings at selected openings, roof space, foundations and subfloor, exterior of property including windows, doors, and stairs, stormwater and other external services, roofing, decks or balconies, garage, and any other external out buildings. The reports are from 40 to 50 pages long and include numerous photographs to document any issues of concern. The warrant and supporting documentation provide independent advice to vendors, purchasers, real estate agents, and lenders as to any likely major building costs to be incurred during the next five years.

Table 1 lists the main assessment headings and provides a brief description of the issues investigated and reported under each heading. The wide coverage is necessary to deal with the full range dwelling types, which include free-standing houses, semidetached, row houses, and apartments. However, historically, the majority of New Zealand dwellings are free-standing houses with suspended timber (or since the 1960s, manufactured timber product) floors, timber frame with timber or brick veneer or cement board cladding, and long-run iron roofing (Isaacs 2015).

The final report deals only with those features found in the specific house, e.g., if there is no deck, then that section is not in the report.

### 4 Sample Database

A random sample was taken from the approximately 700 reports by placing them in chronological order and selecting every 10th report. These reports were then abstracted into a spreadsheet for detailed analysis.

It should be noted that this is not a random sample of all New Zealand houses, as the database only includes houses for which reports have been commissioned, generally for the purposes of sale. This database has been used to provide numerical analysis, while a review of all reports has been used to select examples of common building failures.

Four national “House Condition Surveys” of randomly selected houses have been undertaken with BRANZ (1994, 2000, 2005, and 2010) with each inspecting approximately 500 houses. These provide a national overview, identifying common issues and problems requiring specific interventions (Page 1995; Clark 2000, 2005; Saville-Smith et al. 2011).

The first inspection in the sample was undertaken in December 2011 and the last in October 2014. All the sample houses were located in the greater Wellington Region. The date of construction ranged from 1875 to 2010.

**Table 1** Assessment coverage

Assessment heading	Description of coverage
Preliminary	Person and date of request, date and time of assessment, author, and reviewer
Identification	Address and photograph
Area and age	Floor area and age
Building construction	Description of materials
Internal layout	Description of internal layout and orientation
Interior condition	Walls, ceiling, floor, joinery, hardware, windows, extractor fan, etc
Sanitary services	Number and facilities of bathroom(s), toilet(s), laundry, hot water system
Kitchen	Condition of finishing and fittings
Heating	Types and condition of heating and ventilating system(s), e.g., fireplace
Electrical	Basic electrical safety check, including type of cables. Smoke alarms
Storage	Presence of wardrobes, storage area(s)
Internal doors	Construction, condition, glazing
Internal stairs	Consistent tread/risers, safety, condition
Moisture readings	Selected openings and bottoms of jambs
Roof space	Access, repair, insulation, water header tank, rodents
Subfloor	Slab-on-ground or suspended floor, piles, ventilation, finish, condition
Exterior of property	Condition and any obvious issues
Wall cladding	Material(s) and condition(s), rot or decay, asbestos
Windows	Construction, condition, safety glass (if applicable)
Exterior doors	Construction, condition, glazing
Roof cladding	Pitch, construction, condition, asbestos
Roof water collection	Construction, concealed gutters, condition, water removal, asbestos
Plumbing and drainage	Construction, condition, interconnection storm, and waste systems
Balconies and decks	Construction and condition
External stairs	Consistent tread/risers, safety, condition
Garage and driveway	Construction and condition, connection to house, driveway
Outbuildings	Use, construction and condition
Paths and steps	Construction, condition, suitable for restricted mobility
Retaining walls	Construction and condition
Fences	Construction and condition
Site exposure	Wind, contours, vegetation
Environs	Local issues, e.g., cliff edge and geothermal area
Weather-tightness risk	Visual assessment of possible risk



The large majority of houses had timber framing with different claddings. Weatherboard cladding (timber, cement, or plastic weatherboards) was found in a majority of the inspected houses (57 %), a further quarter had fiber cement (asbestos or treated cellulose) boards (23 %), 7 % had Exterior Insulation and Finish Systems (EIFSs), 4 % were brick veneer, and the rest reinforced concrete or concrete block.

Just over half of the houses had corrugated iron (54 %) roofing, followed by pressed metal tiles (30 %) and concrete tiles (13 %) with just 3 % some other roofing material.

Just under half (46 %) of the houses had only suspended floors, about one-third (30 %) had only slab-on-grade, and the rest (24 %) had a mixture of the two floor types.

## 5 Maintenance Management

As part of the process of creating the database, an assessment for each of the houses of the level of maintenance was made. This was based on the general descriptions as well as the specific detail recorded for each component. Table 2 provides a brief description of the levels, from Level 1 where the house has excellent maintenance through to Level 5 where the house had more than two major problems, e.g., moisture problems and asbestos very likely to be present.

The majority (58 %) of the houses had Level 1 or Level 2 maintenance, or in other words, most of the houses are reasonably well maintained, with minor wear and tear issues. Just under a third (29 %) had one noticeable issue (e.g., needs repaint). One in eight (12 %) of the houses (Levels 4 or 5) had major maintenance problems to be dealt with by some future owner.

While in one way, this is a reassuring result, suggesting the majority of householders maintain their homes in good to reasonable condition, on the other hand only one-fifth (21 %) had houses in an excellent state of maintenance suggesting there is considerable room for improvement.

**Table 2** Maintenance level

1. Excellent	21 %
2. Minor, general wear, and tear	37 %
3. Wear and tear plus 1 noticeable issue	29 %
4. Poor condition plus 1 or 2 major problems	9 %
5. Major problems (more than 2)	3 %
0. Missing or insufficient data	1 %
Total	100 %

## 6 Common Building Failures

The full selection of reports was examined for common failures, with additional reporting from analysis of the 1-in-10 database. Examples are provided starting from the subfloor and moving vertically through the house to the roof.

One common issue is the wide range of potential problems, whether due to adverse exterior events (e.g., heavy rainfall) or to householder activities (e.g., do-it-yourself modifications). In some cases, the issues are built-in at construction (e.g., lack of a flashing), while in others they are an unforeseen consequence of the occupants (e.g., a gardener building up the earth bed outside the house and blocking the subfloor vents). In almost all cases, the issue and consequential failure could have been stopped but for a lack of basic building science knowledge or understanding.

Many of these have potential health and safety implications for the house owners or occupants, but the focus here is on the building rather than the impact on the occupants.

### 6.1 Subfloor Moisture

New Zealand does not have a tradition of basements—houses are built directly over the ground, raised on piles or foundation walls. Slab-on-ground poured concrete floor has in recent years become more widely used.

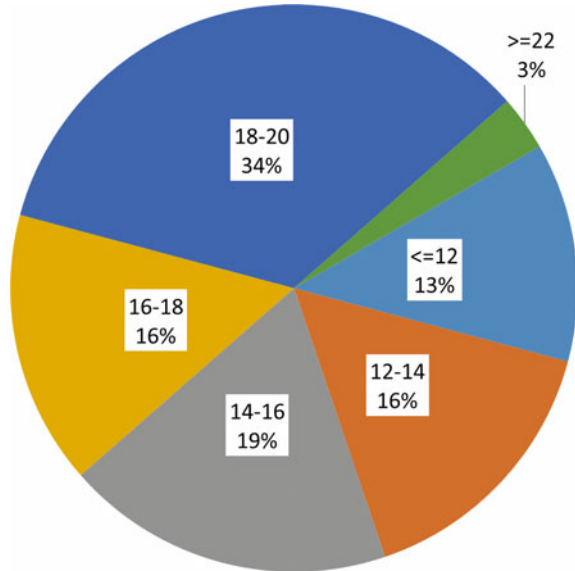
Ground moisture will evaporate from the earth over time, and unless stopped or removed will build up to unacceptable levels that can lead to decay of timber and corrosion of fittings. This can be a particular problem when ground water is high, or external surface water can enter the subfloor space.

Methods for controlling subfloor moisture include the use of ventilators to ensure adequate external air can ventilate and remove the moisture, or damp proof membranes (DPM) to stop the moisture entering the subfloor space. Evidence of unacceptably high subfloor moisture, and hence failure of either ventilation or DPM, can be detected through high levels of moisture in timber bearers or subfloor framing.

There are many ways water can end up in the subfloor area under a house apart from the soil. Broken pipes, disconnected bath or sink drains, damaged stormwater pipes, or blocked gully traps can lead to soil being washed away, piles losing ground connection, or ponding. Overtime, this water also has the potential to so increase the subfloor moisture level as to promote decay in the exposed timber. In addition, the evaporation will increase the moisture load inside the house requiring additional space heating or leading to damp, unhealthy living spaces.

Where there was a subfloor, bearer moisture measurements are included in the inspection. A total of thirty-two subfloor moisture measurements were available for analysis, of which Fig. 3 shows that over half (53 %) were in the 16 % to over 22 % range. This is a high, and ultimately unacceptable, level of moisture.

**Fig. 3** Proportion of houses with given subfloor moisture levels



**Fig. 4** Debris resulting from a nearby stream flooding



Although perhaps an extreme example, Fig. 4 shows the collection of debris found underneath a house. These had been deposited as a result of heavy rainfall leading to the nearby stream overflowing its banks, flooding neighboring properties. The flood waters carried the debris into the subfloor area, leaving behind the potential for decay or fire.

Figure 5 illustrates an (unfortunately) far more common problem—subfloor external vents being blocked by garden work. The soil level has been built up, possibly over time, and the occupants have not taken care to ensure adequate subfloor ventilation continues to be provided. This can lead to destruction of flooring; for example, manufactured timber board when subjected to long periods of

**Fig. 5** Blocked subfloor vents



continuous high levels of dampness can delaminate, while timber (even when treated) will rot.

## 6.2 Subfloor Structure

New Zealand is a seismically active country requiring great emphasis not only on structures being able to deal with normal static loads but also being able to withstand reasonable dynamic loading. Commonly damage comes from houses falling off their piles due to inadequate fixings.

Figure 6 illustrates a “do-it-yourself” nightmare. Someone (probably a house occupant at some unknown time) has excavated under the house to provide storage space. The work has undermined both of the piles, resulting in loss of footing. The second pile also shows no wire tie to link the bearer to the pile in case of earthquake (Pringle 2010).

Figure 7 shows a preservative-treated pile supporting a timber bearer. However, there are no visible fixings tying the pile to the bearer, nor is there a moisture barrier to stop moisture traveling up the pile to the untreated timber, potentially leading to its decay and failure. The bearer shows either a joint or deficit which does not appear to be physically restrained.

## 6.3 Wall Moisture

Normal moisture levels for wood framing and cladding range from 8 to 14 %. It is widely recognized that significant decomposition by wood-rotting fungi will occur above the fiber saturation point at 28–30 % moisture content. Depending on the type fungi present, preconditioning and limited decomposition may occur at

**Fig. 6** “Do-it-yourself” excavation with rear pile not tied to bearer



**Fig. 7** Untreated floor bearer rests on treated pile



moisture levels as low as 20–25 %. Several fungi, including certain species of *Aspergillus* and *Penicillium*, grow at water activities as low as 0.70–0.80, which correspond to wood moisture contents of approximately 16 %.

Moisture readings are measured using an electronic Surveymaster Protimeter<sup>2</sup> which provides both a digital readout and a scale of color-coded lights. Figure 8 shows an illustration of the Protimeter in use. Moisture readings are normally taken

<sup>2</sup><http://www.ge-mcs.com/en/moisture-and-humidity/moisture-meters/surveymaster.html>.

**Fig. 8** Moisture meter in use on a piece of rotten timber



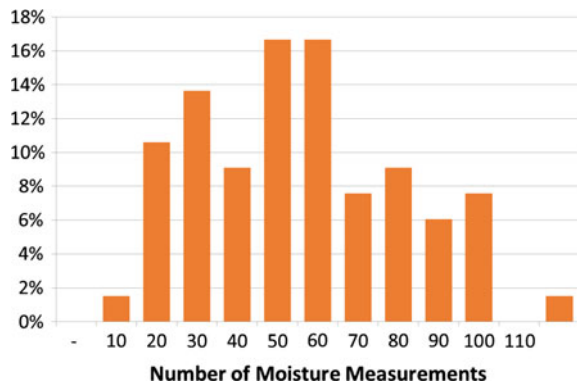
on the inside wall of all external openings, heads, jambs, and sills. Where any other areas visually indicate moisture ingress, then readings are also taken.

Detailed moisture measurement data were available for 66 houses in the sample database. In each house, a number of measurements were made of the moisture levels—a minimum of 8 and a maximum of 112. Figure 9 shows that in 52 % of the houses, more than 50 readings were made.

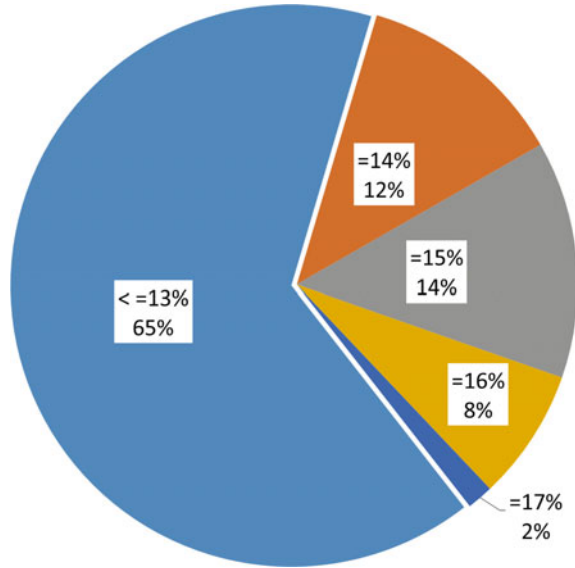
Figure 10 shows the proportion of houses by count by the mean moisture level. Nearly two-thirds (65 %) of the inspected houses had mean moisture levels below 13 %. A moisture reading of 14 % is considered the point at which “borderline” risk presents itself.

However, the use of the mean moisture level as a measure disguises the distribution of moisture levels—the average of 13 and 13 % is the same as the average of 9 and 17 %, yet in the first case, there should be no moisture problem but not in the second case. Figure 11 shows the proportion of houses by count by the maximum measured moisture level. Just 12 % of the inspected houses had a maximum

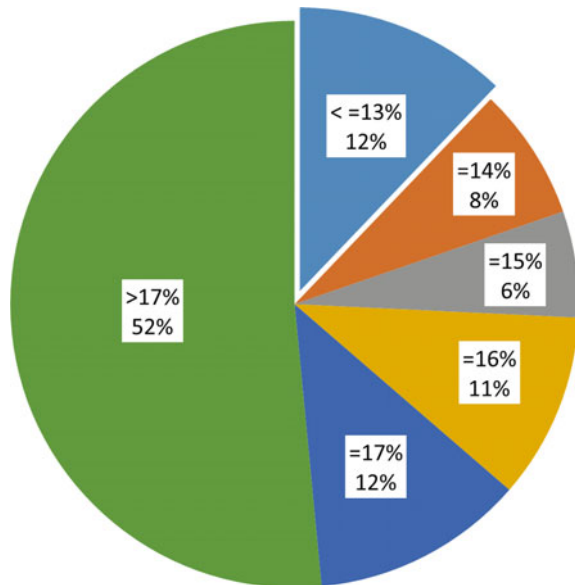
**Fig. 9** Number of moisture measurements made in each house



**Fig. 10** Houses with mean interior wall moisture level



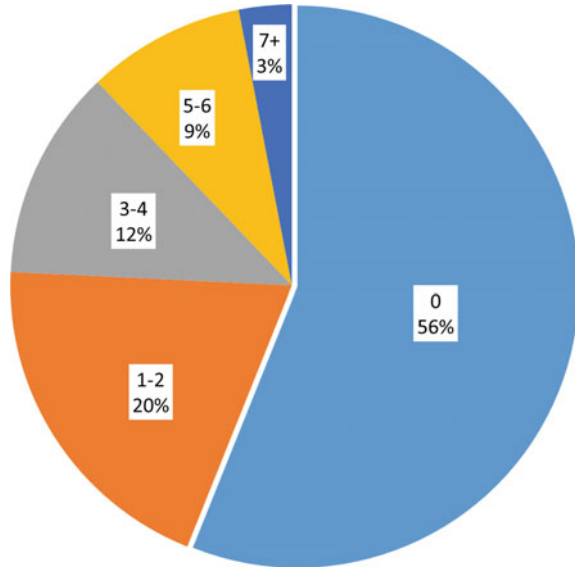
**Fig. 11** Houses with given maximum interior wall moisture level



moisture level of below 13 %. In 88 % of the houses, the moisture level was so high in one or more locations as to give concern.

In softwoods, the main housing timbers, once the moisture content is above about 14 %, any further increase would be likely to produce: degrading of the timber strength; corrosion of fixings; expansion of the timber in the fixing cavities;

**Fig. 12** Number of locations in houses with interior wall moisture levels above 18 %



mold growth; and finally, degradation of finishes (paint/wallpaper, etc.). At around 16 % moisture content, fungal attack is likely to occur, with the possibility of danger to occupant’s health (Andrews 2002; Lstiburek 2002). These expectations are matched by the experience of house surveyors. Figure 11 shows this was found nearly a quarter (23 %) of the inspected houses.

Figure 12 takes the data from Fig. 11 to examine the proportion of houses with the given number of moisture readings over 18 %. In 3 % of the houses, there were 7 or more locations with moisture levels above 18 %. The majority of cases where the moisture level is above 18 % are a direct result of poor maintenance by the owner or the owner’s agents. There was no obvious relationship between house age and the finding of higher levels of moisture—high levels could be found in very new or very old houses. The only difference is that houses built prior to about 1960 are likely to use native timbers which have a higher level of resistance to high levels of moisture, than the softwood *pinus radiata* widely used since then.

### 6.4 External Water Management

Removal of rainwater can be expected to be a requirement in all but the very driest locations. Guttering, down pipes, and water disposal system must work together to meet the requirements of the largest realistic rain intensity.

Although water most commonly comes from above, low-lying areas or locations close to creeks, streams or river can suffer from flooding, resulting in the case as



**Fig. 13** Ponding due to inadequate fall

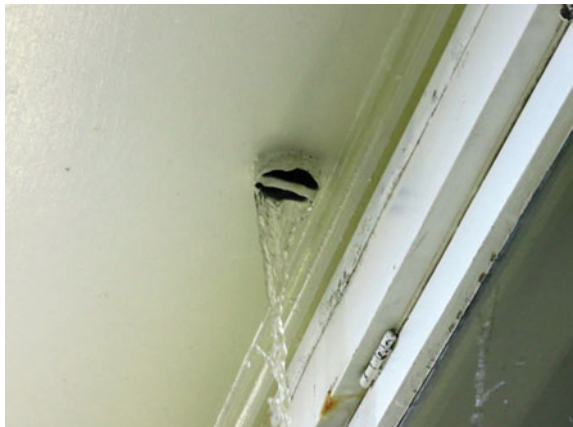


shown in Fig. 4. If regular flooding is likely, then exterior water management work is required.

Even when the external hard surfaces have been planned to provide runoff, the construction may not have achieved the planned goals. Figure 13 illustrates a concreted exterior area in which even though the drain has been located in a position where the fall should direct water, in practice, the fall has not been correctly implemented and ponding results. Although this is an external, and visible, example, this can also occur in hidden locations.

Water can also come from managed or planned sources. Overflows, such as that shown in Fig. 14, are required for header tanks, toilets, and other facilities controlled by ball cocks or water switches. Here, the overflow is behaving as required—the ball cock has failed in the open position, so excess water is being dumped through the overflow pipe. However, if the flow is neither seen nor heard, over a period of time significant water problems can result.

**Fig. 14** Stuck ball cock results in overflow



**Fig. 15** Guttering blocked by vegetation



**Fig. 16** Gutter joint failure



Overhanging vegetation, including trees and creepers, can lead to debris being left in the gutter which may not be either readily visible or removable. Figure 15 shows a gutter blocked by vegetation from nearby trees and plants. Regular maintenance is required; otherwise, the trapped water can lead to corrosion and ultimate failure of the gutter or to overflowing and the delivery of stormwater to areas ill-equipped to deal with it.

Guttering failure can also occur due to movement, as shown in Fig. 16. The joint has failed, probably due to movement of the guttering or inadequate installation.

### 6.5 Concrete Spalling

As a narrow country surrounded by the sea, no part of New Zealand is further than 120 km from the sea. This leads to high level of wind-borne salt, with consequential the potential for high levels of corrosion. While concrete practices have developed over time (Lee 2011), failures such as shown in Fig. 17 are not uncommon. The concrete spalling (also called “concrete cancer”) results from the

**Fig. 17** Chimney concrete spalling



steel reinforcing rusting. As the rust occupies a greater volume than the steel from which it is originated, the expansion can push off the external concrete, exposing the steel and creating a cycle of self-destruction.

While the spalling as shown in Fig. 17 is easily observable, spalling can occur in seldom visited or inaccessible locations, such as concrete piles in the subfloor area.

## **6.6 Corrosion**

Even when protected with galvanizing or a proprietary treatment, in the long term it can be expected that steel will rust. Figure 18 illustrates external rust in a roof gutter, but it is also likely that the condensation which has formed on the underside of the steel will have led to hidden rust.

Other potential hidden rust issues come from the steel (or even iron) ties attaching terracotta roofing tiles to roof purlins or struts, or the interior of galvanized or roll formed steel guttering which has been blocked with vegetation or other debris for long periods of time.

Visible rust can also be seen in ironmongery, notably hinges, nails, and screws. In some cases, the rust may form a discolored runoff as it mixes with rainwater, and it stains the surface beneath.

**Fig. 18** Corroding roof valley gutter



### **6.7 Fungal, Plant, and Animal Impacts**

Timber, whether naturally resistant or chemically treated with preservative, will rot after long periods in contact with water. Figure 19 shows the underneath of a timber deck, part of which has rotted leading to a potentially dangerous failure. While readily visible from underneath, the appearance on top may not give a strong indication of the extent of the decay.

Water wicking up from the ground, particularly in the absence of either (or both) a damp proof course or adequate ventilation, can lead to rot. Figure 20 shows decay in the weatherboards closest to the ground. The only solution is complete replacement, possibly of the hidden structural timber as well as the cladding.

The decay of timber is a natural process. Over long periods of time, other natural processes have developed to convert timber into other forms. New Zealand's native

**Fig. 19** External deck timber decay



**Fig. 20** Weatherboard decay probably due to ground moisture



borer has a similar impact to woodworms found in other countries. The flying insect lays its eggs inside timber, originally native timbers, but it adapted well to imported exotic timber. When the eggs hatch, the grub bores its way to the surface before starting the cycle again (BRANZ Ltd 2000; New Zealand Technical Correspondence Institute 1980). Figure 21 shows the lighter colored “frass” which has fallen from the grubs’ flight holes.

In addition to disfiguring the surface with small holes, if the surface is removed the passageways are exposed as shown in Fig. 22. This later problem is most commonly seen in timber floors which have been exposed by the removal of carpet or linoleum, sanded and then polished. The problem is unlikely to increase, as the borer is long gone.

**Fig. 21** Borer “frass” falling down the side of subfloor joists



**Fig. 22** Insect damage revealed by floor sanding



### 6.8 Asbestos

Asbestos sheet was first advertised in New Zealand in 1907, and take-up was sufficient that it appeared in the 1921 Census where 466 dwellings reported asbestos wall cladding (out of 260,229 dwellings in total), with the big increase in use occurring post-WWII with 21,163 dwellings in 1951 (494,012 total dwellings) using asbestos sheet alone or in combination with other materials. The numbers grew steadily to 72,319 dwellings in 1976, but the material was dropped in the 1981 census, apparently replaced by the term “board” (Isaacs 2015). It is possible that the census numbers underestimate the use of asbestos, as a householder not knowledgeable about the wall construction material could easily report it as being a proprietary wallboard (Census and Statistics Office 1931). Local manufacture stopped in 1983.

Table 3 tabulates the presence of asbestos detected by the inspection. Asbestos was not found in just under two-thirds (62 %) of the houses, with the remaining (36 %) of the inspected houses having asbestos in the wall cladding. Only one house was found with the potential for asbestos in both the wall and the roof materials. Where the material is only suspected as being asbestos, generally in houses built around the 1980s, then a laboratory report is suggested.

**Table 3** Indication of the presence of asbestos

Asbestos present	Count	%
Roof and wall	1	1
Roof only	–	0
Cladding only	25	36
Neither or no data	43	62
Total	69	100

## 6.9 Movement

Four types of movement are commonly observed—differential expansion, movement of natural materials, house movement, and cracks in monolithic cladding. These may be due to the initial design, the materials, or a lack of maintenance.

Differential expansion of glass and the surrounding aluminum frame, coupled with UV degradation, has led over a long period of time to movement of the seal between the two, potentially allowing water to enter, as shown in Fig. 23. While initially this may be a simple maintenance problem (the seal needs to be pushed back into place), over time the deteriorated seal may require replacement.

Figure 24 shows a similar type of maintenance problem in a timber frame window. Timber responds to moisture by dimensional changes. A protective layer of paint acts to limit moisture ingress as well as protecting against degradation due

**Fig. 23** Aluminum window frame rubber seal has moved



**Fig. 24** Poor timber joinery maintenance



to UV, wind, salt, etc. Where maintenance has been deferred or ignored, cracks between the timber pieces can open or the putty holding the glass in place can fail. An early repair can minimize costs, but eventually, the failure can reach a level where the only solution is complete replacement of the joinery.

Wind and/or seismic movement can lead to cracks such as shown in Fig. 25, where the support for a simply supported beam has been under stress.

Monolithic claddings, in Fig. 26, often covered with a textured plaster finish, are not truly monolithic—they consist of large sheets of material which are often just butt-jointed with the joint covered over. Cracks will nearly always appear at the weak points, almost always the joint, so it is these points that special attention should be paid to detect cracking which can allow moisture to penetrate.

Monolithic cladding systems were promoted as being low maintenance, providing a sealed and waterproof outer skin, but their correct installation requires

**Fig. 25** Cracks due to movement and inadequate beam support



**Fig. 26** Crack in monolithic cladding allows water ingress





knowledge and skill not just of the material but also the use of flashings and the conditions likely to be created behind the panels. Over the 1990s to early 2000s, this led to the so-called leaky buildings problem. Large numbers of houses and apartments built during this time are expected to require significant investment to correct the problem (Hunn et al. 2002). This part of the inspection can be essential for the inexperienced purchaser.

## 6.10 Electrical

Exposed wiring is an obvious safety problem, particularly if at a height able to be readily accessed or in a moisture area, as illustrated in Fig. 27 which shows a cupboard light.

Other electrical problems are often hidden. Wiring is normally protected by switch or plug covers, but at the switchboard, it may be visible. Before plastic insulation was used for conductors, the most common insulating material for general purpose wiring was vulcanized rubber insulation (VRI or VIR) with a proofed, colored, braided, cotton covering. The cable was enclosed in conduit or wood casing for mechanical protection (New Zealand Technical Correspondence Institute 1981). Tough rubber-sheathed (TRS) cable was followed, but by the mid-1950s, this had largely been replaced with tough plastic-sheathed (TPS) or PVC-insulated cable.

The insulation on the VIR or TRS cables tends to degrade, becoming fragile and brittle, especially when near to heat. This tends to be in switches or fuse boards, with the consequence that when movement occurs (e.g., opening the fuse board for inspection) the insulation can fall off, leaving live cables exposed and able to spark, with the potential for fire.

Fig. 27 Exposed live wiring



**Fig. 28** Three generations of wiring insulation—only one is safe



Figure 28 shows a close-up of an electrical switchboard in an older house with three generations of electrical cable visible. The older rubber-insulated cables need to be replaced to reduce the risk of fire.

## 7 Conclusions

This chapter has described some common problems found as the result of pre-purchase inspections of some 700 houses, supported by statistical analysis of a subsample of 70 house reports. Although these are not a random selection and, therefore, are not a representative sample of the New Zealand housing stock, they provide a view into a wide range of house types, materials, and ages.

Each inspection involves about 4 h of on-site work for an experienced assessor, using a range of specialist measurement tools, and ensuring that inspection covers obvious as well as more hidden areas of the dwelling. This results in a report from 40 to 50 pages with photographic evidence which provides independent advice to purchasers, real estate agents, and lenders.

The styles of construction may not be found in the same proportions in other countries, but the types of building failures are likely to be common. The wide range of potential problems, whether due to adverse exterior events (e.g., heavy rainfall) or to householder activities (e.g., do-it-yourself modifications), can be due to actions around the design and construction processes (e.g., lack of a flashing), while in others they are an unforeseen consequence of the occupants (e.g., a gardener building up the earth bed outside the house and blocking the subfloor vents). In almost all cases, the issue and consequential failure could have been stopped but for a lack of basic building science knowledge or understanding.

Buildings are generally designed to limit the entrance of water, yet the protection is not always against all potential sources or designed to manage the entrance and

exit of the water. Subfloor moisture may be due to external events (e.g., flood), from beneath the building (e.g., evaporating ground water), from inside the building (e.g., disconnected drainage pipe or undetected overflow), or outside the building (e.g., block subfloor vent or blocked drainage).

When inadequate fixings are provided during construction, earthquake damage can result sometime later when houses fail off their piles. However, “do-it-yourself” owners or occupiers can create their own problems through undermining foundations to provide extra storage or space.

Given the high proportion of timber-framed structure systems with a cladding (weatherboard, fiber board, EIF, or brick veneer), the excessively high levels of moisture found are of great concern. The hidden consequences of high moisture and ultimately rot may lead to expensive restoration work at some point in the future. Similar concerns must be associated with the high levels of subfloor moisture that have been found.

Asbestos is an ongoing problem, with many in the building industry suffering from their once unprotected handling of products incorporating this material. Over a third (36 %) of the analyzed houses had indications of asbestos cladding. It is most likely that the house occupants had little or no idea of the potentially hazardous cladding, and would be likely, if undertaking their own maintenance, to expose themselves to an unnecessary hazard.

House maintenance is an ongoing requirement, often overlooked by occupants or owners. The simple act of regularly cleaning drains and gutters can mean that when it rains, the water does not get forced into areas it should not be present. While this may not be an immediate problem, in the medium-to-longer term, it can result in decay or corrosions which can ultimately lead to failure.

Timber in particular requires close observation to ensure that rot and decay can be detected and dealt with promptly. Over time, the moisture may lead to increase areas of decay and consequently increased costs of repair. This can be a particular issue with deck flooring and joints and external wallboards. Ongoing high levels of moisture can lead to making the timber more attractive to insects and fungal attack.

Although water and sewerage utilities have been dealt with in terms of their potential for moisture, electric supply needs to also be monitored. Cables can deteriorate with age, and poor installation practices can leave dangerous situations. These need require checks, although in most houses, action is seldom required.

Movement, whether due to temperature, earthquakes, wind, or day-to-day activity, can lead to other problems. In many cases, these can be managed by regular checking and maintenance.

Just over one-fifth (21 %) of the houses could be considered to be in excellent condition. Given that when a house is being sold, the seller wishes to present it in the most positive light, this would suggest there is a very large, currently unmet, requirement for house maintenance work. Many of the identified issues would not necessarily be visible either to the occupant, seller, or potential purchaser, suggesting they could easily continue until a major, or even catastrophic, failure occurred.

Whether the market actually desires this maintenance is a very difficult question. How can a house owner lacking in building management expertise be expected to know that their house requires critical work? Paint flaking off window sills or weatherboards may be obvious, but a high level of subfloor moisture can only be detected by a reasonably close inspection and ideally with suitable tools—and the majority of house occupants are unlikely to wish to spend time crawling beneath their houses and certainly lack the appropriate tools.

This lack of house owner and occupant knowledge suggests there would be benefits from requiring they be provided with a maintenance schedule for their house, similar to a car handbook. This would detail a scheduled maintenance regime of what needs to be looked at, when it should be looked at, how to undertake the inspection, and what action to take if there is a possible failure.

The identification of problems is a first step to their resolution. Future analysis of this database, along with other research exploring the condition of New Zealand houses, will help to lead not only to improved durability of the houses but also create an improved environment for living.

**Acknowledgments** We would like to acknowledge both the inspectors who undertook, and the home owners and purchasers who commissioned the analyzed inspections.

## References

- Andrews S (2002) Mold: a growing concern. *Prof Build* 67:107–108
- BRANZ Ltd (2000) Wood boring insects. BRANZ, Judgeford
- Census and Statistics Office (1931) Population census, 1926. vol XIII. Number and description of dwellings. Government Printer, Wellington
- Clark SJ (2000) New Zealand 2000 house condition survey. BRANZ, Porirua
- Clark SJ (2005) New Zealand 2005 house condition survey. BRANZ, Porirua
- Government of New Zealand (1991) Building Act 1991
- Hunn D, Bond I, Kernohan D (2002) Report of the overview group on the weathertightness of buildings to the building industry authority
- Isaacs NP (2015) Making the New Zealand House 1792–1982. Doctoral thesis. PhD, Victoria University of Wellington
- Lee N (2011) Concrete basics. *BUILD* 50–51
- Lstiburek J (2002) Moisture control for buildings. *ASHRAE J* 44:36–41
- New Zealand Technical Correspondence Institute (1980) Carpentry. Government Printer, Wellington
- New Zealand Technical Correspondence Institute (1981) Electrical theory and practice. Government Printer, Wellington
- Page IC (1995) New Zealand house condition survey, 1994. BRANZ, Porirua
- Pringle T (2010) Strengthening piled foundations. *BUILD* 31–32
- Saville-Smith K, Jowett JH, Jones MS et al (2011) Preliminary BRANZ 2010 house condition survey report. BRANZ, Porirua

# Experience from Using Prefabricated Elements for Adding Insulation and Upgrading of External Façades

K. Mjörnell

**Abstract** At present, there are a number of rational prefabricated systems on the market for adding insulation and upgrading exterior walls and façades. A number of such systems were tested and evaluated by Swedish housing companies. This process showed that none of the solutions are fully developed and that, during the projects that were studied, much of the development work took place during the renovation project. The weak points of the systems were generally found to be the connections between the elements and the existing façade, and details such as windows. In several cases, the housing companies had problems with a lack of clarity regarding responsibilities, between those who were to deliver the system and those who were to install it, as well as the division of responsibility for connection and details, such as between a window and the existing building. It is crucial that such issues are solved before a system is designed, produced, and installed. There were also problems with inaccuracies in the measurements of the existing building, which meant that both internal and external adjustments of the prefabricated elements needed to be done at the site. The main barriers to wider adoption of the prefabricated façade systems are that few companies are willing to take total responsibility for the systems and that the systems in their current form are still more expensive than traditional additional insulation and a new façade layer. Actions to be taken in order to overcome these barriers are the further development of products and systems, as well as the change to prefabrication and an assembly on-site system. The systems must become more economically competitive, and the volume of ordered and produced façade elements must increase. Calculation models should be developed that can be used as funding frameworks to demonstrate the advantages of using such prefabricated systems.

**Keywords** Prefabricated elements • Additional insulation • Mounting

---

K. Mjörnell (✉)  
SP Technical Research Institute of Sweden, Borås, Sweden  
e-mail: kristina.mjornell@sp.se

K. Mjörnell  
Department of Building Physics, Lund University, Lund, Sweden

## 1 Introduction

The built environment is often the focus discussion in efforts to fight climate change. Activities related to the built environment constitute 40 % of the total societal energy use and a major part of the EU's greenhouse gas and carbon dioxide emissions (EeB PPP annual roadmap 2010). Considering that the building stock in Europe is being renewed at a rate of only 1–1.5 % per year, there is a large potential to carry out energy saving measures in the existing building stock (BPIE 2011). These facts have pushed Europe to take actions to reduce energy use and carbon dioxide emissions in the building sector and the built environment. In 2002, the European Energy Performance of Buildings Directive (EPBD) adopted a set of minimum efficiency standards for both new and existing residential and commercial buildings (Directive 2002/91/EC). In 2009, a recast and strengthened directive (Directive 2010/31/EU) stated that all new and renovated buildings must comply with tough energy performance standards and supply a significant share of their energy requirements from renewable sources after 2020. The European directive states that “major renovations must increase energy savings if doing so is technically, functionally and economically feasible”. Thus, upcoming strengthened EU directives and national regulations will put pressure on property managers and owners to take action. Due to the age distribution of the building stock and related refurbishment needs, construction activities are increasing in the field of maintenance, renovation, and transformation.

The need for extensive renovation is not only because the buildings are worn but also due to increasing costs for energy use and environmental concerns. Development has also been made in view of the properties functionality including social and cultural aspects as well as infrastructure and service in the areas. In recent years, sharper targets lead to more ambitious energy efficiency requirements which often mean a need for more extensive renovation of the building envelope including measures such as better insulation, increased air tightness, new windows, and replacement or installation of new heating and ventilation systems where new energy sources will be considered. Developers and operators have requirements to reduce energy use both in order to fulfil energy goals from authorities and to reduce the costs of heating and operation of the buildings. However, it is important to carry out the most optimal actions to achieve cost-effective energy use while maintaining good indoor environment without sacrificing the architectural quality or cause environmental impact. Clients often do not have enough either time or knowledge to make a proper evaluation of the various renovation options before making a final decision. An important factor is that the cost of renovation is often calculated to repay in a short time rather than taking into account life cycle costs even though a thoughtful, comprehensive renovation is often more cost-effective in the long run.

Many pilot projects both in Sweden and elsewhere in Europe show that it is possible to apply additional insulation to buildings and lower energy consumption considerably. Additional insulation is applied in combination with the replacement of heating and ventilation systems. Renovation without the need to remove tenants

from their home is possible with many systems that are already on the market, and these have been used in projects in Europe. Most projects with extensive renovation are costly and have long payback periods. In order to lower costs, some pilot projects have applied a high level of prefabrication, which, however, requires a certain amount of customisation at the building site. Many companies do not view energy efficiency measures as profitable. But profitability depends to a large extent on how calculations are made and how costs are allocated between general maintenance and actual energy measures.

At present, there are a number of rational prefabricated systems on the market for adding insulation and upgrading exterior walls and façades. The modules can be vertical, horizontal, or only surrounding the area around the window such as the Swiss F 4.1 module (René et al. 2011), but there are also large size prefabricated façade modules with framework of wood studs such as TES energy façade and gap solution GmbH (Zimmerman 2012), steel studs such as Eco Elementum, (Martinsson 2012), and concrete sandwich structure such as Soleed (Mjörnell and Blomsterberg 2014). Different types of insulation are used in the elements such as cellular plastic, mineral wool, cellulose, or vacuum insulation panels. The outer surface of the façade is often flexible in terms of materials such as plates, tiles, wood, glass, or even bricks and may be rendering, depending on the architectural requirements. Most elements are self-supporting and rest on a ground plinth constructed outside the existing foundation but are fixed to the existing wall structure to manage the wind load. The systems have been applied in pilot projects in different climates, such as the gap solution GmbH in Graz and Linz, Austria, the TES solution in Oulu, Finland, and Grüntenstraße in Augsburg, Germany, and Roosendaal, the Netherlands. A number of prefabricated systems and the demonstration of these systems in pilot projects are described in project summary reports, from ECBCS Annex 50 (Zimmerman 2012) and from European projects E2Rebuild, SESBE, and SQUARE funded within FP7 and Intelligent Energy Europe.

In the last few years, several functionalities such as ventilation pipes, energy harvesting (photovoltaics and solar heating collectors), and distribution have been integrated in the modules. These are called multifunctional facades. Many research and innovation projects have developed and demonstrated prefabricated, cost-effective multifunctional façade elements for renovation and have reported state of the art including technical functionalities, specifications, performance indicators, requirements of societal aspects for a successful and beneficial implementation, design guidelines for an architecturally attractive design, and success criteria for market implementation. One such project is RetroKit, another European project funded within FP7.

The aim of the work presented in this chapter was to support the development of several approaches for the rational additional insulation of external walls and façades for existing apartment buildings, and to find a number of conceptual solutions that could be produced and assembled in a rational way. The façade solutions were also to be cost-effective, have a low environmental impact from a life cycle perspective, and be durable, which means little need for maintenance and low risk of damage. The goal was also to demonstrate that the new concept

solutions worked in full scale. Two different systems based on prefabricated elements were tested and evaluated by two Swedish housing companies.

## **2 Performance Requirements for Prefabricated Systems**

A few years ago, a group of experts and housing owners in Sweden decided to invite system providers to participate in technology procurement for rational additional insulation of external walls and façades for existing apartment buildings with the aim to find a number of conceptual solutions that could be produced and assembled in a rational way.

Together, the group formulated requirements for thermal comfort, durability, energy performance, economics, architectural quality, and other factors as a basis for technology procurement of rational solutions for improved energy performance (insulation and air tightness) in the outer walls and façades of existing multifamily dwellings, published in 2011 (Mjörnell 2012a, 2012b). These requirements are quite general and may be used for any procurement of prefabricated façade elements for renovation. In the following, the requirements concerning performance and aesthetical quality are presented. The requirements for cost accounting and tenderer's organisation are too specific and not included in this chapter.

### ***2.1 General***

The requirements are divided into absolute requirements ("must" requirements), which must be satisfied, and desirable options and features ("should" requirements), which although not absolute, could favourably affect the evaluation of a tender. Applicable requirements according to planning and building regulations and regulations in force, such as fire proofing, strength, and stability, must also be fulfilled. In the following sections, examples of the "must" requirements are described.

### ***2.2 Requirements for Functions and Durability***

The designs (existing and new) must not be exposed to dampness, where there is a risk of damp and mould damage. Components at connection, abutments, and joints should be shown on the drawing or shown by some other means so that it is possible to assess the rain tightness.



The rain tightness will be assessed on façades that qualify highly on first assessment. Assessment will be according to the SP method 4367 procedure B with pressure difference 0–600 Pa and SS EN 12865. The system will be installed by the supplier on an existing wall about  $3 \times 3$  m with a number of abutment components such as windows.

Moisture calculation according to EN 15026 or similar must be carried out and presented. When calculating, the extreme annual climate and inward leakage of 1 % of pelting rain must be used as input data.

Moisture safety design must be conducted. All materials used in new and existing parts of a design must cope with the expected moisture loading.

### ***2.3 Requirements Concerning the Indoor Environment***

The indoor environment in the housing is very important for the comfort and well-being of the residents. Therefore, a number of requirements concerning thermal comfort, light, and moisture safety are called for.

Thermal comfort

- Operating temperature must not be below 18 °C, not above 24 °C long term, and not above 26 °C short term.
- Difference in operating temperature is to be measured vertically 0.1 and 1.1 m above floor.

Light

- The glazed area must not be reduced.
- Daylight transmittance must not be lower than 63 %.
- Light conduction values in the apartment must not be seriously affected.

Moisture safety

- ByggaF, a methodology to include moisture safety in the building process, is to be used in the renovation process. A moisture expert with diploma must be engaged (Mjörnell 2014).

### ***2.4 Component Requirements***

Built-in products must meet the BASTA criteria to the stated extent. This can be confirmed if the products are entered in the BASTA register or documented otherwise in an authentic manner. BASTA is a freely available and scientifically based system with the purpose to phase out substances of concern from building and construction products. The system contains more than 90,000 products.

## ***2.5 Requirements as to Energy Performance for Parts of Buildings***

The building's energy demand for heating (premises and domestic hot water) should be calculated by means of VIP energy<sup>®</sup> or, if this is not possible, with a similar dynamic energy calculation program, and presented as kWh/(m<sup>2</sup> A<sub>temp</sub>, year).

- U-average (including thermal bridges) for outside walls, including existing walls and foundations above ground but excluding windows, must be equal or less than 0.15 W/K, m<sup>2</sup>.
- U-value of windows concerning frame with external measurements must be 1.2 × 1.2 m: 1.2 W/K, m<sup>2</sup>.
- Air tightness of outside walls, including existing walls, and foundations above ground, including windows, must be 0.5 l/m<sup>2</sup>, s. Measurements are made according to the method ISO 9972:2015, but air leakage is to be calculated per the apartment's outfacing area that makes up the thermal envelope. Outfacing areas that make up the thermal envelope are defined here as all areas that border on outside or cold spaces such as outside walls, ceilings facing the roof or a cold loft (if on the top floor), and floors on slabs on the ground or cellar (if on the bottom floor).

## ***2.6 Requirements Concerning Care for Existing Buildings***

The choice of materials must be in harmony with the relevant property and the approach adopted. Therefore, a number of requirements concerning architectural qualities are formulated such as:

- Components must be made with architectural qualities.
- Component abutments façade/window, façade ceiling, façade/base, entrance, and entrance hall must be carefully and deliberately designed. New façade compositions must have architectural and formational quality.
- The property's architectural and formational quality must be unchanged (or improved) in their entirety after additions.

## ***2.7 Requirements as to Operating and Maintenance Instructions***

The operation and maintenance of the building components are of crucial importance for the function and durability.

- Operating and maintenance instructions must be compiled and show what is needed to maintain the intended function and useful life (state scope and interval).
- Operating and maintenance instructions must be handed over to operating staff before the building is used.

## ***2.8 Requirements Concerning Consideration for Residents***

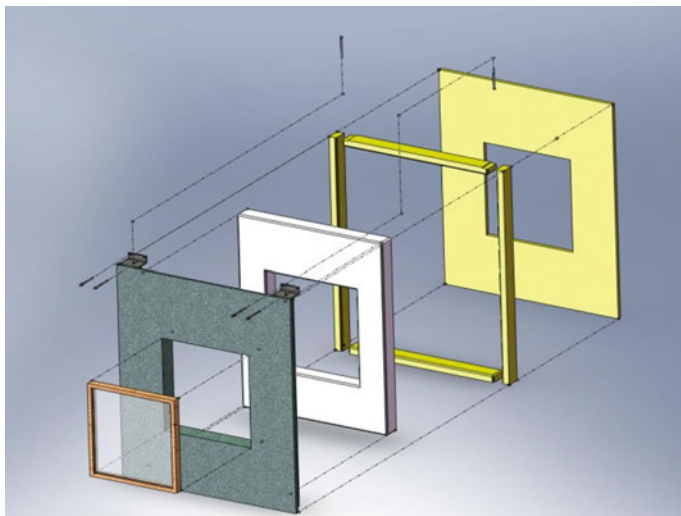
Since renovation works intrude on the everyday life of residents, especially if the residents remain in the buildings during renovation, special care must be taken to inform the residents of the planned work and also to communicate with them during the ongoing renovation process.

- The supplier must provide information material and must be available for information meetings with residents.
- The supplier must describe the building process, including installation, the work environment, and logistics.
- The time to be taken for building work on site must be stated.
- The requirements for execution and installation in the façade must be described.
- Reconstruction must not cause marked disturbance for residents. The supplier must state to what extent residents can remain in the buildings during renovation or if they have to move to evacuation apartments.

## **3 Examples of Two Types of Prefabricated Systems**

### ***3.1 System A***

System A is a construction and renovation system, consisting of prefabricated elements moulded in a box construction of thin slab of high-strength ceramic concrete, combined with moulded cellular plastic insulation and a layer of mineral wool. The reduction of thickness and weight is attributed to the use of fibre reinforced reactive powder concrete (FRRPC), which has a four to five times higher mechanical strength than standard reinforced concrete. This new prefabricated element is a lightweight half panel aimed for renovation of existing buildings. The outer surface could be inked or painted concrete. Before the design and manufacture of building blocks begin, there will be a survey of the existing façade by 3D laser scanning to detect irregularities of the surface so that errors in the on-site assembly site will be minimised. The elements are either fabricated with pre-assembled windows, or the windows may be mounted at the building site. The elements are mounted directly on the old façade surface since the soft layer of mineral wool on the back of the elements may compensate for some of the unevenness, (Mjörnell and Blomsterberg 2014).



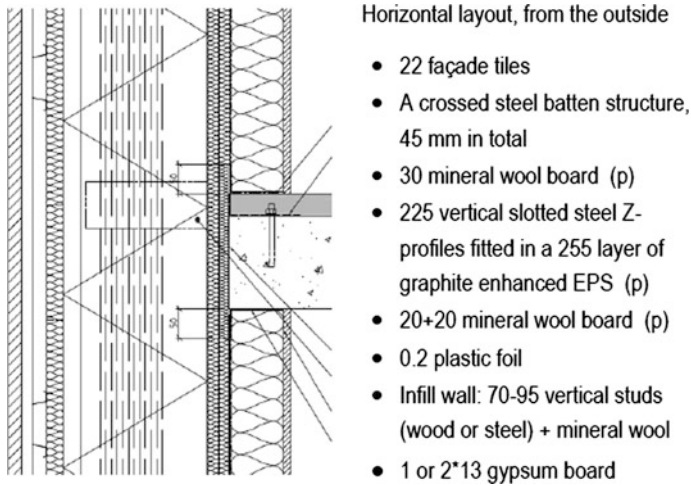
**Fig. 1** Construction and renovation system consisting of prefabricated elements moulded in a box construction of high-strength concrete combined with moulded insulation, System A

As the façade elements are self-supporting, it is also possible to place the first elements on a ground plinth and pile up the other elements on top, without loading the existing structure. However, some means of attachment to the existing wall to take up the wind load is needed. Elements are normally fitted with a crane, aerial platform, or the equivalent, but one of this is needed. This radically reduces lead times for the insulation of the façade. When the element is in place, existing windows will be removed from inside and the connections to the new window corrected. The work can usually be done with minimal disruption to residents, allowing them to stay in the apartments during renovation (Fig. 1).

### 3.2 System B

System B consists of prefabricated elements mounted directly on an existing infill wall or to an existing concrete wall, or as a new curtain wall on the framework as a replacement for the existing wall dismantled. The elements are self-supporting and stand on its' own ground plinth. Only wind loads are transferred to the floors where the elements are fastened into the frame. This makes it possible to mount the elements on slender frames without loading them further. The elements can be made as high as the building. The wall elements are manufactured to fit each specific part of the building regarding width, height, and thickness.

The wall elements so-called primary layer consist of slotted steel studs with Z profiles in combination with a contour cut graphite foam insulation. The elements



**Fig. 2** Design of the wall element System B. Picture from Martinsson (2012)

are very stable and moisture proof. The primary layer is on the inside and outside area covered with a fire-resistant layer of mineral wool board. The total thickness of the wall element is 500 mm. The elements can if necessary be supplied with premounted exterior facade battens for fixing the exterior façade layer which could be of plates or tiles. The distance and the thickness of the steel studs are adapted to the current building’s load conditions and to the size and location of windows and other openings. Window can be fitted into the elements at the factory or installed in the wall elements afterwards (Fig. 2).

Development of the elements was done in close collaboration between the contractor and the system supplier, and feedback has continuously been obtained from the craftsmen and production manager. Critical moments and details have been identified. Pilot elements have been constructed and tested to verify functions, mounting procedures, tolerances, choice of materials and components, etc., and modules have been constructed for full-scale testing of fire resistance and driving rain tightness.

#### 4 Evaluation of Specified Requirements in Laboratory

The process for the evaluation of specific technical requirements was as follows:

Step 1: Evaluation of the technical documentation received by the system provider. This evaluation would be based on the requirements specification.

Step 2: Laboratory testing of selected tender proposals for the evaluation of the requirements regarding rain tightness.

Step 3: Evaluation of complete system solutions installed on a demonstration building in situ. This evaluation would be performed on the basis of measurements

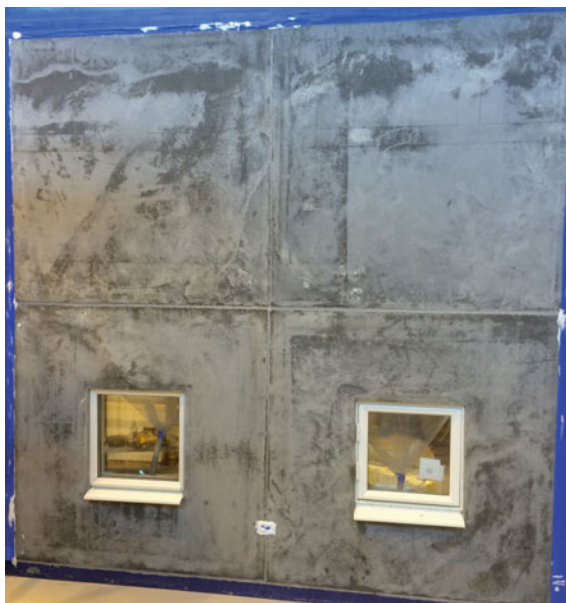
taken over a year according to a measurement program for evaluation, as well as on verification of the “must” and “should” requirements.

#### ***4.1 Evaluation of Rain Tightness Through Testing***

Tightness against driving rain was performed according to SP Method 4367 procedure B with pressure difference 0–600 Pa which is based on EN 12865. The system is installed by the client on an existing wall of about  $3 \times 3$  m, with a number of connection details, such as windows, balcony attachments, attachments to the roof, plinth, attachment of drainpipes, awnings, lighting, and expansion joints, defined in SP Method 4367.

Results from more than one hundred wind commercial driven rain laboratory tests on mock-ups of different types of facades showed that more than 90 % of tested mock-ups and nearly 50 % of the details leaked (Olsson 2014). The tests were carried out in accordance with EN 12865, with a slight modification involving 5–10 hammer blows on façade details to simulate the mechanical loading that the façade details are exposed during construction. The most frequently leaking detail was window connection, failing in more than 70 % of the tests. The results also show that the connection between joints and elements and the connection between façade and concrete slab are leaking in more than 60 % of the tests. The magnitude of leakage at one specific point is typically 0.01–0.05 l/min, at leaks invisible at first sight, (Olsson 2014) (Fig. 3).

**Fig. 3** Façade System A mounted in the test chamber for testing of driving rain tightness



## 5 Experience from Using the Prefabricated Systems on Site

Two housing companies have been able to implement additional insulation of façades using rational systems. Much of the development cost and commitment required to use a new technique were provided by the housing companies and the companies that have developed system solutions themselves (see Table 1).

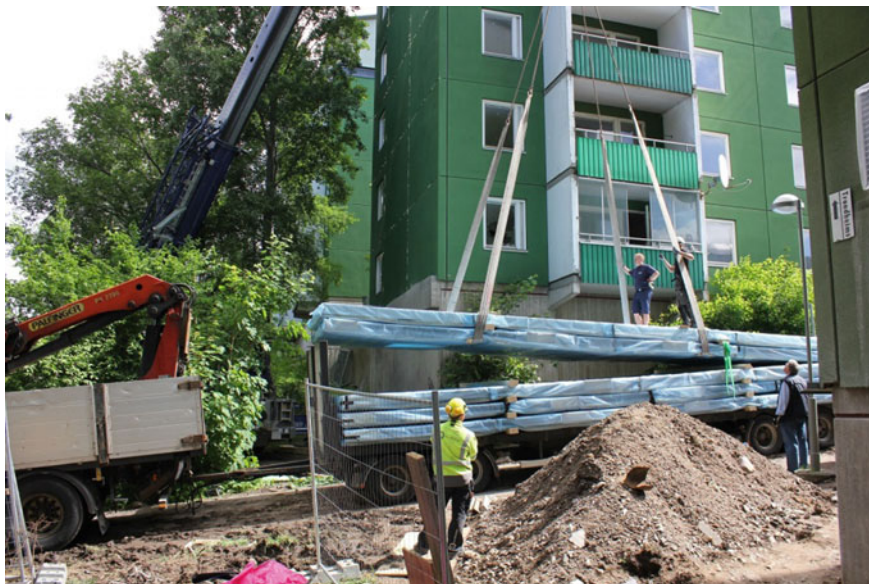
### 5.1 *The Trondheim Block, Owned by Svenska Bostäder*

Svenska Bostäder had an agreement with the City of Stockholm's Environment and Health Administration concerning energy efficiency in renovation and usage of renewable energy in seven projects, incorporating a total of 350 apartments, during the period 2009–2014. Part of the agreement was to examine and compare a prefabricated solution to traditional plaster for additional insulation, and Svenska Bostäder decided to use System A. The installed façade has near-invisible joints, and the elements have a surface texture similar to plaster. The system consists of light elements, which is an advantage in terms of both installation and transportation. The prefabricated wall permits tenants to remain in the apartments during renovation (Fig. 4).

However, some problems occurred with the on-site coordination, such as the fact that the crane was new and did not work, meaning that, after the lifting of the first element, there was a break of two days. There were also problems with deliveries. The prefabricated system remains expensive when compared to traditional plaster and insulation. Some inaccuracies in the measuring of the existing building and an unforeseen concrete detail holding the old window in place meant that adjustments were needed inside the window openings. The provision of sheeting was not coordinated between the system supplier and contractor. Some plastering and painting work were required in the joint between the precast elements and the existing façade. The reason for these deviations is probably that the product was not fully developed and had not previously been tested in a real renovation of a whole

**Table 1** Systems used in the pilot projects

Pilot project	Housing company	System used
One façade at a multifamily building in the Trondheim block in Järva, Sweden	Svenska Bostäder	System A
Last phase, consisting of 3 buildings out of 16 renovated buildings in Brogården, Alingsås, Sweden	AB Alingsåshem	System B



**Fig. 4** Prefabricated elements arriving at the building site

building. The housing company would like to have the system supplier involved in the planning and to participate in the purchasing process for the system in competition with other system providers (Fig. 5).

## **5.2 *Brogården, Owned by AB Alingsåshem***

The primary cause of AB Alingsåshem's decision to renovate the façade was that the brick façade had disintegrated and that there were thermal bridges along the slab of the indented balconies. The results of an evaluation of various façade systems and of whether to retain some of the existing wall suggested that replacing it with a new wall and façade would be the best alternative, both from an energy standpoint and a technical point of view. Skanska Sweden AB, together with Sundolitt and Europrofil, had developed a prefabricated wall which was used for the last three buildings to be renovated in the neighbourhood of Brogården (Fig. 6).

Before the elements were produced, the concrete frame was measured in using laser scanning technique. The purpose of the measurements was to detect derivations compared to drawings and irregularities in the surface of the concrete framework where the new façade elements were to be mounted. The measurements were done when the old façade was dismantled. In Fig. 7, deviations are shown for

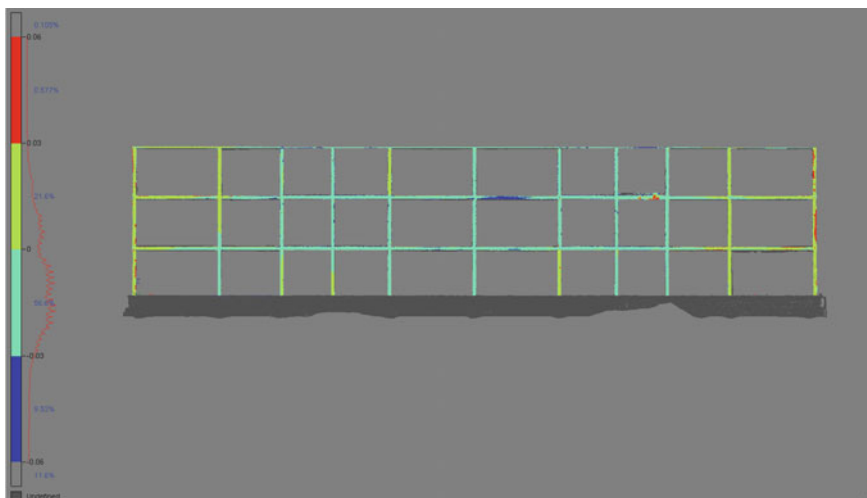




**Fig. 5** Mounting of prefabricated elements was done with crane and sky lift



**Fig. 6** The concrete frame after the old façade was dismantled



**Fig. 7** Deviations in plane measured at the framework facing the new façade

one façade. The range of colours represents the deviations from a plane where red represents protruding and blue represents intrusive parts.

The production of the elements was done inside a factory and the elements were wrapped in plastic sheeting when transported to the construction site. The time for mounting has been shortened to one week compared to six weeks before using prefabricated elements. Construction of the wall is no longer a time-critical activity, leading to shorter total time of construction. Costs for weather protections are decreased, and since the building becomes tight, the interior work may start earlier which allows a faster moving in. Decreased costs and the possibility to balance the workload are some of the positive outcomes (Fig. 8).

In Brogården, AB Alingsåshem and their partners worked on continuously improving the design and construction process and made many changes to the design and manufacturing of wall structures during the project. Three different types of wall have been developed and used, the latest of which is prefabricated and which needs to be developed further in order to be truly rational. The next step is to launch the prefabricated wall element on the market so as to increase the critical mass in terms of the number of produced elements. AB Alingsåshem will continue to work with the prefabricated wall in an upcoming project involving the renovation of approximately 700 apartments. This solution permits the tenants to remain in the apartments during renovation, provided an extensive interior renovation is not carried out at the same time, as was the case in Brogården (Fig. 9).



**Fig. 8** Mounting of the elements at one of the buildings at Brogården. *Photograph* Elementum Eco AB



**Fig. 9** Three-storey high prefabricated wall elements, mounted on one of the buildings in Brogården

## 6 Evaluation of Specific Requirements on Site

The aim of the measurements was to follow up the temperature and relative humidity in the prefabricated wall after mounting the element. In order to evaluate whether the relative humidity in the wall elements exceeded the critical relative humidity for the materials in the element, measurements were made at different positions in the wall. A number of gauges measuring and transferring data of RH and temperature were placed in the graphite insulation layer on the inside of the mineral wool layer in the wall element, as shown in Fig. 10. The outdoor climate was measured close to the entrances of the building and was protected from precipitation. The loggers are reporting data every 5 min.

A typical result from measurements of RH and temperature is shown in Fig. 11. The data shown in Fig. 11 are the average data for every hour.

The results show that the measured levels of RH and temperature are beneath the critical levels for either mould growth or corrosion of the steel studs.

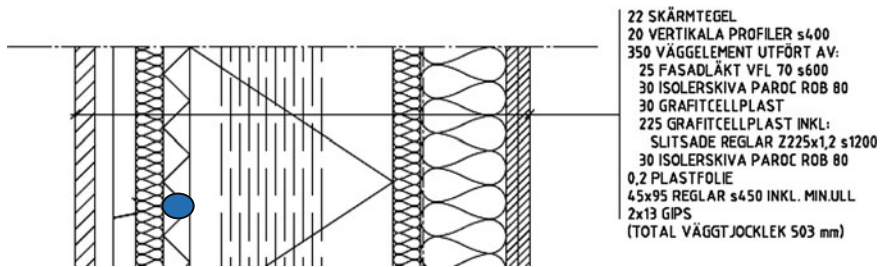


Fig. 10 Placement of gauges measuring relative humidity and temperature

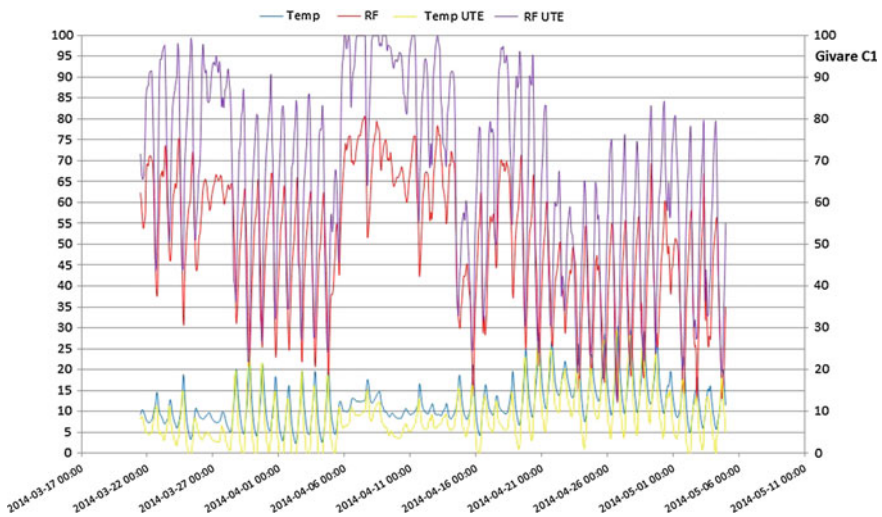


Fig. 11 An example of measured RH and temperature in the prefabricated wall element

## 7 Discussion of the Results

At present, there are many rational systems on the market for adding insulation and upgrading exterior walls and façades. However, none of the systems that were used have proved to be fully developed at the beginning of the projects, and so a large part of the development of these systems took place during the renovation projects. The weak points of the systems were generally found to be the connections between the elements and the existing façade, and details such as windows. In several cases, the housing companies had problems with a lack of clarity regarding responsibilities, between those who were to deliver the system and those who were to install it, as well as the division of responsibility for connection and details, such as between a window and the existing building. It is crucial that such issues are solved before a system is designed, produced, and installed. There were also problems with inaccuracies in the measurements of the existing building, which meant that both internal and external adjustments of the prefabricated elements needed to be done at the site. The main barriers to wider adoption of the prefabricated façade systems are that no company is willing to take total responsibility for the systems and that the systems in their current form are still more expensive than traditional additional insulation and a new façade layer. Actions to be taken in order to overcome these barriers are the further development of products and systems, as well as the change to an prefabricated and assembly on-site system. The systems must become more economically competitive, and the volume of ordered and produced façade elements must increase. Calculation models should be developed that can be used as funding frameworks to demonstrate the advantages of using prefabricated system.

In several cases, the housing companies had problems regarding the division of responsibilities among those who were delivering a system and those who were installing it, as well as in terms of connection details, for example between a window and the existing building. It is crucial that this issue is resolved before the housing company purchases the system and the installation commences. Problems also occurred with the on-site coordination; in one case, there were a number of technical problems during assembly. The limited availability of the crane led to a longer assembly time for the elements than was expected. In the case of prefabricated elements, inaccuracies in the measuring of the existing building led to the need for adjustments on-site, both externally and internally.

In one case, the company and system supplier have partnered and together developed the system during the construction period, giving good results; this has brought with some development costs, although these have been defrayed by the system supplier.

The housing companies believe that many of the prefabricated systems are still more expensive than the traditional insulation and rendering solutions. The barriers to the adoption of these systems on a larger scale mentioned by the housing owners are that no company is willing to take total responsibility for them, in terms of both manufacturing and mounting and that, in their current forms, such systems are too expensive.

To get a wider spread of the technology, the systems must become more economically competitive, and the volume of ordered and produced prefabricated façade elements must increase. In several cases, the housing companies have problems with a lack of clarity regarding responsibilities, between those who were to deliver the system and those who were to install it, as well as the division of responsibility for connection and details, such as between a window and the existing building.

It is important that all drawings are ready before the construction work begins so that there is opportunity for a collaborative review of them. A good approach is to ask the contractors to describe exactly how the work will proceed before signing contracts. One actor must take complete responsibility for the system, including mounting, connections, and joints to existing building elements. The rational systems must be proven to be economically competitive before they can compete with traditional systems. If the volume of produced rational systems increases, systems can become cheaper; a larger market, however, is needed to attain the necessary critical mass in terms of number of produced elements.

## 8 Conclusions

There are a number of prefabricated systems on the market for adding insulation and upgrading exterior walls and façades.

The weak points of the systems were generally found to be the connections between the elements and the existing façade, and details such as windows.

There are a lack of clarity regarding responsibilities, between those who deliver the system and those who install it, as well as the division of responsibility for connection and details, such as between a window and the existing building.

One company must take complete responsibility for the system, including mounting, connections, and joints to existing building elements.

The prefabricated systems must be proven to be economically competitive before they can compete with traditional systems.

If the volume of produced prefabricated systems increases, systems can become cheaper; a larger market, however, is needed to attain the necessary critical mass in terms of number of produced elements.

**Acknowledgments** The authors would like to thank the financial support BeBo through the Swedish Energy Agency and by the client group.

## References

- BPIE (2011) Europe's Buildings Under the Microscope. A Country-by-Country Review of the Energy Performance of Buildings; Building Performance Institute Europe (BPIE), Brussels, Belgium
- EC (2002) Directive 2002/91/EC of the European Parliament and of the Council of 16 December 2002 on the energy performance of buildings. Off J Eur Commun L1:65–71
- EC (2010) Directive 2010/31/EU of the European Parliament and of the Council of 19 May 2010 on the energy performance of buildings (recast). Off J Eur Union L153:40–43
- EC (2010) Energy-Efficient Buildings PPP, Multi-Annual Roadmap and Longer Term Strategy. European Commission, Brussels, Belgium
- Kobler RL, Binz A, Steinke G, Höfler K, Geier S, Aschauer J, Cousin S, Delouche P, Radelet F, Ruot B, Reynier L, Gobin P, Duforestel T, Senior G, Boulanger X, Silva P, Almeida M (2011) Retrofit Module, Design Guide, March 2011. ISBN 978-3-905594-60-7
- Martinsson L (2012) Development of energy efficient wall for retrofitting. In: Proceedings of the Passive House Norden conference, Trondheim
- Mjömell K (2012a) Technology Procurement of Rational Insulation of the Building Envelope for Existing Multi-family Buildings. Teknikupphandling: Rationell isolering av klimatskärmen på befintliga flerbostadshus, 2012. Final report (in Swedish) and procurement documentation available at: [www.bebostad.se](http://www.bebostad.se). Accessed 25 Jan 2015
- Mjömell K (2012b) Technology procurement of efficient insulation of exterior walls and façades for existing multi-family dwellings. In: IBPC, international building physics conference in Kyoto, June 2012
- Mjömell K (2014) Industry standard ByggaF Method for including moisture safety in the building process. In: 10th Nordic symposium on building physics, Lund, June 2014, pp 1164–1170
- Mjömell K, Blomsterberg Å (2014) Rational insulation of exterior walls and facades for existing multi-family buildings. In: 'Rationell isolering av ytterväggar och fasader för befintliga flerbostadshus', 'Slutrapport för utvecklingsprojektet' TURIK 2, 2014. Report (in Swedish) available at [www.bebostad.se](http://www.bebostad.se). Accessed 25 Jan 2015
- Olsson L (2014) Results from laboratory tests of wind driven rain tightness in more than 100 facades and weather barriers. In: 10th Nordic symposium on building physics, Lund, June 2014
- Zimmermann M (2012) ECBCS Annex 50 Prefabricated Systems for Low Energy Renovation of Residential Buildings. Published by AECOM Ltd. UK. [http://www.ecbcs.org/docs/ECBCS\\_Annex\\_50\\_PSR.pdf](http://www.ecbcs.org/docs/ECBCS_Annex_50_PSR.pdf). Accessed 25 Jan 2015

## Information Accessible at Web Sites

- BASTA. A freely available and scientifically based system with the purpose to phase out substances of concern from building and construction products. <http://www.bastaonline.se>. Accessed 25 Jan 2015
- ByggaF Industry standard for moisture safety in the building process. [www.fuktcentrum.se](http://www.fuktcentrum.se). Accessed 25 Jan 2015
- E2Rebuild. <http://www.e2rebuild.eu>
- ISO 9972:2015 Thermal performance of buildings—Determination of air permeability of buildings—Fan pressurization method. [www.iso.org](http://www.iso.org)
- SESBE. <http://www.sesbe.eu>
- SQUARE Quality Assurance System for Retrofitting of Multifamily Buildings. <http://www.iee-square.eu/>
- TES energy façade. <http://www.tesenergyfacade.com>

# Assessment of State-Supported Mould Renovations in Finland

Tero Marttila, Petri Annila, Paavo Kero and Jommi Suonketo

**Abstract** Moisture and mould damage in structures are causing health issues in many schools, kindergartens, hospitals and other public buildings in Finland. The Finnish Government required quality assurance procedures in a terms and conditions of the state grants that were handed out from the supplementary budgets of 2012 and 2013. Meaning of the measures was to secure successful outcome in removing the indoor air quality (IAQ) problems of the building and also to help Regional State Administrative Agencies in allocation of the grants. This research studied the benefits and impact of the process.

**Keywords** Moisture and mould damage · Indoor air quality · State grant · Condition investigation

## 1 Introduction

Tampere University of Technology (TUT) has studied state-supported mould renovations from 2010. Part 1 of the research ended in 2011. Individual part 2 concerned a supplementary allowance of 2012 and the research for that started at the end of 2012 and was finished at the spring 2014. Also individual research part 3 started in the summer of 2014 and ended in December 2015, but it concerned a supplementary allowance of 2013.

---

T. Marttila (✉) · P. Annila · P. Kero · J. Suonketo  
Department of Civil Engineering, Tampere University of Technology (TUT),  
Tampere, Finland  
e-mail: tero.marttila@tut.fi

P. Annila  
e-mail: petri.annila@tut.fi

P. Kero  
e-mail: paavo.kero@tut.fi

J. Suonketo  
e-mail: jommi.suonketo@tut.fi

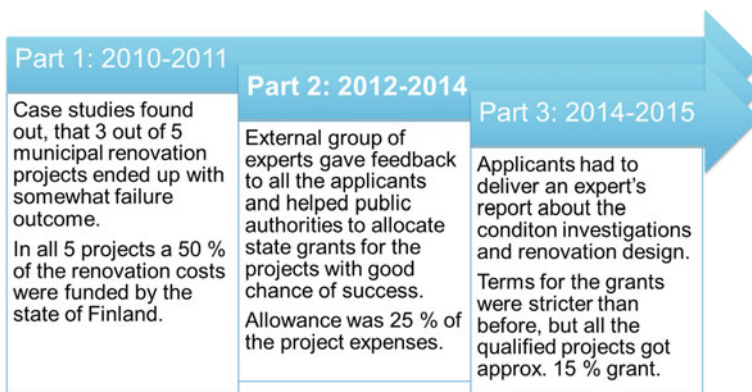


Part 4 would gather information about the outcome, quality assurance measures, and success of the same projects that were studied in part 3. That follow-up research (part 4) would be significant and necessary in order to make a comprehensive study for a large sample of projects, but funding for the study has not yet confirmed. Monitoring the success of the renovating projects is not easy task, but it is achievable (Haverinen-Shaughnessy et al. 2008). Data of this research would enable a unique possibility of study at Finnish science community, and the results and knowledge through them could have a real utility for the quality of Finnish construction industry.

This contribution focuses in parts 2 and 3 of the research, which concentrated in additional state grant procedures that were used to help Finnish municipalities to renovate buildings that are suffering from moisture and mould damage or other indoor air quality (IAQ) problems.

Part 1 of the research brought out that many renovations have failed to remove indoor air problems in municipal buildings, which causes unnecessary expenses and health problems (Kero 2011). Therefore, the terms and conditions for the state grants were developed to help the applicants to secure the success of their projects. The main goal of the research in parts 2 and 3 was to evaluate state grant procedures and recognize the needs for developing the process. Another purpose in part 3 was to build a database also for a follow-up research (part 4). Part 2 of the research examined the need and the impact of the state grant procedure of 2012 and also found out how the mould renovation project should be carried out and which factors are important in order to complete a successful renovation. Timeline of the research and some essential points about the individual parts is shown in Fig. 1.

In this book chapter, the original conference paper is extended with the results from part 3 of the research, which aimed to study the later state grant procedure that was mainly carried out in 2014. State grants were allocated from the third supplementary state allowance of 2013, and the research was mainly carried out in 2015. Most of the results are analysed, but the final research report of the part 3 is



**Fig. 1** Timeline of the research and development of the state grant procedures in Finland

not yet published at the time of writing. In this contribution, a mould renovation can also mean a project that is replacing building beyond repair or a project that has other indoor air pollutants than just mould and moisture damage. In this contribution, all the applicants for the state grant are called to municipality, even though some of the applicants were other acceptable organizations, e.g. federation of municipalities, cities, hospital districts or private schools.

## **2 Background, Reasons and Scope of the Research**

Previous study (part 1 of the research) found that many mould-related renovations have failed to remove the indoor air problems or the outcome or the management of the renovation project has been poor otherwise. Many damage could be avoided with proper maintenance and timely repairs (Kero 2011).

In 2012, Finnish government subsidized mould renovations with an extra 30 million euros. Cities, towns and other public building owners were allowed to apply for state grant. Applicants had to deliver a condition investigation report, a renovation design and other quality assurance documents. Group of experts evaluated the applications to help Regional State Administrative Agencies to allocate state grants to projects with good chance of success, i.e. good probability in removing the indoor air pollutants and other possible defects that may cause IAQ problems. Experts gave feedback to all the applicants, which helped them to improve the quality and implementation of the renovation.

Research part 2 studied benefits and impact of the external expert assessment. Another goal of the study was finding the factors of success in mould renovations. Some results from part 2 were taken into account, when the Finnish Government set a regulation about the quality assurance procedures that were used as a terms and conditions for the state grants that were handed out from the supplementary budget of 2013. Part 3 of the research concentrated to evaluate the requirements for allocating this latest supplementary allowance.

### ***2.1 State Grant Procedures for Mould Renovations in Finland***

Subsidizing the renovations of the schools has long traditions in Finland. However, the amount of the allowance has been decided in yearly basis, and it has been inadequate to help all the municipalities in renovating their buildings that are suffering from indoor air pollutants. It is not very uncommon in Finland that a health inspector has prohibited the use of a school building until the indoor air pollutants have been removed by renovation. That of course causes a lot of costs and inconvenience and forces municipalities to renovate those buildings. Therefore,

the Finnish Government has granted additional grants for renovating the buildings with indoor air problems. These additional grants have been allocated for removing indoor air problems, but not to other building projects. Some of the projects have failed to remove the problems (Kero 2011), which have meant that the grant has been a waste of money. Therefore, the allocation, terms and conditions have been made stricter than before. This research (parts 2 and 3) focuses on additional state grants and to the procedure, which has aimed to support the allocation of the grants to the projects with good chance of success.

Traditional state grant for Finnish schools was only 8 million euros in 2012, and only 8 schools were granted with 50 % allowance of the project expenses. In the beginning of 2012, the Finnish Government set additional 30 million euros for renovating and replacing municipal buildings with moisture, mould and indoor air problems. 20 million euros was allocated to schools, and 10 million euros was allocated to kindergartens and to social service and healthcare buildings. Amount of the grant was set to 15–25 % of all the acceptable project expenses. Most of the projects got 25 % grant. Grant was appropriated to 46 projects, and 21 of those were schools.

Application for the grant was submitted from approximately 180 projects. Finnish Ministry of Education and Ministry of Social Affairs and Health named a group of experts to evaluate all the applications, especially the constructional appendixes (mainly condition investigation reports). Purpose for external assessment was to help Regional State Administrative Agencies to allocate state grants to projects with good probability of removing IAQ problems of the building. Experts also gave feedback to all the applicants, which helped to improve the quality and execution of the renovation projects.

In order to get state grant on 2012, applicants had to deliver reports from comprehensive condition investigations and assurances about the quality control. External group of experts was asked to evaluate that the renovation design will remove all the moisture and indoor air problems that were found in condition investigations. Competence of the responsible foreman and supervisor was also one of the conditions to be met in order to get state grant.

The assessment group of experts was not formed for the state grant procedure of 2013. Instead of that, municipalities had to get an expert's report about the condition investigations and add it to the application. In the beginning of the construction implementation phase, another expert's report was needed regarding the renovation design. Terms and conditions, as well as contents of the application, were regulated more strictly than ever before by the Finnish Government. In 2013, the amount of the supplementary allowance was 50 million euros. 35 million euros was allocated to kindergartens and schools, and 15 million euros was allocated to social service and healthcare buildings.

Supplementary allowance of 2013 was shared with all the projects that met the terms, i.e. fulfilled the minimum content of application. Altogether, 131 projects got the grant. Those consisted of 57 schools, 35 kindergartens, 2 joint ventures (school and kindergarten in the same real estate) and 37 social service and healthcare buildings. Amount of the grant was between 10 and 15 % for schools and

kindergartens and 15 and 20 % for social service and healthcare buildings. Deadline for applications was 31 January 2014, and 222 applications were received before that. 156 applications concerned schools and kindergartens. The rest 66 applications concerned social service and healthcare buildings.

## ***2.2 Research Need and Objectives***

In 2012, Finnish Ministry of Education and Ministry of Social Affairs and Health ordered a research from TUT in order to evaluate the impact of the group of experts and the external evaluation in the process of allocating the state grants. State grants should be allocated to properly prepared projects with thoroughly considered method of implementation and therefore a good chance of success. State cannot support failing projects or unnecessary repairs any more. That was the reason for the external assessment. Part 2 of the research aimed to find out how well the external assessment actually helped the projects compared to the previous years and what were the key factors for a successful project in practice.

The scope of the research part 2 was to study not only the projects, which got a state grant, but also the projects that did not get a grant. All the applicants got feedback from the group of experts, and therefore, it was not possible to compare how the external evaluation had helped the projects with and without the external assessment. It was, however, possible to evaluate the impact of the feedback to the both groups of the applicants. Rough estimates about the success of the projects were done compared to the case studies in the part 1 of the research. In part 1 of the research, five projects were studied and three of those had somehow unsuccessful outcome (Kero 2011). All those had got a 50 % grant from the state budget of 2010.

Part 3 of the research was ordered also by Finnish Ministry of Education and Ministry of Social Affairs and Health in 2014. This part of the research aimed to find out the effect of the latest process (used for allocating the supplementary allowance of 2013) and the quality of the experts' reports. Another goal of the research in part 3 was to study the decision-making procedures and methods in the state grant allocation and especially compare the equality of the decisions between different Regional State Administrative Agencies.

## **3 Research Implementation, Methods and Data**

As described in the previous section of this contribution, research has been carried out in three individual parts so far and the research team's focus is already in fourth part. This contribution, i.e. chapter in the ISBP2015 book, concentrates to parts 2 and 3 of the research, where the first author has conducted the main part of the project implementation, but all the other writers have been part of it as well.

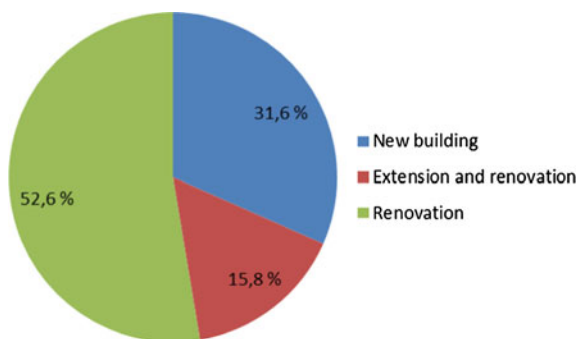
### 3.1 Part 2 of the Research

In part 2 of the research, all the 180 applicants were invited to take part in the questionnaire on the Internet. Questionnaire received 57 responses, which means that approximately one-third of the applicants filled in the questionnaire. Response rate was expected. Approximately, half of the responses concerned the projects, which had got a state grant. The other half gave important data from the projects that did not get a state grant. As shown in Fig. 2, more than half of the responses concerned renovation projects. Almost 32 % of the responses concerned the projects, where a new building was replacing an old building with severe moisture damage or otherwise beyond cost-effective repairing. Approximately, 16 % of the responses concerned the projects, where a part of the building was repaired and another part of the building was either replaced with a new extension or just extended without demolition of any parts of the old building.

Ten projects were selected in the closer case studies. All the selected projects had got a state grant and the sample concentrated mainly to the renovation of the schools, because that group was the main target of the research. Otherwise, the sample selection was made as extensive as possible. Sample included big and small projects from all around Finland. Eight case projects were pure renovations, but varied with the method of renovation and with the phase of the implementation (at the moment of the interview). Only one project was entirely replacing the old building. One project had got the grant for replacing a part of the old building, but other part was planned to renovate. Sample consisted of two hospitals, one kindergarten and seven schools. The oldest included building in the case studies was built in 1928 and the youngest in 1987. Nine of these building projects were visited to make observations at the construction site. One project did not get a contractor, and the project was postponed and therefore not visited.

Project manager from every case project was interviewed. One of the main purposes for the case studies was to find out possible changes in the renovation design and other reactions to the sudden discoveries while destructing the old structures and this

**Fig. 2** Contribution between implementation methods in the questionnaire responses



way evaluate the success of the project. Another main objective was to ask project managers' opinions and experiences about the external assessment and about the state grant procedure. Also three out of four members of the assessment group of experts and 5 officials of Regional State Administrative Agencies were interviewed. This way, the survey covered three points of view in the same subject. Altogether, 18 persons were interviewed. Interviews were seen as the main source of the most important information in part 2 of the research.

Implementation of the research part 2 was conducted mainly as a Master's thesis (Marttila 2014) by the first writer of this contribution. Therefore, the research also included a significant part of literature survey. Some application appendixes from the projects that did not get a state grant was also evaluated for making observations about that group of projects too.

### ***3.2 Part 3 of the Research***

Part 3 of the research concentrated more in the evaluation of application appendixes than part 2. Objective was to gather data from a significantly large sample. More than 200 municipalities were asked to send data from their projects. In particular, the experts' reports were analysed with the numeric scale. Criteria for the evaluating was based on the terms and conditions of application, which were set by the Finnish Government with the regulation. Scale was carefully selected for every individual aspect of evaluation.

Also questionnaires were carried out in part 3 of the research. Short questionnaire, with possibility to open answers, was send to all the Regional State Administrative Agencies that were handling the state grant applications. Applications were handled in nine different offices, and the questionnaire got six responses. Geologically, the responses were divided between every administrative region of Finland. Three respondents had been dealing with school building projects and three respondents with other municipal building projects, i.e. social affair or health-related public buildings. Results from another questionnaire are not yet analysed. This questionnaire was conducted by National Public Health Institute, and only 5 questions were concerning specifically the target of this research.

Most of the building projects did not finish during the active study of the research part 3, and therefore, it was not possible to gain information about the actual success of the projects, but this would be a main goal in part 4 of the research. Data for part 3 of the research have been collected with the follow-up research (part 4) in mind. Information about the control measurements of the projects would be gathered in part 4 and compared to the findings of the condition investigations and other project preparations. This way it would be possible to estimate the success of the projects and true impact of the preparations that were guided with the latest additional state grant procedure.

## 4 Findings

One of the key findings in the research part 2 was that the renovation designs, hydrothermal behaviour of the new structures and quality assurance documents should be inspected by an external consultant, e.g. condition investigator. Purpose for this is to make sure that the designed repairs will remove all the problems that are found with the comprehensive condition investigations. Everybody from investigator and builder to structural engineer, contractor and construction supervisor must have competence and preferably certificate for moisture damage repairing. Part 3 of the research studied the impact of the measures mentioned above by interviews and by analysing the quality of the documents and other measures that were required and set by regulation by the Finnish Government for the supplementary allowance of 2013. Report from part 3 is not yet published, and therefore, only some of the results are presented in this contribution.

Another central target for the study in both, part 2 and part 3, of the research was the additional state grant procedures. Municipalities have seen the terms and conditions of application as a good way to improve the quality of the projects, even though they have been unfamiliar with the new procedures. Ignorance about the details of the requirements combined with a tight schedule and some inaccuracy in the term and conditions caused quite a lot shortcoming in applications, but this dilemma and proposals for development are discussed more closely in the next section of this contribution.

### *4.1 Factors of Success in Mould Renovation Projects*

Factors of success in mould renovations were identified in part 2 of the research. Those factors are presented in Fig. 3. The key findings of the research part 2 are emphasized with bold text type in the same figure. Interviews in part 2 especially brought out the importance of the comprehensive condition investigations of all structures, building service systems and other building components. Not just the first and obvious one, but also all the hidden indoor air pollutants must be found and removed. Old buildings usually have more than one fault causing the health problems to the users.

Common example is a moisture damage hidden inside the lower part of the wall and non-air-proof joint combined to the incorrect adjustment of the ventilation system. Another common health problem arises from volatile organic compounds when the floor is renewed with incorrect material and moisture can arise to the structure capillary from the ground. Part 2 and part 3 of this research both have a lot of data from many moisture condition investigation reports, and previous examples are among the most typical causes for indoor air problems. Another study that is ongoing at TUT has found out that horizontal structures have more moisture damage than vertical structures (walls) (Annala et al. 2014). Damage that originates

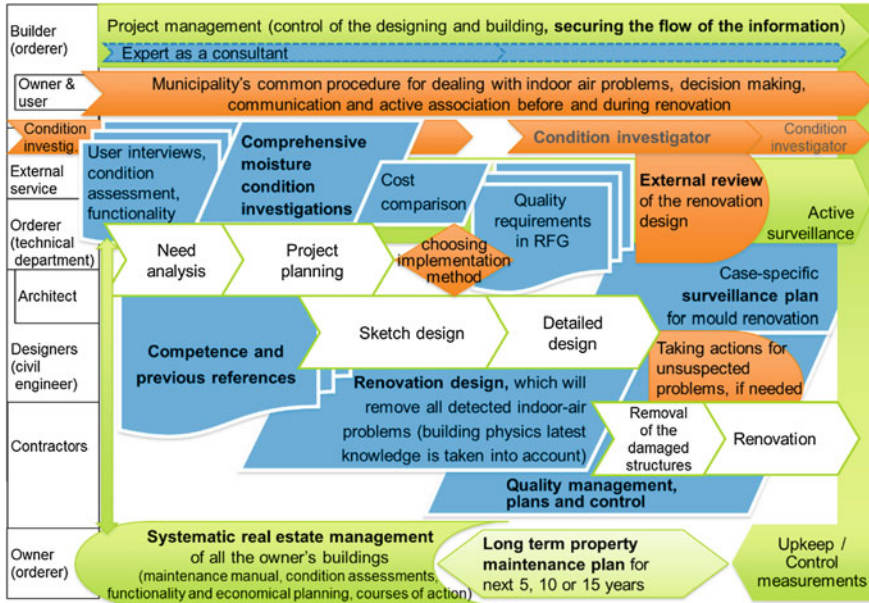


Fig. 3 Phases of the successful mould renovation

from, e.g., leaking roof, water pipe or insufficient waterproofing could have been avoided by regular maintenance.

Results and knowledge from condition investigations must be transferred to the designers, and they must take account of removing all of those and make sure that the new design will not allow the same or new faults to renew. Design defect is a very common cause for moisture damage, e.g. in the lower parts of the walls. Therefore, the designers must have the latest knowledge about all the possible indoor air pollutants, and they must know the physical behaviour of the moisture in the structures. In fact, everyone who takes part in the mould renovation projects must have competence and at least some basic knowledge about the moisture damage. These findings, quality of the design and competence of the parties stood up as second and third important findings after the importance of the condition investigations, when the results from interviews were summarized.

External inspection and review of the renovation design made a positive impact to some of the case projects and did help to avoid a faulty design, i.e. inspection caused redesigning in order to achieve moisture-technically better solution. External consultation is also useful for project management, if the municipality's own project manager does not have enough knowledge about the mould renovations, which is usually the case in many Finnish municipalities. Project manager also must have a wide understanding of the whole project. He must make sure that the



information flows from the very beginning of the project and from the previous repairs and investigations to the designing and implementation of the renovation. All the substantial information and systematic updates must be passed also to the users of the buildings.

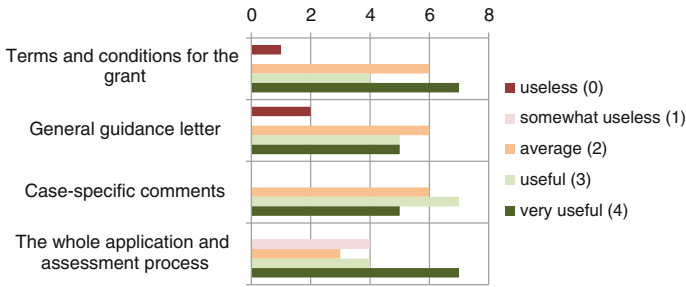
Process does not end when the renovation project is finished. Success of the project must be verified with the preplanned control measurements. Upkeep and property maintenance must be properly planned, controlled and verified. Municipalities should have a system and database for all their buildings. Knowledge about the technical condition of all the owner's real estates helps the prioritization of the projects. This research found out that the municipalities do not really use any tools or system for renovating their buildings in the certain order and with the certain method.

## ***4.2 Application Documents and Assessment Procedure***

Assessment procedures for allocating state grants have been laborious processes. All the experts in the external assessment group in 2012 were performing the assessments on top of their normal works. They pointed out that the document processing was difficult especially because of the variance in content and style of the appendixes of application documents. Officials of Regional State Administrative Agencies brought out the same difficulties with the process carried out on 2014 and 2015 (process of allocating the grants from supplementary allowance of 2013).

According to the interviews in part 2 of the research, the common understanding between the members of the assessment group and Regional State Administrative Agencies was that approximately half of the applications did not meet the minimum requirements for the state grant. In other words, half of the applicants did not necessarily have enough background data to succeed in the mould renovation project. Procedure of 2012 was new, it overlapped with summer vacations, and the applicants were not used to fulfil the applications with the asked appendixes. According to the interviews, municipalities did not have a clear understanding of the needed documents for the application. Same problems occurred in the latest state grant process that took place in 2014–2015. Almost half of the applications was rejected, though some of these applications had been chosen to pull out by the applicant them self. Procedure was again different from anything before, and the applicants were not familiar with it.

Municipalities do not have enough knowledge and competence to evaluate the quality and adequacy of the condition investigations. However, in both procedures, applicants were allowed to fulfil the applications according to the feedback from the assessment group and the Regional State Administrative Agency officials. Despite the feedback and answers about the content of documents, half of the applicants did not deliver all the missing documents before the deadline. That was partly because



**Fig. 4** Interviewees’ opinions about the different phases and the entirety of the application process. Scale is from 0 to 4, and 18 responses was collected. Length of the bar indicates the amount of opinions to the specific subject

it was not possible to meet all the requirements in such a short period of time, if the project was not already ongoing before the application. Allowance of 2013 was the last supplementary allowance of the year, and therefore, the application deadline was set in the end of January 2014, which made the total time for construction implementation even shorter, because the allowance had to be used by the end of 2015 (since the grants were allocated from three years transferable appropriation).

At research part 2, all the interviewees were asked to evaluate different phases of the application and assessment process with a scale from zero to four, where zero was described as “useless” and four as “very useful”. Overall opinion about the whole process was also asked with the same scale. Results are presented in Fig. 4, and those show that the process was mainly seen useful.

The questionnaires also collected positive feedback about the stricter state grant procedure and external assessments. Majority of the answers in questionnaire of 2012 concerned the projects where the preparations were started before the information of the additional state grant. Most respondents preferred higher amount of the grant, but the projects were started with the lower grant or without the grant too. According to interviews, some municipalities from the sample group of case projects were not sure, if the project would have started without the state grant.

Increased number of the subsidized projects shows that the impact of the state grant process was improved with the supplementary allowances. In 2012, only 8 projects got an allowance from the traditional state grant procedure. (In 2010, the amount of the subsidized projects was more or less the same) With the supplementary allowance, the total amount of subsidized projects in 2012 was raised to 54 projects. The amount of subsidized projects was more than doubled in the next process, when 131 projects got a state grant from the supplementary allowance of 2013.

This was a significant increase to the effectiveness of the state grant process, even though the percentual amount of the grant per project was cut down to less than half. Importance of the supplementary allowances was to help as many municipalities as possible. Unfortunately, no more allowance has been allocated

ever since, but the demand for the state aid still remains in most municipalities, because many public building owners are still struggling to repair their buildings.

### 4.3 Reasons for Application Rejecting

The decisions of Regional State Administrative Agencies were analysed in the research part 3. In these decisions, it has been pointed out why the application has not been corresponded to the regulation, where the terms and conditions for state grants were set. These shortcomings have been divided into five groups which were as follows:

- (1) All required documents have not been delivered, or they have been delivered late. Due to the shortcomings of documents, the technical condition or indoor air quality of the building remains unclear.
- (2) The schedule of the renovation project does not correspond to the regulation.
- (3) The renovation project has been cancelled by the municipality after the application has been delivered.
- (4) The total cost of the renovation project was under 300,000 €.
- (5) The application does not correspond to the regulation because of other reasons.

If there were several different shortcomings in the application, the application was classified into multiple groups according to the reasons. Figure 5 shows the reasons why the applications had been rejected. In 41 projects, the reason for rejection was the fact that the condition of the building did not become clear enough from the application.

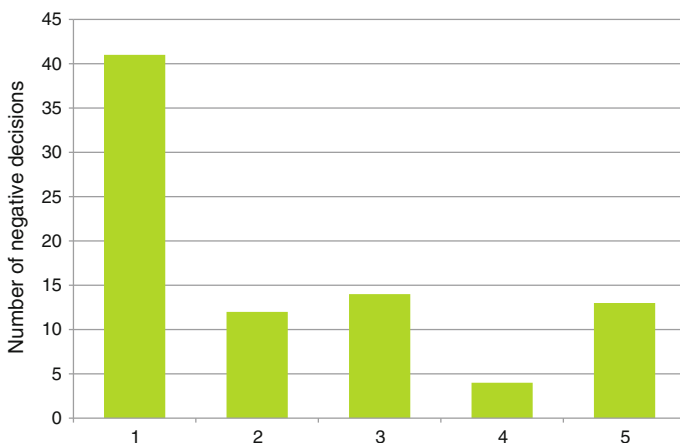


Fig. 5 Reasons for rejecting applications

## 5 Discussion

The aim of the Finnish supplementary state grants has been not only to initiate mould renovation projects, but also to help municipalities to success in their projects and also help Regional State Administrative Agencies in allocating the grants to the projects with immediate need and high probability of successful outcome. External review procedures were needed to achieve this goal. State grant procedures were quite different from each other, but the results were similar and show the need for development. This research at parts 2 and 3 not only studied these state grant and review procedures, but also pointed out the key factors for success in mould renovations in general. Three most important factors of success were identified as follows:

- (1) Proper condition investigations,
- (2) Every parties' competence, i.e. proficiency and professional knowledge about the mould renovations,
- (3) Check-ups about the
  - (a) condition investigation reports,
  - (b) renovation design,
  - (c) critical stages of operation during implementation,
  - (d) control measurements approx. year after renovation.

New guide about moisture condition investigations is going to be published by Finnish Ministry of Environment by the end of 2015. New guidebook should unify the format of the reports and methods of investigations. However, according to the findings of this research, an external inspection about the condition investigations is still recommended especially in state-supported renovation projects, at least for a transitional period until the quality of the investigations is proven to rise. Methods of inspection can vary from cross-check to the use of an external expert. These methods are described better in the subsection about future development, where a new form for the purpose of inspections is presented. Research team has outlined the form as a concrete result of the research.

Requirements for competence in moisture damage renovations have been made rather strict and exact in Finland during 2015. Developing the requirements took many years, and the major changes are now built into law. This is presumed to improve the quality of the projects. In other words, two out of three most important factors of success have been already improved after the last state grant procedure, which concerned the supplementary state budget of 2013.

However, in the end, it all comes down to the management and control of the general view and perhaps the most important factor of success is the correct attitude. Common attitude towards mutual goal is something that is not easy to achieve and cannot be regulated, because of the non-concrete nature of it, but that is something where the slow change should be driven. Fundamental idea with the review based and other ways strict terms and conditions in state grant procedures is to help municipalities to secure the success of their own projects with the cooperation of different parties and experts. Municipalities must understand that the

terms and conditions of application are not created for compulsory performance or something to be fulfilled with a minimum quality, but for something that drives towards mutual goal.

### ***5.1 Importance of State Grants and Factors of Success in Mould Renovations***

Application and external assessment procedure of 2012 got positive feedback from the municipalities in questionnaire and in the interviews that were carried out in the part 2 of the research. In case projects that were guided with stricter state grant procedure in 2012 and studied in part 2 of this research, the probability of success seemed better than in the case studies of the part 1, which studied the projects that were granted with allowance from state budget of 2010 and guided with traditional state grant procedure (Marttila 2014, Kero 2011). Case studies support the understanding that the development of state grant procedure has a positive impact to the success of mould renovations.

The external assessment group of experts not only helped the applicants to improve their projects, but also helped Regional State Administrative Agencies to allocate state grants for the projects with good chance of success. However, the process demanded a lot of work from the group of experts, and in the state grant procedure of 2013 (which was studied in the part 3 of this research), that load was shared to the experts' reports acquired by the applicants and delivered with the applications. Procedure of 2013 was still very laborious for Regional State Administrative Agencies, but this was because the terms and conditions of application were too open to interpretations and the municipalities were not familiar with the procedure, and therefore, regional administration officials had to request applicants to fulfil their applications.

Both supplementary state grant procedures pointed out that even lower size of the grant is effective to help municipalities to start their renovation projects, which is important in order to remove health risks in municipal buildings. State grant procedure not only gives funding to start the projects, but also helps municipalities to achieve a successful result by choosing correct renovation method and paying attention to the quality of the implementation.

However, terms and conditions for the state grant procedure must be understandable clearly, and those must have a concrete positive impact for the renovation projects. State grant procedure must be systematic in order to make a long-term impact for improving IAQ and lowering the health risks in public buildings. For the same reason, there should be a constant annual allowance for mould renovation projects in the state budget. Applicants must have enough time to prepare the projects properly, e.g. to conduct or acquire all the necessary condition investigations. Assessment procedures have increased the knowledge about mould

renovations in municipalities. In this research, the following factors were recognized as paramount importance for a successful mould renovation project:

- Comprehensive moisture condition investigations;
- Competence of all the people who take part in the project (and previous references);
- Proper renovation design and right solutions for removing all indoor air problems in the building;
- Case-specific plans for quality assurance;
- External inspection for renovation design;
- Instructions for surveillance of the project;
- Systematic building management and property maintenance and timely repairs;
- Secured flow of information from the very beginning of the project to the implementation and to the users of the building.

Important step in the initial phase of the building project is cost analysis between renovation and new building, unless the building cannot be or must be demolished. Along with the economical retrospect, knowing the condition of the building always plays a huge role in the decision between repairing and demolishing. Third main reason is the future use of the building. Need for space is changing along the use; e.g., educational methods are changing and the former space arrangement in school cannot always be turned into effective modern use.

In fact, most important phase of the project is the very beginning of the project. Decisions made in the beginning have the biggest influence to the costs of the project, but the initial phase itself does not cost much, so this phase should be carried out thoroughly and with care. Unfortunately, it is often rushed through, and irregular state grant procedures with too tight schedule do not support the proper actions.

In other words, condition investigations are inexpensive and they form the beginning source of information. Knowing the condition of every part of the building from structures to HVAC systems is extremely important when renovating an old building that is suffering from moisture, mould or other indoor air pollutants.

## ***5.2 Further Development***

State grant procedures in Finland still need to be developed. Main problems have been too laborious and unequal handling processes and differences in interpretation of the terms and conditions of application. Therefore, a specific form has been established as a result of part 3 of the research. Building projects are very different from each other especially when renovating and that is why the form is not made too strict, but it is unambiguous enough to compare different projects and to evaluate the probability of success in removing the IAQ problems of the building.

Basic idea of the form is to secure a flow of information from each phase to another and also find the possible blank spots or even defects in the condition

investigations, in project plans or in renovation design. This is achieved by second person's opinion, i.e. by inspecting the documents. The form offers two ways for task, which are as follows:

- (1) Cross-check;
- (2) External review by expert.

Cross-check means that the structural designer goes through the condition investigation reports and makes sure that he has all the needed information for designing the renovation. Perhaps even more important is that the condition investigator checks that the renovation design is taking into account all the findings that he has made in the investigations. This was the idea with the expert's opinion procedure that was required by the regulation and used for the additional state grant procedure of 2014–2015. However, inaccurate terms and conditions made it possible for condition investigator to evaluate his own findings and write a short open format report about those. Some of the structures could have been left without investigation, and by the regulation, the renovation design was only requested to remove the problems that were found in the condition investigations.

Therefore, the new form would request a short, but separate analysis about the each and every building element. In the form, the idea of the cross-check is that the investigator fills in the findings from condition investigations and the designer or an external expert checks that the investigations have been comprehensive enough. Same way the investigator checks the performance and quality of the new structures by going over the short descriptions, which the designer has filled in the form. Benefits of the process are that it involves different parties to open discussion, and no external expert is necessarily needed.

On the other hand, second way to use the form would be that an external expert evaluates both, condition investigations and renovation design. Expert would have a fresh view to the problems of the building and better possibility to see the overall picture.

## 6 Conclusions

Renovations related to moisture and mould damage or to other indoor air quality problems in Finnish municipal buildings have often failed to remove all the indoor air pollutants. Quality of the preparations and implementation has not been sufficient, which have led to unsuccessful outcome of the project. Some of the unsuccessful renovations have been supported financially by the state, which cannot be accepted in the future any more. All the failing renovations cause a lot of unnecessary costs, but the greatest expense is the health of the employee and students.

Successful renovations can be carried out, but the challenge is not easy, e.g., because the demand for energy saving changes the structures and the moisture behaviour of those. Building physics are, however, a simpler issue than estimating someone's personal limit for exposure to different indoor air pollutants. At this

complicated field of expertise and in the need for multi-professional knowledge, at least the simple mistakes like the lack of property maintenance and inadequate condition investigations should be remedied immediately. Condition investigations and other good preparations are very cheap compared to the building costs, and those can save the project from defective method of implementation.

Among the importance of the condition investigations, quality of the design and implementation was pointed out as a key factor for successful mould renovation projects in this research. Good quality can be achieved by review procedures and by the competence and right attitude of all the people who take part in the project. State grants must be allocated to the projects with good chance of success. The application and allocation procedure has been beneficially developed in the direction to help that goal and to increase municipalities' know-how for preparing a project with successful outcome and improving the indoor air quality of the public buildings. However, the process still needs more development and research. The current data should be extended with the results from monitoring measurements of the same projects and then analysed in order to compare the real outcomes and efficiency of different renovation methods.

## References

- Annala PJ, Suonketo J, Pentti M (2014) 'Kosteus- ja mikrobivauriot koulurakennuksissa TTY:n suorittamien kosteusteknisten kuntotutkimusten perusteella'. Sisäilmastoseminaari 13.3.2014 Helsinki. Suomi SIY Raportti 32:301–306 (in Finnish)
- Haverinen-Shaughnessy U, Hyvärinen A, Putus T, Nevalainen A (2008) Monitoring success of remediation: seven case studies of moisture and mold damaged buildings. *Sci Total Environ* 399(2008):19–27
- Kero P (2011) Kosteus- ja homevauriokorjausprosessin arviointi kuntien kiinteistöissä. Tampereen teknillinen yliopisto 2011. Master's thesis. 62 pages (in Finnish)
- Marttila T (2014) Valtion tukemien homekorjaushankkeiden arviointi. Tampere University of Technology. Master's thesis. 50 pages (in Finnish)



# Recovery and Enhancement of Modern Architectures: The Case of Cinema Ariston in Potenza (Italy)

Antonella Guida, Ippolita Mecca and Silvia Michela Scavone

**Abstract** The architectural heritage of the modern is in addition with the historical and cultural heritage that are the “beauty” of Italy. The starting point of this research is to reuse an area of the historic city centre of Potenza and to recover an historical architecture abandoned: the Cinema Ariston. It is built in the 50s of 900s, and it is a significant example of modern concrete architecture in the town. The original function of cinema includes it in those buildings that have marked the history of the town and today cannot be deleted from the memories of all citizens and it should be enhanced as a central element for the renovation. An accurate metric and metric survey and a diagnostic investigation (including pachometer, sonic and ultrasonic tests) have been carried out to define the project. The results obtained were used to implement an analytical model for the study of the seismic vulnerability and to define the conservation interventions and structural rehabilitation. The recovery project includes also a new construction and proposes the recompletion of the existing, partially demolished, through new elements and modern materials. The policy adopted for conservation and the new intended use ensure a future for the Cinema Ariston and the urban space connected to it; the aim was to perpetuate social and historical memories of buildings that have no particular values for the preservation, but retain other important values to be transmit.

**Keywords** Diagnostic · Vulnerability · Recovery · Enhancement · Integration

---

A. Guida (✉) · I. Mecca · S.M. Scavone  
Department of European and the Mediterranean Cultures, University of Basilicata,  
Via dell’Ateneo Lucano 10, 85100 Potenza, Italy  
e-mail: antonella.guida@unibas.it

I. Mecca  
e-mail: imstudio@live.com

S.M. Scavone  
e-mail: silvia.scavone@hotmail.it

## 1 Introduction

In recent years, the need to protect land and to redevelop existing buildings has highlighted the fact that the only way to respond to the variety and the specific characteristics of a large number of complex situations is to work to save the architectural heritage. The restoration project begins with conservation, by means of maintenance and preservation, and with improving the energy performance, the structural performance and the level of indoor comfort of the existing buildings.

The restoration project aims to understand and make a synopsis of interpretations of history. It allows us to reinvent a particular part of the building in relation to what it was before, but without erasing its original entirety and always ensuring that any future work is of a high architectural standard. It is therefore fundamental to have a knowledge of the building at the centre of the project, by using an interdisciplinary approach. This approach requires gaining knowledge of the dimensions, materials and construction of the building, and uses a method that aims to enable us to understand the locations and spaces of the remains that we want to salvage. The flexible design of the project guarantees continuity with architectural works of the past, and through a knowledge of the different historical layers of the building, the design can allow solutions to be found on the basis of the relationship between analysis and project and between project and construction. This is the fundamental objective of the project to save the Cinema Ariston of Potenza, which is possible by means of an intense process of research, analysis and planning.

## 2 Urban Background and Historical Context

Before a good restoration project is carried out, there needs to be a careful study of the architectural remains. This study should be conducted from various points of view and should take into account the building's position in the local context and in the urban fabric, as well as other typological, structural and constructive aspects. The study must follow a precise methodological framework that will start with a historical analysis and a survey and then move onto diagnostics, thus making it possible to conceive a project that is tailored to the real needs of the building.

### 2.1 *Urban Context*

The building in question is located in the heart of the old part of the city centre of Potenza, the regional capital of Basilicata, in southern Italy. Given this particular location, an analysis of the area is of vital importance regarding first of all an understanding of the building, and secondly the planning. By examining the urban network and its origins, we can see that the Cinema Ariston is located near the

pre-existing route,<sup>1</sup> which can be followed in via Pretoria,<sup>2</sup> the main backbone of the old part of the city that extends from Portasalza<sup>3</sup> to Torre Guevara.<sup>4</sup> Over the centuries, new urban areas have been added to the initial central part, which was built directly next to the pre-existing route. The new urban areas are comprised of roads connecting the buildings, and other roads, which are at a right angle.<sup>5</sup> The Cinema Ariston is situated between two routes, which connect the perpendicular roads. In fact, the main entrance is on Via IV Novembre (a road that connects the perpendicular-side roads) and Via Mazzini, both of which run parallel to the main road, Via Pretoria (Fig. 1).

The area being studied is characterized by an urban network consisting of compact buildings that almost recreate a continuous line of buildings, which is a characteristic of all the neighbourhoods built in Potenza in medieval times, even though the urban area in question dates back to the 1950s and 1960s. From an architectural point of view, the Cinema Ariston was built in 1955, a time of immense creative activity. The building is in keeping with the highest level of research on the use of reinforced concrete and the cinema belongs to the modern architectural style that was typical in Potenza during the advent of Fascism.

## 2.2 *Historical Events*

The Cinema Ariston dates back to performance venues founded in the city between the twentieth and the twenty-first centuries, with the project created by the engineer Augusto Mango. The cinema was built near the compact row of houses in the centre of Potenza, near the Prefect's Palace and near the former home of an aristocratic family, when the earlier town centre was the subject of expansion. The contrast

---

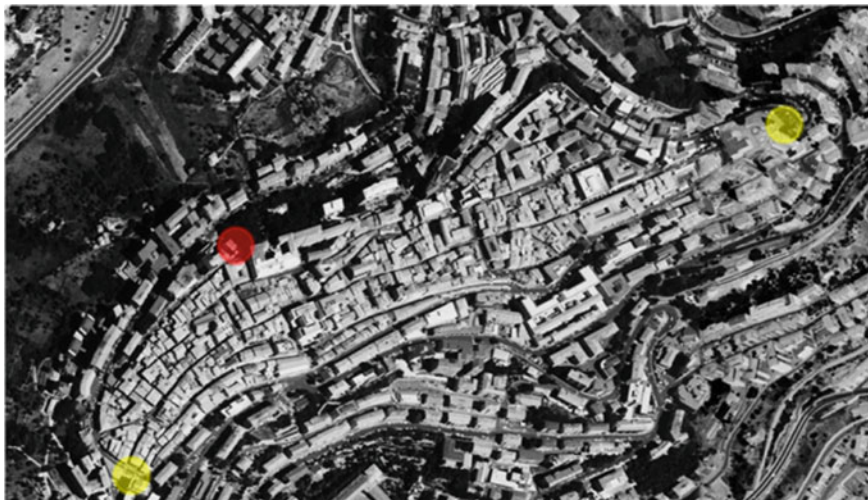
<sup>1</sup>A pre-existing road is generally a route that connects two points at which buildings have been erected, because of the proximity of the two points. It is, therefore, a factor, which causes buildings to be created (Caniggia and Maffei 1979).

<sup>2</sup>The city of Potenza was a Roman military colony where Silla founded the Praetorium (Command of the Romans) and the camp of the Praetorians. The road link between the military camp and their command centre was called Via Pretoria. Over the years, this route has never changed its name and still covers all of the old part of the city.

<sup>3</sup>The old farmhouse of Portasalza, located outside the city walls, gave the name to the door until it was demolished in 1816 and was the only entrance route to the city that was controlled. It was called the city gate and was located at the beginning of Via Pretoria, at what is now the crossroads formed by the two-side streets where the little hill of Portasalza ends.

<sup>4</sup>Torre Guevara was built in the ninth century, at the same time as the city walls were rebuilt. Later, a fortified structure was built around it that was to transform the castle of the Counts of Potenza. This castle has undergone many changes over the centuries, as a result of its many different uses, until its demolition in the 1960s. Today, after the demolition of the castle, Torre Guevara went back to being an isolated structure at the end of Via Pretoria.

<sup>5</sup>The road that connects the perpendicular-side streets was created after the area was built on various routes within the building scheme and was created in anticipation of the buildings, which were to be put up on the outer edges (Caniggia and Maffei 1979).



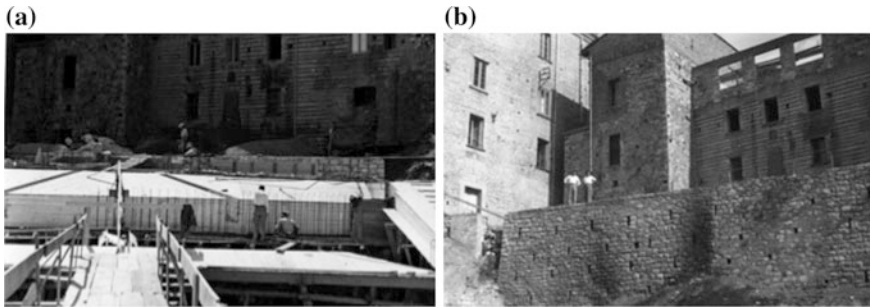
**Fig. 1** Site plan

between the new building, made of reinforced concrete and the types of buildings next to it, which date back to the eighteenth and nineteenth centuries, highlights the historical transition from traditional building techniques to innovative ones, which then went on to modify the urban structure and architecture of the city.

Building of the cinema was started in 1954, the year in which the executive plans were drawn up and the building work lasted until 1955. The building work was done quickly, despite the difficult hilly conditions of the site. In the early years, a huge variety of films were shown. After the earthquake of 1980, the building was closed for a few months, to allow for checks on the building, which, however, did not suffer any particular damage, compared to the rest of the housing that was seriously affected by the catastrophic event.

There were phases of closure alternated with periods of normal functioning, despite the extensive competition in the city with six other places used for film showings. The presence of other screens did not, however, hinder the Cinema Ariston, which was the only building constructed solely for this purpose, and which therefore offered good quality. The period of decline began in 1993, when the cinema suffered the sad fate, still noticeable today, of being closed for long and complex work to be carried out. The work involved the construction of a stage, which was needed in order to combine activities of film, theatre and music, in an effort to ensure that the cinema offered better quality and a more varied supply of activities. The work was expected to last two years, but this time limit was never respected, and since then, bureaucracy has been interspersed with administrative problems, which have prevented the many projects, drawn up over the years, from being carried out.

In 1995, the cinema was closed permanently, according to the wish of the supervisory committee, which highlighted the shortcomings of the property,



**Fig. 2** Historical pictures. **a** Historical picture of construction site 1; **b** Historical picture of construction site 2

especially in terms of safety. Meanwhile, the Ariston became the subject of several projects, which aimed to change the layout of the building, to enable it to adapt to demands, to regulatory requirements, and to the needs of the community (Fig. 2).

Now, twenty years on from the closure of the Ariston, the cinema is still very much alive in the memories of most of the city's population, but what remains of the cinema today is bleak, abandoned and represents a picture of the collapse of an "architectural ruin" that "expresses" its disapproval to a widespread lack of interest.

### 3 The Level of Preservation

In order to tackle a restoration project, it is necessary to have precise knowledge of the physical state of the building. The survey was very broad and included tests and trials to establish what the materials, the construction techniques and the degree of degradation of the building were. The more accurately and objectively an early analysis is carried out of the state of preservation of the building, the more exact the plans will thus be (Figs. 3 and 4).

#### 3.1 *Architectural and Structural Features*

The Cinema Ariston is an important example of modern architecture, and its historical and architectural importance is due to its position within the well-established urban fabric, a fabric, which is the result of the systematic evolution of human settlements. Moreover, the cinema's architecture places it amongst the buildings of the mid-twentieth century that can still today be the focus of a process of preservation, understanding and transformation. Such a process is typical of the very theory of how to save the architecture of the recent past, architecture, which can be particularly difficult to save.



Fig. 3 The south-west facade



Fig. 4 The north-west facade

The first aspect, which should draw our attention, is the cinema's location, which has meant that the building is fully enclosed, with two of the four sides "hidden". To the west, one side of the cinema is completely attached to a block of flats, while to the east the other side of the cinema is attached to the boundary wall of the Prefect's mansion.

The mansion represents an important historical part of the nineteenth-century urban fabric, built on terraces connected by walkways and staircases with balustrades, dense and lush vegetation and trees that are centuries old. Moreover, since the surrounding buildings are much taller than the cinema building, the cinema is totally obscured within the urban environment. In order to describe the architectural configuration of the building, we must describe both the floor plan and the non-linear elevation at the same time, both of which are conditioned by the morphology and orography of the site.

The Cinema Ariston therefore lies crosswise on a natural slope that has been fully incorporated into the adjacent buildings. In terms of the floor plan, the building follows the lie of the plot of land, which is narrow, elongated and rectangular, and within this space there are several irregularly shaped areas. The main façade, in the upper part of Via IV Novembre, has large areas of glass, which have been bricked up and obscured over the years, alternated with continuous sections of plastered wall, which are partly coated with ceramic material. What stands out most of all on the façade is the yellow sign, which indicates the original main entrance. The sides of the building are made entirely from masonry veneer walls, and here, there is no room for windows, but only doors, which can be used as emergency exits. If we examine the north-west side, on Via Mazzini, the cinema currently looks gutted, due to the demolition and weakness of the vertical elements such as doors, windows and walls, and thus, we are able to observe what remains of the spaces and of the internal divisions of the structure. One element that characterizes the exterior of the building is the unusual roof, which is divided into three different parts. The first level covers a part of the building, which juts out, in the shape of a parallelepiped (Figs. 5 and 6).



**Fig. 5** The stall area view



**Fig. 6** The circle area view

The second level has a curved vaulted ceiling, which is lower than the first level, and finally, there is a third level, which is also lower and curved in shape. Looking at the floor plan, we do not perceive a sense of the structural complexity of the building, because the intended use of the space as a cinema necessarily requires large regular-shaped areas, which indeed characterize the cinema, which is rectangular whereas the side rooms are irregular in shape, having been created on and moulded directly onto the sloping ground.

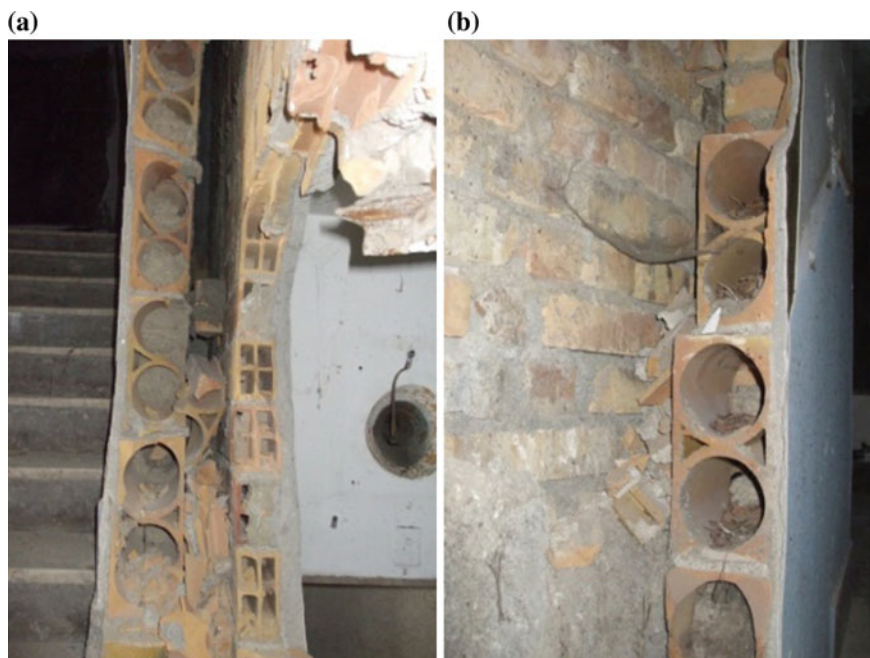
The clear and simple functional organization allows us to identify the spaces necessary for the showing of films, such as the foyer, the film theatre, the projection room and the area in which to place the screen, which is now no longer visible because it has been demolished. If we examine the height of the building, we can clearly see the complexity of the structure, which follows the morphology of the land and adapts to it without changing it, while, at the same time, seeking the right static and dynamic balance. Moreover, we can see three different levels, which are firstly the stalls, “suspended” at an intermediate height between Via IV Novembre and Via Mazzini, secondly the foyer and the circle, and thirdly an upper floor, with direct independent access from Via IV Novembre, where various activities were carried out, but which is now completely separate from the cinema. There are four toilet-facility areas: two opposite each other in the circle area, another at the landing of the staircase, from the stalls to the foyer, and the fourth on the same level as the stalls. The stalls can be reached from the foyer by going up two flights of stairs, which are positioned symmetrically, and which serve ideally as a link between the two parts of the building, which seem to be independent. The circle has terraced steps, which are divided into two separate areas by a central aisle. The stalls consist of a single large space that is not divided in any way. The stalls have been completely changed by human activity,



and here, there is little evidence of the stalls' original architectural appearance. It is difficult to understand the structure of the building perfectly and completely, because it was impossible to find the entire structural plan. However, some partial, incomplete documentation was found in the archives, which, combined with site visits, has enabled us to create a complete picture of the architectural structure. To provide a thorough analysis of the existing building, it is crucial to emphasize that unlike what you would find if you examined the size and volume of the building in plans and elevations, the building has a single load-bearing frame that provides direct connections between the two parts, which would ideally be separate, namely the foyer, on the one hand and the circle and stalls on the other. The structure of the frame of the foyer has beams and pillars in a regular layout, and hollow-core concrete floors. Its structure is different from that of the stalls, where there is a series of portals in longitudinal, transverse and diagonal directions, corresponding to a regular network of pillars, of different shapes, and a row of numerous intersecting beams positioned close together, where the circle is located. From the regular network of pillars, both at the level of the stalls and at the level of the circle, you can see numerous ledges made of reinforced concrete, projecting outwards, where there are hollow-core concrete floors, both above and below, in such a way as to create the steps of the circle, and the staggered levels for the roof of the circle, which consists of two vaulted ceilings made out of reinforced concrete. As regards preservation, even though the building has been greatly affected by human activity, the original structure of the building is still intact, which allows us to discern and identify its distinguishing architectural features. The north-west part of the building and the floor of the stalls have been partly demolished, and cladding and finishing materials have been removed. These procedures have been carried out over the years and now make it possible to observe the "skeleton" of the building, and thus, it is only by using our intuition and perception that we can imagine what the complete building was originally like. In addition, environmental factors, exacerbated by the fact that the building has been totally abandoned, have triggered a series of degradation processes, which have altered the appearance and features of the building.

The main causes of the degradation of the building have been identified and a precise picture has been made. The causes can be eliminated in the planning stage, in an attempt to recreate the best conditions for the preservation and protection of the building. The important nature of the building has provided vital information on the period of its construction, on the construction techniques used, on the methods used and the design concept, thus permitting a critical interpretation of the building, and the subsequent drafting of a proper plan for its preservation and restoration.

A material survey was conducted by combining the information available with a direct analysis of the remains of the building and then making comparisons with other buildings, which are similar in terms of the building's function and the buildings' history and construction. This analysis was carried out on the exterior of the building, as well as on the interior, which has been subject to more changes over the years. It was noted that items of historical and artistic value had been removed during previous work, and demolitions had also taken place, which had erased some historical evidence.



**Fig. 7** Walls with “goggles”. **a** Wall with “goggles” type 1; **b** Wall with “goggles” type 2

The construction materials used include reinforced concrete, concrete and bricks; in particular, the vertical and horizontal skeleton of the frame is made of reinforced concrete, while the vertical elements, such as doors, windows and walls consist of different types of brick: solid brick, hollow brick with three and four holes and perforated bricks, commonly called “goggles” because of their circular holes. It is interesting to note that the structural elements, the pillars and the foyer, were of particular decorative and architectural significance, with a finish that was typical of the time, which can be found in an equally important piece of architecture in Matera, namely the Duni Theatre. In fact, the finish of the pillars is made of a special type of stucco called “fired stucco”. The “fired stucco” technique involves spreading several thin layers of plaster in order to make any rough surfaces smooth; subsequently, layers of coloured stucco are added, hot irons are used on the stucco layers, and finally, the stucco is polished (Figs. 7 and 8).<sup>6</sup>

<sup>6</sup>This technique involves a series of different phases of work, which are a first layer of substrate made of mortar with sand and concrete, levelled with a mortar of lime, white cement, hydrated lime and fragmented limestone, followed by three thin layers of plaster consisting of white cement, lime and fragmented limestone and finally three layers of stucco made of white cement, lime and marble dust. The next stage of polishing, with a brush, is done using a solution of slaked lime, soap flakes, colophony, egg yolk and warm earthy colours, after which hot irons are used, the stucco is

**Fig. 8** Acoustic perforated panels in pink plaster



The horizontal elements, such as roofs and floors are made partly of hollow-core concrete and partly of reinforced concrete slabs, which were found in the steps of the circle and in the vaulted ceilings. The material survey made it possible to identify the different types of brick used, the various types of masonry adopted and the thickness of some walls that could not be measured easily. As for the cladding and finishing materials, it is important to note the acoustic panels, which can be divided into grooved, perforated panels in pink plaster, used for cladding the walls inside the theatre, and other grooved panels in blue plaster, in the foyer that were fixed onto a wooden framework (Fig. 9).

### **3.2 *Decay and Decline***

Once we had become familiar with the building, after analysing its history and taking the measurements and performing structural and material surveys, we were then able to perform the diagnostic tests, firstly by carrying out an analysis of the level of decay of the building and secondly by non-destructive testing (NDT) of the structural elements. The widespread degradation and cracks detected have been

---

(Footnote 6 continued)

dried and finally brushed with pure alcohol and given a final polishing with woollen cloth to ensure a smooth and bright surface (Acito 1999).



**Fig. 9** Acoustic grooved panels in blue plaster

caused mainly by inappropriate human intervention, a complete lack of maintenance and total abandonment, which has exposed the building to wear and tear from external factors for such a long time. A careful survey of the type and entity of the degradation of the building has allowed us to identify crumbling and missing walls, the presence of debris, various materials, surface discoloration, extensive vegetation and humidity in the areas most exposed to the elements, as well as the presence of veneer, efflorescence and detachment, and degradation of the top layers of the



**Fig. 10** Degradation of the foyer



**Fig. 11** Degradation of walls in the circle area

materials, and finally various damage related to man's direct intervention, such as gaps in the floors and the absence of substantial parts of the building due to the demolition work carried out (Figs. 10 and 11).

From a structural point of view, only one crack has been found, at the intrados of the circle. The crack's outward appearance shows discontinuity in the substance, which may therefore mean that the two parts have moved (Fig. 12).



**Fig. 12** Degradation of the stall area

## 4 Diagnostic Survey

The diagnostic survey was aimed at assessing and defining what a sufficient level of knowledge about the building would be and was conducted by means of planning a detailed and complex survey project. For financial reasons, non-destructive type tests (NDT) (Masi 2005) only were carried out. These tests served to work out the position of the reinforcing bars inside the parts of concrete, by means of pacometer tests, and these served to ascertain the homogeneity of the concrete, with sonic and ultrasonic tests. The results of sonic and ultrasonic tests were used together to estimate the strength of the concrete using the SONREB method.

Once the tests had been performed, the experimental results obtained were then interpreted and used in the VC (vulnerability of reinforced concrete) (Dolce and Moroni 2005) analytical model, which enabled us to identify the structural behaviour of the building and its resistance.

### 4.1 Non-destructive Diagnostic Tests

Non-destructive methods of testing are less invasive because they do not involve taking part of the material away, but they provide important information on the characteristics of the substance being investigated and, therefore, they represent a valuable tool for an overall understanding of the building that is being studied. When NDT was carried out, the areas and the test surfaces were prepared and selected by referring to the specific UNI [the Italian national technical standards authority] standards. In fact, the surfaces tested, which must be free of defects that may affect the result, as well as of dust and impurities, were treated to eliminate any possible plaster and mortar residues.

Six points that needed to be investigated were identified, in relation to the layout, the size and the accessibility of the building. Three of these points concerned the top floor (the foyer and the circle) and three the lower level (the stalls) (Fig. 13).

Pacometer scans were carried out, which allowed the available information to be verified, concerning the position and the amount of reinforcement present in the pillars, information which was deduced from the original features of the building. Ten measurements were taken of the rebound value (rebound hammer test) of each pillar, on each accessible side, and each pillar was identified with a code. These measurements, in addition to the average values, are shown in Table 1.

The results obtained show that the rebound index of the first material investigated (Pa\_1) and of the second (Pg\_2) are significantly different from the value obtained from the average of the rebound indices of the six tests carried out.

In the case of the first part analysed, the results are affected on the one hand by the fact that the piece is of a different geometrical shape, with a round cross section, whereas the other parts are rectangular, and on the other hand by the fact that it is made of a different type of material; in fact, the outer layer of the pillar is of fired



**Fig. 13** Non-destructive tests

**Table 1** Rebound hammer tests' values of pillars

Code	Dimensions (cm)	Rebound hammer tests										Average value	Ir
		Rebound values											
Pa_1	d: 30 ÷ 90	36	32	32	35	36	34	32	37	32	38	34.4	34.8
		38	37	36	32	37	38	32	34	32	35	35.1	
Pg_2	45 × 50	45	50	53	56	52	46	48	50	50	45	49.5	49.5
Pp_3	40 × 50	38	36	38	42	46	40	40	44	36	44	40.4	40.4
Pg_4	50 ÷ 80 × 70 ÷ 140	38	38	42	40	39	40	42	39	38	40	39.6	39.4
		40	38	42	45	38	38	39	38	38	36	39.2	
Pp_5	40 × 65	38	40	38	42	39	40	40	42	38	38	39.5	40.8
		42	42	42	45	44	45	44	38	38	40	42.0	
Pp_6	70 × 25	38	33	38	37	35	39	37	34	36	35	36.3	36.3

stucco which, although the layer of stucco has been removed, has a consistency and characteristics that are different from those of the cement plaster used on the other pillars (Table 2).

Ultrasonic tests were conducted on each pillar, and the values of the average wave propagation speed within the pillar were calculated. These values are obtained from the average of the different propagation velocities, which are obtained, in turn, from the different measurements taken of the transparency, semi-transparency and of the surface, both in a horizontal and in a vertical direction. The following table shows the values of the average velocities obtained for each pillar.

Comparing these results with the established research results of the sector, in most cases the concrete in question is in bad condition, since the average speed is less than 3000 m/s (Pa\_1, Pp\_3, Pg\_5), a value, which is indicated, in established

**Table 2** Sonic tests' values of pillars

Code	Dimensions (cm)	Average velocities (m/s)
Pa_1	d: 30 ÷ 90	2190
Pg_2	45 × 50	3382
Pp_3	40 × 50	2984
Pg_4	50 ÷ 80 × 70 ÷ 140	3505
Pp_5	40 × 65	2290
Pp_6	70 × 25	3367

practice as the minimum acceptable threshold (Masi 2005; UNI EN 12504-4 2005). The results obtained from each single measurement were then analysed to calculate the average velocity of propagation for each element investigated, and these averages were then combined with the rebound indices in order to assess the resistance of the concrete using the SONREB method. The name of the SONREB method derives from SONic REBound (ultrasonic and rebound hammer), is a NDT method for assessing the strength of concrete in existing structures and permits the researcher to offset some of the mistakes, which might be made using the two types of test individually. It is a method that is quick to implement, because the test techniques are straightforward and non-invasive. It is not suitable for concrete with surface layers that are in particularly bad condition, or on parts of concrete where there is a high concentration of reinforcement or on parts in which the concrete has obvious defects.

The SONREB method (Bocca and Cianfrone 1983; Gasparik 1992; RILEM NDT 1993; Di Leo and Pascale 1994; Del Monte et al. 2004; Masi 2005; Giacchetti et al. 2005) involves an assessment of the local values of ultrasonic velocity  $V$  and of the rebound index  $S$  to be calculated, from which it is possible to ascertain the value for the strength of the concrete  $R_c$  from the expression:

$$R_c = a V b S c$$

where  $a$ ,  $b$  and  $c$  depend on the methods used for conducting the experiment. Established research provides us with several expressions, depending on the research conducted by different authors.

In the case in question, there is no data concerning the extraction of core samples and therefore there is no data from destructive tests. Consequently, in order to be able to rely on the results of the estimate of the strength of the concrete, the data provided by NDT (i.e. the rebound index and average ultrasonic velocity) was inserted into the expressions in the established research on the subject, using the coefficients proposed by different authors (Table 3).

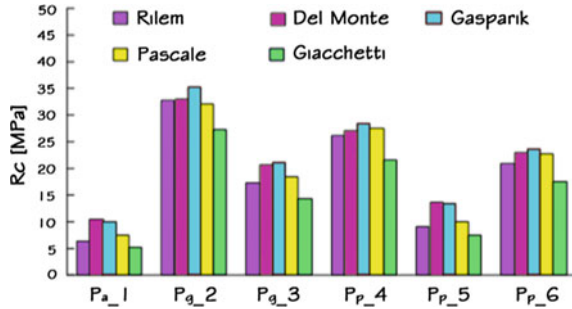
The results of these calculations show how the different expressions used for the different parts of concrete analysed, give relatively comparable results. However, it is clear that we cannot describe the concrete as homogenous, because in the first and fifth point under investigation, the results of the strength of the concrete are lower than those of the other points, while the second point of investigation has higher values. These differences depend, of course, on the results of the non-destructive



**Table 3** RC equations by different authors

Author	Equation
RILEM (1993) NDT 4	$Rc1 = 9.27 \cdot 10^{-11} \cdot V2.6 \cdot S1.4$
Gasparik (1992)	$Rc2 = 8.06 \cdot 10^{-8} \cdot V1.85 \cdot S1.246$
Di Leo and Pascale (1994)	$Rc3 = 1.20 \cdot 10^{-9} \cdot V2.446 \cdot S1.058$
Del Monte (2004)	$Rc4 = 4.4 \cdot 10^{-7} \cdot V1.127 \cdot S1.69$
Giacchetti	$Rc5 = 7.685 \cdot 10^{-11} \cdot V1.40 \cdot S2.60$

**Fig. 14** Graphic of resistance of the concrete by the SONREB method



**Table 4** Resistance values of the concrete by the SONREB method

Code	Ir	Vm	Rc (MPa)				
			RILEM	Gasparik	Pascale	DelMonte	Giacchetti
Pa_1	34.8	2190	6.45	10.14	7.58	10.60	5.35
Pg_2	49.5	3382	37.76	35.21	31.94	32.92	27.19
Pp_3	40.4	2948	17.24	21.20	18.41	20.76	14.31
Pg_4	39.4	3505	26.11	28.31	27.38	27.04	21.68
Pp_5	40.8	2290	9.05	13.43	10.01	13.68	7.51
Pp_6	36.3	3367	20.97	23.76	22.76	23.04	17.41

tests. The minimum, average and maximum cylindrical resistance values of the concrete are important for subsequent analyses and to assess the seismic vulnerability of the building. Therefore, it was decided to identify a minimum, average and maximum value of the resistance of the concrete, to be used in the analysis model of vulnerability and seismic risk, by parametric testing (Fig. 14) (Table 4).

## 4.2 An Assessment of Vulnerability and Seismic Risk

An assessment of the vulnerability and seismic risk of the cinema was carried out using the VC procedure (Vulnerability of Reinforced Concrete, engineer and lecturer Mauro Dolce and engineer Claudio Moroni).

A structural outline of the building was created, to allow us to switch from analysing a building with an irregular and complex shape, to analysing a simplified shape instead. The part of the building that was analysed, namely the stalls and the circle, had a regular, symmetrical shape and this is, at the same time, the part with the most structural problems.

Once the physical, geometrical and mechanical characteristics of the building are known, the structural model is able to identify collapse mechanisms of the floor, indicating whether the problem is caused by shearing and/or bending of the individual pillars, in relation to two levels of damage: the serviceability limit state (SLS) of functionality and the ultimate limit state (ULS) of collapse.

The simulation model was developed using parametric testing, considering the important parameters that influence the characteristics and the behaviour of the structure. These are the cylindrical resistance of the concrete, the average yield strength of the steel, the weight of the floor, the type of ground and the presence or absence of infill walls. Different values were used for these parameters, and when the values are combined, they offer 30 different possible types of calculation and, therefore, 30 different safety assessment values. The results obtained from this analysis have indicated the collapse caused by bending of the pillars and have provided the values of peak ground acceleration (PGA).

The seismic action was evaluated in relation to the different limit states that were being considered and in relation to the parameters of seismic hazard of the site being studied (Fig. 15).



Fig. 15 Parameters of seismic hazard of the Cinema Ariston

**Table 5** Risk indicators—  
ULS of collapse

$\alpha_u$				
	Pt dir. X	Pt dir. Y	P1 dir. X	P1 dir. Y
Minimum	0.65	0.36	0.35	0.33
Average	0.74	0.40	0.40	0.58

**Table 6** Risk indicators—  
ULS of life safety

$\alpha_{l1}$				
	Pt dir. X	Pt dir. Y	P1 dir. X	P1 dir. Y
Minimum	0.90	0.50	0.48	0.45
Average	1.02	0.55	0.55	0.80

**Table 7** Risk indicators—  
SLS

$\alpha_e$				
	Pt dir. X	Pt dir. Y	P1 dir. X	P1 dir. Y
Minimum	0.90	0.50	0.48	0.45
Average	1.02	0.55	0.55	0.80

The nominal life expectancy of buildings used as public places for entertainment for large numbers of people is set at  $V_n \geq 100$  years and the use of such buildings is defined as category III. Thus, the values of the elastic response spectrum in the period under examination were calculated, and the values of PGA were determined. The ULS of collapse was 0.453 g, the ULS of life safety was 0.331 g and the SLS for usability after a potential earthquake was 0.139 g.

Subsequently, the risk indicators at different limit states were calculated, as a ratio between capacity (results obtained from the VC model) and demand (the results being obtained in relation to the nominal lifespan of the building and the category of use) of the structure, and it was observed that these are for the most part less than one and constitute high-risk cases compared to those demanded by regulations, and therefore, it is essential to reinforce the structure (Tables 5, 6 and 7).

### 4.3 Preliminary Assessment of the Repair Work

The data obtained from the analyses was used to devise intervention strategies and develop a plan to reinforce the structure. The intervention plan foresees analysing various alternatives regarding the possible reinforcement or rebuilding of some or all of the parts in question, changing the structure by adding new stronger parts or by eliminating those that are particularly vulnerable, and, finally, introducing an additional structure, which would be fully able to resist the planned action. Different ways of intervening were examined, some traditional and others more innovative. It

**Table 8** Risk indicators—  
ULS after the repair work

$\alpha_u$				
	Pt dir. X	Pt dir. Y	P1 dir. X	P1 dir. Y
Minimum	1.38	1.26	1.76	1.33

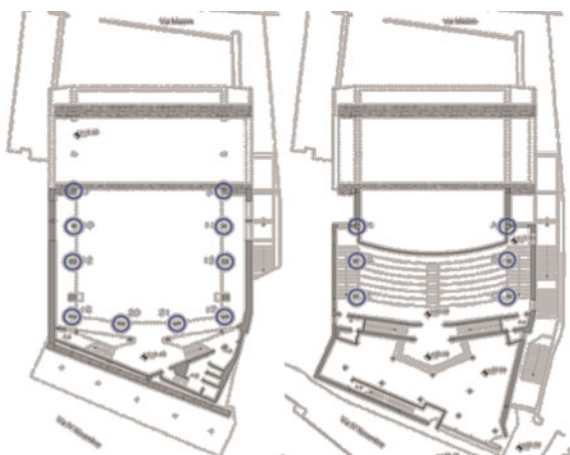
**Table 9** Risk indicators—  
SLS after the repair work

$\alpha_u$				
	Pt dir. X	Pt dir. Y	P1 dir. X	P1 dir. Y
Minimum	3.43	2.43	2.74	2.81

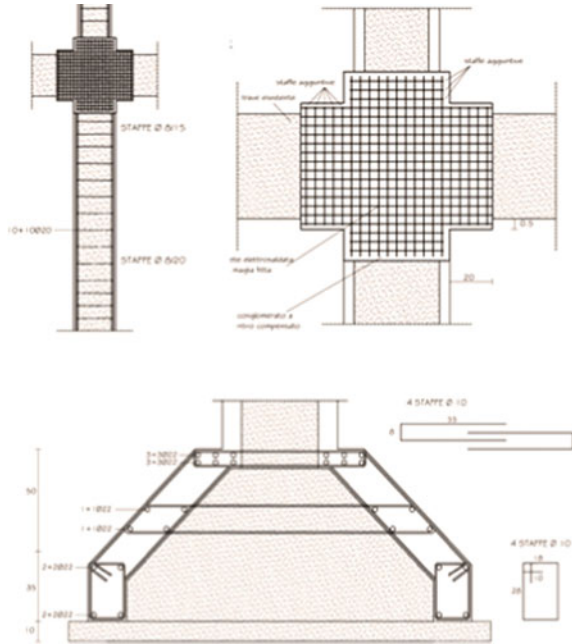
was necessary to consider the advantages, as well as the disadvantages of each type of intervention, in order to identify the methodology that will best solve the problems of the structure in question. For this reason, it was decided to use a traditional technique of local reinforcement, which involves cladding the structural elements in reinforced concrete, a method, which best meets the seismic, structural and architectural needs of the building.

This intervention requires an increase in the bearing capacity, the resistance to bending and shearing and the deformation capacity. The measurements were taken according to the requirements of the 2008 Italian building regulations, anticipating work on the pillars as well as on the joints and foundations.

In the new structural configuration, the analysis was conducted once again using the VC procedure, which showed that the seismic adaptation and all of the checks had been carried out satisfactorily and that the lack of longitudinal reinforcement had been corrected. The results of this analysis, in terms of risk indicators, are shown in Tables 8 and 9 (Figs. 16 and 17).

**Fig. 16** Circle and stall plans  
with the repair work

**Fig. 17** Cladding of the structural elements in reinforced concrete

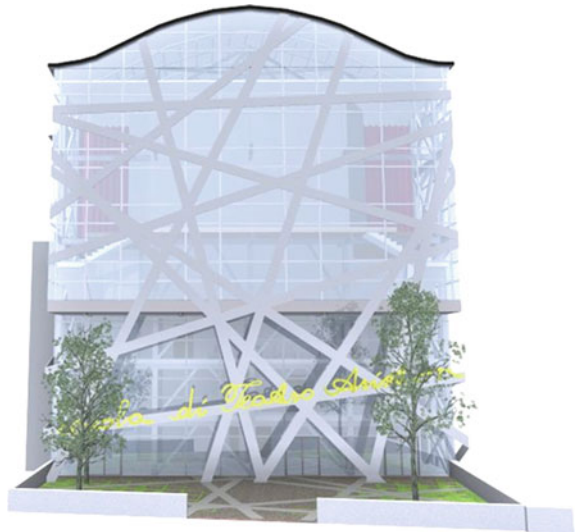


## 5 The Restoration and Improvement Project

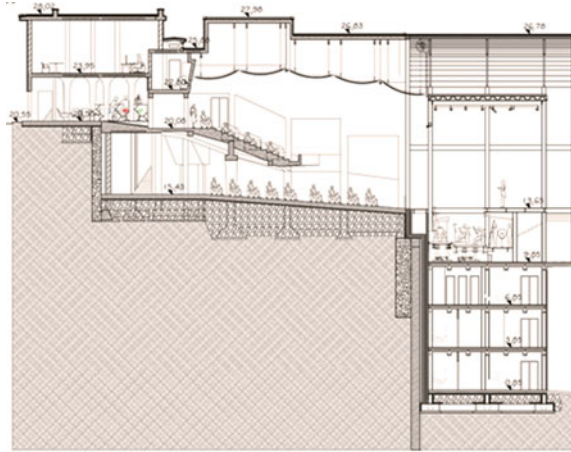
The restoration project is the result of the combination of several approaches. These approaches had to fulfil certain requirements relating to the building’s function and features. Furthermore, the different approaches were linked to various issues, which have meant a compromise had to be reached in choosing solutions deemed appropriate, both in terms of technology and style, in order to render the transition between the new and pre-existing parts of the building more or less noticeable.

The present structure of the Cinema Ariston, its history and the role it played within the city and within the network of cinemas, are all aspects, which have influenced the renovation plan. The aforementioned aspects have meant that the plan in fact aims to recreate the historical and cultural memory of the building, to preserve materials and existing parts of the building, and to propose a transformation that involves a change in the building structure. In this way, it was possible to preserve the existing spaces that were considered vitally important aspects of the plan.

The restoration and improvement project envisages a new role for the Cinema Ariston. The project aims to turn the building into a cinema again, and its potential use is increased by giving this “architectural ruin” a new-and-old purpose, a new identity in the form of a film theatre and a drama school (Figs. 18 and 19).

**Fig. 18** 3D model view**Fig. 19** 3D model view

The intervention strategy used is architectural integration that involves the completion and improvement of the existing building, by adding areas to create additional space to dedicate to activities, reusing the old space, which had been lost during the years of neglect, and at the same time improving the architectural form of the cinema. The new additional area is directly adjacent to the existing building, thus creating a sense of continuity and a change in appearance. This extension was designed using contemporary and innovative modes of expression and techniques, which interact well with the modern construction techniques of the building. This part of the building is intended for educational and leisure activities related to the drama school, a part of the building, which was simple to analyse in terms of

**Fig. 20** Cross section project

architecture and space, since there are no significant structural constraints. Yet, the analysis of this part of the building was also varied, because it required a degree of continuity with the existing building that had to be logical and consistent (Fig. 20).

The architectural expressivity used to create the “glass box”, a box made of steel and glass, encourages dialogue with the surrounding urban context by means of a game of reflections, light and colour, emphasizing the building’s brand new image. The decision to add a steel grid to the glass façade was aimed at recreating the inclusion of nature in architecture, in an artificial way.

### ***5.1 Project Architecture and Functions***

In line with the profound changes, which have affected performance venues in recent decades, it was decided that the building should be given several additional functions, to support the building’s main activity. These were to be areas for a snack bar, a bookshop and a video shop and administrative areas for the management of the complex. The choice in the positioning of such areas inside the building meant that practical spaces for the new activities had to be found. This search was based on a careful analysis of the building’s current conditions, from an architectural and stylistic point of view, and in accordance with ergonomic and regulatory standards. The main purpose of this analysis was to safeguard the original building, while maintaining and improving the building’s special features, and locating the drama school within the extension.

The design process was conducted from two different perspectives, but in parallel. One perspective was related to preserving and improving the existing building, while the other perspective was related to the content and technological design of the new part of the building. The project envisages how the different parts of the

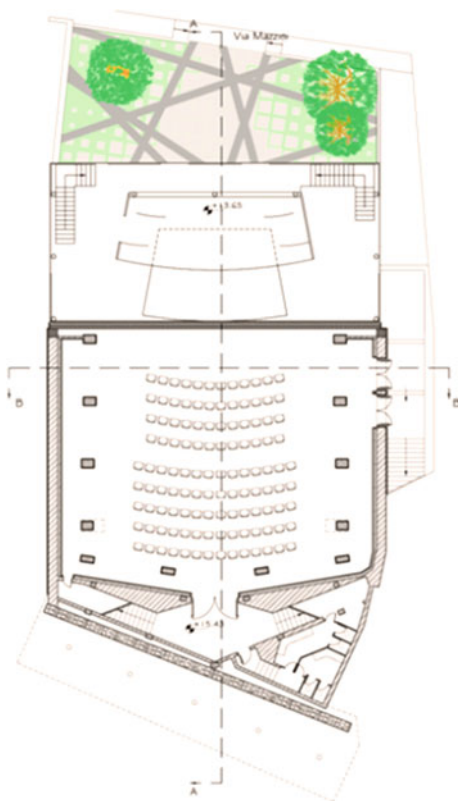
building will be divided, according to the physical layout of the building, in terms of area, organization and distribution of space (Figs. 21 and 22).

The existing part of the building is built on three levels and maintains the former subdivision of spaces, recreating the architectural spaces as they originally were, taking on a new connotation. The main entrance, the box office, the foyer and the bar are renovated on the ground floor. From here, it is possible to reach the circle and, by means of two symmetrically positioned flights of stairs, you can reach the stalls, on the lower level. A bookshop is planned on the landing, at the top of the stairs. Another separate entrance, from via IV Novembre, allows you to reach the first floor where there is the projection room, the administrative offices, a storeroom and toilet facilities.

The new part of the building, which houses the stage, stage facilities and the drama school, has a design, which draws attention to the consistency of the materials and the shape of the old building. In this way, we are able to offer renovation, which is compatible and uses forms of expression and contemporary language, which blend harmoniously with what already exists.

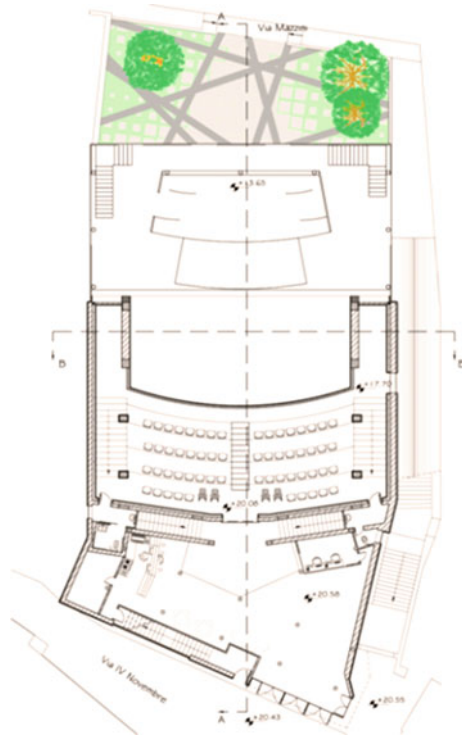
At present, if you look at the front of the cinema in Via Mazzini, you can see how nature has taken over and overwhelmed the building, becoming a part of the

**Fig. 21** Stall area and stage plan project

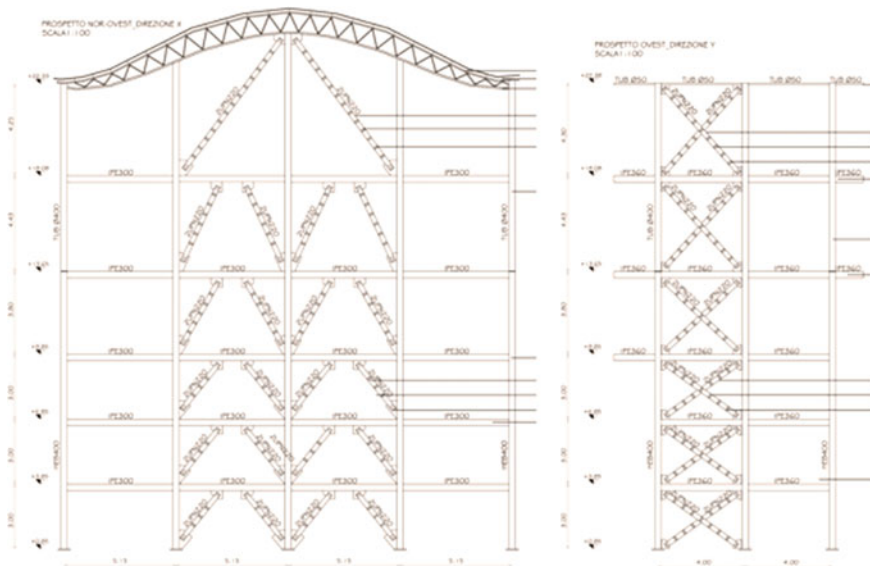




**Fig. 22** Foyer and circle area plan project



building itself, invading the spaces. Hence, the decision to place a steel grid on the glass façade, to recreate the inclusion of nature in the building, is an artificial way. The same redesigned cover, made of steel, resembles the curved shape of the existing cover and is joined to it by means of technology, which is efficient from a thermal, structural and seismic point of view. The area is mainly a vertical elevation and is divided into five levels, the first two of which are principally intended for educational activities, the third for extra facilities connected to the theatre and entertainment and the last two levels for performances and shows. It is only possible to reach this area from Via Mazzini, because, in the planning stage, it was considered necessary to differentiate between and separate the different activities, to make each one independent. The entrance is located in the area of Via Mazzini and has an outdoor courtyard, which is a “filter” area between the street and the building. It is a pedestrian-only area, intended as a green space in a highly built-up area. A special feature of the courtyard is the flooring, which consists of two different patterns at the same time. The main pattern is made up of square blocks, which gradually become smaller, while the natural green areas become larger, and this pattern ensures a gradual transition from buildings to nature and back again. On top of this is another pattern made of chromatically darker blocks, which create oblique strips that recall the pattern of the facade and indicate spaces for parking and general movement.



**Fig. 23** Structural project of the new

The organizational and functional plan of the drama school was drawn up with reference to similar buildings, as regards deciding the purpose and sizes of the interior spaces. Reception areas have been planned, together with areas for studying and rooms where practical activities can be carried out. The choice, in this case, too, to use materials, such as glass and steel, has allowed us to establish the insertion of a “box within a box”, with the clear intention of creating continuity of architectural expression. In order to maximize the potential of the complex, particular attention was paid to the shape of the new stage area. A new stage was built, where the old stage used to be, but its shape, size and facilities are different and an orchestra pit has been added (Fig. 23).

## 5.2 *Preservation Work and Structural Renovation*

For the restoration project of the existing building, it was decided that the materials, substance and image should be protected and preserved, to testify to the continuity with the past and to ensure the future of the building. Consequently, parts, which had been lost or adversely affected over the years, were preserved. Therefore, the building work consisted of a harmonious balance between preservation and innovation.

The projects of structural restoration, preservation and technological enhancement are varied, but nevertheless work in harmony with each other and are interwoven, with the aim of providing efficient solutions to the various problems identified. On the one hand, the necessary structural consolidation was assessed, in terms of structural and seismic safety, while on the other hand the intervention of preservation and improvement of the architectural work was assessed, in order to ensure an appropriate level of usability.

After a study of the causes of the building's decay, preservation measures were proposed, to guarantee the preservation of the existing building work and improve its quality and features. The building was run down because maintenance had never been carried out and the building had been totally abandoned and constantly exposed to the elements. It should therefore be pointed out that the restoration work, defined as reuse of the building, will ensure the preservation of the building and the elimination of the above causes of degradation. Some of the restoration work envisaged the removal (by hand) or taking away from the building site various materials, such as rubble and debris. As far as cladding materials and window frames are concerned, a proposal has been made to remove and subsequently replace them with a higher standard of materials, to increase the building's thermal, hygrometric and acoustic performance. The demolition of the previously bricked-up openings was necessary to recreate entrances and glass surfaces; this was done by removing the material that had been used and completing the masonry. Included amongst the work to be carried out on the surfaces is the removal of the patina, the removal of the deteriorated plaster, as well as of the stains and alterations in colour. This work is achieved by removing the material and the existing plaster and subsequently cleaning the surface and dehumidifying the wall to make it possible to apply the new plaster coating, which can then be painted. Considering the damp in the part of the building most exposed to atmospheric, chemical and external agents, checks of this area are to be carried out. Additionally, the old plaster will be removed, the new plaster will be applied and the building will be closed off thanks to the planned extension. The renovation of the stuccoed surfaces of the pillars in the foyer was also foreseen, using the original technique, a technique that will be repeated for the finishing of the pillars and decorations in the circle.

Finally, in order to repair the only crack that has been detected, which is the level with the intrados of the circle, a fracture that has stabilized over time, holes are to be made at regular distances near the crack; in this way, cement compounds can be injected through small tubes after sealing the surface.

The overall objective of reinforcing a building is achieved by intervening on the structural elements of the building. Such building work has the effect of increasing the strength of the elements of the building and reduces and redistributes the stress that the structure is subject to.

After analysing the structural state of the building during the diagnostic phase, it emerged that the structure has significant shortcomings in terms of seismic behaviour, in relation to the poor provision of longitudinal reinforcement in the structural parts, which, therefore, reach the point of collapse, analysed in the simulation

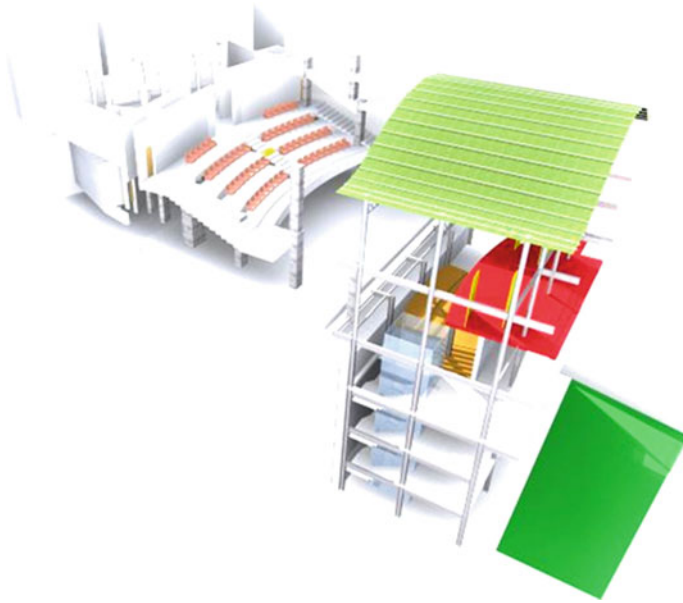
phase, with breakage caused by bending. In addition, considering the need to preserve the existing building and avoid altering its shape and structure, it was decided that it was best to perform a minor procedure in keeping with the design requirements. Thus, the best solution was to clad the pillars in reinforced concrete. Such a strengthening technique necessitated work not only on the pillars on which it had been decided to intervene, but also on the connecting parts, such as the pillar–beam node and the foundations. Another proposed aspect of the work, and one which is essential for buildings in seismic areas, regards the connection of the foundations, by connecting beams in both directions, both longitudinal and transversal.

Technological interventions proposed both on the existing and new building aim to improve the building's thermal characteristics, as well as its resistance to damp and water. The work proposed on the horizontal roofs involved the construction of an inverted roof, suitable for a cold, but mild winter climate and warm, dry summer, typical of the city of Potenza. The roof is insulated and waterproofed with a protective layer placed under the insulation and separated from the latter by a layer of non-woven fabric. As regards vertical elements (doors, windows and walls), insulation from the outside proved to be the only answer, which could solve the problems associated with a poor design because of the degradation detected, simultaneously guaranteeing a high level of waterproof protection, insulation, correction of thermal bridges and condensation levels, as well as protection from degradation caused by the elements. With regard to the new area, the technological project also includes an inverted roof, a glass panel façade and a floating floor to provide acoustic insulation for the classrooms to be used for the drama school's activities and a turf area for the entrance courtyard, which is a green space inside a densely built-up urban area.

### ***5.3 The Extension***

The design phase of the extension, aimed at improving the quality and features of the building, besides solving problems of a practical nature and problems related to the division of space, represented the fundamental phase for defining a renovation project that not only preserved the existing building, but also fulfilled other needs. This phase highlighted certain problems related to the completion and layout compared to the existing building. The structural and technological choices made in this phase manage to satisfy the need to create a connection with the existing building, without, however, appearing outmoded. For these reasons, the decision to use a contemporary form of expression, using materials, shapes, layout and features that are different from the existing ones, but compatible and in some cases complementary, has proved to be the right architectural compromise.

A complete plan was drawn up with a continuous connection between the composition, technology and also importantly, static reinforcement, in which no



**Fig. 24** 3D model: the existing building and the extension

aspects were favoured over others, but the choices made were the result of logical and rational analysis (Fig. 24).

## 6 Conclusions

The various issues covered in this analysis and research have made it possible to develop a complex multidisciplinary approach, which has enabled the formulation of important final considerations.

Despite being abandoned for many years and despite not being the current subject of restoration or renovation projects, the Cinema Ariston has nevertheless revealed interesting features and potential.

The historical and cultural importance, which the cinema still possesses, required a conscious and direct approach to the development of a renovation project capable of meeting the needs of the building itself and the community.

Solutions were proposed during the design phase, to guarantee an increase in the building's uses and functions, and these are sufficient to allow us to talk of a new identity for the building, thus projecting the Cinema Ariston towards the future. Furthermore, providing the old part of the city with an important meeting point and landmark would inject new momentum into a revival of the city centre, which is currently lacking in facilities, services and places for cultural and social events.

## References

- Acito L (1999) Il Cinema-Teatro Duni di Matera. Un'architettura moderna da tutelare, Libria, Melfi
- Bocca P, Cianfrone F (1983) Le prove non distruttive sulle costruzioni: una metodologia combinata. In: L'industria Italiana del Cemento, Rome
- Caniggia G, Maffei GL (1979) Composizione Architettonica e Tipologia Edilizia. Lettura dell'Edilizia di base, Marsilio Editori, Venice
- Del Monte E, Lavacchini G, Vignoli A (2004) Modelli per la previsione della resistenza a compressione del calcestruzzo in opera. Ingegneria Sismica n 3
- Di Leo A, Pascale G (1994) Prove non distruttive nelle costruzioni in c.a.. In: Il Giornale delle Prove non Distruttive n 4
- Dolce M, Moroni C (2005) La valutazione della vulnerabilità e del rischio sismico degli edifici pubblici mediante le procedure VC (vulnerabilità c.a.) e VM (vulnerabilità muratura). In: Atti di Dipartimento - vol. 4 (2005), Department of Structures, Geotechnical Engineering, and Applied Geology at the University of Basilicata, Potenza
- Gasparik J (1992) Prove Non Distruttive nell'Edilizia. Quaderno Didattico AIPND, Brescia
- Giacchetti R, Bufarini S, D'Aria V (2005) Il controllo strutturale degli edifici in cemento armato e muratura. EPC Libri, Rome
- Masi A (2005) La stima della resistenza del calcestruzzo in situ mediante prove distruttive e non distruttive. In: Il Giornale delle Prove non Distruttive Monitoraggio Diagnostica
- RILEM, NDT 4 (1993) Recommendations for in situ concrete strength determination by combined non-destructive methods. Compendium of RILEM Technical Recommendations, E&FN Spon, London
- UNI EN 12504-4 (2005) Prove sul calcestruzzo nelle strutture - Parte 4: Determinazione della velocità di propagazione degli impulsi ultrasonici

# Plumbing System's Pathologies Based on the Record of Technical Assistance and Design Procedures

Ruany Ferreira, Leticia Carvalho and Marcus André S. Campos

**Abstract** During many years, plumbing system has been the leader at the list of technical assistance complaining. Many factors may cause these problems: weak design, uncontrolled execution, materials or inappropriate use of the sanitary fixtures. By analysing the technical assistance records, it is quite hard to verify which problems are related to flawed construction procedures. That way, this paper intends to establish a routine to analyse those records, identifying those related to weak design of the plumbing system and improving its process that may have been causing some defects. To do that, all the complaining records of a construction company of the city of Goiânia were analysed and classified to the most probable cause of it. In parallel, plumbing system design of three buildings was analysed and verified all the nonconformities of the Brazilian standards that can cause pathologies at this system. Once identified, all the nonconformities were compared with records of the technical assistance. The results showed that most of the problems related to the technical assistance were really happening due to inappropriate execution, but the weak plumbing design contributes to a high percentage of the problems. Some of the problems are caused by the lack of commitment to the Brazilian standard procedures or the poor details. We expected to help the learning process that can be withdraw from the technical assistance complaining, improving the product that the company delivers.

**Keywords** Building defects · Technical assistance · Plumbing system

---

R. Ferreira · L. Carvalho  
School of Civil Engineering, The Federal University of Goiás, Goiânia, Brazil  
e-mail: ruany.fp@gmail.com

L. Carvalho  
e-mail: leticiacarvalhomo@gmail.com

M.A.S. Campos (✉)  
Faculty of School of Civil Engineering, The Federal University of Goiás, Goiânia, Brazil  
e-mail: marcussiqueira@yahoo.com.br

## 1 Introduction

Globalization growing trends in the past years promoted important changes on the civil construction area in Brazil, especially increasing competitiveness among companies. The opening of the civil construction market to new technologies, the demand for modern goods and the reduced amount of skilled workforce prompted the emerging of pathologies at the delivered buildings (Matos 2010; Fantinati 2008).

Along with the changes in the construction market, the customers' requirements increased. They have developed growing knowledge about their rights related to the quality of products and services. Moreover, the new Brazilian Civil Code, the Consumer Protection Law and the new performance requirements support customers, who require minimum building performance.

By following these remarks, companies understood the importance to look for techniques and to establish systems that would improve the processes continuously, in a way where customers' requirements would be fulfilled and the company would guarantee its market share.

Processes of maintenance of technical support and the method of post-occupancy evaluation (POE) are essential tools on the evaluation of the quality of the constructed site. They analyse the effectiveness of processes and verify possible solutions to flaws on them (Correa and Costa 2007; Cupertino 2013).

Based on the database research of technical assistance departments, plumbing systems are related to the main causes of post-occupancy pathologies. They derive from flaws in use, execution, material, planning and project. A research developed by Cupertino (2013), in a 30-year construction company of buildings, demonstrated that 28 % of construction flaws were directly associated with leakage, clog, maintenance failure and flaws in hydraulic and sanitary facilities.

Considering the defects mapped, an analysis of the main requirements of these facilities is important. This analysis was based on rules and main defects related to execution. The rules were analysed based on the orientation of each facility, their specific characteristics and their function. A fundamental factor to map the causes of defects in hydraulic and sanitary facilities included the study of the Brazilian standards. This was linked to the knowledge of possible pathologies and the guidance to the removal or reduction of them.

## 2 Research Methods

To reach the goal established, we used the following method.



### 2.1 Data Collection

Following the theoretical foundation, data were collected from the department of post-occupancy from a local construction company, hereby referenced as company A. The data consisted of customers’ requests due to the detected defects after the delivery of the unit. At the company A, the requests were made by e-mail, in which customers described the verified problem. As the technical assistance department receives requests from all systems related to the enterprise, the e-mails were sorted. The complaints related to flaws from the hydraulic and sanitary facilities were selected, for instance leakage, odour, foam, and among others.

The company “A” provided data from the start of January up to September, in 2013, taking into account an average of 600 requests. The data are three enterprises with their quantities and units, issue and data collection periods presented in Table 1.

The access to these requests was important to the development of this paper since most companies are not willing to provide them. This kind of data is related to the real conditions of planning, control and quality of design, material and constructive systems adopted.

The 600 records were evaluated, and the one that was related to plumbing systems was separated, totalling 194 records.

### 2.2 Case Study

The case study was divided into two stages. The first step was the classification of requests according to the possible causes and subsequent analysis of the projects to verify the classification performed.

**Table 1** Data analysed enterprises

Enterprises	Housing units	Issue date	Data collection period	Standard	Building area (m <sup>2</sup> )
A	300	February 2012	31/01/2013	Medium	41.480,77
			–		
			25/09/2013		
B	228	April 2013	15/05/2013	Medium	49.081,07
			–		
			22/09/2013		
C	272	October 2012	31/01/2013	Medium	27.197,24
			–		
			25/09/2013		

### **2.3 Data Rating**

Following the research data of the company A, the plumbing system complaining was ranked and then a spreadsheet from Microsoft Office Excel was created. For each request, a percentage was assigned. This percentage was related to the probable causes of pathologies listed, concerning project, execution, materials or use. The purpose of this ranking was to identify and list the main requests related to hydraulic and sanitary facilities and quantify the possible causes related to the pathologies.

### **2.4 Design Analysis**

Once identified, it was checked the most frequent defects and those that were representative. After that, it was verified which ones could be caused by design procedures. Once the plumbing system design was available, they were compared with the Brazilian standards to confirm whether they had met all criteria required by regulation, or whether the pathological manifestation may have been caused from a failure of this design.

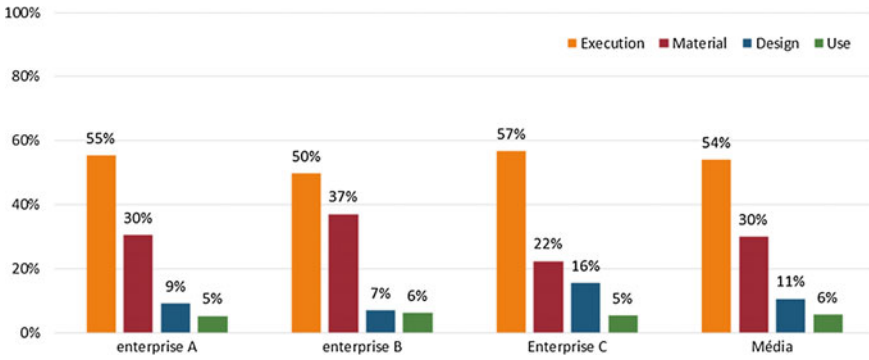
### **2.5 Data Analysis**

Following the data analysis and the study of the available material from the companies, this research aimed at confirming the designated causes to the pathologies on the data ranking. Possible errors were identified and, consequently, the real causes.

The data collected in the project analysis will be faced with the records, and following the identification of the causes of the pathologies, the ranking was reviewed to confirm the rule that the design can have at the defects related.

## **3 Results**

According to the method aforementioned, the technical assistance requests related to hydraulic and sanitary facilities were listed. It amounted to 194 requests from 3 enterprises. Following the analysis of their possible causes, they were ranked by assigning a percentage to their possible causes, among execution, material, design or use. The result achieved is shown in Fig. 1.



**Fig. 1** Most likely causes of the plumbing system pathologies

On the three enterprises analysed, the main cause to recorded pathologies was the flaw on the execution process, with an average of 54 %, followed by flaws on material, 30 %, design flaws, 11, and 6 % due to the user’s bad behaviour.

Among the numerous requests of technical assistance, the following pathologies were identified: leakage at the ceiling; clogged sink and drain; leakage at the taps; odour; flushing problems; leakage at the sink drain pipe; leakage at the toilet; insufficient pressure on supply devices; leakage at the shower; dampness in walls; lack of materials; clogged toilets; leakage at the water metre; valve problems; lack of water supply in any water device; problems with tap outflow; problems at the sink drain pipe; inadequate grease trap; faulty water pump; shower that is not aligned; noisy flush; missing drain; and continuous water interruption.

The requests were grouped according to the number of reported pathology. According to Fig. 2, the six pathologies aforementioned (leaking roof, clogged sink and drain, leaking tap, odour, flush problems and leaky sink drain pipe) are responsible for around 70 % of the total complaints from users.

The main defects that were more representative were as follows: water penetration at the ceiling; clogged sink and drain; leakage at the taps; odour; problems at the close coupled cistern; and leakage at the sink drain pipe. Then, it was conducted an analysis of the design of the enterprises studied at this research to verify flaws that might have been causing these problems.

First, we prepared a checklist with the items of the designs that should be verified for each of the six groups of defects reported. They were guided by the possible causes of them and listed the items should be investigated, as shown in Table 2.

It is worth to say that there are several design elements that can indirectly affect the pathological manifestations due to its influence on execution, such as the quality of the layout, the visual quality of the product or the limitations imposed by the architecture.

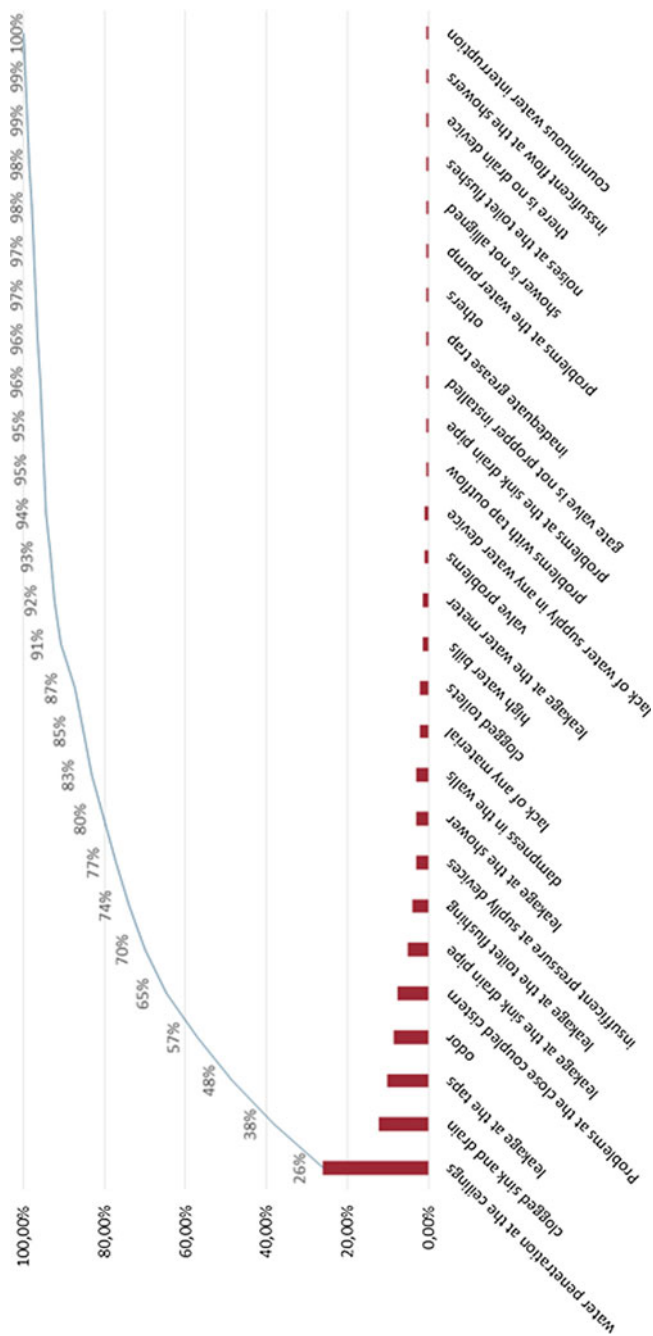


Fig. 2 Main reported requests related to hydraulic and sanitary facilities

**Table 2** Data analysed enterprises

Defects	Possible causes	What should we verify at the design?
Water penetration at the ceiling	Inappropriate connection with pipes and fittings Break of pipes or fittings Inappropriate position of drain floor Lack of waterproofing User’s bad habits	To verify whether tests are made on the plumbing system right after the service done To verify whether the waterproofing is done at the shower box area
Clogged sink and drains	Cloggings caused by construction spoils Inappropriate slope at the execution Bad habits of the users	To check how they handle the construction spoils To verify how they control the slope To check the slope determined at the design
Problems at the close coupled cistern	Low-quality material Inappropriate execution	To verify the brand of the material To follow the execution process to check if it is standardized
Odour	Use of two drain device, without siphon at the bathroom Inappropriate design related to the ventilation system	To verify whether there is at least one siphon at the bathroom To check the plumbing system design
Leakage at the taps	Low-quality material Inappropriate execution Bad habits of the users	No, check items at the design
Leakage at the sink drains pipe	Low-quality material Inappropriate execution Bad habits of the users	No, check items at the design

### 3.1 Water Penetration at the Ceiling

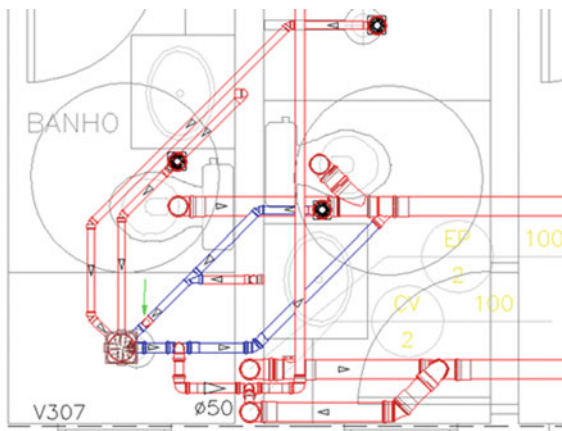
The water penetration at the ceiling is the defect that received the largest number of complaining, being responsible for 26 % of the total.

During the analysis of the design, we observed some nonconformities that might have been causing the defect aforementioned. Aspects that we found at the design of the system’s layout could be harmed in order to hinder the enforcement procedure, contributing indirectly to the occurrence of the event. Figure 3 illustrates an example of a track that may hinder the implementation of cold water pipes and sewage, which could cause problems in performing the connections, facilitating possible defects associated with leakage at the ceiling.

### 3.2 Clogged Sinks and Drains

The clogging of drains and sinks which is a frequent defect complained by the users at the technical assistance is not caused only by the construction waste debris, as

**Fig. 3** Conception of the trace



might be supposed. One of the major factors that can lead to frequent clogging is the connections used in pipes and deviations from the prescribed slope.

From the point of view of the design, several nonconformities that could cause this type of defects were found. The first refers to the horizontal deviations. According to the orientation of the Brazilian standard about drainage plumbing system, the horizontal deviations, when necessary, should occur with a central angle less or equal than  $45^\circ$  (ABNT 1999).

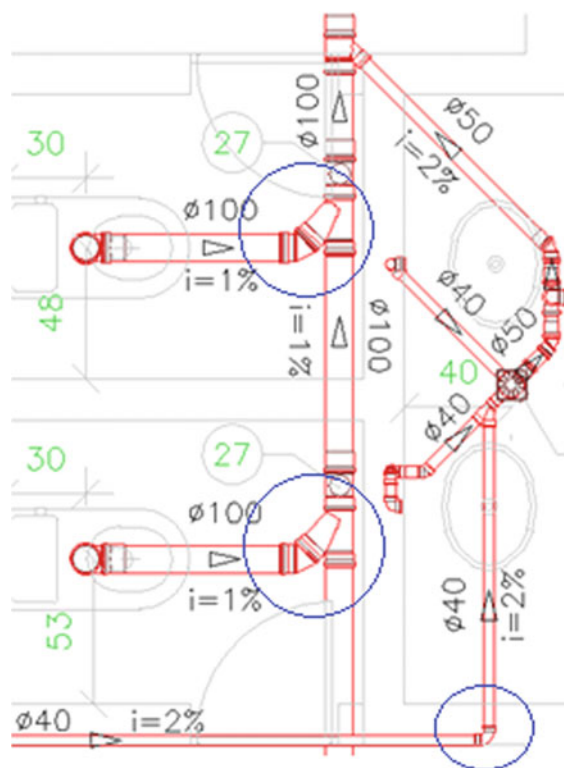
The Brazilian standards also state that all horizontal sections of the drainage plumbing system must allow the gravity outflow. So when the trace of the tubes presents deviations at  $90^\circ$ , the effluent is facing a great pressure drop, so that there is difficulty in the flow, making it slow and giving the impression that there is a clogging of the system. The slopes also used influence directly in the flow, and it is related to the diameters selected for use.

When we analysed the design of the drainage plumbing system, we could verify that all of them were indicating the slope of the tube correctly, according to the Brazilian standards. However, in various graphic elements displayed in the design, it can be observed deviations over  $90^\circ$ , as shown in Figs. 4 and 5.

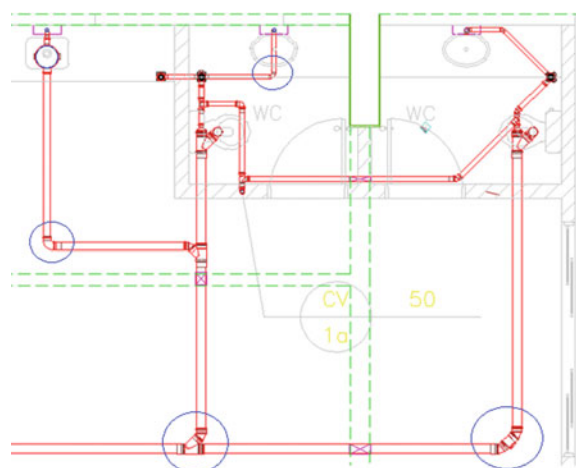
This  $90^\circ$  deviation occurs all over the design, as shown in Fig. 4, where it is possible to identify the drainage tubes of the restroom located on the ground floor of the building. We can notice that the water closet toilet is connected to the horizontal branch of the building through a  $45^\circ$  curve coupled to a  $45^\circ$  junction which forms a deviation of  $90^\circ$ . In the lower part of this same figure, there is a 40 mm pipe, which also has a deviation of  $90^\circ$ .

This solution continues to be repeated all over the building as shown in Fig. 5 (ground floor). Once it is frequent, we concluded that this is causing most of the clogging.

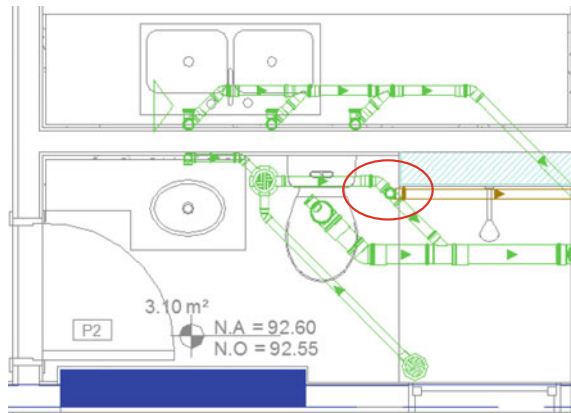
**Fig. 4** Horizontal deviations of 90°



**Fig. 5** Horizontal deviations of 90°



**Fig. 6** Horizontal deviations of  $45^\circ$ , according to the standard



This could easily be avoided by replacing the use a  $45^\circ$  junction in all horizontal deviation, as shown in Fig. 6.

Another situation we found at the original design is the use of a tee connected to the stack for receiving wastewater from a floor drain, as shown in Fig. 7. This issue is not treated a nonconformity item, once the Brazilian standard allows the use of angles up to  $90^\circ$  to make the connection to the horizontal tubes to the drop tube. However, the NBR 8160 (ABNT 1999) assumes that the sanitary drainage plumbing system must allow a fast run-off of drainage outflow which cannot be answered by the analysed item, once the distance between them is only 25 cm. Thus, there is a great possibility of return of the sewage through the grid of the drain. This could easily be avoided by replacing the use of the tee by a  $45^\circ$  junction as shown in Fig. 8.

Another design failure is the proper specification of the slope that the horizontal tubes should have as well the ways to verify their execution. Fig. 9 illustrates an example of the slope of the floor drain executed in opposite direction of what is supposed to be.

### 3.3 Odour

By dealing with odour, often, the design is seen as the main cause, so that there is a series of regulatory requirements which must be met, about the upstream and downstream vent. Once the design is analysed, we verified that a poor venting causes this defect, once several nonconformities were verified.



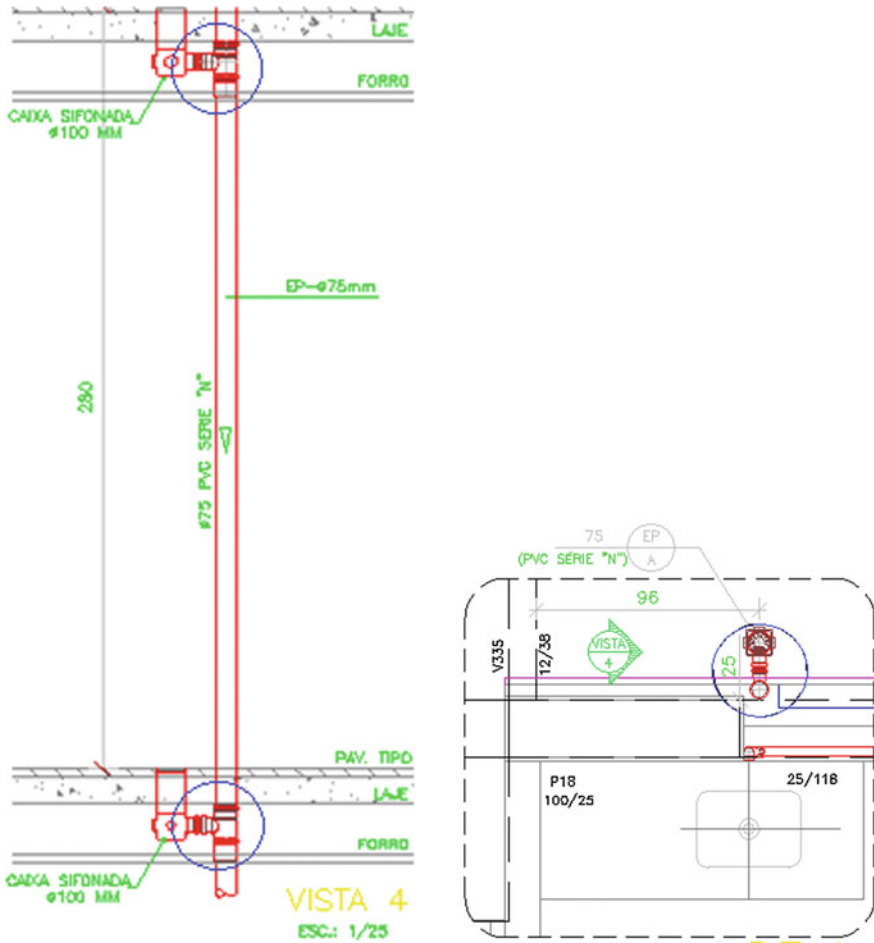
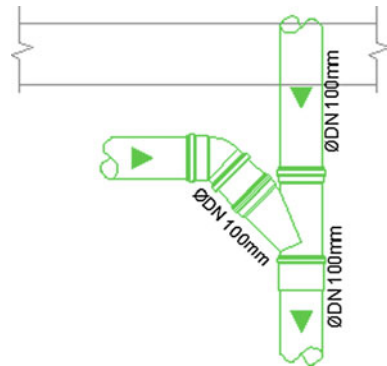


Fig. 7 Detail of siphoned box and sewage downpipe connection

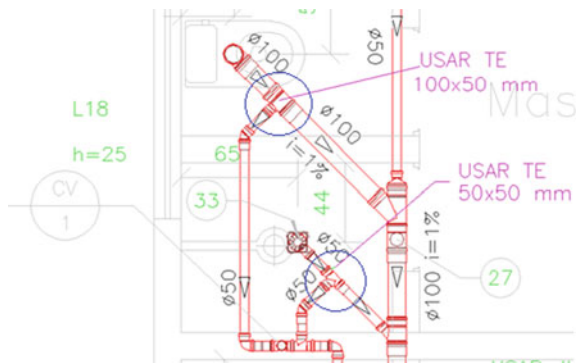
Fig. 8 Sewage downpipe connection with a 45° junction





**Fig. 9** Opposite slope of the siphoned drain

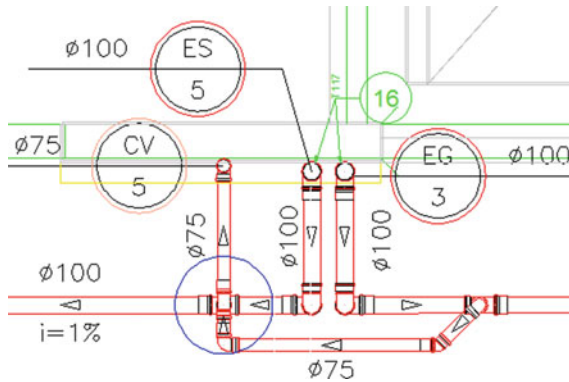
**Fig. 10** Ventilation branch at the same level of the sewage pipes



According to the requirements of the NBR 8160 (ABNT 1999), the sanitary plumbing system should be designed to avoid the access of sewage to the venting subsystem, except in rare cases when, even so, it is indicated that all vent piping is installed with a minimum slope of 1%. When the downstream venting is in the same level of the sewage pipes, it allows the sewage to get into the ventilation tubes, as shown in Figs. 10 and 11.

In Fig. 10, there is a 45° joint  $100 \times 75$  mm to the vent system. This will allow the sewage to get in the vent plumbing system. It is possible to identify that the venting is in the same level of the sewage tubes.

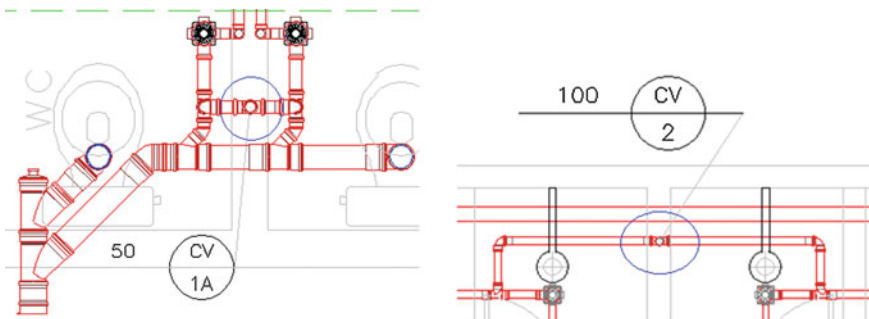
In Fig. 10, there is two tees that are rotated in the wrong direction, what does not allow the vent to be in an upper level of the sewage system.



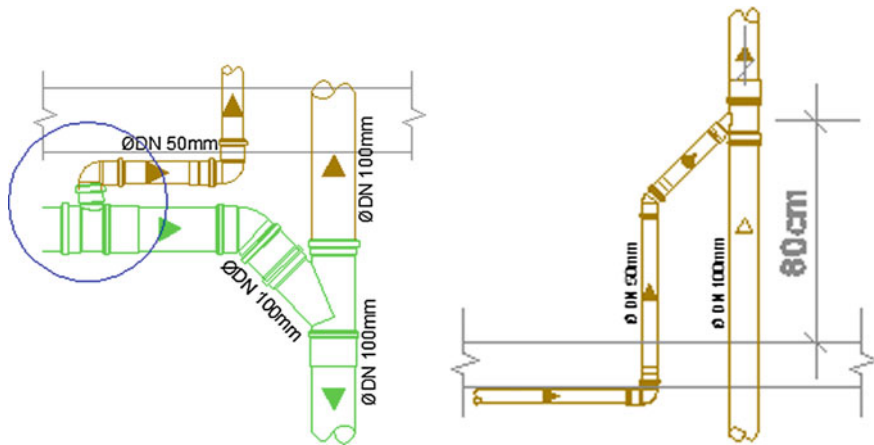
**Fig. 11** Ventilation branch at the different level of the sewage pipes

In Fig. 11, there is a floor drain and its connection to the venting system. With this kind of connection, it is possible that the sewage flow gets into the venting tube, what it might cause the odour some users are complaining. In Fig. 12, it shows the solution made at the design.

Furthermore, it becomes clear when reading the standards that the connections from the upstream venting branch to the upstream venting column must perform by a 45° junction and a 45° hub. When it held in a horizontal pipe, it must be performed above the axis of the pipe, raising the venting pipe a distance of 0.15 m or more above the overflow level of the water of the highest sanitary appliances for it ventilated, before turning to another ventilator tube, as shown in Fig. 13. When there is no possibility of attending this item due to insufficient vertical space, the norm dictates that smaller angles can be adopted, with the ventilator tube connected only by junction 45° to the respective extension of sewer and installed on your initial stretch minimum slope 2 %.



**Fig. 12** Inappropriate ventilation loop



**Fig. 13** Appropriate venting system

In Fig. 14, we can identify other non-compliance. In this case, there is the use of a direct connection of the stack to the venting system, thereby dismissing an extension venting. According to NBR 8160 (ABNT 1999), when you cannot ventilate the branch of the water closet, the venting should be at the slack, right after the fitting this connection, as exemplified at Fig. 15.

### ***3.4 Leakage at the Taps, Problems at the Water Closet and Leakage at the Sink Drain Pipe***

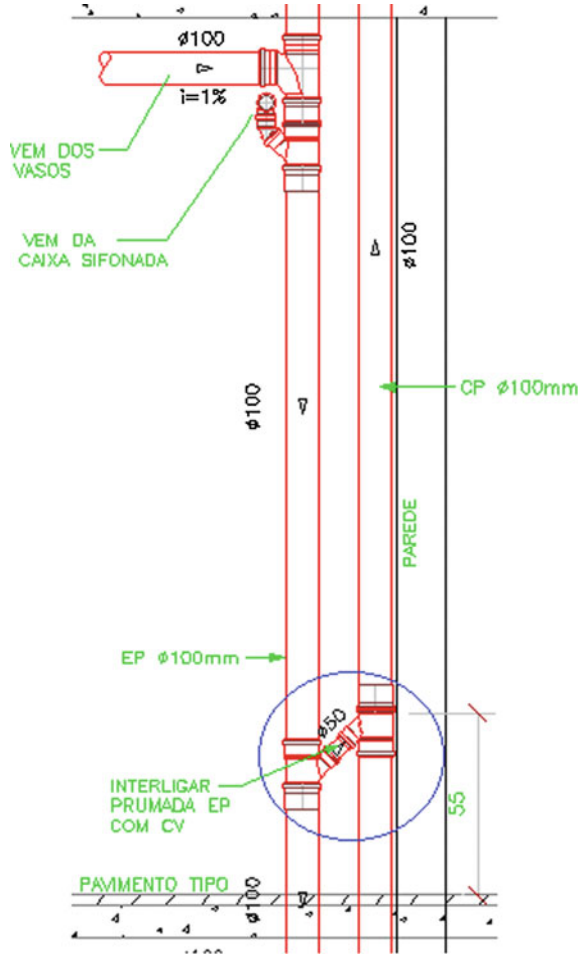
The design of the plumbing system cannot be the cause of these defects, once they probably are caused by some failure of the execution process or material.

### ***3.5 Issues in Accordance with the Brazilian Standards but not Indicated to Proceed***

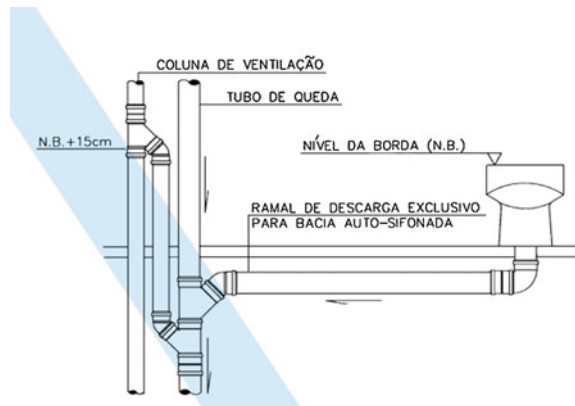
Some concerns were verified during the design analysis. These concerns were in accordance with the Brazilian standards, but, usually, they are not indicated.

The first point is the location of the drain floor. Usually, these devices are in the centre of the shower area, as shown in Fig. 16. This position may cause problems to implement the incline of the floor; its position may result in a discomfort in the users; and it also can break easily. The solution is to insert the drain in the corner of the shower area, as shown in Fig. 17.

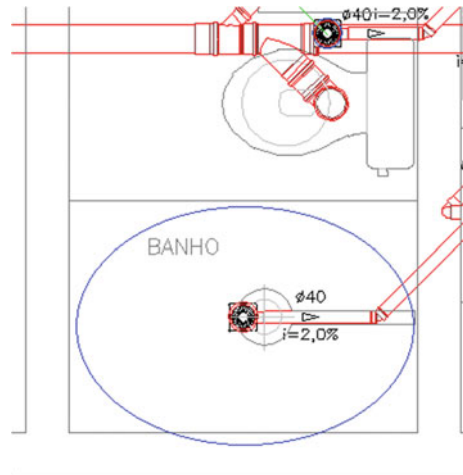
**Fig. 14** Connection of the stack to the venting system



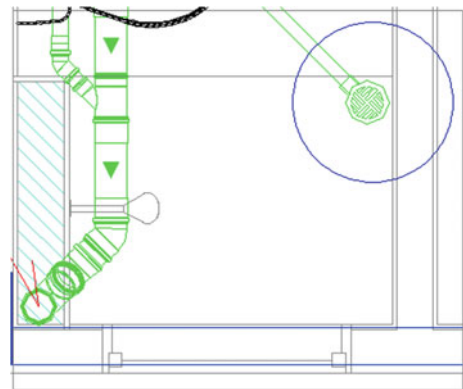
**Fig. 15** Connection of the stack to the venting system according to the standard. Source ABNT (1999)



**Fig. 16** Location of the drain floor in design



**Fig. 17** Correct location of the drain floor in shower area



### 3.6 Analysis of the Results

Nonconformities were identified using the plumbing system's Brazilian regulation as a parameter. We noticed that other items were still compliant related to the standards but not advised related to the practical point of view. All failures identified were recorded and were detailed below.

By analysing the plumbing system design and comparing it with the reports of technical assistance, we observed that probably three of the most reported defects had their cause directly attributed to a poor design. The design analysed did not meet some of the Brazilian standard requirements, and there is no communication between the service department and the construction site. This lack of communication causes the repetition of defects. This type of problems, in addition, to generate unnecessary expenses, affects the company's image with its customers.

**Table 3** Final Evaluation of the probable causes of the defects

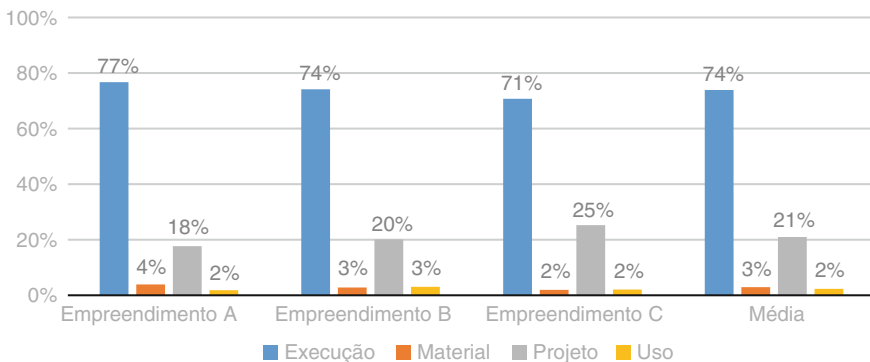
		Execution (%)	Material (%)	Use (%)	Design (%)
Water penetration at the ceiling	Initial	85	10	5	–
	Final	90	5	–	5
Clogged sinks and drains	Initial	60	–	20	20
	Final	50	–	5	45
Odour	Initial	25	25	–	50
	Final	20	–	–	80

The initial and final probable cause’s percentage was modified. Based on the information obtained, there was a new assignment, thus increasing the participation of design failure in reported defects in requests for technical assistance. The results are shown in Table 3.

The final result showed a higher participation of the design process at the defects presented for the technical assistance. At the original analysis, we attributed an average of 11 % design cause. After what we found at the design, we raised this value to 21 %. In Fig. 18, there is the new distribution to the defect’s causes.

The procedure that could be used by builders to aid and control of plumbing systems ranges from the organization of the requests received for the technical assistance to final analysis of the possible causes of the observed defects. It is important to emphasize the importance of feedback from the technical assistance department with the performed analysis and repairs in order to promote continuous improvement of the processes used by the company. As shown in Fig. 19, we propose the necessary actions to be implemented by each construction company, according to its existing features and procedures.

Initially, it is important to analyse the technical assistance department. Upon receiving requests from customers via e-mail, spreadsheets should be developed so these requests can be recorded and analysed. Then, an initial analysis is performed



**Fig. 18** Most likely causes of the plumbing system pathologies after reported reclassification

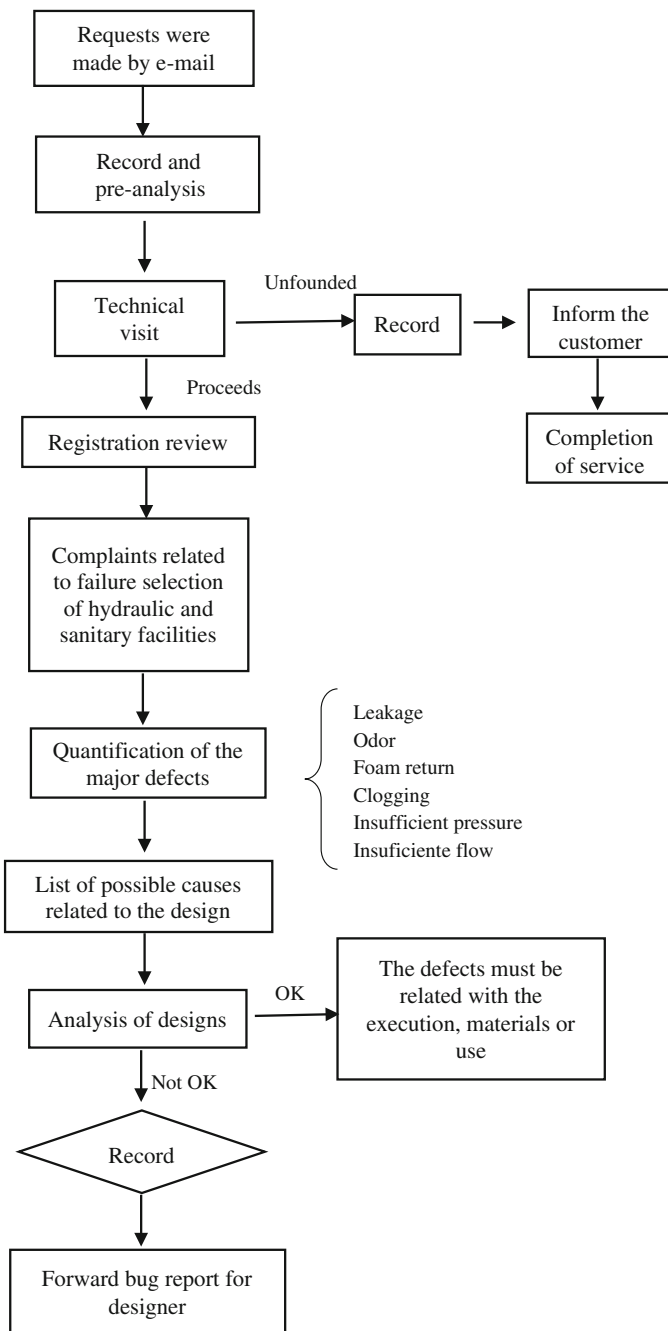


Fig. 19 Diagram



regarding the subsystem in which there is a defects, for example plumbing systems, wall covering, window frames, floor covering, electrical installations, roof coating, paint, plaster lining, shutters, roofing, waterproofing, windows, cleaning, special facilities, granite, cabinets and pool liner.

For each affected subsystem, there will be a list of pre-established events and it can be implemented according to the future events and may previously contain the following items: leakage, odour, foam return, clogging, insufficient pressure and insufficient flow.

The request, after recorded, will be validated by a qualified professional, who will visit the place where defect occurred, verifying with the customer, what exactly the defect is. At this point, it is essential to see that the responsible for technical visit fill out a form with the relevant data from the request, which can even be generated from pre-spreadsheet analysis described above. These records should be filed by the company.

With the initial results, we can check the recurrence of events. This can be done with the derivation of a spreadsheet that lists all the items for each subsystem and accounts for the technical assistance requests.

From the recurrence of events, the next step is to check the cause of each. For each defect, there is a list of possible causes, which can also be implemented with the maturing of the particular procedure of analysis of each company. These lists, as shown in Table 2, aim to direct the search for the cause of the identified event, thus providing a greater focus on the study of the projects.

At the end of the analysis, there is sufficient data for decision-making and re-evaluate the company responsible for hydro-sanitary projects or assumes that defects are related to other parts of the project such as running, materials or use.

## 4 Conclusions

This paper presented a case study about pathologies related to hydraulic and sanitary facilities. This is the subsystem affected with the greatest rate of technical assistance requests. This paper aimed at identifying possible flaws in plumbing system design processes.

The procedure realized here should be used to the construction companies to aid and control of plumbing system. The actions will go from the complaining data's organization of the technical assistance until a rigorous analysis of their causes and the best way to fix them. It is important to emphasize the importance of creating a feedback process from the technical assistance department to the design department and the construction department, with the performed analysis and repairs, in order to promote continuous improvement of the processes used by the company.

This paper studied the rule that information of the technical assistance can bring to improve the construction. By recognizing some design flaws that were happening during this process, we noticed that most of the defects related could be avoided by a critical analysis of the design or even if the information could go to the

construction department, what could repair the design flaws. These defects would bring extra costs to the construction company, but it also would tarnish its image to society, what can take years to go back to normal.

It is necessary that the construction company takes actions towards to mitigate the exchange of information among technical assistance, design department and construction departments, what would affect not only in the design process but also in the execution process and the material management (purchase and storage).

The next step of the research is to analyse how these two actions impact at the defects reported and how to allow the knowledge created at the technical assistance department can improve the entire construction process.

## References

- ABNT—Associação Brasileira de Normas Técnicas (1999) NBR 8160: Sistemas prediais de esgoto sanitário- Projeto e execução. Rio de Janeiro
- Costa HG, Correa PS (2007) Integração do método ahp à avaliação pós-ocupação (apo) para mapeamento de graus de importância de Quesitos da qualidade. Simpósio Brasileiro de Pesquisa Operacional, Fortaleza, Ceará
- Cupertino DC (2013) Análise de solicitações de assistência técnica em empreendimentos residenciais como ferramenta de gestão. Dissertação (Mestrado). Universidade Federal de Goiás, Escola de Engenharia Civil, Goiânia, Goiás
- Fantinatti PAP (2008) Ações de gestão do conhecimento na construção civil: evidências a partir da assistência técnica de uma construtora. Dissertação (Mestrado). Universidade Estadual de Campinas, Faculdade de Engenharia Civil, Arquitetura e Urbanismo, Campinas, São Paulo
- Matos AD (2010) Planejamento e Controle de Obras. PINI, São Paulo

# Cracks of Masonry Partition Walls in Multifloor Building: Case Study

A. Casado Lordsleem Jr.

**Abstract** The masonry partition walls cracks of multiple floors buildings, particularly, have been worrying users and technical community. The masonry partition walls use requires ability to absorb stresses from deformable structures. As a result, the of the masonry partition walls ability to withstand the imposed deformations requests is overcome, resulting in cracks. This paper describes a case study analysis of coatings and masonry partition walls cracks in a multifloor building in the São Paulo city, in Brazil. The methodology used for solving the problems considered: collecting data, diagnosis of the situation and solving procedure. It is believed, therefore, that the description of the diagnosis and the application of the methodological outline contribute to the wider dissemination of knowledge, pointing out alternatives to the resolution of the pathological problems.

**Keywords** Case study · Cracks · Masonry partition walls · Multifloor building · Concrete structures

## 1 Introduction

The changes that have occurred in the way of constructing in Brazil in recent years carry along advances, but also concerns. The technological development by the use of materials, particularly concrete, the slender structures and challenging work deadlines allow to observe pathological manifestations such as those presented in this paper, not infrequently reported in other studies.

The constructive process shown Fig. 1 has focused on the execution of higher and thinner buildings, large spans, fewer columns and slabs of reduced thickness, characteristics that have made the structures more deformable (Oliveira 2013).

---

A. Casado Lordsleem (✉)

Polytechnic School of Pernambuco University (POLI/UPPE), Recife, Brazil  
e-mail: acasado@poli.br

**Fig. 1** Brazilian regular building construction: in loco moulded concrete structure and brick masonry partition walls



In contrast, wall partition masonries suffer from the reduced capacity to absorb deformations, resulting from the increased rigidity with the advent of more resistant and larger hollowed blocks as well as by the connection with the structure.

The elements involving wall partition masonries are the most susceptible to cracks in the Brazilian regular building construction and, often, masonry wall recoveries are the most seen in these worksites, whether for aesthetic, psychological or performance aspects, as highlighted by Costa (2012), Oliveira (2013), Overseas Building Note (1993), Silva and Abrantes (2007) and Teixeira (2010).

Among all forms of pathological manifestations in buildings, cracks are the symptoms that usually draw more attention and cause more concern to users, as a result of the fear that the building will ruin.

The study of masonry cracks, the main technology used today in Brazilian vertical partition walls, from its characteristic manifestations and probable causes (Fig. 2), enable a deeper understanding of its formation mechanisms and its possible measures of therapy and prevention (Magalhães 2004).

From the standpoint of structural safety, the existing cracks in the masonry partition walls, usually with limited openings, are not a cause for major concern or alarm indication, as analyzed by Lichtenstein (1985) as they do not interfere on its stability.

Regarding performance, the fundamental question is how much the cracks interferes in the functional requirements of the masonry partition walls. From this

**Fig. 2** Cracks in masonry partition walls



point of view, many of the user requirements are compromised: impermeability; the hygrothermal comfort; the visual comfort; the acoustic comfort; the tactile comfort and durability, as analysed by Martins (2010), Oliveira et al. (2010) and Silva and Abrantes (2007).

It stands out that the passing cracks on the masonry facades constitute a path for the rain water penetration, promoting early deterioration of the building, besides the discomfort and health problems to its users.

In most cases, according to considerations made by Franco et al. (1994), “the cracks which are considered harmful are not the ones that relate to the stability of the masonry or to limit a fissuring state, but those that allow the water penetration through the joints or yet, the cracks that by its characteristics, bring along damage to the requirements arising from the demands of psychosocial users (mainly aesthetics and fear for safety)”.

However, in recent years, several cases of crushings and masonry cracks as well as coating detachment have been reported, among which those published in the reports by Costa (2012), Sahade et al. (2013), Silva (2004) and Tramontin et al. (2013), causing constant concern to users and professionals engaged in the building construction.

A few years ago, the problems were restricted to cracks that were virtually unnoticed, but in these last two decades have become crushing and masonry rupture and, in some more severe cases, total collapse of the partition walls, causing panic among users and losses to construction companies.

Within this context and considering the complexity of the subject, the practical case study seeks to contribute to the understanding of the crushing’s and fissuring

manifested in buildings by analyzing the causes and recommending possible recovery measures which will solve the problems, minimizing the probability of these pathologies recurrence.

## 2 Objective

This work presents a practical case study regarding the cracks pathological manifestations on the vertical masonry partition walls in a multiple floor flat residency-type building in São Paulo city in Brazil.

## 3 Methodology

The methodology adopted for the resolution of pathological problems identified in this case study was divided into 04 steps: subsidy inquiry, diagnosis of the situation, definition of the conduct and evaluation and records.

Figure 3, adapted from the work of Lichtenstein (1985), illustrates the sequence formulated to resolve these pathologies.

In step 1, which is subsidy inquiry, consisted in the collection and organization of the necessary and sufficient information for the complete understanding of the pathological phenomena. The information was obtained through an onsite

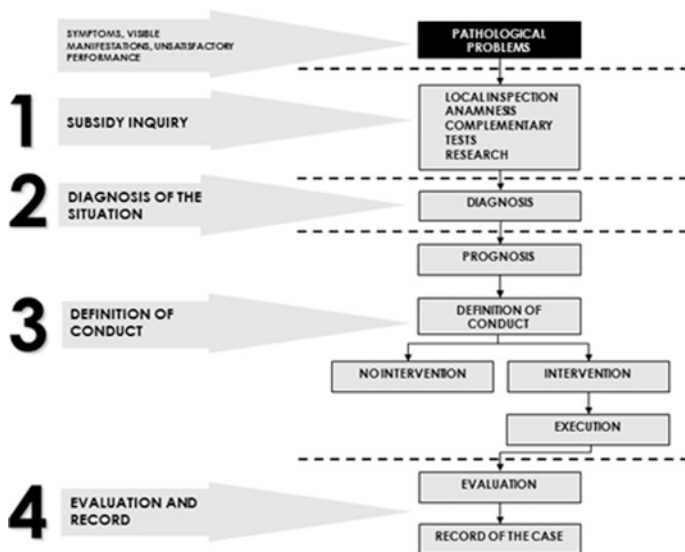


Fig. 3 Resolution of pathological problems: general structure adopted in the case study

inspection, from a survey of the building problems history and the result from visual observations.

Step 2 of situation diagnosis consisted in the understanding of the phenomena in terms of the cause and effect relations of the problems identified. It was sought to comprehend the “why” and “how” from the data collected in the previous step.

On step 3, definition of conduct, contemplated the establishment of hypotheses about the evolution of the problem (prognosis) and the prescription of the work to be done to solve the problems identified, considering the definition about the materials, labour and the equipment to be used.

Step 4, carried out with the development of this paper, consists on the activities of evaluation and record of the case, which allowed the verification of the recovery service on the performance restoration and the problem/solution formalization, respectively.

Following, the first 3 steps are described in detail for the practical case study considered in this paper, preserving the identification of names and brands.

## **4 Pathological Problems Resolution**

### **4.1 Subsidy Inquiry**

The pathological problems identified are associated to the inner coating cracking of masonry partition walls in the apartments and common public areas of the building (flat), located in the São Paulo city, São Paulo State in Brazil.

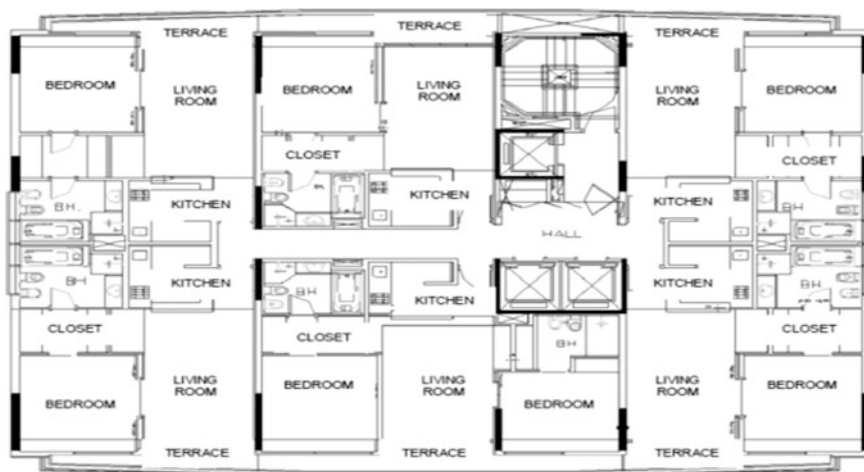
The problems analysis is the result of information obtained on technical visits to the flat, visual inspections, history discover of the services performed during the site work and the interviews with the craftsman, structure designer and flat manager; besides the study of architectural and structure designs.

The building was opened in March/2002 (delivery date of construction to the developer in December/2001) and consists of 03 basement levels, ground floor, mezzanine, 14 type floors, penthouse and engine room.

Each type floor have 06 apartments, consisting of room (living), kitchen, bedroom, closet and bathroom (BH). The arrangement scheme of the masonry partition walls and the pillars positioning can be seen in Fig. 4.

The constructive process used is characterized by the production of the structure in reinforced concrete with wooden formworks, moulded onsite (27.5 MPa from the 2nd to the 8th floor, 25 MPa from the 9th floor onwards) and vertical masonry partition walls with ceramic bricks and plasterboard.

According to the information provided by the craftsman taking part in this worksite, based on a questionnaire sent for data collection, it was possible to obtain some characteristics from the structure and masonry partition walls subsystems.



**Fig. 4** Partial scheme of the partition masonry walls and the pillars positioning

As to the production technology of the structure, it could be verified that the cure was performed with water spray for a period of 07 days and the permanence period of reshoring was of 25 days.

Regarding the production technology of masonry partition walls, the use of the same ceramic block for marking was reported as well as for elevation and on the last row of masonry, the mortar used in the blocks settling and fixation of the wall to the structure was one of the multiple use type. In the fixing mortar, an additive expander was attached.

The walls coating investigated is basically composed of mortar finished with plaster and latex paint (bedrooms and bathrooms) and textured mortar in the lobby (flat reception).

## **4.2** *Diagnosis of the Situation*

During the visits to the flat, accompanied by the administrative management of the property, it was possible to inspect basements, ground floor, mezzanine and 09 apartments (floors: 1st, 2nd, 11th, 13th and 14th).

Several configurations of cracks were observed as shown in Table 1, being grouped together by type according to the most suitable recovery (item 4.3).

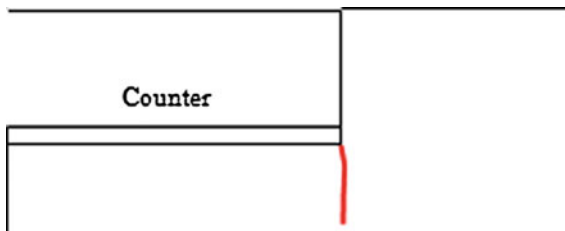
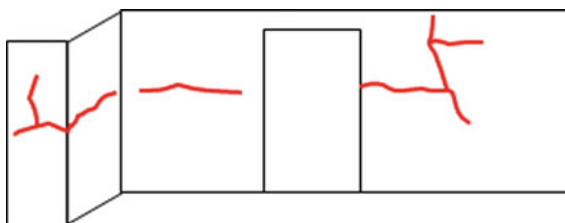
Figures 5, 6, 7, 8, 9, 10, 11 and 12 show the main graphical representations of the occurrence of cracks in the flat.

The cracks observed in the mortar coatings are pathological events that were originated in some cases, in the own mortar coating and in most cases, in the masonry partition walls.



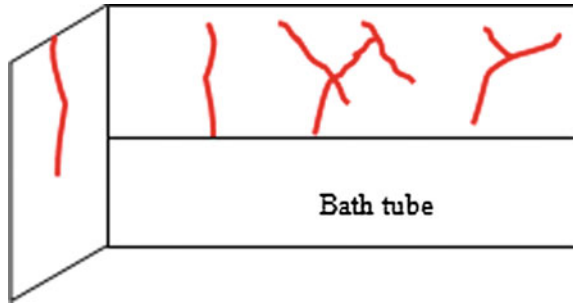
**Table 1** Pathologies by typology of proposed recovery

Pathologies description	Incidence	Type
Cracks and cracks on bathroom shafts	08 apartments	1
Cracks under the counter that separates kitchen/living	04 apartments	
Vertical crack between shaft/pillar of the elevator box	01 apartment	
Isolated crack on masonry walls with smooth coating		
Slanted cracks and cracks on superior, horizontal and vertical extremes on the center	Restaurant (mezzanine)	
Slanted cracks and cracks on right extreme	Conditioning room (mezzanine)	
Slanted cracks and cracks on left extreme	Business center (mezzanine)	
Slanted cracks and cracks on superior and horizontal extremes on top center	Division with empty space of restaurant (mezzanine)	
Cracks mapped on coatings above bath tubs	08 apartments	2
Vertical crack at the encounter between masonry/plasterboard walls	03 apartments	3
Vertical crack on the doors corner in plasterboard walls		
Slanted cracks and cracks	Entrance hall (ground)	4

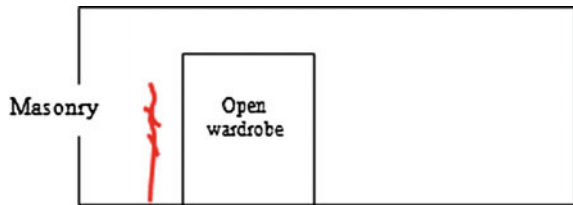
**Fig. 5** Division wall living/kitchen**Fig. 6** Wall of the bathroom door and wall on the left

The cracks verified in the bathroom shafts are manifested on the mortar coating and also on the masonry partition walls. It was possible to verify in this region (Fig. 13), that the mortar coating was 5 cm thick [contrary to standard specifications (Costa 2012)], being the wall supported on a very deformable slab.

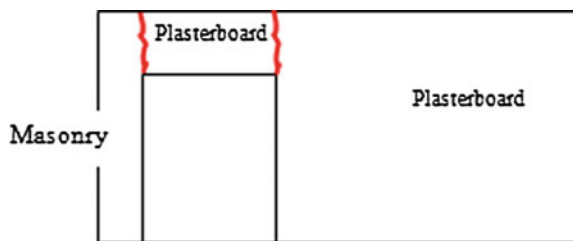
**Fig. 7** Wall above bath tub and wall on the left



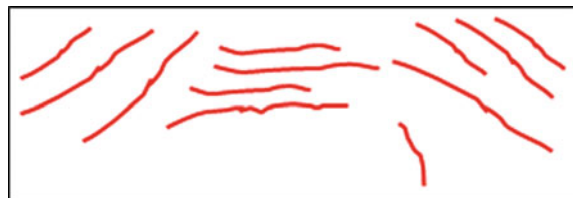
**Fig. 8** Division wall living/bedroom



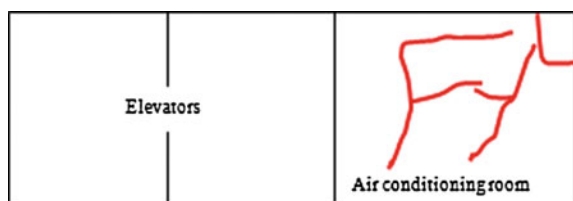
**Fig. 9** Division wall living/bedroom



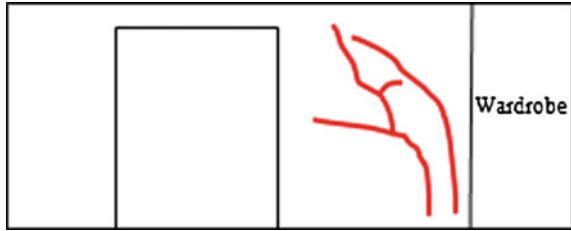
**Fig. 10** Restaurant (mezzanine)



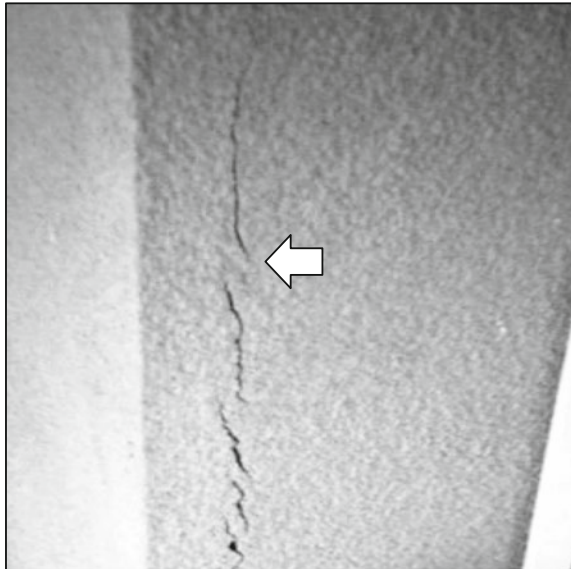
**Fig. 11** Wall of the air conditioning room (mezzanine)



**Fig. 12** Wall of the business center (mezzanine)



**Fig. 13** 5 cm thickness of mortar coating in the shaft bathroom



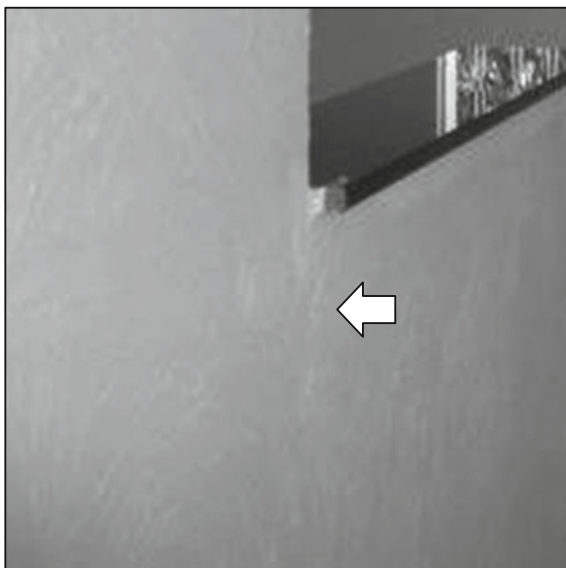
According to Franco et al. (1994), slabs with thickness inferior to  $C/60$  and beams under  $C/16$  high are considered highly deformable elements, where  $C$  is the length of the wall.

The cracks observed below the counter that separates the kitchen from the living room are isolated (Fig. 14), appearing on the mortar coating and also on the masonry partition wall.

The existence of openings on the walls is favorable for the appearance of cracks, as its vertices are regions of high stress concentration. The consequent needs from the deformation of concrete structures, being instantaneous or slow, from the deformations caused by thermal-hygroscopic variations from the masonry itself, overiding the resistance of the masonry materials were relieved in the cracks form.

The appearance of vertical cracks in shaft/pillar encounter of the elevator box may have been caused by the insufficient or inadequate anchorage between the walls that constitute the shaft and the pillars, in order to minimize the differential distortions between them.

**Fig. 14** Isolated crack below the counter between the living room/kitchen



Cracks with mapped configuration observed in coatings above the bath tubs were probably caused by the retraction of mortar. The humidity loss at early stages triggers retraction movements, which generate internal traction stresses and hence, the fissuring of the coating.

It was verified that in this region, the mortar coating had up to 7 cm of thickness, being the wall supported on a very deformable slab. When the removal of this part of the coating was performed in this region, it was possible to observe the existence of three mortar layers: being the first 5 cm thick; the intermediate of 1 cm and the surface, restricted to fissuring with 1 cm.

The vertical cracks observed in the encounter between masonry walls/plasterboard (see Fig. 15) may have been caused by differential deformations between these materials.

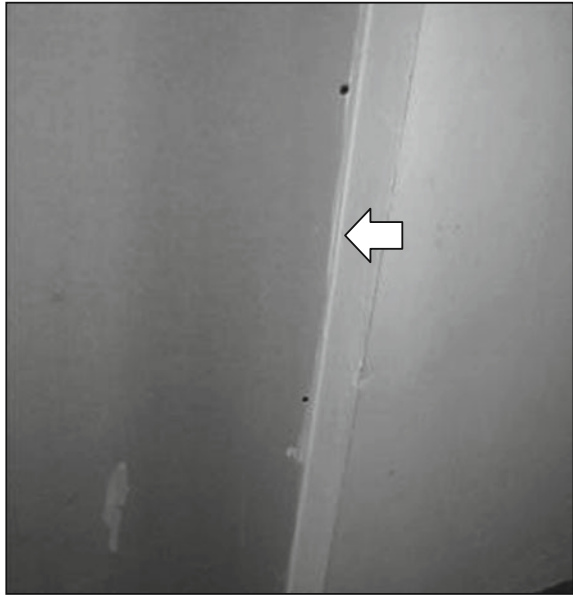
The vertical cracks observed on the corner of doors in walls of plasterboard (see Fig. 16) may have been occasioned by improper positioning of joints between plasterboard in these locations.

The cracks observed in the entrance hall and restaurant are pathological manifestations caused, probably, by the deformations of the surrounding concrete structure.

Particularly, the configuration of the cracks observed in the restaurant demonstrate the occurrence of differential deformations between structural elements of the upper part (slab) and bottom part (beam—new structural piece performed subsequently to the floor) of the wall (Lordsleem 1997).

The cracks observed on the mortar coatings of the mezzanine are pathological manifestations that are originated, in most cases, in the sealing masonry. The configuration of the passing cracks observed in the circulation area of the

**Fig. 15** The vertical crack between masonry wall/plasterboard



**Fig. 16** The vertical crack on the corner of doors in plasterboard walls (not original—just for example)



mezzanine, on the walls of the air conditioning business center rooms, are slanted and with analogous orientation, suggesting the occurrence of a more pronounced deformation on the opposite side of the elevator pillars, which are elements of high rigidity.

**Fig. 17** The masonry is unified to the structure with the upper fixation—expansive mortar (not original—just for example)



Additionally, in this region the wall is supported on a very deformable slab (10 cm thick).

The construction techniques used for the implementation of the walls may also have enhanced the undesired transmission of the reinforced concrete structures efforts for masonry partition wall.

From the moment in which the masonry is totally unified to the structure (Fig. 17), with the upper fixation (expansive mortar), the masonry/structure combination becomes monolithic and work together as a single element.

In the case of structures that allow a greater deformation, such as the one presented here, the use of the described technique for the execution of the walls produces a state of initial tension which will be elevated over time by the loads transmitted to the walls, increasing the possibility of pathologies development.

### **4.3 Solutions**

In the analysis performed, the walls cracks are demonstrated on the coatings with origin in the mortar coating as well as, specially, on the masonry partition wall.

Considering the diagnosis in the previous step, it is worth considering for the prognosis, the occurrence of the slow deformation of concrete, a phenomenon that occurs in all reinforced concrete structures, especially in first years of life.

According to Silva (2004), “in average, 25 % of the total fluency occurs in up to two weeks after the loading, 55 % in up to three months and 75 % up to a year”.

The existing cracks are spots where the walls are weakened, working as relief joint from the tensions with which they are subjected, such as deformation by cyclic temperature variation. These effects cause the cracks to become active, moving according to climatic variations.

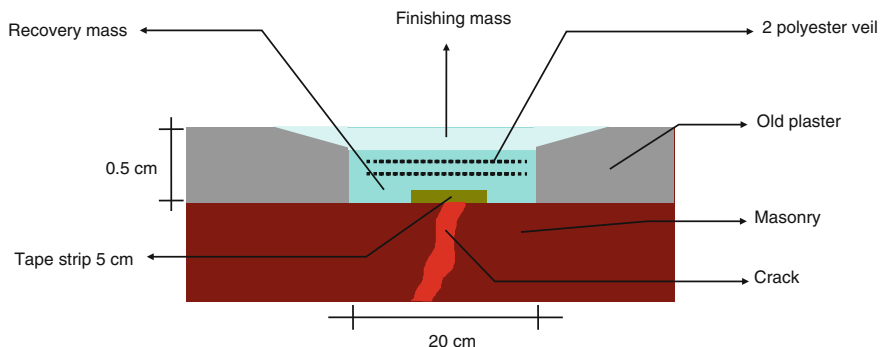
The selected recovery technique must take into account the cracks movimentation. Thus, the materials used for the recovery should allow movement, otherwise, if a rigid recovery is used, there is the possibility of a resurgence of the problem or the manifestation in new locations.

The proposed recoveries for the case study presented in this paper are briefly presented:

- recovery type 1: performance of the flexible recovery, according to specifications presented in the reports of Lordsleem (1997) and Lordsleem and Franco (1998);
- recovery type 2: the proposition is relative to the mortar coating executed in more than one layer, whose cracks were restricted to the surface layer of the coating, 1 cm thick. Proceed to the complete removal of the damaged mortar coating layer on which the cracks manifest. Run a new layer of additivated mortar with 0.22 L of acrylic resin for each 40 kg sack of conventional industrialized mortar coating. Perform the finishing using a mass specific for finishing formed by the mixture of acrylic resin and acrylic mass, with trace in volume: 0.5:1 (acrylic resin:acrylic mass), using a trowel and a steel spatula;
- recovery type 3: perform recovery type 1 without the need of using layers of polyester veils;
- recovery type 4: perform recovery type 1 and make the replacement of the existing coating (textured) for some other with smooth finishing, which would allow the proposed recovery.

Whereas the majority of recoveries is the type 1, it will be described in sequence. The preparation recovery activities are:

- protect the area before services start, such as: flooring, baseboard, bath and objects left near the recovery site;
- scratching a range of 20 cm width (leaving the crack in the middle) and over the end of the crack at least 30 cm, when possible;
- proceed to cut the damaged coating scratched range demarcated by the wall, removing the coating to a depth of 0.5 cm to the base or, if the coating thickness is less than this;
- in the event of depressions fill them with mortar;
- if the crack end in a transverse wall, or along the upper beam or lower slab, after the open end of the crack a range of 30 cm along the corner;
- clean the track with a brush to eliminate waste and dust;
- applying a primer coat of 20 cm along the track, with a mixture of PVA glue and water in a ratio of 1:3 (by volume). Wait drying for 2 h;
- if there is problem of adhesion between the recovery and the existing coating should extend the cut lining up to 1 cm and 0.5 cm complete with flexible



**Fig. 18** Overview of the recovery procedure

adhesive mortar or extend the cut to the masonry and redo the whole plaster. It should leave a recess of 0.5 cm for the implementation of recovery, as shown in Fig. 18. It is important to stress the coating in the crack region with a spatula, while still fresh. Wait for the time required for hardening.

The recovery activities are:

- clean the track prepared with a dry cloth to remove loose particles and dust;
- applying a polypropylene tape strip of 5 cm wide, being careful to leave no air bubble under the tape. 1 cm overlap on any amendment;
- preparing recovery mass, mixing vigorously to obtain a homogeneous mix without the formation of lumps. It is recommended to use electric drill equipped with a mixing shaft or mechanical mixer;
- recovery mass should be comprised of: water, PVA glue and PVA mas by volume: 1:4:3, respectively;
- passing over the entire length of the strip a thin layer of the recovery mass;
- cutting the polyester veil 14 cm-wide strips;
- immerse the first strip in a container containing the recovery mass, making sure that all the veil is moistened. Before applying, remove all excess mass;
- initiate the application of veils from top to bottom;
- use a minimum of 5 cm run through an amendment of the veils. Care should be taken so that the thickness of this amendment does not exceed the depth of the clean range by simply withdraw the entire mass over the place;
- the surface of the already laid veil should be moistened with the mass recovery, using a brush and a trowel;
- must be put second veil dry strip (without diving into the recovery mass);
- passes over a layer of recovery mass over veil laid, using a brush and trowel;
- carry out cleaning of excess mass that ran down the wall while not yet hardened.



The polyester veil serves to structure the recovery, minimizing the possibility of cracking. Even if some microcracks occur, enhanced with the veil should prevent its opening and make them imperceptible to the naked eye. The recovery mass formed by mixing water, PVA mass with PVA resin glue has more favourable characteristics give the accommodation efforts.

The finishing activities are:

- immediately after placing the second veil strips should proceed recovery coating with the finishing mass formed by mixing: PVA glue and PVA mass, with a stroke volume: 1:1 using a steel spatula and trowel;
- carry out excess cleaning finishing mass that ran down the wall while still not hardened;
- waiting time needed for the finishing mass acquire resistance that allows the adjustment of the surface for sanding and scraping (spatula);
- after the surface adjustment, apply new finishing mass layer (stroke volume: 1:1). If necessary to apply more coats of finishing mass, they shall be applied and sanded to ensure a perfect finish;
- carrying wall paint with PVA-based ink, as specified in the previous finish.

It is worth pointing out that the proposed recovery procedures were developed for the recovery from the effects of the processes that cause fissuring, without however, eradicating its causes, with the specific purpose of repairing cracks in masonry partition walls and coatings.

## 5 Conclusions

In this paper, a practical case study was presented where it was sought to investigate the possible causes that originate cracks and cracks in vertical partition walls in a flat type building with multiple floors.

Characteristic elements of the current context of building construction, potential influencers of pathologies were verified in the subsidy inquiry, from which the large amount of vertical sealings on slabs stood out, the incidence of broader spaces between pillars, the rigid attachment of the masonry to the beam/top slab, the absence of reinforcement in the encounter masonry/plasterboard and the over-thickness of the mortar coating.

From the analysis of the collected data, it was possible to establish the diagnosis of the situation, in which prevailed as the main cause of fissuring of vertical sealing, the deformability of the concrete structure, whose solidarization with the walls produced a greater state of tension than the capacity of masonry resistance.

In view of what was exposed, it is expected that the understanding of the problem, conducted in a systematic way, can lead to the knowledge domain and contribute to alert users and the technical community about the existing limitations, conducting researches on the subject that respond effectively to the admissible deformations in the elements in the present.

## References

- Costa A (2012) Building inspection: A case study of a residence building, Civil engineering monograph. Extremo Sul Catarinense University, Criciúma
- Franco L, Barros M, Sabbatini F (1994) Development of a construction method masonry partition wall of autoclaved cellular concrete blocks. In: Report CPqDCC n. 20081, São Paulo
- Lichtenstein N (1985) Constructions pathologies: procedure for formulation of fault diagnosis and determining the appropriate buildings solutions, Master Dissertation, São Paulo University, São Paulo
- Lordsleem A Jr (1997) Cracks recovery systems masonry wall partition: deformability evaluation, Master Dissertation, São Paulo University, São Paulo
- Lordsleem A Jr, Franco L (1998) Cracks facade recovery system evaluation. In: Proc. 7th Encontro Nacional de Tecnologia do Ambiente Construído vol 2, pp 581–590
- Magalhães E (2004) Masonry cracks: typical configurations and effects on the Rio Grande do Sul state, Master Dissertation, Federal do Rio Grande do Sul University, Porto Alegre
- Martins J (2010) Pathology in brick masonry walls, Master Dissertation, Instituto Superior Técnico, Lisboa
- Oliveira D (2013) Survey of pathology causes in construction, Civil engineering monograph. Rio de Janeiro Federal University, Rio de Janeiro
- Oliveira E, Silva R, Lourenço P (2010) Experimental analysis of masonry walls reinforced with steel joint. *Construindo* 2:7–13
- Overseas Building Note (1993) Maintenance of low-cost buildings. Liverpool, Garston
- Sahade R, Machado L, Cavani G (2013) Cracks recovery systems evaluation of partition walls coatings. In: Proc. 10th Simpósio Brasileiro de Tecnologia das Argamassas, vol 1, pp1–10
- Silva M (2004) São Paulo: Seminário de estruturas, 2004. Presents considerations on the deformation performance of structures. Available [http://www.sindusconsp.com.br/temp/Seminário\\_de\\_estruturas/deformacoes.htm](http://www.sindusconsp.com.br/temp/Seminário_de_estruturas/deformacoes.htm). Cited 23 Abr 2004
- Silva J, Abrantes V (2007) Pathology in masonry walls: causes and solutions. In: Proc. 1st Seminário sobre Paredes de Alvenaria, vol 1, pp 65–84
- Teixeira C (2010) Masonry wall partition cracks interface with reinforced concrete structures: recommendations for prevention techniques, Civil engineering monograph. Rio Grande do Sul Federal University, Porto Alegre
- Tramontin A, Moreno A Jr, Oliveira C (2013) Experimental evaluation of cracks prevention methods in masonry wall partition interface and concrete pillar. *Ibracon Struct Mater J* 6: 765–782

# Diagnosis and Seismic Analysis of the Our Lady of Conception Church, Portugal

Nuno Mendes, Paulo B. Lourenço, Marianna Besca,  
Elisabetta Trufelli and Alberto Barontini

**Abstract** The Our Lady of Conception church, located in village of Monforte (Portugal), is classified as a Public Interest Building and is not in use nowadays. The church is constituted by the nave, the chancel, the sacristy, and the corridor to access the pulpit. The total longitudinal and transversal dimensions of the church are equal to 21.10 and 12.50 m, respectively. The structure presents masonry walls with different thickness, buttresses, and barrel vaults. Due to an intervention carried out in the past, the church presents also ring beams at the top of the walls and concrete slabs. The structure presents severe damage, and a study was performed. The study involved the damage survey, dynamic identification tests, and the structural analysis. The damage survey showed that, in general, the masonry walls are in good conditions, with exception of the transversal walls of the nave, which present severe cracks. The ribs of the vault of the nave present also severe cracks. As consequence, the infiltrations of the rainwaters have increased the degradation of the vault and paintings. Furthermore, the external floor presents settlements in the southwest direction. The dynamic identification test was carried out under the action of ambient excitation and allowed to estimate the dynamic properties of the church, namely frequencies, mode shapes, and damping ratios. A numerical model was prepared and calibrated, based on the first four experimental modes estimated

---

N. Mendes (✉) · P.B. Lourenço  
ISISE—Institute for Sustainability and Innovation in Structural Engineering,  
University of Minho, 4800-058 Guimarães, Portugal  
e-mail: nunomendes@civil.uminho.pt

P.B. Lourenço  
e-mail: pbl@civil.uminho.pt

M. Besca · E. Trufelli  
Università degli Studi di Perugia, Piazza Università 1, 06123 Perugia, Italy  
e-mail: marianna.besca@hotmail.it

E. Trufelli  
e-mail: eli3tr@gmail.com

A. Barontini  
University of Minho, 4800-058 Guimarães, Portugal  
e-mail: alberto.barontini@stud.unifi.it

in the dynamic identification tests. The average error between the experimental and numerical frequencies of the first four modes is equal to 4 %. The results of the seismic analysis showed that the transversal direction of the church is the most vulnerable direction, in which the load factor is equal to 0.35. In the pushover analysis in the transversal direction, the transversal walls present diagonal cracks and the vault of the nave presents severe damage. In the pushover analysis in the longitudinal direction, the collapse of the church corresponds to the out-of-plane collapse of the main façade (load factor equal to 0.65).

**Keywords** Masonry · Existing buildings · Earthquakes · Seismic performance

## 1 Introduction

The seismic performance of historical masonry buildings is a complex task. The material properties, the construction techniques, which swiftly moved from the traditional practice, the geometry of the structure (lack of in-plane and in-elevation regularity), and the developments on the methods of analysis are the main aspects involved in the study of seismic performance of historical masonry buildings. The consideration of these aspects requires qualified engineers with advanced knowledge on the area.

Several structural analysis techniques can be adopted for the assessment of the seismic performance of masonry structure, such as limit analysis, including the static and kinematic approaches, pushover analysis, and nonlinear dynamic analysis with time integration. Furthermore, three main modeling approaches can be adopted for masonry (Lourenço 1996) as follows: (a) detailed micro-modelling, in which the units and mortar of joints are represented by continuum elements, whereas the unit/mortar interface is represented by discontinuous elements; (b) simplified micro-modeling, in which the expanded units are represented by continuum elements, whereas the behavior of the mortar joints and unit/mortar interface is lumped in discontinuous elements; and (c) macro-modeling, in which units, mortar, and the unit/mortar interface are smeared out as a homogeneous continuum material. Finally, two main methods for advanced numerical modeling can be used as follows: (a) finite element method (FEM) and (b) discrete element method (DEM).

Besides the challenge on the seismic assessment, the evaluation of strengthening techniques for the reduction of the seismic vulnerability of the historical constructions, preserving the historical and architectural aspects, is also complex. Thus, the intervention works should be carried out after a careful diagnosis and evaluation of the safety of the structure in its present state, as also set in the Recommendations for the Analysis, Conservation and Structural Restoration of Architectural Heritage (ICOMOS) (ICOMOS 2005). These recommendations are intended to be useful to all those involved in conservation and restoration problems and not exclusively to the wide community of engineers (see Sect. 2).

This chapter presents a study on seismic performance of the Our Lady of Conception Church (Portugal). The church is not in use nowadays and presents significant structural damage either in masonry walls or in the vaults. Furthermore, the church presents other types of damage such as damp paths at the ceilings and at the base of masonry walls, detachment of the external plaster, and cracks on the external floor. First, the damage survey and the identification of the dynamic properties (frequencies, mode shapes, and damping ratios) of the church were carried out. Then, a numerical model of the church was prepared and calibrated, based on the dynamic properties estimated from the dynamic identification tests. Finally, the assessment of the seismic performance of the church was carried out based on the pushover with horizontal load distribution proportional to the mass of the structure.

## 2 ICOMOS Recommendations

The International Scientific Committee for the Analysis and Restoration of Structures of Architectural Heritage (ISCARSAH) has prepared recommendations (ICOMOS 2005), intended to be useful to all those involved in conservation and restoration problems. These recommendations contain Principles, where the basic concepts of conservation are presented, and Guidelines, where the rules and methodology that a designer should follow, are discussed. More comprehensive information on techniques and specific knowledge can be found elsewhere. In addition, normative and pre-normative guidelines are gradually becoming available, at least with respect to seismic rehabilitation, which is a major concern.

### 2.1 Principles

A multidisciplinary approach is required in any restoration project, and the peculiarity of heritage structures, with their complex history, requires the organization of studies and analysis in steps that are similar to those used in medicine. Anamnesis, diagnosis, therapy and controls, correspond respectively to the damage survey and search for significant information on the structure, evaluation of the causes of damage and decay, choice of the remedial measures and control of the efficiency of the interventions. Thus, no action should be undertaken without ascertaining the likely benefit and harm to the architectural heritage.

A full understanding of the structural behavior and material characteristics is essential for any project related to architectural heritage. Diagnosis and safety are based on historical information and qualitative and quantitative approaches. The qualitative approach is based on direct observation of the structural damage and material decay as well as historical and archaeological research, while the quantitative approach requires material and structural tests, monitoring, and structural

analysis. Often, the application of the same safety levels used in the design of new buildings requires excessive, if not impossible, measures. In these cases, other methods, appropriately justified, may allow different approaches to safety.

Therapy should address root causes rather than symptoms. Each intervention should be in proportion to the safety objectives, keeping intervention to the minimum necessary to guarantee safety and durability and with the least damage to heritage values. The choice between “traditional” and “innovative” techniques should be determined on a case-by-case basis with preference given to those that are least invasive and most compatible with heritage values, consistent with the need for safety and durability. At times, the difficulty of evaluating both the safety levels and the possible benefits of interventions may suggest “an observational method,” i.e., an incremental approach, beginning with a minimum level of intervention, with the possible adoption of subsequent supplementary or corrective measures.

The characteristics of materials used in restoration work (in particular, new materials) and their compatibility with existing materials should be fully established. This must include long-term effects, so that undesirable side effects are avoided.

Finally, a most relevant aspect is that the value and authenticity of architectural heritage cannot be assessed by fixed criteria because of the diversity of cultural backgrounds and acceptable practices.

## 2.2 *Guidelines*

A combination of both scientific and cultural knowledge and experience is indispensable for the study of all architectural heritage. The purpose of all studies, research, and interventions is to safeguard the cultural and historical value of the building as a whole, and structural engineering is the scientific support necessary to obtain this result. The evaluation of a building frequently requires a holistic approach considering the building as a whole, rather than just the assessment of individual elements.

The investigation of the structure requires an interdisciplinary approach that goes beyond simple technical considerations, because historical research can discover phenomena involving structural issues, while historical questions may be answered from the process of understanding the structural behavior. Knowledge of the structure requires information on its conception, on its constructional techniques, on the processes of decay and damage, on changes that have been made, and finally on its present state.

The recommended methodology for completing a project is shown in Fig. 1, where an iterative process is clearly required, between the tasks of data acquisition, structural behavior, and diagnosis and safety. In particular, diagnosis evaluation and safety evaluation of the structure are two consecutive and related stages on the basis of which the effective need for and extent of treatment measures is determined. If these stages are performed incorrectly, the resulting decisions will be arbitrary: Poor

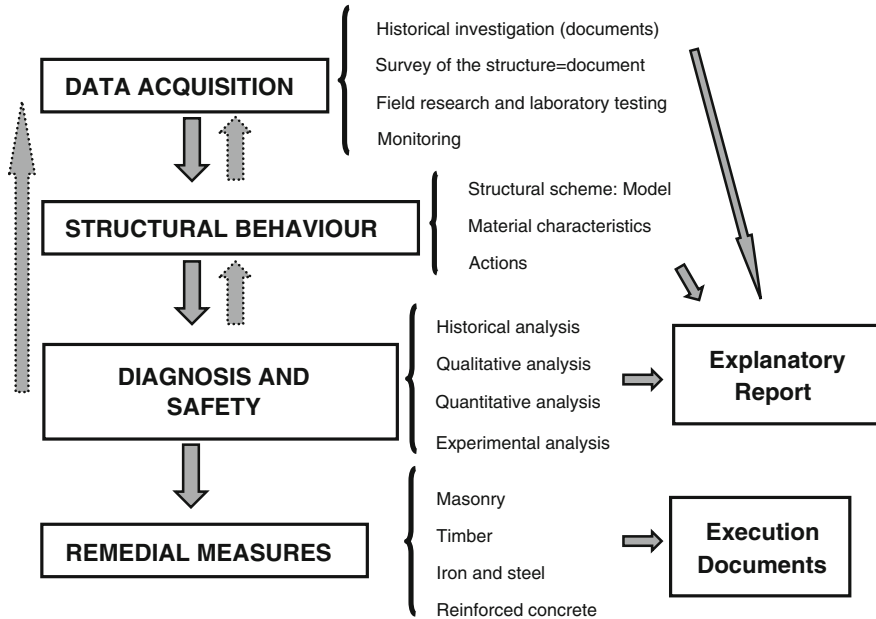


Fig. 1 Flowchart with methodology for structural interventions (ICOMOS 2005)

judgment may result in either conservative and therefore heavy-handed conservation measures or inadequate safety levels. Evaluation of the safety of the building should be based on both qualitative (as documentation, observation, etc.) and quantitative (as experimental, mathematical, etc.) methods that take into account the effect of the phenomena on structural behavior. Any assessment of safety is seriously affected by the uncertainty attached to data (actions, resistance, deformations, etc.), laws, models, assumptions, etc., used in the research and by the difficulty of representing real phenomena in a precise way.

### 3 Our Lady of Conception Church

#### 3.1 Review of the History and Description

The Our Lady of Conception church is located in the village of Monforte (Portalegre, Portugal) at 600 m from the downtown and outside the ancient medieval walls of the village, which previously protected the village of Monforte. This church is part of the complex of three churches (Calvary church and the St. John the Baptist church), which corresponds to the magical-religious triangle of the village of Monforte (Fig. 2). The churches were metrically positioned in correspondence



**Fig. 2** Religious triangle of the village of Monforte

with the vertices of a triangle. The triangle is a geometrical shape used in the mystical and religious traditions, through which the central mystery of Christian is represented—The Trinity. Furthermore, the triangle together with the number three is the symbol of the highest wisdom and of the perfect harmony and represents the spiritual perfection and the Supreme Being.

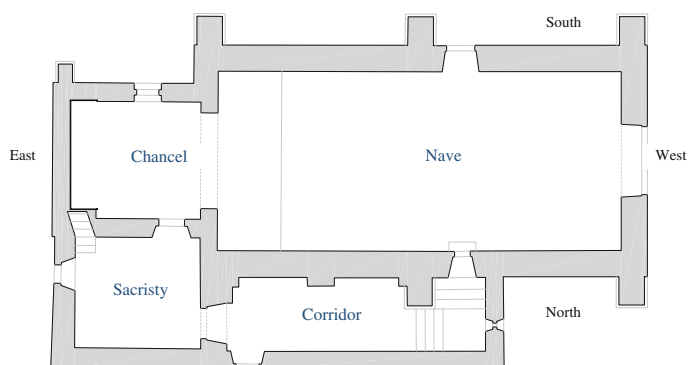
Although currently it is not known the exact construction date of the churches, taking into account the documents present in the Municipal Archive of the Council of Elvas, the Our Lady of Conception church was the first one to be built in the seventeenth century, followed by the church of St. John the Baptist (eighteenth century) and finally the Calvary church (eighteenth century or beginning of nineteenth century). However, this chronology is not totally in agreement with the documents of eighteenth century, namely the National Inquiry carried out after the Lisbon earthquake of 1755, in which it is verified that the Calvary church already existed with the current configuration (Silva 2000). In the absence of historical evidence that allows to accurately date the construction of the churches, the following chronology can be assumed: (a) Our Lady of Conception church: seventeenth century; (b) St. John the Baptist church: eighteenth century; and (c) Calvary church: end of eighteenth century.

The Our Lady of Conception church presents features that allow to identify it as a church of Manuelino–Mudejar style (Fig. 3) and is composed of the nave, the chancel, the sacristy, and the corridor for accessing the pulpit (Fig. 4). The masonry





**Fig. 3** Our Lady of Conception Church: **a** northwest view; **b** southeast view; **c** northeast view; **d** interior view



**Fig. 4** Plan of the Our Lady of Conception church

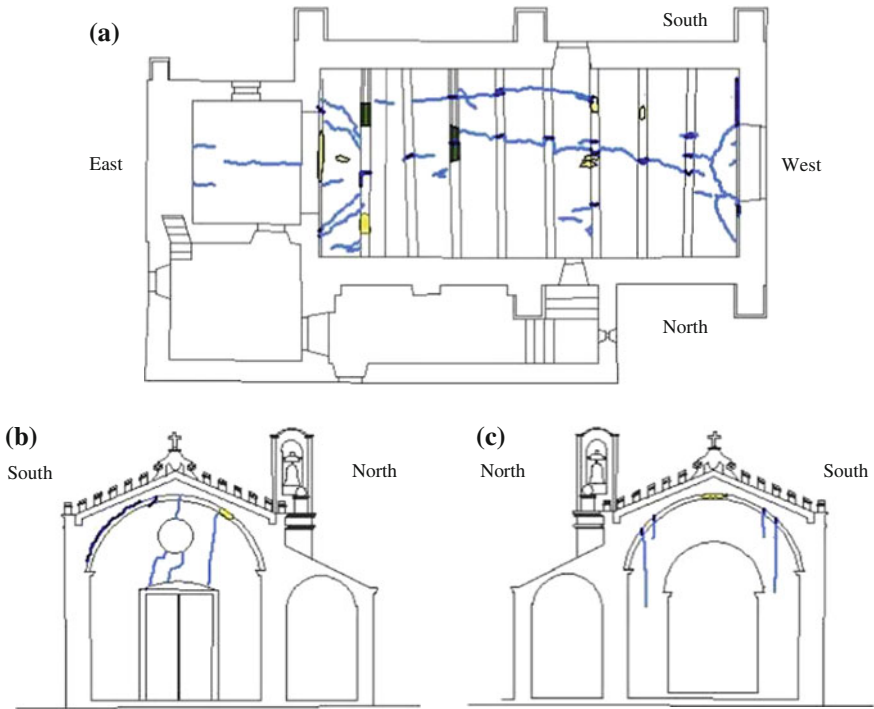
walls of the church present different thicknesses, namely 0.65 m in the chancel, 0.70 m in the sacristy, 0.92 in the central nave, and 0.65 m in the corridor. The masonry walls present eight buttresses with different geometry. The thickness of the buttresses ranges from 0.50 m (top of the sacristy) to 1.10 m (base of the nave). The total longitudinal and transversal dimensions of the church are equal to 21.10 and 12.50 m, respectively. The nave has 14.26 and 6.33 m in the longitudinal direction and transversal direction, respectively. The chancel has 4.43 and 3.87 m in the longitudinal direction and transversal direction, respectively. The corridor has 9.00 m in the longitudinal direction and 2.60 m in transversal direction. The maximum external height of the church is equal to 10.3 m. The nave presents a barrel vault with eight ribs. In general, the church presents gable roofs, with exception of the corridor (shed roof). Furthermore, the church presents ring beams at the top of the walls and concrete slabs with prestressed joists and hollow units (see Sect. 3.2).

### 3.2 *Conservation Works*

Several interventions of restoration and conservation on the Our Lady of Conception church were carried out. The interventions can be divided into two groups chronologically spaced in about 130 years: (a) interventions carried out between 1775 and 1840 and (b) interventions carried out in 1973. In the first period, and due to the infiltrations of rainwater, minor repairs and replacements of tiles at the roof were carried out. These works were performed using traditional materials from that time. Furthermore, some paintings were repainted, and some carpentry works were also carried out. For more details about these interventions, see Monforte Municipal Council (1774–1853). In the second group of interventions (1973), the rebuilt of the roofing of the church was performed by Directorate General for National Buildings and Monuments (DGEMN, Portugal). According to DGMEN (1973), the following works were carried out: (a) removal of roof in ruin and its structure; (b) demolition of some masonry elements of the roof; (c) construction of reinforced concrete ring beams at top of the masonry walls; (d) construction of the concrete slabs with prestressed joists and hollow units, including the insulation with an asphaltic product; (e) reconstruction and repair of battlements and pinnacles; (f) repair of the gargoyles; and (g) lime washing. The works at the roof were carried out using modern materials and not compatible to the original materials, leading to the conclusion that this intervention was harmful for the conservation of the paintings. Besides these two main interventions, small repairing works with mortar were carried out in the past, mainly at the barrel vault and roof of the corridor.

### 4 Damage Survey

The church presents a crack pattern with significant damage (Fig. 5), namely at the intrados of the barrel vault of the nave and at the transversal masonry walls of the nave (façade and chancel arch). The ribs of the vault present severe cracks along the longitudinal direction of the nave, mainly near to the central alignment and south masonry wall (Figs. 5 and 6). The cracks on the main façade present low/moderate



**Fig. 5** Crack pattern (interior view): **a** barrer vault of the chancel and nave; **b** main façade; **c** chancel arch

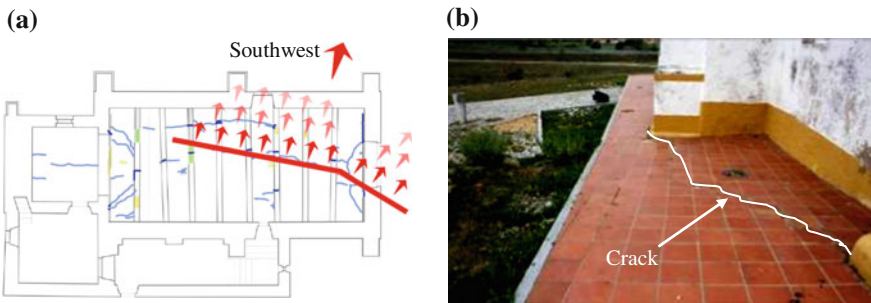


**Fig. 6** Cracks at the barrel vault of the nave

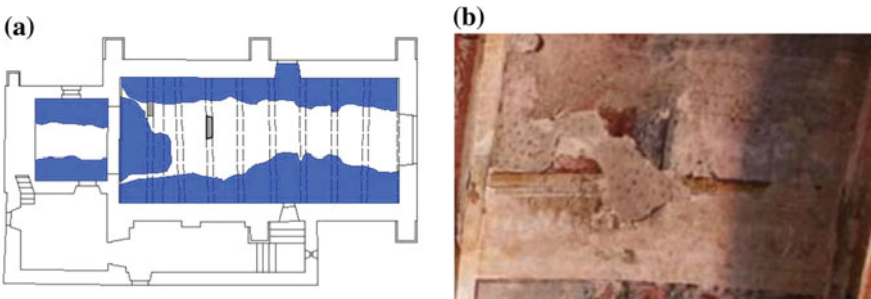
severity and concentrate at middle of the wall near the openings. However, the connection between the vault of nave and the main façade presents also a crack at the southwest corner (Fig. 5b). The arch of the chancel presents vertical cracks with low/moderate severity. These cracks concentrate at the top of the arch and near the corners (Fig. 5c).

The external floor of the church presents cracks associated to settlements of the soil in the southwest direction (Fig. 7). This type damage suggests that probably the settlements of the foundation soil of the church can also have occurred, which can be associated to the damage on the vaults and walls.

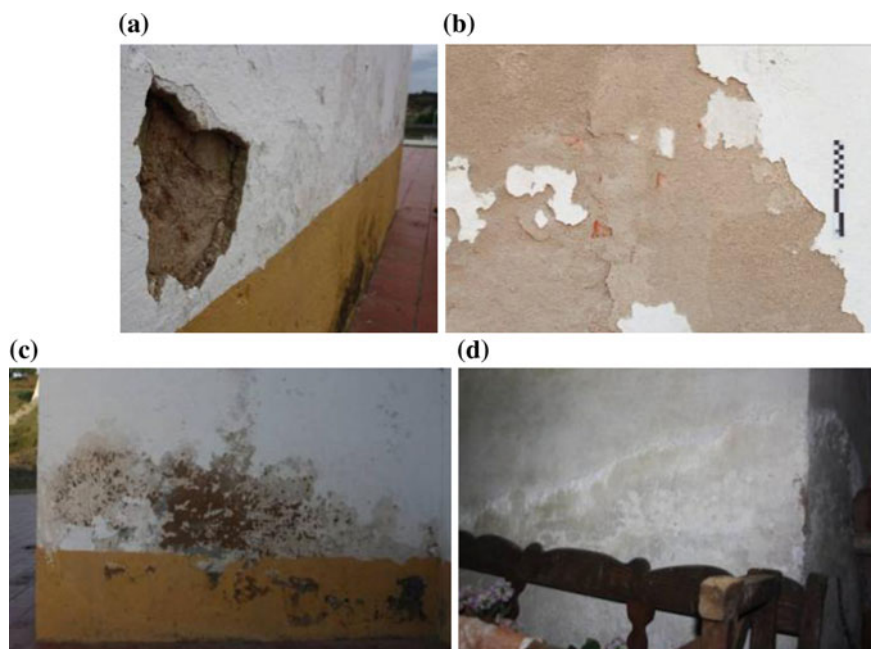
Besides the structural damage, the vaults and the masonry walls present other types of damage, such as damp patches. The damp patches on the vaults (Fig. 8) were caused by infiltrations of rainwater from the roof and concentrate near the connection with the masonry walls (infill material). Over time, the infiltrations have increased the degradation of the vault masonry and paintings. The masonry walls present detachment of the plaster at the external surface, deterioration of the plaster and paint, and rising damp at the base (Fig. 9). The roof presents vegetation, mainly



**Fig. 7** Deformation of the external floor: **a** direction of the deformation; **b** detail of the crack on the external floor



**Fig. 8** Damp patches: **a** barrel vaults of the chancel and nave; **b** detail of the deterioration of the paintings at the ceilings of the nave



**Fig. 9** Damage on the walls: **a** plaster detachment; **b** deterioration of the plaster and paint; **c** rising damp at the external surface; **d** rising damp at the interior surface

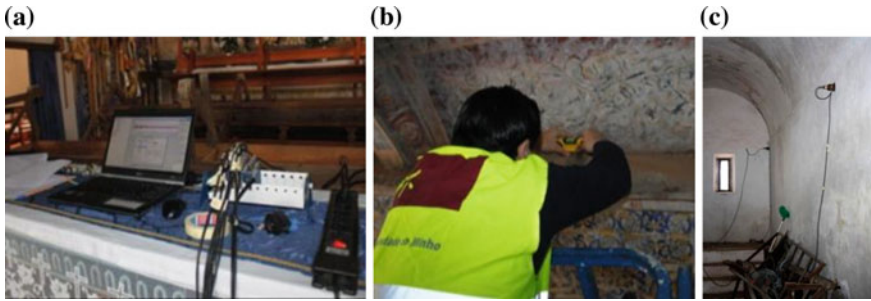
in the north side, and broken tiles. Furthermore, minor damages were also observed in the non-structural elements.

## 5 Dynamic Identification Tests

Dynamic identifications tests were carried out, aiming at estimating the dynamic properties (frequencies, mode shapes, and damping ratios) and updating a numerical model of the church.

The instrumentation required to conduct the dynamic identification tests consists of 12 accelerometers (10 V/g, frequency range from 0.15 to 1000 Hz, dynamic range  $\pm 0.5$  g), coaxial cables, and one 24-bit data acquisition system with software developed by University of Minho (Fig. 10). In order to improve the quality of signals, sensors were installed on wooden bases bonded to the measurement points (Fig. 10b). The structure was studied under the action of ambient excitations, i.e., natural vibrations to which the structure is normally subjected (wind or traffic).

The accelerometers were placed at the points of the structure characterized by higher modal displacements, which have been previously identified through a preliminary numerical model of the church. Based on observations obtained with



**Fig. 10** Dynamic identification tests: **a** acquisition system; **b** positioning of the wooden base of one of the points of measurement; **c** accelerometers fixed inside of the church

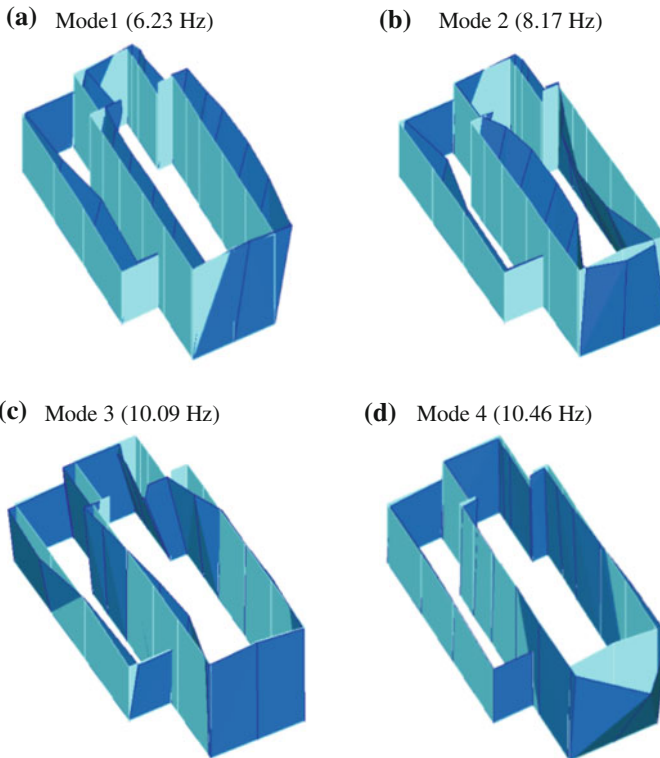
this model, the dynamic test was prepared according to three different configuration setups, where only horizontal accelerations were recorded. In the first setup, seven accelerometers were used, while in the second and third twelve accelerometers were used. In each setup, a different sensor arrangement was defined, except for the first two sensors, which were positioned as reference points. In this way, all the signals record in different points at different times can be correlated, making possible to estimate the modal displacements in a higher number of points compared to the number of available sensors. The accelerometers were placed all over the structure as follows: (a) in the nave at a 5 m high from the base of the wall; (b) in the sacristy at about 3 m high; (c) in the chancel at 3.8 m high; and (d) in the corridor at about 2 m high. The reference accelerometers were positioned at the centerline of the main façade in the longitudinal direction and in the lateral longitudinal wall in the transversal direction. In each setup, 10 min of ambient vibration was record at 200 Hz sampling rate.

To process the acquired data, the stochastic subspace identification/principal component (SSI-PC) method (Douglas and Reid 1982) was adopted. This method deals directly with time series (SSI-DATA, driven stochastic subspace identification), and it was used to estimate the modal parameters with high resolution. Table 1 presents the results of the dynamic identification tests, namely the natural frequencies and the damping ratios. Figure 11 presents the first four mode shapes.

As can be observed in Table 1, eight natural frequencies were estimated, ranging from 6.23 Hz up to 14.00 Hz. The coefficient of variations (COV) for the three measuring setups is lower than 2 %, indicating a good quality of the frequency estimates. In terms of damping ratios, an average value equal to 2.5 % was obtained but with an average COV equal to 26 %. The higher range for COVs indicates that damping was estimated with more difficulty, and therefore, its values have to be carefully take into account for further analysis. Concerning the mode shapes (Fig. 11), the first mode corresponds to the first global transversal mode of the church (6.23 Hz). The second mode corresponds mainly to a mode of the longitudinal walls in the out-of-plane direction (8.17 Hz), with the longitudinal walls of the nave in opposite phase. The third mode (10.09 Hz) corresponds to the second

**Table 1** Results of the dynamic identification tests by the SSI-PC method

	f (Hz)	$\sigma_f$ (Hz)	COV (%)	$\xi$ (%)	$\sigma_\xi$ (%)	COV (%)
Mode 1	6.23	0.04	0.71	1.85	0.36	19.46
Mode 2	8.17	0.03	0.42	1.72	0.20	11.63
Mode 3	10.09	0.10	0.96	2.21	0.77	34.84
Mode 4	10.46	0.24	2.29	2.52	1.44	57.14
Mode 5	11.62	0.08	0.68	2.73	0.43	15.75
Mode 6	12.84	0.10	0.78	1.64	0.48	29.27
Mode 7	13.69	0.18	1.31	3.91	0.11	2.81
Mode 8	14.00	0.12	0.86	2.90	1.02	35.17



**Fig. 11** Experimental mode shapes for the first four modes

global mode of the church with second curvature. The fourth mode activates the main façade in the longitudinal direction (local mode). As expected, the first modes mobilize the masonry walls in the direction of their lower stiffness (out-of-plane). The buttresses and the low height of the structure contributed to the high value for the first natural frequency.

## 6 Preparation and Calibration of the Numerical Model

A numerical model of the church (Fig. 12) was prepared based on the FEM in the advanced structural analysis software DIANA (TNO 2015), in which shell elements with quadratic interpolation were used for simulating the masonry walls, vaults, and concrete slabs. The ring beams were simulating using beam elements based on the theories of Mindlin (1995) and Reissner (1945). The translation degrees of freedom at the base were restrained. The numerical model has 3047 elements (161 beam elements and 2886 shell elements) with 8543 nodes, resulting in about 42,715 degrees of freedom.

The numerical model was calibrated with respect to the dynamic properties estimated through the dynamic identification tests. The Douglas and Reid method was adopted, in which the seven variables to calibrate were defined, namely the Young’s modulus of the transversal walls of the nave, Young’s modulus of the longitudinal walls of the nave, Young’s modulus of the walls of the chancel, Young’s modulus of the walls of the corridor and sacristy, Young’s modulus of the buttresses, Young’s modulus of the vaults, and Young’s modulus of the concrete elements. The density is equal to 1800, 1500, and 2500 kg/m<sup>3</sup> for masonry elements, slabs, and ring beams, respectively. A Poisson’s ratio equal to 0.2 was assumed for all materials.

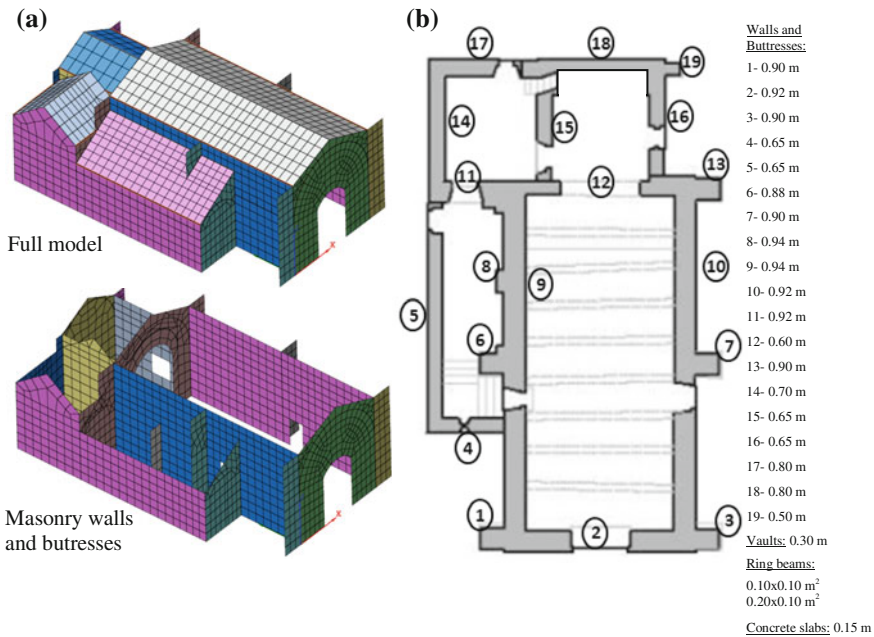
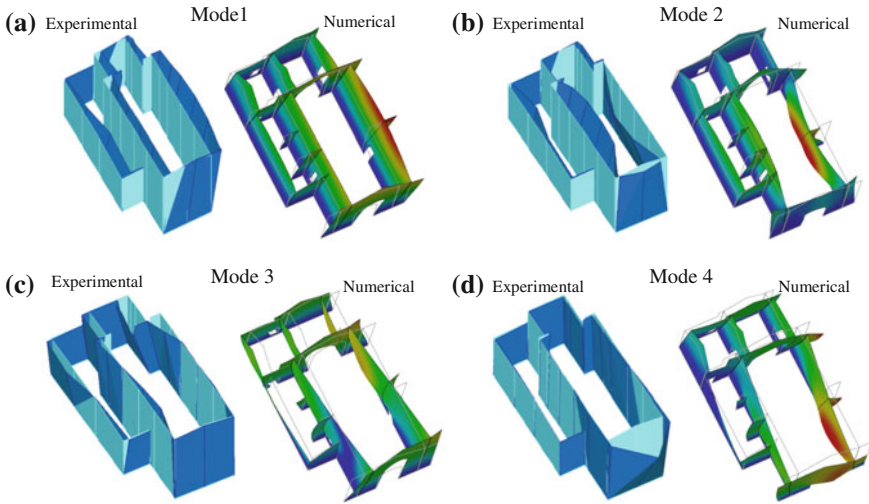


Fig. 12 Numerical model: a general views; b identification of the walls and buttresses and geometric properties





**Fig. 13** Numerical mode shapes for the first four modes

**Table 2** Experimental and numerical frequencies of the first four modes

	Experimental frequencies (Hz)	Numerical frequencies (Hz)	Error (%)
Mode 1	6.23	6.15	1.3
Mode 2	8.17	8.54	-4.5
Mode 3	10.09	9.72	3.7
Mode 4	10.46	9.92	5.2

The frequencies of the first four modes were calibrated, and average error of about 4 % was obtained (Table 2). The numerical mode shapes are presented in Fig. 13. The calibrated Young’s modulus is presented in Table 3.

The nonlinear behavior was assumed only for the masonry elements, namely walls, buttresses, and vaults. The selection of the masonry constitutive model was based on a compromise between accuracy of the results and computation time. The Total Strain Rotate Crack Model (TNO 2015) assumes smeared cracks based on total strains and was selected due to its robustness and simplicity. The nonlinear behavior of the masonry was considered assuming exponential softening for the tensile behavior and parabolic hardening followed by softening for the compressive behavior. The crack bandwidth  $h$  for the shell elements was estimated as function of the area of the element  $A$ , making the analysis results independent of the size of the finite element mesh:

$$h = \sqrt{A} \tag{1}$$

**Table 3** Calibrate Young's modulus and nonlinear properties

	Young's modulus $E$ (GPa)	Compressive strength $f_c$ (MPa)	Compressive fracture energy $G_c$ (N/mm)	Tensile strength $f_t$ (MPa)	Mode I tensile fracture energy $G_t$ (N/mm)
Element 1, 3–11, 13–19 <sup>a</sup>	1.00	1.43	2.29	0.10	0.02
Element 2, 12 <sup>a</sup>	1.33	1.90	3.04	0.10	0.02
Vaults	1.18	1.68	2.31	0.10	0.02
Concrete elements	19.27	–	–	–	–

<sup>a</sup>See Fig. 12b

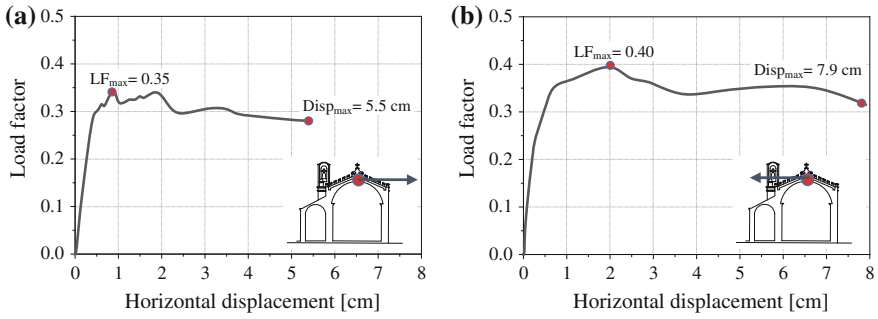
The nonlinear properties assumed for the masonry elements, namely compressive strength, the compressive fracture energy, the tensile strength, and the tensile fracture energy, are presented in Table 3.

## 7 Seismic Analysis

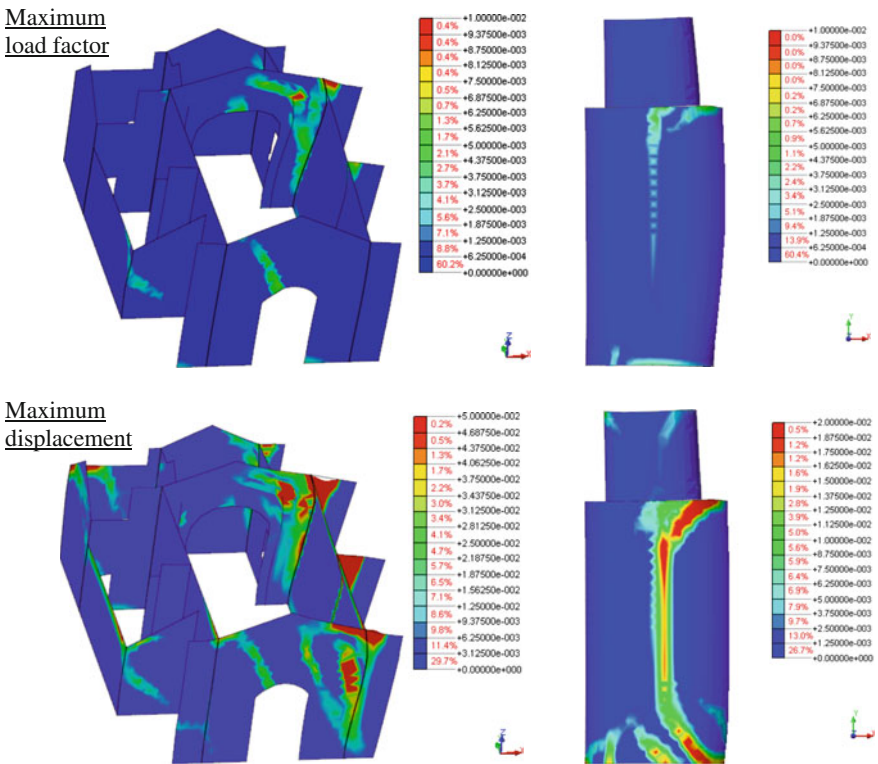
The seismic analysis was performed aiming at evaluating the seismic performance of the church in terms of maximum force and damage. In the seismic analysis, the pushover analysis with horizontal load pattern proportional to the mass of the structure was adopted, which corresponds to the first distribution of lateral forces defined by Eurocode 8 (uniform pattern) (EN 1998). Four pushover analyses were carried, namely the two pushover analyses in transversal direction (+X and -X) and two longitudinal analyses in the longitudinal direction (+Y and -Y). The response of the church was evaluated based on the capacity curves, which corresponds to the relationship between the load factor and the displacement at the control point, and the tensile principal strains (indicator of cracking). The load factor corresponds to the relationship between the total horizontal force at the base and the self-weight.

In the capacity curves of the pushover analysis in the transversal direction, the horizontal displacement at the top of the vault and at middle of the nave was assumed as control point (Fig. 14). The results show that the maximum capacity in the transversal direction is equal to 0.35 and 0.40 in the positive (+X) and negative direction (-X), respectively.

In the pushover analysis in the transversal (+X), the damage concentrates at the main façade and at the South corner of the arch chancel for the maximum load factor (displacement equal to 0.9 cm) (Fig. 15). At the end of this analysis (displacement equal to 5.5 cm), the structure presents severe damage at the main façade, namely diagonal crack near the opening and the south corner. The top of the south buttresses and the chancel arch presents also severe damage. The vault of the

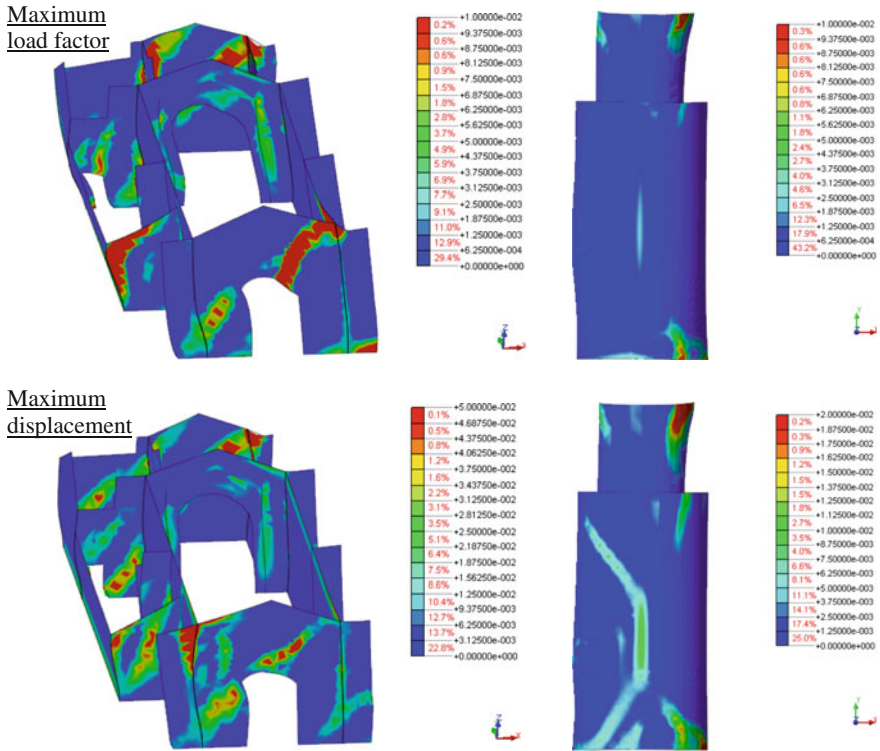


**Fig. 14** Capacity curves for the pushover analysis in the transversal direction (X direction): **a** +X direction; **b** -X direction



**Fig. 15** Tensile principal strains for the pushover analysis in the +X direction

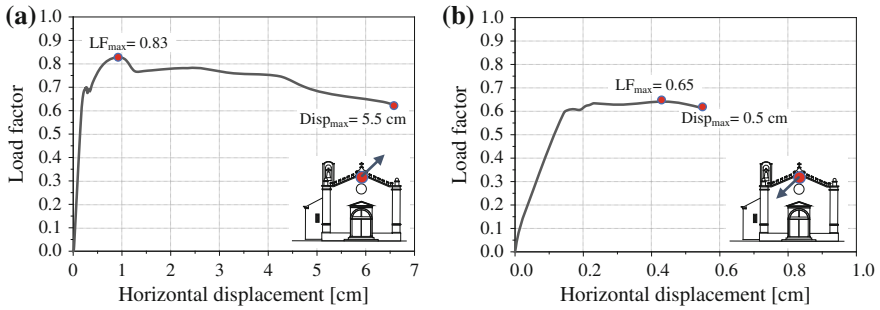
nave presents a crack at the middle span and diagonal cracks in the direction of the south corners (intrados surface). The corners northeast of the sacristy and northwest of the corridor present moderate damage.



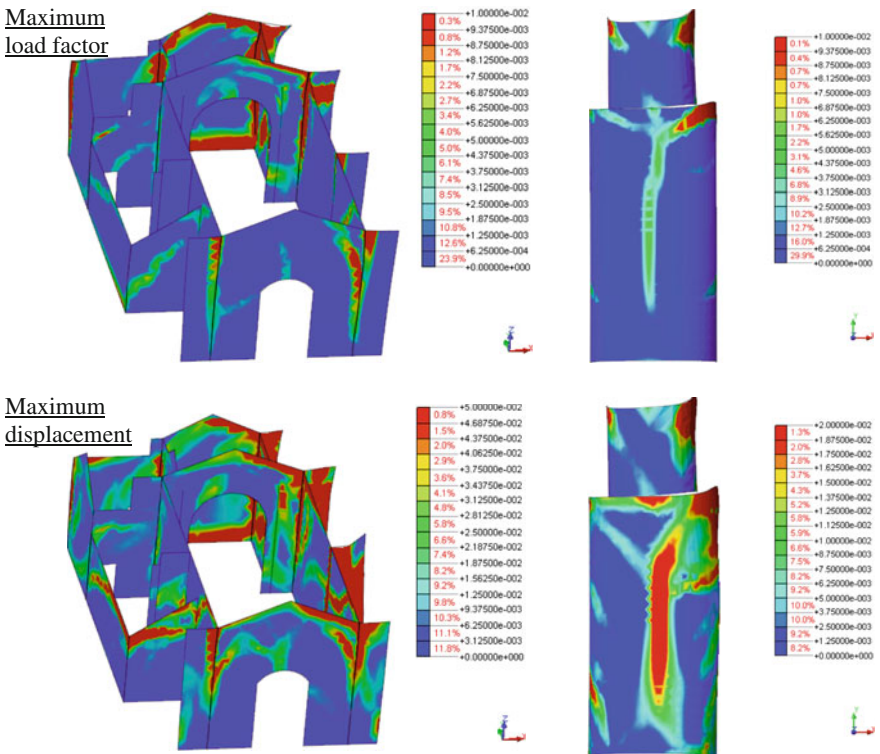
**Fig. 16** Tensile principal strains for the pushover analysis in the  $-X$  direction

In the positive direction of the pushover analysis in the transversal direction (Fig. 16), the results show that for the maximum load factor (displacement equal to 2.1 cm) the transversal walls present shear cracks, mainly the main façade and east wall of the chancel and corridor. For the maximum displacement (7.9 cm), the structure presents severe crack at all transversal walls of the sacristy and corridor. The main façade and the transversal wall of the chancel present also severe diagonal cracks. The east buttress of the main façade presents severe damage at the top in the connection with the façade. The vault presents moderate damage, with a crack at middle span and diagonal cracks in the direction of the north corners (intrados surface). In both pushover analyses in the transversal direction ( $+X$  and  $-X$ ), the longitudinal walls of the nave do not present high displacement in the transversal direction at the middle of nave, indicating that the buttresses prevent the out-of-plane displacements of these walls.

In the capacity curves in the longitudinal direction, the point at the top of the main façade was adopted for controlling the response of the structure (Fig. 17). The maximum load factor is equal to 0.83 and 0.65 for the pushover analysis in the positive direction ( $+Y$ ) and negative direction ( $-Y$ ), which corresponds to an average about the double of the maximum load factor in the transversal direction.

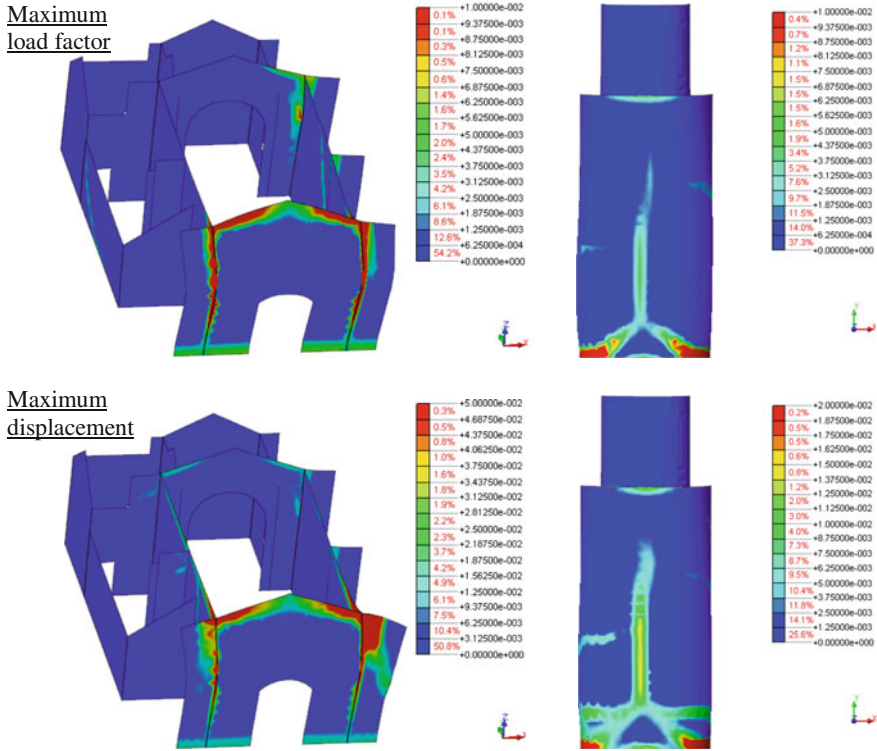


**Fig. 17** Capacity curves for the pushover analysis in the longitudinal direction (Y direction): **a** +Y direction; **b** -Y direction



**Fig. 18** Tensile principal strains for the pushover analysis in the +Y direction

In the positive direction of the pushover in the longitudinal direction (Fig. 18), the structure presents damage at the walls of the chancel, mainly at the southeast corner, at the connection of the main façade with the buttresses, at the top of northwest corner of the corridor, and at the south buttresses. The vault of the nave



**Fig. 19** Tensile principal strains for the pushover analysis in the  $-Y$  direction

presents damage severe at the middle span and near the southeast corner of the nave. The response of the pushover analysis in the negative longitudinal direction (Fig. 19) corresponds to the out-of-plane local collapse of the main façade, presenting severe carracks at the connections with the buttresses.

## 8 Conclusions

The Our Lady of Conception church is located in Monforte (Portugal) is classified as a Public Interest Building. The church is not in use nowadays and presents severe damage, which requires a multidisciplinary teamwork to evaluate the conservation status of the church, involving civil engineers, architects, restoration technicians, geologists, and archaeologists. Thus, the diagnosis and structural analysis of the church were carried out, involving the damage survey, dynamic identification test, and seismic analysis.

In general, the masonry walls are in good conditions, with the exception of the transversal walls of the nave, which present severe cracks, mainly near the corners.

The nave presents also severe damage at the ribs of the vault. The infiltrations of the rainwaters have increased the degradation of the vault and paintings. Furthermore, the external floor presents settlements in the southwest direction.

The dynamic identification test allowed to estimate the dynamic properties of the church, namely frequencies, mode shapes, and damping ratios.

A FEM numerical model was prepared and calibrated, based on the first four experimental modes, in which the average error between the experimental and numerical frequencies of about 4 % for the first four modes was obtained.

The seismic performance of the church was evaluated through the pushover analysis with load pattern proportional to the mass. Two analyses in the transversal direction (positive direction and negative direction) and two analyses in the longitudinal direction (positive direction and negative direction) were carried out. The results allowed to conclude that the transversal direction corresponds to the most vulnerable direction of the church with load factor equal to 0.35. In the pushover analysis in the transversal direction, the structure presents severe diagonal cracks in the transversal direction. The vault of the nave presents also severe damage. The buttresses are able to prevent the out-of-plane displacements of the longitudinal walls of the nave. The pushover analyses in the longitudinal direction presented the lowest maximum load factor in negative direction (0.65), in which the church presents the local out-of-plane collapse of the main façade.

## References

- DGMEN (1973) Descriptive document, process 372 our lady of conception church, sipa, directorate general for national buildings and monuments, regional directorate of buildings and monuments of the south, Évora, Portugal (In Portuguese)
- Douglas B, Reid W (1982) Dynamic tests and system identification of bridges. *J Struct Div* 108(10):2295–2312
- EN 1998-1 (2004) Eurocode 8: Design of structures for earthquake resistance—general rules, seismic actions and rules for building. European Committee for Standardization
- ICOMOS (2005) Recommendation for the analysis, conservation and structural restoration of architectural heritage. International Council on Monument and Sites
- Lourenço PB (1996) Computational strategies for masonry structures. PhD Thesis, Delft University of Technology, Netherlands
- Mindlin RD (1995) Influence of rotary inertia and shear on flexural motions of isotropic elastic plates. *J Appl Mech* 18:31–38
- Monforte Municipal Council (1774–1853) Book of expenses of the our lady of conception church. Portugal (In Portuguese)
- Reissner E (1945) The effect of transverse shear deformation on the bending of elastic plates. *J Appl Mech* 12:68–77
- Silva E (2000) The chapel of our lady of conception. Analytical and descriptive study, equipment, artistic and restoration programs. Master Thesis on Culture and Municipal Training, Technical University of Lisbon, Portugal (In Portuguese)
- TNO (2015) Displacement method ANALyser. User's Manual, Release 9.6, Netherlands

# Brutalist Architecture and Pathologies: How Design Mistakes Can Make a Building “Sick” from the Beginning

Francesco Paolo R. Marino and Filiberto Lembo

**Abstract** The monumental building, formerly the seat of the Mediterranean Bank in Potenza, whose project dates back to 1976 and which was built between 1982 and 1985, proposing design modules and compositional structure of the *Castle of Lagopesole*, by Federico II of Swabia, is today a sad empty container. After about a decade of use, i.e., until the end of the 1990s, the building was abandoned, as its use was no longer economically viable. In fact, it was built with reinforced facing concrete walls, not isolated either inside or outside; flat roofs are not insulated; curtain wall fixtures are bad-performing in terms of heat loss. It has a large skylight, made almost horizontally, a cascade of glass cubes which covers the central hall. At present, spalling of concrete is diffusing, molds are spreading on the inner face of the exterior walls, and roofs are leaking. The interest in the described building was born from the appreciation of the architectural value of a *brutalist* work of contemporary architecture, paradigmatic, and relevant both for its many cultural and architectural references, and both for the originality demonstrated in the synthesis of different languages attributable to the current period, as well as for the typical pathologies of a building with walls made of facing reinforced concrete. The aim of the work was to demonstrate how it is possible to work on a building representative of *brutalist architecture* in Italy, correcting the pathologies and turning it into an energy-efficient building, without changing its formal aspect.

**Keywords** Brutalist architecture · Pathologies · Facing reinforced concrete

---

F.P.R. Marino (✉) · F. Lembo  
School of Engineering, University of Basilicata, 10 Viale Dell’Ateneo Lucano,  
85100 Potenza, Italy  
e-mail: francesco.marino@unibas.it

F. Lembo  
e-mail: filiberto.marino@unibas.it



## 1 Introduction

In the 1980s, in southern Italy, as in much of Europe, the Brutalist movement has spread the architectural current view as the overcoming of the Modern Movement in architecture. Originated in England in 1954 by Alison and Peter Smithson, theorized by Reyner Banham (Banham 1955), practiced by Le Corbusier, Atelier 5, and Denys Lasdun, and in Italy by Vittorio Viganò and Carlo Scarpa, *brutalism* often employs the harshness of the facing reinforced concrete, which worked and molded plastic forms in detail (as in *pilotis* or for the chimneys of “Unité d’Habitation”), and shows with great expressive force structure and building materials. There is no denying, of course, that the term “*Brutalist*” has changed over time as a meaning so broad and all-encompassing as to incorporate in it all that was not strictly to do with the cultural approach of that period, so that it has become no longer the term used to designate an architectural philosophy but a way of building, although it is undeniable that all reinforced concrete buildings constructed during this period can be called brutalist, thus having to make a distinction between what is fashionable and what is springing up spontaneously as a result of a historical and cultural context.

A paradigmatic building of this *brutalist architecture* is, in the city of Potenza, the seat of the Mediterranean Bank (Lembo 2014). Designed in 1976 by the architect Dante B. Maggio (Maggio 1985), and built in the years between 1982 and 1985, it adopts these suggestions in clear contrast between solid walls in *béton brut* and curtain wall façades in black aluminum and semi-reflective glass: explicit reference to the nearby Lagopesole’s castle, built by the Normans and then expanded by Frederick II of Swabia, of which it takes its orientation, the module design of the “Frederick cubit” (55 cm) and the four corner towers (Fig. 1).

This building, along with others (Lembo and Marino 2015) which are in Potenza and its province (among them, some schools, a psychiatric hospital and the court), has the typical problems of an architecture with the facing concrete, linked to the lack of thermal insulations, and then in the presence of not controlled thermal losses, which cause pathologies by wet type. In this work, we wanted to find a



**Fig. 1** West (on the *left*) and south (on the *right*) view

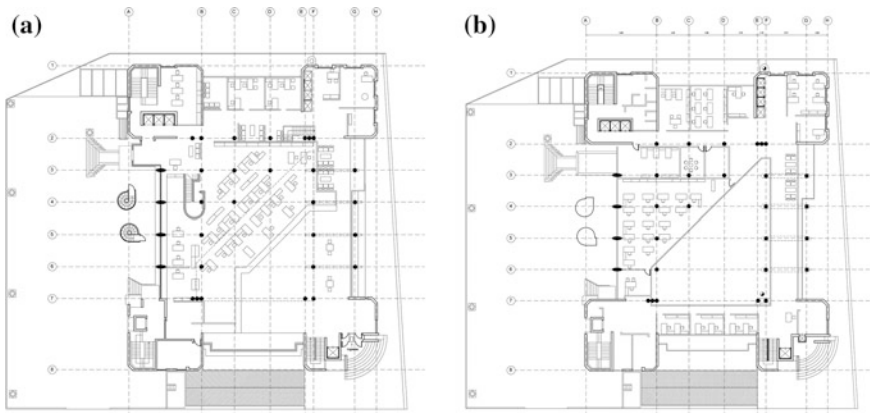
method of intervention, of recovery and of technological upgrade, in particular of the thermal type, specific and usable in all cases of “brutalist” architecture, with the additional constraint of obtaining a result that would preserve formal values of the textural image of the original building.

## 2 The Building Case Study

The project covers a batch of 3000 m<sup>2</sup> large almost square. To the dictates of the *brutalist architecture*, the construction technique is that of cast-in-place reinforced concrete, in formworks of different shape and size, left face view. The planimetric layout consists of a central hall surrounded by four towers that stand out at the corners of the building.

The ground floor (Fig. 2a, on the left) has a very large hall, where they were bank branches for the public; the space is illuminated by the skylight above and has two entrances: The entrance for clients is located in the northwest tower, on the corner of the building, in a space that seems to be sculpted according to the stepped elements that are strongly reminiscent of those of Carlo Scarpa architecture; the entrance for employees is placed, instead, on the east side of the building, laterally with respect to the whole prospect, through a walkway elevated above the floor of the square, seems to mark an image of a drawbridge that leads into of a castle.

The central room is triple height, topped by a steel and glass roof, articulated in three dimensions in a pattern rather complex. Around the central atrium, for the reception of bank customers, they are organized functional spaces for the offices that overlook the central space through a series of galleries, which have a dual function: to connect the various offices and that of “architectural promenade,” through which it is possible to fully appreciate the spatial deployment of roof



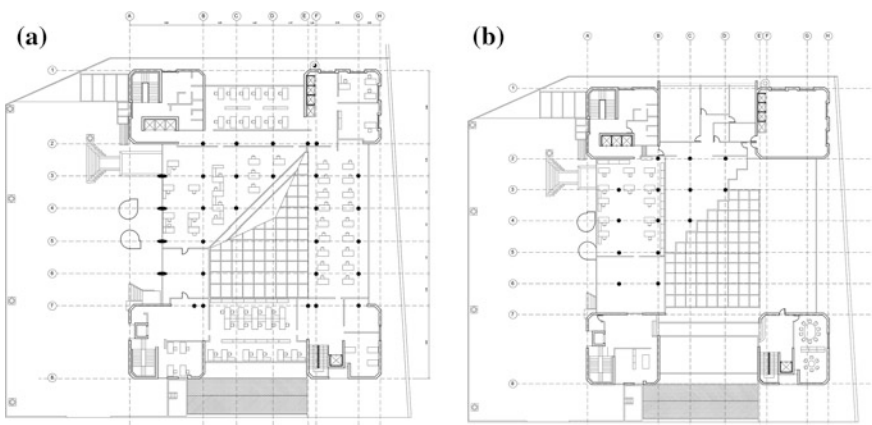
**Fig. 2** Ground-floor plan (on the left) and first floor plan (on the right)

skylight. The spaces are placed in vaults in the underground floors, surrounded by thick walls of concrete, reinforced internally with steel rods embedded in the concrete in order to ensure utmost safety. Both car parks are located in the first and second basement, which is accessed via the ramp to the north of the building; basements are surrounded by an interspace surrounding the structure of the building and are connected to ground through a number of vents that allow ventilation of the floors below, in accordance with the current regulations for underground parking. In addition, many areas were to warehouses and storage facilities and were used to host the archives of the bank, in addition to the space containing the safety deposit boxes.

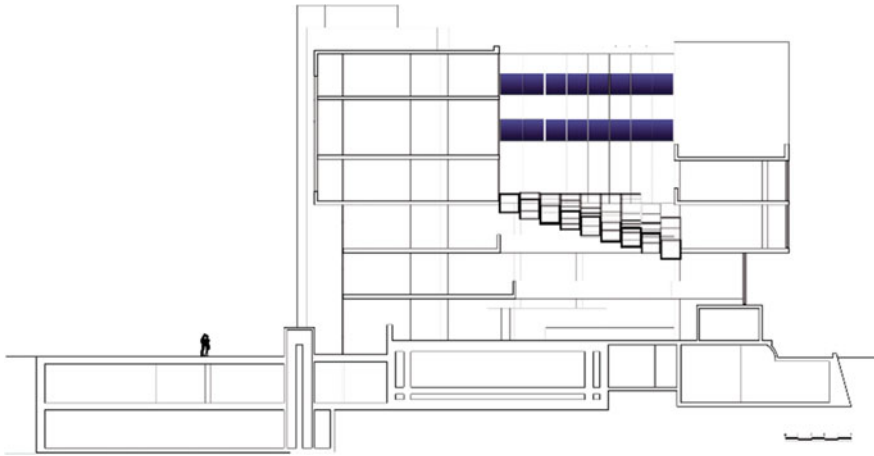
The first floor (Fig. 2b, on the right) is divided by movable partitions: It is organized around the central atrium space and used to house the offices of the employees. In the towers to the south and the northeast tower are located 3 stairwells and elevators, while in the northwest tower are located offices of employees and 3 lifts.

At the third level (Fig. 3a, on the left), a gallery in transparent Plexiglas and aluminum connects the northeast tower to the northwest. From the northwest tower, it is possible to reach the third level, and in particular, the terrace, from which it is observed, in all its complexity, roof skylight surmounting the central atrium.

The perspective view from this terrace allows to perceive in a complete way the terraced step structure of the cover, which is constituted by steel cubic elements arranged according to two different gradients covering an altitude difference of two floors. The internal face is similarly marked by a terraced step plan that allows to have a clear correspondence between the cover and the underlying structure in elevation. The rhythm is punctuated by alternating between opaque and transparent parts constituted by ribbon windows. The fourth level (Fig. 3b, on the right) was used for the computer center of the bank; at present, the raised floor needs to be



**Fig. 3** Third-floor plan (on the left) and fourth-floor plan (on the right)



**Fig. 4** East–west section

replaced due to the markedly state of degradation of the same which prevents the practicability in complete safety.

The finishes, present in all areas, are of value, characterized by the presence of marble flooring, regarding almost all of the spaces, and a parquet flooring in the spaces which house the rooms of the presidency. The linings of stairways are granite with stainless steel railings, while the interior walls are facing reinforced concrete, modeled on variations dictated by the needs of a formal nature that required the use of different formworks.

Without a doubt, the focal elements of the building are represented by the towers that mark the rhythm of prospects through alternation of opaque elements in reinforced concrete and transparent elements, namely the large glass walls on different fronts.

All the design elements tend to accentuate and confer a strong austere monumentality, which is, however, dampened by the presence of light inside the building and an emotional contact with the landscape given by the effect of the mirrored glass of the curtain wall (see Fig. 4). The base is heavily marked to emphasize the strong connection to the land and to emphasize the safety of the building well anchored to the ground.

### **3 Analysis of the Decay and Pathologies**

The problems related to the building process of decay are caused by some factors that essentially make reference to absence of insulation, thermal losses, and humidity coming from the cover. Neglect and abandonment of the building led to

the consequences that are visible at the external walls of the building and inside. In general, the covers have proved to be badly designed (Marino 2013).

The lack of adequate waterproofing causes the penetration of water into the building, resulting in the clear detachment of plaster on the top floor; the inadequacy of the slopes accentuates the inability to evacuate the rainwater that is determined by the modest effectiveness of the water disposal system: Water stagnates on the covers so as to become a quagmire, with penetrations in many points; standing water is visibly present even within the frames of the roof, as well as on the tempered glass windows on the roof of the hall, which realize a skylight of degrading cubic elements made of stainless steel, covered by nearly horizontal tempered glass (Fig. 5).

Finally, the continuous exposure of the façades in facing reinforced concrete, that is, devoid of any coating and/or protection against atmospheric agents, has also caused the leaching of the surfaces in more points. The small concrete reinforcement cover has caused, in several places, spalling of concrete *béton brut* (Fig. 6).



**Fig. 5** Design errors and defects of the cover: water stagnation (on the *left* and *center*) and decay of the roof waterproofing (on the *right*)



**Fig. 6** Leaching on the surfaces of facing reinforced concrete (on the *left*); corrosion of reinforced steel (on the *center*); exposure of reinforcing bars (on the *right*)



**Fig. 7** Efflorescence and surface wash in the stairwells (on the *left*) and on the floors of the higher levels corrosion (on the *center*); gallery decay (on the *right*)

Efflorescence and surface wash are present in the stairwells and in the lower surface of the floors of the third and fifth levels. The gallery presents water infiltration, detachment of plaster from the parapets, and degradation of transparent Plexiglas cover (Fig. 7).

However, one of the most invasive problems is the large thermal losses of the external walls, made of reinforced concrete and partially by the continuous glazed façades. And, the absence of adequate insulation, which makes a building “eats energy,” is today a new type of pathology which might be called “pathology of poor energy efficiency”: The building consumes too much energy, and after a fixed period of time, spending is no longer sustainable.

So much so that, at a distance of just 16 years after its completion, around 2001, the building was abandoned, because of its too high cost of use and exercise.

In fact, overall, the building has a surface bounding the heated volume of 6410 m<sup>2</sup>, a gross heated volume of 20,500 m<sup>3</sup>, and a useful floor area of 11,400 m<sup>2</sup> (which determines the S/V ratio of 0.31); on a site such as Potenza (latitude 40° 38', longitude 15° 48', 819 m *osl*, 2472 degree-days, Climatic Zone E, heating days 183, external reference temperature −3 °C), the building is practically devoid of insulation: its reinforced concrete walls and the lower and the upper frontier have a  $U$  of 3.07 W/(m<sup>2</sup> K), and its windows a  $U_w$  value of 2.64 W/(m<sup>2</sup> K), when it is not even 5.5 W/(m<sup>2</sup> K) as in the case of the tempered glass window on the hall; its annual heat demand is 69 kWh/m<sup>3</sup> year.

## 4 Solutions Proposed in the Retrofit Project

Thus, in our case study, the lack of adequate isolation has prevented the use of the building, as to be forced to abandon it for managerial and economic reasons. The inability to reduce energy consumption of the building has laid the important

question of finding a design solution to recover this building, both from the functional and technological point of view.

The first requirement was to provide a heavily insulated and ventilated casing, in order to allow the heating and cooling of the building (air conditioned) as possible in a “passive” and “natural” manner, enhancing the great thermal inertia of its heavy concrete walls ( $750 \text{ kg/m}^2$ ). Through the use of Ecotect Analysis software, it was possible to perform this analysis, including solar and thermal, on the building “as built” (Fig. 8).

This allowed us to perform some checks on the sunshine of different fronts of the building, so as to be able to correctly identify the interventions to be carried out at the design stage of the retrofitting intervention. The diagrams thus obtained represent the temperature trend in the homogeneous thermal zones in the different days of the year. Also, heat gains and energy losses were calculated by a comparison of the different periods of the year (Fig. 9).

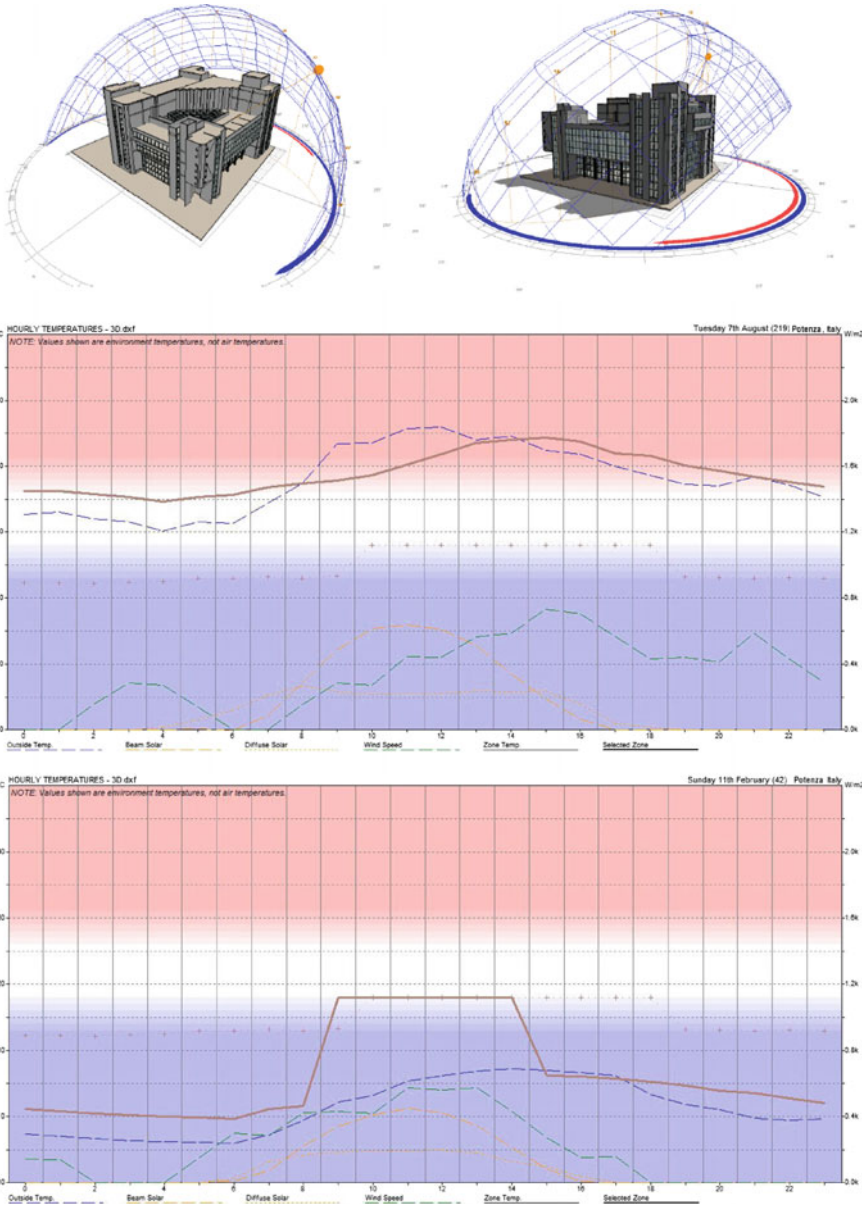
To successfully intervene on a building of this type, it is necessary to operate in the direction of reducing consumption and increase its energy efficiency. These interventions should focus on the following: the structural insulation of the building; the heating system and air-conditioning upgrading, from the boiler to the diffusers, and control of natural and forced ventilation; management, how to use the building and the facility.

In particular, the correct level of insulation of the building is achieved through the following: the roofing insulation; insulation of the envelope, possibly perimeter type, from the outside, cladding, or ventilated wall insulation; and installation of more efficient doors and windows. On the market of more sophisticated building systems, we have been searching an advanced rainscreen, continuous, ventilated (to remove the heat irradiation in summer), durable, which could materially be treated similar to a facing reinforced concrete.

It was chosen StoVentec Render system, based on the use of sustaining plaster recycled glass plates, 1.2 cm thick, screwed with stainless steel screws to a sub-structure of extruded aluminum profiles. These aluminum profiles are supported by the brackets in stainless steel, such as hinges or carriages, for connection to the support wall. On the plates is disposed an organic plaster, armed with a glass fiber mesh, using the finish “Betonoptik” that, both in the views from afar that in those closely, is very similar in color, grain, and texture, to *béton brut* (Fig. 10).

Naturally, the ventilated rainscreen is mounted after the concrete surface is cured flaking with the usual methods for the rehabilitation of reinforced concrete surfaces, and the application with plugs of 20 cm of mineral wool 035, with which is obtained for the wall a U value of  $0.166 \text{ W (m}^2 \text{ K)}$ .

The existing *curtain wall* has been left in place, but doubled to form a practicable ventilated interspace, as double skin façade, which is useful both to prevent overheating in summer and to reduce winter heat loss.



**Fig. 8** Some examples of the analysis performed with the Ecotect software: solar analysis (*up*); hourly temperature hottest day (in the *middle*); hourly temperature coldest day (*down*)



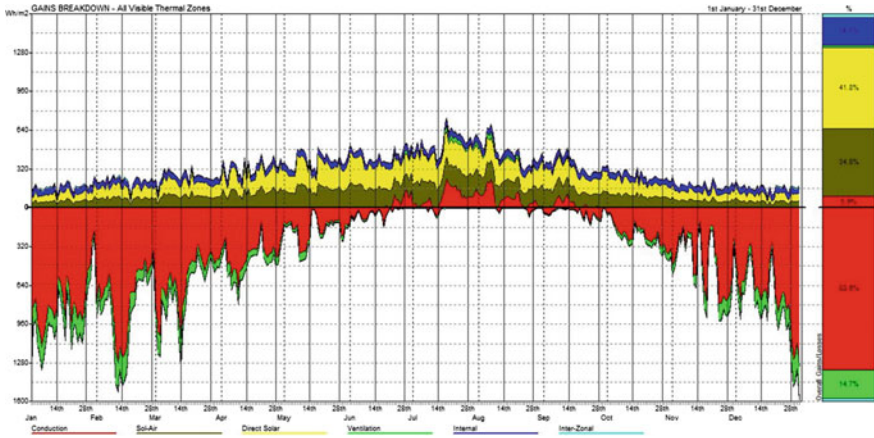


Fig. 9 Gains breakdown for all visible thermal zones, from 1st January to 31st December



Fig. 10 Recovery project: axonometric views

Using a specific calculation software developed by the authors (Lembo et al. 2007), the width of 60 cm was calculated as the optimal thickness of the interspace, and the DSF is sectioned horizontally, in correspondence of each floor, for partitioning it according to fire protection. The result is a drastic improvement in

performance, both in summer and in winter, of the transparent envelope, scored again through Ecotect.

Improvement even more pronounced thanks to the production of energy obtained with the solar panels that have been included on the DSF wherever it has been possible. To solve the problems of the central atrium glass roof, the choice was to clean it and leave it in place, and to create a new cover with a different configuration and softer, completely outside and above the atrium, made with high-performance glazing, able to gather and download the rainwater directly on the roof, with additional downspouts (see Fig. 10, picture down on the right).

On the covers, rehabilitated and thermally insulated, it is thus possible to carry out fundamental reductions in energy consumption and performance improvements in both summer and winter until a transmittance value of  $U = 0.16 \text{ W}/(\text{m}^2 \text{ K})$ . It was also planned the placement of solar p.v. panels to the depletion of the free-sun surface. Regarding the heat and ventilation facility, it was planned the replacement of the heat generator with a more modern and efficient, and the revision of the refrigeration units.

## 5 Conclusions

With the proposed interventions, defects and pathologies found on the building case study have all been resolved.

The most important result was to have performed an economically sustainable refurbishment intervention, which, as proved by analytical evaluations and simulation models, has led to the following: the duration of the useful life of the building from 90 to 120 years of age; the current market value to €7,914,000.00 (with a processing cost that is of a value of €2,250,000.00 and transformation that is €4,679,000.00); savings of natural gas consumption by 10 times (up from 141,033 to 14,698 kWh/year).

The saving of methane (capitalized in 15 years amounts to €1,385,987.30 for heating costs) led to a substantial reduction in exercise costs of the building case study and has largely solved the so-called *pathology of poor energy efficiency*. In fact, the reduction of natural gas consumption, combined with other interventions provided on the air-conditioning and ventilation systems, and the gain arising from the photovoltaic panels, ensures that the building is positioned in energy Class A, with an Epi equal to  $17 \text{ kWh}/\text{m}^3 \text{ year}$  (Marino and Grieco 2009).

In this research, it has reached the expected results to identify a method of intervention, economically sustainable and advantageous, to recover and upgrade, especially on the thermal point of view, a “*brutalist*” architecture, perfectly compatible with the conservation of the formal characteristics of the building, expression of the relevant international architectural culture of the 900s in Italy.

**Contributions** The contribution of the authors in the research and in editing and writing the text of the paper was equal.

## References

- Banham R (1955) The new brutalism. *Architectural Rev* 708:357
- Lembo F, Marino FPR, Lacava G (2007) Double Skin Façades: definition of an ideal depth for cavities. In: Abbott C, Aquad G, Kagioglu M, Ruddock L (eds) *Proceeding 4th international research symposium (SCRI), Salford (Greater Manchester), University of Salford (UK)*, pp 147–160. ISBN:9781905732210
- Lembo F (2014) Transforming a brutalist monument into an energy efficient building without destroying the formal appealing: the example of the Mediterranean Bank in Potenza (Italy). In: Oral AY, Bahsi ZB, Ozer M (eds) *International congress on energy efficiency and energy related materials (ENEFM 2013), Springer proceedings in physics 155*, pp 83–90. doi:10.10007/978-3-319-05521-3\_11, ISBN:978-3-319-05520-6, ISSN:0930-8989
- Lembo F, Marino FPR (2015) The High School “Giustino Fortunato” in Rionero in Vulture (Potenza, Italy): how to refurbish an higher education institute made in *brutalist architecture* of ‘80, leading it to be a NZEB and preserving its formal features. In: Quattrone M, John VM, XIII International conference on durability of building materials and components—XIII DBMC, publication RILEM Pro096, pp 744–751. e-ISBN:978-2-35158-149-0
- Maggio DB (1985) *Il palazzo della Banca Popolare di Pescopagano 1976–1985*, texts by Gillo Dorfles e Benedetto Gravagnuolo. Milano, Mazzotta Editore
- Marino FPR, Grieco M (2009) *La certificazione energetica degli edifici. D.Lgs. 192/2005 e 311/2006—IV edizione aggiornata alle UNI TS 11300—Algoritmi di calcolo ed esperienze internazionali. Edifici ad alta efficienza, EPC Libri, Roma*, pp 720, ISBN:978-88-6310-113-3
- Marino FPR (2013) Relations among pathologies, building technologies and building typologies. In: De Freitas VP (ed) *A state-of-the-art report on building pathology*, CIB - International Council for Building, W086 building pathology. CIB Publication 393, Rotterdam (NL), pp 153–159. ISBN:978-90-6363-082-9

# Basis of Stone Panel Pathology and Application of Infrared Thermography in the Pathology Study of Back-Ventilated Façades with Stone Panels

C. Lerma, V. Blasco, Á. Mas, E. Gil and J. Vercher

**Abstract** The technique of back-ventilated façades with stone panels has been used very much over the last decades. They have replaced the buildings designed with blocks or masonry. The holding technique of these panels has been usually solved by specific anchorage points, with pin, cylindrical rod, or flat bar. One of the most common injuries on these building façade is a shear failure with frustoconical shape. The aim of this research is to study the causes that led this pathology in a particular building of Valencia (Spain). This is the tourist office, built with stone panels of sandstone. We analyze the material composition, as well as cyclic and wetting–drying tests. Non-destructive techniques have many advantages, and in this research, we have used thermal imaging technology. To identify and diagnose these stone defects, we have used specifically the passive thermography, which uses the Sun's energy to heat and cool the building materials. An early identification of pathology in the building façades can be very interesting to be able to repair or replace the panels before they are detached from the anchors.

**Keywords** Stone panels · Anchorage points · Natural stone · Thermography · Durability

---

C. Lerma (✉) · V. Blasco · Á. Mas · E. Gil · J. Vercher  
Universitat Politècnica de València, Cmno. de Vera S/N, Valencia, Spain  
e-mail: clerma@csa.upv.es

V. Blasco  
e-mail: vblasco@csa.upv.es

Á. Mas  
e-mail: amas@csa.upv.es

E. Gil  
e-mail: egil@upv.es

J. Vercher  
e-mail: jvercher@csa.upv.es

## 1 Stone Panels Without Air Chamber

Panels compose discontinuous coverings. These parts must be less than 50 kg in weight to be handled by one or two operators. Regarding the minimum recommended thickness, according to the Spanish legislation, the Technical Building Code called *Código Técnico de la Edificación* (CTE Spanish standard 2009, 2010, 2013, 2014) is 30 mm. The maximum surface must be 0.80 m<sup>2</sup>. If the panel dimension is large, the risk of breakage and deformations slenderness increases. Separators or 2-mm PVC spacers between panels are used to place the pieces. They absorb the small format differences between panels. Subsequent grouting facilitates the waterproofing joints if there is no air chamber on the facade. To attach or anchor the pieces, we use anchors, stainless metal elements of attachment to the support. They guarantee stability and security. They can be installed in two ways:

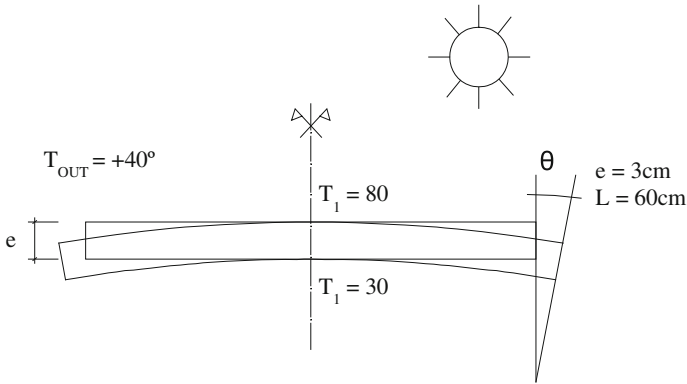
- (a) Stability of each panel against all types of actions.
- (b) Several row only with anchors to prevent overturning, transmitting its weight to a fully stabilized row with more robust anchors that they can be transfer the weight of the panels to the structure.

We must use installation mortar to fill the gap between plate and its support (Fig. 1), 1:4 dosage mortars and plastic consistency poured into tiers of 20 cm and crushed with rod or punch, being careful with the voids. We fill the joints with grout or mortar with fine aggregate adding, if necessary, water repellents for grouting.

Support for this type of enclosures should be thick mass and stiffness to weight ratio of stone panels. It is advisable, at least, a sheet of perforated brick for 30-mm-thick panels. The wall thickness increases with thicker panels. Adherence with mortar improved if we split or scratched the surface with concrete support.

**Fig. 1** Panels without air chamber and with filling mortar backfill





**Fig. 2** Panel deformation due to the difference between the outside and the inside surface temperature

### 1.1 Behavior Problems in Small-Thickness Panels

The deformation of the panels is very likely with thickness below 30 mm. Water entry through the joints occurs due to thermal movements and mortar retraction, opening microjoints that absorb water by capillary action.

The mortar retains water which tends to be eliminated through the joints when precipitation is interrupted.

Another problem is the differential drying between the panels' edges and central areas of the panels (Fig. 2). Irregular concentrations of dark and wetter areas in certain areas of the panels after several days of rainfall may occur.

An air chamber between the outer and inner sheet, improving the appearance with collection and/or drain, allows water drainage and prevents water entry. However, in this type of façades without air chamber, you can prevent water entry sealing the joints with silicone.

Panels' treatment may be performed by treating the outer surface of the panels with water repellents based on silanes or siloxanes, which are impermeable water-repellent resins and allow vapor diffusion.

## 2 Panels with Air Chamber

The following design criteria can be used in exterior walls with small-thickness panels:

- To use stone that can be able to resist extremes of climate, the most used are granite and marble.
- To provide expansion joints.

- To provide an effective anchor.
- To resolve requiring waterproofness in the outer sheet.
- To provide drains if we accept that water will enter through the cladding.
- Complementary elements (railings, lattice, fences, umbrellas, etc.) must be anchored independently to structural elements.

The requirements to be met by the material of the stone panels are different. Homogeneity and continuity are important. To check porosity in order that does not absorb water by capillary action. To check permeability, if the stone is hygroscopic. To check hardness, because it determines the usability and finishes that you can receive. To analyze that there are no microcracks and meet the mechanical properties of tensile, compression, bending, and impact. Also important is the durability of the initial characteristics after prolonged exposure to solar action.

After cutting, panels can be fissured during transport or placement. Furthermore, we can be cautious and reinforce in the hidden face, e.g. with glass fiber reinforcement. The development of this type of enclosure or discontinuous facade requires a placement requirement of stone panels: ease of installation, ease of maintenance, and adequate drilling of parts not to reduce its strength. If we drill, the piece must test the resistance thereafter (Fig. 3).

Walls designed to achieve a high degree of air pressure equalization between the inner cavity and the exterior, obtaining considerable benefits, are known as pressure-equalized rainscreen (PER) walls. Existing design guidelines on these walls are mainly qualitative and referred to a theoretical continuous wall, with few references to real construction methods or discontinuities of the facade. Behavior of PER walls, when built with stone panels of medium thickness (30–40 mm) and open horizontal and vertical joints. Although panels of 12–20 mm thickness are often used in many countries (Mas et al. 2010).



**Fig. 3** Photograph of a stone panel with air chamber

### 3 Anchors

We will use an auxiliary structure and/or anchors. This auxiliary structure must be anchored to the main structure.

Anchors are fixed to the inner surface of the panels, if we use them. These anchors can be embedded (Fig. 4) or with mechanical fixing (Quintáns 1996). Embedded anchors cannot be used on concrete surfaces or metallic structures because we cannot drill the support. Mechanically fixed anchors are not used in hollow brick supports or in building blocks (either concrete or ceramic blocks). Anchors fixed to a substructure can be used in all types of supports.

#### 3.1 Anchors Requirements

One of the main requirements for panel anchors is the unalterability to water. The oxidation causes an increase in volume that would burst the fixing area. Decreasing section in this area will create a risk of falling. The resistance to the weight of the supported parts determines the size and the type of anchors.

Other requirements that we must check are the failing strength and the over-turning of the panel, mechanical stress resistance to wind, adaptability to the

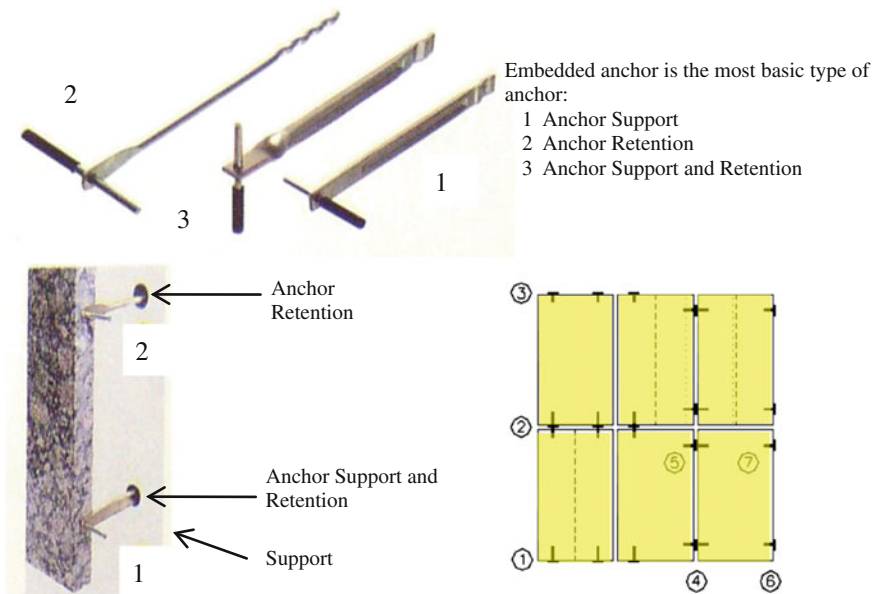


Fig. 4 Types of panel anchors



structural support, the opportunity to correct errors, as, e.g., the lack of adequate flatness and the ease of change for any broken component.

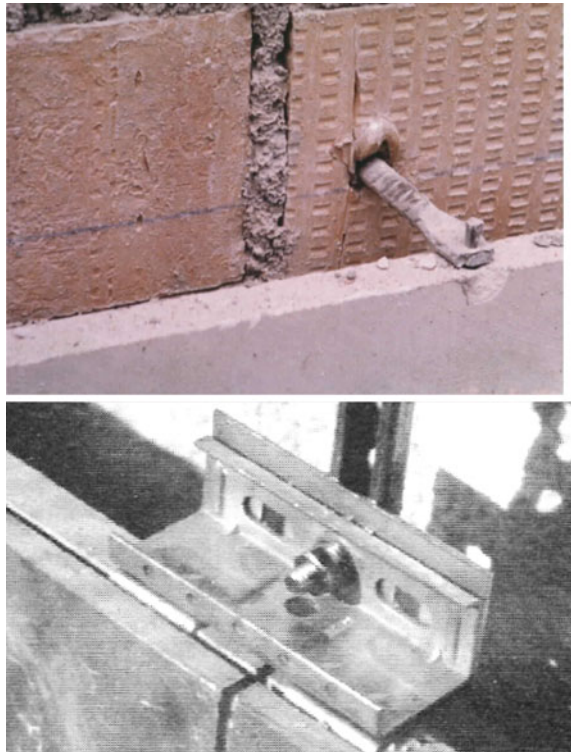
The anchor-plate link must allow the anchors transmission of the loads applied on the panels and anchor movements (structure deformations), without creating stone stress.

### 3.2 *Types of Anchors*

Basically, there are two types of anchoring, rod and pin (Fig. 5). With rod, the stainless steel rod of 5 mm diameter is inserted into a 8-mm-diameter hole made in the panel edge. To avoid contact between steel and stone, a plastic sheath is inserted into the hole in the stone (UNE 41957/1-2000 standard 2011).

Concerning the pin anchorages, they are composed of a stainless steel sheet of 2 mm thick and 10 cm wide that is placed into a slot made in 3 mm bottom edges (sustaining) and upper (retention) of the stone. Regarding the joints between panels, the thickness of the open joints cannot exceed 6–7 mm, because the water inlet could be dangerous.

**Fig. 5** Rod and pin anchors



For greater joints, recesses are carved into the edge of the piece. False joints use a piece with greater hardness and thickness.

#### 4 Pathology

Detachment from traditional stone panels, which constitute a whole with the support wall, called monolithic, can occur for two basic reasons: For anchor failure or lack of anchors.

We also have to consider the movements of the support, dimensional variations, and destruction of anchors (Fig. 6).

Sometimes the stone plates are received with mortar backfill as if it were a tiled. Although these cases are not very common, the failure may occur due to lack of anchors. Cases are usually low-rise platings. In the event that the pieces are large, with low roughness on the back and can occur leakage of water with possible freeze or movements of the support, the detachment is virtually assured.

The anchorage failure due to support movements can be:

- (a) Mechanical,
- (b) Transmitted by the structure on which they rest,
- (c) Thermal, due to changes in diurnal and annual temperature.

Flush efforts that can cause breakage of anchors or opening of joints between parts are produced.



Fig. 6 Panel break around the anchor points

The anchorage failure due to the plating dimensional variations is usually cumulative, since the pieces are placed without gasket. It can cause breakage of the anchors of the pieces by the shear stress on the edges. Breakage of the intermediate anchors may occur by tensile when rising the pieces that are pushing together.

The failure due to anchor destruction can occur for the following reasons:

- (a) By breakage, when the anchors are weak because they cannot bear the self-weight and the dilatation of the panels, which makes both effects accumulate and exceed their mechanical ability.
- (b) By corrosion (Fig. 7), when there is a water filtration from the outside or inside, even by interstitial condensation. The appearance of water is aided by the presence of partial covering of plaster, very hygroscopic even when staples are received, a fact too often yet.

Clay particles found in many building stones, when in contact with water, suffer aggregation–disaggregation and swelling–shrinking processes that can cause severe pathology (Gutierrez et al. 2012).

In fact, it is still considered “traditional”, and therefore acceptable, the placement of plating supported by galvanized steel hooks anchored in the edge of the work-piece and positioned while the panels receiving them with plaster and some fiber, in the same way as traditional “monumental masons” of interiors. Moreover, although the Spanish standard indicates that the minimum diameter of the hooks must be five millimeters, the applicators commonly use hooks of 1.6 mm to be easier to bend with the hands. In these cases, the set of errors (galvanized steel, plaster mortar, small diameter, simultaneous placement and subsequent filtration of rainwater) causes corrosion of the hooks is accelerated and reach their depletion.

The plaque rupture can be caused by lack of integrity of the piece when it is too weak (less than 2 cm thickness), when it has some quarry “hairs” or when it is



**Fig. 7** Anchor corrosions

located in low zones (accessible), by bumps and not to have been provided its cladding.

## 5 Preventive Measures

For greater conservation and durability of the panels, we can take the following preventive measures:

To introduce discontinuities in the panel support; To insert expansion joints in the panels surface, in addition to the above, when “bone placed”; Right design of the encounters between planes; To adapt the type of stone for the panel; To define the most suitable type of anchor. To adjust the strength of the anchors.

### 5.1 Discontinuities in Support of the Panels

We can introduce discontinuities in the façade both with the expansion joints of the support structure and retraction joints, in addition to the expansion joints of the structure.

These joints depend on the material that constitutes the enclosure and predictable temperature gradient according to the urban area and orientation, although a general measure is proposed to be a façade joint between two structure joints (about 17 m) for the non-bearing walls of brick or block.

### 5.2 To Introduce Expansion Joints of the Panels

We can introduce expansion joints of the panels, in addition to the above, when is a bone placed (Table 1, Fig. 8).

Such joints may follow a proper modulation to the façade composition and the size of the pieces, and they should be introduced both vertically and horizontally, depending on the coefficient of the stone expansion, climate area and orientation (Monjo and Lamet 1999).

**Table 1** Distance between expansion joints (horizontal and vertical)

Expansion coefficient in mm/m °C by type of stone	Mild climate $\Delta T \sim 40 \text{ }^\circ\text{C}$	Extreme climate $\Delta T \sim 60 \text{ }^\circ\text{C}$
$C = 0.0054$ in limestone and marble	Joint every 15 m	Joint every 10 m
$C = 0.0162$ in granite and slate	Joint every 6 m	Joint every 4 m
$C = 0.022$ in sandstones	Joint every 4 m	Joint every 3 m

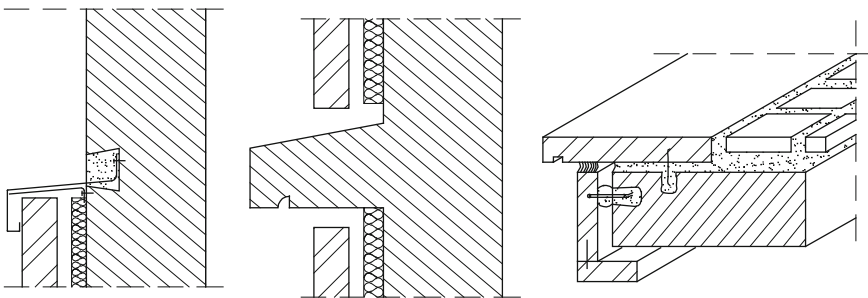


**Fig. 8** Joints between the pieces

The joints may be performed in different ways, always ensuring the free mobility of the panels. In the case of vented panels, with all open connections, these expansion joints are not necessary.

### 5.3 *Right Design of the Encounters*

Right design of the encounters between the planes, both horizontally and vertically, ensures the watertight and shock protection, especially in sockets (Fig. 9).



**Fig. 9** Encounter of different surfaces

### 5.4 Adaptation of the Type of Stone Panels

The characteristics of the stone used are conditioned at least by the following factors: coefficient suction/porosity, frost resistance, flexural strength, and pullout resistance.

Factors can be summarized in two types of behavior, against the rain and temperature changes, and to pressure/wind suction.

Compared with the first, we should consider the porous structure of the stone. For monolithic panels, the suction coefficient must not exceed 0.06, seen global recommendation for facade materials, especially in cold climates, unless we secure the no frost resistance of stone.

Only in the case of ventilated panels, we can use stones with higher suction coefficient, so the air chamber prevents water go into the building. Regarding the factors that depend on the pressure/suction wind, its mechanical strength is considered to compression, flexion and pullout mainly.

Mechanical strength is an important factor and here we must differentiate the compression and bending behavior. A compression is used only to limit the use of the stones when the compressive stress arises through the transmission of the weight of other pieces or by expansion of the stone. The first is limited with the fixing and resistance of the anchors and the second, with the indicated expansion joints. Mainly bending behavior is related to the distance between the supports and the panel thickness. We need higher resistance to bending or greater thickness if the panel size increases (Table 2) (Vera 2001).

The lower thickness to 30 mm is recommended only for monolithic panels when the size of the pieces in any direction does not exceed 40 cm, and they are held with at least four pivots.

In any case, we always check that drilling at the edge of the pieces allow sufficient thickness to satisfy the pullout strength shown in Table 2.

Mechanical pullout strength depends on the mechanical characteristics of the stone and its thickness. Table 3 below determines the minimum required resistance to stone depending on the level of exposure and the panel size, assuming four anchors in each panel.

**Table 2** Recommended thickness of the pieces

R, Bending strength by UNE 22.176, in N/mm <sup>2</sup>	Maximum size of the pieces in cm		
	L < 60 cm	60 < L < 100 cm	L > 100 cm
50 > R > 22.5 slates	e = 30 mm	e = 30 mm	e = 30 mm
22.5 > R > 7.5 granite, limestone and marble	e = 30 mm	e = 30/40 mm	e = 40 mm
R < 7.5 sandstones	e = 40/50 mm	e = 60 mm	e = 60 mm

**Table 3** Pullout resistance of the panel ( $V_p$ )

W, Wind exposure level in Km/h	Panel surface in m <sup>2</sup>		
	S < 0.5	0.5 < S < 1.00	S > 1.00
W < 144	$V_p = 0.4$ KN	$V_p = 0.75$ KN	$V_p = 0.75$ KN
W < 176	$V_p = 0.58$ KN	$V_p = 1.15$ KN	$V_p = 1.15$ KN

### 5.5 Definition of the Most Suitable Type of Anchor

All anchors must be able to support its own weight and the stress caused by thermal expansion. In addition, they must be stainless.

We distinguish two basic types: hidden and viewed.

#### Hidden Anchors

Hidden anchors hold the piece by the side edge, with a pivot or by a metal plate. Pivots (4 per panel) are placed both horizontally and vertically, and each anchor shares pivots with two adjacent pieces. They must have a minimum diameter of 5 mm and a length of 30 mm.

Metal plates (4 per plate) are placed on upper and lower sides. They must have a minimum thickness of 3 mm, a width of 30 mm, and a depth of 25 mm.

#### Viewed Anchors

Continuous and longitudinal profiles with T shape hold the edge of the parts in one direction at all joints. This can be either horizontally or vertically (preferably horizontal to support the individual weight of the different pieces).

They can be made of stainless steel or anodized aluminum or lacquered.

### 5.6 Adequate Strength of the Anchors

We must ensure adequate pullout and shear strength of the anchor system to the support. First of all, the shear strength (T) covers the weight of the piece and, secondly, the expansion between joints.

The recommended resistance depends on the size of the piece and its efforts:

- Panels with “L” (maximum dimension) <60 cm, T = 1.50 kN
- Panels with 60 < “L” < 100 cm, T = 2 kN
- Panels with “L” > 100 cm, T > 2 kN

**Table 4** Pullout resistance of the wall anchor (Va)

Surface panels in m <sup>2</sup>	Wind exposure level in Km/h	
	W < 144 km/h	W < 176 km/h
S < 0.5 m <sup>2</sup>	Va = 0.75 KN	Va = 1.15 KN
0.5 < S < 1.00 m <sup>2</sup>	Va = 1.50 KN	Va = 2.25 KN
S > 1.00 m <sup>2</sup>	Va = 1.50 KN	Va = 2.25 KN

Pullout strength of the wall anchor (Va) ensures the stability of the anchor against wind stresses, both pressure and suction (Table 4).

The previous restraint of the anchors must ensure their resistance to hang the stone of them. It requires a very accurate and previous redefinition of the panels to avoid reaching allowable tolerance.

The anchor can be with hydraulic mortar (traditional system). In this case, we will wait sufficiently for the curing and hardening of the mortar. No need to use plaster or gypsum in any case, but we may use accelerators. We can also be used for a quick-use chemistry anchors (resins).

In these cases, we will check the possible changeability of the resin by ultraviolet radiation or by overheating. Finally, we have the “mechanical” anchor (expansion plug) for immediate use. This measure eliminates the option of traditional hooks, which are fixed to the panel simultaneously.

Suitable mechanization of the panel edges for attachment to the hidden anchor. It may be with pivots, i.e., drilling in the center of the edge with a greater diameter than the thickness of the pivot plus 1 mm. Or you may be using metal plates, assuming a cut in the middle of edge whose width is greater than the thickness of the metal plate plus 1 mm.

All anchors must be properly protected against oxidation and corrosion. Preferably, we use stainless steel. Pieces with quarry hairs or damage from handling should be rejected. If we got panels in building baseboards, fixed with cement mortar, we will not use gypsum or plaster, but will employ thicker parts.

## 6 Repair Measures

The stone panels allow reparation without demolish them, even when there are widespread implementation errors. We have several cases, depending on the cause:

- Detachment by dimensional variations of the panels due to temperature changes or humidity. We must introduce expansion joints based on demolishing a row of pieces and replace them. The joints can be any of the types indicated in prevention schemes.
- Detachment due to destruction or lack of anchors. In this case, the pieces must be anchored from the outside by:



- (a) Punctual anchors, by metal bolts (usually two each piece) with mechanical or chemical anchorage system, ensuring their grip to the solid part of the support. These anchors are typically covered on the outside with stonemason mastic.
- (b) Linear anchors, based on metal profiles placed on the outside and anchored at certain points, distributed in such a way that all parts are subjected to two opposite sides.

In the case of the destruction of the anchors due to a leak of water or condensation, you must first stop the cause and then check the status of the other anchors.

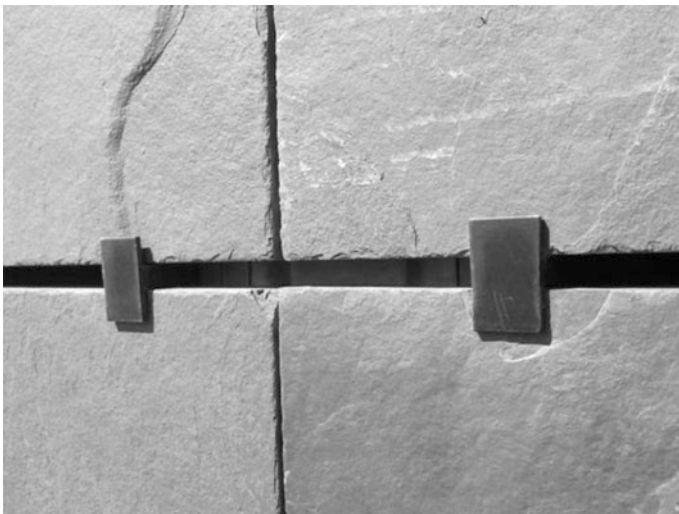
If the water filtration appears through plating joints, from the outside, we can proceed to seal them with suitable elastoplastic materials.

If the anchors are greeted with plaster or if the exterior cladding was applied with this material, it will be advisable to demolish and remake the plates to avoid the continuous moisture absorption by the plaster, thus eliminating a factor of permanent risk.

It may occur a detachment due to support movements. Usually, elastic movements of the structure cause them. Therefore, we must strengthen it to then check the status of the pieces anchorage and, if appropriate, proceed with their punctual or lineal anchor.

In the case of the broken piece by weakness or “quarry hairs”, replacing this piece and anchoring the new with point anchors are recommended.

In Figs. 10 and 11, we can see some examples.



**Fig. 10** Natural stone panels held by viewed fixings



**Fig. 11** Stone panels previously taken with mortar and repaired with screws

## **7 Application of Infrared Thermography in the Pathology Study of Back-Ventilated Façades with Stone Panels**

Appropriate conservation measures for a particular building can only be planned and carried out when a precise diagnosis of the damage has been made, providing sufficient and reliable information on the materials present, as well as on the factors, processes and state of deterioration (Fitzner 1996).

We must use great caution when taking action on a building and so non-destructive techniques, such as infrared thermography, facilitate the study and further the understanding of materials and construction processes, without need to inflict damage on the building.

Most buildings have been built with different types of stones. Underlying this diversity are architectural, constructive or artistic considerations, the proximity of quarries, and the ease of extraction from them, and so forth.

### **7.1 Theoretical Basis of Thermography**

Many other previous studies have already established a link between infrared thermography and the detection of defects in stone materials of a building (Lerma 2012) or in a laboratory (De Freitas et al. 2014), although in these studies the thermographic data for different points of the walls are interpreted by means of graphs (Danese et al. 2010). Those areas where thermal discontinuities occur are usually where defects in the material are located. On the other hand, those points that display a similar temperature demonstrate thermal inertia, i.e., the tendency of a particular element to resist thermal changes, and this depends on the characteristics of the material, the moisture present, and any damage (Campbell 1996).

Thermography has also been used to detect moist areas using multitemporal analysis (Lerma et al. 2011).

The thermal pattern of a material largely depends on its characteristics (thermal diffusion, porosity, density, etc.). The possibility of being able to clearly visualize the defects of a particular material depends on the difference between the thermal characteristics of the material and the absence of homogeneity (Meola et al. 2011).

The emissivity values of the most common construction materials are over 90 %, and in our study, we have taken 0.95 as the default value, and so we believe that the results obtained from the thermographic measurements are reliable (Rodríguez Liñán 2011). Moreover, emissivity is practically constant for non-metallic materials (Cañas 2005).

### 7.2 Introducing the Building Under Analysis

The building we have used to collect data on site is the Tourism building of Valencia (Spain). This building has exterior facades with stone panels.

Shortly after it built, many of these panels had defects (cracks usually), as shown in Fig. 12.

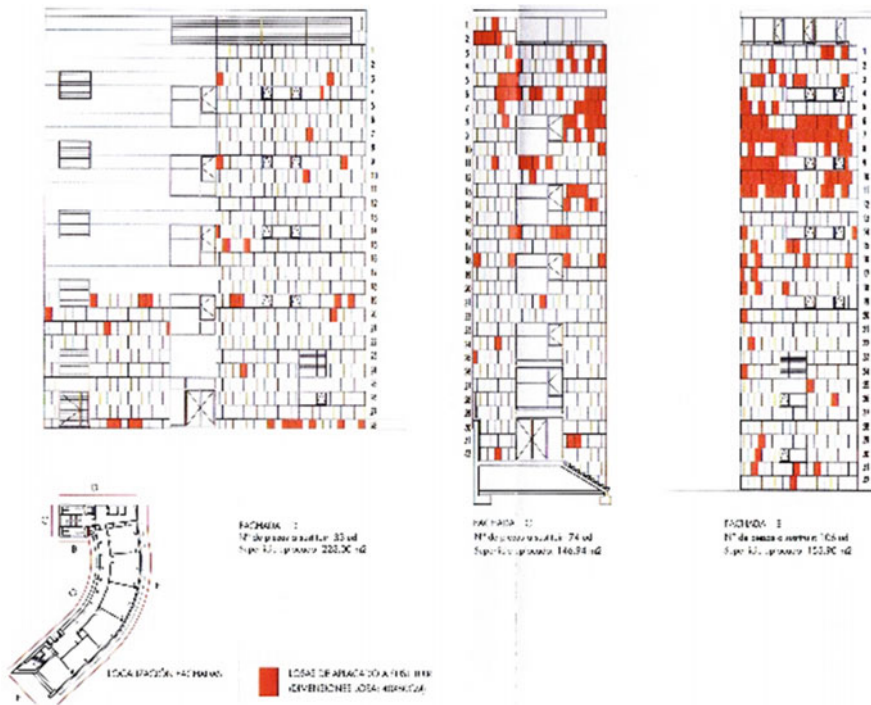
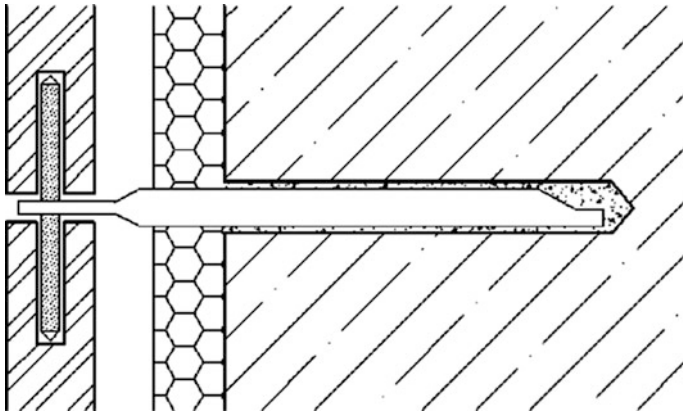
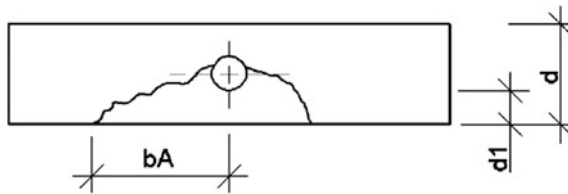


Fig. 12 Elevations and plant of Tourism Building of Valencia (Spain)



**Fig. 13** Stone panels anchorage system. UNE 22203-2011 standard

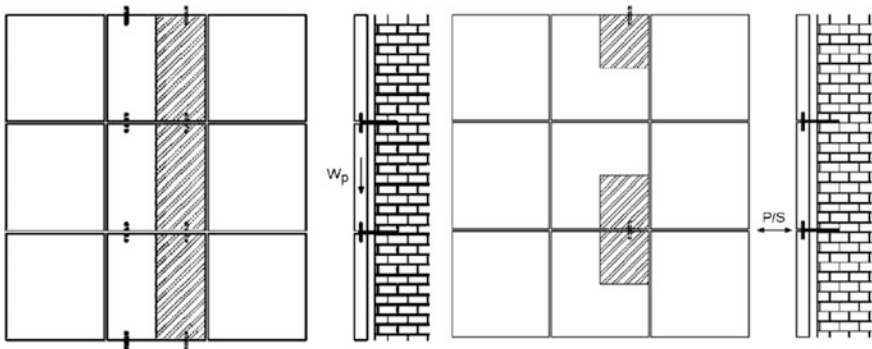


**Fig. 14** Common break in stone panels. UNE 22203-2011 standard

In Fig. 13, we can observe the anchoring system used in this building (UNE 22203-2011 standard 2000). It is a system that supports the gravitational load from the bottom of the panel and prevents occasional loss of the pieces in its top. These anchors are made of metal and they should be inserted in a plastic sheath that is introduced into a hole made in the stone panel.

In Fig. 14, the usual stone panel break is shown.

Figure 15 shows the distribution of loads in the horizontal joint of the stone pieces. With this configuration, four support anchors, two on the top and two at the



**Fig. 15** Distribution of the loads in the horizontal joint panels. UNE 22203-2011 standard

bottom, fasten each panel. Each anchor supports half of the panel weight plus half of the pressure/suction wind load.

### 7.3 Methodology

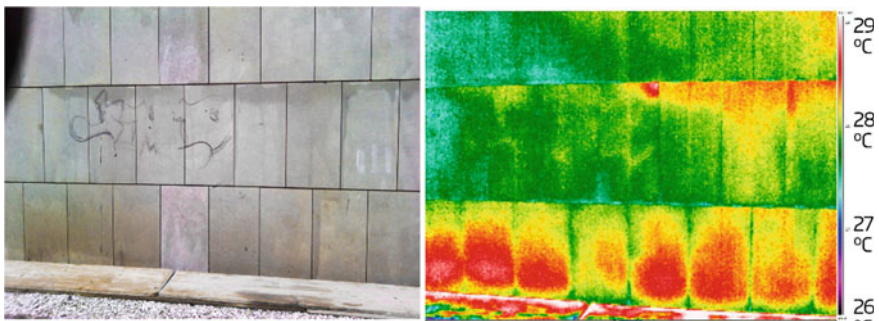
We have observed that in the Tourism building in Valencia, a large number of panels were broken at the junction between the anchor and the stone, as Fig. 3 shows. The main of this research is to demonstrate that it is possible to visualize with a thermographic camera the stone breaking around the anchor before it falls off. Other defects, such as poor application of water repellents, have been observed also.

In this study, we used a FLIR B335 camera that produces thermographic images at a resolution of  $320 \times 240$  pixels, with a temperature range of  $-20$  to  $+120$  °C and an accuracy of less than 50 mK NETD. The thermographic images were subsequently processed with FLIR QuickReport software, which can vary the color palette, temperature range, distance, as well as calculate the maximum, minimum, and average temperatures in the study areas. The temperature of each pixel in the image can be exported in Excel format.

### 7.4 Results of the Analysis

Thermal response of panels, in a part of them or as a whole, gives us a lot of information.

Different fastening panels can be observed as shown in Fig. 16. The lower parts of the panels are taken with mortar to prevent landslides and the rest of them with metal anchors.



**Fig. 16** Panels thermal response of the bottom of the façade

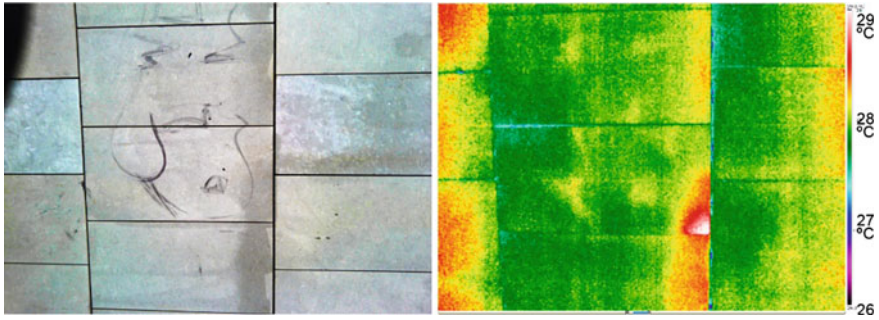


Fig. 17 Overview of the panels with defect in a corner

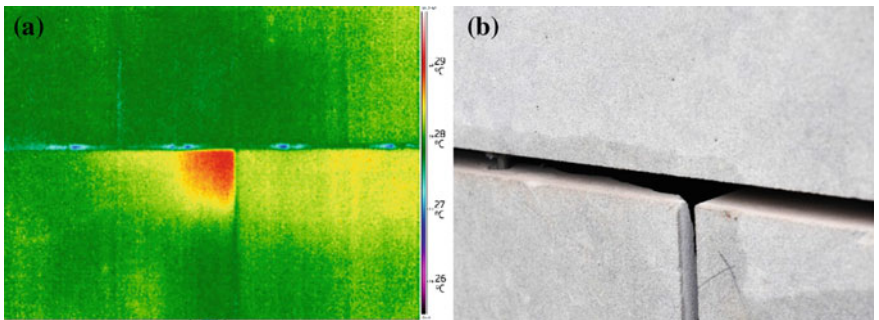
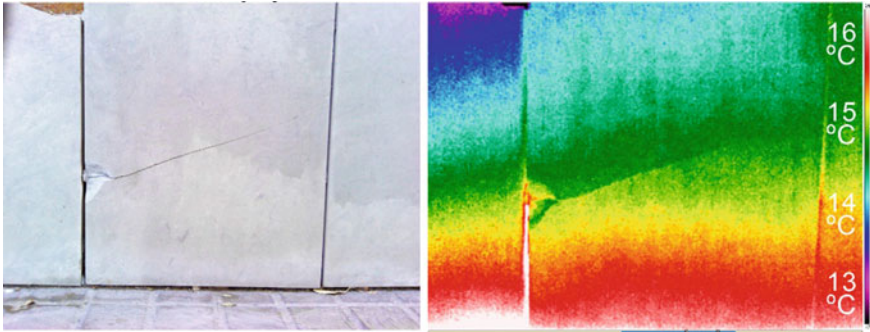


Fig. 18 The corner of this panel has less thickness than the rest

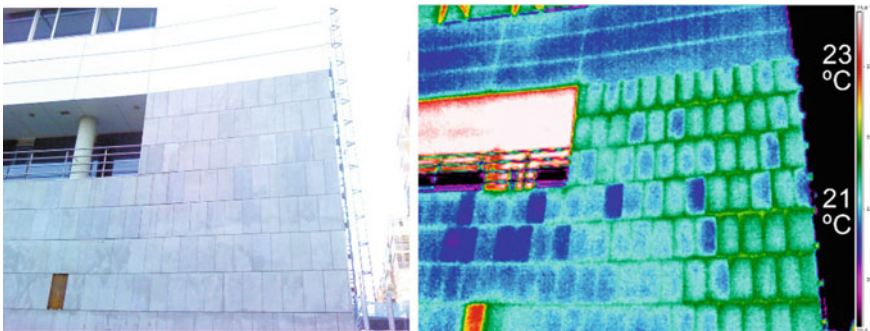
Figures 17 and 18 show defects or cracks in corners. Although in a real picture we cannot observe any breakage or defect or reduced thickness in some areas of the panels (Fig. 18a), in the infrared image they are clearly marked with a different temperature. Specifically, if the slab has less thickness, thermal inertia is lower and that piece is heated or cooled faster. Therefore, thermal response will be different from the rest of the panel (Fig. 18b).

The temperature change that occurs in Fig. 19 shows the trajectory and longitude of the crack. In real picture, we can see a small part of the crack only, but with the thermographic camera, we can check whether that break is higher.

In this building, a water-repellent treatment on its surfaces was also applied to the panels to prevent a large amount of absorbed water and the deterioration of the stone. The application was not very successful, and we can be clearly seen the thermal response of each panel in Fig. 20. This technique can be used for testing on this type of a surface treatment of construction materials.



**Fig. 19** Break from the anchor on a stone panel

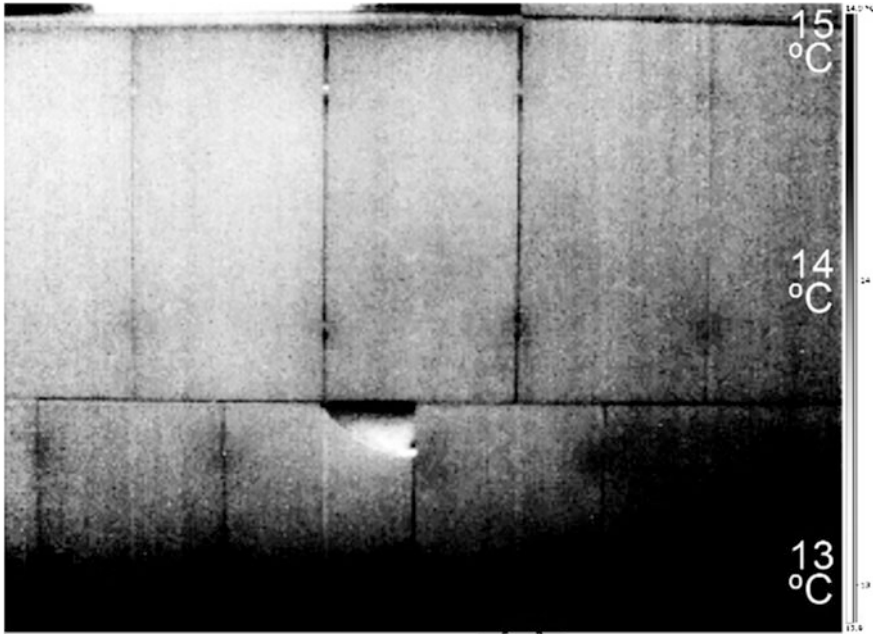


**Fig. 20** Water-repellent surface treatment. Real and thermal pictures

Anchor break processes can also be detected before the definitive break occurs and the stone falls off. Figure 21 shows an area around each stone anchors at different temperature. That is just the area will fall of later (Fig. 14).

Immediate and obvious, results, always, are not obtained using the thermographic camera. It is very important to maintain the environmental conditions (sunlight, temperature, humidity, etc.).

Thermal technology can be very useful repairing buildings, especially when we diagnose the pathology they have. One of the great advantages is that you can get data from remote areas without preparing scaffolds, stairs, etc. The figures shown in this article demonstrate that cracks can be observed even before the falling stone parts and they can be seen with naked eye.



**Fig. 21** Area around the anchors at different temperatures

**Acknowledgment** The authors thank Javier Pérez Igualada for the building plans shown in Fig. 12.

## References

- Campbell JB (1996) Introduction to remote sensing, 2nd edn. Taylor & Francis, London
- Cañas I (2005) Thermal-physical aspects of materials used for the construction or rural buildings in Soria (Spain). *Constr Build Mater* 19:197–211
- CTE Spanish standard, Código Técnico de la Edificación. Specific documents: Energy saving (2013). Salubrity (2009). Security in case of fire (2014). Security Use (2010)
- Danese M, Demsar U, Masini N, Charlton M (2010) Investigating material decay of historic buildings using visual analytics with multi-temporal infrared thermographic data. *Archaeometry* 52(3):482–501
- De Freitas SS, De Freitas VP, Barreira E (2014) Detection of façade plaster detachments using infrared thermography—A nondestructive technique. *Constr Build Mater* 70:80–87
- Fitzner B (1996) en VV AA Técnicas de diagnóstico aplicadas a la conservación de los materiales de construcción en los edificios históricos. Junta de Andalucía, Sevilla
- Gutiérrez J, Mas Á, Gil E, Galvañ V (2012) Clay-related damage in rainscreen walls built with natural stone coverings. *Constr Build Mater* 357–367
- Lerma C (2012) Análisis arquitectónico y constructivo del Real Colegio de Corpus Christi de Valencia. Ph.D. Thesis. Universitat Politècnica de València, Valencia
- Lerma JL, Cabrelles M, Portalés C (2011) Multitemporal thermal analysis to detect moisture on a building façade. *Constr Build Mater* 25:2190–2197



- Mas Á, Gutiérrez J, Gil E, Gil A, Galvañ V (2010) Design and construction recommendations to improve impermeability in rainscreen walls built with natural stone coverings. *Constr Build Mater* 160–170
- Meola C, Carlomagno GM, Giorleo L The use of infrared thermography for materials characterization. *J Mater Proc Technol* 155–156:1132–1137
- Monjo J, Lamet B (1999) Aplacados pétreos (chapados). Ficha técnica Asemas. RVC 501
- Quintás C (1996) Cerramientos pesados. *Tectónica, II, Envoltentes*
- Rodríguez Liñán C (2011) Inspección mediante técnicas no destructivas de un edificio histórico: Oratorio San Felipe Neri (Cádiz). *Inform Constru* 63:13–22
- UNE 22203-2011 standard (2011). Natural stone products. Construction of slabs for façade with natural stone. AENOR, Madrid
- UNE 41957/1-2000 standard (2000). Anchors for buildings facades claddings. Part 1: Subsystems for lightweight claddings. AENOR, Madrid
- Vera R (2001) Fachadas trasventiladas con revestimientos pétreos. Asemas technical file. RVC 5