

# Roger Marjoribanks



# Geological Methods in Mineral Exploration and Mining

Roger Marjoribanks

# Geological Methods in Mineral Exploration and Mining

Second Edition

 Springer

Roger Marjoribanks  
27A Axford Street  
Perth WA 6152  
Australia  
marjex@ozemail.com.au

ISBN 978-3-540-74370-5 e-ISBN 978-3-540-74375-0  
DOI 10.1007/978-3-540-74375-0  
Springer Heidelberg Dordrecht London New York

Library of Congress Control Number: 2010926490

© Springer-Verlag Berlin Heidelberg 1997, 2010

This work is subject to copyright. All rights are reserved, whether the whole or part of the material is concerned, specifically the rights of translation, reprinting, reuse of illustrations, recitation, broadcasting, reproduction on microfilm or in any other way, and storage in data banks. Duplication of this publication or parts thereof is permitted only under the provisions of the German Copyright Law of September 9, 1965, in its current version, and permission for use must always be obtained from Springer. Violations are liable to prosecution under the German Copyright Law.

The use of general descriptive names, registered names, trademarks, etc. in this publication does not imply, even in the absence of a specific statement, that such names are exempt from the relevant protective laws and regulations and therefore free for general use.

Printed on acid-free paper

Springer is part of Springer Science+Business Media ([www.springer.com](http://www.springer.com))



# Preface

This book is written as a practical field manual to be used by geologists engaged in mineral exploration. It is also hoped that it will serve as a text and reference for students in Applied Geology courses of universities and colleges. The book aims to outline some of the practical skills that turn the graduate geologist into an explorationist. It is intended as a practical “how to” book, rather than as a text on geological or ore deposit theory.

An explorationist<sup>1</sup> is a professional, usually a geologist, who searches for ore bodies in a scientific and structured way. Mineral exploration professionals include a range of people: business people involved in financial and entrepreneurial activities in the mining industry, board members and company management no longer involved in day to day exploration but often with past hands-on experience, technical assistants, tenement managers, environmental and safety personnel, drillers, surveyors, IT specialists, geophysicists and geochemists, ore reserve specialists, various types of consultants, and the exploration geologists. Typically the exploration geologists are the jacks-of-all-trades with an overview of the team and the project. Although explorationist is a somewhat awkward and artificial term, this is the only available word to describe the totality of the skills that are needed to locate and define economic mineralization. Even the mine geologist, attempting to define ore blocks ahead of the mining crews, is an explorationist. The most fundamental and cost-effective skills of the explorationist relate to the acquisition, recording and presentation of geological knowledge so that it can be used to predict the presence of ore – these are the skills that are the subject of this book.

Practical field techniques taught at undergraduate level are often forgotten and sometimes, although taught, are not reinforced by subsequent practice; some skills that the explorationist needs may never be adequately taught in the academic environment of universities. Special techniques and skills – or example, identifying prospective ground for acquisition, detailed prospect mapping or logging drill core

---

<sup>1</sup> Throughout the book, the rules of English grammar compel me, from time to time, to ascribe a sex to my protagonist. In the first edition I got around this by using the expression “he or she”; but this now seems to me an awkward circumlocution. In this edition I simply ascribe gender alternately.

or cuttings – seldom figure in basic training courses. Although no book can substitute for hands-on experience and demonstration, this manual aims to address some of these deficiencies.

The book does not offer a set of standard rules that must be invariably followed. It describes practical skills and techniques that, through the experience of many geologists, have been found to be effective. However, it is not the author's intention to be prescriptive; each geologist has to develop their own techniques and will ultimately be judged on results, not the process by which these results were reached. In mineral exploration, the only "right" way of doing anything is the way that locates ore in the quickest and most cost-effective manner. It is preferable, however, for an individual to develop their own method of operation after having tried, and become aware of, those procedures that experience has shown to work well and which are generally accepted in industry as good exploration practice.

New ideas and techniques are constantly emerging and no book such as this can be regarded as being a final statement. To make this a useful document and to keep it up to date and relevant, geologists should use it critically.

The chapters of the book approximately follow the steps that a typical exploration programme would go through. In Chap. 1, the generation of new projects and prospects and the nature of the exploration process are described. In Chaps. 2 and 3 are descriptions of the various techniques employed in making geological maps from remote sensed reflectance imagery, surface outcrop and mine openings. Chapter 4 covers techniques employed by the explorationist to create new rock exposure – trenching, pitting, stripping and underground development. Chapters 5, 6 and 7 (supported by several Appendices) cover all aspects of drilling. These chapters constitute a major part of this book, reflecting the supreme importance of drilling to the explorationist. In Chap. 8 is a detailed description of the remote sensed images provided by Land observation satellites – a modern day boon to explorationists. Although this book is primarily concerned with geological methods, in Chap. 9 a brief overview is given of the more commonly used techniques of exploration geophysics and geochemistry. Finally, Chap. 10 discusses digital exploration data bases and outlines the use of geographical information systems (GIS) and exploration software for the storage, manipulation and presentation of digital exploration and mining data.

This second edition has been greatly expanded from the original 1997 edition to reflect changes that have taken place in exploration methods over last 10 years. Basic geological field techniques still constitute the core skill for the explorationist and are the subject of a significant part of the book. However new technological advances have expanded the range of tools available to her. In diamond drilling, faster and more reliable systems for orienting core have made this procedure almost routine and have led to an increased awareness on the value to be got from quantitative structural logging. Satellite navigation systems have become much more accurate thus expanding the role that GPS can play in providing survey controls for detailed geological mapping, and the collection of geochemical and geophysical data. New, very high resolution, commercial land observation satellites increasingly offer imagery that rival the best of air photography both in resolution and price.

The desk top and laptop computers of today offer an almost exponential increase in processing power, memory capacity and graphics ability which, combined with new powerful software packages and sophisticated instrumentation, have revolutionised traditional geophysical and geochemical techniques.

New software programs available today allow vast amounts of data to be processed and analysed, and this leads to a tendency for the present day explorationist to spend more time in front of a monitor than in the field. Digital data, massaged and presented as multi colour 3-D surfaces can acquire a life of its own, quite divorced from the reality it is supposed to represent. There is an increasing danger that by focussing on data handling the explorationist loses sight of the need for quality data acquisition. The underlying philosophy behind much of this book is that, if geological data is to be of value in finding ore bodies, ideas and insights must be used in a structured way to control all stages of data handling from field collection through to final presentation. In these days of electronic storage and processing of mass data, it is worth remembering the well-known quote<sup>2</sup>:

Data is not information  
Information is not knowledge  
Knowledge is not understanding  
Understanding is not wisdom

The book outlines some geological techniques for acquiring knowledge. The rest is up to the reader.

---

<sup>2</sup> Anonymous, but almost certainly adapted from: "Where is the wisdom we have lost in knowledge? Where is the knowledge we have lost in information" (T.S. Eliot)

# Acknowledgments

I am indebted to the many skilled field geologists with whom I have been privileged to work over the years and from whom I have acquired many of the exploration and geological ideas, techniques and procedures that are described here. Among these are: Ray Crawford, Neville George, Don Bowes, Frank Hughes, Dave McKenzie, Don Berkman, Mike Rickard, Ilmars Gemuts, Doug Dunnet, John Thoms, Dick Sillitoe and Gary Arnold.

The Australian Institute of Geoscientists kindly gave their permission to reproduce a number of diagrams that previously appeared in *AIG Handbook 5 – Structural logging of drill core* – that I authored in 2001 (2nd Edition 2007). The diagrams in question are 6.1, 6.6, 6.9, 6.10, 6.14, B.5, B.7, B.13, C.1, C.2 and C.3. The permission of Ivanhoe Mining Limited and Newcrest Limited is acknowledged to publish the descriptions of some of their exploration projects that appear at the end of Chap. 4.

Geological maps and sections appearing in the book are based on actual projects that the author has worked on. They have been re-drafted, modified and re-named to make them suitable for this publication and to preserve their anonymity.

Gary Arnold kindly undertook to read a draft of the text and the book has benefited greatly from his many constructive comments. His input particularly into Sect. 9.2 (magnetic surveys) and Sect. 10.3 (GIS and digital databases) is gratefully acknowledged.

Needless to say, I accept full responsibility for all biases and errors that might still remain in this work.

# Contents

<b>1</b>	<b>Prospecting and the Exploration Process</b>	1
1.1	Definition of Terms	1
1.2	Generating New Projects and Prospects	1
1.3	Some Ways of Generating New Exploration Ideas	3
1.4	A Check-List of Negative Assumptions	4
1.5	Stages in Prospect Exploration	5
1.5.1	Target Generation	5
1.5.2	Target Drilling	6
1.5.3	Resource Evaluation Drilling	6
1.5.4	Feasibility Study	6
1.6	Maximizing Success in Exploration Programmes	7
1.7	Different Types of Exploration Strategy	9
1.8	Exploration Feedbacks	9
1.9	Breaking Occam's Razor	10
	References	11
<b>2</b>	<b>Geological Mapping in Exploration</b>	13
2.1	General Considerations	13
2.1.1	Why Make a Map?	13
2.1.2	The Nature of a Geological Map	14
2.1.3	Intelligent Mapping	15
2.1.4	Choosing the Best Technique	18
2.1.5	Choosing the Best Scale	20
2.1.6	Measuring and Recording Structures	22
2.1.7	Using Satellite Navigation (GPS)	23
2.2	Mapping Using Reflectance Imagery as a Map Base	25
2.2.1	General	25
2.2.2	Acquiring Air Photographs	26
2.2.3	Geological Interpretation	26
2.2.4	Determining Scale	27
2.2.5	Stereoscopic Image Pairs	29
2.2.6	Image Handling Techniques	31
2.2.7	Working with Enlarged Air Photographs	34

- 2.2.8 Data Transfer to Base Map . . . . . 37
- 2.3 Mapping with a Plane Table . . . . . 38
- 2.4 Mapping on a Pegged Grid . . . . . 41
  - 2.4.1 Requirements of the Grid . . . . . 41
  - 2.4.2 Making the Map . . . . . 43
- 2.5 Mapping with Tape and Compass . . . . . 47
- References . . . . . 49
- 3 Mine Mapping . . . . . 51**
  - 3.1 General . . . . . 51
  - 3.2 Mapping in Open Cuts . . . . . 51
  - 3.3 Mapping Underground Openings . . . . . 56
  - 3.4 Safety in Mines . . . . . 60
  - References . . . . . 61
- 4 Trenching and Underground Development . . . . . 63**
  - 4.1 Preamble . . . . . 63
  - 4.2 Pitting and Trenching . . . . . 63
  - 4.3 Underground Development . . . . . 64
  - 4.4 Safety and Logistics in Trenching . . . . . 65
  - 4.5 Geological Mapping . . . . . 66
  - 4.6 Geochemical Sampling . . . . . 69
  - 4.7 Examples of Successful Exploration Programmes . . . . . 71
  - References . . . . . 72
- 5 Drilling: A General Discussion the Importance of Drilling . . . . . 75**
  - 5.1 Types of Drilling . . . . . 75
  - 5.2 Choosing the Right Technique . . . . . 76
  - 5.3 Targeting Holes . . . . . 79
  - 5.4 Drilling on Section . . . . . 83
  - References . . . . . 84
- 6 Rotary Percussion and Auger Drilling . . . . . 85**
  - 6.1 Rotary Percussion Drilling . . . . . 85
    - 6.1.1 Reverse Circulation Drilling (RC) . . . . . 85
    - 6.1.2 Air Core Drilling . . . . . 93
    - 6.1.3 Rotary Air Blast (RAB) Drilling . . . . . 93
  - 6.2 Auger Drilling . . . . . 96
  - References . . . . . 97
- 7 Diamond Drilling . . . . . 99**
  - 7.1 Preamble . . . . . 99
  - 7.2 Some Definitions . . . . . 100
  - 7.3 Before You Begin . . . . . 102
  - 7.4 Setting Up a Diamond Hole . . . . . 102
  - 7.5 Geological Observation . . . . . 103
  - 7.6 Recognizing and Interpreting Structures in Core . . . . . 104

- 7.6.1 Statement of the Problem . . . . . 104
- 7.6.2 Planar Structures . . . . . 104
- 7.6.3 Faults . . . . . 105
- 7.6.4 Linear Structures . . . . . 107
- 7.6.5 Folds . . . . . 109
- 7.6.6 The Scale Problem . . . . . 110
- 7.6.7 Vergence . . . . . 112
- 7.7 Measuring and Recording Structures in Core . . . . . 113
- 7.8 Core Logging Systems . . . . . 116
  - 7.8.1 Prose Logging . . . . . 116
  - 7.8.2 Graphical Scale Logging . . . . . 117
  - 7.8.3 Analytical Spreadsheet Logging . . . . . 119
- 7.9 Down-Hole Surveying . . . . . 123
  - 7.9.1 Procedure . . . . . 123
  - 7.9.2 Using Down-Hole Survey Data to Plot Sections  
and Plans . . . . . 124
- 7.10 When Should Core Be Oriented? . . . . . 127
- 7.11 Sampling and Assaying . . . . . 127
- 7.12 Core Handling . . . . . 130
- 7.13 Core Photography . . . . . 135
- References . . . . . 136
- 8 Satellite Imagery . . . . . 137**
  - 8.1 General Discussion . . . . . 137
  - 8.2 How Earth Observation Satellites Work . . . . . 139
  - 8.3 Display of Satellite Images . . . . . 140
  - 8.4 Geological Interpretation . . . . . 140
  - 8.5 Analysis of Reflectance Data . . . . . 142
  - References . . . . . 142
- 9 Geophysical and Geochemical Methods . . . . . 143**
  - 9.1 General Discussion . . . . . 143
  - 9.2 Magnetic Surveys . . . . . 146
  - 9.3 Gravity Surveys . . . . . 149
  - 9.4 Radiometric Surveys . . . . . 150
  - 9.5 Electromagnetic (EM) Surveys . . . . . 150
  - 9.6 Electrical Surveys . . . . . 151
  - 9.7 Hybrid Electrical and Magnetic Surveys . . . . . 152
  - 9.8 Advances in Instrumentation and Data Modelling . . . . . 153
  - 9.9 Stream Sediment Sampling . . . . . 155
  - 9.10 Soil Sampling . . . . . 157
  - 9.11 Heavy Mineral Concentrate (HMC) Sampling . . . . . 158
  - 9.12 Rock Chip Sampling . . . . . 160
  - 9.13 Laterite Sampling . . . . . 161
  - References . . . . . 162

**10 Geographical Information Systems and Exploration Databases . . . 165**

- 10.1 Definition . . . . . 165
- 10.2 The Need for Digital Exploration Databases . . . . . 165
- 10.3 GIS Storage of Map Data . . . . . 168
  - 10.3.1 Digitised Line Format . . . . . 168
  - 10.3.2 Polygon or Vector Format . . . . . 170
  - 10.3.3 Raster Format . . . . . 170
- 10.4 Validation . . . . . 170
- 10.5 Georeferencing . . . . . 171
  - 10.5.1 Geographical Coordinates . . . . . 171
  - 10.5.2 Cartesian Coordinates . . . . . 171
  - 10.5.3 Map Datums . . . . . 172
  - 10.5.4 Map Registering . . . . . 173
- 10.6 Manipulation of GIS Data . . . . . 173
- 10.7 Presentation of GIS Data . . . . . 174

**Appendix A**

**Notes on the Use of Graphical Scale Logging . . . . . 179**

- A.1 Column 1 (Hole Depth) . . . . . 180
- A.2 Column 2 (Core Recovery) . . . . . 180
- A.3 Column 3 (Core Quality) . . . . . 180
- A.4 Column 4 (Sample No.) . . . . . 180
- A.5 Column 5 (Assay Results) . . . . . 180
- A.6 Column 6 (Mapping Logs) . . . . . 180
- A.7 Column 7 (Histogram Logs) . . . . . 181
- A.8 Column 8 (Geology Notes) . . . . . 182
- A.9 Column 9 (Summary Log) . . . . . 182
- A.10 Remarks Area . . . . . 182

**Appendix B**

**Oriented Drill Core: Techniques and Procedures . . . . . 183**

- B.1 Techniques for Orienting Drill Core . . . . . 183
  - B.1.1 Non-mechanical Means . . . . . 183
  - B.1.2 Mechanical Means . . . . . 183
- B.2 How to Handle Oriented Core . . . . . 188
- B.3 How to Measure Structures in Oriented Core . . . . . 190
  - B.3.1 Before You Measure . . . . . 190
  - B.3.2 How Many Measurements Are Needed? . . . . . 191
  - B.3.3 Using a Core Frame . . . . . 192
  - B.3.4 Using Internal Core Angles . . . . . 195
  - B.3.5 Discussion on the Best Measuring Technique . . . . . 201
  - B.3.6 Plotting Structure Measurements on Drill Section . . . . . 202

**Appendix C**

**Calculating Strike and Dip from Multiple Diamond Drill Holes . . . 205**

- C.1 The Three Point Problem . . . . . 205



- C.2 Solution Using Structure Contours . . . . . 205
- C.3 Solution Using a Stereonet . . . . . 206
- C.4 An Elegant Solution to Determining the Attitude of  
Planes in Non-oriented Core . . . . . 208
  
- Appendix D**
  - How to Use a Stereo Net to Convert Internal Core Angles  
to Geographic Coordinates . . . . . 211**
  - D.1 The Solution for Planar Structures . . . . . 211
  - D.2 The Solution for Linear Structures . . . . . 213
  
- Appendix E**
  - Practical Field Techniques . . . . . 215**
  - E.1 Choosing the Right Compass . . . . . 215
  - E.2 Understanding Your Compass . . . . . 215
  - E.3 Measuring the Strike and Dip of Planes . . . . . 217
  - E.4 Measuring the Trend and Plunge of Lineations . . . . . 218
  
- Appendix F**
  - Suggested Further Reading . . . . . 223**
  
- Acronyms and Abbreviations . . . . . 229**
  
- Index . . . . . 233**

# Chapter 1

## Prospecting and the Exploration Process

This chapter attempts to put the detailed exploration procedures outlined in this book into the wider context of the whole exploration process from first concept to ore discovery.

### 1.1 Definition of Terms

Exploration field activities take place as part of a strategy (often called a “play”) to locate and define a particular economically mineable mineral commodity (ore) in a mineral province. Large exploration plays are often broken down into individual projects (often a particular tenement<sup>1</sup> group) and each project may contain one or more prospects.

A prospect is a restricted volume of ground that is considered to have the possibility of directly hosting an ore body and is usually a named geographical location. The prospect could be outcropping mineralization, an old mine, an area selected on the basis of some geological idea, or perhaps some anomalous feature of the environment (usually a geophysical or geochemical measurement) that can be interpreted as having a close spatial link with ore. Prospects are the basic units with which explorationists work. The explorationist’s job is to generate new prospects and then to explore them in order to locate and define any ore body that might lie within them.

### 1.2 Generating New Projects and Prospects

Generating new prospects is the critical first stage in the exploration process and is known as prospecting. Traditionally, prospecting was the search for simple visual surface indications of mineralization. Nowadays the range of surface indications

---

<sup>1</sup>The legal title to explore and mine an area goes by different names in different countries and carries a wide variety of rights and obligations. The word “tenement” is used in this book in a non-specific way to refer to all such titles.

that can be recognized by the explorationist is expanded by the use of sophisticated geophysical and geochemical techniques. However, the skills and abilities involved in successful prospecting are common to all techniques. They involve activity, observation, knowledge, insight, opportunism, persistence, lateral thinking and luck. A description of traditional prospecting skills will therefore serve to illustrate these key attributes of success.

During the nineteenth century, in places like Australia or North America, it was still possible to stumble on a kilometres-long prominent ridge of secondary lead and zinc minerals, or a district where ubiquitous green secondary copper minerals indicated the huge porphyry system beneath. Even as late as the second half of the twentieth century, prominent and extensive mineralized outcrop were still being identified in the more remote parts of the world. Discoveries such as Red Dog in Alaska (Kelley and Jennings, 2004; Koehler and Tikkanen, 1991), Porgera in Papua New Guinea (Handley and Henry, 1990) and Ertsberg in West Irian (Van Leeuwen, 1994), belong to this era. Few places are left in the world today which offer such readily identified prizes. For that reason, exploration is increasingly focused on the search for ore bodies that have either subtle outcrop or no outcrop at all.

In spite of this, experience shows that simple prospecting methods can still find ore bodies. Good examples of this are the 1964 discovery of the West Australia nickel sulphide deposits at Kambalda (Gresham, 1991); the 1982 discovery of the massive Ladolam Gold Deposit of Lihir Island, Papua New Guinea (Moyle et al., 1990), the 1993 discovery of the outcropping gossans which overlay the rich Voisey Bay Cu/Ni/Co massive sulphide ore body in Labrador, Canada (Kerr and Ryan, 2000), the discovery in 1996 of the massive Oyu Tolgoi Cu/Au porphyry in Mongolia (Perello et al., 2001) and the discovery of the large Sukari gold deposit in the eastern desert of Egypt<sup>2</sup> (Helmy et al., 2004).

If recent mineral discoveries are examined, it seems that success has come from three main factors:

1. The explorer searched where no one had searched before. This may be because historical or political opportunity made an area accessible that previously was inaccessible. However, very often the reason for the discovery was simply that no one had previously thought to look in that particular place.
2. The explorer identified and tested subtle or non-typical indications of mineralization that had previously been overlooked, either because they were very small or, more usually, because he recognized as significant some feature that previous observers had seen but dismissed as unimportant. As Dick Sillitoe<sup>3</sup> has recently written (Sillitoe, 2004):

---

<sup>2</sup>Oyu Tolgoi and Sukari were both areas of minor known mineralisation and artisanal mining going back thousands of years. However, their true size was not suspected until modern exploration was undertaken.

<sup>3</sup>Richard Sillitoe is a well known international economic geology consultant.

Careful scrutiny of bedrock outcrops, some perhaps only meters across, is a key part of successful exploration—because it may reveal the subtle distal signatures of concealed mineralisation. Recent experience shows, however, that such detailed traversing, even of the most highly explored terranes, by experienced practitioners can also pinpoint partly outcropping deposits which have simply gone undiscovered because the subtle surface expressions are both invisible from the air and on satellite imagery. The oft quoted notion that all wholly or partly exposed deposits have been found in the world’s mature belts is, to my mind, a myth.

3. In areas of known mineralisation (“brownfield” exploration), the explorer employed step-out holes to locate non-outcropping (“blind”) mineralisation below cover. This type of exploration can only be successful where geological knowledge gained from the established mines and prospects gives the explorer confidence to embark on extensive (and expensive) drilling programs in areas that lack outstanding surface indications. Examples of successes from this type of exploration are the discovery by Newcrest at Cadia, NSW, Australia of the Ridgeway porphyry Cu/Au deposit below 450 m of overlying sediment (Holiday et al., 1999) and the 2009 discovery of Merlin Cu/Mo/Au prospect by Ivanhoe Australia Ltd.<sup>4</sup>

One of the most important ingredients of prospecting success has been lateral thinking. By this is meant the ability to:

- see familiar rocks in new contexts
- question all assumptions (but especially one’s own<sup>5</sup>) and accepted wisdom
- be alert for small anomalies or aberrations
- know when to follow a hunch<sup>6</sup> (since some of the above attributes are as much subconscious as conscious).

### 1.3 Some Ways of Generating New Exploration Ideas

New ideas may come “out of the blue”, but more often are the result of certain well-recognized situations that the explorationist is able to combine fruitfully with knowledge that they already have. It pays him to be alert for these situations so as to take advantage of the opportunities that they offer. Here are some of them:

---

<sup>4</sup>In 2009, Ivanhoe Australia announced discovery of a significant new Mo/Rh/Cu deposit (called Merlin) in the Mt Isa Inlier, Queensland, Australia. The discovery was the result of persistence and a commitment to step-out drilling around known mineralisation in one of Australia’s most explored Cu/Au provinces. A preliminary paper on Merlin by Florinio Lazo and Tamal Lal can be found at [www.smedg.org.au](http://www.smedg.org.au) (Accessed Dec 2009).

<sup>5</sup>As the famous twentieth century physicist Richard Feynman said: “The first principle is that you must not fool yourself – and you are the easiest person to fool.”

<sup>6</sup>A current theory is that intuitive and often subconscious processes take place in the right side of the brain, while rational, deductive reasoning derives from the left side. Both processes play a part in successful ore finding.

*Scenario 1:* New knowledge of the geology or geophysics of an area becomes available from new mapping (either your own or Geological Survey maps). Combined with your own understanding of mineralization, the new mapping indicates the possibility of different styles of mineralization being present or different places to look.

*Scenario 2:* Elsewhere in a district that you are exploring, a discovery is made which can be used as a new and more relevant model for mineralization than the one that you have been using.

*Scenario 3:* A visit to other mining camps, maybe even on the other side of the world, provides new insight into your exploration property. The formal description of an ore body in the literature is no substitute for seeing it for yourself – particularly if there is an opportunity to see the discovery outcrop.

*Scenario 4:* Newly developed exploration technologies and/or methodologies make it possible to explore effectively in an area where earlier prospecting methods were unsuccessful.

*Scenario 5:* Political changes make available for exploration and mining a part of the world that previously had not been subject to modern methods of exploration.

## 1.4 A Check-List of Negative Assumptions

Sooner or later in most exploration programmes on an area, an impasse is reached in the ability to generate new exploration ideas. At this point, it is always easy to think of many good reasons why the effort should be abandoned. However, before this decision is made, it is worthwhile to critically check through a list of the beliefs that are held about the area. On examination, these beliefs might turn out to be mere assumptions, and the assumptions might be wrong. To assist in this process, here is a check-list of five negative assumptions commonly made by explorationists about the prospectivity of an area.

- The area is not prospective because it is underlain by rock type *X*.

*Comment:* How do you know? The geological map you are using might be wrong or insufficiently detailed. In any case, if rock type *X* is not prospective for your target commodity, perhaps it is prospective for some other commodity.

- The area has already been exhaustively explored.

*Comment:* An area or prospect can almost never be exhaustively tested. Earlier explorers gave up because they ran out of ideas, time or money. The best any explorationist can ever hope to do is to exhaustively test some idea or model that they have about mineralization using the best tools at their disposal at that time. Generate a new model, develop a new tool or simply find new access to risk capital, and the area may turn out to be under-explored.

- All prospective rocks in the area are pegged (staked) by competitors.

*Comment:* When was the last check made on the existing tenements plan? Have all the opportunities for joint venture or acquisition been explored? If you have ideas about the ground which the existing tenement holder does not, then you are in a very good position to negotiate a favourable entry.<sup>7</sup>

- No existing ore-body model fits the area.

*Comment:* Mineral deposits may belong to broad classes, but each one is unique: detailed models are usually formulated after an ore body is found. Beware of looking too closely for the last ore body, rather than the next.

- The prospective belt is excluded from exploration by reason of competing land use claims (environmental, native title, etc.).

*Comment:* This one is tougher; in the regulatory climate of many countries today, the chances are very high that beliefs in this area are not mere assumptions. However, with reason, common sense and preparedness to compromise, patience and negotiation can often achieve much.

## 1.5 Stages in Prospect Exploration

Once a prospect has been identified, and the right to explore it acquired, assessing it involves advancing through a progressive series of definable exploration stages. Positive results in any stage will lead to advance to the next stage and an escalation of the exploration effort. Negative results mean that the prospect will be discarded, sold or joint ventured to another party, or simply put on hold until the acquisition of fresh information/ideas/technology leads to its being reactivated.

Although the great variety of possible prospect types mean that there will be some differences in the exploration process for individual cases, prospect exploration will generally go through the stages listed below.

### 1.5.1 Target Generation

This includes all exploration on the prospect undertaken prior to the drilling of holes directly targeted on potential ore. The aim of the exploration is to define such targets. The procedures carried out in this stage could include some or all of the following:

---

<sup>7</sup>It is usually a legal (and also a moral) requirement that all relevant factual data be made available to all parties in any negotiation on an area. Ideas, however, are your intellectual property, and do not have to be communicated to anyone (you could after all be wrong).

- a review of all available information on the prospect, such as government geological mapping and geophysical surveys, the results of previous exploration and the known occurrence of minerals;
- preliminary geological interpretations of air photographs and remote sensed imagery;
- regional and detailed geological mapping;
- detailed rock-chip and soil sampling for geochemistry;
- regional and detailed geophysical surveys;
- shallow pattern drilling for regolith or bedrock geochemistry;
- drilling aimed at increasing geological knowledge.

### ***1.5.2 Target Drilling***

This stage is aimed at achieving an intersection of ore, or potential ore. The testing will usually be by means of carefully targeted diamond or rotary-percussion drill holes, but more rarely trenching, pitting, sinking a shaft or driving an adit may be employed. This is probably the most critical stage of exploration since, depending on its results, decisions involving high costs and potential costs have to be made. If a decision is made that a potential ore body has been located, the costs of exploration will then dramatically escalate, often at the expense of other prospects. If it is decided to write a prospect off after this stage, there is always the possibility that an ore body has been missed.

### ***1.5.3 Resource Evaluation Drilling***

This stage provides answers to economic questions relating to the grade, tonnes and mining/metallurgical characteristics of the potential ore body. A good understanding of the nature of the mineralization should already have been achieved – that understanding was probably a big factor in the confidence needed to move to this stage. Providing the data to answer the economic questions requires detailed pattern drilling and sampling. Because this can be such an expensive and time-consuming process, this drilling will often be carried out in two sub-stages with a minor decision point in between: an initial evaluation drilling and a later definition drilling stage. Evaluation and definition drilling provide the detail and confidence levels required to proceed to the final feasibility study.

### ***1.5.4 Feasibility Study***

This, the final stage in the process, is a desk-top due-diligence study that assesses all factors – geological, mining, environmental, political, economic – relevant to the decision to mine. With very large projects, the costs involved in evaluation are

such that a preliminary feasibility study is often carried out during the preceding resource evaluation stage. The preliminary feasibility study will identify whether the costs involved in exploration are appropriate to the returns that can be expected, as well as identify the nature of the data that must be acquired in order to bring the project to the final feasibility stage.

## 1.6 Maximizing Success in Exploration Programmes

Obviously not all prospects that are generated will make it through to a mine. Most will be discarded at the target generation or target drilling stages. Of the small numbers that survive to evaluation drilling, only a few will reach feasibility stage, and even they may fail at this last hurdle. The total number of prospects that have to be initially generated in order to provide one new mine discovery will vary according to many factors (some of these are discussed below) but will generally be a large number. Some idea of what is involved in locating an ore body can be gained by considering a prospect wastage or exploration curve (Fig. 1.1). This is a graph on which the number of prospects in any given exploration play (the vertical axis) is plotted against the exploration stage reached or against time, which is the same thing (the horizontal axis). The large number of prospects initially generated decline through the exploration stages in an exponential manner indicated by the prospect wastage curve. On Fig. 1.1, the curve labelled A represents a successful exploration play resulting in an ore body discovery. The curve labelled C represents another successful exploration play, but in this case, although fewer prospects were initially generated, the slope of the line is much less than for play A. It can be deduced that the prospects generated for play C must have been generally of higher quality than the prospects of play A because a higher percentage of them survived the initial exploration stages. The line B is a more typical prospect wastage curve: that of a failed exploration play.

It should be clear from Fig. 1.1 that there are only two ways to turn an unsuccessful exploration programme into a successful one; the exploration programme either has to get bigger (i.e. increase the starting number of prospects generated) or the explorationist has to get smarter (i.e. decrease the rate of prospect wastage and hence the slope of the exploration curve). There is of course a third way: to get luckier.

Getting bigger does not necessarily mean hiring more explorationists and spending money at a faster rate. Prospects are generated over time, so the injunction to get bigger can also read as “get bigger and/or hang in there longer”. There is, however, usually a limit to the number of worthwhile prospects which can be generated in any given exploration programme. The limits are not always (or even normally) in the ideas or anomalies that can be generated by the explorationist, but more often are to be found in the confidence of the explorationist or of those who pay the bills. This factor is often referred to as “project fatigue”. Another common limiting factor is the availability of ground for exploration. In the industry, examples are legion of



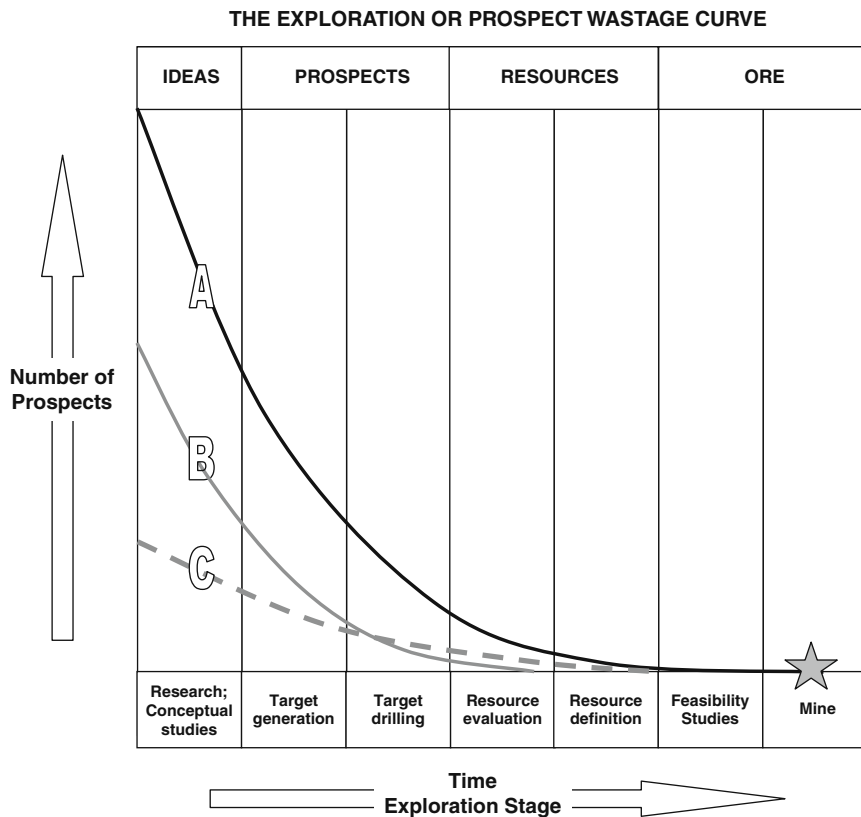

**Fig. 1.1** These curves show how, for any given exploration programme, the number of prospects decreases in an exponential way through the various exploration stages. In a programme based largely on empirical methods of exploration (curve A), a large number of prospects are initially generated; most of these are quickly eliminated. In a largely conceptual exploration program (curve C), a smaller number of prospects are generated, but these will be of a generally higher quality. Most programmes (curve B) will fall somewhere between these two curves

groups who explored an area and failed to find the ore body subsequently located there by someone else, because, in spite of good ideas and good exploration programmes, the earlier groups simply gave up too soon. Judging whether to persist with an unsuccessful exploration programme or to cut one's losses and try some other province can be the most difficult decision an explorationist ever has to make.

Helping the explorationist to get smarter, at least as far as the geological field aspects of exploration are concerned, is the aim of this book. The smart explorationist will generate the best quality prospects and test them in the most efficient and cost-effective manner. At the same time, she will maintain a balance between generation and testing so as to maintain a continuous flow of directed activity leading to ore discovery. The achievement of a good rollover rate of prospects is a sign of a healthy exploration programme.

## 1.7 Different Types of Exploration Strategy

The exploration curve provides a convenient way of illustrating another aspect of the present day exploration process. Some regional exploration methods involve widespread systematic collection of geophysical or geochemical measurements and typically result in the production of large numbers of anomalies. This is an empirical exploration style. Generally little will be known about any of these anomalies other than the fact of their existence, but any one anomaly could reflect an ore body and must be regarded as a prospect to be followed up with a preliminary assessment – usually a field visit. Relatively few anomalies will survive the initial assessment process. The exploration curve for a programme that makes use of empirical prospect generation will therefore have a very steep slope and look something like the upper curve (A) of Fig. 1.1.

The opposite type of prospect generation involves applying the theories of ore-forming processes to the known geology and mineralization of a region, so as to predict where ore might be found. This is a conceptual exploration approach. Conceptual exploration will generally lead to only a small number of prospects being defined. These are much more likely to be “quality” prospects, in the sense that the chances are higher that any one of these prospects will contain an ore body compared to prospects generated by empirical methods. An exploration play based on conceptual target generation will have a relatively flat exploration curve and will tend to resemble the lower line (curve C) on Fig. 1.1.

Empirical and conceptual generation and targeting are two end members of a spectrum of exploration techniques, and few actual exploration programmes would be characterized as purely one or the other. Conceptual generation and targeting tends to play a major role where there are high levels of regional geological knowledge and the style of mineralization sought is relatively well understood. Such conditions usually apply in established and well-known mining camps such as (for example) the Kambalda area in the Eastern Goldfields of Western Australia, the Noranda camp in the Canadian Abitibi Province or the Bushveld region of South Africa. Empirical techniques tend to play a greater role in greenfield<sup>8</sup> exploration programmes, where the levels of regional geological knowledge are much lower and applicable mineralisation models less well defined.

Most exploration programmes employ elements of both conceptual and empirical approaches and their exploration curves lie somewhere between the two end member curves shown on Fig. 1.1.

## 1.8 Exploration Feedbacks

There are many, many times more explorationists than there are orebodies to be found. It is entirely feasible for a competent explorationist to go through a career

---

<sup>8</sup>Greenfield exploration is where there are no pre-existing mines or prospects. This contrasts with brownfield exploration, which is conducted in the vicinity of existing mines.

and never be able to claim sole credit for an economic mineral discovery. It is even possible, for no other reason than sheer bad luck, to never have been part of a team responsible for major new discovery. If the sole criterion for success in an exploration program is ore discovery, then the overwhelming majority of programs are unsuccessful, and most explorationists spend most of their time supervising failure.

But that is too gloomy an assessment. Ore discovery is the ultimate prize and economic justification for what we do, but cannot be the sole basis for measuring the quality of our efforts. The skill and knowledge of the experienced explorationist reduces the element of luck in a discovery, but can never eliminate it. How do we judge when an exploration program was well targeted and did everything right, but missed out through this unknown and uncontrollable factor? How do we know how close we came to success? If successful, what did we do right? And the corollary is this; if we are successful, how do we know it was not merely luck, rather than a just reward for our skills and cleverness? If we cannot answer these questions, it will not be possible to improve our game or repeat our successes.

What is needed is a way to measure the success of an exploration program that is not dependent on actual ore discovery. Probably the best way to judge the success of an exploration program is whether it has been able to define a target from which at least one drill intersection of mineralisation with a potentially economic width and grade has been achieved. This “foot-in-ore” situation may of course have resulted from sheer serendipity rather than from any particular skill on the part of the explorer, but if an explorationist or exploration group can consistently generate prospects which achieve this result, then they must be doing something right. It will only be a matter of time before they find an orebody.

## 1.9 Breaking Occam’s Razor

Occam’s razor<sup>9</sup> is a well known philosophical principle that has universal application in all fields of problem solving. It states that, given a range of possible solutions, the simplest solution – the one that rests on fewest assumptions – is always to be preferred. For this reason the maxim is often referred to as the principle of economy, or even, with more impact, as the KISS principle (Keep It Simple, Stupid). However, Occam’s razor – conjuring up an image of a ruthless slicing away of over complex and uncontrolled ideas – has a certain cachet which the other terms don’t quite capture.

All stages of mineral exploration involve making decisions based on inadequate data. To overcome this, assumptions have to be made and hypotheses constructed to guide decision making. Applying Occam’s razor is an important guiding principle for this process, and one that every explorationist should apply. This is especially true when selecting areas for exploration, and in all the processes which that entails, such as literature search and regional and semi-regional geological, geochemical

---

<sup>9</sup>Named after the fourteenth century English philosopher William of Occam.

and geophysical mapping. However, as the exploration process moves progressively closer to a potential orebody – from region to project to prospect to target drilling – the successful explorationist has to be prepared to abandon the principle of economy. The reason for this is that ore bodies are inherently unlikely objects that are the result of unusual combinations of geological factors. If this were not so, then metals would be cheap and plentiful and you and I would be working in some other profession.

When interpreting the geology of a mineral prospect, the aim is to identify positions where ore bodies might occur and to target them with a drilling program. Almost always, a number of different geological interpretations of the available data are possible. Interpretations that provide a target for drilling should be preferred over interpretations that yield no targets, even although the latter might actually represent a more likely scenario, or better satisfies Occam. However, this is not a licence for interpretation to be driven by mere wish-fulfilment. All interpretations of geology still have to be feasible, that is, it they must satisfy the rules of geology. There still has to be at least some geological evidence or a logically valid reasoning process behind each assumption. If unit A is younger than unit B in one part of an area, it cannot become older in another; beds do not appear or disappear, thicken or thin without some geological explanation; if two faults cross, one must displace the other; faults of varying orientation cannot be simply invented so as to solve each detail of complexity. And so on.

It is relatively easy to find a number of good reasons why a property might not contain an orebody (any fool can do that), but it takes an expert explorationist to find the one good reason why it might.

## References

- Gresham JJ (1991) The discovery of the Kambalda nickel deposits, Western Australia. *Econ Geol Monogr* 8:286–288
- Handley GA, Henry DD (1990) Porgera gold deposit. In: Hughes FE (ed) *Geology of the mineral deposits of Australia and Papua New Guinea*. Australasian Institute of Mining and Metallurgy, Melbourne, 1073–1077
- Helmy HH, Kaindl R, Fritz H, Loizenbauer J (2004) The Sukari gold mine, Eastern Desert, Egypt – Structural setting, mineralogy and fluid inclusions. *Miner Deposita* 39:495–511
- Holiday J, McMillan C, Tedder I (1999) Discovery of the Cadia Au–Cu deposit. In: *New generation gold mines '99 – Case histories of discovery*. Conference Proceedings, Australian Mineral Foundation, Perth, 101–107
- Kelley KD, Jennings S (2004) Preface: A special issue devoted to barite and Zn–Pd–Ag deposits in the Red Dog district, Western Brooks Range, Alaska. *Econ Geol* 99:1267–1280
- Kerr A, Ryan B (2000) Threading the eye of the needle: Lessons from the search for another Voisey's Bay in Northern Labrador. *Econ Geol* 95:725–748
- Koehler GF, Tikkanen GD (1991) Red Dog, Alaska: Discovery and definition of a major zinc–lead–silver deposit. *Econ Geol Monogr* 8:268–274
- Moyle AJ, Doyle BJ, Hoogvliet H, Ware AR (1990) Ladolam gold deposit, Lihir Island. In: Hughes FE (ed) *Geology of the mineral deposits of Australia and Papua New Guinea*. Australasian Institute of Mining and Metallurgy, Melbourne, 1793–1805
- Perello J, Cox D, Garamjav D, Diakov S, Schissel D, Munkhbat T, Oyun G (2001) Oyu Tolgoi, Mongolia: Siluro-Devonian porphyry Cu–Au–(Mo) and high sulphidation Cu mineralisation with a cretaceous chalcocite blanket. *Econ Geol* 96:1407–1428

- Sillitoe RH (2004) Targeting under cover: The exploration challenge. In: Muhling J, Goldfarb N, Vielreicher N, Bierlin E, Stumpfl E, Groves DI, Kenworthy S (eds) Predictive mineral discovery under cover. SEG 2004 extended abstracts, vol 33. University of Western Australia, Centre for Global Metallogeny, Nedlands, WA, 16–21
- Van Leeuwen TM (1994) 25 years of mineral exploration and discovery in Indonesia. *J Geochem Explor* 50:13–90

# Chapter 2

## Geological Mapping in Exploration

### 2.1 General Considerations

#### 2.1.1 *Why Make a Map?*

A geological map is a graphical presentation of geological observations and interpretations on a horizontal plane.<sup>1</sup> A geological section is identical in nature to a map except that data are recorded and interpreted on a vertical rather than a horizontal surface. Maps and sections are essential tools in visualizing spatial, three-dimensional, geological relationships. They allow theories on ore deposit controls to be applied and lead (hopefully) to predictions being made on the location, size, shape and grade of potential ore bodies. They are the essential tool to aid in developing 3-dimensional concepts about geology and mineralisation at all scales. As John Proffett – widely regarded as one of the most skilled geological mappers in the exploration industry of recent decades – has written (Proffett, 2004):

Because geological mapping is a method of recording and organising observations, much of its power in targeting lies in providing conceptual insight of value. Conceptual tools can then help in the interpretation of isolated outcrops and drill hole intercepts that might be available in and adjacent to covered areas.

Making, or otherwise acquiring, a geological map is invariably the first step in any mineral exploration programme, and it remains an important control document for all subsequent stages of exploration and mining, including drilling, geochemistry, geophysics, geostatistics and mine planning. In an operating mine, geological mapping records the limits to visible ore in mine openings, and provides the essential data and ideas to enable projection of assay information beyond the sample points.

Making a geological map is thus a fundamental skill for any exploration or mine geologist.

---

<sup>1</sup>The ground surface is, of course, not always horizontal and, although this can usually be ignored in small-scale maps, it can have profound effects on the outcrop patterns of large-scale maps.

### ***2.1.2 The Nature of a Geological Map***

A geological map is a human artefact constructed according to the theories of geology and the intellectual abilities of its author. It presents a selection of field observations and is useful to the extent that it permits prediction of those things which cannot be observed.

There are different kinds of geological map. With large-scale<sup>2</sup> maps, the geologist generally aims to visit and outline every significant rock outcrop in the area of the map. For that reason these are often called “fact” maps, although “observation” or simply “outcrop” map is a much better term. In a small-scale map, visiting every outcrop would be impossible; generally only a selection of outcrops are examined in the field and interpolations have to be made between the observation points. Such interpolations may be made by simple projection of data or by making use of features seen in remote sensed images of the area, such as satellite or radar imagery, air photographs, aeromagnetic maps and so on. Small-scale maps thus generally have a much larger interpretational element than large-scale maps.

The difference between the two map types is, however, one of degree only. Every map, even at the most detailed of scales, can only present a small selection of the available geological observations and no observation is ever entirely free from interpretational bias. Even what is considered to represent an outcrop for mapping purposes is very much scale dependent. In practice, what the map-maker does is to make and record a certain number of observations, selected from the almost infinite number of observations that could be made, depending on what he regards as important given the purpose in constructing the map. These decisions by the geologist are necessarily subjective and will never be made with an unbiased mind. It is often thought that being biased is a weakness, to be avoided at all costs – but bias is the technique used by every scientist who seeks to separate a meaningful signal from noise. If we were not biased, the sheer volume of possible observations that could be made in the field would overwhelm us. An explorationist has a bias which leads her to find and record on her map features that are relevant to mineralisation. This will not be to the exclusion of other types of geological observation, but there is no doubt that her map will (or at any rate, should) be different from a map of the same area made by, say, a stratigrapher, or a palaeontologist. However, you can only use your bias to advantage if you are aware it of and acknowledge it – otherwise you risk fooling yourself.

A geological map is thus different from other types of map data that the explorationist might use. Although typical geochemical or geophysical maps can contain interpretational elements and bias, they in general aim to provide exact presentations of reproducible quantitative point data. The data on such maps can often be collected

---

<sup>2</sup>By convention, large-scale refers to maps with a small scale ratio (that is, a large fraction) – e.g. 1:1,000 scale or 1:2,500 scale. Small-scale refers to large scale ratios (a small fraction) such as 1:100,000 or 1:250,000. Generally, anything over 1:5,000 should be considered small-scale, but the terms are relative.

by non-professionals and the map can be compiled and plotted by computer according to pre-set formulae. A geological map, on the other hand, is not contoured point data but an analog presentation of ideas; ideas backed up by detailed, careful observation and rational theory but, nevertheless, ideas. To be a successful geological map-maker, it is necessary to keep this concept firmly in mind, and throw out any idea of the geological map-maker as an objective collector of “ground truth”<sup>3</sup> data. After all, one geologist’s “ground truth” may be another geologist’s irrelevant noise.

### ***2.1.3 Intelligent Mapping***

Producing a geological map is a process of problem solving. One of the best ways to approach problem solving is known as the system of multiple working hypotheses.<sup>4</sup> In practice this means that the geologist does not start the field work with a completely blank mind, but armed with ideas about the geology which has to be mapped. These ideas are developed from looking at published maps, from interpreting air photos, satellite images or aeromagnetic data or even by following an intuitive hunch. From these ideas or hypotheses, predictions are made: areas are then selected and observations are made which will most effectively test these predictions. Sometimes this will involve walking selected traverses across strike, sometimes following a marker horizon or contact, sometimes a more irregular search pattern. The mapping sequence depends on the postulated geology: strong linear strike continuity usually indicates that across-strike traversing is the best approach; complex folding or faulting is best resolved by following marker horizons, and so on. In any case, the early working hypotheses will certainly contain several alternative scenarios and may not be precisely formulated; to check them out a very wide range of field observations will have to be made and a mix of different search patterns may need to be followed. The geologist at this stage must be open to all possible ideas, hypotheses and observations. If the observations do not fit the hypotheses, then new hypotheses must be constructed or old ones modified to accommodate the observations. These new hypotheses are then tested in their turn, and so the process is repeated.

With each step in the process the predictions become more precise and the search pattern more focused on to the key areas of interest. These are the usually areas where significant boundary conditions can be defined in the outcrop. Most of the time of the intelligent mapper is thus spent in the areas of “fertile” outcrop where there is most to be learned, and less time is spent in those areas where the rocks are uniform – in the latter areas a lower density of observation will serve (Fig. 2.1).

---

<sup>3</sup>“Truth” and “fact” are slippery concepts that are often employed to claim authority and stifle debate. They are best not used in scientific contexts.

<sup>4</sup>The concept of multiple working hypotheses, now widely acknowledged as a basic part of the scientific method, was first enunciated by geologist Thomas Chamberlin (1897).



**Style 1: The systematic data collector (the mindless slogger)**

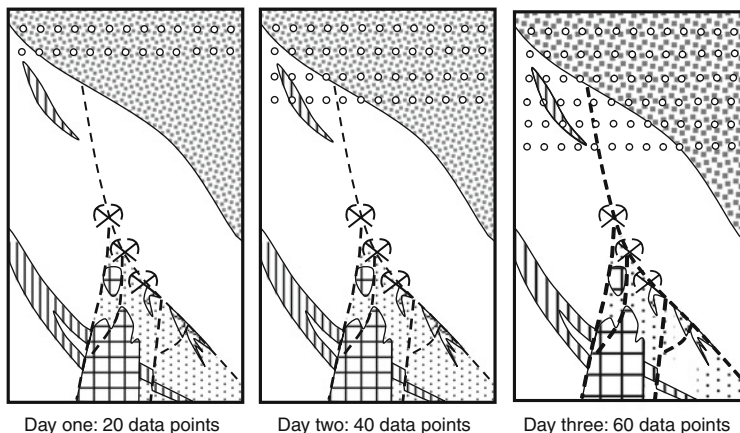

**Style 2: The ideas-driven intelligent mapper**

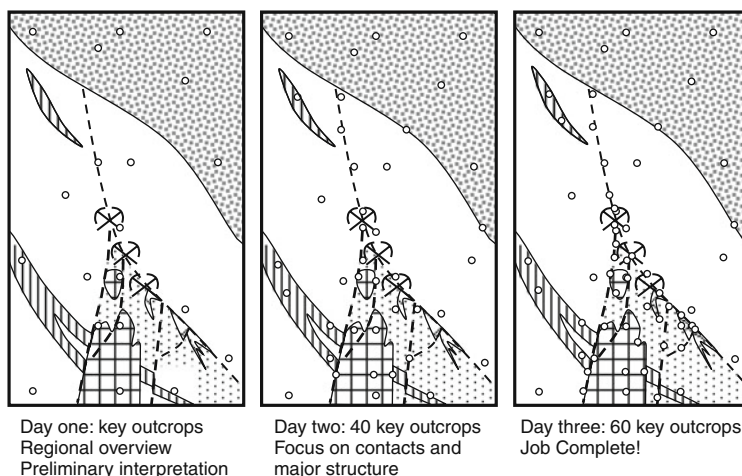

**Fig. 2.1** Comparison of geological mapping styles. In the first case, the “systematic data collector”, driven by a pre-determined inflexible strategy rather than ideas, regularly traverses the ground. The task will eventually be completed, but this is not the most efficient procedure. The intelligent mapper on the other hand continuously assesses the significance of each outcrop against evolving ideas about geology, and then determines strategy in the search for the next significant outcrop. The job is completed more quickly, and better too

Many small structural features can be observed in individual outcrop or hand specimens that allow predictions to be made about large structures occurring at the scale of a map. Most useful of such observations are the predictable geometrical relationships that occur between bedding, cleavages, lineations and folds, as well as movement indicators that can be used to deduce the sense of movement on brittle faults and ductile shear zones. Where such structures as these occur, they are a boon

to the field mapper, and he should learn to recognize and make use of them. A detailed description of these structures is beyond the scope of this book but they are treated in many standard geology texts. Some useful references will be found in Appendix F.

Another aspect of rocks is the way the features and relationships seen in hand specimen or outcrop often exactly mirror features occurring at map scale. This has been informally called “Pumpelly’s Rule” after Raphael Pumpelly, the nineteenth century USGS geologist who first described it.<sup>5</sup> Once again the intelligent mapper will be on the look out for such potential relationships in outcrop as a means of developing ideas as to the map scale geological patterns.

With geochemistry having a major role in most modern exploration programmes, the geological map will usually play a large part in the planning and understanding the results of surface geochemical sampling programmes. In order to fulfil this role, exploration geological mapping in most cases will need to carefully show the distribution of superficial and weathered rock units (the regolith), as well as bedrock features.

Observations are thus not made randomly, nor are they collected on a regular grid or according to a fixed search pattern; rather they are selected to most effectively prove<sup>6</sup> or disprove the current ideas. Geological mapping is a scientific process and when carried out properly corresponds to the classic scientific method: theorizing, making predictions from the theories, and designing experiments (planning the required field observations) to test the predictions.<sup>7</sup>

An aspect of this technique is that thinking and theorizing are constantly being done while field work proceeds. In other words, data collection is not a separate and earlier phase from data interpretation; these two aspects are inextricably linked and must proceed together. Above all, observation and interpretation should never come to be regarded as “field work” and “office work”.<sup>8</sup>

---

<sup>5</sup>Today we recognize that geological processes are essentially chaotic (i.e. non-linear). Such systems typically exhibit what is called “scale-invariance”, meaning there is a repetition of characteristic patterns at different scales – the example often quoted being the comparison in shape between a rock pool and the coastline of which it is an element. Pumpelly’s Rule is an early recognition of this type of relationship (see Pumpelly et al., 1894).

<sup>6</sup>Actually, as pointed out by the philosopher of science Karl Popper (1934), an experiment either falsifies a hypothesis or expands the range of conditions under which it can be said to hold good: it can never prove it.

<sup>7</sup>All theories in science, and that includes ideas on geology, must be formulated in such a way that they are capable of being falsified. For example, for field mapping purposes it is not very useful to postulate that “these outcrops constitute a metamorphic core complex” because there is unlikely to be a simple observation which can falsify that statement. Rather postulate “this outcrop is felsic gneiss, that outcrop is sandstone, this contact is a mylonite” – if these turn out to be false then the hypothesis may need revision.

<sup>8</sup>In our society from the earliest training we are unfortunately conditioned to think indoors, and to enjoy less cerebral pursuits outdoors. It is a syndrome that the field geologist must learn to break.

### ***2.1.4 Choosing the Best Technique***

The mapping technique used depends upon the availability of suitable map bases on which to record the field observations. A summary of the different techniques is given in Table 2.1.

The ideal base is an air photograph or high resolution satellite image, as these offer the advantages of precise positioning on landscape/cultural/vegetation features combined with an aerial view of large geological structures that cannot be seen from the ground. For small-scale maps (say 1:5,000–1:100,000) remote sensed images are virtually the only really suitable mapping base, although if good topographic maps are available at these scales they can be used as a second-choice substitute. In Third World countries, where there is often no aerial photography available at any suitable scale, satellite imagery can provide a suitable base for regional geological mapping. Radar imagery, whether derived from satellite systems or special aircraft surveys, can also be used as a geological mapping base in much the same way as aerial photography.

In the special case of mine mapping, the mapping base is usually a survey plan of the mine opening prepared by the mine surveyor and supplemented by accurately established survey points from which distances can be taped. In open-cut mines, most available rock surfaces are vertical or near-vertical; observations are thus best recorded onto sections and afterwards transferred to the standard level plans, a composite open-cut plan or mine sections. In underground mines, observations can be made on the walls, roofs and advancing faces of openings, and are then recorded and compiled onto a section or plan. These mapping techniques are detailed in subsequent sections.

For surface mapping, suitable photography is often not available or is only available at too small a scale to permit photo enlargement for detailed mapping purposes. In many cases also, air photographs are difficult to use for precise field location because of vegetation cover or simply because of a lack of recognizable surface features. In areas of very high relief, photos can also be difficult to use because of extreme scale distortions. In these cases, alternative techniques are available to provide the control for detailed mapping. In order of decreasing accuracy (and increasing speed of execution) these mapping techniques are: plane table mapping, mapping on a pegged grid, tape and compass mapping, and pace and compass mapping.

Plane table mapping is seldom done nowadays because it is slow and the alternative use of pegged grid control can provide all the surveying accuracy that is normally required for a geological map. Further disadvantages of the plane table technique are the requirement for an assistant and the fact that geological observation and map-making usually have to be carried out as two separate processes. However, plane tabling provides great survey accuracy and is an invaluable technique where precision is needed in mapping small areas of complex geology. Such situations often arise in detailed prospect mapping or in open-cut mine mapping. The plane table technique is also indicated where a pegged grid cannot readily be

**Table 2.1** Comparison of mapping techniques

Mapping technique	Ideal scales	Indications	Advantages	Disadvantages
Pace and compass	1:100–1:1,000	Rough prospect map. Infill between survey points	Quick. No assistance and minimal equipment needed	Poor survey accuracy, especially on uneven ground
Tape and compass	1:100–1:1,000	Detailed prospect maps. Linear traverse maps. Mine mapping	Quick. Good accuracy. No preparation needed	May need assistance. Slow for large equidimensional areas
Pegged grid	1:500–1:2,500	Detailed maps of established prospects	Fair survey accuracy. Relatively quick. Same grid controls/ correlates all exploration stages	Expensive. Requires advance preparation. Poor survey control in dense scrub or hilly terrain
Plane table	1:50–1:1,000	Detailed prospect mapping in areas of complex geology. Open cuts	High survey accuracy. No ground preparation required	Slow. Requires assistance. Geological mapping and surveying are separate steps
GPS and DGPS	1:5,000–1:25,000	Regional and semi-regional mapping. First pass prospect mapping	Quick, easy downloadable digital survey data. Good backup for other techniques at similar scales	Encourages geological mapping as collection of point data
Topographic map sheet	1:2,500–1:100,000	Regional mapping and reconnaissance. Areas of steep topography. Mine mapping. Base for plotting GPS observations	Accurate georeferenced map base. Height contours	Difficulty in exact location. Irrelevant map detail obscures geology. Not generally available in large scales
Remote sensed reflectance imagery	1:500–1:100,000	Preferred choice. Ideal geological mapping base at all scales	Geological Interpretation directly from image. Stereo viewing. Easy feature location	Scale distortion (air photos). Expensive if new survey needs to be acquired

used, for example, mapping a disused quarry or open cut. Plane table mapping is therefore a useful skill for a field geologist to acquire.

Pegged grids are used for outcrop mapping at scales of 1:500–1:2,500 and are a commonly used survey control for making detailed maps. The technique relies on placing a close network of survey pegs into the ground at regular stations on a Cartesian coordinate system (see Sect. 10.5.2). The coordinates are marked onto the pegs that are then placed in the ground to provide control for all stages of exploration over the area. The disadvantages of using a pegged grid lies in its expense, and the danger that geologists often come to regard the grid as a series of predetermined geological traverse lines, rather than a pre-positioned network of points for survey control.

A measuring tape and compass or Hip-Chain<sup>TM</sup> and compass survey allows for quick production of detailed prospect maps, or maps to provide a base for location of sample points in areas where the geologist cannot spend long on site. With this technique it is possible to produce a high-quality, detailed geological map without needing any advance preparation (provided there is a tape or hip-chain available<sup>9</sup>).

If there is no measuring tape available then pacing distances can still allow a rough map to be constructed. Pacing is better than estimation and has the advantage of being quick. Pacing can even be reasonably accurate for short distances over open flat ground. Explorationists should be aware of their normal pace length by laying out a 100 m tape along flat even ground and checking pace length by walking back and forward many times (using a normal, easy stride) and taking an average. Every time a pegged grid line is walked, the pace length over different types of terrain should be checked.

### ***2.1.5 Choosing the Best Scale***

The scale chosen for mapping controls the type of data which can be recorded and hence the type of observations which are made in the field (see Fig. 2.2). The choice of appropriate scale depends on the purpose in making the map.

A small-scale map – say at 1:25,000 or smaller – shows broad regional patterns of rock distribution and major structures. From an exploration point of view this is the scale at which the prospectivity of a basin, fold belt, tectonic unit or other large geological subdivision might be determined. It is a scale appropriate for developing ideas for new project generation. Explorationists do not often make maps at these small scales. There are two reasons for this: firstly, this is the type of mapping undertaken by Geological Surveys and can often be bought off the shelf; secondly,

---

<sup>9</sup>Hip-Chain<sup>TM</sup> is a reel of disposable, biodegradable cotton thread. As it reels from its spool, a meter records the length wound off, and hence the distance travelled. The thread is then simply broken and left on the ground. Other brand names for similar measuring instruments are Fieldranger<sup>TM</sup>, Chainman<sup>TM</sup> and Topofil<sup>TM</sup>.

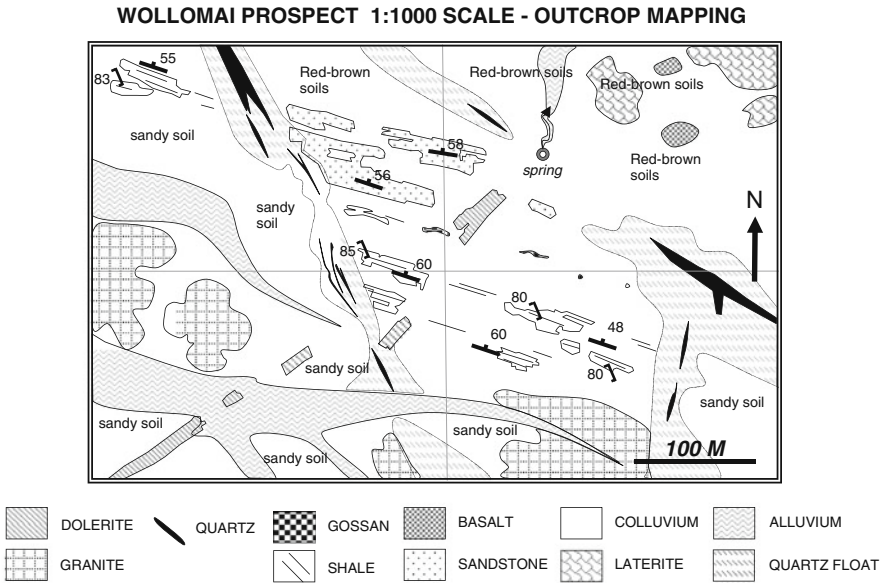

**Fig. 2.2** How the scale chosen affects the style and content of geological maps of the same area. Generalisation is required at all scales. There is no such thing as a “fact” map. However, the component of field observation is greatest in large-scale maps

explorationists in most cases cannot obtain a sufficiently large tenement holding to make this kind of mapping worth while.

Maps with intermediate-range scales between 1:25,000 and 1:5,000 can be described as detailed regional maps. These are appropriate scales for the first-pass mapping of large tenement holdings. They are also ideal scales to use when

combining geological mapping with regional prospecting or regional geochemistry (such as stream sediment sampling). At scales in this range, some of the larger features which might have had an effect on the localization of ore are capable of being shown, although the outline of an ore deposit itself could not generally be shown. The intermediate range of map scales is therefore suitable for the control and development of new prospect generation.

On maps at scales more detailed than 1:5,000, individual outcrops or outcrop areas and the surface expression of significant areas of mineralization can be shown. These scales are appropriate for showing the features that directly control and localize ore. Maps at these scales are often called outcrop maps and the need to make them generally arises after a prospect has been defined. The purpose of such maps is to identify the size, shape and other characteristics of the potential ore body. The map is then used to help specify, control and evaluate all subsequent programmes of detailed prospect exploration including geophysics, geochemistry and drilling.

### ***2.1.6 Measuring and Recording Structures***

To fully define and understand the attitude of a planar surface such as a bedding plane, cleavage, joint, vein etc., a geologist needs to know its strike, its dip and the direction of the dip towards one of the principal compass quadrants. Of these measurements, the strike is usually the most important, because it is that which defines the potential continuity of the surface in the horizontal plane of a geological map, or between the adjacent sections of a drilling program. When measurements are recorded digitally (as opposed to analog recording as a strike and dip symbol on a map) the most common traditional way has been in the form of  $xxx/yy/A$ , where  $xxx$  (the strike) is a 3-digit compass bearing (000–360°),  $yy$  (the dip) a two digit number representing the angle from the horizontal (00–90°) and  $A$  is the direction of dip towards a principal compass direction or quadrant (i.e. *N, NE, E, SE, S, SW, W* or *NW*). As an example: *042/23 NW* is a surface with strike of 42° that dips at 23° to the northwest. Because this method requires three data fields (strike, dip and dip direction) the advent of computer-based databases has led to a variety of other ways, utilising only two data fields, being employed for digital recording of the measured attitude of planes. These involve recording attitude as dip and dip direction, or as a simple strike and dip with the dip direction qualifier recorded by means of a convention in the way the strike number is expressed. The most common of these conventions is the so-called “right-hand rule”. This rule can be explained thus: imagine grasping a strike/dip map symbol with the right hand, palm down and fingers pointing in the direction of dip. The thumb then indicates the strike direction to be recorded. For example: an east-west strike (090–270°) with a 60° dip to the north would be recorded as *270/60*. A record of *090/60* would indicate the same strike but a dip of 60° to the south.

These different methods of recording the attitude of planes are described and discussed in detail in Vearncombe and Vearncombe (1998).

The attitude of linear structure is measured and recorded as its trend and plunge (see Fig. E.4). Trend is defined as the horizontal direction or strike of a vertical plane passing through the lineation, measured in the direction of plunge. It is recorded as a compass bearing between 000 and 360°. Plunge is the angle that the lineation makes with the horizontal, measured in the vertical plane. A measurement of 76/067 represents a plunge of 76° towards 067°. If a lineation lies in a plane, then it can be measured as its pitch on that plane. A pitch is the angle that a lineation makes with the horizontal, measured in the plane that contains the lineation. If the attitude of the plane is also known, then knowing the pitch enables the trend and plunge to be calculated. The simplest way to do this is by means of a stereonet (Fig. D.2).

Any computer software used should be capable of accepting and presenting data in all the above formats.

### ***2.1.7 Using Satellite Navigation (GPS)***

Small, battery-operated, man-portable instruments have been available since the late 1980s to make use of the satellite-based global positioning system (GPS).<sup>10</sup> They are a boon to many aspects of field geology. Since the GPS provides location data based on latitude/longitude or regional metric grid coordinates, it is of most value for fixing position or navigating on a published map sheet on which these coordinates are marked.<sup>11</sup> This makes GPS ideal for regional geological mapping onto published map bases or for regional prospecting and regional and detailed geochemical and geophysical data collection. Observations and sample locations can be quickly recorded against location coordinates and the position of each data point readily found again should that become necessary. In addition, the explorationist can roam around the country on foot, by vehicle or plane, following outcrop, evolving ideas or hunches, confident that anything interesting found can be easily located again, and, at the end of the day, the GPS instrument will provide a direct route back to base camp.

Some limitations in the operation of GPS instruments should be noted however:

- For the most accurate location signal, GPS devices need an unobstructed line of sight to the satellites. At least four widely spaced satellites must be “seen” for an accurate triangulated fix to be computed. This means that GPS will not work well in heavily wooded or forested areas except where large clearings can be found.<sup>12</sup>

---

<sup>10</sup>GPS is operated by the US Department of Defence and is available free to all civilian users. At the time of writing (2010) it is currently the only commercially-available available GPS system. From 2013, on current estimates, the European Galileo satellites will provide an alternate coverage.

<sup>11</sup>The most commonly used grid is Universal Transverse Mercator metric grid (UTM). A description of coordinate systems will be found in Sect. 10.5.

<sup>12</sup>However, in forested areas, GPS is a boon for airplane or helicopter operations. The geologist dropped off in a clearing in the rain forest to collect a stream sediment sample need never again fear that the helicopter pilot will not be able to find that particular hole in the canopy again.



The presence of adjacent cliffs or rock faces (such as might be encountered in a mine open cut) can also seriously degrade the satellite signal and lead to lower levels of accuracy, or even a complete absence of signal.

- At the time of writing (2010) the GPS system only provides a maximum consistent accuracy from small hand-held units of 10–15 m in the horizontal direction. Maximum potential errors in altitude are generally slightly greater. That means that a GPS position plotted onto a map could lie anywhere within a circle of 20–30 m diameter. This provides a practical limit to the scales at which hand-held GPS-controlled mapping can be employed. A position error of 30 m at 10,000 scale is 3 mm. This might be acceptable, but at 1,000 scale the equivalent potential 30 mm error in plotting a point on a map would not.

Better GPS accuracy can be provided by averaging a number of fixes over a period (some GPS units can do this automatically) but this process takes time. High accuracies of the order of  $\pm 3$  m can be achieved by the use of two time-coordinated GPS units, the location of one of which is fixed. This is known as differential GPS (DGPS). For it to provide fixes in real time there has to be a short-wave radio link between the mobile and fixed GPS units. Alternatively, data from the two units can be subsequently downloaded to computer, and an accurate position calculated. The highest GPS accuracies (maximum errors around 1 m) are obtainable by making use of special GPS correction radio signals. These systems make use of signals from geostationary satellites to calculate a correction map for their area of coverage. DGPS equipped receivers can then make use of this data to correct their position fix. However, at the time of writing, these signals are only available in some areas of the developed world. In the United States the system is called the WAAS system (Wide Area Augmentation Service), in Europe as EGNOS (Euro Geostationary Navigation Overlay Service) and in Japan as MSAS (Multifunctional Satellite Augmentation System). High accuracy DGPS systems are normally employed for accurate surveying applications (such as for aircraft navigation systems, accurate land surveying (i.e. claim boundaries) or levelling gravity stations), but at present have limited application for a geologist trying to create a large scale geological map in the field.

- Relying exclusively on GPS for navigation can create problems (potentially serious) should the unit become inoperative. Never rely on GPS to the point where, if the instrument stops working for whatever reason, you cannot find your way safely back to base.
- GPS cannot be used to provide accurate positioning on air photographs since these lack coordinates and contain scale and angle distortions. However, it is still useful to approximately locate oneself on a photo by using the GPS to provide a distance and bearing to a known feature of the photo scene. That feature has been previously entered as a waypoint in the GPS instrument's memory. In most cases, knowing an approximate position on an air photo will enable an exact fix to be quickly obtained by means of feature matching. Ground-located photo features for entering as waypoints should ideally be located in the central two-thirds of the photo scene, where distortion of the image is minimal.

- Plotting latitude and longitude coordinates in the field is difficult. Metric grid coordinates such as UTM (Universal Transverse Mercator, for a detailed description see Sect. 10.5) are much easier to use. Make sure your GPS unit can provide a fix in latitude/longitude and regional metric grid coordinates.
- In many parts of the Third World where explorationists operate, available published maps are often based on poor-quality photogrammetry with little or no ground checking. Such maps can be highly inaccurate. Even where photogrammetry-based maps have been made with care, in heavily forested country the map-maker has often been unable to accurately position smaller streams, roads or villages because of the obscuring tree canopy. In these areas, the GPS fix, being more accurate than the map, can be very misleading when it comes to trying to locate a particular feature.

## 2.2 Mapping Using Reflectance Imagery as a Map Base

### 2.2.1 *General*

Light from the sun reflects from the earth's surface and radiates in all directions, including (provided it is not blocked by clouds) back into space. Any system which can record the intensity and wavelengths of the reflected light and reproduce the data as an image, is known as reflectance imagery. The instrument that does this can be mounted on either an aircraft or satellite. The word photograph is specifically used for images recorded onto photographic film by a camera lens system. This section deals primarily with air photographs – i.e. photographs taken looking vertically down from an aircraft – but most of the comments apply equally to the handling and use of hard copy satellite images. Details about how satellite images are acquired and presented, and how they can be used as a remote sensing geophysical tool (spectral geology), will be found in Chap. 8.

In air photography, a camera mounted in an aircraft takes a series of photographs as the plane flies in regular parallel passes over the terrain. Air photographs have the advantage of being relatively cheap to collect and, since they are taken at low altitude, can show great detail. Overlapping adjacent photographs along the flight path (Fig. 2.3) enables subsequent stereoscopic (3-dimensional) viewing (Fig. 2.5). Air photographs typically offer a resolution of ground features that range in size from a few centimetres upwards, depending on the height of the aircraft above the ground and the quality of the camera optics used. Film is an analog method of recording data that offers exceptionally high resolution that is ultimately limited only by the grain size of the chemical emulsion on the film. The resolution of the film used for air photographs is an order of magnitude greater than is currently achievable with electronic recording methods. Air photographs are typically collected for normal viewing at scales of from 1:500 to 1:100,000, but, unlike digital images, they can be enlarged many times without losing resolution.

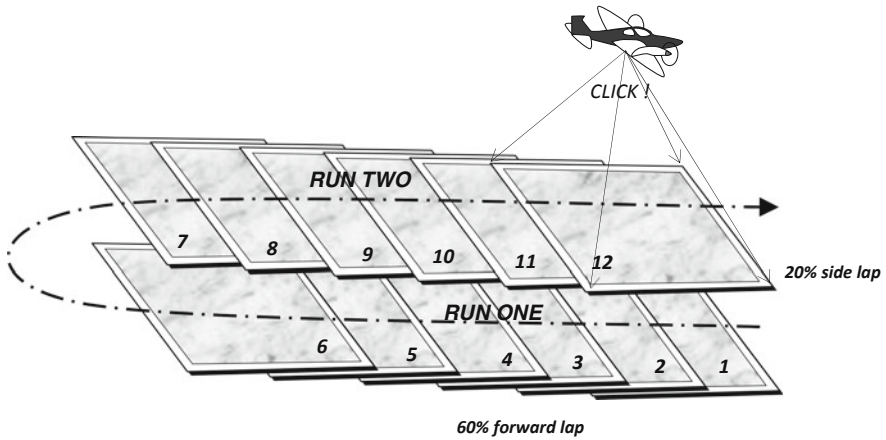

Fig. 2.3 Typical specification of an air photo survey designed to obtain full stereo coverage

### 2.2.2 Acquiring Air Photographs

Many governments (including all first world countries) have acquired air photo coverage of their territories and these can usually be purchased from the relevant government agency. Needless to say, the quality and coverage of this product varies enormously, but since it is a cheap resource, it is always worth checking to see what is available. In areas where there has been a high level of mineral exploration, surveys flown by previous explorers may also be available. If none of these avenues yields a useful product, it is possible to commission your own survey. This is comparable in cost to purchasing high resolution satellite imagery for the same area and gives the opportunity to specify a scale and coverage that will suit your project.

### 2.2.3 Geological Interpretation

Air photographs (along with other similar remote sensed products such as satellite and radar imagery) provide both a mapping base on which to record field observations and an integrated view of landscape on which map-scale patterns of lithology and structure can be directly observed or interpreted. Where available at a suitable scale and resolution, they are the pre-eminent medium upon which to construct a geological map.

For any geological mapping programme making use of remote sensed imagery, image interpretation represents the idea-generating, integrative, control and planning phases of that programme. The initial interpretation made from the images will provide:

- definition of areas of outcrop and areas of superficial cover;
- preliminary geological interpretation based on topographic features, drainage patterns, colours and textures of rocks, soils and vegetation, trend lines of linear features, etc.;
- geological hypotheses for field checking;
- selection of the best areas to test these hypotheses;
- familiarity with the topography and access routes to assist in logistic planning of the field programme – access roads and tracks, fording points for streams and gullies, potential helicopter landing sites, etc.

Air photo or satellite image interpretation needs to be carried out before, during and after the field phases of the mapping process. Obviously, detailed interpretation making use of stereo viewing can be most conveniently done at an office desk, but, as ideas change or evolve, interpretation of photo features will have to be attempted in the field as well. The ability to use a pocket stereoscope on the outcrop is an essential skill to acquire.

Since making and interpreting geological observations on the photo and outcrop are two aspects of the same process, they should ideally be carried out by the same person.<sup>13</sup> Whenever possible, the field geologist should do his own interpretation.

Geological interpretation of remote sensed imagery complements field mapping and should never be regarded as an adequate substitute for it.

Skills required for the geological interpretation of remote sensed imagery are very much the same as those needed for field mapping. However, some practical techniques need to be learned in order to turn air photo observations into usable geological maps. The next section describes some of these techniques.

### 2.2.4 Determining Scale

The scale of an air photograph is determined by the height above the ground of the airplane taking the photograph, divided by the focal length of the camera used (Fig. 2.4). Thus:

$$\text{Photo scale} = 1: \frac{\text{Airplane height above ground}}{\text{Focal length of camera}}$$

A scale is generally printed onto the edge of an air photograph but this is a nominal scale only and should always be checked for a number of scenes across the area of the air photo survey.

---

<sup>13</sup>Highly skilled and experienced geologists are available who specialize in the field of air photo and satellite image interpretation. Their use is indicated for training purposes; where they have particular knowledge of the geology or landforms in the area to be mapped; or where there is little possibility of any substantial field access to the region.

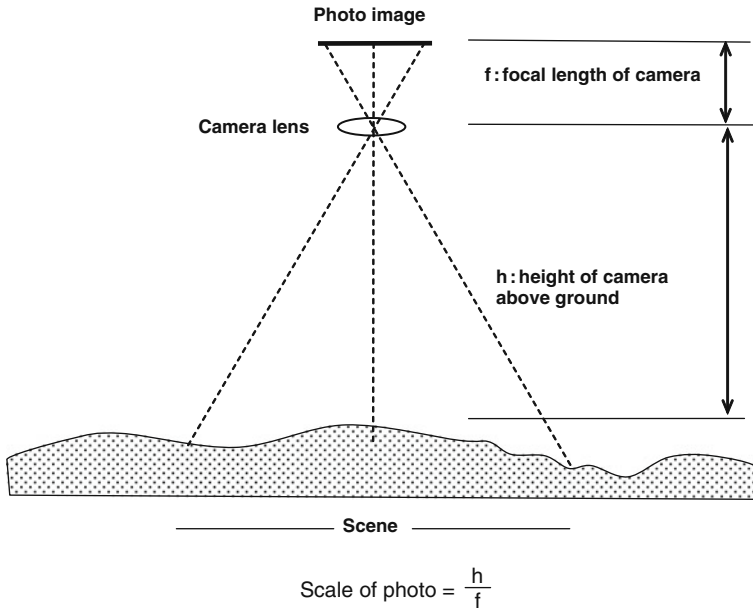

**Fig. 2.4** How to calculate the scale of an air photograph

The airplane altimeter height (i.e. height above sea level) and camera focal length are also normally marked on to the edges of an air photograph and provide a means of calculating the exact scale, using the above formula, provided the average height of the ground above sea level is known for that scene. Cameras designed for photographic surveys have very long focal lengths to enable them to fly at greater heights for a given scale.

Even though the pilot of the plane tries to maintain a constant ground height whilst flying a photographic survey, this is not always possible. The scale can thus vary from image to image. The variation in scale from this cause is usually small, but is greatest for large-scale photographs and in areas of strong relief.

Another way of checking the scale is to measure the length of a known feature in the central portion of the photo (such as a section of road or stream) and compare it with the same section identified on a detailed topographic map of the same area. Make several such measurements along different bearings on each image and take the average to get the true scale for the scene.

In addition to these scale variations, the stated photo scale is correct only for the central area of the photograph and is progressively distorted towards its edges. Since the distortion increases exponentially outwards, the central 60% of the scene has only minimal distortion which can generally be ignored. The radial distortion also affects angular relationships. For this reason, if at all possible, interpretation should not be carried to the edges of a photograph. This is easy to do on the edges of photos along the flight line (the forward lap) where a 60% overlap is usually

available with adjacent frames, but more difficult on the photo edges across the flight line (the side lap) where the overlap with adjacent runs is generally only 20%<sup>14</sup> or less.

Air photos usually have a north arrow plotted on their edge but this arrow cannot necessarily be taken as accurate – any yawing of the plane at the moment when the photo was taken can make this considerably in error. This problem will usually affect only a few photographs and can be picked up and corrected when adjacent photos are compared during the initial interpretation period. It is a good idea to compare each photo with a topographic base map and, where necessary, correct the north arrow marked on the photograph.

### 2.2.5 Stereoscopic Image Pairs

When images of a feature from two different angles are taken, there is a relative shift in the apparent position of the feature on the images. This effect is known as parallax. The two images form a left and right stereo pair and, taken together, contain three dimensional information about the feature. To recover this information, the images must be arranged for viewing so that the left eye sees the left image and the right eye sees the right image. The brain then combines the two views to create a three-dimensional impression of the feature, in exactly the same way as the eye-brain combination would have created three-dimensional information if they had directly viewing the feature in the real world.

Images are normally placed for viewing at a distance of around 200 mm from the eyes (H – height), and eyes are approximately 55–65 mm apart (B – base distance). On viewing stereoscopic image pairs, the ratio of height to base (H:D) is therefore around 3. If the same ratio is used during acquisition of the images there will be no scale distortion on viewing. For example, to take scale-correct stereoscopic photographs of an outcrop in the field, follow the procedure:

1. photograph the outcrop – this becomes the left image;
2. estimate the distance (H) to the outcrop (say, 12 m);
3. step a distance of H/3 (B) to the right (4 m in our example) and take a second photograph of the outcrop – this becomes the right image.

When subsequently mounted side by side on the page of a notebook or report, the two images, when viewed so that the left eye sees the left image and the right eye the right image; will give a distortion-free 3-dimensional view of the outcrop.

Figure 2.5 illustrates an air photo survey with a plane flying at 200 m taking photographs of the ground beneath it every 65 m. For this survey the ratio of H to B is 3

---

<sup>14</sup>Photography for mountainous areas, where flying predetermined flight lines may be difficult, needs a wider side lap of 25% or more.

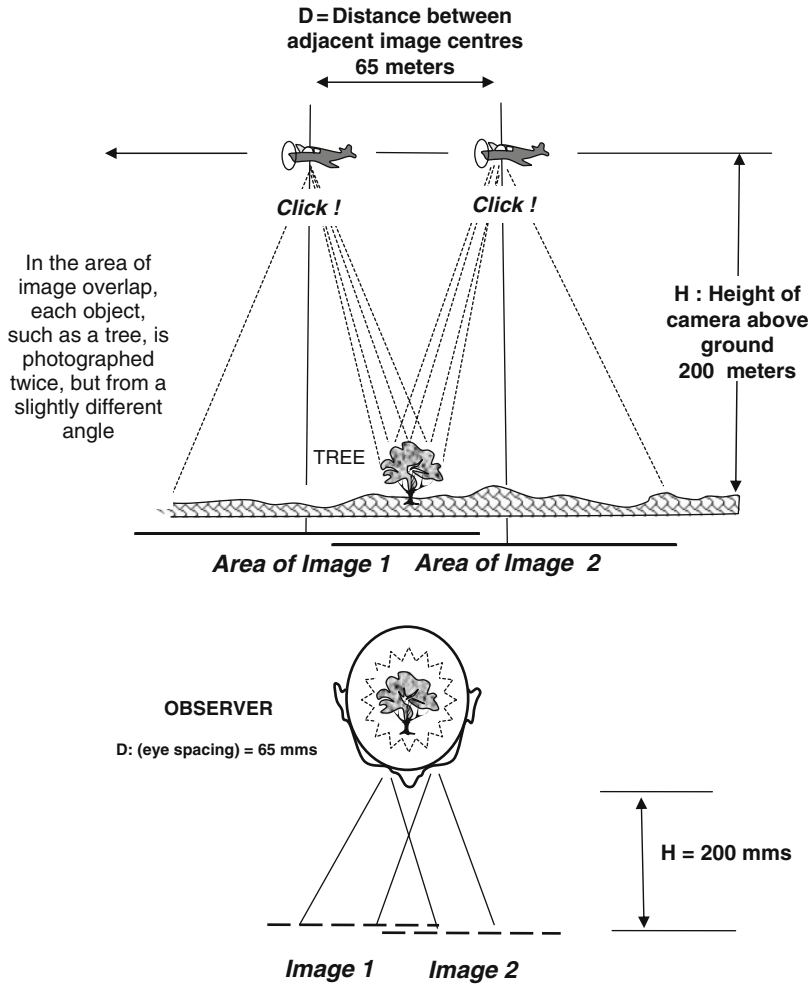

**Fig. 2.5** How the perception of depth in a stereoscopic photo pair is determined. When viewing images, the ratio of the distance between the eyes (D) and the distance to the image (H) is approximately 3. If the images have been collected using the same ratio of D to H – as illustrated – there will be no vertical scale distortion on viewing. If the ratio of H/D is greater than 3 (which would occur if the photos were taken closer together or from a greater height above ground) viewing the stereo pair will exaggerate the apparent height of object

so there will be no vertical exaggeration when viewing adjacent images stereoscopically. However, with almost all air photo surveys, a height to base ratio of 3 would entail flying very low and require an unacceptably large number of photographs to cover any significant area. Because of this, most surveys are flown with an H:B ratio greater than 3, leading to an exaggeration of the vertical dimension on stereoscopic

viewing – i.e. objects appear much steeper than they are in reality. Vertical exaggeration can be a useful feature in very flat terrain, as small height variations are emphasised, but in rugged terrain the effect can be rather startling, and needs to be allowed for. Dips of outcropping strata, for example, will appear much steeper than they really are.

With practise it is possible to view small stereo pairs and get the stereo effect without any optical aid. This can be a handy skill to acquire, but it will only ever work for small size images that can be placed close together. Optical instruments called stereoscopes make this process much easier and they are essential for viewing large format images. The smallest and cheapest stereoscopes are small folding models (Fig. 2.6) – these can be very useful for viewing air photographs in the field. However, pocket stereoscopes have generally poor optics and offer no, or very low, magnification. A further disadvantage is that with standard size air photographs it is necessary to bend back the edge of one print in order the view the entire overlap area of a photo pair.

To achieve the full benefit from stereoscopic viewing of air photographs or satellite images, a mirror stereoscope is necessary. Many different models of mirror stereoscope are commercially available, but it is important to remember that with these, as with all optical instruments, you get what you pay for. The best models come with binocular eyepieces and offer enlargements of the image up to 10× (Fig. 2.6). Large mirror stereoscopes will comfortably span a pair of air photographs, although the instrument has to be moved from side to side and back and forward to cover the full overlap area. If the stereoscope is mounted on a frame that permits unimpeded horizontal movement above the images the viewing process can be made considerably easier. Such mounting frames are essential for viewing very large format stereoscopic pairs such as satellite images. Commercial frames (often called mounting “tables”) are available but these are expensive and sometimes make annotation of the images difficult. Figure 2.6 illustrates a cheap and easily made homemade stereoscope mounting frame which has proved very effective for geological interpretation<sup>15</sup> of air photographs and satellite images.

### 2.2.6 Image Handling Techniques

- Surface reflectance can be a problem on highly glazed prints. Such prints also tend to curl and dog-ear more easily than matt prints. For this reason most geologists prefer to order prints with a matt surface for fieldwork. However, high-gloss prints reflect more light and for that reason can be easier to read below a film overlay.

---

<sup>15</sup>The frame is made from wood and aluminium angle. It is articulated using standard wheeled drawer runners.



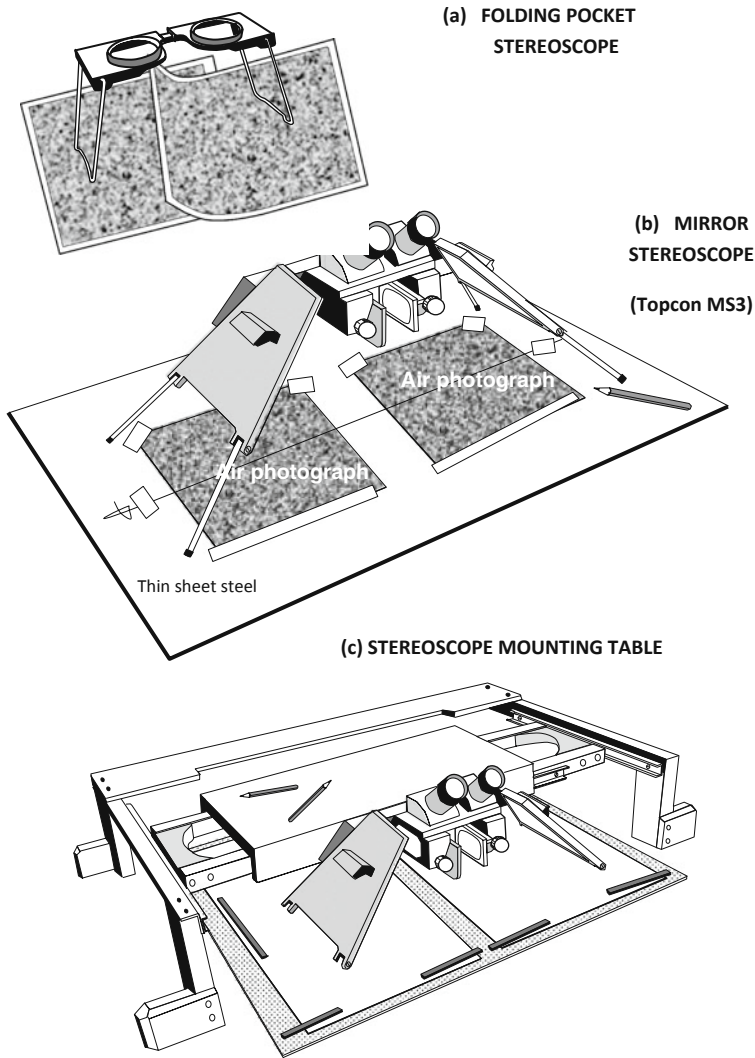

**Fig. 2.6** Different types of stereoscope. With a small pocket stereoscope (a) the edge of one photograph needs to be bent back in order to view the whole overlap area of air photographs. A large mirror stereoscope (b) will span a pair of standard air photographs and can be easily slid around to view the whole image. A stretched thread is used as an aid in aligning photo centres with the optical axis of the scope. The steel sheet allows plastic strip magnets to be employed to hold photos flat and in place. For stereoscopic viewing of large prints such as satellite images, mounting the stereoscope in a frame (c) that allows it unimpeded movement above the images is essential. The mounting table illustrated was made by the author from aluminium angle and wood – it is articulated with wheeled drawer runners to allow smooth movement from side to side and back and forward. A fluorescent light attached to the underside of the stereoscope carriage illuminates the images

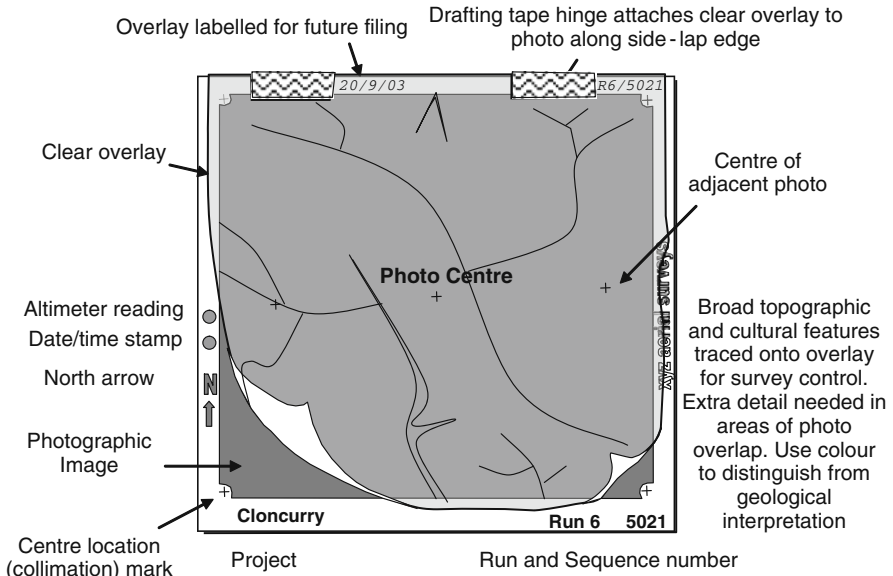

Fig. 2.7 An air photograph prepared as a base for geological mapping

- It is recommended that interpretations of the remote sensed imagery be marked on to a clear overlay.<sup>16</sup> The overlay should be attached to the top edge of the image (i.e. the upper or side lap edge of air photographs) so that it can be rolled back clear from the adjacent image and stereo viewer frame. Experience shows that drafting tape is best for attaching the overlay to the print as it will not split along the fold and can be easily removed (Fig. 2.7). When working with air photographs that have full stereo coverage (60% forward lap), it is only necessary to put overlays on every second photograph.
- With satellite stereo pairs, computer processing ensures that the right hand image is orthorectified and georeferenced (see Sects. 8.4 and 10.5 for definition of these terms) while the parallax displacements that contain information about the vertical relief of the scene are placed on the left hand image. When viewing these images, the clear overlay should be attached to the top edge of the RH image and all annotations and interpretations made on to this sheet. This means that interpreted geology will automatically be an ortho map.
- An alternative method used by some geologists is to mark observations directly onto the surface of the image using a pencil that does not damage the print and can be readily removed (e.g. a chinagraph or omnichrome pencil). However, putting

<sup>16</sup>Overlays are available in pre-cut sheets of clear to part-translucent drafting film. Clear sheets do not obscure the photo below, but are difficult to write on without special writing materials. Matt surface films readily take pencil marks but may have to be flicked out of the way when detail of the photo has to be observed.

interpretation lines on a print surface obscures the original detail of the image on which these lines were based and makes it hard to see alternative interpretations. This can make it difficult to change early interpretations.

- The overlay should be labelled with the image identification number or the run number and photo sequence number (Fig. 2.7).
- With air photographs, the centre point (sometimes called the principal point) of the photo should be located. This point lies at the intersection of lines joining special location marks which are printed in the centre of each edge of the photo (these marks are called collimation marks and are sometimes in the corner of the photo).
- Locate (by inspection) on each air photo the centre points of the adjacent photos along the flight path. This can be done because of the 60% forward lap between photos. There will thus be three points located on each photo. Transfer these points to the overlay.
- In order to position adjacent photographs so that they are exactly aligned for stereo viewing the following procedure can now be used. Place adjacent photos side by side below the stereo-viewer so that the three centre points marked on to each photo lie as nearly as possible along a single straight line (a stretched thread can make this procedure easier, as shown on Fig. 2.6). The straight line should line up with the “E–W” optical axis of the stereoscope. Looking at the photographs through the viewer, move the photos together or apart along that line so as to bring them into stereoscopic alignment. Once this is achieved, the photographs are positioned so that most<sup>17</sup> of their area of overlap is correctly aligned for stereo viewing and it should need only minimal subsequent adjustment as the field of the viewer is moved across the images.
- When working in the field in areas with complex geology and mineralization, annotations marked on to an air photo overlay can become very crowded. Many geologists overcome this by using up to three overlays, mounted separately on three sides of the photo. One overlay can then be used for showing lithologies, one for structural observations and the third for mineralisation and alteration.
- Another way of organizing information on the photo overlay when working in the field is to mark a location by means of a small pin-hole pricked through the print (Fig. 2.8). Information about that location, such as sample number, notebook reference number, GPS way point number and so on, is then written on the back of the print.

### ***2.2.7 Working with Enlarged Air Photographs***

Air photographs can be enlarged many times<sup>18</sup> and still provide a useable base map for field work. The enlargement has to be made photographically from the original film negative and only the central 60% of each photo (where distortion is

---

<sup>17</sup>It is generally impossible to exactly align all the overlap area of the photos due to edge distortions.

<sup>18</sup>Air photos enlarged up to 20 times have been successfully used as mapping bases.

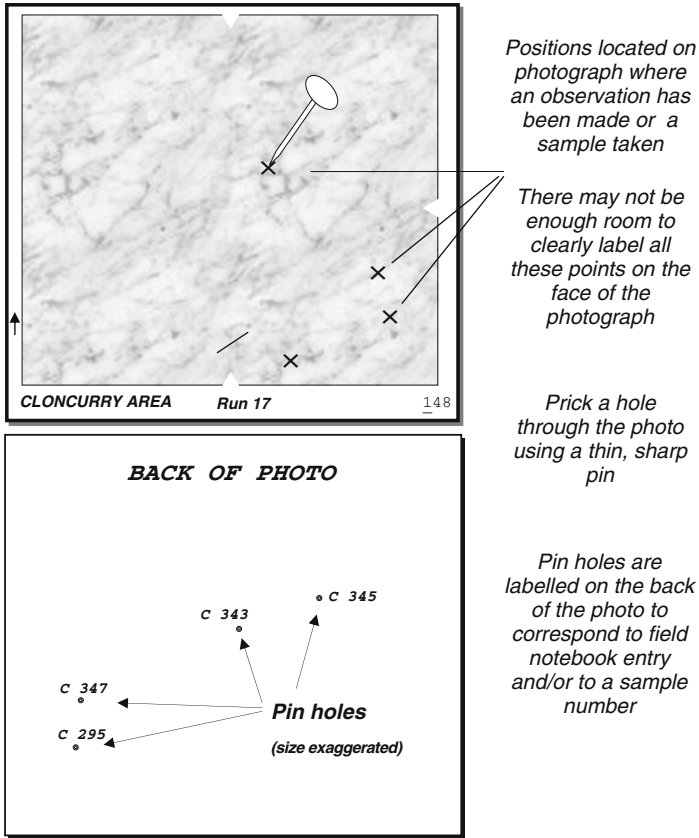
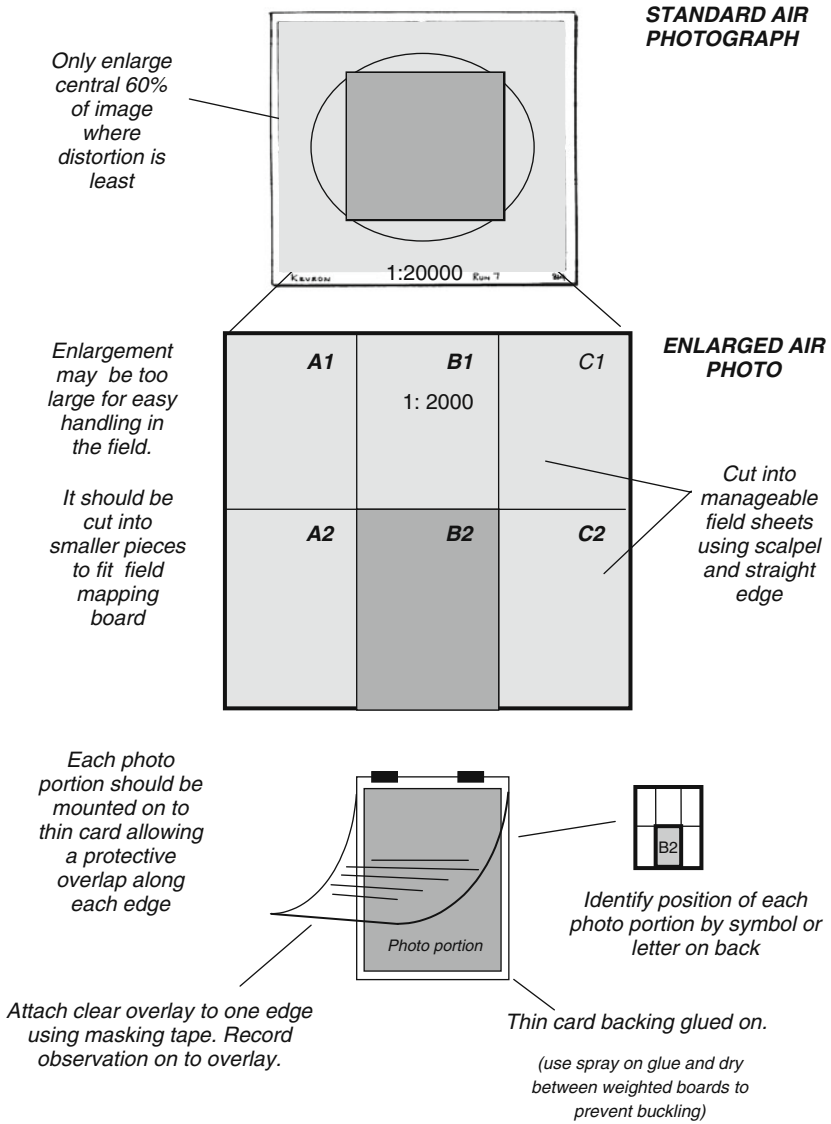

**Fig. 2.8** Using a sharp pin to transfer location points from the face to the back of a photograph. Annotating points on the back of the photo leaves the face side clear for geological interpretation.

negligible) should be used. Enlarged photos cannot be easily viewed stereoscopically so a standard-scale stereo pair should be kept handy to aid in field positioning and interpretation.

The enlarged photo will usually be too big to be handled in the field and may have to be cut into smaller pieces. Such cut-down images have to be treated with great care because mapping needs to be carried right to their edges. This is because there is no overlap with adjacent images and no protective border around each cut-down photograph. The same problem arises when working in the field with large satellite images. To overcome this problem the following procedure is recommended (Fig. 2.9):

- Cut the images into as large portions as can be conveniently handled in the field. For most geologists this is probably about 60 × 40 cm.



**Fig. 2.9** Preparing an air photo enlargement for geological mapping

- Glue each photo portion to a backing of thin card using a spray adhesive. The backing should be slightly larger than the image to protect its edges from becoming dog-eared.
- Clearly label each photo portion on the back with a code so that adjacent photo portions can be quickly identified. A matrix system using letters for columns and numbers for rows works well. The back of each photo portion should also be

marked with the scale, north arrow, original run and print number and any other relevant details about the project.

- Attach drafting film overlays to the photos in the manner described for preparing standard size prints.
- Make a field mapping clip-board out of a piece of hardboard and several spring clips.
- The board should be a few millimetres wider all round than the photos. When not in use, a second board of the same size can be used as a protective cover for the prints.

### ***2.2.8 Data Transfer to Base Map***

With air photographs, because of the scale distortion, geological boundaries plotted on an overlay do not represent an accurate map projection. Although the errors on any one photograph are not be great, if interpretations from adjacent photos are combined to make a larger map, the resulting errors can be cumulative and eventually may cause a gross distortion of true geological relationships. Ideally, the interpretation of each photo can be transferred on to an orthophoto<sup>19</sup> by matching features. Orthophotos are, however, not always available and are expensive to produce. Geological interpretation can also be plotted on to a photo-mosaic, but such mosaics also contain localized scale distortions and discontinuities. The easiest way therefore is to transfer the interpreted data from each photo overlay on to a scale-correct map base.

The ideal topographic base map for plotting photo geology should have the following features:

- The same scale as the photographs (a print can be photo enlarged or reduced if necessary);
- Sufficient topographic/cultural features (rivers, tracks, fence lines, buildings, etc.) to enable the photos to be exactly located;
- No unnecessary detail which would tend to obscure the geological information to be plotted on it;
- Availability on transparent drafting film.

Maps with these features can often be bought directly from government mapping agencies and are known as a line base. In most developed countries topographic

---

<sup>19</sup>An orthophoto is a distortion-free photographic image produced from standard air photos by computer scanning. Once in digital format the image is corrected for radial distortion and a Digital Elevation Model (DEM) is used to correct for altitude differences across the scene. The process is known as ortho rectification. An orthophoto map is an orthophoto to which metric grid coordinates and (sometimes) annotated line work identifying topographic/cultural features has been added – a process called georeferencing. For more on orthorectification and georeferencing see Chap. 10.

map data are also available in digital form. It is possible to buy these data on disc or on-line and to edit the base map required using a CAD (computer aided drafting software) system. A print-out of a line base can then be made at an appropriate scale on film or paper.

The procedures recommended for transferring geology from an air photo overlay to the line base are as follows:

- Check with the base map to see which features on the map can also be seen on the photograph. Ideal features are points such as fence corners, bends in roads, bends in rivers or river junctions, wind-pumps, buildings, etc. Trace the more important of these features on to the photo overlay. It is particularly important to pick up features near the edges of the photo where a match will need to be made with data on the adjacent photo; this is also the area where scale distortion is greatest. Fewer control points need to be identified in the photo centre. It is a good idea to use colour to distinguish this topographic/cultural detail on the overlay from lines and symbols showing the interpreted geology.
- Place the photo overlay below the base map and position its centre point by matching the selected features common to map and photograph. Mark the photo centre onto the base map. Maps showing plotted photo centres can often be bought from the same agency that sells the photographs, but such maps are designed as a guide for purchasing only and are not very accurate. Plot your own centres.
- Trace the geological interpretation on to the base map starting from the centre of the overlay. As the tracing moves out from the centre, move the overlay so as to maintain a match between overlay and line base, using the reference topographic features adjacent to the geology being traced.

There is an element of necessary fudging in this technique to achieve smooth geological boundaries. Special care has to be taken in the overlap areas between photographs. Limited scale and angular distortions will inevitably creep in, but if the above procedure is followed these errors will be small, localized, non cumulative and will not affect essential geological relationships.

## 2.3 Mapping with a Plane Table

This section describes how to make a geological map using a simple plane table. A plane table is a small horizontally-mounted mapping board used in the field so that the bearings to features of interest can be directly plotted onto a paper sheet pinned to the board.

Before the mapmaking process begins, the geologist must study the area and determine what features are to be recorded.

The plane table is a small board, generally about 50–60 cm square, mounted horizontally on a tripod and locked to face in any chosen direction. Plane tables

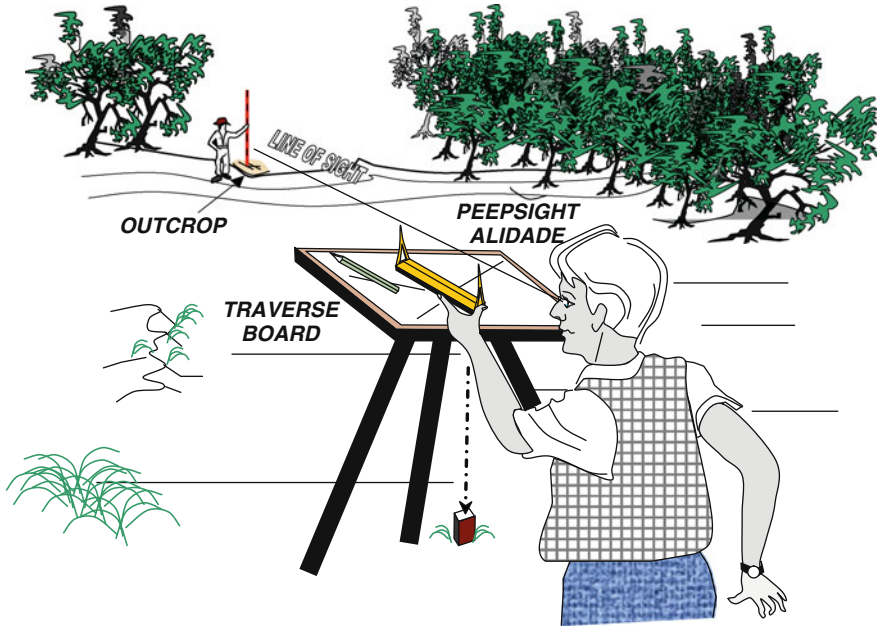

**Fig. 2.10** Detailed geological outcrop mapping using a plane table. In this example, a simple home-made peep-sight alidade is being used

(sometimes called “traverse boards”) are made especially for this job, but one can readily be made to fit on to the tripod support of a theodolite (Fig. 2.10).

The essential beginning for any survey is establishing two points in the survey area at a known distance apart and within easy sighting distance of each other (say up to 200 m). These positions will be referred to as the first and second survey points; once established using a surveyor’s tape or chain, they are marked on the ground with a peg or flagging tape, or both.

The plane table is mounted in a horizontal position directly above the first survey point and oriented with a compass so that one edge faces north. It is then locked in that position. A sheet of paper is fixed on to the table and a mark is made at some suitable place on the paper to indicate the position of the table. A sighting instrument called an alidade is then laid on the map with one edge on the marked set-up point. In the illustration of Fig. 2.10, a simple home-made alidade, called a peepsight alidade, is being used.

The alidade is rotated around the marked point so as to sight on to the second survey point. A pencil line is then drawn along the edge of the alidade, marking the bearing to the second point. Because the distance between the two points is known, the position of the second point can now be plotted on the map according to a suitable scale.

Now the lines marking the bearings to any other points of interest within the view of the observer can be marked on to the map in the same way, radiating out from the



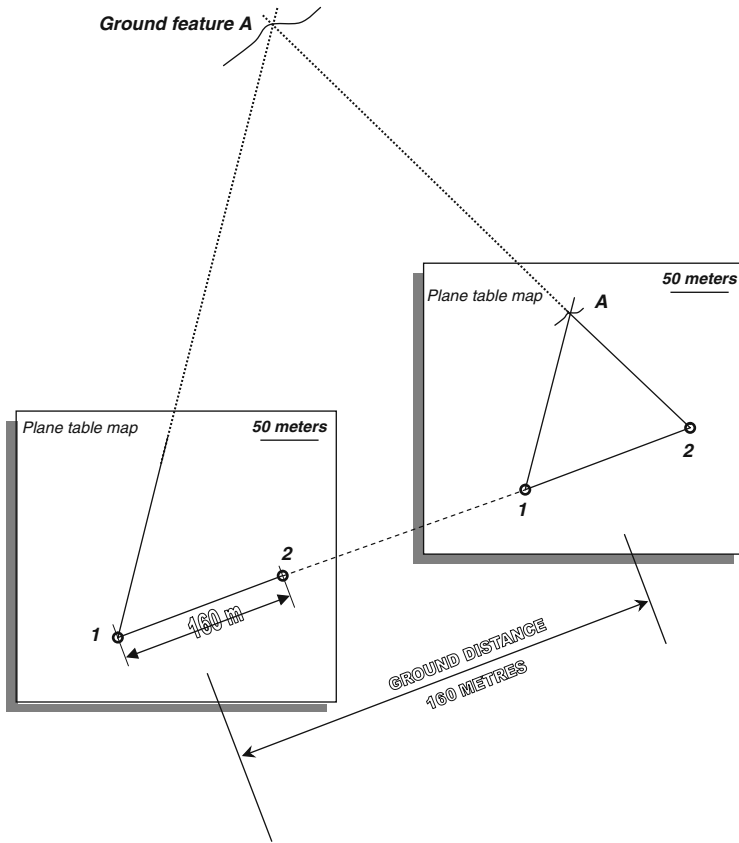

**Fig. 2.11** Positioning a point by triangulation during plane table mapping. Points 1 and 2 are at a known distance apart – in this case 160 m. By positioning the plane table over each point in turn, and taking bearings on the feature A, its map position can be established

first set-up point (Fig. 2.11). It is not necessary to measure any of these bearings with a compass. The features on which sightings are made can be geological, topographic or cultural features, or arbitrary survey points. The best technique is to sight on to a survey pole that is moved from point to point by an assistant on the instructions of the mapper – portable 2-way radios will help with this process. The assistant then identifies and labels each survey point (using a marker such as a peg or flagging tape). The identification of the bearing is also recorded on to the map.

When the bearings of as many features as required have been recorded in this way as a series of lines on the map, the plane table is then moved to a position above the second starting point. The table is then rotated around its vertical axis so that the line marking the bearing between the two starting points is back-sighted on start point one; the table is then locked in this position. Now a second set of bearing lines, radiating out from the second start position, are taken to all the features that were

identified. Where the two bearing lines on any one feature cross, that point is exactly positioned on the map – this process is known as triangulation. Any difference in relative levels between the surveyed points does not affect the accuracy of the map projection. Once a network of survey points have been established in this way, the survey can be infinitely extended in any direction by selecting any two of these points as the base line for new triangulations.

Plotting geological observations on to the survey base depends on using the exactly positioned survey points for control. In most cases these points will have been chosen on geological features and will have been put in closely where the geology is complex. With a large network of suitably positioned survey points, it is a relatively easy task to sketch in geological boundaries between the known points. In a plane table survey, it is necessary to know in advance what geological features are to be recorded and to select the survey points accordingly. Another technique is for the geologist to walk the outcrop with survey marker in hand, calling out (or using a radio transceiver) to the assistant to take the appropriate bearings and record geological data that is dictated. The technique or mix of techniques that are chosen will depend on the geologist, the assistance available, and the nature of the surveying/geological problem.

In heavily vegetated or hilly country, survey points can only be established where sighting lines are possible. Detail between the networks of triangulated points will have to be subsequently mapped in by means of a tape and compass survey.

For prospect mapping, the simple set-up described above is probably all that the geologist will need, especially as more complex survey instruments may not be available. However, more sophisticated alidades can simplify the mapping process. By sighting through the ocular of a telescopic alidade, more accurate bearings over much greater distances can be made. If the assistant carries a graduated survey staff, the interval between two sighting hairs (called stadia hairs) superimposed on the telescopic image of the staff, provide a direct measure of the distance to the staff. The position of the point can then be directly plotted on the map without the need for triangulation. This surveying process is called tacheometry. The inclination of the telescope, recorded on a built-in scale, gives the vertical angle to the plotted point, and can be used to make a contour map of the area of the survey. Modern electronic distance-measuring survey instruments, employing reflected infra-red or laser beams, can also be used for plane table map-making.

## **2.4 Mapping on a Pegged Grid**

### ***2.4.1 Requirements of the Grid***

A pegged grid consists of a regular array of pegs or stakes placed in the ground at accurately surveyed positions and used to provide quickly accessible survey control points to locate all subsequent exploration stages. The following points should be borne in mind:

- Ideally, for detailed geological mapping purposes, at least one grid peg should be visible from any point within the area to be mapped. Such grids may therefore need to be closer spaced than a grid designed solely for collection of geochemical or geophysical data. This aspect should be considered at the planning stage of the programme. In relatively open country, a grid spacing of  $80 \times 40$  m is ideal.
- The orientation of grid lines should be at a high angle to the dominant strike of the rocks, to the extent that the strike is known.
- As a general rule, grids used for mineral exploration do not have to be established with extreme accuracy – placing pegs to within a meter or so of their correct position is acceptable. All types of data collected on the grid – geology, geochemistry, geophysics, drill hole data – will still correlate. If it ever becomes important, the position of any feature can be subsequently established to whatever level of accuracy is desired.
- To prevent small surveying errors from accumulating into very large errors, the grid should be established by first surveying a base line at right angles to the proposed grid lines. Points on the base line should be surveyed in as precisely as possible using a theodolite and chain. The theodolite is then used to accurately establish the right angle bearing of the first few pegs on each cross line of the grid.<sup>20</sup> From this point, the remainder of the grid pegs can be rapidly placed by using a tape for distance and simply back-sighting to maintain a straight pegged line. Where dense vegetation or rugged topography prevents back-sighting, short cross lines can be pegged using a compass and tape. For grid lines over about 1 km long, tape and compass surveying can cause unacceptable cumulative errors, and positioning with a theodolite is recommended.
- In hilly country, the establishment of an accurate grid requires the use of slope corrections. The slope angle between the two grid positions is measured with a clinometer. To obtain the slope distance which corresponds to a given horizontal grid distance, divide the required grid distance by the cosine of the slope angle. This calculation can easily be done with a pocket calculator but since the grid spacings are fixed, a sufficiently accurate slope distance for any given slope angle can quickly be read off from a table of pre-calculated values such as Table 2.2.
- If a detailed contour map is not otherwise available, the slope angle between pegs should be recorded and used to compile a contour map of the area. Contours are essential in hilly country to understand the outcrop patterns of rock units on the map, particularly in regions of shallow dipping beds.
- Grid peg spacing in distances that are multiples of 20 m should be considered, as this allows for more even subdivisions than the more traditional multiples of 50 m.

---

<sup>20</sup>Establishing a cross line at right angles to a base line can also be done using an optical square – a hand-held sighting instrument which enables two pegs to be placed so as to form a right angle with the observer.

**Table 2.2** Table for converting slope distance into horizontal distance

Slope angles (degrees)	Horizontal distance (m)									
	5	10	20	25	40	50	60	75	80	100
	<i>Slope distance (m)</i>									
5	5.0	10.0	20.1	25.1	40.2	50.2	60.2	75.3	80.3	100.4
10	5.1	10.1	20.3	25.4	40.6	50.8	60.9	76.1	81.2	101.5
15	5.2	10.3	20.7	25.9	41.4	51.8	62.1	77.6	82.8	103.5
20	5.4	10.6	21.3	26.6	42.5	53.2	63.8	79.8	85.1	106.4
25	5.5	11.0	22.1	27.6	44.1	55.2	66.2	82.8	88.3	110.4
30	5.8	11.5	23.1	28.9	46.2	57.7	69.3	86.6	92.4	115.4
35	6.1	12.2	24.4	30.5	48.8	61.0	73.3	91.6	97.7	122.1
40	6.5	13.0	26.1	32.6	52.2	65.3	78.3	97.9	104.4	130.5
45	7.1	14.1	28.3	35.4	56.6	70.7	84.9	106.1	113.1	141.4
50	7.8	15.5	31.1	38.9	62.2	77.8	93.3	116.6	124.4	155.5
55	8.7	17.4	34.8	43.5	69.7	87.1	104.5	130.7	139.4	174.2
60	10.0	20.0	40.0	50.0	80.0	100.0	120.0	150.0	160.0	200.0

- The origin of the grid should lie well beyond the area of interest so that all grid coordinates in the area are positive whole numbers. Conventionally, the origin is placed to the southwest of the area so that all coordinates can be expressed as distances north (northing) or east (easting) of the grid origin.
- If possible, choose the origin of the grid so that easting and northing coordinates through the prospects of principal interest have dissimilar numbers. This will help to reduce potential future errors.
- Where a grid oriented N–S and E–W is required, consider using national metric grid coordinates (i.e. UTM, see Sect. 10.5). The advantage of this is that published map-based data sets can be easily tied to the local grid observations. Using national metric coordinates requires that at least one point on the ground grid is accurately positioned by survey into the national grid. Only the last four digits of the regional grid need be shown on the grid pegs.
- Clearly and permanently label grid pegs as shown in Fig. 2.12. Wooden pegs are usually cheapest and are ultimately biodegradable. For a more permanent survey consider using galvanized steel markers (fence droppers make good survey pegs). Steel pegs are essential in areas where bush fires and/or termite activity is common and the grid is required to last for more than one season.

### 2.4.2 Making the Map

Mapping is carried out on to field sheets that are generally graph paper of A3 or A4 size. The thin, shiny-surface papers of most commercially available pads of graph paper make poor field mapping sheets. If possible, use a heavyweight,

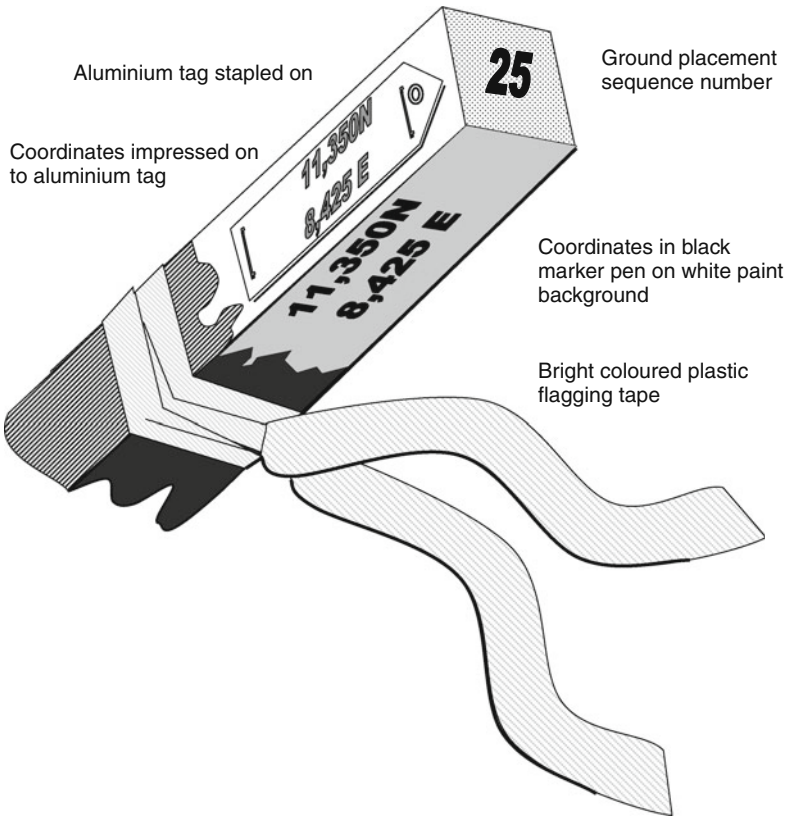
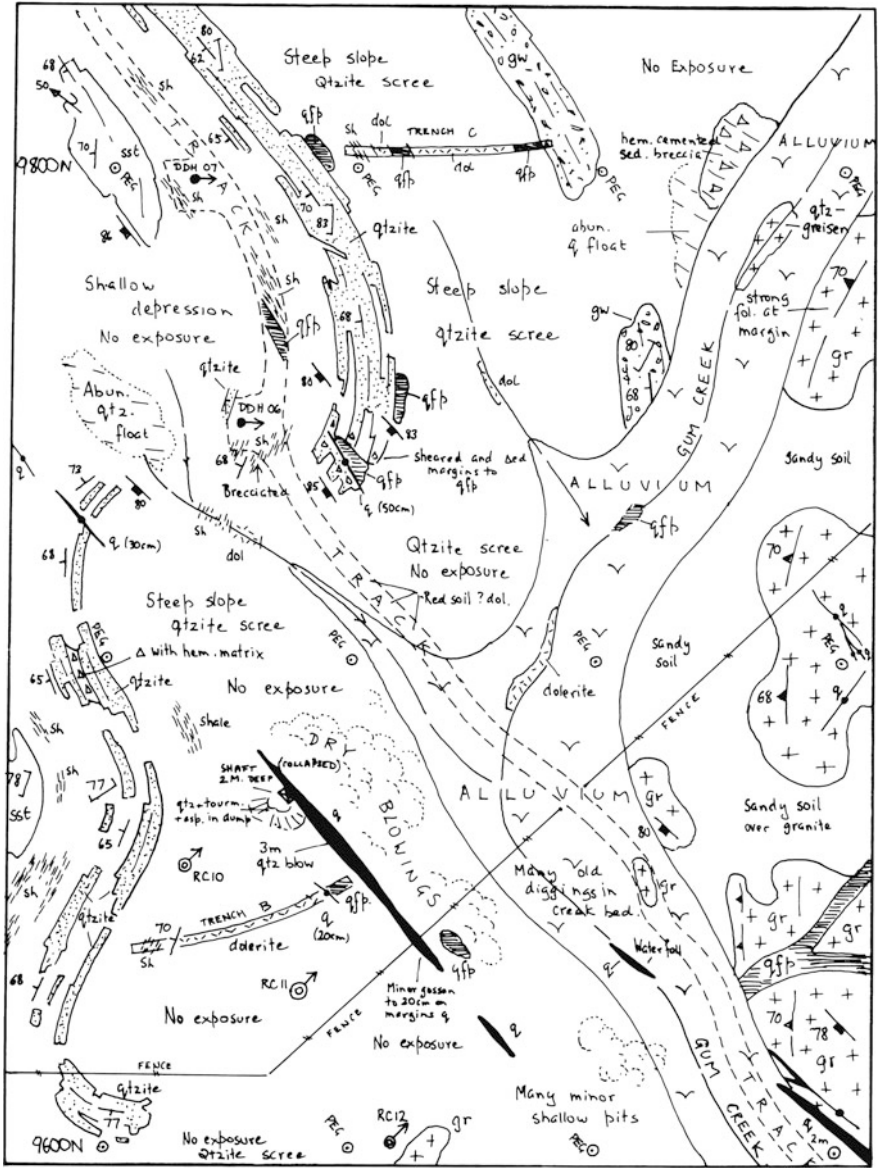

**Fig. 2.12** Recommended labelling system for grid pegs. These are short wood or steel stakes hammered into the ground at regular surveyed intervals to provide ongoing survey control for all exploration stages from geological mapping to drilling

matt-surface paper with a 1 cm ruled grid (you may have to get these specially printed). Waterproof sheets of A4 graph paper are available if mapping has to be carried out in wet conditions.

The positions of the grid pegs are marked on to the map sheets according to the scale chosen before field work commences. Field map sheets are valuable documents and, along with any field notebooks, should be carefully labelled and filed at the end of the work. Usually the area to be mapped is larger than can be covered by one field sheet. In setting up the field sheets, allow for an overlap between adjacent sheets and clearly label each sheet so that adjacent sheets can be quickly located.

As a surveying aid, at an early stage in the mapping process, it is of great value to create an extra network of location lines on the map sheet by surveying on to the map any topographic or cultural features of the area such as ridge lines, streams, tracks, fence lines, etc. that may be present. In the example shown (Fig. 2.13), the survey control provided by a 100 × 50 m pegged grid was supplemented by first surveying the stream, track, fence line, costeans and drill holes on to the map



**Fig. 2.13** An example of a 1:1,000 scale outcrop geological map of a mineral prospect in the Northern Territory of Australia. This is one of a number of adjacent field sheets. Mapping was controlled by a pegged grid on 100 × 50 m spacing

before the detail of the geology was recorded. As well as a survey control, in hilly country the position of ridge lines and drainages are necessary to complement the topographic contour information in order to understand the outcrop patterns of shallow-dipping beds.

As a general rule, the pegged grid should be regarded as a survey aid with no geological significance. Above all, the grid is not necessarily to be regarded as a predetermined set of traverse lines. In the field the geologist should follow her own ideas on the geology, and not the grid line.<sup>21</sup> If the chosen mapping strategy is to walk a traverse across strike then a traverse should be planned according to where the most productive outcrop is to be found, always bearing in mind that traverses do not have to be ruler-straight lines. For example, in many areas, often the only outcrop to be found is in stream beds, and these must feature prominently in the mapping route chosen. The important thing to try to achieve is that the amount of attention which any outcrop receives is in proportion to its geological importance, not its closeness to a grid peg.

When it comes to positioning a feature on the map, a compass bearing can be taken from the feature to the nearest grid peg. Usually, the peg will be sufficiently close so that distance from peg to feature can be measured by pacing or even by estimate, although more accurate location of the feature can be achieved by triangulation between two or more grid pegs. To plot these measurements, a protractor and scale ruler are necessary and important field mapping tools. Every point or line placed on the map does not need to be accurately surveyed in. Once a network of key points or lines has been exactly positioned, the remainder of the geological boundaries are simply sketched in, so as to preserve the correct style and relationships seen in the outcrop. This is illustrated in Fig. 2.13. On this map, the outcrop boundaries are drawn so as to reflect the characteristic shapes of outcrop observed for the different rock types: note that the quartzite outcrop shapes are well-defined and rectilinear; the sandstone outcrop shape is massive and blocky; the shale has insignificant low outcrop in narrow strike runs whilst the granite presents ovoid and somewhat amoeboid outcrop shapes.<sup>22</sup>

Observations are plotted as they are made, in pencil, on to the field map sheets with the aim of creating a complete map in the field. Structural measurements are plotted with the appropriate map symbol (using a square protractor), thus continually building up the geological picture as work progresses. There is no need to record the measurements separately in a notebook, unless they are required for subsequent structural analysis. Since the principal function of geological maps is, by definition,<sup>23</sup> to show the distribution of strike, it is in most cases (for exception, see

---

<sup>21</sup>In very dense scrub or forest, the cleared grid line often provides the only practicable traverse route. Even here, however, every effort should be made to pick up significant outcrops between the lines and to map cross-cutting access lines such as any tracks or creek sections.

<sup>22</sup>This used to be called map-makers' (or geologists') wobble and is one of the things that can distinguish a great geological map from a merely pedestrian one. This is not artistic licence: Chaos Theory describes what the geologist is doing. For each lithology, the map outline of the outcrops has a characteristic fractal dimension – a fraction somewhere between 1 and 2. The fractal number is lowest for a “smooth” outline such as the granite, and highest for a “rough” outline such as the quartzite.

<sup>23</sup>Strikes are the trace of planes on maps just as dips are their trace on sections.

below) much more useful to plot the strike and dip of measured planes on to the map than dip and dip direction.

As far as map-scale pattern and outcrop distribution is concerned, the strike is the most important measurement to make in terrain characterized by steep-dipping structures. The opposite is true where very shallow-dipping beds predominate: in such terrains, the strike can be quite variable and may have little significance, but dips tend to be more constant and have much greater control on outcrop patterns of rock units.

As the elements of the map are slowly assembled in this way, the map can be used to make predictions about the areas not yet mapped and so guide the next set of field observations, as described in Sect. 2.1.3.

## 2.5 Mapping with Tape and Compass

This technique is ideal for quickly making detailed geological maps of small areas of high interest. The logistics of the technique mean that it is particularly suited to making linear “strip” maps, such as maps of a stream section, ridge line, trench, road cutting or a line of old pits and diggings. It is also a useful technique for surveying in geological, topographic or cultural detail between the pegs of a widely spaced grid or the established traverse points of a triangulation survey. A surveyor’s steel chain or tape measure is the most accurate distance measuring devices but they can only be easily used if an assistant is available. A Hip-Chain<sup>TM</sup> is less accurate but is an acceptable alternative when time is short or there is no assistance available.

In the example shown (Fig. 2.14) a tape and compass survey has been used to map a short drainage that was identified as anomalous during a regional stream sediment survey. The map also provided an accurate base for plotting geological observations and recording the location of the sample points of detailed follow-up geochemical sampling.

The recommended procedure to make such maps is as follows:

- Start at one end of the area to be mapped. Knowing the approximate size and orientation of the area to be covered, select a suitable scale and label the field map sheet accordingly. Position the starting point of the traverse on the map.
- The assistant walks with one end of the tape to the first chosen survey point. The geologist takes a bearing on the assistant and, knowing the distance, plots the position of that point on to his or her field map sheet, using a protractor and scale ruler. Alternatively, the geologist takes a bearing on the first point and then walks to it, measuring the distance with the hip-chain. A good bearing compass such as Suunto<sup>TM</sup> or prismatic should be used.
- If the ground is very steep, a correction for the vertical distance traversed will have to be made to the tape interval. Measure the slope angle with a clinometer and, knowing the ground distance between the points, correct the position of the survey point as marked on to the map (for how to do this, see Sect. 2.4.1,



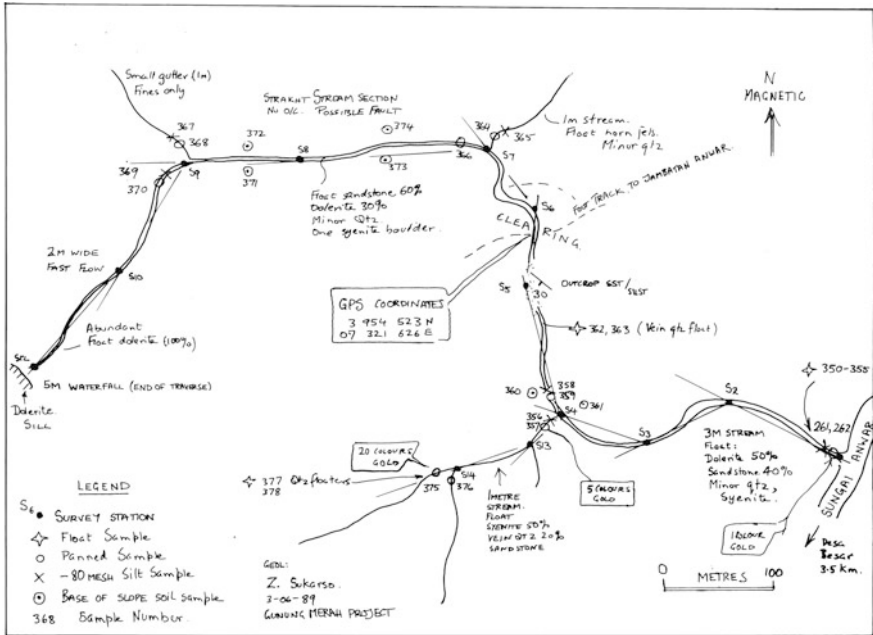

**Fig. 2.14** An example of a tape and compass map prepared during first-pass exploration of a tropical rain forest covered area. The map was used as a base to record sample positions and geological observations along a small stream during the follow-up to an initial stream sediment gold anomaly in a panned heavy mineral concentrate taken from where the stream joins the main river

- above). Leaving the tape stretched along the ground, walk to the first survey point, plotting geological observations along the traverse. Topographic details (such as bends in a river bed) can be sketched in between the known points.
- Observations of geological features a short distance away from the survey line can be recorded on the map by pacing or estimating distances, combined with a compass bearing. If necessary, very accurate positioning can be obtained by taking bearings from two known points of the traverse and triangulating, or by taking one bearing from a known point and taping the distance to the feature. It is not necessary to exactly survey in every feature that is to be recorded: once a few points are established, all other observations can usually be positioned by eye in relation to them with sufficient accuracy.
  - Repeat the process to the next survey point and so on, to complete the traverse.
  - Each surveyed point should be identified with a number on the map and marked on the ground with plastic flagging, a metal tag or a survey stake. These are exactly defined positions that can be used subsequently as a base for starting new survey/mapping traverses away from the original line of observations.
  - Make geological or geophysical observations or collect geochemical samples as mapping proceeds, locating sample points directly on the map.

## References

- Chamberlin TC (1897) Studies for students: the method of multiple working hypotheses. *J Geol* 5(8):837–848
- Popper K (1934) *The logic of scientific discovery*. Basic Books, New York, NY
- Proffett JM (2004) Geologic mapping and its use in mineral exploration. In: Muhling J, Goldfarb N, Vielreicher N, Bierlin E, Stumpfl E, Groves DI, Kenworthy S (eds) *Predictive mineral discovery under cover*. SEG 2004 extended abstracts, vol 33. University of Western Australia, Centre for Global Metallogeny, Nedlands, WA, 153–157
- Pumpelly R, Wolff JE, Dale TN (1894) *Geology of the green mountains*. USGS Memoir 23:157p
- Vearncombe J, Vearncombe S (1998) Structural data from drill core. In: Davis B, Ho SE (eds) *More meaningful sampling in the mining industry*, vol 22. Bulletin/Australian Institute of Geoscientists, Perth, WA, 67–82

# Chapter 3

## Mine Mapping

### 3.1 General

Detailed, scientific geological mine mapping began in the early years of the twentieth century with the work of Reno Sales at Butte, Montana. The mapping was done in-house for the Anaconda Copper Company, but the results were subsequently published in a monumental work (Sales, 1913). The instigation for this work was partly to solve legal disputes consequent upon the North American Apex Law of mineral ownership, but the value of quality geological mapping in the search for extensions to ore and in the development of theories on ore genesis was recognized early on.

The distribution of economic minerals within an ore deposit is a result of geological controls. If the mineral distribution cannot be directly observed, other geological effects related to that distribution often can be. Even with the most detailed assaying based on grade-control drilling and sampling, the boundaries of ore can only be adequately defined with the assistance of a geological map which shows the spatial distribution these geological features. Only by preparing accurate, detailed and up-to-date geological plans and sections of the mine can a drilling programme be effectively planned to locate extensions to ore beyond the confines of the mine openings.

Routine geological mapping of exposed rock faces within open-cut and underground mines is thus an essential part of the mine geologist's job.

### 3.2 Mapping in Open Cuts

Most basic geological data in open cuts are collected on vertical or near-vertical exposed surfaces. Even before mining, although a surface geological plan is often the starting point; the bulk of the information comes from holes drilled on vertical sections. The interpretations of mine geology and ore-body shapes made prior to mining are of necessity largely based on analysis of standard sections.<sup>1</sup>

---

<sup>1</sup>The observational data contained on standard level plans at this stage are usually an order of magnitude less dense than those of the standard mine sections.

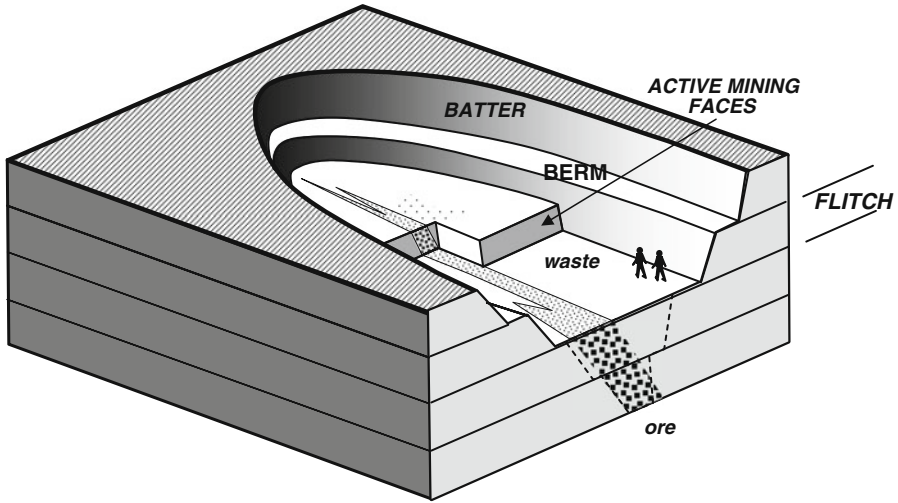

**Fig. 3.1** Block diagram of a typical open cut mine. Access ramps have been omitted

Open-cut strip mining requires removing a series of horizontal slices (called flitches) through an ore body and adjacent waste rock – a process known as flitch mining (Fig. 3.1). The high-density, vertically distributed geological and assay data therefore have to be “flipped over” and otherwise suitably extended in order to predict and control the grade distribution of the flitches.

Mapping the exposed faces in the pit should be done on to field sheets (such as graph paper). It is recommended that a detailed map be made of the vertical face, as this is the surface that can be directly observed and so will contain the highest density of information (Fig. 3.2). A scale of 1:250 is generally adequate for pit

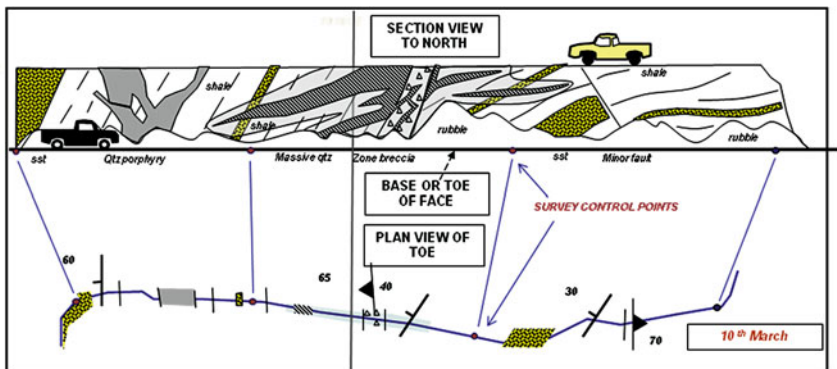

**Fig. 3.2** Mapping the active mining face of an open cut mine. The face corresponds as near as possible to a standard mine cross section. It is mapped as a section. A linear strip map of the base or toe of the face is prepared at the same time. This data is compiled onto standard cross sections and level plans (see Figs. 3.3 and 3.4)

mapping but, in areas of complexity, mapping at more detailed scales may be necessary. The actual mapping procedure is in most cases a specialized application of the tape and compass “strip mapping” procedures described in the previous chapter. In some cases, particularly where extreme complexity is encountered (and the miners allow the geologist sufficient time!), plane tabling is an effective mapping technique. The position of the mapped face relative to the mine coordinates is established by measuring a distance and bearing to some known surveyed point or points in the mine.

At the same time as making the face map, the geologist should construct a plan of the bottom (or “toe”) of the face, putting on to the plan structural measurements and the position and strike of all significant contacts or structures seen (Fig. 3.2). This plan provides a line of geological observation across the top of the level below that being currently mined. As the base of the face is usually covered in rubble, structures are plotted at the point where their down-dip projection intersects the plan.

The plan view of the toe of the face is now used with plan views from previous face positions to construct a geological map of the floor of the pit (Fig. 3.3). In constructing the level plan, the face mapping can be complemented by pit floor lithological mapping using a variety of techniques. These include:

- Mapping any outcrop, in situ rock fragments or colour changes on the pit floor.
- Using cuttings from grade-control or blast hole drilling to map lithologies.
- Digging a shallow scrape or trench across the pit floor using a bulldozer, grader or trenching machine in order to expose identifiable rock.

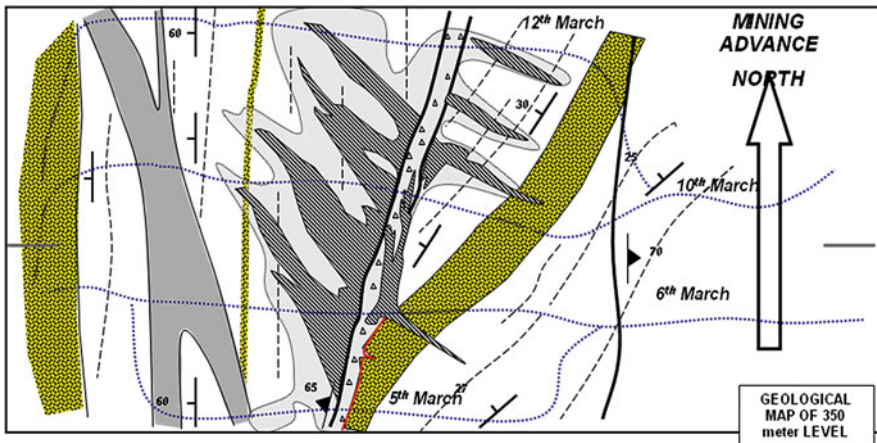

**Fig. 3.3** Geological interpretation of a mining level in an open cut mine. The map is compiled from “toe” maps of the mining advance (Fig. 3.2), from any outcrop on the pit floor, and from assay data. Extra geological information can be obtained by digging trenches or scrapes on the pit floor

Although geological plans of each level are necessary to help determine grade boundaries along the mining benches, complex geological relationships are best displayed, and are most readily interpreted, on section. The full value of face mapping will not be realized unless faces mapped on different levels can be combined to give a complete section through the ore body, as shown in Fig. 3.4. A section such as this is based on near-continuous observation, and since it can readily be combined with drill hole data, is an accurate and powerful tool for resolving details of geology and mineralization. Such composite face maps are best compiled on standard mine sections. These are the close-spaced drill sections, arranged at regular intervals along the strike of the ore body, which were used to define the ore body prior to mining. Obviously, most temporary faces exposed in a pit as mining proceeds will not exactly correspond to a mine section. However, with the progressive advance of mining, some faces will be developed which lie on such a section or close enough to it to allow projection of data on to the section. It is worth making considerable effort to ensure that these particular faces are not missed in the mapping programme.

Pits being developed in oxidized material (in some deep weathering regimes this can include the major part of the pit) can present special mapping problems. In such deposits, mining usually proceeds at a fast pace, making it difficult to gain sufficient access to a representative number of faces. In addition, weathered rocks are inherently difficult to extract meaningful geological information from, particularly when, as often happens, earth-moving equipment smears the high clay content across the face. Obviously in such circumstances, observing and recording fine detail, particularly structural detail, is often not possible. However, face mapping should still be attempted, as even a limited amount of mapping is better than none at all.

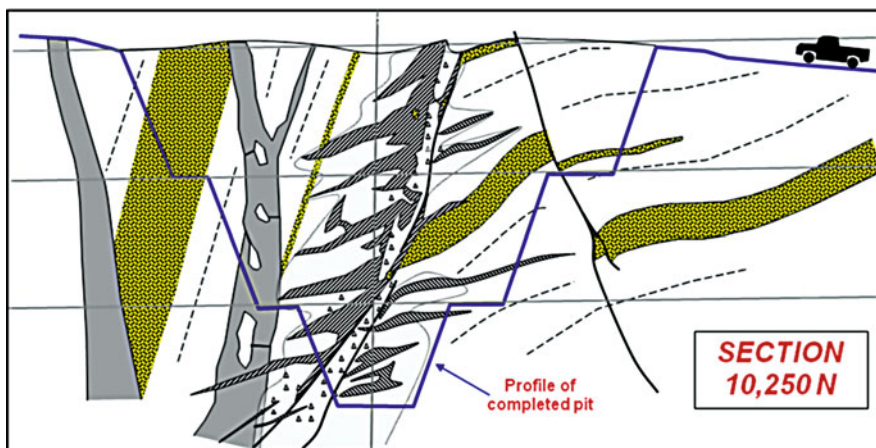

**Fig. 3.4** Geological interpretation of a standard mine section. The section is compiled from face mapping on each mine level (Fig. 3.2) and from drill hole information

Field mapping sheets do not need to be drafted or digitised but they should be carefully filed for future reference. As soon as possible the field maps should be directly transferred (photo reduce if necessary) to a digitised set of standard scale geological level plans and sections that are maintained for the ore body. Such plans and sections are usually at 1:250 or 1:500 scales. Geological information that is collected, but not compiled in this way to build up a continuous three-dimensional picture of the ore body and its host environment, is ultimately of little value.

Mapping the open cut should not just be confined to those faces developed in ore. All exposures within and adjacent to the ore body are relevant to understanding the deposit and should be routinely mapped.

Knowing what is mappable in an open cut can only come from experience. Initially, mapping may be slow and tedious until it is determined what geological features can be consistently identified and correlated from face to face and level-to-level. It is recommended that a reference set of rock-type specimens be collected to ensure consistency in description. Similarly, photographs can be taken to help build up an atlas of structural and textural features of the mine.

The sorts of geological features that might normally be mapped in an open cut (and this is not an exclusive list) are:

- visible boundaries of ore and any other significant mineralization;
- boundaries of major lithological units;
- position and orientation of major structures such as folds, faults, prominent joint sets, etc.;
- alteration patterns;
- major veins or vein sets;
- geotechnical data such as degree of fracturing,
- rock hardness, etc., as required by the engineers.

In the absence of mappable and well-defined lithological boundaries, use trend lines to show the trace of continuous features that can be observed in the rock, such as bedding planes, cleavage, joints or vein sets. Even where there are no discontinuities to place on the map as a line, continuously variable parameters such as degree of alteration, or number of veins (joints/fractures/shears) per meter, etc., can be recorded as a map annotation. Such annotations can be in words (i.e. “highly altered”), but it is usually better, if at all possible, to express the observation in a semi-quantitative way (i.e. as a number between 1 and 5; as a percentage; as a number of units per meter, and so on).

The nature of rock exposure in open cuts means that the best, and often the only, way to measure the strike and dip of planar structure is to use a geologists’ compass to sight from a distance onto the structure in the manner detailed in Appendix E. In measuring a marker bed that is exposed across more than one batter, the strike direction is easily determined from the floor of the pit by moving so as to align the bed exposed on adjacent batters, as shown in Fig. 3.5.

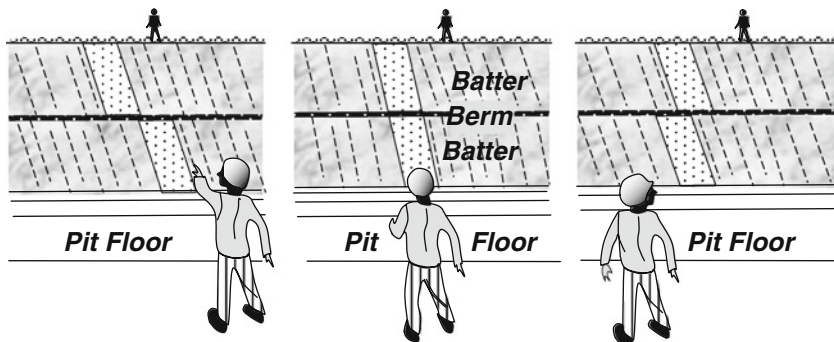

*View oblique to strike : Apparent Dip    View along strike : True Dip    View oblique to strike : Apparent Dip*

**Fig. 3.5** Judging the direction of the strike and true dip of beds exposed on the wall of an open cut. When the view is along strike, the trace of the bed on adjacent batters will line up

### 3.3 Mapping Underground Openings

Geological mapping in underground mines is normally done on to a plan or section of the opening provided by the mine surveyor. The great detail that can be observed requires mapping at very large scales, generally from 1:100 to 1:10.

Rock exposure is effectively 100%, but it is usually necessary to arrange to wash down walls and backs (the roof) before detailed features can be seen.

Rock can generally be observed on the backs and walls of the opening, and also on advancing faces. A fully detailed mapping job would therefore require that three or four maps be produced, one for each surface. Such detailed mapping is often necessary where particular complexity needs to be resolved in a critical part of an ore body. In the example illustrated, narrow, gold bearing, quartz reefs are offset by a series of faults resulting in a complex geometry which only detailed mapping of all available exposed surfaces can resolve. The face, walls and backs maps are displayed together on the same plan – informally called “exploded box” mapping (Fig. 3.6). However, this sort of detail is often unnecessary and the mine geologist will choose to map only one of the available surfaces. There is no hard rule – the choice of the reference frame on which to record observations depends on the nature of the available surfaces, the attitude of rock structures, the time available and how the map is to be used.

Flat-lying structures such as bedding, veins, etc., are best observed on vertical surfaces and recorded on section. If such features are present and are considered important, then mapping of the walls or face of the opening would be appropriate, with observations being compiled onto standard mine cross sections and/or a longitudinal section along the wall (Fig. 3.7). Conversely, steep-dipping structures are best recorded on a plan view (Fig. 3.8). In underground open stopes, virtually the only exposure available may be the roof of the opening. In this case, a map of the backs would be the obvious and indeed the only available choice. In cross-cuts,



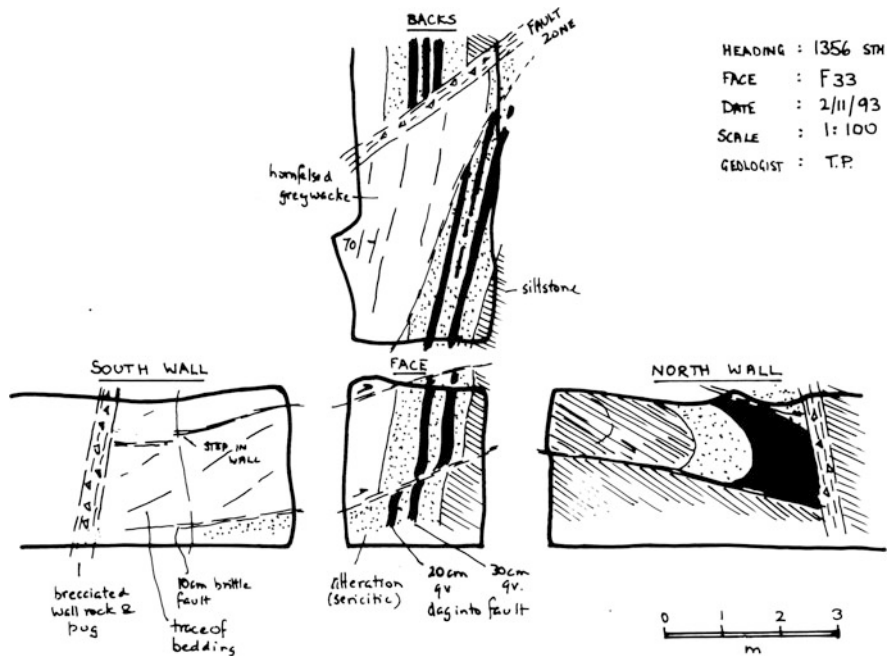

**Fig. 3.6** In underground mines with complex geology it may be necessary to make a separate map of all exposed surfaces – the roof (backs), both walls and advancing face. This is sometimes called “exploded box” mapping. The separate maps made for each advance can then be compiled on to level plans, longitudinal sections and standard mine cross sections

which are at a high angle to the dominant rock structure, there would be little point in mapping the advancing face of an opening as this would lie parallel to the structure. A map of the wall and backs is indicated. However, in drives running along the dominant strike, the advancing face will usually give the most effective cross-section view of the structures (Fig. 3.7).

Another consideration in the choice of a mapping frame is the type of plans that are required for mine planning purposes. For example, geological interpretation in a mine is often based on underground or surface drilling, and it is necessary to map geological data in such a fashion that they can be readily compiled, with a minimum of projection or manipulation, on to the drill sections. An example of mapping which is compiled on to a drill section in this way is shown in Fig. 3.7.

Clearly, mapping of shafts or other essentially vertical openings will have to be done on to a section.

A good compromise, often adopted for mine mapping where steep-dipping structures predominate, is to project rock structures seen on walls and backs on to a single level plan located at about waist height above the floor (Fig. 3.8). This is typically the height of the level plan produced by the mine surveyor, and also the height of any channel samples that might be collected for assay along the walls of a cross-cut. The

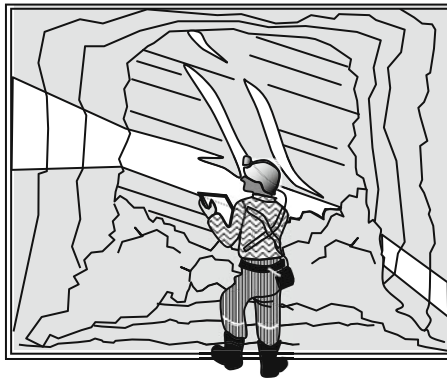

Geologist mapping a development heading in ore. After each blast, miners remove the ore then bar down the roof and walls to make safe. The geologist hoses down the rock, measures the face advance with a tape, then maps face and walls at 1:25 scale. A portable, rechargeable flood light illuminates the scene.

(a)

3 LEVEL : 10W DEVELOPMENT HEADING IN ORE : 10,224-3 NORTH  
W WALL                      FACE                      E WALL



Met foltn. 30°/02      Qtz+alb+by Alt. selvage      Qtz vein 25°/096      10cm buggy cheer 70°/155

GEOLOGIST : S. RYAN    DATE : 14/03/93    SAMPLER : M. Kozinski    GEOLOGY SHEET    SCALE 1:25

(b)

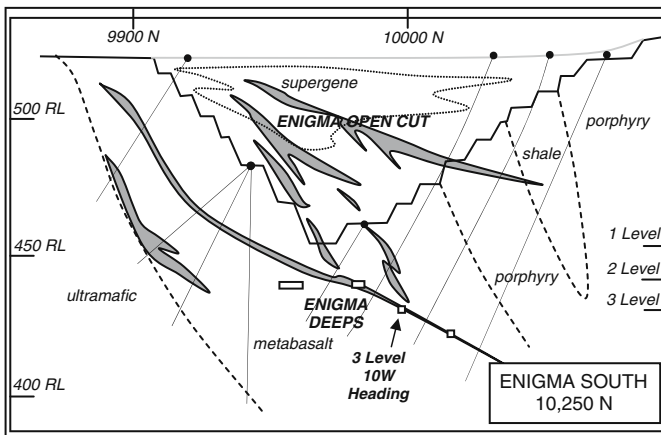

(c)

**Fig. 3.7** Shallow dipping structures are best mapped where they intersect the wall or advancing face of the opening. In the example shown, mapping has been compiled along with surface drill hole data on to a standard mine cross-section

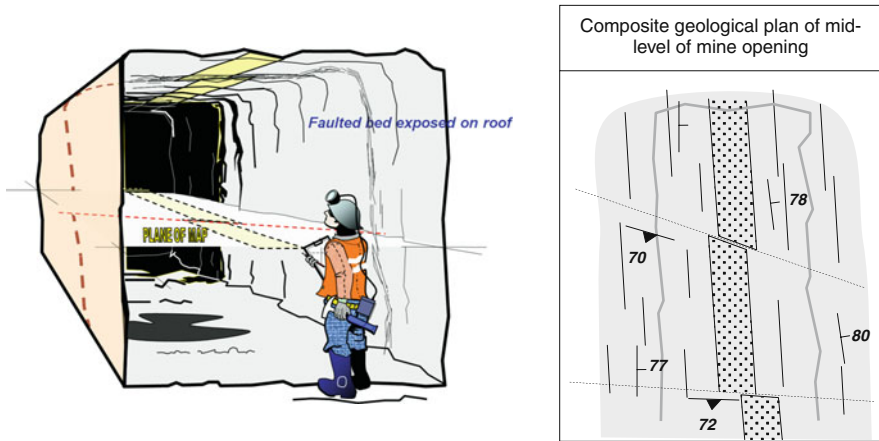

**Fig. 3.8** Steep dipping structure is best mapped in plan view. In this example, structures seen on the walls and roof of the mine are projected down-dip and down-plunge onto a single composite map at around the mid-point of the level. The resulting map will usually cover an area that is wider than the opening. This type of mapping would not be appropriate for very complex structures, for which “exploded box” mapping is more appropriate (Fig. 3.6)

geological map compiled in this way is thus a composite of observations made from all available surfaces; the data is nowhere projected more than a few metres on to the map plane, and is exactly located along both walls. For most geological mapping purposes, but particularly for cross-cuts, such a map is sufficiently accurate.

A point to bear in mind is that by universal convention geological maps show geology as if viewed from above. Care must be taken when projecting geology seen on the backs (which are naturally viewed from below) on to such a plan, as the different viewpoint causes a mirror image change in angular relationships. Folds with an “S” profile (for example) when viewed from below become “Z” profile folds on the geology map. Beds displaced by a fault in a left-lateral (or sinistral) sense when viewed from below are shown with a right-lateral (dextral) displacement on the map (Fig. 3.8). Mine geologists must learn to mentally “flip over” the geology they are looking at before plotting it on to their maps.

Whatever mapping choice is adopted, it is inevitable that many observed relationships will be seen which cannot be shown on the map. If considered significant, these can be recorded using detailed sketches, or separate maps and sections, drawn to the side of the main map and keyed to it with a line or arrow.

Although compasses work well underground,<sup>2</sup> the nature of underground rock exposure means that it is seldom possible to measure structures directly by laying a compass on the structure. The best way to measure the strike of a planar structure is

<sup>2</sup> But beware of adjacent iron objects that might affect the compass needle – there can be a lot of these in the typical underground mine.

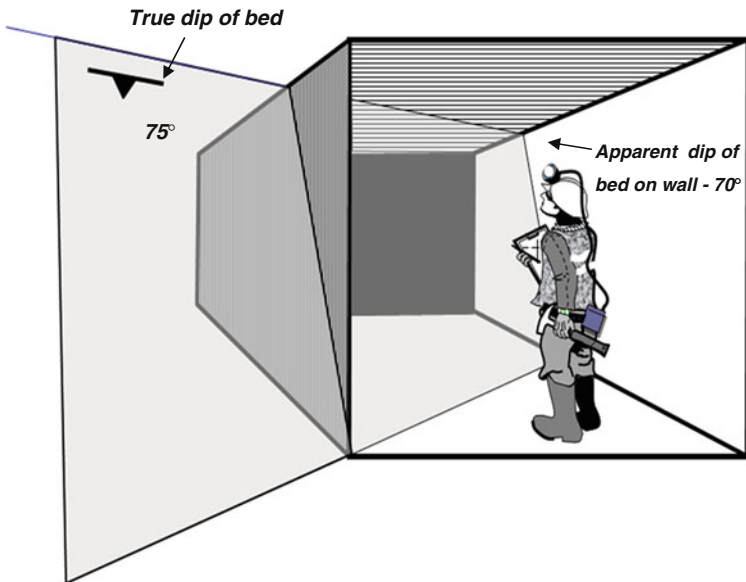

**Fig. 3.9** The trace of a planar surface on the wall of a mine opening generally represents the apparent dip, not the true dip of the surface. To obtain the true dip, it is necessary to locate the surface on both walls of the opening so that a sighting can be made along strike

to take a bearing between the points where the structure is intersected by the walls of the mine opening. The intersection of a planar structure with a vertical mine surface is only a true dip if the structure is at right angles to the wall. In the general case, intersections seen on mine walls are apparent dips. To obtain a true dip, it is necessary to sight the compass along the strike bearing (Fig. 3.9).

### 3.4 Safety in Mines

Mines are one of the most dangerous work environments that any geologist can find themselves in. To name just a few hazards, there is the ever present danger of rock falls, of being run over by heavy mine machinery or of falling into holes or over steep rock faces. To maximise safety, the geologist should keep the following rules at the forefront of his mind at all times:

- Make sure that a suitable responsible person (shift boss, mine foreman, immediate supervisor, etc...) knows where and when you are working in the mine. There is usually some sort of tagging system for entering and leaving an underground mine area. Use it religiously: this is vital for your safety.
- Familiarise yourself with all mine safety rules and procedures and follow them.

- A geologist needs to get close to a rock to see structure or details of mineralisation, but having one land from above on top of your head is much too close. Do not approach any steep or overhanging rock face without first checking it for safety. If in doubt keep well clear.
- In open cut mines steep batters can collapse with little warning. Dangerous ground is usually marked by small rock slips or by cracks opening on the berms at the head of the face. Consult with mine engineers about potentially dangerous ground. Faces that have been stable for many months or years are unlikely to collapse just because you are underneath them – but beware all rock faces after heavy rain or if there has been any recent digging or blasting or movement of heavy equipment nearby.
- In underground mines, new mine advances generally need to be barred down and perhaps secured with rock bolts or steel mesh before it is safe for anyone to enter. Check with the mine foreman before entry to such areas.
- In open cut mines keep well clear of heavy earth moving machinery – the drivers of these units have almost zero visibility for anything close to them or behind them or indeed for anything as small as a human being – even if they are clothed in fluorescent orange, jumping up and down and waving their arms about. When mapping active mining areas wait till the coast is clear before approaching the face – not all areas of a mine are worked at the same time: shift changes or meal breaks can often leave the mine area clear for periods long enough for the geologist to get close to the active faces in order to carry out her job.
- Wear safety gear. This includes hard hats, safety glasses, steel-capped boots, heavy duty coveralls and brightly coloured or reflective clothing.

## Reference

Sales RH (1913) Ore deposits at Butte, Montana. *Trans Am Inst Min Eng* 46:1523–1626

# Chapter 4

## Trenching and Underground Development

### 4.1 Preamble

Pits and trenches, or to use the old Cornish mining term, costeans, can be a quick and cheap way of obtaining lithological, structural and assay information in areas of shallow cover. Underground development, although neither quick nor cheap, has also been successfully employed in exploration programmes to gain direct access to mineralised rocks for detailed mapping and collection of bulk samples for assay or metallurgical studies.

### 4.2 Pitting and Trenching

Pitting is usually employed to test shallow, extensive, flat-lying bodies of mineralization. An ideal example of this would be a buried heavy mineral placer. The main advantage of pitting over a pattern-drill programme on the same deposit is that pits are capable of providing a very large volume sample. Large sample sizes are necessary to overcome problems of variable grade distribution, which are a characteristic feature of such deposits.

Trenches are usually employed to expose steep dipping bedrock buried below shallow overburden, and are normally dug across the strike of the rocks or mineral zone being tested. Trenches are an excellent adjunct to RAB or RC drilling programmes, where the structural data from trench mapping are needed to complement the lithological information obtained from the drill cuttings.

In some cases, it may be possible to completely strip shallow unconsolidated overburden to expose large areas of bedrock. This is done by bulldozing and/or by sluicing with high-pressure water hoses. The bedrock can then be mapped and sampled in great detail. Since the process is environmentally destructive, and rehabilitation would be expensive, extensive stripping would normally only be attempted when a prospective mineralized zone had been defined, and special sampling/geological problems were present that needed this kind of 100% exposure for their resolution.

Pits and trenches can be dug by bulldozer, by excavator, by back-hoe or even by hand. Excavators and back-hoes are generally much quicker, cheaper and environmentally less damaging than bulldozers, and because of this are nowadays usually the preferred options for costeaning. A large excavator can match a bulldozer in its power to dig rock. Back-hoes are relatively light machines suitable for digging small pits or narrow trenches. Back-hoe trenches are difficult or impossible to enter and back-hoes are really more of a geochemical sampling tool than a geological tool. When digging a trench, an excavator that can dig a trench of at least 1 m in width and that is capable of penetrating a minimum of 1 m into recognizable bedrock should be used. It is very hard to observe details of geology on the walls of trenches that are smaller than this. Continuous trenching machines,<sup>1</sup> which can rapidly cut a narrow (around 20 cm) trench to 1–2 m depth in soft material, have also been used in exploration (and grade-control sampling in the soft weathered material of some open cuts) for providing a continuous geochemical sample. These trenches are generally of little use for anything other than basic lithological mapping.

Hand-dug pits and trenches are a valid option in places where power excavation equipment cannot be brought to a remote site, and abundant cheap labour is available. In remote and rugged tropical areas, contour trails/trenches have been successfully employed in order to locate the source of anomalous float boulders or stream sediment geochemical anomalies. These trenches are long continuous notches, or incised tracks, cut along the contours of steep slopes. They can expose narrow strips of weathered bedrock along their inside edge. The exposed bedrock can be geologically mapped and channel sampled. The trails provide convenient access to the property and they are readily surveyed using a tape and compass. Contour trenches cause less environmental damage than trenches that run across the slope since in high rainfall areas the latter tend to become drainage channels that focus erosion.

### 4.3 Underground Development

Because of the expense and time involved, this option would only be considered in mineral exploration if three requirements are met:

1. The prospect must have a very good chance of hosting a profitable ore body.
2. The project is not suitable for testing by drilling. This can happen where the highly variable nature of metal distribution requires a large sample to be taken so that a true grade can be determined. It can also happen because the nature of the property (remote, very rugged, lack of access) means that large drill rigs cannot be brought to site or set up on level drill platforms.
3. There is access to underground mining expertise and equipment.

---

<sup>1</sup>Usually adapted from machines designed to dig trenches for shallow pipes and drains.

In the special conditions obtaining in the Eastern Goldfields of Western Australia, gold exploration projects have in the past been explored by shaft sinking and development on several underground levels. Contract miners are employed to do this in a process known as “tributing”. The miners pay for their efforts by keeping any gold they find, less a small proportion paid as “tribute” to the property owners. The owners of the property in their turn get underground access to map and sample the mineralisation. Should a company-scale mine be defined, the end of the contract period sees the right to mine revert to the owners.

Where steep dipping veins or zones of mineralisation occur in regions of strong relief, driving short horizontal adits at several levels from the surface can provide relatively easy access the mineralisation on several levels.

## 4.4 Safety and Logistics in Trenching

When digging a trench, attention to the following points will make subsequent mapping and sampling much safer and more convenient.

- Cut back both sides of the top of the trench for one bucket width and to a depth of 50–100 cm as shown in Fig. 4.1. This prevents loose unconsolidated surface material from falling into the trench (and on to the head of any geologist below!).
- Stack all topsoil and any loose surface material from the trench on one side of the opening; stack all bedrock material to the other side. This facilitates making a quick assessment of the trench material from the bedrock spoil heaps and will permit a bulk sample to be taken if required. When re-filling the trench (a normal environmental requirement) the spoil should be replaced in reverse order so that the topsoil is preserved on top.
- If the trench is deep (i.e. cannot be easily climbed into or out of) and more than 50 m long, provide an access ramp at its midpoint.
- Most trench wall collapses take place in the first few hours after digging or else after heavy rain. With deep trenches, it is therefore advisable to leave them for at least 24 h before entering and not to enter them immediately after rain.
- In any case, never enter a deep trench unless accompanied by another person who should remain outside the trench and be ready to provide assistance if necessary.
- Before entering any trench, but particularly an old one, walk it out along the surface to check for incipient wall cave-ins. If in any doubt, do not enter! There is generally plenty of information to be obtained from the spoil heaps along the trench edge; the walls of old trenches are often covered in grunge anyway and certainly not worth risking one’s life for.



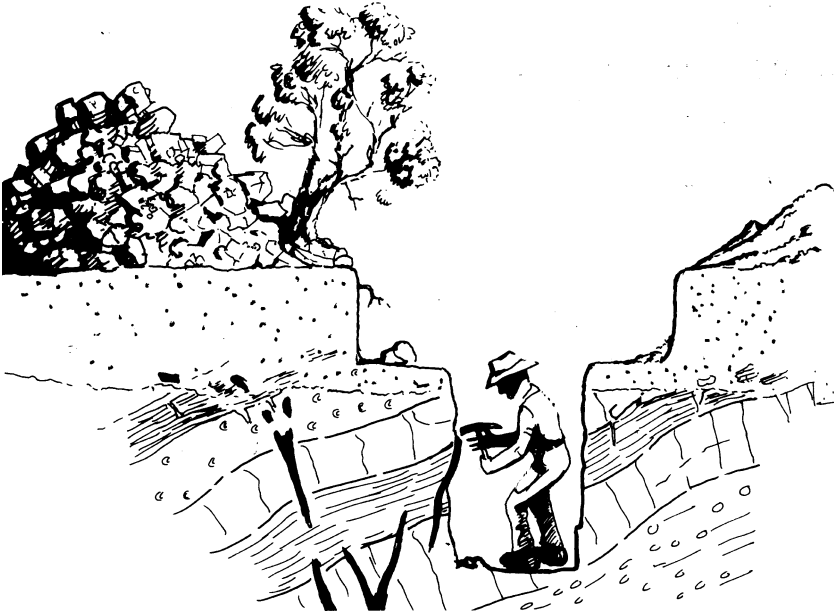

**Fig. 4.1** The ideal profile of an excavator trench. Put excavated topsoil on one side of trench, bed rock spoil on the other. Stepping back the sides of the trench as shown will makes it much safer to enter

## 4.5 Geological Mapping

Trenches should be geologically mapped. To make the map, the following procedure has been found useful:

- Drive a peg into the ground at one end of the trench and run a tape measure from there along the trench floor.
- Using the tape, mark and number the wall of the trench with spray paint every two metres. If the floor of the trench is sloping, a clinometer will have to be used to calculate slope corrections before marking the walls.
- Scales from 1:50 to 1:500 are appropriate for trench mapping.
- Shallow trenches are best mapped in plan view, with information seen on the walls of the trench projected on to plan (see Fig. 4.2). The strike of individual features which traverse the trench can be determined by their position on the two walls.
- Where a good vertical profile can be seen in the trench wall, make a vertical plan of the wall, as well as a horizontal plan (see Fig. 4.3).

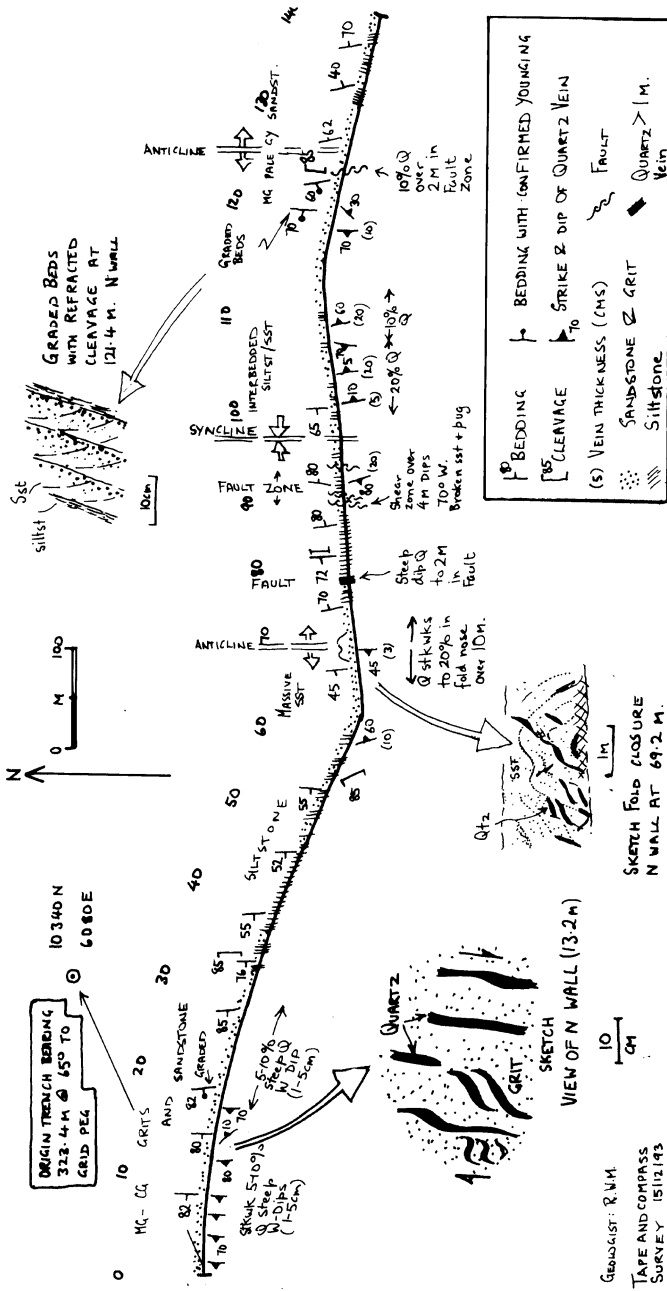

Fig. 4.2 An example of 1:500 scale geological mapping of a shallow excavator trench. The trench tests gold bearing quartz veins in steep dipping and deformed Proterozoic metasediments

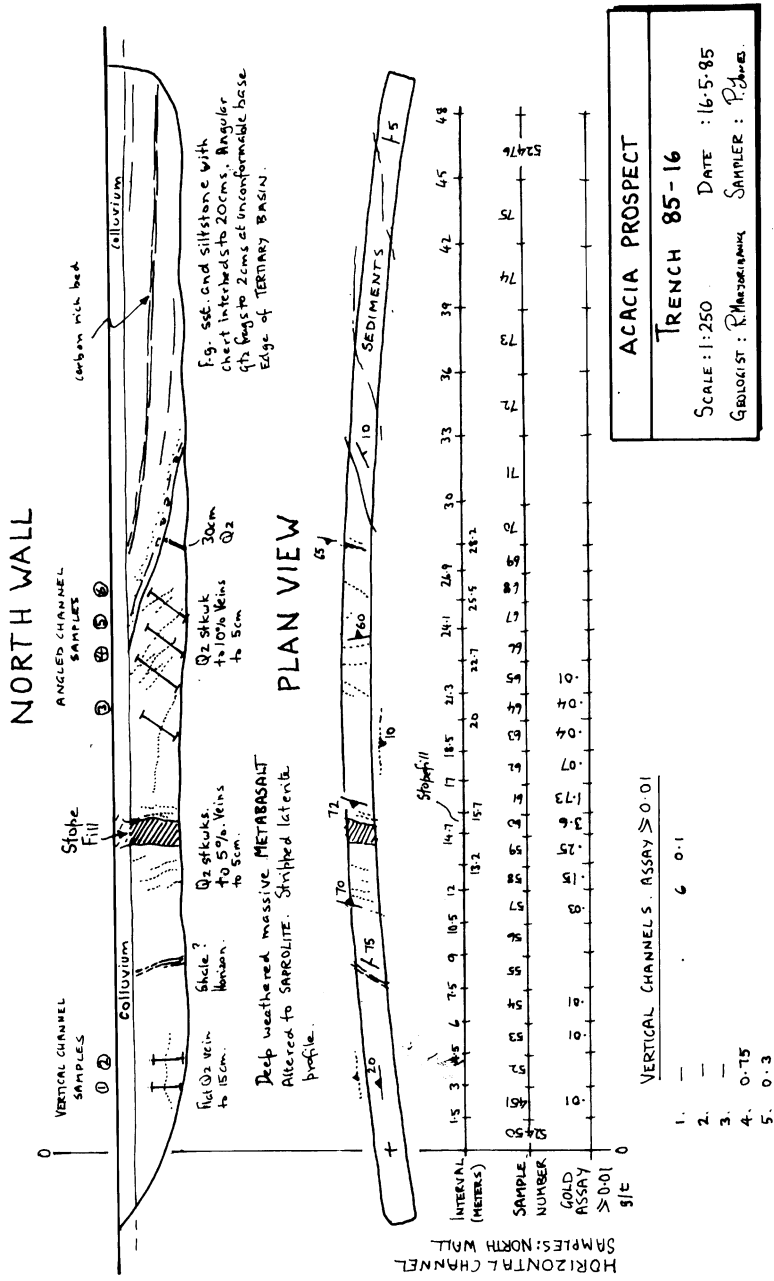

Fig. 4.3 An example of 1:250 scale geological mapping of a relatively deep excavator trench. The trench, dug in deeply weathered Archaean metabasalt overlain by Tertiary sediments, tests a surface gold soil anomaly. It unexpectedly encountered a thin coal seam and some old mine workings

## 4.6 Geochemical Sampling

Geochemical sampling of a trench involves taking a number of chip channels along it. The procedure for collecting the sample will be described in some detail as it is the same as for sampling any continuous rock exposure such as an outcrop, or the walls of an open-cut or underground mine (see also Sect. 9.12).

Intervals for sampling should be marked out by the geologist on the exposed rock and can be subsequently collected by a field technician. Sample intervals should be chosen to reflect natural geological boundaries that are considered to be mineralization controls.

Where mineralized features are steep-dipping, the appropriate sample is a horizontal channel along the trench wall (or floor, if that is where the best outcrop is). Where mineralized features are flat-lying, channel samples should be vertical. Where there is no certainty as to the attitude of mineralized zones, a sample consisting of both horizontal and vertical channels, composited over selected horizontal intervals, should be used.

Soft materials can be sampled with a geology hammer or chisel, but there is a danger that the harder bands (such as silicification) might be undersampled, and soft, easily collected material oversampled. In general, a good rock-chip channel sample can only be collected with the help of a jackhammer or rock saw.

Hand-held, electric-powered, diamond saws allow a continuous channel to be cut in the rock. The best technique is to cut out the sample using two angled cuts in the form of a V. Alternatively, two parallel cuts can be made and the rock subsequently broken free with a chisel. Diamond saws produce an excellent sample of even size, but the procedure is slow and expensive, and would only normally be used for sampling mineralized intervals. The use of a rock saw is more indicated for sampling in underground mines than for trench sampling.

Small, electric jack-hammers are available which are powered by a portable petrol generator; these are a relatively cheap and quick way of sampling most rocks and are an ideal tool for trench sampling.

A recommended procedure which has been found useful for sampling a trench is as follows:

- Cut a continuous chip channel sample along the trench. The maximum size of the fragments should be around 50 mm. Any overlarge pieces will have to be broken with a hand-held hammer and the over break discarded.
- Lay a canvas sheet along the bottom of the trench to collect the sample (Fig. 4.4).
- The sample volume is hard to control and will usually be too great for easy bagging. It must therefore be split to a smaller representative portion (say 5–10 kg) before it can be sent for assay. If the rock fragments are sufficiently small, this can be done using a riffle splitter. However, operating a splitter in the restricted area of a trench floor can be difficult, and cleaning the splitter between each sample is tedious and time consuming.
- An effective and less labour-intensive way of collecting a split for assay is to homogenize the sample by rolling it once or twice in the canvas tarpaulin on



**Fig. 4.4** Collecting a continuous chip-channel sample from a trench wall. The sampler is using a small electric jackhammer powered by a portable generator. The broken rock falls onto a tarpaulin laid along the trench floor. The same technique could be used for sampling any hard rock exposure in the field or in a mine

which it was collected, so as to form a long even pile of broken rock. The action is somewhat similar to rolling a cigarette but unlike a cigarette requires at least two people. A section of lengthways-cut 100–150 mm poly-pipe is then laid alongside the rock pile and by rolling rock and pipe together in the tarpaulin once more, the split pipe is filled with a portion of the broken rock pile. The contents of the half poly-pipe section can then be easily slid into a sample bag (Fig. 4.5)



**Fig. 4.5** Splitting a sample for assay from an even row of small rock fragments on the ground. The rock fragments lie on a tarpaulin; a halved length of 100 mm poly pipe is laid along the row and rocks and pipe are rolled together in the tarpaulin. Rock in the pipe is then slid into a sample bag

## 4.7 Examples of Successful Exploration Programmes

Few histories of exploration programmes, even those that discover ore, are ever adequately written up. This is a pity, because hindsight can show where the critical decisions were made by the explorationist, both those that led to success and those which added to the cost and inefficiency of the exploration process. The following examples are all of successful exploration projects about which the author has some personal knowledge.

1. In 1985, a geologist was contracted by Coolgardie Gold N.L. to make a detailed geological outcrop map of the Coolgardie district in the Archaean age Yilgarn craton of Western Australia. In a small valley with no outcrop, the geologist realised that a series of low grassy mounds were the spoil from regularly-spaced back-hoe pits that had been dug many years earlier in the course of an unsuccessful search for placer gold. Each pit had been dug to the base of the alluvium (1–3 m), and along with river gravel had brought up samples of bedrock to surface. This was a distinctive quartz gabbro that the geologist knew was a favoured host rock for gold mineralisation elsewhere in the district. By sampling the bedrock in the spoil heaps, an anomalous gold zone was quickly outlined. This was then defined by an extensive program of shallow excavator trenching. After evaluation RC drilling, the prospect became the profitable Greenfields open cut gold mine (Keele and Shelton, 1990). Prospect and mine were named in memory of the pleasant valley, filled with spring wild flowers at the time of discovery, which disappeared below the open cut and waste dumps of the mine.

2. In 1985, RGC Exploration discovered the Lucky Draw gold mineralisation, near Burruga in the Australian state of New South Wales. The mineralisation occurred within a stratabound iron-rich skarn in poorly-exposed metasediments of Ordovician age. Initial diamond drilling with inclined holes showed that the rocks had a dominant shallow-dipping metamorphic fabric. On the basis of this observation, it was decided that all future holes should be vertical. Many drill holes later, it became apparent that high grade gold intercepts could not be easily correlated. A number of excavator trenches were then dug across the prospect to expose the shallow bedrock and give a better idea of the structure. Trench mapping showed that the flat-lying fabric was a late cleavage which lay at a high angle to sub-vertical bedding surfaces. Drilling was then resumed using angle holes. A rational model for gold mineralisation soon emerged. Lucky Draw subsequently became a successful open cut gold mine.
3. In 1995, Newcrest Mining was exploring for gold and copper in the Neogene magmatic arc of Halmahera Island, Indonesia. Because of recent ash and colluvial cover, outcrop was limited. Along the bed of a small stream and flanks of a nearby ridge line, prospecting located abundant float boulders of epithermal quartz, some yielding high gold assays. A series of hand-dug trenches across the slope above these occurrences exposed (sub) outcrop of low-sulphidation epithermal quartz veining with a strike of over 300 m and widths to 30 m (Carlile et al., 1998). Once the extent of the surface outcrop had been defined by trenching, an extensive diamond drilling program proved an open pit resource of 0.99 Mt at 27 g/t gold and 38 g/t Ag (Oldberg et al., 1999). This became the highly profitable Gosowong mine. Gosowong is now mined out, but through persistent ongoing exploration in the surrounding district, Newcrest has located a number of other similar high grade gold deposits, some of which (e.g. Kencana, Toguraci) are currently being mined.
4. During 1999, in the remote, jungle covered eastern mountains of Burma, the Canadian company Ivanhoe Limited, following up gold anomalies from regional prospecting and geochemistry, located the Modi Taung prospect – a 4.5 km long zone of steep-dipping mesothermal quartz veins that carry bonanza gold values (Mitchell et al., 2004). The veins are hosted by cleaved mudstone of Mesozoic age. Because of the difficulty of diamond drilling in such remote and rugged terrain, and the extreme variability of gold distribution within the veins, it was decided to explore the prospect by means of a series of adits driven from different levels of the adjacent slopes. A total of 5 km of underground development allowed detailed mapping of the veins and the collection of continuous channel samples from the advancing faces and walls of drives in ore. Although the exploration was successful in defining a potentially profitable company mine, Ivanhoe was eventually forced to withdraw for non technical reasons.

## References

- Carlile JC, Davey GR, Kadir I, Langmead RP, Rafferty WJ (1998) Discovery and exploration of the Gosowong epithermal gold deposit, Halmahera Island, Indonesia. *J Geochem Explor* 60:207–227

- Keele RA, Shelton MC (1990) Greenfields gold deposit, Coolgardie. In: Hughes FE (ed) *Geology of the mineral deposits of Australia and Papua New Guinea*. Australasian Institute of Mining and Metallurgy, Melbourne, 463–466
- Mitchell AHG, Ausa CA, Deiparine L, Hlaing T, Htay N, Khine A (2004) The Modi Taung-Nankwe gold district, slate belt, central Myanmar: Mesothermal veins in a Mesozoic orogen. *J Asian Earth Sci* 23:321–341
- Oldberg DJ, Rayner J, Langmead RP, Coote JAR (1999) Geology of the Gosowong epithermal gold deposit, Halmahera, Indonesia. In: *Pacrim '99 conference papers*, Bali, Indonesia, 179–185.



## Chapter 5

# Drilling: A General Discussion the Importance of Drilling

Drilling is one of the most important, and can be the most expensive, of all mineral exploration procedures. In almost all cases, it is drilling that locates and defines economic mineralization, and drilling provides the ultimate test for all the ideas, theories and predictions that are generated in the preceding prospect generation and target generation phases of the exploration process.

In any exploration group, the percentage of the budget that is put into drilling worthwhile targeted<sup>1</sup> holes provides a measure of the efficiency of that group. To use management school jargon, the amount of targeted drilling is the key performance indicator (KPI) of an exploration group. Many well-managed and successful exploration companies believe that, averaged over a period of time, at least 40% of their exploration dollars should be spent on drilling targeted holes. The large amount of space in this book devoted to drilling reflects the supreme importance of this phase of exploration.

### 5.1 Types of Drilling

There are a large number of different drilling techniques. This book does not attempt to describe them all, but focuses instead on the three basic types that are most commonly used in mineral exploration. In order of increasing cost, these are auger drilling, rotary percussion drilling and diamond drilling (see Figs. 5.1, 5.2 and Table 5.1). A detailed discussion of these drilling techniques will be found in Chaps. 6 and 7.

---

<sup>1</sup>The term “targeted hole” is used here to refer to holes drilled on defined prospects where there is expectation of intersecting economic mineralization, as distinct from holes which are drilled primarily to increase geological or geochemical background knowledge.

**Fig. 5.1** Simple drills for collecting sub-surface geochemical samples

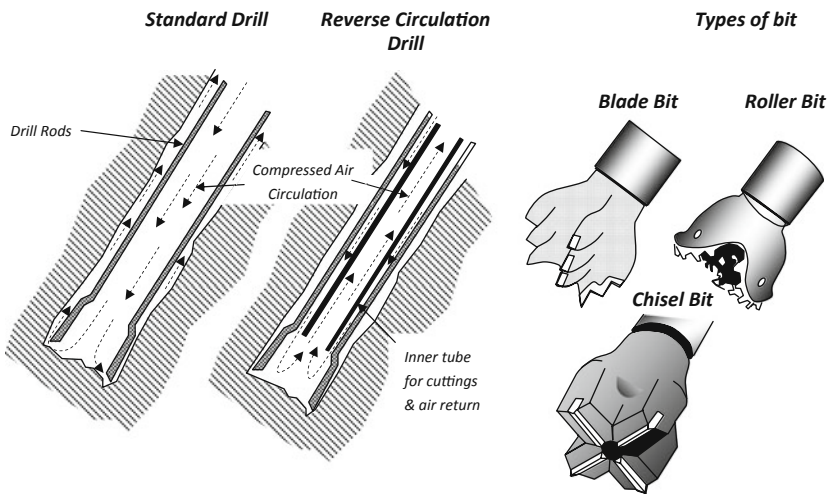
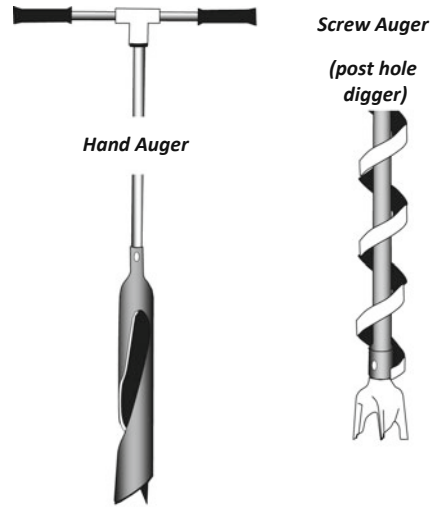

**Fig. 5.2** Cut-away sections through rotary percussion drills

## 5.2 Choosing the Right Technique

Selecting the right technique or combination of techniques is always a trade-off between speed, cost, required sample quality, sample volume; logistics and environmental considerations (see Table 5.1). Augering and RAB drilling provide relatively low levels of geological knowledge but are quick and cheap and so are useful principally as geochemical reconnaissance tools for collecting samples below areas of shallow overburden.

**Table 5.1** Comparison of exploration drilling methods

Drill type	Indications	Advantages	Disadvantages
Hand auger	Geochemical sampling in upper few meters of unconsolidated material	Hand portable and operable. Uncontaminated sample. Cheap	Poor penetration
Power auger (post-hole digger)	Geochemical sampling in upper few metres of unconsolidated material	Small lightweight machine – vehicle mounted or hand operated. Quick, cheap	Poor penetration (better than hand auger). Sample contamination
Rotary air blast (RAB)	Geochemical sampling to base of regolith Ideal regolith sampling tool	Large sample volume. No site preparation needed. Quick and relatively cheap. Some rock chip geological data	Poor penetration of hard rocks. Sample contamination. Limited depth. No structural data
Air core	Geochemical sampling where good characterisation of bedrock required	Small rock core return. Minimal contamination. Relatively quick and cheap. Can penetrate heavy clay/mud	Small sample size
Reverse circulation (RC)	Geochemical sampling hard and soft rocks to 200 m + Ore body proving above water table	Uncontaminated large volume sample. Rock chip geological data. Relatively quick and cheap cf. diamond	Large heavy rig may need access preparation. Limited structural data. Poor orientation control
Diamond	Ore targeting and proving to 1,000 m + High quality sample. Geological/structural understanding	Maximises geological information. Uncontaminated, undisturbed high-recovery sample. Accurate hole positioning/control	Some site preparation required. Water supply required. Relatively small sample size. Slow. Expensive

Large rotary percussion rigs can quickly drill a large-diameter hole (100–200 mm) with good sample volume and at reasonable cost. They are powerful machines capable of penetrating much deeper and through harder rock than the RAB rig. However, in normal rotary percussion drilling, the long sample return from drill bit to the surface along the outside of the rods may produce contamination from the walls of the hole. This problem can be especially acute when dealing with the low and often erratic concentrations typical of gold mineralization. The sample recovery system used in the RC drill rig (see Chap. 6) is designed to overcome the contamination problem and for this reason RC rigs are nowadays specified in most rotary percussion drilling programmes.

Diamond drilling provides the *premier* sample for both geology and geochemistry. A diamond impregnated cutting bit produces a solid cylinder of rock (Fig. 5.3).

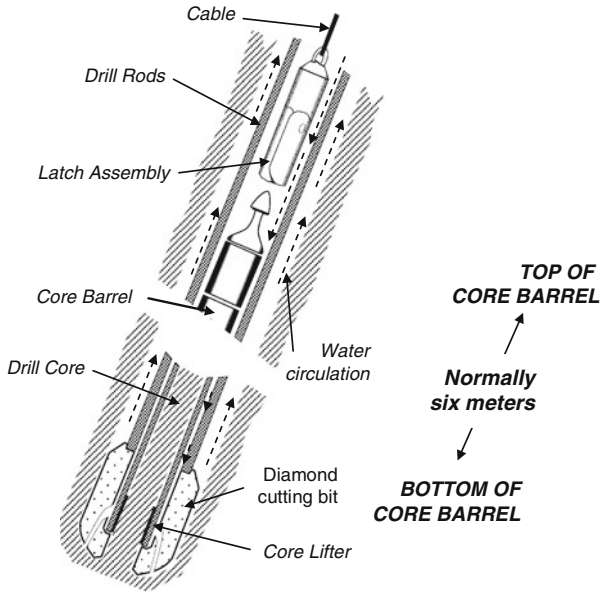

**Fig. 5.3** Cutaway section through a diamond drill bit, drill rods and core barrel

The rock sample can be obtained from any depth that is capable of being mined. Diamond drill core permits sophisticated geological and structural observations to be made, and can also yield a large-volume, uncontaminated sample with high recovery suitable for geochemical assay. Drill core can be oriented permitting structures to be measured (see Chap. 7 and Appendix B). Diamond drilling is also the most expensive technique. As a general rule, for the cost of 1 m of diamond drilling, up to 4 m of RC or 20 m of RAB can be drilled.

From almost all points of view, the larger the core diameter the better. Large-diameter holes provide better core recovery and deviate less. Lithology and structure are much easier to recognize in the larger core sizes and a larger volume sample is better for geochemical assay and ore reserve calculations. However, as the cost of diamond drilling is roughly in proportion to the core size, a compromise on hole size is usually necessary.

The specific requirements of an exploration programme play a large part in the choice of drilling technique. For example, if the area is geologically complex, or the exposure is poor, and there are no clearly defined targets (or perhaps too many targets), it may be imperative to increase the level of geological knowledge by diamond drilling. In this case, the geological knowledge gained from the diamond drill core can be used to help prioritize surface geochemical anomalies or develop conceptual targets. On the other hand, if discrete and clearly defined surface geochemical anomalies are to be tested to see if they are the expression of blind but shallow ore bodies, it may be sufficient to simply test them with a large number of RC or even RAB drill holes.

In arid terrains, such as the Yilgarn Province of Western Australia, the RC drill has been used in the discovery and development of a large number of gold ore bodies within the weathered rocks of the upper 80 m or so of the surface. It has proved to be an excellent compromise between cost, good sample quality for geochemistry, and some geological return in the form of small rock chips. In spite of this success, the RC rig is principally a geochemical sampling tool and it is dangerous to attempt to define an ore body on assay numbers alone. RC drilling data can seldom give an adequate geological understanding of mineralizing processes and in most cases will need to be supplemented with detailed mapping (where outcrop is available), by trenching and/or a selected smaller number of diamond drill holes.

The logistical requirements of the different drilling types also play a large part in selection of the best technique. RC rigs (and the larger RAB rigs) are generally very large, truck-mounted machines which have difficulty getting into some rugged areas without track preparation, and cannot operate on very steep slopes.<sup>2</sup> Diamond drill rigs are much more mobile; they are truck or skid mounted, have modest power requirements compared to an RC rig, and can be disassembled if necessary and flown to site by helicopter. Some rigs are even designed to be man-portable on dismantling.<sup>3</sup> Diamond rigs, however, require a large, nearby water source. The ability to be flown or carried into a site also makes the diamond rig suitable for operation in environmentally sensitive areas.

The air core machine is a compromise that has some of the features of RC, diamond and RAB drills. In ideal conditions the drill can produce small pieces of core and so provide better material on which to determine lithology and structure than normal RC cuttings. It is often capable of penetrating and producing a sample from sticky clays that might stop a conventional drill rig. As with all RC cuttings, recovery is usually good with minimal sample contamination. However, the sample volume is small compared to that from a large RC rig, and hence less suitable for gold geochemistry. Air core is usually intermediate in cost between normal RC and RAB drilling. Some available rigs are track mounted and are capable of getting into difficult-to-access sites.

### 5.3 Targeting Holes

Ore bodies are rare, elusive and hard to locate. If this were not so, they would hardly be worth finding. A single drill hole produces a very small sample of rock and the ore bodies we seek are already small relative to the barren rocks that surround them. Even after an initial discovery hole has been made into a potential ore body, if the subsequent holes are poorly positioned, the ore body may remain undiscovered, or, at best, an excessive number of holes will be needed before its true shape, attitude

---

<sup>2</sup>Although track-mounted RC rigs are available.

<sup>3</sup>The heaviest single component is the engine cylinder block. If less than 250 kg it can be carried on slings by four men.

and grade are defined. For the most efficient path to discovery, the explorationist has to make use of all available knowledge.

When geologists drill targeted holes they are testing a mental model of the size, shape and attitude of a hoped for ore body. The more accurate that model, the greater the chance that the hole will be successful. The model is the result of extensive detailed preparatory studies on the prospect, involving literature search, examination of known outcropping mineralisation, geological mapping at regional and detailed scales as well as geochemical and geophysical studies. These are the procedures that are described in the first four chapters of this book, and in Chap. 9. Compared to drilling, such preliminary studies are relatively cheap. Each drill hole into a prospect, whether it makes an intersection of mineralisation or not, (and perhaps especially if it does not), will increase geological knowledge and lead to modification or confirmation of the model and so affect the positioning of subsequent holes. The first few targeted holes into a prospect are always hard work, and it is in how she treats this stage of exploration that the explorationist most clearly reveals her true worth.

In order to most efficiently define the size and shape of a potential orebody, drill holes will normally be aimed at intersecting the boundaries of the mineralisation at an angle as close to  $90^\circ$  as possible. If the expected mineralization has a tabular, steep-dipping shape, the ideal drill holes to test it will be angle holes with an inclination opposed to the direction of dip of the body. If the direction of dip is not known (as is often the case when drilling in an area of poor outcrop, or testing a surface geophysical or geochemical anomaly), then at least two holes with opposed dips, intersecting below the anomalous body, will need to be planned in order to be sure of an intersection of the target. Flat-lying mineralization (such as a recent placer deposit, a supergene-enriched zone above primary mineralization, or perhaps a manto deposit) is normally best tested by vertical holes. These are not the only considerations. Holes are normally positioned to intersect mineralization at depths where good core or cuttings return can be expected. If the target is primary mineralization, the hole will be aimed to intersect below the anticipated level of the oxidized zone.

Ore bodies – such as stockwork or disseminated vein deposits – that are normally mined in bulk along with their immediate enclosing barren or low-grade host rock can present special problems for drill targeting. The boundaries of the mineralized zone determine the size of the zone and hence the tonnage of ore present; mineralized structures within the body, however, control the distribution of grade, and these structures may not be parallel to the overall boundaries of the zone. In the case of such deposits, the drilling direction that is ideal to assess overall grade may be very inefficient at defining tonnage. However, for initial exploration drilling, it is normally better for the first holes to be aimed at proving grade, rather than tonnage.

Once an intersection in a potential ore body has been achieved (a situation often described as having a “foot-in-ore”), step-out holes from the first intersection are then drilled to determine the extent of the mineralization. The most efficient drill sampling of a tabular, steep-dipping ore body is to position deep holes and shallow holes in a staggered pattern on alternate drill sections. However, the positions

selected for the first few post-discovery holes depend on confidence levels about the expected size and shape of the deposit and, of course, on the minimum target size sought. Since the potential horizontal extent of mineralization is usually better known than its potential depth extent, the first step-out hole will in most cases be positioned along strike (at a regular grid spacing in multiples of 40 or 50 m) from the discovery hole, and aimed to intersect the mineralization at a similar depth. Once a significant strike extent to the mineralization has been proven, deeper holes on the drill sections can be planned.

Epigenetic<sup>4</sup> vein or lode type deposits occur as the result of mineral deposition from fault fluids in localised dilation zones that result from fault movement (Cox et al., 2001; Sibson, 1996). High grade ore shoots therefore will tend to have the same shape and orientation as the dilation zone.<sup>5</sup> Dilation zones in faults are typically highly elongate and pencil shaped. An elongate ore body is known as an ore shoot. If the long axis of an ore shoot has a shallow pitch<sup>6</sup> on the fault plane, any hole targeted to drill below a surface indication or initial discovery hole is likely to pass below the shoot and so miss it. If the ore shoot pitches steeply, a hole collared along strike from an initial discovery hole may lie well beyond the shoot. Obviously, being able to predict the pitch of an ore shoot is important. How can we do this? The answer lies in understanding the nature of the fault structure which controls it.

The shape and orientation of dilation zones are controlled by the stresses that produced the fault. A detailed theoretical treatment of the stress/strain relationships of faults is beyond the scope of this book but can be found many standard texts (for example Ramsey and Huber, 1983) and published papers (for example Nelson, 2006). However, for the explorationist, the following brief description will be found useful in predicting the attitude of high grade epigenetic ore shoots.

E.M. Anderson (1905, 1951) pointed out that most faults forming in the upper few kilometres of the earth's crust are the result of principal stress directions that are oriented either parallel to, or normal to, the earth's surface. This has produced three common fault categories known as Andersonian faults. They are: normal faults, thrust (or reverse<sup>7</sup>) faults and strike-slip faults. Normal faults are the commonest type of fault to form in the upper few kilometres of the crust: they are steep dipping, but tend to flatten with depth. In normal faults, the direction of displacement – known as the movement or slip vector – lies in the direction of the fault dip such that fault movement produces a horizontal extension of the crust. Thrust faults are shallow dipping: the movement vector lies in the direction of dip so that fault movement

---

<sup>4</sup>Epigenetic deposits are those that formed after consolidation of their host rocks. Vein deposits are typical examples. This contrasts with syngenetic deposits, which formed at essentially the same time as their hosts. Examples of the latter are heavy mineral placer deposits or the (so called) sedimentary exhalative (SEDEX) deposits.

<sup>5</sup>Not all fault hosted ore deposits lie within dilation zones. In some cases their position is controlled by the physical or chemical nature of wall rocks, or by the intersection of two or more structures.

<sup>6</sup>For a definition of pitch see Fig. E.4.

<sup>7</sup>For the purpose of this discussion, a reverse fault can be thought of as a steep dipping thrust fault.

causes a horizontal compression or shortening of the crust. Strike-slip faults<sup>8</sup> are always vertical or steep dipping and the movement vector lies in the direction of the strike. Movement across the fault plane is defined as being either left-lateral (sinistral) or right-lateral (dextral). These fault categories are illustrated in Fig. 5.4. Dilation zones that form as a result of movement in all faults are highly elongate with their long axes parallel to the fault plane and oriented at a high angle to the movement vector for the fault.

How can we know what category of fault we are dealing with? To classify faults as normal, thrust or strike-slip, it is necessary to know (1) the attitude of the fault and (2) the movement vector across it. The movement vector can be determined from the displacement of marker beds across the fault (based on field mapping or drill hole interpretations) and from observing sense-of movement indicators that can be seen in outcrop or drill core. These are very important interpretation techniques but their full discussion is beyond the scale of this book. The reader is referred to the recommended further reading in Appendix F.

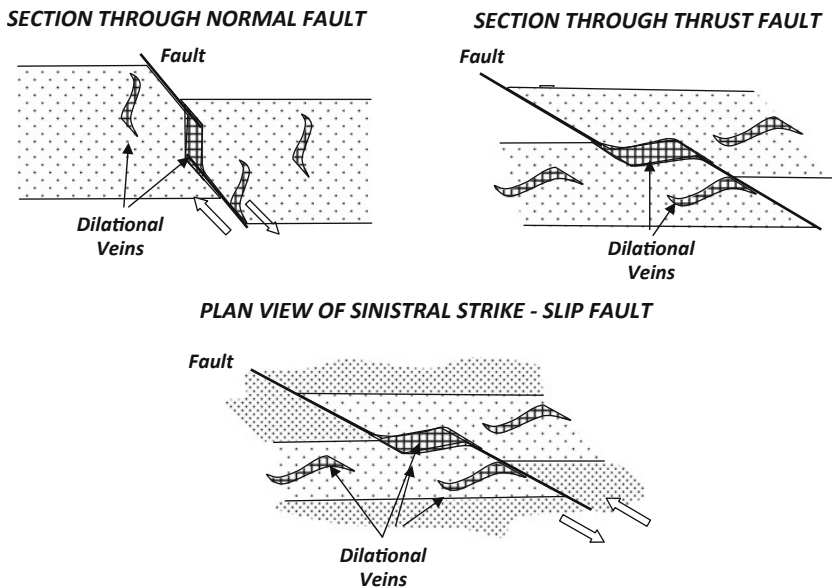

**Fig. 5.4** Sections illustrating the geometrical relationship of tensional openings (and hence potential sites for epigenetic ore deposits) with the principal classes of fault. In each illustration, the principal dimension of the dilational vein is at right angles to the page

<sup>8</sup>These are sometimes called tear, transcurrent or transform faults depending on their size and/or tectonic setting – but strike slip is a better term with no genetic implications.



Once we know, or suspect, the category of fault that epigenetic mineralisation is associated with, the following rules of thumb can now be used to predict the likely attitude of high grade ore shoots within or adjacent to it:

- In normal faults, the long axes of dilation zones (ore shoots) will tend to be sub-horizontal and to lie within portions of the fault that are steeper dipping than the rest of the fault, or within steep dipping spays off, or adjacent to, the main fault (Cox et al., 2001). Local bends in fault attitude are known as dilational jogs (McKinstry, 1948). For this type of fault an initial ore discovery should be followed up by drilling a hole to along strike from the discovery hole to intersect the target at the same depth.
- For thrust and reverse faults, the principal dimension of dilation zones will tend to be sub-horizontal and lie within those portions of the fault that are shallower dipping than the main fault plane, or within shallow dipping splays off, or adjacent to, the main fault (Cox et al., 2001; Sibson et al., 1988). For this type of fault, initial ore discovery should be followed up by drilling a hole to the same depth as the discovery hole and along strike from it.
- For strike-slip faults, dilation zones will tend to be steep-plunging. For a sinistral strike-slip movement, a dilation zone occurs in any left-stepping bend in the surface trace of the fault. For a dextral strike-slip movement, the dilation zone occurs in any right-stepping bend in the strike trace of the fault (Cox et al., 2001). In both cases, initial ore discovery should be followed up by a deeper hole on the same cross-section.

## 5.4 Drilling on Section

Once a zone of mineralisation (potential ore) has been discovered, and its shape and attitude approximately outlined, it needs to be defined in detail by a follow-up program of in fill drill holes. Each drill hole provides a one-dimensional (linear) sample through a prospect. The problem facing the explorationist is how to use this restricted data to create a three-dimensional model of the mineralisation and its enclosing rocks. Our brains are not really very good at conceptualising complex 3-dimensional shapes and relationships (although good mining and exploration geologists can do this better at this than most). The best way to solve the problem is to concentrate drill holes in a series of vertical cross sections.<sup>9</sup> Each section is thus a plane of relatively high data density and will facilitate interpretation. A series of parallel interpreted drill sections are two-dimensional slices through the prospect: they can be assembled (stacked) to produce a three dimensional model. Formerly,

---

<sup>9</sup>If holes are not grouped on sections but drilled with different azimuths and scattered irregularly across a prospect, combining the data points to build up a meaningful whole is much, much more difficult.

section interpretations were often plotted onto clear perspex sheets which were then physically assembled into a frame so that they could be viewed as a whole. Today, mining software allows digitised interpreted sections to be used as a basis for creating three-dimensional virtual reality shapes of ore bodies and rock masses which can then be rotated and viewed from all angles on a monitor. Although the software allows stunning presentation of results, the key interpretation stage is still the manual interpretation of two-dimensional drill sections.

Where drill holes deviate off section, assay and lithology data can be projected orthogonally (i.e. in a direction at right angles to the section) onto the drill section plane. Such projections are usually done by mining/exploration software programs. On these programs it is possible to specify the width of the “window” on either side of the section from which data will be projected. Obviously, if holes are not drilled at right angles to the strike of the feature, orthogonal projection will tend to distort true sectional relationships – a problem which will be exacerbated the further the data has to be projected (the wider the “window”) onto the section.

## References

- Anderson EM (1905) The dynamics of faulting. *Trans Edinburgh Geol Soc* 8(3):387  
Anderson EM (1951) The dynamics of faulting. Oliver Boyd, Edinburgh, 206p  
Cox SF, Knackstedt MA, Braun J (2001) Principals of structural control on permeability and fluid flow in hydrothermal systems. *Rev Econ Geol* 14:1–24  
McKinstry HE (1948) *Mining geology*. Prentice-Hall, New York, NY, 680p  
Nelson EP (2006) Drill hole design for dilational ore shoot targets in fault fill veins. *Econ Geol* 101:1079–1085  
Ramsey J, Huber M (1983) The techniques of modern structural geology. Volume 1: Strain analysis. Academic Press, London, 307p  
Sibson RH (1996) Structural permeability of fluid driven fault fracture meshes. *J Struct Geol* 18:1031–1042  
Sibson RH, Robert H, Poulsen KH (1988) High-angle reverse faults, fluid pressure cycling and mesothermal gold-quartz deposits. *Geology* 16:551–555

# Chapter 6

## Rotary Percussion and Auger Drilling

### 6.1 Rotary Percussion Drilling

In rotary percussion drilling, a variety of blade or roller bits (Fig. 5.2) mounted on the end of a rotating string of rods cut and break the rock. A percussion or hammer action in conjunction with a chisel bit can be used to penetrate hard material. High-pressure air pumped to the face of the bit down the centre of the rods serves to lubricate the cutting surfaces and to remove the broken rock (cuttings) by blowing it to the surface. The cuttings consist of broken, disoriented rock fragments ranging in size from silt (“rock flour”) to chips up to 3 cm diameter. In standard rotary percussion drilling, the broken rock reaches the surface along the narrow space between the drill rods and the side of the hole. In a mineral exploration programme all the cuttings emerging from the hole at surface are collected in a large container called a cyclone.

Small rotary percussion drills using standard recovery of broken rock to the surface are usually known as rotary air blast or RAB drills. Some models of very lightweight, power-driven percussion drills are available, which are capable of being hand held and can be ideal for operation in very remote or hard to access sites.

Reverse circulation (RC) drilling is a type of rotary percussion drilling in which broken rock from the cutting face passes to the surface inside separate tube within the drill stem (the system is properly called dual-tube reverse circulation).

#### 6.1.1 Reverse Circulation Drilling (RC)

With dual-tube RC drilling, compressed air passes down to the drill bit along the annular space between an inner tube and outer drill rods to return to surface carrying the rock cuttings up the centre of the inside rod. The cuttings enter the inner tube through a special opening located behind the bit called a crossover sub (not shown in Fig. 5.2). This is the reverse of the air path employed in normal “open hole” rotary percussion drilling (including RAB drilling), hence the name of the technique. The RC drilling procedure prevents the upcoming sample from being contaminated with material broken from the sides of the hole and so can potentially provide a sample

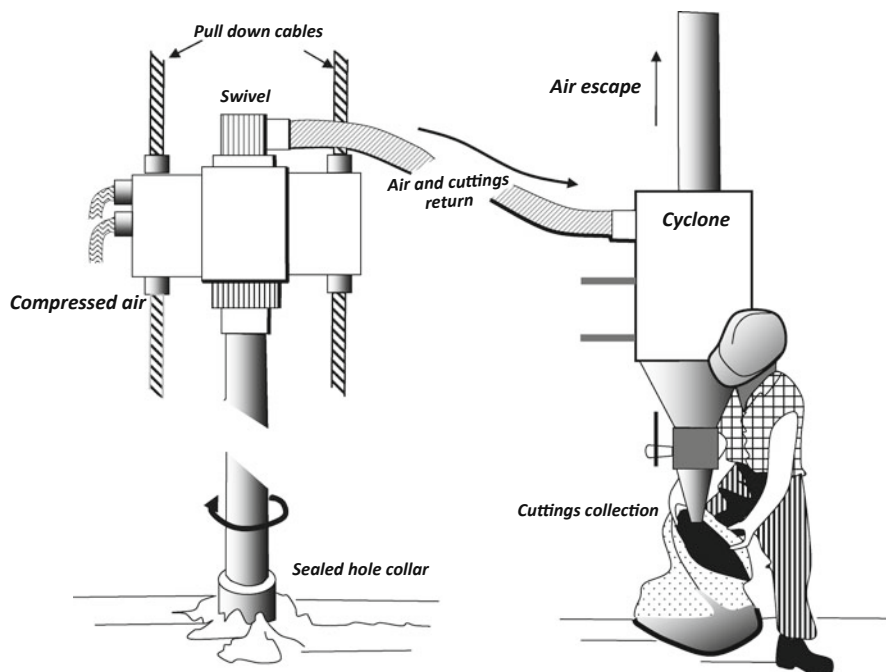

**Fig. 6.1** Collecting the rock cuttings from a reverse circulation (RC) drill

whose down hole position is exactly known. This is obviously of great value, especially in drilling gold prospects where even low levels of contamination can produce highly misleading results.

It is important that as much of the rock as possible for a given drilled interval is collected. The driller ensures this in three ways. Firstly, the hole is sealed at its collar so that the sample is forced to travel through the drill stem and into the collector at the top of the rods. Secondly, the driller continues to apply high air pressure for a period after each advance (usually 1 or 2 m) in order to clear all cuttings from the drill stem, before continuing the advance. The technique is known as “blowback”. Thirdly, at the drill head, all cuttings pass into a large-volume container called a cyclone, which is designed to settle most of the fine particles that would otherwise blow away with the escaping air (Fig. 6.1).

### 6.1.1.1 Geological Logging

Even though a multi-hole drill programme is planned in advance, each hole adds to geological understanding and this in its turn can lead to changes in the depth to which holes are drilled and in the positioning of subsequent holes of the programme. To effectively use an the RC rig, the geologist must be in a position to make on-site decisions on hole depth and hole position as drilling proceeds. This is only possible

if geological logging and interpretation is undertaken as the hole is being drilled. However, simply logging the hole is not generally enough; to fully understand the geological results; they should be hand-plotted on to a section and interpreted in a preliminary way in the field. RC drilling (unlike most RAB programmes) is relatively slow and usually gives the geologist plenty of time to log the hole and plot and interpret his results. To facilitate this process, a drill section should be drawn up in advance of drilling. The section will show the proposed hole as well as all other relevant geological, geochemical or geophysical information for that section, including the results from any pre-existing holes. The procedure is very much the same as that described in the next chapter for diamond drill core logging. Although, compared to diamond drilling, there is less time available for logging an RC hole, the detail of possible geological observations is also that much less.

Observation and interpretation are interactive processes – the one depends to some extent on the other. The features that are identified in logging drill chips are dependent upon the evolving geological model. Those geological features that prove able to be correlated between adjacent holes or between hole and surface will be preferentially sought for in the rock chips and recorded. It is only by specifically looking for particular features that are judged to be important, that the more subtle attributes and changes in the drill chips can be picked up.

The RC drill recovers broken rock ranging from silt size up to angular chips a few centimetres across. These allow a simple down-hole lithological profile to be determined. The normal procedure is for the geologist to wash a handful of cuttings taken from each drill advance (one or two meters), using a bucket of water and a sieve with a coarse mesh (around 2 mm) to separate the larger pieces.<sup>1</sup> The clean cuttings are then identified and the rock description for that interval entered on to a logging sheet. This sounds simple, but in practice, small rock chips can be very difficult to identify. In addition, the larger rock chips recovered in the sieve may be representative of only a portion of the interval drilled – usually the harder lithologies encountered in that interval.

Skill in rock identification with a hand lens is necessary. However, for adequate identification, small specimens of fine-grained rock require examination with a reflecting binocular microscope with a range of magnification up to at least 50×. A simple binocular microscope set up on the back tray of the field vehicle is an invaluable logging aid and its use is strongly recommended.

As logging consists of metre-by-metre description of the cuttings, any logging form drawn up into a series of rows and columns is adequate to record data. This is the analytical spread-sheet style of logging described in detail in Sect. 7.8.3. The rows represent the metre intervals; the columns are labelled for particular attributes that are considered important for that project. It is better to describe the observed features of the cuttings (mineralogy, grain size, colour, texture, etc.) than to simply record a one-word rock name. Such summary descriptors (i.e. metabasalt, porphyry,

---

<sup>1</sup>This should be done by the geologist, not by the field technician, since washing the sample is the best way to assess the percentage of fines in the drill cuttings.

greywacke, etc.) can be recorded in a separate column of the log sheet. Other attributes commonly recorded are percentage quartz or sulphide, degree and type of alteration, structures seen within the chips such as foliation, degree of oxidation, depth to water table and so on. A separate column should also be provided on the log sheet for verbal comments.

The detailed rock description refers only to the larger fragments recovered from the hole. Since these represent only the harder and more competent parts of the section drilled, it is important that a separate column record the estimated percentage of washed cuttings to fines. Thus 50% quartz vein fragments observed in the coarse washed portion of an interval where 50% of the total recovered cuttings consisted of fines, will probably equate to only 25% quartz vein material intersected in that interval.

The spread-sheet logging form can be readily created in a standard software program, such as Excel. The observations can then be entered directly, as they are made, into a battery-powered notebook or palmtop computer at the drill site.<sup>2</sup> The full range of possible observations in each descriptive category can be pre-printed along with a bar code on to standard laminated sheets. Data entry with a bar-code reader is then quick and simple. At the end of the day, or the end of the programme, the completed logs can then be downloaded from the field computer to a desk-top PC for storage, handling and plotting on section by one of the many exploration data software programs that are commercially available. It should be emphasized, however, that even where data are recorded electronically in this way, the geologist still needs to hand-plot the geology of the hole on to a section as drilling proceeds, as described above.

RC holes can deviate substantially from their starting azimuth and inclination. Holes that are targeted on ore, and are much more than 50 m deep, need to be surveyed as described in Sect. 7.9.

### 6.1.1.2 Display and Storage of Cuttings

The washed and sieved drill cuttings should be permanently stored in segmented, plastic cuttings boxes for later, more leisurely examination, should that prove necessary (Fig. 6.2).

In addition to this permanent storage, it is often a good idea to lay out samples of the washed cuttings from the entire hole on to a plastic sheet (a large sample bag is ideal) spread on the ground beside the collar of the drill hole (Fig. 6.3). The sequence of rocks through the entire hole can then be seen at a glance, and it is easy to spot progressive down hole changes. If the samples are left on display like this for the duration of the drilling programme, comparing intersections and establishing correlations between adjacent holes is made very much easier.

---

<sup>2</sup>Waterproof and dustproof protective covers are available for palm-top computers and make this system very practical.

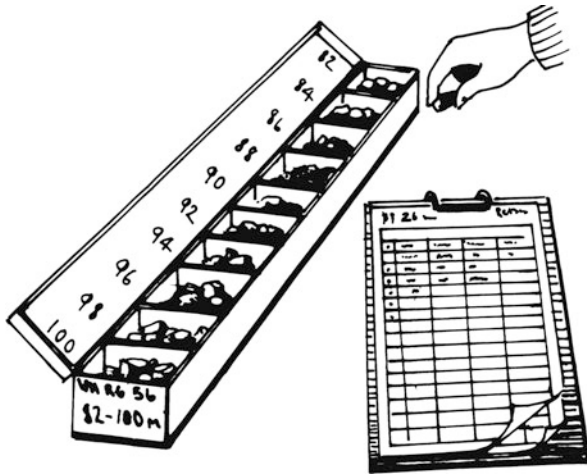

Fig. 6.2 Permanent storage of washed drill cuttings in a compartmented cuttings box

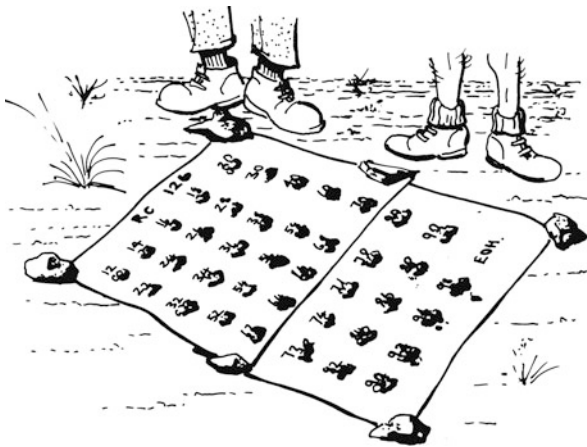
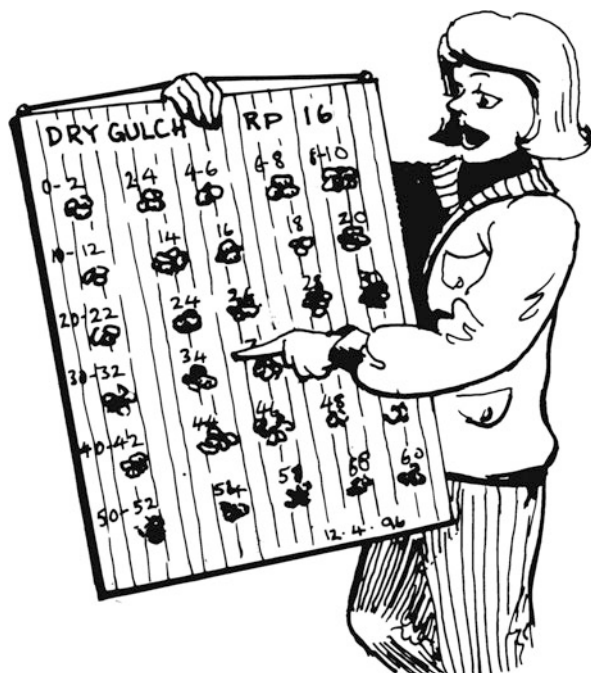

Fig. 6.3 Temporary field display of washed cuttings. Samples from each interval are laid out on a plastic sheet (sample bags) near the drill collar. This aids in identifying down-hole changes and permits quick and easy comparisons between adjacent holes in the course of a drilling program

With particular holes that are considered to be representative of a geological environment, the washed cuttings can be glued on to a suitably labelled cuttings board (Fig. 6.4). When displayed in this manner, it is easy to carry the board to site to act as a reference for future logging. A cuttings board is also invaluable for communicating the results of a drilling programme, and for helping to train geologists coming into an established project to ensure consistency of geological description.



**Fig. 6.4** A permanent display of washed cuttings. Cuttings from a typical hole or section are glued to suitably labelled board. The board can then be used as a reference for future logging, to maintain consistency of description between geologists, or for presentations

### 6.1.1.3 Sampling

The total amount of cuttings from each drilled interval is collected from the cyclone in a large polythene or polyweave bag (Fig. 6.1). Despite all precautions, it is usually impossible to avoid some sample loss – often fine dust or mud.

Conversely, in some cases, because the hole can locally “chamber out” below the ground, some intervals drilled will yield more sample volume than would otherwise be expected. Such variations affect the usefulness of the assay for that interval, and while this may not matter too much in reconnaissance drilling, it is obviously a serious problem in drilling out any mineralization. In detailed drilling, where sample loss (or gain) is suspected, the total material from each metre of advance should be routinely weighed and the weight recorded on the log form. Assays from intervals with significant sample loss or gain from the standard will obviously need to be treated with caution.

Cuttings from a one metre interval will normally weigh 25–30 kg. A representative split of the cuttings will therefore have to be made in the field to provide a sample for assay. Two methods of collecting this sample are commonly used (Barnes, 1987):



1. *Pipe sampling*: The bag of cuttings is thoroughly mixed by rolling and agitating the bag. Collecting a sample from the bag is done with a plastic pipe approximately 80 cm long, an internal diameter of around 6 cm and cut at an angle at one end. With the bag on its side, the pipe is inserted lengthways and rotated as it is pushed in (take care not to punch a hole in the bag!). Three pipe samples are collected parallel to the long axis of the bag, and two pipe samples diagonally across the bag. The five pipe samples are then combined to form the combined sample to be sent for assay. After collecting the combined sample, the pipe is thoroughly cleaned, both inside and outside, with a rag.
2. *Splitting*: Riffle splitters, such as that illustrated in Fig. 6.5, provide probably the most effective split of a sample but the procedure is more laborious and time consuming than the pipe sampling described above. Effectively cleaning a multi-stage riffle splitter between each sample can also be a tedious process, especially if the sample is damp. A compressed air line (if available from the drill rig)

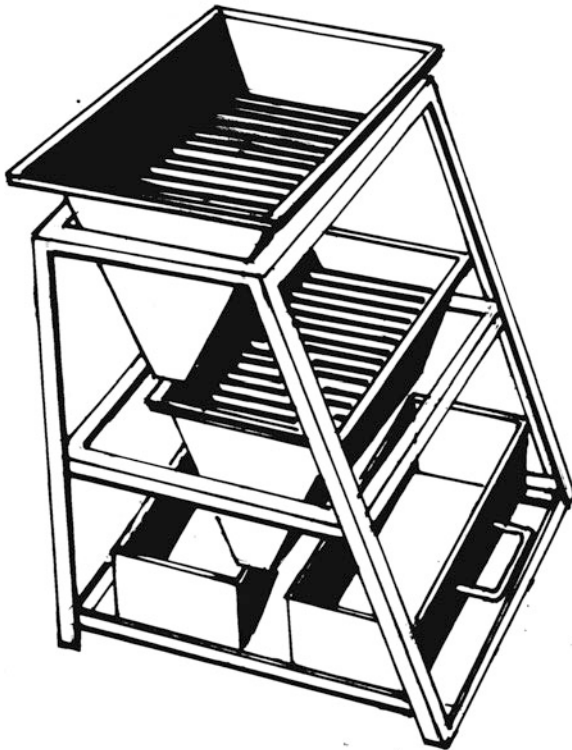

**Fig. 6.5** A two-stage riffle splitter. This model will split a large volume RC drill sample in the ratio 3:1. The small portion is sent for assay. The large portion is bagged and retained for possible future check assays

provides the most effective way of cleaning the splitter between samples. For accurate sampling within a mineralized zone, especially in gold prospects where nugget problems are suspected, the use of a riffle splitter is mandated.<sup>3</sup>

3. *Checking*: For effective quantification of error both in sampling and laboratory, the routine use of duplicate and standard samples is recommended. It is good practice to include at least one duplicate and one standard sample (i.e. one whose metal content is known within a certain specified range): such samples with various assay ranges for different elements can be purchased – in every batch of 20 samples sent to the laboratory.

#### 6.1.1.4 Sampling Below the Water Table

An RC rig can provide a useful sample from below the water table, provided the water flow is not too high. However, some contamination of the sample is inevitable, and for this reason RC drilling should not be considered in these conditions when detailed drilling is being undertaken to establish ore reserves.

For drilling below the water table, it is necessary to use a large rig with high air pressure, a sealed hole and a face-sampling bit.<sup>4</sup> The recovered sample will be wet and so generally cannot immediately be split for assay. It is recommended that the sample be collected in a large calico or polyweave bag (say 80 × 50 cm) that is left open. In 3 or 4 days of dry weather, most of the water will have evaporated through the weave and pipe sampling can then be carried out as described above. If large amounts of water are present, it may be necessary to collect the wet slurry sample into large plastic buckets (100 l garbage bins have been used) and allow it to settle. The settling of fine material can be speeded up by the addition of a flocculant. This procedure is undoubtedly tedious but, as the only other alternative to collecting a useable sample in these conditions is diamond drilling, it may be worth considering in some cases.

For assessment of mineralization below the water table, the appropriate technique is to use diamond drilling, particularly diamond tails on the end of the RC holes.

#### 6.1.1.5 Capping and Marking the Hole Collar

All drill holes must be sealed and permanently marked at the completion of the drill program. Sealing holes is particularly important for large diameter RC holes. It ensures that dirt and stones cannot fall down the hole (you might want to return with

---

<sup>3</sup>Some drilling companies provide a multi-stage splitter, attached directly to the cyclone, that produces a 1/8–7/8 split for assay sample and retained cuttings. These splitters are designed to be quickly and simply cleaned by a built-in vibrator and compressed air hose. This set up can offer quick convenient sampling, but needs to be checked constantly for the effectiveness of the cleaning process.

<sup>4</sup>With a face sampling bit the cuttings pass into the inner tube through a hole in the face of the drill bit. With normal bits (such as illustrated in Fig. 5.2) the cuttings pass into the inner tube through openings (called a cross-over sub) located immediately behind the drill bit.

a rig and re-enter one day) and animals cannot be injured. A prominent permanent marker also means that the hole collar can be easily relocated and identified, even after many years. RC hole collars should be sealed and marked in the same way as described for diamond drill collars (see Sect. 7.12 and Fig. 7.25).

### ***6.1.2 Air Core Drilling***

Air core is a specialized RC drill procedure where a small annular bit is used to cut a solid core of rock from relatively soft or easily broken material. The bit produces short sections of core which are recovered, along with broken rock chips, up the centre of the drill stem in the manner of a standard RC rig. The system is often capable of penetrating and coring soft sticky clays which might bind a normal blade bit.

### ***6.1.3 Rotary Air Blast (RAB) Drilling***

#### **6.1.3.1 Drilling Technique**

RAB drill rigs are light weight truck mounted rotary percussion machines that recover cuttings to surface through pumping compressed air down the centre of the drill stem. Cuttings pass to the surface up the outside of the rods and spill onto the surface where they are usually collected in a tray notched to fit around the drill stem, although a cyclone may be employed for collection in the same manner as an RC rig. The rigs are used as a geochemical sampling tool to quickly drill shallow holes (up to 60 m depth) in weathered rocks.

To obtain high-quality geochemical samples with as little environmental disturbance as possible, it is recommended that the following basic procedures be followed:

- The driller should ensure that the air pressure used is just sufficient to lift the cuttings from the hole and not blow them into the air.
- The air used can be moistened to reduce the dust levels.
- The driller should clear the cuttings from the drill stem between samples and on each rod change by means of blowback.
- All holes should be capped on completion. Plastic seals, which can be inserted into the hole to retain a plug of earth that is tamped down on top of them, are available commercially.<sup>5</sup>

---

<sup>5</sup>But you can make your own: a wedge-shaped concrete plug can be easily made using a plastic garden flower pot as a mould. A short length of garden hose or black poly pipe inserted into the wet concrete provides a convenient handle for the solidified plug. Making a supply of such plugs is a useful occupation for technical assistants during the inevitable “flat” spots of exploration programmes – such as a rig break down or the arrival of the wet season.

### 6.1.3.2 Geological Logging

A limited amount of geological information can be obtained from RAB cuttings and they should be routinely logged. Because of the speed with which drilling can sometimes take place (over 1,000 m a day is not uncommon when drilling shallow, close-spaced holes), detailed logging is often not possible. However, it is important to record the weathering profile down each hole so as to understand the significance of the geochemical results, and a bedrock lithology identification helps build up a subsurface geological map. A description of the vertical profile through the regolith section and a bottom-of-hole bedrock lithology descriptor should therefore, as a minimum, be made routinely for each hole.

As with other types of drilling, the geologist should attempt to keep up with the drill rig in his or her logging, and although there may not always be enough time to plot results on to a map or section as drilling proceeds, it is still important to be aware of the geology being defined by the drilling as it proceeds. In some cases this may lead to a decision to modify the planned programme or to ideas being generated which will lead to particular features being sought in the cuttings.

Recording the observations is similar to RC drill logging. The log sheet is drawn up in to rows representing the metre advances, and columns for each attribute that it is desired to record. When describing vertical profiles through the regolith, the colour, grain size and texture of the cuttings are important descriptors. Make use of Munsell® soil colour charts<sup>6</sup> for scientifically defined colour words, and avoid such subjective terms as “chocolate brown”, “brick red”, “khaki” etc. (chocolates, bricks and khakis, after all, come in many shades).

Many of the attributes of the cuttings can be recorded by a system of abbreviations, or by code numbers and letters. The identification of the rock chip – if one can be made – should be kept for a separate entry on the log.

The rows and columns of the log sheet represent a spread-sheet and can be created on standard spread-sheet software. The logging can then be done directly into a suitably protected notebook or palm-top computer at the drill site. Data can be entered by key-stroke or by using a bar-code reader (Sect. 6.1.1). When convenient, the data can then be downloaded to a larger PC for storage, processing or plotting with one of the many exploration data software packages that are available.

The bottom-of-hole washed sample should be stored in plastic cuttings boxes (Fig. 6.2). As described in the section on RC drilling, display of representative cuttings from the hole either on plastic sheets laid on the ground beside the hole (Fig. 6.3), or by gluing to a cuttings board (Fig. 6.4), can greatly facilitate establishing correlations between holes. More detailed logging of the cuttings can subsequently be made from the stored sample if necessary.

---

<sup>6</sup>Munsell® soil and rock charts are a commercial system for objective, repeatable scientific colour description in terms of three attributes – value (lightness/darkness), hue (colour) and chroma (strength). The charts allow matching the sample to a series of printed colours that cover the range of normal soils and rocks.

### 6.1.3.3 Sampling

In the past, a common method of sampling was to grab sample the cuttings from the hole where it intersected bedrock. The danger of this procedure was that the bottom-of-hole sample could have come from a zone of metal depletion. However, sampling every drilled interval can often be prohibitively expensive. For reconnaissance drilling of gold prospects in weathered terrain, it is therefore recommended that the entire drill hole be sampled by means of composite sampling. Composite sampling takes advantage of the ability of modern assay methods to detect very low levels of gold, and the enhanced concentrations of gold and related indicator elements that can occur in different parts of the weathering profile.

Composite sampling can be accomplished by means of either grab sampling or pipe sampling.

With grab sampling, cuttings for each advance of the drill (usually 2 m) are placed on the ground and a sample is taken by running a trowel lengthways through the spoil heap. Samples from several spoil heaps constitute the composite sample. The main advantages of this method are that it is quick and relatively cheap and the cuttings can be laid directly on to the ground without bagging. The main disadvantage is that the heaps rapidly coalesce and disperse, especially if subjected to rain, and it can sometimes be difficult or impossible to subsequently carry out a more detailed sampling of the hole. It is also easy when sampling in this manner to contaminate the sample with surface material, and, of course, the reverse can also be true. For environmental reasons it is usually important to ensure that the surface material is not contaminated by the sample.

An alternative method is to bag all the cuttings for an advance of the drill, and to sample the bag using pipe sampling in the manner more fully described under RC drilling (Sect. 6.1.1). In composite sampling of RAB cuttings, one pipe sample is taken diagonally through each bag of spoil. This determines the largest practical size of composite sample – a composited sample from five spoil bags (each representing a 2 m advance) will weigh around 4–5 kg. For this type of composite sampling, it is only necessary to clean the pipe between each composite interval. Pipe sampling is extremely rapid and one experienced field technician can easily keep up with the RAB drill.

Since composite sampling is aimed at detecting low element concentrations in weathered rocks, low detection levels must be specified for assaying the composite sample (in the case of gold, at ppb – part per billion – level). Any anomalies detected by composite sampling, no matter how low, should be immediately checked by separately resampling each 2 m interval from the plastic bags of stored cuttings or from the spoil heaps on the ground.

When using a RAB drill to test known mineralisation or a well-defined anomaly, each 2 m advance of the drill through the mineralized zone would normally be bagged and separately sampled and assayed.

For effective quantification of error both in sampling and laboratory, the use of duplicates and standards should be routinely used. It is good practice to include at least one duplicate and one standard sample in every batch of 20 samples sent to the laboratory.

## 6.2 Auger Drilling

In this drilling system, rock is cut and broken with a simple blade bit mounted on the end of a rotating string of rods. As the drill advances, extra rod sections are added to the top of the drill string. The broken rock can be collected in two ways. In the bucket auger, the rock is collected in a small barrel behind the bit which, when full, is simply pulled from the ground to be emptied. The hand auger is an example of a small bucket auger. In the other system, called a screw auger, the broken rock is passed to the surface by a spiral screw thread along the rod string (see Fig. 5.1).

Power augers are usually a simple petrol-engine driven screw auger, with a blade bit at the end, mounted on the back of a small trailer or truck. The Archimedean screw along the rods lifts the sample to surface. Some small power augers can also be hand held. Machines used in exploration range from simple post-hole diggers to drills designed specifically for mineral exploration. They are capable of drilling a few metres to a few tens of metres into weathered or poorly consolidated material.

Rock and soil cuttings obtained from the screw auger as drilling proceeds spill on to the surface, or into a circular sample collection box that is slotted to allow it to be placed around the drill collar. The cuttings may be contaminated with material from the walls of the hole, and it is difficult to know from what exact depth any particular observed geological feature or geochemical sample is derived. Allowing the machine to run for a few minutes to clear the rods before resuming the advance will produce a cleaner sample but some contamination is still possible. When the rods are pulled, a bottom sample from around the bit and lowermost auger flight can be collected. These base-of-hole cuttings are usually reasonably uncontaminated and can provide an adequate geochemical sample.

Augers are a useful tool for quickly and cheaply collecting geochemical samples from below shallow overburden, or where some surface contamination might be suspected (e.g. down-wind from old mine tailings). They are not capable of penetrating hard or consolidated rock. Hand augers have proved useful in remote areas to pinpoint the source of stream-sediment geochemical anomalies. They are invaluable for collecting ridge and spur geochemical samples in rugged or remote terrain.

Hand augers offer the ultimate in portability and permit taking a sample from the top few metres of unconsolidated surface material. The sample in hand augers is collected from the barrel on the lower flight that is pulled directly out of the ground (Fig. 5.1); it is therefore uncontaminated and is a potentially effective geochemical sample. Hand augers work only in soft, poorly consolidated materials and will be stopped immediately by any rock fragments or heavy clay.

Hand augers are used extensively as a geochemical tool for collecting C-horizon soil samples from below shallow overburden, particularly in rugged, inaccessible or rain-forest terrain. Even if the C-horizon is too deep to be accessed by hand auger, the tool permits, at the very least, taking a sample of weathered bedrock from below the surface layer of humus and leaf-litter. Hand augers are also widely used as a reconnaissance tool in heavy-mineral sand exploration.

## Reference

Barnes JFH (1987) Practical methods of drill hole sampling. Bulletin/Australian Institute of Geoscientists 7: Meaningful sampling in gold exploration. Papers presented at Seminar No. 5, Perth, Sydney, 26 Oct 1987.

# Chapter 7

## Diamond Drilling

### 7.1 Preamble

In diamond drilling, an annular, diamond impregnated cutting tool (called a bit) mounted on the end of a rotating string of hollow steel rods, cuts a solid cylinder of rock (core) which passes up inside the drill rods as the bit advances (Fig. 5.3). The bit is lubricated with water (or sometimes a special water/mud mixture) which is pumped to the cutting face down the inside of the rods, before returning to the surface between the rods and the sides of the hole. At surface, the return water is usually collected in a sump where fine suspended ground rock material can settle. The water can then be recirculated to the drill bit.

Standard core sizes range from 27 to 85 mm diameter.<sup>1</sup> The core enters an inner tube (the core barrel) located inside the outer drill rods immediately behind the bit. The cut rock is prevented from falling back into the hole by a wedge-shaped sleeve (called a core-lifter) mounted at the base of the barrel. Core barrels normally hold up to 6 m of core, depending on the size of the drill rig. When the barrel is full, the drilling is halted and a special device called an overshot is lowered down the inside of the rods on the end of a steel cable (the wire line). The overshot locks on to the top of the core barrel. A pull on the cable then causes the core-lifter to tighten and grip the base of the drilled core in the barrel, thus breaking it free. The barrel containing the core can then be drawn to surface up the inside of the rod string.<sup>2</sup> Once on the surface, the core is removed from the barrel and laid out in core trays. A split tube barrel is available which splits into two pieces lengthways, so facilitating core removal – this is particularly useful when the core in the barrel is soft or highly fractured. Once emptied, the barrel is dropped down the hole to automatically lock into its position just behind the bit, and the drill advance is resumed.

---

<sup>1</sup>The commonly used standard core diameters for wireline drilling are AQ, 27 mm; BQ 36.5 mm; NQ 47.6 mm; HQ, 63.5 mm and PQ, 85 mm.

<sup>2</sup>The system described here is called wire-line drilling and was invented by the US Longyear Company in 1958. By the late 1960s it was in almost universal use. Before wireline drilling, the whole string of rods had to be pulled from the ground in order to recover core from each advance of the drill.



As described in Chap. 1, diamond drilling of a prospect typically goes through two phases. The required geological inputs for the two phases are different. The first phase comprises initial exploration drilling – the target generation and target drilling exploration stages (Sects. 1.5.1 and 1.5.2). In these stages drilling is aimed primarily at a geological understanding of the prospect and a qualitative assessment of the potential for ore. This is the most critical stage of prospect drilling. The geological logging process is often difficult – unfamiliar rocks are being encountered and it is hard to know which of the almost infinite number of observable core features are significant, can be correlated between holes and are critical to understanding the mineralization. Yet if the mineralization is not understood an ore body might be missed. The geological returns gained from the first few drill holes into any prospect therefore need to be maximized, and observation and recording should be as detailed as can be achieved. As a general guide, a geologist should not expect to average more than 5 m of core logging per hour when logging mineralized rock, and she should be prepared to pick up and examine every surface of every piece of core.

The second phase of drilling is undertaken after it is determined that there is a good probability that an ore body is present. This is resource evaluation and definition drilling and is largely aimed at establishing economic (such as grade and tonnes) and engineering parameters. If a project gets as far as this stage (and the majority will not), the main geological questions should have been answered and the geologist will have passed the steep part of the learning curve. With resource evaluation drilling, there is normally an increase in the meterage of core being produced and the logging requirement is now for the speedy and accurate collection and recording of large volumes of standardized data.

## 7.2 Some Definitions

The *azimuth* of a non vertical hole (usually referred to as an angle hole) is the horizontal direction in which it is drilled and is usually expressed as a compass bearing (Fig. 7.1).

The *inclination* of a hole is the angle that it makes with the horizontal and is measured in the vertical plane. Inclination is a negative number if the hole is drilled below the horizontal, and a positive number if above. Since holes collared at surface are almost invariably angled downwards, the negative sign is usually omitted.<sup>3</sup> However, the inclusion of a plus or minus prefix is important when dealing with holes collared underground, since such holes are as likely to be angled up as down.

The *drill section* is the vertical plane in which a hole is drilled. Although all holes are set up to drill in the vertical plane they may deviate out of this plane in the course of drilling.

---

<sup>3</sup>Although it may be necessary to include the sign when inputting hole survey data to some computer programs.

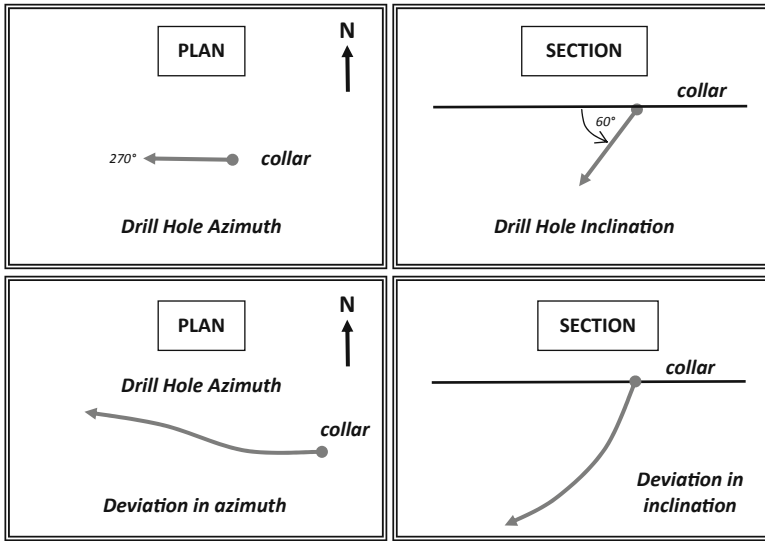

Fig. 7.1 Definition of terms describing the orientation of drill holes

*Deviation* is the amount by which a hole swings away from its initial azimuth and inclination during the course of drilling (Sect. 7.9.1). Drillers use many techniques to control the amount and direction of deviation of a hole. Details of this specialised process – known as hole deflection – can be found in standard drilling manuals such as Cumming and Wicklund (1985), Hartley (1994) or The Australian Drilling Industry manual (1997).

The *Core Axis (CA)*, sometimes called the *Long Core Axis (LCA)*, is the imaginary line running along the centre of the cylindrical drill core.

An *Oriented Hole* is one in which a *Down Hole Survey* has been conducted to determine the exact azimuth and inclination of the core axis at a number of points down the hole. This survey determines the amount that the hole has deviated from its starting azimuth and inclination and would normally be carried out on all holes that are more than 50 m deep. For more information on deviation and down hole surveys see Sect. 7.9.1.

Core recovered from a hole is only partially oriented by the down hole survey. While the attitude of the core axis is determined, core removed from the hole will have rotated by some unknown amount about the core axis. To fully orient a piece of core, it is therefore also necessary to know the original attitude of a point on the recovered core. To do this, a point with a known orientation relative to the core axis has to be recorded by some means before the core is broken free from the ground and drawn to the surface. This type of survey is known as a *Core Orientation Survey* and, if successful, provides *Oriented Core*. The way such surveys are carried out, the special procedures for handling oriented core and how to measure structures in oriented core are set out in detail in Appendix B.

### 7.3 Before You Begin

A number of steps should be carried out before commencing any first-phase drilling of a prospect, these are:

- Map the surface outcrop around the drill hole in as detailed a scale as possible (preferably 1:1,000 or better) before drilling commences. Ideally, the scale of core logging and surface mapping should be comparable, but the lower density of geological information available on surface means that the surface map is usually compiled at a smaller scale.
- Draw a geological section along the line of the proposed hole. If there is any significant surface relief then the section should show this with a vertical accuracy of at least a metre.<sup>4</sup> If existing topographic data are not sufficiently accurate to draw the profile, then a special topographic survey of the section line should be undertaken.
- Plot on to the section the trace of the proposed hole (and data from any existing holes on the section) and all known surface geology along with geochemistry and geophysics data. If necessary, project the data along strike so that it lies on the section.
- From the section, make predictions on the expected down-hole intersections of important geological elements.
- These predictions should be written down, along with a brief drill hole justification statement. This practice forces the project geologist to think about the important questions: “Why am I drilling this hole?” and “What do I expect to find?” Apart from this, a hole justification statement such as this keeps the geologist honest when the actual hole results become known.

### 7.4 Setting Up a Diamond Hole

It is usually essential that a drill rig be set up on a specific location and with precise azimuth and inclination. The following procedure is recommended to ensure that this is done correctly:

- Mark the approximate position of the hole collar with a peg or some flagging.
- Clear the site by bulldozer (if necessary) and dig the water-return sump. A square flat area measuring a minimum 15–20 m of side will need to be cleared.
- The original peg has by now generally been destroyed. Reposition and mark the hole collar with a new peg. The exact collar positioning to within a metre or so is

---

<sup>4</sup>The position in three dimensions of surface features should be determined to a comparable accuracy to the location of features in the drill core. Even where there is no surface outcrop, the surface profile of the section often reflects the influence of underlying geology and can provide valuable extra clues when it comes to interpreting the drill section.

seldom vital. The important thing is that the actual coordinates of the collar can be determined by survey to any given degree of accuracy required after the hole has been drilled.

- Mark the peg with the hole number and the programmed bearing and inclination.
- Establish the azimuth of the proposed hole by placing fore-sight and back-sight pegs 20–50 m on either side of the collar. The drillers will use these sighters to position their rig. Make sure they know which is the fore-sight and which the back-sight!
- After the rig is set up, but before any drilling takes place, check both azimuth and inclination with compass and clinometer.

## 7.5 Geological Observation

Core should ideally be observed in direct, bright natural light. If full sunlight is too hot, logging under a light shadecloth screen can be acceptable. If weather is too cold or wet to log the core outdoors, a space indoors before large sun-facing windows should, if at all possible, be made available. Failing this, strong, overhead artificial lighting must be provided. Core trays to be logged should be arranged at a comfortable height on racks. The core should then be cleaned of any grease or mud left from the drilling process. Sometimes features in core can be more easily seen when it is wet, sometimes the core is better observed when dry. Wetting core is most easily achieved by using a hose fitted with an on/off spray nozzle. If no piped water supply is available, a spray bottle of water or a bucket and brush will serve the same purpose. Constantly switching from handling wet and dirty core to entering data on paper log sheets or computer keyboard means you will have to keep a good supply of cotton rags on hand.

Having arranged a comfortable physical environment in which to examine diamond drill core, one of the first problems often found is that the detail of observation possible is so great that major features and contacts of the rock are difficult to spot. In other words, it can be hard to distinguish the wood from the trees. To overcome this, it is a good idea to initially make a complete summary log of the entire hole as the core is being drilled. This first-pass scan of the core will establish the immediate and paramount question of whether there is any mineralization present, and if there is, provide the control for an immediate start on the process of sampling for assay.<sup>5</sup> At the same time, the summary log should define the major boundaries and structures present, and provide the context within which the more detailed log can subsequently be prepared.

Most geologists will find it easier to log the detail of lithology, structure, mineralization, alteration and so on in separate passes over the core rather than trying to

---

<sup>5</sup>As W.C. Peters (1987) says in his book *Exploration and Mining Geology*: “Logging is . . . most quickly done for the main objective of the moment. The main objective of the moment is to find or to outline an orebody, not to log core.”

observe and record these different features simultaneously. The job of the geologist can be made very much easier if routine procedures, such as measuring core recovery, marking core in 1 m intervals and transferring orientation marks, are carried out by an experienced field technician (see Sect. 7.12).

Important decisions such as deepening or terminating a hole, or siting the next hole, may have to be made whilst drilling is progressing. Core should therefore be logged in as much detail as possible, hand-plotted on to section, and its significance assessed on a daily basis as drilling progresses. More detailed logging can subsequently be made when more time is available. Indeed, in many if not most cases, as new ideas evolve, or between-hole correlations are sought, the core will have to be logged and re-logged many times. There are undoubtedly many ore bodies stacked away in core farms still waiting to be discovered.<sup>6</sup>

## **7.6 Recognizing and Interpreting Structures in Core**

### ***7.6.1 Statement of the Problem***

Large scale structure can be observed in a first pass scan along the core tray, but in order to see the subtler small structures, core has to be removed from the core tray and rotated and tilted in the light. Having identified a structure, the core should then be approximately oriented in the hand so that a qualitative idea of the orientation of the structure can be gained.

Geologists are familiar with the appearance of rock structure where it is exposed on the flat, or relatively flat, surface such as that provided by an outcrop, a map, a section or an illustration in a structural geology text book. However, the same structure can often be difficult to recognise or correctly interpret where it is exposed on the cylindrical surface of a piece of drill core. Another problem inherent to drill core is that of scale. It can be difficult to see large structures, even of the order of a few metres across, when dealing with a piece of core that is only a few centimetres across. The next few sections will examine how common structures appear in core, and how they are interpreted.

### ***7.6.2 Planar Structures***

The trace of a planar structure (such as a bedding plane, cleavage, joint or mineral vein) on the surface of cylindrical drill core outlines an ellipse. This referred to as the intersection ellipse. Any ellipse can be defined by a long axis and a short axis at right angles to each other. The ends of the long axis of the intersection ellipse

---

<sup>6</sup>Roy Woodall, former Exploration Director for Western Mining Corporation, was quoted (1995) as saying: "We've relogged the drill core from the Kambalda area (West Australian Ni/Au Camp) three times and each time we do it, we find a new orebody."

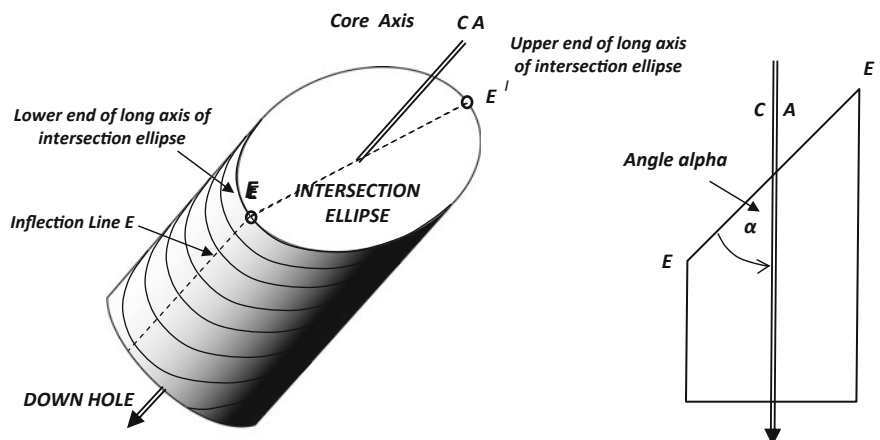

**Fig. 7.2** Geometry of the intersection of planar surfaces with drill core

are marked on the surface of the core by inflection points (i.e. points of maximum curvature) on the trace of the plane. If a set of close-spaced parallel surfaces, such as regular fine bedding or a penetrative cleavage, are being intersected, the inflection points for each individual surface can be joined to form a line running along the core length. This line is known as the inflection line for that set of surfaces. The acute angle between the ellipse long axis and the core axis is known as angle alpha ( $\alpha$ ) (Fig. 7.2). The more oblique the intersection of the plane with the core (i.e. low alpha angles), the more elongate the intersection ellipse, and the better the definition of the inflection points which define its long axis on the core surface. There are two limiting cases. In the first, where the core intersects the surface at right angles ( $\alpha = 90^\circ$ ), the intersection of the plane with the core is a circle and no unique axis can be defined. In the second case, where the core has been drilled parallel to the surface ( $\alpha = 0^\circ$ ) the intersection trends along the length of the core; in theory for ever: but in practice only for as long as this particular geometry holds good. In this latter case, the ellipse long axis is of infinite length, and there are no inflection points on the core surface. These three cases are illustrated in Fig. 7.3.

### 7.6.3 Faults

Minor faults (micro faults) are often well exposed in core. Where the fault intersects an earlier structure at a high angle, the displacement across the fault can be easily observed (Fig. 7.4, left). It is often tempting to ignore such minor faults during logging on the grounds that the structure and amount of displacement are insignificant. However, the displacement of minor faults frequently mirrors that of adjacent, associated major faults. Since it is seldom possible to directly determine the

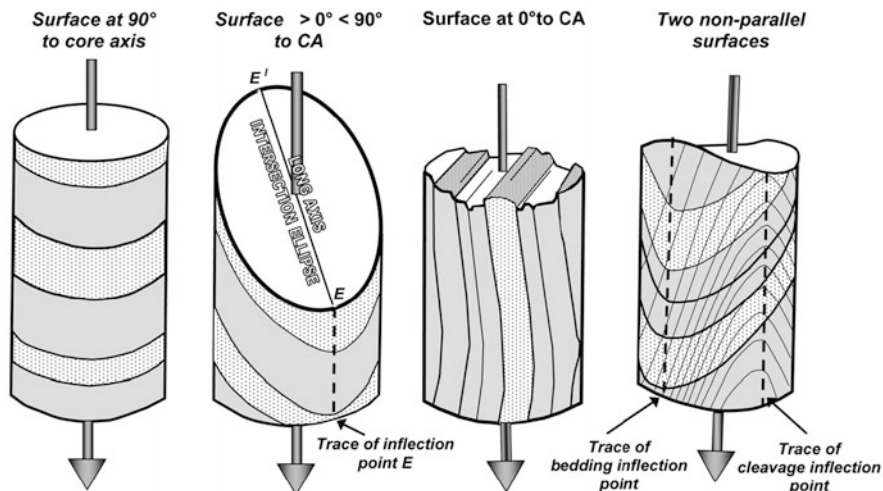

Fig. 7.3 How planar surfaces look in drill core

displacement vectors of major faults in drill core, all data on associated structures can have great relevance, and should be recorded.

Large brittle faults (Fig. 7.4, centre) are normally cored as zones of broken core and clay, often with significant core loss. Their nature as major fault zones is often not recognised unless associated with significant mineral veining. Large brittle fault zones usually carry significant water, and may show the effects of supergene

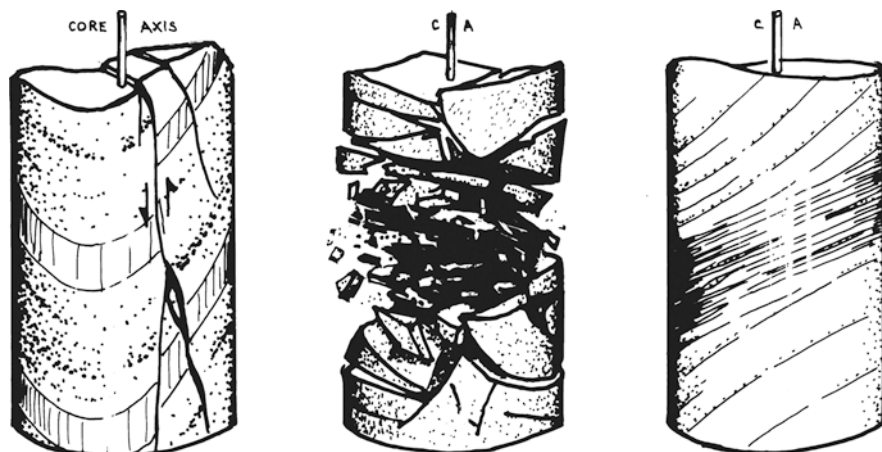

Fig. 7.4 How faults look in drill core. On the *left* is a small brittle fault. Large brittle faults (*centre*) produce broken disoriented core and their attitude cannot generally be measured. On the *right* is a small ductile fault. These are usually coherent structures that provide information on their attitude and, if you are lucky and the core is oriented, the sense of displacement across them

alteration to anomalous depths. It is generally not possible to directly measure the attitude of large brittle faults in core, but the displacements across them can often be deduced by observing the displacement across minor associated structures (see above). Another way of deducing fault displacement is by correlating the fault trace between adjacent holes and looking for displacement of interpreted rock sequences across the fault line.

Small ductile faults in core are generally rather obvious as tabular zones of intense alteration and high strain (Fig. 7.4, right). Ductile fault zones often possess internal structure which can be used to determine the sense of movement across them.<sup>7</sup> However, ductile fault zones can be very wide structures – sometimes many kilometres across – and the margins of the zone are typically gradational. Identifying the true nature of such a deformation zone on the basis of one drill hole (let alone a small piece of core from such a hole) can be difficult. The internal structures within small ductile faults provide one of the most generally useful means of determining the direction of fault movement. In the example of Fig. 7.4, the sense of asymmetry of the foliation indicates an upper block to the right movement on the fault. However, this only has absolute meaning if the core is correctly oriented. See Hanmer and Passchier (1991) for a detailed review of sense of movement indicators.

#### 7.6.4 Linear Structures

Linear features can have very different appearance in core dependant upon the rock structures that define them. There are four possibilities (Cloos, 1946):

1. A lineation may be defined by the line of intersection of two surfaces such as bedding and cleavage (Fig. 7.5b). If the core has broken along one of the surfaces, the trace of the other surface may be present as a lineation on the exposed surface. However, in the general case, intersection lineations cannot be directly observed in core, and can only be deduced by observing the surface trace of the two surfaces that define it. The orientation of the line of intersection could then be determined by separately measuring the orientation of the two surfaces, plotting them as great circles onto a stereonet, and reading off the orientation (the trend and plunge) of the point where the two great circles intersect.
2. The long axes of elongate ellipsoidal bodies in a rock that has undergone a stretching deformation (Fig. 7.5a). Such marker structures may include deformed clasts, isolated boudins or metamorphic mineral aggregates. They define a non-penetrative lineation. Although the linear bodies have a constant orientation, they appear on the core surface in a variety of cross sections, depending upon the variable angles of intersection that their long axes make with the cylindrical core surface. High angle intersections have circular, or relatively squat ellipsoidal shapes; low angle intersections will display more elongate shapes.

---

<sup>7</sup>But only if the core is oriented.



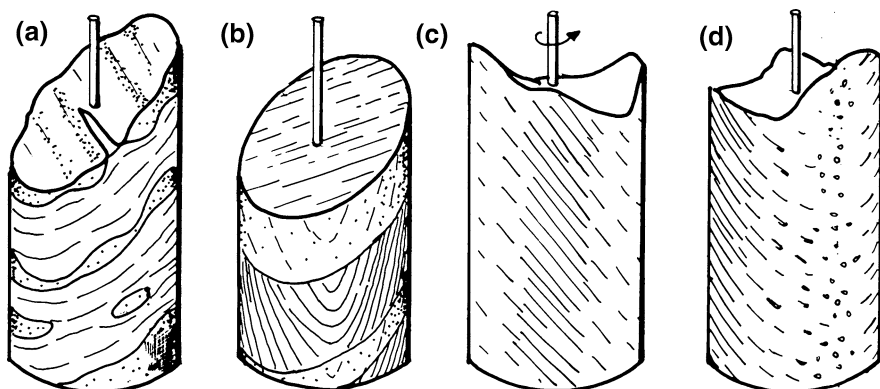

**Fig. 7.5** How lineations look in drill core. At (a), tectonic flattening and stretching has produced *rodded shapes* (mullions) in a once-planar bed. At (b), lineation is defined by the intersection of bedding and cleavage and is exposed where the core has broken across a bedding surface. (c) and (d) illustrate a fine penetrative metamorphic mineral lineation. Note the different appearance of the lineation as the core is rotated about its long axis

3. A parallel alignment of elongate minerals throughout the body of a rock produces a penetrative mineral lineation (Fig. 7.5c, d). This lineation will show continuously variable patterns of intersection around the cylindrical core, dependent upon the changing angle between the core surface and mineral lineation. Where this structure is present, the core has a distinctive appearance, and will show bands of differing colour, texture or mineral reflectivity – each representing a different range of surface to lineation intersection angles – running along the length of the core. Those lineations that have the smallest cross sectional area on the core surface (line A of Fig. 7.5c) represent the lineations that pass through the core axis and have the highest angle intersections with the core surface. This line of intersections on the core surface is often rough, poorly reflective and shows as a dark band. By contrast, the line of low-angle intersections is often marked by a smooth and light reflecting band along the core surface. When a penetrative mineral lineation is not well developed, or the defining minerals are fine grained or not otherwise distinctive, it can often be detected by looking at a low angle along the core surface, while slowly tilting it back and forward below a bright light (Fig. 7.6). As the core is moved, the crystal faces of mineral grains whose long axes are parallel to the core surface, will often give a glint or flash of reflected light, thus revealing their preferred orientation.<sup>8</sup>
4. The axes of cylindrical folds are a special type of non penetrative linear structure. Because folds are so important, their appearance in core is treated in a separate section.

<sup>8</sup>The same technique is useful for detecting cryptic minerals present in any hand specimen.

**Fig. 7.6** How to find a fine-grained penetrative mineral lineation in core. As the core is slowly tilted at a low angle to a strong direct light, crystal faces of elongate minerals that parallel the core surface will often reflect a flash of light, thus revealing their preferred orientation (see also Laing, 1991, *Structural geology in exploration and mining*, unpublished)



### 7.6.5 Folds

Fold axes are defined by the line joining points of maximum curvature (an inflection line) on the folded surface (Huddleston, 1972). Where a fold is intersected by drill core, the core surface will show two fold inflection points: one where the fold axis enters the core, and one where it exits. As explained above, each planar limb of the fold is also defined by two inflection points that represent the ends of the long axis of the intersection ellipse for the surface. With all these inflection points, the trace of a folded bed on the surface of core can therefore have quite a complicated appearance and identifying the position and orientation of the axes of folded surfaces in drill core therefore requires some care.

The simplest case comprises those folds whose axes are oriented at right angles to the core axis. Here the inflection lines for the two fold limbs (and for any axial-plane cleavage present) will all coincide and lie at right angles to the fold axes (Fig. 7.7). By looking at right angles to the core surface, the true profile shape of the fold can be observed.

In the more general case, where fold axes are not normal to the core axis, the inflection lines for the two fold limbs and the axial-plane cleavage do not coincide. This produces a complex asymmetric fold shape on the core surface (Fig. 7.8). In order to distinguish the fold axes from the inflection points for the two fold limbs, it is necessary to carefully trace the folded bed right around the core. No view of the core gives the true profile of the fold, although, by looking along the fold axis, and allowing for the effects of foreshortening, some idea of the true fold profile shape can still be obtained.

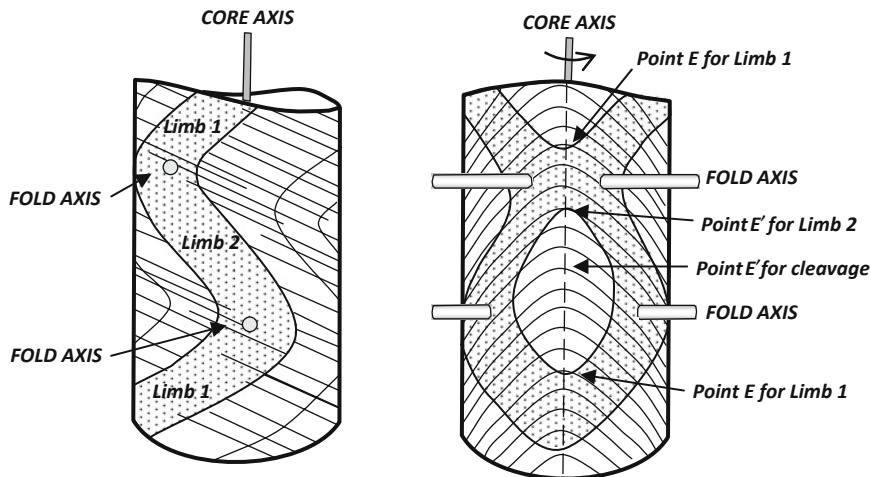

**Fig. 7.7** How folds look in core when the fold axes are normal to the core axis. In the illustration, a bedded sequence defines a small fold pair. There is a strong penetrative axial plane cleavage that bisects the fold limbs. Inflection lines for the two fold limbs and the axial plane cleavage coincide and are symmetrical about the fold axes

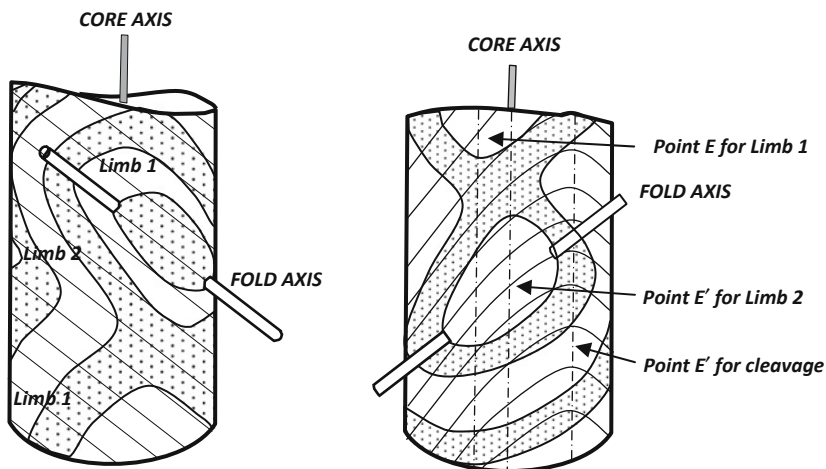

**Fig. 7.8** How folds look in core when fold axes are not normal to the core axis. In this example, the same fold pair illustrated in Fig. 7.7 is intersected by a drill hole that is oblique to the fold axes. This results in a complex trace of the beds on the core surface. Inflection lines for the two fold limbs and the axial plane cleavage do not coincide and are asymmetrical with the fold axes

**7.6.6 The Scale Problem**

In a small piece of drill core it is relatively easy to see small or close-spaced structures, but structures which are significantly larger than the diameter of the core can

be hard to recognise. For example, a strong axial plane cleavage may be very obvious in core, but this may obscure a folded bed that lies at a high angle to the cleavage (Fig. 7.9). In outcrop, the solution to this problem is to step back, let the busy foreground detail go out of focus, and view a larger area of the outcrop. In drill core, this is not so easy, but so long as the geologist is aware of the problem a solution can be attempted. One method is to observe the structures present in the less deformed sections of the core, and examine the nature of the transition to the more deformed parts of the core. Another way is to do what one would do at an outcrop, standing back from the core and attempt to see any larger structure that may be present. Sometimes the large structure is only apparent when a detailed log for the entire hole is plotted on to the drill section, and comparisons made with adjacent holes. When a large fold structure is suspected, detailed re-examination of the core will often yield the subtle indirect evidence for its presence, which might have been missed in the first-pass logging.

Small structures often give a reliable indication of the style and attitude of associated larger structures. This relationship (mentioned above in relation to minor faults) has long been known to geologists as “Pumpelly’s Rule” after Raphael Pumpelly<sup>9</sup> the USGS geologist who first enunciated it (Pumpelly et al., 1894, p. 158). The relationship is now appreciated as a fundamental feature of many non linear systems, and is referred to as “scale dependent self similarity”, or more simply as a fractal relationship (from “fractal dimension” see: Blenkinsop, 1994; Mandelbrot, 1983). Whatever it is called, such relationships can provide very valuable clues for resolving structure of large size from the evidence of small structures seen in drill core or outcrop.

**Fig. 7.9** Because of the small size of drill core, identifying large structures is difficult. Here a strong cleavage in a fold hinge obliterates earlier bedding surfaces in a small piece of core. Only by carefully observing progressive changes over a longer section of core can the true structure be identified

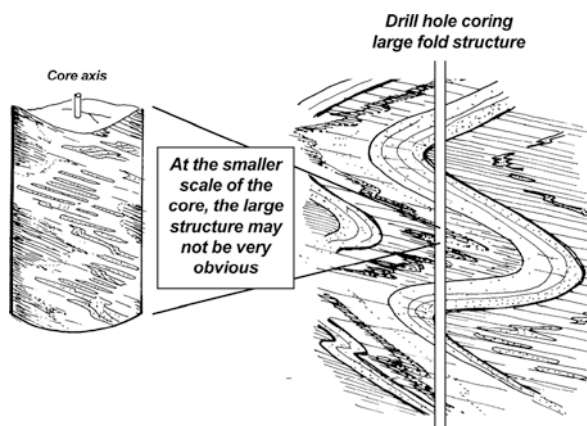

<sup>9</sup>He also had the mineral pumpellyite named after him.

As a general rule, and this applies to any type of observation, the best way to recognise subtle features in a rock is to be aware of the possibility that such a feature might be present, and then actively look for it. The famous nineteenth century French scientist Louis Pasteur put the same idea well in 1854: “Where observation is concerned, chance favours the prepared mind”. Good observation has nothing to do with good eyesight.

### 7.6.7 Vergence

Vergence is the name given to the systematic changes in the symmetry of small structures about the axis of a large fold.<sup>10</sup> Recognising and recording structural asymmetry in outcrop or drill core can allow deduction of the approximate position and geometry of the larger structure. Structures from which vergence information can be gained are fold pairs (either S-shape or sinistral; Z-shape or dextral) or the sense of angular relationship between bedding and cleavage (once again described as dextral or sinistral). Note that, by convention, the terms dextral and sinistral refer to an angular relationship as it appears looking down on the structure. When viewed from below, the sense of asymmetry is reversed. For example, a sinistral (S shape) fold pair becomes dextral (Z shape) when viewed from below. This means that vergence relationships can only be recognised in oriented core.

Structures showing vergence relationships are readily seen in drill core and, if the core is oriented, can be used to provide valuable data on the style, position and geometry of larger scale folding. Even if the core is not oriented, some aspects of changing vergence relationships can still indicate that a major fold axis has been crossed. For example, cleavage at a high angle to bedding indicates a position on a fold hinge: cleavage at a relatively low angle to bedding indicates a position on the fold limb. However, if the core is oriented, the vergence observations can also indicate whether the large fold that has been crossed is an antiform or a synform, as well as providing data on the geometry of the fold itself (Fig. 7.10).

Once a vergence determination has been made, it can be recorded on the log or drill section as a vector (an arrow) pointing up the hole or down the hole towards the adjacent large antiform. Arrows pointing towards each other on the hole trace will thus indicate the position of a map scale antiformal axis. Arrows pointing away from each other will then indicate the position of a synformal axis.<sup>11</sup>

---

<sup>10</sup>For a discussion and explanation of the use of vergence in structural geology, the reader is referred to any good structural geology textbook, such as Wilson (1961) or Hobbs et al. (1976).

<sup>11</sup>An antiform is any upwards-closing folded surface. A synform is any downwards-closing folded surface. The terms anticline and syncline can strictly only be used when describing sedimentary sequences where the original stratigraphic top of the sequence is known. Thus in an anticline beds become older towards the centre of the fold. In a syncline, beds become older away from the centre of the fold.

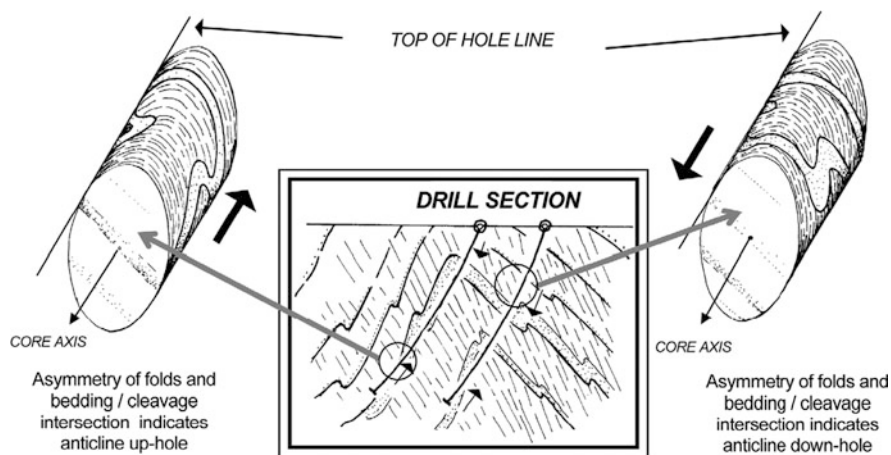

**Fig. 7.10** Using the angular relationships between bedding and cleavage (vergence) in oriented drill core to define large, prospect scale, antiformal or synformal folds. A *small arrow* plotted beside the drill trace on section indicates the direction to the adjacent antiform. *Opposed arrows* show that a fold axis has been crossed in the hole

## 7.7 Measuring and Recording Structures in Core

Down-hole orientation surveys record the deviation of a hole from its initial azimuth and inclination (Sect. 7.2). However, the solid stick of drill core (sometimes, not so solid) recovered from a hole is not fully oriented by a down-hole survey. Although the azimuth and inclination of the core axis is known, it has another degree of freedom in that it can rotate about its long axis. This does not affect a lithological log made of the core (the down-hole depth to any given point on the core can still be measured), nor the ability to measure true thickness of beds (Fig. 7.14), but the original attitude of structures cannot be directly determined. However, techniques are available to fully orient the drill core.

In many cases rocks contain a penetrative planar fabric such as bedding or cleavage whose orientation is known from surface mapping. In these cases, if this surface can be identified in the core, and the assumption can be made that its attitude is constant, the surface can be used to orient the core. A cleavage is a better surface to use for this than bedding because the attitude of a cleavage is generally more constant than that of bedding (Annels and Hellewell, 1988). Once the core is oriented by this means, other structures present can be directly measured. How to do this is fully set out in Appendix B.

A common situation occurs when a hole is drilled at right angles to the strike of a planar structure whose dip is either not known or else is suspected of changing through the length of the hole, perhaps as the result of folding. This is a situation that often arises when drilling surface geochemical or geophysical anomalies. All that can be measured is the angle  $\alpha$  – the angle that the surface makes with the long axis of the core. Since in this case the strike is either known or can be confidently

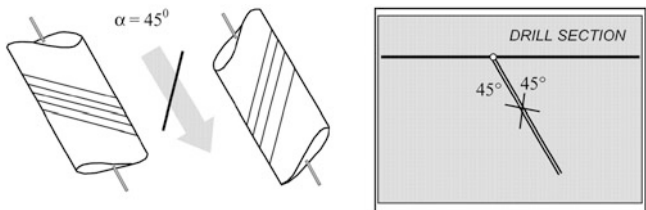

**Fig. 7.11** How to plot the attitude of surfaces in non-oriented core where the strike of the bed is known, but the dip is not (i.e. assuming the hole azimuth is normal to strike). Of the two possibilities plotted, one can often be discarded as unlikely

assumed, the surface can be plotted on the drill section in only two possible attitudes, that is, symmetrically disposed at angle alpha about the hole trace (Fig. 7.11). In many if not most cases, simple inspection of the two geometric possibilities for the attitude of the measured surface will lead to one of them being discarded as unlikely.

In the general case where the strike of a surface seen within the drill core cannot be assumed, then the angle between that surface and the core axis ( $\alpha$ ) defines half of the apical angle of the cone that would be produced if the surface were rotated around the core axis. This is illustrated in Fig. 7.12, where the different possible attitudes of the surface on rotating the core about its axis are shown. In this case, no absolute measurement of the attitude of the surface is possible, but it is still worthwhile to plot the boundaries of the cone of lines on to the drill section to represent the limits to the range of possible solutions to the true orientation of the surface.

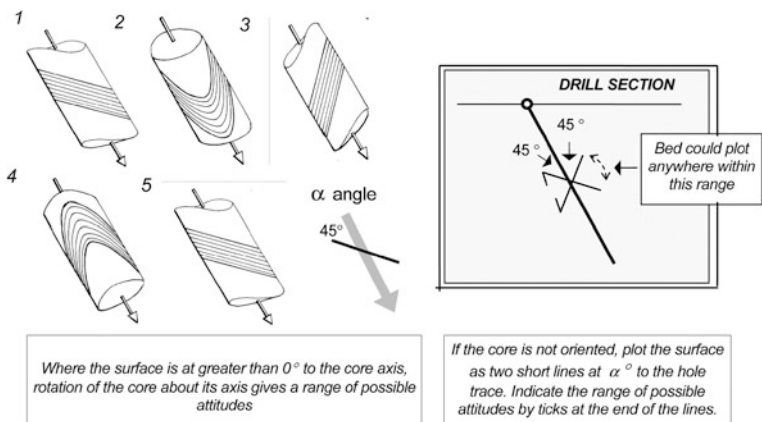

**Fig. 7.12** How to plot the attitude of a surface where neither its strike nor dip is known. On the trace of the drill hole on section two lines with ticks indicate the range of possible attitudes defined by the alpha angle

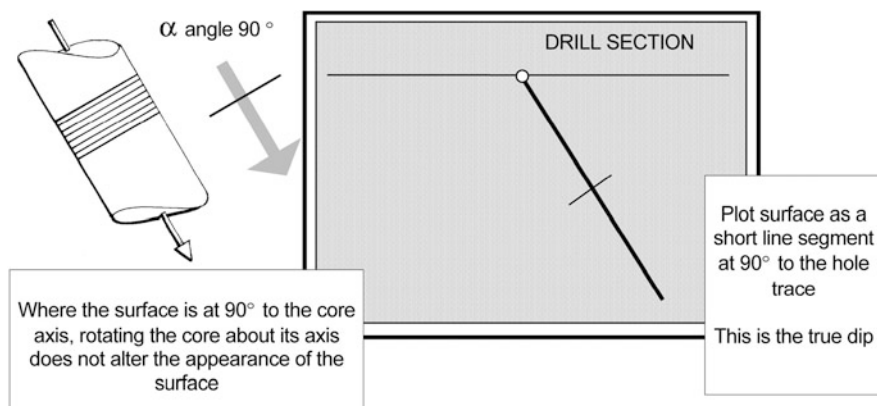

**Fig. 7.13** How to plot the attitude of surfaces in non-oriented core where the surface is at  $90^\circ$  to the core axis ( $\alpha = 90^\circ$ ). This situation can only arise when drilling at right angles to strike. The dip shown on the section is therefore a true dip. However, the core is still not fully oriented, as the attitude of any surfaces not at  $90^\circ$  to the core or any linear structure still cannot be measured

A special case exists where the surface seen in core is exactly normal to the core axis. In this case, rotation about the axis gives no apparent change in attitude of the bed. The surface can therefore be plotted directly on to the drill section as a short line at right angles to the hole trace (Fig. 7.13). However, note that the core is still not oriented, and other planar or linear structures that might occur within it (that are not normal to the core axis) cannot be measured.

For the general case where no assumptions can be made about the attitude of structures in the core, absolute measurement can only be made if the core is mechanically oriented by means of a core-orienting device. The specialized procedures involved in handling and measuring oriented core are fully described in Appendix B.

Even where core is not oriented, it is still possible to make a large number of useful structural observations and measurements. For example:

- Qualitative observations on the style and nature of structures.
- The relative ages of structures and their relationships to lithology, veining and alteration.

The only quantitative structural measurement possible in non oriented core from a single drill hole is the alpha angle. Taking and recording alpha angles for planar structures is quick and easy to do and should be a routine procedure in all core logging. From the alpha angle is possible to use simple trigonometry calculate the true thickness of any tabular bed or vein intersected by the core. How to do this is illustrated in Fig. 7.14.

If a distinctive and unique marker surface is intersected in a minimum of three drill holes, then the coordinates (northing, easting and height above datum) for each intersection can be used to calculate the strike and dip of the surface. This situation



**Fig. 7.14** How to calculate the true thickness of beds in core. All that is needed is the alpha angle. It is not necessary for the core to be oriented, or even to know the hole azimuth and inclination

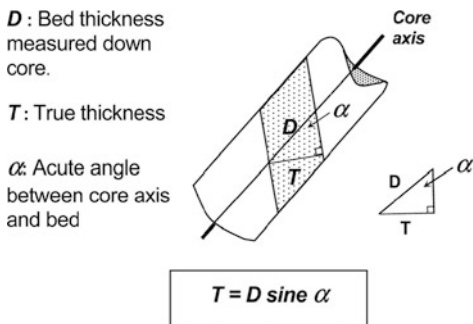

is frequently encountered in drilling programs and is referred to as the three-point problem. The solution is set out fully in Appendix C.

Where there is no single marker bed that can be correlated between adjacent drill holes it is sometimes still possible to determine the orientation of a set of parallel surfaces (such as bedding planes, a cleavage, or a vein set) provided the surfaces have been cored by a minimum of three non parallel drill holes (Mead, 1921; Bucher, 1943). The same technique has even been extended to a single hole, provided the hole has sufficient deviation along its length for the differently oriented sectors of the same hole to be considered in the same way as three separate holes (Laing, 1977). The solution involves an elegant stereo net procedure: how to do it is described fully in Appendix C.

## 7.8 Core Logging Systems

The way data are to be recorded influences in a significant way the amount and type of data that are observed.<sup>12</sup> Using the most appropriate system for recording geological observations of drill core is therefore very important. Although a huge number of different logging forms are used in industry (almost every exploration group has its own design), there are only three basic methods for recording observations on drill core and cuttings. All individual logging systems correspond to one or other, or a combination, of these basic methodologies. The three logging styles are characterized here as prose logging, analytical spread-sheet logging and graphical scale logging. They are described below.

### 7.8.1 Prose Logging

In prose logging, an interval is selected, identified by its down-hole depth limits, and then described in words. Such a log will look like the example of Fig. 7.15.

<sup>12</sup>This is a good illustration of the aphorism – “The Medium is the Message” – coined by Marshall McLuhan (1964).

DEPTH	DESCRIPTION
123.45 - 136.9	<i>Sandstone with calcareous cement. Pale khaki colour with a medium, somewhat gritty grainsize. Bedding defined by thin shale partings at 123,34m 126.58 &amp; 132.12 also pebbly band at 128.4m. Bedding at generally 45° to LCA but becomes a bit flatter to end section. Numerous thin wispy qtz veins assoc. with pyrite speckling along really distinct margins (looks a lot like the last hole). You can see a weakish cleavage in places but mostly its not there..</i>

**Fig. 7.15** An example of the prose style of recording geological observations of core or cuttings. An interval is selected, defined by precise down-hole depth intervals, and then described in words. It is generally difficult to extract precise, objective information from such logs and they are tedious to read. The style is not recommended

Words are a powerful means of summarizing conclusions and prose is an invaluable way to present an argument, give an explanation or provide a discussion. However, long passages of prose are a laborious and ineffective way of recording the complex spatial relationships that can exist between the observable features of a rock. It is also unlikely that any two geologists would ever describe a rock using quite the same words. This means that extracting precise and objective information from a prose log, so as to construct a drill section or to understand the relationships seen, is difficult and time consuming. As a general rule, literary efforts should be reserved for report writing and not be used as a means of routine core description. It is therefore recommended that this style of logging be only used, if at all, in a special “Comments” column to provide brief verbal commentaries to complement one of the other two logging styles.

### 7.8.2 Graphical Scale Logging

Initial stage drilling needs to make use of a logging system that permits and encourages detailed observation and presents the information in a manner that aids interpretation. Pre-eminently, the best recording system for this is graphical scale logging. In such logs, a down-hole strip map is made of the core at some chosen scale, say 1:100. Structures are simply drawn onto the map in the attitude that they appear in the core. For example a 50 cm vein, which cuts the core at 45°, will be drawn (at 1:100 scale) on the core map as a 5 mm wide vein at 45° to the core trace. Different columns of the pictorial log (different specialised maps) can be allocated for different features of the core: for example there could be separate columns for lithology, alteration, veining and structure. An example of this type of logging is shown in Fig. 7.16. All the columns are linked horizontally on the log by

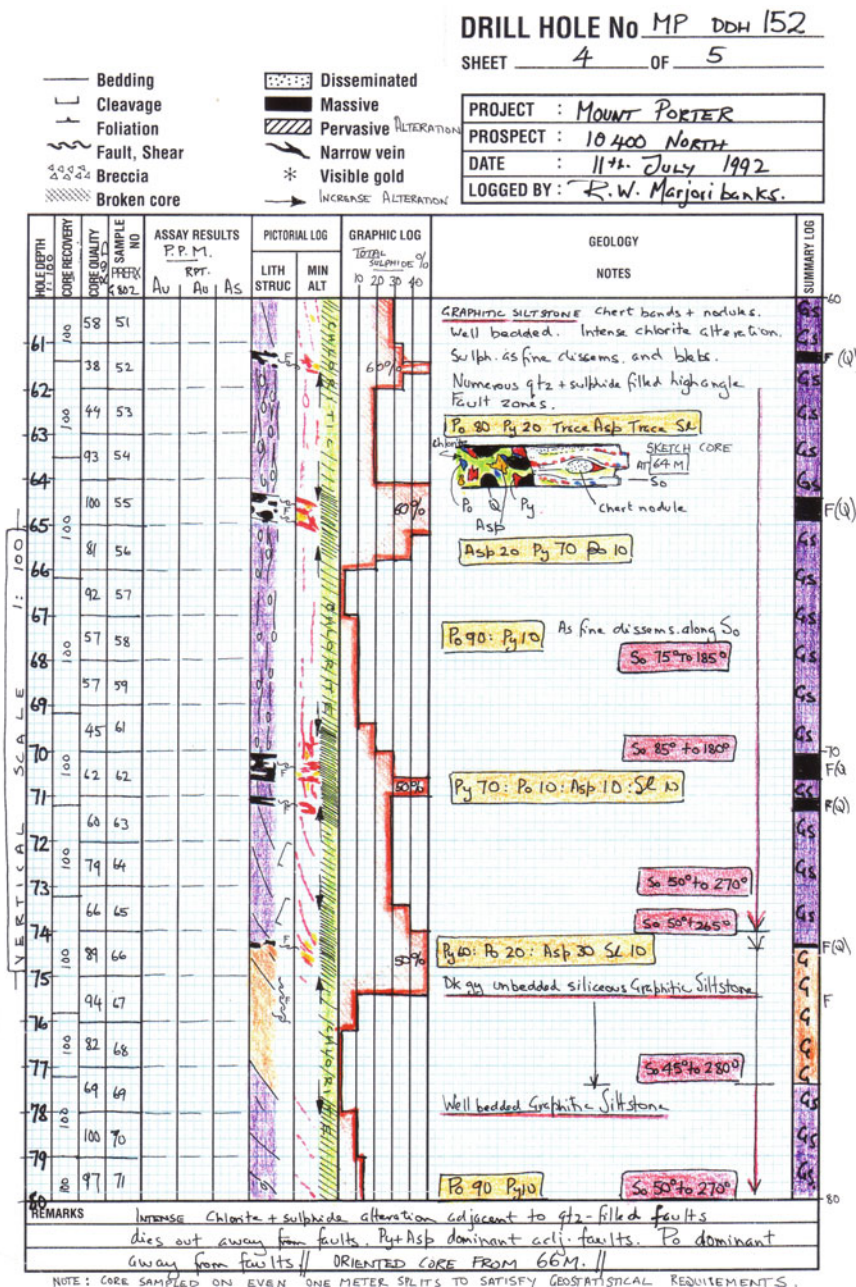

**Fig. 7.16** An example of the use of graphical scale logging of core. Observations are recorded graphically and numerically on the log sheet against a selected down-page scale. The use of colour on such logs greatly enhances information content. Graphical logging is a powerful and flexible technique which supports detailed observation: its use is recommended for all first stage exploration drilling. A detailed description on this log form will be found in Appendix A (Refer Color Plate 1 at end of book)

being drawn to a common vertical down page (down hole) scale. When using such a log, different features can be given different down hole depth ranges, and it is also possible to indicate gradational contacts in a simple graphical manner. Further illustrations of graphical techniques that can be used in this type of logging are shown in Fig. 7.17. An example of graphical scale logging (tailored for use in logging volcanic sequences) can be found in McPhie et al. (1993).

Obviously, not all observations or measurements that can be made on core can be shown graphically, so a graphical-scale log sheet should also provide extra columns for recording digital data or for making verbal annotation, description or comment of the rock or structure. Data relating to the frequency of some structural feature (for example: number of fractures per metre or percent vein quartz per meter) can be shown as a down hole histogram. If the core is oriented, individual structural measurements are recorded directly as strike/dip/dip direction onto a column of the form. If the core is not oriented, alpha angles (see Sect. 7.7) can be shown graphically (analog recording) in the mapping column, but can also be recorded digitally in a separate column. Important details of structures or structural relationships that are too small to be shown on the core maps, can be sketched into an unspecified, or “Comments” column.

Graphical scale log forms, with several mapping columns along with extra columns for recording digital data, sketches, verbal comment etc. can be as varied as the number of prospects that are being drilled. However, the important feature about all such logs is that they assemble many different types of geological observation on one form linked by a single down page scale. All important relationships, but especially spatial relationships, can thus be seen at a glance. Graphical scale logs such as described above are a powerful tool in helping to understand geology and to correlate structures between holes. However, there is no doubt that such logs are slow, even tedious, to prepare, and they are unsuitable for the intense drilling programs of more advanced prospect exploration. Once an understanding of the geology of a prospect has been gained (this may be after the first 1–2 holes or after the first 10–20 holes, depending on the complexity of the geology and the quality of the initial geological input), a simplified, more focussed and objective, logging process is appropriate. That system is analytical spread sheet logging.

More information on using graphical scale log sheets, and a detailed explanation of Fig. 7.16, will be found in Appendix A.

### ***7.8.3 Analytical Spreadsheet Logging***

Use of spread-sheet logging is indicated in second-phase drilling programmes (resource evaluation and definition) where the main geological problems associated with the ore body have been solved, and the aim of the logging is the routine recording of masses of reproducible data. It is also an ideal technique for recording geological data obtained from rotary percussion (RAB and RC) drill cuttings. In these holes, observations already come pre-divided into 1–3 m slices, and the range of possible geological observation is limited.

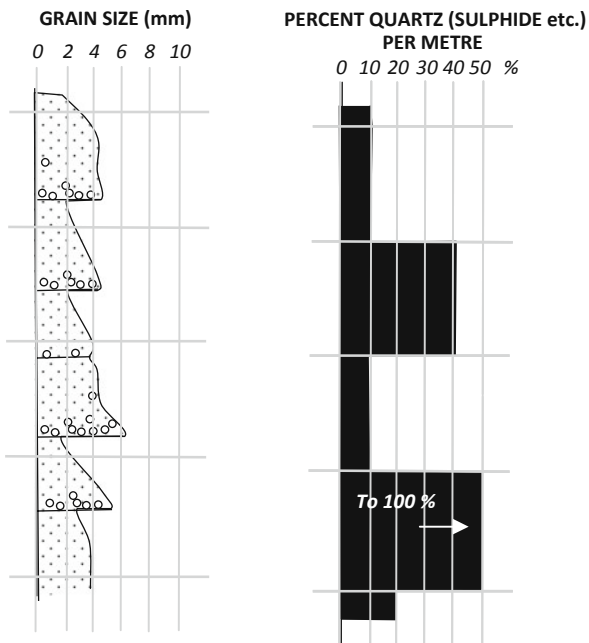
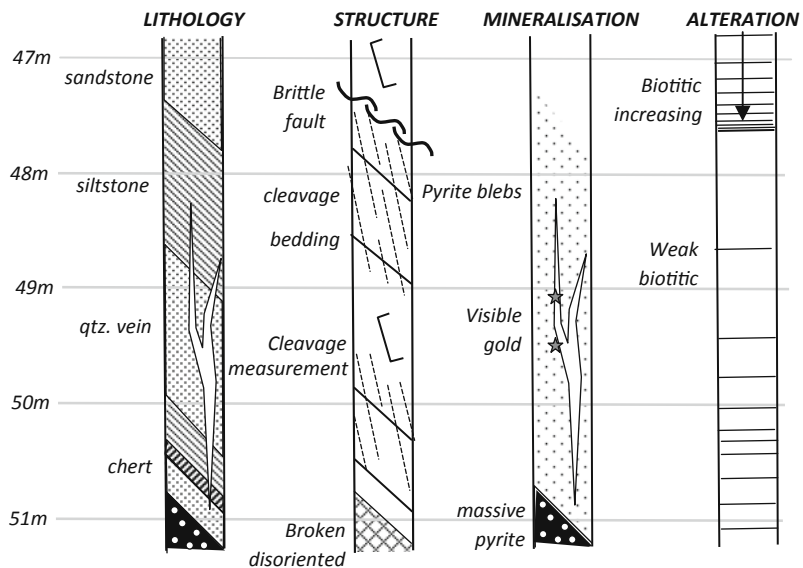

Fig. 7.17 Examples of symbols that can be used in graphical scale logging

In analytical spread-sheet logging,<sup>13</sup> the characteristics of the rock are described under a number of precise, prior-defined categories such as colour, grain size, mineral content, number and type of veins, type of alteration, intensity of alteration etc. . . For descriptive purposes the rock is thus reduced (analysed) to its individual components. These descriptive parameters form the headings for the columns of a spread-sheet. The rock is then described under selected depth intervals that form the rows of the sheet. To keep the log compact and precise, symbols, standard abbreviations and numbers are used whenever possible to record this information. This is known as geocoding. The setting up of a system of geocoding symbols to allow entry of geological observations into searchable geological database is an important subject that will be further discussed in Sect. 10.2.

An analytical spread sheet log will look something like the example of Fig. 7.18. This is a simplified example: an actual log would in most cases provide many more columns allowing greater detail of description.

The great strength of this style of logging is that it precisely defines the type of data to be recorded and presents them in a standardized and easily accessible format. All geologists logging the same section of core should produce much the same log. In addition, the spread-sheet log is ideal for direct computer entry of data as observations are made, and it is compatible with electronic data storage and geological presentation software. All the possible observations which can be made in each column of the log can be printed out in advance, along with a bar code. If these pages (usually laminated) are kept to hand during logging, a simple swipe of a barcode reader can then instantly enter data into a portable notebook or palm-top computer.

In spite of these advantages, the problems associated with spread-sheet logs can be extreme. They set limits to the range of possible observations that can be made. There is an obvious danger inherent in defining the categories of observation, and the ranges within each category, before logging takes place. Even more importantly, such a format provides no really satisfactory way to record the relationships between the different categories of observation. In addition, the horizontal rows on the log sheet only allow for definition of observed characteristics between precise depth limits whereas, in reality, many features in a rock will vary in a gradual way, and different features that need to be described may vary at different rates, or have different down-hole depth ranges.

On spreadsheet log forms, structural observations are usually recorded by a standard symbol for the nature or age of the structure (for example:  $S_0$ ,  $V_1$ ,  $F_2$  etc. – representing respectively: bedding Surface, 1st generation Vein, 2nd generation Fold etc.). The structure symbol is combined with a column or columns where the measured internal core angles for the structure (alpha, beta – see Sect. 7.7 and Appendix B) are digitally recorded. Most analytical spreadsheet log forms will also

---

<sup>13</sup>This type of logging has been referred to as fixed-format logging using alpha-numeric codes. The term used here is considered to better reflect the methodology behind this system.

Logged by: R. MARJORIBANKS		Date: 14/10/96		Sheet: / Of: /		Hole No: H/D 228							
LITHOLOGY				TEXTURE	GRAIN SIZE	ALTERATION	OXIDATION	STRUCTURE SYMBOLS (Graphic Log)					
Ab Metabasalt	Gs Metagabbro	Pf Feld Porphy	Pg Pegmatite	Hornblende A, Amphibole Q Quartz	m - massive	p - pagmatitic	l - fine	l - weak	Ok - complete				
Am Metafelsic basalt	Pq Quartz Porphyry	L Lode	D Diolite	B Biotite	E Epidote	Gt Garnet	s - schistose	c - coarse	a - aphanitic	o - moderate	f - fresh	li - partial	lithological contact schistosity ductile shear brittle fracture zone breccia broken core
Ag Garnelliferous Ab	Ph hornblende Porph	Gr - Granite	S - Saponite	S - Sericite	Fd Feldspar	C Carbonate	b - banded	m - medium	o - intense	F - fresh			
Metres	Recov	Oxid	Lithology	Texture	Grain	Alteration		Mineralisation		CLEAVAGE		Comments	SUMMARY
						Size	Biotite	Sericite	% S	% Q vein	Angle		
0	65											PRE COLLAR	
65	74		Tr Ab	f-m						35			Ab
74	78		F BS-SB	s	F-m	3	3			35			Ab(alt)
78	80		Ab	s,b	f	2	2	-	-	30		black "spots" to 10mm Possible CORNER, etc	Ab(alt)
80	90		Ab	m-s	f	1-2	-	-	-	30			Ab
90	92		L	s,b	f	3	3	30	10				L
92	102		Ab	s,b	f	3	3	5	-	40			Ab(alt)
102	117.5		L	s,b	f	3	3	5-30	10	40			L
117.5	125		Ab	s,b	f-m	1-3	1	-	-	35			Ab
125	148		Ab	m	f	0-1	-	-	-	35			Ab
148	153		L	b,s	m	1	3	20	5	40			L
153	156		SB	s	f	-	3	-	5	45			SB
156	180		Ab	m-s	f	1-2	0-2	-	-	35			Ab.
	EOH												
Prospect / Mine:		Collar: 9800 (r)N; 5025 (r) E		Inclined 60° To WEST		TWD		General:					

**Fig. 7.18** A simple example of the analytical spreadsheet logging style. Observations of core or cuttings are broken down (analysed) into a number of objective pre-defined categories (the columns). Selected down-hole depth intervals (the rows) are then described under these categories. Numbers, abbreviations and symbols, according to a pre-defined geocoding system, are used wherever possible. The log aims to provide objective, reproducible and easy to access information and is suitable for direct entry into a computer. The system is ideal for logging rotary percussion drill holes, for mine drilling and for the advanced definition drilling stages of an exploration programme

provide an unstructured “Comments” column, where verbal annotation, qualification or comment about the structure can be added.

## 7.9 Down-Hole Surveying

### 7.9.1 Procedure

The orientation of a drill hole is defined by its azimuth and inclination (Sect. 7.2). Azimuth and inclination, along with collar coordinates and collar height above a datum (relative level or RL) are part of the commencing specifications for a drill hole. However, because a string of drill rods is not rigid, the attitude of the hole can progressively change with depth – this is called deviation. In the majority of cases holes flatten (because of downwards drilling pressure) and swing to the right (with the turning of the rods), but this is not always the case. Holes will tend to deflect so as to make a greater angle with the dominant foliation (usually bedding or cleavage) of the rock, unless the hole is already at a very low angle to that foliation, in which case the hole will tend to deflect along the foliation. Only experience of drilling in a particular area can allow exact prediction.

Although deviation is at most only of the order of a few degrees per hundred metres, this is usually cumulative and, if not allowed for, the bottom of a deep hole can be many tens of metres away from its straight-line course. The expected deviation of the hole needs to be allowed for when designing a drill hole to intersect a particular target at depth.

Generally, holes over 50 m deep need to be surveyed to determine the amount of deviation. The instrument usually employed to do this is a specially designed down-hole survey camera. With a single shot instrument, the camera, housed in a special brass or aluminium case, is lowered down the hole to the required depth on the end of the wire-line overshot. After a predetermined time, a clockwork mechanism activates the camera to take a photograph of a small built-in compass card and clinometer. On processing, a photographic record is obtained of the orientation of the hole at that depth. With a multi-shot bore-hole camera, the mechanism can be set to take a number of readings at predetermined times, thus allowing orientation measurements at different depths to be obtained as the instrument is withdrawn from the hole. An oriented hole is one in which a down hole survey has been conducted to determine the exact azimuth and inclination of the core axis at a number of points down the hole.

Results from the down-hole camera are generally very accurate, but care has to be taken with the following points:

- The survey instrument should be isolated from the steel drill stem that can affect the compass needle. The drilling rods and bits have to be pulled back from the bottom of the hole, to allow the brass or aluminium casing of the down-hole camera to project at least 3 m beyond them at the time of the survey,



- Magnetic rock units may affect the compass. Such effects can usually be spotted if one azimuth reading is out of phase with measurements on either side. This reading should be discarded.
- If long sections of the hole are magnetic then the magnetic-field based down-hole survey camera cannot be used for azimuth determinations. In this case it may be possible to measure the attitude of the hole from the angle that the core makes with known planar features of the rocks, such as bedding or cleavage. Failing that, it is possible to orient holes using gyroscope-based instruments, but these are not always readily available and are generally expensive.
- Do not use steel-jacketed batteries to power the survey instrument as these are magnetic and can affect the compass.

When drilling in a new area, surveys should initially be carried out every 30–50 m down hole, but if experience indicates that there is no strong deviation, this interval may be subsequently increased. Drillers carry out the down-hole survey on the instruction of the geologist.

As soon as they are obtained, the down-hole survey data should be used to construct a section and plan view of the hole (see below, Sect. 7.9.2). By doing this, the progress and effectiveness of the hole in reaching the planned target can be monitored. If strong deviations are encountered, the driller can be alerted to the problem, and it may be possible to take corrective action.

### ***7.9.2 Using Down-Hole Survey Data to Plot Sections and Plans***

Nowadays, once down-hole survey data have been entered into a computer, the task of plotting the trace of the hole onto a section or a plan is usually taken care of by one of the many mining/exploration software programs. However, in first phase exploration drilling, plotting geological observations on a daily basis usually means that the geologist's working section will have to be plotted by hand. How to do this is set out below.

Changes in inclination and azimuth record a downwards spiralling of the hole. This appears as a curved trace on both plan and section views of the hole (Fig. 7.19). The curved trace on plan view means that data have to be projected horizontally to create the drill section. However in the early stages of exploration drilling, where the exact position (i.e. to the nearest few metres) of the hole in space is not especially relevant, changes in azimuth can usually be ignored and it is only necessary to plot a section of the hole recording changes in inclination. A section like this is quick and easy to draw and, provided changes in azimuth are not too extreme, is adequate for most initial plotting and interpretation of geology.

The effects of deviation are progressive, so with deep holes (say, over 300 m depth), particularly where large azimuth deviations are encountered (more than 5° per 100 m), the simple drill section plot described below will tend to be increasingly inaccurate and a plotting procedure that allows for the simultaneous changes

**Fig. 7.19** How to prepare an exact drill section and plan from the results of down-hole orientation surveys. The plot illustrated is based on the survey data of Table 6.1

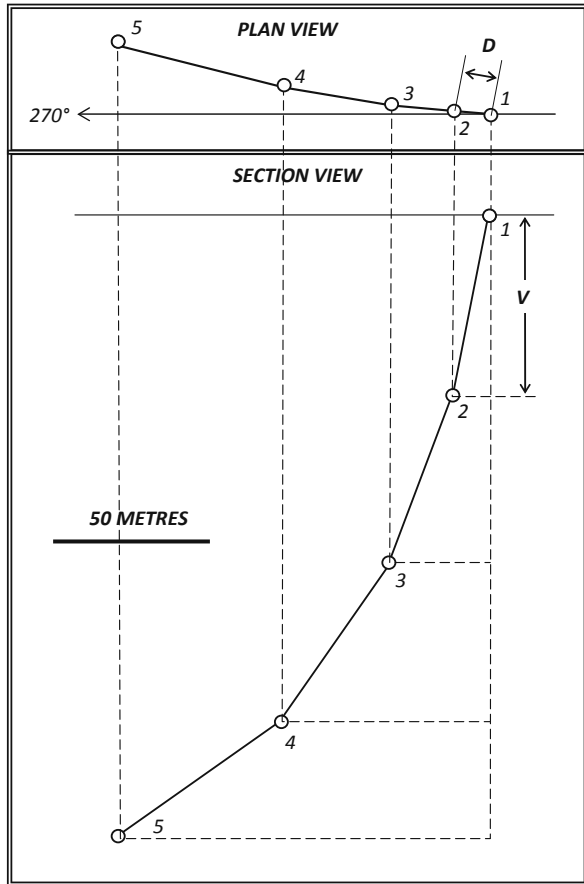

in inclination and azimuth is necessary. This more complicated procedure will also be necessary if the trace of a hole has to be projected orthogonally on to any section that is at an angle to the standard drill section. Both the simple (but approximate), and the more complex (but exact), procedures for plotting drill sections and plans are described below, using the set of hole survey data in Table 7.1.

**Table 7.1** Down-hole survey data

Survey point	Depth (m)	Inclination (°)	Azimuth (°)
1	0	70	270
2	52	66	280
3	106	64	288
4	160	62	290
5	205	58	296

### 7.9.2.1 Plotting an Approximate Section

1. From the surface (Survey Point 1) to Survey Point 2 at 52 m down hole depth, the hole flattened from 70 to 66°. The average inclination for this sector of the hole is therefore 68°.
2. Using an appropriate scale, a point is plotted on the section representing 52 m from the starting point (hole collar) at an angle from the horizontal of 68°.
3. In a similar manner, Survey Point 3, at 106 m down hole, is 54 m (106–52 m) from Point 2 at an inclination of 65° (the mean of 66 and 64°); Point 4 is 54 m from Point 3 at an inclination of 63°, and so on to the end of the hole. A smooth curve joining the plotted points will be a close approximation to the actual trace of the hole.
4. In this example, ignoring the azimuth variation means that there is a progressive error in the position of the hole on the drawn section which amounts to around 5 m by the bottom of the hole (10 mm at 1:500 scale).

### 7.9.2.2 Plotting an Exact Plan and Section

1. On the same sheet, draw both the plan and section views of the hole, with the collar position on plan and section vertically aligned on the page (see Fig. 7.19). Sections can now be drawn at any angle required to the trace of the hole; the one illustrated is parallel to the starting azimuth of the hole.
2. From Survey Point 1 (the collar of the hole) to Survey Point 2, the down-hole distance is 52 m, the mean azimuth is 275° (the average of the starting azimuth and final azimuth), and the mean inclination is 68°.
3. Using trigonometry, the horizontal (D) and vertical (V) distances between Points 1 and 2 are calculated:

$$D = 52 \times \cos 68^\circ = 19.48 \text{ m}$$

$$V = 52 \times \sin 68^\circ = 48.2 \text{ m}$$

4. Using a suitable scale, on plan view, plot Point 2 at 19.48 m from Point 1 at a bearing of 275°.
5. On the plan, draw a line from Point 2 to intersect the trace of the proposed section at right angles. From this intersection point, draw a vertical line down the sheet and across the section below.
6. Survey Point 2 is now plotted on the section where the line marking 48.2 m vertically below surface intersects the vertical line projected from the plan view above. The same scale is used for plan and section.
7. The same procedure is used for plotting each successive down-hole survey point. A smooth curve through the points will give an accurate trace of the drill hole on plan and section.

## 7.10 When Should Core Be Oriented?

Ten or more years ago, at the time the first edition of this book was published, orienting core was uncommon, and a large amount of useful data on the orientation of structures was lost. Today, core is often routinely oriented, at considerable cost in time and money, even in cases where there is really no need for this procedure. It is therefore useful to consider the circumstances when core orientation is required.

When drilling in an area of good outcrop, where the rocks have a simple pervasive fabric of constant known attitude, it is generally not necessary to orient drill core. The orientation of the known structures in the core (for example, regular bedding or cleavage surfaces) can be used to orient the core, thus enabling other features whose orientation is not known (for example mineral veins) to be measured. How to do this is dealt with in Appendix B.

When drilling in an area of poor or no outcrop, the first few drill holes may be all that is necessary too establish the orientation of a dominant fabric and make orienting subsequent holes unnecessary. However, where structure is complex and variable, it may be necessary to orient the core from every hole drilled in the area.

Core orientation is carried out on a drilled run or barrel of core. If the recovered rock is relatively unbroken, with little core loss, and the broken ends of the core pieces can be matched and reassembled across several barrels of core, it may only be necessary to orient every second or third run of core. Where there is broken core, core loss and difficulty in achieving good orientation marks, it is necessary to attempt to orient every barrel of core. However, since the decision to orient a run of core has to be made before it is pulled from the ground, and the condition of the core is generally only known after it has been extracted, it is always better to err on the safe side and attempt orientation of as many barrels as possible. Once a few holes have been drilled, knowledge of the condition of the core should enable a decision to be made on how frequently it will be necessary to attempt orientation of subsequent holes.

Oriented core requires special handling and marking out procedures before the geologist is able to measure structure. These procedures are explained in Appendix B.

## 7.11 Sampling and Assaying

Assaying diamond drill core during the early phases of exploration has two purposes. The first is to provide an indication of whether potentially mineable grades are present. The second is to give an understanding of where economically significant elements are reporting in the system, so that controls on ore distribution can be defined and understood. This understanding is necessary in order to target new holes.

In first-phase exploration drilling, the intervals selected for sampling should be determined by geology. The intervals are selected by the geologist and marked on

to the core at the time of logging. The boundaries of the intervals should correspond as far as possible to mineralization boundaries that the geologist either observes or postulates. The key rule is this: each sample is selected to answer a question that the geologist has about the core. Only where core to be sampled is relatively uniform should regular samples of predetermined length be taken.

Where core has been lost, it is important that sample intervals do not span the zones where the loss has taken place. To mix a sample of, say, 60% recovery with a sample of 100% recovery is to contaminate good sample data with bad. On the other hand, there is potential information of value to be had by comparing the assays for a sample with good core recovery with that for a similar sample for which the recovery is poor. This can only be done if they are kept separate.

The decision to use half, quarter or whole core as a sample for assay depends upon the need for a sample size adequate to overcome any nugget effects. In general, when sampling gold prospects, the larger the sample size the better. However, sampling whole core should only be undertaken as a last resort, as this destroys the core and prevents any possibility of re-logging.<sup>14</sup> In general half the core, split lengthwise, is taken for assay.

Methods of sampling core depend upon its condition. They are:

1. *Knife-and fork sampling.* This technique is employed where damp clays are encountered. The material is often so soft that it can only be sampled by cutting it lengthways with a knife.
2. *Spoon sampling.* If the material is badly broken, the only realistic method is to use a spoon or trowel to collect a representative section through each chosen interval. Split the broken core into halves lengthways with a broad-bladed spatula and, whilst retaining one half with the spatula, spoon the other half into the sample bag.
3. *Core grinding.* If the core is not considered sufficiently interesting to be sawn in half, but an assay is still wanted as a check, or for a geochemical scan, then the core grinder is a very useful tool (see Fig. 7.20). The grinder takes a shallow shave of rock along the length of the core. This sample is much quicker and cheaper to collect than sawing the core in half with a diamond saw.
4. *Chisel splitting.* Relatively homogeneous crystalline rocks such as igneous rocks or massive metasediment (such as hornfels) can often be split lengthways with a chisel. Special core splitters can be bought for this purpose. The method is quick and can be employed on remote sites where no power is available for a core saw.

---

<sup>14</sup>Between 1995 and 1997, at the Busang gold prospect in Indonesia, some employees of the Canadian junior exploration company Bre-X carried out one of the most massive frauds in mining history. On an almost industrial scale, entire drill core was crushed, salted with extra gold, before being sent for assay. The Bre-X stock price soared from a few cents to over \$285. The lack of retained core to compare with the fraudulent assays meant that the few honest explorationists who made it to the remote jungle site were unable to recognise the deception (see Gould and Willis, 1997; Hutchison, 1998).

**Fig. 7.20** Sampling diamond drill core with a core grinder. The tool is useful for collecting a quick, cheap continuous sample of the core to use as a geochemical scan

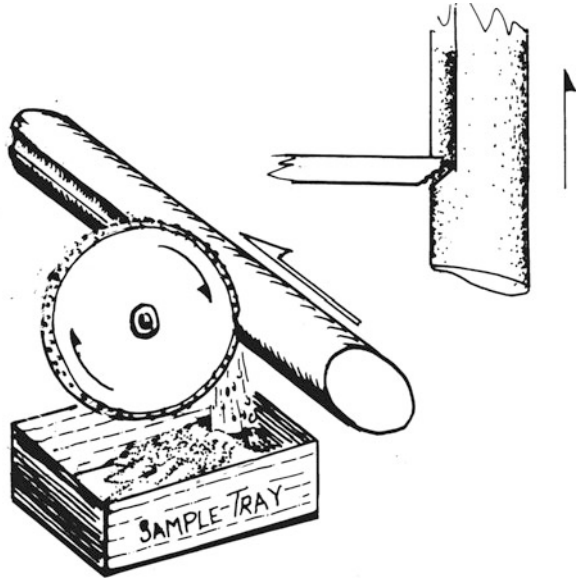

However, any strong pre-existing rock fabric generally ensures that the core will not split as required.

5. *Diamond sawing.* This is the standard and preferred way to sample solid core. The core is sawn lengthways into two halves using a diamond-impregnated saw (Fig. 7.21). The method is slow and relatively expensive but, except where a splitter can be used, is the only way of providing an accurate split of solid core pieces.
6. *Sludge sampling.* The fine rock flour created by the drilling action that spills onto the surface at the collar with the return wash water, is known as sludge. Where drilling recoveries are poor, either because small broken pieces cannot be gripped by the core-lifter, or because the pressured drilling water is removing a clay or silt fraction from permeable rock, the sludge represents some of that lost material. Since poor recoveries are often a feature of zones of mineralization and alteration (especially in epithermal deposits) it is a good idea in these circumstances to gain some idea of what is being lost by sampling the sludge for assay. A channel guides the return drilling water from the collar to the water-return sump. To take a sample of the sludge, dig a small pit on this channel deep enough to hold a 10 l plastic bucket. The silt that collects in the bucket provides the sample for the given drilled interval. The sludge sample can then be stored in an open polyweave bag until dry before being despatched to the laboratory for assay. Note that such an assay provides an indication of grade only. The exact down hole position of the sludge can never be known exactly. In addition, the water action may well have caused a bias in the sample through a sorting by weight of different components of the sludge.

**Fig. 7.21** Sampling core with a diamond impregnated core saw. The core is cut in half along its length: one half is taken for assay, the other half returned to the core tray. The saw used is generally a brick saw modified with a special channel to hold the core piece on the feed tray

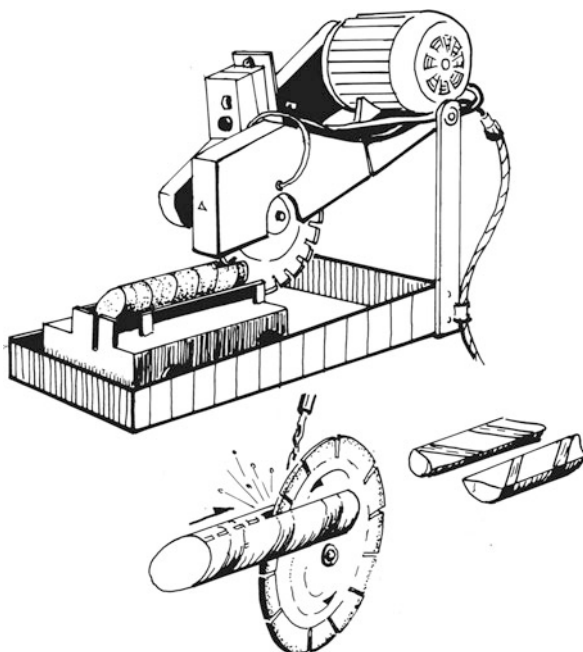

## 7.12 Core Handling

Routine core handling is a role for a suitably trained and experienced field technician, working under the supervision and direction of a geologist. If the technician's job is done properly, the geologist is free to concentrate on observation and recording of the core. The duties of the field technician are set out below.

- Carrying out down-hole orientation surveys.
- Measuring core recovery.
- Measuring RQD<sup>15</sup> (if required).
- Supervising the drillers' core-handling procedure by ensuring core is correctly placed in trays (e.g. not jammed in too tightly or too loosely; ensuring that pieces of core are not rotated in the tray with respect to each other, etc.).
- Ensuring that the drillers' core blocks, which mark the down-hole depths at the end of each drilled interval, are correctly placed and made permanently legible (Fig. 7.22). When the blocks become misplaced (which readily happens when core is transported), the correct position for the block can sometimes be spotted by the parallel grooves that the core-lifter sometimes leaves on the base of each barrel of core.

<sup>15</sup>RQD or Rock Quality Designation is defined as percentage core recovered during drilling, counting only those pieces of intact rock over 100 mm long.

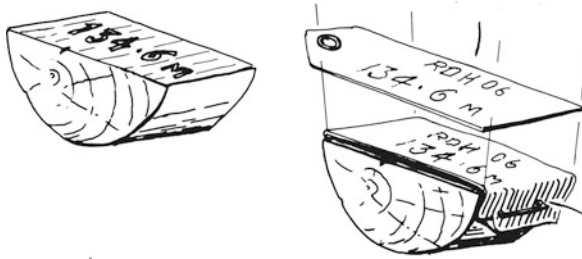

**Fig. 7.22** Permanent marking of drill core –1. Core is expensive and worth preserving, but its usefulness is only as good as the markers which record the start of each run and the down-hole depth. These core blocks should be permanently labelled. In the system shown, hole number and depth are impressed onto aluminium tags which are then stapled to the wooden block

- Measuring hole depth at the beginning and end of each tray.
- Marking hole depth, hole number and tray number on to each tray (Fig. 7.23).
- Marking the core in even one metre intervals as an aid to subsequent logging and sampling. The measurements are taken with a flexible steel tape from the nearest drillers’ core block. The only accurate way to do this is to remove the core from each drilled interval and then reassemble it, piece-by-piece, by carefully fitting the broken ends together in a separate V-section channel. When laid out in this way, and provided there has been no core loss, measuring depth intervals, or marking a line along the core to indicate the proposed cutting line for sawing, is both easy and accurate. A set-up for doing this is illustrated in Fig. B.4.

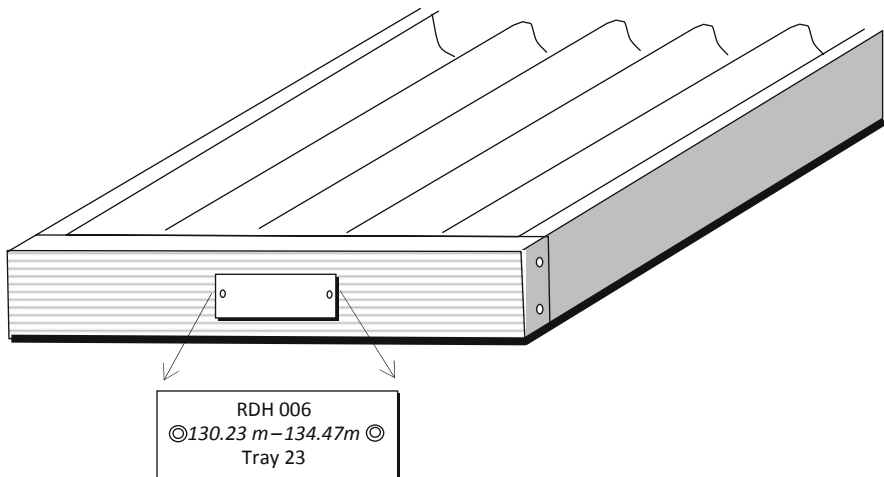

**Fig. 7.23** Permanent marking of drill core –2. The ends of each core tray should be permanently labelled with the hole number, the depth interval stored in the tray and the tray sequence number. In the system illustrated, this information is inscribed or punched onto a heavy aluminium or zinc tag which is riveted to the end of the tray



Reassembly of the core in this manner is essential when dealing with oriented core, or where complex structural relationships need to be resolved. Although time consuming, the technique is strongly recommended, even for non-oriented core.

- Drawing a straight line along the length of the core as a guide mark for subsequent sawing. This position of this line must be determined by the geologist. In non-oriented core the cutting line is positioned so as to make a high angle to any dominant planar structures within the rock. Where the core has been oriented, the cutting line is the Bottom of the Hole (BOH) line – that is, it marks the line of intersection of the vertical or drill section plane with the core (see Sect. B.2 for a description of the BOH line). When drawing the line along the core, the aim as far as possible is to ensure that it is consistently oriented for the entire length of the hole.
- The half core to be retained after sawing and sampling should be identified by the geologist. This half is then marked by placing a small arrow or angled line on one side of the saw line on each core piece. The arrows point down-hole and serve as a vector for each piece of core.
- Cutting or splitting the core and collecting the sample between the intervals nominated by the geologist.
- After cutting, it is important that the same half of the core is always taken as a sample. There are two reasons for this. If the technician sometimes takes one half of the core for assay, and sometimes the other, the retained pieces of half core will no longer fit together, and it may not be possible to replace the core in the core tray. The second, more important, reason is that by preserving a consistent view of the structures seen on the sawn surface of the retained core, geological interpretation is greatly aided.

If the core is oriented, the saw cut along the Bottom of Hole line corresponds to the drill section. One half of the cut core will therefore show structures as they appear on the normal view of that section: this is the half that should be retained after sampling. For example, an E–W section would normally be viewed looking north, so the north half of the core should be retained after sampling (see Fig. 7.24).

- Marking the sample number on to the tray where intervals have been taken for assay. Adhesive sample number tags carrying the same sample numbers as those in the sample books are available and can be used for this purpose.
- Permanently marking and sealing the drill hole collar (Fig. 7.25). This is necessary, not only because open holes can be dangerous, but also because hole collars often need to be re-located, sometimes many years after they were drilled. It may also be necessary to re-enter an old hole in order to deepen it or to carry out a down-hole geophysical survey. For these reasons dirt must be kept from entering the hole.
- Measuring the specific gravity (SG) of the core, where required (Fig. 7.26). SG measurements are necessary in order to calculate the weight (tonnage) of

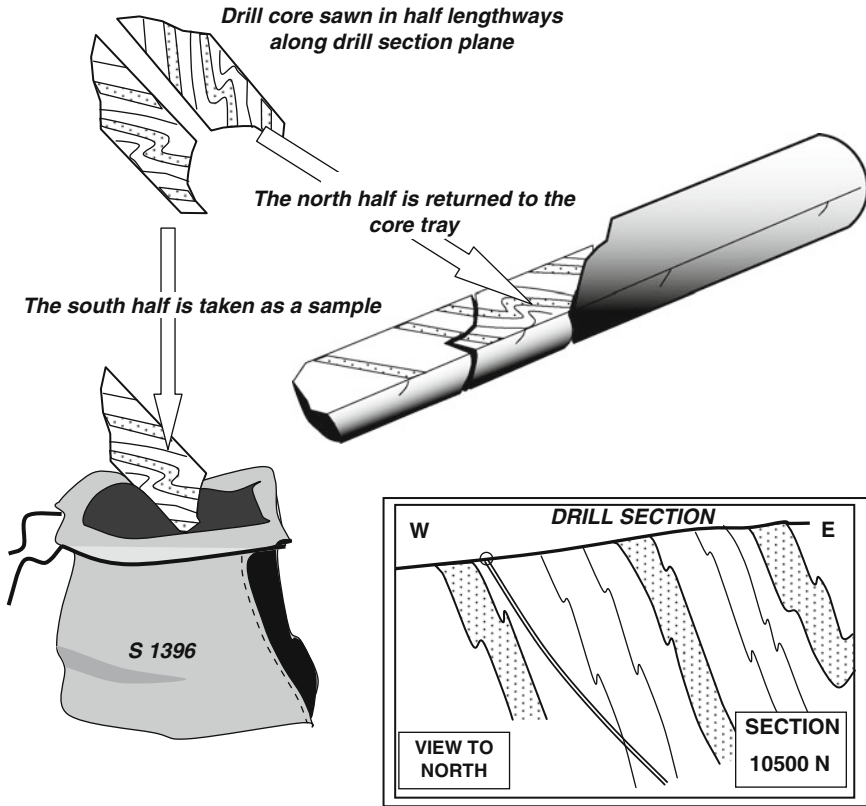

**Fig. 7.24** When taking a half-core sample for assay, the saw cut should follow the original vertical or drill section plane. The sawn surface of the retained core should correspond to the normal viewing direction of the drill section. Illustrated is a hole drilled to the east: sawing produces a north half and a south half: the north half is retained

**Fig. 7.25** A permanently marked and labelled drill hole collar. When finished this way, the collar can be easily relocated and identified, even after many years; stones and dirt are kept out, permitting hole re-entry; and animals cannot injure themselves by stepping into open holes

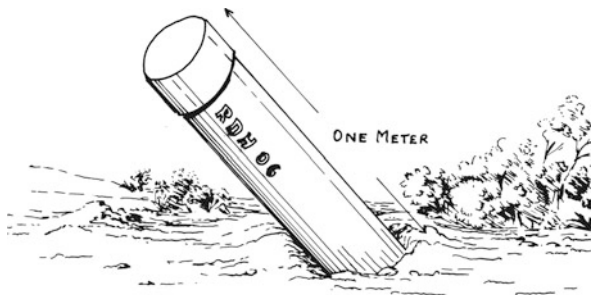

a volume of rock. It is also an important parameter that is used in interpreting the results of gravity surveys. The measurement is easily done by making use of the formula:

$$SG = \frac{\text{Weight in air}}{\text{Weight in air} - \text{Weight in water}}$$

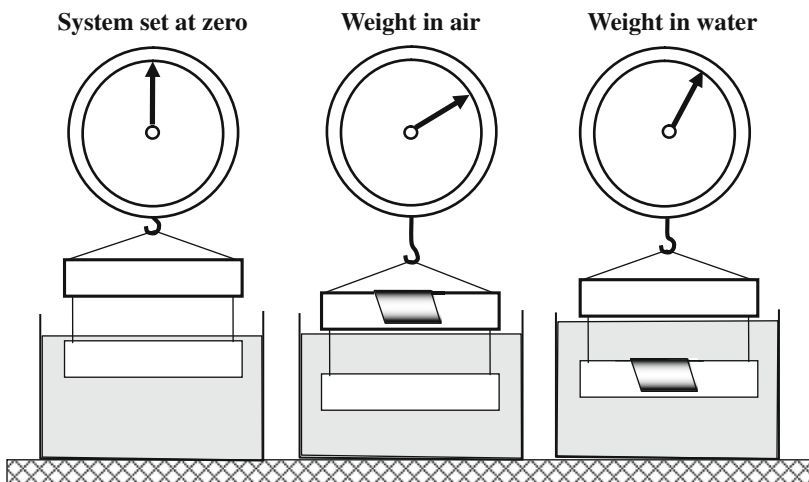

**A FIELD SET UP**

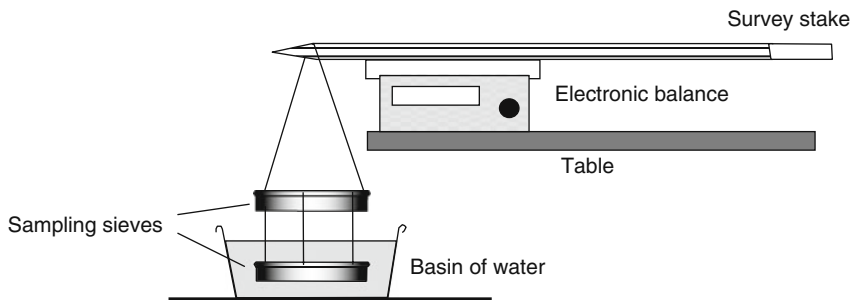

$$\text{SPECIFIC GRAVITY} = \frac{\text{Weight in air}}{\text{Weight in water}}$$

**Fig. 7.26** A simple apparatus for carrying out the weighing procedure for SG measurements. The set up can be used for measuring the SG of small pieces of drill core or any other small rock specimens

## 7.13 Core Photography

Many companies like to make a permanent record of the appearance of their drill core by photographing whole trays of core. Photographs of core in trays generally show little detail, but they can record the broad appearance of the rock, including such features as colour, prominent structures or degree of fracturing. If disaster strikes and core goes missing or is destroyed for any reason, colour photographs of the core will complement the geological logs and ensure that not all is lost. For a quick check of what might be in in historical core, it is much easier to check the photographic record, than to dig out the physical core from its storage racks. At the very least, the process should narrow down the number of trays that have to be extracted in order to physically view the core.

Photographs of core in trays are easy to take, and an acceptable product can be made with a good quality, hand-held digital camera. However, a camera mounted vertically above the core on a special frame produces the best quality images. Photography should be carried out in a place where there is good natural lighting; if this is not possible, artificial lighting will need to be installed around the photographic set-up. In most cases, two trays side by side plus a small chalk board or white board on which the prospect name, hole number and hole depths are marked, will fill the standard frame of a camera image.

The flat surfaces of cut core give much better images than the curved surfaces of whole core. If the core is to be cut, photography should be carried out after cutting. In some cases, wetting the core before photography will bring out its features better, but this is not always the case and each particular core type should be checked to see how it is best prepared. When photographing wet core extra care is needed to make sure that there are no strong light reflections. To bring out all the features of core, it may be necessary to take two series of images, one of wet core, and one of dry.

In addition to making a photographic record of the complete hole as described above, close-up photographs of significant portions of individual core pieces are an excellent way of illustrating detailed features. Such photographs can be keyed in to graphic logs, and are invaluable for making quick comparisons between different holes. A hand-held camera with a close-up lens will usually produce an acceptable image for this purpose, particularly where flat cut surfaces are available for photography.

In many cases, an excellent monochrome or coloured image of the surface of a piece of cut core can be produced on an ordinary photocopying machine. The technique works well where there are good tonal contrasts within the core, and, provided there is a photocopier convenient to the logging area (admittedly, not always the case), this can be an excellent way of quickly recording textural and structural features of a rock. Digital scanners can also make acceptable digital images of small pieces of cut core: these images are invaluable for inclusion in reports.

## References

- Annels AE, Hellewell EG (1988) The orientation of bedding, veins and joints in core; a new method and case history. *Int J Min Geol Eng* 5(3):307–320
- Blenkinsop TG (1994) The fractal distribution of gold deposits. In: Kruhl JH (ed) *Fractals and dynamic systems in geosciences*. Springer, Berlin, 247–258
- Bucher WH (1943) Dip and strike for three not parallel drill holes lacking key beds. *Econ Geol* 38:648–657
- Cloos E (1946) Lineation: A critical review and annotated bibliography. *Geol Soc Am Mem* 18: 1–122
- Cumming JD, Wicklund AP (1985) *Diamond drill handbook*, 3rd edn. J. K. Smit and Sons, Canada, 541p
- Gould D, Willis A (1997) *The Bre-X fraud*. McClelland & Stewart, Toronto
- Hanmer S, Passchier C (1991) Shear sense indicators: A review. *Geological Survey of Canada, Paper* 90-17, 72p
- Hartley JS (1994) *Drilling: Tools and programme management*. A.A. Balkeema, Rotterdam, 150p
- Hobbs B, Means W, Williams P (1976) *An outline of structural geology*. Wiley, New York, NY, 571p
- Huddleston PJ (1972) Fold morphology and some geometrical implications of the theories of fold development. *Tectonophysics* 16:1–46
- Hutchison B (1998) *Fools gold: The making of a modern market fraud*. Alfred A. Knopf, Toronto
- Laing WP (1977) Structural interpretation of drill core from folded and cleaved rocks. *Econ Geol* 72:671–685
- Mandelbrot BB (1983) *The fractal geometry of nature*. W.H. Freeman & Co., New York, NY, 486p
- McLuhan M (1964) *Understanding media: The extensions of man*. McGraw Hill, New York, NY
- McPhie J, Doyle M, Allen R (1993) *Volcanic textures*. Centre for ore deposit and exploration studies, University of Tasmania, 196p
- Mead WJ (1921) Determination of the attitude of concealed bedding formations by diamond drilling. *Econ Geol* 21:37–47
- Pasteur L (1854) Address given on the inauguration of the Faculty of Science, University of Lille. Translation by *The Oxford Dictionary of Quotations*, 3rd edn, 1979
- Peters WC (1987) *Exploration and mining geology*, 2nd edn. Wiley, New York, NY, 685p
- Pumpelly R, Wolff JE, Dale TN (1894) *Geology of the green mountains*. USGS Mem 23:157
- Wilson G (1961) The tectonic significance of small scale structures and their importance to the geologist in the field. *Ann Soc Geol Belg* 84:423–548

# Chapter 8

## Satellite Imagery

### 8.1 General Discussion

This chapter concerns earth observation satellites that are designed to record the electromagnetic radiation reflected from the surface of the earth during daylight hours. It describes satellites that are commercially available at the time of going to press (2010) and detailed on the accompanying Table 8.1. It outlines the capabilities of satellite images and the ways in which they can be used by the explorationist. However, as this is an area where technology changes rapidly, old satellites decline and are taken out of service and new satellite imaging systems are launched almost yearly, the reader would do well to check the current specifications of available satellite imagery. A starting place to do this is at [www.geoimage.com.au](http://www.geoimage.com.au) – this is the website of an image service provider which offers details on all available products and provides an excellent discussion of applications. Other sites that should be checked are those of individual satellite operators such as [digitalglobe.com](http://digitalglobe.com), [geoeye.com](http://geoeye.com), [spotimage.com](http://spotimage.com), [asterweb.jpl.nasa.gov](http://asterweb.jpl.nasa.gov) or [landsat.org](http://landsat.org).

Since they first became available in the late 1970s the data from land observation satellites have provided a powerful range of new tools for the explorationist. Satellite data can be used in three ways:

1. As an accurate georeferenced map – available for any part of the world and through a wide range of resolutions – for use in navigation and location in the field and as a base on which to plot geological observations at all scales.
2. As an overhead view of landscape on which geological features can be directly identified. Geological interpretations can be made from satellite images in exactly the same way as from aerial photographs (see Sect. 2.2).
3. Computer analysis and manipulation of specific reflectance bands can enhance the reflectance signature of minerals (such as certain clays) that might be associated with ore deposits. Used in this manner, satellite reflectance data can provide a powerful and sophisticated remote sensed geophysical survey. This process has been called spectral geology.

Table 8.1 Specifications of commercial land observation satellites in 2010

Satellite	Owner	Launch year	Sensor	Number of bands	Resolution (m)	Best viewing scale 1	Stereo images
LANDSAT 5 SPOT 2, 4	US Government	1984	Multispectral	7	30	100,000	
	French Government	1990	Panchromatic	1	10	30,000	Yes
LANDSAT 7	US Government	1999	Multispectral	3-4	20	60,000	
			Panchromatic	1	15	50,000	
ASTER	JV US & Japanese Govs	1999	Multispectral	6	30	100,000	
			VNIR	3	15	50,000	Yes
			SWIR	6	30	100,000	
IKONOS	GeoEye (US Private Co.)	1999	TIR	5	90	250,000	
			Panchromatic (Nadir)	1	0.82	4,000	Yes
QUICKBIRD	Digital Globe (US Private Co.)	2001	Multispectral	4	3.28	15,000	
			Panchromatic (at Nadir)	1	0.6	2,500	
SPOT 5	French Government	2002	Multispectral	4	2.4	7,500	
			Panchromatic	1	2.5	7,500	Yes
ALOS	Japanese Government	2006	Multispectral	4	10	30,000	
			Panchromatic	1	2.5	7,500	Yes
WORLDVIEW 1	Digital Globe (US Private Co.)	2007	Multispectral	4	10	30,000	
			Panchromatic (at Nadir)	1	0.5	2,500	
GeoEye 1	GeoEye (US Private Co.)	2008	Panchromatic (Nadir)	1	0.41	2,000	
WORLDVIEW 2	Digital Globe (US Private Co.)	2009	Multispectral	4	1.64	5,000	
			Panchromatic (at Nadir)	1	0.46	2,000	
			Multispectral	8	1.8	5,000	

## 8.2 How Earth Observation Satellites Work

Geo-imaging satellites are in polar orbits at heights of 300–600 km. Their passage over the earth is timed so that they are synchronised with the sun, ensuring approximately constant mid-morning sun angles on the earth surface. This time of day enhances relief by providing some (but not too much) shadow, and maximises the chance of cloud or pollution free views.

The satellites do not normally employ photographic cameras to capture their image. Instead, electromagnetic radiation (sunlight) reflected from the earth's surface is focussed onto electronic recording arrays of charged couple devices (CCD) in the onboard imaging instrument (Bedell, 2004). These arrays are capable of resolving the intensity of light from surface areas that can range from 100 to 0.40 m square, depending on the density of the array of CCDs and the closeness of the scanning lines of the satellite instrument. Each CCD measurement is a single data point known as a pixel. Each pixel records the average brightness of the reflected light from the surface of the ground that it represents. Thus the minimum size of a surface feature that can be recorded depends as much on its brightness as upon its size. Very reflective surfaces, such as water (if the sun angle is right) or white water (rocky outcrop on fast-flowing streams) or snow will tend to dominate the reflectance signature, even if the feature itself is small relative to pixel size.

Before arriving at the sensors, the broad wavelength spectrum of incoming radiation passes through a number of filters that exclude all but a few narrow wavelengths, called bands. The bands chosen are different for each satellite, but are generally selected to lie within, or close to, the visible light spectrum, or to highlight particular features of the reflectance of the land surface over which the satellite is passing.<sup>1</sup> The wavelength bands in which reflected electromagnetic radiation intensity is measured and recorded are referred to as multispectral bands. In addition to the multispectral bands, most satellites also record a black and white (total light intensity or panchromatic) image. On any given satellite, the panchromatic band generally provides a higher resolution (smaller pixel size) than the multispectral bands. For each pixel, a series of numbers are recorded for the intensity of radiation in each of the pre-determined wavelength bands.

A scanning system ensures that a reflected light intensity measurement in each wavelength band is made and recorded for each adjacent pixel area across a narrow path on the ground over which the satellite is passing and ensures that the data points are referenced to latitude and longitude and UTM coordinates. When displayed as an image on a monitor or paper print, each data point forms one pixel of the image. Pixel size determines the maximum resolution of the image and thus the most detailed scale at which they can be presented for viewing. Images can of

---

<sup>1</sup>Visible light spans electromagnetic wavelengths from 0.4 to 0.7  $\mu\text{m}$ . Near infra red wavelengths are 0.7–1.5  $\mu\text{m}$ . Short wave infra red (SWIR) spans approximately 1.5–2.5  $\mu\text{m}$ . ( $\mu$  or micrometer is  $10^{-6}$  (one millionth) m).



course be enlarged to any scale required but individual pixels start to become apparent when they are more than 0.2–0.5 mm in size – an effect known as pixellation. Thus an image with 50 m resolution would start to pixellate at scales larger (i.e. more detailed) than 1:100,000. By contrast, a very high resolution (VHR) satellite scene with a 50 cm resolution could be viewed at scales to 1:2,500 before pixellation became apparent.

Satellite orbits are designed so that with successive passes over the earth they are able to provide a complete coverage of the surface. Every few days, the satellite orbit returns to its starting point, and the process is repeated.

### 8.3 Display of Satellite Images

Satellite images can be displayed in a number of different ways. If one of the three primary colours (red, yellow and blue) is allocated to the appropriate corresponding multispectral band, the three bands can then be superimposed and displayed together to give a coloured image which is similar to that of a broad spectrum photographic colour image of the same scene. An image prepared in this way is called a false colour composite. False colour composites are generally the most useful product for general geological image interpretation. The resolution of false colour composite images can be increased by displaying them on monitor or as a paper print along with the higher resolution panchromatic data – a process known as pan-sharpening.

Before display, images are normally computer enhanced to remove slight scale distortions (orthorectification), to enhance colours or contrasts or to enhance edges. Standard grid coordinates, such as latitude/longitude and/or UTM<sup>2</sup> can then be added (georeferencing) to create what is known as a georeferenced ortho image map.

### 8.4 Geological Interpretation

The detailed discussion in Sect 2.2 on methods for the geological interpretation of air photographs apply equally to interpreting satellite images. Some satellites (Spot 2,4 & 5, Ikonos, Alos, Aster) are able to take two images of the same scene from two different angles as it makes a pass over the ground. The resulting image pairs can then be viewed stereoscopically in much the same manner as stereoscopic air photo pairs. Even where the satellite only produces a single image, it is possible to use digital elevation data<sup>3</sup> of the same scene to process the image so as to create a pair of images that, when viewed with a stereoscope, will recreate the 3-dimensional effect.

---

<sup>2</sup>Universal Transverse Mercator – see Sect. 10.5 for a detailed discussion of map coordinates and datums.

<sup>3</sup>Known as a Digital Elevation Model or DEM. At the time of writing (2010) global DEM data can be sourced from NASA's SRTM (Shuttle Radar Topography Mission) altimetry data. SRTM gives a worldwide DEM with values on 90 m centres (30 m for USA) and  $\pm 5$  m accuracy (Rabus et al., 2003).

This process is called pseudo-stereometry. Here is how it is done: the original scene forms the right hand image of the pair. Each pixel of this image is georeferenced so this is the image on which any geological annotations must be made. Using the DEM data an elevation is allocated to each pixel of the image. Computer software then creates a new left hand image by moving each pixel to the west by a distance that is proportional to its elevation. When LH and RH images are viewed together in a stereoscope (Fig. 2.6) a 3-D effect is created. However, for most areas, when using very high resolution (VHS) satellite imagery, available elevation data will be at a much lower resolution than the 2-dimensional image.

Satellite imagery offers several advantages over air photographs. For a start, most satellites provide coverage of the whole surface of the earth. Since the orbiting satellite makes a repeat pass over each point on the ground every few days, it is usually possible to obtain a cloud-free scene, even over tropical areas where clear skies are relatively rare. Low-resolution satellites such as the Landsat series have been doing just this since 1979 and offer a huge library of historical scenes, all of which can be readily searched and cheaply acquired. The same also applies to imaging data from the French long-lived SPOT series of satellites. With the recently launched very high resolution (VHR) satellites – such as Quickbird, Ikonos, Geoeye and Worldview – the volume of digital data they are capable of acquiring is so great that data is generally only collected over limited areas to the order of a client. Acquiring images from these satellites is therefore much more expensive, especially as many satellite passes might be needed before a cloud-free scene is acquired. However, even for these products it is always worth checking to see if archived data is already available. As a general rule, satellite images are much cheaper to buy, per given area and degree of resolution, than contracting a new air photo survey.<sup>4</sup> The ability to provide ortho and georeferenced images is also a considerable advantage since geological interpretations have no scale distortions and can be used directly as a map. Air photographs, of course, can be scanned to digital format, georeferenced and orthorectified in the same manner as satellite images, but this is can be an expensive process.

At the time of writing, satellite images covering the entire earth are available free on the internet from Google Earth ([www.googleearth.com](http://www.googleearth.com)). The Google Earth coverage consists of a mosaic of scenes derived from different satellites, taken at different times and with pixel resolution that ranges from 50 m to a few centimeters.<sup>5</sup> Capital cities, populated areas of first world countries, well known tourist sites and mature mineral exploration terranes tend to have coverage with the highest resolution. On Google Earth, images for any area on the globe can be quickly located, referenced with latitude/longitude coordinates, adjusted for scale, viewed on screen or printed on paper. On screen, the images can be tilted to give a 3-dimensional

---

<sup>4</sup>However, air photos are often available “off the shelf” for a fraction of the cost of flying a new survey.

<sup>5</sup>In areas of high public interest such as large cities or well known scenic attractions, Google Earth makes use of very high resolution air photographs.

topographic effect. The author has used images obtained from Google Earth at scales from 1:5,000 to 1:2,000 as an effective base for geological mapping of open cut gold mines in the Yilgarn Province of Western Australia and epithermal gold prospects in Indonesia.

## 8.5 Analysis of Reflectance Data

Different surface materials (water, humic soil, vegetation, clay alteration etc.) reflect differing intensities of radiation in different wavelength bands. This pattern of reflectance is characteristic for each type of land surface and is known as its reflectance signature. By computer processing the different reflected wavelength bands collected by the satellite, it is possible to produce specialised images that will enhance or suppress the reflectance signals from particular types of surface material. In mineral exploration, this can be particularly valuable in searching for large surface alteration systems where argillic alteration (illite, kaolin, and pyrophyllite) can predominate (Sabbins and Oliver, 2004; Rajesh, 2004). The most distinctive part of the reflectance signature for these minerals occurs in the shortwave infra red (SWIR) part of the spectrum. The SWIR spectral band(s) available on the Landsat 7 Thematic Mapper (TM) and ASTER instruments make their imaging products particularly suitable for this type of analysis. The technique works best in arid or semi-arid climates where extensive bedrock is exposed at surface and there is low vegetation cover. In humid areas the reflectance signature from vegetation (chlorophyll) or clay (cleared fields for agriculture) will usually mask any bedrock response.

## References

- Bedell R (2004) Remote sensing in mineral exploration. Soc Econ Geologists newsletter, 58:8–14.
- Rajesh HM (2004) Application of remote sensing and GIS in mineral resource mapping – An overview. J Mineral Petrol Sci 99:83–103
- Rabus B, Eineder M, Roth A, Bamler R (2003) The shuttle radar topography mission – A new class of digital elevation models acquired by spaceborne radar. ISPRS J Photogramm Remote Sens 57:241–262
- Sabbins FF, Oliver S (2004) Remote sensing for mineral exploration. Ore Geol Rev 14:157–183

# Chapter 9

## Geophysical and Geochemical Methods

### 9.1 General Discussion

In prospective areas where outcrop is poor, or that have been subject to intense mineral search over a long period of time (generally known as “mature” exploration areas), the explorationist increasingly has to make use of geophysical and geochemical methods in order to extend the search into areas of shallow cover inaccessible to more traditional prospecting. Some of these geophysical and geochemical methods also allow for rapid regional appraisal of areas where ground access may be difficult – for example rain-forest terrain or Third World countries with poor infrastructure.

Geophysical and geochemical techniques typically measure objective characteristics that are possessed by all rocks to some degree and result in the collection of large amounts of geographically referenced digital data. Explorationists undertake two different kinds of survey: those that are aimed at defining regional geology and those that aim to directly locate ore. In some cases there is an overlap between these two types.

The first type of survey is a mapping of the areal distribution of a particular rock or soil characteristic – it could be, for example, patterns of electromagnetic reflectance, magnetic susceptibility, rock conductivity or element concentrations/ratios in rocks soils or drainage sediments. These measurements need not have any immediate or direct relevance to the ore body sought. The data is used in conjunction with bedrock or regolith maps produced by the geologist from direct surface observations in order to produce an interpretation of three-dimensional geology. Geological models are then used to predict where ore might be found and so guide subsequent search. This qualitative process of geological interpretation is best carried out as a team effort between the specialist geophysicist or geochemist who understands the nature and limitations of the data set and its presentation, and a geologist who would normally possess the best knowledge of the geology of the area and the potential styles and scales of geological and mineralization processes that might have operated within it. Of course both areas of skill and knowledge might be combined in the one person, but this is rare.

The most important step in the geological interpretation of such surveys (after the technical jobs of ensuring quality of data or purely numerical analyses have

been undertaken) is presentation of the data in a form that facilitates their qualitative interpretation. This step normally turns the digital data into a geologist-friendly analog form. Techniques for producing 2D and 3D analog maps, sections and form surfaces from dense arrays of digital data are described in the next chapter.

The second type of geophysical/geochemical survey is aimed at measuring unusual or atypical features of rocks that directly reflect, and have close spatial relationships to, economic mineralization. Since ore bodies are in most cases small relative to the earth's crust, such surveys have to be based on detailed, close-spaced measurements and are generally expensive. Ore-targeting surveys would normally be undertaken after a prospect, or at least a prospective belt of limited area, has been defined. The critical step in analysing the results of ore-targeting surveys is to select those measurements that can be considered as "anomalous". The selected anomalies are then analysed to determine the probable nature, size, position and shape of the causative body as a prelude to a follow-up detailed exploration programme, usually drilling.

Defining "anomalous" is never easy. If, for example, a level of 20 ppb (parts per billion) gold in a geochemical soil survey is selected as a cut-off number to define anomalism, it would be hard to argue that there is some significant difference between that assay and one of 19 ppb which falls outside the cut-off line. And if 19 is anomalous, then what about 18? And so on. The same problem applies in the analysis of all numerical data sets of this type. Nor can one simply rank numbers according to size – bigger in this case is not necessarily better. A moment's reflection should convince that a small number may reflect a very large source remote from the sample/measuring point, whereas a large number may have come from a relatively small source close to the sample point. And nearness to the sample point is only one of many factors that might enhance or detract from the value of a particular measurement.

Real data sets that provide an adequate sampling of the environment seldom possess sharp natural cut-offs: they typically have a continuous or "fuzzy" distribution. The science of fuzzy logic describes such systems – everything is true to a degree and black and white are merely special cases in a continuous scale of grey. Fuzzy logic is the way human brains work, but is incompatible with the either/or bivalent logic of the computer. For this reason, present-day computers cannot be programmed to select all significant anomalous numbers from a data set: only a human expert can attempt that with any hope of success. The role of computer processing of geochemical and geophysical data is to present it in such a way as facilitates the human judgement process.

This problem of defining anomalous values can often be partly overcome by looking for natural groupings and patterns within the data set and making the reasonable assumption that such groupings reflect the operation of fundamental geological factors, including mineralization processes. Sometimes the natural breaks like this are apparent by simply eyeballing a print-out of the raw data. More subtle cut-offs in the data or breaks in their trends are often definable by graphical means or by statistical analysis. Many commercially available software programs are available which

can highlight these features. These programs are powerful and useful tools that nowadays form an essential part of most analyses of geophysical and geochemical surveys.

In spite of such naturally occurring patterns, if a data set represents an adequate sampling of an area, then any realistic first-stage analysis will almost always divide it into three basic groups.

In the first group – almost invariably the largest one – are those measurements that are definitely not anomalous. These are known as background values and they can be safely ignored, at least as far as the results of that survey are concerned. In the second group – probably a rather small one, if it exists at all – are those measurements that are so different from the background that they cannot be ignored and demand to be explained in some way. Such numbers will generally be confidently labelled as anomalous. The third group is a widely defined category that can be given the distinctly “fuzzy” label of “possibles”. It comprises all the remaining measurements that do not fit into the first two categories. They are those numbers that are slightly above, or at the upper limit of, background values but could be readily explained by non-mineralizing processes. They could, however, equally well be subtle expressions of ore. Since there will probably be insufficient time and money to exhaustively test all of the measurements of this third “possibles” group, a decision on which ones to follow up must be made based on knowledge gained from outside of that particular survey. This may be results from other types of geophysical or geochemical survey or knowledge of the geology and mineralization of the area. The input of an experienced explorationist is required at this point and no software program can make the decision for her.

This is the main reason why no exploration technique should be conducted in isolation. The most powerful exploration programme is normally the one that combines data gathered from several different appropriate geological, geophysical and geochemical surveys. Ultimately, once all processing and presentation steps have been performed, the key to interpreting the results of geophysical and geochemical surveys is an understanding of the geology and ore-forming processes of the area.

Combining different types of map data can be accomplished by overlaying same-scale maps on a light table but this is a clumsy process which is much more easily done on computer using digital data sets and Geographical Information System software (GIS – described more fully in the next chapter).

This chapter presents a brief description of the role that the most commonly used geophysical and geochemical surveys play in mineral exploration. A detailed description of all the geophysical and geochemical techniques available to the explorationist lies well beyond the scope of this book. Moreover, since these techniques tend to be technology-driven, operational details can change rapidly, and any such description would very soon become out of date. For more detail on the theory and field implementation of these techniques, the reader is referred to the references given in Appendix F. However, a general overview of the nature of geophysical and geochemical exploration will serve to illustrate how a balanced, integrated multi-disciplinary approach to mineral exploration can produce successful results.

## 9.2 Magnetic Surveys

The instrument used for magnetic surveys is called a magnetometer. Magnetometers record disturbances in the earth's magnetic field caused by magnetically susceptible rocks. Since all rocks are magnetically susceptible to some degree, a map of magnetic variation at surface (called a Total Magnetic Intensity or TMI map) can provide an image of lithology distribution – an image that to some extent reflects the three-dimensional distribution of rocks and is not affected by thin superficial cover. Magnetic maps are so generally useful to the explorationist that they are easily the most widely used geophysical technique, both as an invaluable aid in regional mapping and for the direct location of those ore bodies that have a distinct magnetic signature.

Regional magnetic maps are usually produced by flying the magnetometer at a low level in regular parallel passes over the ground. Aircraft positioning is nowadays controlled by a DGPS system (Sect. 2.1.7). Data are recorded digitally and presented as a contour or pixel map (Sect. 10.3). Flying at lower levels and decreasing the flightline spacing increases the sensitivity of the survey. Very detailed surveys, comparable in their resolution to ground magnetic surveys, can be carried out by low-flying helicopter.

In ground-magnetic surveying, the sensor head of the magnetometer can be mounted on top of a pole to keep it clear of any near-surface magnetic “noise”. The operator usually takes close-spaced readings along a series of traverses across the survey area. The magnetic readings and station coordinates may be recorded in a notebook but today are more likely to be stored into an electronic memory built into the instrument. Modern instruments can be linked to a DGPS so that map coordinates are automatically recorded against the magnetic reading. Regular repeat readings at a fixed base station provide data to correct for diurnal drift (with modern systems this step is done automatically when time-coordinated data from a fixed base station magnetometer and a mobile magnetometer are downloaded into a field computer at the end of each day).

Processing of aeromagnetics, after editing, correction, and levelling generally consists of a number of common enhancement and presentation techniques carried out on Total Magnetic Intensity data. Computer processing to remove any components of regional magnetic gradient is an important correction for regional surveys but can generally be ignored in detailed local surveys.

If the earth's magnetic field were everywhere normal to the surface, the symmetry of magnetic anomalies would reflect only the symmetry of the causative body. A symmetrical body would produce a symmetrical anomaly located directly over it. However, the magnetic field is only normal to the earth's surface at the magnetic poles, and lies at increasingly lower angles to the surface with distance from the poles, and at the equator is parallel to the surface. This means that magnetic anomalies are all, to some degree, asymmetric. This produces anomalies consisting of a N–S oriented paired magnetic low and high. In the northern hemisphere, the low lies to the north of the high, in the southern hemisphere the opposite holds true. The asymmetry becomes more pronounced the nearer to the equator the survey

is conducted. As a result of this, magnetic surveys conducted in low-latitude areas can be almost meaningless unless an appropriate mathematical correction is applied to the data. The correction process converts anomalies to the appearance that they would have if located at a magnetic pole – the process is hence known as “correction to the pole”.

Other transformations that are normally carried out include calculation of vertical derivatives, and upward continuation. First and second derivatives are used to enhance high frequency signals and help resolve closely spaced trends and the locations of faults and sharp domain margins. Upward continuation, which suppresses the high frequency features, may be of value in recognizing broad domains with different background magnetic intensity.

Image processing consists of assigning sun angles and colours, and combining the magnetic images with other types of data. Sun angles are commonly arrived at by trial and error to enhance particular orientations with particular trends within individual images. Colour allocation is commonly done by assigning limits for each colour on the basis of histogram plots or lookup tables of magnetic intensities of expected rock types in the survey area. In some cases, grey scale images may be more useful than colour, particularly for vertical derivative plots. Combination plots of gravity and magnetic data commonly use the technique of overlaying a grey scale vertical derivative magnetic plot over a coloured image of the gravity. Another commonly used combination is of detailed TMI magnetic contours overlain on a backdrop of the TMI coloured image without sun illumination. Special purpose images might combine magnetic images with geochemical data, or with drill traces and collars high-lighted for significant assays.

A suite of images is typically produced by a bureau or done in-house, and a systematic interpretation completed using a selection of the available images which works best to highlight the known geology or mineralisation. Interpretations may be done with equal success on-screen, or via light table and subsequently captured as a digital file.<sup>1</sup>

Basic interpretation involves defining domains with similar magnetic background and structure, defining linearly extensive discordant features that are likely to be faults, and defining trend lines within the different domains. A quick early pass may be worth doing to identify discrete high intensity magnetic features, both highs and lows, and any swarms of magnetic dykes. It is not uncommon for late plugs and dykes to have remnant magnetism associated with reversal of polarity. At about this stage, more subtle features can then be the focus of investigation, generally using existing geology maps to help define the origin of the magnetic features, and any interesting departures from expected structure and geology.

Most magnetic texture is the result of differences in the abundance of magnetite. Thus a magnetic interpretation will be closely related to geology defined by other

---

<sup>1</sup>But beware the fate of many aeromagnetic images, displayed on the wall to impress visiting analysts and head office management, or reproduced on the front page of company annual reports for investors, but never subjected to a systematic interpretation.



parameters, but can be markedly different in some aspects. Pyrrhotite can be an important magnetic source in some units such as black (carbonaceous) slates and higher grade metamorphic rocks. Serpentinized ultramafic rocks are strongly magnetic due to the presence of fine magnetite, but metamorphosed ultramafic may have only a low magnetic susceptibility. Oxidized granites have strong magnetic intensity, whereas more reduced variants are magnetically quiet. Units of intermediate calc alkaline volcanic origin can be markedly magnetic, and similarly sediments derived from them. Contact intrusive aureoles may be magnetic, particularly around oxidized granites. Regolith units with concentrations of maghemite,<sup>2</sup> particularly channels with pisolitic maghemite gravels, may show a distinctive magnetic response. Alteration associated with hydrothermal fluids provides an enhanced magnetic response in some cases, and reduces it in others. Regional metasomatic enhancement and depletion of magnetic response is characteristic of some areas. Comparison of magnetics and mapped geology often gives good guidelines for projecting geology into covered areas using magnetics. Susceptibility measurements from core and RC chips in mineralized areas are often informative and helpful.

Direct search for magnetic targets related to mineralization is an important exploration technique, particularly in those provinces with iron ore concentrations in Banded Iron Formations, IOCG mineralization styles, strongly oxidized porphyry copper intrusives, magnetite skarns, or pyrrhotite-bearing massive sulphides. In such cases, promising anomalies are generally identified from high quality low level aeromagnetics, and followed up by ground magnetometer traverses and magnetic modelling to define a drill target. Magnetics have been used to define subtle exploration targets such as heavy mineral concentrations in palaeo-strand lines, fault lines through regolith which appear to have controlled favourable opal distribution, and potential iron ore and gold orebodies in palaeo-drainage with maghemitic gravels. Examples of ore bodies that have been found largely as a result of their magnetic response are legion, but perhaps the best recent examples are the Australian IOCG<sup>3</sup> deposits such as Olympic Dam (Reeve et al., 1990), Prominent Hill (Belperio et al., 2007) and Ernest Henry (Ryan, 1998). In another example, the Broken-Hill type, stratiform, sediment-hosted Zn/Pd/Ag deposit of Cannington was also found as the result of drill testing an air magnetic anomaly (caused by associated pyrrhotite) in an area of thick younger cover (Walters et al., 2002).

In areas where exploration is conducted for orebodies below cover units, first pass estimates of the depth to magnetic basement can be made from aeromagnetic data using a number of different techniques. The Naudy<sup>4</sup> technique is a commonly used method.

Combining aeromagnetic interpretation with study of regional gravity and radiometric data (Sects. 9.3 and 9.4) may produce further gains in the interpretation

---

<sup>2</sup>Maghemite is a strongly magnetic iron oxide mineral of the magnetite series. Intermediate in structure between magnetite and hematite, it forms in the regolith through oxidation of magnetite.

<sup>3</sup>Iron Oxide Copper Gold (see Hitzman et al., 1992).

<sup>4</sup>Naudy (1971).

of the underlying rocks. In particular, different granite suites may have distinctive radiometric ratios.

In developed countries, regional, relatively small-scale magnetic maps are usually flown by the government and are available in digital form or standard map-sheet format (as contours or pixels) from government survey agencies. Such maps may not be very detailed but generally do provide a comprehensive regional overview. Large exploration groups will often contract to fly their own aeromagnetic surveys over their tenements at increasingly detailed scales. In some established mining camps, geophysical survey companies have flown large areas of detailed magnetic imagery on a speculative basis, and they offer these data (or sub-sets of them) for purchase by mineral explorers.

### 9.3 Gravity Surveys

Gravity surveys measure lateral changes in the density of subsurface rocks. The instrument used, called a gravimeter, is in effect an extremely sensitive weighing machine. By weighing a standard mass at a series of surface stations, the gravimeter detects minute changes in gravity caused by crustal density differences. Maps of gravity variation can hence be used to map subsurface distribution of rocks and structures, including the anomalous density distributions that might be associated with concealed ore.

To provide usable data, raw gravity measurements need to be corrected. The first correction (for short-term drift in the instrument) is provided by regular reading of a base station in much the same manner as a magnetic survey. The second correction compensates for the broad scale variations in the earth's gravitational field – this correction is only significant in regional surveys. The third correction, much the most important one, corrects for differences in gravity caused by variation in the elevation of the survey station above a datum, usually sea level. To make this correction, stations need to be levelled with great precision – in the case of a very broad regional survey to at least one metre; in the case of a detailed survey aimed at direct ore location, to correspondingly greater accuracies, down to centimetre scale.

The costs involved in the very accurate surveying necessary for altitude correction has, until recently, generally restricted the use of gravity surveys in mineral exploration to low-density, broad-scale, regional coverage. However, differential GPS (DGPS) surveying now allows rapid and relatively cheap levelling of stations and has made detailed gravity surveys comparable in cost to that of ground-magnetic surveys.

A good example of the successful use of a gravity survey as an aid in ore discovery is the location of the high-grade Hishikari epithermal gold deposit of Japan (Izawa et al., 1990). Here, a detailed gravity survey was used to define a buried mineralized structure in an area of known mineralization. The key to the successful use of the technique in this case was the high degree of understanding of the local geology and mineralization, which was used in the design and interpretation of the survey. Gravity surveys (along with regional aeromagnetic data) also played

a significant part in the discovery of the giant deeply buried Olympic Dam (Rutter and Esdale, 1985) and Prominent Hill (Belperio et al., 2007) IOCG deposits of South Australia.

Modelling of the gravity response for the likely range of size, depth, and SG of targets is an important reality check before the technique is used for direct exploration. In some Australian regolith settings, undefined geometries of variable density material in the regolith can produce ambiguous gravity results and spurious anomalies.

## 9.4 Radiometric Surveys

These surveys measure the natural radiation emitted by rocks at surface. The data are collected and presented in a similar way to magnetic data. Radiometric measurements are often carried out from a low-flying aircraft at the same time as air magnetic surveys. Radiometric measurements can also be taken with land-based instruments that can be used at ground stations or lowered down drill holes. The instrument used is called a spectrometer.

The most abundant naturally occurring radioactive element in the crust is the potassium isotope  $^{40}\text{K}$ , largely incorporated into the crystal structure of the rock-forming mineral orthoclase. Of lesser importance as a source of radiation is thorium (found in monazite, an accessory mineral of some granite and pegmatite bodies). The radioactive mineral normally sought by explorers – uranium – is seldom abundant, but at low concentrations can characterize particular rocks such as highly fractionated granites or some black shale sequences. Spectrometers provide selectable channels so that radiation derived from these different sources can be distinguished. Since most natural radiation comes from potassium, maps of total radiation count provide a very effective way of mapping the distribution of alkalic igneous rock and of sediments (such as arkose) derived from these rocks. Monazite weathers from bedrock to form a resistant heavy detrital mineral that often accumulates in watercourses or strand lines. For this reason, these features often stand out on the thorium channel of radiometric maps. Maps presenting ratios of radiometric measurements made in different channels, such as U/Th and K/U can be very useful for discriminating different rock types. Different granite suites may have distinctive radiometric ratios. Radiometric images have no depth penetration and depend on signals from surface materials, so they can be particularly useful in adding value to regolith maps.

## 9.5 Electromagnetic (EM) Surveys

Electromagnetic surveys aim to measure the conductivity of rocks, either by making use of naturally occurring electromagnetic fields in the crust, or by applying an external electromagnetic field (the primary field) and inducing a current to flow in

conductive rocks below. Passing an alternating current through a wire or coil, which is either laid out along the ground or mounted in an aircraft flying overhead, provides the primary field. The current induced in conductive rocks produces a secondary field. Interference effects between the primary and secondary fields provide a means of locating the conductive rock body.

Since many massive metal sulphide ore bodies are significantly conductive, EM techniques are mostly used as direct ore-targeting tools in the search for this type of deposit.

EM systems work best for ore bodies within 0–200 m of the surface. Although, theoretically, larger primary fields and more widely spaced electrodes can give much deeper penetration, the problems of interpreting the results of EM surveys go up exponentially with increasing depth of penetration.

Ground based EM techniques are relatively expensive procedures that are applicable to defining drill targets for specific mineralization styles within established prospects or highly prospective belts. EM systems are available which can be used down drill holes to measure the effects of currents flowing between the hole and the ground surface or between adjacent holes. Airborne systems have been used both for direct ore location and for regional geological mapping purposes.

Problems in interpreting EM surveys arise because many host rocks to mineralization can give a similar geophysical response to the mineralization itself. Water-filled fault lines, graphitic shales and magnetite-rich zones all can give spurious conductivity anomalies. Deep weathering or salty groundwater can make EM surveys either unworkable or at least very difficult to interpret. For this reason, EM surveys have had most success in locating ore in those parts of the world where fresh, unoxidized rocks occur close to the surface. These conditions occur, for example, in the recently glaciated areas of North America, northern Europe and Russia. Notable successes where airborne EM techniques have played a major role in discovery include the massive sulphide deposits of Kidd Creek in Canada (Bleeker and Hester, 1999) and Crandon in the United States (Lambe and Rowe, 1987).

## 9.6 Electrical Surveys

Electrical surveys are all ground based. In their simplest form, they put an electric current directly into the ground and measure, by means of arrays of receivers, the resistance of the rocks through which the current passes. Such surveys are therefore often called resistivity surveys. Current is normally conducted through the ground by the movement of charged ions in pore fluids. Metallic sulphides, which can conduct electric current electronically, can often be detected as zones of anomalously low resistance.

IP is a special type of electrical survey that utilizes the electrochemical (galvanic) effects caused by a current passing through disseminated metal sulphides. The current creates an electro-chemical charge on the boundaries of the sulphide grains where the flow of current changes from ionic to electronic (and vice versa). Such

rocks are said to be chargeable. When the primary current is switched off, the decay of this secondary voltage can be detected, and so provides a measurement of the size and position of the chargeable body. Induced polarization is virtually the only geophysical method that is capable of directly detecting concealed, disseminated sulphides in the ground. After magnetic surveys, the induced polarization (IP) technique is one of the oldest geophysical methods to be used in mineral exploration with the first patent application (by the Frenchman Conrad Schlumberger) being filed in 1912 (Mathews and Zonge, 2003).

In IP surveys, results are normally presented in the form of pseudo-sections. Such “sections” are merely a convenient way of representing the electrical measurements and the contoured shapes of the data on them reflect measurement geometry<sup>5</sup> rather than the geometry of the causative body. Such “sections” cannot be readily equated with a real geological section and need to be interpreted by a specialist geophysicist. However, the use of modern inversion modelling software (see following section) will hopefully make IP pseudo-sections a thing of the past. An example of the successful use of an IP survey is in the discovery of the blind, sediment-hosted, lead/zinc sulphide Gortdrum deposit of Ireland (Hitzman and Large, 1986). The San Nicolas VMS deposit in Mexico was also discovered as a result of an IP survey (Johnson et al., 2000).

Electrical surveys require a generator capable of delivering a high voltage and electrodes placed directly into the ground to transmit the input current. Arrays of receivers laid along the ground measure resistivity or chargeability. The surveys are relatively expensive and labour intensive techniques. They are therefore used as direct ore-targeting tools in established prospects where the presence of disseminated metallic sulphide ore is suspected.

Problems in using electrical surveys can be caused by the short-circuiting effects on the input current that can be caused by salty near-surface groundwater in deeply weathered terrain. Problems in interpretation result from the fact that many zones within rocks, other than bodies of massive or disseminated sulphides, have low electrical resistance or are chargeable.

Electrical methods, as with electromagnetic methods, work best in the upper few hundred metres of the surface in areas where recent uplift and erosion, or glaciation, has produced fresh unweathered rocks relatively close to the surface.

## 9.7 Hybrid Electrical and Magnetic Surveys

These techniques put an electric current (the primary current) directly into the ground via a pair of buried electrodes in much the same manner as for a conventional electrical survey. However, rather than measuring the return voltage with another set of ground electrodes, a magnetometer is employed to measure the magnetic fields

---

<sup>5</sup>Anomalies appear as a characteristic inverted V shape, informally referred to as a “pants leg” anomaly.

that are induced by the primary and secondary currents. This creates much faster and cheaper survey logistics than conventional EM or IP, since the return signal can be measured at a distance. The variations in the induced magnetic fields can be measured and analysed in both space and time. The technique is capable of producing magnetic, resistivity and chargeability data in one survey operation. The techniques are also capable of measuring return signals in areas where conductive surface overburden prevents ground-contact surveys from obtaining meaningful information. Placing the primary current electrodes along the strike of any postulated mineralisation channels the current along the conductive body and so increases the magnetic signal.

With the MMR/MIP technique (Howland Rose, 1984), the magnetic field induced by the primary current is used to measure the Magnetometric Resistivity (MMR) of the ground through which the current has passed. The secondary magnetic field that is induced by galvanic effects on the contacts of chargeable material (i.e. disseminated sulphides) is used to calculate the Magnetic Induced Polarisation (MIP) of the return current path. The results are usually presented as contour or pixel plans which can be interpreted like a geological map to allow deductions as to the shape and size and possible causation of any anomalous bodies.

The Sub Audio<sup>6</sup> Magnetics technique or SAM (Cattach et al., 1993) is an evolution/development of MMR/MIP that makes use of modern sophisticated electronic equipment and computing power to increase the rapidity of field surveying and the definition and resolution of the results. SAM surveys offer very high definition measurements by the use a rapid sampling total field magnetometer (capable of 200 readings per second) that acquires sub-meter measurements while continuously traversing either on foot, by vehicle or even helicopter. The products (with unpronounceable, jaw-cracking acronyms) of a single SAM survey can include: total field high definition magnetics (TFHDM), total field magnetometric resistivity (TFMMR), total field magnetometric induced polarisation (TFMIP) and total field electromagnetics (TFEM). The TFMMR detects variations in the strike direction of the transmitter electrodes so can be a uniquely efficient mapper of the more conductive regions of the subsurface such as paleochannels or zones of deeper weathering. These responses may mask the more subtle signals from conductive bedrock lithologies or metallic ores.

## 9.8 Advances in Instrumentation and Data Modelling

The most significant advances in geophysical exploration for mineral deposits in the last 10 years (since the first edition of this book) have occurred not so much in advances in theory or practice but rather in the development of more sophisticated instrumentation and more powerful data processing.

---

<sup>6</sup>Sub-audio refers to the frequency of the input electrical signal. Though perhaps not the most characteristic aspect of the technique, it does allow for an easily remembered acronym.

New instruments take advantage of the ever increasing compactness, processing speed, memory capacity and cheapness of electronic chips. This allows for increased sophistication in collecting data in the field and for the processing of data at the moment of collection so as to improve such things as signal to noise ratio. Combined with the use of DGPS for survey control, these advances have greatly reduced the cost and time involved in all geophysical surveys, while at the same time increasing their resolution in the detection of anomalous signals in the data. The exponential pace of improvement<sup>7</sup> of microprocessor technology shows no sign of abating.

Traditionally, most geophysical data has been presented for interpretation in the form of contoured or raster plans and sections that can be interpreted in a qualitative way by a geologist or geophysicist in terms of the geology and ore mineralisation that they represent. Over the last 10 years, reflecting the ever increasing capacities of computer processing power, new methods of analysing and presenting geophysical data – whether magnetic, electrical, gravity or seismic – have been introduced that are beginning to revolutionise the interpretation process. These methods are generally referred to as data inversion (McGauchy, 2007; Oldenberg and Pratt, 2007). Inversion techniques make use of complex computer algorithms, and information of the geophysical properties of the rocks and potential mineral deposits of the prospect, to construct mathematically a geological model that agrees, or is at least compatible, with the geophysical observations. The results are presented as a 2-D or 3-D geological model of the body of rocks that were surveyed. The end product can be quite dramatic and can lead to new insights about the geology of the survey area. However, it is important to realise that, as with all computer models, the product of inversion modelling is only as good as the geological choices made in setting up the model parameters, and the accuracy of the geophysical properties that are used in its construction. It is a feature of geophysical inversion models that they are not unique: many different models can be constructed that will reproduce the geophysical pattern that was measured in the field. Choosing between different possible models requires geological knowledge about the area, and the better that knowledge, the more useful and realistic the inversion model. If the model does not make geological sense then it must be discarded and a new one constructed. The person with the appropriate knowledge to audit the inversion model is the project geologist, who needs to work closely with the specialist geophysicist to get the most out of the data inversion modelling process.

It is well worth bearing in mind the cautionary words of Kenneth Zonge about computer created geological models (Mathews and Zonge, 2003):

A note of caution . . . we must be diligent in determining whether results make good geological sense, as the computer can create beautiful, mathematically correct, color sections that do not accurately reflect geology or mineralisation.

---

<sup>7</sup>This development was predicted in 1965 by Gordon E. Moore – a co-founder of Intel – and has come to be known as Moore’s Law. The “Law” states that the numbers of transistors that can be placed on a chip will double every 2 years. So far it has held good, although no exponential trend can ever be projected indefinitely.

## 9.9 Stream Sediment Sampling

Active sediments in the channels of streams and rivers can contain low levels of metals derived from weathering of mineralized rocks within the upstream catchment. This simple fact is the basis for stream sediment sampling – one of the most widely used methods in regional geochemical prospecting. The technique has played a major part in the discovery of many ore bodies, a good example being the discovery of the Panguna porphyry copper/gold deposit on Bougainville Island, Papua New Guinea (Baumer and Fraser, 1975). For the technique to work with maximum effectiveness, ideally the following conditions should be met:

- The area should be one of active erosion with an incised drainage pattern.
- The ideal sample point is on a primary drainage with a relatively small upstream catchment. Even very large anomalies are rapidly diluted in secondary or tertiary streams.
- Only the active sediment on the stream bed should be sampled. Bank material may be locally derived and not representative of the whole catchment.
- In the absence of an orientation survey to define the ideal sample size fraction, the silt fraction of the stream sediment (usually specified as –80 mesh<sup>8</sup>) should be collected. In fast flowing streams a large volume of sediment may have to be sieved in order to collect a sample of suitable weight for assay (at least 50 g but preferably 100 g is needed). Sieving therefore has to be done at site and is best done by washing a grab sample through the mesh of the sieve. The most rugged and best sieves for field use are made of stainless steel with stainless steel mesh (Fig. 9.1g). Sieved samples are usually stored in small Kraft paper envelopes with sealable fold-over tops (Fig. 9.2c, d).
- As much detail as possible about the sample site should be recorded. As a minimum this will include the following information: stream width and flow, nature of the coarse float and nature of any outcrop present. This information will be invaluable when the assay results are later analysed and potential anomalous values selected for follow-up.
- Follow-up of anomalies will usually take the form of stream sediment sampling upstream, along the anomalous drainage, to define the point of entry of the anomalous metal to the stream sediment. Further definition of the source can then be carried out by means of soil sampling on the slopes above the anomalous drainage.

---

<sup>8</sup>This is called the Tyler mesh number and refers to the number of mesh openings per linear inch. The maximum fraction size that will pass through a mesh defined in this way obviously depends on the diameter of the material used for the mesh itself, but for standard laboratory sieves the openings in a –80 mesh sieve are approximately 180  $\mu\text{m}$  or 0.018 mm (Weiss, 1985). For a more detailed treatment of sieve sizes see Field Geologist's Manual published by the Australasian Institute of Mining and Metallurgy – 3rd Edition, 1991.



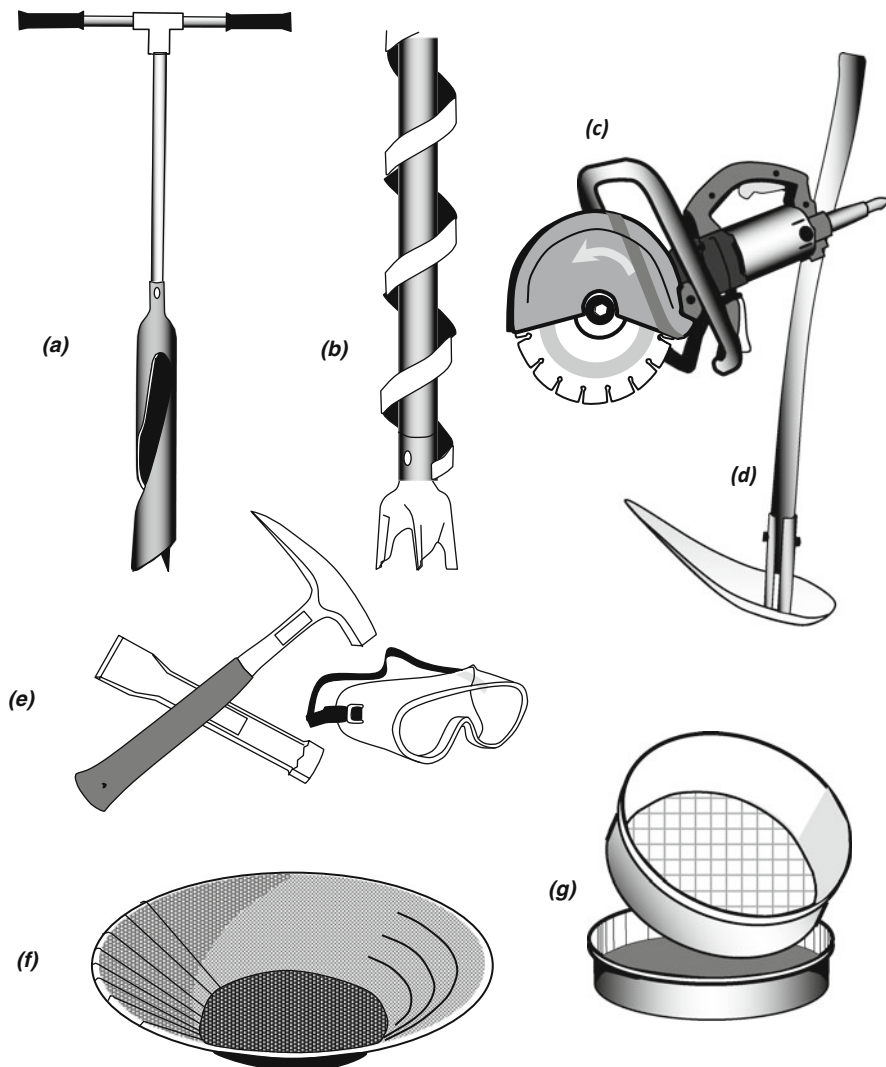

**Fig. 9.1** Some tools for collecting geochemical samples. **(a)** Hand auger. The sample is collected from the barrel on pulling tool from the ground. Extension rods can be added to the shaft. **(b)** A screw or Archimedean auger and bit. Powered by a small petrol or diesel engine, cuttings are brought to surface along the flights. The drill is generally mounted on the back of a light vehicle. **(c)** An electric hand operated rock saw with a diamond blade for cutting channels in rock outcrop. **(d)** A pelican pick – surface soil samples can be collected without stooping and slid easily into a sample bag. **(e)** The standard geologists' rock chip sampling equipment. **(f)** A panning dish for collecting a heavy mineral concentrate. **(g)** Stainless steel sieve and collection pan. For stream sediment sampling a –80 mesh sieve size is commonly used

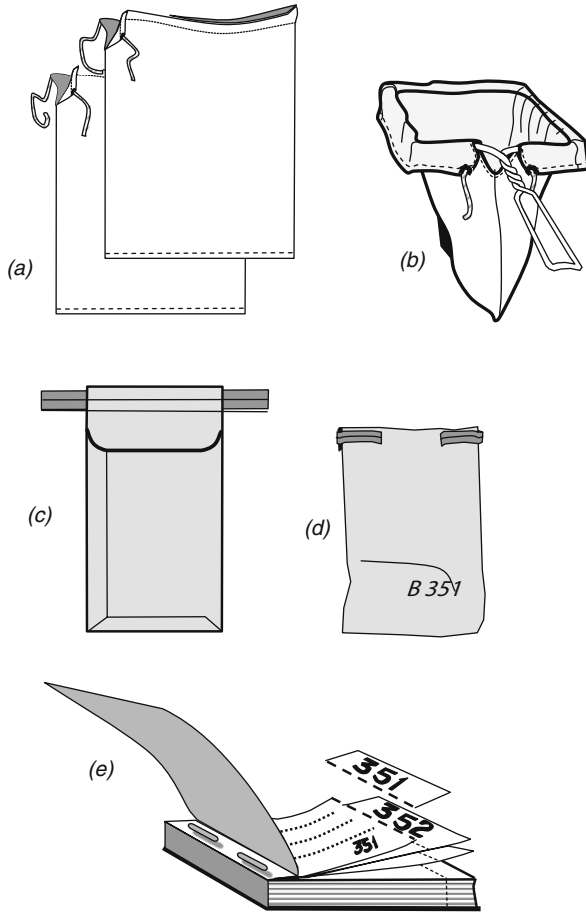

**Fig. 9.2** Consumables used in the collection of geochemical samples. **(a)** Cotton sample bag with draw string top for holding rock chip samples. **(b)** Simple wire frame turns sample bag in a catching device when taking rock chip samples from outcrop. **(c)** and **(d)** Kraft paper envelope (100 × 50 mm) with fold-over sealable top for collection of wet sieved stream sediment samples. **(e)** Sample book with pre-printed sample numbers. Tear-off strip goes with the sample. Sample details (location, sample type, description etc. . .) are recorded on the retained tag

## 9.10 Soil Sampling

This technique relies on the fact that metals derived from the weathering of sub cropping ore often form a wide, near surface dispersion halo around or adjacent to, the deposit. With the ability of chemical analysis to detect very low element abundance, a regularly spaced sampling grid can thus locate the surface “footprint” of the ore body. Significant anomalies may be of the target metal or of elements that are known to be associated with the style of mineralization sought.

As a relatively expensive technique, soil sampling is typically employed in the detailed exploration of prospective mineral belts or established prospects, where it is used to define specific targets for follow-up drill testing. A good recent example of the successful use of the method is the discovery of the Century sediment-hosted zinc deposit in the Mount Isa District of Queensland, Australia (Broadbent and Waltho, 1998).

The sample collected for assay is usually the fine silty or clayey surface material that results from weathering of the underlying bedrock and may contain small fragments of bedrock. A coarse sieve (–10 mesh) may be necessary to remove over-large fragments before taking the sample. The sample is normally taken from just below the organic-rich surface grass-roots layer. A small pick or mattock is used for this job – the “pelican pick” (Fig. 9.1d) – is ideal as it allows the sample to be collected without stooping and slid easily into a sample bag with minimum handling. In some areas (such as rain forest) a hand auger (Fig. 9.1a) may be needed to obtain the sample. Samples are normally stored in calico bags with draw-string tops (Fig. 9.2a).

Not all soils are in situ residual accumulations of weathered bedrock. They may, for example, have been transported for some distance laterally from their source by the action of gravity, wind or rain. The soils may be part of a landscape with a long history of evolution. That history might have involved variable water tables and cycles of chemical enrichment and depletion. To adequately interpret the results of a soil survey it is therefore essential to have an understanding of the regolith<sup>9</sup> of which they are a part. Regoliths can have long and complex evolutionary histories and need to be geologically mapped and interpreted prior to planning a soil geochemistry survey, in order to define those areas suitable for this type of sampling.

In gold exploration, very low concentrations of the metal in soil samples can be determined by employing the Bulk Leach Extractable Gold – or BLEG – assay technique. In this method, a large sample (2–5 kg) of silt sized material is digested for several days in a sodium cyanide solution to extract all contained gold. The solution is then assayed for gold. Because all the gold from a large sample size is extracted, it is possible to obtain an assay for the original sample at the parts per trillion level (ppt).

## 9.11 Heavy Mineral Concentrate (HMC) Sampling

Panning stream sediments to extract any heavy mineral component is an ancient, but still very relevant and effective, geochemical prospecting technique. The heavy mineral concentrate (HMC) can be examined at the collection site to identify and

---

<sup>9</sup>Regolith refers to the surface layer or layers of unconsolidated soil and rock fragments that overly bedrock. It may be derived directly from weathering of underlying rock (residual regolith) or been transported to its present site by surface agents such as wind, water, down-slope creep or human activity.

quantify its mineral content (e.g. number of grains of gold). If required, the concentrate can then be collected into a Kraft paper sample envelope for subsequent assay. Positive results from on-site examination can be immediately followed up with upstream sampling until the source of the anomaly is located.

Panning refers to the process whereby a sample of alluvial or colluvial material is agitated in water in order to separate minerals by their specific gravity. To do this a broad shallow dish or pan with a dark-coloured matte surface is used. Panning dishes range from 30 to 40 cm diameter. The best ones for the purposes of the mineral explorer are 30 cm pans made from dark green plastic as these are light, easily portable and allow both gold grains and the generally darker colours of other heavy minerals to be easily observed. Modern designs (Fig. 9.1f) come with ridges (called riffles) moulded along one side of the dish to help trap the heavy concentrate.

Skill in producing a panned concentrate sample is a very useful one for an explorationist to acquire. Here is a brief description of how it is done:

1. To a large extent, success in panning a heavy mineral concentrate comes in the initial step of collecting the best possible initial sample from the stream bed. The aim is to make use of the natural power of flowing water to separate heavy minerals and concentrate them at particular places in its bed. A 2–10 kg sample (depending on the size of the dish) of gravel and silt is collected from a natural trap in the stream bed – you may have to dig to get this sample and use the point of your hammer to prize out material trapped in cracks and crevices of bedrock. Traps are the upstream side of natural rock bars across the stream bed, material from the bottom of small pot holes in rocky stream beds or, generally, the bottom portion of any gravel layer against the stream bedrock. Exclude from the sample any organic material or any stones more than 2–3 cm across. Include any clay or silt that might come with the sample and bind the gravel/sand together – this will be removed in the subsequent washing process.
2. The sample is agitated with water in the panning dish using alternating side-to-side shaking and swirling motions. In the initial stages you may have to gently agitate the sample with your fingers to wash off clay and fine silt and free up the visible grains of rock and mineral. If done thoroughly the agitation ensures that the heavier mineral grains within the sample settle to the bottom of the dish. As the process proceeds, larger stones, coarse gravel and the less heavy fraction of the wash dirt from the top of the sample is progressively discarded. After a number of cycles of alternate agitation and discarding, the sample is reduced to a small amount of heavy mineral concentrate accompanied by some residual sand in the bottom of the dish. A gentle swirling motion using clean water is then employed to gradually winnow this remaining fraction until only the heavy minerals are left as a V-shaped “tail” running around the base of the pan. The heaviest minerals will lie at the point of the vee. This sample can be examined with a hand lens to see how many colours of gold or other heavy mineral are present.

A written description such as this of how to pan a heavy mineral sample is of limited value compared to actually observing an expert panner at work. Failing

this, some excellent videos of panning techniques can be found on the internet (just search “gold panning” on You-Tube).

Although counting the number of grains of a particular heavy mineral can give an immediate quantitative result from heavy mineral panning, it is more common in mineral exploration for the entire heavy mineral concentrate sample (usually accompanied by a small amount of quartz sand) to be collected for chemical assay.

Heavy mineral sampling is widely employed to locate native elements such as gold grains,<sup>10</sup> platinum, diamonds and heavy resistant mineral grains such as magnetite, zirconium, ilmenite, rutile monazite and cassiterite. Heavy mineral identification is a widely used technique in the search for the indicator minerals of kimberlite pipes.

## 9.12 Rock Chip Sampling

Outcropping bedrock can be sampled directly by breaking off a small piece for assay using a geological hammer or hammer and chisel. Usually 1–3 kg is an adequate sample size. It is important to wear eye protection when collecting such samples, especially when using a chisel (Fig. 9.1e).

Outcropping mineralisation requires a representative sample to be taken across the entire exposed width of the mineralisation. Samples of adjacent unmineralised bedrock should also be taken. There are two ways of doing this.

1. A chip-channel sample consists of a composite of a large number of small, even-sized rock-chips broken from the outcrop with a hammer or hammer and chisel. These are taken along a continuous line (channel) at right angles to the strike of the outcropping unit. For particularly hard rocks, a portable electric jackhammer can be employed to collect the sample (see Sect. 4.4 and Fig. 4.4). Care has to be taken that the composite sample is not biased by collecting too much material from soft, easily broken rock or too little from hard, siliceous difficult-to-break zones. Samples are collected in a cloth sample bag (Fig. 9.2a). A simple wire frame to hold open the mouth of the sample bag will make this task easier (Fig. 9.2b). A minimum of 1 kg of composite sample should be collected for each meter of channel. With a maximum individual sample size of around 3 kg, several samples will be required for wide outcrops.
2. Chip-channel samples are quick to collect but can provide only an approximate, qualitative indication of the mineral content of an outcrop. Although in most

---

<sup>10</sup>A small gold grain – just above the limit of visibility – in the bottom of the dish is known as a “colour”. The number of gold grains from a sample extracted by panning is referred to as the number of colours. Sometimes however (if you are lucky!), larger gold pieces, called nuggets, are recovered.

cases such a sample would be good enough for exploration, in a mine environment a more accurate channel sample is generally required since this may be used in ore reserve calculations. To do this, it is necessary to cut a continuous channel across in the outcrop using a rock saw. Such saws are generally heavy duty electric hand operated tools fitted with a special diamond impregnated rock-cutting blade (see Fig. 9.1c). Two parallel cuts 6–8 cm apart are made across the outcrop at around chest height. The rock between the cuts is then removed using a hammer and chisel. This will produce around 5 kg sample for every meter of channel. An alternative technique is to make two angled saw cuts intersecting in a V. Although this method is quicker, it produces a smaller sample, and operating the rock saw at an angle is more difficult for the operator.

Continuous sawn channel samples are slow to collect especially in hard siliceous rocks. However they offer the best possible representative continuous sample and are comparable with samples obtained from diamond drilling. Rock saw operatives need to wear full safety clothing including eye and hearing protection, dust masks, gloves and heavy duty coveralls. It is important that rock surfaces are thoroughly washed clean of any surface mine dust before any sampling takes place.

### 9.13 Laterite Sampling

In complex weathering profiles that have developed over a long period of time, metals derived from underlying primary mineralization can concentrate in some horizons and be depleted in others. In the weathering process that produces laterite terrains, a layer characterized by iron accumulation forms at or near the surface: this zone is often one of enrichment in metal. In other weathering environments calcium carbonate deposition (calcrete) may preferentially accumulate trace amounts of metal such as gold or uranium. Depending on the geologist's understanding of metal distribution through the laterite profile, geochemical sampling programmes may need to focus on different layers of the weathering profile (Smith, 1987). Where a subsequent cycle of erosion has affected old regolith profiles (a situation that often occurs, for example, in the Archaean Yilgarn Province of Western Australia), the layer of iron enrichment can be stripped away, exposing the underlying leached and metal-depleted zone at surface. Surface sampling of this zone would give no indication of underlying mineralization. The stripped ferruginous gravels (called lag gravels) are resistant rocks and might accumulate down-slope. If they can be recognized and mapped, and their provenance established, ferruginous lag can provide a very useful sampling medium.

The key to devising an effective geochemical sampling programme in laterite terrain is good quality regolith mapping combined with an understanding of the movement and deposition of trace metals through the profile.

## References

- Baumer A, Fraser RB (1975) Panguna porphyry copper deposit, Papua New Guinea. In: CL Knight (ed) *Economic geology of Australia and Papua New Guinea I – Metals*. Australasian Institute of Mining and Metallurgy, Melbourne, 855–866
- Belperio A, Flint R, Freeman H (2007) Prominent Hill: A hematite dominated iron oxide copper–gold system. *Econ Geol* 102:1499–1510
- Bleeker W, Hester B (1999) Discovery of the Kidd Creek massive sulphide orebody: A historical perspective. In: Hannington MD, Barrie CT (eds) *The giant Kidd Creek volcanogenic massive sulfide deposit, vol 10. Economic Geology Monograph, Western Abitibi Province, Canada*
- Broadbent GC, Waltho AE (1998) Century zinc–lead–silver deposit. In: Berkman DA, Mackenzie DH (eds) *Geology of Australia and Papua New Guinean mineral deposits*. Australasian Institute of Mining and Metallurgy, Melbourne, 729–736
- Cattach MK, Stanley GM, Lee SJ, Boyd GW (1993) Sub audio magnetics (SAM) – A high resolution technique for simultaneously mapping electrical and magnetic properties. *Explor Geophys* 24:387–400
- Hitzman MW, Large D (1986) A review and classification of the Irish carbonate-hosted base metal deposits. In: Andrews CJ, Crowe RWA, Finlay S, Pennell WM, Pyne JF (eds) *The Irish minerals industry 1980–1990*. Irish Association for Economic Geology, Dublin, 217–238
- Hitzman MW, Oreskes N, Einaudi MT (1992) Geological characteristics and tectonic setting of Proterozoic iron oxide (Cu–U–Au–REE) deposits. *Precambrian Res* 58:241–287
- Howland Rose AW (1984) The use of RRMIP as a regional mapping tool with examples from the eastern goldfields of Western Australia. In: Doyle HA (ed) *Geophysical exploration for Precambrian gold deposits, vol 10*. University of Western Australia Extension Service, Nedlands, WA, 139–164
- Izawa E, Urashima Y, Ibaraki K, et al. (1990) The Hishikari gold deposit: High grade epithermal veins in quaternary volcanics of southern Kyushu, Japan. *J Geochem Explor* 36:1–56
- Johnson BJ, Montante-Martinez A, Canela-Barboza M, Danielson TJ (2000) Geology of the San Nicolas deposit, Zacatecas, Mexico. In: Sherlock R, Logan MAV (eds) *VMS Deposits of Latin America, vol 2*. Geological Association of Canada, Mineral Deposits Division, Special Publication, St. John's, NL, 71–86
- Lambe RN, Rowe RG (1987) Volcanic history, mineralisation and alteration of the Crandon massive sulphide deposit, Wisconsin. *Econ Geol* 82:1204–1238
- Mathews P, Zonge KL (2003) State of the art in IP and complex resistivity. KEGS anniversary symposium, mining and environmental geophysics – Past, present and future, Toronto, Canada. [www.zonge.com/pdf-Papers/Sof A-IPCR.pdf](http://www.zonge.com/pdf-Papers/Sof A-IPCR.pdf). Accessed 26 Dec 2009
- McGauchy J (2007) Geological models, rock properties and the 3D inversion of geophysical data. In: Milkereit B (ed) *Proceedings of exploration '07: Fifth decennial international conference on mineral exploration*, Toronto, Canada, 473–483
- Moore GE (1965) Cramping more components onto integrated circuits. *Electron Mag* 38(8): 114–117
- Naudy H (1971) Automatic determination of depth on aeromagnetic profile. *Geophysics* 36: 717–722
- Oldenberg DW, Pratt DA (2007) Geophysical inversion for mineral exploration: A decade of progress in theory and practice. In: Milkereit B (ed) *Proceedings of exploration '07: Fifth decennial international conference on mineral exploration*, Toronto, Canada, 61–95
- Reeve JS, Cross KC, Smith RN, Oreskes N (1990) Olympic Dam copper–uranium–silver deposit. In: Hughes FE (ed) *Geology of the mineral deposits of Australia and Papua New Guinea*. Australasian Institute of Mining and Metallurgy, Melbourne, 1009–1035
- Rutter H, Esdale DJ (1985) The geophysics of the Olympic Dam discovery. *Bull Aust Soc Explor Geophys* 16:273–276
- Ryan AJ (1998) Ernest Henry copper gold deposit. In: Berkman DA, Mackenzie DH (eds) *Geology of Australian and Papua New Guinean mineral deposits*. Australasian Institute of Mining and Metallurgy, Melbourne, 759–768

- Smith RE (1987) Using lateritic surfaces to advantage in mineral exploration. Proceedings of exploration '87: Third decennial international conference on geophysical and geochemical exploration for minerals and groundwater. Ontario Geological Survey Special Volume, Toronto
- Walters S, Skrzeczynski B, Whiting T, Bunting F, Arnold G (2002) Discovery and geology of the Cannington Ag–Pb–Zn deposit, Mount Isa Eastern Succession, Australia: Development and application of an exploration model for Broken Hill-type deposits. In: Goldfarb RJ, Neilsen RL (eds) Integrated methods for discovery: Global exploration in the twenty first century, vol 9. Economic Geology Special Publications, London, 95–118
- Weiss NL (ed) (1985) Mineral processing handbook. Society of Mining Engineers of AIME, New York, NY



# Chapter 10

## Geographical Information Systems and Exploration Databases

### 10.1 Definition

Geographically referenced data consist of any type of measurement or observation, whether analog or digital, which have a known distribution across the surface of the ground, and hence can be presented as a map or section. Data of this sort are fundamental to all phases of mineral exploration. Any map is an example of a Geographical Information System – commonly known by its acronym GIS. However, today GIS is more specifically understood to refer to georeferenced data that is stored digitally on, and manipulated by, computer. There are a number of commercially available GIS software programs, and although they are not generally specifically designed for mineral exploration, they are powerful programs which can handle a wide range of GIS applications. Specialist exploration and mining software is available to handle the specific GIS requirements of storage, manipulation and presentation of geological and drill hole data. The brief discussion of the topic in this chapter is designed to show the general capabilities of these programs and is not written to describe any specific software.

### 10.2 The Need for Digital Exploration Databases

Understanding the meaning or usefulness of a particular data set often requires that different types of map data need to be compared. This is a process of integration and is one of the fundamental ways in which data can be converted into knowledge. For example, a map showing surface geological observations may need to be combined with geophysical or geochemical maps from the same area in order to produce a composite map that will facilitate geological interpretation. This interpretation may then need to be overlaid on a land use map to check on access details, or on an existing drill holes map to see what previous exploration had been carried out on the area. Integration of different data sets can be done by overlaying different categories of map on a light table and viewing them as a whole, but this technique is obviously limited to maps which are on the same scale and map projection, and it is in any case never possible to overlay more than three layers by this method.

The limitation can be overcome by preparing photo-enlargements or reductions of existing maps, or even by re-plotting the data at the required scale. However, as the amount of geographical data gets greater, the sheer mechanical process involved in handling large numbers of hard-copy maps, becomes all but impossible. In most of the major mineral exploration provinces of the world, the problem of efficiently utilizing the huge amount of available exploration data is now acute. GIS can offer a solution to this problem. Much of what a GIS does is simply an automation and extension of what was previously done by hand – the power and value of these systems lies in their ability to handle very large data sets and present them in a form that facilitates interpretation by the explorationist.

Different types of data for the same area are stored by GIS on separate “layers” with reference coordinates providing the link between information on the different layers. Once in electronically-stored digital format, the data sets can be enhanced, searched, compared, combined, presented at any scale, displayed on a monitor as a 2-D or 3-D image or printed, as required, as hard copy maps and sections.

At one time, exploration offices had a few map cabinets, a light table, a filing cabinet for assay reports and the like, and a small bookshelf with some dusty copies of the *Economic Geology* journal and a few Geological Survey reports. Now such offices are more likely to have computers on every desk, linked to head office and a big database on a server. The database has taken on a life of its own, and can be a source of competitive advantage if managed well or the stuff of nightmares if it is in a state of neglect. Every geologist needs to be involved in keeping the data in good order. There needs to be well understood and respected protocols for adding and correcting data, and the handling of data between head office and project offices.

Significant skills are needed to successfully interrogate and manipulate all the relevant data in some of the larger exploration databases. These are in addition to the still-relevant skills of the explorationist in mapping, logging, making interpretations of structure, geophysics and geochemistry, and making inspired intuitive guesses as to where to explore next.

One major part of the exploration database is the collection of geographically referenced files that can be accessed via GIS software. This might include: geology maps at various scales; images of aeromagnetics, gravity, radiometrics, and any other geophysical surveys; maps with various displays of geochemical data; topographic and cultural maps; tenement maps; satellite images; scanned aerial photographs; digital elevation plots; mineral occurrence maps, and interpretation maps. Every map file needs to be cross-referenced to a file of an accompanying report, however brief, so that each map file can be given a date of origin and a context.

Historical data from earlier work are often available from government or specialist data firms. Care needs to be taken with grid coordinates; map datums, projections, and location accuracy (see Sect. 10.5). Field checking of prospect and drill collar locations to validate legacy data needs to be carried out whenever and wherever possible.

A drill hole database may be run in parallel to the GIS database, or integrated with it, depending on the available software and database design. This will include

data on collar and down hole surveys, assays (including re-assays and check assays), geological and geotechnical logs, magnetic susceptibilities, driller's logs, structural measurements, SG measurements, and the like.

At the heart of the drill database are the 3-dimensional plots produced by specialist drill hole software. These may be compatible with GIS software, insofar as drill collars and drill hole traces with geology, assays and other information can be overlain on surface or level plans. In some cases, sections can be plotted by GIS software, or GIS plan and level data can be plotted using mine software. The specialist software for drill hole data can also produce 3-dimensional polygons and polyhedra representing faults and geological units; this cannot be done by most GIS software. Special sections can also be plotted that cut structures, units, and interpreted polyhedra at angles that are not orthogonal to the surface. And most importantly, the data can be viewed and rotated in three dimensions, allowing exploration of relationships that is not possible in the GIS software.

All specialist drill hole packages can plot geology from encoded data fields. However, geologists commonly collect much more data, especially from drill core, than can be readily plotted and used in the drill hole software. The key to success in plotting the geology is to select those things that are most significant, and plot only those. In the early stages of projects where very detailed geological logging is normally carried out (see Sect. 7.8.2) only carefully selected summary data would normally be entered to the computer data base. Analytical spread sheet logging (Sect. 7.8.3) – the logging style recommended for drill holes in advanced exploration and mining projects – is pre-designed so that it can be entered directly in to the digital data base.

The use of encoded data fields raises the problem of geological codes. If only one geologist was assigned to a project for its entire life, he could invent appropriate codes, stick to them, and few problems would arise. Otherwise, there has to be disciplined use of geological codes so that the geological observations of different geologists working on different parts of a project, at different times, can be consistently recorded in the data base. In general, the more universal and widely applicable a geological code system is, the better, as this will allow it to be used on different projects, and at different stages of the same project. However, this can create its own problems, because the more complicated and universal the code system, the more degrees of latitude are available for the explorationist in his descriptions. Without some enforced consistency, this can completely undermine any capability of the system to combine the work of different geologists. The correct balance between project-tailored and universal data codes is one that each exploration group has to determine according to its needs and abilities.

Up to this point, the discussion has been about exploration data bases. However, much exploration is done in the vicinity of working mines or in mining camps where mines have operated. In these cases, the mine database will not only have the drill hole database described above, but also pit pickups, level surveys, stopes, ore-shells and ore blocks, grade control data, and engineering works and proposals. The 3 dimensional software used for feasibility and mining must have capability for

kriging<sup>1</sup> and other geostatistical routines, wire framing, and capabilities for planning, scheduling, and running the mine by the mining engineers and surveyors. In most cases, the software required is changed with each stage of the progress of the project from exploration to feasibility to mining. At each stage digital data is generated which will have compatibility problems when it has to be used for the next stage. It is much easier to go forwards from relatively simple data at the exploration stage to the data generated by mines, but sometimes the reverse has to be done as well.

It is worth bearing in mind that even if an orebody has not been discovered during exploration of a mineralized area, the project will probably be looked at again, sometimes by the same geologists who worked on it earlier. Although in an ideal world this should not be so, today this all too often means that if a drill log, a report, a map or a section isn't in the digital database it simply doesn't exist. Many a truckload of paper files and plans has been delivered to the nearest dump by contractors paid to restore the site office to pristine condition. The point is obvious, good digital databases are valuable, and care of them will save money.

### 10.3 GIS Storage of Map Data

Geographically referenced data are traditionally stored as paper or film maps, or on printed paper files (hard copy). However, many government geological and geodetic mapping agencies now sell their map products directly in digital format on compact disc or in files that can be downloaded from the Internet. Digital map data, such as GPS data, remote sensing imagery, most geophysical and geochemical measurements, or isolated point data such as hole collar locations, are already in a natural form for electronic storage in computer.

All these data types, whether they represent an original line, area, number, rock type descriptor, symbol or whatever, are recorded in the electronic data base against geographical or Cartesian reference coordinates (see Sects. 10.5.1 and 10.5.2 for a description of coordinate systems).

Analog data, such as aerial photographs or printed geological maps, can be converted into digital format for electronic storage and processing in three ways. The processes all involve a sampling of the original analog data and their accuracy depends upon the closeness of the sampling points or sampling areas.

#### 10.3.1 Digitised Line Format

The lines which define the boundaries of the different sub-areas of the map (or photograph) can be defined by the coordinates of a series of closely spaced points along them. This is normally done manually by running an electronic cursor (called

---

<sup>1</sup>Kriging is a mathematical geostatistical technique that interpolates the value of a random variable at an unobserved point from observations of its value at adjacent observed locations.

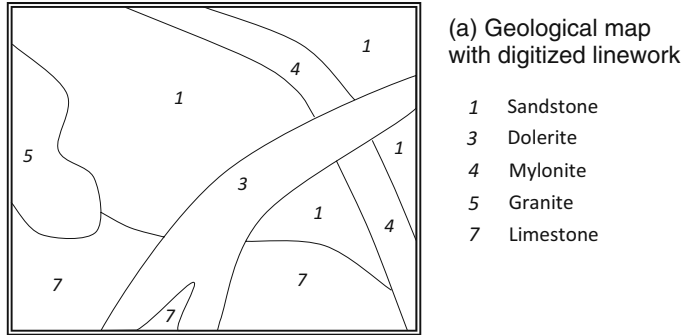

(b) Geological map in raster or pixel format.

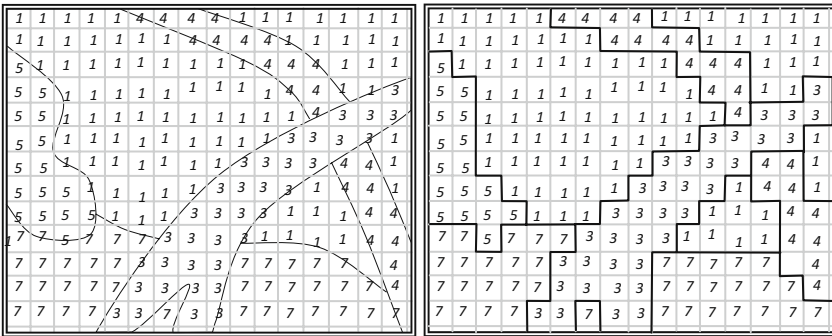

(c) Geological map in polygon or vector format.

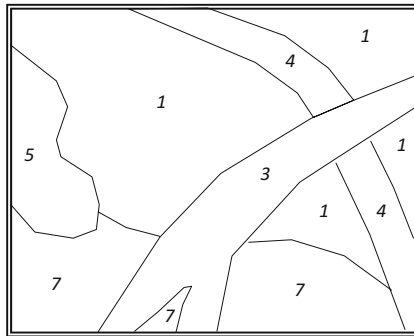

**Fig. 10.1** Map (a) shows the lines marking the boundaries between the units of a geological map. The lines have been digitized so the map can be electronically stored and reproduced without losing definition. Digitizing lines provides no information about the nature (attributes) of the areas between the lines. In (b) the same geological map has been converted to raster format by overlaying a regular square grid. Each cell or pixel of the grid is characterized by its dominant attribute. In (c) each sub-area of the map is represented by a polygon. Each polygon is defined by the straight-line vectors between points established along the boundaries of the sub-areas. Vector coordinates lie on the 2-dimensional map plane; a third dimension can then be used to record the attribute of the sub-area. Raster maps and vector maps convey information about areas

a digitizer) along the lines of a hard-copy map, and using a software program to convert the position of the cursor into a sequence of coordinates. The digitized points along a curved line are normally sufficiently close to enable a line, undistinguishable from the original curved line, to be drawn through the points. Automatic scanners are also available which can identify and digitize lines on a map (Fig. 10.1a).

### ***10.3.2 Polygon or Vector Format***

A series of points can be manually defined, using a cursor, around the boundary of each area of the map. The software then calculates the position and direction of the straight lines between these points, thus defining a polygon. The information is recorded as vectors lying in the horizontal map plane. A vector in the third dimension can then be used to represent the attribute (e.g. sandstone, or colour red, or number 346) that is represented by that polygon. The polygon system thus characterizes and defines areas, rather than lines (Fig. 10.1c).

### ***10.3.3 Raster Format***

A fine grid (usually, but not always rectangular) is laid over the map, and those squares or cells of the grid which have the same attribute are identified (Fig. 10.1b). The process can be done manually, but usually a scanning device is used. Where a grid cell covers areas with more than one attribute, the characteristic of the largest area within the cell is recorded as the attribute for that cell. Scanned maps and photographs that are stored and presented on the grid format are known as raster maps. Like the polygon system, raster map information records the attributes of areas of the map. Analog map data (printed maps, aerial photographs etc...) that are scanned to digital format are raster maps.

## **10.4 Validation**

Data that have been collected digitally and entered directly into the computer, or read into the computer by some sort of scanning process, are likely to be relatively error free. However, where manual entry of numbers has been involved in producing computerized databases, errors can be expected. This problem applies particularly to databases that contain a large amount of historical information that has been typed in from old hard-copy files. Errors such as these in large databases can be a major problem and are very hard to spot, particularly where the data have been computer-processed in some way before use. Validation of digital databases is therefore a vital part of any data entry process. There is really no easy way of doing this (at least the author does not know of any). It is best done by comparing a hard-copy print-out of the data, visually scanning for inconsistencies, and carefully, point by point, line

by line and area by area, comparing the print-out with the original sources. A useful technique is to display the data as a graph, map or section and to look for obvious outliers. As an example, on a drill section, holes shown collared well above or below ground level probably reflect a data entry error or an error in the original collection or recording of the numbers.

Much historical exploration or mining data is based on locally established grid systems which may not be tied in to universal grid coordinates such as latitude/longitude or UTM (Sect. 10.5). In this case field work will have to be undertaken to locate old grid pegs or drill hole collars that can be surveyed using a DGPS. Collar coordinates are often quoted incorrectly in old reports, and field surveys may also be necessary to correct these mistakes.

Data validation can take almost as long as the original data entry, but it is essential that it be done.

## 10.5 Georeferencing

### *10.5.1 Geographical Coordinates*

A geographical coordinate system defines each point on the surface of the globe with two numbers, each based on an angle measured from the centre of the earth. The familiar geographic coordinates are latitude and longitude. Latitude measures degrees ( $0-90^\circ$ ) north or south of the equator. Each degree of latitude is approximately 111 km and is much the same anywhere on the globe. Longitude measures degrees ( $0-180^\circ$ ) east and west of an arbitrarily defined (but universally accepted) “prime meridian” ( $0^\circ$ ) running N–S through Greenwich in the United Kingdom. Unlike latitude, the length of a degree of longitude varies according to position. At the equator a longitude degree is the same as a latitude degree (approximately 111 km) but its length progressively decreases both north and south to become zero at the poles.

Geographical coordinates are the most fundamental system of coordinates available, but they have many drawbacks. Measuring the distance between two points is difficult if they are defined by lat/long coordinates and have a large N–S separation (it involves spherical trigonometry). Also, since a degree is normally subdivided into 60 minutes ( $60'$ ), and a minute into 60 seconds ( $60''$ ), they are rather inconvenient to units to use when measuring or plotting a position on a map.

### *10.5.2 Cartesian Coordinates*

Cartesian coordinates are based on linear distance from a defined point of origin and generally provide a more user friendly system of coordinates than latitude and longitude. Distances between points can be determined by simple trigonometry. The most widely used Cartesian coordinate system in use today is called Universal Transverse

Mercator (UTM) and was developed by the US Army in the 1940s. Nowadays UTM coordinates<sup>2</sup> appear on almost all published medium and large scale topographic maps alongside the more traditional latitude and longitude system. In the UTM system, the earth between latitudes 80°S and 84°N is divided into 60 numbered zones each of which is 6° longitude in width. Zone 1 is centred on longitude 177°W (i.e. it extends from 174 to 180°W): successive zone numbers then increase in an easterly direction.<sup>3</sup>

In each zone, the east coordinate (called the easting) of a point is based on its distance in meters from the central meridian (longitude) of the zone. To avoid negative numbers, the central meridian is given a “false easting” of 500,000 m – thus anything west of the central meridian will have an easting of less than 500,000 m. At the equator, each Zone is 666 km wide: in each Zone, UTM eastings thus range from 167,000 to 833,000 m – the range of eastings decreases progressively towards the poles.

The north coordinate (or northing) of a point is based on its distance in meters from the equator. In the northern hemisphere the equator is given an initial northing of 0 m and northings increase from there to the north. At 84°N latitude (the maximum extent of UTM Zones), the northing is 9,328,000 m. In the southern hemisphere, to avoid negative values, the equator is given a “false northing” value of 10,000,000 m. Northings then decrease to the south. The equator is thus either 0 m N or 10,000,000 N, depending on your point of view.

Where the boundary between two UTM zones falls on a particular map, the coordinates for both zones are normally shown for 40 km either side of the boundary. This enables distances between points located on either side of the boundary to be measured using the coordinates of only one zone.

### ***10.5.3 Map Datums***

A map is a two-dimensional representation of a portion of the 3-dimensional curved surface of the earth. The means by which 3-dimensional objects are shown on the map surface is known as the map projection. All map projections create some degree of distortion. UTM coordinates are plotted on a map using the transverse mercator<sup>4</sup> projection. This projection is chosen because it creates minimal distortion over

---

<sup>2</sup>Although it may not be called UTM on your map. In Australia, for example, the UTM coordinate system is referred to as Map Grid of Australia '94 (MGA94).

<sup>3</sup>Zones 10–19 cover the contiguous states of mainland USA; zones 17–24 cover South America, zones 28–38 Africa, zones 46–50 East Asia and zones 50–46 cover Australia.

<sup>4</sup>Named after the sixteenth century Flemish cartographer, Gerardus Mercator. The Mercator projection has the feature of preserving angular relationships (and hence approximate shape) but distorts distance and area. A bearing measured on a Mercator projection will correspond to a bearing on the ground. Most medium and large scale maps employ the Mercator projection. However, smaller scale maps (the kind you might find in a regional atlas) may use a variety of different map projections.



regions with small E–W width and large N–S extent. A separate transverse Mercator projection is used for each UTM Zone.<sup>5</sup>

The shape of the earth varies from a perfect sphere by a small amount. It is slightly asymmetrical, flattened from north to south and bulges a bit in the southern hemisphere. This shape is known as the geoid. Map projections are dependent upon the mathematical geoid model used to describe the shape of the globe. Today the most commonly used geoid model is known as the World Geodetic System 84 or simply WGS84. This is the standard adopted for plotting UTM coordinates, and it is the standard used for satellite based GPS applications.

For any map, the projection plus the geoid model used in its construction are known as the map datum. Information on the datum will normally be found printed on the margins of any published topographic map. Although WGS84 and UTM are widely used standards, historical maps, and other maps that may be available from different parts of the world may show different coordinate systems and map datums. Software programs are available which can convert coordinates from one map datum to another. This software is a standard component of GPS instruments and is usually also available in commercial GIS software packages.

### ***10.5.4 Map Registering***

If GIS data from different sources are to be combined and manipulated by computer, they must be converted to the same coordinate system and map datum. This process is known as registering. Many geology, geophysical or geochemical maps or remote sensed images carry no coordinates or show only locally defined coordinates. To register these maps a series of control points have to be selected on each map or image and the UTM coordinates (or latitude and longitude) for these points entered into the software. Usually at least four points (one near each corner and one near the centre) are required for each map. The GIS software will then automatically georeference each point or raster cell in the map/image. For this process, points are selected that can be easily matched with known UTM coordinates. Sometimes a special ground survey will be necessary to obtain this information.

## **10.6 Manipulation of GIS Data**

Once in digital format and georeferenced, GIS software allows map data to be manipulated in a number of ways. Searches can be done for different attributes. Selected ranges of numbers can be highlighted. The position, size and attitude of different map areas can be compared, either within the same layer or between different layers. By selecting the appropriate presentation format, different layers of data

---

<sup>5</sup>The nomenclature is a little confusing here. Transverse Mercator (TM) is a map projection. Universal Transverse Mercator (UTM) is a system of cartesian coordinates.

can be combined into the one image. The types of data which are often combined in this way are regional geophysical or geochemical surveys with geology; geology or geophysics data with satellite or radar imagery; geology mapping with surface spot heights (the latter in the form of a digital elevation model or DEM). The purpose of such composite images is to facilitate visual recognition of key correlations between the data sets.

Finally, the GIS program will be used to select an appropriate image for printing a hard-copy map at an appropriate scale and within selected boundaries.

## 10.7 Presentation of GIS Data

The computer can do a lot of essential processing of digital data but, once this is done, qualitative interpretation requires conversion of the data to map format. Map presentation, whether on a monitor or paper print, makes use of the power of the linked eye and brain system to distinguish meaningful patterns and spatial relationships in complex data sets.

Geochemical and geophysical data are normally collected along closely spaced grids or scan lines and are traditionally shown as contour maps (Fig. 10.2b). Contouring is still a widely used and valuable technique but it can only present a relatively small sample of the data (the numbers selected for the contour intervals). Much of the information contained in a data set is not used by a contouring program and, as a result, subtle features can be smoothed over and lost. This can be overcome by using more closely-spaced contour lines, but in areas of strong gradients this can lead to lines piling up on top each other in an inky mess.

Where the data are collected along regular scan lines (e.g. magnetometer readings, or soil sampling lines), measurements along each of these lines can be presented as a two-dimensional graph or section. By correctly positioning (stacking) such sections in parallel rows across a map base, all of the measured survey data can be shown and some impression gained of the spatial relationships between successive scan lines (Fig. 10.2a).

Because of their ability to present the full range of the measured attribute, stacked sections are widely used by geophysicists and geochemists for quantitative interpretation of regularly scanned data. However, the product is still only a set of two dimensional slices and stacking such sections in parallel rows offers only minimal help to the eye in discerning the correlations between sections, especially if they are widely spaced. On the other hand, if the stacked sections are closely spaced they will overlap and create a confusing jumble of lines (this has been avoided in Fig. 10.2a by showing only one section in five).

A powerful technique, now widely used, overcomes the problem of three-dimensional map presentation by visually representing the value of the measured attribute as a point on an infinitely variable<sup>6</sup> colour range or grey tone. The tone

---

<sup>6</sup>In fact, there is a limit to the range of tonal and colour variation that the human eye can distinguish, but this is still great enough to represent very fine detail.

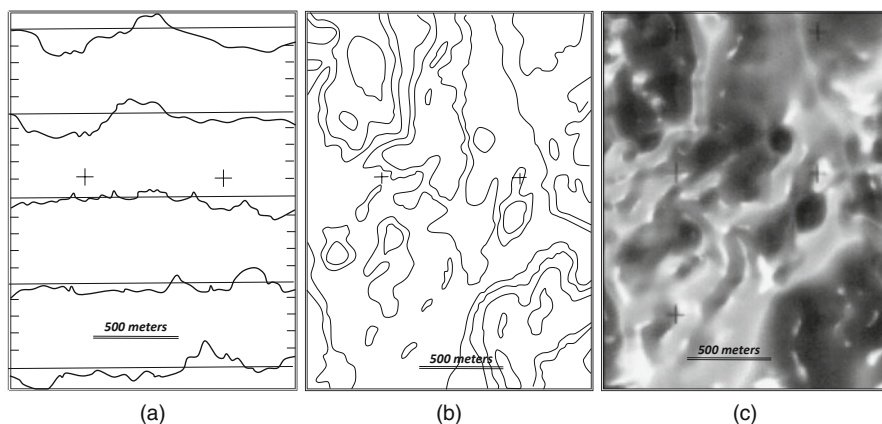

**Fig. 10.2** Three different ways of representing two dimensional data on a three-dimensional plane: an example from an air magnetic survey with 100 m spaced, E–W flight lines. In (a) the magnetic readings along each flight line are shown as stacked sections arranged across the map (to simplify, only a few sections are shown). This format preserves all the original magnetic data, but it can be hard for the eye to make spatial correlations. In (b) a computer program has distributed the linear flight line data across the two-dimensional map, and the results shown as contours. This facilitates qualitative interpretation, but some of the original magnetic detail has been lost. More contour intervals can recover some, but not all, of this detail. In (c) software has again distributed the linear data over the 2D map area. Presentation is in raster format with magnetic intensity represented by allocating a range of grey tones to each pixel (the original of this map is in a range of colours from blue (low values) to red (high values)). Some information is still lost, but this type of presentation is an excellent compromise between preserving the original range of measurement and presentation in a form that facilitates geological interpretation. Once in Raster format maps can be manipulated mathematically to enhance particular features of the data set

or colour is then printed on the map to characterize the area considered to have influenced that measurement (Fig. 10.2c). Each area of a single tone is known as a pixel (from picture element). Provided the pixels are sufficiently small (this depends on the closeness in space of the original measurements and the scale at which the map is presented), such computer-generated images have the appearance of a photographic print and are relatively easy for a geologist to interpret. Original measurements collected along regular sampling lines such as the data from most geochemical and geophysical surveys, can be presented in analog map format by conversion to a pixel map. Pixel maps are similar to raster maps – the only difference is in the way they are prepared. Some remote sensed data such as satellite reflectance imagery is already collected in a pixel based raster format.

The key step in the process of producing a contour or pixel map is the conversion of a series of one-dimensional data streams – i.e. the numbers collected along the traverse or flight lines of the survey – into a two-dimensional data array. Computer software does this by calculating a value for all those sub-areas or pixels of the map that were not measured in the survey. The most common way of doing this is by triangulation. The software constructs lines between all adjacent known data points to form a network of adjacent triangles across the area. This is done so that no

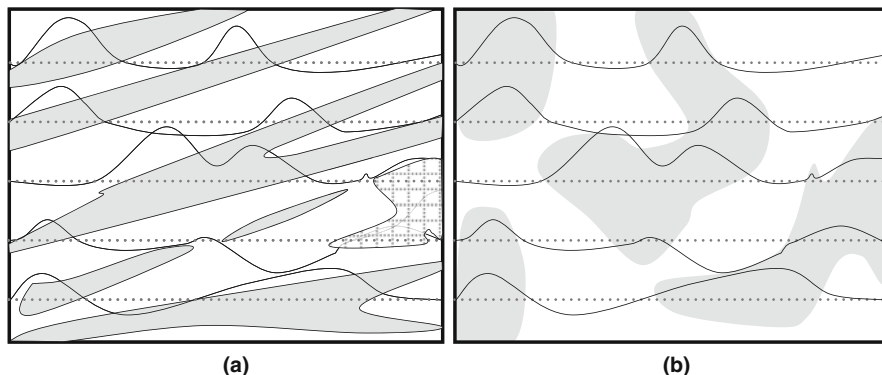

**Fig. 10.3** (a) Is a geological map of an ENE trending sequence of rock units. Magnetic intensity has been measured by close-spaced readings along a series of E–W lines – these values are shown on the map as a series of stacked sections. In (b), computer software has constructed a pixel map of the area based on the magnetic measurements. The spurious patterns of the pixel map result from a bias in the software for trends at a high angle to the survey lines

triangles intersect.<sup>7</sup> The values along the sides of each triangle are then calculated on the assumption that the attribute is distributed in a linear way between any two data points (this is illustrated in the simple hand contouring example of Fig. C.1). The triangulated data can then be used as a basis for positioning contour lines or allocating values to the cells of a raster grid. Smoothing programs are then employed if necessary to remove any angular patterns created by the triangulation. This procedure works well provided the spacing of the sample/flight lines is small relative to the spacing of the real-world map-scale patterns of the attribute that is being measured. The process is inevitably biased in favour of those patterns in the data that lie at a high angle to the sample lines. If the distribution of data in the real world has strong directional trends that lie at a low angle to the direction of the sample lines, and the sample lines are widely spaced relative to the spacing of the real world patterns, then the software can produce a completely spurious and misleading 2D map, as illustrated in Fig. 10.3. Fortunately, even if you know nothing about the geology of the area being surveyed, it is often possible to spot where this has occurred. Where the data has been collected along lines at a low angle to real world linear anomalies, the computer generated 2D map typically shows a distinctive pattern of irregularly-distributed, “blobby” anomalies, with lengths equivalent to one or two line spacings, and trends that are at a high angle to the survey direction.

Since pixel maps are based on a net of geographically referenced numbers, these numbers can be manipulated mathematically by computer to enhance features of the map in a variety of ways. For example, boundaries between domains can be emphasized (a process known as edge enhancement). Greater or lesser emphasis can be

<sup>7</sup>This method of covering space with a tesseraet of adjacent triangles is known as Delauney triangulation.

placed on particular ranges of numbers by allocating more colours or tones to that range. Extreme values, or outliers, can be removed from the data sets. By using the value of the attribute as a third dimension, computer processing can display georeferenced data as a complex surface which, when rotated and viewed on a monitor from different angles, gives the visual impression of a three dimensional surface similar to a topographic surface. The pixel data from one image can be used to create a second image in which each pixel is displaced to the east by a small amount depending on the value of the attribute. This creates parallax difference between the images so that they can be viewed with a stereoscope to recreate the 3-D effect. The 3-D effect can also be enhanced by a false “illumination” of the surface from any particular angle. Different viewing directions or different illumination angles can be useful in enhance particular trends within the data.

The processing power, memory capacity and graphics ability of modern computers<sup>8</sup> combined with available software packages mean that processing GIS data can be now be done on relatively cheap lap top computers. New data can be seamlessly integrated to existing data bases and presentations of data can be queried, compared and analysed quickly and in real time.

---

<sup>8</sup>Almost certainly the result of the demands from gaming applications.

# Appendix A

## Notes on the Use of Graphical Scale Logging

Because some explorationists are unfamiliar with graphical logging, this appendix goes into some detail on how to use this style of core logging. It should be read in conjunction with the comments in Sect. 7.8.2. The description refers to the particular logging form illustrated in Fig. 7.16. The comments, however, apply to most graphical scale log forms and serve to illustrate the concepts behind this style of logging.

The form illustrated was designed at A4 size for convenience of use in the field (it has been photo-reduced to fit the page size of this book). Some geologists might prefer to work with an original A3 size form. However it is important to realise that the amount of detail that can be shown is a function of the scale chosen, not the size of the logging sheet. The original of the form is printed on heavy-duty paper to withstand outdoor use and frequent erasing. The labelling of the various columns on the form reflects the type of information which experience suggests should be acquired when drilling many mineralized areas. However, particular projects may require particular types of information to be recorded, and the columns can be re-labelled or re-allocated as found necessary.

If the forms are completed in colour (and this is strongly recommended), some information will be lost unless scanned copies are also made in colour.

The form is designed to be used in conjunction with a diamond drill hole summary form. This is a single sheet that accompanies the geological log and records summary assay data, summary geological data and survey information.

A very important part of such a summary form is the provision for a statement setting out the purpose and justification of the hole and what it is expected to encounter. To be of any value, this statement should be written down in advance of drilling (see Sect. 7.3).

The graphical scale logging form of Fig. 7.16 is divided into columns. In order to describe how to record drill core observations on to the form, the columns will be referred to in numbered order from left to right

### **A.1 Column 1 (Hole Depth)**

The hole depth in metres is marked off along this column according to the scale chosen. A scale of 1:100 will allow 20 m to be logged per A4 page; a scale of 1:50 will allow 10 m to be logged per page, and so on. It is recommended that the entire hole be logged initially at a semi-detailed scale (1:100 has been found by practice to be a good general scale). If necessary, areas of interest can be separately re-logged at a more detailed scale such as 1:50 or 1:10.

### **A.2 Column 2 (Core Recovery)**

This column is used to mark the advance of each barrel of core. The actual core recovered for this advance is measured and recorded in this interval as a percentage.

### **A.3 Column 3 (Core Quality)**

This column is provided for recording measurements of core quality such as RQD (Rock quality designator). If no RQD is required, the column is available to be relabelled for some other parameter.

### **A.4 Column 4 (Sample No.)**

This column is used to record the identification number of the sample taken for assay. It also enables the geologist to record the intervals chosen for assay as she logs the core, and facilitates the subsequent transferral of assay information onto the form.

### **A.5 Column 5 (Assay Results)**

These columns are designed so that important assay data relevant to the mineralization can be shown in juxtaposition with other related geological elements. The purpose in entering key assay numbers on the log sheet is to assist in drawing geological conclusions about the meaning of the assay data. There is only room only to write a few significant assays on to the form: the full assay data for the hole would of course normally be stored elsewhere in a computer retrieval system.

### **A.6 Column 6 (Mapping Logs)**

This is the pictorial log and provides a map of the core. By dividing the columns as shown, it is possible to provide up to four parallel maps. In this example, these maps are chosen to show lithology, structure, mineralization and alteration (the analogy

is with several mapping overlays that might be used for an air photograph). As with any map, the use of colour will maximize the information content. The lithological data on the core map are recorded according to a legend that is drawn up for each drilling project. A copy of this legend should accompany each drill hole log. A number of standard symbols that can be used are shown at the head of the form. Where the geology is not complex, some of these columns (e.g. lithology and structure) can be combined.

The pictorial log does not aim to give a detailed, near-photographic representation of everything that can be seen in the core. As with any geological map it presents a selection of what are considered to be the key geological elements. The down-hole depths of important contacts are accurately plotted, but the detail shown is to some extent symbolic. The aim is to preserve in a visual way the characteristic style and relationships seen in the core. Where complex or important relationships need to be shown in a more precise and accurate way, they should be sketched separately in the Geology notes (Column 8) of the log.

At a scale of 1:100 (or at less detailed, smaller scales) the width of a drill core would be less than 1 mm. In order to provide space to show observations it is therefore necessary to project the structures/lithologies seen in the core for several core widths on either side of the drill line, thus enabling a core map several millimetres wide to be made. By doing this, the horizontal and vertical scales of the core map remain the same and there is no distortion. A surface drawn at  $45^\circ$  on the mapping column represents a surface at  $45^\circ$  to the core axis (alpha angle).

Planar structural elements (bedding, lithology contacts, faults, veins, etc.) will usually be shown on the pictorial log in the view that gives the maximum core axis to surface angle. However, a special case exists where the hole is not drilled at right angles to the strike of the major planar structural element (usually the lithological contacts or bedding surfaces) within it. In this case, if the orientation of the core itself is known, it is a good idea to represent the attitude of this dominant structure on the pictorial log as the apparent dip that it would make on the drill section. The apparent dip will always be less than the true dip and can be quickly calculated as logging proceeds either by looking up a table of correction factors or by the use of a stereonet (see Sect. B.3.6 for how to do this). Plotting surfaces in this way on the pictorial log and drill section will facilitate correlation of major lithological units and structures between holes on the same section. The true orientation of the surface can then be recorded as a measurement in the Geology notes column.

The centre line of each of the mapping columns is the point at which the down-hole depth of a particular feature is recorded on the form, just as its intersection with the long core axis is the point at which the feature would be measured in the core.

## **A.7 Column 7 (Histogram Logs)**

The histogram enables the distribution of quantitative data to be shown as a function of hole depth. The type of measurements shown and the appropriate horizontal scale are chosen for each project. Percentage sulphide or percentage quartz are common variables which could be recorded. The use of colour will allow more than one



variable to be shown. Note that the mapping of the mineralization or alteration will often show considerable detail, and it may not be necessary to try to repeat this in a quantitative way as a very detailed histogram. In most cases, bulking percentage values over intervals of a metre should be sufficient.

Remember, the various columns of the form are meant to complement each other. It is not always necessary to repeat the same data in the different recording formats offered by the log form.

## **A.8 Column 8 (Geology Notes)**

The geology notes column allows recording of verbal or numerical qualifiers of information shown in the other columns. Information which cannot be otherwise shown is recorded here: for example, rock name, stratigraphic name, rock colour, texture and grain size; structural measurements; percentages of mineral components; precisely measured down-hole depths (note: most depths can be simply read off the vertical scale on the log with sufficient accuracy and do not need to be separately recorded); sketches illustrating complex relationships; and non-observational annotations such as comments, conclusions or predictions.

However, note that it is not necessary to fill in this column (or indeed any column) just because it is there – long runs of unchanging uninformative core should be expected to result in long runs of rather blank-looking log sheets.

What the column is not provided for is extended passages of descriptive prose.

## **A.9 Column 9 (Summary Log)**

The use of this final column is self-explanatory. It is essentially a simplified summary of the various pictorial log columns. The summary log is for the geologist to use as a quick reference, the draftsperson as a source for plotting the standard section, or the computer operator for entry to the digital exploration data base.

## **A.10 Remarks Area**

These lines can be used for any type of information. They have been found useful to record drilling data such as rod sizes, water loss, etc. They can also be used to show the legend for the pictorial log.

# Appendix B

## Oriented Drill Core: Techniques and Procedures

### B.1 Techniques for Orienting Drill Core

#### *B.1.1 Non-mechanical Means*

Very often rocks being drilled possess a well developed structure of known orientation, such as a regular bedding or cleavage. Since these surfaces can be seen in the core, they provide a ready means of orienting it. When choosing a structure to use in orienting core, it is important that it has a constant attitude throughout the hole. In this regard, a cleavage will have a more constant attitude than bedding, and so provide a more reliable surface for this purpose (Fig. B.1). If more than one cleavage is present (for example, S1, S2, S3 etc.) then the youngest cleavage present will in general have the most constant orientation throughout the hole (Annels and Hellewell, 1988). The surface chosen should lie at as low an angle to the core axis as possible (i.e. possess a low alpha angle). Surfaces at high angles to core (alpha angles at or close to  $90^\circ$ ) cannot be used to orient core by this method.

Once a structure of known attitude has been identified in core, it is easy to measure the attitude of any other structure of interest. The best way is to place the piece of core in a core frame that has been set up at the azimuth and inclination determined by the down-hole survey for that hole depth. The core in the frame is then rotated about its axis until the known structure is in its correct orientation as measured by a geological compass. It is then easy to measure the attitude of any other structure present in the rock by using a geologist's compass in the same way. More detail on the use of core frames is given in Sect. B.3.3.

#### *B.1.2 Mechanical Means*

Where little is known about the attitude of structures in the rocks being drilled, it is necessary to orient the core using mechanical means. Mechanical orientation of core is a relatively easy procedure, and should be standard practice when drilling in any unknown or structurally complex terrain (see Sect. 7.10 for a detailed discussion on when to orient core).

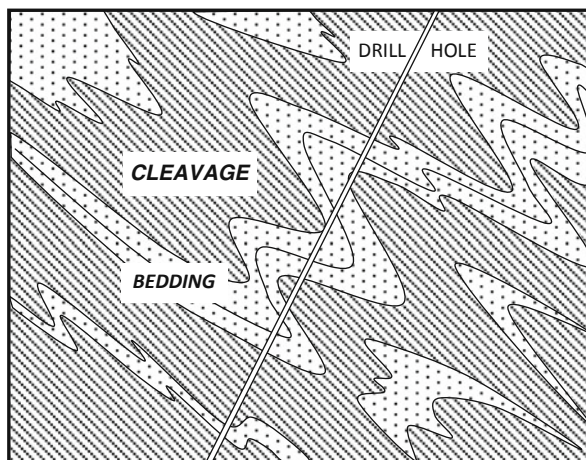

**Fig. B.1** Where structures of several ages are present in a deformed rock, the youngest structure present will have the most constant orientation. When using the known orientation of a surface to orient core, it is therefore better to use a late generation structure (e.g. use cleavage rather than bedding; S2 in preference to S1 etc. . .)

Orientation tools make use of the downwards pointing force of gravity (the gravity vector) to determine a Bottom Of Hole (BOH) position on a portion of the core that is still attached to the ground (i.e. core in its original orientation). Because of this, no matter how accurate the orientation tool, no core orientation is possible in vertical holes and progressively-increasing errors can be expected on holes inclined from the horizontal at more than 80°.

Measuring the gravity vector is relatively easy – all that is necessary is a weight free to find the lowest point of the tool. Determining the position of the down vector on core in its original orientation is very much harder. Two fundamentally different methods are employed to meet the requirement that core is still in its original orientation at the time of measurement:

1. With the *Core Stub Method*, orientation is carried out on the core stub remaining at the bottom of the hole after a run (barrel) of core has been drilled and extracted. At this stage the core stub is still attached to bedrock and will become the top of the next drilled run of core.

Different tools use different mechanical means to record the position of the gravity vector on the stub. The simplest device is the *core stub spear* (Fig. B.2). This consists of a heavy steel spear (sometimes called a core marking punch) with a sharp point. This type of orientation tool has been in use for longer than any other and was first described by Zimmer (1963). The spear is attached to the overshot (also known as the latch) assembly on the end of the wire line (Fig. B.1) and lowered down the inside of the rods after a barrel of core has been pulled from the ground. As it descends, the weight of the spear keeps it pressed against

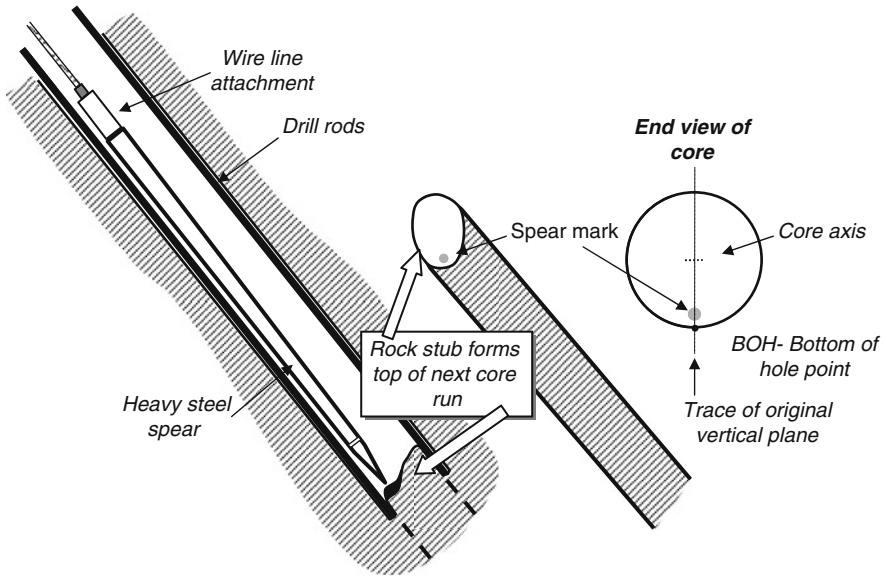

**Fig. B.2** Orienting core using a spear. The spear is lowered inside the rods after a full core barrel has been extracted. It makes a mark on the lowest point of the top surface of the core stub exposed at the bottom of the hole. This mark can be recovered after the next barrel has been drilled and pulled from the ground

the lower surface of the angled drill rods. The spear is allowed to strike the rock stub projecting into the bottom of the drill bit and (hopefully) leaves a percussion mark on the stub. This mark locates the Bottom Of Hole position on the stub. The rock stub becomes the top surface of the next run of core, and the percussion mark can be located when the core is extracted from the barrel. Problems with the spear arise when the rock is either too hard, or too soft and crumbly, to take a mark from the impact of the spear. With very hard material, the spear will either not leave a mark, or bounce (chatter) across the surface leaving a number of marks that can be hard to interpret. Most spears have an attachment that allows for a wax pencil or crayon to be substituted for the spear point and this will often make a better mark on hard material than a steel point. Consistently achieving successful orientation marks requires skill and experience on the part of the driller. The driller has to know when to use the point or the pencil, and how to judge and control the speed of impact of the spear with the core stub. In spite of these problems, spears are simple, cheap tools, whose mode of operation is readily understood. For that reason they are still quite popular and drilling companies will often make their own. Much historical drill core has been oriented by this method.

The other core-stub marking technique is the *core-stub template*. The template tool orients core by taking an impression of the shape of the top surface of the core stub. The system is sometimes known as the Craelius System and was first

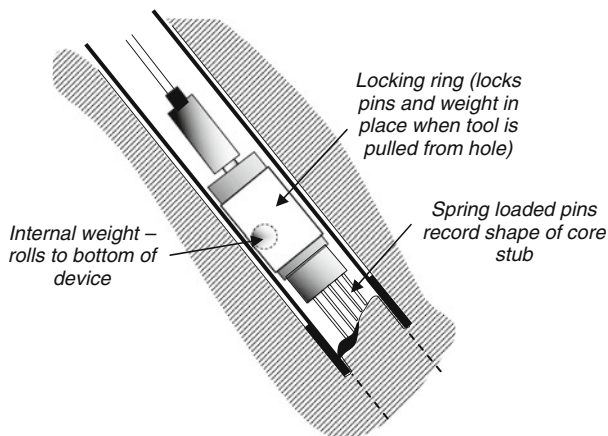

**Fig. B.3** Orienting core using a core-stub template tool (the Craelius system). The tool is lowered inside the rods after a run of core has been extracted. After drilling and extracting the next run of core, the shape of the core stub can be matched to the template pins, and the bottom of hole position (recorded by the locked weight) transferred to the core

described by Roxtrom (1961). Like the spear, the orienting tool is lowered down the hole on the end of the wire line overshot after a barrel of core has been extracted from the hole (Fig. B.3). A small weight is free to find its position at the bottom of the tool. Projecting from the base of the tool are a number of spring-loaded steel pins. When the tool reaches the bottom of the hole, the pins press against the rock stub and so take an impression of its shape. The action of pulling the tool from the hole locks the steel pins (which record the shape of the core stub) and the weight (which records the position of the gravity vector). When the next run of core is drilled and pulled from the ground, the template pins can be matched to the core end, thus enabling the BOH position to be marked on to the core. Template tools eliminate many of the problems with spears detailed above and have a generally higher success rate in orienting core. They work best on irregular core stubs, particularly those that lie at a low (alpha) angle to the core axis. However, if the core stub is smooth and at a high angle to the core axis, a spear will usually provide a better result than a template. As with spears, template tools will not orient very broken or crumbly core. A disadvantage associated with this system (and this applies equally with the spear) is that the core stub and template have to be matched as soon as the core is pulled from the ground and a BOH mark made on the core stub. This would normally be done by the driller, sometimes under less than ideal conditions, and there is no way of subsequently checking the BOH mark on the core.

In the last 10 years (since the first edition of this book) a sophisticated core-stub orientation tool has become available which offers high levels of accuracy, reliability and ease of use.<sup>1</sup> This tool has the following features:

<sup>1</sup>For more details see [www.2icaustralia.com](http://www.2icaustralia.com)

- It is mounted in the base of the core barrel before the barrel is dropped down the hole to take up its position behind the bit. After taking an impression of the core-stub, the tool automatically locks and is pushed back into the core barrel ahead of the advancing core: it is recovered when barrel and core are extracted at the end of a drill run. There is thus no need for the driller to lower the tool in a separate down-hole orientation procedure.
  - It combines both a template device to record core shape and a wax pencil to make a discrete mark on the core. It thus offers the advantages of both systems.
  - The weight is a steel ball that free to find the lowest level in an oil filled annular race: greater accuracy is achieved by mounting several such races in parallel. Accurate measurements with hole inclinations up to 88° are claimed.
2. With the *Core Barrel Method*, the orientation tool orients the *core barrel* at the moment when the core lifter (an integral part of the barrel) grips the lowest piece of the core in the barrel preparatory to breaking it free from bedrock. Since this piece of core remains locked in the lifter until freed by the driller at surface, the position of the gravity vector determined for the barrel can be directly transferred to the trapped piece of core. Core barrel orienting tools determine the gravity vector either by means of a weight or by electronic means. They can offer high levels of accuracy, but suffer from the disadvantage that core in the base of the barrel can sometimes – due to the action of drilling – break free from the bedrock and rotate by some unknown amount before it is gripped by the core lifter. Since this is the moment when the gravity vector is determined for the locked barrel/core system, large random errors are possible. There is no easy way of knowing when this has occurred, since the tool will always yield an apparently accurate result. Measurement errors (although not their specific cause) can be deduced after the core has been extracted and marked out through a large miss-match in BOH orientation lines between adjacent core runs. If there are no adjacent oriented core runs, or if marking out the core is done on a run by run basis (unfortunately, a common practice), the error may never be discovered and incorrect measurements will be made and entered into the data base.

In the author's opinion, all other things being equal, a system that measures the orientation of core *before* it is drilled will be much less subject to error than one which measures orientation *after* drilling. For this reason, core-barrel orienting tools are not recommended in this book.

All core orientation tools lead to the establishment of a bottom-of-hole (BOH) orientation mark on the end of a run of core (on the top surface in the case of core-stub tools and on the basal piece of a core run in the case of the core-barrel tools). This mark is used as the starting point to draw a reference line (BOH line) along the entire length of the core run, and along adjacent runs that can be matched to it. The next section explains how this is done.

## B.2 How to Handle Oriented Core

Extra handling procedures are necessary for oriented drill core. These are usually the responsibility of an experienced exploration technician.

Core pieces have to be first removed from the core tray and reassembled in a channel by carefully matching the broken ends of the core to form a continuous run. This process is essential if the core is oriented, but is a highly recommended step for all cores, whether oriented or not. The channel used should be as long as practicable but not be shorter than a standard core barrel (usually 3 or 6 m). The longer the channel in which the core is being reassembled, the easier and more accurate this process becomes. Channels are often made from vee-section lengths of metal or wood. One made by bolting two lengths of 50 mm polythene pipe edge to edge has been found to be very effective, and is light enough to be easily moved (Fig. B.4). If the core pieces cannot be fitted together in their original orientation, then core has been lost, and the orientation line cannot be transferred past this point.

When assembling the core, commence at one end of a run by placing the BOH orientation mark against one of the long edges of the channel. After re-assembly of as much of the core as possible, the straight channel edge can now be used to transfer the mark by drawing a line with a felt-tipped pen along the whole length of core (Fig. B.4). This line is referred to as the BOH line. It marks the intersection of a vertical plane (or drill section plane) with the lower surface of the core.

With very fragile core, the use of a split tube core barrel is often used to improve core recovery. In this case, provided the core pieces are still in their original orientation with respect to each other, the BOH line should be drawn along the length of the core, using a long straight edge, before removing it from the core barrel.

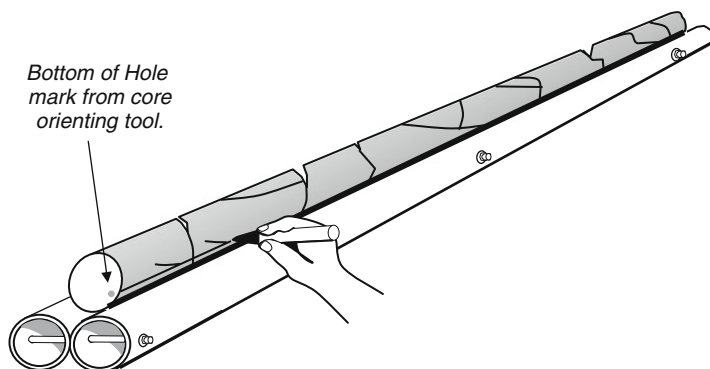

**Fig. B.4** A run of broken core pieces is carefully re-assembled in a channel with the BOH mark against the straight channel edge. The channel should be at least as long as a standard core barrel (3–6 m). The one illustrated is one made from two lengths of 100 mm polypipe. The straight edge is used to draw the BOH line along the length of the core. An *arrow* pointing down-hole is drawn on one side of this line on to each core piece

Wherever possible, the orientation mark on the top of one core run should be transferred (by matching broken core ends) to the bottom of the core from the preceding run. The BOH line can then be drawn both up-hole and down-hole from the mark. When adjacent core runs carry orientation marks, the degree to which the projected BOH lines match in the middle of the runs provides a good measure of the accuracy of the whole core orientation process. Considering the way these lines have been constructed, a slight miss-match between the two lines is only to be expected. However, a discrepancy of over  $10^\circ$  would indicate a significant handling error. If this occurs, the whole process of determining the BOH line from the core orientation mark should be repeated. If the discrepancy remains after checking, the section of core should be considered un-oriented, or, at the least, a note should be made on the drill log, and any measurements taken treated with caution.

Once the BOH line is drawn, it is recommended that the down-hole direction be marked with a small arrow (pointing down the hole) on to each separate piece of core. Where large continuous pieces of core have been recovered, an arrow should be marked at least every 25 cm along the core (Figs. B.4 and B.5). The arrows should be placed on the half of the core that will be retained after core is cut for assay (see Fig. 7.24). This practice ensures two things:

- It identifies the core half to be subsequently taken for assay (i.e. the half without the arrow).
- Orientation marks are preserved in the retained core.

In most cases it is not possible to orient the entire core from a hole. However, it is recommended that the non-oriented sections of the hole be marked using a

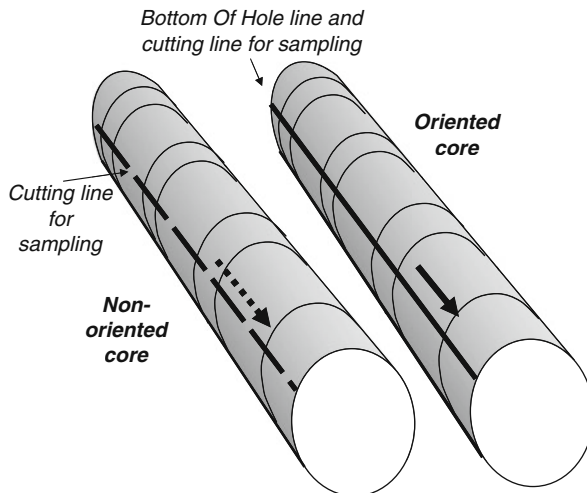

**Fig. B.5** When marking out oriented core, it is recommended that a *continuous line* be used for the BOH line and down-hole arrows. When marking a cutting line on non-oriented sectors of the core, use a *dashed line* and *dashed arrows*



down-hole line and arrows, in a similar way to that described for oriented core. If a dashed line and dashed arrow are used for marking out the non-oriented sectors of the hole, and a continuous line and arrow for the oriented sectors, the two categories of core can be distinguished when it comes to logging<sup>2</sup> (Fig. B.5). The down-hole line drawn on non-oriented core should be positioned to correspond, as nearly as can be judged, to a true BOH position, making use of internal structures in the core whose orientation is known from adjacent oriented sections of the hole. If no information is available as to the correct BOH position, then the dashed down-hole line should be drawn so as to lie at the highest angle possible to any dominant planar structure in the rock. The line will become the cutting line when the core is sawn to produce a half for assay.

### **B.3 How to Measure Structures in Oriented Core**

Structural observations and measurements should ideally be made on whole core before it is sawn in half. The attitude of planes should be recorded either as dip and dip direction, or as strike/dip/dip direction (see Sect. 2.1.6).

#### ***B.3.1 Before You Measure***

Examine the core to identify what structures are present and the relationships between them. This qualitative examination is a vital part of gaining an understanding of the history of the rock. The geologist should consider the following sorts of questions (this is not an exhaustive list):

- What structures are present?
- What rock elements define the structure?
- What are the relationships between the structures, lithologies, alteration and veining?
- What sectors of the core have constant attitudes of structure and what sectors show variability?
- Is the cleavage steeper than the bedding?
- Is the asymmetry sinistral or dextral?
- Is the hole being drilled at a low angle or high angle to particular structures?
- How do the structures seen in core fit with the larger-scale mental picture of the prospect that is evolving in the geologist's mind? In other words, does what you see reinforce or falsify your current hypotheses?

Once this qualitative examination of the core is complete the geologist is in a position to measure some of the structures that have been identified. By this stage it

---

<sup>2</sup>This is better than the alternative system of using different colours for the two types of line. Even in the absence of a key, it should be intuitively obvious that a dashed line has less certainty than a solid one.

should be known what structures need to be measured, and a context established in which the measurements made can be interpreted. What is more, the geologist is now in a position to decide how many, and from which parts of the core, measurements need to be taken.

### ***B.3.2 How Many Measurements Are Needed?***

Once a qualitative idea is gained of the structure present in the core, significant or representative examples of these structures are selected for accurate measurement of their attitude. These measurements are then used to construct accurate drill sections and maps and facilitate the precise predictions that are necessary to target additional holes. The purpose of measuring structures is not to compile impressive tables of numerical data, but to help provide answers to specific questions that arise as the core is being logged and interpreted.

The number of measurements that need to be made depends upon the variability of the structures present. If the attitude of a structure is relatively constant through a hole, then a representative measurement every 10–30 m or so down hole, would be quite sufficient to define it. As well as obtaining an even spread of measurements down the hole, at least one measurement should be obtained for each major lithology in the hole, with particular emphasis on features of economic interest such as vein orientations, or any banding or linear structure in ore.

Where the attitude of a structure is rapidly changing, more measurements are required to define this change – perhaps as many as one measurement of the structure every 3–5 m. Such detailed measurement would only normally be taken over limited sections of the core. The point is, as pointed out by Vearncombe and Vearncombe (1998) that routinely collecting hundreds of measurements from each hole according to some invariable rule, generally adds nothing to understanding. It is always far better to collect a small number of high quality measurements than a large number of low quality measurements. By “high quality” is meant that each measurement is carefully selected to be representative of a section of core, and the nature of the structure, its position and relationships with other structures, with mineralisation, alteration, host lithology etc. are all carefully observed and noted. A high quality measurement is also one that can be understood and recorded in geologically meaningful terms (i.e. as a strike and dip or a trend and plunge) at the time that it is made. Numbers that have meaning only after subsequent computer processing, when memory of the rock that was measured has faded, are, in this context, considered to be low quality measurements (see discussion Sect. B.3.5).

Measuring the attitude of structures in oriented core requires the use of simple tools and techniques. How to make these measurements are described in the section that follows. There are two basic techniques:

- By using a core frame and geologist’s compass, and;
- By measuring internal core angles then calculating strike/dip or trend/plunge by mathematical or graphical means.

### B.3.3 Using a Core Frame

Core frames<sup>3</sup> offer the simplest and most readily-understood way to measure structure in oriented core. For most applications, they also offer the most accurate and useful technique. “Core frame” is used here as a generic term for a number of devices – some of which are illustrated in Fig. B.6. They are all basically simple tools that allow a piece of core to be positioned in the same orientation as it was when in the ground. Once core is set up in the frame, structure can be measured using a geological compass, in much the same manner as the same structure would be measured in outcrop.

The core frame should be set up near to the trays of core being logged, but in a position where a compass will not be affected by magnetic disturbance from adjacent iron objects. The frame should be placed on a low wooden or plastic box or table so that it is possible to easily view the frame from all sides, and from above. Before placing core in the frame, the channel (or clamp) which holds the piece of core is oriented to match the azimuth and inclination of the drill hole at the depth from which the core was taken. The oriented core is then placed on the channel with the BOH (bottom-of-hole) line facing down, and the down-hole arrow marked on

**Fig. B.6** Some simple, and not so simple, core orientation frames. (a) A sand box, an always available, quickly-constructed device for measuring planes and lineations that are exposed as or on the top surface of a piece of core; (b) an expensive, commercially available frame by Combat Engineering. This is a highly engineered solution in which strike/dip or trend/plunge can be read directly off built-in scales without need of a compass; (c) a wooden frame made by the author – simple, compact and effective; (d) an aluminium model designed at James Cook University (Laing, 1989, Core orienting kit: Description and instructions, unpublished). It features a rotatable base for easy azimuth setting

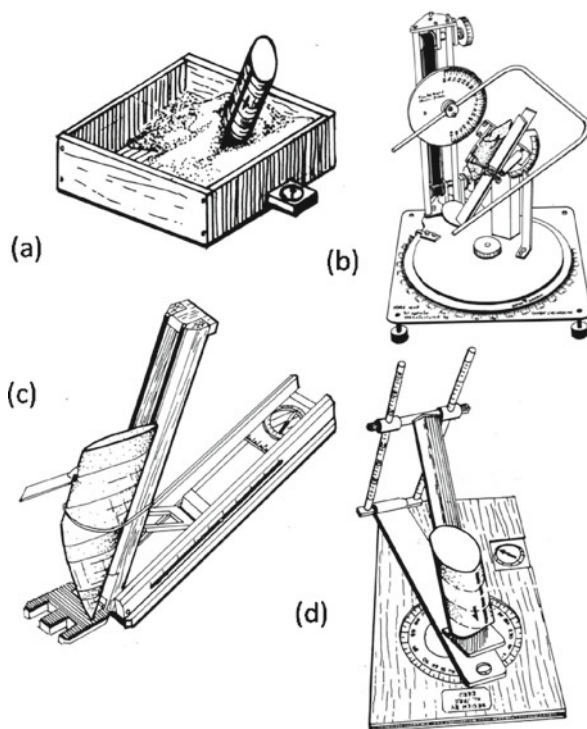

<sup>3</sup>An informal term often used for these devices is “rocket launchers”.

the core piece pointing down. Structures within the core can now be observed and measured.

Sometimes a structure is exposed either as or on the top broken surface of the core and so can be measured directly with a compass. However, in the more general case, the structure to be measured can only be seen as its trace on the surface of the core. If the surface is steep dipping, its trace on the core surface is relatively easy to measure by sighting onto the surface with a compass. However, with shallower dipping surfaces (say with an original dip of less than  $40^\circ$ ), it becomes increasingly more difficult to make an accurate compass measurement using this technique. The solution lies in the use of extension planes and rods, as described below.

To measure a plane within a piece of core oriented in a core frame:

- An assistant aligns a small oblong of plastic or card to lie parallel with the structure in the core – a notch cut in the card will enable it to fit over the core.
- The strike and dip of the extension plane is then measured with a geological compass in the usual way, by sighting onto the card (Fig. B.7).

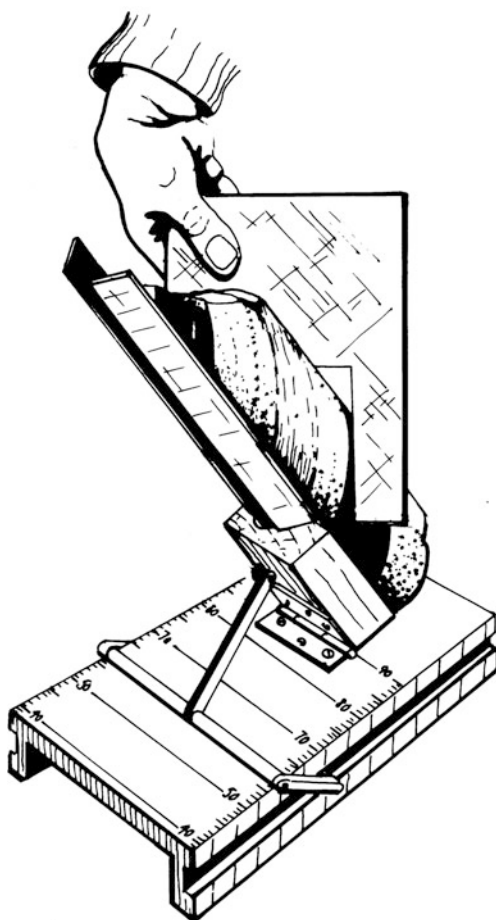

**Fig. B.7** Using an extension plane as an aid in measuring the attitude of planar structures in oriented core set up in a core frame. In a similar manner, a small rod (i.e. a pencil) can be used to extend a linear structure. It is best if an assistant holds the extension plane or rod while the geologist takes the measurement. Core frame design by author

**Fig. B.8** Illustrated are core pieces containing planar and linear structures set up in their original orientation in a core frame. Extension planes and rods are attached to the core surface with adhesive putty and manipulated so that they lie parallel to the internal structure of the core. This greatly facilitates accurate measurement with a geologist's compass. Allowing a few drops of coloured liquid to run down the extension plane will establish the vertical – useful for accurate measurement of dip on shallow dip surfaces

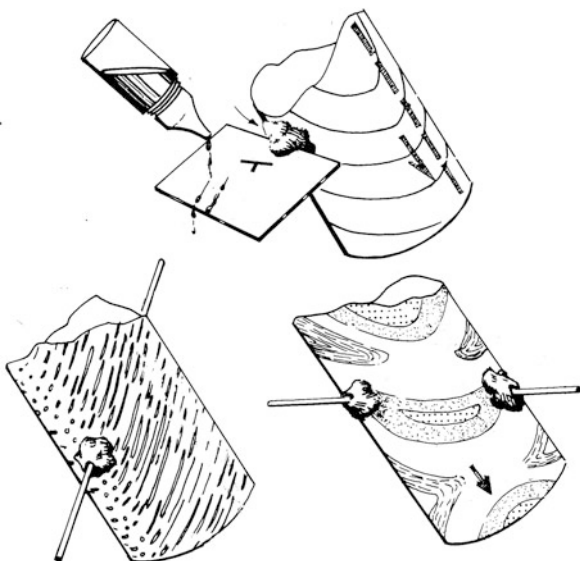

James Cook University of North Queensland has developed a way of using extension planes and rods with drill core which enables accurate measurement to be made without the need for an assistant (Laing, 1989, Core orienting kit: Description and instructions, unpublished). This is how it is done (Fig. B.8):

- Attach a small oblong of plastic to the outside of the core using Blu-Tac™ or similar self-adhesive putty. A piece of plastic the size, weight and stiffness of a credit card is ideal.
- By sighting onto the extension plane from several directions it can with great accuracy be pushed into alignment with the internal plane of the core that is being measured (fortunately, the human eye is a very good judge of the parallelism of adjacent planes and lines).
- If a trickle of coloured liquid is allowed to run down the face of the extension plane it will provide a guide for a very accurate measurement of dip and dip direction (Marjoribanks, 2007). A small dropper bottle of coloured liquid (use washable ink) should be kept for this purpose.

Measuring a linear feature in a piece of oriented core is done in a similar manner to measuring a plane, only in this case, extension rods are fastened to the core surface at the points where a single chosen linear feature enters and leaves the core. In this case, the rods attached to the core surface are tilted so as to lie on a single straight line when sighted from a number of different directions (Fig. B.8). Once aligned, the compass is used to measure the trend and plunge of the linear by sighting down on to the extension rods in the same manner as a linear would be measured in the field (see Appendix E).

### ***B.3.4 Using Internal Core Angles***

#### **B.3.4.1 The Angles that Define Planar Structure**

The angle which structures make with internal reference lines and planes in oriented core can be used to calculate the attitude of these structures to the standard geographical axes – that is, the vertical axis and north-south: east-west axes (Goodman, 1976, 1980; Reedman, 1979). The core reference lines used are the core axis and the BOH line. The core reference planes are the vertical plane and the core circumference plane. The orientation of the core reference lines and planes are known from down-hole surveys. The angles that a structure makes with these reference lines are measured in the core and then converted to the normal dip and strike, or trend and plunge measurements by mathematical or graphical calculation. A computer program would normally carry out this mathematical conversion. The graphical solution makes use of a stereonet.

As explained in Chap. 7, the intersection of cylindrical drill core with a plane is an ellipse (Fig. B.9). The long axis of the ellipse is marked by points of maximum curvature – called inflection points – located on opposite sides of the trace of the plane on the core surface. The inflection points of a number of closely-spaced parallel planes define an inflection line on the core surface. The ends of the long axis of the intersection ellipse are labelled E–E<sup>I</sup> where E is the lower end of the axis. The “lower” end of the ellipse axis (E) is the end that makes an acute angle with the down direction of the core axis. E<sup>I</sup> is the upper end of the ellipse long axis. The acute angle between the core axis (CA) and E–E<sup>I</sup> is the angle alpha ( $\alpha$ ) (Fig. B.9).

- Alpha is the first of the internal core angles that have to be measured in order to determine the orientation of the plane.

The geometric plane at right-angles to the core axis is the circumference plane and its hypothetical trace on the core surface is, of course, circular. A point defined on the trace of the circumference plane is its intersection with the BOH line along the core: this is known as the BOH point. The angle, measured in a clockwise direction,<sup>4</sup> around the circumference plane from the BOH point to point E, is known as angle beta ( $\beta$ ).

- Beta is the second of the two internal core angles that have to be measured in order to determine the orientation of the plane.

Armed with angles  $\alpha$  and  $\beta$ , and the azimuth and inclination of the core axis at the depth where the measurements were taken, the strike and dip (or dip and dip direction) of a planar structure can be determined. How to do this is explained below in section B.3.4.4.

---

<sup>4</sup>Clockwise when viewed looking down the core axis.

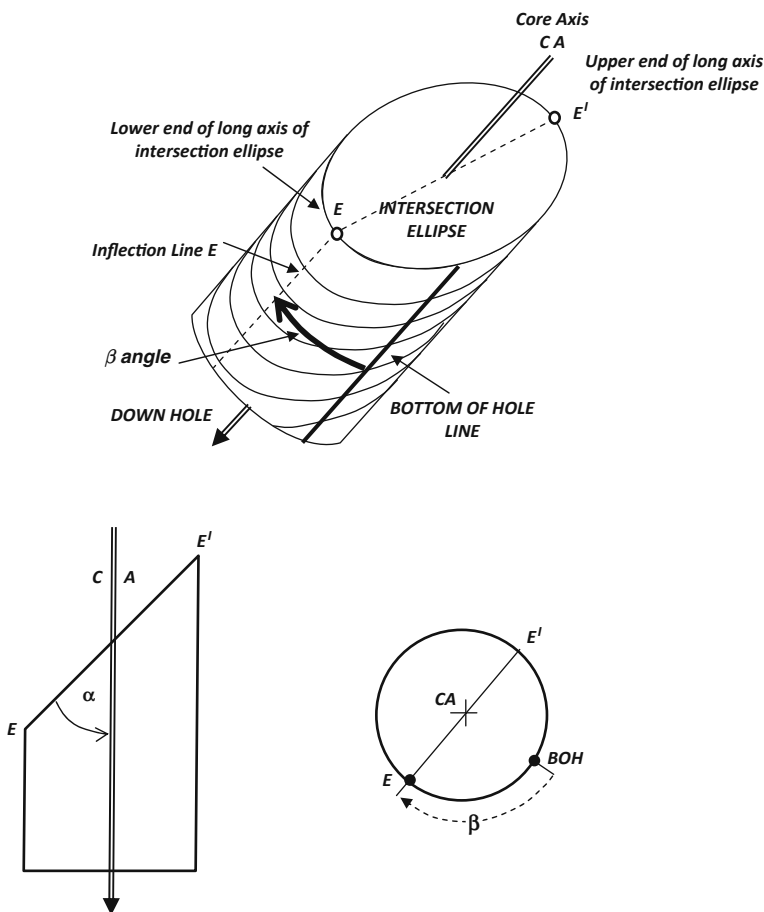
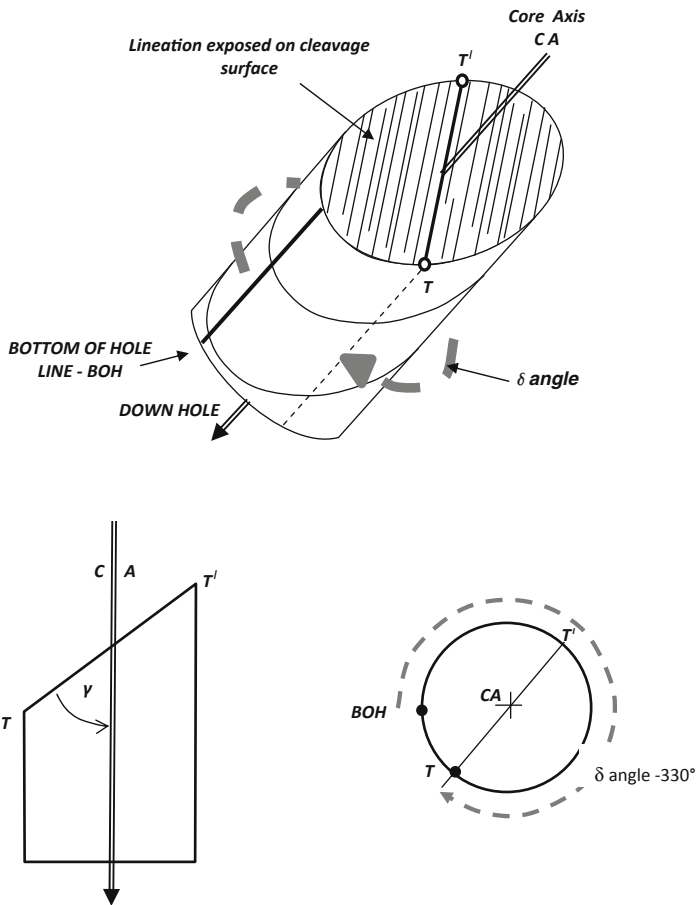

**Fig. B.9** Definition of the internal core angles alpha ( $\alpha$ ) and beta ( $\beta$ ) which define the attitude of a planar structure intersected by drill core

**B.3.4.2 The Angles that Define Linear Structure**

The only linear structures capable of being readily measured by the method of internal core angles are those that pass through the core axis. In practice, this means that only finely-penetrative mineral lineation, or an intersection lineation which is exposed where one of the defining surfaces forms the top of a core piece, will meet this criteria. All other linear elements, such as fold axes, or the long axes of boudins, can only be readily measured using a core frame.

Where a penetrative mineral lineation is intersected by drill core, those lineations that pass through the core axis are the ones with the smallest cross-section on the core surface. The set of similar intersections can form a distinctive band running along the length of the core (see Figs. 7.5 and B.8). A lineation passing through the



**Fig. B.10** Definition of the internal core angles gamma ( $\gamma$ ) and delta ( $\delta$ ) which define the attitude of a penetrative lination intersected by drill core

core axis is labelled T–T<sup>l</sup>. T is the point where the “lower” end (the “lower” end of the lination is the end that makes an acute angle with the down direction of the core axis) of the lination cuts the core surface; T<sup>l</sup> is the upper end of the lination (Fig. B.10). The acute angle between T–T<sup>l</sup> and CA is known as angle gamma ( $\gamma$ ). In the circumference plane, the angle between the BOH line and point T, measured in a clockwise sense, is known as angle delta ( $\delta$ ).

### B.3.4.3 How to Measure Internal Core Angles

A number of simple protractors can be made to simplify this job. Some of the designs, and how to use them, are shown in Figs. B.11 and B.12. In view of the accuracy with which the reference lines are defined in core, accuracy in measuring the internal angles of 1–2° will normally be found quite sufficient.



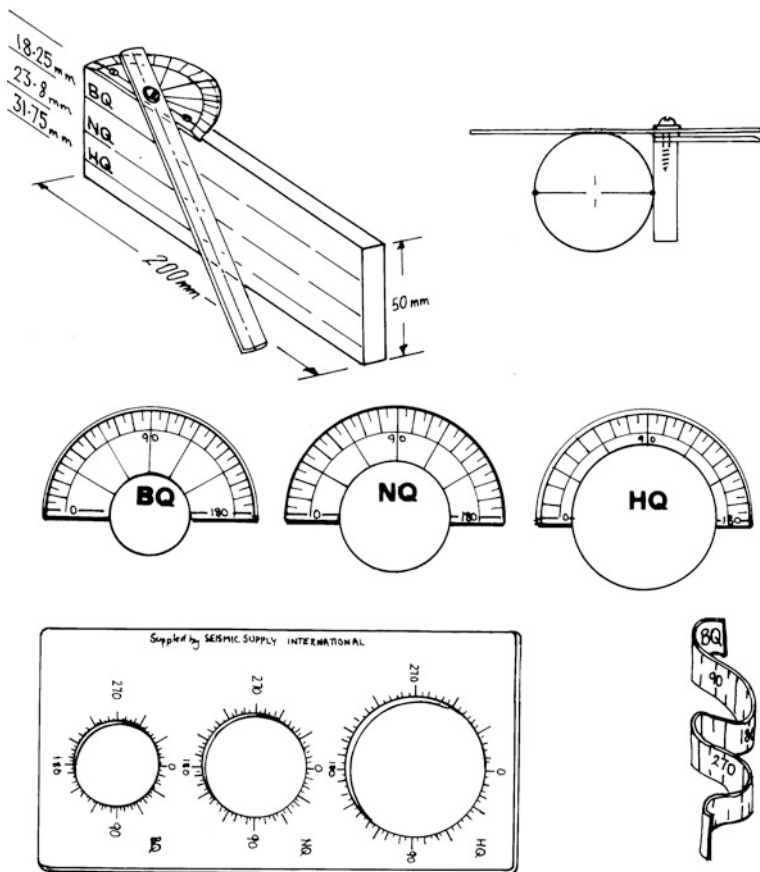

**Fig. B.11** Different protractors for measuring alpha and beta angles in drill core. At top is a home made protractor in perspex for measuring alpha angles. At centre: cheap 180° plastic protractors cut to fit different core diameters (these are probably the quickest and easiest way of measuring beta angles.) At bottom left is a commercial product for measuring beta. Bottom right illustrates another way of measuring beta – a tape the length of a core diameter marked off 0–360°

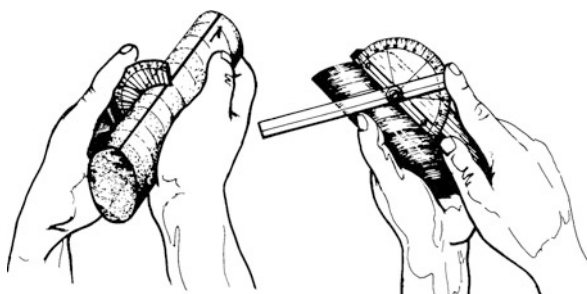

**Fig. B.12** Measuring alpha and beta in drill core

### B.3.4.4 Converting Internal Core Angles to Strike and Dip Measurements

Before any discussion of how internal core angles are converted into the familiar strike-dip measurement, it is worth pointing out that some sets of core angles can be converted by simple mental arithmetic. This point may seem rather obvious, but it is not unknown for geologists to mindlessly enter alpha/beta measurements into a computer for processing, where a trivial mental effort could have provided the answer. This would be akin to using computer software to add together two 2-digit numbers. As a corollary, if such angles have been entered into the program, they provide a quick way of checking the accuracy of the computer program, or, more particularly (since errors are unlikely in the software), of the data entry process. There are four special situations (Note, in the formulae below, “Az” stands for Azimuth and “In” stands for Inclination of the drill hole at the depth where the measurements were taken).

1. If  $\beta = 175\text{--}185^\circ$ , then drilling is normal to strike and in the direction of dip. In that case:

$$\text{Dip direction} = \text{Az}$$

$$\text{Dip} = \text{In} - \alpha$$

2. If  $\beta = 355\text{--}005^\circ$ , then drilling is normal to strike. There are three possibilities:

- a. Where  $\text{In} + \alpha \leq 90^\circ$ , then:

$$\text{Dip direction} = \text{Az}$$

$$\text{Dip} = \text{In} + \alpha$$

- b. Where  $\text{In} + \alpha \geq 90^\circ$ , then:

$$\text{Dip direction} = \text{Az} + 180^\circ$$

$$\text{Dip} = 90^\circ - \alpha$$

- c. Where  $\text{In} + \alpha = 90^\circ$ , then:

$$\text{Strike} = \text{Az} + 90^\circ$$

$$\text{Dip} = 90^\circ$$

3. If  $\alpha = 85\text{--}95^\circ$ , then drilling is normal to strike in the direction opposed to the dip.

$$\text{Dip direction} = \text{Az} + 180^\circ$$

$$\text{Dip} = 90^\circ - \text{In}$$

4. For all  $\alpha \geq 65^\circ$ , the inflection point E is not well enough defined on the core surface to permit a sufficiently accurate measurement of  $\beta$  (see below). In these cases, a core frame should be used to measure the structure.

#### **B.3.4.5 Mathematical Reduction**

This process involves spherical trigonometry or rotation of axes in three dimensions – it would not normally be attempted manually. However, geologists can simply key the measured alpha and beta angles into a software program<sup>5</sup> that will calculate the strike and dip of the plane (see Hoeks and Diederichs, 1989). To the best of the author's knowledge, there is no currently available computer program that can reduce the gamma/delta angles of a linear structure into a trend and plunge measurement.

#### **B.3.4.6 Reduction Using Stereonet**

The advantages of the stereonet solution, compared to using a computer, are:

- Conversion can be done on top of the core tray, as the core is being logged, thus allowing the geologist to fully understand and interpret the structures while they are still in view, and fresh observations can be easily made to check ideas or repeat/confirm key observations.
- When only a few measurements are involved in the course of core logging, using a stereonet is quicker than using a computer (allowing time to boot up, find the program and enter data).
- Plotting measurements on a stereonet provides a spatial visualisation of the data. This helps the geologist develop a three-dimensional picture of the rocks and so help solve structural problems.
- Plotting measurement on the stereonet is an invaluable tool in identifying any errors in the original measurements.
- Using a stereonet encourages a small number of quality measurements to be made. In structural geology, quantity seldom substitutes for quality.

Details of the stereonet solution for both planes and lines will be found in Appendix D.

#### **B.3.4.7 Problems with the Internal Core Angle Method**

Even where a planar structure is well defined in core, measuring an accurate beta angle can be difficult, and sometimes impossible. To measure beta, the point E has to be identified on the core surface. This is easy where the surface being measured is

---

<sup>5</sup>Several such programs are available commercially. One of the best known is DIPS (see [www.roscience.com/products/dips](http://www.roscience.com/products/dips)).

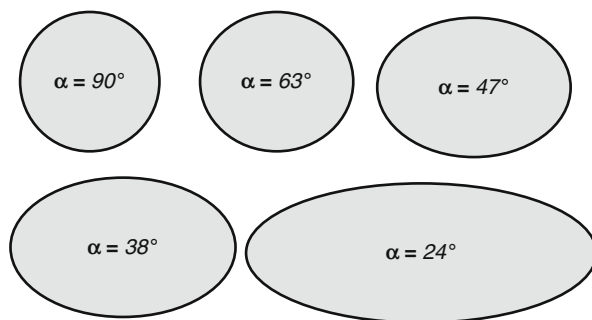

**Fig. B.13** Examples of intersection ellipses for planes at various angles to the core axis. As the  $\alpha$  angle between the core axis and the plane increases, so the intersection ellipse approaches a circle. Defining the position of the ellipse long axis on the surface of the core (necessary to measure angle beta) with any accuracy becomes difficult for any  $\alpha \geq 55^\circ$ , and all but impossible for  $\alpha \geq 65^\circ$ . For this reason, it is recommended that the internal core angle method for calculating the attitude of planes not be used where  $\alpha \geq 65^\circ$

at a low angle to the core axis (that is, the alpha angle is low) because this geometry gives an elongate intersection ellipse with well-defined inflection points. However as alpha approaches  $90^\circ$ , so the intersection ellipse approaches a circle and E becomes increasingly harder to define (Fig. B.13). For this reason, when making beta measurements, progressively increasing errors will occur for all planes with  $\alpha > 50^\circ$ . If the planes being measured are very well defined, regular and close spaced, an acceptable beta number might still be obtainable but in all cases, where  $\alpha > 65^\circ$ , it is recommended that the method not be used.

### ***B.3.5 Discussion on the Best Measuring Technique***

For most applications, it is recommended that a core frame be used to measure the orientation of structures. The main reason is that the frame permits direct visualisation of structures in their original orientation, and measurement of attitudes in geologically meaningful terms at the time of logging. If the method of measuring internal core angles is chosen, then a core frame must also be available in order to measure planes with high alpha angles. In addition, a core frame is the only way in which non-penetrative linear structures – such as fold axes – can be measured. In any case, where the internal core angle method is used, it is recommended that a stereonet be employed for direct reduction of the data, at the core tray, as the measurements are being made with direct entry of the strike/dip (or trend/plunge) on to the log sheet.

The internal core angle technique does however offer some advantages:

- Measuring alpha/beta angles is much faster than using a core frame.
- If the requirement is to make a very large number of measurements of a set of planar structures, whose identification and significance are otherwise well

understood, with a view to a statistical treatment of the results, then the internal core angle technique, with computer processing of the results provides the quickest and most effective option. This situation can arise, for example, in a mine application, in geotechnical logging or in the advanced infill drilling stages of prospect exploration. In this case, the internal angles would normally be entered directly onto a spreadsheet type of log form (or directly into a portable computer) for subsequent processing. Presentation will usually be in the form of a computer generated section or map, a stereonet pole figure or a histogram. However, even for these applications, the inherent limitations on the use of this method, for planes with particular orientations, need to be borne in mind.

- Measuring internal core angles may be the most efficient method of recording structure attitude onto analytical spread-sheet type logs during the advanced drilling stages of a prospect.

### ***B.3.6 Plotting Structure Measurements on Drill Section***

Once the orientation of a surface has been measured it can be plotted on to the drill section using a short line to represent to represent the trace of the surface, as described in detail in Sect. 7.7. If the hole is at right angles to the strike of the surface then the trace of the surface will be a single line plotted at the measured dip.

In the general case where the hole is not at right angles to the strike of the surface, the trace of the surface on a section will be an apparent dip. Apparent dips are always less than true dips. Very shallow dipping or very steep dipping surfaces are least sensitive to the direction of the section on which they are shown; moderately dipping surfaces are most sensitive. In order to plot a surface on a drill section the apparent dip has to be calculated. There are four methods available for calculating apparent dips (Travis and Lamar, 1987).

1. By using the formula below, where  $A$  = apparent dip,  $D$  = true dip and  $X$  = the angle between the section direction and the strike of the surface:

$$\tan A = \tan D \times \sin X$$

Most mining/exploration software programs will automatically calculate apparent dips using the above formula and plot them onto drill sections. Use of a trigonometric formula provides an exact answer for the apparent dip that is limited only by the accuracy of the input numbers  $D$  and  $X$ .

2. By using a table of apparent dips (Table B.1). This table was constructed using the above formulae and sets out the apparent dip of any surface for angles of true dip ( $D$ ) and different sectional orientations ( $X$ ) in  $5^\circ$  increments. For most measured true dips, Table B.1 will allow estimation of the apparent dip to  $2\text{--}3^\circ$ .

**Table B.1** Table for converting between true and apparent dips

Angle between direction of strike and direction of section																		
90	85	80	75	70	65	60	55	50	45	40	35	30	25	20	15	10	5	0
True dip°	Apparent dip°																	
0	0	0	0	0	0	0	0	0	0	0	0	0	0	0	0	0	0	0
5	5	5	5	4	4	4	4	4	3	3	2	2	2	1	1	0	0	0
10	10	10	10	9	9	9	8	8	7	6	6	5	4	3	3	2	1	0
15	15	15	14	14	14	13	12	12	10	10	9	8	6	5	4	3	1	0
20	20	20	19	19	18	18	17	16	14	13	12	10	9	7	5	4	2	0
25	25	25	24	24	23	22	21	20	18	17	15	13	11	9	7	5	2	0
30	30	30	29	28	28	27	25	24	22	20	18	16	14	11	9	6	3	0
35	35	35	34	33	32	31	30	28	26	24	22	19	16	13	10	7	4	0
40	40	40	39	38	37	36	35	33	31	28	26	23	20	16	12	8	4	0
45	45	45	44	43	42	41	39	37	35	33	30	27	23	19	15	10	5	0
50	50	50	49	48	47	46	44	42	40	37	34	31	27	22	17	12	6	0
55	55	55	54	53	52	51	49	48	45	43	39	36	31	26	20	14	7	0
60	60	60	59	58	58	56	55	53	51	48	45	41	36	30	24	17	9	0
65	65	65	64	64	63	62	60	59	57	54	51	46	42	36	29	20	11	0
70	70	70	69	69	69	68	67	65	63	60	58	54	49	43	35	25	13	0
75	75	75	74	74	74	73	72	71	69	67	65	62	58	52	44	33	18	0
80	80	80	80	79	79	78	78	77	76	75	73	71	67	63	56	45	26	0
85	85	85	85	85	84	84	84	83	83	82	81	80	78	76	71	63	45	0
90	90	90	90	90	90	90	90	90	90	90	90	90	90	90	90	90	90	0

Although this is sufficiently accurate for most purposes, for true dips between 30 and 60° and sections oriented at less than 50° to the strike of the surface, estimation from the table could produce errors of greater than 3°. In these cases it probably better to use one of the other methods listed here.

3. By using a specially designed plastic protractor/calculator. This simple device (available commercially) is a nomogram<sup>6</sup> which allows quick calculation of apparent dips to an accuracy of 1–2°. The tool was first described by Palmer (1918) and detailed in its modern form by Travis (1964). A plastic version is available commercially.
4. By using a stereonet. This is the procedure that the author recommends. It is probably one of the simplest stereonet calculations that can be made and takes about 10 s. Accuracy, for all orientations, is 1–2°. A worked example of an apparent dip calculation using a stereonet is given in Fig. B.14.

<sup>6</sup>A nomogram is a physical device that provides an analog graphical way of calculating a mathematical formula. A slide-rule is a nomogram. So is a stereonet.

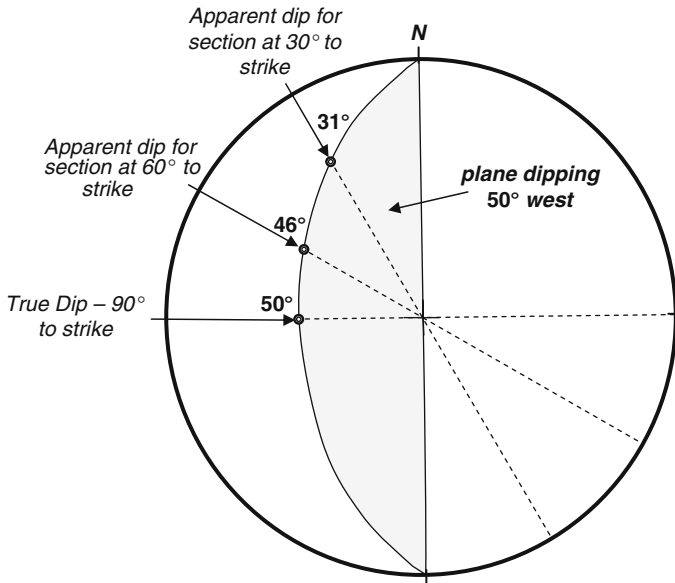

**Fig. B.14** How to use a stereonet to calculate an apparent dip. On the stereonet, planes plot as great circles. Vertical planes (drill sections) are straight lines passing through the origin. In this example, a bedding plane dipping 50°W is shown (shaded surface). The point where the straight line representing any given drill section intersects the bed is the apparent dip of the bed on that section and its value can be read off from the gradicules of the net. The procedure to calculate an apparent dip takes about 10 s

## References

- Annels AE, Hellewell EG (1988) The orientation of bedding, veins and joints in core; a new method and case history. *Int J Min Geol Eng* 5(3):307–320
- Goodman RE (1976) *Methods in geological engineering in discontinuous rocks*. West Group, Eagan, MN, 484p
- Goodman RE (1980) *Introduction to rock mechanics*. Wiley, New York, NY, 478p
- Hoeks E, Diederichs M (1989) *Dips version 2.0 users manual*. Advanced Version, 117p
- Marjoribanks RW (2007) *Structural logging of drill core*. Handbook 5, Australian Institute of Geoscientists, Perth, WA, 68p
- Palmer HS (1918) Method for determining the depth and thickness of strata and the projection of dip. *USGS Professional Paper 120-G*. GPO, Washington, DC, 123–128
- Reedman JH (1979) *Techniques in mineral exploration*. Applied Science Publishers, London, 533p
- Roxtrom E (1961) A new core orientation device. *Econ Geol* 56:1310–1313
- Travis RB (1964) Apparent dip calculator. *AAPG Bull* 48(4):503–504
- Travis RB, Lamar DL (1987) Apparent dip methods. *J Geol Educ* 35(3):152–154
- Vearncombe J, Vearncombe S (1998) Structural data from drill core. In: Davis B, Ho SE (eds) *More meaningful data in the mining industry*, vol 22. *Bulletin/Australian Institute of Geoscientists*, Perth, WA, 67–82
- Zimmer PW (1963) Orientation of small diameter core. *Econ Geol* 58:1313–1325

# Appendix C

## Calculating Strike and Dip from Multiple Diamond Drill Holes

### C.1 The Three Point Problem

The need to determine the strike and dip of a planar structure from a number of drill intersections is one that occurs very frequently – this is often called the three-point problem<sup>7</sup> and every geologist should be familiar with the simple solutions to it (Marjoribanks, 2007).

Where a number of adjacent holes are drilled into a prospect, preparing composite drill sections and correlating sequences between adjacent holes can enable details of the large-scale structure to be deduced.

The attitude of any plane is fully defined if the position in 3D space of three or more points on that surface is known. Where three separate holes intersect the same marker bed, they provide three points of known position on that surface. From the intercept data, there are two ways of calculating the strike and dip. The first makes use of structure contours. The second involves the use of a stereonet. In the presentation of the solutions below, it is assumed that the bed to be measured has the same attitude in all three holes.

### C.2 Solution Using Structure Contours

Proceed as follows (see Fig. C.1):

- Step 1:* Determine the three-dimensional coordinates (i.e. northing, easting and height above a common datum) of each intersection of the marker bed in the holes.
- Step 2:* Plot the three bed intersection points on a map using the northing and easting coordinates for each intersection. Write the depth (often called the Relative Level, or RL) of the intersection beside each point.
- Step 3:* Draw a line joining any two pairs of intersections on the map. The height of the intersection at the beginning and the end of the line is already marked.

---

<sup>7</sup>Presumably in conscious or subconscious reference to Sherlock Holmes' 3-pipe problem.



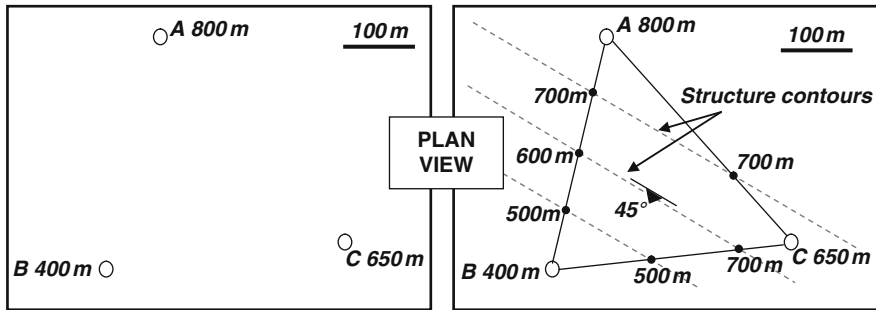

**Fig. C.1** Using structure contours to determine the strike and dip of a planar surface intersected in three drill holes. On the map at *left*, three drill holes have intercepted a common bed. The intercepts have been projected vertically onto the plan and labelled with their height above a common datum. On the *right* hand map, by constructing lines between each plotted intersection, the position of different heights along the lines can be scaled off. Structure contour lines (*dashed*) for the bed are constructed by joining points of equal height. These lines define the strike of the surface. From the map scale, the horizontal distance between lines of known height can be measured – simple trigonometry then allows the dip to be calculated

Using a ruler, scale off along the line to identify the positions of all intermediate depths along the line. Identify and mark even-number depth divisions on the line. Carry out this same procedure for the other two pairs of lines, marking on to the lines the same set of depth divisions as were marked on the first line.

*Step 4:* Draw the lines joining points of equal depth on the surface. These represent horizontal lines on the bed and they mark its strike. This strike can then be measured on the map using a protractor. The map projection of the trace of a horizontal line on a surface is known as a structure contour.

*Step 5:* Use the map scale to measure the horizontal distance ( $h$ ) between two widely spaced contour lines. Since the vertical separation ( $v$ ) of the contour lines is known, the dip of the surface ( $d$ ) can be calculated according to the formula:

$$\tan d = v/h$$

### C.3 Solution Using a Stereonet

Proceed as follows (see Fig. C.2):

*Step 1:* Determine the absolute position coordinates (i.e. northing, easting and height above a common datum) of each intersection of the marker bed in the three holes.

*Step 2:* Plot the three intersection points on a map. Use a protractor to measure the trend (bearing) of the lines joining the three points. Use a ruler to scale off

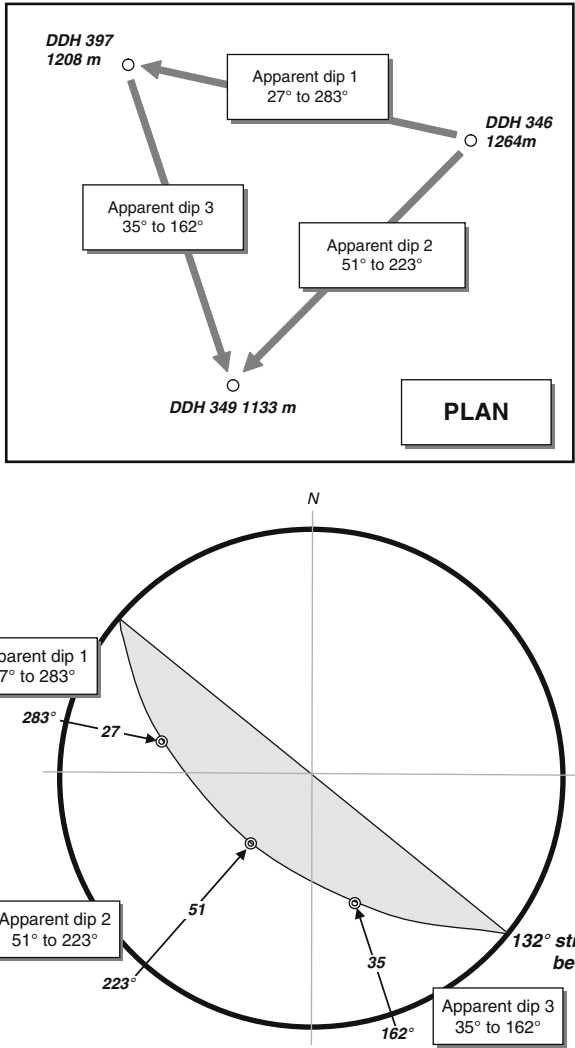

**Fig. C.2** Using a stereonet to determine the strike and dip of planar surface intersected in three drill holes. The intercepts are projected onto a plan and labelled with the height of each intersection above a common datum. The line that joins any pair of intersections is an apparent dip on the bed and can be described by its dip and dip direction. Where  $v$  is the vertical height difference between each pair of intersections, and  $h$  their horizontal separation, the apparent dip ( $a$ ) can be calculated using  $\text{Tan } a = v/h$ . The dip direction is measured directly from the plan with a protractor. Three apparent dips can be calculated in this way. On the stereonet, the three apparent dips plot as three points. The net overlay is rotated to bring the points to lie on a great circle girdle. This girdle is the plot of the bed and its strike (and true) dip can be easily read off. (Actually, only 2 apparent dips are necessary to define the surface, but using a third line provides extra accuracy.)

the horizontal distance between the points. Knowing the horizontal and elevation difference between any pairs of intersection points, simple trigonometric formulae (see Step 5 above) will provide the angle of plunge (the angle which the line makes with the horizontal, measured in the vertical plane) for the line that joins any two pairs of points.

*Step 3:* We have now calculated the trend and plunge of three lines lying on the surface of the marker bed. Mark these lines on to a stereonet overlay. They plot as three points, as shown on Fig. C.2.

*Step 4:* Rotate the overlay so as to bring the three points to lie on a common great circle. Only one great circle will satisfy all three points.<sup>8</sup> This great circle represents the trace of the bed that was intersected by the drill holes.

*Step 5:* From the net, read off the strike and dip of the surface (or dip and dip direction, or apparent dip on any given drill section).

## C.4 An Elegant Solution to Determining the Attitude of Planes in Non-oriented Core

Where there is no single marker bed that can be correlated between adjacent holes, it is sometimes still possible to determine the orientation of a set of parallel surfaces (such as bedding planes, a cleavage, or a vein set) provided that the surfaces have been cored by a minimum of three nonparallel drill holes (Bucher, 1943; Mead, 1921). The same technique can even be extended to a single hole, provided that the hole has sufficient deviation along its length for the differently oriented sectors of the same hole to be considered in the same way as three separate holes (Laing, 1977).

The stereonet plot of Fig. C.3 illustrates three adjacent but non-parallel angle holes that have intersected the same set of parallel, planar quartz veinlets. None of the core is oriented, but the average alpha ( $\alpha$ ) angle between the veins and the core axis has been measured in each hole: it is  $10^\circ$  in Hole 1,  $56^\circ$  in Hole 2 and  $50^\circ$  in Hole 3.

On a stereonet, the orientation (azimuth and inclination) of a drill hole plots as a point. The holes are the points labelled Hole 1, Hole 2 and Hole 3 on Fig. C.3.

When plotting planes on a stereonet it is always much easier to work with the pole<sup>9</sup> to the plane rather than the plane itself. If a plane makes an angle  $\alpha$  with the core axis, then the pole to the plane makes an angle of  $90-\alpha$  to the core axis, as illustrated in Fig. C.4.

Let us consider Hole 1. Angle  $\alpha$  and hence angle  $90-\alpha$  for the veins are known. Because the core is not oriented, the poles to the veins could lie anywhere within the range of orientations that is produced as the core is rotated one complete circle

<sup>8</sup>Actually, on a stereonet, only two points are needed to define a plane. The use of a third point adds accuracy and provides for error checking.

<sup>9</sup>The pole to a plane is the line at right angles, or normal, to the plane. By plotting the pole, the attitude of a plane can be represented on a stereonet by a single point.

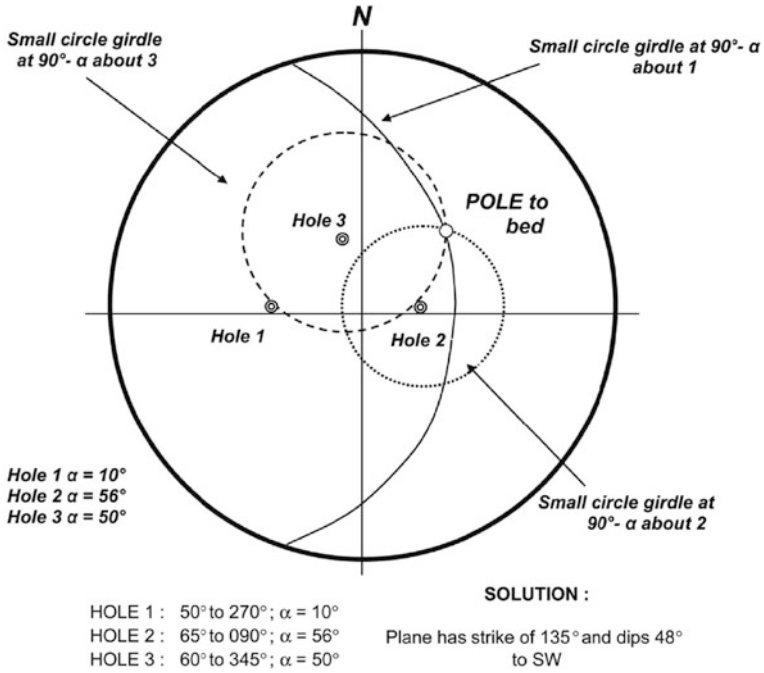

**Fig. C.3** If a set of parallel, planar surfaces (such as a penetrative cleavage or a vein swarm) is intersected by three non-parallel, non-oriented diamond drill holes, it is possible to use a stereonet to calculate the strike and dip. All that is necessary is an average value for the alpha ( $\alpha$ ) angle made by the structure in each drill hole. For a description of the method, see text

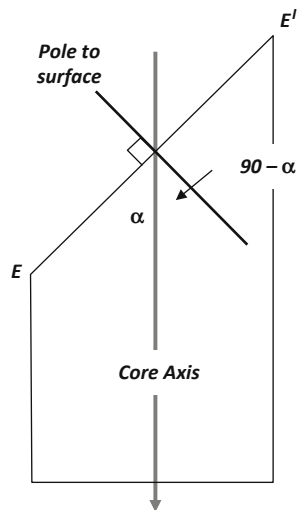

**Fig. C.4** The angular relationship of the alpha angle ( $\alpha$ ) to the pole (i.e. the normal) of a surface intersected in drill core

about its long axis. This range defines a cone, centred on the core axis, with an apical angle of  $2 \times (90-\alpha)$ . That is all we can tell from one hole, but this information can be shown on the stereonet, because a cone centred on a drill hole plots as a small circle girdle around that hole. In Hole 1,  $90-\alpha$  is  $80^\circ$ . The vein set in Hole 1 can therefore be represented by a small circle girdle at an angle of  $80^\circ$  to the hole plot.

Now the same procedure is carried out for Hole 2 by drawing a small circle at  $90-\alpha$  ( $34^\circ$ ) to the plot of that hole on the net. The small circle about Hole 1 and the small circle about Hole 2 intersect at two points – these points represent two possible orientations for the vein set. Now we draw the third small circle about Hole 3. We now have three small circle girdles, centred about each of the three drill holes, on the stereonet overlay. Since the assumption behind this procedure is that all measurements are of the one vein set with a constant orientation, the single point (P) where the three small girdles intersect must represent the pole to the one orientation that common to all three holes. This must represent the unique attitude of the common vein set seen in the holes. Of course, with a real set of measurements it is highly unlikely that the three lines would meet at a single point. Rather, the intersecting lines will define a triangle whose size reflects the accuracy of the measurements (and the assumptions made that we are dealing with a single parallel set of surfaces). The true pole position (if there is one) will lie somewhere within this triangle of error.

From the point P, the strike and dip (or dip and dip direction, or apparent dip on drill section) of the vein set can be simply read off from the net.

## References

- Bucher WH (1943) Dip and strike for three not parallel drill holes lacking key beds. *Econ Geol* 38:648–657
- Laing WP (1977) Structural interpretation of drill core from folded and cleaved rocks. *Econ Geol* 72:671–685
- Marjoribanks RW (2007) Structural logging of drill core. Handbook 5. Australian Institute of Geoscientists, Perth, WA, 68p
- Mead WJ (1921) Determination of the attitude of concealed bedding formations by diamond drilling. *Econ Geol* 21:37–47

# Appendix D

## How to Use a Stereo Net to Convert Internal Core Angles to Geographic Coordinates

### D.1 The Solution for Planar Structures

Where a plane has been measured using the internal core angles alpha ( $\alpha$ ) and beta ( $\beta$ ) it is possible to use a stereonet to calculate strike and dip. Here is how it is done:

*The theory:* The stereonet procedure described here is based on the fact that the Core Axis (CA), the pole (P) to the planar structure being measured, and the long axis of the intersection ellipse ( $E-E'$ ) all lie on a single plane. The line CA has a known orientation. The orientation of  $E-E'$  can be easily established through making use of the beta angle. With CA and  $E-E'$  plotted as points on a stereonet, there is sufficient data to define the plane (a great circle) that contains them. Once the great circle is defined, the unknown point P can be readily fixed because it lies on this great circle at an angle of  $90-\alpha$  from CA, in a direction measured from CA towards  $E'$  (see Figs. B.9 and C.4 for illustration of the terms above).

*Don't panic!* If the reader is not familiar with stereonets the above summary of the theory may be hard to follow. But don't worry; it is not necessary to understand the theory: the step-by-step process for obtaining the familiar strike and dip measurements from alpha and beta angles is quite simple. After a few determinations have been made, the procedure becomes routine and, for any one set of measurements, takes much less than a minute to do. In fact, the procedure is considerably easier to carry out than the large number of words and diagrams necessary to explain it might suggest.

Refer to the stereonet diagram of Fig. D.1 and follow the simple steps to find out how it is done:

*Step 1:* Mark a point on the net overlay to represent the azimuth and inclination of the drill hole at the depth at which the measurements  $\alpha$  and  $\beta$  were taken. Label this point CA. It will only have to be plotted once for all structures measured within that particular surveyed section of the hole.

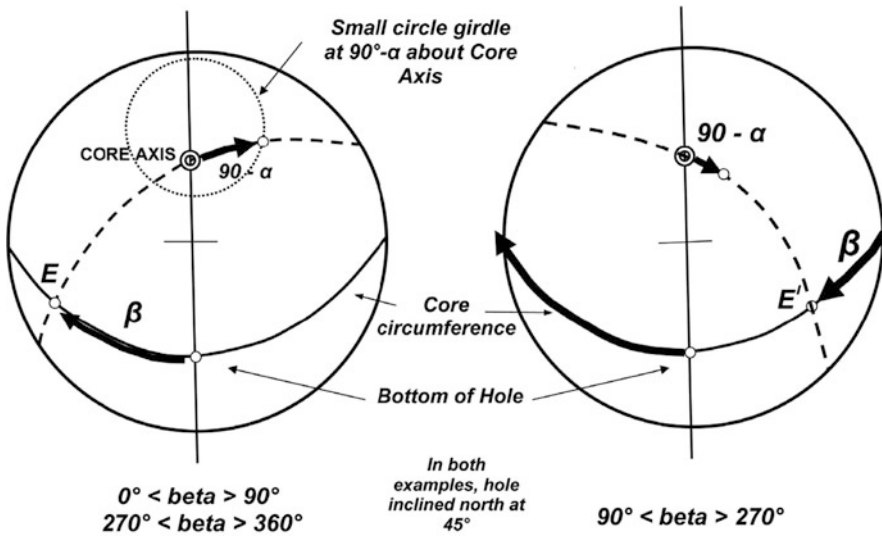

**Fig. D.1** Using a stereonet to plot the pole to a plane from measured alpha ( $\alpha$ ) and beta ( $\beta$ ) angles in drill core. See text for a detailed description of the method

*Step 2:* Plot the two principal reference planes of the core onto a stereonet overlay. These are:

1. The vertical plane passing through the core axis. This is the straight line through CA and the centre of the net.
2. The circumference plane (the plane normal to the core axis). This is the great circle girdle at  $90^\circ$  to CA.

Where these two reference planes meet is point BOH. This is the point from which the angle beta was measured. Initially, in order to understand the procedure, it will be helpful to trace the reference planes, and mark point BOH, onto the net overlay. However, with practice this will be found unnecessary.

*Step 3:* Using the printed graticules of the net, count off the measured angle beta around the great circle representing the circumference plane. Make the measurement in a clockwise direction from the BOH point. When you reach the net circumference (as will happen if  $\beta \geq 90^\circ$ ), continue to count off the degrees above  $90^\circ$  in a clockwise direction along the same great circle, but from the diametrically opposite point of the net. The point reached is marked on to the overlay as either E or E'.

If the beta angle lies between 0 and  $89^\circ$ , or between  $271$  and  $360^\circ$ , then the point marked on to the net is E. If beta lies between  $91$  and  $269^\circ$ , then point E' is plotted on the net. In the special case where beta is exactly  $90^\circ$  or

270° then both E and  $E^I$  will plot on the net, at diametrically opposite points of its circumference.

*Step 4:* By rotating the overlay over the stereonet, locate the great circle that contains the labelled points CA and E (or  $E^I$ ). Only one great circle will be found which passes through the two points. Trace this onto the overlay.

*Step 5:* Measure the angle  $90-\alpha$  by counting off degrees along the great circle marked on to the overlay at Step 4. Begin the measurement from the point CA in the direction away from point E. If point  $E^I$  rather than E appears on the net, then the angle  $90-\alpha$  must be plotted from point CA towards the point  $E^I$ . If both E and  $E^I$  appear on the net, then either construction will do. Once the new point is located, mark and label it "P". P is the pole to the original planar structure measured in the core.

*Step 6:* From point P, read off the orientation of the structure in whatever format is desired, for example as strike and dip, dip and dip direction or apparent dip on drill section.

## D.2 The Solution for Linear Structures

If a penetrative lineation has been measured using the internal core angles gamma ( $\gamma$ ) and delta ( $\delta$ ), it is possible to calculate trend and plunge using a stereonet. Here is how it is done:

The step-by-step procedure for determining the trend and plunge of a penetrative lineation is the same as that for a plane as far as Step 3 above. In Step 3, the measured delta angle ( $\delta$ ) is used to plot the point T or  $T^I$  in much the same way as the point E or  $E^I$  was located for a measured plane using beta. From this point proceed as follows (refer to Fig. D.2):

*Step 4:* By rotating the overlay over the stereonet, locate the great circle girdle which contains the labelled points CA and T (or  $T^I$ ). Only one great circle will be found which passes through these points – this represents the plane containing the core axis and the lineation.

*Step 5:* Measure the angle gamma ( $\gamma$ ) by counting off the degrees along the great circle plotted on to the overlay at Step 4. Begin from CA and measure the angle towards point T. If  $T^I$  rather than T is on the net, measure gamma from CA in the direction away from  $T^I$ . If both T and  $T^I$  appear on the net, then either construction will do. Once the new point is located, mark and label it L. L is the plot of the lineation measured in the core. The trend and plunge can now be simply read from the stereonet.

An alternative method of determining the lineation can be used where the orientation of the surface containing the lineation has also been determined. For example, where a lineation is exposed on the surface of a plane along which the core has been broken, the plane can be measured by its  $\alpha$  and  $\beta$  angles, and the lineation by its  $\delta$



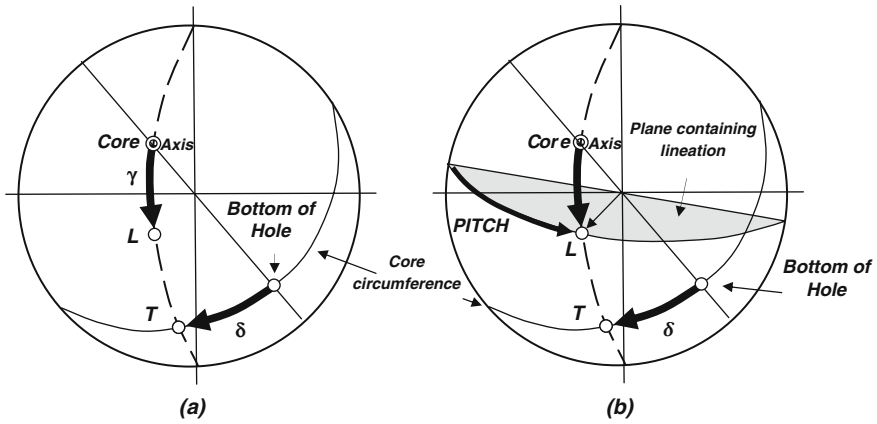

**Fig. D.2** (a) Using a stereonet to determine the trend and plunge of a penetrative lineation from measured gamma ( $\gamma$ ) and delta ( $\delta$ ) angles in drill core. See text for a detailed description of the method. (b) Using a stereonet to determine the trend and plunge of a lineation using the angle  $\delta$  and the orientation of the containing surface. See text for a detailed description of the method

angle. These three angles are sufficient to define both structures. To determine the attitude of the lineation, proceed as follows (Fig. D.2):

- Step 1:* Plot the pole to the plane on the stereonet as described above.
- Step 2:* Trace the great circle representing the plane onto the net.
- Step 3:* Use angle  $\delta$  to plot point T (or  $T'$ ) as described above
- Step 4:* Locate the great circle girdle containing T (or  $T'$ )
- Step 5:* L lies at the intersection of the two great circle girdles.

# Appendix E

## Practical Field Techniques

### E.1 Choosing the Right Compass

Great precision is not generally necessary when measuring geological structures in the field and most available geological compasses will do the job adequately. However, when choosing a compass for field work, look for the following features:

- An efficient damping system for the compass needle. An oil-filled compass provides the most efficient type of damping system.
- An adjustable compass card which can be set to compensate for magnetic declination (see below) or the orientation of a local grid.
- A compact and lightweight body.
- An ability to take measurements on small or inaccessible surfaces, including underlays. This can be an important requirement in mine mapping.
- An ability to take accurate survey bearings.
- Not too expensive.

Needless to say, no single geological compass currently available meets all these requirements. In particular, geological compasses are generally not sufficiently accurate for taking the bearings necessary in geographical surveying. To solve this problem, the author carries two compasses in the field: a general-purpose geological compass (a Brunton<sup>TM</sup> or a Silva<sup>TM</sup>), and a lightweight, compact, specialist compass designed for taking bearings (a Suunto<sup>TM</sup>).

### E.2 Understanding Your Compass

Compass needles work by aligning themselves with the lines of force of the earth's magnetic field, which, as a first approximation and over most of the earth's surface, trend N-S. The magnetic field is centred on the north and south magnetic poles which are located several hundred kilometres from the geographic poles around which the earth rotates. In addition, the position at surface of the magnetic poles is not fixed, but moves slowly and irregularly at a rate of tens of kilometres per

year. Magnetic compasses thus record a magnetic north direction ( $N^M$ ) rather than a true north ( $N^T$ ) direction. In tropical to mid latitude areas magnetic north may lie between 0 and  $20^\circ$  to the east or west of true north. However, the difference increases markedly in high latitudes with approach to the north and south magnetic poles. The difference between True North and Magnetic North at any given position on the earth's surface is called the magnetic declination.

The magnetic declination for any area is usually given in the legend of a published topographic or geological map as a rose diagram accompanied by a number in degrees. For example, a declination of  $10^\circ\text{E}$  (or  $+10^\circ$ ) indicates that, for the area of the map, Magnetic North lies  $10^\circ$  east of True North. A declination of  $10^\circ\text{W}$  (or  $-10^\circ$ ) indicates that Magnetic North lies  $10^\circ$  west of True North. In addition to declination, the map will also provide a date of publication and a statement setting out the rate of annual variation, or drift, in the declination. In most places the annual drift is measured in fractions of a degree per year and can generally be ignored unless the map you are using is many decades old.

You can make use of the following Table E.1 to convert from True North to Magnetic North, and vice versa. In the table,  $\delta$  is the amount of magnetic declination.

Compasses with a rotatable compass card (known as a bezel) such as the Brunton<sup>TM</sup> or the Silva<sup>TM</sup>, allow these corrections to be set on the compass so that the compass scale will automatically read true north or magnetic north as required. A similar correction can be made on these compasses to enable them to directly give bearings on a locally established grid.

The magnetic lines of force are horizontal at the equator but dip at ever more steep angles as the north and south magnetic poles are approached. The north-pointing end of the compass needle thus tends to dip below the horizontal in the northern hemisphere and above the horizontal in the southern hemisphere. Compass makers compensate for this effect by weighting the needle to enable it to lie approximately horizontal in mid-latitude areas. Different compasses are manufactured for northern and southern hemispheres. For this reason, compasses designed for the northern hemisphere are difficult or impossible to use in the southern hemisphere and vice versa. Mid-latitude compasses work adequately in tropical areas but may need to be tilted slightly to keep the needle swinging freely in the compass case.

**Table E.1** Converting true north to magnetic north and vice versa

Declination	To convert true north to magnetic north	To convert magnetic north to true north
$-\delta^\circ$ or W declination <sup>a</sup>	Subtract $\delta^\circ$ from $N^T$ bearing	Add $\delta^\circ$ to $N^M$ bearing
$+\delta^\circ$ or E declination <sup>b</sup>	Add $\delta^\circ$ to $N^T$ bearing	Subtract $\delta^\circ$ from $M^N$ bearing

<sup>a</sup>That is, magnetic north lies to the west of true north.

<sup>b</sup>That is, magnetic north lies to the east of true north.

### E.3 Measuring the Strike and Dip of Planes

This is one of the basic skills which every geologist is taught, but it may be worthwhile setting down a few helpful tips.

Taking a measurement by placing a compass along a rock face – although this may be necessary if this is the only surface available – only measures the portion of the surface in contact with the instrument. Wherever possible, a more representative strike should be obtained by sighting along a line of outcrop thus averaging the strike over that distance (Fig. E.1). Be careful, when doing this, to ensure that the line of sight is horizontal (however, any tilt on the compass sufficient to make the strike measurement substantially in error will also trap the compass needle against the face glass and so alert you to the problem).

Similarly, where a dipping bed is exposed on a vertical or near-vertical surface, the most representative dip is obtained by sighting the clinometer on that surface from a distance and so averaging the dip over the area of the outcrop (Figs. E.2 and E.3). This technique is only accurate if the sighting is made while looking along strike – otherwise an apparent dip is obtained. An apparent dip is always less than the true dip.

**Fig. E.1** Sighting with a compass along a line of outcrop to obtain an averaged strike direction. Caution – the line of sight must be horizontal



**Fig. E.2** Sighting with a geological compass along the strike of an outcrop to obtain the average dip of beds exposed on vertical surfaces. Caution, the line of sight must be parallel to strike



**Fig. E.3** Measuring the dip of beds on a distant mesa by sighting along strike



When measuring a plane with a small surface area, the plane can be extended to permit measurement by laying the surface of a notebook or map-board against the surface and then measuring the attitude of the extension plane so formed.

Determining the dip direction of small or awkwardly positioned planes can be difficult. A trickle of water down the surface of the plane can often solve this problem – heroic measures are not necessary here if a small dropper bottle of coloured liquid is kept handy in the field kit.

When measuring orientation on the underside of a plane, particularly when looking up at that plane (a problem that often arises in mine mapping), the use of a Silva<sup>TM</sup> geological compass is invaluable as its compass needle can be sighted from below as well as from above, and the bezel can be rotated to record the position of the needle. For that reason, the Silva<sup>TM</sup> has some advantages over other types of compass for mine mapping. Some specialist geological compasses (such as the Freiberg<sup>TM</sup> geologists' compass or the Cocola<sup>TM</sup> compass manufactured by Breithaupt Kassel) will also measure on an underlay, but these compasses are larger and often cannot fit into a confined space. They are also much more expensive instruments.

Some recent models of geological compass, such as the Tectronic made by Breithaupt Kassel, offer automatic electronic measurement of dip and dip direction. The measurements can be stored in the instrument memory against keyed-in code numbers, displayed on a liquid crystal display and downloaded to computer. This instrument would be valuable in applications where large numbers of orientation measurements need to be taken (e.g. some specialist structural or geotechnical applications), but they are relatively expensive; for most applications, the traditional low-tech geologists' compass will do everything that the field geologist requires.

## **E.4 Measuring the Trend and Plunge of Lineations**

Measurable linear features encountered in rocks can be fold axes, elongate boudins, mullions, preferred elongations of minerals or mineral aggregates, elongated clasts, slickenlines or the intersection of two surfaces (such as bedding and cleavage). All

these will be collectively referred to here as linears. Linears are important and provide vital clues towards unravelling geology and mineralization in deformed rocks. Linears are easy to measure and record and this should be done routinely when field mapping or logging drill core.

In the author's experience, many geologists are not quite sure how to measure and record lineations, hence the following detailed description. It is based on the use of a Brunton™ compass but other geological compasses can be used. However, the slotted and horizontally extendable sight on the Brunton makes the procedure particularly easy.

Linear features within a rock are defined geometrically either by their trend and plunge, or, if they lie upon the surface of a plane, by their pitch upon that plane. These terms are defined on the block diagram of Fig. E.4. The pitch will only define the absolute orientation of a linear if the attitude of the plane on which the pitch is measured is also known. Given either of the two sets of measurements, the other can be calculated mathematically or by stereo-net. For general mapping purposes it is usually more useful to measure and record the trend and plunge of the structure, but in some situations, particularly when working in mines, it may be easier to measure pitch.

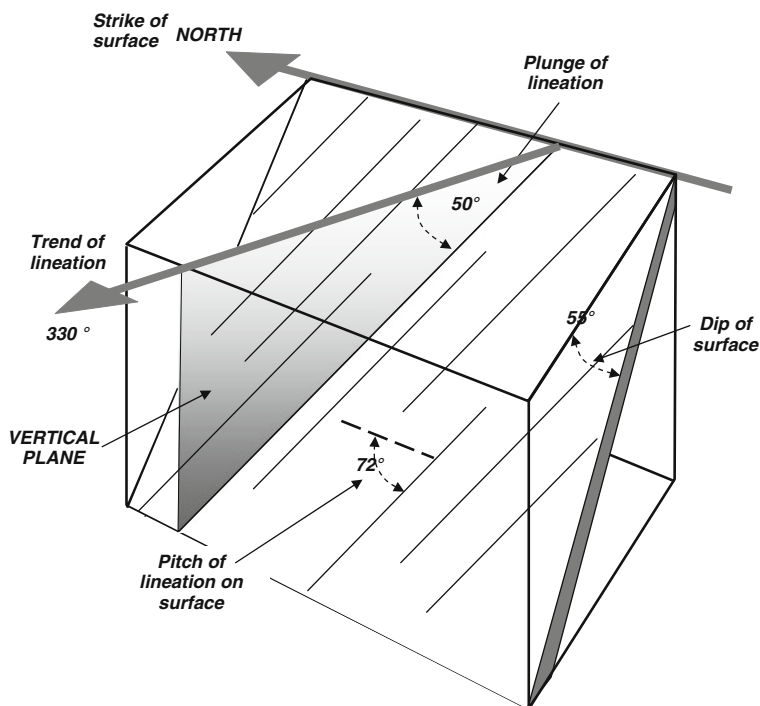

**Fig. E.4** Block diagram defining the strike and dip of a surface; the trend and plunge of a lineation and the pitch of a lineation on a surface

**Fig. E.5** Measuring the trend of a lineation with a Brunton™ compass

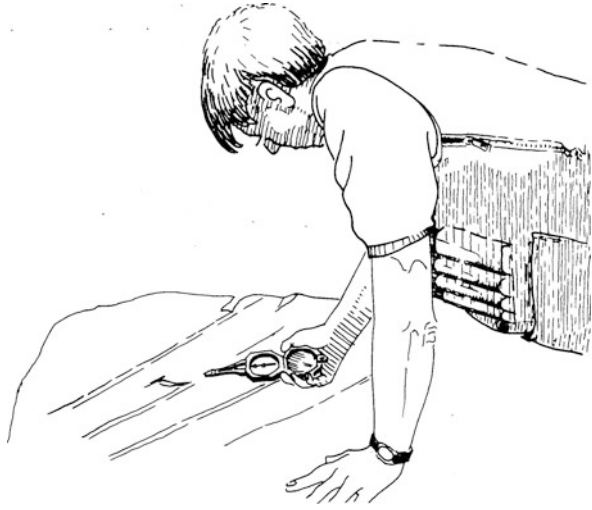

The recommended field procedure for measuring lineations is as follows:

- If the linear to be measured is not clear in the rock, mark it with a felt-tip pen, or lay a pencil along it, before making the measurement.
- Hold an open Brunton compass horizontally<sup>10</sup> above the linear with the slotted sighting bar horizontally extended (Fig. E.5). Sight vertically down on to the linear through the slot in the sighter, rotating the compass in the horizontal plane so that sighter bar and linear are aligned. Use the thickness of the sighter bar to judge whether the view is vertical down on to the linear (when the view is from



**Fig. E.6** Measuring the plunge of a lineation with a Brunton™ compass

<sup>10</sup>The Freiberg structural geology compass will measure trend and plunge of lineation directly.

above, the edge of the bar – its thickness – cannot be seen). Record the bearing on the compass card – this is the trend of the linear feature.

- Next, lay the long edge of the open compass against the linear and, holding the compass body vertically, measure the angle that the linear makes with the horizontal (Fig. E.6). This angle is the plunge of the lineation.
- The orientation of the linear feature is recorded on to the map using an arrow pointing to the direction of trend, and a number indicating the amount of plunge. Different types of arrow can be used for different types of lineation.



# Appendix F

## Suggested Further Reading

### General

Berkman DA (Compiler) (1991) Field geologists' manual, 3rd edn, Monograph 9. The Australasian Institute of Mining and Metallurgy, Melbourne

*This is an invaluable source for the thousand and one useful facts and figures that every field geologist will at some time need. If you own no other book, get this one.*

Peters WC (1987) Exploration and mining geology, 2nd edn. Wiley, New York, NY, 685p

Reedman JH (1979) Techniques in mineral exploration. Applied Science Publishers, London, 533p

*Although now somewhat dated, these are still excellent detailed texts on the practical field aspects of exploration geology.*

### Chapter 1

Guilbert JM, Park CF Jr (1986) The geology of ore deposits. WH Freeman, New York, NY, 985p

*A comprehensive and well-written text on the geology of ore deposits.*

Kirkham RV, Sinclair WD, Thorpe RI, Duke JM (eds) (1993) Mineral deposit modelling, vol 40. Geological Association of Canada, Special Paper, St. John's, NL, 798p

*An excellent compendium on ore deposit models and their use in developing conceptual exploration strategies*

## Chapter 2

- Australian Institute of Mining and Metallurgy (1990) Geological aspects of the discovery of some important mineral deposits in Australia, Monograph 17. Australian Institute of Mining and Metallurgy, Melbourne, 503p
- Barnes JW (1995) Basic geological mapping, 3rd edn. Wiley, New York, NY, 133p  
*A practical coverage of field geological mapping techniques.*
- Hancock PL (1985) Brittle microtectonics: Principles and practice. *J Struct Geol* 7:437–457  
*A useful and practical review paper on the recognition and interpretation of sense of movement indicators in brittle fracture zones.*
- Hobbs B, Means W, Williams P (1976) An outline of structural geology. Wiley, New York, NY, 571p  
*A general text on structural geology, relatively cheap, and written by experienced field geologists. In the author's opinion, in the crowded field of structural geology textbooks, this is still one of the best.*
- Hutchinson RW, Grauch RA (eds) (1991) Historical perspectives of genetic concepts and case histories of famous discoveries, Monograph 8. Economic Geology, Lancaster, PA  
*Case histories of geological aspects of mineral discovery.*
- Marshak S, Mitra G (1987) Basic methods in structural geology. Prentice-Hall, New York, NY  
*A good treatment of the philosophy of geological mapping.*
- McClay K (1987) The mapping of geological structure, Melbourne (1990), Monograph 17. Halstead Press, London, 503p  
*On the field observation and use of ductile deformation structures.*
- Turcote DL (1992) Fractals and chaos in geology and geophysics. Cambridge University Press, New York, NY, 221p  
*A detailed discussion of some of the applications of chaos theory in geology.*
- Wolf PR (1983) Elements of photogrammetry, 2nd edn. McGraw-Hill, New York, NY  
*For the basic theory of air photo stereoscopy, measurement of features seen on air photographs and the production of maps.*

## Chapter 4

MacDonald EH (1983) Alluvial mining: The geology, technology and economics of placers. Chapman & Hall, London, 508p

*Detailed information on the geology and exploration of unconsolidated placer deposits.*

## Chapter 5

Annels AE (1991) Mineral deposit evaluation: A practical approach. Chapman & Hall, London, 456p

*A comprehensive coverage of all aspects of the evaluation of mineral deposits, with an emphasis on advanced exploration projects and ore deposits.*

Petit JP (1987) Criteria for the sense of movement on fault surfaces in brittle rocks. J Struct Geol 9:597–608

*The recognition and interpretation of sense of movement indicators in brittle fracture zones.*

Hanmer S, Passchier C (1991) Shear sense indicators: A review, Paper 90-17. Geological Survey of Canada, Ottawa, ON, 72p

*A detailed and well illustrated treatment on the recognition and interpretation of sense of movement indicators in shear zones.*

Sibson RH (2001) Seismogenic framework for hydrothermal transport and ore deposition. In: Richards JP, Tosdal RM (eds) Structural controls on ore genesis, Reviews in Economic Geology, vol. 14. Society of Economic Geologists, Littleton, CO, 25–50

*An excellent detailed review paper that provides a summary of fluid movement in fault zones and mineral deposition in dilational sites of the various classes of fault.*

Robert F, Poulsen KH (2004) Vein formation and deformation in greenstone gold deposits. In: Richards JP, Tosdal RM (eds) Structural controls on ore genesis, Reviews in Economic Geology, vol 14. Society of Economic Geologists, Littleton, CO, 111–155

*A must-read review paper by two of Canada's most distinguished structural geologists. Of great value to anyone working in gold exploration in Archaean greenstone or Palaeozoic slate belts.*

## Chapter 6

Barnes J (1987) Practical methods of drill hole sampling. Bulletin/Australian Institute of Geoscientists 7: Meaningful Sampling in Gold Exploration. Papers presented at Seminar No. 5, Perth, 26th Oct 1987, Sydney

*The title is self-explanatory.*

Barnes J (1989) RAB drilling – Secret weapon. Resource Service Group Pty Ltd, Resource Review, 5–7 Oct 1989

*RAB and RC drilling and sampling techniques in mineral exploration.*

## Chapter 7

Australian Drilling Industry (1997) Drilling: The manual of methods, applications and management, 4th edn. CRC Press, Boca Raton, FL, 295p

*A good source, aimed at drillers and probably containing much more than you will ever need, this should answer all your technical questions about diamond drilling.*

Blackbourne GA (1990) Cores and core logging for geologists. Whittle's Publishing, Caithness, Scotland, 113p

*A Comprehensive coverage of drilling techniques from the geologists' point of view.*

Devereux S (1999) Drilling Techniques. Penwell, Tulsa, OK, 337p

Hartley JS (1994) Drilling: Tools and program management. AA Balkema, Rotterdam, 150p

*Good discussion of the management of drilling programmes and directional control of diamond drill holes.*

McPhie J, Doyle M, Allen R (1993) Volcanic textures. University of Tasmania, Hobart, TAS, 196p

*An example (p. 13) of graphical scale logging in volcanic rocks (and many other good and useful things besides).*

## Chapter 8

Drury SA (1990) A guide to remote sensing. Oxford University Press, London, 243p

*Detailed treatments of remote sensing technology.*

Drury SA (1993) Image interpretation in geology, 2nd edn. Chapman & Hall, London, 304p

*A superbly illustrated book on all aspects of image interpretation including aerial photography, satellite reflectance imagery and radar imagery. Now a bit dated but still relevant.*

Rencz AN (ed) (1999) Manual of remote sensing, 3rd edn. Wiley, New York, NY

Bedell R, Crosta AP, Grunsky E (2009) Remote sensing and spectral geology. Reviews in Economic Geology, vol 16. Society of Economic Geologists, Littleton, CO, 288p

*A series of invited review papers and up to date case studies on remote sensing applications in mineral exploration. Chapter 2 by Richard Bedell provides an excellent description of the principles behind spectral geology.*

## Chapter 9

Kosko B (1993) Fuzzy thinking – The new science of fuzzy logic. Hyperian Press, New York, NY, 318p

*A good introduction to fuzzy logic – entertainingly written.*

Kearney P, Brooks M (2002) Introduction to geophysical exploration, 3rd edn. Wiley, New York, NY, 272p

*An update of a classic textbook. Provides a separate chapter on each of the geophysical methods, with theory, field procedures and case histories. Minimal mathematics.*

Australian Geological Survey Organisation (1997) Special volume on Airborne magnetic and radiometric surveys. J Aust Geol Geophys 17(2)

*A number of review papers on the effective use of magnetic and radiometric data in mineral exploration.*

Handbook of exploration geochemistry, Elsevier, New York, NY

1. Fletcher WK (1981) Analytical methods in exploration geochemistry, 255p
2. Howarth RJ (ed) (1983) Statistics and data analysis in geochemical prospecting, 437p
3. Govett GJS (1983) Rock geochemistry in mineral exploration, 461 pp
4. Butt CRM, Zeegers H (1992) Regolith exploration geochemistry in tropical and subtropical terrains, 607p
5. Kauranne K, Salminen R, Eriksson K (eds) (1992) Regolith exploration geochemistry in arctic and temperate terrains, 443p

6. Hale M, Plant JA (1994) Drainage geochemistry, 766p  
*An exhaustive treatment of the theory and practice of mineral exploration geochemistry.*

Smith RE (1987) Using lateritic surfaces to advantage in mineral exploration. Proceedings of Exploration '87: Third Decennial International Conference on Geophysical and Geochemical Exploration for Minerals and Groundwater. Ontario Geological Survey, Special Volume, Toronto

*On using maps of the regolith to control geochemical mineral exploration.*

Butt CRM, Robertson KM, Cornelius M (2005) Regolith expressions of Australian ore systems. Cooperative Research Centre for Landscape Environment and Mineral Exploration (CRC LEME), Bentley, Western Australia, 423p

*A comprehensive collection of case histories of mineral discovery with emphasis on exploration models and use of regolith geochemistry. Full of good and relevant stuff, and not just for Australian explorers.*

## **Chapter 10**

Delaney J, Van Niel K (2009) Geographical Information Systems: An Introduction, 2nd edn. Oxford University Press, Oxford, 214p

*A good introductory text that is not based on any particular proprietary software.*

# Acronyms and Abbreviations

ALOS	Advanced land observation satellite
ASTER	Advanced space borne thermal emission and reflection radiometer
BLEG	Bulk leach extractable gold
BOH	Bottom of hole
CA	Core axis
CAD	Computer aided drafting
CCD	Charged couple device
CRC LEME	Cooperative research centre for landscape environment and mineral exploration
DDH	Diamond drill hole
DEM	Digital elevation model
DGPS	Differential global positioning system
EGNOS	European geostationary navigation overlay service
EM	Electromagnetic
GIS	Geographical information system
GPS	Global positioning system
g/t	Grams per tonne
HMC	Heavy mineral concentrate
IOCG	Iron oxide copper gold
IP	Induced polarisation
KISS	Keep it simple, stupid
KPI	Key performance indicator
LCA	Long core axis
LH	Left hand
MGA94	Map grid of Australia 94
MIP	Magnetic IP
MMR	Magnetometric resistivity
MSAS	Multifunctional satellite augmentation system
MSS	Multi spectral scanner
Mt	Million tonnes
ppm	Parts per million
ppt	Part per trillion
RAB	Rotary air blast

RC	Reverse circulation
RH	Right hand
RL	Relative level
SAM	Sub audio magnetics
SEDEX	Sedimentary exhalative
SEG	Society of Economic Geologists
SG	Specific gravity
SPOT	Satellite probatoire l'observation de la terre
SRTM	Shuttle radar tomography mission
SWIR	Short wave infra red
TIR	Thermal infra red
TM	Thematic mapper
TM	Transverse Mercator
TMI	Total magnetic intensity
TOH	Top of hole
USGS	United States Geological Survey
UTM	Universal transverse Mercator
VHR	Very high resolution
VMS	Volcanogenic massive sulphide
VNIR	Visible and near infra red
WAAS	Wide area augmentation system
WGS 84	World geodetic system 84



# DRILL HOLE No MP DDH 152

SHEET 4 OF 5

- Bedding
- └ Cleavage
- └ Foliation
- ~ Fault, Shear
- ⊕ Breccia
- ⊘ Broken core
- ▨ Disseminated
- Massive
- ▨ Pervasive ALTERATION
- ↖ Narrow vein
- \* Visible gold
- INCREASE ALTERATION

PROJECT :	MOUNT PORTER
PROSPECT :	10 400 NORTH
DATE :	11th. July 1992
LOGGED BY :	R.W. Marjori banks.

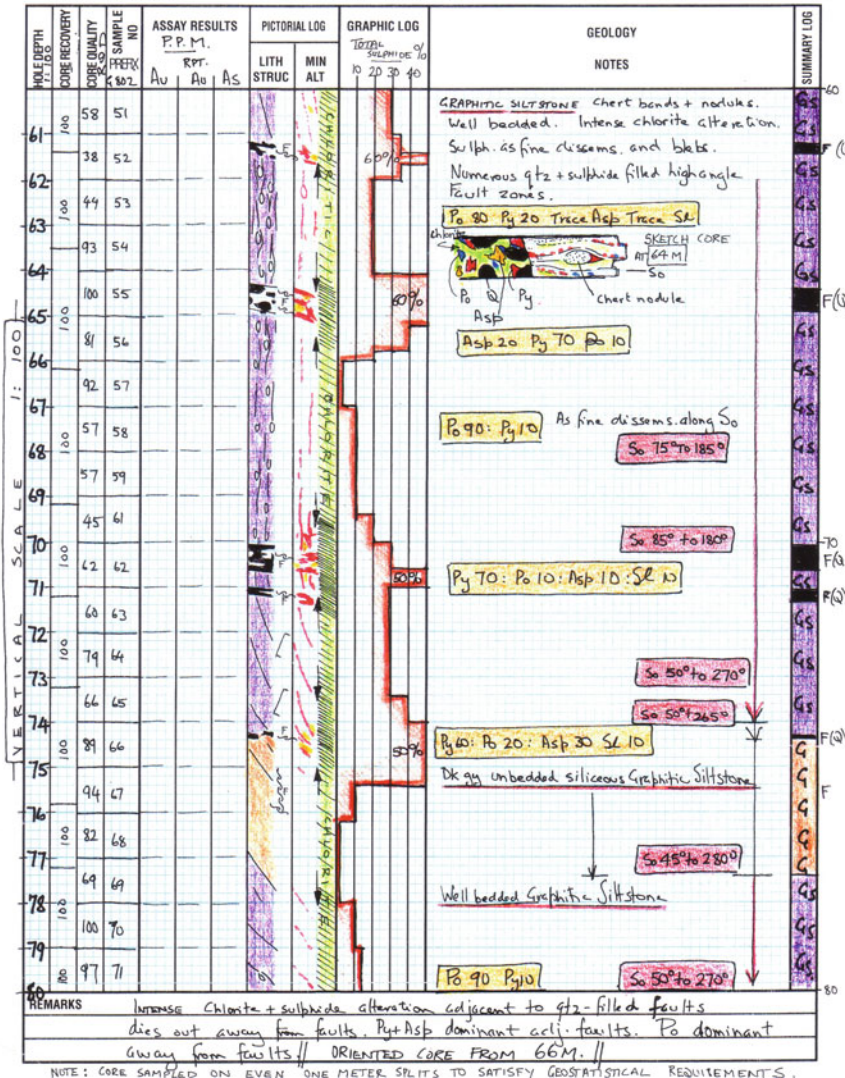

**Plate 1** An example of the use of graphical scale logging of core. Observations are recorded graphically and numerically on the log sheet against a selected down-page scale. The use of colour on such logs greatly enhances information content. Graphical logging is a powerful and flexible technique which supports detailed observation: its use is recommended for all first stage exploration drilling. A detailed description on this log form will be found in Appendix A (Refer Fig. 7.16)

# Index

## A

- Abitibi Province, 9
- Adit, 6, 65
- Air core drilling, *see* Drilling, rotary percussion
- Air photography, 18, 25
  - acquisition, 26
  - centre points, 34
  - collimation marks, 34
  - forward lap, 33–34
  - geological interpretation, 26–27
  - orthophoto, 37
  - orthophoto map, 37
  - orthorectification, 33, 37
  - overlays, 33
  - preparing prints, 37
  - resolution, 25
  - scale, 25, 27–29
  - scale distortion, 29–30
  - side lap, 29
  - stereoscopic viewing, 25, 29–31, 34
  - vertical exaggeration, 31
  - working with enlargements, 34–36
- Alidade
  - peepsight, 39
  - telescopic, 41
- Alpha angle, *see* Drilling, diamond
- Anaconda Copper Company, 51
- Anderson, E.M., 81
- Anomalous, 144–145
- Antiform, 112
- Apex Law, 51
- Apparent dip
  - calculating by formula, 202
  - calculating with a stereonet, 203
  - on drill sections, 202
  - estimating by table, 202
  - measuring with a nomogram, 203
  - on walls of open cuts, 56
  - on walls of underground openings, 60

- Assaying, 92
- Auger drilling, *see* Drilling, auger
- Azimuth, 88, 100, 103, 113, 123, 192, 199, 211

## B

- Backs, 56, 59
- Batter, 52, 55
- Berm, 52
- Beta angle, *see* Drilling, diamond
- Blind mineralisation, 3
- Boudins, 107, 196
- Bre-X Company, 128
- Brownfield exploration, *see* Exploration
- Brownfield, *see* Exploration
- Bucket auger, 96
- Busang scandal, 128
- Bushveld, 9
- Butte mine, 51

## C

- CAD (computer aided drafting software), 38
- Cannington Mine, 148
- Century Mine, 158
- Chamberlin, T.C., 15
- Chaos theory, 46
- Compass, 191
  - Brunton, 215, 220
  - card, 215
  - choosing, 215
  - Cocla, 218
  - damping, 215
  - Freiberg, 218, 220
  - magnetic declination, 215–216
  - magnetic field, 215
  - mapping on a pegged grid, 46
  - measuring strike and dip, 217
  - measuring structure in core, 193
  - measuring trend and plunge, 218–221
  - prismatic, 47

- quadrants, 22
- Silva, 215, 218
- Suunto, 47, 215
- Tectronic, 218
- use in open cut mines, 55
- use in tape and compass mapping, 47
- use in underground mines, 59–60
- use with plane table, 39
- Competing land use, 5
- Contouring, 175
- Contour trails, *see* Costeans
- Core frame, *see* Drilling, diamond
- Core orientation, *see* Drilling, diamond
- Costeans, 63
  - back-hoe, 64
  - bulldozer, 64
  - continuous trenching machines, 64
  - excavator, 64
  - geochemical sampling, 69–71
  - geological mapping, 66–68
  - hand digging, 64
  - pits and pitting, 6, 63
  - surveying, 66
  - trenches, 53, 63
  - trenching, 6
- Crandon Mine, 151
- D**
- Declination, *see* Compass
- Delta angle, *see* Drilling, diamond
- DEM (Digital Elevation Model), 37, 141, 174
- Deviation, 101, 123
- Dextral, 59, 82, 112, 190
- DGPS (differential global positioning system), 24, 146, 149, 154, 171
  - EGNOS, 24
  - MSAS, 24
  - WAAS, 24
- Diamond drilling, *see* Drilling, diamond
- Dilation zones, 81–82
- Dip, 22, 209, 211
  - measuring with a geologist's compass, 217
- Dip and dip direction, 22, 47
- DIPS, 200
- Down hole survey, *see* Drilling, diamond
- Drilling, auger, 75, 156
  - how it works, 96
  - sampling, 96
- Drilling, blast hole, 53
- Drilling, diamond
  - alpha angle, 105, 113, 115, 195–196, 209
  - assaying, 127, 180
  - beta angle, 195–196
  - BOH line, 132, 188–189, 192
  - BOH point, 188
  - choosing core diameter, 78
  - circumference plane, 195, 212
  - core axis, 101, 186, 195, 211
  - core barrel, 99
  - core diameters, 78
  - core frames, 192, 196, 201
  - core handling, 130
  - core lifter, 99
  - core orientation survey, 101
  - core protractors, 198
  - delta angle, 197, 213
  - down hole survey, 101, 113, 123–124
  - extension planes, 193
  - extension rods, 194
  - faults, appearance of, 105
  - folds, appearance of, 109
  - gamma angle, 197, 205
  - geological observation, 103
  - hand plotting section, 124
  - hole justification statement, 102, 179
  - how it works, 77, 96
  - inflection line, 195
  - inflection points, 105, 195, 200
  - internal core angles, 195
  - interpreting structures, 104
  - intersection ellipse, 104, 195, 201
  - lineations, appearance of, 83
  - logging, 116
    - analytical spread sheet, 119, 122, 167
    - geotechnical, 202
    - graphical, 117–118, 179
    - prose, 116
  - marking oriented core, 188
  - measuring bed thickness, 116
  - measuring specific gravity, 134
  - measuring structures, 113, 115
  - non-mechanical core orientation, 183
  - orientation by template, 186–187
  - orientation using a spear, 185
  - oriented core, 101, 127
  - oriented hole, 101
  - orienting by core barrel method, 187
  - planes, appearance of, 104
  - recording structures, 114
  - RQD (Rock Quality Designator), 130
  - sampling, 127, 129
  - setting up, 102–103
  - split tube barrel, 99
  - targeting, 80
  - vergence, 112–113
  - wire line, 99

- Drilling, rotary percussion, 77
  - air core, 79, 93
  - assaying, 92
  - bits, 85
  - blowback, 86
  - capping holes, 92–93
  - composite sampling, 95
  - cyclone, 85–86, 90
  - display and storage of cuttings, 88, 94
  - face sampling bit, 92
  - geological logging, 86, 94
  - how it works, 85, 93
  - logging, 86
  - pipe sampling, 95
  - RAB, 63, 76, 85, 93, 119
  - RC, 63, 77, 85, 119
  - sampling, 90, 92, 95
  - sampling below water table, 92
- Drill section, 100, 102
- Due diligence, 6
  
- E**
- Electrical surveys, *see* Geophysics
- Electromagnetic surveys, *see* Geophysics
- Empirical, *see* Exploration
- Environment, 64
  - advantage of diamond drilling, 79
  - capping holes, 93, 132
  - contour trails, 64
  - land use restrictions, 5
  - refilling trenches, 65
- Epigenetic, 81
- Ernest Henry Mine, 148
- Ertzberg Mine, 2
- Exploded box mapping, *see* Mapping
  - underground mines
- Exploration, 1
  - brownfield, 3
  - conceptual, 8–9
  - curve, 9
  - empirical, 8–9
  - failure, 7, 10
  - feasibility study, 6–7
  - feedbacks, 9–10
  - geo codes, 121
  - greenfield, 9
  - mature, 3, 143
  - play, 1, 7
  - resource evaluation, 6
  - resource evaluation drilling, 100
  - stages, 5–7
  - strategy, 9
  - target drilling, 6, 100
  - target generation, 5–6, 100
- Exploration data bases, 121, 165–166
  - geo codes, 121, 167
  - problems with, 167
  - validation, 170
- Explorationist, v
  
- F**
- Falsification of scientific theory, 17
- Fault movement vector, 82
- Feasibility study, *see* Exploration
- Feynman, R., 3
- Fieldranger, 20
- Field technician, 87
  - core handling, 130
  - handling oriented core, 188
  - use in measuring structure in core, 193
  - use in trenching, 69
  - use with plane table mapping, 40
- Flitch, 52
- Foot-in-ore, 10, 80
- Fractal dimension, 46, 111
- Fraud, 128
- Fuzzy logic, 144
  
- G**
- Gamma angle, *see* Drilling, diamond
- Geochemistry, 6, 47, 93, 96
  - BLEG, 158
  - channel sample, 69, 160
  - float, 64
  - HMC sampling, 158
  - laterite sampling, 161
  - mesh sizes, 155
  - panning, 156
  - pelican pick, 156, 158
  - rock chip sampling, 6, 160
  - sieves and sieving, 155
  - soil sampling, 6, 157
  - stream sediment sampling, 155
- Geo codes, *see* Exploration data bases
- Geologist's wobble, 46
- Geology
  - map, 13
  - section, 13
- Geophysics, 6
  - correction to pole, 147
  - electrical surveys, 151–152
  - electromagnetic surveys, 150–151
  - geological interpretation, 143–145, 154
  - gravity surveys, 149
  - ground magnetics, 146
  - image processing, 147

- induced polarisation (IP), 151
  - inversion modelling, 153
  - IP pseudo-sections, 152
  - magnetic surveys, 146
  - magnetometer, 146
  - MMR/MIP, 153
  - Naudy technique, 148–149
  - ore targeting, 144
  - radiometric ratios, 149
  - radiometric surveys, 150
  - reversal of magnetic polarity, 147
  - SAM (Sub Audio Magnetics), 153
  - spectrometer, 150
  - TMI (Total Magnetic Intensity), 146–147
  - upward continuation, 147
  - vertical derivatives, 147
  - Georeferencing, 33, 37, 140, 165, 171
    - cartesian coordinates, 20, 171
    - geographical coordinates, 171
    - geoid, 173
    - latitude & longitude, 23, 172
    - map datums, 172
    - MGA94, 172
    - registering maps, 173
    - satellite images, 140–141
    - transverse mercator projection, 173
    - UTM, 23, 25, 139, 171, 173
    - WGS84, 173
  - GIS (Geographical Information System), 145, 165–166, 173
    - digitised line format, 168
    - polygon or vector format, 170
    - raster format, 170
  - Google Earth, *see* Satellite images
  - Gortdrum Mine, 152
  - Gosowong Mine, 72
  - GPS (global positioning system), 23, 149
    - accuracy, 24
    - danger of relying on, 24
  - Graphical scale logging, *see* Drilling, diamond
  - Gravity surveys, *see* Geophysics
  - Greenfield exploration, *see* Exploration
  - Greenfield Mine, 71
  - Greenfield, *see* Exploration
  - Gridding, 18, 41
    - accuracy, 41
    - control for geological mapping, 44
    - coordinates, 43
    - ground markers, 43
    - slope corrections, 42
    - spacing of pegs, 41
    - surveyed base line, 41
  - Ground truth, *see* Maps
- H**
- Halmahera Island, 72
  - Hand augers, 96
  - Helicopter, 23, 27, 79, 146, 153
  - Hip-Chain, 20, 47
  - Hishikari Mine, 149
- I**
- Inclination, 80, 88, 100, 113, 116, 192, 199, 208
  - Induced Polarisation (IP), *see* Geophysics
  - Intellectual property, 5
  - Intelligent mapper, 17
  - Intelligent mapping, 15
  - Inversion modelling, *see* Geophysics
  - IOCG deposits, 140, 148
  - Ivanhoe Company, 3
- J**
- Jackhammer, 69, 160
- K**
- Kambalda, 2, 9, 104
  - Kencana Mine, 72
  - Key Performance Indicator (KPI), 75
  - Kidd Creek Mine, 151
  - KISS, *see* Occam's razor
  - Kriging, 168
- L**
- Ladolam Mine, 2
  - Lateral thinking, 2
  - Latitude & longitude, *see* Georeferencing
  - Lihir Island, 2
  - Lineations, 23, 109, 197, 213
    - how to measure, 213
  - Longyear Company, 99
  - Luck, 2
  - Lucky Draw Mine, 72
- M**
- Maghemite, 148
  - Magnetic north, *see* Compass, magnetic declination
  - Magnetic surveys, *see* Geophysics
  - Manto, 80
  - Mapping open cuts, 51
    - compiling to standard cross sections, 54
    - face map, 53
    - level plans, 18, 53
    - measuring strike and dip, 55
    - mine sections, 18
    - problems, 54
    - toe mapping, 53
  - Mapping styles, 16

- Mapping underground mines, 56
  - angular relationships, 59
  - choosing surface to map, 56
  - composite level plan, 59
  - exploded box mapping, 56
- Maps
  - bias, 14
  - fact, 14, 21
  - geological, 14–15
  - ground truth, 15
  - large scale, 14
  - outcrop, 14, 22
  - small scale, 14
  - topographic, 18
- McCluhan, M., 116
- Measuring dip, 55
- Measuring strike, 55
- Mercator, G., 172
- Merlin deposit, 3
- Modi Taung prospect, 72
- Moore's Law, 154
- Multiple working hypotheses, 15, 190
- Munsell colour charts, 94
  
- N**
- Newcrest Mining, 3
- Nomogram, 203
- Noranda Camp, 9
- Normal faults, 81
  
- O**
- Occam's razor, 10
  - KISS principle, 10
- Olympic Dam Mine, 148, 150
- Open cut mining, 51
- Optical square, 42
- Ore, definition, 1
- Oriented hole, *see* Drilling, diamond
- Orthogonal, 84
- Orthophoto, *see* Air photography
- Outcrop shapes, 42
- Oyu Tolgoi deposit, 2
  
- P**
- Pace length, measuring, 20
- Panguna Mine, 155
- Panning, *see* Geochemistry
- Pasteur, L., 112
- Peters, W.C., 103
- Photography
  - diamond drill core, 127
  - stereoscopic pairs, 31
- Pitch, 23, 81, 219
- Pits and pitting, *see* Costeans
  
- Placer deposits, 80, 81
- Plane table mapping, 20, 38
- Plunge, 23, 191, 194, 201
- Popper, K., 17
- Porgera Mine, 2
- Proffett, J., 13
- Project, 11
- Project fatigue, 7
- Prominent Hill Mine, 148, 150
- Prospect, 1
- Prospecting, 1
- Prospect wastage, 7
- Pumpelly, R., 17
- Pumpelly's Rule, 17, 111
  
- R**
- RAB drilling, *see* Drilling, rotary percussion
- Radar imagery, 14
- Radiometric surveys, *see* Geophysics
- RC drilling, *see* Drilling, rotary percussion
- Red Dog Mine, 2
- Reference rock suite, 55, 88
- Reflectance imagery, *see* Satellite images
- Regolith, 6, 17, 94, 143, 148, 150, 158, 161
- Resource evaluation drilling, *see* Exploration
- Reverse faults, 81, 83
- Ridgeway Mine, 3
- Riffle splitter, 69, 91–92
- Rock chip sampling, *see* Geochemistry
- Rock saw, 69, 156, 161
- Rollover of prospects, 8
- RQD, *see* Drilling, diamond
  
- S**
- Safety
  - in mines, 49
  - relying on GPS, 23
  - in trenches, 63, 65
- Sales Reno, 51
- SAM, *see* Geophysics
- San Nicolas deposit, 152
- Satellite images, 25, 31, 140
  - Aster, 142
  - electromagnetic reflectance, 143
  - electromagnetic wavelengths, 139
  - false colour composite, 140
  - GeoEye, 141
  - geological interpretation, 26
  - georeferencing, 137, 140
  - GoogleEarth, 141
  - how they are acquired, 141
  - Ikonos, 141
  - Landsat, 141
  - multispectral bands, 139

- ortho rectification, 37, 141
- overlays, 31
- panchromatic, 139
- pan-sharpening, 140
- pixel, 139
- preparing prints for the field, 31
- Quickbird, 141
- reflectance imagery, 25
- reflectance signature, 100
- resolution, 137
- scales, 137, 140
- spectral geology, 137
- Spot, 140
- SRTM, 140
- stereoscopic viewing, 29–30, 140
- SWIR, 98, 142
- Thematic Mapper, 142
- VHR, 140–141
- WorldView, 141
- Scale
  - air photo, 24, 26
  - choosing the best, 18
  - distortion on air photographs, 28
  - intermediate, 21
  - invariance, 17
  - large, 13, 21
  - mapping costeans and trenches, 63
  - mapping open cut mines, 51
  - mapping underground mines, 56
  - satellite images, 137, 140
  - small, 13, 14, 20
- Scale problem in core, 110–112
- Scientific method, 15
- Section, 13
- SEDEX deposits, 81
- Sieves and sieving, *see* Geochemistry
- Sillitoe, R., 2
- Sinistral, 59, 82, 112, 190
- Sluicing, 63
- Soil sampling, *see* Geochemistry
- Spectral geology, *see* Satellite images
- Stacked sections, 174
- Stadia, 41
- Stereonet, 195, 200, 203
  - calculating apparent dip, 181
  - crunching alpha and beta, 213
  - crunching gamma and delta, 211
  - 3 non-parallel holes problem, 208
  - pole to the plane, 209, 214
  - solving the 3-point problem, 1205
- Stereoscope, 166
  - mirror, 31
  - mounting frame, 31
  - pocket, 27, 31
- Stereoscopic viewing, *see* Air photography
- Strategy, *see* Exploration
- Stream sediment sampling, *see* Geochemistry
- Strike, 46, 181, 201, 203
  - importance of, 22
  - measuring with a geologist's compass, 215
  - measuring in trenches, 63
  - right hand rule, 22
- Strike-slip faults, 81, 82
- Structure contours, 205–206
- Sukari Mine, 2
- Supergene, 80
- Synform, 112
- Syngenetic, 81
- T**
- Tape and compass mapping, 20, 47, 53
  - slope corrections, 47
- Target drilling, *see* Exploration
- Tenement, 1
- Thematic Mapper, *see* Satellite images
- Theodolite, 39, 42
- Three point problem, 116, 205
- Thrust faults, 81, 82
- Toe, 53
- Toguraci Mine, 72
- Topofil, 20
- Trenches, *see* Costeans
- Trend, 23, 176, 208, 213
- Triangulation, 40–41, 46, 176
  - Delauney triangulation, 176
- Tributing, 65
- True north, *see* Compass, magnetic declination
- U**
- Underground development, 6, 59, 64–65, 69
- UTM (Universal transverse Mercator), *see* Georeferencing
- V**
- Vergence, *see* Drilling, diamond
- Voisey Bay Mine, 2
- W**
- Woodall, R., 104
- Y**
- Yilgarn Province, 79, 105