

**ACI 376-11**

**Code Requirements for Design  
and Construction of Concrete  
Structures for the Containment of  
Refrigerated Liquefied Gases and  
Commentary**

An ACI Standard

Reported by ACI Committee 376



**American Concrete Institute®**



First Printing  
May 2013

**American Concrete Institute®**  
*Advancing concrete knowledge*

## **Code Requirements for Design and Construction of Concrete Structures for the Containment of Refrigerated Liquefied Gases and Commentary**

Copyright by the American Concrete Institute, Farmington Hills, MI. All rights reserved. This material may not be reproduced or copied, in whole or part, in any printed, mechanical, electronic, film, or other distribution and storage media, without the written consent of ACI.

The technical committees responsible for ACI committee reports and standards strive to avoid ambiguities, omissions, and errors in these documents. In spite of these efforts, the users of ACI documents occasionally find information or requirements that may be subject to more than one interpretation or may be incomplete or incorrect. Users who have suggestions for the improvement of ACI documents are requested to contact ACI via the errata website at [www.concrete.org/committees/errata.asp](http://www.concrete.org/committees/errata.asp). Proper use of this document includes periodically checking for errata for the most up-to-date revisions.

ACI committee documents are intended for the use of individuals who are competent to evaluate the significance and limitations of its content and recommendations and who will accept responsibility for the application of the material it contains. Individuals who use this publication in any way assume all risk and accept total responsibility for the application and use of this information.

All information in this publication is provided “as is” without warranty of any kind, either express or implied, including but not limited to, the implied warranties of merchantability, fitness for a particular purpose or non-infringement.

ACI and its members disclaim liability for damages of any kind, including any special, indirect, incidental, or consequential damages, including without limitation, lost revenues or lost profits, which may result from the use of this publication.

It is the responsibility of the user of this document to establish health and safety practices appropriate to the specific circumstances involved with its use. ACI does not make any representations with regard to health and safety issues and the use of this document. The user must determine the applicability of all regulatory limitations before applying the document and must comply with all applicable laws and regulations, including but not limited to, United States Occupational Safety and Health Administration (OSHA) health and safety standards.

Participation by governmental representatives in the work of the American Concrete Institute and in the development of Institute standards does not constitute governmental endorsement of ACI or the standards that it develops.

Order information: ACI documents are available in print, by download, on CD-ROM, through electronic subscription, or reprint and may be obtained by contacting ACI.

Most ACI standards and committee reports are gathered together in the annually revised ACI Manual of Concrete Practice (MCP).

**American Concrete Institute**  
**38800 Country Club Drive**  
**Farmington Hills, MI 48331**  
**U.S.A.**  
**Phone: 248-848-3700**  
**Fax: 248-848-3701**

**[www.concrete.org](http://www.concrete.org)**

ISBN-13: 978-0-87031-814-6  
ISBN: 0-87031-814-4

# Code Requirements for Design and Construction of Concrete Structures for the Containment of Refrigerated Liquefied Gases (ACI 376-11) and Commentary

An ACI Standard

Reported by ACI Committee 376

Neven Krstulovic-Opara, Chair

Piotr D. Moncarz, Secretary

Junius Allen	George C. Hoff	Praveen K. Malhotra	Eric S. Thompson
Dale Berner	Richard A. Hoffmann	Keith A. Mash	Sheng-Chi Wu
Mike S. Brannan	John Holleyoak	Stephen Meier	<i>Consulting members</i>
Hamish Douglas	Joseph Hoptay	Robert W. Nussmeier	Robert Arvedlund
Charles S. Hanskat	Thomas R. Howe	Rolf P. Pawski	James P. Lewis
Humayun Hashmi	Dajiu Jiang	Ramanujam S. Rajan	Terry Turpin
Alan D. Hatfield	Jameel U. Khalifa	William E. Rushing Jr.	
Kare Hjortset	Nicholas A. Legatos	Robert W. Sward	

Note: Special acknowledgment to Jeffrey Garrison for his contributions to this document.

**Keywords:** bund wall; commissioning; cryogenic; damage stability; decommissioning; earthquake design levels; fatigue; float out; floating storage unit; foundation heating; gravity base structure; impact loads; liners; liquefied natural gas; liquid stratification; permanent ballast; purging; refrigerated liquefied gas; reinforcement (cryogenic); tanks; thermal corner protection.

## CONTENTS

<b>INTRODUCTION</b> . . . . .	<b>3</b>
<b>CHAPTER 1—GENERAL</b> . . . . .	<b>5</b>
1.1—Scope . . . . .	5
1.2—Quality assurance . . . . .	6

<b>CHAPTER 2—NOTATION AND DEFINITIONS</b> . . . . .	<b>7</b>
2.1—Notation . . . . .	7
2.2—Definitions . . . . .	8
<b>CHAPTER 3—REFERENCED STANDARDS</b> . . . . .	<b>14</b>
<b>CHAPTER 4—MATERIALS</b> . . . . .	<b>18</b>
4.1—Testing of materials . . . . .	18
4.2—Cementitious materials . . . . .	18
4.3—Aggregates . . . . .	18
4.4—Water . . . . .	19
4.5—Admixtures . . . . .	19
4.6—Fibers . . . . .	19
4.7—Deformed reinforcement . . . . .	19
4.8—Plate steel composite with concrete . . . . .	20
4.9—Prestressed reinforcement . . . . .	21
4.10—Prestressing anchorages . . . . .	21
4.11—Post-tensioning ducts . . . . .	22
4.12—Grout . . . . .	22
4.13—Metal liners and nonstructural metal components . . . . .	22
4.14—Insulation . . . . .	23
4.15—Coating requirements . . . . .	23

ACI Committee Reports, Guides, and Commentaries are intended for guidance in planning, designing, executing, and inspecting construction. This document is intended for the use of individuals who are competent to evaluate the significance and limitations of its content and recommendations and who will accept responsibility for the application of the material it contains. The American Concrete Institute disclaims any and all responsibility for the stated principles. The Institute shall not be liable for any loss or damage arising therefrom.

Reference to this document shall not be made in contract documents. If items found in this document are desired by the Architect/Engineer to be a part of the contract documents, they shall be restated in mandatory language for incorporation by the Architect/Engineer.

ACI 376-11 was adopted November 11, 2011, and was published May 2013.

Copyright © 2013, American Concrete Institute.

All rights reserved including rights of reproduction and use in any form or by any means, including the making of copies by any photo process, or by electronic or mechanical device, printed, written, or oral, or recording for sound or visual reproduction or for use in any knowledge or retrieval system or device, unless permission in writing is obtained from the copyright proprietors.

**CHAPTER 5—DESIGN LOADS . . . . . 24**

- 5.1—Design loads . . . . . 24
- 5.2—Loading conditions . . . . . 28

**CHAPTER 6—MINIMUM PERFORMANCE REQUIREMENTS . . . . . 31**

- 6.1—General . . . . . 31
- 6.2—Primary concrete container . . . . . 31
- 6.3—Secondary concrete container . . . . . 34
- 6.4—Roof performance criteria . . . . . 35
- 6.5—Other performance criteria . . . . . 35
- 6.6—Concrete quality . . . . . 36
- 6.7—Shotcrete . . . . . 40
- 6.8—Coating design . . . . . 40
- 6.9—Metal components . . . . . 41

**CHAPTER 7—LOAD FACTORS . . . . . 42**

- 7.1—General . . . . . 42
- 7.2—Load factors for ultimate limit state of primary container . . . . . 42
- 7.3—Load factors for ultimate limit state of secondary container . . . . . 45

**CHAPTER 8—ANALYSIS AND DESIGN . . . . . 49**

- 8.1—Methods of analysis . . . . . 49
- 8.2—Design basis . . . . . 54
- 8.3—Foundation design . . . . . 54
- 8.4—Wall design . . . . . 55
- 8.5—Roof design . . . . . 58

**CHAPTER 9—DETAILING . . . . . 60**

- 9.1—General . . . . . 60
- 9.2—Reinforcement details . . . . . 60
- 9.3—Internal prestressing systems . . . . . 61
- 9.4—External prestressing systems . . . . . 63
- 9.5—Concrete containment wall . . . . . 63
- 9.6—Metal components . . . . . 65
- 9.7—Anchorage to concrete . . . . . 66
- 9.8—Liners and coatings . . . . . 67

**CHAPTER 10—FOUNDATIONS . . . . . 69**

- 10.1—General . . . . . 69
- 10.2—Geotechnical investigation . . . . . 69
- 10.3—Design requirements for shallow foundations . . . . . 72
- 10.4—Design requirements for deep foundations . . . . . 76
- 10.5—Ground improvement . . . . . 80
- 10.6—Foundation details . . . . . 80
- 10.7—Foundation performance monitoring details . . . . . 82
- 10.8—Monitoring frequency . . . . . 84
- 10.9—Inspection and testing . . . . . 85

**CHAPTER 11—CONSTRUCTION REQUIREMENTS . . . . . 87**

- 11.1—Construction plan . . . . . 87
- 11.2—Tolerances . . . . . 87

- 11.3—Shotcrete for external prestressing systems . . . . . 90
- 11.4—Post-tensioning . . . . . 91
- 11.5—Winding of prestressed reinforcement: wire or strand . . . . . 95
- 11.6—Forming . . . . . 95
- 11.7—Construction joints . . . . . 97
- 11.8—Concrete embedments . . . . . 97
- 11.9—Coatings . . . . . 98
- 11.10—Welding . . . . . 98

**CHAPTER 12—COMMISSIONING/ DECOMMISSIONING . . . . . 99**

- 12.1—Scope . . . . . 99
- 12.2—Testing . . . . . 99
- 12.3—Pressure and vacuum testing . . . . . 104
- 12.4—Purging into service . . . . . 105
- 12.5—Cool-down . . . . . 106
- 12.6—Settlement and movement monitoring . . . . . 108
- 12.7—Liquefied natural gas tank fill methods . . . . . 109
- 12.8—Decommissioning: purging out of service and warm-up . . . . . 109
- 12.9—Recordkeeping . . . . . 111
- 12.10—Nameplate . . . . . 111

**APPENDIX A—TANK CONFIGURATIONS, DETAILS, AND EXAMPLES . . . . . 113**

- RA.1—Tank configurations . . . . . 113
- RA.2—Full-containment tanks: typical details . . . . . 113
- RA.3—Examples of base joint details . . . . . 113

**APPENDIX B—OFFSHORE CONCRETE TERMINALS . . . . . 124**

- B.1—Scope . . . . . 124
- B.2—General . . . . . 124
- B.3—Loads and load combinations . . . . . 125
- B.4—Concrete and reinforcement materials . . . . . 128
- B.5—Global and local structural analysis . . . . . 129
- B.6—Criteria and methodology of concrete sectional design . . . . . 131
- B.7—Fatigue performance criteria . . . . . 132
- B.8—Design considerations during construction, transportation, and installation . . . . . 132
- B.9—Decommissioning . . . . . 135
- B.10—Design for accidents . . . . . 135

**APPENDIX C—FATIGUE PERFORMANCE . . . . . 139**

- C.1—Scope . . . . . 139
- C.2—General . . . . . 139
- C.3—Fatigue performance criteria . . . . . 139

**COMMENTARY REFERENCES . . . . . 142**

## INTRODUCTION

ACI Committee 376 was formed and subsequently ACI 376-11 was drafted in response to a request from the National Fire Protection Association (NFPA) Technical Committee 59A on liquefied natural gas (LNG). That committee is responsible for NFPA 59A, which is an internationally recognized standard governing the production, storage, and handling of LNG at an operating temperature of  $-270^{\circ}\text{F}$ .

NFPA 59A contains provisions for the use of reinforced concrete and prestressed concrete for two principal applications: 1) impoundment—secondary containment in conjunction with a metallic primary container; and 2) storage—primary containment. NFPA 59A is somewhat limited; it does not provide guidelines specifically tailored to concrete use at cryogenic temperatures. This limitation was the impetus for Committee 59A's request. Although the request was related specifically to containment of LNG, this code addresses concrete use for other refrigerated liquefied gas (RLG) as well, ranging in operating temperatures from  $+40$  to  $-325^{\circ}\text{F}$ . This makes the code and commentary analogous to the American Petroleum Institute's API 620, which governs design and construction of steel and aluminum RLG storage tanks to  $-270^{\circ}\text{F}$ .

The most common use of reinforced concrete and prestressed concrete in cryogenic storage applications is for secondary containment around metal primary storage tanks. Prestressed concrete primary containment tanks were built in North America and Europe from the 1960s through the 1980s. Renewed interest in the use of concrete for primary containment and the need for a code that addressed secondary concrete containment led to the development of this code, which includes pertinent excerpts from ACI 318-11 and ACI 350-06. The commentary includes considerations by the committee in developing the code.

The commentary is not intended to provide a complete historical background concerning development of the code, nor is it intended to provide a detailed summary of the studies and research data reviewed by the committee in formulating its provisions. References to specific research

data are provided for more in-depth study of the background materials.

ACI 376 may be used as a part of a legally adopted code and, as such, must differ in form and substance from documents that provide detailed specifications, recommended practice, complete design procedures, or design aids.

Requirements more stringent than the code provisions are desirable for unusual structures. This code and commentary cannot replace sound engineering knowledge, experience, and judgment. A code for design and construction states the minimum requirements necessary to provide for public health and safety. ACI 376 is based on this principle. For any structure, the owner and engineer may require the quality of materials and construction to be higher than the minimum requirements necessary to provide serviceability and to protect the public as stated in the code. Lower standards, however, are not permitted.

ACI 376 has no legal status unless it is adopted by regulatory bodies. Where the code has not been adopted, it may serve as a reference to good practice. The code provides a means of establishing minimum standards for acceptance of design and construction by a legally appointed official or designated representative. The code and commentary are not intended for use in settling disputes between the owner, engineer, contractor, or their agents, subcontractors, material suppliers, or testing agencies. Therefore, the code cannot define the contract responsibility of each of the parties in typical construction. General references requiring compliance with ACI 376 in the job specifications should be avoided because the contractor is rarely in a position to accept responsibility for design details or construction requirements that depend on a detailed knowledge of the design. Generally, the contract documents should contain all of the necessary requirements to ensure compliance with the code. In part, this can be accomplished by reference to specific code sections in the job specifications. Other ACI publications, such as ACI 301, are written specifically for use as contract documents for construction.



**CODE****COMMENTARY****CHAPTER 1—GENERAL****1.1—Scope**

This code provides minimum requirements for design and construction of reinforced concrete and prestressed concrete structures for the storage and containment of refrigerated liquefied gases (RLG) with service temperatures between +40 and -325°F. Notwithstanding, the principals listed herein are applicable to concrete foundations of double-steel tanks subject to the approval of the owner.

Container design shall include the design of the container wall, its foundation (footing and floor slab), the concrete portions of its roof, and the bund wall, whenever applicable.

**R1.1—Scope**

Typically, reinforced concrete and prestressed concrete structures for the containment of RLGs are classified into two main categories:

- a) Secondary containment, which represents the most widespread use of such structures
- b) Primary containment

Henceforth in this document, the term “concrete” is used to denote both conventionally reinforced and prestressed concrete. This code is not applicable to the design of membrane tanks because construction and detailing requirements are not included. A membrane tank has a non-self-supporting thin layer (membrane) inner tank that is supported through insulation by an outer tank. With appropriate additional engineering analysis and justification, portions of this code may be applied to the design of a concrete outer tank of a membrane tank using both primary and secondary tank criteria. This code does not address the materials, design, or construction of steel primary or secondary tanks. Such information is further described in API 620.

This code has been developed with the lowest operating temperature of -325°F. Lower product temperatures could also be used, however, provided appropriate additional engineering analysis and justification is performed for each proposed application. Single containment, double containment, and full containment concepts are covered by this code.

A concrete bund wall is an open-top cylindrical wall serving as the outer boundary of an impounding area surrounding a single-containment RLG storage tank.

In a double-containment tank system, the primary container is normally a single-containment RLG storage tank with a vapor-tight shell and roof designed to contain both refrigerated liquid and the associated vapors under normal operating conditions. In this system, the secondary container is often an open-top concrete wall that serves two basic functions:

- a) Provides protection to the primary container from external loads under normal operating conditions
- b) Contains the leakage from the primary container (but not the vapor generated from such leakage) under accidental-spill conditions

In a full-containment tank system, the primary container is designed to contain the refrigerated liquid under normal operating conditions. In this system, the secondary container is a vapor-tight wall with a vapor-tight roof that spans over the inner tank. The roof may be metal, concrete, or a composite of the two materials.

Under normal operating conditions, the secondary container provides protection to the primary container from external loads. Under accidental-spill conditions, the secondary container also contains the leakage from the primary container and contains or controls the vapor generated from such leakage.

## CODE

## COMMENTARY

**1.2—Quality assurance**

**1.2.1 Plan**—The project specifications shall include provisions for developing a quality assurance plan to verify that materials, fabrication, and construction conform to the design. The plan shall include:

1. Procedures for exercising control of fabrication and construction;
2. Required inspections and tests; and
3. Inspection and test procedures.

**1.2.2 Traceability**—The location of all permanent materials in the structure shall be traceable to source documents demonstrating compliance with specifications, standards, tests, and quality assurance and quality control requirements. The quality assurance/quality control system documents shall identify which component or material in the structure was tested or certified.

**1.2.3 Documentation**

**1.2.3.1** Documentation of materials, testing, and performance measurements and results shall be provided in a quality assurance/quality control system specified in the project specifications.

**1.2.3.2** The quality assurance/quality control system documents shall be adequately detailed to identify precisely which component or material in the structure was tested. Records of all test results shall be preserved and disposition of failed materials documented.

**1.2.3.3** Documentation of all materials, testing, and performance measurements and results shall be available at all times during construction.

Only material selection criteria are included for the thermal corner protection (TCP) of a secondary tank in this code. The design parameters, analysis methods, acceptance criteria (stress or strain limits), and detailing and construction requirements for TCP are excluded from this code.

**R1.2—Quality assurance**

**R1.2.1** For the design-build approach typically used for RLG tank construction, the project specifications will provide only an outline of the quality assurance requirements. The design-build contractor is typically responsible for developing details of the quality assurance plan and quality control.

**R1.2.2** Source documents should include:

1. Mill certificates demonstrating conformity with ASTM or other applicable standards for metal and concrete and grout components;
2. Certification of conformance to standards and specifications from material suppliers;
3. Truck batch tickets for ready mixed concrete, and results of field and laboratory tests for concrete and grout placed at the site;
4. Weld procedure specifications used for welding of reinforcement, plate, and structural steel; and
5. Qualifications of welders, shotcrete nozzlemen, and inspectors or other personnel performing tests and inspections.

**R1.2.3.1** All certifications, quality assurance/quality control records, design drawings, specifications, and construction records of any kind should be assembled by the owner in a logical manner that facilitates later recovery and review. All documentation should be furnished in paper and electronic formats. The owner should maintain these documents through the life of the tank.



## CODE

## COMMENTARY

## CHAPTER 2—NOTATION AND DEFINITIONS

## 2.1—Notation

- $B$  = blast (Chapters 5, 7)  
 $c$  = specific heat (Chapter 6)  
 $C$  = experimentally determined fatigue coefficient (Appendix C)  
 $C$  = penetration coefficient (Chapter 8)  
 $D$  = tank diameter (Chapter 10)  
 $D$  = dead loads, or related internal moments and forces (Chapters 5, 7)  
 $D_p$  = projectile diameter (Chapter 8)  
 $E$  = environmental load (Chapter 7)  
 $E_c$  = modulus of elasticity of concrete (Chapters 2, 6)  
 $E_o$  = operating basis earthquake (Chapters 2-8, 10, Appendix B)  
 $E_S$  = safe shutdown earthquake product (service) (Chapter 5)  
 $f_c$  = specified compressive strength of concrete (Chapters 6, 8, Appendix C)  
 $f_{cr}$  = specified compressive strength of concrete at time of initial prestress (Chapters 2, 5-8, 10, Appendix B)  
 $F$  = loads due to weight and pressure of fluids with well-defined densities and controllable maximum heights, or related internal moments and forces (Chapters 5, 7)  
 $F_s$  = foundation settlement (Chapter 5)  
 $F_t$  = maximum hydrostatic load due to test water (Chapter 5)  
 $F_v$  = vertical earth pressure (Chapter 5)  
 $g$  = gravitational constant  
 $h_d$  = minimum dome thickness to resist buckling (Chapter 6, 8)  
 $H$  = heat radiation from adjacent fire  
 $k$  = different stress magnitudes in a spectrum,  $S_i$  ( $1 < i < k$ ) (Appendix C)  
 $k$  = intrinsic coefficient of permeability (Chapter 5-7)  
 $K$  = coefficient of hydraulic conductivity (Chapter 6)  
 $L$  = live load (primarily snow; also: temporary equipment, roof live load) (Chapters 5, 7)  
 $L_{cm}$  = live load effects resulting from commissioning activities (Chapter 7)  
 $L_{cn}$  = live load effects resulting from construction activities (Chapter 7)  
 $m_p$  = projectile mass, lb (Chapter 8)  
 $M_i$  = missile impact (Chapters 5, 7)  
 $n(S_i)$  = contributing stress cycle  
 $N_i(S_i)$  = number of cycles to failure of a constant stress reversal,  $S_i$  (Appendix C)  
 $P_d$  = internal pressure (service) (Chapter 5)  
 $P_e$  = accidental internal overpressure (applies to full-containment outer wall and domed roof) (Chapter 5)  
 $P_f$  = final prestressing (at service load) (Chapters 5, 7)  
 $P_i$  = initial prestressing (at transfer) (Chapters 5, 7)  
 $P_t$  = internal pressure (test) (Chapter 5)

## CODE

## COMMENTARY

$P_u$	= factored axial force; to be taken as positive for compression and negative for tension (Chapter 8)
$P_v$	= accidental vacuum pressure (applies to full-containment outer wall only) (Chapter 5)
$r$	= tank radius (Chapter 11)
$r_d$	= nominal radius of curvature of dome (Chapter 11)
$r_{imp}$	= average radius of curvature of dome in an imperfection region (Chapter 5, 8)
$R$	= roof loads (appurtenances and suspended ceiling) (Chapter 5)
$R$	= force reduction factor (Chapter 8)
$R$	= earthquake response component (Appendix B)
$S_i$	= constant stress reversal (Appendix C)
$T$	= cumulative effect of temperature, creep, shrinkage, and differential settlement (Chapters 5, 7)
$T_c$	= loads associated with the creep of concrete (Chapter 7)
$T_{ds}$	= loads associated with differential settlement (Chapter 7)
$T_e$	= temperature and temperature differential due to sudden cooling (Chapters 5, 7)
$T_o$	= temperature and temperature differential at service loads (Chapter 5)
$T_o$	= internal moments and forces caused by temperature and moisture distributions within concrete structure as a result of commissioning, normal operating, or decommissioning conditions (Chapter 7)
$T_s$	= loads associated with shrinkage of concrete (Chapter 7)
$v$	= projectile speed (Chapter 8)
$w$	= concrete density (Chapter 8)
$W$	= wind (Chapters 5, 7)
$q_u$	= ultimate bearing capacity (Chapter 10)
$Q_a$	= pile safe design load (Chapters 2, 10)
$Q_r$	= ultimate capacity of single piles (Chapter 10)
$\beta_c$	= buckling strength reduction factor due to creep, material nonlinearity, and cracking of concrete (Chapter 8)
$\beta_{imp}$	= buckling strength reduction factor due to imperfections (Chapter 8)
$\phi$	= strength reduction factor (Chapters 7, 8)
$\mu$	= Poisson's ratio, or dynamic viscosity of fluid (Chapter 6)
$\rho$	= density of fluid (Chapter 6)

**2.2—Definitions**

For consistent application of this code, it is necessary that terms be defined where they have particular meanings in this code. The definitions given are for use in application of this code only and do not always correspond to ordinary usage. A glossary of most-used terms relating to cement manufacturing, concrete design and construction, and research in concrete is contained in "Concrete Terminology," available on the ACI Web site.

**abnormal load**—load that arises from an uncontrolled or unplanned situation with safety or environmental consequences.

## CODE

## COMMENTARY

**accidental load**—load that arises from accidental conditions such as dropped objects, fire, explosion, boat/vessel impact, thermal shock, mooring failure, and loss of pressure or buoyancy when floating.

**allowable pile service load**—pile safe design load  $Q_a$ ; load at which the factor of safety with respect to a downward plunging or sinking of a single pile has a value consistent with the customary safety requirements.

**allowable stress**—maximum permissible stress used in the design of members of a structure and based on a factor of safety against rupture or yielding.

**anchorage**—(1) a device used to maintain elongation in prestressing strand or bar by transferring compression load to concrete; or (2) a device embedded in concrete for the purpose of providing a connection to another member or structure.

**anchorage zone (zone, anchorage)**—(1) the region of a post-tensioned member adjacent to the anchorage and subjected to secondary stresses resulting from the distribution of the prestressing force; or (2) the region over which bond stresses transfer pretensioning load into a concrete member.

**appurtenance**—equipment or structural components attached to the containment system.

**boil-off**—process of vaporization of refrigerated liquid by heat conducted through the insulation surrounding the storage tank.

**benchmark**—a defined, recoverable survey reference point whose terrestrial position is precisely known horizontally and vertically.

**boat/vessel impact**—refers to loading from a supply boat, tug, or refrigerated liquefied gas (RLG) vessel berths to boat landing structure, fender, or RLG berthing platform.

**boring**—a hole drilled into the ground, usually vertical, to collect soil samples and to investigate soil properties.

**bund wall**—a wall forming the perimeter of an impounding space and preventing accidental release of liquid into unintended spaces.

**calculated crack width**—crack width calculated using a concrete constitutive model.

**commissioning**—the start-up processes, such as purging and cool-down.

**compressibility (soil)**—the measure of the volume change in a soil in response to a pressure or mean stress change.

**container**—a vessel for storing refrigerated liquefied gas.

**containment**—holding liquid or vapor in a defined space in a controlled manner.

**containment, full**—a containment system comprised of a primary container that directly contains the liquid product, surrounded by a secondary container that contains vaporous product during normal operation and, in the event of primary container leakage, contains leaked liquid product and ensures controlled vapor containment or venting.

**containment, primary**—part of a single, double, or full containment or full containment that contains the liquid during normal operation.

## CODE

## COMMENTARY

**containment, secondary**—the outer container of a double or full containment tank that contains the liquid in the event of leakage of the primary containment. For full-containment tanks, the outer container also contains the vapor in normal operation and ensures controlled venting of the vapor in the event of primary container leakage.

**containment, single**—a containment system comprised of a single-wall container designed to contain both RLG and product vapor, or a double-wall container where only the primary container is designed to contain RLG.

**cool-down**—planned and controlled cooling of the tank.

**cryogenic**—being or related to very low temperatures down to  $-325^{\circ}\text{F}$  in the production, storage, and handling of refrigerated liquefied gas.

**cryogenic reinforcement**—concrete reinforcing materials that respond in a ductile mode at specified cryogenic temperatures and service conditions.

**damage stability**—a design feature that allows a floating gravity base structure or floating hull to maintain its floating stability after its outer surface has been penetrated.

**decommissioning**—the process of the purging and warm-up of the tank so it can be taken out of service.

**deformed reinforcement**—metal bars, wire, or fabric with a manufactured pattern of surface ridges that provide a locking anchorage with surrounding concrete.

**design pressure**—the pressure used in the design of equipment, a container, or a vessel for the purpose of determining the minimum allowable thickness or physical characteristics of its parts; where applicable, static head is included in the design pressure to determine the thickness of any specific part.

**design strength**—nominal strength of a member multiplied by a strength reduction factor  $\phi$ .

**development length**—the bonded length required to transfer the design strength of a reinforcement at a critical section.

**down-drag**—vertical load on piles, pile groups, piers, or other foundation elements caused by friction force resulting from ongoing consolidation of surrounding soil.

**dropped objects**—an accidental load condition resulting from the impact energy of large objects falling or dropped on the concrete surfaces of the structure. Such objects can include, but are not limited to, loading/offloading arms, cranes, compressors, drill pipe, and risers.

**ductility level earthquake (DLE)**—maximum level earthquake a structure is expected to withstand without collapsing, with the return period as defined by the owner. The term is used in the offshore structure industry.

**effective depth of section**—depth of a beam or slab section measured from the compression face to the centroid of the tensile reinforcement.

**embedment length**—the length of embedded reinforcement provided beyond a critical section.

**fill or soil surcharge**—vertical load applied to finished grade above a foundation or adjacent to a retaining wall.

**float out**—construction phase where a hull is floated from the dry dock to its final destination.

## CODE

## COMMENTARY

**floating storage and regasification units**—a permanently moored, floating hull for the purposes of storage and regasification of refrigerated liquefied gas.

**floating storage units**—a permanently moored, floating hull for the purpose of storing refrigerated liquefied gas.

**freeboard**—the vertical distance from the specified maximum product level to the top of the liquid containment wall of a tank.

**global analysis**—analysis of the overall storage system that includes both the structure and structural support conditions.

**gravity base structure**—structure that rests on the ocean floor and resists sliding and overturning from environmental loads solely by the weight of the structure, equipment, and stored product.

**inclinometer**—an instrument for measuring angles of slope, tilt, or inclination of an object with respect to gravity.

**intrinsic permeability**—the portion of hydraulic conductivity defined by the properties of the porous medium alone.

**lateral load resistance (pile)**—the capacity of a pile to resist lateral load.

**liner**—metallic or other barrier systems on either side of a primary or secondary containment structure impervious to liquid, product vapor, and water vapor.

**liquefied gas**—a substance that exists in a gaseous state at standard pressure and temperature (a temperature of 60°F and a pressure of 14.7 psia) that has been converted to a liquid by a refrigeration process.

**liquefied natural gas**—a liquefied gas composed predominantly of methane and that can contain minor quantities of ethane, propane, nitrogen, or other components normally found in natural gas.

**long-term settlement**—occurs after the inflection point in the log time-void curve when the curve becomes a straight line.

**mockup**—a portion of a structure constructed to demonstrate construction techniques, finalize selection of materials and appearance, and serve as a basis for acceptable construction in the final structure.

**modulus of elasticity**—the ratio of normal stress to corresponding strain for tensile or compressive stress below the proportional limit of the material; also referred to as elastic modulus, Young's modulus, and Young's modulus of elasticity; denoted by the symbol  $E_c$ .

**mooring loads**—tension forces from a mooring line attached to a gravity base structure (during construction and installation) or to a floating hull (during installation and operation).

**nonlinear analysis**—a method of analysis in which the stresses are based on nonlinear material properties and the effects of cracking.

**operating basis earthquake**—maximum earthquake level a structure is expected to withstand with no damage and remain in an operable condition.

**overpressure**—the pressure increase above the set pressure at the relief valve inlet when the valve is relieving.

## CODE

## COMMENTARY

**overturning resistance**—resisting forces and moments of the soil and foundation against the forces and moments acting to overturn the structure.

**permanent ballast**—typically solid ballast permanently placed at lower locations in the structure to either assist in floating stability or increase the on-bottom weight of a gravity base structure to resist sliding and overturning.

**pipng load**—static loading, dynamic loading, or both, generated by piping and carried into the structure through piping supports.

**product**—the refrigerated liquefied gas being stored.

**purge**—removal of one gas type by another gas through a controlled and safe procedure.

**radius of curvature**—the radius of the unique circle defined by three nonlinear points in a plane. The center of the circle is the intersection of two bisectors of any two given points.

**refrigerated liquefied gases**—matter that occurs in a gaseous state at standard temperature and pressure and has been liquefied by refrigeration.

**ring beam**—continuous axial load and flexural element monolithic with the top perimeter of a cylindrical structure; or a continuous flexural element under the bottom perimeter of a cylindrical structure.

**safe shutdown earthquake**—maximum earthquake level a structure is expected to withstand with permanent damage but without a loss of overall integrity or containment.

**safe shutdown earthquake aftershock**—aftershock earthquake occurring after the main safe shutdown earthquake event, having a magnitude equal to 50 percent of safe shutdown earthquake event magnitude.

**sea ice**—an environmental load resulting from bearing or impacting of first-year sheet ice, multi-year ice floats, first-year and multi-year ice ridges, icebergs, or all, on a structure.

**shear modulus (soil)**—stiffness of soil against shearing deformation, below the proportional limit of the material.

**shear strength (soil)**—(1) the maximum unit stress a material is capable of resisting under shear loading; or (2) the maximum transverse force at a cross section under which a member remains in equilibrium under the combined effects of axial, shear, and flexural forces.

**sliding resistance**—the resisting force of the soil against the base of a foundation being pushed laterally.

**soil-structure interaction**—the process in which the response of the soil influences the motion of the structure and the motion of the structure influences the response of the soil.

**specified compressive strength of concrete**—the specified resistance of a concrete specimen to axial compressive loading used in design calculations and as a criterion for material proportioning and acceptance.

**stratification**—separation of a fluid into layers with varying densities.

**strength level earthquake**—maximum earthquake level a structure is expected to withstand with limited damage, with the return period as defined by the owner.

## CODE

## COMMENTARY

**stress relaxation**—the time-dependent decrease in stress in a material held at constant strain.

**storm surge**—an environmental load resulting from a flood of ocean or lake water that occurs in areas subject to tropical storms and bordering on shallow waters.

**tank**—a stationary containment structure with self-supporting, liquid-tight walls constructed of nonearthen material.

**thermal corner protection**—insulated and liquid-tight system to protect the outer tank corner joint from thermal shock.

**thermal load**—load in a structural element due to constrained volume changes produced by changes in temperature or temperature gradients within the element.

**thermal shock**—a rapid change in temperature that may be expected to have a potentially deleterious effect on a material or structure.

**topside facilities**—all the equipment and appurtenances on a floating hull or gravity base structure that are used for the processing of the refrigerated liquefied gas and operation of the facility.

**ultimate bearing capacity of soil**—capacity of soil/rock to support loads applied to the ground. The bearing capacity is the maximum average contact pressure between the foundation and the soil/rock that will not produce failure or unacceptable deformation.

**ultimate capacity of single piles**—load at which the settlement of the pile increases continuously with no further increase in load, or at which the settlement begins to increase at a rate far out of proportion to the rate of increase of the load.

**vapor barrier**—a barrier that passively limits the flow of refrigerated liquefied gas vapor, water vapor, or other atmospheric gases.

**working-stress design**—a method of proportioning structural systems to resist prescribed service loads at prescribed elastic stress levels.

## CODE

## COMMENTARY

**CHAPTER 3—REFERENCED STANDARDS***American Concrete Institute*

117-06—Specifications for Tolerances for Concrete Construction and Materials

301-05—Specifications for Structural Concrete

318-11—Building Code Requirements for Structural Concrete and Commentary

350-06—Code Requirements for Environmental Engineering Concrete Structures

350.3-06—Seismic Design of Liquid-Containing Concrete Structures

506.2-95—Specification for Materials, Proportioning, and Application of Shotcrete

*American Petroleum Institute*

API 620-08—Design and Construction of Large, Welded, Low-Pressure Storage Tanks, Eleventh Edition including Amendments

*American Society of Civil Engineers*

ASCE/SEI 7-05—Minimum Design Loads for Buildings and Other Structures

*American Society of Mechanical Engineers*

ASME B31.3 2006—Process Piping

*American Welding Society*

AWS D1.1/D1.1M-08—Structural Welding Code—Steel

*ASTM International*

A416/A416M-10—Standard Specification for Steel Strand, Uncoated Seven Wire for Prestressed Concrete

A615/A615M-09—Standard Specification for Deformed and Plain Carbon Steel Bars for Concrete Reinforcement

A706/A706M-09—Standard Specification for Low Alloy Steel Deformed and Plain Bars for Concrete Reinforcement

A955/A955M-11—Standard Specification for Deformed and Plain Stainless Steel Bars for Concrete Reinforcement

C39/C39M-11—Standard Test Method for Compressive Strength of Cylindrical Concrete Specimens

C109/C109M-11—Standard Test Method for Compressive Strength of Hydraulic Cement Mortars (Using 2 in. or [50 mm] Cube Specimens)

C144-11—Standard Specification for Aggregate for Masonry Mortar

C150/C150M-11—Standard Specification for Portland Cement

C260/C260M-10—Standard Specification for Air-Entraining Admixtures for Concrete

C469/C469M-10—Standard Test Method for Static Modulus of Elasticity and Poisson's Ratio of Concrete in Compression

C494/C494M-11—Standard Specification for Chemical Admixtures for Concrete



**CODE**

**COMMENTARY**

C496/C496M-11—Standard Test Method for Splitting Tensile Strength of Cylindrical Concrete Specimens

C512/C512M-10—Standard Test Method for Creep of Concrete in Compression

C618-08—Standard Specification for Coal Fly Ash and Raw or Calcined Natural Pozzolan for Use in Concrete

C989/C989M-11—Standard Specification for Slag Cement for Use in Concrete and Mortars

C1017/C1017M-07—Standard Specification for Chemical Admixtures for Use in Producing Flowing Concrete

C1202-10—Standard Test Method for Electrical Indication of Concrete's Ability to Resist Chloride Ion Penetration

C1240-11—Standard Specification for Silica Fume Used in Cementitious Mixtures

C1679-09—Standard Practice for Measuring Hydration Kinetics of Hydraulic Cementitious Mixtures Using Isothermal Calorimetry

D1143/D1143M-07—Standard Test Methods for Deep Foundations Under Static Axial Compressive Load

D3689-07—Standard Test Methods for Deep Foundations Under Static Axial Tensile Load

D4945-08—Standard Test Method for High Strain Dynamic Testing of Piles

E96/E96M-10—Standard Test Methods for Water Vapor Transmission of Materials

*British Standards Institute*

BS 4449:2005/+A2:2009—Steel for the Reinforcement of Concrete

BS 4486:1980—Specification for Hot Rolled and Hot Rolled and Processed High Tensile Alloy Steel Bars for the Prestressing of Concrete

BS 5896:1980—Specification for High Tensile Steel Wire and Strand for the Prestressing of Concrete

BS 6744:2001—Stainless Steel Bars for the Reinforcement of and Use in Concrete. Requirements and Test Methods

BS EN 1992-1-1—Design of Concrete Structures, General Rules and Rules for Buildings

*Canadian Standards Association*

CAN/CSA-G30.18-M92—Billet-Steel Bars for Concrete Reinforcement

*European standards*

EN 14620-3:2006—Design and Manufacture of Site Built, Vertical, Cylindrical, Flat-Bottomed Steel Tanks for the Storage of Refrigerated, Liquefied Gases with Operation Temperatures between 0 °C and -165 °C—Part 3: Concrete Components

EN 1992-1-1—Eurocode 2: Design of Concrete Structures – Part 1-1: General Rules and Rules for Buildings

*International Standards Organization (ISO)*

ISO 4624:2002—Paints and Varnishes—Pull-Off Test for Adhesion

**CODE**

**COMMENTARY**

*National Fire Protection Association (NFPA)*

NFPA 59A-09—Standard for the Production, Storage, and Handling of Liquefied Natural Gas (LNG)

*Precast Prestressed Concrete Institute*

MNL-116-99—Manual for Quality Control of Plants and Production of Precast and Prestressed Concrete Products

These publications may be obtained from these organizations:

American Concrete Institute  
38800 Country Club Drive  
Farmington Hills, MI, 48331  
[www.concrete.org](http://www.concrete.org)

American National Standards Institute  
1819 L Street, NW  
Washington, DC 20036  
[www.ansi.org](http://www.ansi.org)

American Petroleum Institute  
1220 L Street, NW  
Washington, DC 20005.  
[www.api.org](http://www.api.org)

American Society of Civil Engineers  
1801 Alexander Bell Drive  
Reston, VA 20191  
[www.asce.org](http://www.asce.org)

American Society of Mechanical Engineers  
Three Park Avenue  
New York, NY 10016  
[www.asme.org](http://www.asme.org)

ASTM International  
100 Barr Harbor Dr.  
West Conshohocken, PA 19428-2959  
[www.astm.org](http://www.astm.org)

British Standards Institute  
389 Chiswick High Road  
London, W4 4AL, United Kingdom  
[www.bsi-global.com](http://www.bsi-global.com)

Canadian Standards Association  
5650 Spectrum Way  
Mississauga, ON  
L4W 5N6 Canada  
[www.csa.ca](http://www.csa.ca)

International Organization for Standardization (ISO)  
1, rue de Varembe  
Case postale 56  
CH-1211 Geneva 20  
Switzerland  
[www.iso.org](http://www.iso.org)

**CODE**

**COMMENTARY**

National Fire Protection Association  
1 Batterymarch Park  
Quincy, MA 02169  
[www.nfpa.org](http://www.nfpa.org)

Precast/Prestressed Concrete Institute  
209 W. Jackson Blvd. #500  
Chicago, IL 60606  
[www.pci.org](http://www.pci.org)

**CODE****COMMENTARY****CHAPTER 4—MATERIALS****4.1—Testing of materials**

**4.1.1** Testing of materials used in concrete construction shall conform to applicable building codes and the licensed design professional.

**4.1.2** Testing of materials shall be made in accordance with the applicable ACI and ASTM (or comparable) standards listed or referenced by this code except where indicated.

**4.1.3** Testing shall be performed at ambient temperature except where indicated by this code that they shall be performed at cryogenic temperature appropriate to the liquid to be stored.

**4.1.4** The complete record of material tests in accordance with 4.1.3.2 shall be available for inspection during the progress of the work, and a complete set of these documents shall be preserved by the owner through the life of the tank.

**4.1.5** Records of all performance-related tests shall be maintained for the life of the structure.

**4.2—Cementitious materials**

Portland cement, fly ash, slag cement, and silica fume shall conform to ASTM C150, ASTM C618, ASTM C989, and ASTM C1240, respectively.

**4.3—Aggregates**

Aggregates, including lightweight aggregates, used in making concrete shall conform to ACI 350 and the aggregate shall be selected so that the concrete meets the cryogenic performance requirements given in this code with regard to cracking, thermal conductivity, and permeability.

**R4.1—Testing of materials**

**R4.1.1** Acceptable standard material tests at ambient temperatures are referenced in ACI 350 and ACI 318 for concrete and conventional reinforcing steel and general ASTM standards (or comparable) for general materials. Other tests are listed in this code.

**R4.1.3** Results from low-temperature tests performed on concrete can be significantly influenced by the history of the specimen (cooling/heating), the cooling/heating rate, and the temperature range.

The physical properties of nonprestressed reinforcement and prestressing steels are almost independent of the test specimen's thermal history; however, care should be taken when testing massive steel specimens to ensure that thermally-induced internal stresses do not influence the test results.

**R4.2—Cementitious materials**

Impermeability and durability of concrete may be increased by the use of fly ash, slag cement, or silica fume as part of the cementitious materials. The use of fly ash or slag cement can assist in the reduction of heat development in large sections during hydration, and hence reduce the risk of thermal cracking. The use of fly ash or silica fume can also mitigate the effects of alkali-aggregate reactivity and can be verified using ASTM C441 and ASTM C311.

**R4.3—Aggregates**

The coarse aggregates can have a large influence on the coefficient of thermal expansion of concrete, thermal conductivity, behavior in fire, and impermeability to cryogenic fluids. Aggregates for use in concrete for primary containment should have a low coefficient of thermal expansion, but not so low that incompatibility with the cement matrix can lead to cracking at the aggregate/matrix interface and consequent increased permeability. Some experimental work has shown that lightweight coarse aggregate can be used to produce concrete with significantly lower intrinsic permeability to cryogenic fluids than normalweight aggregates (Hanaor 1982). This is principally due to enhanced bond between the coarse aggregate and the matrix due to elastic stiffness compatibility. Also, the contact zone of

**CODE**

**COMMENTARY**

**4.4—Water**

Water used in mixing concrete shall conform to ACI 350.

**4.5—Admixtures**

**4.5.1** Admixtures for water reduction and setting time modification shall conform to ASTM C494. Admixtures for use in producing flowing concrete shall conform to ASTM C1017.

**4.5.2** Air-entraining admixtures shall conform to ASTM C260.

**4.5.3** Admixtures to be used in concrete that do not conform to 4.5.1 and 4.5.2 shall be subject to prior approval by the licensed design professional.

**4.5.4** Where two or more admixtures are used in concrete, their compatibility shall be checked and documented in accordance with ASTM C1679.

**4.5.5** Calcium chloride or admixtures containing chloride from sources other than impurities in admixture ingredients shall not be used in prestressed concrete, in concrete containing embedded aluminum, or in concrete cast against stay-in-place galvanized steel forms.

**4.6—Fibers**

**4.6.1** The use of fiber-reinforced concrete or fiber-reinforced shotcrete shall be permitted.

**4.6.2** Polypropylene or other synthetic fiber used to improve resistance to spalling of concrete in fire shall have documented evidence from the producer of satisfactory performance in a temperature range to which the concrete will be exposed in service.

**4.7—Deformed reinforcement**

**4.7.1** *Deformed reinforcement at service temperatures down to 0°F*—Deformed reinforcing bars used when design temperature is equal to or greater than 0°F shall be uncoated deformed bar conforming to the requirements of ASTM

aggregate and matrix consists of two porous media, thus eliminating the weak zones caused by water accumulation.

**R4.4—Water**

ASTM C1602 can be used for the mixing water requirements.

**R4.6—Fibers**

**R4.6.1** Steel fibers can be used in concrete to improve certain properties (refer to ACI 544.3R and ACI 544.4R), including:

- a) Compressive ductility
- b) Tensile strength and ductility/toughness
- c) Shear strength and ductility
- d) Crack control
- e) Fatigue resistance

Actual properties will depend on the amount and type of fiber used, as described in 544.1R.

**R4.6.2** Polypropylene and some other synthetic fibers have been used in practice to minimize spalling of concrete in fire and improve overall fire resistance of a structure (Bilodeau et al. 1997; Hoff 1998). Documented evidence can be provided by laboratory testing.

Not all types of polymer fiber provide the same level of protection against spalling in fire. Discrete fibers are more effective than fibrillated fibers (ACI 544.1R). Some research has shown that the proportion of fiber required to prevent spalling is greater in prestressed concrete than normally reinforced concrete, and that the proportion increases with the level of prestress.

**R4.7—Deformed reinforcement**

**R4.7.1** Deformed reinforcement conforming to ASTM A615, Grade 60, has been used on a number of refrigerated liquefied gas (RLG) storage tanks to accommodate the following conditions:

## CODE

A615, Grade 60; ASTM A706; or BS 4449, Grade 460, with a yield strength not less than 60,000 psi.

**4.7.2 Deformed reinforcement at service temperatures below 0°F**—For the design of reinforced concrete components exposed to either service or accidental cryogenic conditions, the selection of the nonprestressed steel reinforcement shall be based on ductility and toughness and shall comply with at least one of the following:

- a) For carbon steel reinforcement, including steel conforming to 4.7.1, the resulting tensile stresses shall not exceed the following:

Bar diameter*	Maximum allowable stresses, <sup>†</sup> psi
0.500 in. and smaller (No. 3 and 4)	12,000
0.625 in. to 0.875 in. (No. 5, 6, and 7)	10,000
1.000 in. and larger (No. 8 and larger)	8000

\*U.S. customary bar designations in parentheses. The limits of this table are applicable to soft metric conversion of ASTM A706 and nominal metric sizes of CAN/CSA G30.18-M92.  
<sup>†</sup>For ASTM A706 and Grades 400W and 500W of CAN/CSA G30.18-M92.

- b) Steel that satisfies the requirements of EN 14620-3:2006, Annex A, and the requirements of 4.7.1 and 4.7.2.  
 c) Fully austenitic stainless steel high-yield deformed reinforcing bars conforming to the requirements of ASTM A955, Grade 60; or BS 6744, Grade 500, with a yield strength not less than 60,000 psi.

#### 4.8—Plate steel composite with concrete

Selection of plate steel used as reinforcement acting in composite action with concrete shall be based on the requirements of API 620, Appendix Q or R, as applicable for the design metal temperature corresponding to minimum service temperature at the surface of the plate.

## COMMENTARY

- a) In concrete components that are not expected to be exposed to temperatures below 0°F during service  
 b) Accidental conditions  
 c) Under temporary stresses during construction  
 d) In concrete components exposed to either service or accidental cryogenic conditions, provided the resulting tensile stresses (exclusive of direct temperature and shrinkage effects) do not exceed the allowable stress values specified in 4.7.2(a)—these allowable stress values are originally from NFPA 59A.

**R4.7.2** The general effect of low service temperatures on nonprestressed reinforcement is to increase the yield and tensile strength and reduce the ductility and fracture toughness. Selection of cryogenic reinforcement should, therefore, take these fundamental property changes into account.

Resulting stresses include, but are not limited to, mechanical as well as deformation-induced stresses. When the limiting stresses are exceeded, the nonprestressed reinforcement should be considered ineffective.

The types of deformed reinforcing bars acceptable for cryogenic application depend on design temperature and type of containment structure. ASTM A615, Grade 60, is acceptable for applications above 0°F. ASTM A706, Grade 60, is acceptable for applications above -20°F and offers advantages with regard to ductility, strength, and constructibility as compared with ASTM A615 steel. At lower temperatures, where toughness is important, the following classes should be used:

- a) Micro-alloyed carbon-manganese steels (Krybar 1981)  
 b) Austenitic steels, 25 Mn 5 Cr 1 Ni (Nippon Steel Corporation 1980)  
 c) Austenitic-ferritic steels, 9 percent Ni steel (Nippon Kokan 1980)

For metal liners used as reinforcement in composite action with the concrete, refer to 4.8. For the testing details and acceptance criteria, refer to Fédération Internationale de la Précontrainte (FIP) (1988).

The Notch Sensitivity Ratio described in BS EN 14620-3:2006 provides an indication of the effect of notching the bar at the minimum service temperature. In adopting this approach, consideration should be given to the reinforcement manufacturing process that could have a significant effect on the validity of the approach. In the case of bars involving cladding or different processes of quenching and tempering during production to control the microstructure of the steel, the depth of the notch could result in different material microstructures being sampled relative to the bar size.

#### R4.8—Plate steel composite with concrete

Selection of plate material in API 620, Appendixes Q and R, depends on design metal temperature as follows:

- a) Appendix Q is applicable to product temperatures to -270°F  
 b) Appendix R is applicable to product temperatures at +40 to -60°F

**CODE****4.9—Prestressed reinforcement**

**4.9.1** Provisions of 4.9 shall apply to single strands and wires, multi-strand tendons, and bars.

**4.9.2** The strand for circumferential prestressing systems shall comply with the provisions of ASTM A416 and Chapters 3 and 18 of ACI 350. Strands that do not comply with these provisions shall comply with other national or international codes with the approval of the engineer.

**4.9.3** Steel for wire-wound prestressing shall comply with the provisions of ACI 350, Appendix G, for both field die-drawn and other wire-wound systems, or with BS 4486:1980 or BS 5896:1980.

**4.10—Prestressing anchorages****COMMENTARY****R4.9—Prestressed reinforcement**

**R4.9.1** Single strands are normally used for external circumferential wall prestressing and linear (vertical) wall prestressing. Single wires are used for external circumferential prestressing. Multi-strand tendons are used for internal circumferential wall prestressing and linear prestressing. Bars are used for linear prestressing.

Conventional prestressing strand and wire can be used at cryogenic temperatures because of the cold-drawing process and because the greatest load to the concrete structure occurs during construction when the tensile load is applied to the prestressing steel tendons or bars. The cold drawing process improves cryogenic ductility by inducing stress fields that inhibit crack propagation in the steel. The jacking stress (or pulling stress in the case of strand- or wire-wrapping) is normally 65 to 75 percent of the ultimate tensile strength.

Concerns about the failure of any strand or wire typically are minimal, but should be considered. After the initial prestressing process, when any existing microcrack in the steel is unloaded, elastically deformed material around the initial plastic zone imparts compressive stresses on the initial plastic zone. Brittle fracture can then only occur if the stress is increased beyond that of the original prestress.

Furthermore, due to the composite nature of prestressed concrete, the potential fracture of one single prestressing strand, wire, or bar leads to redistribution of its load over adjacent elements without propagating its failure to those elements. For fully-bonded systems within a short distance of the failed strand, wire, or bar, full strength is regained because of the bond between the steel and the concrete.

**R4.9.2** These provisions apply to strands used for multi-strand tendons for internal prestressing, and single strands for external circumferential strand wrapping. For strand materials that do not comply with ASTM A416, other relevant references can be used, such as FIP (1974). Stress relaxation of the strands should not have more than 2.5 percent loss after 1000 hours at ambient temperature from an initial stress of 70 percent of the specified minimum tensile strength. Mechanical properties should be assessed in accordance with FIP (1988).

Additional guidelines for the use of multi-strand tendons for internal tendon stressing or single strands for external strand wrapping, can be found in ACI 373R and 372R, respectively. The tendon assembly may also comply with FIP (1981).

**R4.10—Prestressing anchorages**

Anchor systems, such as wedge anchors for strands, can result in indentations that may affect the performance of the system.

**CODE****COMMENTARY**

The designer needs to identify those parts of prestressing anchorages that transfer the prestress load during service. It should be noted that once the ducts have been grouted, the end-anchorages may be redundant.

**4.10.1** Those parts of prestressing anchorages (wedge plate and anchor head) that transfer the prestress load during service and are subjected to either low or cryogenic temperatures shall be fabricated from alloy steels that comply with the ductility requirements of API 620, Appendix Q or Appendix R, as applicable for the service temperature.

**4.10.2** Other materials (for example, cast iron) can be used for parts of prestressing anchorages when satisfactory performance is demonstrated to the designer by means of appropriate tests as stipulated in BS EN 14620-3:2006.

**4.11—Post-tensioning ducts**

Post-tensioning ducts shall be in accordance with the requirements of 11.4.3.

**4.12—Grout**

Grout for bonded tendons shall be in accordance with the requirements of 11.4.5.

**4.13—Metal liners and nonstructural metal components**

**4.13.1** Plate steel used solely for primary or secondary containment of refrigerated liquefied gas (RLG) shall conform to the requirements of API 620, Appendix Q or R, depending on the temperature range.

**4.13.2** Nonstructural metallic barriers incorporated in, and functioning compositely with, prestressed concrete subject to design temperatures between  $-60$  and  $-270^{\circ}\text{F}$  during normal operation conditions shall be of metal classified for either “primary components” or “secondary components” in API 620, Appendix Q.

**4.13.3** All nonstructural metallic barriers in the concrete wall and the base slab shall be of carbon steel conforming to Table R-4 of API 620.

Carbon steel vapor barrier plates attached to the concrete wall shall be in conformance with material requirements for the secondary components as defined by API 620, Appendix R, at service temperatures.

**4.13.4** Roof liner plates and bottom vapor barrier plates shall be fine-grain carbon steel conforming to the design requirements in Table R-4 of API 620.

**4.13.5** Welding procedures shall comply with Section R.6 of API 620 for primary components as defined in Appendix Q of API 620.

**R4.13—Metal liners and nonstructural metal components**

**R4.13.1** The metal liners should be considered as nonstructural unless they also function as reinforcement in composite elements as described in 4.8.



**CODE**

**4.13.6** All internal pump columns, stilling wells, stand-pipes, internal piping, fittings, attachments, and guides shall conform to the requirements of API 620 for the design service temperature of the component.

**4.14—Insulation**

Insulation material shall meet the requirements of 7.3.5 of NFPA 59A.

**4.15—Coating requirements**

Coatings shall comply with the criteria of 6.8.

**COMMENTARY****R4.14—Insulation**

The requirements of 7.3.5 of NFPA 59A are for liquefied natural gas (LNG) tanks. Unless otherwise specified in the project documents, the same requirements can be applied to refrigerated liquefied gas (RLG) tanks.

Structural concrete has little insulation value for minimizing resistance to heat leaks into the tank under steady-state conditions. It is effective, however, in protecting the primary tank and contents from the effects of fire because of the thermal mass of the concrete that prevents rapid temperature changes through its thickness.

Insulation is achieved with materials that entrap significant quantities of quiescent gas, and generally, a stronger and denser material is less effective as insulation (fabricated composite materials may break this trend).

Insulation is classified as load-bearing or non-load-bearing.

Suitable materials for load-bearing insulation include (highest conductivity first, then decreasing):

- a) Insulating lightweight concrete such as perlite concrete, cellular concrete, or concrete with polystyrene beads
- b) Wood
- c) Foamed glass
- d) Foamed plastics
- e) Polyurethane
- f) Composite materials

Suitable materials for non-load-bearing insulation include (highest conductivity first, then decreasing):

- a) Perlite
- b) Foamed plastics
- c) Fiberglass
- d) Mineral wool
- e) Polyurethane
- f) Composite materials

## CODE

## COMMENTARY

## CHAPTER 5—DESIGN LOADS

**5.1—Design loads**

**5.1.1 Dead loads  $D$** —Dead loads shall include, but are not limited to, the following loads:

- a) Inner tank weight
- b) Roof weight
  - i. Roof liner and structural framing
  - ii. Concrete roof section
- c) Pump well, pump, and pump effects
- d) Suspended deck weight
- e) Insulation weight
  - i. Side insulation
  - ii. Bottom insulation including all components that comprise the system (leveling courses, plate, and insulation)
  - iii. Suspended deck insulation
- f) Weight of appurtenances, equipment, and permanent machinery (for example, platform, inner stair, valves, pumps, steel structure, and piping)
- g) Self-weight of foundation including soil weight
- h) Weight of concrete walls
- i) Caisson weights (if applicable)
- j) Permanent ballast weight (if applicable)

**5.1.2 Prestressing forces  $P_t$ ,  $P_1$** —Vertical prestressing in the wall and the effect of circumferential prestressing force in the wall and in the top or bottom ring-beam shall be considered.

The jacking force and allowance for the following sources of loss of prestress shall be considered:

- a) Elastic shortening of concrete
- b) Prestressing steel seating at transfer
- c) Creep of concrete
- d) Shrinkage of concrete
- e) Relaxation of prestressing steel stress
- f) Friction loss due to curvature and wobble in post-tensioning tendons

**5.1.3 Product pressure and weight,  $F$** —Effects of product include:

- a) Hydrostatic pressure  $P_d$
- b) Hydrodynamic pressure
- c) Gas pressure, vapor pressure, or both
- d) Product weight  $F$

Effects of both internal positive and negative pressure shall be considered.

**5.1.4 External pressures**—External pressures shall include:

- a) Soil (backfill) loading—external lateral earth pressure due to both permanent earth backfill ( $F_v$ ), and the surcharge effect of live and other loads supported by the earth acting on the structure shall be considered
- b) Ground water pressure
- c) Hydrostatic and hydrodynamic (for example, waves) loading from liquids external to the tank

**R5.1—Design loads**

**R5.1.2** The effects of prestressing forces at all stages of construction, service, and decommissioning should be considered.

**R5.1.4** This code is not applicable to fully-buried, fully-backfilled refrigerated liquefied gas (RLG) storage tanks that require a heating system to prevent the propagation of the freezing isotherm around the tank wall.

**CODE**

**COMMENTARY**

**5.1.5 Thermal and moisture-gradient loading ( $T_e, T_o$ )**—The results of thermal and moisture-gradient loading shall be considered for through-member thickness along and between members for effects resulting during tank cooling and filling and from normal thermal and moisture-gradient loading under normal operation conditions.

**5.1.6 Construction-specific loads**—Loads related to construction activities, such as, but not limited to, loads from construction equipment, temporarily stored materials, shoring, and scaffolding, shall be considered.

**5.1.7 Testing, commissioning, and decommissioning loads**—Loads related to testing, commissioning, and decommissioning shall be considered. These loads include, but are not limited, to:

- a) Hydrostatic and pneumatic tank-testing loads ( $P_t, P_v, F_t$ )
- b) Installation loads (for example, tow-out conditions)
- c) Thermally-induced loads experienced during tank purging, cooling, and filling
- d) Thermally-induced loads experienced during tank warm-up

**5.1.8 Installation loads**—Loads related to tank installation activities shall be considered.

**5.1.9 Shrinkage- and creep-induced loads**—Shrinkage- and creep-induced loads shall be considered using material properties indicated in Chapter 4.

**5.1.10 General live loads  $L$** —General live loads shall include:

- a) Uniformly distributed roof load  $R$
- b) Concentrated roof load—a minimum value of 1000 lb, distributed over an area of 1 ft<sup>2</sup>, shall be considered
- c) Live loads on caisson elements (if applicable)

**R5.1.5** Temperature design loads include loads developed as the result of both transient and steady-state thermal gradients due to differential time rate of cooling between the concrete wall, steel embedments, and wall liner. Attachment loads developed in the wall at the thermal corner protection (TCP) location due to a steady-state thermal gradient between the wall embedment and secondary bottom are included in this load category.

Necessary details of the moisture-gradient loading should be provided in the project specifications.

Normal thermal and moisture-gradient loading experienced under normal operation conditions are loads developed when the refrigerated liquefied gas (RLG) is stored within the inner tank during normal operation. The thermal profiles are normally derived from steady- and transient-state thermal analyses of the entire tank.

**R5.1.6** Construction-specific loads, including placing the concrete roof, are temporary loads to which the structure is subjected during various stages of construction, or as a result of special construction requirements. Loads due to prestressing should be addressed in accordance with 5.1.2.

**R5.1.7** Testing and commissioning loads are the loads associated with the hydrostatic testing, pneumatic testing, hydropneumatic testing, and cool-down of the primary container.

Bund walls and secondary containment walls are normally not subject to these conditions. A secondary containment wall in a full-containment system, however, is subject to pneumatic testing.

**R5.1.8** Installation loads are related to tank installation activities, such as those experienced during installation of offshore concrete tank structures. Examples include loads during float-out and towing. For additional information, refer to Appendix B.

**R5.1.10** General live loads are loads that may change during the mode of operation being considered. Examples include:

- a) The weight of temporary equipment that can be removed
- b) The weight of crew and consumable supplies
- c) The weight of fluids in pipes and vessels other than the primary tank during operation and testing
- d) The weight of fluids in storage and ballast tanks
- e) Forces exerted on the structure due to terminal operations
- f) Forces exerted on the structure during operation of cranes and vehicles

## CODE

## COMMENTARY

**5.1.11 Differential settlement**—Short- and long-term differential settlement-induced loading ( $F_s$ ) shall be determined by analysis and applied to the tank as deformation loads.

**5.1.12 Environmental loads**—Environmental loads shall include:

- a) Roof loading  $R$ —A minimum uniformly distributed loading of 25 lb/ft<sup>2</sup> shall be used
- b) Snow loading—Shall be determined in accordance with ASCE/SEI 7 or with a probabilistic approach. Where a probabilistic approach is used, a 100-year mean recurrence interval shall be used
- c) Wind loading  $W$ —Shall be based on the 3-second gust and shall be determined in accordance with ASCE/SEI 7 or with a probabilistic approach. Where a probabilistic approach is used, a 100-year mean recurrence interval shall be used
- d) Ice loading—Includes both ice accumulated on the structure as well as water-borne ice and iceberg loading
- e) Ambient temperature and moisture fluctuations—induced loading
- f) Waves (if applicable)
- g) Current (if applicable)
- h) Flooding (if applicable)

Environmental loads shall be applied to the structure from directions producing the most unfavorable effects on the structure, unless site-specific studies provide evidence in support of a less-stringent requirement. Directionality shall be taken into account in applying the environmental criteria.

**5.1.13 Seismic loads**—The ground motion response spectra for horizontal and vertical directions shall be determined for both the operating basis earthquake (OBE) and the safe shutdown earthquake (SSE). The OBE spectrum shall have a return period of 475 years (10 percent chance of exceedance in 50 years), and the SSE spectrum shall have a return period of 2475 years (2 percent chance of exceedance in 50 years). In the United States, the OBE and SSE spectra can be developed from the U.S. Geological Survey (USGS) analysis or from site-specific probabilistic seismic hazard analysis. If a site-specific analysis is carried out, the OBE and SSE spectra shall not be less than 80 percent of the USGS spectra adjusted for local site conditions.

The response spectrum for the largest aftershock of an SSE ( $SSE_{aft}$ ) shall be half of the SSE response spectrum. If adequate information is not available to develop the vertical response spectra, ordinates of the vertical response spectra

While environmental loads are also a type of general live loads, they are categorized separately. For the uniformly distributed roof loads, refer to 5.1.12.

**R5.1.12** It should be noted that both API 620 and 650 require a minimum roof live load of 20 lb/ft<sup>2</sup>. BS EN 14620, Part 1 requires a minimum roof live load of 25 lb/ft<sup>2</sup>.

Effects of both highest and lowest ambient temperatures should be considered. The stress-free temperature for concrete should be included within the analysis. In the absence of detailed calculations, this should be taken as 68°F. Other examples of ambient temperatures include:

- a) Maximum seasonal average ambient temperature
- b) Slab temperatures commensurate with external ambient conditions (for example, elevated slab)
- c) Forced and free convection commensurate with wind and still-air conditions
- d) Solar radiation effects

Effects of waves, current, flood, and related loads that pertain to offshore concrete tank structures should be treated as described in Appendix B of this code.

The pressure differential between the interior and exterior of a confining, or partially confining, structure should be considered.

As per ASCE/SEI 7, extreme-value statistical analysis procedures should be used in evaluating wind data available in the vicinity of the site.

National regulations and pertinent local permits should also be reviewed by the design team for any environmental design loadings that may be more stringent than ASCE/SEI 7 and a 100-year recurrence interval.

While seismic loads are also a type of environmental loading, they are categorized separately.

**R5.1.13** The seismic design requirements in this code are consistent with seismic provisions in NFPA 59A for a two-level earthquake criteria. OBE and SSE ground motions are probabilistic 475-year and 2475-year return period ground motions, respectively. The SSE ground motions correspond to probabilistic maximum considered earthquake (MCE) ground motions as defined in ASCE/SEI 7. For site-specific analysis, only probabilistic MCE ground motions are used to limit the site-specific response spectrum rather than the lesser of the probabilistic and deterministic limits as permitted by ASCE/SEI 7. This more conservative approach for site-specific analysis is used for the following reasons:

- a) The MCE ground motions in the ASCE/SEI 7 were developed for the purpose of designing buildings and other structures in the U.S. The rationale behind the MCE ground motions may not be compatible with the rationale employed outside the U.S.

**CODE**

shall not be less than 2/3 of those of the horizontal response spectra. If adequate information is available, the corresponding ratio shall not be less than 1/2.

**5.1.14** *Explosion and impact* (B, M<sub>i</sub>)—Both external and internal loadings shall be considered if required by the project specifications. These shall include:

- a) Blast or other pressure-wave loading
- b) Impact loading
- c) Vehicle (or other nonflying object) loading
- d) Impact of windborne object

**5.1.15** *Thermal and moisture-gradient loading under spill conditions*—The result of thermal and moisture-gradient loading under different spill conditions includes through-member thickness along and between members effects. These conditions are:

- a) Short term (that is, the entire transient phase)
- b) Long term (that is, steady-state conditions)

**5.1.16** *Fire* H—Both external and internal fire effects shall be considered as required by project and regulatory requirements.

**COMMENTARY**

b) In certain regions and under certain conditions, the truncation of the probabilistic MCE ground motions by the deterministic limit reduces the return period of the MCE ground motions to as low as 700 years.

The OBE ground motion is uncoupled from the SSE ground motion by not requiring it to be a specified fraction, such as 1/2 or 2/3 of the SSE ground motion. The ratio of the 475-year to 2475-year ground motion return periods vary by region. This would result in different levels of risk in different parts of the world. To achieve uniformity in risk, the OBE ground motions are defined to have a return period of 475 years throughout the world.

The SSE aftershock (SSE<sub>aft</sub>) is not considered as the OBE, but defined as half of the SSE. This is because the ratio between the OBE (475-year) and the SSE (2475-year) ground motions is different at different locations, but the ratio between the aftershock and the main shock should nearly be the same throughout the world. Therefore, the SSE<sub>aft</sub> is considered to be half of the SSE.

For the purpose of preliminary design in the U.S., the OBE and SSE ground motions may be obtained by applying the ASCE/SEI 7 soil amplification factors to the 475- and 2475-year ground motions from USGS, assumed to be for Site Class B (firm rock, average shear wave velocity of  $V_s = 2500$  fps in the top 100 ft). For final design, the soil amplification factors should be obtained from the site-specific dynamic response analysis of the site (Schnabel et. al 1972).

For the purpose of preliminary design outside of the U.S., the peak ground accelerations generated under the Global Seismic Hazard Analysis Program (GSHAP) may be assumed to be OBE for firm rock sites. They should be appropriately adjusted for other site conditions (soil types) and converted to spectral response accelerations using suitable procedures by a geotechnical specialist. For final design, the OBE and the SSE should be determined from site-specific probabilistic seismic hazard analysis and dynamic response of the site.

**R5.1.14** Local impact effects may include penetration, perforation, scabbing, and punching shear. Refer to Appendix B for information on ship impact loading.

**R5.1.15** Definition of the moisture-gradient loading required for design of the structure should be provided in the project specifications.

**R5.1.16** External fire effects, internal fire effects, and pressure-relief stack (tailpipe) fire should be considered. Modes of fire and resulting heat fluxes should be defined by

## CODE

## COMMENTARY

**5.1.17 Other hazards**—Loading due to other hazards defined by a risk assessment shall be considered.

**5.2—Loading conditions****5.2.1 Types**

**5.2.1.1 Normal loading conditions**—The following loads shall be considered as normal loading conditions:

- a) Dead loads  $D$
- b) Prestressing loads  $P_f, P_i$
- c) Product pressure on inner tank,  $F$
- d) External pressure
- e) Normal thermal and moisture-gradient loads under operation conditions,  $T_e, T_o$
- f) Construction, testing, commissioning, and decommissioning loads
- g) Shrinkage-induced loads  $T$
- h) General live loads  $L$
- i) Differential settlement loads  $T$
- j) Environmental loads
- k) Site-specific loads, including partial snow loads, ice loads, or both

**5.2.1.2 Abnormal loading conditions**—The following loads shall be considered as abnormal loading conditions:

- a) Seismic loads  $E_o, E_s$
- b) The secondary containment shall be designed to resist product spilled into the outer tank. The height of the secondary containment shall be able to contain the maximum liquid content of the inner tank. All different cases of product spilling into the outer tank shall be considered, including:
  - i. Gradual leakage of the product from the inner tank into the annular space between shells
  - ii. Transient and steady-state thermal gradients and thermal loads resulting from product spilled into the outer tank
  - iii. Overfill of the inner tank,  $P_e$
- c) External explosion and impact loading,  $B, M_i$
- d) Fire  $H$
- e) Site-specific abnormal loads as identified through project risk assessment

**5.2.2 Load combinations for concrete structure**—Load combinations occurring during all stages of construction and the entire life of the structure shall be considered. These include:

a quantitative risk analysis (QRA). External fires may be the result of an adjacent tank fire, impoundment fire, or process equipment fires.

**R5.2—Loading conditions**

**R5.2.1.2** Multiple independent liquid level controls should be included and be provided with alarms and shut-down capability. Multiple alarm points and the distance between alarms should be determined from an evaluation of the operation conditions and the required time interval between alarm points. After the shutdown alarm, sufficient freeboard should be provided such that the liquid level does not exceed the maximum allowable liquid level.

Product spills into the outer tank can vary from a small spill to a large spill. Small spills are typically spills whose resultant liquid levels are not above the top of the thermal corner protection (TCP). Therefore, the concrete wall and foundation typically do not experience significant thermal gradients as a result of the spill. Large spills are spills whose resultant liquid levels are above the top of TCP. Therefore, the concrete wall is subject to significant thermal gradients during both the transient and steady-state phases. If multiple independent liquid level controls are used, overfill might not have to be considered.

In the case of offshore structures, refer to Appendix B for guidance on the abnormal loading conditions.

**R5.2.2** Table 5.2.2 is a load combination matrix. Each column lists loads that occur during a stage or event of the structure's life cycle, such as:

CODE

COMMENTARY

Table 5.2.2—Load combinations for concrete structure

Loading conditions		Normal loading conditions				Abnormal loading conditions					
		Construction	Installation	Testing and commissioning	Operation	Spill	Earthquake			Explosion and impact	Fire
Loading types	Spill + SSE <sub>aft</sub>						OBE	SSE			
Dead loads		X	X	X	X	X	X	X	X	X	X
Prestressing loads	General	X	X	X	X	X	X	X	X	X	X
	At anchorages	X	X	X	X						
Product pressure	Vapor/gas/vacuum			X (secondary tank)*	X (secondary tank)*	X (secondary tank)*	X (secondary tank)	X (secondary tank)	X (secondary tank)	X (secondary tank)	
	Liquid			X (primary tank)	X (primary tank)	X (secondary tank)	X (secondary tank)	X (primary tank)	X (primary tank)	X (primary tank)	X (primary tank)
Thermal and/or moisture	Normal	X	X	X	X			X	X	X	
	Spill					X	X				
	Fire										X
Construction and commissioning loads	Construction-operation loads	X									
	Installation loads		X								
	Tank-testing loads			X							
	Thermally-induced tank cooling and filling loads				X						
Shrinkage		X	X	X	X	X	X	X	X	X	X
Creep		X	X	X	X	X	X	X	X	X	X
General live loads		X	X	X	X			X	X	X	
Differential settlement		X	X	X	X	X	X	X	X	X	X
Environmental loads: wind		X	X	X	X						
Environmental loads: other		X	X	X	X						
Seismic loads	Operating basis earthquake							X			
	Safe shutdown earthquake					X			X		
Explosion and impact										X	
Fire											X

\*Will also apply to the primary tank of a single-wall tank system

**CODE**

- a) Normal loading conditions
  - i. Construction-related loading conditions
  - ii. Installation-related loading conditions, including the sequence of construction and the post-tensioning sequence
  - iii. Testing and commissioning-related loading conditions
  - iv. Operation-related loading conditions
  - v. Decommissioning loads
- b) Abnormal loading conditions
  - i. Spill-related loading conditions
  - ii. Earthquake-related loading conditions
  - iii. Explosion or impact-related loading conditions
  - iv. Fire-related loading conditions

Other than the decommissioning loads, the types of design loads to be considered in each loading combination are defined in Table 5.2.2. The sequence of construction and post-tensioning shall be accounted for.

**COMMENTARY**Operations

load combination =  $D + P_f + (\text{liquid} + \text{vapor}) \text{ pressure} + \text{normal thermal and moisture} + \text{shrinkage} + \text{creep} + L + \text{settlement} + \text{environmental (wind and snow)}$

Note that normal thermal load is the gradient between the inner and outer faces of a concrete wall. For tank cooling, this would be replaced by the transient cool-down thermal and moisture conditions.

Abnormal

$D + P_f + (\text{liquid} + \text{vapor}) \text{ pressure} + \text{shrinkage} + \text{creep} + L + \text{settlement} + \text{normal thermal and moisture} + \text{seismic}$

or + spill thermal and moisture

or + fire thermal and moisture

Load factors are defined in 5.2.



## CODE

## COMMENTARY

CHAPTER 6—MINIMUM PERFORMANCE  
REQUIREMENTS**6.1—General**

Design of primary and secondary concrete containers shall comply with applicable requirements of ACI 350, minimum performance criteria defined in 6.2 through 6.5, and the materials requirements in 6.6 to 6.9 of this code.

**6.2—Primary concrete container**

**6.2.1** Minimum performance criteria presented in 6.2.2 through 6.2.16 shall be satisfied when a primary concrete container is used.

**6.2.2** The primary container shall remain liquid-tight under:

- a) Hydrotest
- b) Operation loads condition
- c) Operation loads plus operating basis earthquake (OBE) combination.

**R6.1—General**

This chapter prescribes mandatory requirements for performance of the container under specified loading conditions defined in 6.2 to 6.5 and requirements for those materials to be used in the tank construction in 6.6 to 6.9. Requirements for allowable stresses or deformations, maximum tolerable damage, or minimum serviceability are specified.

In general terms, these requirements are divided into strength requirements and serviceability requirements.

The following potential failure mechanisms should be considered:

- a) Loss of overall equilibrium
- b) Failure of critical sections
- c) Instability resulting from large deformations
- d) Excessive plastic or creep deformation

Serviceability requirements specify that the following effects and their influence on serviceability of a structure may be considered:

- a) Cracking and spalling
- b) Deformations
- c) Corrosion of reinforcement or deterioration of concrete
- d) Vibrations
- e) Leakage

Minimum serviceability requirements include the following:

- a) Maximum allowable compressive stress during prestressing
- b) Minimum residual compressive stress (in the circumferential and vertical directions) under both service loads and extreme event loading
- c) Maximum depth of cracks resulting from accidental spills
- d) Maximum stresses resulting from an operating basis earthquake (OBE) or safe shutdown earthquake (SSE) seismic event (refer to NFPA 59A, Section 7.2.2)
- e) Minimum serviceability requirements during service, and following an OBE or SSE event (refer to NFPA 59A, Section 7.2.2)

Applicable recommendations reported in ACI 372R and ACI 373R should be followed for design and installation of prestressed concrete tanks.

**R6.2—Primary concrete container**

## CODE

**6.2.3** Unless a leak-tight membrane/liner has been used, minimum requirements for liquid tightness in the concrete wall and in the concrete base shall be:

- a) Under empty and operation load conditions, the net resultant force in a section shall be compression.
- b) Under empty, operation load, and operation load plus OBE conditions, a compressive zone of either 50 percent of the section thickness or 8 in., whichever is greater, shall be maintained in both the vertical and the circumferential directions.
- c) Unless liquid tightness under given conditions is proven using other methods, a minimum residual average compressive stress within the compressive zone of 145 psi should be maintained in both the vertical and the circumferential directions.

**6.2.4** Tensile strength of concrete shall not be used when calculating the size of the uncracked zone, unless justified.

**6.2.5** The primary container shall retain its containment capability under SSE and SSE<sub>aft</sub> events.

**6.2.6** To assure containment capability for a concrete wall or concrete base without a leak-tight membrane/liner, a portion of the concrete shall remain in compression during and after SSE and SSE<sub>aft</sub> events. The compression zone shall be at least 25 percent of the section thickness or 4 in., whichever is greater.

**6.2.7** Ambient temperature material properties shall be used for design of concrete components under normal loading conditions.

**6.2.8** Under design loading, concrete compressive stress at transfer of maximum prestress shall not exceed  $0.55f_{ci}$ .

**6.2.9** Under normal conditions and based on uncracked section properties, the maximum concrete extreme fiber compression stresses at service loads shall not exceed:

- a) Extreme fiber stress in compression due to prestress plus sustained load:  $0.45f'_c$
- b) Extreme fiber stress in compression due to prestress plus total load:  $0.6f'_c$
- c) Extreme fiber stress in tension in precompressed tensile zone:  $0.6(f'_c)^{1/2}$

## COMMENTARY

**R6.2.3** The liquid tightness requirements are applicable for the empty, operation, and OBE conditions.

**R6.2.4** Before the tensile strength of the concrete can be included in the calculation of the size of the uncracked zone under safe shutdown earthquake (SSE) loading, various load combinations should be considered when determining if a section has been previously cracked. Previous loadings to be considered should include the following:

- a) Prestress
- b) Transient and steady-state thermal stresses
- c) Cool-down
- d) Hydrotest
- e) Normal operation
- f) Creep and shrinkage
- g) OBE

## CODE

**6.2.10** Under abnormal OBE conditions, the maximum extreme fiber concrete stresses in compression (based on uncracked section properties, and after allowance for all prestress losses) due to prestress plus total load shall not exceed the linear elastic region of the stress-strain curve defined in 6.2.11.

- a) Extreme fiber stress in compression due to prestress plus total load:  $0.85f_c'$
- b) Extreme fiber stress in tension in precompressed tensile zone:  $0.75(f_c')^{1/2}$

**6.2.11** Unless the limiting elastic concrete stress is determined using other methods, a concrete stress level of  $0.85f_c'$  shall be used as the limiting stress level of the linear elastic stress-strain region.

**6.2.12** The effects of restrained deformation shall be considered.

**6.2.13** Concrete and steel coefficients of thermal expansion at cryogenic temperatures shall be used.

**6.2.14** The coefficient of thermal contraction of the concrete structure shall be confirmed by testing the actual mixture over the range of the operational temperatures unless prior test data on this property is available.

**6.2.15** Design of the primary container shall comply with the following:

- a) Liquid tightness and containment criteria in 6.2.1
- b) Sufficient frictional resistance or anchorage to prevent sliding during seismic events as required in 10.3.4
- c) Sufficient freeboard shall be provided to accommodate liquid sloshing during OBE and SSE events
- d) Tensile stresses in primary component nonprestressed reinforcement shall not exceed the allowable stresses in 4.7.2

**6.2.16** When specified by the tank owner or other regulatory requirements, the fatigue performance criteria in Appendix C shall be applied.

## COMMENTARY

**R6.2.15** Sliding resistance is provided by frictional resistance between the primary container, bottom insulation, and secondary container bottom slab. Sliding could also be prevented by anchoring the primary container. The requirement that the container not slide under seismic loading implicitly defines a safety factor greater than 1.0 under any of the defined seismic events.

Unless dictated by the project requirements, the following guidelines should be considered to calculate the freeboard heights:

- a) Sloshing height due to OBE plus 1 ft
- b) Sloshing height due to SSE

Use the larger freeboard height for the primary tank.

**R6.2.16** Fatigue of the concrete in a refrigerated liquefied gas (RLG) or liquefied natural gas (LNG) primary concrete container is generally not a concern, but could be influenced by site conditions and operational practices. A preliminary evaluation or simplified fatigue check can be made before performing a detail fatigue assessment. The fatigue resistance can be considered adequate if a preliminary evaluation indicates that stresses and stress ranges in concrete, reinforcement, and prestress tendon are limited within the requirements as specified in Appendix C.

Fatigue of the secondary concrete container (refer to 6.3) is typically not a concern, and does not have to be checked unless required by the designer.

## CODE

**6.3—Secondary concrete container**

**6.3.1** Under spill conditions, the concrete above the thermal corner protection (TCP) shall remain liquid-tight, based on minimum depths of compression and precompression as defined in 6.3.2. The same liquid tightness requirements at spill shall also apply to the following parts of the tank:

- a) The wall above the TCP potentially in contact with spilled liquid when a TCP system and a secondary bottom are provided
- b) The bottom slab and wall potentially in contact with spilled liquid in case the TCP/secondary bottom are not provided

**6.3.2** To assure liquid-tightness under spill conditions of a secondary concrete container made without a leak-tight membrane/liner has been used, a minimum portion of the concrete shall remain in compression in accordance with the following:

- a) A compressive zone of either 10 percent of the section thickness or 3.5 in., whichever is greater, shall be provided
- b) A minimum average compressive stress within the compressive zone of 145 lb/in.<sup>2</sup> shall be maintained

**6.3.3** Calculated crack widths shall be considered at TCP embedment when cracking results in liquid product migrating behind the TCP and compromising its effectiveness. The embedment zone shall extend a minimum of two times the wall thickness above the TCP anchorage. Calculated crack widths shall not exceed 0.008 in. within the TCP embedment zone. Recommendations for crack width calculations are provided in 8.1.1.8.

**6.3.4** Under all conditions, including but not limited to spill, safe shutdown earthquake (SSE) and SSE<sub>aft</sub> plus spill events, the structural integrity of the wall shall be maintained.

**6.3.5** The secondary concrete containment shall be designed for the SSE<sub>aft</sub> event while containing the total volume of spilled product.

**6.3.6** Sufficient prestressing force and reinforcement shall be provided to prevent through-thickness cracking of concrete during the SSE<sub>aft</sub> event.

**6.3.7** Nonprestressed reinforcement, including plate steel used in composite action with concrete, shall comply with 4.7.1.

**6.3.8** Tensile stresses in nonprestressed reinforcement at service temperatures below 0°F shall be as defined in 4.7.2.

**6.3.9** The secondary tank shall not fail under the operating basis earthquake (OBE) and the SSE events while empty.

**6.3.10** Stresses in concrete after prestress transfer (before time-dependent prestress losses) shall not exceed  $0.55f_{ci}'$ .

## COMMENTARY

**R6.3—Secondary concrete container**

**R6.3.3** The complete temperature time history should be included for the embedment zone design. Often, the governing design loading may occur at different points within the time history due to different thermal response of the steel TCP embedment and the concrete wall.

**R6.3.4** The structural integrity is considered maintained when the liquid is contained and collapse is prevented.

**R6.3.7** Reinforced concrete is a heterogeneous material and the reinforcement elements are separate items. Fracture of one element entails redistribution of its load over adjacent elements without propagating its failure to those elements.

**R6.3.10** Refer to ACI 372R and ACI 373R for further information.

**CODE****COMMENTARY**

**6.3.11** Under normal conditions, the maximum concrete compression shall not exceed:

- a)  $0.45f_c'$  due to prestress plus sustained load
- b)  $0.6f_c'$  due to prestress plus total load

**6.3.12** Tensile stresses in prestressing steel shall not exceed the permissible stresses in ACI 350.

**6.3.13** Under normal design loading, excluding wind, calculated crack widths within the wall and the base slab shall not exceed 0.012 in.

**6.3.14** Effect of heat loss through the bottom that occurs under normal operation conditions and puts the central portion of the foundation into direct tension shall be included in the determination of the calculated crack width.

**6.3.15** In the case of full-containment tanks, vapor and moisture transmission through the secondary container shall be prevented by means of an impervious barrier under normal service conditions.

**6.3.15.1** If a metallic liner is used as an impervious barrier, it shall be considered impervious when meeting the requirements of 4.8 and 4.13.

**6.3.15.2** The liner material shall be capable of resisting service conditions without adverse long-term effect.

**6.3.16** *Nonmetallic liners*

**6.3.16.1** Selected methods for preventing vapor and moisture transmission through the secondary container shall be approved by the engineer.

**6.3.16.2** A nonmetallic liner shall be considered impervious when the barrier system, including barrier joints, satisfies the requirements of 6.8.2.

**6.4—Roof performance criteria**

The calculated crack widths shall not exceed 0.012 in. under normal operation conditions. Ultimate strength design shall be used for transient conditions, such as over pressure or seismic loading.

**6.5—Other performance criteria**

**6.5.1** If applicable, performance under loadings due to hazards such as blast or other pressure-wave loading, impact, and fire shall be specified as a part of the risk/hazard assessment.

**R6.3.15** Under normal service conditions, the vapor/moisture barrier provides protection to insulation that is commonly placed in the annular space between primary and secondary containment. Vapor and moisture barrier may be provided using metallic liners or polymeric coatings.

**R6.3.16.2** Bridging capability of the liner is dependent on the loading strain rate and temperature. During an OBE event, the vapor barrier can experience elongation strain rates induced by crack-opening velocities. The vapor barrier should remain functional after an OBE event.

**R6.5—Other performance criteria**

**R6.5.1** The performance when exposed to an explosion, blast, or other pressure-wave loading, impact, or fire should be determined as a part of the risk assessment. Concrete is known to resist the effects of high temperatures associated with cellulosic fires, but certain precautions should be taken to prevent excessive spalling or cracking of the concrete when hydrocarbon fires occur.

## CODE

## COMMENTARY

**6.6—Concrete quality**

Concrete shall be a mixture of portland cement or any other hydraulic cement or supplementary cementing material, fine aggregate, coarse aggregate, and water, with or without admixtures.

**6.6.1** Concrete used in structures governed by this code shall have a minimum specified 28-day compressive strength of 5000 psi when containing liquids and 4000 psi for other reinforced concrete. Compressive strength shall be determined by testing cylinders at ambient temperature in accordance with ASTM C39 and 6.6.5.6.

**6.6.2** The maximum water-cementitious materials ratio ( $w/cm$ ) shall be 0.45.

**6.6.3** Concrete shall conform to the requirements of ACI 350 regarding constituents, testing, durability, concrete quality, mixing, and placing.

**6.6.4** Concrete shall be designed to have the following properties:

- a) Permeability in accordance with 6.6.5.8
- b) Fire resistance in accordance with 6.6.5.10
- c) Behavior at cryogenic temperature in accordance with 6.6.5
- d) Durability in accordance with 6.6.5.9

**6.6.5** *Cryogenic response of concrete*—The behavior of concrete at cryogenic temperature shall be included in the determination of the performance and integrity of the structure.

Protection of prestressing anchors should be provided. At elevated temperatures, the residual strength of the concrete wall should be assessed to ensure that collapse cannot occur if it is required to maintain its structural integrity and liquid contents. For prestressed concrete tank walls subject to fire effects, the most critical factor is usually the rate of temperature increase on an exposed surface. The use of intumescent coatings, or a sacrificial layer with mesh reinforcement, should be considered where excessive spalling could occur.

Sliding wall-to-base connections should be checked for their thermal properties. Where an elevated slab is used, the bearing capacity of piers supporting the tank base exposed to thermal radiation should also be checked. Reduction in strength of all materials exposed to elevated temperatures should be included in the design.

**R6.6—Concrete quality**

**R6.6.1** The concrete mixture should be designed to reduce the bulk water content such that internal ice formation, and hence internal cracking, is minimized. Air entrainment may be included to resist freezing-and-thawing conditions.

As a minimum, the following tests should be performed on the specified concrete:

- a) Compressive strength at an age specified by the designer under conditions similar to those at the job site
- b) Modulus of elasticity  $E_c$  (representative values at ambient and cryogenic temperatures)
- c) Coefficient of thermal expansion  $a_c$  (average value for the temperature range being considered)

The enhanced structural properties that are known to exist for concrete at low temperature are not generally used in design, except for the reduced coefficient of thermal expansion.

**R6.6.5** The values of the material properties listed in R6.6.5.3, R6.6.5.5, and R6.6.5.7 are typical values provided for reference. The engineer may use different values if verified

## CODE

**6.6.5.1** *Moisture content of concrete*—The expected moisture content of the concrete shall be included in the assessment of thermal conductivity, thermal deformation, permeability, specific heat, moisture migration, and the risk of freezing-and-thawing attack.

**6.6.5.2** *Thermal deformations*—The value for coefficient of thermal expansion/contraction of concrete for use in design shall be the value that is appropriate for the temperature range and moisture content range to be expected in service.

**6.6.5.3** *Thermal conductivity and specific heat*—The influence of moisture on the thermal conductivity  $K$  and specific heat  $c$  of the concrete shall be included in the design for hazard and other transient conditions that result in thermally-induced stresses.

## COMMENTARY

by tests on the specific mixture, or based on prior test data. (Refer to Marshall [1982], Krstulovic-Opara [2005, 2007], Hanaor and Sullivan [1983], Hanaor [1982], FIP [1982a, 1988], Elices and Sleigh [1978], Closner and Legatos [1978], Bruggeling [1978], Bamforth [1984], Bamforth et al. [1983], Whiteley et al. [1981], Rostasy [1988], Rostasy and Wiedemann [1981], Tarakada et al. [1981], Planas et al. [1978], Trotter et al. [1975], Suehiro and Nitta [1979], Rostasy and Wiedemann [1979, 1980], Lentz and Monfore [1966], Kasami et al. [1981], and Doi et al. [1974] for additional information on cryogenic behavior.)

**R6.6.5.1** Properties of concrete under cryogenic conditions are greatly affected by the moisture content. Saturated concrete can degrade due to expansion of water on freezing. Nevertheless, many properties of moist concrete, such as strength, stiffness, permeability, and moisture migration, can be enhanced at low temperatures. Generally these should not be used in design except where listed. The industry standard is to neglect these enhancements because: a) the concrete response at room temperature typically governs design; and b) it is conservative to neglect these enhancements because moisture content is highly variable and can change with such factors as age and environment.

Thermal gradients in concrete members result in water vapor migration towards colder areas. This can lead to an accumulation of water in the insulation if no liner is present, or formation of ice lenses behind a liner.

**R6.6.5.2** Down to approximately  $-5^{\circ}\text{F}$ , the coefficient of thermal expansion/contraction,  $a_c$ , of concrete does not vary significantly. Between approximately  $-5$  and  $-100^{\circ}\text{F}$ , an increasing proportion of the pore water in moist concrete freezes, which affects the thermal deformation of the concrete as the water expands on freezing. Below approximately  $-100^{\circ}\text{F}$  and down to approximately  $-330^{\circ}\text{F}$ , the coefficient of thermal expansion increases with decreasing temperature (Rostasy and Wiedemann 1981; Krstulovic-Opara 2005, 2007; Hirth 1982).

The coefficient of thermal expansion/contraction of concrete is greatly affected by the type of coarse aggregate within the concrete and by the moisture content. In the absence of sufficiently reliable existing information, testing may be required to determine the coefficient of thermal expansion/contraction for a particular concrete composition, moisture content, and temperature range.

A test method for coefficient of thermal expansion/contraction of concrete specimens is given in CRD-C 39-81. This method could be modified for use at low temperatures by the provision of suitable cold storage facilities for specimens.

**R6.6.5.3** Certain hazards and other transient conditions result in thermally-induced stresses that should be addressed in design. Such conditions include cool-down, in-tank fire, adjacent-tank fire, liquid spill, and hydrotest. These conditions require calculations using realistic values of thermal

## CODE

## COMMENTARY

**6.6.5.4 Creep and drying shrinkage**—Estimations of creep and drying shrinkage shall be based on the most probable values of such effects in service. The value of concrete creep coefficient for use in the design shall be that for ambient temperature determined in accordance with ASTM C512.

**6.6.5.5 Elastic modulus**—The modulus of elasticity  $E_c$  for concrete shall be permitted to be taken as specified in 8.5 of ACI 350. For concretes other than normalweight, lightweight, and heavyweight, the value of concrete elastic modulus for use in the design shall be that for ambient temperature determined in accordance with ASTM C469, except under conditions where underestimation of elastic modulus will adversely affect the design. When a higher elastic modulus affects stresses, this higher stiffness shall be used in design.

**6.6.5.6 Strength**—The  $f'_c$  and tensile concrete strength  $f'_{ct}$  for use in design shall be based on ambient temperature in accordance with ASTM C39 and ASTM C496, respectively.

**6.6.5.7 Poisson's ratio**—The design of concrete members shall consider the influence of Poisson's ratio  $\mu$  at ambient

conductivity  $K$  and specific heat  $c$ . Moisture influences the thermal conductivity and specific heat in proportion to the moisture content of the concrete. As temperature decreases, the thermal conductivity of concrete increases linearly and specific heat decreases.

The thermal conductivity of moist normalweight concrete increases from approximately 1.85 Btu ft/ft<sup>2</sup> h°F at 77°F to approximately 2.72 Btu ft/ft<sup>2</sup> h°F at -247°F.

The specific heat of normalweight concrete at ambient temperatures is commonly between 0.20 and 0.28 Btu/lb per °F. Specific heat can be determined by elementary methods of physics in accordance with ASTM D4611. Limited information is available for specific heat at lower temperatures (Hirth 1982).

**R6.6.5.4** The most probable value, rather than the upper-bound values of a variable, is used in assessing creep and drying shrinkage. Consideration of creep and drying shrinkage effects should be as per ACI 209R and ACI 209.1R. Creep in concrete decreases with decreasing temperature roughly in proportion to the decrease in elastic strain at low temperatures. Creep for normalweight concrete at -22°F is typically half that at ambient temperature (FIP 1981). Designing for creep and drying shrinkage at ambient temperature is typically a conservative approach.

**R6.6.5.5** Lightweight and normalweight concrete are defined as concretes with unit weights between 90 and 150 lb/ft<sup>3</sup>. The elastic modulus of moist concrete increases with decreasing temperatures, whereas the effect on oven-dried concrete is less pronounced.

It is generally conservative to design using specified ambient temperature values. Ambient temperature values may not provide the desired conservatism at cryogenic conditions under all design conditions; in which case, cryogenic properties should be used.

The elastic modulus of moist normalweight concrete increases by approximately 50 to 75 percent between 77 and -310°F.

**R6.6.5.6** Compressive and tensile strengths of moist concrete increase with decreasing temperatures, and oven-dried concrete exhibits minor strength gains at low temperatures. It is conservative to design using specified ambient temperature values.

The compressive and tensile strengths of air-dried normalweight concrete increase approximately 10 percent between 75 and -250°F, whereas the corresponding gains for moist concrete may be up to approximately 300 percent (FIP 1982a).

In addition, concrete at cryogenic temperatures is frequently subjected to tensile stresses as a result of restrained thermal contraction and therefore may not benefit from its increased compressive strength at low temperatures.

**R6.6.5.7** Values for  $\mu$  vary widely depending on moisture, concrete strength, and aggregate type (FIP 1982b; ACI



## CODE

temperature. Determination of  $\mu$  shall be based on the most probable value during service.

The design of concrete members shall include the effects of  $\mu$  determined at ambient temperature in accordance with ASTM C469.

**6.6.5.8 Permeability**—Concrete used for primary containment shall be designed with intrinsic permeability  $k$  to cryogenic fluids of not greater than  $10^{-18}$  m<sup>2</sup> unless it is demonstrated in the design of the structure that a greater value is acceptable or that a lower value is required.

**6.6.5.9 Durability**—The durability requirements given in ACI 350 shall be followed for the intended working life and environment to which the concrete will be exposed.

## COMMENTARY

209R). The most probable value during service, rather than the upper-bound values of the variables, should be used.

Limited data indicate that  $\mu$  for normalweight concrete can increase from approximately 0.17 at 68°F to 0.22 at −265°F.

**R6.6.5.8** For concrete components, where gas or moisture permeation is to be limited, tests should be performed in advance to determine the permeability of the concrete used for these components.

Intrinsic permeability is the portion of hydraulic conductivity that is representative of the properties of the porous medium alone, but not the fluid.

Intrinsic permeability can be determined using the techniques given in Hanaor (1982). The coefficient of hydraulic conductivity  $K$  (in units of length/time) is related to the coefficient of intrinsic permeability  $k$  (in units of length<sup>2</sup>) by the equation  $K = k\rho g/\mu$ , where  $\rho$  is the density of the fluid,  $\mu$  is the dynamic viscosity of the fluid, and  $g$  is the gravitational constant.

There are inherent technical difficulties (Hanaor 1982, 1985; Hanaor and Sullivan 1983) that include, in particular, achievement of a good seal around the test specimen at such low temperatures. The moisture content of the concrete at the time of test should reflect, as far as possible, the expected moisture content of the concrete in service but should not be higher. Results obtained on specimens dried to lower moisture contents will provide a conservative estimate. Note that the coefficient of hydraulic conductivity is related to, but different from, the coefficient of intrinsic permeability.

Limited information is available on the permeability of concrete to fluids at cryogenic temperatures, but it has been reported (Hanaor 1982, 1985; Hanaor and Sullivan 1983) that the permeability of even partially-dried concrete is approximately half that obtained at ambient temperature.

Intrinsic permeability of concrete will depend on its moisture state and, evidence suggests, the aggregate type in addition to those factors affecting permeability at ambient temperature—for example, water-cement ratio ( $w/c$ ), cement type, and maturity at time of test. Intrinsic permeability tests would typically employ nitrogen as the test fluid. A mathematical relationship can be employed to obtain the intrinsic permeability of other stored fluids from the test results obtained using nitrogen.

**R6.6.5.9** Adequate durability of the concrete, whether it is used as the primary or secondary container, is essential. In particular, design for adequate resistance to cycles of freezing and thawing (secondary containment), sulfate resistance, corrosion protection of metals (chloride ion penetration resistance), resistance to alkali-aggregate reaction, and resistance to chemicals and corrosive gases should be considered. Durability requirements can be found in ACI 350.

Where aggregates are suspected to alkali-reactive, they should be tested for potential reactivity using the mortar-bar tests, ASTM C227, ASTM C289, and ASTM C1260. Aggregates that do not indicate a potential for alkali reactivity or

## CODE

## COMMENTARY

**6.6.5.10 Fire resistance**—The concrete shall be designed to avoid explosive spalling.

**6.7—Shotcrete**

Unless otherwise permitted in this code, shotcrete shall be in accordance with ACI 506.2 and ACI 350.

**6.8—Coating design**

**6.8.1** If a coating is used on the primary (inner) container, its permeability shall be evaluated at cryogenic temperatures to conform to the requirements of 6.8.2 and 6.8.3.

**6.8.2** When a coating functions as a vapor barrier, the following shall apply:

- a) The maximum water vapor permeability shall be 0.00164 oz/ft<sup>2</sup> per 24 hours using ASTM E96 under the least favorable mean monthly temperature/humidity conditions for the climate conditions at the location of the project.
- b) The bond strength of the coating shall not be reduced after 3 months of immersion in product vapor.
- c) The coating shall not deteriorate due to reactions with concrete.
- d) Bond strength of coating to concrete shall exceed 145 psi determined in accordance with ISO 4624 or equivalent.
- e) The escape of vapor shall be considered acceptable when the permeability of coating to product vapor does not exceed 0.00033 oz/ft<sup>2</sup>/24 hours.
- f) The coating shall have sufficient flexibility to bridge calculated crack widths. The coating must be capable

reactive constituents based on petrographic examination may be used without further testing. The use of adequate amounts of supplementary cementing materials as a partial replacement of the portland cement generally mitigates the detrimental effects of alkali reactivity.

ACI 515.1R contains a chart that is useful in the evaluation of the chemical effects on concrete, rate of attack, and proper methods for mitigating exposure. PCA (1986) also provides guidance on various substances that attack concrete and protective systems for the concrete.

**R6.6.5.10** Descriptions of the fire exposure on liquid natural gas (LNG) tanks can be found in 7.8.7 of NFPA 59A along with methods of fire protection in Chapter 13 and Appendix A of the same document. That information can also be applied to refrigerated liquefied gas (RLG) tanks.

High-strength concrete can experience explosive spalling when subjected to fire. Some coarse aggregates, such as flint gravels, are more prone to spalling than others and the concrete design should select one with a high resistance. The incorporation of some types of polymer fibers can mitigate explosive spalling in high performance concrete (Bilodeau et. al 1997; Hoff 1998). Experimental evidence shows that the proportion of fibers required increases with the level of prestress.

**R6.7—Shotcrete**

Shotcrete design and construction should be as per ACI 506R, ACI 350, ACI 372R, and ACI 373R. The cryogenic behavior of high-quality shotcrete (for example, Core Grade 1 or 2 in ACI 506.2) can be regarded as equivalent to that of the equivalent conventional concrete.

**R6.8—Coating design**

**R6.8.1** The performance criteria for coatings on the primary container (inner) need to be more conservative than those for the secondary (outer) container.

**R6.8.2** Coatings should be tested to verify that they are acceptable for the intended service. The scale of testing should be selected so that testing is representative of the conditions experienced during long-term use. These include effect of concrete creep and shrinkage as well as load- and temperature-induced deformations.

Listed limits for polymeric coatings were adopted from BS EN 14620. Coatings should be alkali-resistant, as determined using ASTM D1647, ASTM E96, and ISO 4624 or other approved methods.

**CODE****COMMENTARY**

of spanning across a crack that is 1.2 times wider than the calculated design crack width at normal operation temperatures and at crack opening velocity equal to the maximum crack opening velocity to be expected during an operating basis earthquake (OBE) event. The test method shall be proposed by the contractor and approved by the licensed design professional.

**6.8.3** When coatings are required to retain liquids, additional tests shall be performed to assure that the coating does not degrade after splashing and 3 months of exposure to the liquid so as to still meet the requirements of 6.8.2.

**6.9—Metal components**

**6.9.1** Tensile stresses at service loads shall not exceed permissible strength determined from allowable stresses and weld joint efficiencies in API 620 for the design metal temperature determined in Section 4.8.

**6.9.2** Welding and testing of weldments shall be in accordance with API 620.

**6.9.3** If a design incorporates higher stress levels in materials than those in API 620 that exhibit a distinct ductile-to-brittle transition, the design stress levels and material strain loading rates shall be such that the material always exhibits ductile behavior under the most severe projected design conditions.

## CODE

## COMMENTARY

## CHAPTER 7—LOAD FACTORS

**7.1—General**

Load factors specified in this chapter shall be used in conjunction with strength reduction factors outlined in Table 7.1 and as defined in ACI 350 and ACI 318.

**Table 7.1—Strength reduction factors**

Stress type	Strength reduction factor $\phi$
Tension-controlled sections	0.90
Compression-controlled sections	
-with spiral reinforcement	0.70
-with other reinforcement	0.65
Shear and torsion	0.75
Bearing on concrete	0.65
Post-tensioned anchorage	0.85
Flexure without axial load where strand embedment is less than the development length	0.75
Strut-and-tie models	0.75

**7.2—Load factors for ultimate limit state of primary container**

The load factors used for the ultimate limit state (ULS) of the primary container shall be in accordance with those in Table 7.2.

**7.2.1 Dead loads  $D$** —The load factors shall be in accordance with those in Table 7.2.

**7.2.2 Prestressing loads  $P_f$ ,  $P_i$** —The load factors shall be in accordance with those in Table 7.2.

**7.2.2.1** A load factor of 1.0 shall be used for all prestressing loads except in the case of the anchorage zones. For post-tensioned anchorage zone design, a load factor of 1.2 shall

**R7.1—General**

The  $\phi$ -factor used in strut-and-tie models is taken equal to the  $\phi$ -factor for shear. The value of  $\phi$  for strut-and-tie models is applied to struts, ties, and bearing areas in such models.

**R7.2—Load factors for ultimate limit state of primary container**

**R7.2.1** The following applies under normal operation conditions and per ACI 350:

- The dead load factor of 1.4 should be used when dead loads are combined only with the product pressure.
- The dead load factor of 1.2 should be used for all other normal loading conditions in Eq. (9-2) to (9-5) of ACI 350.
- The dead load factor of 0.9 should be used when the dead load reduces the effect of other loads, as per ACI 350, Eq. (9-6) and (9-7).

The 1.2 factor for dead load for operating basis earthquake (OBE) loading is per ACI 350, Eq. (9-5), because it is assumed that the dead load will be combined with other operation loads such as settlement and live load. The 0.9 load factor is ACI 350, Eq. (9-6) and (9-7), when the higher dead load reduces the effect of other loads.

The 1.0 factor for dead load for safe shutdown earthquake (SSE), explosion, impact, and fire should be reduced to 0.9 when the higher dead load reduces the effect of other loads. The 0.9 load factor is consistent with ACI 350, Eq. (9-6) and (9-7), when the higher dead load reduces the effect of other loads.

**R7.2.2.1** As stated in ACI 318, the load factor of 1.2 applied to the maximum tendon jacking force represents a design load of approximately 113 percent of the specified prestressing steel yield strength, but not more than 96 percent

## CODE

## COMMENTARY

**Table 7.2—Load factors for ultimate limit state of primary concrete tank for single-, double-, and full-containment tank systems**

Loading condition		Normal loading conditions				Abnormal loading conditions					
		Construction	Installation	Testing and commissioning	Operation	Spill	Earthquake			Explosion and impact	Fire
							SPILL + SSE <sub>aft</sub>	OBE	SSE		
Loading types											
Dead loads		1.2 (0.9)	1.2 (0.9)	1.2 (0.9)	1.2/1.4 (0.9)	NA	NA	1.2 (0.9)	1.0 (0.9)	1.0 (0.9)	1.0 (0.9)
Prestressing loads	General	1.0	1.0	1.0	1.0	NA	NA	1.0	1.0	1.0	1.0
	At anchorage	1.2	1.2	1.2	1.2	NA	NA	NA	NA	NA	NA
Product pressure: vapor/gas/vacuum		—	—	1.2	1.2/1.4	NA	NA	1.2	1.0	1.0	1.0
Product pressure: liquid		—	—	1.2	1.2/1.4	1.2	1.2	1.2	1.0	1.0	1.0
Thermal and/or moisture	Normal	1.2	1.2	1.2	1.2	NA	NA	1.2	1.0	1.0	—
	Spill	—	—	—	—	NA	NA	—	—	—	—
	Fire	—	—	—	—	NA	NA	—	—	—	1.0
Construction and commissioning loads	Construction and operation loads	1.6	—	—	—	NA	NA	—	—	—	—
	Installation loads	—	1.2/1.4 (0.9)	—	—	NA	NA	—	—	—	—
	Tank testing loads	—	—	1.2	—	NA	NA	—	—	—	—
	Thermally-induced tank cooling and filling loads	—	—	1.2	—	NA	NA	—	—	—	—
Shrinkage		1.2	1.2	1.2	1.2	NA	NA	1.2	1.0	1.0	1.0
Creep		1.2	1.2	1.2	1.2	NA	NA	1.2	1.0	1.0	1.0
General live loads		1.6/0.5	1.6/0.5	1.6/0.5	1.6/0.5	NA	NA	1.6/0.5	1.0	1.0	—
Differential settlement		1.2	1.2	1.2	1.2	NA	NA	1.2	1.0	1.0	1.0
Environmental loads: wind		1.6/1.3	NA	NA	NA	NA	NA	—	—	—	NA
Environmental loads: other		1.6/0.5	NA	NA	NA	NA	NA	—	—	NA	—
Seismic loads	OBE	—	—	—	—	NA	NA	1.3	—	NA	—
	SSE	—	—	—	—	NA	NA	—	1.0	NA	—
Explosion and impact		—	—	—	—	NA	NA	—	—	1.0	—
Fire		—	—	—	—	NA	NA	—	—	—	1.0

be applied to the maximum prestressing steel jacking force, as per ACI 350.

**7.2.2.2** Time-dependent effects (relaxation, creep, and shrinkage) on the structural system, as well as changing static systems caused by construction sequence, shall be included in the design.

**7.2.3** *Product pressure F*—The load factors shall be in accordance with those in Table 7.2.

of the nominal ultimate strength of the prestressing steel. This compares well with the maximum attainable jacking force, which is limited by the anchor efficiency factor.

**R7.2.2.2** Time-dependent effects, such as differential shrinkage caused by casting the wall after the slab, and casting the roof after the wall, should be accounted for in the design.

An example of a changing static system is casting the roof subsequent to circumferential post-tensioning of the wall. In this case, creep causes a portion of the post-tensioning force to redistribute into the roof, thereby causing increased force in the roof and decreased circumferential force in the wall.

**R7.2.3** The 1.2 load factor for product load under testing/commissioning and operation conditions is per ACI 350, Eq. (9-2) and (9-5). The 1.4 load factor, applied when product pressure is combined only with the dead load, is per ACI 350, Eq. (9-1).

During the testing and commissioning phase, the product denotes liquid used in hydrostatic testing. The 1.2 load factor for the OBE loading condition is consistent with ACI 350, Eq. (9.2) and (9.5).

## CODE

**7.2.4** *Thermal, moisture, or both* ( $T_e$ ,  $T_o$ )—The load factors shall be in accordance with those in Table 7.2.

**7.2.5** *Construction and commissioning loads* ( $L_{cn}$ ,  $L_{cm}$ )—The load factors shall be in accordance with those in Table 7.2.

**7.2.6** *Shrinkage*  $T_s$ —The load factors shall be in accordance with those in Table 7.2.

**7.2.7** *Creep*  $T_c$ —The load factors shall be in accordance with those in Table 7.2.

**7.2.8** *General live loads*  $L$ —The load factor for the general live loads, as defined in 5.1.10, shall be permitted to be reduced to 0.5 when it can be justified that no greater than 50 percent of the design live load is expected to be present during normal operating conditions, as per ACI 350, Section 9.2.1(a).

**7.2.9** *Differential settlement*  $T_{ds}$ —The load factors shall be in accordance with those in Table 7.2.

**7.2.10** *Environmental loads*  $E$ —The load factors shall be in accordance with those in Table 7.2.

**7.2.10.1** *Wind*  $W$ —The load factors shall be in accordance with those in Table 7.2.

**7.2.10.2** *Other*—The load factors shall be in accordance with those in Table 7.2.

## COMMENTARY

**R7.2.4** The 1.2 load factor for all normal thermal effects is per ACI 350, Eq. (9-2). For the OBE, the 1.2 load factor is per ACI 350, Eq. (9-2) and (9-5).

**R7.2.5** Construction loads are categorized as live loads. The load factor of 1.6 is per ACI 350, Eq. (9-2). Installation loads are better defined and less variable than construction loads, and are treated as dead loads per ACI 350, Eq. (9-1). The 0.9 load factor is consistent with ACI 350, Eq. (9-6) and (9-7), when higher installation loads reduce the effect of other loads.

Testing and commissioning loads are controlled and monitored and, as such, are treated as dead loads. The load factor of 1.2 is per ACI 350, Eq. (9-2), because they are combined with thermal loads. The abnormal loading conditions are not applicable to construction and commissioning.

**R7.2.6** For normal loading conditions, ACI 350 includes shrinkage under “T” type loading and, as per Eq. (9-2), the load factor when combined with other loadings is 1.2. For the OBE, the 1.2 load factor is used in combination with other loads as per ACI 350, Eq. (9-2).

**R7.2.7** For normal loading conditions, ACI 350 includes creep under “T” type loading and, as per Eq. (9-2), the load factor when combined with other loadings is 1.2. For the OBE, the 1.2 load factor is used in combination with other loads as per ACI 350, Eq. (9-2).

**R7.2.8** For general live loads (for example, piping loads) under normal loading conditions as well as for an OBE earthquake, a load factor of 1.6 is used, as per ACI 350, Eq. (9-2). For the SSE, the 1.0 load factor is used in combination with other loads, as per ACI 350, Eq. (9-5).

**R7.2.9** For normal loading conditions, as well as OBE, a load factor of 1.2 is used as per ACI 350, Eq. (9-2).

**R7.2.10.1** Wind load effects may apply to either the primary or secondary container, depending on which is constructed first or constructed in parallel. Shielding of the primary (inner) container by the secondary (outer) container may be considered.

When directionality effects have been included in calculating wind loads, a load factor of 1.6 should be used per ACI 350, Eq. (9-4) and (9-6). When directionality effects have not been considered in nonhurricane regions, a load factor of 1.3 can be used per ACI 350, Section 9.2.1(a).

**R7.2.10.2** Other environmental load effects (for example, solar radiation, snow, and rain), may apply to either the primary or secondary container, depending on which is constructed first or if the containers are constructed in

**CODE**

**COMMENTARY**

**7.2.11 Seismic loads** ( $E_o$ ,  $E_s$ )—The load factors shall be in accordance with those in Table 7.2.

**7.2.12 Explosion and impact** ( $B$ ,  $M_i$ )—The load factors shall be in accordance with those in Table 7.2.

**7.2.13 Fire**  $H$ —The load factors shall be in accordance with those in Table 7.2.

The load factors used for the ULS of the secondary container shall be in accordance with Table 7.3.

**7.3—Load factors for ultimate limit state of secondary container**

**7.3.1 Dead loads**  $D$ —The load factors shall be in accordance with those in Table 7.3.

**7.3.2 Prestressing loads** ( $P_f$ ,  $P_i$ )—A load factor of 1.0 shall be used for all prestressing loads, except in the case of the anchorage zones. For post-tensioned anchorage zone design, a load factor of 1.2 shall be applied to the maximum prestressing steel jacking force, as per ACI 350.

parallel. Shielding of the primary (inner) by the secondary (outer) container may be considered.

For other environmental loads, a load factor of 1.6 should be used per ACI 350, Eq. (9-3), for normal loading conditions. When wind effects are considered together with other environmental loads, the load factor can be reduced to 0.5, as per ACI 350, Eq. (9-4).

**R7.2.11** Following current RLG tank practices, this code uses two levels of earthquake: OBE and SSE. For the OBE condition, a load factor of 1.3 should be used. For the SSE condition, a load factor of 1.0 should be used.

**R7.2.12** Explosion and impact loads generally have little or no effect on the primary tank of a double wall tank. Depending on the foundation-structure interaction, however, the response of the entire structure may induce forces in the primary container.

**R7.2.13** There are generally no requirements for fire, so a load factor of 1.0 should be used where needed.

**R7.3—Load factors for ultimate limit state of secondary container**

- R7.3.1** Under normal operation conditions and per ACI 350:
- a) The dead load factor of 1.4 should be used when dead loads are combined only with the product pressure;
  - b) The dead load factor of 1.2 should be used for all other normal loading conditions in Eq. (9-2) to (9-5) of ACI 350; and
  - c) The dead load factor of 0.9 should be used when the dead load reduces the effect of other loads, as per ACI 350, Eq. (9-6) and (9-7).

The 1.0 load factor for the spill and the spill + SSE<sub>aff</sub> event should be reduced to 0.9 when the higher dead load reduces the effect of other loads. The 0.9 load factor is consistent with ACI 350, Eq. (9-6) and (9-7).

The 1.2 load factor for the OBE loading is consistent with ACI 350, Eq. (9-5), because it is assumed that the dead load will be combined with other operation loads such as settlement and live load. The 0.9 load factor is consistent with ACI 350, Eq. (9-6) and (9-7), when the higher dead load reduces the effect of other loads.

The 1.0 load factor for the SSE, explosion, impact, and fire should be reduced to 0.9 when the higher dead load reduces the effect of other loads. The 0.9 load factor is consistent with ACI 350, Eq. (9-6) and (9-7), when the higher dead load reduces the effect of other loads.

**R7.3.2** The load factor of 1.2 applied to the maximum tendon jacking force represents a design load of approximately 113 percent of the specified prestressing steel yield strength, but not more than 96 percent of the nominal ultimate strength of the prestressing steel. This compares well

## CODE

## COMMENTARY

Table 7.3—Load factors for ULS of secondary concrete tank

Loading conditions		Normal loading conditions				Abnormal loading conditions					
		Construction	Installation	Testing and commissioning	Operation	Spill	Earthquake			Explosion and impact	Fire
							Spill + SSE <sub>aft</sub>	OBE	SSE		
Dead loads		1.2 (0.9)	1.2 (0.9)	1.2 (0.9)	1.2/1.4 (0.9)	1.0 (0.9)	1.0 (0.9)	1.2 (0.9)	1.0 (0.9)	1.0 (0.9)	1.0 (0.9)
Prestressing loads	General	1.0	1.0	1.0	1.0	1.0	1.0	1.0	1.0	1.0	1.0
	At anchorage	1.2	1.2	1.2	1.2	NA	NA	NA	NA	NA	NA
Product pressure: vapor/gas/vacuum		—	—	1.2	1.2/1.4	1.0 (0.0)	1.0 (0.0)	1.2	1.0	1.0	1.0
Product pressure: liquid		—	—	—	—	1.0	1.0	—	—	—	1.0
Thermal and/or moisture	Normal	1.2	1.2	1.2	1.2	—	—	1.2	1.0	1.0	—
	Spill	—	—	—	—	1.0	1.0	—	—	—	—
	Fire	—	—	—	—	—	—	—	—	—	1.0
Construction and commissioning loads	Construction and operation loads	1.6	—	—	—	—	—	—	—	—	—
	Installation loads	—	1.2/1.4 (0.9)	—	—	—	—	—	—	—	—
	Tank testing loads	—	—	1.2	—	—	—	—	—	—	—
	Thermally-induced tank cooling and filling loads	—	—	1.2	—	—	—	—	—	—	—
Shrinkage		1.2	1.2	1.2	1.2	1.0	1.0	1.2	1.0	1.0	1.0
Creep		1.2	1.2	1.2	1.2	1.0	1.0	1.2	1.0	1.0	1.0
General live loads		1.6/0.5	1.6/0.5	1.6/0.5	1.6/0.5	—	—	1.6/0.5	1.0	1.0	—
Differential settlement		1.2	1.2	1.2	1.2	1.0	1.0	1.2	1.0	1.0	1.0
Environmental loads: wind		1.6/1.3	1.6/1.3	1.6/1.3	1.6/1.3	—	—	—	—	—	—
Environmental loads: other		1.6/0.5	1.6/0.5	1.6/0.5	1.6/0.5	—	—	—	—	—	—
Seismic loads	OBE	—	—	—	—	—	—	1.3	—	—	—
	SSE	—	—	—	—	—	—	—	1.0	—	—
	SSE <sub>aft</sub>	—	—	—	—	—	1.0	—	—	—	—
Explosion and impact		—	—	—	—	—	—	—	—	1.0	—
Fire		—	—	—	—	—	—	—	—	—	1.0

Time-dependent effects (relaxation, creep, and shrinkage) on the structural system, as well as changing static systems caused by construction sequence, shall be included in the design.

**7.3.3 Product pressure F**—The load factors shall be in accordance with those in Table 7.3.

with the maximum attainable jacking force, which is limited by the anchor efficiency factor.

Time-dependent effects, such as differential shrinkage caused by casting the wall after the slab and roof, should be accounted for in the design.

An example of a changing static system is casting the roof subsequent to circumferential post-tensioning of the wall. In this case, creep causes a portion of the post-tensioning force to redistribute into the roof, causing increased force in the roof and decreased circumferential force in the wall.

**R7.3.3** The 1.2 load factor for product pressure under testing/commissioning and operation conditions is per ACI 350, Eq. (9-2) and (9-5). The 1.4 load factor, applied when product pressure is combined only with the dead load, is per ACI 350, Eq. (9-1).

In the case of positive pressure from vapor or gas occurring during the spill and the spill + SSE<sub>aft</sub> event, the 1.0 load factor should be used. Due to vapor generation during a spill, negative pressure from vacuum is not a credible event during the spill and the spill + SSE<sub>aft</sub> event. Therefore, the



**CODE**

**COMMENTARY**

**7.3.4 Thermal and/or moisture** ( $T_e$ ,  $T_o$ )—The load factors shall be in accordance with those in Table 7.3.

**7.3.5 Construction and commissioning loads** ( $L_{cn}$ ,  $L_{cm}$ )—The load factors shall be in accordance with those in Table 7.3.

**7.3.6 Shrinkage**  $T_s$ —The load factors shall be in accordance with those in Table 7.3.

**7.3.7 Creep**  $T_c$ —The load factors shall be in accordance with those in Table 7.3.

**7.3.8 General live loads**  $L$ —The load factor for the general live loads, as defined in 5.1.10, shall be permitted to be reduced to 0.5 when it can be justified that no greater than 50 percent of the design live load is expected to be present during normal operating conditions, as per ACI 350, Section 9.2.1(a).

**7.3.9 Differential settlement**  $T_{ds}$ —The load factors shall be in accordance with those in Table 7.3.

**7.3.10 Environmental loads**  $E$

**7.3.10.1 Wind**  $W$ —The load factors shall be in accordance with those in Table 7.3.

**7.3.10.2 Other**—The load factors shall be in accordance with those in Table 7.3.

load factor should be reduced to zero for vacuum loading. The 1.2 load factor for the OBE loading condition is per ACI 350, Eq. (9-2) to (9-5).

**R7.3.4** The 1.2 load factor for all normal thermal effects is per ACI 350, Eq. (9-2).

**R7.3.5** Construction loads are categorized as live loads. The load factor of 1.6 is per ACI 350, Eq. (9-2). Installation loads are better defined and less variable than construction loads, and are treated as dead loads per ACI 350, Eq. (9-1). The 0.9 load factor is consistent with ACI 350, Eq. (9-6) and (9-7), when higher installation loads reduce the effect of other loads.

Testing and commissioning loads are controlled and monitored and, as such, are treated as dead loads. The load factor of 1.2 is per ACI 350, Eq. (9-2), because testing and commissioning loads are combined with thermal loads. Abnormal loading conditions are not applicable to construction and commissioning.

**R7.3.6** For normal loading conditions, ACI 350 includes shrinkage under T-type loading and, as per Eq. (9-2), the load factor, when combined with other loadings, is 1.2. For the OBE, the 1.2 load factor is used in combination with other loads as per ACI 350, Eq. (9-2).

**R7.3.7** For normal loading conditions, ACI 350 includes creep under T-type loading and, as per Eq. (9-2), the load factor, when combined with other loadings, is 1.2. For the OBE, the 1.2 load factor is used in combination with other loads as per ACI 350, Eq. (9-2).

**R7.3.8** For general live loads, as defined in 5.1.10 (for example, piping loads) under normal loading conditions as well as for an OBE earthquake, a load factor of 1.6 is used, as per ACI 350, Eq. (9-2). General live loads are not required to be combined with abnormal loadings.

**R7.3.9** For normal loading conditions, as well as OBE, a load factor of 1.2 is used as per ACI 350, Eq. (9-2).

**R7.3.10.1** Where wind loads have been reduced by a directionality factor, a load factor of 1.6 should be used per ACI 350, Eq. (9-4) and (9-6). Where wind loads have not been reduced by a directionality factor, a load factor of 1.3 can be used, per ACI 350, Section 9.2.1(b). Wind loads are not required to be combined with abnormal loadings.

**R7.3.10.2** For other environmental loads, such as solar radiation, snow, and rain, a load factor of 1.6 should be used per ACI 350, Eq. (9-3), for normal loading conditions. When wind effects are considered together with other environmental loads, the load factor can be reduced to 0.5 per ACI

## CODE

## COMMENTARY

**7.3.11** *Seismic loads* ( $E_o$ ,  $E_s$ )—The load factors shall be in accordance with those in Table 7.3.

**7.3.12** *Explosion and impact* ( $B$ ,  $M_i$ )—The load factors shall be in accordance with those in Table 7.3.

**7.3.13** *Fire*  $H$ —The load factors shall be in accordance with those in Table 7.3.

350, Eq. (9-4). Other environmental loads are not required to be combined with abnormal loadings.

**R7.3.11** Following current RLG tank practices, this code uses three levels of earthquake: OBE, SSE, and  $SSE_{aft}$ . For the OBE condition, a load factor of 1.3 should be used. For the SSE condition, a load factor of 1.0 should be used. For the spill +  $SSE_{aft}$  condition, a load factor of 1.0 should be used, as per ACI 350, Eq. (9-5).

**R7.3.12** There are generally no requirements for explosion and impact, so a load factor of 1.0 should be used where needed.

**R7.3.13** There are generally no requirements for fire, so a load factor of 1.0 should be used where needed.

## CODE

## COMMENTARY

## CHAPTER 8—ANALYSIS AND DESIGN

**8.1—Methods of analysis**

**8.1.1** *Required analysis*—The containment structure shall be analyzed as an integrated structure that includes the foundation, wall, roof, contained liquid, liner, or portion of the liner that is assumed to act compositely with the concrete structure. Constitutive models, assumed values, and details used in the analysis shall be approved by the owner/engineer.

**8.1.1.1** The effects of discontinuities shall be considered.

**8.1.1.2** For load conditions described in 5.1.15 and 5.1.16, which include severe thermal loading conditions, the structure shall be analyzed for the entire transient history up to and including steady state.

**8.1.1.3** Both maximum and minimum design ambient temperatures shall be used as the initial temperature profiles for the analysis of all loading conditions.

**8.1.1.4** The structural model for load conditions described in 5.1.15 and 5.1.16 shall consider the entire temperature time history and be analyzed on the basis of transient inelastic response.

**R8.1—Method of analysis**

**R8.1.1** The analysis of imposed mechanical loads, thermal loads, and support configurations that do not vary significantly in the circumferential direction can be analyzed using an axisymmetric dimensional model. For imposed mechanical loads, thermal loads, and support configurations that do vary in the circumferential direction, a three-dimensional or two-dimensional axisymmetric harmonic analysis should be performed.

The effect of soil stiffness should be included in the analysis as defined in 8.1.2.

For load conditions described in 5.1.15 and 5.1.16, which include severe thermal loading conditions, the structure should be analyzed for the entire transient history up to and including steady state. Both maximum and minimum design ambient temperatures should be used as the initial temperature profiles for the analysis of all loading conditions. For the load condition described in 5.1.15, the temperature for the entire structure, including the roof, should be estimated. The temperature resulting from vapor generation during spill events should be taken into account.

The structural model for load conditions described in 5.1.15 and 5.1.16 should consider the entire temperature time history and be analyzed on the basis of transient inelastic response. Serviceability requirements should be checked both during the transient and steady-state temperature profiles. The analysis for these thermal load conditions should take into account the effect of cracking and tension stiffening.

**R8.1.1.1** Consideration should also be given to the presence of structural discontinuities causing local stresses that are in addition to the global stress fields determined from a two-dimensional axisymmetric analysis. In particular, local discontinuities should be considered in the circumferential direction at tendon anchorage buttresses, and in the vertical direction at the buttress-to-slab connection.

**R8.1.1.2** For solar radiation and temperature loading, a two-dimensional axisymmetric model is sufficient for determination of global loads.

**R8.1.1.3** All temperature variations should be based on 95th and 5th percentile temperatures. Additionally, the corresponding effects of solar radiation should be incorporated within all thermal-related analyses, including those for normal and spillage load cases.

**R8.1.1.4** Stress-free temperatures should be taken as an upper and lower bound within the analysis adequately reflecting the construction period and historical data. Heat-transfer analysis should be performed using film coefficients for air based on tank size, air-flow conditions, and tank surface temperatures.

## CODE

**8.1.1.5** Unless otherwise specified, the outside vertical tank surface of the secondary container shall be considered as a cylinder in cross flow subjected to a coincident wind speed that is exceeded at least 95 percent of the time based on recorded data for the area. In no case shall the coincident wind speed be taken greater than 13 ft/s.

**8.1.1.6** The tank roof shall be considered as a flat plate with due allowance for the effects of the dome shape in a wind speed flow of 13 ft/s.

**8.1.1.7** Cracking and tension stiffening shall be included by appropriate modification of the material stress-strain relationship or by the use of finite elements that have the capability of cracking under tension and crushing under compression, as well as the ability to include reinforcing steel.

**8.1.1.8** The cracking analysis shall be based on a finite element method that uses recognized or codified constitutive models for the stress strain behavior of concrete and incorporates tension-stiffening effects. When calculating calculated crack widths, the tension stiffening term shall not be deducted from the calculation where tension stiffening is explicitly included in the analysis. Additionally, the calculated crack widths shall be calculated as characteristic and not mean calculated crack widths.

Unless otherwise specified, the concrete constitutive model from BS EN 1992-1-1 shall be used for determining calculated crack widths.

**8.1.1.9** Three-dimensional analysis shall be used to determine the effects of post tensioning sequence on the outer tank local to and within the access opening unless justified by alternative methods. Emphasis shall be placed on the stress state within the access opening due to the absence of self-weight in this area. The state of stress determined by this analysis shall comply with the minimum performance requirements of Chapter 6.

**8.1.1.10** Where assumptions are made to simplify the level of analysis—for instance, where pile groups are simplified from three-dimensional orthogonal/radial behavior to axisymmetric behavior—then verification shall be carried out to ensure that the analysis assumptions capture and bind the actual behavior.

**8.1.1.11** Serviceability requirements shall be checked both during the transient and steady-state temperature profiles. The analysis for these thermal load conditions shall take into account the effect of cracking and tension stiffening.

## COMMENTARY

**R8.1.1.5** A wind speed of 13 ft/s is a value historically used in the design, and is considered good practice.

**R8.1.1.8** BS EN 1992-1-1 is recommended for determining calculated crack widths. In this case, the calculated crack widths are characteristic and not mean calculated crack widths. Extensive field experience with liquid-retaining and offshore concrete structures has demonstrated that satisfactory liquid tightness and liquid-retaining performance can be achieved by imposing calculated crack width limits.

It should be noted, however, that calculated crack width represents an average numerical value that is not directly equivalent to calculated crack width measured in the field. Due to the nonhomogeneous nature of concrete, calculated crack width values measured in the field will vary from calculated values and, therefore, they cannot be directly compared to calculated crack widths.

## CODE

## COMMENTARY

**8.1.2** *Soil and pile stiffness*

**8.1.2.1** For any analysis of the structure that includes either the static soil/pile stiffness (short-term or long-term settlement) or dynamic soil/pile stiffness, the analysis shall include a practical lower- and upper-bound range of soil properties.

**8.1.2.2** The range of soil stiffness shall be included as part of the geotechnical investigation and determined by the geotechnical engineer.

**8.1.2.3** When established by the geotechnical investigation, nonlinear soil properties, nonlinear pile stiffness, or both, shall be included in the static and dynamic analysis of the structure.

**8.1.2.4** The range of values of soil properties shall be defined by the geotechnical engineer based on the soil investigation.

**8.1.3** *Seismic analysis***8.1.3.1** *General*

**8.1.3.1.1** The seismic analyses of the refrigerated liquefied gas (RLG) tank foundation system shall be performed for the operating basis earthquake (OBE), safe shutdown earthquake (SSE), and safe shutdown earthquake aftershock (SSE<sub>aft</sub>) events. The effect of tank wall flexibility shall be considered in these analyses.

**8.1.3.1.2** Selected methods shall be approved by the engineer. If the design of an RLG tank is based on linear analysis, the response modification factor  $R$  shall be taken as 1.0—that is, no reduction in seismic forces are permitted.

Results of nonlinear dynamic or nonlinear static (pushover) analyses shall be used provided the peak strains in concrete and steel do not exceed the limiting values prescribed in this code. Nonlinear analysis shall be carried out with true best estimates of demand (load) and strength without any load reduction or material safety factors. All responses (for example, plastic yielding, base uplifting, and base sliding) shall be explicitly calculated in the nonlinear analysis.

**R8.1.2.1** Guidance for selecting material property values used in the analysis is provided in ASCE 4. For slab-on-ground foundations, the range of dynamic soil stiffness need not exceed twice the mean value for the upper bound or one-half the mean value for the lower bound.

For pile foundations, to account for the variable soil properties and mechanism for developing resistance, an equivalent range of 100 percent greater than the unfactored stiffness and a lower bound of 50 percent of the unfactored stiffness is accepted practice (Malhotra 1995).

**R8.1.3.1.2** Both linear and nonlinear analyses can be used to determine the seismic forces. The design of a RLG tank should be based on a linear analysis with a force reduction factor  $R = 1$ . Historically, linear analysis is used in the case of low seismic regions, an OBE case, or both, whereas nonlinear analysis is used in regions with higher seismicity, SSE, or both.

Results of nonlinear dynamic or nonlinear static (pushover) analyses may be used provided the peak strains in concrete and steel do not exceed the limiting values prescribed in this code. Nonlinear analysis should be carried out with true estimates of demand (load) and strength without any load reduction or material safety factors. All responses (for example, plastic yielding, base uplifting, and base sliding) should be explicitly calculated in the nonlinear analysis.

Guidance for selecting modeling methodologies, material properties, and other values used in the analysis is provided in Malhotra (1995).

## CODE

## COMMENTARY

**8.1.3.1.3** The reduction of responses due to soil-structure interaction (SSI) effects shall be permitted, but limited to a maximum reduction of 50 percent for SSE analysis and 40 percent for SSE<sub>aft</sub> and OBE analyses.

**8.1.3.2** *Seismic analysis methods*

**8.1.3.2.1** The response spectrum or time history analysis method shall be used for calculating the seismic responses of the tank-fluid-foundation system. The time histories shall meet the amplitude, frequency, and duration requirements for the site for OBE, SSE, and SSE<sub>aft</sub> events.

**8.1.3.2.2** Both horizontal and vertical ground motions, defined either as response spectra or time histories, shall be considered in the seismic analysis.

**8.1.3.3** *Finite element model of tank-fluid-foundation system*

**8.1.3.3.1** The finite element model of a tank-fluid foundation system shall include the liquid content, inner tank, outer tank, roof, and soil/pile foundation (for soil-structure interaction [SSI] effects).

**8.1.3.3.2** For determining the dynamic foundation impedances for the SSI analysis, strain-compatible dynamic soil properties shall be used.

**8.1.3.3.3** When the analysis is performed without the SSI effect, the tank-fluid model shall be permitted to be constructed in accordance with ACI 350.3.

**R8.1.3.2.1** The modal superposition method is used for response spectrum analysis. For time history analysis, the modal superposition or direct integration method can be used for calculating the seismic responses (MCEER 2001; Malhotra 1995; Veletsos 1984).

**R8.1.3.2.2** Section R5.1.13 of this code describes how and where these ground motions are to be determined. When the tank is located in a high seismic region, and is susceptible to partial uplifting at the base, the seismic analysis may include the nonlinear effects due to base uplifting (Housner 1982).

**R8.1.3.3.1** Where stick models are used as the basis for seismic analysis, the member axial, bending, and shear stiffnesses are used to construct the detailed finite element models of the tank-fluid-foundation system. The steel roof and suspended deck, where applicable, should be modeled with the outer tank to account for the dynamic amplification of the accelerations.

Detailed procedures for developing a stick model are discussed in the literature (Veletsos 1984; Malhotra et al. 2000; Richart et al. 1970). The impulsive and convective masses with the associated spring constants are lumped at appropriate heights on the inner tank stick model. The hydrodynamic forces due to seismic excitation are the combination of the impulsive and convective forces.

**R8.1.3.3.2** The dynamic foundation impedances for the SSI analysis and strain-compatible dynamic soil properties are described in MCEER (2001) and ASCE/SEI 7. Service from the geotechnical consultant is required.

Consideration of the SSI effect will increase the effective vibration period of the tank-fluid-foundation system, and generally the overall system damping. Thus, the seismic forces will be reduced. A simple and practical approach for calculating the effective vibration period and system damping for SSI consideration is presented in Lysmer et al. (1981). For a complex dynamic soil-pile-tank foundation interaction problem, the seismic response may be determined based on the finite element seismic analysis method (U.S. NRC 1973).

**CODE**

**COMMENTARY**

**8.1.3.4 Damping consideration and seismic analysis**

**8.1.3.4.1** The seismic analysis of the tank-fluid-foundation system shall take into account damping expressed as a percentage of critical damping.

**8.1.3.4.2** Types of damping considered in seismic analysis shall include:

- a) Structural damping
- b) Convective damping
- c) Foundation damping (in conjunction with an SSI analysis)
- d) System (or composite modal) damping

**8.1.3.4.3** Structural damping values provided in Table 8.1.3.4.3 shall be used unless higher values can be justified through tests or reference.

**Table 8.1.3.4.3—Structural damping**

Tank type	OBE	SSE
Reinforced concrete	4 percent	7 percent
Prestressed concrete	2 percent	5 percent
Steel	2 percent	4 percent

Note: Structural damping values were obtained from ACI SP-209 (Malhotra 2002).

**8.1.3.4.4** The damping for convective (sloshing) action shall be 0.5 percent of critical.

**8.1.3.4.5** The foundation damping for any vibration mode shall not exceed 25 percent of critical.

**8.1.3.4.6** The system damping for any vibration modes shall not exceed 15 percent for operating basis earthquake (OBE) and safe shutdown earthquake aftershock ( $SSE_{aft}$ ), and 20 percent for safe shutdown earthquake (SSE).

**8.1.3.4.7** The horizontal and vertical acceleration response spectra defined in 5.1.13 of this code shall be constructed covering the entire range of anticipated damping ratios and natural periods of vibration, including the sloshing (convective) mode of vibration.

**8.1.3.4.8** The impulsive, convective, and all other significant modal responses shall be combined by the square root of sum of squares (SRSS) method. The total horizontal and vertical responses shall be combined by the (1-0.3-0.3) rule for the three orthogonal directions.

**R8.1.3.4.1** When the tank foundation can be considered as fixed-base (shear wave velocity greater than or equal to 2500 ft/s), only the structural and convective damping values are used in the seismic analysis.

**R8.1.3.4.2** Structural damping is related to the type of tank material. Because the impulsive liquid moves with the structure, impulsive damping is a type of structural damping.

**R8.1.3.4.4** Convective (fluid) damping is associated with sloshing response of the liquid.

Only the impulsive mode is included in the evaluation of the system damping for a tank-fluid-foundation system. The convective (sloshing) mode that exhibits a very long period of vibration is considered as decoupled from the impulsive mode.

**R8.1.3.4.5** The radiation and viscous damping for soil/pile foundation should be considered in SSI analysis. The foundation radiation damping is a function of the excitation frequency. The excitation frequency can be assumed equal to the natural frequency of the first impulsive mode of vibration of the tank, and can be evaluated based on MCEER (2001) and ASCE/SEI 7.

**R8.1.3.4.6** In the SSI model, with different damping values in tank-fluid-foundation systems, the system damping (or composite modal damping) should be calculated for each vibration mode for determining the dynamic modal responses.

**CODE****COMMENTARY**

**8.1.3.4.9** The OBE, SSE, and  $SSE_{aft}$  seismic responses such as accelerations, member forces, and moments shall be combined with other applicable static loads for design of inner and outer concrete tank and foundation.

**8.1.3.4.10** For design of suspended deck, steel roof, and other equipment supported at the roof, the maximum seismic acceleration response of the roof at the appropriate radiuses shall be required.

**8.2—Design basis****8.2.1** *General*

**8.2.1.1** Concrete and prestressed concrete containers, associated concrete structures, and components of the structures shall be proportioned to have design strengths at all sections equal to or exceeding the minimum required strengths calculated for the factored loads and forces in such combinations as specified in Chapter 5.

**8.2.1.2** Design of prestressed concrete containers shall be based on strength and serviceability requirements at all load stages throughout construction and the life of the structure.

**8.2.1.3** The design of the concrete and prestressed concrete containment shall be in accordance with the provisions of ACI 350 except as otherwise modified or supplemented in this code.

**8.2.2** *Required strength*—The required strength to resist the loads specified in 5.1 shall be at least equal to the resultant factored load for the load combinations prescribed in 5.2 combined with the load factors defined in Tables 7.2 and 7.3.

**8.2.3** *Design strength*—The design strength provided by a member or cross section shall be taken as the product of the nominal strength calculated in accordance with the provisions of this code and multiplied by the applicable strength reduction factor specified in Table 7.1.

**8.2.4** *Serviceability requirements*—The container shall be designed to meet or exceed the serviceability requirements prescribed in Chapter 6.

**8.3—Foundation design**

Requirements for the foundation slab are different from those for a liquid-tight slab because the secondary bottom provides a leak-tight barrier that protects the slab from the effects of the spilled product.

**8.3.1** The foundation shall be constructed of concrete with a  $f'_c$  of 4000 lb/in.<sup>2</sup>

**8.3.2** Slab foundations not in contact with refrigerated liquefied gas (RLG) and the associated temperatures shall have a minimum thickness of 12 in.

**R8.2—Design basis**

**R8.2.1.1** The objective of the container design is to ensure that the container meets all the performance criteria prescribed in Chapter 6 of this code, both during normal and abnormal load conditions.

**R8.2.1.2** While the design is primarily based on the strength design method, a number of loading conditions (particularly those associated with abnormal loads) are also required to comply with serviceability.

**R8.3—Foundation design**



**CODE**

**COMMENTARY**

**8.3.2.1** The minimum reinforcement, cover, and bar spacing shall be in accordance with ACI 350.

**8.3.3** Slab foundations in contact with RLG shall have a minimum thickness of 12 in.

**8.3.3.1** The ratio of minimum reinforcement area to gross concrete area shall be at least 0.006 in each direction. Gross concrete area for calculating minimum reinforcement shall be based on the smaller of actual slab thickness or 24 in. Minimum reinforcement shall be distributed as follows:

- a) Not less than 2/3 of the required area in the upper layer
- b) Not less than 1/3 of the required area in the bottom layer

**8.3.3.2** The upper layer of reinforcement shall be located in the top 3.0 in. of the slab. The lower mat of reinforcement shall be located in the bottom 5 in. of the slab.

**8.3.3.3** The maximum bar spacing shall not exceed 12 in. and the minimum bar size shall be No. 4.

**8.3.4** Structural slabs and pile caps shall be designed and detailed in accordance with ACI 350.

**8.3.5** When seismic loads dictate that anchors are required to resist the inner tank seismic overturning loads, the slab or pile cap shall be designed to resist the pullout yield strength of the anchors.

**8.3.6** The operating basis earthquake (OBE) and safe shut-down earthquake (SSE) anchor loads shall not include any inelastic behavior of the inner tank, inner tank anchors, or other components that reduce the anchor loads.

**8.3.7** If the slab or pile cap is thickened at the outside circumference, additional reinforcing shall be added to maintain the minimum reinforcing ratio reinforcement specified in 8.3.2.1 or 8.3.3.1.

**8.3.8** When a monolithic wall-to-foundation joint is incorporated in the design, the effect of wall stiffness and forces shall be included in the analysis of the slab for the predicted differential settlements.

**8.3.9** Reinforcing shall be continuous through construction joints in the slab.

**8.3.10** All reinforcing shall be fully developed.

**8.3.11** Development lengths and lap lengths shall be in accordance with ACI 350.

**8.4—Wall design**

**8.4.1** The tank wall shall be constructed of concrete with a minimum  $f'_c$  of 5000 lb/in.<sup>2</sup>

**R8.3.5** The pullout strength of the anchor, the flexural resistance of the slab, and pile cap punching shear should be sufficient to ensure that the inner tank can, if required, develop an inelastic response.

**R8.3.6** Because pullout and punching shear are brittle failure in nature, no credit for ductility is permitted in the design.

**R8.4—Wall design**

## CODE

## COMMENTARY

**8.4.2** Construction access openings are permitted when design of the area within and adjacent to openings meets the performance requirements of 6.2 and 6.3. Design shall be based on analysis that includes time-dependent effects, prestressing and reinforcement details, and concreting procedure.

**8.4.3** Nonprestressed reinforcing shall comply with the requirements of Chapter 4.

**8.4.4** The prestressed concrete wall shall be analyzed for three basic load groups:

- a) Tensioning or prestress at transfer
- b) Normal loads alone
- c) Normal loads with all other applicable loads prescribed in Chapter 5

**8.4.5** The wall design shall comply with both the service and the strength requirements of the minimum performance requirements defined in Chapter 6 and as required in 8.4.6 through 8.4.17.

**8.4.6** The wall shall be provided with horizontal prestress.

**8.4.7** Loss of prestress due to friction loss, elastic shortening, and anchorage seating loss shall be calculated in accordance with ACI 350. Calculations for long-term prestress losses due to creep, shrinkage, and steel relaxation shall consider the specific material properties, service environment, steel percentage, and liner presence.

**8.4.8** All steady-state and transient temperature profiles and time-dependent material effects shall be considered for all loading combinations for the wall design.

**8.4.9** Vertical bending moments shall be included in the design of the wall. Prestressed and nonprestressed reinforcement shall be proportioned to resist the flexural tensile stress from bending loading conditions in combination with normal operating loads. Calculation of vertical bending moments that include severe thermal gradients shall include the nonlinear behavior of the concrete as a result of cracking.

**R8.4.6** Consideration should be given to space within the selected anchorage so that additional strands could be installed to compensate for the loss of prestressing force should a duct become blocked.

**R8.4.7** Long-term losses may be calculated in accordance with ACI 209R.

**R8.4.8** Section 8.1.1 requires analysis for the entire transient time history when considering the severe thermal loading conditions in 5.1.15 and 5.1.16.

In areas of the wall without discontinuities or embedments, the design of the wall cross section for the minimum compressive zone will typically be governed by the steady-state rather than transient thermal loading.

In areas with discontinuities or embedments, the self-straining forces will frequently be greatest at a transient temperature before the steady-state condition occurs. In a secondary containment, examples include the larger temperature differences between the wall and connected components such as a metal thermal corner protection (TCP) embedment or a base slab monolithic with the wall.

**R8.4.9** Vertical bending moments may be a result of the following factors:

- a) Internal and external loads in combination with base and top-of-wall restraints that exist during the combination of various loadings
- b) Non-uniform distribution of circumferential prestressing
- c) Temperature differences and gradients due to normal operation

**CODE**

**8.4.10** The average vertical prestress in the area of the buttress shall be adjusted to be approximately equal to the level of prestress in the wall.

**8.4.11** The anchorage zone shall be designed in accordance with ACI 350, Chapter 18, to resist the very high local stress due to the post-tensioning anchor.

**8.4.12** As a result of the impact load defined in 5.1.14, the wall thickness shall be 20 percent greater than the perforation thickness.

**COMMENTARY**

- d) Transient and steady-state thermal gradients due to spill and fire loading conditions
- e) Banding of prestressing resulting from reduced tendon spacing above and below the wall penetrations below the corner protection
- f) Attached structures
- g) Differential settlements
- h) Seismic loads (OBE, SSE, SSE<sub>aft</sub>)

**R8.4.12** Perforation is the passing of a missile completely through the impacted structural member with or without exit velocity. A perforation thickness is the thickness corresponding to a specific penetration resistance. Penetration is the displacement of a missile into an impacted structural member. It is a measure of the depth of the crater formed at the zone of impact.

If a structural member must act as a missile barrier, then it is necessary that the member be sufficiently thick so as to prevent perforation. The 20 percent increase in thickness is to account for uncertainty and is not considered an additional factor of safety (refer to ACI 349, Eq. (C.7)).

The following empirical equation may be used to evaluate the penetration resistance of concrete to a hard projectile.

$$v^2 = C f_c' w^{\frac{1}{3}} \left\{ D_p \frac{h^2}{m_p} \right\}^{\frac{4}{3}}$$

where  $C = 4640$ , and  $D_p$  is the projectile diameter.

This empirical equation for evaluating the penetration resistance of concrete to a hard projectile is described in the literature (Barbe and Costaz 1991; Kennedy 1976; Williams 1994). The formula is applicable to reinforced and prestressed concrete. Another useful source describing empirical formulas for concrete penetration, perforation, and scabbing is Bangash (2008). Additional information on projectile/missile impact can be found in the literature (Department of Defense 1990; Rotz 1976a,b; Jankov et. al 1976; Stephenson 1976; Barber 1973; Vassallo 1975; BS 8110-2).

Scabbing (the ejection of material from the back face of the impacted structural member opposite to the face of impact) and spalling (the ejection of material from the front face of the impacted structural member—that is, the face on which the missile impacts) may also occur, but are generally not a consideration unless the pieces of scabbed or spalled concrete can impact critical piping or equipment.

## CODE

**8.4.13** For walls with a thickness smaller than twice the perforation thickness, the minimum percentage of reinforcement shall be 0.2 percent in each principle direction and on each member face.

**8.4.14** The outer wall shall be designed to be liquid tight above the corner protection liner in accordance with 6.3.2 and 6.3.3.

**8.4.15** Pressure loads applied to the wall along the TCP shall be included in the design of the wall for both the maximum spill depth and for any intermediate spill depths.

**8.4.16** Embedment loads due to pressure and temperature effects shall be included in the wall design.

**8.4.17** When required by Chapter 5, the wall shall be designed for heat flux loadings to the surface of the wall, roof, or both. The reduced strength and nonlinear behavior of the material at elevated temperature shall be included in the evaluation of the strength of any cross section.

## 8.5—Roof design

**8.5.1** The roof shall be constructed of concrete with a minimum  $f'_c$  of 4000 psi.

**8.5.2** The minimum thickness of the dome roof shall be that required to provide:

- (a) Adequate buckling resistance for applied dead, live, and construction loads. If the roof is poured in layers, the loading due to the placed concrete shall be defined as a live load when considering buckling resistance
- (b) Adequate perforation thickness due to projectile impact
- (c) Sufficient thickness to provide thermal resistance to incident heat flux due to fire load combinations

## COMMENTARY

**R8.4.13** The minimum percentage of reinforcement requirement of 0.2 percent is as per ACI 349, F7.2.4. It should be noted that this minimum percentage is applied at each member face. The requirement is more conservative than that of ACI 349, Section 6.3.2.1 for slabs, and Section 6.5.5 for roofs. If the member thickness is greater than twice the perforation thickness, the minimum requirement does not apply.

**R8.4.14** The corner protection liner and bottom, if provided, form the liquid boundary for the lower portion of the wall and foundation.

**R8.4.15** The pressure may be reduced by the portion of the load resisted by the TCP liner if applicable.

**R8.4.17** Radiant heat flux may result from one of the following fire load cases:

- a) In-tank fire
- b) Adjacent tank fire
- c) Impoundment fire
- d) Process area fire
- e) Relief vent pipe fire

The heat flux values to be used in the evaluation shall include the wind speed producing the maximum incident flux, except for wind speeds that occur less than 5 percent of time for the given site. Strength reduction curves versus increased temperature are contained in BS 8110-2 for concrete, reinforcing, and prestressing steel.

## R8.5—Roof design

**R8.5.2** A method for determining the minimum thickness of a monolithic concrete spherical dome shell to provide adequate buckling resistance is given in ACI 350. This method is based on elastic theory of dome shell stability with the consideration of the effects of creep, imperfections, and experience with existing tank dome roofs having large radius-to-thickness ratios. The recommended minimum thickness to resist buckling is

$$h_d = r_d \sqrt{\frac{1.5P_u}{\phi\beta_{imp}\beta_c E_c}}$$

where  $P_u$  is obtained using the minimum load factors defined in ACI 350 for dead and live load;  $\phi = 0.7$ ; and  $\beta_{imp} = (r_d/r_{imp})^2$ .

In the absence of other criteria,  $r_{imp}$  may be taken as  $1.4r_d$ , and in this case,  $\beta_{imp} = 0.5$ .

## CODE

## COMMENTARY

$\beta_c = 0.44 + 0.003L$  for live loads between 12 and 30 lb/ft<sup>2</sup>,

$\beta_c = 0.53$  for live loads of 30 lb/ft<sup>2</sup> or greater,

$$E_c = 57,000\sqrt{f'_c}.$$

**8.5.3** The roof design shall include a roof liner as an integral part of the strength of the roof. The strength contribution of the liner shall include a reduction to include the weld efficiency.

**8.5.4** As a composite member, full transfer of horizontal shear shall be provided using properly anchored ties or headed studs. The maximum spacing of the ties or studs shall not exceed four times the roof thickness or 24 in.

**8.5.5** The minimum ratio of reinforcing area to concrete area shall be 0.0025 in both the circumferential and radial directions.

**8.5.6** Horizontal prestress shall be provided at the top of the dome or in the dome ring to eliminate the circumferential tension in this region resulting from the outward thrust of the roof due to the dead and live loads. The minimum residual compression stress at this location shall be equal to the minimum residual stress required in the remainder of the wall.

## CODE

## COMMENTARY

## CHAPTER 9—DETAILING

**9.1—General**

Details shall be designed in a manner that conforms to the structural, liquid tightness, moisture, and vapor permeation-control requirements, and performance criteria of this code.

**9.2—Reinforcement details**

**9.2.1 General**—Unless otherwise specified in this code, reinforcement details shall comply with the provisions of ACI 350, Chapter 7.

**9.2.2 Minimum nonprestressed reinforcement**

**9.2.2.1** Minimum reinforcement ratio of nonprestressed reinforcement used for control of cracking due to shrinkage and ambient temperature stresses shall comply with Table 9.2.2.1. Gross concrete area for calculating minimum reinforcement shall be based on the smaller of actual member thickness or 24 in. Reinforcement shall comply with 4.7 when minimum nonprestressed reinforcement is considered effective at service temperatures below 0°F.

**9.2.2.2** Where nonprestressed reinforcement is provided, spacing, distribution, and sizes of reinforcement shall comply with ACI 350, Chapter 7.

**R9.1—General**

Examples of overall tank configurations and details are provided in Appendix A. These represent configurations and details that have been used by different tank manufacturers in the past. They are not mandatory and are provided only for information and general guidance. The designer may use any variations of these sample details, or may design different details, provided they conform to the requirements of this code.

**R9.2—Reinforcement details**

**R9.2.1** In addition to meeting the requirements of ACI 350, Chapter 7, the selection of minimum concrete cover over the reinforcement should take into account the exposure classification, soil conditions, and emergency design conditions (for example, fire protection).

**R9.2.2.1** For additional guidelines regarding shrinkage and temperature reinforcement, refer to the provisions of ACI 350 and ACI 350.2R, Chapter 7. The amounts of shrinkage and temperature reinforcement specified in ACI 350 for deformed bars and welded wire fabric are empirical, but have been used satisfactorily for many years. Splices and end anchorages of shrinkage and temperature reinforcement should be designed for the full specified yield strength in accordance with ACI 350.

The minimum reinforcement ratios shown in Table 9.2.2.1 were compiled from the applicable provisions of ACI 350, 318, 372R, and 373R. A metal vapor barrier, if firmly fixed to the concrete by studs or other suitable means, may be considered as reinforcement for temperature and shrinkage as well as structurally composite reinforcement.

**R9.2.2.2** The required amount of shrinkage and temperature reinforcement is a function of the distance between the movement joints, concrete mixtures and other properties, amount of aggregate, member thickness, existing reinforcement, and environmental conditions. These factors have been considered in applying the analysis method developed by Vetter (1933) and Klein et al. (1981) to environmental engineering concrete structures, and the recommendations contained in ACI 350 are based on that work.

To control shrinkage cracks caused by restraint of free shrinkage, the reinforcement should be increased to 1.0 percent for approximately the first 4 ft when floor or wall concrete is placed against and bonded to previously placed concrete, such as at construction joints (for construction joint provisions and details, refer to 9.5.2 and Fig. R9.2.2.2). For crack control, the use of several small-diameter bars rather than an equal area of large-diameter bars results in a smaller calculated crack width.

## CODE

## COMMENTARY

**Table 9.2.2.1—Minimum temperature and shrinkage reinforcement in concrete RLG storage tank components**

			Tendon type <sup>a</sup>	Foundation slab <sup>†</sup>		Precast wall <sup>‡</sup>		Cast-in-place wall <sup>§</sup>		Roof
				Membrane	Structural	Sliding	Fixed	Sliding	Fixed	
Liquid containment (primary container)	Impervious Liner <sup>  </sup>	Prestressed	H	0.0015	0.0015	0.00	0.00	0.0025	0.0025	NA
			V	NA	NA	0.00	0.00	0.0025	0.0025	NA
		Nonprestressed	H	0.0025	0.0025	NA	NA	NA	NA	NA
			V	NA	NA	NA	NA	NA	NA	NA
	No liner	Prestressed	H	0.0025	0.0025	0.00	0.00	0.005	0.005	NA
			V	NA	NA	0.005	0.005	0.005	0.005	NA
		Nonprestressed	H	0.006	0.006	NA	NA	NA	NA	NA
			V	NA	NA	NA	NA	NA	NA	NA
Vapor containment (secondary container)	Impervious liner <sup>  </sup>	Prestressed	H	0.0015	0.0015	0.00	0.00	0.005	0.005	0.0025
			V	NA	NA	0.00	0.00	0.0025	0.0025	0.0025
		Nonprestressed	H	0.0025	0.0025	0.00	0.00	0.005	0.005	0.0025
			V	NA	NA	0.025	0.005	0.025	0.005	0.0025
	No liner	Prestressed	H	0.0015	0.0015	0.00	0.00	0.005	0.005	0.0025
			V	NA	NA	0.005	0.005	0.005	0.005	0.0025
		Nonprestressed	H	0.006	0.006	NA	NA	NA	NA	0.0025
			V	NA	NA	NA	NA	NA	NA	0.0025

<sup>a</sup>H = horizontal, and V = vertical.

<sup>†</sup>Each way.

<sup>‡</sup>Prestressed walls (both precast and cast in place) are prestressed both horizontally and vertically (precast walls vertically by pretensioning).

<sup>§</sup>Gross concrete area for calculating minimum reinforcement shall be based on the smaller of actual member thickness or 24 in.

<sup>||</sup>In the case of the foundation slab, the liner is on the top surface. Hence, the concrete is not in contact with the vapor.

### 9.3—Internal prestressing systems

**9.3.1 Tendon types, cover, and spacing**—Only grouted or bonded tendons are permitted for prestressing primary or secondary containers. Cover and spacing of grouted or bonded prestressing tendons and components shall be based on the following:

- Cover requirements shall comply with ACI 350
- Compatibility with methods used to properly consolidate concrete during placement
- Spacing between tendon ducts shall comply with ACI 350
- Tendon location shall comply with the performance criteria of Chapter 6.

#### 9.3.2 Tendon anchorage

**9.3.2.1** Design of buttresses or other concrete buildups used for tendon anchorage shall include the following:

- Forces from analysis in accordance with 8.1.1.1
- Unbalanced loading due to stressing sequence or changes in tendon force distribution
- Design of tendon anchorage zones in accordance with ACI 350, Chapter 18

### R9.3—Internal prestressing systems

**R9.3.1** Only grouted tendons are considered suitable for use in refrigerated liquefied gas (RLG) containments. After grouting, the prestress force is maintained in the event of tendon anchor failure.

For internal prestressing systems using buttresses and grouted tendons, emergency conditions (for example, fire scenarios) may influence the position of the various components (tendons and anchorages) of the prestressing system.

In very aggressive environments, where additional protection is required for the tendons, nonferrous prestressing ducts may be considered (The Concrete Society 2002; AWWA D110).

Adequate strength against radial tension leading to splitting/bursting of concrete and tendon pullout should be verified in regions where internal circumferential tendon ducts are closely spaced or tendon radius is small. Radial reinforcement ties should be provided where concrete splitting may occur.

**R9.3.2.1** Section 8.1.1.1 requires analysis for the effect of structural discontinuities, including those associated with buttresses or other concrete buildups for tendon anchorage. The greatest force in a tendon occurs during the stressing operation, and this combined with the sequence of jacking tendons will often result in the largest design forces. Consideration should also be given to changes in permanent tendon forces causing non-uniform loading of the buttress or buildup

## CODE

## COMMENTARY

**9.3.2.2** Unless otherwise specified, tendon anchors and end fittings shall develop the following strength requirements when tested in an unbonded condition:

- a) 100 percent of the specified breaking strength of the tendon when tested at ambient temperature
- b) 100 percent of the specified cold yield strength of the tendon when tested at the service temperature expected during normal operating and emergency conditions at the anchor location

due to unforeseen causes after construction begins, such as damage to a tendon or non-uniform friction.

Anchorage reinforcement detailing prescribed by the post-tensioning system supplier/manufacturer should be provided at all anchorages. The quantity of reinforcement in anchorage zones can be quite dense. Mockups should be considered for planning and training of personnel where the reinforcement layout is complex.

**R9.3.2.2** The number and details of testing should be part of the project specification.

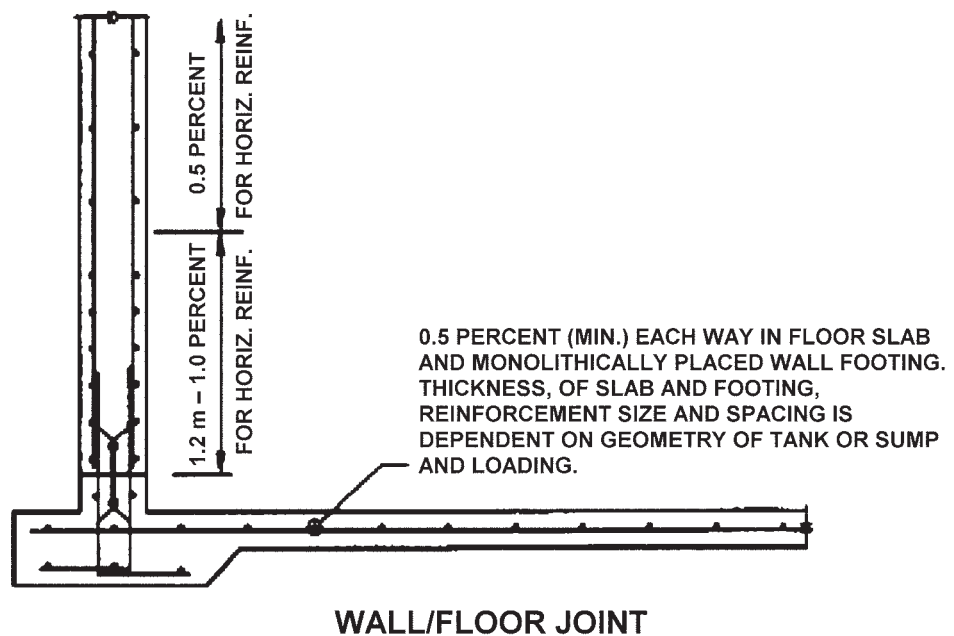
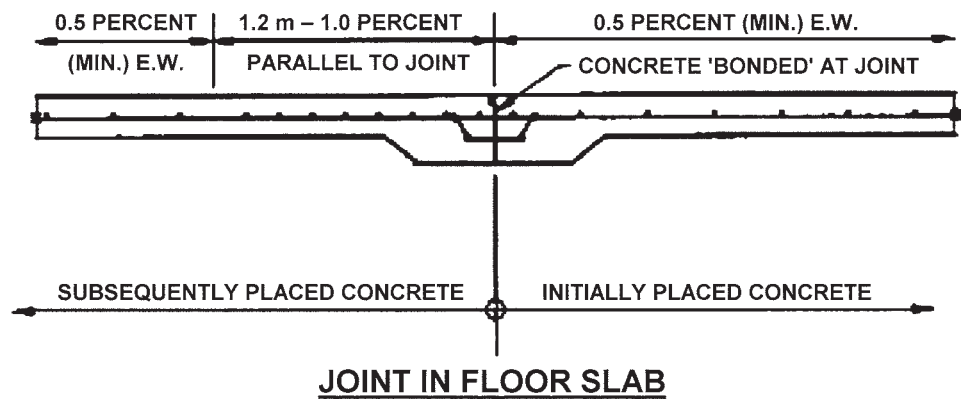

Fig. R9.2.2.2—Recommendations for increased reinforcing percentage parallel to bonded joints.



**CODE**

**COMMENTARY**

**9.3.2.3** Anchorages and end fittings shall be permanently protected against corrosion.

**9.3.3** *Tendon friction and anchor seating verification*—A minimum of one friction test and one anchor seating test shall be performed for each tendon size unless more are required by project specifications. Tendon stressing shall not be performed until the test results are reviewed by the responsible design professional and the tendon stress losses are found to be within acceptable limits.

**9.4—External prestressing systems**

**9.4.1** *Wire or strand spacing and shotcrete coating*

**9.4.1.1** Where prestressing is applied by means of wire or strand wrapping, the wire or strand shall be placed on the outer face of the wall in an essentially continuous helix with a clear space between wires or strands of not less than 5/16 in. or 1.5 times the wire or strand diameter, whichever is greater.

**9.4.1.2** Each layer of wire or strand shall be coated with shotcrete to provide a clear cover over the wire or strand of at least 1/4 in., but no less than the diameter of the wire or strand. After all the wires or strands have been placed and coated, a final coating of shotcrete shall be applied to provide a minimum thickness of 1 in. over the last layer wire or strand.

**9.4.2** *Outer shotcrete cover*—The outer shotcrete, repair mortars, and all exposed cementitious materials shall have a chloride ion permeability rating of low or lower (that is, very low or negligible) as per ASTM C1202.

**9.5—Concrete containment wall**

**9.5.1** *Minimum thickness*—The minimum wall thickness shall be determined such that:

- a) Cover and spacing requirements for reinforcement and internal tendons in 9.3.1 are met
- b) Stresses due to initial prestressing and subsequent loads are within the specified limits as defined in Chapter 6

**9.5.2** *Construction joints*

**9.5.2.1** Construction joints shall be detailed and located to ensure conformance with the performance criteria of Chapter 6. Required strength to resist design forces determined by analysis in accordance with Chapter 8 shall be provided by means of shear keys, roughened concrete surfaces, dowels, reinforcement, or prestressing steel.

**R9.3.3** The number and details of testing should be part of the project specification. Friction tests should be conducted by measuring jacking force and elongation on the stressing end of the tendon, and by using a load cell on the dead end.

**R9.4—External prestressing systems**

This section applies only to horizontal (circumferential) prestressing. Guidelines regarding wire- and strand-wrapping systems are contained in ACI 350, Appendix G, and ACI 372R.

**R9.4.1.2** The requirement for a minimum 1 in. cover over the last wire or strand is in accordance with ACI 350, G.4.2.4, as well as the other principal standards governing the design and construction of wire- and strand-wrapped tanks (ACI 372R and AWWA D110). For added durability, however, cover greater than 1 in. may be considered.

**R9.5—Concrete containment wall**

**R9.5.1** Cover and clear spacing limitations for walls constructed with internal tendons that have reinforcement on both faces and are consolidated with internal vibrators will typically result in minimum thickness of approximately 12 in. plus the duct diameter.

**R9.5.2.1** Form height selected for a project will generally dictate the location of horizontal construction joints for cast-in-place concrete containment walls.

Special attention should be paid to detailing and location of the construction joints, especially in areas where liquid tightness is required. For the areas where liquid tightness of concrete is to be assured, details and methods of construction should be based on proven practices or testing. The engineer

**CODE****COMMENTARY**

**9.5.2.2** Written procedures describing surface preparation, materials, and methods for the construction-joint construction shall be prepared and approved by the engineer.

**9.5.3** *Wall-to-base connection details*

**9.5.3.1** Primary and secondary wall-to-base connections shall be detailed to meet structural, liquid tightness, moisture, and vapor permeation-control requirements, and performance criteria of this code.

**9.5.3.2** Monolithic or fixed wall-to-base connections shall have sufficient strength to resist design forces determined by analysis in Chapter 8.

**9.5.3.3** Values of friction or resistance to sliding used in the structural analysis shall be verified by field testing or laboratory testing of components for the following wall-to-base details:

- a) Monolithic connections using a temporary construction gap in the foundation during application of horizontal prestressing
- b) Connections using temporary sliding joint during application of horizontal prestressing that is subsequently fixed
- c) Connections using permanent sliding joint during application of horizontal prestressing and subsequent service life

**9.5.3.4** Unlined wall-to-base connections with a permanent sliding joint shall be protected with a durable permanent cover.

**9.5.3.5** Those portions of concrete containment wall and base protected by insulation from product contact shall meet at least one of the following requirements:

- a) Use of insulation that maintains its insulating and structural properties when exposed to product liquid or vapor

should provide details and parameters for joints, and coordinate the joint design with the contractor's execution plan. Field quality control plays an important role in validating the construction at joints where liquid tightness is a concern.

**R9.5.3** Refer to Appendix A for discussion of the types of wall-to-base connections typically used for RLG containments. Full-containment tanks that have been built typically use a monolithic wall-to-base connection for cast-in-place construction of secondary containers. Thermal corner protection (TCP) is typically provided for an RLG product over the base and a portion of the containment wall. Warmer products, such as propane or butane, have been built with load-bearing insulation suitable for permanent contact with product liquid or vapor.

Full-containment tanks of prestressed concrete construction that have been built have used a sliding joint for both primary and secondary containers. Bund walls that provide secondary containment only are typically built with pinned or sliding joints at the base of the wall. Temporary or permanent sliding base joints facilitate hoop prestressing.

**CODE**

**COMMENTARY**

b) Use of a metallic cover that prevents direct contact of insulation with product liquid or vapor and resists the pressure of product liquid or vapor. Metallic covers shall be continuous over the product height or anchored to the concrete wall in a manner that prevents product from leaking behind the metallic cover.

**9.5.4 Wall penetrations**

**9.5.4.1 Double- and full-containment tanks**—No permanent penetrations of the primary or the secondary wall, floor, or both, shall be allowed for double-containment tanks, full-containment tanks, or both.

**9.5.4.2 Single-containment tanks and bund walls**—Where penetrations are provided in single-containment concrete tanks, detailed analysis, design, detailing, and testing shall be performed to demonstrate structural integrity and continuity of prestressing and reinforcement. Liquid tightness of penetrations shall be based on proven practices or testing.

**9.5.4.3 Temporary openings**—Temporary openings in the unlined primary tanks used in double tank systems, full-containment tank systems, or both, are not permitted unless detailed analysis, design, detailing, and testing are performed to ensure liquid tightness.

**9.6—Metal components**

**9.6.1 General**—Unless otherwise specified or permitted in this code, details of metal components, including weldment details, shall be in accordance with the provisions of API 620.

**9.6.2 Metal liners** shall pass the test requirements in 4.13 to maintain integrity, free from tears or cracks, during service conditions.

**R9.5.4.1** Current practice for full containment of refrigerated liquefied gas (RLG) is to have no permanent penetrations below the liquid level through the wall or foundation of primary and secondary containers.

**R9.5.4.2** Bund walls have been constructed with manholes and pipe penetrations through the containment wall. In such cases, particular attention needs to be paid to maintaining structural integrity and leak tightness at the penetration.

**R9.5.4.3** Where penetrations are used and liquid is in direct contact with concrete, the penetrations should have seepage collars or other positive means of preventing leakage of product liquid or vapor. Calculations may be used to evaluate expected behavior at penetrations. Because of the complex behavior at penetrations, testing for liquid tightness is recommended where potential minor leakage would represent a significant hazard.

Representative testing of the temporary opening under operation-temperature conditions should be performed. In all testing, the temperature effects should be included as an essential variable.

**R9.6—Metal components**

**R9.6.1** Metal components covered by this section include the floor and subfloor plates, annular base and skirt plates, wall metal liners, steel roof support systems, and roof plates. Details of metal components for anchoring to elements of the concrete containment are covered in 9.7.

**R9.6.2** A metal liner acts as an impervious barrier in direct contact with, and usually bonded to, the concrete. Liners may occur either as an outer wall lining or as an inner wall lining. The primary functions of a liner are:

- a) To make the containment structure gas-tight, liquid-tight, or both
- b) To prevent water vapor penetrating the containment, which could reduce insulation and form ice within the containment system

The design of the liner should consider:

- a) Service conditions
- b) Potential thermal shock
- c) Extra gas pressures
- d) The need to bridge cracks in the concrete
- e) Resistance to fire

## CODE

## COMMENTARY

**9.7—Anchorage to concrete**

**9.7.1 General**—This section is applicable to design and detailing of metal components for anchoring to elements of concrete containments.

**9.7.2** Unless otherwise specified or permitted in this code, details of metal components, including weldment details, shall be in accordance with the provisions of API 620.

**9.7.3** Unless otherwise specified, anchoring to concrete shall comply with ACI 350, Appendix D.

**9.7.4** The temperature used in design shall be based on location as follows:

- a) Product temperature where metal components are below the interior liquid level of primary or secondary containments.
- b) The temperature determined from analysis in accordance with Chapter 8 where metal components are above the interior liquid level of primary or secondary containments.
- c) The temperature determined from analysis in accordance with Chapter 8 for metal components on the exterior of concrete containments exposed to the atmosphere. Alternatively, the design metal temperature is assumed to be 15°F warmer than the lowest 1-day mean ambient temperature for the site.

**9.7.5 Details**—The following requirements shall be considered in design and detailing of metal components for anchoring to concrete.

- f) Resistance to blast and impact
- g) Resistance to earthquakes
- h) Residual weld stresses
- i) Concrete strain due to shrinkage and prestressing
- j) Liners, except for sacrificial liners, must be ductile at all design temperatures except for cases where the liner remains in compression for all load combinations due to the effects of prestressing

There is a distinction between a liner and a membrane. A membrane is an impervious barrier separated from the concrete by insulation. A liner is in direct contact with the concrete.

Liners are mostly fabricated from steel. Nonmetallic materials may be used, provided their performance as liner is demonstrated. Steel liners are typically fixed by welding to embedments anchored to the concrete structure by shear studs. Liners subject to significant strains from low temperatures may require cryogenic-grade material such as nickel steel unless precompression is ensured for all design cases.

**R9.7—Anchorage to concrete**

**R9.7.1** Metal components covered by this section are the structural anchorage for pipe supports, stairs, ladders, steel liners, embedments, and other items supported directly by concrete foundations, walls, or roofs of primary or secondary containments. Components directly in contact with product, product vapor, and the exterior environment are included.

Stainless steel or similar material suitable for product temperature is recommended for headed studs or other anchorage devices for all interior locations whether below or above the product liquid surface.

**R9.7.5** Metal pad plates with square corners that are cast flush with the concrete surface are subject to cracking due to

**CODE**

- a) Provide rounded corners or other details that minimize shrinkage cracking of concrete at the corners where metal pad plates are cast directly into concrete.
- b) For exterior locations exposed to the atmosphere, use corrosion-resistant materials or provide coatings to protect metal components. Seal the edges between metal components and concrete to prevent ingress of moisture unless corrosion-resistant materials are provided.
- c) Weld shrinkage associated with welding of attachments when such shrinkage can cause cracking in the adjoining concrete.

**9.8—Liners and coatings**

**9.8.1 General**

**9.8.2 Secondary (outer) container**—Liners or coatings shall be applied on the secondary container to meet moisture and vapor penetration resistance requirements specified in Chapter 6.

**9.8.3 Primary (inner) container**—Liners, coatings, or both, shall be permitted to be used on primary (inner) concrete containers.

**9.8.4 Concrete roof**—An internal liner or coating shall be used to ensure the vapor tightness of the concrete roof.

**9.8.5 Metal liners**—Metal liners equal to or thicker than 0.12 in. shall conform to the requirements of 4.13. Metal liners less than 0.12 in. thickness shall be designed to conform to the applicable performance criteria of 4.15.

**9.8.6 Internal coatings**

**COMMENTARY**

concrete shrinkage. Rounded corners or a small gap around the edges of the pad plate will minimize cracking.

Moisture entering along the edges of an embedment can cause long-term corrosion unless corrosion-resistant materials are used. A small gap around the edges as described in 9.7.5(b) provides a means of sealing the edges.

Weld shrinkage associated with welding to metal embedments causes distortion of metal components relative to concrete surfaces. To minimize the effect, the smallest practical weld size and heat input should be used.

Continuous circumferential embedments, such as those used for anchorage of TCP, will shrink away from the concrete surface, and without careful design and detailing should not be relied on as an effective liquid barrier between the concrete containment and the metal corner protection.

**R9.8—Liners and coatings**

**R9.8.1** Liners or coatings may be used as vapor barriers or vapor/liquid barriers for the secondary (outer) and/or primary (inner) walls, roof, and subfloor. The following materials may be used:

- a) Steel plates as liners
- b) Reinforced or unreinforced polymeric layers as coatings

**R9.8.4** In the case of a metal liner for the concrete roof, the liner may serve as formwork for the concrete and may also act compositely with the use of shear studs. The concrete may be built up in layers to prevent overstress of the liner.

**R9.8.5** Metal liners should be considered vapor- and liquid-tight as long as the material selection is appropriate. The material selection should be based on the design metal temperature to be determined by the contractor in conjunction with the specified allowable stress limits. The minimum thickness of a metal liner should be selected based on its ability to meet the project design requirements and availability and constructability, including welding, but should not be less than 0.12 in. Performance of metal liners less than 0.12 in. thick may be approximated by that of coatings. Any creep or long-term deformation of the concrete due to operational conditions applied to the structure should be taken into account for the design of the liner. The anchoring system should be designed for combined shear and tension.

**R9.8.6** Internal coatings can be used as barriers to product vapor and liquid product penetration into the concrete. A primary function is the need to bridge cracks in the concrete.

## CODE

## COMMENTARY

**9.8.6.1** Internal coatings shall conform to the requirements of 4.15.

**9.8.6.2** Internal coatings shall be applied directly to the concrete surface. Before application, the concrete surfaces shall be grit-blasted or otherwise treated to make them compatible with the coating system.

**9.8.6.3** Internal coatings shall be tested to verify that they are acceptable for the intended service.

**R9.8.6.3** The scale of testing should be selected so that the testing is representative of the conditions experienced during long-term use. These include, but are not limited to, the effect of concrete creep and shrinkage, as well as load and temperature-induced deformations.

**CODE**

**COMMENTARY**

**CHAPTER 10—FOUNDATIONS**

**10.1—General**

**10.1.1** RLG containers shall be supported on foundations designed by the foundation engineer in accordance with recognized and generally accepted structural engineering practices.

**10.1.2** The tank foundation shall be designed so as to transmit all loadings to suitable load-bearing strata and meet criteria for settlement, sliding resistance, bearing, overturning resistance, and soil liquefaction as defined in accordance with design criteria from a geotechnical investigation complying with 10.2.

**10.1.3** The foundation shall be designed to support the RLG tank within the parameters in this document.

**10.1.4** Structural design of foundations shall be in accordance with ACI 350.

**10.2—Geotechnical investigation**

**10.2.1** *Investigation and engineering analysis*—A foundation investigation and engineering analysis shall be specified and supervised by a geotechnical engineer experienced in the design of the foundations being considered for the site. The investigation shall determine the stratigraphy and physical properties of the soils underlying the site. Section 10.2.2 specifies the minimum extent of soil investigation. Further guidance on investigation and testing shall be specified by the geotechnical engineer.

**R10.1—General**

Foundations can be deep or shallow and the construction process may include soil improvement. Various foundation configurations for support of refrigerated liquefied gas (RLG) tanks are illustrated in Appendix A. Shallow foundations are used where subsurface materials are suitable for direct support of the tank and its contents within settlement limits that are compatible with the tank performance requirements. They typically consist of an annular ring foundation for support of the tank shells and an interior concrete slab for full and secondary containment systems. Deep foundations are used where the structure loads have to be transferred to underlying competent soil or rock. Deep foundations typically consist of a structural slab or a beam and slab system supported by driven or drilled piles. Various soil modification techniques may be used to improve the physical properties of soils to use more cost-effective foundation types or to prevent liquefaction during earthquakes.

**R10.1.3** Local regulations or statutes may impose more severe requirements.

**R10.2—Geotechnical investigation**

**R10.2.1** Foundations are critical to the performance of refrigerated liquid gas tanks and the limitations on settlement are very strict, as defined in this code. Foundations require detailed geotechnical information-gathering, design, and performance testing during construction.

Compressibility, shear strength, and drainage characteristics of the soils and the location of the groundwater table are some of the fundamental information needed for foundation design. Other physical properties that may be required include:

- a) Shear modulus of the soil
- b) Soil thermal and electrical conductivity

Chemical properties of the soil should be determined especially for evaluation of the potential for the soil to cause corrosion and sulfate attack, and detection of solubility.

## CODE

**10.2.1.1** The structural engineer shall provide the following information to the geotechnical engineer:

- a) Tank and foundation configuration
- b) Gravity loads and wind and seismic forces acting on foundations
- c) Presence of tension uplift forces
- d) Permissible settlement limits if more restrictive than this code

**10.2.1.2** Where deep foundations are to be used, the geotechnical engineer and structural engineer shall agree on the types and sizes of piles to be examined during the investigation.

**10.2.2** *Number, location, and depth of boreholes and cone penetration tests*

**10.2.2.1** Unless otherwise specified in the project documents, where foundations are not supported directly on rock, the following minimum number of boreholes or CPTs shall be performed:

- a) For all tanks, one borehole at the tank center and three boreholes or CPT soundings equally spaced at the tank perimeter
- b) For tanks larger than 100 ft in diameter, perform one additional borehole or CPT inside the tank footprint for each additional 10,000 ft<sup>2</sup> of tank area.

**10.2.2.2** Additional boreholes or CPTs shall be performed if the site topography or stratigraphy is uneven, if fill areas are anticipated or encountered by the geotechnical investigation, or if the soil strata vary horizontally.

**10.2.2.3** Boreholes shall be taken to below the depth of significant foundation influence or to a competent stratum.

**10.2.2.4** The target and completion depths of boreholes shall be specified or approved by the geotechnical engineer.

**10.2.2.5** If boreholes encounter bedrock, then rock corings shall be taken to provide information on the rock's soundness and physical properties.

**10.2.2.6** The subsurface investigation shall be made to the depth and extent to which the tank foundation will increase the vertical stress no more than 10 percent of the effective overburden stress in the supporting soil or rock wherever compressibility of the entire stratum is a consideration.

## COMMENTARY

**R10.2.1.1** The size and weight of a tank will strongly influence the scope of the subsurface investigation. Depending on the predominant type of foundation material present at the site, the investigation may typically include gathering of existing data, cone penetration tests (CPTs), boreholes, trial pits, field load tests, sampling, laboratory testing, and geophysical surveys. A phased investigation process normally yields the optimum amount of information cost effectively.

**R10.2.1.2** Where the design requires the use of deep foundations, the geotechnical engineer should provide axial pile capacities for each size and type of pile recommended. Particularly in seismic regions, information for the prediction of lateral pile load-deflection behavior should be furnished.

**R10.2.2** Borings are generally small-diameter holes drilled into the ground to allow soil classification, determination of groundwater, access for in-place tests, standard penetration tests (SPT), and collection of soil samples for additional tests.

**R10.2.2.1** CPTs are recordings of physical soil properties made when a sensing probe is pushed into the ground. The basic probe has a cone-shaped tip with a pressure transducer recording the soil response to the pushing force. The side of the probe has a transducer that measures the side friction force against the probe. Other sensors may be mounted on a probe to measure pore water pressure, electrical conductivity, and shear wave velocities. Commonly, the boring/CPT locations are laid out in a grid around the center location with the objective of each location covering approximately the same area.

**R10.2.2.6** The following factors may influence the selected depth of borings:

- a) Depth at which consolidation of the soil under the tank load becomes negligible, whether the foundation is a slab-on-ground or pile-supported
- b) Depth of intact rock
- c) Depth needed to classify the site according to Chapter 20 of ASCE/SEI 7



**CODE**

**COMMENTARY**

Selected depths of boring may be influenced by the fact that at depths beyond the local influence of the tank walls, the increment of vertical stresses at any constant elevation below the tank foundation will be greater under the center of the tank than under the perimeter.

The stress distribution in the ground under a tank can be defined using a Boussinesq pressure distribution. As an example, consider a site with the water table at the ground surface and a submerged unit weight of soil of 65 lb/ft<sup>3</sup>. Assume that a tank of 250 ft diameter (*D*) causes a uniform ground pressure of 5000 lb/ft<sup>2</sup>. Under the center of the tank at a depth of approximately 0.95*D*, the construction of the tank causes an increase of vertical stress of 10 percent. Under the edge of the tank, the increase of vertical stress is 10 percent at a depth of approximately 0.85*D*.

The guidance provided by calculating stress increases will generally give acceptable results for tanks 200 ft and greater. For tanks of smaller diameters, the investigation should extend to a depth of 1.5 tank diameters when deposits of soft clay or loose sand are present.

Potential compression of soil strata beneath the pile tips should be considered in selecting depths of borings for tanks to be supported on piles in normally consolidated or slightly overconsolidated soils. Negative skin friction should be considered if soil conditions such as underconsolidated layers are encountered or if the tank site is to be filled with a soil embankment.

Whenever reliance will be placed on the strengths or compression indexes measured on cohesive samples, the samples should be taken by a pushed thin-wall sampler to reduce disturbance. Consideration may be given to performing x-ray or computer tomography (CT) scan examination to detect disturbance and identify inclusions, voids, or fractures that might affect test results.

**10.2.2.7** CPTs shall be pushed to refusal.

**R10.2.2.7** The CPT is an efficient tool for in-place characterization of wide areas when used in combination with boring and sampling. It is usually faster than standard borings, and the results are more repeatable than standard penetration tests or laboratory strength testing. The most modern and reliable methods of pile design for sands rely directly on CPT results. CPT results are also useful for evaluating the potential for soil liquefaction.

CPTs are preferred for the additional locations above the minimum number of borings required by the geotechnical engineer. It is normally cost effective to perform some CPTs first to develop the sampling plan for the borings.

The depth to which CPTs can be pushed can be extended by using push-rod stiffening casing pushed over the drive rods to protect the rods against bending in soft soils. This technique is useful in upper sediments. Consideration should be given to using a CPT with a piezometric recording feature (PCPT), as it provides more information on the strata. It is suggested that one CPT be performed within a few meters of the center borehole to provide improved correlation data. A seismic CPT cone can provide measurements of dynamic

**CODE****COMMENTARY****10.2.3 Earthquake geotechnics**

**10.2.3.1** A site-specific seismic hazard assessment shall be performed to determine the seismic ground accelerations, velocities, and displacements that would likely occur at the site. The information from the hazard assessment shall be used to calculate the seismic response of the structures.

**10.2.3.2** For ASCE/SEI 7 Site Classes C, D, and E, a soil-structure interaction analysis shall be performed for the final design of the tank and its foundation.

**10.2.3.3** A seismic analysis shall be performed in accordance with 8.1.3 and NFPA 59A.

**10.2.3.4** The geotechnical investigation shall specifically evaluate the potential for soil liquefaction and lateral spreading under the operating basis earthquake (OBE) and the safe shutdown earthquake (SSE), and the geotechnical report shall address measures to mitigate soil liquefaction and lateral spreading where the potential exists.

**10.3—Design requirements for shallow foundations**

**10.3.1 General**—Shallow foundations shall be designed in accordance with 10.3.2 through 10.3.5.

soil properties more cost effectively than other methods, if collecting such data is justified.

Twenty-five tons is a recommended minimum weight for a truck-mounted CPT rig used to gather data by semi-continuous pushing without intermittently cleaning out the hole. A heavy reaction for the CPT rig is necessary to achieve the depths of measurement required for pile design or predicting the behavior of a shallow foundation under a large tank. In marshy areas, it may not be possible to mobilize a rig weighing 25 tons; however, the measurements will still have value even though a lower reaction weight is used. Intermittent hole cleaning between short tests can be used to extend the depth of testing.

**R10.2.3.4** Driving of piles will densify loose soils, which should be taken into account in predicting whether or not liquefaction will occur. Various methods of soil improvement can be used to densify or cement loose soils to mitigate the effects of liquefaction.

Mitigating measures, tank design, and foundation design should work together to ensure that the performance criteria of NFPA 59A, Section 7.2.2.5, are satisfied.

**R10.3—Design requirements for shallow foundations**

**R10.3.1** A shallow foundation should be designed to distribute the weight and other loads on the tank to soils immediately below the tank. The strength of the underlying soils should be sufficient to further distribute the forces into the ground.

A shallow foundation could be a ring beam, a flat slab/mat, a slab/mat with varying thickness, a slab/mat surrounded by a ring beam, a grid system of grade beams, or a series of box structures. Transitional zones should be provided below the tank bottom to avoid abrupt changes in select fill or foundation thickness.

Rafts or shallow mat foundations can be designed as a system of cellular boxes, that is, a grid system to reduce weight and provide stiffness. If the cells are above grade, open, and oriented to prevailing winds, the cells can provide protection against frost heave without the use of electrical

**CODE**

**COMMENTARY**

**10.3.2 Allowable bearing pressure**

**10.3.2.1** Shallow foundations shall be designed so the allowable bearing pressure acting on the soil is not exceeded.

**10.3.2.2** Analyses shall account for the redistribution of bearing pressures that is caused by lateral loading on the tank.

**10.3.2.3** Ultimate bearing capacity  $q_u$  shall be determined by the application of geotechnical and civil engineering principles in conjunction with the geotechnical investigation.

**10.3.2.4** Allowable service load bearing pressure  $q_a$  shall be the smaller value determined from:

- a) Permissible total and differential settlement
- b) Ultimate bearing capacity divided by a safety factor from Table 10.3.2.4

**Table 10.3.2.4—Minimum factors of safety for shallow foundations in bearing**

Loading condition	Minimum factor of safety
Normal operation	3.00
Hydrostatic loading	2.40
Wind or OBE seismic	2.25
SSE seismic	1.50

**10.3.3 Overturning effects and anchorage**

heating systems. Consideration should be given to the sizes of openings required for inspection and measurement of settlements. Rafts or mats for small tanks can be designed with a larger diameter than the tank to reduce the loads on the soil.

Concrete ring beam foundations should be designed using the procedures found in PIP STE03020. Ring beam foundations are normally sized such that the bearing pressure below the ring foundation is approximately equal to the average sustained pressure below the tank at the same depth. Ring beam foundations should be adequately reinforced to resist hoop stresses. The magnitude of the lateral pressure is heavily dependent on the type of fill material used inside the ring and the method of placement.

**R10.3.2.1** The adequacy of the foundation should also be checked for both edge shear and base shear. The approach defined in Duncan and D’Orazio (1984) could be used for this purpose. Edge shear involves failure of the shallow soil layers under a part of the tank perimeter. Base shear involves failure of the deeper soil layers under the tank, allowing rotation as an entire unit.

**R10.3.2.3** Ultimate bearing capacity  $q_u$  is the limiting pressure that may be applied to the soil/rock surface by the foundation without causing a shear failure in the material below the foundation.

**R10.3.2.4** The safety factors of Table 10.3.2.4 are intended to be used with nominal (unfactored) loads and are intended to account for both the uncertainties in load and resistance in one factor. Load combinations defined in Table 5.2.2 should be used.

In rare instances, the minimum safety factors in Table 10.3.2.4 may be reduced, provided the geotechnical investigation and subsequent analysis have rigorously established that expected deformations and probabilities of failure are acceptable.

**R10.3.3** A calculation of overturning resistance has meaning where the footing can tilt as a rigid body and the tank could actually be forced by overloading to tip over without first collapsing. A tank or process vessel that is small enough to be lifted in one piece by a crane and transported on a truck or rail car is a likely case where the calculation of overturning resistance has meaning. Properly designed tanks subjected to lateral loads from earthquakes or winds beyond their capacity to resist will generally fail due to structural collapse before overturning as a rigid body. Even

## CODE

## COMMENTARY

**10.3.3.1** Calculations shall be performed to determine the effects of overturning moments on the tank both when full and empty, and resistance to the effects shall be provided.

**10.3.3.2** The combined effect of overturning moment and the tendency for gas pressure against the roof to lift the walls shall be considered in determining the need for uplift resistance.

**10.3.3.3** Shallow foundations shall be sized to resist uplift forces where needed.

**10.3.3.4** Anchorage details shall be capable of accommodating movement of the tank wall caused by thermal changes.

**10.3.4** *Sliding resistance*—The minimum factor of safety against sliding shall not be less than 1.5 for wind and OBE loading cases, and 1.2 for SSE loading cases.

a small, thick-walled tank on a shallow foundation loaded to the point of tipping will generally cause a bearing capacity failure in the soil in the course of tipping over. Ensuring that a bearing capacity failure does not occur under the design loads will also ensure that the tank does not tip over.

During the OBE and SSE events, overturning resistance is provided by the self-weight of the outer and inner tank. The excess of the roof's weight over the pressure of the gas supporting it, if any, will also resist uplift, but the gas pressure can also contribute to wall uplift if the gas pressure exceeds the weight of the roof. Non-uniform hydrodynamic base pressures should be considered in determining the moment-couple on the foundation. The weight of the foundation can be included in overturning resistance if the tank is adequately anchored to the foundation.

Overturning resistance will generally exceed overturning moments in the tanks treated by this code because of the tanks' weights, large diameters, and proportions. Excessive overturning moment will generally cause a bearing capacity failure of the soil, overstress in the foundation slab, or severe wall deformation first before overturning of the tank could occur. Where overturning is a possible failure mode, the factor of safety against overturning should be not less than shown in Tables 10.3.2.4 and 10.4.4.

**R10.3.3.2** Civil engineering structures normally have a structural element in direct contact with ground (for example, foundation, piles, and mats). When the external forces, such as earthquakes, act on these systems, neither the structural displacements nor the ground displacements are independent of each other.

Internal gas pressure in the tank does not have any effect on total vertical load, global overturning moment, or global overturning resistance, but it affects the distribution of foundation pressure as well as stress distribution in the tank walls and roof under all loading conditions. Therefore, the contribution of gas pressure to uplift of the wall should be considered in combination with any uplifting effect from overturning moment.

**R10.3.4** Sliding resistance may be provided by frictional forces due to self-weight of the combined tank system. Sliding resistance should be checked over a range of conditions, including tank empty and tank full.

For granular soil, sliding resistance is governed by the coefficient of friction between the soil and the foundation

## CODE

## COMMENTARY

**10.3.5 Settlement**—The effect of immediate and long-term settlement on strength and serviceability shall be considered in the design of foundation base slabs, containments and connections to adjacent equipment, plant piping, and other systems.

**10.3.5.1** The maximum settlements during the life of the tank shall be within the permissible settlement limits for the tank and associated tank components.

**10.3.5.2** Unless otherwise specified in the project documents, maximum limits for settlements of concrete shallow foundations shall be as follows:

- a) Uniform settlement shall be permitted, provided the other provisions of the section are met and the connecting piping system will accommodate the settlement.
- b) Differential settlement or uniform (planar) tilting (when the tank foundation tilts uniformly to one side) shall be limited to a maximum of 1/500.
- c) Dishing settlement measured along a radial line from the outer perimeter to the tank center shall be limited to a maximum of 1/300.

plus the roughness and shape of the foundation. For cohesive soil, sliding resistance is governed by the adhesion of the soil to the foundation and the shear strength of the soil plus the shape of the foundation.

The calculated resistance to sliding of a tank on a shallow foundation may be taken as a coefficient of friction times the weight of tank and contents including the reduction in normal force due to vertical earthquake. The maximum ultimate coefficient of friction should be  $\tan 30^\circ$  unless testing validates a higher value. The maximum allowable frictional resistance under wind lateral load is equal to 0.40 with a safety factor of 1.5. The coefficient of friction should consider the materials underlying the tank bottom. Alternatively, shear keys may be constructed within the foundation to mobilize passive pressure effects and increase the sliding capacity of the foundation.

**R10.3.5** The settlement requirements in this code serve as guidance and should be agreed upon with the tank supplier and the owner. Settlement calculations should assume that the tank is full for its design life when considering the effect of settlement in the design of primary- and secondary-containment tanks. The range of possible settlement needs to be considered when designing connections to adjacent equipment, plant piping, and other systems that connect to containments.

**R10.3.5.1** Requirements for limiting settlement will generally govern the foundation design of large refrigerated tanks with foam-glass insulation in the bottom slab. Predictions of settlement using the tank's weight, the compressibility of the soil, and assumed stress distributions in the soil may limit allowable bearing pressure to values lower than those calculated with the factors listed in Table 10.3.2.4. Such a limitation may be necessary for an overconsolidated clay simply because of the long-term static load of a full tank and the soil's consolidation. The effects of cyclic loading should be considered for a large shallow foundation on sand. Settlements can accumulate in loose or medium-dense sand with the repeated emptying and filling of the tank even though the pressures during service are well below the ultimate bearing pressure.

**R10.3.5.2** Restricting the dishing settlements to 1/300 maintains the bending curvatures within acceptable limits so that insulation materials (foam-glass) are not damaged.

**CODE**

d) Foundation settlement around the perimeter of the tank shall be limited to the lesser of: 1) 1/500; and 2) the maximum settlement limit calculated for the uniform tilting of the tank.

**10.3.5.3** Computation of settlements shall take into consideration the effects of adjacent tanks, tank foundation/wall stiffness, fill surcharge, soil stiffness, time required for consolidation, soil variability, and the reliability of the site investigation.

**10.4—Design requirements for deep foundations****10.4.1** *General requirements*

**10.4.1.1** The selection and design of the deep foundation system shall be conducted by the foundation designer in close cooperation with the geotechnical engineer and the structural engineer.

**10.4.1.2** The selection and design of the deep foundation system shall be based on a geotechnical investigation of the in-place foundation conditions, and shall take into account the engineering properties of those foundations.

**10.4.2** *Piles***COMMENTARY**

**R10.3.5.3** Fill surcharge is the weight of fill material over the original grade. It does not include preload surcharge for ground modification.

**R10.4—Design requirements for deep foundations**

**R10.4.1.1** The structural engineer should use the geotechnical information combined with engineering properties of the deep foundation systems to design and specify the deep foundation system. The structural engineer, in cooperation with the geotechnical engineer, should specify such performance testing and testing frequency to ensure that the constructed foundation is adequate to perform the functions required.

Considerations in the design of the deep foundation system besides the soil engineering properties should include material availability, potential contractor capability, constructibility, equipment availability, and local requirements. The performance-testing program should be designed by the structural engineer and the geotechnical engineer to establish the most cost-effective pile design.

**R10.4.1.2** Because deep foundations are typically constructed of numerous individual components whose capacities are additive to provide the strength of the foundation, great care in geotechnical information gathering, design, construction, and performance testing of all components or representative samples is required.

**R10.4.2** Piles can include both driven piles and cast-in-place concrete piles. An early pile selection and testing program to test and determine pile load characteristics, pile installation methods, and procedures can be beneficial. Such a program is most effectively conducted shortly after the geotechnical investigation. Where possible, all piles installed under the program should be electronically monitored and evaluated. Tested piles may be incorporated into the final design. The program, however, does not represent the start of construction as it is an extension of testing.

A static analysis should be performed using an acceptable and proven method for the area where the piles are being driven. Effects such as additional fill, water table level, pile group efficiency, corrosion protection, and pile splicing should be taken into consideration when the pile type and length are chosen.

**CODE**

**COMMENTARY**

**10.4.2.1** *Driven piles*—Dimensional tolerances for the production of precast concrete piles, both solid and hollow, shall be in accordance with PCI MNL-116-99.

**R10.4.2.1** Driven piles can include open or closed steel pipe piles, H-piles, single or spliced solid prestressed concrete piles, and concrete cylinder piles. Concrete piles with cast-in-place splicing devices may reduce transportation and handling requirements significantly enough to justify the general use of splices for long piles.

Pile blow counts for driven piles should be recorded electronically. A pile inspector, qualified as per project specifications, should be present during fabrication and driving of all piles. Examples of adequate qualifications can include completion of a U.S. Federal Highway Administration’s (FHWA’s) pile inspector course together with experience in inspecting piles acquired by working under previously qualified pile inspectors.

**10.4.2.2** *Cast-in-place piles*

**R10.4.2.2** Cast-in-place piles include drilled caissons, drilled piers, auger-cast-in-place piles, and auger-displacement-pressure-grouted piles (ADPGP). Proprietary methods of construction are often used.

Cast-in-place pile safety factors are usually higher than those for driven piles due to higher uncertainty in the constructed condition. Additional guidance may be found in ASCE 20-96, ACI 336.1R, PIP STS02380, and PIP STE02465

Construction procedures for cast-in-place piles should be developed in advance with the piling sub-contractor’s advice to address construction issues such as;

- a) Dense reinforcement that is difficult to install in augered-cast-in-place piles, or difficulty in consolidating concrete in drilled piers around dense reinforcement
- b) Grout for augered-cast-in-place piles with sufficient performance to allow adequate time for placement of grout and reinforcement cage
- c) Procedures for field bending of reinforcement, if required
- d) Connections to the structure
- e) Inspection methods and placement of instrumentation such as inspection tubes

**10.4.2.3** *Test pile program*—Number and type of tests to be conducted shall be specified by the geotechnical and structural engineer.

**R10.4.2.3** Economics and the requirement for safety in refrigerated liquefied gas (RLG) tank design will typically justify a comprehensive test pile program to validate the static analysis. The program should include a pile driving simulation to develop the driving criteria, dynamic monitoring to adjust the driving criteria, and an ASTM or similar static load test to validate or finalize the pile design. Depending on the number of piles required, it may be economically justified to perform a pile driving simulation and dynamically monitor installation of selected piles to verify hammer performance and adjust driving criteria. Safety factors and the number of piles tested and monitored may be adjusted based on a reliability analysis that considers the uncertainty in loads and the variability of soil conditions.

**10.4.2.4** *Pile driving effects*

**R10.4.2.4** For large pile groups of closed pipe piles or solid prestressed concrete piles, predrilling may be considered to reduce the driving effort and to reduce heave. The

## CODE

## COMMENTARY

use of open-ended pipe piles will also reduce the heave and lateral movement of an installed pile due to installation of an adjacent one. A driving pattern that moves outward from the center of the pile group should be considered to limit the effect on other piles.

**10.4.3** *Ultimate strength of single piles*

**10.4.3.1** Ultimate strength of single piles shall be based on the results of a geotechnical investigation and one of the following:

- a) Application of generally accepted geotechnical and civil engineering principles to determine ultimate strength of the tip in end bearing, and side friction or adhesion
- b) Static load testing in accordance with ASTM D1143
- c) Other in-place load tests that measure end bearing and side resistance either separately or together
- d) Dynamic testing in accordance with ASTM D4945

**10.4.3.2** Where needed, ultimate axial tensile strength of single piles shall be determined by a test performed in accordance with ASTM D3689.

**10.4.4** *Allowable pile capacity*

**10.4.4.1** Allowable pile service load  $Q_a$  shall be the smaller value determined from:

- a) Structural strength of the pile
- b) Ultimate strength of single piles,  $Q_r$ , divided by minimum factors of safety from Table 10.4.4
- c) Permissible total and differential settlement limits

**Table 10.4.4—Minimum factors of safety for deep foundations**

Ultimate pile strength (as per code section)	Normal operation	Hydrostatic loading	Wind or OBE seismic	SSE seismic
10.4.3.1(a)	3.0	2.4	2.25	1.50
10.4.3.1 (b)	2.0	1.60	1.50	1.10
10.4.3.1 (c)	2.0	1.60	1.50	1.10
10.4.3.1 (d)	2.25	1.80	1.70	1.20

**10.4.4.2** Allowable pile service load  $Q_a$  shall be reduced for group effects, down-drag, and other effects that reduce the strength of piling.

**10.4.4.3** Quality control and construction inspection procedures for piles shall be developed before construction and agreed upon by the structural engineer, geotechnical engineer, contractor, and piling subcontractor.

**10.4.5** *Overtopping effects and uplift*

**10.4.5.1** Analyses shall account for the redistribution of pile loads that is caused by lateral loading on the tank.

**R10.4.4.1** The safety factors in Table 10.4.4 are designed for use with nominal (unfactored) loads, and are intended to account for both the uncertainties in load and resistance in one factor. To avoid the overly conservative practice of simultaneously applying the maximum values of all dead loads, live loads, and environmental loads, the engineer should refer to Table 5.2.2 for load combinations, and Tables 7.2 and 7.3 for load factors.

Minimum safety factors in Table 10.4.4 may be reduced when: 1) justified by the geotechnical investigation and subsequent analysis; and 2) approved by the owner and engineer.



**CODE**

**10.4.5.2** The tendency for gas pressure against the roof to lift the walls shall be considered in determining the need for uplift resistance.

**10.4.5.3** Factors of safety for the axial loads on piles under conditions of lateral loading on the tank and conditions of gas-induced uplift shall be in accordance with Table 10.4.4.

**10.4.6** *Lateral load resistance*

**10.4.6.1** The geotechnical engineer shall provide the necessary soil and pile parameters for analysis.

**10.4.6.2** Sliding resistance of unanchored tanks supported by deep foundations shall comply with minimum factors of safety found in 10.3.4.

**10.4.6.3** Allowable lateral load strength of a pile shall be determined by comparing predicted tank foundation deflections with allowable pile deflections and by limiting the bending stresses in piles.

**10.4.6.4** Tank foundation deflections shall be predicted with a structural analysis that includes tank geometry and stiffness and the soil-structure interaction of the laterally loaded pile foundations.

**10.4.7** *Settlement*

**10.4.7.1** Unless otherwise specified in the project documents, maximum limits for settlements of deep foundations shall comply with 10.3.5.

**10.4.7.2** An estimate of total and differential settlement of single piles and pile groups shall be determined by the geotechnical engineer.

**COMMENTARY**

**R10.4.5.2** Tension (uplift) resistance of piles structurally connected to the pile cap may be considered in combination with the effects of lateral loads.

**R10.4.5.3** Safety factors for piles under tension loading are applicable to soil resistance of piles in compression and tension. Allowable stress levels for piles under load are given by ASCE/SEI 7. The ultimate strength for concrete piles under load is determined in accordance with ACI 350 or ACI 318.

**R10.4.6** The effect of lateral loads on pile foundations should be evaluated. The geotechnical engineer should design the pile, pile group, or both, based on a determination of the lateral deflection of the pile head and distribution of resulting moment and shear along the pile shaft using a method of analysis that takes into account pile-soil elastic interaction, load duration, load repetition, structural restraint at the pile head, and the effect of group action.

Piles are categorized by whether they are short or long. In a short pile, the lateral strength is developed by rotation and the passive resistance of the surrounding soil. In a long pile, the lateral capacity is governed by the moments and stresses in the pile.

Lateral load analysis of piles is typically performed with computer programs using soil input parameters furnished by the geotechnical engineer. Alternatively, this task can be performed by the geotechnical engineer in preparing the report.

**R10.4.6.1** In regions having seismic risk, the need to perform a lateral pile load test in accordance with ASTM D3966 should be evaluated by the geotechnical engineer.

**R10.4.7.1** Deep foundations often cause the tank loads to have influence to a greater depth in the soil than would occur under a shallow foundation. Thus, the compressibility of soil layers at greater depth in the soil section will influence total long-term settlement, and should be addressed.

**R10.4.7.2** The effect of fill on soils where deep foundations are used will cause the potential for additional load on the piles due to negative skin friction. In some instances, the

**CODE****COMMENTARY****10.5—Ground improvement**

Where required, ground improvement methods, materials, and procedures shall be developed by the geotechnical engineer in close cooperation with the structural engineer to increase bearing capacity to support the tank, reduce settlement to within the criteria of this standard, or improve seismic performance of the soils.

**10.6—Foundation details****10.6.1** *Groundwater*

**10.6.1.1** The bottom of the tank shall be above the groundwater table or otherwise protected from contact with groundwater at all times.

**10.6.1.2** Electrical heating conduits and other or exposed metal components of the outer tank bottom material in contact with soil shall meet at least one of the following requirements:

- a) Selected to minimize corrosion
- b) Coated, galvanized, or otherwise protected to minimize corrosion
- c) Provided with a minimum of 3 in. of concrete cover
- d) Where necessary, protected via cathodic protection system

**10.6.1.3** Concrete parts of the outer tank bottom in contact with the soil shall meet the following requirements:

load due to negative skin friction may necessitate lengthening of the piles, increasing the number of piles, or both.

Down-drag effects should be considered in predicting pile settlement. Drag load should be included in determining the required structural strength of the pile. Simple addition of the drag load to the dead load to get total axial load on the pile will often result in overly conservative designs, and is not recommended. For further guidance, refer to Fellenius (2006) and Briaud and Tucker (1997).

**R10.5—Ground improvement**

Soil improvement consists of densifying loose soils or strengthening loose or soft soils. Soil improvement will often be considered for use beneath a tank in two general cases. One case is where the native soils are too loose or soft for a shallow foundation to be adequate, but where the shallow foundation might be adequate if the soils are improved and where the combination is economically competitive with deep foundations. Another case is where deep foundations will be needed, but earthquake-related performance of the soil-foundation-tank system is inadequate without soil improvement.

The following methods should be considered to improve the soil to an acceptable performance level under these circumstances:

- a) Removal of weak material and replacement with suitable fill material
- b) Preloading with overburden to induce settlements
- c) Preloading with overburden combined with improved subsoil drainage, such as wick drains or earthquake drains
- d) Soil improvement through vibrocompaction
- e) Deep soil mixing
- f) Grout injection
- g) Other methods as designed by the geotechnical engineer

**R10.6—Foundation details**

**R10.6.1.2** Cathodic protection does not have to be isolated, but the design should account for all metals and be electrically bonded to the system.

**R10.6.1.3** ACI 222R, Section 4.4.3, notes that the results obtained from the ASTM C1202 test for chloride ion permeability are not always precise and, if concerns exist, should

**CODE**

- a) Constructed of a concrete mixture with a rapid chloride permeability rating of less than 1000 coulombs charge passed as per ASTM C1202
- b) Constructed of a durable concrete mixture as described in 6.6.5.9

**10.6.1.4** The area surrounding the tank shall be graded to drain away from the tank.

**10.6.1.5** Water or spilled refrigerated liquid shall not be allowed to pond adjacent to the tank.

**10.6.1.6** The foundation shall bear at a depth below the shrinking-and-swelling zone or freezing-and-thawing zone, or such soil shall be replaced by compacted select fill.

**10.6.1.7** In freezing-and-thawing zones, the select fill shall be a non-frost-susceptible crushed granular fill.

**10.6.2** *Foundation heating*

**10.6.2.1** *In temperate climates*—that is, areas where there is no permafrost—foundations in contact with the soil shall require a heating system or other method to prevent the 32°F isotherm from penetrating the soil and causing frost heave.

**COMMENTARY**

be accompanied by a petrographic examination of the concrete. ACI 201.2R describes appropriate methods for obtaining durable concrete.

**R10.6.1.4** Drainage away from the tank is important so that surface water and liquefied gasses flow to a drainage sump. This drainage will also aid in preventing a pool fire adjacent to the tank. Though the tank may be in a containment (bund) berm area, it is common practice to have the top of the tank pad at an elevation above the bottom of the containment area.

Consider that the design rainfall events may fill the containment berm (bund) area to an elevation above the level of the bottom of the tank until the water is drained. The heat in the water is likely to prevent damaging icing. The design of the tank foundation and tank appurtenances should consider exposure to water from flooding when appropriate.

**R10.6.2.1** The soil beneath a tank bearing on the ground is prone to losing heat to the tank, and this may lead to freezing of the ground and cause frost heave in temperate climates. Controlling the position of the 32°F isotherm prevents freezing the soil below the tank that can cause frost-heave forces on the base of the tank. Frost heave may be avoided by trace heating the base slab or elevating the base slab, allowing heat input to the foundation through natural air convection.

Air gaps under refrigerated liquefied gas (RLG) tanks are effective to prevent ground freezing instead of foundation heating systems. Heating systems are not required with elevated foundations, having an air gap that prevents ground freezing due to stored RLG. The open height should be sufficient to ensure good airflow even at the end of design life considering long-term settlement.

In areas of permafrost, heating systems will generally not be used and are likely to be detrimental. Ice is not always present, as may be the case of nonporous bedrock, but it frequently occurs and may be in amounts exceeding the potential hydraulic saturation of the ground material. Overlying permafrost is a thin active layer that seasonally thaws during the summer. As in temperate zones, designers often try to maintain the temperature regime in the ground that

## CODE

## COMMENTARY

**10.6.2.2** Heating systems shall be designed to allow functional and performance monitoring.

**10.6.2.3** Details of the heating system shall include provisions for:

- a) Individual replacement of any heating element or temperature sensor
- b) Protection against ingress of water and moisture that can cause galvanic corrosion or other forms of deterioration

### 10.7—Foundation performance monitoring details

**10.7.1** Tank foundations shall be monitored and recorded for settlement before, during, and after the hydrotest in accordance with 10.8.2.1. When settlement monitoring indicates settlement exceeding 75 percent of predefined values, the engineer shall be notified.

existed before site disturbance. Designers should always consult geotechnical engineers knowledgeable in permafrost behavior when building on permafrost.

The designer should consider the risk of a gap under an elevated tank filling with flammable vapor, liquid, or both, in case of a tank leak or a leak from adjacent piping. The air gap space should be designed so that vapor is not trapped in a confined space. The designer should consider U.S. Occupational Safety and Health Administration (OSHA) Standard 29 CFR 1910.146 for confined space entry. The air gap space of individual tanks may or may not qualify as a confined space.

The designer should consider the prevailing winds and airflow in the tank area. The opening for airflow should be sufficient to keep the vapor concentration below 1/2 of the lower explosive limit. Calculations should be made to show that the air gap space and ventilation are sufficient to show that the flame propagation speed is below the speed necessary to cause overpressurization and explosion.

Deflectors may be used to increase airflow under the tank. The air gap should be sufficient to allow adequate airflow and reasonable access under the tank for monitoring and cleaning purposes. The dimensions of the space may be adjusted on agreement of the owner and engineer. The space should remain drained and dry during normal operations.

**R10.6.2.2** In designing a heating system and selecting the bearing depth of the foundation, consideration should be given to the potential for frost heave due to natural freezing of the soil before the heating system is activated. The foundation should bear at a depth that is below the shrinking-and-swelling or freezing-and-thawing zone, or the bearing material should be selected to be unaffected by temperature or moisture changes.

**R10.6.2.3** The heating system should be designed to allow maintenance such as replacing the heating elements or thermal sensors on a routine, in-service basis. Functional and performance monitoring should be performed on a weekly basis as a minimum frequency. Naturally occurring clean coarse sand or gravel will not be susceptible to frost heave as long as it is well drained.

### R10.7—Foundation performance monitoring details

**R10.7.1** Baseline elevations of the tank foundation should be established prior to hydrotesting. Settlement at tank center is measured remotely with inclinometers discussed in 10.7.3 or, in the case of hydrotest, by entering the tank and making a level survey after testing.

As a minimum for tanks where settlement predictions indicate values expected near the limiting values, or wherever the owner specifies, two conduits arranged orthogonally should be cast into the foundation to accommodate settlement-measuring instrumentation, such as inclinometers, and thus provide settlement profiles across the tank bottom.

## CODE

## COMMENTARY

**10.7.2** *Survey points and benchmarks*

**10.7.2.1** A minimum of eight permanent survey points for measuring elevation shall be installed at equal intervals around the periphery of the tank foundation.

**10.7.2.2** Spacing between adjacent survey points shall not exceed 33 ft.

**10.7.2.3** The survey points shall be referenced to at least one external permanent benchmark.

**10.7.2.4** Upon foundation completion and before wall construction, permanent survey points shall be installed and their locations documented.

**10.7.3** *Inclinometers*—Inclinometers shall be installed in the foundation for site classes other than Site Class A (hard rock) or Site Class B (firm rock) as defined in ASCE/SEI 7.

**10.7.4** *Thermal monitoring*

**10.7.4.1** A thermal monitoring system shall be installed in the foundation to monitor the temperature of the foundation to assess the performance of bottom insulation heating system.

**10.7.4.2** The thermal monitoring system shall be monitored to detect adverse cryogenic effects on the ground below the foundation.

During hydrotesting of large tanks, settlement measurements should be made after water filling has reached levels 1/4, 1/2, 3/4, and full. The hydrotest procedure should include the permissible values of settlement for each level of filling for comparison during testing. Differential settlement and tilting should be compared with permissible values at each level with review by the design team if results approach the permissible values. During emptying the hydrotest water, settlement measurements should be made to measure rebound after emptying has reached the 3/4, 1/2, 1/4, and empty levels as a minimum. API 620, Appendix C, provides additional guidance on settlement. API 620, Section Q.8.4, discusses settlement measurements. API 620, Appendix R, discusses settlement measurements in several sections.

**R10.7.2.1** The number of installed survey points should be divisible by four. This allows easy examination of planar cross sections through the tank and comparison with geologic cross sections obtained during the geotechnical investigation.

**R10.7.2.3** External permanent benchmarks should be tied into the international terrestrial reference frame system (ITRF) with a precision of  $\pm 0.01$  ft to provide precise recovery should the permanent benchmark be destroyed or subject to regional settlement.

**R10.7.3** Baseline elevations of the tank foundation should be established prior to hydrotesting. Settlement at tank center is measured remotely with inclinometers discussed in 10.7.3 or, in the case of hydrotest, by entering the tank and making a level survey after testing.

As a minimum for tanks where settlement predictions indicate values expected near the limiting values, or wherever the owner specifies, two conduits arranged orthogonally should be cast into the foundation to accommodate settlement-measuring instrumentation, such as inclinometers, and thus provide settlement profiles across the tank bottom.

## CODE

## COMMENTARY

**10.7.4.3** The thermal monitoring system sensors shall be on a predetermined pattern that covers the bottom surface area.

**10.7.4.4** The conduits holding the thermal monitoring sensors shall allow for ready servicing, removal, and replacement of the thermal sensors.

**10.7.5** *Seismic monitoring*—The seismic response of the RLG tank shall be monitored by triaxial accelerometers mounted at the foundation and the roof of the tank. A third accelerometer shall be located at a free-field site at a distance of at least two tank diameters away from the tank and other major structures.

### 10.8—Monitoring frequency

**10.8.1** All monitoring systems and devices shall be capable of recording outside of normal operation ranges.

#### 10.8.2 *Settlement monitoring*

**10.8.2.1** Tank foundations shall be monitored and recorded at permanently installed benchmark points before, during, and after the hydrotest and periodically during the life of the facility, including during construction, during commissioning, and at least annually during operation. When the settlement monitoring exceeds predefined values, the engineer shall be notified immediately.

**10.8.2.2** Upon foundation completion and before wall construction, the settlement monitoring benchmark points and inclinometers shall be surveyed and documented.

**10.8.2.3** Inclinometers shall be monitored whenever settlement is measured and documented.

#### 10.8.3 *Thermal monitoring*

**10.8.3.1** Thermal system monitoring shall be performed during cool-down and in-service commissioning of the tank, at least weekly.

**R10.7.5** Accelerometers are not required for tanks with SSE peak ground accelerations less than 0.1 g.

### R10.8—Monitoring frequency

**R10.8.2.1** Baseline settlement data should be collected during benchmarking. Additionally, at a minimum, settlement data should be collected at the following construction milestones:

- a) Completion of the base slab, before commencement of the wall construction
- b) Completion of the walls, before the commencement of the roof construction
- c) Completion of the roof construction
- d) Before, during, and after the hydrotest
- e) At the start of cool down

Inclinometers, if installed, should be surveyed at the same time as defined previously.

**R10.8.2.3** Inclinometer measurements should be made within 1 week of the settlement measurements, and preferably on the same day. During the hydrotest, the settlement and inclinometer measurements should be on the same day and with approximately the same liquid level in the tank.

**R10.8.3.1** Thermal system monitoring is recommended to be continuous to detect changes in the insulation and effects on the soil. Sensors should be specified to record the entire range of conditions that the tank will experience from construction, cool-down, in service, warm-up, and end of service, including regional weather extremes. Providing sensors that record particular segments of the potential range for better resolution is permissible and should be considered.

**CODE**

**COMMENTARY**

**10.8.3.2** Evaluations of thermal performance of the foundation and bottom insulation shall be performed at 6 months after the tank is in service, and at least annually thereafter.

**10.8.4** *Seismic monitoring*—The seismic monitoring system shall be regularly maintained at least twice a year at approximately equal time intervals to ensure satisfactory performance during earthquakes.

**10.8.5** *Corrosion monitoring*—Corrosion control monitoring shall be performed twice a year at approximately equal time intervals.

**R10.8.5** Maximum time interval between measurements of 7-1/2 months is usually sufficient to accommodate fill and draw-down schedules.

**10.9—Inspection and testing**

**R10.9—Inspection and testing**

**10.9.1** During construction, all materials testing and performance measurements on the deep foundation components shall be in accordance with project specifications.

**10.9.2** *Inspection*

**10.9.2.1** The actual location in the foundation of each pile, every load of concrete, or component must be documented.

**10.9.2.2** Each lot of straight reinforcing and shape of bent bars and their location in the structure shall be documented and the records shall be readily available as required by 1.2.2.

**10.9.2.3** All mill certificates for lots of reinforcing must be documented.

**10.9.2.4** Mill certificates showing conformity to ASTM standards shall be supplied for steel piles and other steel in the foundation.

**10.9.2.5** Field weld splices shall be performed by welders qualified under AWS D1.1 to use a qualified-by-test or prequalified weld procedure according to AWS D1.1.

**10.9.2.6** All field splices shall be inspected.

**10.9.3** *Testing*

**10.9.3.1** Project specifications shall include requirements for fabrication and nondestructive testing of steel piles.

**10.9.3.2** For concrete placed at the site, the required results shall include truck batch tickets, the results of field tests on fresh concrete, and the results of compression or any other laboratory tests on sample cylinders, beams, cubes, or test specimens.

**10.9.3.3** An independent testing or consulting firm shall inspect the plant for manufacture of precast/prestressed concrete piles for compliance with the prestress concrete industry quality control standards and practices.

**R10.9.3.3** The plant for manufacture of precast/prestressed concrete piles should be certified by the Precast/Prestressed Concrete Institute’s Plant Certification Program in compliance with MNL-116 or equivalent. Concrete piles should be

**CODE****COMMENTARY**

**10.9.3.4** All load tests, dynamic pile driving monitoring, and pile driving records shall be documented and presented to the owner's representative, both in paper copy and electronic files, within 1 day of completion unless otherwise agreed.

**10.9.3.5** To allow ease of search and inspection of all pile testing results by the owner, the engineer, and regulatory bodies, a complete collection of those results shall be provided to the owner's representatives in paper and electronic files.

**10.9.3.6** When maturity method sensor measurements are used in fabricating the piles or any part of the foundation, the results and curves from all sensors shall be documented and provided to the engineer and owner both in paper copy and electronic files.

**10.9.4** *Documentation*

**10.9.4.1** Documentation of all materials testing and performance measurements and results shall be available at all times to the engineers and owners.

**10.9.4.2** All documentation on quality assurance/quality control tests or certifications and locations shall be furnished in paper copy and electronic files suitable to the owner.

**10.9.4.3** Records of all test results shall be preserved and disposition of failed materials documented.

**10.9.4.4** Documentation of all materials testing and performance measurements and results shall be provided in a quality assurance/quality control system delivered in a form(s) acceptable to the engineers, owners, and regulatory agencies.

**10.9.4.5** The quality assurance/quality control system documents shall be detailed to identify precisely which component or material in the structure was tested.

manufactured to ACI 543R, or the equivalent, and certified by the producer that the piles meet the standards.

**R10.9.4** All certifications, quality assurance/quality control records, design drawings, specifications, and construction records of any kind should be assembled by the contractor or owner-designated party in a logical manner that facilitates later recovery and review. The owner should maintain these documents through the life of the facility.



**CODE**

**COMMENTARY**

**CHAPTER 11—CONSTRUCTION REQUIREMENTS**

**11.1—Construction plan**

The project specifications shall include provisions for developing a written construction plan to define construction sequence and methods. The construction plan shall include quality assurance requirements in 11.2.

**11.2—Tolerances**

Tolerances shall be in accordance with ACI 117. Additional requirements listed in 11.2.1 through 11.2.5 shall also be satisfied.

**11.2.1** *Tolerances for cross-sectional dimensions*

**11.2.1.1** *Base slab*—Tolerances in slab thickness are as follows:

- a) +3/8 in. and -1/4 in., where the section thickness is less than or equal to 12 in.
- b) +1/2 in. and -3/8 in., where the section thickness exceeds 12 in. but not over 3 ft.
- c) +1 in. and -3/4 in. for a section thickness exceeding 3 ft

**11.2.1.2** *Walls*

**11.2.1.2.1** Thickness of walls constructed by jump forming shall not vary more than +1/2 in. nor -1/4 in. from the specified thickness

**11.2.1.2.2** Thickness of walls constructed by slipforming shall not vary more than +3/4 in. nor -3/8 in. from the specified thickness.

**11.2.1.3** *Concrete dome roof*—Thickness of concrete dome roofs shall not vary by more than ±1/2 in. from the specified thickness.

**11.2.2** *Variation in roundness*

**11.2.2.1** *Base slab radius*

**11.2.2.1.1** Permissible deviation from specified base slab radius of curvature measured from a center point to the outside face of the base is 0.10 percent of the base slab radius, not greater than 1.5 in. and not less than 0.75 in.

**11.2.2.1.2** Permissible deviation of the base slab radius measured along any 10 ft of circumference is 0.2 percent of the specified base slab radius, not less than 3/4 in., nor more than 2 in.

**R11.1—Construction plan**

A formal construction plan that describes means and methods provides the engineer the opportunity to evaluate proposed construction for compliance with the design. Before construction, full-scale mockups should be considered to ensure plant equipment and labor force can attain required quality.

**R11.2—Tolerances**

In general, tolerances are not cumulative, and the most restrictive tolerances should apply.

**R11.2.1** These tolerances are typically in line with established liquefied natural gas (LNG) and liquefied petroleum gas (LPG) practice.

**R11.2.2.1.1** The base slab radius tolerance defines the global envelope into which the base slab radius has to fit (that is, minimum and maximum radii).

**R11.2.2.1.2** This addresses the local deviation from specified radius that is permitted within the global envelope. Thus, flat spots or greater radius-of-curvature are allowed over a short distance, but the overall slab radius must be maintained within the specified tolerance listed in 11.2.2.1.1. The localized tolerance can be considered to be the deviation of the

## CODE

## COMMENTARY

**11.2.2.2 Tank wall radius**

**11.2.2.2.1** Permissible deviation from specified tank wall radius measured to the inside face of the tank wall shall be as follows:

- a) Bottom of wall: 0.06 percent of the specified wall radius, not greater than 1.0 in. and not less than 0.5 in.
- b) Top of wall: 0.10 percent of the specified wall radius, not greater than 1.5 in. and not less than 0.75 in.
- c) Interpolate tolerances at intermediate levels

**11.2.2.2.2** Permissible deviation of the tank wall radius measured along any 10 ft of circumference is 5 percent of the specified core wall thickness not less than 3/4 in.

**11.2.3 Variation in elevation and level****11.2.3.1 Base slab**

**11.2.3.1.1** The maximum variation from specified elevations for any point on the completed surface, excluding the support underneath the inner tank wall, shall not exceed  $\pm 1/2$  in.

**11.2.3.1.2** The maximum variation from specified elevations for any point on the completed surface, excluding the support underneath the inner tank wall, shall not exceed  $\pm 1/2$  in.

**11.2.3.1.3** The top of concrete support bearings under a concrete wall shall be level within  $\pm 1/4$  in. in any 30 ft circumference, within  $\pm 1/2$  in. in the total circumference, and within  $\pm 1/4$  in. along any radial line.

**11.2.3.1.4** For an inner steel tank or an inner concrete tank with a sliding base, the top of the concrete surface directly under the tank wall-supporting elements shall be level within the following tolerances:

- a)  $\pm 1/8$  in. in any 30 ft circumferential length

local radius-of-curvature (defined by three points in 10 ft of circumference) from the specified radius.

**R11.2.2.2.1** Tolerances for wall tank radius measured at the bottom of the tank wall are typically  $\pm 1$  in. for large-diameter LNG and RLG tanks. To cover the full spectrum of potential tank diameters and to introduce upper- and lower-bound values, the tolerance is set at 0.06 percent of the tank radius  $R$  and upper and lower bounds of 1 in. and 1/2 in., respectively. The 0.06 percent of the tank radius tolerance is applicable to tanks with specified inside radius in the range of 69.5 to 139 ft. For other size tanks, the lower- or upper-bound tolerance will control. Under no circumstances should the target deviation be less than  $\pm 3/4$  in.

ACI 372R, 373R, and 350 state that the “maximum permissible deviation from the specified tank radius at any height should be 0.1 percent of the radius” or 60 percent of the core wall thickness, whichever is less, and should be measured to the inside wall face. In this code, the 0.1 and 0.06 percent tolerances are used at the top and the bottom of the wall, respectively. Interpolating between the two tolerances is acceptable at intermediate heights. This requires more stringent control of tolerances during construction than is permitted for tanks built to the referenced ACI standards.

**R11.2.2.2.2** Permissible deviations from tank wall radius over 10 ft of circumference in this code are the same or similar to ACI 372R, ACI 373R and ACI 350, Appendix G. The core wall is defined as that portion of a concrete wall that is circumferentially prestressed. It does not include the shotcrete covercoat in an externally post-tensioned tank.

**R11.2.3.1.1** This is applicable under concrete tank walls of monolithic construction.

**R11.2.3.1.2** This is applicable for concrete walls supported on bearings.

**CODE**

**COMMENTARY**

- b)  $\pm 1/4$  in. in the total circumferential length
- c)  $\pm 3/16$  in. along any radial line with length equal to the supporting-element width

**11.2.3.2 Walls**—Walls shall be plumb within  $3/8$  in. per 10 ft of vertical dimension.

**R11.2.3.2** The  $3/8$  in. per 10 ft of vertical dimension tolerance is based on ACI 372R, 373R, and 350.

**11.2.3.3 Miscellaneous embedments and openings**

**11.2.3.3.1** Location of the centerline and cross-sectional dimensions of temporary construction access openings shall be within  $\pm 1$  in. of that specified.

**11.2.3.3.2** Unless otherwise specified by the engineer, position of cast-in insert plates measured in the plane of concrete surfaces shall be within  $\pm 1/2$  in. of specified.

**R11.2.3.3.2** Positional alignment should be considered in design and sizing of insert plates for support of appurtenances. For typical attachments such as ladders and pipe support, a larger tolerance may be desirable to aid in construction. When permitted by the engineer, the larger positional tolerances should be considered in sizing and selection of the plate size.

**11.2.3.3.3** Position of cast-in insert plates measured normal to the plane of concrete surfaces shall be within  $\pm 3/16$  in. of specified location.

**11.2.3.3.4** Position of openings and sleeves shall be within  $\pm 1/4$  in. of specified location.

**11.2.4 Vertical metal liner embedment tolerances**

**11.2.4.1** The position of vertical liner embedments shall be within  $\pm 1/4$  in. of specified location measured at the bottom of the wall in the plane of the concrete surface.

**11.2.4.2** Vertical liner embedments shall be plumb within  $\pm 1/2$  in. when measured from the bottom to the top of the wall.

**11.2.4.3** The position of vertical liner embedments shall be flush with the concrete surface or recessed not more than  $1/8$  in. below the concrete surface. Where the embedment surface is recessed, the concrete surface shall be feathered away from the embedment with a 1:16 slope.

**11.2.4.4** Tolerances in 11.2.4.1 and 11.2.4.3 may be increased when considered in design and specified by the engineer.

**R11.2.4.4** Where position of embedments is difficult to achieve, such as with slipform construction, consideration should be given to permitting larger tolerances as an aid to construction. The effect of larger tolerances needs to be considered in design of the embedments, and the permissible tolerances should be specified in the project documents. For slipform construction,  $3/8$  in. for position and offset is recommended.

**11.2.5 Horizontal thermal corner protection embedments**

**11.2.5.1** The elevation of horizontal thermal corner embedments shall be within  $\pm 1/4$  in. from that specified.

## CODE

**11.2.5.2** The position of horizontal embedments shall be flush with the concrete surface or recessed not more than 1/8 in. below the concrete surface. Where the embedment surface is recessed, the concrete surface shall be feathered away from the embedment with a 1:16 slope.

**11.3—Shotcrete for external prestressing systems**

Unless otherwise specified, procedures for shotcrete construction shall comply with ACI 506.2.

**11.3.1** *Proportioning shotcrete*—Proportioning shall provide a 28-day compressive strength of at least 4500 psi.

**11.3.2** *Shotcrete construction procedures*—Procedures for shotcrete construction of primary and secondary containers prestressed with circular wire and strand shall be as specified in ACI 506.2, except as modified herein.

**11.3.3 Shotcrete overcoat**

**11.3.3.1** Externally-applied circumferential prestressed reinforcement shall be protected against corrosion and other damage by a shotcrete overcoat consisting of a wire coat placed on prestressed reinforcement, and a body coat placed on the wire coat. If the wire coat and body coat are placed in a single operation, the mixture proportions shall be those for the wire coat.

**11.3.3.2** Each layer of circumferential prestressed wire or strand shall be covered first with a wirecoat of cement mortar applied by the pneumatic process after prestressing to provide a minimum cover over the wire of 1/4 in.

**11.3.3.3** The wire coat shall be damp-cured by a constant spray or trickling of water down the wall. Curing shall be permitted to be interrupted during continuous prestressing operations. Curing compounds shall not be used on surfaces that will receive an additional wire coat or body coat.

**11.3.3.4** Shotcrete material placed incorrectly shall be removed and replaced.

## COMMENTARY

**R11.3—Shotcrete for external prestressing systems**

Wire coating material is typically made using one part portland cement and not more than three parts fine aggregate by weight. Body coating material is typically made using one part portland cement and not more than four parts fine aggregate by weight. Polypropylene fibers conforming to ASTM C1116 are commonly used in the shotcrete mixture to help mitigate shrinkage cracking.

**R11.3.3.2** ACI 506.2 should be used to develop project specifications. Preconstruction testing should be required to demonstrate adequacy of materials, procedures, and qualifying nozzlemen. The application of shotcrete is material- and workmanship-sensitive, and should comply with the requirements of ACI 350 and ASA CCS-4(08) and recommendations of ACI 372R and ACI 506R.

**R11.3.3.3** Curing of the wire coat should be started immediately after shotcrete placement without damaging the shotcrete. Maintaining the relative humidity naturally or artificially, near or above 95 percent over the shotcrete surface, is an acceptable method of curing in accordance with ACI 506R. Curing compounds applied to intermediate layers of shotcrete may interfere with the bonding of subsequent layers and thus their use is prohibited. The exterior of the tank may be wrapped in plastic to maintain moisture in the shotcrete.

**R11.3.3.4** After the wire coat is in place, visual inspection can immediately determine whether or not proper encasement has been achieved. Where the reinforcement patterns show on the surface as distinct continuous horizontal ridges,

**CODE**

**COMMENTARY**

**11.3.3.5** A body coat providing a minimum of 1 in. cover over the outside layer of prestressed reinforcement shall be applied over the last layer of wire coat. Application of the body coat shall comply with the following:

- a) If the body coat is not applied as a part of the wire coat, laitance and loose particles shall be removed from the surface of the wire coat before the application of the body coat
- b) Positive methods shall be used to establish uniform and correct thickness of shotcrete core in accordance with ACI 506.2
- c) The completed shotcrete coating shall be cured for at least 7 days using methods specified by ACI 506.2.

**11.3.3.6** After the bodycoat has cured, the surface shall be checked for hollow-sounding locations by tapping with a light hammer or similar tool. Such locations indicate a lack of bond between coats and shall be repaired by removal and replacement with bonded shotcrete or by epoxy injection.

**11.4—Post-tensioning**

**11.4.1** All post-tensioning tendons shall be stored and handled to protect them from mechanical, electrochemical, heat, or other damage.

**11.4.2** Cutting of ends of post-tensioning tendons using methods that adversely affect the wedge systems is prohibited.

**11.4.3** Ducts for bonded tendons shall comply with the following:

- a) Be mortar-tight and nonreactive with concrete, tendons, and grout
- b) Ducts for grouted single wire, strand, or bar tendons shall have an inside diameter at least 1/4 in. larger than tendon diameter
- c) Ducts for grouted multiple wire, strand, or bar tendons shall have an inside cross-sectional area at least two times area of tendons
- d) Ducts shall be maintained free of water if members to be grouted are exposed to temperatures below freezing before grouting
- e) Vent holes shall be provided adjacent to the anchorages and at high points of the ducts to assist with air removal
- f) Vertical ducts shall be filled from the bottom
- g) Vertical ducts shall be equipped with standpipes or extensions at the top to provide a head of grout at least 18 in. above the anchor

the shotcrete has not been driven behind the reinforcement and voids can be expected. If, however, the surface is substantially flat and shows virtually no pattern, a minimum of voids is likely.

**R11.3.3.5** Using vertical screed wires is one method used to establish uniform and correct thickness of shotcrete and should be spaced no more than 36 in. apart circumferentially. Wires should be installed under tension, defining the outside surface of the shotcrete from top to bottom. Wires generally are 18- to 20-gauge high-tensile-strength steel wire. Other methods may be used that will provide positive control of the thickness. Automated shotcrete with the nozzle traveling parallel to the surface at a known linear or bidirectional speed ensures uniform coverage and thickness over the entire exterior surface.

**R11.4—Post-tensioning**

**R11.4.2** Wedges can be adversely affected by increased temperatures from cutting methods, such as oxyacetylene flame cutting. Saw cutting or the lower temperature plasma-torch cutting are recommended for removing excess strand at tendon anchors.

**R11.4.3** Vent holes may also be placed at positions recommended by the post-tensioning supplier. The use of standpipes or extensions during grouting of vertical ducts will ensure that there is sufficient fluid grout to offset the bleed water that rises to the top as the grout sets.

## CODE

**11.4.4** *Grouting for bonded prestressing tendons*

**11.4.4.1** Grout for tendons and anchorage assemblies shall be in accordance with ACI 350, Section 18.18. Grouting of tendons and anchorage assemblies shall be carried out as promptly as possible after tensioning. The total exposure time of the prestressing tendon (other than in a controlled environment) before grouting shall not exceed 30 days, nor shall the period between tensioning and grouting exceed 7 days unless precautions are taken to protect the prestressing steel against corrosion.

**11.4.4.2** The project specifications shall include requirements for performance testing of grout materials and grouting procedures to demonstrate that tendon ducts are free of voids and that tendon strands are fully encapsulated in grout. As part of the quality assurance plan, a program to check and record horizontal tendons for voids when grout caps and fittings are removed shall be required.

**11.4.4.3** Portland cement grout shall conform to the following:

- a) The minimum compressive strength of grout shall be not less than 5000 psi at 28 days in accordance with ASTM C109.
- b) Cement for grouting operations shall be Type I or Type II in accordance with ASTM C150. Cement used in the work shall be the same as that on which selection of grout proportions was based.
- c) Water content shall be the minimum necessary for proper pumping of the grout. The water-cementitious material ratio ( $w/cm$ ) shall not exceed 0.45 by weight.
- d) Sand, if used, shall conform to ASTM C144 except that gradation shall be permitted to be modified as necessary to obtain satisfactory workability.
- e) Admixtures conforming to ASTM C494 and known to have no injurious effects on grout, steel, or concrete shall be permitted. Calcium chloride shall not be used.
- f) Bleeding of the grout shall not exceed 2 percent of the volume for the first 3 hours after mixing, nor 4 percent

## COMMENTARY

**R11.4.4** Grout provides bond between the post-tensioning tendons and the concrete and, by which, corrosion protection of the tendons. Proper grout and grouting procedures therefore play an important part in post-tensioned construction (PTI 2006).

**R11.4.4.1** Grout provides bond between the post-tensioning tendons and the concrete and provides corrosion protection of the tendons. Proper grout and grouting procedures therefore play an important part in post-tensioned construction (PTI 2006).

**R11.4.4.2** Full-scale grouting tests using a mockup should be performed on the horizontal and vertical tendons to specifically demonstrate the suitability of the selection of tendon and distribution of vent tubes and selection of pumping equipment. After the grouting trials, the tendon should be cut transversely and inspected at selected locations before commencement of grouting operations on the structure. The grouting trials should ensure the following:

- a) The grout has not shrunk away from the duct wall or strands, thereby creating voids within the system.
- b) The grout has the correct flow characteristics to reach each of the vent points (where provided) and to completely fill the duct.
- c) The theoretical grout consumption.

Visual examination of grout caps and fittings is a good indication of whether horizontal tendon ducts are fully grouted. Connecting an oil-free air supply to the grout fitting on one end and checking the other for airflow is a means of checking for the presence of continuous voids.

**R11.4.4.3** The limitations on admixtures in ASTM C494 apply to grout. Substances known to be harmful to prestressing tendons, grout, or concrete are chlorides, fluorides, sulfites, and nitrates. Aluminum powder or other expansive admixtures, when approved, should produce an unconfined expansion of 5 to 10 percent. Neat cement grout is used in almost all building construction. Only when large ducts have large void areas should the advantages of using finely graded sand in the grout be considered. Admixtures are generally used to increase workability, reduce bleeding and shrinkage, or provide expansion. This is especially desirable for grouting of vertical tendons.

## CODE

total at any time. All separated water shall be reabsorbed within 24 hours.

**11.4.4.4** Epoxy grout shall conform to the following:

- a) Epoxy grout shall be moisture-insensitive with a minimum compressive strength of 125 percent of the design concrete compressive strength.
- b) Epoxy grout shall have demonstrated by tests or experience to exhibit acceptable pumpability.

**11.4.5** *Grout proportions*

**11.4.5.1** Grout shall consist of portland cement and water; portland cement, sand, and water; or a 100 percent solids, two-component epoxy resin system.

**11.4.5.2** Proportions of materials for grout shall be based on either of the following:

- a) Results of tests on fresh and hardened grout before beginning grouting operations
- b) Prior documented test results with similar materials and equipment and under comparable field conditions

**11.4.5.3** Water shall not be added to increase grout flowability that has been decreased by delayed use of grout.

**11.4.6** *Grout mixing and pumping*

**11.4.6.1** Grout shall be mixed in equipment capable of continuous mechanical mixing and agitation that will produce uniform distribution of materials passed through

## COMMENTARY

**R11.4.5.1** Past success with grout for bonded prestressing tendons has been with portland cement as the cementing material. A blanket endorsement of all cementitious materials (defined in Chapter 4) for use with this grout is deemed inappropriate because of a lack of experience or tests with cementitious materials other than portland cement, and a concern that some cementitious materials might introduce chemicals listed as harmful to tendons in ACI 350, Section R18.18.2. Thus, portland cement in ACI 350, Section 18.18.1 and water-cement ratio ( $w/c$ ) in 18.18.3.3 are retained in this edition of the code.

Epoxy grout has been used in limited applications. Caution is recommended in its selection and use. Properties of the material should be reviewed, including differences in the coefficient of thermal expansion and heat generation.

**R11.4.5.2** Grout proportioned in accordance with these provisions will generally lead to 7-day compressive strength on standard 2 in. cubes in excess of 3000 psi, and 28-day strengths of not less than 5000 psi. The handling and placing properties of grout are usually given more consideration than strength when designing grout mixtures.

**R11.4.6** In an ambient temperature of 35°F, grout with an initial minimum temperature of 60°F may require as much as 5 days to reach strength of 800 psi, the minimum strength at which damage from freezing temperature is unlikely to occur. A minimum grout temperature of 60°F is suggested because it is consistent with the recommended minimum temperature for concrete placed at an ambient temperature of 35°F. Prepackaged fast-setting grouts, when approved, may require shorter periods of protection and the recommendations of the suppliers should be followed. Test cubes should be cured under temperature and moisture conditions as close as possible to those of the grout in the member. Grout temperatures in excess of 90°F will lead to difficulties in pumping.

## CODE

## COMMENTARY

screens and pumped in a manner that will completely fill tendon ducts.

**11.4.6.2** Temperature of members at time of grouting shall be above 35°F and shall be maintained above 35°F until compressive strength of at least 800 psi is achieved.

**11.4.6.3** Grout temperatures shall not be above 90°F during mixing and pumping.

**11.4.7** *Protection of prestressing tendons*—Burning or welding operations in vicinity of prestressing tendons shall be carefully performed so that tendons are not subject to excessive temperatures, welding sparks, or ground currents.

**11.4.8** *Application and measurement of prestressing force*

**11.4.8.1** Prestressing force shall be determined by both of the following methods:

- a) Measurement of tendon elongation—required elongation shall be determined from average load-elongation curves for the prestressing tendons used.
- b) Observation of jacking force on a calibrated gauge or load cell or by use of a calibrated dynamometer.

The cause of any difference in force determination between a) and b) that exceeds 12 percent shall be ascertained and corrected.

**11.4.8.2** Total loss of prestress due to unreplaced broken prestressing steel shall not exceed 2 percent of total prestress.

**11.4.9** *Prestressing sequence*

**11.4.9.1** The stressing sequence shall be developed so as to minimize bending and shear stresses within the tank wall.

**11.4.9.2** Effects of tendon stressing sequence shall be included in the design of wall and foundation. At construction access openings, the stressing sequence shall be evaluated to ensure the resulting concrete precompression is within acceptable limits established for the design.

**11.4.10** *Anchorage*—Where prestressing steel is not developed by bond at design cross sections, anchorages shall

**R11.4.8.1** ACI 350, Section 18.20.1 discusses the basis for the 7 percent tolerance in tendon force determined by gauge pressure and elongation measurements for post-tensioned construction.

**R11.4.8.2** This provision applies to all prestressed concrete members. For cast-in-place post-tensioned slab systems, a member should be that portion considered as an element in the design, such as the joist and effective slab width in one-way joist systems, or the column strip or middle strip in two-way flat plate systems.

**R11.4.9.1** The stressing sequence for vertical cylindrical tanks should be evaluated to ensure that large shear and bending forces do not develop during tendon stressing. Except for those passing through access openings, vertical tendons should be stressed before the hoop tendons to attain maximum shear and flexural strength. To minimize shear and flexure associated with stressing hoop tendons, it is customary to stress the even tendons followed by the odd tendons (or vice versa).

**R11.4.9.2** Determining the prestressing sequence to achieve required concrete precompression at construction access openings usually involves complex analyses that should be considered early in the design.

**R11.4.10** Test results for specific anchorages should be obtained from post-tensioning suppliers. Where records of tests cannot be furnished, then scale testing of the proposed



**CODE**

**COMMENTARY**

be qualified for the service temperatures to which they are exposed.

anchorages should be undertaken. Refer to AGA (1992) for additional information.

**11.5—Winding of prestressed reinforcement: wire or strand**

**R11.5—Winding of prestressed reinforcement: wire or strand**

**11.5.1** *Qualifications*—The stressing system used shall be capable of consistently producing the specified stress at every point around the wall within a tolerance of  $\pm 7$  percent of the specified initial stress in each wire or strand.

**R11.5.1** Winding should be under the direction of a supervisor that has technical knowledge of prestressing principles and experience with the winding system being used. The stressing tolerance of  $\pm 7$  percent of initial stress is based on ACI 372R.

**11.5.2** *Anchorage of wire or strand*—Each coil of prestressed wire or strand shall be anchored to adjacent wire or strand, or to the wall surface, to prevent loss of prestress in case of a break during wrapping.

**11.5.3** *Splicing of wire or strand*—Ends of individual coils shall be joined by mechanical splicing devices qualified for service temperatures, and shall develop the specified tensile strength of the reinforcement.

**11.5.4** *Concrete or shotcrete strength*—The measured axial compressive strength of concrete at time of stressing shall be at least 1.8 times the maximum initial prestressing force acting in any wall section.

**11.5.5** *Stress measurement and wire or strand winding records*

**R11.5.5.1** Readings of the force in the prestressed reinforcement in place on the wall should be made when the wire or strand has reached ambient temperature. All such readings should be made on straight lengths of prestressed reinforcement without deflecting the wire or strand.

**11.5.5.1** A calibrated stress-recording device that can be readily recalibrated shall be used to determine stress levels in prestressed reinforcement throughout the wrapping process. At least one stress reading for every coil of wire or strand, or for each 1000 lb of wire or strand, or for every vertical foot of wall per layer, shall be taken after the prestressed reinforcement has been applied on the wall.

Through the use of continuous electronic force measurement and correction, a more stringent force tolerance is achievable. Continuous electronic readings should be made along the full length of the wire or strand. Continuous electronic force readings are usually performed in conjunction with mechanical prestressing methods.

A written or continuous, electronically-generated record of stress readings, including location and layer, shall be maintained. This submission shall be reviewed before acceptance of the work. Continuous electronic recordings taken on the wire or strand in a straight line between the stressing head and the wall shall be used in place of the above when the system allows no loss of tension between the reading and final placement on the wall.

**11.5.5.2** The total initial prestress force measured on the wall per vertical foot of height shall be not less than the specified initial force in the locations indicated on the design force diagram and not more than 5 percent greater than the specified force.

**11.6—Forming**

**R11.6—Forming**

**11.6.1** *Design and fabrication*

**R11.6.1** The type of formwork systems used for tank construction can vary and can include conventional formwork, jump-forming, slipforming, metal leave-in-place

**CODE**

**11.6.1.1** Formwork shall be designed and fabricated to produce a structure that will conform to the correct dimensions, shape, elevation, and position within permissible tolerances. Forms shall be provided with ties and bracing to prevent mortar leakage and excessive deflection.

**11.6.1.2** Design of formwork systems shall include consideration of:

- a) Construction loads including impact, and expected environmental loads
- b) Rate and method of placing concrete
- c) Work platforms and scaffolding to provide access for construction activities and inspection
- d) Protection of concrete during the curing period
- e) Form removal and handling to prevent damage to previously placed concrete and components

**11.6.2** *Wall forms*

**11.6.2.1** For containments without a leak-tight liner, the form tie assemblies and methods of patching tie holes shall be suitable for providing a liquid-tight structure meeting the performance requirements of 6.2.2 for primary containments and 6.2.3 for secondary containments.

**11.6.2.2** Slipforming is only permitted when approved by the engineer. Design and fabrication of slipforms shall comply with 11.6.1 and approved methods for:

- a) Determining and controlling level at each jack unit
- b) Controlling placement of reinforcement, prestressing system components, and embedments to meet specified tolerances
- c) Determining and controlling alignment, shape, and thickness of concrete to meet specified tolerances

**11.6.2.3** Where wall construction is by continuous slipforming, a plan approved by the engineer for the supply and placement of concrete, and installation of reinforcement and embedments shall be developed.

**COMMENTARY**

forms, or a combination of these. Guidance on formwork systems can be found in ACI 347 and Hurd (2005).

**R11.6.1.2** Requirements for design and fabrication in 11.6.1 are based on ACI 350, Section 6.1.

**R11.6.2.2** Slipforming, when performed continuously, provides a means to eliminate construction joints, and this is a desirable form of construction where a metallic vapor barrier is not used to achieve liquid tightness. Some requirements for slipforming are included in ACI 347.

**R11.6.2.3** Slipforming operations involve a large number of people in a limited amount of space, working at different levels simultaneously. This requires significant attention to detail at the planning stage. Therefore, mockups and trials of heavy reinforced structural elements should be considered before construction.

Before placing concrete in the forms, a detailed checklist for start-up slipform operations should be completed. Planning should also include worker requirements, working tasks and responsibilities, and guiding of the slipform. Consideration should be made for checking that sufficient equipment, spare parts, and consumable goods are available. Along with this planning, backup solutions should be worked for all possible errors or faults that may occur.

Where excessive delay is encountered in vertical slipforming such that setting of the concrete is approaching the top surface of the concrete, consideration should be given to using chemical retarders to delay the setting of the surface. The unhardened binder on the surface can then be washed away, leaving a rough surface for the bonding when slipforming operations resume.

## CODE

**11.6.2.4** Backup systems shall be incorporated, including craneage and equipment for the slipform (additional pumps, hoses, and jacks).

**11.6.3** *Placement and consolidation*—The project specifications shall include provisions for concrete construction to include:

- a) Preparation of equipment and place for deposit
- b) Mixing, conveying, and depositing
- c) Curing and protection
- d) Procedures for cold weather or hot weather concreting

### 11.7—Construction joints

**11.7.1** Location and details of construction joints shall be considered in design of the structure and shall be shown on the contract documents.

**11.7.2** Before fresh concrete is placed against a construction joint, it shall be cleaned and laitance removed. Where reliance is placed on concrete alone for leak tightness, the surface of construction joints shall be roughened to a minimum amplitude 1/4 in. The final roughened surface shall be clean and all laitance and loose material removed. Before placement of new concrete, a final cleaning with high-pressure water shall be performed.

**11.7.3** Before new concrete is placed, all construction joints shall be wetted to be in a saturated surface-dry condition. Freestanding water shall be removed before commencement of concreting operations.

**11.7.4** Construction joints shall be so made and located as not to impair the strength of the structure. Provisions shall be made for transfer of shear and other forces through construction joints.

### 11.8—Concrete embedments

Concrete embedments shall be detailed on the contract documents. Requirements of ACI 350, Section 6.3, shall be satisfied.

## COMMENTARY

**R11.6.3** ACI 309R describes various methods of consolidation and ways that the consolidation can be evaluated for effectiveness.

### R11.7—Construction joints

Construction joints are defined as concrete surfaces, upon or against which concrete is to be placed and to which new concrete is to adhere, that have become so rigid that the new concrete cannot be incorporated integrally by vibration with that previously placed. For precast construction, the vertical joints should be pumped from bottom to top.

**R11.7.1** Details for unplanned construction joints should be considered during the design phase in preparation for an event that may occur where concrete placement has to stop for an extended period during a concrete pour.

**R11.7.2** The surfaces of concrete at all construction joints should be prepared as called for in ACI 301.

**R11.7.3** Wetting the surface before placing concrete avoids drawing of moisture from the concrete mixture and weakening the joint.

**R11.7.4** The location of construction joints is typically governed by construction limitations such as form height for walls or concrete delivery strength rather than consideration of structural loads. Where practicable, construction joints should be located in regions of low shear.

Lateral force design may require design treatment of construction joints. Shear keys, intermittent shear keys, diagonal dowels, or the shear-friction method of design in ACI 350 may be used for transfer of shear forces at construction joints.

**CODE****COMMENTARY****11.9—Coatings**

**11.9.1** Before application, concrete surfaces shall be grit-blasted or otherwise treated to make them compatible with the coating system.

**11.9.2** Coatings placed on the inside surface of the secondary (outer) container shall be protected from damage during the placement and vibration of the insulation.

**11.10—Welding**

**11.10.1** Procedures for welding steel components and steel reinforcement connections or splices shall be in accordance with written Weld Procedure Specifications (WPS) performed by qualified welders.

**R11.10—Welding**

**R11.10.1** Welding is only to be performed by qualified welders in accordance with a WPS for the type of weld being made. A WPS can be based on those permitted in ANSI/AWS D1.1. Project requirements for developing a WPS should comply with ASME B31.3 or AWS B2.1 for structural welding, and AWS D1.1 requirements for welding of steel reinforcement. Project requirements for procedures for welding of steel plate elements and associated welder qualification should be based on API 620, 6.7 and 6.8.

**CODE**

**COMMENTARY**

**CHAPTER 12—COMMISSIONING/  
DECOMMISSIONING**

**12.1—Scope**

These provisions shall apply to all the components of the containment systems that are affected by the commissioning operations.

**12.2—Testing**

**12.2.1 General**—Unless otherwise specified in the contract documents, testing of concrete containers shall include:

- a) Hydrostatic testing in accordance with 12.2.4 of primary containers
- b) Liquid tightness testing in accordance with 12.2.5 of primary containers
- c) Pneumatic testing in accordance with 12.3.1 of primary and secondary containers forming a part of the vapor containment

**12.2.2** A written procedure to be followed shall be prepared in advance of testing, to include:

- a) Responsibility and duties of operation and supervisory personnel
- b) Safety procedures
- c) Test limits and the stepwise position (open/closed) of all valves required to isolate the tank and to perform the required tests
- d) Instrumentation to be installed and monitoring to be performed
- e) Checklists and sign-off forms for recording the test results and test acceptance

**12.2.3** Hydrostatic, pneumatic, and liquid tightness testing shall be completed before application of insulating materials over surfaces requiring visual inspection during testing.

**12.2.3.1** Hydrostatic testing shall not be performed before:

**R12.1—Scope**

The term “commissioning” is used to denote the tests (hydrostatic and pneumatic) that must be conducted before placing the tank into service in addition to the start-up procedures such as purging into service and cool-down. Decommissioning denotes the purging of the tank out of service, and the subsequent warm-up and the introduction of air.

**Concrete primary containers:** When the concrete component is part of the primary containment, the testing criteria are nearly similar to those for all-metal primary tanks, but with certain modifications that reflect the properties and behavior of concrete.

**Concrete secondary containers:** With few exceptions, the commissioning of the secondary container is independent of whether the primary container is constructed of metal or concrete. The provisions of this chapter are intended to highlight commissioning of all cases.

**R12.2—Testing**

**R12.2.1** The provisions of this section apply for hydrostatic testing, commonly called hydrotest of the inner or primary containment for RLG tanks. With few exceptions, when the concrete component is part of the secondary containment only, and metal is used as the primary liquid containment, the criteria for testing, purging, cool-down, and decommissioning procedures are similar to those for all metal tanks. Hydrotesting of secondary containment is not customary, but the provisions of 12.2.4 are also applicable for testing the secondary containment when it is required.

Hydrostatic and pneumatic testing is performed to demonstrate structural integrity of the container and its anchorage, bottom insulation, and foundation components before filling with refrigerated liquefied gas (RLG). These tests are also part of testing performed to demonstrate liquid tightness.

## CODE

## COMMENTARY

- a) Concrete materials have reached specified strength and age
- b) Prestressing installation, grouting, and, if specified, concrete protection is completed
- c) Concrete quality assurance tests are completed
- d) Inspection and testing of welded joints of metal liners, penetrations, and piping is completed
- e) Corrosion protection of metal surfaces, if required, is complete

**12.2.3.2** Hydrostatic testing shall be performed in a manner that does not result in permanent structural or containment deterioration of the tank or metallic components that come into contact with the hydrotest fluid.

#### **12.2.4** *Hydrostatic testing*

**12.2.4.1** The contract documents must define the test loads that were considered in the design.

**R12.2.4.1** Hydrotest is one of the load conditions considered for prestressing. A partial hydrotest should not govern the prestressed concrete design. In the case of full-height hydrotest, it might govern the prestressed concrete design.

Hydrostatic testing to the design liquid level is recommended where foundation conditions permit. Otherwise, the recommended test water height is that corresponding to 1.25 times the product load (test water height of 1.25 times the product specific gravity times the design liquid level).

The water test height is limited by consideration of the following:

- a) Design liquid level of the stored RLG
- b) Height corresponding to the allowable temporary test load that may be exerted on foundation components and bottom insulation
- c) Height corresponding to the structural limits of any part of the concrete containment

**12.2.4.2** For closed-top tanks, the test shall consist of filling the tank with water to the specified test height and applying an overload air pressure of 1.25 times the pressure for which the vapor space is designed.

**12.2.4.3** The tank shall be vented to the atmosphere during filling and emptying with water.

**12.2.4.4** Before hydrotesting, all accessible surfaces that can affect the integrity of the tank shall be visually inspected for signs of corrosion, pitting, or degradation.

**12.2.4.5** The period for the completion of the hydrotest, in general, shall not exceed 30 days unless previously agreed to by the owner.

**12.2.4.6** All surfaces of the primary concrete tank exposed to seawater during the test shall be spray-saturated to a saturated surface-dry condition using fresh water before the hydrotest.

**R12.2.4.5** This period is defined as fill, test, empty, wash, and clean and dry time. The duration of the test should be kept to a minimum.

#### **12.2.5** *Liquid tightness*

CODE

COMMENTARY

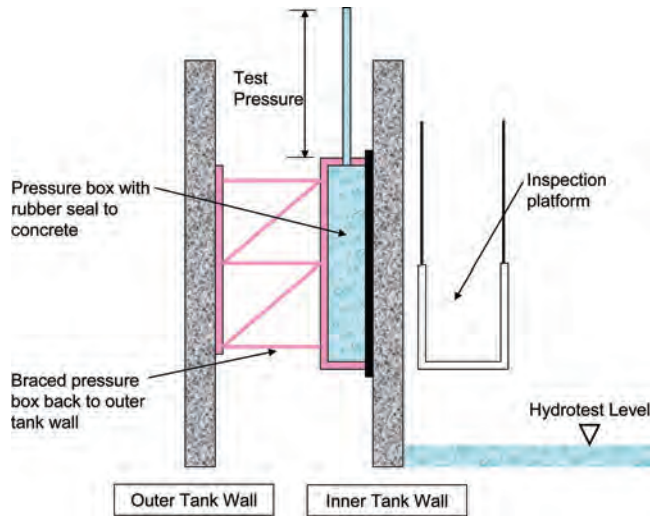

Fig. 12.2.5.1(a)—General layout of external pressure box test.

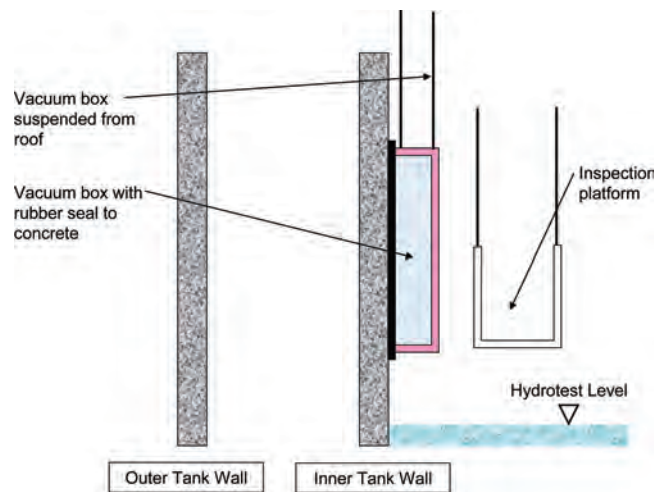

Fig. 12.2.5.1(b)—General layout of internal vacuum box test.

**12.2.5.1** The entire height of a primary container to be exposed to refrigerated liquid, including the overfill allowance, shall be tested for liquid tightness. The liquid tightness evaluation can be performed by:

- a) Filling the primary container and the overfill allowance completely with water
- b) Depending on the project requirements, the depth of the test water for partial hydrotests (tests that specify the test level lower than defined in a)) is determined by multiplying the product hydrostatic pressure by a factor greater than or equal to 1.0 and determining an equivalent depth of water. In all cases of partial hydrotesting, the entire inside surface of the primary container above the hydrostatic test fill level needs to be tested with other methods to confirm liquid tightness. These methods include:

**R12.2.5.1** Relevant NDT is presented in ACI 228.2R.

## CODE

- 1) Local pressure/vacuum testing, such as external/internal pressure-box testing and internal vacuum box testing, as shown in Fig. 12.2.5.1(a) and 12.2.5.1(b)
- 2) Nondestructive testing (NDT)

**12.2.5.2** Testing for liquid tightness of primary concrete containers without liners shall include one or more of the following:

- a) Below the hydrostatic test water level, visual inspection shall be used to check for leaks and wet spots
- b) Local pressure/vacuum testing shall be used above and below hydrostatic test water levels. Unless otherwise specified in the contract documents, local pressure/vacuum testing is required only at construction joints, penetrations, and embedments
- c) Nondestructive testing procedures specified and approved by the owner

**12.2.5.3** Testing for leak tightness of the secondary containers is not required.

**12.2.6 Anchorage**—Where anchorage is provided that requires tightening of individual anchors, tightening shall be in accordance with procedures defined by the designer. Unless otherwise specified, anchor tightening shall be performed:

- a) During the hydrotest, with the primary tank filled at the maximum water level
- b) Before the pneumatic testing of the secondary container  
Anchorage shall be visually inspected before and after testing.

## COMMENTARY

**R12.2.5.2** The relationship between hydrotesting and NDT techniques should be defined by performing NDT over parts of the tank that are also hydrotested. The supplemental techniques should:

- a) Be capable of identifying cracks that are perpendicular to the wall surface, such as through-thickness cracks
- b) Be capable of identifying other material discontinuities that adversely affect tank performance, such as presence of voids, honeycombing, or both
- c) Have the ability to cover large areas in a cost-effective and time-efficient manner

Numerous NDT techniques can be used for evaluating cracking/microcracking and identifying material discontinuities in concrete tanks walls (ACI 228.2R). For instance, impact-echo and ultrasonic pulse velocity are commonly used for crack location. Ground-penetrating radar, impulse response, and ultrasonic pulse velocity are commonly used for detecting honeycombing and voids. Impulse response, impact-echo, and ultrasonic pulse velocity are well suited for identifying delamination and debonding. Some of the NDT that seems particularly well suited for identifying through-thickness cracks include the crosshole sonic logging (CSL) technique (Hollema and Olson 2003; ASTM D6760), and the spectral analysis of surface wave (SASW) technique (Klysz et al. 2004).

It should be noted that defects in the concrete that result in leakage of test water may self-heal within 3 to 5 days or slightly longer due to the process of autogeneous healing of concrete, provided the crack is not too large (Edvardsen 1999). Cracks that do not self-heal will need to be repaired using an appropriate procedure.

The test for liquid tightness by hydrotest also determines structural integrity of both the bottom of the wall and the critical wall-to-base joint. The foundation design is governed by the hydrotest. The hoop prestressing requirements, however, are usually not governed by the hydrotest.



**CODE**

**COMMENTARY**

**12.2.7** *Quality of test water*—The test water shall be clean and shall include suitable corrosion inhibitors. Use of clean seawater for hydrotesting of primary containers is permitted; however, the following criteria shall be met whether using potable, brackish, or seawater for the hydrotest:

- a) Test water shall be filtered to remove solids and prohibit introduction of significant quantities of marine life and debris into the tank
- b) No hydrogen sulfide is allowed in water
- c) Water pH shall be between 6 and 8.3
- d) Water temperature shall be below 120°F
- e) For austenitic stainless steel components, the chloride content of the water shall be below 50 ppm
- f) For aluminum components, the mercury content of the water shall be less than 0.005 ppm, and the copper content shall be less than 0.02 ppm

If the primary container is to be tested with nonpotable water such as brackish water or seawater, all surfaces of the primary concrete tank exposed to the test water shall be spray saturated to a saturated surface-dry condition using potable water before the hydrotest.

**12.2.8** *Corrosion protection*—The following requirements shall be followed to prevent corrosion and pitting of the tank materials and associated metal components:

- a) Test water sampling, corrosion, and pitting tests shall be conducted using the actual test water from the site before hydrotest.
- b) All metal surfaces that will come in contact with test water shall be fully protected against corrosion using proven means documented by an approved corrosion protection plan.
- c) When required for corrosion protection, all weld seams and associated heat-affected zones (HAZs) shall be cleaned, prepared, and coated with an approved primer after completion of all required NDT inspections. Previously primed abraded areas shall also be repaired and reprimed.
- d) When brackish water or seawater is used, the stainless steel components shall be completely coated on all exposed surfaces with an approved coating during the entire hydrotest cycle. Alternatively, stainless steel components shall be permitted to be installed after the hydrotest unless fully protected by other proven means.
- e) The metal primers shall have proven adhesive performance characteristics suitable for cyclic exposures to cryogenic conditions. Any primer that cannot be demonstrated to have the required adhesion performance shall be stripped after the hydrotest.

**12.2.9** *Tank preparation after hydrotest*

**12.2.9.1** Cleaning and drying of the tank shall be in accordance with owner-prescribed approved procedures.

**R12.2.7** The USEPA (2002) has the following limits:

- a) Chloride limit is less than 250 ppm or mg/L
- b) Copper limit is less than 1 ppm or mg/L
- c) Mercury limit is less than 0.002 ppm or mg/L

Corrosion inhibitors may impact disposal options of test water and should consider local environmental regulations for discharge. The use of seawater as the liquid for the hydrotest in RLG tanks poses a unique set of challenges. Brackish or seawater contains substances that can cause corrosion during the hydrotest if proper precautions are not taken. It should be noted that a chloride content less than 50 ppm is difficult to achieve.

**R12.2.8** The following techniques may be used to provide adequate corrosion protection:

- a) Prime coating with an approved primer
- b) Impressed current cathodic protection
- c) Other proven methods

The primer used for coating shall have proven adhesive performance characteristics suitable for cyclic exposures to cryogenic conditions or must be stripped off after the hydrotest. If hydrotest water is left in the tank for less than 3 weeks, 9 percent nickel surfaces may be left bare, provided they are thoroughly washed and dried after the hydrotest. If hydrotest water is left in the tank for an extended period, the engineer should make special provisions to minimize corrosion.

ASTM G46 should be used for evaluating the effects or potential for pitting corrosion.

ASTM G16 may be used for applying statistical analysis to corrosion data. The procedure to be used, areas to be tested, and the acceptable corrosion and pitting limits should be agreed upon by the engineer, owner, and contractor before the hydrotest is performed, subject to the criteria of 12.2.

## CODE

## COMMENTARY

**12.2.9.2** After hydrotesting and dewatering of the tank, all tank surfaces and metal components shall be visually inspected for signs of corrosion, pitting, or degradation.

**12.2.9.3** The entire surface of the inner tank or component and all internals exposed to seawater shall be high-pressure spray-washed with potable water within 24 hours after the hydrotest to remove any sodium chloride residue from the surfaces before these surfaces dry.

**12.2.9.4** For concrete tanks, all surfaces of the inner tank walls and floor shall be high-pressure spray-washed with potable water within 24 hours after the hydrotest is complete.

**12.2.9.5** The high-pressure spray shall use clean, suitable water with less than 250 ppm of chlorides. The washing shall be performed with a high-pressure (greater than 2500 psi) spray. The tank shall be dried after washing.

**12.2.9.6** All surfaces of the inner concrete tank walls and floor tested with brackish or seawater shall be brush-scrubbed after the initial high-pressure spray wash to remove any salt accumulations. A second high-pressure rinse with potable water shall be applied after the brushing operation.

### 12.3—Pressure and vacuum testing

### R12.3—Pressure and vacuum testing

#### 12.3.1 *Pressure testing*

**12.3.1.1** Pneumatic testing shall be permitted to be performed concurrently or separately from the hydrotest.

**12.3.1.2** A test pressure of 1.25 times the pressure for which the tank vapor space is designed shall be applied and held for a 1-hour minimum.

**12.3.1.3** The test pressure shall then be reduced to the tank design pressure, and inspection for leaks shall be performed at all openings, penetrations, and construction joints.

**12.3.2** *Pressure and vacuum relief testing*—Proper functioning of all pressure and associated sensing systems and tank vacuum relief valves shall be verified before the tank is placed into operation. The pressure and vacuum in the tank shall be monitored at all times during the testing using instruments with alarm settings to prevent excess pressure or vacuum conditions. Proper operation shall be confirmed by:

- a) Relief valves—increase the pressure in the vapor space to check the opening pressure of the relief valves
- b) Vacuum valves—create a partial vacuum using a vacuum pump or by withdrawing water from the tank to check the lifting of the vacuum valves

**12.3.3** After the operation of the pressure relief system has been verified, in-place component testing of the relief valves and vacuum valves can be tested by applying test gas

**R12.3.2** During pressure and vacuum relief valve testing, pressure/vacuum levels should be closely monitored for overpressure and excess vacuum. A fail-safe system (for example, U-tube) should be provided to prevent excessive development of pressure or vacuum. Verifying proper functioning of the relief valve system includes ensuring that the pressure drop in the sensing line does not cause premature reseating of the valves.

After the tank is commissioned, routine individual in-place testing of the tank relief and vacuum breaker valves should be in accordance with plant operating procedures.

**CODE**

**COMMENTARY**

or vacuum to the valve sensing line. The set point of controls shall be calibrated with a dead-weight tester.

**12.3.4** Pumpwells shall be tested in accordance with ASME B31.3. The pump wells' design pressure shall be at least the maximum pump discharge pressure.

**12.4—Purging into service**

The provisions of this section shall apply when the inner (primary) container is concrete or metal.

**12.4.1** Purging shall be a continuous, uninterrupted operation using nitrogen gas with positive pressure maintained within the tank until the start of cool-down.

**12.4.2** Before beginning the purging operation, a complete purging procedure shall be developed including the following:

- a) Nitrogen purge-gas quality specifications and source of supply
- b) Identification of piping connections
- c) Preparation and approval of equipment and instrumentation, including the stepwise position (open/closed) of all valves required to isolate and purge the tank
- d) Assignment and duties of operation and supervisory personnel
- e) Removal of all standing water and dried

**12.4.3** Both the inner tank and the annular space shall be purged to a final oxygen level of 8 percent or less by volume, and dried so that all standing water is removed.

**12.4.4** The inner tank shall be purged first, followed by the annular space.

**12.4.5** When all samples from all sample points display an oxygen content of 8 percent or less, the tank shall be sealed and the flow of nitrogen shall be controlled to maintain a positive pressure.

**12.4.6** Purging shall be considered completed if, 12 hours after the tank is sealed, all samples indicate less than 8.8 percent of oxygen and dew point temperatures at or below the prescribed levels.

**12.4.7** If the entire purging operation is to be accomplished with warm nitrogen, advanced preparations shall be made to begin cool-down after the oxygen and dew point target values are reached. If cool-down of the tank cannot begin, the tank shall be maintained in a purged state until cool-down can begin.

**R12.4—Purging into service**

**R12.4.2** For purging guidelines, refer to Legatos and Marchaj (1994), AGA (1992), Closner et al. (1976), Crawford et al. (1985), Tarakada et al. (1981), Venendaal (1979), and BS EN14620.

**R12.4.3** Prolonged and excessive drying should be avoided, as residual moisture enhances compressive and tensile strength.

**R12.4.4** Regardless of the type of the inner container (metal or concrete), the greatest source of free moisture is the insulation.

**R12.4.5** Legatos and Marchaj (1994) recommend that the dew point temperature be maintained at the lower of the following two values:

- a) Below the dry bulb temperature inside the tank
- b) 14°F inside the inner tank, and 50°F in the annular space and under the floor.

**CODE**

**12.4.8** Alternatively, purging into service shall be permitted to be accomplished by a combination of warm nitrogen gas followed by liquid nitrogen vapor as a prelude to cool-down.

**12.5—Cool-down**

The provisions of this section shall apply when the primary container is concrete.

**12.5.1** A complete cool-down procedure shall be prepared and approved in advance of the cool-down operations to include:

- a) The assignment and duties of operation and supervisory personnel
- b) Type and source purging gas supply and refrigerated liquefied gas (RLG) supply
- c) Identification of piping connections
- d) Preparation and approval of equipment and instrumentation, including the stepwise position (open/closed) of all valves required to isolate and cool down the tank
- e) Cool-down abort procedures during initial filling, and procedures in the event of a long time interval between end of purging and commencement of cool-down
- f) Limits on the temperature parameters for cool-down rates of tank components

**12.5.2** Cool-down operations shall begin after the oxygen and dew point target values have been reached by purging.

**12.5.3** In the period between the end of purging and the start of cool-down, the tank shall be kept at a positive pressure.

**12.5.4** An adequate supply of pressurizing gas shall be available for maintaining proper tank pressure at all times during cool-down.

**COMMENTARY**

**R12.4.8** If purging is to be accomplished by a combination of warm and cold gas, the following procedure may be considered: introduce warm nitrogen vapor until the dew point is lowered to 32°F inside the inner tank, and 50°F in the annular space, then switch to liquid nitrogen through the cool-down ring. The rate of cooling during this stage should follow the criteria for cool-down so as to avoid excessive temperature gradients in the concrete inner wall. The nitrogen cooling is continued until the target oxygen level is reached.

**R12.5—Cool-down**

Provisions also apply, however, to tanks where the inner container is metal, except cool-down rates stated in R12.5.4 and R12.5.7 to R12.5.9 are tank-specific and should reference the contract documents.

**R12.5.2** When possible, cool-down operations should begin immediately after the oxygen and dew point target values have been reached by purging. In certain instances, however, such as in a case of the cool-down abort listed in 12.5.1, Item (e), this might not be possible. Refer to R12.4.2 for additional related information.

**R12.5.3** Before the start of cool-down, the tank should be pressurized to an acceptable internal pressure by adding nitrogen, if necessary. Minimum positive tank pressure not less than 0.7 psi has been previously used. The pressure should be maintained until cool-down spraying starts. Alternative means for maintaining tank pressure should be provided.

**R12.5.4** Pressurizing gas may be required for this purpose at any time, but particularly for:

- a) Maintaining tank pressure in the event of an interruption of the cool-down operation
- b) Protection against development of vacuum in the tank during initial cool-down

Should a continuing decrease in pressure be experienced during initial introduction of RLG, it may become necessary

**CODE**

**COMMENTARY**

**12.5.5** A cool-down spray ring line, when required, shall be located under the suspended deck and equipped with spray nozzles so that cooling down of the tank can be controlled effectively.

**12.5.6** A network of resistance temperature detectors (RTDs), thermocouples, or other temperature-sensing devices shall be provided along the inside (wet) face, and on the outside face of the inner wall, floor subfloor, and annular space to monitor the temperature differences described in 12.5.7 and 12.5.8.

**12.5.7** The cool-down rate, as measured at all of the inner tank temperature sensors, shall be controlled to within prescribed rates (in degrees per hour). The cool-down rate limits shall be as provided in the contract documents.

**12.5.8** The maximum permitted temperature difference between any two temperature sensors shall be maintained within prescribed ranges specified in the contract documents.

**12.5.8.1** The temperature difference limits shall be in accordance with the minimum performance requirements of Chapter 6.

**12.5.9** Pressure and temperature readings shall be recorded, monitored, and controlled continuously to ensure that the limiting thermal gradients, acceptable to the future tank performance defined in Chapter 6, are not exceeded.

**12.5.10** Maximum pressure differential between the annulus and inner tank shall be no more than 5.0 in. (12.5 Mbar) of water with the inner tank always at a higher pressure.

to interrupt the flow of RLG while continuing the supply of pressurizing gas.

**R12.5.5** One of the main objectives of a controlled cool-down for a concrete inner tank is to maintain the temperature gradients across the wall thickness and along the wall height to predetermined levels so as to minimize thermal stresses. A cool-down ring is usually required for liquefied natural gas (LNG). Warmer products do not require cool-down rings.

**R12.5.7** A typical overall cool-down rate is approximately 5.4 to 9.0°F/h or as stated in the contract documents. A typical maximum permitted temperature difference between any two adjacent RTDs (or thermocouples) is 54°F and is 90°F between any nonadjacent RTDs (or thermocouples) except as limited by the recommendations of R12.5.8. Two adjacent RTDs (or thermocouples) are defined as RTDs (or thermocouples): (a) on the same surface located next to each other; or (b) at the same elevation but on opposite faces of the wall.

**R12.5.8** Typical permitted temperature differences are as follows:

- a) Between the inner and outer face of the inner wall: target 25°F; maximum 35°F
- b) Between any two points along a vertical line on the inside face of the wall: maximum 5.5°F/ft but not to exceed 50°F
- c) Between any two points at the same elevation on the inner wall face: maximum 50°F
- d) Between bottom of wall and a point on the floor radially 15 ft away: maximum 35°F

**R12.5.9** For approximately the first 3 hours of the cool-down, pressure and temperature readings should be made as often as possible on a continuous basis. The maximum time interval between readings should not exceed 15 minutes.

If the allowable rate of temperature change is not within the allowable limits, RLG flow should be stopped until appropriate action is taken to ensure that the cool-down rate is under control.

**CODE**

**12.5.11** In LNG tanks, the bottom unloading line shall be opened once LNG has begun to accumulate in the tank.

**12.5.12** In LNG tanks, the cool-down shall be considered complete when the warmest point on the inside face of the wall is at least  $-250^{\circ}\text{F}$  and the thermal gradients are within the specified limits.

**12.6—Settlement and movement monitoring**

The provisions of this section shall apply when the inner (primary) container is concrete or metal.

**12.6.1** The tank design shall provide equipment and instrumentation for the measurement and recording of translational and rotational movement of the inner vessel for use during and after cool-down.

**12.6.2** The tank tilt and differential settlement of the RLG tank and external piping shall be monitored to confirm that settlement is within allowable limits.

**12.6.3** Tank foundations shall be monitored in accordance with Section 10.7 and settlement recorded before, during, and after the hydrotest and first fill of liquefied gases for monitoring of settlement within allowable limits.

**12.6.4** Reference measurements shall be made with appropriate precise instruments to assure that any lateral and vertical movement of the storage tank does not exceed predetermined design tolerances.

**12.6.5** A design professional shall affirm that recorded data for 12.6.1 to 12.6.4 parameters are within allowable limits as provided in the contract documents.

**12.6.6** The tank shall be inspected for cold spots where insulation may have formed air pockets in the vertical side walls.

**COMMENTARY**

**R12.5.11** In LNG tanks, when the average bottom slab temperature is approximately  $-238^{\circ}\text{F}$  and the thermal gradient in the concrete has begun to stabilize, the flow of LNG through the unloading line to bottom of tank may begin. The tank should not be filled from the bottom unloading line yet.

When the average bottom slab temperature is approximately  $-256^{\circ}\text{F}$  and LNG is detected by the tank gauging system, LNG will have begun to accumulate in the tank. At this time, the bottom filling line may be opened and the flow through the cool-down line may be stopped. At this point, before continuing unloading, the emergency shutdown valve should be opened and tested.

**R12.5.12** In LNG tanks, the cool-down can be considered complete if the warmest point on the inside face of the structure is at least  $-250^{\circ}\text{F}$ . If, despite extended spraying, this condition is not reached, the structure can be considered as cooled quasi-complete.

If the cool-down of the structure is complete (so that the warmest point is at least  $-250^{\circ}\text{F}$ ), it can then be filled at specified maximum filling rate unless the rate of filling is limited by geotechnical considerations (for example, need for slow-rate loading of foundations, as may be specified in 12.6). The tank should be initially filled with LNG from the bottom fill line to a height of 10 ft.

If the cool-down of the structure is only quasi-complete (that is, some point will remain warmer than  $-250^{\circ}\text{F}$ ), the rate of bottom filling should be such as to conform to the procedure or practice outlined in R12.5.9. In this case, readings should be taken at intervals not longer than 1 hour.

**CODE**

**COMMENTARY**

**12.7—Liquefied natural gas tank fill methods**

The provisions of this section shall apply when the inner (primary) container is concrete or metal.

**12.7.1** To avoid tank stratification and to promote mixing in the tank, top and bottom fill nozzles for tank filling of refrigerated liquefied gases (RLGs) shall be required.

**12.7.2** Liquid shall not impinge on walls, splash upward to impact the suspended deck, or enter the insulated space above or around the inner tank.

**12.7.3** Liquefied gas entering the tank shall be flashed into vapor.

**12.7.4** The pressure differential between the annulus and inner tank shall be monitored and shall be less than 5.0 in. (12.5 Mbar) of water.

**12.7.5** The flow rates and temperatures shall be monitored to ensure liquefied gas is flashed before striking the bottom of the tank until the tank bottom has reached a temperature of approximately 18°F above the liquefied gas boiling point.

**12.7.6** Tank pumps shall be used for recirculation if stratification or an unsafe density mixture occurs.

**12.7.7** Top and bottom fill lines shall have in-line flow meters for monitoring of tank fill rates to avoid excess flow and high vibration of fill lines and nozzles during fill operations.

**12.8—Decommissioning: purging out of service and warm-up**

The provisions of this section apply when the inner (primary) container is concrete or metal.

**12.8.1 General**—Two methods of tank warm-up shall be permitted:

- a) Natural heat gain through heat exchange through the tank walls and insulation until an equilibrium condition is reached
- b) Accelerated heat gain by the use of a warm vapor flow into the primary tank, allowing the possibility of reduced warm-up durations

Section 12.8.1 addresses the second warm-up scenario.

**R12.7—Liquefied natural gas tank fill methods**

**R12.7.1** The choice of top or bottom fill is based on the density of the liquid currently in the tank as compared with the liquid being added. Rollover is a problem regardless of whether the tank is at a producing location or a receiving location, thus providing both top and bottom fill nozzles should be considered in all tanks. Operators of terminal LNG tanks may want to use a bottom fill to introduce product below the surface to minimize boil-off gas production.

The operators may also want to recirculate the tank to reduce stratification and to provide a more uniform product to the transport. Recirculation is hard to achieve without both top and bottom fill nozzles. Tank stratification is not normally a problem for propylene, ammonia and ethylene.

**R12.7.2** Top fill requires a splash plate on the nozzle outlet to provide a distributed discharge of liquid and removal of entrained vapor.

**R12.8—Decommissioning: purging out of service and warm-up**

**R12.8.1** Warm-up of the tank may be necessary due to any of the following circumstances:

- a) As a prelude to purging and reentry, such as during decommissioning the tank at the end of its service life
- b) The tank is emptied (that is, RLG level is below the lower limit) and is scheduled to remain empty for 48 hours or more
- c) The cool-down operation is interrupted indefinitely after the coldest spot in the prestressed concrete wall has reached a temperature of -40°F or lower.

## CODE

## COMMENTARY

**12.8.2** A complete warm-up procedure shall be prepared and approved by the owner in advance of the warm-up operations and shall include:

- a) The assignment and duties of operation and supervisory personnel
- b) Purging-gas quality and source of supply
- c) Identification of piping connections
- d) Equipment and instrumentation, including the step-wise position (open/closed) of all valves required to isolate and warm-up the tank

**12.8.3** Before commencement of warm-up activities, adequate supply of the gasses used during the warm-up procedure shall be present.

The objective of an accelerated (controlled) warm-up is to speed up the warming of the tank by introducing heat, mainly by means of warm vapor. Natural warm-up is achieved by natural heat exchange between the tank interior and its environment. In both the accelerated and natural warm-up, the main requirements for the safety of the tank are:

- a) To maintain the temperature gradients within the allowable limits
- b) To prevent overpressurization of the tank

If the tank is allowed to warm up by natural heat exchange, it is only necessary to monitor the temperature and pressure readings. If the rate of warm-up is so high as to cause excessive temperature gradients, RLG spray may have to be introduced to slow down the process.

**R12.8.2** A complete warm-up procedure should be prepared and approved in advance of the warm up operations, and should include:

- a) Provisions for continuously maintaining proper operation pressures within the tank while the tank is sealed
- b) Isolation of the tank from all combustible gas lines before the introduction of air
- c) Special provisions for the removal of product vapors from the insulation under the floor, in the annular space, and on the suspended deck. For this purpose, the procedures should include provisions for cycling gas flow through the purge piping (alternating between supply and withdrawal)—especially through the purge lines terminating in the floor and the annular space
- d) In the case of a nitrogen purge intended to eliminate product gas before the introduction of air, the following should be specified:
  - i. Maximum product content limits to be met before the introduction of air
  - ii. A wait and resample procedure

In the case of preparation for human entry, safety limits on gas content and temperatures, and safety procedures for entry should be established.

**R12.8.3** Before commencement of warm-up activities, adequate supply of the following gases should be available:

- a) Refrigerated liquefied gas (RLG)—RLG should be available for possible spraying from the cool-down ring if the warm-up must be slowed down because of excessive temperature gradients.
- b) Product gas—product vapor should be controlled so that the necessary amount of heated product vapor will be available for the tank warm-up. As an alternative, nitrogen vapor may also be used for this purpose only if the accelerated warm-up procedure is being used.
- c) Nitrogen—nitrogen vapor may be supplied in the event that methane vapor is not available for any reason to complete the warm-up procedure. Nitrogen can be used for this purpose only if the accelerated warm-up procedure is being used.



## CODE

**12.8.4** Liquid RLG levels in the tank shall be reduced to the minimum possible level using tank pumps.

**12.8.5** The exiting gas temperature and inner tank temperature sensors shall be monitored and recorded to avoid developing too high of a warming rate or temperature differentials that cause undue stress of the tank floor.

**12.8.6** If hydrocarbon gas was used for warm-up, nitrogen shall be required for removal of flammable gas before air being introduced.

**12.8.7** The following variables shall be monitored for the purpose of controlling the purging operation:

- a) Nitrogen flow
- b) Internal tank pressure
- c) Oxygen content
- d) Dew point temperature
- e) Temperature of nitrogen purging gas

**12.8.8** The elevation of insulation in annulus shall be verified after cool-down and refilled to the proper elevation before placing the tank into service.

### 12.9—Recordkeeping

The provisions of 12.9 shall apply whether the inner (primary) container is concrete or metal.

**12.9.1** For the service life of each component concerned, each owner shall retain appropriate records of the commissioning activities as follows:

- a) Specifications, procedures, and drawings prepared for the RLG tank commissioning and decommissioning activity
- b) Results of tests, inspections, and the quality assurance review program

### 12.10—Nameplate

Permanent nameplates shall be provided for each primary and secondary liquid-containing tank in a location where they are readily visible. Unless otherwise specified, nameplates shall be attached to the wall of the outer tank. Information on nameplates shall comply with requirements of the code or standard to which the tank was designed and constructed. Nameplates for tanks designed and constructed in accordance with ACI 376 shall comply with 12.10.1 and 12.10.2.

## COMMENTARY

**R12.8.4** If pumping is not adequate to reduce the liquid level, the under-tank heating system may be used to warm the base slab and allow boil-off of the remaining RLG.

**R12.8.5** The tank should be monitored during warm-up to ensure that the thermal gradients in the tank comply with allowable limits defined in R12.5.7 and R12.5.8. If the thermal gradients are exceeded during accelerated warm-up, the flow of warm vapor should cease to allow the thermal gradients to return to acceptable levels. If further reduction of thermal gradients is necessary, RLG should be sprayed into the tank to continue to reduce thermal gradients to an acceptable level. Once the thermal gradients have been controlled, the warm-up operation may restart while continuing to monitor and maintain the maximum temperature gradients as previously indicated.

**R12.8.8** Compaction of perlite in the annular space during warm-up and settlement of perlite during cool-down is a common occurrence with RLG tanks.

### R12.10—Nameplate

For tanks with the primary tank designed in accordance with API 620, refer to API 620 for the nameplate requirements. The secondary containment nameplate should be provided as defined in this section. For double- or full-containment storage tanks with the primary and secondary containments designed and constructed in accordance with this code require separate nameplates for each liquid container.

**CODE****COMMENTARY**

**12.10.1** The information on the nameplate shall be defined using 5/32 in. letters and numerals. Each name plate shall indicate the following information:

- a) ACI 376 and revision year
- b) Type of container: primary liquid container or secondary liquid container
- c) Year completed
- d) Nominal diameter (units of feet and inches)
- e) Nominal height (units of feet and inches)
- f) Design liquid level (units of feet and inches)
- g) Design liquid level (units of feet and inches)
- h) Design specific gravity of liquid
- i) Maximum water level for hydrostatic test (units of feet and inches)
- j) Design vapor space gas pressure above the liquid level (units of lb/in<sup>2</sup>)
- k) Minimum design product temperature as specified by the project documents
- l) Purchaser's tank number
- m) The name of the manufacturer with identification number to identify the specific tank

**12.10.2** The nameplate shall be fabricated from corrosion-resistant metal. Each nameplate shall be attached to a galvanized or noncorrosive plate embedded in the concrete wall.

**R12.10.1** The units of measure may be modified or additional pertinent information may be added at the request of the owner.

CODE

COMMENTARY

APPENDIX A—TANK CONFIGURATIONS, DETAILS, AND EXAMPLES

RA.1—Tank configurations

Figures RA.1a through RA.1e are examples of single-, double-, and full-containment concepts covered by this code (adapted from BS EN 1473).

RA.2—Full-containment tanks: typical details

Figures RA.2a and RA.2b illustrate typical details for full containment LNG tanks with steel and concrete primary containers.

RA.3—Examples of base joint details

Figures RA.3a through RA.3c illustrate details of various base joint details (adapted from BS 7777-2), and Fig. RA.3d illustrates prestressing details for internal tendon systems.

Table RA.3 lists advantages and disadvantages of the base details commonly used in practice. The secondary container of a full containment typically uses a fixed base connection in conjunction with a thermal corner protection (TCP) that mitigates the effects of self-straining forces (Fig. RA.2a(c)).

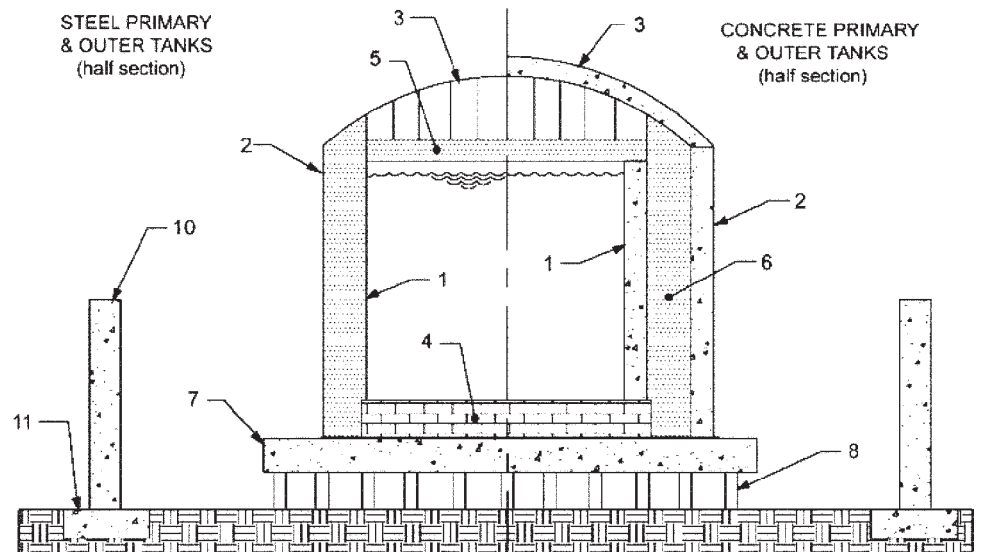

LEGEND

- |   |  |
|---|--|
| 1 Primary container (steel or prestressed concrete)                                       | 6 Loose fill insulation                                  |
| 2 Outer tank shell (steel or prestressed concrete) - vapor barrier & insulation container | 7 Foundation slab  |
| 3 Tank roof (steel or concrete)   | 8 Piles  |
| 4 Bottom rigid insulation   | 9 Foundation heating system                              |
| 5 Suspended ceiling insulation  | 10 Bund wall (dike) - prestressed or reinforced concrete |
|   | 11 Bund wall footing                                     |

Fig. RA.1a(a)—Single-containment tank system with elevated slab and no slab heating.

CODE

COMMENTARY

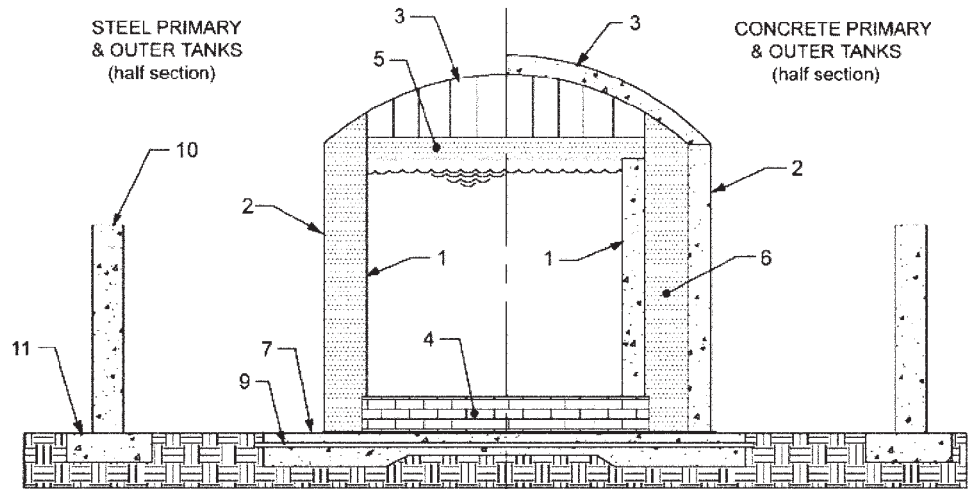

LEGEND

- |   |  |
|---|--|
| 1 Primary container (steel or prestressed concrete)                                       | 6 Loose fill insulation                                  |
| 2 Outer tank shell (steel or prestressed concrete) - vapor barrier & insulation container | 7 Foundation slab  |
| 3 Tank roof (steel or concrete)   | 8 Piles  |
| 4 Bottom rigid insulation   | 9 Foundation heating system                              |
| 5 Suspended ceiling insulation  | 10 Bund wall (dike) - prestressed or reinforced concrete |
|   | 11 Bund wall footing                                     |

Fig. RA.1a(b)—Single-containment tank system with heated slab.

CODE

COMMENTARY

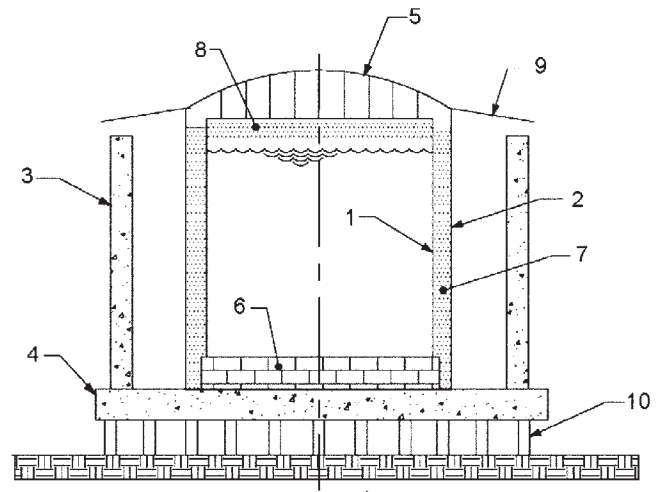

LEGEND

- |  |                                |
|--|--------------------------------|
| 1 Primary container (steel)                  | 7 Loose fill insulation        |
| 2 Outer steel shell (vapor barrier)          | 8 Suspended ceiling insulation |
| 3 Secondary container (prestressed concrete) | 9 Rain shield                  |
| 4 Foundation slab                            | 10 Piles                       |
| 5 Steel roof                                 | 11 Foundation heating cables   |
| 6 Bottom rigid insulation                    |                                |

Fig. RA.1b(a)—Double-containment tank system with elevated slab and no slab heating.

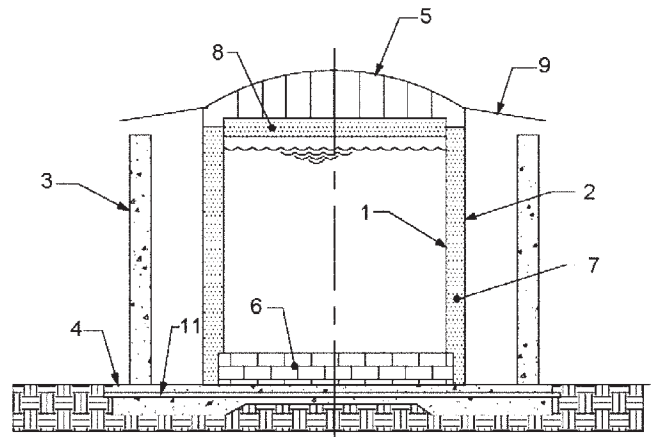

LEGEND

- |  |                                |
|--|--------------------------------|
| 1 Primary container (steel)                  | 7 Loose fill insulation        |
| 2 Outer steel shell (vapor barrier)          | 8 Suspended ceiling insulation |
| 3 Secondary container (prestressed concrete) | 9 Rain shield                  |
| 4 Foundation slab                            | 10 Piles                       |
| 5 Steel roof                                 | 11 Foundation heating cables   |
| 6 Bottom rigid insulation                    |                                |

Fig. RA.1b(b)—Double-containment tank system with heated slab.

CODE

COMMENTARY

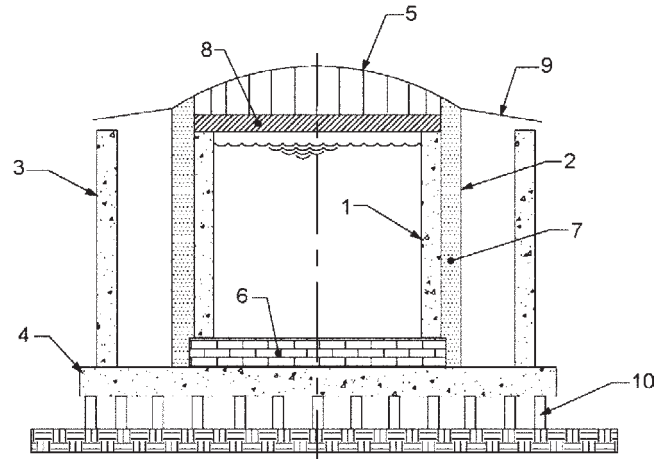

LEGEND

- |  |                                |
|--|--------------------------------|
| 1 Primary container (prestressed concrete)   | 7 Loose fill insulation        |
| 2 Outer steel shell (vapor barrier)          | 8 Suspended ceiling insulation |
| 3 Secondary container (prestressed concrete) | 9 Rain shield                  |
| 4 Foundation slab                            | 10 Piles                       |
| 5 Steel roof                                 | 11 Foundation heating cables   |
| 6 Bottom rigid insulation                    |                                |

Fig. RA.1c(a)—Double-containment concrete tank system with elevated slab and no slab heating.

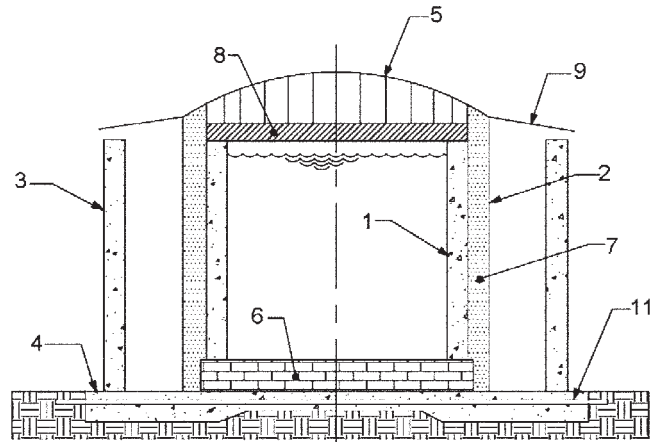

LEGEND

- |  |                                |
|--|--------------------------------|
| 1 Primary container (prestressed concrete)   | 7 Loose fill insulation        |
| 2 Outer steel shell (vapor barrier)          | 8 Suspended ceiling insulation |
| 3 Secondary container (prestressed concrete) | 9 Rain shield                  |
| 4 Foundation slab                            | 10 Piles                       |
| 5 Steel roof                                 | 11 Foundation heating cables   |
| 6 Bottom rigid insulation                    |                                |

Fig. RA.1c(b)—Double-containment concrete tank system with heated slab.

CODE

COMMENTARY

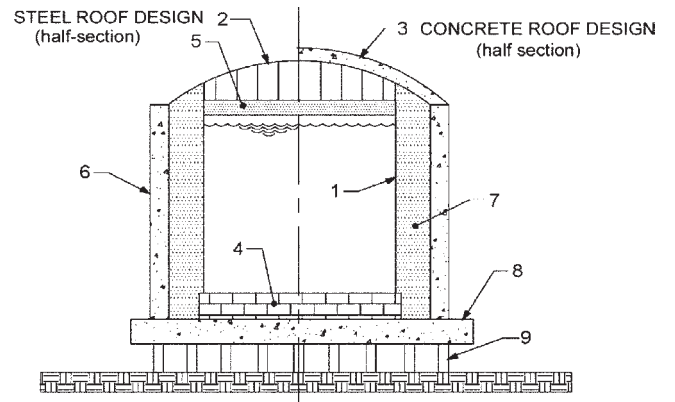

- LEGEND
- |  |  |
|--|--|
| 1 Primary container (prestressed concrete) | 6 Secondary container and vapor barrier (prestressed concrete) |
| 2 Steel roof                               | 7 Loose fill insulation  |
| 3 Concrete roof                            | 8 Foundation slab  |
| 4 Bottom rigid insulation                  | 9 Piles  |
| 5 Suspended ceiling insulation             | 10 Foundation heating system                                   |

Fig. RA.1d(a)—Full-containment tank system with elevated slab and no slab heating.

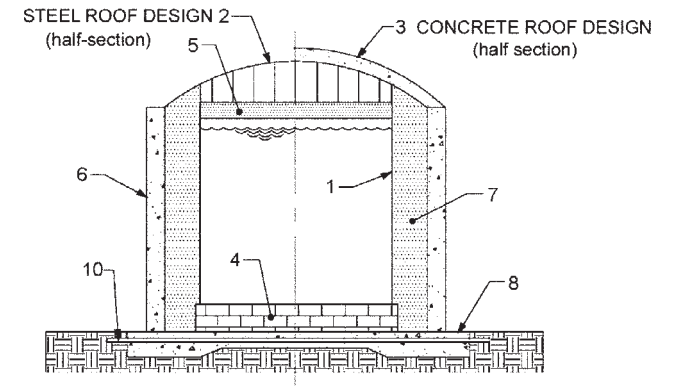

- LEGEND
- |  |  |
|--|--|
| 1 Primary container (prestressed concrete) | 6 Secondary container and vapor barrier (prestressed concrete) |
| 2 Steel roof                               | 7 Loose fill insulation  |
| 3 Concrete roof                            | 8 Foundation slab  |
| 4 Bottom rigid insulation                  | 9 Piles  |
| 5 Suspended ceiling insulation             | 10 Foundation heating system                                   |

Fig. RA.1d(b)—Full-containment tank system with heated slab.

CODE

COMMENTARY

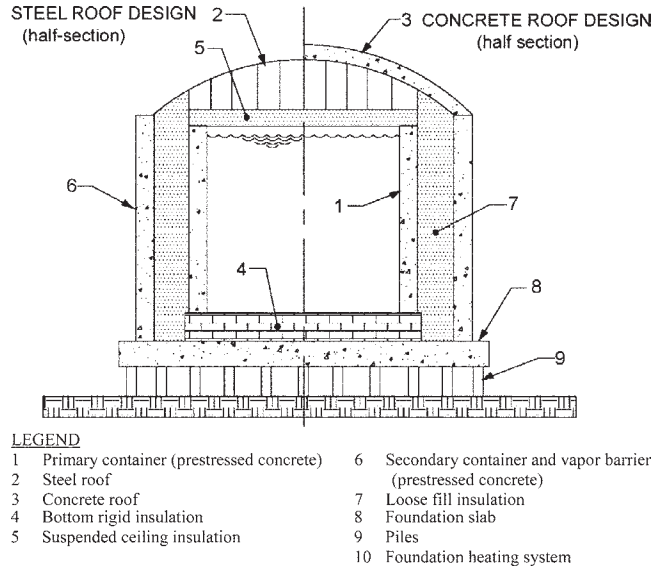

Fig. RA.1e(a)—Full-containment concrete tank system with elevated slab and no slab heating.

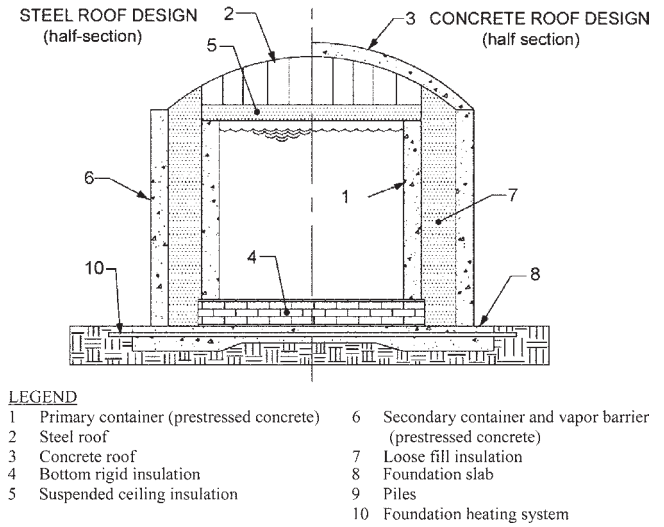

Fig. RA.1e(b)—Full-containment concrete tank system with heated slab.



CODE

COMMENTARY

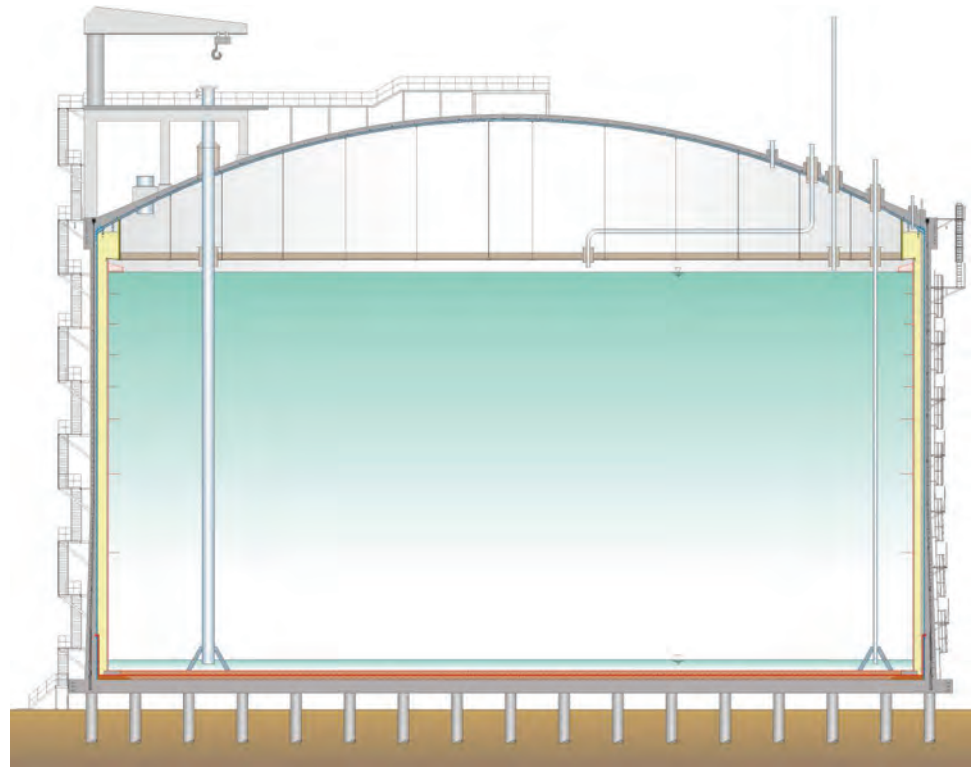

Fig. RA.2a(a)—Example of fixed-base full containment for LNG (internally prestressed concrete secondary outer tank and 9-Ni steel primary tank).

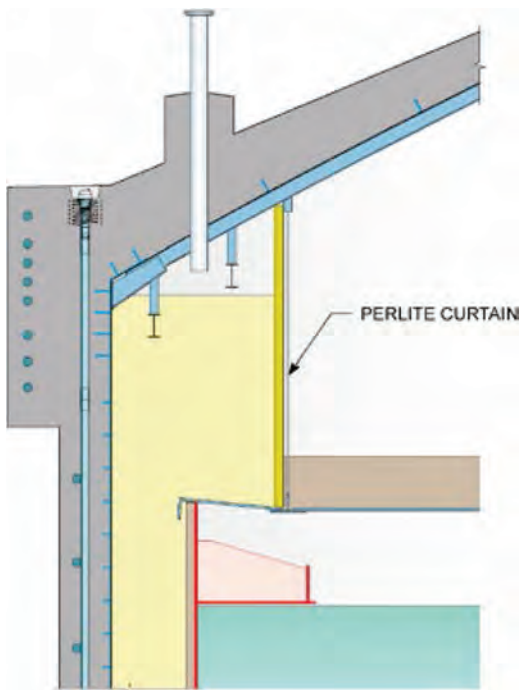

Fig. RA.2a(b)—Example of fixed-base full containment for LNG—detail at roof.

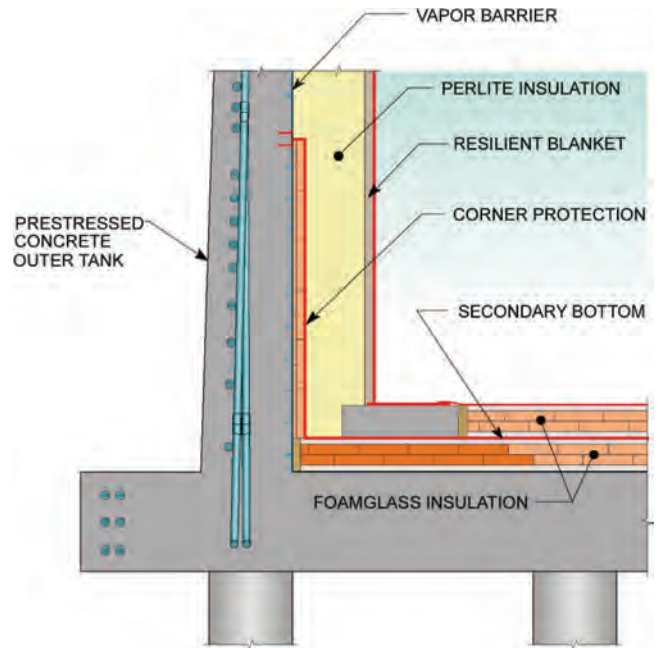
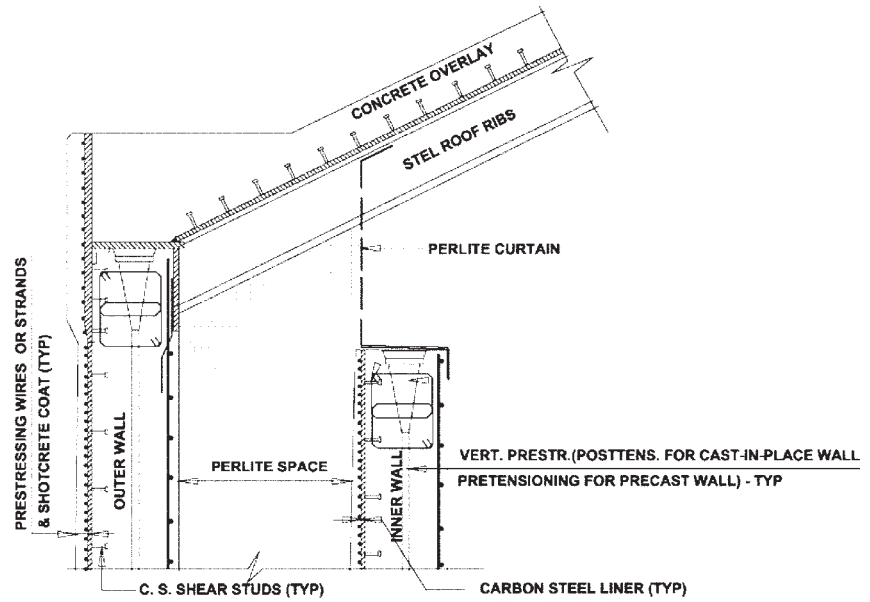

Fig. RA.2a(c)—Example of fixed-base full containment for LNG—detail at foundation.

CODE

COMMENTARY



(a) Detail at roof

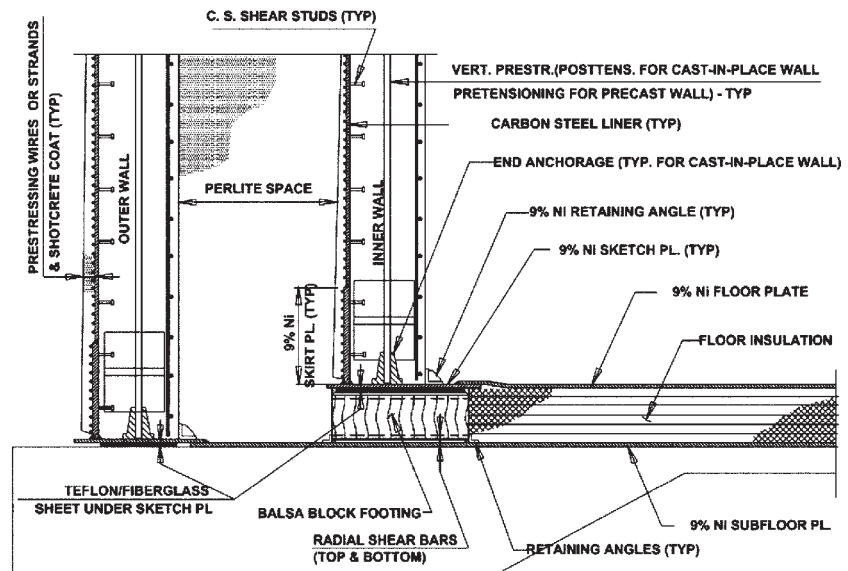

(b) Detail at foundation

Fig. RA.2b—Example of externally prestressed full containment for LNG (concrete primary and secondary tanks).

CODE

COMMENTARY

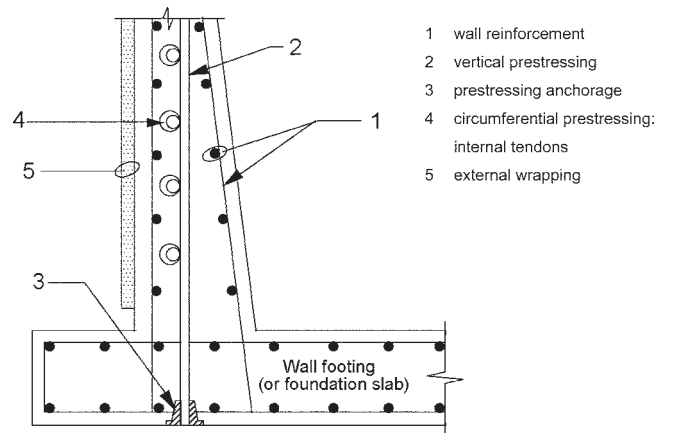

Fig. RA.3a(a)—Example of fixed joint details (monolithic construction).

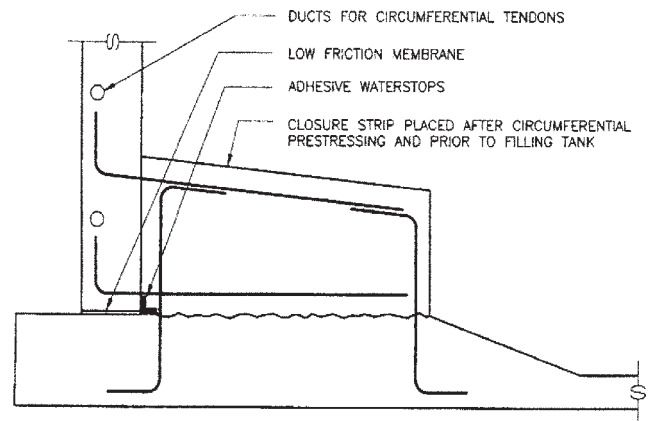

Fig. RA.3a(b)—Example of fixed wall-to-base joint details (closure strip).

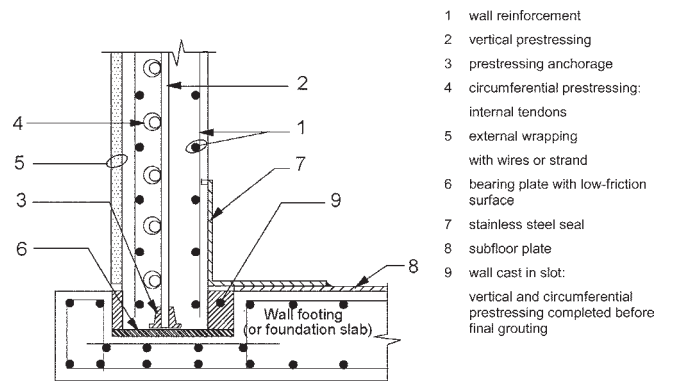

Fig. RA.3b—Example of pinned wall-to-base joint details.

CODE

COMMENTARY

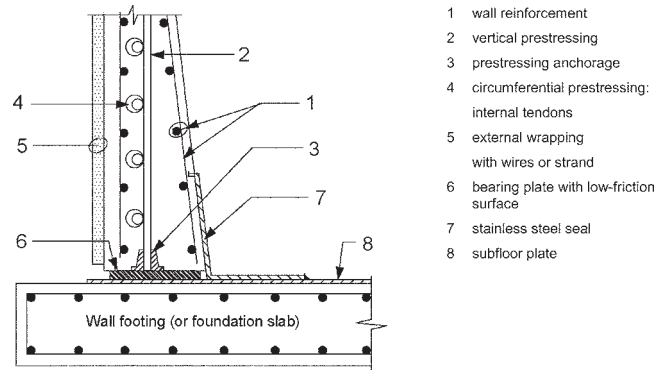
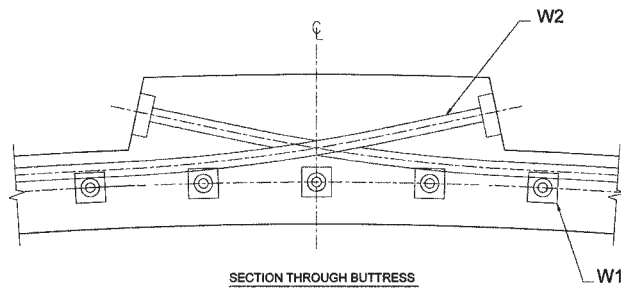
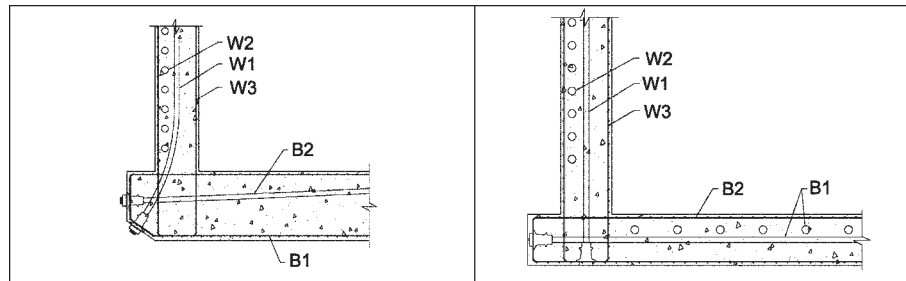

Fig. RA.3c—Example of sliding wall-to-base joint details.



- W1 Vertical wall prestressing
- W2 Horizontal wall prestressing
- W3 Wall reinforcement
- B1 Base slab prestressing
- B2 Base slab reinforcement

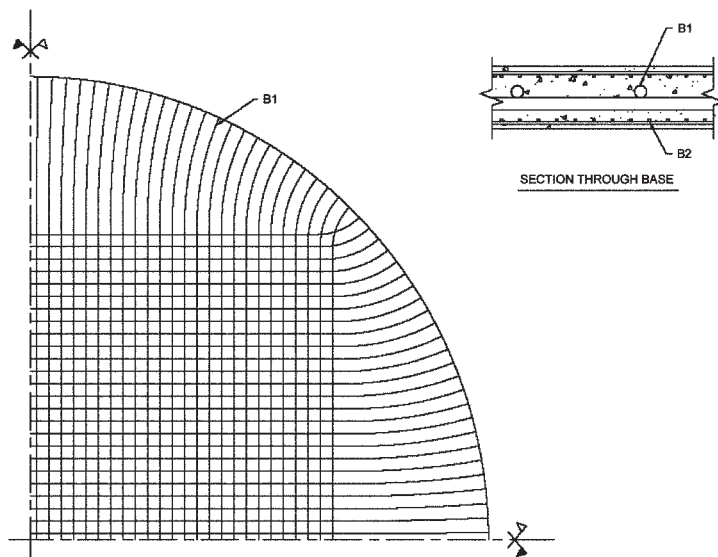

Fig. RA.3d—Examples of tendon prestressing details.

**CODE**

**COMMENTARY**

**Table RA.3—Summary of advantages and disadvantages of joints in wall-to-base junction**

System	Advantages	Disadvantages
Fixed joint	<ul style="list-style-type: none"> <li>• Robust form of construction</li> <li>• Full vertical prestressing in bottom of wall</li> </ul>	<ul style="list-style-type: none"> <li>• Larger moments and shears</li> <li>• Maximum moment occurs at the joint</li> </ul>
Pinned joint	<ul style="list-style-type: none"> <li>• Prestress is predicted with good reliability</li> <li>• Maximum moment occurs in wall away from the joints, at level where end effects from vertical tendons are largely smoothed out</li> </ul>	<ul style="list-style-type: none"> <li>• Dependent on adequacy of joint seal unless the joint is made impermeable with the use of a liquid- and vapor-tight metal liner</li> <li>• Subsequent secondary stresses are less reliable</li> <li>• Large shears and fairly large moments</li> </ul>
Sliding joint	<ul style="list-style-type: none"> <li>• Prestressing and primary stresses are predicted with a high degree of reliability</li> <li>• Secondary stresses are relatively small</li> </ul>	<ul style="list-style-type: none"> <li>• Dependent on adequacy of joint seal unless the joint is made impermeable with the use of a liquid- and vapor-tight metal liner</li> <li>• Some uncertainty over degree of sliding obtained</li> </ul>

**CODE****COMMENTARY****APPENDIX B—OFFSHORE CONCRETE  
TERMINALS****B.1—Scope**

This appendix focuses on gravity-base structures (GBS), and floating concrete offshore liquid natural gas (LNG) and other refrigerated liquefied gas (RLG) (LNG/RLG) terminals. Offshore LNG/RLG terminals can be fixed (including GBS and pile-founded) or floating structures (including floating storage units [FSU], floating storage and regasification units [FSRU], and buoys for custom carrier vessels), and can be built from either concrete or steel.

This appendix provides guidance on the design criteria and requirements for the following considerations for offshore LNG/RLG structures:

- a) The design philosophy of LNG/RLG containment system
- b) Environmental conditions
- c) Significant topside loads
- d) Accident scenario
- e) Load conditions covering dry dock construction, inshore and offshore towing, and offshore installation

In addition, this appendix also addresses the following:

- a) Additional requirements for concrete materials in marine environment
- b) Some aspects of the state-of-the-art technology in the design of the offshore concrete GBS or floating hull

**B.2—General**

Wherever applicable, design criteria and requirements as specified in the other chapters of this code shall be used to design the concrete GBS or floating hull.

**RB.1—Scope**

This appendix gives guidance to individuals charged with design and construction of offshore LNG structures and offshore RLG structures. The requirements in this appendix are intended to supplement the general requirements for reinforced concrete and prestressed concrete design and construction given in ACI 318, ACI 350, ACI 301, ACI 357R, other national and international codes, and this code. Although the focus is principally on LNG structures (Berner and Gerwick 2001; Jiang et al. 2004a,b; API 2000; DNV-OS-C503), the same criteria, design and construction requirements, transportation and installation requirements, and commissioning and decommissioning requirements also apply to offshore RLG structures.

Offshore LNG/RLG terminals can be categorized as:

- a) LNG/RLG exporting terminals
- b) LNG/RLG receiving terminals

LNG/RLG exporting terminals supply LNG/RLG to carrier ships for shipment. LNG/RLG receiving terminals receive LNG/RLG from the LNG/RLG carrier ships and supply gas to onshore markets.

Frequently, the concrete GBS or floating hull consists of double-hull and double-bottom structures for ballasting or buoyancy during towing. The ballast compartments of the double hull can also be used for balancing the hydraulic pressure exerted on the exterior hull.

The inner walls of the concrete GBS, or floating, hull will act as an outer containment structure and may also be designed as the secondary container, depending on the design philosophy of the primary inner LNG/RLG containment system.

Other potential offshore concrete LNG/RLG terminal configurations include:

- a) Cylindrical LNG/RLG tanks mounted on a fixed or floating concrete barge
- b) Cylindrical LNG/RLG tanks mounted on a pile-supported platform
- c) Single-hulled vessels

**RB.2—General**

The design of the concrete GBS or floating hull for offshore LNG/RLG terminals will be different than the design of the concrete structures for onshore RLG containments due to the considerations given in B.1 of this code. The design philosophy concerning a primary containment tank failure or leakage of the LNG/RLG containment system for an offshore LNG/RLG terminal has been influenced by both onshore codes and LNG/RLG ship rules. The onshore codes require that secondary containment systems be capable of containing the full liquid contents of the primary tank with either a bund, or double/full containment system such as a prestressed concrete cylindrical wall. In contrast, LNG/RLG ship rules accept a leak-before-failure philosophy for some

**CODE**

**COMMENTARY**

**B.3—Loads and load combinations**

**B.3.1 Environmental loads**—Where applicable, the design shall consider the following environmental loads:

- a) Waves
- b) Wind
- c) Currents
- d) Tides and storm surges
- e) Air and sea temperatures
- f) Ice and snow
- g) Marine growth
- h) Sea ice
- i) Seismicity

Other phenomena, such as tsunamis, abnormal composition of air and water, air humidity, salinity, ice drift, and icebergs shall also be considered depending on the specific installation site.

**B.3.1.1 Wave loads**

**B.3.1.1.1** Wave loads shall be considered based on the following:

- a) Orientation of the terminal and any berthed vessels
- b) Operating environmental condition
- c) Design environmental condition

**B.3.1.1.2** The return period of the design environmental condition wave shall be not less than 100 years, unless adequacy can be proved based on sound engineering justifications.

**B.3.1.1.3** If global dynamic amplification responses of the GBS (including foundation interactions) or floating hull responses to the wave-excitation forces are significant, then the hydrodynamic (wave) loads (considering the wave spectra) as determined from measured data or numerical projections appropriate for the terminal site shall be used.

**B.3.1.1.4** Wave loads shall be combined with the effect of current, tide, and storm surge considering joint probabilities of occurrence. Wave loads shall be considered in multiple directions.

**B.3.1.1.5** Wave excitation forces and currents on the concrete GBS or floating hull shall be calculated in accordance with recognized methods, including the following:

types of tanks. Whether or not the inner wall of concrete hulls should be designed as a secondary containment based on a leak-before-failure philosophy depends on the following:

- a) The logistic, degree, and mechanism of the integration between the containment system and the concrete hull
- b) The approval from regulatory agencies and owner's requirements

**RB.3—Loads and load combinations**

**RB.3.1** Marine growth increases wave forces (by increasing member diameter and surface roughness) and mass of the structure, and should be considered in design. Consideration should also be given to the types of fouling likely to occur and their possible effects on corrosion protection coatings.

Any strong low-pressure system in a coastal area may produce a storm surge. Contrary to astronomical tides, storm surges are caused by pressure difference, also referred to as pressure difference tide, wind, or both, that pushes the water ahead of a storm, also referred to as wind tide. Storm surge affects water depth and wave crest.

**RB.3.1.1.1** The operating environmental condition waves occur frequently during the life of an offshore LNG/RLG terminal. The design environmental condition waves occur rarely during the life of an offshore LNG/RLG terminal.

Deterministic static wave loads can be used in the primary design of the concrete GBS or floating hull, provided that the design wave height and associated wave period can cover the sea states adequately.

**RB.3.1.1.5** A combination of both model tests and numerical calculations may be necessary to compute the wave

## CODE

- a) Wave kinematics theories
- b) Diffraction theory
- c) Morison's Equation
- d) Model test

**B.3.1.1.6** To deal with wave loads on large-volume bodies, such as the GBS or floating hulls, full recognition shall be given to the limitations of the standard analysis methods given in B.3.1.1.5(a) through (d).

**B.3.1.2** *Seismic loads*

**B.3.1.2.1** Seismic loads shall be considered in the design of concrete GBS offshore LNG/RLG terminals based on the following:

- a) OBE, per NFPA 59A
- b) SSE, per NFPA 59A

The following return periods shall be considered in the design:

- a) OBE: 475-year return period
- b) SSE: 4975-year return period

**B.3.1.2.2** The following shall also be acceptable for the design of the platform only (while the primary containment must still be designed to NFPA 59A requirements):

- a) Strength level earthquake (SLE)
- b) Ductility level earthquake (DLE)

The DLE shall be used to evaluate the risk of structural collapse.

The following return periods shall be met as the minimum requirements for design:

- a) Strength level: not less than a 200-year return period
- b) Ductility level: a few hundred years to a few thousand years return period, depending on the structural design

**B.3.1.2.3** The consideration of either the OBE/SSE or SLE/DLE approach shall be subject to the approval from the National Regulatory, owner's requirement, and classification society. If the platform is designed using the SLE/DLE approach, then the primary containment shall be checked for both structural integrity and leak tightness while supported by a damaged or deformed platform by SLE/DLE events.

## COMMENTARY

loads due to the highly nonlinear effects created by the large body near the still water level.

**RB.3.1.2** The operating basis earthquake (OBE) is a probable earthquake to which the facility may be subjected during its design life. All elements of the facility are designed to withstand this event in accordance with conventional engineering procedures and criteria, and therefore, the facility will remain in operation.

The safe shutdown earthquake (SSE) is a rare earthquake of extreme magnitude for the facility location. The facility is designed to contain the LNG/RLG and prevent catastrophic failure of critical facilities under this contingency event. Plastic behavior and significant finite movements and deformations not usually considered in conventional engineering procedure are possible. The facility is not required to remain operational following the SSE event. Following such an event, the facility is to be inspected and repaired as necessary.

**RB.3.1.2.2** Consider the traditional design practice of offshore industry (Lloyd's 2004; ACI 357R). Alternatively, the SLE and the DLE are also acceptable for the design of the platform.

The SLE has a reasonable likelihood of not being exceeded during the life of the terminal, and will induce only limited damage to the structure. The DLE has a reasonable likelihood of a rare intensity-level earthquake occurring.



**CODE**

**COMMENTARY**

**B.3.2** *Soil loads*—In addition to the soil and geotechnical design criteria as specified in Chapter 8, the following sources of soil loading shall also be considered:

- a) Soil dredging and backfill
- b) Prevention of foundation scouring
- c) Submarine slides

**B.3.3** *Functional loads*—The design of the GBS or floating hull shall consider functional loads, including permanent and variable loads.

**B.3.3.1** *Permanent loads*—The functional permanent loads shall include the following:

- a) Self-weight of the structure
- b) Weight of permanent ballast
- c) Weight of permanently topside facilities including riser
- d) External hydrostatic pressure up to the mean water level
- e) Temporary or permanent mooring loads for floating structures
- f) Deformation loads

Deformation loads shall conform to Chapter 5 and shall also include the following:

- a) Prestressing effects
- b) Thermal effects
- c) Creep and shrinkage effects
- d) Differential settlement of foundation components

**B.3.3.2** *Live loads*

The functional live loads shall include the following:

- a) Personnel
- b) Removable modules or topside facilities during the operation phase
- c) Uniformly distributed loads or concentrate loads in storage area
- d) Liquid content and pressure in storage compartments (for ballasting), ordinary boat impact, fendering, and vessel mooring to the structure
- e) Sloshing loads in both floating and fixed structures
- f) Loads occurring during construction, inshore and offshore towing, and offshore installation

**B.3.4** *Accidental loads*—The design of the concrete GBS or floating hull as an outer containment structure shall consider the following accident scenarios:

- a) Boat/vessel impact from LNG/RLG ship, supply boat, and tugs
- b) Dropped objects from loading/offloading arm and crane
- c) Fires, including pool fire, jet fire, and fireball
- d) Explosion, including the event occurring simultaneously with fires
- e) Unintended loss of pressure difference due to ballasting or buoyancy
- f) Failure of any mooring system
- g) Thermal shock due to LNG/RLG spilling or overflow

**RB.3.3** The functional loads, including permanent and variable loads, may vary depending on the type of structure, its intended use, and the environment in which the structure will be placed.

**RB.3.4** The outer walls and roof of a concrete GBS or floating hull that function as an outer containment structure will be exposed to a variety of potential accident scenarios. The effects of these accidents on the structure should be considered in the design.

## CODE

## COMMENTARY

**B.3.4.1** The thermal shock loads due to LNG/RLG spilling or overflow shall be considered if the inner wall of the concrete GBS or floating hull is designed as a secondary containment and is required to be able to contain the full liquid contents of the tank with a bund or a double/full containment system. The thermal shock loads shall be determined in accordance with the following:

- a) Chapters 6 and 7 of this code
- b) The thermal gradient between the inner face and outer face of the inner concrete wall calculated based on finite element thermal analysis

The more stringent of B.3.4.1(a) and B.3.4.1(b) shall be used in the design.

**B.3.4.2** The probability of exceedance of the accident scenarios shall be determined based on risk and reliability analysis. The accidental loads corresponding to the probability of exceedance of  $10^{-4}$  shall be targeted. The probability of exceedance of  $10^{-5}$  and  $10^{-3}$  shall be targeted as high consequence and low consequence to life, environment, and navigation.

**B.3.4.3** When historical data are not available on accident scenarios, experts' opinions gained from successful and unsuccessful experiences shall be regarded as valuable resources.

#### B.4—Concrete and reinforcement materials

**B.4.1** *General requirements*—Concrete and reinforcement materials shall be in accordance with Chapter 3 of this code and ACI 318.

**B.4.2** *Marine exposure*—To consider the marine environment and thermal effects in addition to the requirements given in the design codes in B.4.1, the concrete and reinforcement materials shall be subject to the additional requirements cited in the following portions of this section, whichever are more stringent.

Due to the effect of marine environment, the maximum water-cementitious material ratio ( $w/cm$ ), minimum cementitious content, and minimum compressive strength of the concrete specified for different exposure zones shall be in compliance with the following:

Zone	$w/cm$ by weight	Minimum quantity of cementitious material, lb/yd <sup>3</sup>	Minimum compressive 28-day strength $f'_c$ , psi
Submerged zone	0.45	575	6500
Splash or atmospheric zone	0.4	675	7200
Interior zone	0.45	575	6500

Note: The value of the minimum quantity of cementitious material is for 0.75 in. maximum size of aggregate. For larger-sized aggregate, the value are reduced if required. The 28-day strength ( $f'_c$ ) test is based on 6 x 12 in. cylinder test samples.

**B.4.3** *Concrete strength*—Concrete compressive strength  $f'_c$  shall be determined based on 28-day cylinder test results.

#### RB.4—Concrete and reinforcement materials

**RB.4.1** ACI 357R contains some guidelines on the concrete and reinforcing materials to be used in offshore concrete structures.

## CODE

If design loads act on the structure earlier than 28 days after casting, then the compressive strength shall be determined for the actual age of loading. The strength gain as the concrete ages shall be deemed acceptable for design, provided that the following are considered:

- a) Reduction in strength due to sustained loads and thermal cracking
- b) Reduced strength that results from low-cycle fatigue and cyclic wetting and drying
- c) Unusually aggressive environments that lead to accelerated concrete deterioration

**B.4.4 Reinforcement/prestressing requirements**—The ductility and toughness requirements of the mild reinforcement and the prestressing tendons shall be in accordance with Chapter 3 of this code.

### B.5—Global and local structural analysis

#### B.5.1 Global analysis

**B.5.1.1** A global analysis based on finite element analysis shall be required to predict the load path, stress and strain status, or both, in the structure, or part thereof, in response to each significant load case.

**B.5.1.2** The global analyses shall be performed in compliance with the criteria and requirements as specified in Chapter 7 of this code and subject to the guidance provided in the following sections of this code.

**B.5.1.3** The global analysis of the GBS shall consider the following soil and geotechnical effects:

- a) Distribution of the soil reaction and soil differential settlement, rocking of the structure on its foundations, or both, including the influence of any adjoining modules or structures
- b) Soil liquefaction
- c) Frost heave
- d) Deviations of soil stiffness and modulus of elasticity

**B.5.1.4** A global structural analysis predicting the structural response of the entire floating hull shall be based on the applicable classification rules for offshore floating structures.

## COMMENTARY

**RB.4.4** The requirements of B.4.4 are particularly important if the inner wall of the concrete GBS or floating hull is designed as a secondary containment and is required to be able to contain the full liquid contents of the tank with a bund or double/full containment system.

### RB.5—Global and local structural analysis

The concrete GBS or floating hull for an offshore LNG/RLG terminal will usually be a complex structure requiring a computer-aided analysis. In addition to the global analysis, a fine mesh finite element analysis may be necessary for some structural regions, such as high-stress-concentration regions, stress- and strain-disturbed regions, and geometry discontinuity regions.

**RB.5.1.1** A global structural analysis predicts the structural response of the entire GBS, including the controlling load cases for each of the following:

- a) Overturning moment
- b) Base shear
- c) Torsional moment in earthquake or extreme impact
- d) Global shell deformation or ovalization forces

**RB.5.1.3** Global seismic analysis of the GBS is very complicated. Dynamic analysis using response spectrum method should not be allowed except for preliminary calculations. The detailed global analysis must include soil-structure interaction effects. GBS base slab and wall flexibility should be modeled.

## CODE

## COMMENTARY

**B.5.1.5** General guidance as to types of analyses shall be adopted for different design conditions as appropriate and are as follows:

- a) Linear, static, or quasi-static analysis shall be accepted for the structural analysis for strength and serviceability limit states under in-place operation, construction, transportation, and installation load cases.
- b) Dynamic effects shall be considered where global response to hydrodynamic/seismic loads is significant.
- c) Frequency domain analyses, time domain analyses, or both, shall be used to predict global responses to hydrodynamic loads and motions, including sloshing of the cargo.
- d) Spectra dynamic or time-history analyses shall normally be required for the seismic analysis of the GBS where the seismic ground motion is significant, including the influence of hydrodynamic added mass and sloshing. Nonlinear effect may be necessary to be considered for the ductility level earthquake.
- e) For OBE/SSE, when responses from the three earthquake components are calculated separately in response spectrum analysis, all possible combinations of the three components— $R_1$ ,  $R_2$ , and  $R_3$ —including variations in sign (plus or minus), shall be evaluated by

$$R = \pm[R_1 \pm 0.4R_2 \pm 0.4R_3]$$

or

$$R = \pm[R_2 \pm 0.4R_3 \pm 0.4R_1]$$

or

$$R = \pm[R_3 \pm 0.4R_1 \pm 0.4R_2]$$

where  $R_1$  and  $R_2$  are the two horizontal components, and  $R_3$  is the vertical component. These components for the OBE/SSE approach are used as scalar values in design computations.

**B.5.1.6** For the SLE/DLE approach, when three-dimensional site-specific ground motion spectra (two orthogonal horizontal directions and one vertical direction) are developed, the actual directional accelerations shall be used in spectral dynamic analysis.

**B.5.1.7** If single-site spectra are applicable, the 100 percent spectra shall be applied to both orthogonal and horizontal directions simultaneously with at least the 50 percent spectra in the vertical direction.

**B.5.1.8** If time-history analysis is used, at least three sets of ground motion time histories shall be applied.

**B.5.1.9** Deterministic fatigue analyses based on the linear accumulative damage theory shall normally be used for the fatigue assessment of a concrete GBS.

**B.5.1.10** Dynamic amplification effects shall be considered, where a GBS (including foundations) is sensitive to the hydrodynamic loads.

**RB.5.1.6** Force components for the SLE/DLE approach are used as vector values in design computations and should be combined using vectorial combination rules to determine the resultant design forces.

**CODE**

**COMMENTARY**

**B.5.1.11** Stochastic fatigue analyses shall be used for the fatigue assessment of a floating hull (including cyclic bond fatigue).

**RB.5.1.11** Deterministic fatigue analyses may also be accepted with adequate engineering justification.

**B.5.1.12** Thermal gradient analyses shall be performed to determine the thermal distribution to serve as the input of thermal stress analysis.

**B.5.1.13** Nonlinear analysis considering the stiffness reduction due to tensile and flexural cracking and moment redistribution shall be required for significant accidental boat/vessel impact and LNG/RLG leakage.

**B.5.2** *Local analysis*—A local detail analysis shall be performed in compliance with the criteria and requirements as specified in Chapter 7 of this code and subject to the guidance provided in the following sections of this code.

**B.6—Criteria and methodology of concrete sectional design**

**RB.6—Criteria and methodology of concrete sectional design**

**B.6.1** Adequate structural performance shall be demonstrated in the design documentation.

**B.6.2** The concrete sectional design of the GBS or floating hull shall conform to the following:

- a) Serviceability
- b) Ultimate strength
- c) Fatigue assessment
- d) Ductility
- e) Minimum amount of reinforcement

**B.6.3** The serviceability limit state considerations shall include crack control, water tightness, and deflection of the structural element.

**RB.6.3** The purpose of crack control is primarily to improve:

- a) Corrosion resistance of reinforcement
- b) Water tightness
- c) Adequate transfer of membrane shear force
- d) Durability by limiting ingress of aggressive agents

The ductility requirements are for preventing brittle failure or progressive failure under ductile level earthquake or accidental loads.

**B.6.4** The concrete section design shall be in accordance with the following design codes and subject to the additional requirements in B.6.5 through B.6.7:

- a) Chapter 7 of this code
- b) ACI 318

**RB.6.4** ACI 357R contains some guidelines on design requirements for offshore concrete structures that are not typically found in codes for building design and construction.

**B.6.5** Design methodology based on the direct calculated crack width control shall be acceptable for serviceability design. Limitation of calculated crack width and depth shall be in accordance with the applicable concrete design codes.

**B.6.6** Design of concrete ultimate shear strength under hydraulic pressure shall be subject to the requirements given in B.10.7.

**RB.6.7** Under membrane shear, the concrete may crack in a diagonal direction. Particularly under cyclic fatigue loads,

**B.6.7** Membrane shear design shall be in accordance with the general shear design method provided in applicable

**CODE**

concrete design codes. The contribution to shear strength from axial compression shall not be considered.

**B.7—Fatigue performance criteria**

A preliminary evaluation or simplified fatigue check shall normally be accepted before performing a detailed fatigue assessment. The fatigue resistance shall be considered as adequate if a preliminary evaluation indicates that stresses and stress ranges in concrete, reinforcement, and prestress tendon are limited within the requirements as specified.

**B.8—Design considerations during construction, transportation, and installation**

**B.8.1 General**—Design for the construction, transportation, and installation phases shall be in accordance with ACI 318 and the additional requirements in this section.

**B.8.2** In addition to the list of requirements in this section, a quality control plan shall be developed for concrete construction, including:

- a) Testing, batching, and mixing
- b) Conveying and placing concrete
- c) Construction joints
- d) Concrete curing
- e) Prestressing and grouting
- f) Form removal, surface repairs, and finished concrete

**B.8.3 Stages of construction**—Hydrostatic forces on external and internal surface shall be considered for each draft and stage of construction.

**COMMENTARY**

double pattern diagonal cracking may occur. Membrane shear strength shall normally be checked in all possible diagonal directions to verify that the shear transfer in any direction will not exceed the capacity in that direction.

**RB.7—Fatigue performance criteria**

Fatigue performance criteria is contained in Appendix C. ACI 357R also contains some additional guidelines for the fatigue resistance of concrete, reinforcing steel, and prestressing tendons used in fixed offshore concrete structures.

**RB.8—Design considerations during construction, transportation, and installation**

**RB.8.1** Design guidelines for the construction, transportation, and installation phases for offshore concrete structures can be found in ACI 357R.

**RB.8.3** Stages of construction that need to be considered include:

- a) First-stage prefabrication at an off-site location (graving docks, dry-docks, shipyards, finger piers, moles, barges, and fabrication yards)
- b) Load-out (skidding, launching, float-out, lift-out, sinking, and lowering)
- c) Intermediate-stage prefabrication (slip-forming afloat, work while grounded, topsides installation, and out-fitting)
- d) Transport (towing points, fatigue, motion response/stability, supplemental buoyancy/air cushions, compartmentation/damage control)
- e) Installation (sinking/lowering, positioning/station-keeping, and set-down)
- f) Final in-place construction (underbase grout, infill with granular ballast, and commissioning work)
- g) Decommissioning, terminal removal, or both

Depending on installation methodology, the size of the gravity base structure (GBS) or floating hull, and weight control, a GBS or floating hull can be entirely built at the first-stage prefabrication in a dry dock and directly towed to its final position. Alternatively, the initial portion could be built in a first-stage dry dock and then towed to an intermediate-stage prefabrication site (usually in a deeper water site) for continued construction.

## CODE

## COMMENTARY

**B.8.4** *Transportation and installation*

**B.8.4.1** For transportation and offshore installation, a Marine Warranty Surveyor shall be given the following information, as appropriate:

- a) Towing route
- b) Towing capacity
- c) Damage stability
- d) Stability and control during immersion
- e) Contact with the sea bed
- f) Grouting procedure and requirements for filling all voids between the base slab and the seabed

**B.8.4.2** The towing route will usually depend on the draft of the GBS or floating hull during tow and the physical oceanographic condition. The towing route shall be planned in detail considering the following:

- a) Water depth
- b) Tide range
- c) Currents
- d) Waves
- e) Winds
- f) Vertical and horizontal clearances of the towing channel

**B.8.4.3** The clearance between the bottom of the GBS or floating hull and seabed shall meet the marine operation requirements as specified in the applicable marine operation design codes, rules, set by the Marine Warranty Surveyor, or all.

If portions of the towing are in inland or near-shore waters, adequate clearance between the top of the structure and the underside of any bridges shall be specified.

**B.8.4.4** The water depth, tide range, and currents shall be adequately considered for the tow, plus the effect of heel due to wind and motion due to wave.

**B.8.4.5** If the towing route needs to be dredged, the vertical and horizontal clearances of the towing channel shall meet the requirements as specified in the aforementioned marine operation design codes.

**B.8.4.6** A drag survey shall be required to verify that the structure can be safely floated across the gate area of the dry dock.

**B.8.4.7** Because of the possibility of bad weather during the tow, offshore sheltered areas shall be planned for pending improvement of the weather to enable the tow/installation to proceed.

**B.8.5** *Moorings*

**B.8.5.1** Design for temporary moorings for both towing and completion afloat shall be considered including the following factors:

**RB.8.4.5** Due to the inherent weight of concrete structures, the clearance between the bottom of the concrete slab, or skirt, and the seabed during tow sometimes has to be kept to a minimum.

**RB.8.4.6** The towing route may also need to be surveyed by sonic profiling equipment to find shallow bars, ridges, pinnacles, and other marine hazards that may obstruct the tow.

## CODE

## COMMENTARY

- a) Orientation of structure and principle wave and current headings
- b) Tow route
- c) Navigation of nearby shipping vessels
- d) Failure of one or more mooring lines

**B.8.5.2** All affected parts of the structure shall be analyzed for static and dynamic loads imposed by mooring line loads during towing.

**B.8.5.2.1** Consideration shall be given to possible impact loads caused by sudden tightening or breakage of towing mooring lines.

**B.8.5.2.2** Anchor plates for attachments of mooring lines shall be adequately anchored for these dynamic loads and shall be designed for an ultimate strength criteria.

### **B.8.6** *Tolerances*

**B.8.6.1** Tolerances at different stages of construction shall be evaluated including consideration of the following:

- a) Tolerances during installation of the primary containment (either onshore or offshore)
- b) Inspection and verifications that the specified tolerances have been achieved
- c) Foundation tolerances

**B.8.6.2** During the construction phase at an intermediate-stage prefabrication site, a ballast control system shall be required to keep the gravity base structure (GBS) or concrete hull floating vertically.

**B.8.6.3** The tolerances of the GBS or floating hull geometry shall include the following:

- a) Maximum horizontal deviation of any point of the structure with respect to the projection of a corresponding point at the base of the structure
- b) Variation from prescribed radius for circular structures
- c) Variation from prescribed inside width dimensions for noncircular structures
- d) Variation from prescribed wall thickness

**B.8.7** *Weight control*—A weight control program for all GBS and floating hull terminals shall be established and include the following:

- a) A weight allowance for weight growth based on the current status of design, fabrication, or both
- b) A weight allowance to address unintentional flooding, leaking of cells, voids, and chambers that are intended to remain dry
- c) The influence of weight growth on the center of gravity and floating stability of the structure
- d) The influence of marine growth, ice accretion, or both, shall be accounted for



**CODE**

**COMMENTARY**

- e) Variations in the unit weight of concrete, dimension, geometry, and weight distribution
- f) The possible absorption of water by the concrete and presence of free water surface

**B.8.8** *Leak testing*

**B.8.8.1** During construction, the concrete hull shall be tested for leakage using an approved procedure such a hydrotesting, verification of construction joints, or both, using a vacuum box or a comparable system.

**B.8.8.2** If an air cushion is employed to reduce draft during float-out from the dry dock, the pressure of all air cushion units and compartments shall be tested for leakage.

**B.8.9** *Ballasting*

**B.8.9.1** The ballasting requirements and systems for all floating construction stages shall be evaluated.

**B.8.9.2** Contingency plans of buoyancy reserve shall be adequately developed for all possible accidents at all floating construction stages, including towing and installation.

**B.8.9.3** If an air cushion is employed to reduce draft during float-out from the dry dock, the design shall consider the effects of accidental loss of air pressure for one unit or compartment.

**B.9—Decommissioning**

**B.9.1** Wherever applicable, a step-by-step decommissioning procedure shall be developed for the following:

- a) Topside removal
- b) Breakout from the foundation
- c) Evaluation of frictional resistance on the skirts (if any)
- d) Evaluation of suction effects on the underside
- e) Weight calculation and rising velocity control
- f) Design of buoyancy and stability during refloatation

**B.9.2** The offshore terminal decommissioning shall be subject to the requirements as specified in applicable marine operation design codes, rules, as determined to be adequate by a Marine Warranty Surveyor, or all.

**B.10—Design for accidents**

**B.10.1** *General*—Design for accidents shall conform to the following criteria:

- a) The failure of an individual structural element directly exposed to accident loading does not result in a progressive failure in adjoining elements
- b) The failure of a critical structural element must be in a ductile manner

**RB.9—Decommissioning**

After its operational life, the terminal may be required to be decommissioned and removed.

**RB.10—Design for accidents**

## CODE

c) The remaining structural system, other than the damaged or failed structural element, can continue to carry the loads that are expected before repairs are completed

**B.10.2** *Boat/vessel impact*—For boat/vessel impact, the following shall be determined:

- a) The impact zone on the GBS or floating hull
- b) The mass and velocity of boat/vessel
- c) Protection of the primary containment system from the impact loads

**B.10.3** *Dropped objects*—For dropped objects, the following shall be determined:

- a) The drop area (the area shaded by topside module or deck shall be excluded)
- b) The mass and height of dropped objects

**B.10.4** *Design methodology*—Design methodology considering the energy distribution between: 1) the boat/vessel and the outer wall of the gravity basis structure (GBS) or floating hull; or 2) the large dropped object and the concrete deck shall be acceptable, provided that a sound engineering justification is presented. The additional following design requirements shall also be conformed to:

- a) The concrete strength shall be calculated based on the lower-bound limit theory.
- b) The minimum thickness of walls or slabs and the additional reinforcement in the tensile face shall be determined in accordance with applicable concrete design codes.

**B.10.5** *Fire*

**B.10.5.1** NFPA 59A and the provision of this design standard shall be applied wherever applicable.

**B.10.5.2** The effect of fire shall be determined based on fire temperature and time distribution curve.

## COMMENTARY

**RB.10.2** Additional information on collision and contact damage can be found in ISO 19903.

**RB.10.5** Liquefied natural gas and refrigerated liquefied gas (LNG/RLG) are explosive without flaming in some circumstances, and the exterior hull of the terminal may be exposed to cryogenic shock at the waterline due to LNG/RLG spills.

**RB.10.5.1** Descriptions of the fire exposure on LNG/RLG tanks can be found in 7.8.7 of NFPA 59A along with methods of fire protection in Chapter 12 and Appendix A of the same document.

**RB.10.5.2** The ISO hydrocarbon fire curve is typically used for evaluation of concrete subjected to a hydrocarbon fire. High-performance concrete can experience explosive spalling when subjected to fire. Some coarse aggregates, such as flint gravels, are more prone to spalling than others, and the concrete design should select one with a high resistance.

The use of polymeric fibers in shotcrete to reduce explosive spalling associated with fire is described in R6.6.5.10, and is also applicable to concrete. Information on the use of polymeric fibers to improve the concrete spalling associated with hydrocarbon fires can be found in ACI 318 and Bilodeau et al. (1997). Experimental evidence shows that the proportion of fibers required increases with the level of prestress.

**CODE**

**COMMENTARY**

**B.10.5.3** The compartmentation of the GBS or floating hull located in the fire hazard zone shall be designed for the fire effect associated with the following:

- a) Operating (environmental condition) wind, wave, and current during fire
- b) Design (environmental condition) wind, wave, and current after the fire and before repairs are made

**B.10.5.4** The design to determine the concrete strength under high temperature shall be in compliance with the applicable concrete design codes.

**B.10.6** *Explosion*

**B.10.6.1** The design for explosion in enclosed concrete compartments shall be based on the following:

- a) The shock pressure depends on the enclosed volume and the ratio of easily removable surface to the total surface.
- b) The enclosing structures are assumed to transfer these imposed loads to the adjacent structures.
- c) The maximum explosion load may be limited to the ultimate strength of these adjacent structures.
- d) The structure shall be designed for the design (environmental condition) wind, wave, and current after the explosion and before repairs are made..

**B.10.6.2** The design for preventing the failure of the structure due to explosions shall be combined with different fire scenarios.

**RB.10.6.2** LNG/RLG explosions can happen concurrently with different fire scenarios in many circumstances.

**B.10.7** *Hydraulic pressure differentials*—Any compartment of the concrete gravity base structure (GBS) or floating hull subjected to hydraulic pressure due to ballasting or buoyancy during construction, installation, transportation, and operation shall be designed to resist the maximum pressure difference in accordance with the following criteria:

- a) The factored design pressure difference shall be the maximum planned, but limited to physically possible values.
- b) Wherever an intended pressure difference is taken into account, the temporary loss of that difference during the operation phase or due to unintended flooding shall be considered.
- c) The design accident load shall be combined with the other maximum imposed loads, such as the associated environmental loads and topside loads.

**B.10.8** *Out-of-plane shear failure*

**RB.10.8** The possible failure of a concrete compartment wall resulting from the unintended loss of pressure difference due to ballasting or buoyancy is mainly an out-of-plane shear failure in a sudden and brittle manner. Design guidelines for consideration of shear failures in offshore concrete structures can be found in Wang et al. (2003).

**CODE**

**COMMENTARY**

**B.10.8.1** To prevent out-of-plane shear failure, the design requirements for shear failure given in the following codes shall be applied to determine the concrete shear strength:

- a) Chapter 7 of this code
- b) ACI 318

**B.10.9** *Seismic*

**B.10.9.1** The design for the safe shutdown earthquake (SSE) or ductility level earthquake (DLE) shall be considered as accidental limit state (ALS).

**B.10.9.2** The stored liquefied natural gas and refrigerated liquefied gas (LNG/RLG) in the containment structure shall not leak out after the SSE or DLE.

## CODE

## COMMENTARY

## APPENDIX C—FATIGUE PERFORMANCE

**C.1—Scope**

The requirements in this appendix are intended to supplement the general requirements for reinforced concrete and prestressed concrete design and construction given in ACI 318, ACI 350, ACI 301, other national and international codes, and this code. Although this appendix focuses on offshore gravity base structures (GBS) and floating concrete offshore liquefied natural gas and refrigerated liquefied gas (LNG/RLG) terminals, the fatigue considerations and analysis methods are also applicable to onshore LNG and RLG structures where fatigue is a consideration.

**C.2—General**

Wherever applicable, design criteria and requirements, as specified in the other chapters of this code, shall be used to design the concrete LNG or RLG tank, the GBS, or floating hull.

**C.3—Fatigue performance criteria**

**C.3.1** A preliminary evaluation or simplified fatigue check shall normally be accepted before performing a detailed fatigue assessment. The fatigue resistance shall be considered adequate if a preliminary evaluation indicates that stresses and stress ranges in concrete, reinforcement, and prestressed tendons are limited within the requirements as specified.

**C.3.2** A minimum expected fatigue life of at least twice the design life shall be considered acceptable.

**RC.1—Scope**

This appendix gives guidance on fatigue to individuals charged with design and construction of both onshore and offshore LNG and RLG structures. Although the focus is principally on offshore LNG and RLG structures, the same criteria, design, construction, commissioning, and decommissioning requirements also apply to onshore LNG and RLG structures.

Offshore LNG and RLG terminals can be fixed (including GBS and pile founded) or floating structures (including floating storage units [FSUs], floating storage and regasification units [FSRUs], and buoys for custom carrier vessels), and can be built from either concrete or steel.

Additional information on offshore LNG and RLG structures is contained in Appendix B. For additional information of the fatigue behavior of concrete elements and fatigue analysis, refer to ACI 215R and ACI Committee 215 (1974). ACI 357R contains some guidelines for the fatigue resistance of concrete, reinforcing steel, and prestressing tendons used in fixed offshore concrete structures.

**RC.2—General**

The design of the concrete GBS or floating hull for offshore LNG/RLG terminals will be different than the design of the concrete structures for onshore LNG/RLG containments due to the considerations given in B.1 of this code.

The design philosophy concerning a primary containment tank failure or leakage of the LNG/RLG containment system for an offshore LNG/RLG terminal has been influenced by both onshore codes and LNG/RLG ship rules. The onshore codes require that a secondary containment system be capable of containing the full liquid contents of the primary tank with either a bund or double/full containment system such as a prestressed concrete cylindrical wall. In contrast, ship rules accept a leak-before-failure philosophy for some types of tanks. Whether or not the inner wall of concrete hull should be designed as a secondary containment based on a leak-before-failure philosophy depends on the following:

- a) The logistic, degree, and mechanism of the integration between the containment system and the concrete hull
- b) The approval from national regulatory and owner's requirement

**RC.3—Fatigue performance criteria**

**RC.3.1** Simplified fatigue checks are normally based on the design environmental waves (extreme waves). A structural element is considered to have adequate fatigue strength if it has at least  $2 \times 10^6$  cycles of fatigue resistance under the extreme wave load.

## CODE

**C.3.3** To estimate the cumulative fatigue damage under variable amplitude stresses, a recognized cumulative rule shall be used. The deterministic approach is usually considered. If any of the conditions of C.3.5 are exceeded, an in-depth fatigue analysis shall be performed.

**C.3.3.1** The fatigue performance of the structure under unfactored operating loads shall be considered, and acceptable engineering methods shall be used in assessing the performance.

**C.3.3.2** If an in-depth fatigue analysis is not being used, fatigue strength shall be considered satisfactory if under the unfactored operating loads, conditions described in C.3.3 and C.3.4 are satisfied.

**C.3.3.3** The cyclic load (such as waves and seismic) distribution shall be determined based on the expected fatigue life. Multiple wave (or other load) directions and enough stress blocks shall be considered.

**C.3.3.4** The ratio of reinforcement fatigue damage shall be required to be less than 1.0, and the ratio of concrete is preferred to be less than 0.5.

**C.3.3.5** The detailed fatigue check shall consider both membrane fatigue and shear fatigue failure.

**C.3.3.5.1** For membrane fatigue, the concrete shall be checked in the direction of each principal stress, strain, or both, on both its faces. It shall be assumed that there is neither membrane tensile stress nor more than 200 psi flexural tensile stress in the concrete.

**C.3.3.5.2** For shear fatigue, concrete is checked according to the compressive failure and tensile failure models, respectively.

**C.3.3.5.3** Where maximum shear exceeds the allowable shear of the concrete alone, and where the cyclic range is more than half the maximum allowable shear in the concrete alone, all shear shall be taken by reinforcement.

## COMMENTARY

**RC.3.3** For an in-depth fatigue analysis, the possible reduction of material strength is to be taken into account on the basis of appropriate data (S-N curves) corresponding to the 95th percentile of specimen survival. In this regard, consideration is to be given not only to the effects of fatigue induced by normal stresses, but also to fatigue effects due to shear and bond stresses under unfactored load combinations.

Miner's rule is an acceptable method for the cumulative fatigue damage analysis. The rule states that where there are  $k$  different stress magnitudes in a spectrum  $S_i$  ( $1 \leq i \leq k$ ), each contributing  $n_i(S_i)$  cycles, then if  $N_i(S_i)$  is the number of cycles to failure of a constant stress reversal  $S_i$ , failure occurs when

$$\sum_{i=1}^k \frac{n_i}{N_i} = C$$

where  $C$  is an experimentally determined coefficient, usually varying between 0.7 and 2.2. For design purposes,  $C$  is usually assumed to equal to 1.0.

**RC.3.3.5.1** Special material factors need to be applied to concrete S-N curves to account for water ingress into concrete cracks in submerged and splash zones.

**RC.3.3.5.3** When determining the allowable shear of the concrete alone, the influence of permanent compressive stress may be taken into account.

**CODE**

**C.3.4** In prestressed members containing unbonded reinforcement, special attention shall be given to the possibility of fatigue in the anchorages or couplers that may be subject to corrosive action.

**C.3.5** The fatigue life shall be analyzed for each steel reinforcing bar layer and each prestressing layer.

**C.3.5.1** The stress range in reinforcing or prestressing steel shall not exceed 20,000 psi (or 10,000 psi where reinforcement is bent, welded, or spliced).

**C.3.5.2** The compressive concrete stress range shall not exceed  $0.50f'_c$ .

**C.3.5.3** If lap splices of reinforcement or pretensioning anchorage development are subjected to cyclic tensile stresses greater than 50 percent of the allowable static stress, the lap length or prestressing development length shall be increased by 50 percent.

**C.3.5.4** If lap splices of reinforcement or pretensioning anchorage development are subjected to cyclic tensile stresses greater than 50 percent of the allowable static stresses, the lap length or prestressing development length shall be increased by 50 percent.

**C.3.6** The fatigue damage induced during transport (refer to B.8.4) and unintended loss of pressure difference shall also be accounted for in the fatigue life calculations.

**C.3.7** Consideration of hybrid fabrication, including transfer of possible interface stresses between any structural steel element and its supporting concrete member, shall be included in the design.

**COMMENTARY**

**RC.3.4** Unbonded tendons should be composed of encapsulated systems developed for corrosive environments.

**RC.3.5** Special material factors need to be applied to S-N curves of reinforcement and couplers to account for stress concentration on bent reinforcement and mechanical couplers. The S-N curves of reinforcement and mechanical couplers are usually determined based on dynamic tests.

**RC.3.5.3** For these calculations, it is assumed that the bond stress does not exceed 50 percent of that permitted for static loads.

## CODE

## COMMENTARY

## COMMENTARY REFERENCES

Committee documents are listed first by document number and year of publication followed by authored documents listed alphabetically.

*American Concrete Institute*

- 201.2R-08—Guide to Durable Concrete
- 209R-92—Prediction of Creep, Shrinkage, and Temperature Effects in Concrete Structures
- 209.1R-05—Report on Factors Affecting Shrinkage and Creep of Hardened Concrete
- 215R-74(92)—Considerations for Design of Concrete Structures Subjected to Fatigue Loading
- 222R-01—Protection of Metals in Concrete against Corrosion
- 228.2R-98—Nondestructive Test Methods for Evaluation of Concrete in Structures
- 301-10—Specifications for Structural Concrete
- 309R-05—Guide for Consolidation of Concrete
- 318-11—Building Code Requirements for Structural Concrete and Commentary
- 336.1R-01—Specification for the Construction of Drilled Piers
- 347-04—Guide to Formwork for Concrete
- 349-06—Code Requirements for Nuclear Safety Related Concrete Structures and Commentary
- 350-06—Code Requirements for Environmental Engineering Concrete Structures
- 350.2R-04—Concrete Structures for Containment of Hazardous Materials
- 357R-84—Guide for the Design and Construction of Fixed Offshore Concrete Structures
- 372R-03—Design and Construction of Circular Wire- and Strand-Wrapped Prestressed Concrete Structures
- 373R-97—Design and Construction of Circular Prestressed Concrete Structures with Circumferential Tendons (withdrawn 2012)
- 506R-05—Guide to Shotcrete
- 506.2-95—Specification for Shotcrete
- 515.1R-79(85)—Guide to the Use of Waterproofing, Dampproofing, Protective, and Decorative Barrier Systems for Concrete (withdrawn 2008)
- 543R-00—Design, Manufacture, and Installation of Concrete Piles
- 544.1R-96—Report on Fiber Reinforced Concrete
- 544.3R-08—Guide for Specifying, Proportioning, Mixing, and Production of Fiber-Reinforced Concrete
- 544.4R-88—Design Considerations for Steel Fiber Reinforced Concrete

*American Petroleum Institute (API)*

- API 620-08—Design and Construction of Large, Welded, Low-Pressure Storage Tanks
- API 650-07—Welded Tanks for Oil Storage

*American Shotcrete Association*

- CCS-4(08)—Shotcrete for the Craftsman



**CODE**

**COMMENTARY**

*American Society of Civil Engineers (ASCE)*

4-98—Seismic Analysis of Safety-Related Nuclear Structures

7-05—Minimum Design Loads for Buildings and Other Structures

20-96—Standard Guidelines for the Design and Installation of Pile Foundations

*American Society of Mechanical Engineers*

B31.3-2006—Process Piping

*American Water Works Association*

D110-04—Wire- and Strand-Wound, Circular, Prestressed Concrete Water Tanks

*American Welding Society*

D.1.1/D.1.1M-08—Structural Welding Code—Steel

B2.1-09—Base Metal Grouping for Welding Procedure and Performance Qualification

*ASTM International*

A416/A416M-10—Standard Specification for Steel Strand, Uncoated Seven-Wire for Prestressed Concrete

A615/A615M-09—Standard Specification for Deformed and Plain Carbon Steel Bars for Concrete Reinforcement

A706/A706M-09—Standard Specification for Low Alloy Steel Deformed and Plain Bars for Concrete Reinforcement

C227-10—Standard Test Method for Potential Alkali Reactivity of Cement Aggregate Combinations (Mortar Bar Method)

C289-07—Standard Test Method for Potential Alkali-Silica Reactivity of Aggregates (Chemical Method)

C311-11—Standard Test Methods for Sampling and Testing Fly Ash or Natural Pozzolans for Use in Portland Cement Concrete

C441/C441M-11—Standard Test Method for Effectiveness of Pozzolans or Ground Blast Furnace Slag in Preventing Excessive Expansion of Concrete Due to the Alkali Silica Reaction

C494/C494M-11—Standard Specification for Chemical Admixtures for Concrete

C1116/C1116M-10—Standard Specification for Fiber Reinforced Concrete

C1202-10—Standard Test Method for Electrical Indication of Concrete's Ability to Resist Chloride Ion Penetration

C1260-07—Standard Test Method for Potential Alkali Reactivity of Aggregates (Mortar-Bar Method)

C1602/C1602M-06—Standard Specification for Mixing Water Used in the Production of Hydraulic Cement Concrete

D1647-89(1996)—Standard Test Methods for Resistance of Dried Films of Varnishes to Water and Alkali (withdrawn)

D3966-07—Standard Test Methods for Deep Foundations Under Lateral Load

D4611-08—Standard Test Method for Specific Heat of Rock and Soil

## CODE

## COMMENTARY

D6760-08—Standard Test Method for Integrity Testing of Concrete Deep Foundations by Ultrasonic Crosshole Testing

E96/E96M-10—Standard Test Methods for Water Vapor Transmission of Materials

G16-95(2010)—Standard Guide for Applying Statistics to Analysis of Corrosion Data

G46-94(2005)—Standard Guide for Examination and Evaluation Pitting Corrosion

*British Standards Institute (BSI)*

EN 1473—Installation and Equipment for Liquefied Natural Gas: Design of Onshore Installations

EN 14620—Design and Manufacture of Site Built, Vertical, Cylindrical, Flat-Bottomed, Steel Tanks for the Storage of Refrigerated Liquefied Gases with Operating Temperatures between 0 °C and –165 °C, Part 1, General

7777-2—Flat Bottomed, Vertical, Cylindrical Storage Tanks for Low Temperature Service Specification for the Design and Construction of Single, Double and Full Containment Metal Tanks for the Storage of Liquefied Gas at Temperatures Down to –165 °C

8110-2—Structural Use of Concrete — Part 2: Code of Practice for Special Circumstances

*International Organization for Standardization (ISO)*

19903—Petroleum and Natural Gas Industries—Fixed Concrete Offshore Structures

4624—Paints and Varnishes — Pull-Off Test for Adhesion

*National Fire Protection Agency (NFPA)*

59A—Standard for the Production, Storage, and Handling of Liquefied Natural Gas (LNG)

*Precast/Prestressed Concrete Institute (PCI)*

MNL-116—Manual for Quality Control of Plants and Production of Precast and Prestressed Concrete Products

*Process Industry Practices (PIP)*

STE03020-05—Guidelines for Tank Foundation Designs

STE02465-05—Auger-Cast-In-Place Piles Design Guidelines

STS02380-06—Application of ACI 336.1-01, Specification for the Construction of Drilled Piers

*U.S. Army Corps of Engineers (USACE)*

CRD-C 39-81—Test Method for Coefficient of Linear Thermal Expansion of Concrete

*U.S. Occupational Safety and Health Administration (OSHA)*

29 CFR 1910.146—Permit-Required Confined Spaces

ACI Committee 215, 1974, “Guide for Design of Concrete Structures Subjected to Fatigue Loading,” ACI JOURNAL, *Proceedings* V. 71, No. 3, Mar., pp. 97-121.

AGA, 1992, *Purging Principles and Practice*, American Gas Association Manual, Arlington, VA.

CODE

COMMENTARY

API, 2000, "Recommended Practice for Planning, Designing and Constructing Fixed Offshore Platforms—Working Stress Design," *API Recommended Practice 2A-WSD*, 21st edition, Dec.

Bamforth, P. B., 1984, "Concrete Used for Storage of Cryogenic Liquids with Special Reference to Temperature Effects," *Concrete Storage Structures*, The Concrete Society (UK), pp. 73-84

Bamforth, P. B.; Murray, W. T.; and Browne, R. D., 1983, "The Application of Concrete Property Data at Cryogenic Temperature to LNG Tank Design," *Proceedings of the 2nd International Conference on Cryogenic Concrete*, Amsterdam, the Netherlands.

Bangash, M. Y. H., 2008, *Shock, Impact and Explosion: Structural Analysis and Design*, first edition, Springer, 1366 pp.

Barbe, B., and Costaz, J. L., 1991, "Design and Behavior of French Containments," *Nuclear Engineering and Design*, V. 125, No. 1, pp. 57-73.

Barber, R. B., 1973, "Steel Rod/Concrete Slab Impact Test (Experimental Simulation)," Bechtel Corp., San Francisco, CA, Oct.

Berner, D., and Gerwick, B. C., 2001, "Large Floating Concrete LNG/LPG Offshore Platforms," UJNR/MFP 24th Joint Meeting, Nov., HI.

Bilodeau, A.; Chevrier, R.; Malhotra, V. M.; and Hoff, G. C., 1997, "Mechanical Properties, Durability and Performance in Hydrocarbon Fire of High-Strength Semi-Lightweight Concrete," *Proceedings of the Fourth CANMET/ACI International Conference on Durability of Concrete*, SP-170, V. 2, American Concrete Institute, Farmington Hills, MI, pp. 1157-1195.

Briaud, J. L., and Tucker, L. M., 1997, "Design and Construction Guidelines for Downdrag on Uncoated and Bitumen-Coated Piles," *NCHRP Report 393*, Transportation Research Board, National Academy Press, Washington, DC, 124 pp.

Bruggeling, A. S. G., 1978, "Materials for Prestressing and Reinforcement for use under Cryogenic Conditions—Report of Ad-Hoc Committee on Cryogenic Problems," *Proceedings*, 8th FIP Congress, Wembley, London, UK.

Closner, J. J., and Legatos, N. A., 1978, "Prestressed Concrete at Cryogenic Temperatures," *Proceedings*, 8th FIP Congress, Part III, Wembley, London, UK, pp. 95-103.

Closner, J. J.; Corvini, R. H.; and Marchaj, T. J., 1976, "Purging, Cool-Down and Performance Testing of Prestressed Concrete LNG Containers," *AGA Operating Section Proceedings*, May, pp. T210-T218.

Crawford, D. B.; Durr, C. A.; and Handman, S. E., 1985, "Inside an LNG Storage Tank," *Gastech 85*, Nov.

Department of Defense, 1990, "Structures to Resist the Effects of Accidental Explosions," Department of the Army (TM 5-1300), Navy (NAVFAC P-397), and Air Force (AFR 88-22), U.S. Department of Defense, Washington, DC, Nov.

DNV, 2004, "Concrete LNG Terminal Structures and Containment Systems," Offshore Standard DNV-OS-C503, Det Norske Veritas (DNV), Hovik, Oslo, Norway, Oct.

## CODE

## COMMENTARY

Doi, A.; Tomioka, H.; Tanaka, Y.; and Kurauchi, M., 1974, "Physical Properties of Prestressing Wire at Low Temperature," *Report DRG 75-04*, Shinko Wire Co. Ltd.

Duncan, J. M., and D'Orazio, T. B., 1984, "Stability of Steel Storage Tanks," *Journal of Geotechnical Engineering*, V. 110, No. 9, pp. 1219-1238.

Edvardsen, C., 1999, "Water Permeability and Autogenous Healing of Cracks in Concrete," *ACI Materials Journal*, V. 96, No. 4, July-Aug., pp. 448-454.

Elices, M., and Sleigh, G., 1978, "Steels for Prestressed Concrete Structures for Cryogenic Applications," *Proceedings*, 8th FIP Congress, Wembley, London.

Fellenius, B. H., 2006, "Results from Long-Term Measurement in Piles of Drag Load and Downdrag," *Canadian Geotechnical Journal*, V. 43, No. 4, Apr., pp. 409-430.

FIP, 1974, "Recommendations for the Approval, Supply and Acceptance of Steels for Prestressing Tendons," *fib* (CEB-FIP), Lausanne, Switzerland.

FIP, 1981, "Acceptance and Application of Post-Tensioning Systems," *fib* (CEB-FIP), Lausanne, Switzerland.

FIP, 1982a, "Cryogenic Behavior of Materials for Prestressed Concrete," *fib* (CEB-FIP), Lausanne, Switzerland, May.

FIP, 1982b, "Preliminary Recommendations for the Design of Prestressed Concrete Containment Structures for the Storage of Refrigerated Liquid Gases (RLG)," *Guide to Good Practice*, *fib* (CEB-FIP), Lausanne, Switzerland, Sept.

FIP, 1988, "Assessment of Mechanical Properties of Structural Materials for Cryogenic Applications, Commission 2: Prestressing Steels and Systems," *fib* (CEB-FIP), Lausanne, Switzerland.

Hanaor, A., 1982, "Testing of Concrete Specimens for Permeability at Cryogenic Temperatures," *Magazine of Concrete Research*, V. 34, No. 120, Sept., pp. 155-162.

Hanaor, A., 1985, "Microcracking and Permeability of Concrete to Liquid Nitrogen," *ACI JOURNAL*, *Proceedings* V. 82, No. 2, Mar.-Apr., pp. 147-153.

Hanaor, A., and Sullivan, P., 1983, "Factors Affecting Concrete Permeability to Cryogenic Fluids," *Magazine of Concrete Research*, V. 35, No. 124, Sept., pp. 142-150.

Hirth, H. C. Jr., 1982, "Thermal Properties of Concrete at Extreme Temperatures," PhD dissertation, University of California at Berkeley, Berkeley, CA.

Hoff, G. C., 1998, "Hydrocarbon Fire Resistance of High-Strength Normal Weight and Lightweight Concretes Incorporating Polypropylene Fibers," *Proceedings of the International Symposium on High-Performance and Reactive Powder Concretes*, V. 4, University of Sherbrooke, QC, Canada, pp. 271-296.

Hollema, D. A., and Olson, L. D., 2003, "Crosshole Sonic Logging and Velocity Tomography Imaging of Drilled Shaft Foundations," *Proceedings BB 85-CD*, International Symposium (NDT-CE 2003) on Non-Destructive Testing in Civil Engineering, Berlin, Germany, 7 pp.

Housner, G. W., 1982, "Dynamic Analysis of Fluids in Containers Subject to Acceleration," *ASCE Technical Seminar*, Los Angeles, CA.

## CODE

## COMMENTARY

Hurd, M. K., 2005, *Formwork for Concrete*, SP-4, seventh edition, American Concrete Institute, Farmington Hills, MI, 500 pp.

Jankov, A. D.; Shanahar, J. A.; and White, M. P., 1976, "Missile Tests of Quarter-Scale Reinforced Concrete Barriers," *Proceedings from A Symposium on Tornadoes, Assessment of Knowledge and Implications for Man*, Texas Technical University, Lubbock, TX, pp. 605-622.

Jiang, D.; Wang, G.; Montaruli, B. C.; and Richardson, K. L., 2004a, "Concrete Offshore LNG Terminals—A Viable Solution and Technical Challenges," Offshore Technology Conference, OTC 16124, Houston, TX.

Jiang, D.; Datta, I.; and Roraas, H., 2004b, "Concrete Offshore LNG Terminals—A Trend of Technical Solution," Society of Naval Architects and Marine Engineers 14th Symposium, Houston, TX.

Kasami, H.; Tanaka, Y.; Kishima, Y.; and Yamane, S., 1981, "Properties of Concrete at Very Low Temperatures," *Proceedings of the First International Conference on Cryogenic Concrete*, The Concrete Society, Mar.

Kennedy, R. P., 1976, "A Review of the Procedures for the Analysis and Design of Concrete Structures to Resist Missile Impact Effects," *Nuclear Engineering and Design*, V. 37, No. 2, pp. 183-203.

Klein, F.; Hoffman, E. S.; and Rice, P. F., 1981, "Application of Strength Design Methods to Sanitary Structures," *Concrete International*, V. 3, No. 4, Apr., pp. 35-40.

Klysz, G.; Balayssac, J. P.; and Laurens, S., 2004, "Spectral Analysis of Radar Surface Waves for Non-Destructive Evaluation of Concrete Cover," *NDT & E International*, V. 37, No. 3, pp. 221-227.

Krstulovic-Opara, N., 2005, "Performance of Reinforced and Prestressed Concretes in Cryogenic Environments," *Mindess Symposium; Concrete: Bridging Materials and Structures*, Third International Conference on Construction Materials—Performance, Innovations and Structural Applications, ConMat05, Vancouver, BC, Canada.

Krstulovic-Opara, N., 2007, "Liquefied Natural Gas Storage: Material Behavior of Concrete at Cryogenic Temperatures," *ACI Materials Journal*, V. 104, No. 3, May-June, pp. 297-306.

Krybar, 1981, "Technical Data Sheet from Arbed," Jan.

Legatos, N. A., and Marchaj, T. J., 1994, "LNG Storage Tanks—Dewpoint Criteria for Purging into Service," *Proceedings from Gastech 94*, Kuala Lumpur, Malaysia.

Lentz, A. E., and Monfore, G. E., 1966, "Thermal Conductivity of Concrete at Very Low Temperatures," *PCA R&D Journal*, pp. 27-35.

Lloyd's, 2004, "Classification and Certification of Offshore Gravity Based Liquefied Gas Terminals—Guide Notes," *Lloyd's Register*, Apr., 98 pp.

Lysmer, J.; Tabatabaie-Raissi, M.; Tajirian, F.; Vahdani, S.; and Ostadan, F., 1981, "SASSI: A System for Analysis of Soil-Structure Interaction Problems," *Report UCB/GT81-02*, University of California, Berkeley, Berkeley, CA.

## CODE

## COMMENTARY

Malhotra, P., 1995, "Base Uplifting Analysis of Flexibly Supported Liquid Storage Tanks," *Earthquake Engineering & Structural Dynamics*, V. 24, No. 12, Dec., pp. 591-607.

Malhotra, P.; Wenk, T.; and Wieland, M., 2000, "Simple Procedure for Seismic Analysis of Liquid-Storage Tanks," *Structural Engineering Journal*, IASBE, V. 10, No. 3, pp. 197-201.

Malhotra, V. M., ed., 2002, *Innovations in Design with Emphasis on Seismic, Wind, and Environmental Loading; Quality Control and Innovations in Materials/Hot-Weather Concreting*, SP-209, American Concrete Institute, Farmington Hills, MI, 924 pp.

Marshall, A. L., 1982, "Cryogenic Concrete," *Cryogenics*, Nov, p. 555.

MCEER, 2001, "Recommended LRFD Guidelines for the Seismic Design of Highway Bridges, Part I: Specifications," prepared under the MCEER Highway Project 94, Task F3-1, Nov.

Nippon Kokan, 1980, *Technical Document no. 221-037*, Nippon Kokan Co., Ltd.

Nippon Steel Corporation, 1980, "Production and Properties of Low Carbon 25Mn 5Cr 1Ni Austenitic Steel," *Nippon Research Report*, pp. 1-19.

PCA, 1986, "Effects of Various Substances on Concrete and Protective Systems," *Information Sheet* No. IS001T, Portland Cement Association, Skokie, IL, 24 pp.

Planas, J.; Elices, M.; Sanchez-Galvez, V.; and Mestre, A., 1978, "Mechanical Properties of Prestressing Steel at Cryogenic Temperatures," *Hormigon y Acero*, No. 126.

Post Tensioning Institute, 2006, *Post-Tensioning Manual*, sixth edition, PTI, Farmington Hills, MI, 354 pp.

Richart, F. E.; Hall, J. R.; and Woods, R. D., 1970, *Vibrations of Soil and Foundations*, Prentice Hall, Inc.

Rostasy, F. S., 1988, "Assessment of Mechanical Properties of Structural Materials for Cryogenic Applications, Commission 2: Prestressing Steels and Systems," *Special Report SR2*, Fédération Internationale de la Précontrainte (FIP), Lausanne, Switzerland, 92 pp.

Rostasy, F. S., and Wiedemann, G., 1979, "Behavior of Mortar and Concrete at Extremely Low Temperatures," *Cement and Concrete Research*, V. 9, No. 3, pp. 365-376.

Rostasy, F. S., and Wiedemann, G., 1980, "Stress-Strain Behavior of Concrete at Extremely Low Temperatures," *Cement and Concrete Research*, V. 10, pp. 565-572.

Rostasy, F. S., and Wiedemann, G., 1981, "Stress, Deformation and Thermal Strains of Concrete at Cryogenic Conditions," *Proceedings of the 1st International Conference on Cryogenic Concrete*, Newcastle, UK.

Rotz, J. V., 1976a, "Evaluation of Tornado Missile Impact Effects on Structures," *Proceedings of the Symposium on Tornadoes, Assessment of Knowledge and Implications for Man*, Texas Technical University, Lubbock, TX, June, pp. 363-374.

Rotz, J. V., 1976b, "Results of Missile Impact Tests on Reinforced Concrete Panels," *Proceedings of the Second Specialty Conference on Structural Design of Nuclear Plant*

## CODE

## COMMENTARY

*Facilities*, American Society of Civil Engineers, New York, pp. 720-738.

Schnabel, P. B.; Lysmer, J.; and Seed, H. B., 1972, "SHAKE—A Computer Program for Earthquake Response Analysis of Horizontally Layered Sites," *Report No. EERC 72-12*, Earthquake Engineering Research Center, University of California at Berkeley, Berkeley, CA, 92 pp.

Stephenson, A. E., 1976, "Full-Scale Tornado-Missile Impact Tests (Interim Report)," *Report No. NP-148*, Sandia Laboratories, Tonopah, NV, 21 pp.

Suehiro, K., and Nitta, H., 1979, "Low Temperature Properties of Prestressing Steel," *Neturen Company Research Report No. P 7026*.

Tarakada, R. R.; Durr, C. A.; and Crawford, D. B., 1981, "Condensation in the Annulus of a Double-Walled Cryogenic Storage Tank," *Cryogenic Engineering Conference*, San Diego, CA.

The Concrete Society, 2002, "Durable Post-Tensioned Bridges," *Report TR47*, The Concrete Society, Blackwater, Camberley, Surrey, UK, Aug., 70 pp.

Trotter, H.; Turner, F.; Sullivan, P.; and Brooks, W., 1975, "Behaviour of Prestressed Concrete Materials at Very Low Temperatures," *Build International*, V. 8, pp. 65-81.

USEPA, 2002, "Drinking Water Standard," 2002 Code of Federal Regulations, Title 40, V. 19, Protection of the Environment, Chapter 1, Environmental Protection Agency (EPA), Part 141, National Primary Drinking Water Regulations.

U.S. NRC, 1973, "Regulatory Guide 1.61—Damping Values for Seismic Design of Nuclear Power Plants," U.S. Nuclear Regulatory Commission, Washington, DC, 12 pp.

Vassallo, F. A., 1975, "Missile Impact Testing of Reinforced Chicanery Panels," *Report No. HC-5609-D-1*, Buffalo, NY.

Veletsos, A. S., 1984, "Seismic Response and Design of Liquid Storage Tanks: Guidelines for the Seismic Design of Oil and Gas Pipeline Systems," *Technical Councils on Lifeline Earthquake Engineering*, American Society of Civil Engineers (ASCE), New York, pp. 255-370, 443-461.

Venendaal, R., 1979, "Dryout, Cool-down Keyed Cove Point Commissioning," *Pipeline and Gas Journal*, June, p. 38.

Vetter, C. P., "Stress in Reinforced Concrete Due to Volume Changes," *Transactions of ASCE*, V. 98, 1933, pp. 1039-1053.

Wang, G.; Jiang, D.; and Shin, Y., 2003, "Consideration of Collision and Contact Damage Risks in FPSO Structural Designs," *Offshore Technology Conference*, OTC15316, May, Houston, TX.

Whiteley, J.; Armstrong, B.; and Welburn, R., 1981, "Reinforcing and Prestressing Steels for Cryogenic Applications," *First International Conference on Cryogenic Concrete*, Newcastle upon Tyne, Mar.

Williams, M. S., 1994, "Modeling of Local Impact on Plain and Reinforced Concrete," *ACI Structural Journal*, V. 91, No. 2, Mar.-Apr., pp. 178-187.



**American Concrete Institute®**  
*Advancing concrete knowledge*

As ACI begins its second century of advancing concrete knowledge, its original chartered purpose remains “to provide a comradeship in finding the best ways to do concrete work of all kinds and in spreading knowledge.” In keeping with this purpose, ACI supports the following activities:

- Technical committees that produce consensus reports, guides, specifications, and codes.
- Spring and fall conventions to facilitate the work of its committees.
- Educational seminars that disseminate reliable information on concrete.
- Certification programs for personnel employed within the concrete industry.
- Student programs such as scholarships, internships, and competitions.
- Sponsoring and co-sponsoring international conferences and symposia.
- Formal coordination with several international concrete related societies.
- Periodicals: the ACI Structural Journal and the ACI Materials Journal, and Concrete International.

Benefits of membership include a subscription to Concrete International and to an ACI Journal. ACI members receive discounts of up to 40% on all ACI products and services, including documents, seminars and convention registration fees.

As a member of ACI, you join thousands of practitioners and professionals worldwide who share a commitment to maintain the highest industry standards for concrete technology, construction, and practices. In addition, ACI chapters provide opportunities for interaction of professionals and practitioners at a local level.

**American Concrete Institute**  
**38800 Country Club Drive**  
**Farmington Hills, MI 48331**  
**U.S.A.**

**Phone: 248-848-3700**  
**Fax: 248-848-3701**

**[www.concrete.org](http://www.concrete.org)**



# Code Requirements for Design and Construction of Concrete Structures for the Containment of Refrigerated Liquefied Gases and Commentary

## The AMERICAN CONCRETE INSTITUTE

was founded in 1904 as a nonprofit membership organization dedicated to public service and representing the user interest in the field of concrete. ACI gathers and distributes information on the improvement of design, construction and maintenance of concrete products and structures. The work of ACI is conducted by individual ACI members and through volunteer committees composed of both members and non-members.

The committees, as well as ACI as a whole, operate under a consensus format, which assures all participants the right to have their views considered. Committee activities include the development of building codes and specifications; analysis of research and development results; presentation of construction and repair techniques; and education.

Individuals interested in the activities of ACI are encouraged to become a member. There are no educational or employment requirements. ACI's membership is composed of engineers, architects, scientists, contractors, educators, and representatives from a variety of companies and organizations.

Members are encouraged to participate in committee activities that relate to their specific areas of interest. For more information, contact ACI.

**[www.concrete.org](http://www.concrete.org)**

