

Fall Protection in Construction

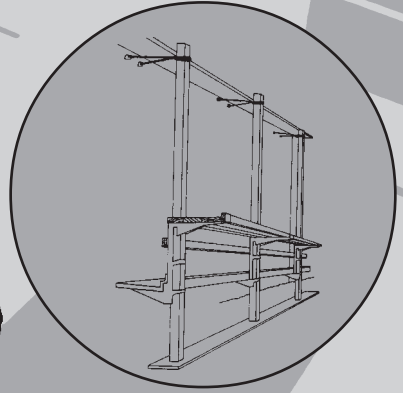

U.S. Department of Labor
Occupational Safety and Health Administration

OSHA 3146
1998(Revised)



This informational booklet is intended to provide a generic, non-exhaustive overview of a particular standards-related topic. This publication does not itself alter or determine compliance responsibilities, which are set forth in OSHA standards themselves, and the *Occupational Safety and Health Act*. Moreover, because interpretations and enforcement policy may change over time, for additional guidance on OSHA compliance requirements, the reader should consult current administrative interpretations and decisions by the Occupational Safety and Health Review Commission and the courts.

Material contained in this publication is in the public domain and may be reproduced, fully or partially, without the permission of the Federal Government. Source credit is requested but not required.

This information will be made available to sensory impaired individuals upon request.
Voice Phone: (202) 219-8615;
Telecommunications Device for the Deaf (TDD) message referral phone: 1-800-326-2577.

Fall Protection in Construction



U.S. Department of Labor
Alexis M. Herman, Secretary

Occupational Safety and Health Administration
Charles N. Jeffress, Assistant Secretary

OSHA 3146
1998 (Revised)

	Page
Why Does OSHA Have a Standard for Fall Protection?	1
What Does the Fall Protection Standard Cover?	2
What Are the Requirements of the Standard?	4
Controlled Access Zones	4
Excavations	6
Fall Protection Systems Criteria and Practices	6
Covers ..	6
Guardrail Systems	7
Personal Fall Arrest Systems	9
Positioning Device Systems	11
Safety Monitoring Systems	11
Safety Net Systems	12
Warning Line Systems	14
Formwork and Reinforcing Steel	15
Hoist Areas	15
Holes	15
Leading Edges	15
Overhand Bricklaying and Related Work	16
Precast Concrete Erection	16
Protection From Falling Objects	16
Canopies	17
Toeboards	17
Training	17
Residential Construction	18
Ramps, Runways, and Other Walkways	19
Roofing	19
Low-Slope Roofs	19
Steep Roofs	19
Wall Openings	19

	Page
What Other Help Can OSHA Provide?	20
Safety and Health Program Management Guidelines	20
State Programs	20
Free Onsite Consultation	21
Voluntary Protection Programs	21
Training and Education	22
Electronic Information	22
Emergencies	23
Glossary	24
Related OSHA Publications	27
States with Approved Plans	28
OSHA Consultation Project Directory	32
OSHA Area Offices	34
OSHA Regional Offices	37

In the construction industry in the U.S., falls are the leading cause of worker fatalities. Each year, on average, between 150 and 200 workers are killed and more than 100,000 are injured as a result of falls at construction sites. OSHA recognizes that accidents involving falls are generally complex events frequently involving a variety of factors. Consequently, the standard for fall protection deals with both the human and equipment-related issues in protecting workers from fall hazards. For example, employers and employees need to do the following:

- Where protection is required, select fall protection systems appropriate for given situations.
- Use proper construction and installation of safety systems.
- Supervise employees properly.
- Use safe work procedures.
- Train workers in the proper selection, use, and maintenance of fall protection systems.

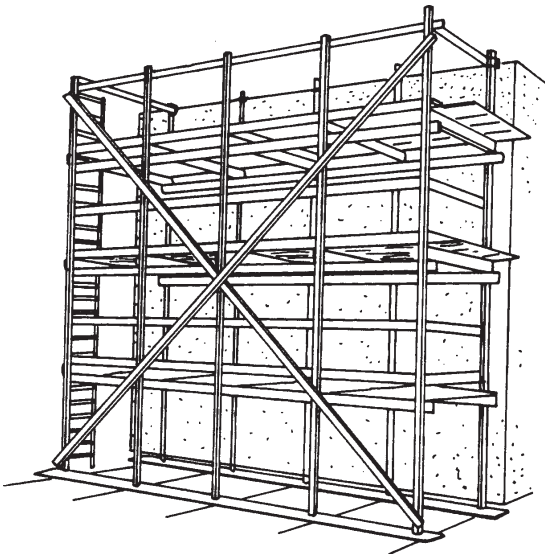

OSHA has revised its construction industry safety standards [Title 29 Code of Federal Regulations, Subpart M, Fall Protection, 1926.500(a), 1926.501, 1926.502, and 1926.503] and developed systems and procedures designed to prevent employees from falling off, onto, or through working levels and to protect employees from being struck by falling objects (*Federal Register*, August 9, 1994, pp. 40672-40753). The performance-oriented requirements make it easier for employers to provide the necessary protection.

The rule covers most construction workers except those inspecting, investigating, or assessing workplace conditions prior to the actual start of work or after all work has been completed.

The rule identifies areas or activities where fall protection is needed. These include, but are not limited to, ramps, runways, and other walkways, excavations, hoist areas, holes, formwork and reinforcing steel, leading edge work, unprotected sides and edges, overhand bricklaying and related work, roofing work, precast concrete erection, wall openings, residential construction, and other walking/working surfaces. The rule sets a uniform threshold height of 6 feet (1.8 meters), thereby providing consistent protection. This means that construction employers must protect their employees from fall hazards and falling objects whenever an affected employee is 6 feet (1.8 meters) or more above a lower level. Protection also must be provided for construction workers who are exposed to the hazard of falling into dangerous equipment.

Under the standard, employers are able to select fall protection measures compatible with the type of work being performed. Fall protection generally can be provided through the use of guardrail systems, safety net systems, personal fall arrest systems, positioning device systems, and warning line systems, among others.

The OSHA rule clarifies what an employer must do to provide fall protection for employees, such as identifying and evaluating fall hazards and providing specific training. Requirements to provide fall protection for workers on scaffolds and ladders and for workers engaged in steel erection of buildings are covered in other subparts of OSHA regulations.



The standard prescribes the duty to provide fall protection, sets the criteria and practices for fall protection systems, and requires training. It covers hazard assessment and fall protection and safety monitoring systems. Also addressed are controlled access zones, safety nets, and guardrail, personal fall arrest, warning line, and positioning device systems.

Under *29 CFR Subpart M, Fall Protection, 1926.501*, employers must assess the workplace to determine if the walking or working surfaces on which employees are to work have the strength and structural integrity to safely support workers. Employees are not permitted to work on those surfaces until it has been determined that the surfaces have the requisite strength and structural integrity to support the workers. Once employers have determined that the surface is safe for employees to work on, the employer must select one of the options listed for the work operation if a fall hazard is present.

For example, if an employee is exposed to falling 6 feet (1.8 meters) or more from an unprotected side or edge, the employer must select either a guardrail system, safety net system, or personal fall arrest system to protect the worker.

Similar requirements are prescribed for other fall hazards as follows:

Controlled Access Zones - 1926.502(g)

A controlled access zone is a work area designated and clearly marked in which certain types of work (such as overhand bricklaying) may take place without the use of conventional fall protection systems—guardrail, personal arrest or safety net—to protect the employees working in the zone.

Controlled access zones are used to keep out workers other than those authorized to enter work areas from which guardrails have been removed. Where there are no guardrails, masons are the only workers allowed in controlled access zones.

Controlled access zones, when created to limit entrance to areas where leading edge work and other operations are taking place, must be defined by a control line or by any other means that restrict access. Control lines shall consist of ropes, wires, tapes or equivalent materials, and supporting stanchions, and each must be:

- Flagged or otherwise clearly marked at not more than 6-foot (1.8 meters) intervals with high-visibility material.
- Rigged and supported in such a way that the lowest point (including sag) is not less than 39 inches (1 meter) from the walking/working surface and the highest point is not more than 45 inches (1.3 meters)—nor more than 50 inches (1.3 meters) when overhand bricklaying operations are being performed—from the walking/working surface.
- Strong enough to sustain stress of not less than 200 pounds (0.88 kiloNewtons). Control lines shall extend along the entire length of the unprotected or leading edge and shall be approximately parallel to the unprotected or leading edge.
- Control lines also must be connected on each side to a guardrail system or wall.

When control lines are used, they shall be erected not less than 6 feet (1.8 meters) nor more than 25 feet (7.6 meters) from the unprotected or leading edge, except when precast concrete members are being erected. In the latter case, the control line is to be erected not less than 6 feet (1.8 meters) nor more than 60 feet (18 meters) or half the length of the member being erected, whichever is less, from the leading edge.

Controlled access zones when used to determine access to areas where **overhand bricklaying** and **related work** are taking place are to be defined by a control line erected not less than 10 feet (3 meters) nor more than 15 feet (4.6 meters) from the working edge. Additional control lines must be erected at

each end to enclose the controlled access zone. Only employees engaged in overhand bricklaying or related work are permitted in the controlled access zones.

On floors and roofs where guardrail systems are not in place prior to the beginning of overhand bricklaying operations, controlled access zones must be enlarged as necessary to enclose all points of access, material handling areas, and storage areas.

On floors and roofs where guardrail systems are in place, but need to be removed to allow overhand bricklaying work or leading edge work to take place, only that portion of the guardrail necessary to accomplish that day's work shall be removed.

Excavations - 1926.501(b)(7)

Each employee at the edge of an excavation 6 feet (1.8 meters) or more deep shall be protected from falling by guardrail systems, fences, barricades, or covers. Where walkways are provided to permit employees to cross over excavations, guardrails are required on the walkway if the fall would be 6 feet (1.8 meters) or more to the lower level.

Fall Protection Systems Criteria and Practices

Covers - 1926.502(i)

Covers located in roadways and vehicular aisles must be able to support at least twice the maximum axle load of the largest vehicle to which the cover might be subjected. All other covers must be able to support at least twice the weight of employees, equipment, and materials that may be imposed on the cover at any one time. To prevent accidental displacement resulting from wind, equipment, or workers' activities, all covers must be secured. All covers shall be color coded or bear the markings "HOLE" or "COVER."

Guardrail Systems - 1926.501(502)(b)

If the employer chooses to use guardrail systems to protect workers from falls, the systems must meet the following criteria. Toprails and midrails of guardrail systems must be at least one-quarter inch (0.6 centimeters) nominal diameter or thickness to prevent cuts and lacerations. If wire rope is used for toprails, it must be flagged at not more than 6 feet intervals (1.8 meters) with high-visibility material. Steel and plastic banding cannot be used as toprails or midrails. Manila, plastic, or synthetic rope used for toprails or midrails must be inspected as frequently as necessary to ensure strength and stability.

The top edge height of toprails, or (equivalent) guardrails must be 42 inches (1.1 meters) plus or minus 3 inches (8 centimeters), above the walking/working level. When workers are using stilts, the top edge height of the top rail, or equivalent member, must be increased an amount equal to the height of the stilts.

Screens, midrails, mesh, intermediate vertical members, or equivalent intermediate structural members must be installed between the top edge of the guardrail system and the walking/working surface when there are no walls or parapet walls at least 21 inches (53 centimeters) high. When midrails are used, they must be installed at a height midway between the top edge of the guardrail system and the walking/working level. When screens and mesh are used, they must extend from the top rail to the walking/working level and along the entire opening between top rail supports. Intermediate members, such as balusters, when used between posts, shall not be more than 19 inches (48 centimeters) apart.

Other structural members, such as additional midrails and architectural panels, shall be installed so that there are no openings in the guardrail system more than 19 inches (48 centimeters).

The guardrail system must be capable of withstanding a force of at least 200 pounds (890 Newtons) applied within 2 inches of the top edge in any outward or downward direction. When the 200 pounds (890 Newtons) test is applied in a downward direction, the top edge of the guardrail must not deflect to a height less than 39 inches (1 meter) above the walking/working level.

Midrails, screens, mesh, intermediate vertical members, solid panels, and equivalent structural members shall be capable of withstanding a force of at least 150 pounds (666 Newtons) applied in any downward or outward direction at any point along the midrail or other member.

Guardrail systems shall be surfaced to protect workers from punctures or lacerations and to prevent clothing from snagging.

The ends of top rails and midrails must not overhang terminal posts, except where such an overhang does not constitute a projection hazard.

When guardrail systems are used at hoisting areas, a chain, gate or removable guardrail section must be placed across the access opening between guardrail sections when hoisting operations are not taking place.

At holes, guardrail systems must be set up on all unprotected sides or edges. When holes are used for the passage of materials, the hole shall have not more than two sides with removable guardrail sections. When the hole is not in use, it must be covered or provided with guardrails along all unprotected sides or edges.

If guardrail systems are used around holes that are used as access points (such as ladderways), gates must be used or the point of access must be offset to prevent accidental walking into the hole.

If guardrails are used at unprotected sides or edges of ramps and runways, they must be erected on each unprotected side or edge.

Personal Fall Arrest Systems - 1926.502(d)

These consist of an anchorage, connectors, and a body belt or body harness and may include a deceleration device, lifeline, or suitable combinations. If a personal fall arrest system is used for fall protection, it must do the following:

- Limit maximum arresting force on an employee to 900 pounds (4 kiloNewtons) when used with a body belt;
- Limit maximum arresting force on an employee to 1,800 pounds (8 kiloNewtons) when used with a body harness;
- Be rigged so that an employee can neither free fall more than 6 feet (1.8 meters) nor contact any lower level;
- Bring an employee to a complete stop and limit maximum deceleration distance an employee travels to 3.5 feet (1.07 meters); and
- Have sufficient strength to withstand twice the potential impact energy of an employee free falling a distance of 6 feet (1.8 meters) or the free fall distance permitted by the system, whichever is less.

The use of body belts for fall arrest is currently allowed, but effective January 1, 1998, the use of a body belt for fall arrest will be prohibited; however, the use of a body belt in a positioning device system is acceptable.

Personal fall arrest systems must be inspected prior to each use for wear damage, and other deterioration. Defective components must be removed from service. Dee-rings and snaphooks must have a minimum tensile strength of 5,000 pounds (22.2 kiloNewtons). Dee-rings and snaphooks shall be proof-tested to a minimum tensile load of 3,600 pounds (16 kiloNewtons) without cracking, breaking, or suffering permanent deformation.

Snaphooks shall be sized to be compatible with the member to which they will be connected, or shall be of a locking configuration.

Unless the snaphook is a locking type and designed for the following connections, they shall not be engaged (a) directly to webbing, rope, or wire rope; (b) to each other; (c) to a dee-ring to which another snaphook or other connector is attached; (d) to a horizontal lifeline; or (e) to any object incompatible in shape or dimension relative to the snaphook, thereby causing the connected object to depress the snaphook keeper and release unintentionally.

OSHA considers a hook to be compatible when the diameter of the dee-ring to which the snaphook is attached is greater than the inside length of the snaphook when measured from the bottom (hinged end) of the snaphook keeper to the inside curve of the top of the snaphook. Thus, no matter how the dee-ring is positioned or moved (rolls) with the snaphook attached, the dee-ring cannot touch the outside of the keeper, thus depressing it open. As of January 1, 1998, the use of nonlocking snaphooks will be prohibited.

On suspended scaffolds or similar work platforms with horizontal lifelines that may become vertical lifelines, the devices used to connect to a horizontal lifeline shall be capable of locking in both directions on the lifeline.

Horizontal lifelines shall be designed, installed, and used under the supervision of a qualified person, as part of a complete personal fall arrest system that maintains a safety factor of at least two. Lifelines shall be protected against being cut or abraded.

Self-retracting lifelines and lanyards that automatically limit free fall distance to 2 feet (0.61 meters) or less shall be capable of sustaining a minimum tensile load of 3,000 pounds (13.3 kiloNewtons) applied to the device with the lifeline or lanyard in the fully extended position.

Self-retracting lifelines and lanyards that do not limit free fall distance to 2 feet (0.61 meters) or less, ripstitch lanyards, and tearing and deforming lanyards shall be capable of sustain-

ing a minimum tensile load of 5,000 pounds (22.2 kiloNewtons) applied to the device with the lifeline or lanyard in the fully extended position.

Ropes and straps (webbing) used in lanyards, lifelines, and strength components of body belts and body harnesses shall be made of synthetic fibers.

Anchorage shall be designed, installed, and used under the supervision of a qualified person, as part of a complete personal fall arrest system that maintains a safety factor of at least two, i.e., capable of supporting at least twice the weight expected to be imposed upon it. Anchorages used to attach personal fall arrest systems shall be independent of any anchorage being used to support or suspend platforms and must be capable of supporting at least 5,000 pounds (22.2 kiloNewtons) per person attached.

Lanyards and vertical lifelines must have a minimum breaking strength of 5,000 pounds (22.2 kiloNewtons).

Positioning Device Systems - 1926.502(e)

These body belt or body harness systems are to be set up so that a worker can free fall no farther than 2 feet (0.6 meters). They shall be secured to an anchorage capable of supporting at least twice the potential impact load of an employee's fall or 3,000 pounds (13.3 kiloNewtons), whichever is greater. Requirements for snaphooks, dee-rings, and other connectors used with positioning device systems must meet the same criteria as those for personal fall arrest systems.

Safety Monitoring Systems - 1926.502(h)

When no other alternative fall protection has been implemented, the employer shall implement a safety monitoring system. Employers must appoint a competent person to

monitor the safety of workers and the employer shall ensure that the safety monitor:

- Is competent in the recognition of fall hazards,
- Is capable of warning workers of fall hazard dangers and in detecting unsafe work practices,
- Is operating on the same walking/working surfaces of the workers and can see them, and
- Is close enough to work operations to communicate orally with workers and has no other duties to distract from the monitoring function.

Mechanical equipment shall not be used or stored in areas where safety monitoring systems are being used to monitor employees engaged in roofing operations on low-sloped roofs.

No worker, other than one engaged in roofing work (on low-sloped roofs) or one covered by a fall protection plan, shall be allowed in an area where an employee is being protected by a safety monitoring system.

All workers in a controlled access zone shall be instructed to promptly comply with fall hazard warnings issued by safety monitors.

Safety Net Systems - 1926.502(c)

Safety nets must be installed as close as practicable under the walking/working surface on which employees are working and never more than 30 feet (9.1 meters) below such levels. Defective nets shall not be used. Safety nets shall be inspected at least once a week for wear, damage, and other deterioration. The maximum size of each safety net mesh opening shall not exceed 36 square inches (230 square centimeters) nor be longer than 6 inches (15 centimeters) on any side, and the openings, measured center-to-center, of mesh ropes or webbing, shall not exceed 6 inches (15 centimeters). All mesh crossings shall be

secured to prevent enlargement of the mesh opening. Each safety net or section shall have a border rope for webbing with a minimum breaking strength of 5,000 pounds (22.2 kiloNewtons). Connections between safety net panels shall be as strong as integral net components and be spaced no more than 6 inches (15 centimeters) apart.

Safety nets shall be installed with sufficient clearance underneath to prevent contact with the surface or structure below.

When nets are used on bridges, the potential fall area from the walking/working surface to the net shall be unobstructed.

Safety nets must extend outward from the outermost projection of the work surface as follows:

Vertical distance from working level to horizontal plane of net surface.	Minimum required horizontal distance of outer edge of net from edge of working surface.
Up to 5 feet (1.5 meters)	8 feet (2.4 meters)
More than 5 feet (1.5 meters) up to 10 feet (3 meters)	10 feet (3 meters)
More than 10 feet (3 meters)	13 feet (3.9 meters)

Safety nets shall be capable of absorbing an impact force of a drop test consisting of a 400-pound (180 kilograms) bag of sand 30 inches (76 centimeters) in diameter dropped from the highest walking/working surface at which workers are exposed, but not from less than 42 inches (1.1 meters) above that level.

Items that have fallen into safety nets including—but not restricted to, materials, scrap, equipment, and tools—must be removed as soon as possible and at least before the next work shift.

Warning Line Systems - 1926.502(f)

Warning line systems consist of ropes, wires, or chains, and supporting stanchions and are set up as follows:

- Flagged at not more than 6-foot (1.8 meters) intervals with high-visibility material.
- Rigged and supported so that the lowest point including sag is no less than 34 inches (0.9 meters) from the walking/working surface and its highest point is no more than 39 inches (1 meter) from the walking/working surface.
- Stanchions, after being rigged with warning lines, shall be capable of resisting, without tipping over, a force of at least 16 pounds (71 Newtons) applied horizontally against the stanchion, 30 inches (0.8 meters) above the walking/working surface, perpendicular to the warning line and in the direction of the floor, roof, or platform edge.
- The rope, wire, or chain shall have a minimum tensile strength of 500 pounds (2.22 kiloNewtons), and after being attached to the stanchions, must support without breaking the load applied to the stanchions as prescribed above.
- Shall be attached to each stanchion in such a way that pulling on one section of the line between stanchions will not result in slack being taken up in the adjacent section before the stanchion tips over.

Warning lines shall be erected around all sides of roof work areas. When mechanical equipment is being used, the warning line shall be erected not less than 6 feet (1.8 meters) from the roof edge parallel to the direction of mechanical equipment operation, and not less than 10 feet (3 meters) from the roof edge perpendicular to the direction of mechanical equipment operation.

When mechanical equipment is not being used, the warning line must be erected not less than 6 feet (1.8 meters) from the roof edge.

Formwork and Reinforcing Steel - 1926.501(b)(5)

For employees, while moving vertically and/or horizontally on the vertical face of rebar assemblies built in place, fall protection is not required when employees are moving. OSHA considers the multiple hand holds and foot holds on rebar assemblies as providing similar protection as that provided by a fixed ladder. Consequently, no fall protection is necessary while moving point to point for heights below 24 feet (7.3 meters). An employee must be provided with fall protection when climbing or otherwise moving at a height more than 24 feet (7.3 meters), the same as for fixed ladders.

Hoist Areas - 1926.501(b)(3)

Each employee in a hoist area shall be protected from falling 6 feet (1.8 meters) or more by guardrail systems or personal fall arrest systems. If guardrail systems (or chain gate or guardrail) or portions thereof must be removed to facilitate hoisting operations, as during the landing of materials, and a worker must lean through the access opening or out over the edge of the access opening to receive or guide equipment and materials, that employee must be protected by a personal fall arrest system.

Holes - 1926.501(b)(4)

Personal fall arrest systems, covers, or guardrail systems shall be erected around holes (including skylights) that are more than 6 feet (1.8 meters) above lower levels.

Leading Edges - 1926.501(b)(2)

Each employee who is constructing a leading edge 6 feet (1.8 meters) or more above lower levels shall be protected by guardrail systems, safety net systems, or personal fall arrest systems. If the employer can demonstrate that it is infeasible

or creates a greater hazard to implement these systems, he or she must develop and implement a fall protection plan that meets the requirements of 29 CFR 1926.502(k).

Overhand Bricklaying and Related Work - 1926.501(b)(9)

Each employee performing overhand bricklaying and related work 6 feet (1.8 meters) or more above lower levels shall be protected by guardrail systems, safety net systems, or personal fall arrest systems, or shall work in a controlled access zone. All employees reaching more than 10 inches (25 centimeters) below the level of a walking/working surface on which they are working shall be protected by a guardrail system, safety net system, or personal fall arrest system.

Precast Concrete Erection - 1926.501(b)(12)

Each employee who is 6 feet (1.8 meters) or more above lower levels while erecting precast concrete members and related operations such as grouting of precast concrete members shall be protected by guardrail systems, safety net systems, or personal fall arrest systems. Where the employer can demonstrate, however, that it is infeasible or creates a greater hazard to use those systems, the employer must develop and implement a fall protection plan that meets the requirements of 29 CFR 1926.502(k).

Protection from Falling Objects - 1926.502(j)

When guardrail systems are used to prevent materials from falling from one level to another, any openings must be small enough to prevent passage of potential falling objects. No materials or equipment except masonry and mortar shall be stored within 4 feet (1.2 meters) of working edges. Excess mortar, broken or scattered masonry units, and all other materials and debris shall be kept clear of the working area by removal at regular intervals.

During roofing work, materials and equipment shall not be stored within 6 feet (1.8 meters) of a roof edge unless guardrails are erected at the edge, and materials piled, grouped, or stacked near a roof edge must be stable and self-supporting.

Canopies - 1926.502(j)(8)

When used as protection from falling objects canopies must be strong enough to prevent collapse and to prevent penetration by any objects that may fall onto them.

Toeboards - 1926.502(j)(2), (3), and (4)

When toeboards are used as protection from falling objects, they must be erected along the edges of the overhead walking or working surface for a distance sufficient to protect persons working below. Toeboards shall be capable of withstanding a force of at least 50 pounds (222 Newtons) applied in any downward or outward direction at any point along the toeboard. Toeboards shall be a minimum of 3.5 inches (9 centimeters) tall from their top edge to the level of the walking/working surface, have no more than 0.25 inches (0.6 centimeters) clearance above the walking/working surface, and be solid or have openings no larger than 1 inch (2.5 centimeters) in size.

Where tools, equipment, or materials are piled higher than the top edge of a toeboard, paneling or screening must be erected from the walking/working surface or toeboard to the top of a guardrail system's top rail or midrail, for a distance sufficient to protect employees below.

Training - 1926.503

Employers must provide a training program that teaches employees who might be exposed to fall hazards how to recognize such hazards and how to minimize them. Employees must

be trained in the following areas: (a) the nature of fall hazards in the work area; (b) the correct procedures for erecting, maintaining, disassembling, and inspecting fall protection systems; (c) the use and operation of controlled access zones and guard-rail, personal fall arrest, safety net, warning line, and safety monitoring systems; (d) the role of each employee in the safety monitoring system when the system is in use; (e) the limitations on the use of mechanical equipment during the performance of roofing work on low-slope roofs; (f) the correct procedures for equipment and materials handling and storage and the erection of overhead protection; and, (g) employees' role in fall protection plans; and (h) the standards in this Subpart.

Employers must prepare a written certification that identifies the employee trained and the date of the training. The employer or trainer must sign the certification record. Retraining also must be provided when necessary.

Residential Construction - 1926.501(b)(13)

Fall protection requirements for residential construction mirror those of "Precast Concrete Erection." In addition, however, OSHA Instruction STD 3.1, "Interim Fall Protection Compliance Guidelines for Residential Construction" issued December 8, 1995, identifies certain tasks that may be performed without the use of conventional fall protection provided the employer follows all guidelines in Appendix E of Subpart M. OSHA's STD 3.1 relieves the residential homebuilder from the obligation to show "infeasibility or greater hazard" when electing to use alternative fall protection plans in lieu of conventional fall protection. OSHA directives are on the Internet World Wide Web at <http://www.osha.gov>. Also, if the guidelines in Appendix E are followed, the employer is not required to have a written fall protection plan as specified in 1926.502(k).

Ramps, Runways, and Other Walkways - 1926.501(b)(6)

Each employee using ramps, runways, and other walkways shall be protected by guardrail systems against falling 6 feet (1.8 meters) or more.

Roofing

Low-Slope Roofs - 1926.501(b)(10)

Each employee engaged in roofing activities on low-slope roofs with unprotected sides and edges 6 feet (1.8 meters) or more above lower levels shall be protected from falling by guardrail systems, safety net systems, personal fall arrest systems or a combination of a warning line system and guardrail system, warning line system and safety net system, warning line system and personal fall arrest system, or warning line system and safety monitoring system. On roofs 50 feet (15.25 meters) or less in width, the use of a safety monitoring system without a warning line system is permitted.

Steep Roofs - 1926.501(b)(11)

Each employee on a steep roof with unprotected sides and edges 6 feet (1.8 meters) or more above lower levels shall be protected by either guardrail systems with toeboards, a safety net system, or a personal fall arrest system.

Wall Openings - 1926.501(b)(14)

Each employee working on, at, above, or near wall openings (including those with chutes attached) where the outside bottom edge of the wall opening is 6 feet (1.8 meters) or more above lower levels and the inside bottom edge of the wall opening is less than 39 inches (1.0 meter) above the walking/working surface must be protected from falling by the use of either a guardrail system, a safety net system, or a personal fall arrest system.

Safety and Health Program Management Guidelines

Effective management of worker safety and health protection is a decisive factor in reducing the extent and severity of work-related injuries and illnesses and their related costs. To assist employers and employees in developing effective safety and health programs, OSHA published recommended *Safety and Health Program Management Guidelines* in the January 26, 1989 [54 *Federal Register* (18): 3908-3916]. These voluntary guidelines apply to all places of employment covered by OSHA.

The guidelines identify four general elements that are critical to the development of a successful safety and health management program:

- Management commitment and employee involvement;
- Worksite analysis;
- Hazard prevention and control; and
- Safety and health training.

The guidelines recommend specific actions under each of these general elements. A single free copy of the guidelines can be obtained from the OSHA Publications Office, U.S. Department of Labor, 200 Constitution Avenue, N.W., Room N3101, Washington DC 20210 by sending a self-addressed mail label with your request.

State Programs

The *Occupational Safety and Health Act of 1970* encourages states to develop and operate their own job safety and health plans. The States administering occupational safety and health programs through plans approved under section 18(b) of the Act, must adopt standards and enforce requirements that are “at least as effective” as federal requirements. There are currently 25 state plans: 23 cover the private and public (state and local governments) sectors and 2 cover the public sector only.

For more information on OSHA-approved state plans, see the list of states with approved plans at the end of this publication.

Free Onsite Consultation

Free, onsite safety and health consultation services are available to employers in all states who want help in establishing and maintaining a safe and healthful workplace. The service is largely funded by OSHA. Primarily developed for smaller employers with more hazardous operations, the consultation service is delivered by state governments employing professional safety consultants and health consultants. Comprehensive assistance includes an appraisal of all mechanical systems, physical work practices, and environmental hazards of the workplace and all aspects of the employer's present job safety and health program. This program is completely separate from OSHA inspections. No penalties are proposed or citations issued for any safety and health problems identified by the consultants. Also, the service is confidential.

For more information concerning consultation services, see the list of consultation projects at the end of this publication.

Voluntary Protection Programs (VPP)

OSHA's Voluntary Protection Programs are designed to recognize and promote effective safety and health program management. In the VPP, management, labor, and OSHA establish cooperative relationships at workplaces that have implemented strong programs.

Sites approved for VPPs, Star, Merit, and Demonstration programs have met, and must continue to meet, rigorous participation standards. Benefits of VPP participation include improved employee motivation to work safely, leading to better quality and productivity; lost-workday case rates that generally are 60 percent to 80 percent below industry averages; reduced

workers' compensation and other injury- and illness-related costs; positive community recognition and interaction; further improvement and revitalization of already good safety and health programs; and partnership with OSHA.

For information about the VPP, contact the VPP Manager in your OSHA Regional Office, listed at the end of this publication.

Training and Education

OSHA's area offices offer a variety of informational services, such as publications, audiovisual aids, technical advice, and speakers for special engagements. OSHA's Training Institute in Des Plaines, IL, provides basic and advanced courses in safety and health for federal and state compliance officers, state consultants, federal agency personnel, and private sector employers, employees, and their representatives.

OSHA also provides funds to nonprofit organizations, through grants, to conduct workplace training and education in subjects where OSHA believes there is a lack of workplace training. Grants are awarded annually. Grant recipients are expected to contribute 20 percent of the total grant cost.

For more information on grants, training, and education, contact the OSHA Training Institute, Office of Training and Education, 1555 Times Drive, Des Plaines, IL 60018, (847) 297-4810.

Electronic Assistance

Internet—OSHA standards, interpretations, directives, technical advisors, compliance assistance, and additional information are now on the World Wide Web at <http://www.osha.gov/>.

CD-ROM—A wide variety of OSHA materials including standards, interpretations, directives, and more can be purchased on CD-ROM from the Government Printing Office.

To order, write to the Superintendent of Documents, P.O. Box 371954, Pittsburgh PA 15250-7954. Specify *OSHA Regulations, Documents and Technical Information on CD-ROM, (ORDT)*, S/N729-1300000-5. The price is \$38 per year (\$47.50 foreign); single copy \$15.00 (\$18.75 foreign).

Emergencies

For life-threatening situations, call (800) 321-OSHA. Complaints will go immediately to the nearest OSHA area or state office for help.

For further information on any OSHA program, contact your nearest OSHA area or regional office listed at the end of this publication.



Anchorage — A secure point of attachment for lifelines, lanyards or deceleration devices.

Body belt — A strap with means both for securing it about the waist and for attaching it to a lanyard, lifeline, or deceleration device.

Body harness — Straps that may be secured about the person in a manner that distributes the fall-arrest forces over at least the thighs, pelvis, waist, chest, and shoulders with a means for attaching the harness to other components of a personal fall arrest system.

Connector — A device that is used to couple (connect) parts of a personal fall arrest system or positioning device system together.

Controlled access zone — A work area designated and clearly marked in which certain types of work (such as over-hand bricklaying) may take place without the use of conventional fall protection systems—guardrail, personal arrest or safety net—to protect the employees working in the zone.

Deceleration device — Any mechanism—such as rope, grab, ripstitch lanyard, specially-woven lanyard, tearing or deforming lanyards, automatic self-retracting lifelines/lanyards—which serves to dissipate a substantial amount of energy during a fall arrest, or otherwise limits the energy imposed on an employee during fall arrest.

Deceleration distance — The additional vertical distance a falling person travels, excluding lifeline elongation and free fall distance, before stopping, from the point at which a deceleration device begins to operate.

Guardrail system — A barrier erected to prevent employees from falling to lower levels.

Hole — A void or gap 2 inches (5.1 centimeters) or more in the least dimension in a floor, roof, or other walking/working surface.

Lanyard — A flexible line of rope, wire rope, or strap that generally has a connector at each end for connecting the body belt or body harness to a deceleration device, lifeline, or anchorage.

Leading edge — The edge of a floor, roof, or formwork for a floor or other walking/working surface (such as the deck) which changes location as additional floor, roof, decking, or formwork sections are placed, formed or constructed.

Lifeline — A component consisting of a flexible line for connection to an anchorage at one end to hang vertically (vertical lifeline), or for connection to anchorages at both ends to stretch horizontally (horizontal lifeline), and that serves as a means for connecting other components of a personal fall arrest system to the anchorage.

Low-slope roof — A roof having a slope less than or equal to 4 in 12 (vertical to horizontal).

Opening — A gap or void 30 inches (76 centimeters) or more high and 18 inches (46 centimeters) or more wide, in a wall or partition, through which employees can fall to a lower level.

Personal fall arrest system — A system including but not limited to an anchorage, connectors, and a body belt or body harness used to arrest an employee in a fall from a working level. As of January 1, 1998, the use of a body belt for fall arrest is prohibited.

Positioning device system — A body belt or body harness system rigged to allow an employee to be supported on an elevated vertical surface, such as a wall, and work with both hands free while leaning backwards.

Rope grab — A deceleration device that travels on a lifeline and automatically, by friction, engages the lifeline and locks to arrest a fall.

Safety-monitoring system — A safety system in which a competent person is responsible for recognizing and warning employees of fall hazards.

Self-retracting lifeline/lanyard — A deceleration device containing a drum-wound line which can be slowly extracted from, or retracted onto, the drum under minimal tension during normal employee movement and which, after onset of a fall, automatically locks the drum and arrests the fall.

Snaphook — A connector consisting of a hook-shaped member with a normally closed keeper, or similar arrangement, which may be opened to permit the hook to receive an object and, when released automatically closes to retain the object.

Steep roof — A roof having a slope greater than 4 in 12 (vertical to horizontal).

Toeboard — A low protective barrier that prevents material and equipment from falling to lower levels and which protects personnel from falling.

Unprotected sides and edges — Any side or edge (except at entrances to points of access) of a walking/working surface (e.g., floor, roof, ramp, or runway) where there is no wall or guardrail system at least 39 inches (1 meter) high.

Walking/working surface — Any surface, whether horizontal or vertical, on which an employee walks or works, including but not limited to floors, roofs, ramps, bridges, runways, formwork, and concrete reinforcing steel. Does not include ladders, vehicles, or trailers on which employees must be located to perform their work duties.

Warning line system — A barrier erected on a roof to warn employees that they are approaching an unprotected roof side or edge and which designates an area in which roofing work may take place without the use of guardrail, body belt, or safety net systems to protect employees in the area.

Single, free copies of the following publications can be obtained from the U.S. Department of Labor, OSHA/OICA Publications, P.O. Box 37535, Washington, DC 20013-7535. Send a self-addressed mailing label with your request.

All About OSHA — OSHA 2056

Employee Workplace Rights — OSHA 3021

Ground Fault Protection on Construction Sites — OSHA 3007

Lead in Construction — OSHA 3142

Occupational Exposure to Cadmium in the Construction Industry — OSHA 3139

OSHA Publications and Audiovisual Programs — OSHA 2019

Personal Protective Equipment — OSHA 3077

Sling Safety — OSHA 3072

The following publications are available from the Superintendent of Documents, U.S. Government Printing Office, Washington, DC 20402 (202) 512-1800. Include GPO Order No. and make checks payable to Superintendent of Documents.

Construction Industry Digest – OSHA 2202
Order No. 029-016-00151-4; cost \$2.25.

Controlling Electrical Hazards – OSHA 3075
Order No. 029-016-00126-3; cost \$1.00.

Ergonomics: The Study of Work – OSHA 3125
Order No. 029-016-00124-7; cost \$1.00.

Hand and Power Tools – OSHA 3080
Order No. 029-016-00143-3; cost \$1.00.

Job Hazard Analysis – OSHA 3071
Order No. 029-016-00142-5; cost \$1.00.

Commissioner

Alaska Department of Labor
1111 West 8th Street
Room 306
Juneau, AK 99801
(907) 465-2700

Director

Industrial Commission
of Arizona
800 W. Washington
Phoenix, AZ 85007
(602) 542-5795

Director

California Department
of Industrial Relations
45 Fremont Street
San Francisco, CA 94105
(415) 972-8835

Commissioner

Connecticut Department
of Labor
200 Folly Brook Boulevard
Wethersfield, CT 06109
(203) 566-5123

Director

Hawaii Department of Labor
and Industrial Relations
830 Punchbowl Street
Honolulu, HI 96813
(808) 586-8844

Commissioner

Indiana Department of Labor
State Office Building
402 West Washington Street
Room W195
Indianapolis, IN 46204
(317) 232-2378

Commissioner

Iowa Division of Labor
Services
1000 E. Grand Avenue
Des Moines, IA 50319
(515) 281-3447

Secretary

Kentucky Labor Cabinet
1049 U.S. Highway, 127
South Suite 2
Frankfort, KY 40601
(502) 564-3070

Commissioner

Maryland Division of Labor
and Industry
Department of Licensing
and Regulation
1100 North Eutaw St.
Room 613
Baltimore, MD 21202-2206
(410) 767-2215

Director

Michigan Department
of Consumer
and Industry Services
4th Floor, Law Building
P.O. Box 30004
Lansing, MI 48909
(517) 373-7230

Commissioner

Minnesota Department
of Labor and Industry
443 Lafayette Road
St. Paul, MN 55155
(612) 296-2342

Director

Nevada Division
of Industrial Relations
400 West King Street
Carson City, NV 89710
(702) 687-3032

Secretary

New Mexico Environment
Department
1190 St. Francis Drive
P.O. Box 26110
Santa Fe, NM 87502
(505) 827-2850

Commissioner

New York Department
of Labor
W. Averell Harriman State
Office Building - 12
Room 500
Albany, NY 12240
(518) 457-2741

Commissioner

North Carolina Department
of Labor
319 Chapanoke Road
Raleigh, NC 27603
(919) 662-4585

Administrator

Department of Consumer
and Business Services
Occupational Safety
and Health
Division (OR-OSHA)
350 Winter Street, N.E.
Room 430
Salem, OR 97310-3220
(503) 378-3272

Secretary

Puerto Rico Department
of Labor and Human
Resources
Prudencio Rivera Martinez
Building
505 Munoz Rivera Avenue
Hato Rey, PR 00918
(809) 754-2119

Commissioner

South Carolina Department
of Labor, Licensing,
and Regulation
Koger Office Park,
Kingstree Bldg.
110 Centerview Drive
P.O. Box 11329
Columbia, SC 29216
(803) 896-4300

Commissioner

Tennessee Department
of Labor
Attn: Robert Taylor
710 James Robertson
Parkway
Nashville, TN 37243-0659
(615) 741-2582

Commissioner

Industrial Commission
of Utah
160 East 300 South,
3rd Floor
P.O. Box 146650
Salt Lake City, UT 84114-
6650
(801) 530-6898

Commissioner

Vermont Department of Labor
and Industry
National Life Building -
Drawer 20
120 State Street
Montpelier, VT 05620
(802) 828-2288

Commissioner

Virgin Islands Department
of Labor
2131 Hospital Street, Box 890
Christiansted
St. Croix, VI 00820-4666
(809) 773-1994

Commissioner

Virginia Department of Labor
and Industry
Powers-Taylor Building
13 South 13th Street
Richmond, VA 23219
(804) 786-2377

Director

Washington Department
of Labor and Industries
General Administration
Building
P.O. Box 44001
Olympia, WA 98504-4001
(360) 902-4200

Administrator

Workers' Safety
and Compensation Division
(WSC)

Wyoming Department
of Employment
Herschler Building
2nd Floor East
122 West 25th Street
Cheyenne, WY 82002
(307) 777-7786

State	Telephone
Alabama	(205) 348-7136
Alaska	(907) 269-4957
Arizona	(602) 542-5795
Arkansas	(501) 682-4522
California	(415) 972-8515
Colorado	(970) 491-6151
Connecticut	(860) 566-4550
Delaware	(302) 761-8219
District of Columbia	(202) 576-6339
Florida	(904) 488-3044
Georgia	(404) 894-2643
Guam	011(671) 475-0136
Hawaii	(808) 586-9100
Idaho	(208) 385-3283
Illinois	(312) 814-2337
Indiana	(317) 232-2688
Iowa	(515) 965-7162
Kansas	(913) 296-7476
Kentucky	(502) 564-6895
Louisiana	(504) 342-9601
Maine	(207) 624-6460
Maryland	(410) 333-4970
Massachusetts	(617) 727-3982
Michigan	(517) 332-1817 (H)
.....	(517) 322-1809 (S)
Minnesota	(612) 297-2393
Mississippi	(601) 987-3981
Missouri	(573) 751-3403
Montana	(406) 444-6418
Nebraska	(402) 471-4717
Nevada	(702) 486-5016
New Hampshire	(603) 271-2024
New Jersey	(609) 292-2424
New Mexico	(505) 827-4230

New York	(518) 457-2481
North Carolina	(919) 662-4644
North Dakota	(701) 328-5188
Ohio	(614) 644-2246
Oklahoma	(405) 528-1500
Oregon	(503) 378-3272
Pennsylvania	(412) 357-2561
Puerto Rico	(787) 754-2188
Rhode Island	(401) 277-2438
South Carolina	(803) 896-4300
South Dakota	(605) 688-4101
Tennessee	(615) 741-7036
Texas	(512) 440-3809
Utah	(801) 530-7606
Vermont	(802) 828-2765
Virginia	(804) 786-6359
Virgin Islands	(809) 772-1315
Washington	(360) 902-5638
West Virginia	(304) 558-7890
Wisconsin	(608) 266-8579 (H)
.....	(414) 521-5063 (S)
Wyoming	(307) 777-7786

(H) - Health

(S) - Safety

Area	Telephone
Albany, NY	(518) 464-4338
Albuquerque, NM	(505) 248-5302
Allentown, PA	(610) 776-0592
Anchorage, AK	(907) 271-5152
Appleton, WI	(414) 734-4521
Austin, TX	(512) 916-5783
Avenel, NJ	(908) 750-3270
Baltimore, MD	(410) 962-2840
Bangor, ME	(207) 941-8177
Baton Rouge, LA	(504) 389-0474
Bayside, NY	(718) 279-9060
Bellevue, WA	(206) 553-7520
Billings, MT	(406) 247-7494
Birmingham, AL	(205) 731-1534
Bismarck, ND	(701) 250-4521
Boise, ID	(208) 334-1867
Bowmansville, NY	(716) 684-3891
Braintree, MA	(617) 565-6924
Bridgeport, CT	(203) 579-5581
Calumet City, IL	(708) 891-3800
Carson City, NV	(702) 885-6963
Charleston, WV	(304) 347-5937
Cincinnati, OH	(513) 841-4132
Cleveland, OH	(216) 522-3818
Columbia, SC	(803) 765-5904
Columbus, OH	(614) 469-5582
Concord, NH	(603) 225-1629
Corpus Christi, TX	(512) 888-3420
Dallas, TX	(214) 320-2400
Denver, CO	(303) 844-5285
Des Plaines, IL	(847) 803-4800
Des Moines, IA	(515) 284-4794

Area	Telephone
Englewood, CO	(303) 843-4500
Erie, PA	(814) 833-5758
Fort Lauderdale, FL	(954) 424-0242
Fort Worth, TX	(817) 428-2470
Frankfort, KY	(502) 227-7024
Harrisburg, PA	(717) 782-3902
Hartford, CT	(860) 240-3152
Hasbrouck Heights, NJ	(201) 288-1700
Guaynabo, PR	(787) 277-1560
Honolulu, HI	(808) 541-2685
Houston, TX	(281) 286-0583
Houston, TX	(281) 591-2438
Indianapolis, IN	(317) 226-7290
Jackson, MS	(601) 965-4606
Jacksonville, FL	(904) 232-2895
Kansas City, MO	(816) 483-9531
Lansing, MI	(517) 377-1892
Little Rock, AR	(501) 324-6291
Lubbock, TX	(806) 472-7681
Madison, WI	(608) 264-5388
Marlton, NJ	(609) 757-5181
Methuen, MA	(617) 565-8110
Milwaukee, WI	(414) 297-3315
Minneapolis, MN	(612) 348-1994
Mobile, AL	(334) 441-6131
Nashville, TN	(615) 781-5423
New York, NY	(212) 466-2482
Norfolk, VA	(804) 441-3820
North Aurora, IL	(630) 896-8700
Oklahoma City, OK	(405) 231-5351
Omaha, NE	(402) 221-3182
Parsippany, NJ	(201) 263-1003
Peoria, IL	(309) 671-7033

Area	Telephone
Philadelphia, PA	(215) 597-4955
Phoenix, AZ	(602) 640-2007
Pittsburgh, PA	(412) 644-2903
Portland, OR	(503) 326-2251
Providence, RI	(401) 528-4669
Raleigh, NC	(919) 856-4770
Salt Lake City, UT	(801) 524-5080
Sacramento, CA	(916) 566-7470
San Diego, CA	(619) 557-2909
San Francisco, CA	(415) 744-7120
Savannah, GA	(912) 652-4393
Smyrna, GA	(404) 984-8700
Springfield, MA	(413) 785-0123
St. Louis, MO	(314) 425-4249
North Syracuse, NY	(315) 451-0808
Tampa, FL	(813) 626-1177
Tarrytown, NY	(914) 524-7510
Toledo, OH	(419) 259-7542
Tucker, GA	(404) 493-6644
Westbury, NY	(516) 334-3344
Wichita, KS.....	(316) 269-6644
Wilkes-Barre, PA	(717) 826-6538
Wilmington, DE	(302) 573-6115

Region I

(CT,* MA, ME, NH, RI, VT*)
JKF Federal Building
Room E-340
Boston, MA 02203
Telephone: (617) 565-9860

Region II

(NJ, NY,* PR,* VI*)
201 Varick Street
Room 670
New York, NY 10014
Telephone: (212) 337-2378

Region III

(DC, DE, MD,* PA, VA,* WV)
Gateway Building, Suite 2100
3535 Market Street
Philadelphia, PA 19104
Telephone: (215) 596-1201

Region IV

(AL, FL, GA, KY,* MS, NC,
SC,* TN*)
Atlanta Federal Center
61 Forsyth Street, SW,
Room 6T50
Atlanta, GA 30303
Telephone: (404) 562-2300

Region V

(IL, IN,* MI,* MN,* OH, WI)
230 South Dearborn Street
Room 3244
Chicago, IL 60604
Telephone: (312) 353-2220

Region VI

(AR, LA, NM,* OK, TX)
525 Griffin Street
Room 602
Dallas, TX 75202
Telephone: (214) 767-4731

Region VII

(IA,* KS, MO, NE)
City Center Square
1100 Main Street, Suite 800
Kansas City, MO 64105
Telephone: (816) 426-5861

Region VIII

(CO, MT, ND, SD, UT,* WY*)
1999 Broadway, Suite 1690
Denver, CO 80202-5716
Telephone: (303) 844-1600

Region IX

(American Samoa, AZ,* CA,*
Guam, HI,* NV,* Trust
Territories of the Pacific)
71 Stevenson Street
Room 420
San Francisco, CA 94105
Telephone: (415) 975-4310

Region X

(AK,* ID, OR,* WA*)
1111 Third Avenue
Suite 715
Seattle, WA 98101-3212
Telephone: (206) 553-5930

*These states and territories operate their own OSHA-approved job safety and health programs (Connecticut and New York plans cover public employees only). States with approved programs must have a standard that is identical to, or at least as effective, as the federal standard.