

Remnant Raising and VSO Clausal Architecture

*A Case Study of
San Lucas Quiaviní Zapotec*

*by
Felicia Lee*



Studies in Natural Language & Linguistic Theory

REMNANT RAISING AND VSO CLAUSAL ARCHITECTURE

Studies in Natural Language and Linguistic Theory

VOLUME 66

Managing Editors

Marcel den Dikken, *City University of New York*
Liliane Haegeman, *University of Lille*
Joan Maling, *Brandeis University*

Editorial Board

Guglielmo Cinque, *University of Venice*
Carol Georgopoulos, *University of Utah*
Jane Grimshaw, *Rutgers University*
Michael Kenstowicz, *Massachusetts Institute of Technology*
Hilda Koopman, *University of California, Los Angeles*
Howard Lasnik, *University of Connecticut at Storrs*
Alec Marantz, *Massachusetts Institute of Technology*
John J. McCarthy, *University of Massachusetts, Amherst*
Ian Roberts, *University of Cambridge*

The titles published in this series are listed at the end of this volume.

REMNANT RAISING AND VSO CLAUSAL ARCHITECTURE

A Case Study of San Lucas Quiaviní Zapotec

by

FELICIA LEE

*University of British Columbia,
BC, Canada*

 Springer

A C.I.P. Catalogue record for this book is available from the Library of Congress.

ISBN-10 1-4020-4300-7 (HB)
ISBN-13 978-1-4020-4300-0 (HB)
ISBN-10 1-4020-4308-2 (e-book)
ISBN-13 978-1-4020-4308-6 (e-book)

Published by Springer,
P.O. Box 17, 3300 AA Dordrecht, The Netherlands.

www.springer.com

Printed on acid-free paper

All Rights Reserved
© 2006 Springer

No part of this work may be reproduced, stored in a retrieval system, or transmitted in any form or by any means, electronic, mechanical, photocopying, microfilming, recording or otherwise, without written permission from the Publisher, with the exception of any material supplied specifically for the purpose of being entered and executed on a computer system, for exclusive use by the purchaser of the work.

Printed in the Netherlands.

Contents

Foreword	vii
Preface	xi
1. An Introduction to San Lucas Quiavini Zapotec	1
2. Background and Theoretical Assumptions	29
3. The Syntax of Verb Raising in SLQZ: Arguments for VP Raising	49
4. Further Consequences of VP-Remnant Movement: Some Common Negation Structures in SLQZ	107
5. More on the Structure of the Left Periphery: The Syntax of Questions	165
6. The Interaction of Tense and Aspect in San Lucas Quiavini Zapotec	199
References	269

Preface

I am deeply indebted to the following individuals for their intellectual, financial, and moral support:

Pamela Munro first introduced me to San Lucas Quiaviní Zapotec during her own pioneering research on the language, and introduced me to the joys of linguistic fieldwork. She has been a great mentor, role model, and friend. My Los Angeles-based language consultants, Rodrigo Garcia, Paco Lopez, and Felipe Lopez have been the most thoughtful, helpful, and generous consultants one could hope for, and I am deeply indebted to them. I also owe a debt of gratitude to the people of San Lucas Quiaviní for their hospitality, patience, and helpfulness during my visits to their town.

This current work grew out of my UCLA dissertation, and I am grateful to Hilda Koopman and Tim Stowell for helping me through the early stages of my syntactic theorizing. Aaron Broadwell, Andrew Carnie, Henry Davis, Rose-Marie Déchaine, Richard Kayne, Lisa Matthewson, and Martina Wiltschko also provided useful comments and questions during the development of this work. Lisa was also kind enough to fund some of my fieldwork through a grant of hers, for which I am also grateful.

Further funding for this work comes from a University of British Columbia Hampton grant on first-language acquisition in SLQZ held by myself and Joseph Stemberger. I am grateful to Joe and our two graduate research assistants (Diana Gibrael and Mario Chavez Peon) for sharing my interest in SLQZ. Their insights on SLQZ, mostly in the realm of phonology, morphophonemics, and acquisition, have been both stimulating and humbling to me: they remind me of how much more work there still is to be done.

Thanks are also due to Bryan Gick, Chris Golston, Paivi Koskinen, Kimary Shahin, and their respective spouses and families: they provided me with friendship, entertainment, and both linguistic and non-linguistic advice, all useful and accurate.

My parents, Fred and Margaret Lee, and sisters (Serena, Pamela, and Sondra) have always stood by me, and will always have my gratitude.

Finally, I owe my thanks to Glenn Price, for everything else I could want in life.

Foreword

The goals of this book are twofold: first, to document some of the basic syntactic structures of SLQZ, a little-examined indigenous language of Mexico; and second, to explore the theoretical implications of SLQZ syntactic structure for other VSO languages. A major challenge posed by SLQZ is the large number of syntactic contexts, such as negation and adverbial clitic placement, in which verbs and XPs such as prepositional phrases and DPs may appear interchangeably. The existence of such structures raises serious questions about the generally held assumption that verb movement for tense and agreement checking is invariably head-movement.

I argue instead that verbal movement in SLQZ is actually VP-remnant movement, rather than head-movement: this allows verbs and other constituents to be treated uniformly in the contexts in which they both may appear. I also show that such an analysis can be motivated theoretically by Kayne's (1994) Antisymmetry constraints. I will show that not only do the highly constrained rules on possible movement and base-generated structure account for the complex morphological and syntactic structures of SLQZ, but potentially other, unrelated, VSO languages as well.

Chapter 2 presents the theoretical background to be assumed in the rest of the work. Here, Kayne's work on antisymmetry will be introduced, and some of its possible consequences laid out. Chapter 2 will also provide a brief outline of previous research on the derivation of VSO word order across a range of languages. In this section of the chapter, I present evidence from SLQZ showing that these previous analyses cannot account for the morphological and word order constraints of SLQZ.

Chapter 3 presents the central thesis of this work: if Kayne's principles of antisymmetry are to be maintained, it must be assumed that VSO word order in SLQZ is derived by movement of a VP-remnant, rather than a verbal head, to clause-initial position. This proposal is supported by both morphological and syntactic data: first, I show that there is no way to derive the ordering of verbal morphemes in SLQZ verbal complexes through head-movement without assuming a base structure radically different from any attested in the literature; second, I show that SLQZ verbs and full

phrasal projections such as DPs and PPs participate interchangeably in a number of syntactic constructions. The fact that SLQZ verbs behave like XPs in syntactic operations supports the morphological evidence against their head status. I also briefly outline evidence that VP-remnant-movement may also account for VSO word order in a number of other, unrelated languages.

In Chapter 4, I show how the VP-raising analysis accounts for three common SLQZ negation constructions: clausal negation, constituent negation, and existential negation. I will also show that differences between these negation structures can be used as diagnostics to determine the ordering of left periphery functional projections, such as focus, and topic projections, in SLQZ. Furthermore, constraints on the interaction of negation structures with other constructions, such as questions and relative clause formation, also reveal additional antisymmetry-driven constraints on movement and structure, which will be described in detail.

Chapter 5 builds upon the analysis of functional projections developed in Chapter 4. It examines the syntax and semantics of question formation in SLQZ, which reveal additional information about the interaction of left periphery projections (such as focus, topic, and mood) in syntactic constructions and in the expression of different information structures. Much of this information comes from the examination of yes/no questions: SLQZ employs three distinct yes/no question markers, which differ both in their syntactic features and their discourse uses. WH-questions in SLQZ also reveal important information about the syntax of questions, and challenge some commonly held ideas about the correlation between wh-movement and syntactic focus movement: while it has been argued for a range of languages that wh-movement and focus movement target the same projection, SLQZ reveals a number of contexts in which they may co-occur in the same clause. This suggests that wh- and focus target different projections: the numerous contexts in SLQZ and other languages in which they appear to compete for the same position are due to the semantic requirements of wh-words: they encode focus as well as interrogative features, which in most cases are checked by movement of the word through focus.

Chapter 6 shows both syntactic and interpretive evidence for the presence of syntactic tense in SLQZ. While the Zapotec languages have been traditionally thought to lack syntactic tense and be purely aspect marking, I show that some of SLQZ's aspect markers should actually be considered tense markers that also encode aspect. Evidence for this comes from the different possible interpretations of these markers in different syntactic contexts, such as differences in possible interpretation between fronted and

in situ clausal complements of verbs with certain tense/aspect markers. Furthermore, the behavior of these aspect markers in different syntactic configurations supports recent proposals that tense is scope-sensitive, and that certain morphological tense markers should be treated as polarity items sensitive to the presence of tense heads, rather than heads of tense projections themselves. This chapter also shows how these proposals are implemented syntactically, and that their syntax is consistent with the VP-raising analysis previously outlined.

1 An Introduction to San Lucas Quiaviní Zapotec

1.1 Overview

This chapter presents a brief overview of the geneological, geographical, and ethnological background of SLQZ and its speakers, as well as a brief descriptive survey of the basic features of SLQZ phonology, morphology, and grammar. No theoretical explanation is attempted here; rather, this chapter aims to provide a basic overview of some of the data that will be accounted for in later chapters. This chapter gives special attention to the distribution and interpretation of SLQZ aspect markers. These markers, as will be shown below, also encode information about tense and mood. This chapter will also introduce some of the basic technical terminology and assumptions about SLQZ syntax that I assume in the rest of this work.

Much of this terminology I adopt, as well as a large proportion of the basic information described here, was first observed and documented in the San Lucas Quiaviní Zapotec dictionary (Munro, Lopez, et al 1999) (hereafter referred to as ML).¹ Many of the examples below come directly from this work, and will be cited as such. Unmarked examples given in this and following chapters come from my own fieldnotes or those collected in the SLQZ field methods course given at UCLA in fall 1994 and winter 1995.

1.2 SLQZ: The Language and Its Speakers

SLQZ belongs to the Otomanguean stock, which comprises 174 diverse languages spoken over much of Mexico. It belongs to the Zapotecan

¹ Munro, Pamela, and Felipe H. Lopez (with Michael R. Gallant, Rodrigo Garcia and Olivia V.Méndez) (1999) *Dicyonaary X:tè'n Dii'zh Sah Sann Luu'c: San Lucas Quiaviní Zapotec Dictionary. Diccionario Zapoteco de San Lucas Quiaviní*. Chicano Studies Research Center Publications,, UCLA

group of languages, which itself is divided into two families: Zapotec and Chatino. The Chatino languages are all spoken in Oaxaca, and the much larger group of Zapotec languages are spoken in Oaxaca and Veracruz State.

Kaufman (1993) further divides the Zapotec languages into three sub-groups: Northern, Central, and Southern Zapotec. Under this classification system, SLQZ falls into the Central Zapotec group, which includes the Zapotec varieties spoken in the Oaxaca Valley south of Oaxaca City.

The exact number of Zapotec languages is under debate; the SIL Ethnologue (Grimes 2005) currently lists 58 Zapotec languages. Mutual intelligibility (or the lack of it) is standardly used to determine if different varieties of Zapotec spoken in a geographically contiguous area are indeed distinct languages, or the same language with minor dialectal differences. Use of this diagnostic is complicated by the fact that intelligibility between the speech varieties of neighboring communities not always mutually symmetric: as the SIL Ethnologue notes, speakers of San Juan Guelavia Zapotec, a Valley Zapotec language, feel there is a 100% intelligibility rate between their language and the Zapotec variety spoken in Tlacolula. However, speakers of Tlacolula Zapotec perceive only a 58% intelligibility rate with SJG Zapotec.

SLQZ is spoken in the town of San Lucas Quiavini, Oaxaca. It is located about 3 miles outside Tlacolula, a town of about 15,000 people that serves as a regional market center. Like most indigenous towns in Mexico, San Lucas Quiavini takes its name from two sources: a Spanish saint's name, and an indigenous place name. ("Quiavini" is a Hispanicization of *Gyi'bnnii*, which is thought to be derived from a SLQZ word for a type of precious stone.)

About 2000 people currently live full-time in San Lucas (according to 1990 census figures). Most support themselves as farmers. A significant percentage of working-age men from the town live and work in the United States (mostly in the Los Angeles area) while supporting families in San Lucas; other families from San Lucas have settled permanently in the US.

Virtually all residents of San Lucas are fluent in SLQZ. The town's civic affairs are conducted in SLQZ, and children still acquire it as a first language, getting their first exposure to Spanish in elementary school. Residents who have attended school or worked outside San Lucas are bilingual in SLQZ and Spanish (and sometimes English), but many older people, particularly women, are monolingual SLQZ speakers. However, because of the small size of the community and increasing social and economic pressures to assimilate into mainstream Mexican (or American) culture, the language is considered endangered.

The data in this work come from several sources. Unmarked SLQZ examples in this work come from notes collected during a field methods course on SLQZ offered at UCLA in the 1994-1995 academic year or my own fieldnotes taken in subsequent years. Other SLQZ examples

have been taken from ML and from recordings made in San Lucas Quiavini in summer 2004.

1.2.1 Previous Work on the Language

Munro and Lopez's (1999) dictionary of SLQZ was the first comprehensive published record of the language. A number of closely related languages spoken in the region surrounding San Lucas, however, have been closely documented: San Juan Guelavía Zapotec (Jones and Knudsen 1977), Santa Ana del Valle Zapotec (Broadwell 1991), San Pablo Güilá Zapotec (Lopez Cruz 1997), and Mitla Zapotec (Briggs 1961, Stubblefield and Stubblefield 1991). Lopez Cruz, and a number of SLQZ speakers consulted by Munro and Lopez, feel that of these languages, San Pablo Güilá Zapotec bears the closest resemblance to SLQZ.

1.3 A Brief Overview of SLQZ Phonology

SLQZ has a complex phonetic and phonological system, which includes phonemic distinctions among four phonation types, as well as distinct tones.

1.3.1 SLQZ Consonants

In this section, I will briefly outline the SLQZ sound system and the transcription orthography for SLQZ developed by ML, which will be used throughout this work².

The inventory of consonants in SLQZ is seen in Table 1:

² The orthographic system used in this work was originally designed as a practical orthography for SLQZ. However, Munro and Lopez have recently developed a simplified practical orthography for SLQZ, which does not reflect differences in vowel length or phonation type. This system, like the orthographic systems developed for other Zapotec varieties, is designed for use by native speakers who can recover this information from context. (Munro and others still use the older system for transcribing texts and recording new data (P. Munro, p.c.)). I will use this older, more detailed orthography in this work in the interest of providing a detailed record for non-SLQZ speakers.

	stop	fricative	nasal	lateral	sonorant	affricate
labial	p,b	f	mm,m		w	
alveolar	t,d	s,z	nn, n	ll, l	r rr	ts
palatal-alveolar		x, zh				ch
retroflex		x:, zh				
palatal					j, y	
velar	c, g		ng, nng			

Table 1. SLQZ consonants.

Like other Zapotec languages, SLQZ has a fortis/lenis, rather than strict voiced/voiceless, contrast in its consonant pairs. In the chart above, the first symbol in each pair of consonants represents a fortis consonant, the second its lenis counterpart.

The exact phonetic definition of fortis and lenis consonants in Zapotec has long been under discussion (Nellis and Hollenbach 1980, Jaeger 1983). In SLQZ, the contrast between fortis and lenis obstruents generally appears as a difference in voicing; lenis obstruents are generally voiced (but devoiced word-finally), and fortis obstruents are voiceless. However, other acoustic factors distinguish them as well. These differences are clearest in the contrast between fortis and lenis stops: lenis stops, besides being (usually) voiced, are less strongly articulated and tend to be fricated. More subtle differences distinguish fortis and lenis sonorants: fortis sonorants tend to be longer, and vowels preceding them tend to be shorter.

The *r/rr* pair shown above does not represent a fortis/lenis contrast; thus, they are shown on separate lines. Rather *r* is a native phoneme, and *rr* (a trilled *r*) appears in Spanish loanwords or over morpheme boundaries. ML analyze it as a cluster in these contexts; they point out a similar proposal made for Guelavia Zapotec, a language closely related to SLQZ, by Jones and Knudson (1977).

The symbols shown in the chart represent ML's transcription orthography. Consistent with Spanish orthographic rules (and thus the spelling conventions to which most SLQZ speakers are accustomed), the velar stops *c* and *g* are spelled *qu* and *gu*, respectively, before front vowels, as in *qui'lly*, "kilo", and *gui'ihzh*, "dry cornstalk".

1.3.2 SLQZ Vowels

SLQZ has six vowels: three high vowels, two mid vowels, and one low vowel, as seen in Table 2:

i	ë	u
e		o
	a	

Table 2. SLQZ vowels.

The table above represents the vowels in SLQZ orthography. All of these except *ë* are pronounced as they would in IPA. The double-dotted “e” (*ë*) is a high, mid, unrounded vowel; some speakers use it only rarely (replacing it with *e* in most contexts), and it generally appears less frequently than other vowels.

These vowels may be combined to form a number of diphthongs: *ai*, *au*, *ei*, *ue*, *ia,ie*, *iu*, *ua*, *ue*, and *ëi*. ML also note that other diphthongs may also appear in certain Spanish loanwords. SLQZ also has contrastive vowel length; long vowels are written *VV*.

SLQZ has four phonation types. Besides unmarked (modal) phonation, SLQZ shows phonemic contrast among breathy vowels (written in transcription orthography as *Vh*), creaky vowels (written with a grave accent above the vowel (`)), and laryngeal (glottalized) vowels (written *V'*). More than one phonation type may appear within a syllable.

Because of this range of possible contrasts, SLQZ syllables can be quite complex. ML note that the largest possible SLQZ syllable can take the form *CCGVVVC*G, where *C* represents consonants, *V* vowels, and *G* glides. Although an SLQZ syllable may consist of a single vowel, most are consonant-initial and contain more than one vowel.

SLQZ, like other Zapotec languages, is tonal. While tone is clearly phonemically contrastive in most of the Zapotec languages documented thus far (see Black and Pickett (1997), among others), the situation is less clear in SLQZ. ML note a close correlation between phonation type (or combination of phonation type) and tone: so far, no minimal pairs have been found that are identical in form and phonation type, but different only in tone. For this reason, ML suggest that tone may prove fully predictable from the interaction of phonation type, stress, and other factors. This, however, remains an issue for further investigation.

1.4 A Brief Summary of SLQZ Word Order and Grammar

1.4.1 Word Order and Sentence Types

SLQZ, like most Zapotec languages, is a VSO language. It also allows SVO and OVS word order when the fronted argument is interpreted with contrastive focus:

1. Y-tàa'az Gye'eihlly Li'eb
irr-beat Mike Felipe
“Mike will beat Felipe”
2. Gye'eihlly y-tàa'az Li'eb
Mike irr-beat Felipe
“MIKE will beat Felipe”/ “Felipe will beat MIKE”

These examples provide strong evidence that focus is expressed through syntactic movement in SLQZ. This point will be argued for in detail in Chapters 3 and 4.

SLQZ also lacks overt case marking, as seen on the previous examples. In cases where arguments are fronted, the thematic roles of arguments is potentially ambiguous and must be clarified by context: thus, in (2), the focused argument “Mike” can be interpreted as either a subject or an object.

Embedded clauses generally appear without complementizers or other markers of subordination. Their word order is identical to that of matrix clauses:

3. Nài ø-nnaa Gye'eihlly cay-ahcx:ùu'w Li'eb
yesterday neut-say Mike prog-sick Felipe
“Yesterday, Mike said Felipe is sick”

Yes/no questions in SLQZ are formed by the addition of one of three question markers. Two of these (*laàa'* and *uu*) appear sentence-initially, and the third (*èee*) appears sentence-finally. Other than the addition of the question marker, word order within yes/no questions remains the same as that of non-interrogative sentences:

4. Cay-ùall Jwaany li'ebr
prog-read Juan book
“Juan is reading a book”
5. Laàa' cay-ùall Jwaany li'ebr?
Q prog-read Juan book
“Is Juan is reading a book?”

6. Uu cay-ùall Jwaany li'èbr?
Q prog-read Juan boo
“Is Juan is reading a book?”
7. Cay-ùà'll Jwaany li'èbr èèe?
prog-read Juan book Q
“Is Juan is reading a book?”

There are subtle differences in usage and meaning denoted by the choice of question marker; these are discussed in detail in Chapter 5.

Wh-words are fronted in SLQZ; wh-in-situ is disallowed:

8. Xi b-ii'lly-ëng?
what perf-read-3s.prox
“What did he read?”
9. *B-ii'lly-ëng xi?
perf-read-3s.prox what
“What did he read?”

Multiple wh-questions are rare in SLQZ; some speakers do not use them at all, and those who do find them marginal:

10. ?Tu xi b-inylohoh?
who what perf-look at
“Who saw what?”

1.4.2 Other Basic Constructions

SLQZ shows the canonical features of most VSO languages: it has prepositions rather than postpositions, adjectives generally follow nouns, relative clauses are head-initial, and possessive constructions are possessor final.

Like other Zapotec languages (and large number of other indigenous Mexican languages), SLQZ uses body part words as prepositions: for instance, *dehts*, “back”, is used as a preposition meaning “in back of, behind”; *laa'iny*, “stomach”, is used as a preposition meaning “inside”; *lohoh*, “face”, is used as a preposition meaning “at” or “on”. Some examples of these appear below:

11. N-ago'-o' dehts yu'uh
neut-lie-2s.inf. back house
“You're lying in back of the house”
12. N-u'uh bihih laa'iny yu'uh
neut-exist air stomach house
“There is air in the house”

In the remainder of this work, I will gloss these words with their prepositional meanings when they are used as such. (Lillehaugen (2003) shows that children acquire body part terms and homophonous location terms as separate lexical items, and treat them as syntactically distinct.)

SLQZ attributive adjectives generally follow nouns:

13. B-cwààa'ah bùunny pelo't xniàa rò'oh
perf-throw person ball red big
“The man threw the big red ball”

Quantifiers and determiners generally precede the nouns they modify:

14. chòonn zhyàa'p
three girl
“three girls” (from Munro, course notes, 1997)
15. Yra'ta bùunny lohnyààa' r-unydaàa'n zêêi'ny
every person field hab-do-much work
“Every farmer works hard”
16. ra ca'rt
plural letter
“letters”

Munro observes that quantifiers, like many adjectives, can behave syntactically like verbs when used as predicates: pronominal subject agreement markers may attach to them (just as they do to verbs) (17), and they may appear with aspect markers (which obligatorily mark verbs) (18-19):

17. Tyo'p-rëng
two 3p.prox
“(There are) two of them”
18. y-ro'p-rëng
irr-two-3p.prox
“The two of them”
19. s-tyo'p
def-two
“Two more” (examples from Munro, class notes, 1997)

Aspect markers on quantifiers, however, do not have the same semantic usage that they do when attached to verbs: while the Irrealis and Definite aspect markers are usually used to express future events when

attached to verbs, they indicate collective readings and “more” readings, respectively, when attached to quantifiers.

Other verb-like traits of quantifiers noted by Munro are their tendency to appear sentence-initially when used as predicates, and their ability to take certain clitics that normally appear on verbs, such as *-zhya’/-zhyi’*, which indicates epistemic possibility:

20. Chòonn-zhyi’ bùunny m-nnàa lòò’-ng
 three-must person perf-see face-3s.prox
 “Three men must have seen him”
 (from Munro, course notes, 1997)

Nouns without determiners or quantifiers can be interpreted as either definite or indefinite entities, and either singular or plural. Thus, *mni’ny*, “child”, can mean, depending on context “a child”, “the child”, “(some) children”, or “the children”. Use of the plural marker *ra* is purely optional.

Relative clauses are head-initial. The relative marker *nih* appears obligatorily in non-interrogative restrictive relative clauses:

21. Studya’aann nih b-inylohoh Pa’amm n-u’uh rèè’
 student rel perf-see-at Pam neut-exist here
 “The student that saw Pam/ that Pam saw is here”

Headless relatives also appear in SLQZ. They may be used as either free relatives, or, as in the example below, as coreferential with another argument in the sentence in which they appear:

22. Campesyenn n-àa [nih b-zhyàag-a’ nài’]
 farmer neut-be rel perf-meet-1s yesterday
 “The person I met yesterday is a farmer”

Possessive constructions are possessor-final. They are most commonly formed with a possessed nominal preceded by the possessive marker *x:-* and followed by the possessor:

23. x:-ca’rr Gye’eihlly
 poss-car Mike
 “Mike’s car”

Adjectives modifying the possessum appear between the possessum and the possessor:

24. x:-sabaad xníaa wgyee’ihzh-a’
 poss-shoe red expensive-1s
 “my expensive red shoe(s)”

An alternate possessive construction, which apparently does not differ in usage or meaning from the one shown above, is formed with the “dummy” possessed nominal *x:tèe'* or *x:tèe'n* :

25. *x:-studya'aann-a'*
poss-student-1s
“my student”
26. *studya'aann x:-tee'n-a'*
student poss-nom-1s
“My student”

SLQZ has a number of nouns that obligatorily appear with possessors. This group of nouns includes some body parts and certain other inalienably possessed elements. A number of these form possessive constructions without the possessive marker *x:-* :

27. *liahz-a'*
home-1s
“my home”
28. *ru'-a'*
mouth-1s
“my mouth”

Not all nouns that can be considered inherently possessed semantically, however, necessarily appear in possessed form; the SLQZ words *da'ad*, “father”, and *naàan*, “mother”, for instance, may appear without possessors.

A small number of nouns (which are not inherently possessed) have irregular forms in possessive constructions:

29. *bèe'cw*
“dog”
30. *x:-yèe'cw Gye'eihlly*
poss-dog Mike
“Mike’s dog”

1.4.3 SLQZ Verbal Morphology

SLQZ verbs can take complex forms. Besides carrying standard inflectional features (tense and agreement), they may also carry additional morphological material encoding direction, causation, manner, and modality, among other things. In this section, I will provide an overview of these features. I will begin this discussion with a detailed description of

the use and interpretation of SLQZ aspect markers, since this information will be crucial later in this work.

The SLQZ Aspect Markers and Their Uses

SLQZ expresses tense and aspect by prefixing one of seven aspectual markers to the verb stem. Although I will follow longstanding tradition in Zapotec linguistics and refer to these prefixes as “aspect” markers,³ these markers can also express tense and mood as well. SLQZ verbs obligatorily appear with aspect markers; bare verb stems are not used. Six of the seven aspect markers are shown in boldface on the verb stem *-tää’az*, “to beat”, in Table 3:

aspect	-tää’az “beat”	gloss
Habitual	rtää’az	“beats (regularly)”
Progressive	catää’az	“is beating”
Perfective	btää’az	“beat” (past)
Irrealis	ytää’az	“will beat”
Subjunctive	ntää’az	“was going to beat”
Definite	stää’az	“will definitely beat”

Table 3. SLQZ aspect markers.

The seventh aspect (the Neutral aspect, realized as the prefix *n-*) appears on a small number of mostly stative or locational verbs:

31. N-àa-ng banguual
neut-be-3s.prox old
“He/she is old”
32. X:-nnàan-a’ n-u’uh Sann Luu’c
poss-mother-1s neut-exist San Lucas
“My mother is in San Lucas”

Most of these aspect markers have more than one allomorph: the Perfective marker appears as *b-*, *w-*, or *gu-*; the Irrealis appears as either *y*, *chi-*, *g-*, or *l-*; the Subjunctive as *n-* or *ny-*; and the Definite appears

³ This tradition is exemplified in Butler (1988), among others. A notable exception to this convention is Black (1994), who labels the verbal prefixes that encode only tense and aspect as “aspects”, and those that also encode modal information as “moods”. This distinction will be exploited later in this chapter, and will be described in more theoretical terms in Chapter 5.

as either *s-* or *z-*. The Definite and Subjunctive allomorphs are phonologically conditioned (the Definite marker surfaces as *s-* before voiceless-consonant-initial stems and appears as *z-* elsewhere; the Subjunctive form *n-* appears before consonant-initial verb stems and appears as *ny-* elsewhere). The allomorphs for Perfective and Irrealis aspect are lexically selected by verbs.

In his comparative reconstruction of proto-Zapotec, Kaufman (1994) divides verb stems into four classes corresponding to the set of aspectual allomorphs they select: transitive verbs beginning with /u/ or /e/ take the perfective allomorph /b/ while consonant-initial transitive verbs take /g/; transitive or intransitive verbs beginning with sounds other than /p/ and /k/ and verbs with transitive/intransitive (causative/versive) alternations take the same set of allomorphs. A similar classification system was proposed for Guevea de Humboldt Zapotec by Marks (undated ms.). Her classification system differs crucially from Kaufman's in that she assumes no semantic motivation for the different classes; aspectual allomorphs are either lexically selected or phonologically determined. I will not pursue this issue further.

Linguists working on Zapotec have traditionally referred to the temporal prefixes as “aspect” markers because they overtly convey the internal structure of events rather than the temporal relation to the speaker. A simple clause with a verb marked with progressive aspect, for instance, could be used to express a present, past, or future act in progress:

33. Ca-beèz-a' liu'
 prog-wait-1s you
 “I am/was/will be waiting for you”

Many of these markers, however, also encode tense and modal information. This has been shown to be the case in other Zapotec languages as well.

In her 1994 dissertation on Quiévolani Zapotec, Cheryl Black divides the aspect markers of that language into two groups: those that denote purely temporal relations (aspect and tense), which she labels “aspects”; and those that denote modality (the relation of events to sets of possible worlds), which she labels “moods”. This distinction holds in SLQZ (although, as I show below, the aspect markers that denote modality can also behave non-modally and simply encode tense and aspect information). The division of SLQZ aspects into what I will call modal and non-modal groups is seen in Table 4:

Non-Modal Aspects		Modal Aspects	
Habitual	r-	Subjunctive	ny-
Perfective	b-, gu-, m-, w-	Irrealis	y-, g-, ch-, l-
Progressive	ca-, cay-	Definite	z-, s-
Neutral	n-, Ø		

Table 4. Modal and non-modal aspect markers in SLQZ.

Uses of Non-Modal Aspects

The functions of the four non-modal aspects are fairly straightforward.

The habitual marker *r*, as its name implies, is used to denote ongoing or regularly repeated states or events:

34. R-àa'p-a' teihby li'ebr
 hab-have-1s one book
 "I have one book"

The progressive marker expresses immediately ongoing events or states, as seen in (33).

The Perfective marker is used to denote completed actions (either completed in the past or in the future):

35. B-guhty-a' bzihny
 perf-kill-1s mouse
 "I killed a mouse"

36. Yzh:ii chih y-zëhny-a' al b-da'uh Gye'eihlly
 tomorrow when irr-arrive-1s already perf-eat Mike
 "When I arrive tomorrow, Mike will have already eaten"

The Perfective marker is also used to form affirmative singular imperatives. In this imperative structure, no subject agreement marker appears. This is the one case in which the Perfective aspect serves a modal, rather than purely aspectual, function:

37. B-da'uh!
 perf-eat
 Eat!

The Neutral marker *n* (or its null allomorph) appears on only a small number of verbs, which are, for the most part, stative or locational.

Among these are *ru'uh*,⁴ “exist”, and *nàa*, “be”, verbs denoting temporary states (*ra'tga'ah*, “lies down”), and verbs denoting knowledge (*naann*, “know”):

38. Me's n-àa Jwaany
teacher neut-be Juan
“Juan is a teacher”

Uses of Modal Aspects

The modal aspects show a wider and more complex range of possible interpretations than the non-modal ones. These interpretations include non-modal as well as modal readings. In this section, I will provide a brief descriptive overview of the possible interpretations of each of the modal aspects. A direct correlation between the modal and non-modal readings of these aspects will be proposed and argued for in Chapter 6.

In this chapter, I assume informal definitions of “modal” and “non-modal”. “Non-modal”, for the purposes of this discussion, are those in which the event described is taken to occur in the actual world of the speaker and listener.

An example of a non-modal reading can be seen in (39):

39. Y-tò'oh Gye'eihlly ca'rr
irr-sell Mike car
“Mike will sell the car”

In (39) the verb “sell” refers to an event assumed to take place at a later time in the actual world containing Mike and the speaker. The proposition of Mike selling the car at a later time is presumed to be a real event in the real world: the speaker would not have uttered this sentence if she or he did not believe it would be true that Mike would sell his car. This is thus a case in which one of SLQZ's modal aspects (the Irrealis) receives a non-modal interpretation.

I will define “modal” readings here as those expressing the relationship between an event and the actual world of the speaker and listener. An example of a modal reading of the Irrealis aspect is its interpretation as a complement of “want” in (40):

40. R-càa'z y-tò'oh Gye'eihlly ca'rr
hab-want irr-sell Mike car
“Mike wants to sell the car”

⁴ Following the convention set forth in the SLQZ dictionary, I cite verbs in isolation with the habitual marker *r-*, except in cases such as *nàa*, “be”, where no habitual form exists.

In (40), the event of Mike selling the car does not take place the actual world in which Mike exists (since it's a potential, rather than actual, event) but rather in the set of possible worlds denoted by Mike's desire. In contrast to (39) above, in which the event of Mike selling the car at some future time is presumed to be true, in this case, the event is expressed as possible, but the speaker and listener are not committed to believing it will (or won't) actually take place.

These admittedly sketchy definitions will be refined and elaborated upon in Chapter 5. Now I return to the description of the distribution and interpretation of the three modal aspects.

The examples above showed two of the most common uses of the Irrealis aspect. In matrix clauses, it is used to express future events, as seen in (39) above and (41) below:

41. Y-da'uhw-ënn gueht
irr-eat-1p tortilla
"We will eat tortillas"

It is also used in complement clauses of intensional verbs and in embedded imperatives:

42. R-càa'z-a' y-guhty-a' bzihny
hab-want-1s irr-kill-1s mouse
"I want to kill the mouse"
43. R-e'ihpy-a' Gye'eihlly y-tòò'oh ca'rr
hab-tell-1s Mike irr-sell car
"I told Mike to sell the car"

It also appears in the complements of certain modals:

44. N-àa pahr y-tòò'oh Gye'eihlly ca'rr
neut-be for irr-sell Mike car
"Mike has to sell the car"
45. Z-àa'lle'eh g-uuny bùunny nadaar rée'
def-allow irr-do person swim here
"Swimming is allowed here"

It is worth noting that the contexts in which Irrealis verbs receive modal readings in SLQZ are closely parallel to those in which subjunctive marking is assigned to verbs in Romance (and other) languages.

The Definite aspect is most commonly used instead of the Irrealis aspect to express strong speaker presupposition about the occurrence of a future event. By using the Definite aspect, the speaker expresses a belief that an event will “definitely” happen; thus, the name given to this aspect:

46. Z-u’uh cla’s Myee’rcw
def-exist class Wednesday
“There will (definitely) be class Wednesday

This is the usual usage of Definite verbs in matrix clauses.

Besides their stronger implication of speaker presupposition, Definite verbs also differ from Irrealis verbs in their syntactic distribution. Most notably, while verbs with other aspects freely allow preverbal subjects or objects with contrastive focus readings (as seen in (1) and (2)), verbs with Definite aspect generally disallow preverbal arguments:

47. S-tàa’az Gye’eihlly Li’eb
def-beat Mike Felipe
“Mike will definitely beat Felipe”
48. *Gye’eihlly s-tàa’az Li’eb
Mike def-beat Felipe
“Mike will definitely beat Felipe”

A syntactic and semantic account for this asymmetry will be presented in Chapters 4 and 5.

The presence of two distinct aspect markers, distinguished by syntactic behavior, to express future events is also attested in Quiégolani Zapotec (hereafter, QZ) (Black 2004). In QZ, the two aspects that can be used to describe future events (which Black labels “Future” and “Potential”) are virtually interchangeable semantically; Black reports that either can be used in future contexts with no change in meaning. There are, however, distributional constraints that distinguish the QZ Potential and Future aspects. While verbs with Future aspect (which appears cognate with SLQZ Definite aspect) may appear in QZ yes/no questions, verbs marked with Potential aspect (which appears cognate with SLQZ Irrealis aspect) may not:

49. Pe s-oo de nis
Q fut-drink 2s water
“Will you drink water?”
50. *Pe g-oo de nis
Q pot-drink 2s water
“Will you drink water?”
(Quiégolani Zapotec: Black 2004)

A similar constraint distinguishes SLQZ Definite and Irrealis aspects. In contrast to QZ, which has a single construction for yes/no questions, SLQZ has three distinct yes/no question particles:

51. Nu'uh tu b-da'uh nài' èee?
 exist who perf-eat yesterday Q
 "Did anyone eat yesterday?"
52. Làa' nu'uh tu b-da'uh nài'?'
 Q exist who perf-eat yesterday
 "Did anyone eat yesterday?"
53. Uu nu'uh tu b-da'uh nài'?'
 Q exist who perf-eat yesterday
 "Did anyone eat yesterday?"

A detailed account of these markers will be presented in Chapter 5. (SLQZ also has a number of particles that form tag questions, which I do not include here).

The last of the question particles cited above, *uu*, differs most clearly from the others in distribution and meaning. While *èee* and *làa'* are used when the speaker asking the question is genuinely unsure of the answer, use of *uu* implies that the speaker is already presupposing a positive answer, and is simply asking for this presupposition to be confirmed. Also, while verbs with both Irrealis and Definite aspect may appear in questions with *èee* and *làa'*, Irrealis verbs may not appear in *uu* questions:

54. Uu z-a'uw-u' beèe'l?
 Q def-eat-2s.inf. meat
 "Will you eat meat?"
55. *Uu g-a'uw-u' beèe'l?
 Q irr-eat-2s.inf. meat
 "Will you eat meat?"

Thus, the Definite and Irrealis aspects differ in not only interpretation, but syntactic distribution.

Verbs with Definite marking can also appear as complements of certain verbs. In some cases, these complement verbs may appear with either Definite or Irrealis aspect. The choice of aspect in these cases lends slightly different interpretations to the sentence:

56. R-ralloh Li'eb s-tò'oh/*y-tò'oh Gye'eihlly ca'rr
 hab believe Felipe def-sell/*irr-sell Mike car
 "Felipe thinks Mike will sell the car"

57. B-inydiahg Li'eb s-tò'o'h/y-tò'o'h Gye'eihlly ca'rr
 perf-hear Felipe def-sell/irr-sell Mike car
 "Felipe heard that Mike will sell the car"

In (56), use of the Definite aspect in the complement clause means Felipe is sure that Mike will sell the car; use of the Irrealis in (57), on the other hand, means Felipe heard that Mike will sell the car but is not necessarily committed to believing the truth of this proposition.

It is interesting to note that the verbs that select Definite versus Irrealis complements to express future events correspond closely to those that select indicative versus subjunctive complements in other languages, such as the Romance languages.

In a small number of verbs (mostly verbs of motion), Definite allomorphs may be used instead of Perfective to express past actions or events:⁵

58. Cë'ity r-ielldyalaa'z-dy-a' gw-èe-ng Me'ijy
 neg hab-believe-neg-1s perf-go-3s.prox Mexico
 "I don't believe he went to Mexico"
59. Cë'ity r-ielldyalaa'z-dy-a' z-èe-ng Me'ijy
 neg hab-believe-neg-1s def-go-3s.prox Mexico
 "I don't believe he went to Mexico"

There is a slight difference in presupposition implied by the choice of Perfective or Definite aspect in these contexts: (58) would be used if the person under discussion were already back from some trip and the speaker didn't believe he ever went to Mexico. (59), in contrast, would be used if the person under discussion were still gone, and the speaker didn't believe he's currently in Mexico.⁶

The Subjunctive aspect is not frequently used in matrix clauses, but when it does appear, it expresses incompleted past actions:

60. N-tò'o'h Gye'eihlly c'arr
 subj-sell Mike car
 "Mike was going to sell the car (but didn't)"

It is often used instead of the Perfective in negative statements or questions with past readings. Although Perfective verbs may appear with clausal negation and in negative questions, my consultant consistently volunteers Subjunctive forms first in these contexts:

⁵ Black (2004) proposes that this *z-* prefix, which appears on a small number of motion verbs in a number of Zapotec languages, is not a Definite allomorph at all but a distinct marker denoting actions in progress.

61. Cë'ity n-tòò'oh-dya' Gye'eihlly ca'rr
 neg subj-sell-neg Mike car
 "Mike didn't sell the car"

There seems to be no clear semantic difference between the negated variants with Subjunctive versus Perfective aspect.

The Subjunctive aspect also appears as the complement of modals and intensional verbs with Perfective aspect to obtain past-tense readings:

62. G-uhclaaaz-a' n-tàà'z-a' Li'eb
 perf-want-1s subj-beat-1s Felipe
 "I wanted to beat Felipe"
63. N-àà pahr n-tàà'z-a' Li'eb
 neut-be for subj-hit-1s Felipe
 "I should have hit Felipe"
64. Cë'ity n-àà-dya' pahr n-tàà'z-a' Li'eb
 neg neut-be-neg for subj-hit-1s Felipe
 "I shouldn't have hit Felipe"

The Subjunctive, then, appears to serve as the past-tense form of the Irrealis in complement clauses. This shows clearly the existence of tense-shifting in SLQZ, and thus the necessity of recognizing tense as well as aspect as part of SLQZ's syntactic system.

The modal aspects can thus be summarized as follows: the Subjunctive aspect marker seems to express actions that are incomplete in relation to a past reference time, the Irrealis aspect marker expresses actions that are incomplete in relation to a present reference time, and the Definite marker expresses highly possible events in the future.

To sum up, the modal and non-modal aspects in general can be distinguished in the following ways: The non-modal aspects denote events extensionally anchored to the actual world, while modal aspects may refer to hypothetical or potential, rather than actual, events. The non-modal aspects generally keep the same interpretation in all syntactic environments, while the modal aspects can vary in meaning in different environments. In the following chapters, I will develop and show evidence for a structural account for these contrasts.

1.4.4 Pronouns and Pronominal Clitics

Pronominal subjects appear as clitics that follow the verb stem.

SLQZ has no subject agreement morphology for non-pronominal (that is, lexical, clausal, wh-word, or quantificational) subjects. This is one of the reasons the forms listed below are considered pronominal arguments themselves, rather than agreement markers.

ML list 18 possible clitics for pronominal subjects in SLQZ:

Person/Number	Clitic	Gloss
1s	bii'llya'	"I read"
1p	bii'llyënn	"we read"
3s proximate	bii'llyëng	"he/she/it (nearby) read"
3p proximate	bii'llyrëng	"they (nearby) read"
3s distal	bii'llyih	"he/she (out of sight) read"
3p distal	bii'llyrih	"they (out of sight) read"
3s animal	bii'llyëmm	"he/she/it(animal/child) read"
3p animal	bii'llyrëmm	"they (animals/children) read"
2s informal	bii'llyu'	"you (informal)read"
2p informal	bii'llyahd	"you (plural, informal) read"
3s respectful	bii'llyahzh:	"he/she (respectful) read"
3p respectful	bii'llyrahzh:	"they (respectful) read"
2s formal	bii'llyëbu'	"you (formal) read"
2p formal	bii'llyëbud	"you (plural, formal) read"
3s formal	bii'llyëb	"he/she (formal) read"
3p formal	bii'llyrëb	"they (formal) read"
3s reverential	bii'llyiny	"he (God) read"
3p reverential	bii'llyriny	"they (gods/saints) read"

Table 5. Pronominal subject clitics (on Perfective form of "read").

ML observe (as shown above) that SLQZ third-person pronouns four distinct levels of reference to living beings, depending on age and social status. Two other forms of reference, the distal and proximate, are determined by the proximity of the referent to the speaker: pronominal subjects the speaker can see at the time of utterance are expressed with the proximate forms; those that are out of the speaker's sight are expressed with the distal forms. These forms can be used to refer to both people and inanimate objects. The usage of the remaining forms is determined by the social standing of the speaker and the referent in the

community. (First-person subject agreement markers are not explicitly marked for proximity or social level; second-person pronouns show a two-way distinction: formal and informal.) The third-person animal form is used to refer to animals and children; the respectful form is used to refer to people who have reached adulthood or who have proven themselves capable of doing the work of an adult: even adults can be referred to with the animal forms if they are thought not to have met the normal requirements of adulthood (Pam Munro (class lectures) reports Felipe Lopez's observation that even an older woman who has never married can be referred to with the animal form.) The formal form is used to refer older people or those with higher social standing, and the reverential form is used in reference to God, saints, particularly salient natural entities (such as the sun, moon, and water), and physical entities with special cultural salience (such as tortillas).

The singular reverential form is also used as a grammatical subject in a number of subjectless, idiomatic constructions (P. Munro, p.c.):

65. B-làiny primeer gw'eell b-dèèi'dyag-a'
 perf-be.fortunate-3s rev. first time perf-cross-1s
 "It was fortunate that I crossed the first time"
 (from ML)

In these constructions, no other lexical or pronominal subject is possible.

SLQZ lacks object agreement as well as subject agreement. Pronominal objects are expressed in one of two ways: with a separate series of morphologically independent pronouns or with one of the clitic forms described above.

Pronominal object clitics follow subject clitics at the right edge of the verb stem (66). If the subject is lexical, the object clitic cliticizes to the subject (67):

66. B- dêèi'dy-a'-ng Li'eb
 perf-give-1s.-3s.prox Felipe
 "I gave it to Felipe"
67. B-tòò' Crisy-ëng
 perf-sell Cris-3s.prox
 "Cris sold it"

The morphologically independent pronouns are shown in Table 6. Note that the independent pronoun forms (with the exception of the first-person forms) can be analyzed as combinations of a base form *laa* (which has been analyzed as a focus particle) and a bound subject clitic:⁷

⁷ See Lee 1995 for evidence that fronted independent pronouns are multimorphemic, and that constructions with fronted independent pronouns are clefts.

Person/Number	Independent Pronoun
1s	nàa'
1p	dannoohnn
3s proximate	la'anng
3p proximate	làa'rëng
3s distal	la'ai
3p distal	làa'rih
3s animal	làa'mm
3p animal	làa'rëmm
2s informal	liu'
2p informal	làa'd
3s respectful	làa'zh:
3p respectful	làa'razh:
2s formal	làa'yuu
2p formal	làa'yuad
3s formal	làa'b
3p formal	làa'rëb
3s reverent.	làa'iny
3p reverent.	làa'riny

Table 6. Independent pronouns in SLQZ.

Independent pronouns may be used as both direct and indirect objects:

68. Y-dêi'dy-a' buhdy la'anng
 irr-give-1s chicken 3s.prox
 "I will give him a chicken"
69. R-yu'làaa'z Gye'eihlly la'anng.
 Hab-like Mike 3s.prox
 "Mike likes him/her"

These independent pronoun forms may also be used as emphatic subjects with focused readings. In this capacity, they (1) must co-occur with a corresponding bound subject clitic with the same person/number and formality features, and (2) may only appear in preverbal, not postverbal, position:

70. La'anng ca-nzàa-ng Meijy
3s.prox. prog-visit-3s.prox Mexico
"HE is visiting Mexico" (ML vol 1, p. 23)

71. *Ca-nzàa-ng la'anng Meijy

A second, less frequently used series of independent pronouns, called "nominal pronouns" by ML, also exists: These are used only as subjects, occur only in third person, and like the ordinary independent subject pronouns, may appear only preverbally. They differ from other independent pronouns in that they appear without any corresponding subject clitic on the verb stem. Compare the following example to (70):

72. A'anng ca-nzàa Meijy
3s.prox.nom prog-visit Mexico
"He is visiting Mexico"

Nominal pronouns consist of a base *àa'* followed by one of the twelve third-person clitic forms, as seen in Table 7.

The precise semantic contexts in which these forms are used is still unclear. ML note that they tend to appear in single-clause sentences containing locational or movement verbs, and in some cases seem to have some demonstrative force. One of my speakers sometimes feels they fit best in contexts describing a known subject: thus, they have a topic-like function. This remains an issue for future investigation.

A number of other elements may also be affixed to the verb stem. These may appear affixed to either the left or right edge of the verbal stem.

1.4.5 Preverbal Affixes

Many SLQZ verbs have causative alternates. These forms, which I will call "morphological causatives", are formed by either the addition of a causative morpheme or a suppletive alternation at the left edge of the verb stem, following the subject agreement marker:

Person/Number	Nominal Pronoun
3s. proximate	a'anng
3p. proximate	arëng
3s. distal	a'ai
3p. distal	arih
3s. animal	a'mm
3p. animal	arëmm
3s. respectful	a'àzh:
3p. respectful	arahzh
3s. formal	àab
3p. formal	arëb
3s. reverential	àiny
3p. reverential	ariny

Table 7. SLQZ nominal pronouns.

73. r-ihnnih
 hab-gets light
 “gets light” (of the sky, before dawn)
74. r-z-ihnnih
 hab-caus-gets.light
 “turns on (a light)”
75. r-yiuh
 hab-gets ground
 “gets ground up”
76. r-z-iuh
 hab-caus-gets ground
 “grinds up, pulverizes”

(SLQZ also has a periphrastic causative construction formed with the verb *ruhny*, “make” with a sentential complement.)

The actual forms of the morphological causative marker are fairly varied. The most common forms are *z-*, *gu-*, *gw-*, and fortition of root-initial lenis consonants. Examples of these are shown below:

Causative with z-:

77. r̀eè'cy
“burns” (intr.)
78. rz̀eè'cy
“burns” (trans.)

Causative with gw-:

79. riè'd
“gets braided” (of hair)
80. rgwèè'd
“braids (hair)”

Causative with fortition of lenis consonant:

81. rgàa'ah
“gets caught”
82. rcàa'ah
“takes, gets”

Another set of elements that may precede verb stems in SLQZ are directional markers. These markers, reduced forms of the verbs “come” and “go”, give the meanings “comes to V” and “goes to V”, respectively:

83. rgye'eht
“plays”
84. ri'cye'eht
“goes to play”
85. ra'uh
“eats”
86. ri'dta'u
“comes to eat”
87. ri'ta'u
“goes to eat”

Directional markers precede morphological causative stems:

88. Z-ied- sya'a' Li'eb Gye'eihlly
 def-come-make.dance Felipe Mike
 "Felipe came to make Mike dance"

1.4.6 Postverbal Affixes

A larger, more varied set of elements may follow the verb stem in SLQZ. Some of the more common ones are shown below. Munro 1997 notes that postverbal affixes fall into two basic groups: those that appear directly adjacent to the verb stem and behave like part of the verb stem, which she calls "secondary roots", and postverbal clitics, which appear to form a phonological unit with the verb stem, but not be closely attached syntactically. Secondary roots also differ from clitics in their syntactic distribution: they may only affix to verbs, while there are a large number of clitics that may cliticize to both verbs and other constituents, such as prepositional phrases and nominals. The postverbal clitics themselves fall into a number of different groups depending on their usage and distribution; their grammar is quite complex, and I will not attempt a full description of these elements. Rather, I will give a few examples of their more typical usage.

The applicative morpheme *nèe* is the most common of the secondary roots. It may appear directly after the verb root and before the subject agreement marker. *Nèe* increases the valence of the verb and allows the introduction of an indirect object:

89. B-da'uh-a' rro's
 perf-eat-1s rice
 "I ate rice"
90. B-da'uh-nì -a' Gye'eihlly rro's
 perf-eat-app-1s Mike rice
 "I ate rice with Mike"

(where /e/ becomes [i] before a low vowel)

Another postverbal particle that behaves similarly is *daààn*, an intensifier that is usually glossed as "a lot". Like *-nèe*, it appears directly adjacent to the verb stem:

91. R-a'uw-daàa'n Gye'eihlly bx:àady
 hab-eat-a.lot Mike grasshopper
 "Mike eats a lot of grasshoppers."

It may not co-occur with *-nèe* in a verbal complex:

92. *B-da'uw-daàa'n-nèe Gye'eihlly Li'eb bx:àady
 perf-eat-a.lot-appl Mike Felipe grasshopper
 "Mike ate a lot of grasshoppers with Felipe"

93. *B-da'uw-nèe-daàa'n Gye'eihlly Li'eb bx:àady

On the assumption that productive word formation processes occur at the syntactic level, this suggests the possibility that *daàa'n* and *nèe* occupy the same syntactic position. This possibility will be discussed in the next chapter.

Other morphemes (generally aspectual adverbs and expressions of probability) may appear after the verb root (and after secondary roots, if present) but before the subject agreement marker. SLQZ has a large inventory of such morphemes (in contrast to other Zapotec languages, such as Quiégolani Zapotec (Black 2004), which has only two such possible morphemes). A few examples of postverbal markers in SLQZ appear below. These do not represent an exhaustive listing of possible postverbal suffixes:

94. N-u'u-g-zhya-rëng Los Angl
neut-exist-still-might-3p.prox Los Angeles
“They might still be in Los Angeles”

95. Ca-ya'uh-ru-zhya-rëng gueht
prog-eat-more-might-3p.prox tortillas
“They might be eating more tortillas”

-Zhya' expresses epistemic probability; I have thus glossed it “might” in the examples above. As the preceding examples show, more than one adverbial expression may attach to a verb. They always appear, however, in fixed order in relation to each other: *-zhya'*, for instance, always follows adverbial morphemes such as *-ag*, “still”, and *-ru'*, “more”.

In summary, then, the template for possible ordering of morphemes on SLQZ verb roots is as follows:

ASP (dir.)(causative) ROOT (sec. root)(adv.)(adv.)(SAM)(Obj.clitic)

In Chapter 3, I show that this ordering of verbal morphemes poses problems for generally accepted theories on verb movement and how morpheme order reflects underlying syntactic structure.

2 Background and Theoretical Assumptions

2.1 Overview

This chapter addresses the historical and theoretical proposals assumed in this work. Because the central focus of this book is an alternative derivation of VSO word order and its consequences for the syntax of SLQZ and other VSO languages, this chapter summarizes some of the previous proposals about the derivation of VSO languages, and shows (1) the features of VSO languages (including SLQZ) that they attempt to address and (2) how these proposals all fail to account for the word order and morphological ordering facts of SLQZ. Then, I briefly summarize Kayne's (1994) Antisymmetry program, which forms the theoretical basis for this work. I assume Kayne's definitions for most of the technical terms (such as "c-command" and "adjunction") used in the rest of this work.

2.2 How Is VSO Word Order Derived? Some Previous Accounts¹

The question of how VSO word order is derived has long been debated by linguists. This section briefly summarizes some of the earlier proposals for deriving VSO word order, and considers their possible applications to SLQZ. I then show that there is strong theoretical and empirical evidence that an alternative derivation for VSO word order is needed to account for the word order constraints and morphological ordering constraints of SLQZ.

¹ Much of the following section is based on the extremely comprehensive review of VSO literature in Carnie 1995.

2.2.1 VSO as a Distinct Derivation: Flat Structures

The earliest accounts of VSO syntactic structure in a generative framework assumed an underlying structure distinct from that of SVO and various other language types. These accounts (Awberry 1976, Chung 1976, among others) assumed that VSO languages had verbs, but not VPs. The structures were assumed to be flat:

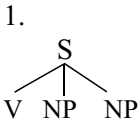

Justification for this structure came from the assumption that since verbs and objects are not contiguous in VSO languages, they cannot form a distinct syntactic constituent. Under the assumption that VSO languages are derived from structures such as (1), verbs and objects in VSO languages should not be able to appear together as syntactic units, and should not be able to undergo movement or other syntactic processes as a unit.

This prediction, however, is not borne out. It has been widely noted that some VSO languages (such as the Celtic languages) allow verbs and their objects to be clefted² (the following examples are cited in Carnie (1995), p. 40):

2. Gweld y ci y mae'r dyn
 see the dog wh be-the man
 "It's seeing the dog that the man is" (Welsh, from Sproat 1985)
3. Lenn eul levr brezhoneg a ran bembez
 to-read a book breton wh do-I every day
 "Read a Breton book is what I do every day
 (Breton, from Anderson and Chung 1977)

This suggests that, at least in the Celtic languages, verbs and objects do indeed form constituents – that is, VPs – that may undergo movement.

Further evidence against flat structures for VSO languages comes from subject/object asymmetries in binding relations. If subjects and objects are indeed sisters dominated by the same node (as seen in the tree above), they should be able to enter freely into binding relations with each other, since they are mutually c-commanding. This, however, proves not to be the case: Carnie (1995), citing work by Woolford

² These languages are a notable exceptions to the general crosslinguistic prohibition against clefted predicates (Heggie 1988, McCawley 1988). SLQZ also prohibits clefted predicates (Lee 1997b).

(1991), notes that Niuean allows reflexive objects to take pronominal antecedents:

4. Fana n-e ia a ia ni neafi
 shoot empf-erg him abs. him refl yesterday
 “He shot himself yesterday”
 (Seiter 1981, p. 80, cited in Woolford 1991)

If it were the case that VSO structures were flat, then this sentence would be ungrammatical: if the object “himself” were allowed to c-command the subject “him”, then a violation of Principle B of the Binding Theory would result. Since this sentence is grammatical, however, it cannot be the case that the object and subject mutually c-command each other.

Similar subject/object asymmetries also occur in SLQZ. The following examples show subject/object asymmetries with the reflexive possessive marker *-ni'*. *-Ni'* marks nominals to indicate their possession by a preceding, non-pronominal nominal.³ In simple VSO sentences, possessed objects, but not subjects, may be marked with *-ni'*:

5. Gw-àa'izy Gye'eihlly be'ts-ni'
 perf-hit Mike brother-refl.poss.
 “Mike_i hit his_j brother”
6. *Gw-àa'izy be'ts-ni' Gye'eihlly
 perf-hit brother-refl.poss Mike
 “His_i brother hit Mike_j”

This clearly shows that subjects and objects are not in a symmetric relation with each other in either SLQZ or Niuean, and suggests that VSO word order involves more hierarchy than the flat structure in (1) presumes.

³ See Munro (1995) for a detailed description of the distribution and usage of *-ni'*.

2.2.2 VSO Derived from SVO: An Overview⁴

Later alternatives to the flat structure are based on the assumption that VSO word order is derived from SVO word order by additional movement (either movement of the verb to the left of the subject, as proposed by Emonds 1980, among others); or movement of the subject to the right of the verb (as suggested by Choe 1987 and Chung 1990); or less movement (assuming subjects are generated VP-internally, subjects may potentially remain situ in VP while the verb itself raises to the left of the subject to the inflectional position in which verbs normally surface in SVO languages (Koopman and Sportiche 1991)).

2.2.3 VSO Derived by Verb Raising

Emonds (1980) argues that the typological facts of VSO languages support the idea that they are derived by verb raising to a complementizer position, as seen below:

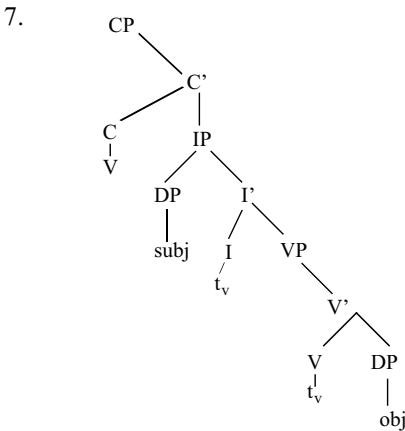

In support of this thesis, Emonds cites Greenberg's Sixth Universal (1966), which claims that all VSO languages also have alternate SVO word order, and his Twelfth Universal, which asserts that languages with

⁴ A number of the following alternate proposals for deriving VSO word order were developed before Pollock's (1989) idea (which I have assumed throughout this work) that verbal inflectional material is contained in separate functional projections including tense (TP) and agreement (AgrP). Rather, they follow the older assumption that all inflectional information is contained in a single functional projection I(inflection) P. In summarizing these proposals, I will use the terminology of the original work.

predominant VSO word order have clause-initial question particles, while languages with predominant SOV word order do not. Emonds thus associates VSO word order with the presence of clause-initial particles, which motivate verb movement to pre-subject position. The alternate SVO word order available to predominantly VSO languages results from the absence of verb movement.

Parallels have also been drawn between the derivation of VSO word order by verb movement from I to C and verb-second languages such as German, which have been analysed as requiring obligatorily filled complementizer positions (Den Besten 1983, among others). In matrix clauses, for instance, German verbs raise obligatorily to C, and another constituent (such as an argument or an adverb) raises to a preverbal Topic position:

8. Gestern kaufte Karl dieses Buch
 yesterday bought Karl this book
 “Karl bought this book yesterday” (Carnie 1995, p. 60)

In clauses containing overt complementizers, however, verbs appear clause-finally:

9. Ich dachte [dass Karl gestern das Buch gekauft hat]
 I thought [that Karl yesterday the book bought has]
 “I thought that Karl bought the book yesterday”
 (Carnie 1995, p. 60)

The complementary distribution between overt complementizers and verbs in second position is seen as evidence that verbs in second position land in C. The presence of overt complementizers blocks this movement, thus deriving the verb-final construction in (9).

VSO languages have thus been argued to be “weak” verb-second languages: like verb-second languages such as German, they require verbs to raise from I to C, but unlike German, they do not require the specifier of CP to be filled.

This proposal, however, fails to account for the word order facts of SLQZ. While SLQZ does not use complementizers to introduce embedded clauses, it does require complementizers in relative clauses.⁵ The following analysis will thus use relative clauses as a diagnostic for the possibility of verb-raising to C in SLQZ. Relative clauses in SLQZ, which obligatorily contain complementizers, still allow VSO word order and actually disallow SVO order:

⁵ Pamela Munro (p.c.) and Gallant 1995 argue that the SLQZ relative marker *nih* is indeed a complementizer rather than a relative pronoun.

10. Studya'aann nih b-dêidy Gye'eihlly li'ebr
student rel perf-give Mike book
“the student Mike gave the book to”
11. * Studya'aann nih Gye'eihlly b-dêidy li'ebr

This suggests that verbs do not raise as high as C in SLQZ relative clauses. (The possibility of VSO word order within relative clauses has also been attested in Irish, cf. Koopman and Sportiche (1991).)

2.2.4 Subject Lowering

Subject lowering has also been proposed as a source of VSO ordering. One such account was proposed for Berber by Choe (1987). She argues that the ordering of the verb, subject, and inflectional elements in examples such as the following point to subject lowering:

12. Ulli t-ttett Tifa iselman
neg.imp 3fs-eat Tifa fish
“Tifa is not eating fish”
(Choe 1987, cited in Carnie 1995, p. 49)

Inflectional elements such as agreement and tense are generally assumed to be generated above VP in a separate inflectional projection (IP) or in a set of separate inflectional projections (such as separate projections for tense and agreement, for instance). Since the inflectional and agreement material precede the verb in Berber, Choe argues that the verb itself remains in situ inside VP. (It is widely assumed that in languages with post-verbal inflectional marking, such as the Romance and Germanic languages, verbs raise out of VP and incorporate with inflectional material in IP (Pollock 1987, among others).) The postverbal position of Berber subjects results from lowering of subjects (which Choe assumes to be generated in the specifier of IP) to a VP-adjoined position:

13.

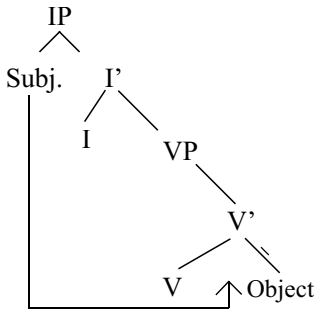

If this account is correct, it could potentially account for the ordering of tense/aspect marking and verbs in SLQZ: aspect markers are generated in I, verbs remain in situ, and subjects generated in spec, IP lower to VP and adjoin to it. This would account for both the verb-initial word order of SLQZ and the fact that aspect markers in SLQZ precede verbs.

This analysis, however, poses both theoretical and empirical problems for SLQZ. From a theoretical viewpoint, it violates the ban on rightward movement forced by antisymmetry requirements (which will be outlined in the next section). It is also inconsistent with the contemporary view that subjects are generated as specifiers of VP. From an empirical viewpoint, it fails to account for the fact that the SLQZ verbs and their aspect markers behave as a unit in constructions such as negation: under clausal negation, verbs and their aspect markers appear between two negative morphemes, as seen in (15):

14. B-da'u Gye'eihlly bx:àady
 perf-eat Mike grasshopper
 "Mike ate grasshoppers"
15. Cě'ity b-da'u-dya' Gye'eihlly bx:àady
 Neg perf-eat-neg Mike grasshoppers
 "Mike didn't eat grasshoppers"

This suggests that the complex formed by a verb and its aspect marker must be a syntactic constituent, not just two separate, adjacent constituents.

2.2.5 Subject in Situ

Both the verb-raising and subject-lowering accounts of VSO word order outlined above were based on the assumption that subjects are generated as specifiers of IP. VSO word order is thus derived by either raising the verb past IP or lowering the subject to a postverbal position inside or adjoined to VP.

More recently, however, it has been commonly assumed (Koopman and Sportiche 1991, among others) that subjects are not generated in inflectional projections, but inside the verb phrase itself. (Koopman and Sportiche explicitly assert that the subject is generated as a sister of VP, thus forming a small clause with VP, but this is not crucial for the following analysis.) Base-generating subjects VP-internally brings subjects into line with objects, which have long been assumed to be generated VP-internally, and is consistent with the fact that verbs, not inflectional categories such as tense and agreement, subcategorize arguments and determine thematic structure.

Under this analysis, VSO results when verbs raise from V to I (through TP and AGRSP, in more contemporary terms), leaving the subject in VP, to the right of the inflected verb:⁶

16.

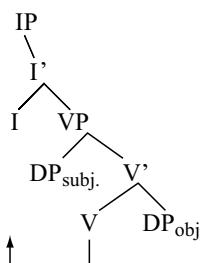

Koopman and Sportiche propose that VSO languages differ from SVO languages in the case marking features of I: in SVO languages, I may case-mark its specifier, thus subjects raise to the specifier of IP to receive case-marking. In VSO languages, on the other hand, I may only assign case by head-government (that is, it can only case-mark directly adjacent arguments in its complement).

⁶ Koopman and Sportiche argue for an additional segment of VP (Vmax), in whose specifier subjects are generated:

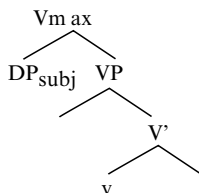

Koopman and Sportiche further differentiate case-marking of specifiers of I (in SVO languages) and case-marking of complements of I (in VSO languages) by claiming that in the former case, I is a “case assigner by agreement” (that is, it triggers not only nominative case marking on subjects in its specifier, but verbal agreement with the subject as well), and in the latter case, I is a “case assigner by government” (that is, it assigns structural case but does not trigger agreement). They note that while SVO languages such as English and the Romance languages always show subject person/number agreement on verbs, VSO languages such as Irish and Welsh do not.⁷ As further evidence for the contrast between case assignment by agreement and case assignment by government, they note that Standard Arabic, which allows both SVO and VSO word order, only marks subject person/number agreement on verbs when the subject appears preverbally; otherwise the verb receives default (third-person) agreement regardless of the person and number features of the subject.⁸ In short, when subjects raise to spec, IP, they trigger person/number marking on verbs; when subjects remain below I and receive case-marking by head-government, no agreement is triggered.

They also assert that case assignment by government is restricted by locality. In cases in which other projections intervene between I and the subject inside VP, the subject is required to raise to a higher position in order to be adjacent to I. For instance, in Welsh, a VSO language, subjects surface immediately after verbs in sentences with clausal negation:

17. Agorodd y dynion ddim y drws
 opened-3s the men not the door
 “The men didn’t open the door”
 (Koopman and Sportiche 1991, p. 234)

They assume that clausal negation originates in a negative projection (NegP) between I and VP:

⁷ Pamela Munro (p.c.) points out that a number of VSO languages, such as Garifuna and Mayan, do have subject agreement on verbs, while a number of SVO languages, such as Wolof and Chinese, lack subject agreement on verbs.

⁸ A similar correlation between preverbal subjects and verbal agreement occurs in Macuilianguis Zapotec, which employs predominantly SVO word order and disallows subject agreement when postverbal subjects appear. However, Macuilianguis Zapotec also allows certain preverbal subjects to appear without agreement markers on the following verb (Foreman 1999).

18.

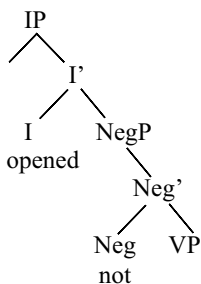

If the verb “opened” raised past “not” in Neg to I (they presume that negation does not block movement of the verb), leaving the subject in its base-generated position within VP, the wrong word order would result: “opened not the men the door” would surface rather than “opened the men not the door”. Thus, they argue, the subject “the men” must raise out from VP to spec, NegP in order to receive case-marking from I.

There is strong evidence, however, that strict adjacency to the raised verb is not responsible for VSO word order in SLQZ. For one thing, SLQZ allows preverbal (focused) subjects as well as postverbal ones, and fronting of the subject does not trigger agreement on the verb:

19. B-da`uh Gye`eihlly gueht
 perf-eat Mike tortilla
 “Mike ate the tortilla”

20. Gye`eihlly b-da`uh gueht
 Mike perf-eat tortilla
 “MIKE ate the tortilla”

It could be argued, however, that since preverbal subjects in SLQZ are always focused or topicalized, the raising of subjects to preverbal position is A-bar movement rather than A movement, and thus does not involve the triggering of agreement.

A stronger piece of evidence against head-government of subjects comes from the behavior of subjects and verbs when certain postverbal markers appear. SLQZ has a large inventory of postverbal markers that attach (at least phonologically) to the right edge of verb stems, but precede lexical subjects and pronominal subject clitics.

In the following examples, two such markers appear: *-da`a`n* “a lot”, and *al* “already”. *Al* “already” may appear either clause-initially, before the verb (21), or postverbally, between the verb and the subject or pronominal subject clitic (22):

21. Al b-da'uhw-daàa'n-rëng bx:àady
 already perf-eat-a.lot-3p.prox. grasshopper
 "They already ate a lot of grasshoppers"
22. B-da'uhw-daàa'n-al-rëng bx:àady
 perf-eat-a.lot-already-3p.prox. grasshopper
 "They already ate a lot of grasshoppers"

In these cases either one or two adverbial markers intervene between the verb and the subject clitic. In (22), it appears that the verb "eat" and the adverbial "a lot" have raised around "already", leaving the subject clitic stranded. If this is the case, there is no longer strict adjacency between the verb and the subject. Nevertheless, the sentence is still licit, contrary to Koopman and Sportiche's predictions.

Another postverbal marker is the clitic *-ga'*, which can be roughly glossed as "instead". *-Ga'* may cliticize to either verbs or nouns; nominals marked by *-ga'* obligatorily appear preverbally (as seen by the ungrammaticality of (24):

23. Lia Oliieb-*ga'* b-gyàa'a
 Ms. Olivia-instead perf-dance
 "OLIVIA danced instead (of someone else)"
24. *B-gyàa'ah Lia Oliieb-*ga'*
 perf-dance Ms. Olivia-instead
 "OLIVIA danced instead (of someone else)"
25. B-gyàa'ah-*ga'* Lia Oliieb
 perf-dance-instead Ms. Olivia
 "Olivia DANCED instead (of doing something else/while waiting for something else to happen)"

In cases when *-ga'* modifies a verb, preverbal subjects are blocked:

26. *Lia Oliieb b-gyàa'ah-*ga'*
 Ms. Olivia perf-dance-instead
 "Olivia DANCED instead (of doing something else)"

This suggests that *-ga'* occupies a fixed position above the normal landing position for verbs, and the constituent it modifies must raise to its left (presumably to pass through the projection *-ga'* occupies for feature-checking purposes). The preverbal subject is blocked in (24) because raising of the verb past *-ga'* either places the verb above the preverbal focus projection or otherwise blocks access to it.⁹

⁹ The exact position and nature of the projection headed by *-ga'* is not crucial for the current discussion, and I have deliberately set aside these issues here. See Chapter 4 for an analysis of the syntax of another clitic that behaves similarly

If verbs modified by *-ga'* do indeed raise out of their normal landing position (assuming that they normally land in the Tense projection), postverbal subjects would be blocked under Koopman and Sportiche's account, since the verb does not end up in a position from which it can directly head-govern the subject, and *-ga'* intervenes between the verb and the subject. Instead, contra the predictions of their account, postverbal subjects are required in these constructions and preverbal subjects are banned, as seen in (24). In short, SLQZ does allow postverbal subjects even when other syntactic material appears between the verb and the subject.

It must be mentioned, however, that only a limited inventory of constituents may appear between verbs and subjects in SLQZ (parenthetical expressions and temporal adverbial phrases, for instance, may not appear in this position). Chapters 3 and 4 examine the inventory of functional projections in detail, and motivate some of the co-occurrence restrictions between them.

2.2.6 Summary

This section has outlined some of the previous proposals for deriving VSO word order, and shown that none of these adequately accounts for the behavior of SLQZ. Since SLQZ shows clear subject/object asymmetries, it cannot be presumed to have a flat, tripartite structure. Since SLQZ allows VSO word order even when overt complementizers are present, SLQZ verbs cannot be presumed to raise to C. Since SLQZ preverbal subject constructions don't trigger subject agreement on verbs, and SLQZ allows some adverbial elements to intervene between sentence-initial verbs and subjects, it can't be the case that subjects remain in situ in VP and are head-governed by verbs in I. Finally, since SLQZ verbs and their aspectual/tense-marking prefixes behave as syntactic units, SLQZ verbs cannot be construed as remaining in situ while subjects generated elsewhere lower into VP. Chapter 3 presents an alternate proposal that more adequately accounts for the morphological and word-order constraints of SLQZ.

2.3 The Antisymmetry of Syntax (1994): An Overview

Now I turn to the theoretical framework that will motivate the rest of this work. The field of generative grammar is based on the notion that grammar is truly "universal" in that all language learners begin to acquire their languages with the same innately determined constraints on possible forms a language can take (Chomsky 1957). It has been

(the modal marker-*zhya'*) and its use as a diagnostic for the ordering of preverbal functional projections.

widely assumed that the range of possible differences among the world's languages can be derived from choices in how a number of parameters set by someone acquiring a given language. Since SVO and VSO languages have prepositions and VOS and SOV languages have postpositions, for example, it is often assumed that learners of these two respective groups of languages must learn at an early age that their languages are either “left branching” or “right branching” — that is, complements of locational markers or other pre-/postpositions may appear either before these elements (in left-branching, postpositional languages) or after them (in right-branching, prepositional languages). For instance, the structures for the phrase “by car” in English, a prepositional language, and Japanese, a postpositional language, have traditionally been assumed to be base-generated as follows:

27. English:

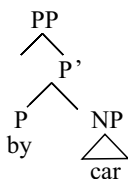

28. Japanese:

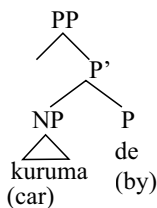

Directionality, then, has been one of the parameters generally assumed to be allowable within the range of possible human languages.

In his 1992 paper and 1994 monograph, Kayne proposes that all languages are underlyingly derived from identical structures. This assumption forces an even stricter set of constraints on what is “universal” about universal grammar. He suggests that all languages, regardless of surface word order, branch to the right and are “antisymmetric”: that is, word order is directly correlated to structural hierarchy. Thus, elements that are higher in a tree structure necessarily precede elements that are lower; high constituents appear on the left of the tree structure and lower ones on the right. This proposal is represented formally as The Linear Correspondence Axiom (LCA), shown below:

29. $D(A)$ is a linear ordering of T (Kayne 1994, p. 6)

Here, T is a set of terminal elements, D is the dominance relation among non-terminal elements, A is a set of asymmetrically c -commanding pairs of non-terminals, and $D(A)$ is the set of terminals dominated by A . In other words, all tree structures are binary branching, and all pairs of non-terminals are antisymmetric (one c -commands the other, but not vice versa). Thus, the linear ordering of terminal elements is a direct reflection of the structural hierarchy of the elements that dominate them: a constituent that precedes another in a sentence is necessarily higher than it in the tree structure.

The LCA, then, renders illicit a number of structures previously assumed to be allowable. For instance, VSO languages were argued to be derived from ternary-branching structures such as the following, repeated from Section 2.2.1:

30.

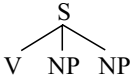

This structure violates that LCA by (1) not being binary branching and (2) allowing all its terminals (V and the two NPs) to mutually c -command each other. In short, this structure shows no correlation between linear order and structural hierarchy; all its terminals are equally high in the tree structure.

There is empirical, as well as theoretical evidence ruling out structures such as (30) and suggesting the correctness of the LCA. If VSO languages were indeed derived from flat structures such as (30), there should be no subject-object asymmetries in VSO languages, since subjects and objects would mutually c -command each other. As seen in section 2.2.1, however, this proves not to be the case: a number of unrelated VSO languages, including SLQZ, show patterns indicating that subjects are indeed higher than objects (for instance, examples 5 and 6 in this chapter).

Apparent counterexamples to the LCA, such as the existence of postpositions, can be accounted for by positing movement of a constituent from a lower position (such as the complement position of an underlying preposition) to a higher position (such as a position above this “preposition”, which, because of this reordering of its complement, now surfaces as a postposition). For instance, Japanese postpositional structures such as that in (28) can now be seen as derived from structures like those of English prepositional structures as follows:

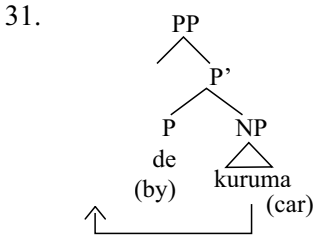

Kayne argues that suggestive evidence for movement of complements of “postpositions” in languages such as Japanese comes from the fact that postpositions agree with their complements in a number of left-branching languages, but no such agreement occurs in languages with prepositions. If agreement is assumed to be a reflex of specifier-head agreement (per Chomsky 1992, among others), the presence of agreement in postpositional structures supports Kayne's view that complements of locational markers have raised to the specifier of PP in these structures.

In short, Kayne argues, differences in word order across the world's languages are not the result of different underlying structures or directionality, but of different movement strategies constrained by the requirement that languages be fully antisymmetric. Thus, if Kayne is correct, directionality per se can no longer be considered a parameter selected by different languages.

Kayne argues that this proposal has a number of desirable empirical consequences. X-bar theory, usually considered a primitive of linguistic theory, for example, can be derived by the requirement that word order and structural hierarchy be strictly correlated. Other general constraints, previously considered either stipulations or simply descriptions of general crosslinguistic phenomena, can also be accounted for under his proposal. Since some of the mechanics of his proposal are assumed (or modified) later in this work, I provide a brief description of them here.

The basic structural relationship that defines the hierarchical and linear ordering of elements under the principles of antisymmetry is c-command. This relationship has long been considered essential in the definition of hierarchical relations such as those involved in binding theory (Reinhart 1981). Exact definitions of c-command vary (Reinhart 1981, Aoun and Sportiche 1983) but the most basic definition of the notion is as follows:

32. A c-commands B iff neither A nor B dominate each other and the first branching node above A dominates B.

This definition makes no assumptions about the categorical status of A, B and the node above A that dominates B. A consequence of this definition is that c-command relations may be bidirectional and structures

may be symmetric. For instance, in a structure such as (33) both A and B c-command each other:

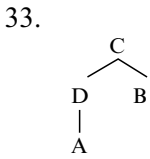

The possibility of bidirectional c-command is problematic for the theory of antisymmetry. If linear ordering and hierarchical order are strictly correlated, and if hierarchical order is defined by c-command relations, then a structure such as the one above, coupled with the preceding definition of c-command, would wrongly predict both that B precedes A (since B c-commands A) and A precedes B (since A c-commands B). Clearly, these two conditions cannot be true simultaneously.

Kayne handles this problem by positing a stricter definition of c-command:

34. X c-commands Y iff X and Y *are categories* [Kayne's italics] and X excludes Y and every category that dominates X dominates Y. (Kayne 1994, p. 18)

Unless otherwise noted, this is the definition of c-command that I will assume in the rest of this work. In this definition, categories are assumed to be full projections (that is, topmost XP nodes). Thus, segments of categories (that is, X-bars or other non-terminal nodes under an XP) may not c-command other elements.¹⁰ Kayne crucially assumes that dominance of one projection (XP) over another (YP) requires that all non-terminal segments of a dominating projection XP dominate YP. The crucial distinction Kayne makes in this definition then, is that only categories (full XP projections) are visible to c-command relations.

¹⁰ Kayne, however, assumes that intermediate nodes between terminals and the top nodes of categories are XPs, rather than X-bars, as follows:

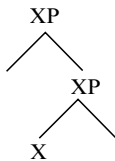

Because nothing in my analysis depends on this distinction, and because X' is a more familiar notation for position, I will continue to use X' in this work.

35.

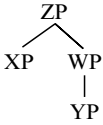

For instance, in (35), XP, WP, ZP, and YP are categories. ZP dominates XP, WP, and YP. XP c-commands YP since ZP and all other categories higher than XP also dominate YP. For the same reasons, WP c-commands XP. YP, however, does not c-command XP because the first category dominating YP (WP) does not dominate XP.

In his definition of c-command, Kayne adopts Chomsky's (1986) definition of exclusion: X excludes Y iff no segment of X dominates Y. The condition that the c-commander and c-commandee exclude each other derives the "branching node" condition in older c-command definitions: since WP does not exclude YP in (35), for instance, WP cannot be construed as c-commanding YP, even though WP and YP are both categories and every category dominating WP dominates YP.

The requirement that tree structures be completely antisymmetric, with dominance and linear ordering determined by c-command relations as defined in (34), results in a highly constrained set of possible structures that is still capable of allowing a wide variety of possible word orderings. Because only full XPs may c-command and be c-commanded, per Kayne's definition, segments are invisible to calculation of c-command relations, phrasal projections are limited to specifiers (phrasal projections adjoined to the left of other phrasal projections: YP in Figure (36) is the specifier of XP), heads (terminals of phrasal projections, such as X in Figure (36)), and complements (phrasal projections generated as sisters to heads, which appear to the right of heads: ZP in Figure (36), for instance, is the complement of XP):

36.

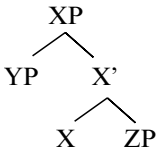

Thus, multiple specifier structures, such as multiple adjunctions to the same projection, are ruled out.

37

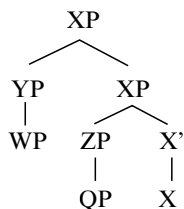

Structures such as (37) are illicit because the two XPs are not separate categories (that is, they are not independent phrasal projections), but are rather segments of the same category XP (just as X' is also a segment of XP, the lower XP is a segment of the higher XP). Recall from the discussion of (34) that segments are defined as “X-bars or *other non-terminal nodes* under an XP”. Since the lower XP node is not the topmost non-terminal node of XP, it is considered a segment, rather than a distinct category. YP in (37) asymmetrically c-commands QP, so by the LCA (which links structural hierarchy to linear precedence) YP must precede QP. However, ZP above also c-commands WP, thus wrongly predicting that ZP (and QP, which it dominates) precedes WP. Thus, YP and ZP fail to be defined in their linear or hierarchical relation to one another.

A notable consequence of this is that adjuncts are now assumed to be the sole specifiers of the projections they appear in. (Thus, YP in (36) can be considered an adjunct of XP.) Another consequence is that specifiers may c-command out of their projections since they are not dominated by them. For instance, in Figure (38) below, ZP c-commands Y: ZP excludes YP (it does not dominate any segment of YP) and every category that dominates ZP dominates YP. (YP does not dominate ZP in Kayne’s framework because only the top node of YP contains ZP; Y', the other nonterminal node of YP does not dominate ZP).

38.

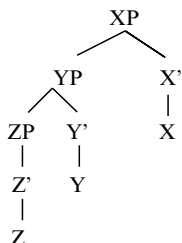

Thus, Kayne’s definition of c-command correctly posits ZP to c-command and precede Y, and YP to c-command and precede X. Evidence that specifiers c-command out of their projections comes from data such as the following:

39. Nobody's articles ever get published fast enough (Kayne 1994, p. 24)

Negative polarity items such as *ever* are standardly assumed to be licensed by *c*-commanding negative constituents. Here, *ever* is licensed by *nobody*, which Kayne assumes to be the specifier of the projection headed by *articles*.

The possibility of structures such as (38) allows apparent cases of multiple adjunction by allowing adjuncts to appear as specifiers of other specifiers: in (38), YP, the specifier of XP, could be an adjunct of XP, and ZP, the specifier of YP, could be an adjunct of YP. For instance, Kayne posits structures such as (38) for cases of from multiple clitic adjunction in French:

40. Jean vous le donnera
 Jean to.you it will.give
 "Jean will give it to you" (from Kayne 1994, p. 20)

In this sentence, two clitics, *vous* "to you", and *le* "it", appear to be adjoined to the same head, *donnera* "will give". Kayne suggests that the verb *donnera* "will give" be posited as the head of XP, *le* "it" will be the head of YP, and *vous* "to you" will be the head of ZP in (38). This is shown below in (41):

- 41.

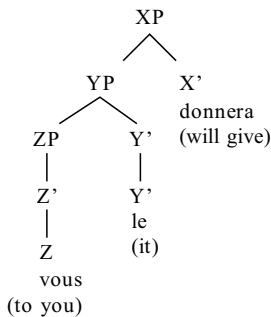

Thus, all adjunction must now be seen as movement to specifier positions.

The precise mechanics of Kayne's theory are still a matter of debate (see, for example Koopman (1996) for a potential modification of these structural constraints). Some of Kayne's basic assumptions and strategies for maintaining antisymmetry, and their applications to SLQZ, are examined in further detail in the following chapters.

3 The Syntax of Verb Raising in SLQZ: Arguments for VP Raising

3.1 Overview

This chapter examines in further detail the verbal morphology of SLQZ, and begins to investigate how SLQZ verbal morphology is reflected in syntactic structure. I argue for a radical approach to verb movement in SLQZ: I demonstrate that the VP, not the V, raises, and that tense, aspect and agreement features are checked by VP raising through the specifiers of the relevant functional projections, rather than V-raising through their heads. Similar strategies have also been independently proposed for other, unrelated verb-initial languages (Chung 1998; Massam (2000); Rackowski and Travis (2000), Davis and Demirdache (1998)).

In brief, the structure I propose is as follows: arguments are generated VP-internally, and raise out of VP into their respective agreement projections:

1.

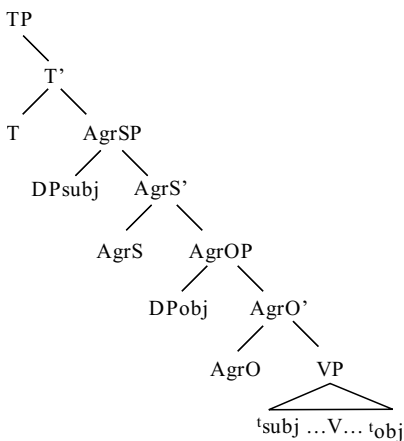

Then the VP itself, containing the traces of its arguments, raises to spec, TP:

2.

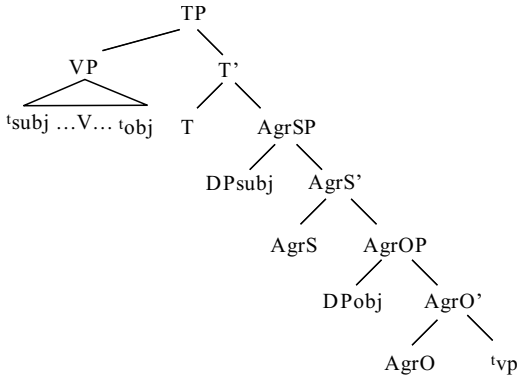

(The internal structure of VP is described in detail below.)

This movement accounts not only for the verbal morphology of SLQZ, but also for its VSO word order.

I first show that SLQZ inflected verb complexes cannot be derived under a standard head-raising analysis, then elaborate upon the VP-raising analysis shown above. I then show how this analysis accounts for both the distribution and structure of verb forms in SLQZ. I also examine evidence that VSO word order and morphological constraints in a number of other languages may likewise be derived from VP-raising.

This analysis has a number of consequences for the grammar of SLQZ overall; this chapter describes how some of SLQZ's other notable features fall out directly as a result of this analysis.

3.2 SLQZ Verbal Morphology Revisited: Problems for Verbal Head Movement

In Chapter 1, the verbal morphology of SLQZ is described in detail: verb stems are obligatorily preceded by aspect markers, and followed by subject agreement clitics if their subjects are pronominal. Other morphological material may affix to either the left edge of the verb stem (after the aspect marker) or to the right edge of the verb stem (before the subject agreement clitic). Third-person singular pronominal objects may be expressed as clitics at the rightmost edge of the verb complex.

Thus, a template for a fully inflected verb in SLQZ (repeated from Chapter 1) would be as follows:

ASP(directional)(causative)VERB(sec.rt)(sec.rt)(adv.)(adv.)(adv.)(SAM)
(Obj.clitic)

Deriving a syntactic structure for this configuration, however, raises a number of problems. Adopting the standard assumptions that verbs are inflected through head-movement and morphemes are affixed in the order in which they occur in the syntax (following Baker's (1985) Mirror Principle), and (per Kayne (1994)) raised heads can only adjoin to the left of higher heads they raise to, morphemes on the left edge of a verbal complex formed by incorporation must be base-generated above those on the right.

This works in the following way: an incorporated complex of morphemes zyx is derived from the base-generated structure xyz :

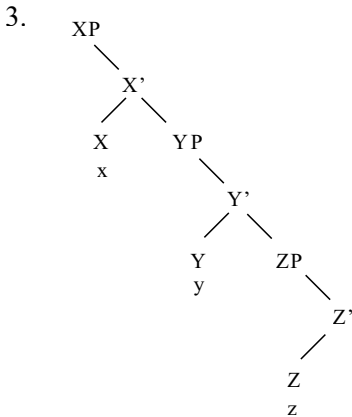

Under the assumptions of the Mirror Principle, the lexical head z adjoins to the left of the head y (right adjunction is banned by antisymmetry):

4.

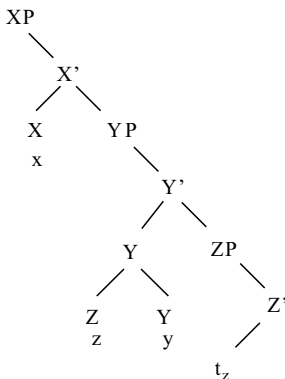

The complex head zy then adjoins to the left of x :

5.

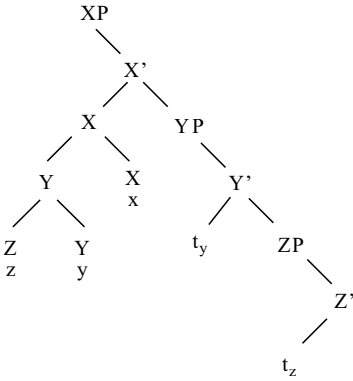

Thus, morphemes in incorporated structures surface in the reverse order of their base-generated syntactic order.

The head-movement incorporation strategies just outlined were posited in part to account for the order of verbal morphemes in polysynthetic languages, which show obvious noun incorporation. Baker (1996) notes that polysynthetic languages across a range of language families show a strong parallelism in the ordering of their verbal morphemes: incorporated objects appear to the left of the verb stem, while tense/aspect markers appear to the right of the verb stem. An example of typical verbal morpheme ordering is seen in the following Mohawk sentence:

6. Ra'-wárh-a-k-s-kwe'
 MsS-meat-Ø-eat-hab-past
 "He used to eat meat"

(Mohawk: Baker 1996, p. 30)

In short, verbal morphemes in polysynthetic languages are ordered from left to right in exactly the reverse order as the generally accepted order of their base-generated positions: it is generally assumed that tense and aspect are licensed preverbally high in the tree structure (near the left edge) while objects are generated below (and after) the verb. The head-movement strategy previously outlined, then, allows this ordering of morphemes to be derived from a syntactic structure parallel to that attested in other language types.

This strategy, however, proves problematic for SLQZ (and, as I also show, a number of other VSO languages). Under the assumption that SLQZ verbal inflection is derived by head-movement, a structure consistent with the verbal template above (repeated below) would thus look something like this (projections that do not appear obligatorily are in parentheses):

7. ASP(directional)(causative)VERB(sec.rt)(sec.rt)(adv.)(adv.)(adv.)(SAM)
(Obj.clitic)

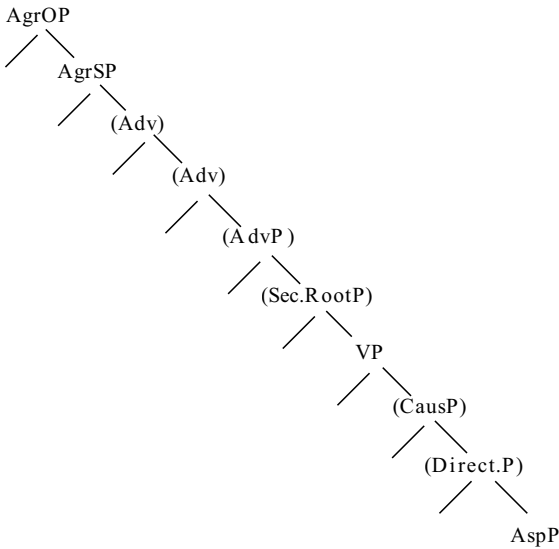

Such a structure is clearly undesirable. First, placement of AgrO above AgrS is virtually unattested in linguistic theory, as is the idea that aspect/tense inflection is generated below the root verb, and it is unwise to assume that SLQZ can differ from other languages in such crucial ways. Also, it has been convincingly argued that in verbs with causative alternates (such as *run* in *Mike runs* versus causative *run* in *Mike ran the horse around the track*), the projection serving the causative function is directly above, not below the root verb (cf. Hale and Keyser 1993, Kural 1996, Chomsky 1995, among others).

Another option is that heads may adjoin to either the left or right edge of the verbal head as it raises up through the structure. Thus, the Aspect and Causative heads would adjoin to the left edge of the verb, and the others adjoin to the right edge. Such an approach is problematic for several reasons. First, it clearly violates the spirit (if not the letter) of the Mirror Principle: since the ordering of morphemes on the verb would only partially reflect their ordering in the tree structure, there would be no way of telling whether the left-adjoining morphemes are generated higher or lower than the right-adjoining ones. Second, it clearly violates Kayne's (1994) Linear Correspondence Axiom (LCA) by forming structures that branch in more than one direction. Although it has been suggested (Potter 1995) that languages may select the directionality in which adjoined heads surface at PF (some languages spell out adjoined heads at the left edges of phonological structures at PF,

others to the right), it is not possible under Potter's theory for a language to spell out material in both directions simultaneously.

A final, and potentially simplest, option would be to adopt a non-ordered feature-checking approach, consistent with Chomsky 1995: contra Baker, Kayne, etc., features checked by movement may be checked in any order, and feature-checking is not constrained by the physical ordering of morphemes. This would be the best option to adopt if it were the case that inflected verbs in SLQZ behaved consistently like heads in all contexts. There is, however, clear evidence that this is not the case. Some of this evidence is presented in the following section.

3.2.1 Evidence Against Head-Movement of SLQZ Verbs

There are a number of syntactic contexts in SLQZ in which verbs and XPs may appear interchangeably. Below I discuss three of these: modification by second-position adverbial clitics, constituent negation, and verbal compound formation.

Adverbial Clitic Placement

One piece of evidence against the head status of inflected SLQZ verbs comes from the distribution of second-position adverbial clitics: they may modify DPs as well as inflected verbs. The clitic *-zhya'*, used to express epistemic modality, for instance, may affix to either verbs (as seen in (8) below) or to DPs, as seen in (9).

8. N-u'-zhya'-rëng Lohs Aa'nngl
 neut-exist-might-3p.prox Los Angeles
 'They might be in Los Angeles (temporarily)'
 [e.g., it might be the case that they are in Los Angeles]

9. Lohs Aa'nngl-zhya' n-u'-rëng
 Los Angeles-might neut-exist-3p.prox
 'They might be in LOS ANGELES '
 [e.g., Los Angeles is where they might be/live]

In the following examples, the adverbial clitic *-ga'*, 'instead/for the time being' also attaches to both DPs and verbs:

10. Lia Oliieb-ga' b-gyàa'ah
Ms. Olivia-*instead* perf-dance
“OLIVIA danced *instead* (of someone else)”
11. B-gyàa'ah-ga' Lia Oliieb
perf-dance-*instead* Ms. Olivia
“Olivia DANCED *instead* (of doing something else/
while waiting for something else to happen)”

The preceding four examples show that the scope of the adverb (and thus the interpretation of the sentence) varies according to the constituent it is affixed to. In (8), where the modal clitic *-zhya'* appears attached to the sentence-initial verb “exist”, the modality takes scope over the entire event denoted by the VP (the event of being in Los Angeles is a possible state of affairs). When *-zhya'* “might” is attached to sentence-initial “Los Angeles” (in (9)), the modality takes scope only over “Los Angeles” (e.g., “Los Angeles might be the place where they are”).

The differing placement of *-ga'* “*instead/for the time being*” in (10) and (11) results in similar contrasts. In (11), for example, *-ga'* “*instead*” takes scope over the nominal “Ms. Olivia”, indicating that Olivia was the participant selected to dance *instead* of someone else. In (10), *-ga'* takes scope over the verb “dance”, with the meaning that Olivia chose dancing *instead* of another activity. In other words, *-ga'* serves to distinguish the constituent it modifies as an object or activity selected out of a set of possible alternatives.

These examples suggest that adverbial clitics occupy a fixed syntactic position, and that constituents that they modify raise to their left. A syntactic, rather than morphological, account of cliticization is supported by the fact that the appearance of any of these clitics in a sentence will constrain possible word orders. Arguments modified by certain adverbial clitics (such as *-ga'* “*instead/for the time being*”), for instance, must appear preverbally, rather than in their canonical postverbal argument positions:

12. Lia Oliieb-ga' b-gyàa'ah
Ms. Olivia-*instead* perf-dance
“OLIVIA danced *instead* (of someone else)”
13. *B-gyàa'ah Lia Oliieb-ga'
perf-dance Ms. Olivia-*instead*
“OLIVIA danced *instead* (of someone else)”

This suggests that constituents modified by such adverbial clitics are required to raise to some higher position (above the position in which verbs without adverbial clitics ordinarily surface) in order to license the relation between themselves and the adverbial. Thus, at least some adverbial clitics must be generated (or have their features licensed) above

the position where inflected verbs generally surface at PF, which I assume to be TP.¹

This possibility is supported by other word-order constraints imposed on sentences whose verbs appear with certain adverbial clitics. Verbs cliticized by *-zhya'*, for instance, disallow preverbal subjects:

14. B-da'uhw-al-ru-zhya' Gye'eihlly bx:àady
 perf-eat-already-more-might Mike grasshopper
 "Mike might have already eaten more grasshoppers"
15. *Gye'eihlly b-da'uhw-al-ru-zhya' bx:àady
 Mike perf-eat-already-more-might grasshopper
 "Mike might have already eaten more grasshoppers"

SLQZ subjects may appear fairly freely in preverbal position when given contrastive focus readings. I thus assume the existence of a high (pre-TP) functional projection for syntactic focus movement (FocP); further evidence for this will be outlined in Chapter 4. The fact that arguments may not appear preverbally in constructions such as (15) suggests that the verb has raised to the left of the adverbial clitic and landed in a position at least as high as the preverbal focus projection.

Thus, there is strong evidence that at least some adverbial clitics force the raising of constituents they modify. As seen above, either DPs or inflected verbs may be targeted for movement. The parallel constraints on both types of constituent suggest that the syntactic processes they must undergo must also be parallel: thus, either inflected verbs must be treated as XPs, or other phrasal constituents treated as heads.

I will assume for the moment that the class of adverbial clitics that force movement of the constituents they modify are generated as heads of specific functional projections. A constituent modified by an adverbial suffix such as *-ga* "instead" (such as "Ms. Olivia" in (12), for instance) raises to the specifier of the projection occupied by *-ga'*, thus licensing its relation with the adverbial by specifier-head agreement:

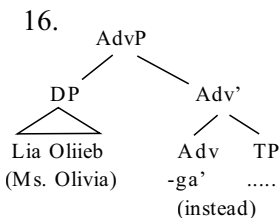

This movement results in the modified DP or verb surfacing to the left of the adverbial suffix. The fact that both DPs and verbs appear in the

¹ The idea that adverbs are generated in their own functional projections is explored in detail by Cinque (1998).

same structure with the same syntactic effects (both trigger the same constraint against preverbal focus) suggests that they undergo the same kind of movement. This suggests, then, that SLQZ verbs may undergo the same movement as XPs such as DPs, and supports the view that SLQZ verbs are indeed VPs.

Identical Negation Patterns for Verbs and XPs

Further evidence against the head status of inflected verbs comes from their distribution and behavior under negation. SLQZ negation is most commonly expressed by two discontinuous morphemes; negated constituents appear between these two elements. Standard clausal negation in SLQZ, for instance, consists of a clause-initial negative morpheme *cě'ity* followed by the negated verb and the morpheme *-dya'* (which I leave un-glossed for the moment) then the subject or pronominal subject agreement marker:

17. *Cě'ity ny-àa'izy-dya'* Gye'eihlly Li'eb
 neg subj-beat-dya' Mike Felipe
 "Mike didn't hit Felipe"

Under standard assumptions about clausal negation (Pollock 1989, Zanuttini 1991, among others), negated verbs raise into the head of NegP. In cases of standard clausal negation in SLQZ, this does not seem problematic.

A head-movement account of clausal negation, however, fails to account for other common negation structures in SLQZ. Contrastively focused verbs, for instance, may be negated with the negative element *a'ti'* instead of *cě'ity*:

18. *A'ti' gw-àa'izy-dya'* Gye'eihlly Li'eb, b-cuhni'-ëng Li'eb
 neg perf-hit-dya' Mike Felipe perf-kick-3s.prox Felipe
 "Mike didn't HIT Felipe, he KICKED Felipe."

It could be claimed that the only difference between (17), the negated sentence with *cě'ity*, and (18), the sentence with negated contrastive focus (with *a'ti'*) is that *a'ti'* appears instead of *cě'ity*. The verb, along with the negative element *-dya'*, raises by head-movement to the head of NegP in both constructions.

This, however, poses problems for other constructions with the negative morpheme *a'ti'*. *A'ti'* is most commonly used to negate adjectival and nominal predicates, as well as contrastively focused constituents and prepositional phrases. In these constructions, *a'ti'* precedes, and *-dya'* follows, the negated constituent:

19. A'ti' Sann Luu'c-dya' gw-èeh Pa'amm
 neg San Lucas-dya' perf-go Pam
 "Pam didn't go to SAN LUCAS (but rather somewhere else)"
 (DP)
20. A'ti' cuann tenedoor-dya' b-da'uw Gye'eihlly gueht
 neg with fork dya' perf-eat Mike tortilla
 "Mike didn't eat tortillas with a fork"
 (PP)
21. A'ti' bùu'nny zyùall-dya' n-àa Gye'eihlly
 neg man tall -dya' neut-be Mike
 "Mike isn't a tall man"
 (DP/NP)

Since proper names (such as *Sann Luu'c* "San Lucas") are presumably DPs, rather than Ns or Ds, the idea that any material that appears between *a'ti'* and *dya'* is a head is problematic. The appearance of clearly phrasal elements such as *cuann tenedoor* "with a fork" between *a'ti'* and *dya'* is further evidence against the idea that *a'ti'* constructions are derived by head-movement of negated constituents into NegP. Equally problematic is the possibility of allowing either heads or XPs to participate in this construction. The fact that inflected verbs pattern with clearly non-head-like constituents under focus negation indicates that they should be treated as XPs, rather than heads. (Detailed syntactic structures for SLQZ negative constructions will be proposed in Chapter 4.)

One could logically assume, then, that the same type of movement takes place in all cases of *a'ti'* negation: either head movement or XP movement to a specifier position. Thus, as with the adverbial suffixation cases outlined previously, either inflected verbs behave like XPs and raise to specifier positions, or XPs such as the PPs and DPs above are treated like heads in the syntax and undergo head-movement. I will adopt the first option, and show that it accounts for not only the word order and morpheme ordering facts of SLQZ, but of other VSO languages as well. The latter option was explored by Carnie (1995). I will return to his proposal, as well as an alternate account for the data he presents, in the appendix to this chapter.

There are also morphological arguments against treating SLQZ verbs as heads. The most obvious argument against it is that it fails to account for the ordering of SLQZ verbal morphemes; as I will show in Section 2.2.2, the XP-raising analysis does account for this.

Absence of Head-Movement Effects

Another piece of morphological evidence against the head status of phrasal units in SLQZ is the absence of head-movement/incorporation effects in the formation of SLQZ words. The word *ryu'làa'z* "likes",

for instance, consists of two morphemes: *ryu'uh* “enters” and *lààa'z* “heart”. If it were the case that verbs were heads, *ryu'lààa'z* would have to be posited to be the result of incorporation, with the head *ryu'* “enters” raising and left-adjointing to the head *lààa'z* “heart”:

22.

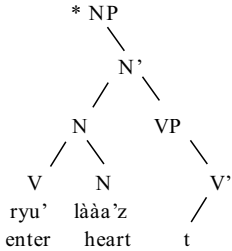

Such incorporation, however, would wrongly form a nominal, rather than a verbal, element since *lààa'z*, the head of the compound, is a noun.

Another option would be to assume that incorporated heads may adjoin to the right, rather than the left, of the higher head. In this case, *lààa'z* “heart” would incorporate into *ryu'* “enter”, thus forming a compound properly headed by a verb:

23.

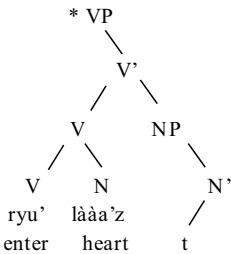

Structures such as (23) violate the LCA by allowing multidirectional branching. I thus assume that such structures are illicit. Furthermore, even if right adjunction were a legitimate option, it would be highly inconsistent with the strongly left-branching, head-initial architecture of SLQZ.

Munro, Lopez et al (1999) list a number of SLQZ verbal expressions that clearly exemplify this problem. One such expression is *ruhnybyùùzh* “tears into little pieces”. This verb is composed of two morphemes: *ruhny* “make/do” and *byùùzh* “meat pieces on chicharrones”. Thus, it is clearly derived from an expression with *byùùzh* as the syntactic object of “make”.

Compounds such as *ryu'làà'a'z* and *ruhnybyùùzh* are treated as single grammatical units with fixed, non-compositional meanings in SLQZ. Subjects and subject agreement markers follow both morphemes (and may not appear between the morphemes), and their composite morphemes cannot be broken apart by syntactic processes such as adverbial cliticization. Second-position clitics such as *-zhya'* “might”, for instance, may not break up compounds containing *làà'a'z*:

24. B-yannlàà'a'z-zhyá' Gye'eihlly n-gyaà'a'nn Gye'eihlly bèe'cw
 perf-forget-might Mike subj-feed Mike dog
 “Mike might have forgotten to feed the dog”

25. *B-yann-zhyá'-làà'a'z Gye'eihlly n-gyaà'a'n
 perf-forget-might Mike subj-feed
 “Mike might have forgotten

Gye'eihlly bèe'cw
 Mike dog
 to feed the dog”²

Adverbial suffixes, if present, must appear after the secondary root *làà'a'z*, as seen in the grammaticality contrast between (24) and (25). Thus, compounds with *làà'a'z* are treated as single grammatical units.

The inviolability of these compounds, however, can be accounted for without treating them as heads. It is well known, for instance, that English phrasal idioms such as “kick the bucket” also resist syntactic extraction:

26. *What did Mike kick? (on idiomatic reading)

27. *Mike's bucket was kicked by the Mafia.

Nevertheless, “kick the bucket” has the internal structure of an ordinary VP, and behaves like a standard VP in the structures in which it appears. Di Sciullo and Williams (1988) reconcile the semantic irregularity and grammatical regularity of phrasal idioms by calling them “listed syntactic units”: they are constructed according to normal rules of syntax, but are given special status as “listed” lexical items (that is, items whose meanings are noncompositional, and thus must be given their own listings in the lexicon). This analysis can be extended to verbal compounds such as *ryu'làà'a'z* in SLQZ.

² SLQZ, like other Zapotec languages, regularly allows apparent Principle C violations such the binding of “Mike” by “Mike” in these examples. The second, bound copy is not referential and behaves semantically like a bound variable. This phenomenon is described in detail in Lee 2003.

This raises the issue of why nominal expressions such as *làà'z* and *byiùzh* in the compounds shown above are not forced to raise out of VP into agreement projections, as do other nominals generated within VP. A possibility is that these expressions are blocked from raising out of VP for the same reasons “bucket” cannot be extracted from the idiomatic VP “kick the bucket”: since “bucket” is not referential in this context, it cannot be questioned or manipulated in the same way as a normal syntactic object. The fact that “bucket” may not be modified for number agreement (“*Careless drivers kick their buckets every day”) suggests that it may not even raise to AgrOP, where such features are checked, in the contexts in which it appears. If this is the case, then *làà'z* “heart” in *ryu'làà'z* and *byiùzh* “meat pieces on chicharrones” in *ruhnybyiùzh* may likewise be posited to be nonreferential: since there are no actual hearts or meat fragments involved in either of the verbal expressions described above.³

To sum up, there is no way to derive the correct form of multimorphemic verb roots such as *ryu'làà'z* “like” by head movement. The fact that even compound words show the morpheme ordering of phrases strongly argues against the possibility that they might be heads. This, along with the syntactic distribution and other morphological features of SLQZ verbs, support the idea that SLQZ verbs are XPs rather than heads.

3.3 VP-Raising and Constituent Structure in SLQZ

The previous sections showed why no workable clause structure for SLQZ could be derived if inflected verbs were posited as heads: they appear interchangeably with nominal and prepositional phrases in a number of syntactic constructions, and their morphological structure cannot be derived by head movement. This section will propose and show an actual basic tree structure for SLQZ and show how it accounts for the seemingly irregular distribution and form of inflected verbs.

Such a structure must meet two criteria: first, for learnability reasons, it must not diverge radically from the basic structures posited for other languages. In other words, a child learning SLQZ as a first language must acquire not a radically different tree structure, but simply a different mechanism for deriving the correct position of the verb. Second, this structure must also be able to account for, in a principled way, all the possible variations of verbal form caused by verbal suffixes.

The basic structure I propose is as follows:

³ I leave aside the interesting question of why idioms such as “take advantage of” do allow syntactic manipulation (e.g. “Advantage was taken of John’s weakness”).

28.

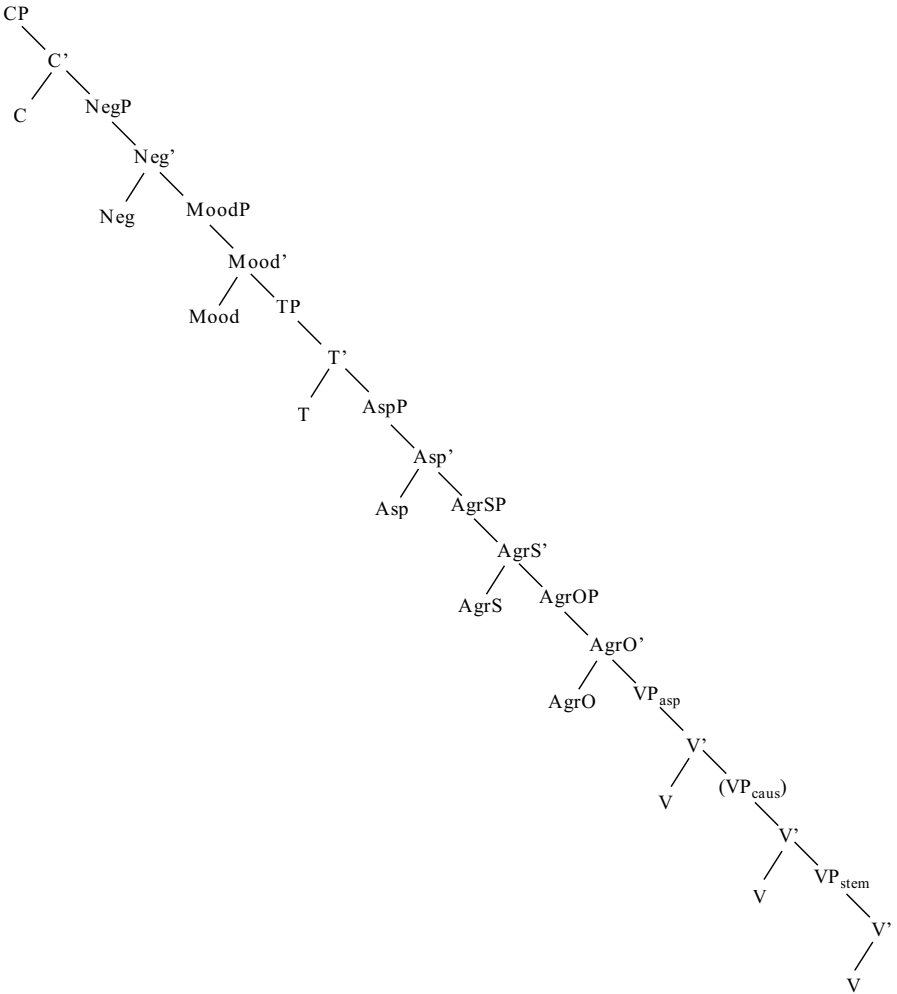

where VP_{asp} is headed by a light verb that serves to mark tense, aspect, and occasionally mood (this to be justified and further explained below); VP_{caus} is headed by a causative verb marker (cf. Hale and Keyser 1993, Kural 1996, Chomsky 1995) when the verb is causative/transitive, and VP_{stem} is headed by the verb stem itself. (As previously noted,

there are a number of other projections that may appear below VP_{asp} , inside the verbal complex, but these are omitted for the preceding tree for expositional simplicity. There is also evidence for a number of projections above NegP, rather than a single position CP (consistent with proposals by Rizzi 1996, among others). Detailed evidence for split CP projections will be given in the next chapter.

Thus, the inflected verb that raises to TP is the set of VP shells dominated by VP_{asp} . Subjects and objects, which are generated within the VPs, raise out to AgrSP and AgrOP, respectively. The VP, containing the traces of these arguments, then raises through the specifier of AspP (where aspectual features are checked) to the specifier of TP, where tense features of the verb are checked.

In the following subsections, I will account for the ordering of functional projections proposed above. First, I will address the internal structure of the VP complex itself; then I will discuss the ordering of the remaining clausal projections.

3.3.1 Projections within the VP Complex

The Tense/Aspect Marker

The leftmost morpheme in the SLQZ verbal complex is the obligatory marker for tense, aspect, and mood. If, as argued, inflected verbs in SLQZ are raised VPs rather than raised Vs, then the only way to derive aspect markers on the left edge of the verb is to generate them there as part of a higher VP shell. This higher VP projection, then, must be that in which the actual “aspect markers” of SLQZ are generated: VP_{asp} in the tree above. (VP_{asp} is not to be confused with AspP, which is a separate, higher projection in which VP_{asp} is licensed.) The light verb in VP_{asp} has aspectual features that are checked by movement of the VP complex dominated by VP_{asp} through AspP and (depending on its form) tense features checked by movement through TP.

The internal structure of a simple VP consisting of a verbal stem and aspect marker, then, is as follows (abstracting away from the base-generated positions of extracted arguments):

29.

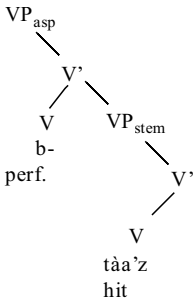

This VP complex dominated by VP_{asp} , then, is what raises through $AspP$ and TP to appear clause-initially in structures such as the following:

30. B- tàa'z Gye'eihlly Li'eb
 perf-hit Mike Felipe
 "Mike hit Felipe"

The representation of aspect markers as verbs is not unprecedented. Demirdache and Uribe-Exteberria (1997) note that Basque progressives are formed with the verb "be engaged in":

31. Anaia leihoa apur-tze-n ari da
 Anaia window break-NOM-in engage AUX (be)
 "Anaia is engaged in breaking the window/Anaia is breaking the window"
 (Basque: Demirdache and Uribe-Exteberria 1997, p. 5)

The verbal status of the constituent expressing Progressive aspect in Basque is also consistent with their proposal that Aspect is predicative as well as locative.⁴

⁴ Suggestive evidence for the verbal status of SLQZ aspect markers comes from the homophony between certain aspect markers and verbs with similar meanings. The progressive marker *ca-*, for instance, closely resembles the word *caa*, which can be used either as the question word "where" or as a verb meaning "to hang" or "to be spread around over". A diachronic relation between these elements would be consistent with the proposal that progressive markers in a number of languages are historically derived from expressions of spatial location (Bybee, et al (1994), cited in Demirdache and Uribe-Exteberria 1997.)

Directional Markers

The directional markers, reduced forms of *riè'd* “come” and *rihah* “go”, appear after the tense/aspect markers and before the causative marker and verb stem. Thus, in verbal complexes with directional markers, the tense/aspect marker appears on “come” and “go”, rather than on the verbal stem itself. I assume that directional markers are generated as heads of their own verbal projections, above the verbal stem and causative marker, but below the tense/aspect marker. *Ridta'uh* “comes and eats”, for instance, has the following internal structure:

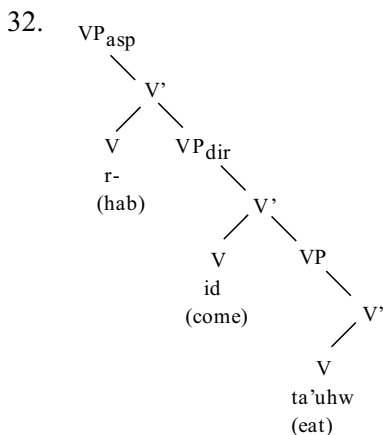

In the following examples from ML, for instance, the habitual aspect marker *r-* appears before the directional marker, rather than directly on the verb stem:

33. r-canzàa
hab-wander.around
“wanders around”
34. r-i-canzàa
hab-go-wander.around
“goes and wanders around”
35. r-a'uhw
hab-eat
“eats”
36. r-id-ta'uhw
hab-come-eat
“comes and eats”

This patterning is superficially reminiscent of what Jaeggli and Hyams (1993) dubbed ‘aspectual’ “come” and “go” constructions in English. These constructions, like the SLQZ examples above, involve “come” and “go” taking verbal complements without any tense inflection of their own:

37. Come talk to me

38. Whenever I have time, I go watch a movie

SLQZ directional markers, however, are far less constrained syntactically and semantically than English aspectual “come” and “go”. For one, SLQZ directional markers may take a full range of tense/aspect prefixes, while aspectual “come” and “go” may not show any tense or agreement marking:

39. *You came talk to him yesterday

Unlike their English counterparts, SLQZ directional markers are not restricted to constructions with volitional subjects:

40. *Pieces of driftwood come wash up on the shore

41. Calii loo r-id-dicah nnyihs?
where at hab-come-appear water?
“Where does the water come out?” (ML 1999)

Jaeggli and Hyams suggest that aspectual “come” and “go” assign secondary theta roles to their subjects, thus leading to the constraint that only volitional subjects may appear in these constructions. This is clearly not the case in SLQZ: ML list a number of other commonly used verb forms with directional markers in which no agentivity is required of the subject (as seen above). This suggests that SLQZ “come” and “go” are interpreted as purely directional, and do not assign secondary theta roles to the subjects of the verbs they modify.

I leave aside a more detailed analysis of these constructions for future research.

The Causative Projection

The morphological causative marker surfaces directly to the left of the verbal stem. As described in the previous chapter, this marker takes a number of forms: it either appears as a distinct morpheme (often *s-* or *z-*) or as fortition of a lenis initial stem consonant. Examples (42) and (43)

show the addition of the causative morpheme *z-* on the left edge of the verb stem; examples (44) and (45) show causation marked by fortition of the stem-initial lenis consonant *zh:-* to *x:-* :

42. *r-ihnnih*
hab-get.light
 “gets light” (of the sky, before dawn)
43. *r-z-ihnnih*
hab-caus-get.light
 “turns on (a light)”
44. *r-zh:ùu’nny*
hab-run
 “runs”
45. *r-x:ùu’nny*
hab-caus.run
 “makes (something) run”

Many SLQZ morphological causatives are transitive alternates of monadic predicates best translated in English as passives.⁵

46.

<u>Non-causative</u>	<u>Causative</u>
<i>rihihw</i> “gets ground up”	<i>rziuhw</i> “grinds up, pulverizes”
<i>rzh:ììì</i> “is milked, is squeezed, is wrung”	<i>rx:ììì</i> “milks, squeezes, wrings”
<i>ryèè’t</i> “is called”	<i>rzèè’t</i> “mentions, calls”

Following a number of accounts (Hale and Keyser 1992, Kural 1996, Baker 1996 among others), I posit this causative marker to be the head of a VP shell that takes the verbal stem as its complement. Because causative markers appear after aspect and directional markers, I assume they head a VP shell below VP_{asp} and VP_{dir}, but above VP_{stem}:

⁵ Munro (course lectures, 1997) notes, however, that the semantic relation between causative/non-causative verb forms in SLQZ is often idiosyncratic and not strictly causative, even though the addition of an additional argument to thematic grid is generally involved: for instance the morphological causative alternate to *rguèè’ll* “gets fast, does fast” is *rsaguèè’ll* “is kind enough to, does a favor and”.

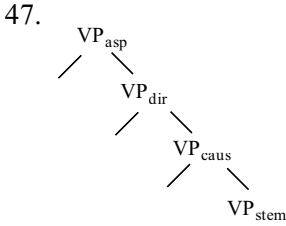

SLQZ also has a periphrastic causative construction formed with the verb “make”:

48. Laarëng b-èèi’ny-rëng b-zh:ùu’ny caba’i
 3p.prox perf-make-3p.prox perf-run horse
 “They made the horse run”

The periphrastic and morphological causative constructions show contrasts in meaning as well as form. While periphrastic causative constructions express the idea of indirect causation, their morphological causative counterparts imply a stronger causative relationship between the causer and causee. This contrast appears in the following examples: the first an example of a periphrastic causative construction, the second its morphological causative version:

49. B-èèi’ny Li’eb [y-gyàa’ah Gye’eihlly]
 perf-make Felipe irr-dance Mike
 “Felipe made Mike dance”
50. B-z-yàa’ah Li’eb Gye’eihlly
 perf-cause-dance Felipe Mike
 “Felipe made Mike dance/ Felipe danced Mike around”

The first sentence can mean Felipe enabled Mike to dance by paying his fees for a dance contest, for instance. The second can only mean that Felipe physically dragged Mike onto the dance floor and danced him around. I will call the first reading the “indirect” causative reading, and the second the “direct” causative reading.

The correlation between indirect and direct causative readings and periphrastic and morphological causative constructions has been noted crosslinguistically. Kural (1996) notes that such correlations hold in Hungarian and Turkish, for example. I assume, following Kural, that periphrastic causative constructions in SLQZ are biclausal (as indicated by the brackets in (49)), and morphological causative constructions are monoclausal. A detailed examination of causative constructions in SLQZ is outlined in Casillas (1995).

Secondary Roots

SLQZ verbs may contain bound morphemes that appear on the right edge of the verbal stem, but before adverbial suffixes and subject agreement markers. These markers, which differ from other postverbal suffixes in that they attach only to verbs and not to other constituents, have been labelled “secondary roots” by Munro (course lectures, 1997).

Secondary roots, as their name implies, also differ from adverbial suffixes in that their presence is obligatory in certain lexical entries: certain secondary roots are thus not productive. A number of SLQZ verbs (mostly denoting propositional attitudes and emotional states), for instance, are formed with the secondary root *lààa’z* “heart”, whose use is not productive:

51. Some verbs formed with the secondary root *lààa’z*

ryu’lààa’z “likes”
(*ryu’uh* “enters” + *lààa’z* “heart”)

rinèelààa’z “keeps in mind”
(*rinèe* “takes”+ *lààa’z* “heart”)

rza’clààa’z “wants”
(?? + *lààa’z* “heart”)

rzalààa’z “remembers, is aware of”
(?? + *lààa’z* “heart”)

rnnàa’azlààa’z “does a good deed for”
(*rnnàa’az* “grabs,touches”+ *lààa’z* “heart”)

rni’ii’bylààa’z “worries, is concerned”
(*rni’ii’by* “moves”+*lààa’z* “heart”)

rgwinylààa’z “feels sad, feels sorrowful”
(?? + *lààa’z* “heart”)

In some cases, the first part of these compounds can be identified as an independent verb: the first morpheme in *rni’ii’bylààa’z* “worries” is the verb *rni’ii’by* “moves, makes a movement”, the first morpheme in *rinèelààa’z* “keeps in mind” is the verb *rinèe* “takes, takes along”; and the first morpheme in *ryu’lààa’z* “likes” is the phrasal (phonologically shortened) form of the verb *ryu’uh* “enters”.

In other cases, the semantic contribution of the first morpheme of the compound is less clear: ML’s dictionary lists no independent entry for *rgwiny* (nor anything that looks enough like it to be a possible source for it), for instance.

Another example of a secondary root is *rrei'cy/ arrei'cy* “upside down”.

52. Z-èei'by-arrei'cy-ëng
 def-hang-upside.down-3s.prox
 “It’s hanging upside down” (ML, p.281)

This is an example of a secondary root which, unlike *làà'z*, may be used productively. This also shows that secondary roots include a number of grammatical categories: they may be nominal (as is *làà'z*) or prepositional (as is *rrei'cy/ arrei'cy*)

I thus consider verbs containing secondary roots to be verbal compound words.

Secondary roots also appear to be syntactically, as well as semantically, bound to the verb theme: they raise along with the verb theme in contexts involving verb movement, such as negation. In (53), the verb “forget”, formed with the secondary root *-làà'z* “heart”, behaves as a single unit that undergoes movement under clausal negation:

53. Cë'ity n-yaannlàà'z-dya' Gye'eihlly
 neg subj-forget-dya' Mike
 “Mike didn’t forget
- n-gyaan Gye'eihlly bèe'cw
 subj-feed Mike dog
 to feed the dog”

I will assume that secondary roots are generated in XP shells below the main verb: this forces them to raise when the higher VP raises.

The Comitative Applicative Marker *nèe*

Another commonly used secondary root is the comitative applicative marker *nèe*, which may also appear on the right edge of the verb. *Nèe* differs from secondary roots such as *làà'z* in that its use is productive. *Nèe* increases the valence of the verb by allowing the presence of an additional argument, generally an additional subject or, less commonly, a direct object participant. For this reason, I gloss it “with”. Below are some typical examples of its usage (examples provided by Munro (p.c.)):

54. B-da'uw-nèe Li'eb Gye'eihlly gueht
 perf-eat-with Felipe Mike tortilla
 “Felipe ate tortillas with Mike”

55. B-da'uw-nèe Li'eb bzyààa' gueht
 perf-eat-with Felipe bean tortilla
 "Felipe ate tortillas with beans"

As these examples show, the added argument appears immediately after the main subject: the added subject "Mike" appears immediately after the subject "Felipe" in (54), and the added object "beans" likewise appears immediately after the subject (but before the direct object "tortillas") in (55). The fact that arguments introduced by *-nèe*, regardless of their own thematic status as added subjects or objects, occupy a fixed position between subjects and direct objects suggests the existence of a specific licensing projection for comitative arguments. This projection must be distinct from the position in which indirect objects appear, since indirect objects obligatorily surface after direct objects, not before them:

56. B-dëihdy Gye'eihlly bx:àady Li'eb
 perf-give Mike grasshoppers Felipe
 "Mike gave the grasshoppers to Felipe"
57. *B-dëihdy Gye'eihlly Li'eb bx:àady
 perf-give Mike Felipe grasshoppers
 "Mike gave the grasshoppers to Felipe"

The latter example can only have the reading "Mike gave Felipe to the grasshoppers".

Additional indirect objects generally may not be introduced with *nèe*:

58. B-dëihdy Gye'eihlly bx:àady Li'eb
 perf-give Mike grasshoppers Felipe
 "Mike gave the grasshoppers to Felipe"
59. *B-dëihdy-nèe Gye'eihlly bx:àady Li'eb Lia Oliieb
 perf-give-with Mike grasshoppers Felipe Ms.Olivia
 "Mike gave the grasshoppers to Felipe and Olivia"

(While (59) is ungrammatical with the interpretation shown, it is allowable if "Felipe" is construed as an added subject participant. An allowable interpretation, then, would be "Mike, along with Felipe, gave the grasshoppers to Olivia").

The only exceptions to this constraint are certain unergative verbs such as "talk" and "sing", which allow indirect objects (such as "Olivia" in (60) and "Felipe" in (61)) to be introduced by *nèe* :

60. Al w-nii-nèe Gye'eihlly Lia Oliieb
 already perf-talk-with Mike Ms. Olivia
 "Mike already talked to Olivia"

61. B-ii'ldy-nèe Gye'eihlly Li'eb
 perf-sing-with Mike Felipe
 "Mike sang to Felipe"

Interestingly, the latter example could mean either "Mike sang to Felipe" (in which case Felipe is an observer of the singing) or "Mike sang with Felipe" (in which case Felipe is a participant in the singing). This is reminiscent of the similar ambiguity of *speak with* in English: "Mike already spoke with Olivia" could mean either Mike and Olivia participated equally in the conversation or that Mike merely told Olivia something and she only listened.

Nèe appears after any other secondary roots that may appear (such as *lààa'z* "heart" and *rrei'cy* "upside down" in the examples below), but before adverbial suffixes such as the modal suffix *-zhya'* "might":

62. R-gàa'lààa'z-nèe'-ng Gye'eihlly
 hab-gets.caught.heart-with-3s.prox Mike
 "He sighs with Mike" (P. Munro, p.c.)
63. Z-uurrei'cy-ni-a' Gye'eihlly
 def-stand.upside-down-with-1s Mike
 I'm standing upside-down with Mike (P. Munro, p.c.)
64. Z-auw-nèe-zhya' Gye'eihlly Li'eb gueht
 def-eat-with-might Mike Felipe tortilla
 "Mike might eat tortillas with Felipe"

Although *nèe'* superficially resembles applicative markers in other languages (that is, it is a verbal affix that licenses the presence of an additional argument), its usage is confined to comitative contexts: it cannot, for example, introduce benefactive or instrumental arguments, as do applicative markers in other languages:

65. W-nnààaz Gye'eihlly bx:àady cuann gyihx
 perf-catch Mike grasshopper with net
 "Mike caught grasshoppers with a net"
66. *W-nààa'z-nèe Gye'eihlly gy:ihx bx:àady
 pef-catch-with Mike net grasshopper
 "Mike caught grasshoppers with a net"

The constraint against applied benefactive/instrumental arguments licensed by *nèe* is also reflected in the possible interpretation of the following:

67. Xi b-da'uhw-nèe-u' gueht?
 what perf-eat-with-2s.inf tortilla
 "What did you eat tortillas with?"

This can only be interpreted as "what other food did you eat besides tortillas?". It could not be followed up felicitously with an answer such as "with a fork", for example.

Nèe may also appear sentence initially. In this context, it has the meaning "too", and takes scope over the immediately following nominal argument, which appears preverbally:

68. Nèe Li'eb b-da'uhw bx:àady
 too Felipe perf-eat grasshopper
 "FELIPE ate grasshoppers, too" (along with other people)
69. Nèe bx:àady b-da'uhw Li'eb
 too grasshopper perf-eat Felipe
 "Felipe ate GRASSHOPPERS too" (along with eating other things)

Thus, apart from the cases with "sing" and "talk", *nèe* does not contribute additional thematic roles to a sentence. Rather, it expresses the presence of additional entities that appear in parallel with already licensed arguments.

Now I address the question of the syntactic status of *nèe*. Since it raises along with verbs it modifies (as seen in (64), where it raises along with the verb to the left of the modal clitic *zhya'*) it must form a syntactic unit with the verb. The fact that *nèe* raises along with the verb it modifies is also seen in negation constructions, where the verb and *nèe* appear between the two morphemes used to express clausal negation:

70. B-gyàa'a-nèe Lia Oliieb Gye'eihlly pehr cë'ity
 perf-dance-with Ms. Olivia Mike but neg
 "Olivia danced with Mike, but she didn't
- n-gyàa'a-nèe-dy-ëng Li'eb
 subj-dance-with-neg-3s.prox Felipe
 dance with Felipe"

This suggests that *nèe*, like the secondary roots, is generated as a complement of the verbal stem:

71.

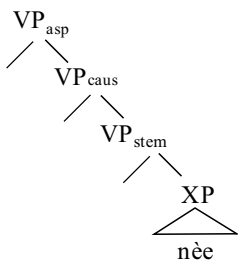

I will set aside the question of the exact categorial status of *nèe*. Applicative markers have been analyzed as incorporated prepositions (Baker 1988, den Dikken 1993) or as higher predicates that take the VP and its arguments as its own arguments (Baker 1996, Pearson 1997, Nyonyani 1996). Since these analyses were mostly motivated by the syntactic and semantic behavior of benefactive, rather than comitative, constructions, it is probable that they may not be relevant for the analysis of *nèe*.

If *nèe* is indeed generated as a complement of the verbal stem, this fact would have a number of consequences for the internal structure of the rest of the VP. For one, it raises the question (which I have not yet addressed specifically) of exactly where in the extended VP structure subjects and objects are generated. If the projection headed by *nèe* is generated as a complement of the verbal stem, then objects of transitive verbs—which have standardly been assumed to be generated as complements of verbs—would have to be generated elsewhere.

Consider, for example, a sentence with *nèe* and a transitive verb:

72. B-da'uhw-nèe Gye'eihlly ra mnii'iny gueht
 perf-eat-with Mike plur child tortilla
 "Mike ate tortillas with the children"

Here, there are three arguments ("Mike", "the children" and "tortillas") that must be generated in VP, and that must raise out of VP to their respective agreement projections before the VP itself raises to TP. Thus, a possible structure for the VP "eat with" in (72) might be as follows:

73.

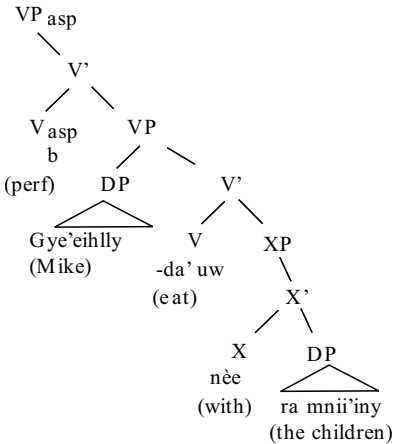

The problem is clear: the subject, “Mike”, can be assumed to be generated as the specifier of the VP headed by “eat”. The comitative phrase headed by *nèe* is generated as the complement of “eat”. This, however, leaves no logical place for the object, “tortillas”, to be generated. Although there are two empty specifier slots left in the tree (the specifiers of XP and VP_{asp}), neither would be a plausible place to generate the object: for one, the presence of *nèe* or an aspect marker does not entail that the sentence at hand will contain a direct object (since *nèe* may appear with intransitive verbs and aspect markers appear obligatorily in SLQZ). Constraints against generating arguments in random, non-selecting projections have been well motivated in linguistic literature: among these is the Uniformity of Theta Assignment Hypothesis (UTAH) (Baker 1988):

74. Identical thematic relationships between items are represented by identical structural relationships between those items at the level of D-structure.
(Baker 1988, p. 46)

Since direct objects are selected by the semantic requirements of the verb, it follows from the UTAH that all direct objects must be generated in the same structural relation with the verb. Clearly, projections that appear with all verbs (such as VP_{asp}) or those that appear only optionally, and with verbs of varied valences (such as the projection headed by *nèe*), do not meet this requirement.

Thus, direct objects, which are specifically selected by transitive verbs, must be generated within the VP headed by the transitive verb itself. If the optional comitative projection is generated as a complement of VP, as argued, this suggests that transitive verbs contain more layers of structure

than assumed so far, and one of the projections in this structure houses the direct object.

The idea that verbs, even those that appear monomorphemic, may be underlyingly constructed from multiple VP projections, has been motivated by both syntactic and semantic factors (Larson 1988, Hale and Keyser 1994, Kural 1996). Kural, for instance, posits the existence of “elementary predicates” (realized in the syntax as phonologically null verbs) with inchoative and causative functions: when combined with specific lexical items via incorporation, these predicates determine the valence and interpretation of the verb. For instance, the English verb “sink” may have either an inchoative, intransitive reading (as in “the boat sank”) or a transitive, causative reading (as in “the navy sank the boat”). The difference in meaning and argument structure between these forms results from the presence of phonologically null causative or inchoative predicates. Hale and Keyser likewise posit the existence of phonologically null verbal heads that contribute to the syntactic and semantic structure of verbs: one configuration that they propose is that transitive verbs consist of two embedded VPs, with the agent generated as the specifier of the higher (causative) VP and the theme (affected argument) as specifier of the lower VP:

75.

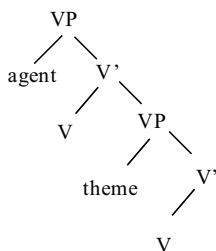

The verb itself raises through both VPs. (For instance, a verb that may surface in a structure such as (75), for instance, is “shelve” as in “Mike shelved the books”).

If we assume, then, that transitive verbs such as “eat” contain two embedded VPs (not counting VP_{asp}), then an additional position for the generation of direct objects emerges: the specifier of the lower VP. Thus, the base-generated structure for (72), “Mike ate tortillas with the children”, would be as follows:

76.

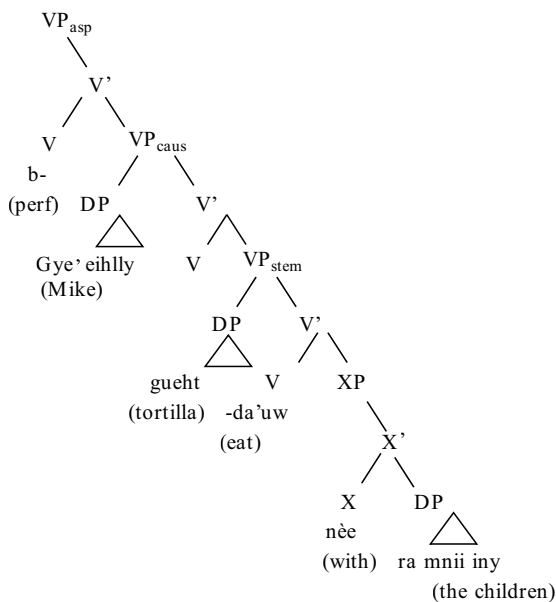

A possibility I will consider is that the VP shell in which subjects of transitive verbs are generated is the causative projection previously described. This would mean that all transitive verbs in SLQZ have active causative projections, even if they have no overt phonological expression. This possibility is consistent with that proposed by Hale and Keyser (1994).

This structure also suggests that the added argument is not coordinated directly with any of the other arguments: in (76), for instance, the added subject argument “the children” is not syntactically coordinated with the actual subject “Mike”. This idea is supported by the fact that both additional subjects and objects introduced by *nèe* surface in the same position between AgrSP and AgrOP, as seen in (54) and (55). The fact that this position (which I take to be an oblique case-licensing agreement projection) is not associated with any particular thematic role suggests that arguments that land there must be taken to be syntactically distinct from actual subjects and objects. (It could be argued that the exact thematic interpretation of arguments introduced by *nèe* is determined only by context.) The status of arguments introduced by *nèe*, then, could be considered roughly analogous to the status of optional agent/experiencer arguments introduced with “by-phrases” in English passives: while arguments introduced with “by” are interpreted as external arguments, they behave syntactically as oblique arguments, and differ semantically from typical external arguments in that their presence is purely optional.

Another issue raised by the structure in (76) is the base-generated position of the argument introduced by *nèe*: if all other arguments are generated as specifiers, why is the argument introduced by *nèe* generated as a complement? This can be justified by the behavior of preverbal *nèe* in examples such as (77), repeated from above: when fronted to preverbal position (and given the reading “too”), *nèe* always precedes the argument it introduces:

77. Nèe Li'eb b-da'uw bx:àady
 too Felipe perf-eat grasshopper
 “FELIPE ate grasshoppers, too” (along with other people)
78. *Li'eb nèe b-da'uw bx:àady
 Felipe too perf-eat grasshopper
 “FELIPE ate grasshoppers, too”

This suggests that *nèe* and the argument it introduces raise together as a unit. The fact that *nèe* is used in these contexts to introduce actual subjects and objects, rather than additional subject or object participants, suggests that *nèe* in these cases might be base-generated, along with the argument it precedes, in the specifier of one of the VP shells, rather than as an embedded complement of VP itself. For instance, in (76), the subject XP *nèe Li'eb* “Felipe too” may be generated in the specifier of VP_{caus}:

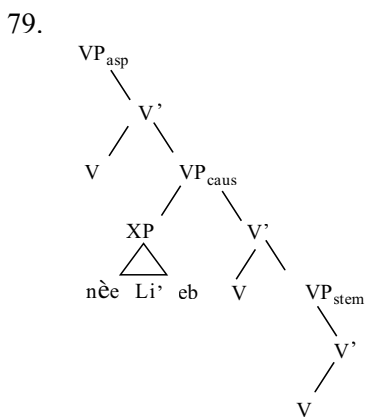

This in turn suggests that the projection headed by *nèe*, whatever it may be, is not a VP: the fact that *nèe* can be base-generated in argument positions, and that it is generated to the left of, rather than to the right of, the argument it introduces shows that it neither select arguments nor is generated in the syntax, like a normal VP.

3.3.2 Matrix Clause Projections

Now I turn to the hierarchical structure of the remainder of the matrix clause. I assume the basic relationship and ordering of Tense and Agreement proposed by Pollock (1987). Since negation is generally clause-initial in SLQZ, I assume NegP is high (per Zanuttini 1989, among others).

The placement of MoodP above TP is motivated by the fact that SLQZ modals appear directly above verbs, and no lexical material may intervene between modals and verbs:

80. Naa pahr g-àa'p Gye'eihlly muully pahr ch-ille'eh
 be for irr-have Mike money for irr-be.allowed
 "Mike has to have money in order

j-ieed Gye'eihlly nor'ty
 irr-come Mike north
 to come to the US"

81. *Naa pahr Gye'eihlly g-àa'p muully pahr ch-ille'eh
 be for Mike irr-have money for irr-be.allowed
 "Mike has to have money in order

j-ieed Gye'eihlly nor'ty
 irr-come Mike north
 to come to the US"

The placement of MoodP below NegP is motivated by the fact that there are a number of cases in which the modal interpretation of verbs is changed under negation (Lee 1996). Negation is clause-initial in SLQZ; thus, negated verbs must raise above their normal landing position (TP) in order to reach NegP. This change in modal interpretation under negation suggests that negated verbs must raise through MoodP in order to reach NegP, and in cases where modal features are active (such as when one of the three modal aspect markers is selected), the verb will receive a modal, rather than non-modal interpretation.

Verbs marked with Irrealis aspect, for instance, receive modal, rather than non-modal, interpretations under the standard clausal negation pattern exemplified in (17). Recall from Chapter 1 that verbs with Irrealis aspect may have either "non-modal" or "modal" interpretations: the non-modal interpretation, which surfaces when Irrealis-marked verbs appear in non-negated matrix clauses, is an indicative future reading, as shown below:

82. G-wàa'll-rëng li'ebr
 Irr-read-3p.prox books
 "They will read the books"

The “modal” reading of the Irrealis corresponds to some uses of the subjunctive in Romance languages, or the reading of infinitival complements of intensional verbs in English:

83. R-e’ihpy Lia Pa’amm làa’rëng g-wùà’ll-rëng li’ebr
 hab-tell Ms. Pam 3p.prox irr-read-3p.prox book
 “Pam told them to read the books”

The modal reading of Irrealis verbs is blocked in matrix clauses, which always get the indicative future reading.

This constraint is both semantically and syntactically motivated. Assuming Farkas’ (1995) model in which subjunctive clauses represent events that take place in sets of possible worlds introduced by an intensional predicate, then the presence of subjunctive-like readings of SLQZ Irrealis verbs in matrix clauses can be ruled out as redundant: matrix clause predicates are uttered in (and are presumed to be true in) the actual world of the speaker; they do not denote any possible worlds except the actual one.⁶ A matrix predicate such as *runs* in *John runs*, for example, can only be interpreted to mean that John is running in the actual world of the speaker and listeners, not that he is running in some hypothetical situation. If modal readings are triggered by the raising of verbs to a pre-TP Mood projection, then raising of verbs to Mood in matrix clauses can be ruled out for reasons of economy: the extra move is unnecessary for the meaning of the sentence.

The modal reading surfaces obligatorily when Irrealis-marked verbs undergo standard clausal negation, as seen below:

84. R-e’ihpy Lia Pa’amm làa’rëng
 hab-tell Ms. Pa’amm 3p.prox
 “Pam told them
- cë’ity** g-wùà’ll-(**dya**)-rëng li’ebr
 neg irr-read-(**dya**’)-3p.prox book
 not to read the books”

“Pam told them they will not read the books”

⁶ An obvious exception to this generalization is the case of conditional clauses (such as “If Mike comes early, tell him to wait for us”). Subjunctives are commonly licensed in conditional clauses crosslinguistically. In SLQZ, Irrealis verbs in clauses introduced by *bàllnah* “if” receive modal, rather than non-modal readings.

A distinct ordering of negative morphemes surfaces when Irrealis verbs with non-modal (indicative future) readings are negated:

85. **Cë'ity-dy-ënn** y-da'uhw-ënn gueht
 neg-dya'-1p irr-eat-1p tortilla
 "We won't eat tortillas"

In contrast to the standard clausal negation pattern exemplified in (17) and (84), when Irrealis verbs with future readings are negated, the morphemes used to express negation, *cë'ity* and *dya'*, appear adjacent to each other, rather than on either side of the verb. Another difference is that pronominal subject agreement markers appear twice: once on the verb, and once directly after *-dya'*. (In the previous example, for instance, the first-person-plural marker *-ënn* obligatorily appears twice.) Lexical subjects may also appear twice, but are only required after *-dya'*:

86. **Cë'ity-dya'** Jwaany g-a'uhw (Jwaany) gueht
 neg-dya' Juan irr-eat (Juan) tortilla
 "Juan won't eat tortillas"

A syntactic structure for this alternate negation pattern will be given shortly.

The need for this alternate structure is a direct result of the interaction between MoodP and NegP: as seen in (84), Irrealis verbs are interpreted with modal, rather than non-modal, readings when raised to NegP. This suggests, as previously argued, that MoodP intervenes between the standard landing spot of non-negated matrix verbs (TP) and NegP. The relevant movement of the VP through MoodP into NegP for (84), for example, is shown below:⁷

⁷ I posit the placement of the negative marker *-dya'* as the head of NegP for convenience here. Its exact position, and reasons for its position, will be discussed in Chapter 5.

87.

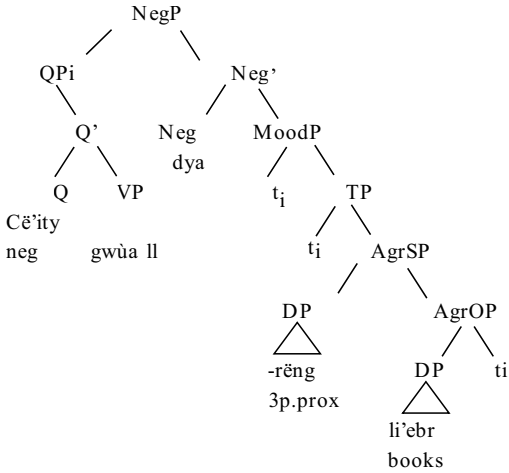

Thus, a syntactically distinct construction must come into play when a negated Irrealis verb is to preserve its non-modal (future) interpretation.

This raises the question of what exactly is the underlying structure of the negated future Irrealis pattern in (85) and (86). The structure can be accounted for as follows: Since the Irrealis verb itself cannot raise to **NegP** without passing through **MoodP** and thus receiving a modal interpretation, it remains in **TP**. The **CP** containing the Irrealis verb is embedded under a higher clause in which a covert existential predicate undergoes clausal negation. Thus, the underlying structure for a simple negated future Irrealis sentence such as (88), is as follows:

88. Cě'ity-dya' Gye'eihlly y-tò'o'oh ca'rr
 neg-dya' Mike irr-sell car
 "Mike won't sell the car"

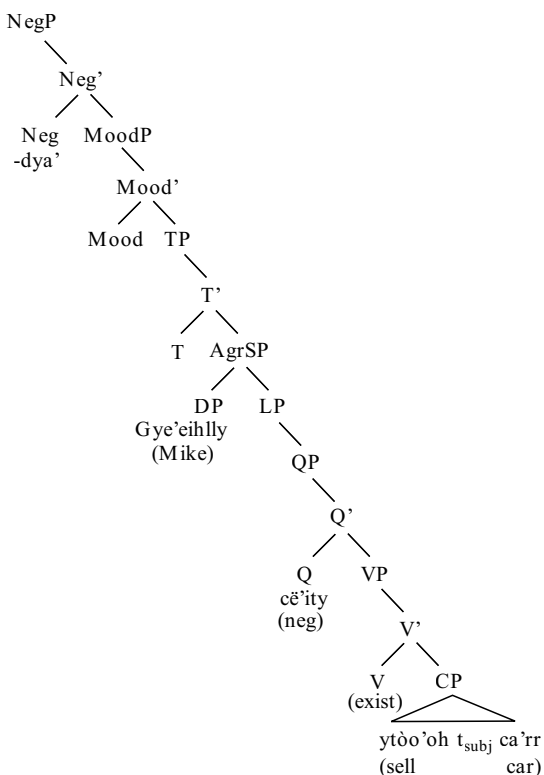

In this structure, the matrix clause verb is a covert existential predicate negated by *cě'ity*. The QP headed by *cě'ity*, with the covert existential as its complement, raises through TP and MoodP into spec, NegP. In order for this to occur without the complement of the covert existential (the embedded CP) raising to NegP as well, the embedded CP must raise to the position marked LP. A full explanation of this position and its functions will be presented in the following section.

The Irrealis VP remnant *y-tò'o'oh* “will sell” remains in spec, TP of the embedded clause. The embedded clause object “car” also remains in the embedded clause. The subject “Mike” raises out of the embedded clause into AgrSP of the matrix clause. This movement is motivated by two factors. First, since the covert existential verb is not a theta-assigner, it can act as a raising predicate. Second, Irrealis complements with modal readings behave as restructuring predicates in SLQZ; arguments generated within them may undergo long-distance movement normally disallowed from full complement clauses, such as focus

movement and A-movement of subjects out of the clause (see Lee 2003 for details.)

This structure for Irrealis negation not only enables the lower verb “sell” to remain in TP, it also gives the right semantic interpretation: the negated covert existential verb takes scope over the event denoted by the embedded clause, giving the reading “there exists no future event of Mike selling the car”.

The presence of a covert existential verb between the two negative markers in the higher clause is consistent with the fact that the verb *nu'uh* “exists” may be phonologically null in negated contexts:

89. N-u'-ng
neut-exist-3s.prox
“He exists”
90. Cë'ity n-u'-dy-ëng
neg neut-exist-dya'-3s.prox
“He doesn't exist”
91. Cë'ity -dy-ëng
neg-dya'-3s.prox
“He doesn't exist”

The Position of Embedded Clauses

This structure, however, raises a crucial question for the VP-movement proposal: if matrix predicate (the XP containing the silent existential verb) raises to spec, TP, then to spec, NegP, then how can the embedded clause with the Irrealis verb remain stranded below the two negative particles? Since it is a complement of the matrix verb, wouldn't it be forced to raise through the matrix clause to NegP as well?

The only way to derive the proper linear order of the sentence above under a VP-raising account is to raise the embedded CP out of the matrix VP to some higher projection (XP) before this VP raises to NegP:

- 92.
-
- ```

graph TD
 XP --> VP
 VP --> V_prime[V']
 V_prime --> V
 V_prime --> CP

```

While this may appear to be an ad hoc mechanism to save the VP-raising theory, it has independent theoretical motivation in earlier work on case and theta-role assignment of complement clauses (Emonds 1978,

Stowell 1981, among others). More recently, the raising of complement clauses to higher projections has been posited as a means of handling apparent cases of right-adjunction in a manner consistent with the principles of antisymmetry (Kayne 1997, Koopman (course lectures), Koopman and Szabolcsi 1998).

Stowell (1981) notes that while gerund clauses may appear as objects of prepositions and as subjects of complements of exceptional case-marking verbs, tensed clauses may not:

93. He blamed it [on [Bill's being too strict]]  
(Stowell 1981, p. 148)
94. \*He blamed it [on [that Bill was too strict]]  
(Stowell 1981, p.149)
95. I consider [ [John's having come home] to be fortunate]]  
(Stowell 1981, p. 149)
96. \*I consider [ [ that John came home] to be fortunate]]  
(Stowell 1981, p. 149)

Furthermore, tensed-clause complements may not appear directly after tensed verbs; they must appear after any other complements that appear:

97. Paul knew from experience [that the law was unfair]
98. ?\*Paul knew [that the law was unfair] from experience

He postulates that the ungrammaticality of (94), (96), and (98) can be attributed to the clashing requirements of case and theta-role assignment in these structures. He assumes the following requirement for theta role assignment (proposed in Chomsky 1981):

99. Theta-roles can only be assigned to A-chains that are headed by a position occupied by PRO or Case  
(Chomsky 1981, cited in Stowell 1981, p. 111)

Case assignment, however, is subject to a number of constraints, among them the following:

100. The Case Resistance Principle (CRP):  
Case may not be assigned to a category bearing a Case-assigning feature  
(Stowell 1981, p. 141)

Among the case-assigning categories is Tense. Thus, tensed clauses are among the categories subject to the CRP, and are thus blocked from appearing in case-marked positions.

The ungrammaticality of (94) and (96) can thus be accounted for. The tensed clause subjects of the embedded clauses cannot receive case under the CRP. Because they do not receive case (and are not PRO), however, they also fail to be properly theta-marked. The derivations thus crash. Likewise, (98) is ruled out by the CRP: the tensed-clause complement contains a case-assigning feature, but is in a position in which it may receive case-marking itself.

Stowell notes however, that there are a number of cases in which tensed clauses appear as subjects or complements of tensed verbs in apparent violation of the CRP:

101. [That Brian dyed his hair] proves nothing  
(Stowell 1981, p. 152)

102. Paul already knows [that Jim lives with his sister]  
(Stowell 1981, p. 159)

In the case of tensed-clause subjects, he suggests (adopting earlier ideas by Emonds (1976) and Koster (1978) that the tensed clause raises to a higher Topic position. This is supported by the fact that tensed clause subjects only appear in constructions in which topics can also appear, and are blocked in environments in which topics may not appear (such as inside relative clauses):

103. \*John's belief [[that you took the course] helped you] is unfounded  
(Stowell 1981, p. 153)

Stowell proposes that tensed clause complements of tensed verbs, such as that in (102) are also extraposed from their base (case-marked) position. He suggests (following Emonds 1976) that these extraposed clauses move rightward to a postverbal position to fulfill the CRP. This accounts for clause-final position of the tensed-clause complements in (102).

Thus, the idea that clausal complements must move to positions distinct from their base-generated positions is not new or theoretically unmotivated. Stowell's proposals can be easily updated to be consistent with Minimalist principles and antisymmetry constraints: most obviously, it must be assumed that tensed complement clauses raise leftward, not rightward, to fulfill the CRP. Also, the CRP itself can be restated in terms of feature licensing conditions: since case-assignment is now assumed to be licensed by spec/head agreement within AGR rather than by head-government by the verb stem, we must assume that tensed clause complements must appear in positions distinct from nominal complements because they cannot receive the case features assigned by

AGR. (Alternately, as suggested Hilda Koopman (p.c.), raised complement clauses may move through, but not remain in, case-marking agreement projections. In other words, clausal complements of tensed verbs raise to a licensing projection analogous to AGR, but that differs from the nominal agreement licensing projections in that it does not assign case.

This projection, which I will call L(icensing)P (LP) (following Koopman and Szabolczi 1997) must be fairly low in the matrix clause, since clausal complements follow subjects and objects of matrix verbs:

104. B-quilly      Li'eb Gye'eihlly [y-tò'oh Gye'eihlly ca'rr]  
 perf-persuade Felipe Mike      [irr-sell Mike car]  
 "Felipe persuaded Mike to sell the car"

I will tentatively assume that LP is directly below AgrOP.

### **More on Root Clause Constituent Order**

Now I return to the ordering of other projections within the matrix clause. From the preceding account of Irrealis future negation, it follows that MoodP must be above TP: if it were below TP, then Irrealis verbs (as well as verbs markers with other modal aspects) would always be required to pass through and activate MoodP, and would always have only one, modal interpretation. As seen in the first part of this chapter, this is not the case. The placement of the modal projection above TP is also consistent with Barbiers' (1995) proposal that Dutch modals with non-epistemic readings take IP (=TP) complements.

Rizzi (1996), among others, has proposed that CP, like IP, should be viewed as a set of separate functional projections, including Focus and Topic, among others. There is strong evidence to support this in SLQZ. I will return to the internal structure of CP in Chapter 4.

The embedding of AspP under TP was proposed in Lee 1996 (and independently, in greater detail, by Demirdache and Uribe-Exteberria (1997)). Both of these accounts motivate this structure by observing that Aspect describes the temporal status of an event within a certain time frame: for example, a sentence with past tense such as "He built a house" describes an event temporally ordered before the time of speech (or before some other contextually salient time). Aspect describes the status of an event within a time frame denoted by Tense: "He was building a house", for example, denotes an event that was in progress during a past time.

Demirdache and Uribe-Exteberria further suggest that Aspect is a predicate that selects a subpart of a time interval denoted by Tense: They define Progressive aspect, for example, as "a spatio/temporal predicate with the meaning of (with)in". Thus, the Progressive aspect in "He was building a house" selects a time frame within the past event of house-building. This time frame excludes the beginning and endpoints of

the event; thus, no implication can be made as to whether the house in the sentence was actually completed or not.

They further support this proposal with crosslinguistic and diachronic evidence. A number of languages (such as French, and Dutch, for instance), use prepositional phrases to express progressive events:

105. Jean est en train de courir  
 Jean is in along of running  
 “Jean is running”  
 (French: Demirdache and Uribe-Exteberria 1997, p. 5)

106. Ik ben het huis aan het bouwen  
 I am the house at the build  
 “I’m building the house”  
 (Dutch: Demirdache and Uribe-Exteberria 1997, p. 5)

Thus, there is crosslinguistic evidence that natural languages treat Aspect as having locative-like functions (Progressive Aspect, for instance, locates events within a given time frame) and in some cases, expresses Aspect in the grammar as a locative. This will be a crucial point in the derivation of Aspect in SLQZ.

Summing up, the structure for a simple sentence in SLQZ can be derived as follows: below is the base VP shell structure for (107):

107. B-z-yàa’ah Li’eb Gye’eihlly  
 perf-caus-dance Felipe Mike  
 “Felipe made Mike dance”

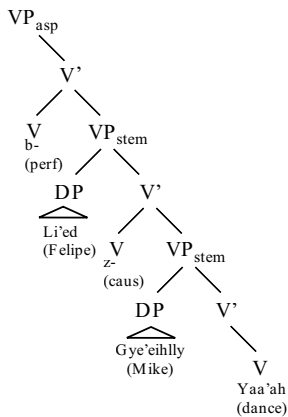



The subject, *Li'eb*, “Felipe”, base-generated in the specifier of the causative VP, raises to spec, AgrSP, and the object, *Gye'eihlly*, “Mike”, base-generated in the specifier of the VP stem, raises to spec, AgrOP. The entire VP complex then raises to the specifier of AspP, then to the specifier of TP:

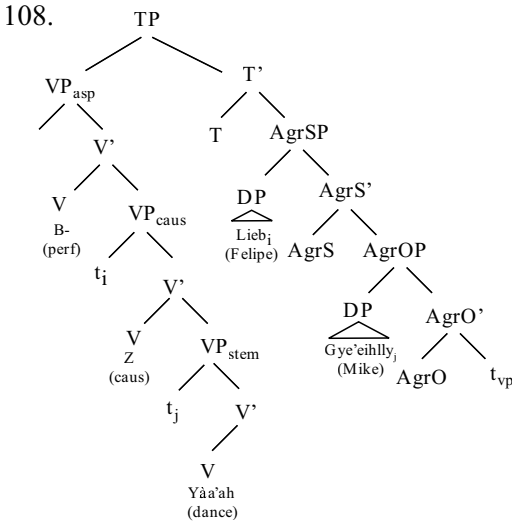

This model accounts for the linear ordering of morphemes in SLQZ verbs in a manner consistent with both the LCA and the Mirror Principle. VP-raising accounts have also been suggested as a means of deriving the word order of SOV languages such as Japanese in an antisymmetric framework (Nakajima 1996 and Pearson 1997), as well as the ordering of verb phrases in complex sentences in Hungarian (Koopman and Szabolcsi 1998). Like the account just proposed for SLQZ, these proposals assume that lexical material raises out of VP before VP-raising takes place. Nakajima’s account differs from the above in that it posits that the verbal head itself raises out of VP via head-movement, and the remnant VP contains the arguments, which remain in their theta-positions throughout the derivation. These accounts assume that the underlying tree structure for SOV languages is essentially identical to that of SVO languages, and the crucial difference between them is the choice of movement strategies used to derive the surface word order. Similar assumptions drive this analysis of VSO word order in SLQZ.

### 3.4 Crosslinguistic Correlations

The preceding analysis of SLQZ VP-raising raises the larger issue of whether VP raising is responsible for VSO word order crosslinguistically.

There is strong evidence that this may be the case, at least for some VSO languages. In the following section, I show that the morphology and word order constraints on a number of unrelated VSO languages can be accounted for by VP raising. Interested readers may refer to the previous analyses of the derivation of VSO word order in the previous chapters.

### 3.4.1 VP-Raising and VSO: Crosslinguistic Evidence

The preceding chapter showed that previous analyses for deriving VSO word order fail to account for the word order possibilities of SLQZ. Now I address the question of whether the VP-raising proposal given for SLQZ can account for VSO word order and verbal morphology in other languages.

There is strong evidence that it can. Many VSO languages unrelated to SLQZ pose similar syntactic and morphological problems for verbal head movement analyses. Just as SLQZ allows verbs and XPs to participate interchangeably in a number of syntactic constructions, VSO languages as genetically distinct as Irish (Carnie 1995) and Chamorro (Chung 1998) likewise allow verbs and phrasal non-verbal predicates to participate in the same constructions:

109. Is [np ambránj [cp aL bhuaifidh an píobaire t<sub>j</sub>]  
       c       song       COMP play.fut the piper

(é) “Yellow Submarine”  
 agr

“Yellow Submarine” is a song which the bagpiper is going to  
 play”  
 (Irish: Carnie 1995, p. 194)

110. Nang, kao ti ginin i gima' yúyu'us hao?  
       Mom Q   not from the house God.Prog you  
       “Mom, weren't you (coming) from the church?”  
       (Chamorro: Chung 1998, p. 55)

In the Irish example, Carnie argues that the predicate “a song which the bagpiper is going to play” occupies a position normally occupied by a verbal head. In the Chamorro example, the PP “from the church” is marked with progressive aspect (realized as reduplication of the primary stressed open syllable) in the same way as a verbal predicate would be.

While Chung independently concludes that both verbal and non-verbal predicates in Chamorro should be treated as XPs, Carnie proposes

that phrasal predicates in Irish be treated as heads.<sup>8</sup> I will discuss Carnie's proposal in the appendix to this chapter.

A number of VSO languages also show verbal morphology patterns which, like those in SLQZ, cannot be accounted for by head movement. A common (though not universal) feature of VSO languages, for instance, is the presence of preverbal tense/aspect markers. As previously argued for SLQZ, this ordering cannot be derived by verbal head-movement if the Mirror Principle and principles of antisymmetry are to be maintained, and if standardly held assumptions about the ordering of functional projections such as TP are to hold. Under standard head-movement accounts of verb-movement, tense markers are incorporated into verbal heads when the verb raises into the head of a higher Tense projection. Head-movement models of verb-movement account for the verbal morphology of languages such as English and French, where tense/aspect morphemes follow the verb. However, if morpheme ordering is necessarily a "mirror image" of syntactic hierarchy (and only left adjunction is possible), then the existence of preverbal tense/aspect markers that form syntactic units with verb stems is problematic: if head-movement is assumed, then either the verbal head right-adjoins to the tense morpheme generated higher in the tree (violating antisymmetry) or the tense morpheme itself is generated lower than the verb, and itself raises and left-adjoins to the verb. This ordering of TP is unattested in the literature.

Now I will address a few specific cases: A number of Eastern Polynesian languages (e.g., Hawaiian (Elbert and Pukui 1979), Easter Island (Chapin 1978)) show an ordering of morphological material on verbs parallel to that of SLQZ. That is, the verbal stems are preceded by tense/aspect and causative markers, and followed by adverbial markers, applicative markers, and agreement:

111. Ua 'a pono 'ia keia pila  
 perf caus-proper-passive this bill  
 "This bill was approved"  
 (Hawaiian: Elbert and Pukui 1979)

It should be noted, however, that the inventory of verbal morphemes available in these languages does not correspond exactly to that of SLQZ. What is crucial for the analysis to follow is the relative order of tense and causative marking on the verb stems: as argued earlier in this chapter, such ordering is impossible to derive under standard head-movement accounts of verb movement, if left adjunction is assumed to be the only option.

---

<sup>8</sup> Chung, however, explicitly argues against the existence of a single underlying structure for all VSO languages.

Chapin (1975) posits the following template for Easter Island inflected verbs:

112. Tense/aspect -Head -Adverb -*ro* Prog. Deictic PVD

where *ro* is an “individual marker” which “expresses the idea that the action referred to is one which was imposed on the subject, not carried out voluntarily”, Prog. appears in progressive constructions, and PVD is one of four “postverbal demonstration” particles. (From the examples in Chapin’s work, it appears that only the tense/aspect marker and head are mandatory in all verbal constructions.) Easter Island, then, also shows a patterning of verbal morphemes similar to that of SLQZ: tense/aspect marking to the left of the verbal stem, and adverbial suffixes/clitics to the right. As previously argued for SLQZ, such ordering cannot be derived under standard head-movement analyses of verb movement, if the standardly accepted ordering of functional projections is to be maintained.

Thus, there is suggestive morphological evidence that other VSO languages may also employ VP-remnant movement as their verb-movement strategy. In the next sections, I will show syntactic evidence supporting this possibility.

### ***Polynesian Subject Clitics***

Further evidence for VP-raising as a possible basis for VSO word order is the distribution of second-position clitics in Polynesian languages. In Samoan and Tongan, both VSO languages, subjects generally follow the verb, which is preceded by a tense/aspect marker:

113. na’e puke ia  
 past sick she  
 “She was sick”  
 (Tongan: Chung 1976, p. 83)

114. ‘olo’o tautala lemu ia ‘oe  
 prog. talk soft that you  
 “You’re speaking softly”  
 (Samoan: Chung 1976, p. 86)

Pronominal subjects, however, may appear as clitics between the tense marker and verb. Cliticized subjects take a distinct morphological form from their non-cliticized counterparts, and form a phonological word with the tense marker:

115. na’e ne puke  
 past she sick  
 “She was sick”  
 (Tongan: Chung 1976, p. 83)

116. 'olo'o 'e tautala lemu  
 prog. you talk soft  
 "You're speaking softly"  
 (Samoan: Chung 1976, p. 86)

Objects and oblique arguments may not appear in this preverbal position:

117. na'e ui ia 'e he tangata  
 past call her erg the man  
 "The man called her"  
 (Tongan: Chung 1976, p. 85)

118. \*na'e ne ui 'e he tangata  
 past her call erg the man  
 "The man called her"  
 (Tongan: Chung 1976, p. 84)

119. sa tausi latou e le teine  
 past care them erg the girl  
 "The girl took care of them"  
 (Samoan: Chung 1976, p. 88)

120. \*sa latou tausi e le teine  
 past they care erg the girl  
 "The girl took care of them"  
 (Samoan: Chung 1976, p.88)

Further constraints on subject cliticization vary between the two languages. In Samoan, non-emphatic pronominal subjects are obligatorily cliticized. Emphatic subjects may not appear as preverbal clitics. Subject cliticization of third-person singular subjects of intransitive verbs is also disallowed:

121. 'olo'o tautala lemu 'oia  
 prog talk soft she  
 "She's speaking softly"  
 (Samoan: Chung 1976, p. 89)

122. \* 'olo'o ia tautala lemu  
 prog she talk soft  
 "She's speaking softly"  
 (Samoan: Chung 1976, p. 89)

In Tongan, on the other hand, cliticization of pronominal subjects is obligatory except for third-person singular pronominal subjects, which may cliticize optionally. (The constraints on third-person singular subjects

are intriguing, but beyond the scope of the present work. I will leave them aside for future investigation.)

While Samoan disallows cliticization of emphatic subject pronouns, Tongan does allow pronominal subjects with emphatic or contrastive readings. In these cases, however, pronoun doubling occurs: a second pronoun (in full, non-clitic form) appears postverbally:

123. na'a ma 'ave 'e kimaua ho'o telephone  
 past we=du take erg we=du your telephone  
 "WE took away your telephone"  
 (Tongan: Chung 1976, p. 83)

These data suggest that VP-raising can be posited for Tongan and Samoan as well. While cliticization of this type is generally viewed as raising of the cliticized pronoun, I propose that the cliticized, non-case-marked subject clitics are in fact in situ pronominal subjects inside VPs raised to TP. The following tree reflects the proposed structure for the Tongan example in (115), *na'e ne puke*, "She was sick" (functional projections for aspect, mood, etc. omitted for clarity). Here I assume that in Tongan, as in SLQZ, fronted VPs are dominated by  $VP_{asp}$ , which contains the preverbal tense/aspect marker:

124.

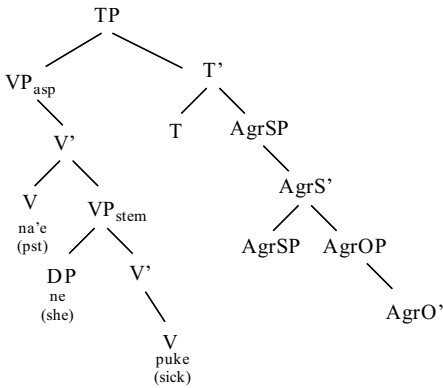

Postverbal pronominal subjects are those raised to Spec, AgrSP. The VP complex containing the Tense marker in the higher shell and the verbal root in the lower VP shell raises to TP, as in SLQZ:

125.

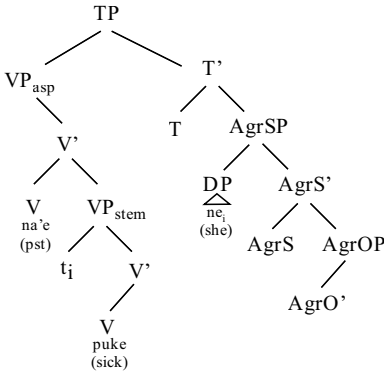

This structure may account for the different morphological forms of cliticized and non-cliticized pronouns: one possibility is that the case markers on full, postverbal pronominal subjects are determiners whose features need to be checked by movement to Agr, thus forcing their extraction from VP.

Additional support for VP-raising comes from the distribution of definite and indefinite objects in Tongan. Definite objects in Tongan follow lexical subjects:

126. Na'e kai 'e Sione e maá  
 past eat def John def bread  
 "John ate the bread"  
 (Shumway 1988, p. 188)

Tongan has a number of verbal constructions, however, in which the verb and indefinite object together are treated as a single lexical unit. One such expression is *kai maá* "eat bread". When an indefinite object is used in such a construction, it precedes, rather than follows, a lexical subject:

127. Na'e kai maá 'e Sione  
 past eat bread def John  
 "John ate bread"  
 (Shumway 1988, p. 188)

In this example, the indefinite object appears to have undergone movement along with the verb to pre-subject position. Assuming Kayne's requirement that heads only adjoin to the left of other heads, the object could not have joined to the verb via incorporation.

The contrast in word order between (126) and (127) can be easily accounted for under a VP-raising analysis. When objects are definite,

they raise out of VP to AgrO. The VP (containing the tense morpheme and traces of the raised object and subject) raises to spec, TP:

128.

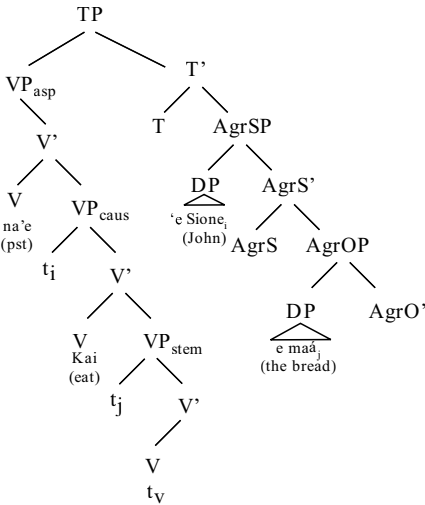

When objects are indefinite, they remain inside VP. The subject raises out to spec, AgrSP, and the VP raises to spec, TP:

129.

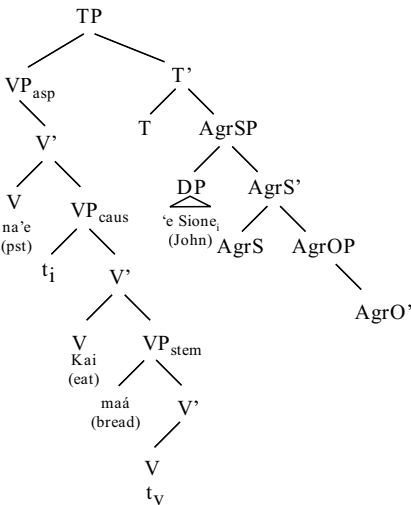

The placement of indefinite objects inside VP is also consistent with Diesing's (1992) proposal that indefinite arguments take scope inside VP, while definite arguments raise out of VP to receive definite interpretations.



Furthermore, head-movement accounts of the cliticization process fail to produce all and only the allowable constructions. I will now consider the possible verbal head-raising scenarios that could potentially generate the allowable word orders.

In all of these scenarios, I assume that the tense marker is generated in the head of T. Subjects are generated VP-internally. Thus, a possible underlying structure for (116) would be as follows:

130.

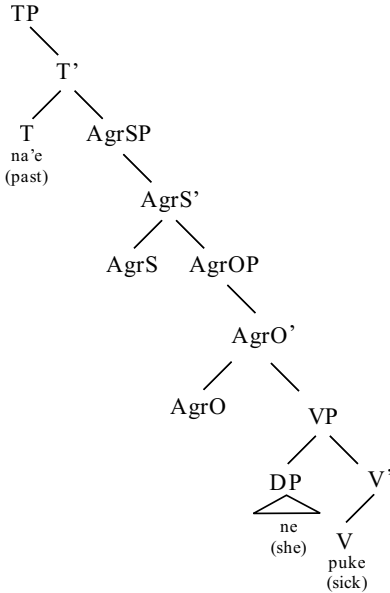

In order for the tense marker to precede the verb at spell-out, it must be assumed that the verb does not raise to and incorporate into T until LF. Thus, Tense features in Tongan are weak: they do not require the verb that receives these features to move in the overt syntax.

If this is the case, then the cliticized subject constructions can be easily derived: the verb remains in situ at spell-out, and the subject pronoun raises to spec, AgrSP or remains in situ itself in spec, VP.

This raises the question, however, of how to derive sentences with lexical subjects, which appear postverbally:

131. Na'e kai 'e Sione e maá  
 past eat def John def bread  
 "John ate the bread"  
 (Shumway 1988, p. 188)

Here, it must be assumed that the verb raises to a position above the subject, but below the tense marker in TP. One possibility is that it undergoes "partial movement" to the head of AgrSP, leaving the subject stranded in spec VP. Such movement, however, seems unmotivated: why

would the verb be required to raise in these cases? Since Tongan verbs appear without overt person/number inflection, it appears that these features are weak, and thus do not need to be checked by overt movement. Also, if it is possible for such normally weak features to be satisfied early by overt movement (in clear violation of Last Resort) what blocks the verb from undergoing further movement to TP at spell-out?

The above data show that for Tongan and Samoan, VP-remnant movement accounts for possible word order alternations, while head-movement of the verb fails to do so.

### ***Berber Second-Position Object Clitics***

Further evidence for the phrasal status of verbs in VSO languages comes from the distribution of second-position object clitics in Berber, an Afroasiatic language. As with the SLQZ second-position adverbial clitics discussed in Section 1.1, the Berber clitics may cliticize both to verbs and clearly phrasal constituents. Lee and Ouhalla (1998) note that a unified account for the second-position clitic construction is only possible if verbs are assumed to undergo the same type of movement as the other XPs. Object and directionality clitics in Berber appear in the second position in a sentence, after *wh*-words, focused XPs, clausal negation, or clause-initial verbs:<sup>9</sup>

132. (\*CL) V (CL)  
 wh-XP (CL) V (\*CL)  
 foc-XP (CL) V (\*CL)  
 neg (CL) V (\*CL)
133. Min as y-usha ufrux?  
 what to-her 3MS-gave boy  
 “What did the boy give her?”
134. Tafirast ay as y-usha ufrux  
 pear FM to-her 3MS-gave boy  
 “It’s the pear that the boy gave her”
135. Ur as y-usha ufrux tafirast  
 neg to-her 3MS-gave boy pear  
 “The boy didn’t give her the pear”
136. Y-ush as ufrux tafirast  
 3MS-gave to-her boy pear  
 “The boy gave her the pear”

<sup>9</sup> These clitics, however, may not directly follow left-dislocated subjects, which are interpreted as topics.

If it is indeed the case that these examples all exemplify the same construction, the fact that verbs may precede object/directionality clitics appears problematic. Apart from the verbal cases such as (136), the other constituents that trigger clitic-second form a natural class: *wh*-words, focused constituents, and clausal negation can be analyzed as XPs containing operators. These constituents are assumed to occupy high (pre-AgrSP/TP) positions in the tree.

If pre-clitic verbs in constructions such as (136) are assumed to be heads, then it must also be assumed that clitic-second in these cases is a derived differently than in the other cases. Ideally, however, any account of pre-clitic verbs must be consistent with other contexts in which second-position clitics are allowed.

Thus, the only solution that allows all clitic-second constructions in Berber to be treated as uniform derivations is to assume that clause-initial verbs in clitic constructions such as (136) are remnant VPs in the spec of CP/FocP. (In the presence of other constituents in CP/FocP, VP remains in TP.) This allows the clitic to be analysed as occupying the same position in all contexts, and allows verb-initial clitic constructions to be structurally unified with XP-initial clitic constructions.

### **3.5 Conclusion**

In this chapter, I showed both morphological and syntactic evidence that verbs in SLQZ should be construed as remnant VPs, rather than verbal heads. This evidence included the ordering of verbal morphemes, and the phrase-like behavior of verbs in certain syntactic constructions. I showed that while there is no principled way to derive the morphological ordering of SLQZ verbs via head movement, a remnant VP-raising strategy can account for both the morpheme ordering and syntactic distribution of SLQZ verbs in a principled way.

I also showed crosslinguistic evidence that VP-remnant raising accounts for VSO word order in a number of unrelated languages, as well as some of the typological features often associated with verb-initial languages (such as preverbal tense/aspect markers and predicates with phrase-like syntax).

### 3.6 Appendix to Chapter 3: Considering Head Movement of XPs

#### 3.6.1 The Phrasal Head-Movement Proposal: Carnie 1995

An alternate approach to the problem of syntactically interchangeable verbs and phrasal categories is proposed by Carnie (1995). He notes cases in Modern Irish (also a VSO language) in which nominal and adjectival predicates, which can contain entire phrasal categories and should thus be assumed to be XPs, undergo what appears to be head-movement. He proposes (following Chomsky 1995) that the X/XP distinction is an archaic artifact of X' theory and that it is possible, in effect, for phrasal categories to be treated as heads and thus undergo head movement. (Stowell 1981 likewise suggests the possibility of phrasal constituents incorporating into verbal heads.) Carnie also shows evidence from other languages suggesting that large constituents crosslinguistically may also undergo similar processes. He gives several examples from a range of languages (including Persian, Yoruba, and Yiddish) in which large, apparently phrasal constituents undergo movement considered to be limited to heads or take affixes normally subcategorized by heads.

One piece of evidence that Carnie presents for analyzing complex predicates as heads comes from wh-extraction constraints in Irish. No material may be extracted from inside a non-referential predicate nominal (such as (137)) by wh-movement (138):

137. Is [np ambrán<sub>i</sub> [cp aL bhuaifidh an píobaire t<sub>i</sub>]  
 c song COMP play.fut the piper  
 “Yellow Submarine” is a song which the bagpiper

(é) “Yellow Submarine”  
 agr  
 is going to play”  
 (Carnie 1995, p. 194)

138. \*Cén píobaire<sub>j</sub> arb [np ambrán<sub>i</sub> [cp aL bhuaifeadh sé<sub>j</sub> t<sub>i</sub>]  
 which piper rel song COMP play.cond he  
 “Which bagpiper is “Yellow Submarine” a song which

(é) “Yellow Submarine”  
 agr  
 he/t<sub>i</sub> is going to play?”  
 (Carnie 1995, p. 194)

Carnie argues that the nominal status of the predicate should not be considered the cause of the ban on extraction, since *wh*-extraction may occur out of other nominal phrases in Irish:

139. Tá máthair an fhir san otharlann  
be.pres mother the man.gen in.the hospital  
“The man's mother is in the hospital”  
(Carnie 1995, p. 193)
140. Cé aN bhuil a<sub>i</sub> máthair san otharlann  
who COMP be.pres. his mother in.the hospital  
“Who is (his) mother in the hospital?”  
(Carnie 1995, p. 193)

Thus, Carnie argues, the only explanation for the ban on extraction out of the complex nominal predicate in (138) is that has been reanalyzed as a word (head), and thus can no longer be broken up by extraction.

### 3.6.2 Against Complex Head-Movement

Carnie's data and analysis are provocative. Like SLQZ, Irish has a number of constructions in which non-head constituents and heads can undergo identical syntactic processes. Carnie proposes that rather than positing putative “heads” as XPs, the constituents that appear to be XPs should be treated as heads. This raises an obvious question: can this strategy work for SLQZ as well?

A strictly theory-internal reason against complex head-movement is that it raises problems for Kayne's antisymmetry constraints. If a large non-head dominating a number of terminals itself (such as a complex nominal predicate) raised into a head, a structure such as the following would result:

141.

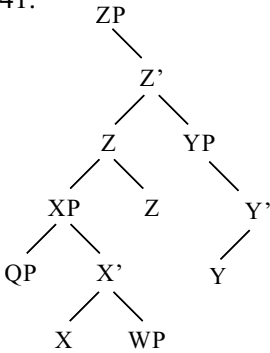

In this structure, XP would be the complex predicate that “head-moves” into the head of Z (the exact nature of these categories being irrelevant here). This results in a non-head (XP) being adjoined to a head (Z), which, as seen earlier, forms an illicit structure. The complement of XP, WP, linearly precedes YP, but cannot c-command it (by Kayne’s definition) because it is dominated by XP and YP is not. The structure is thus not fully antisymmetric, and thus illicit.

Furthermore, there may be independent reasons why the Irish contrasts in (1-4) occur. Consider again the data in (1-4): these examples intend to show that while Irish allows wh-extraction from complex nominals, it does not allow wh-extraction from nominal predicates. Carnie proposes that the island status of complex predicate nominals stems from their status as syntactic heads.

A possible explanation for this constraint could be the position in which nominal predicates appear. In SLQZ and a number of other languages (such as Hausa), nominal and adjectival predicates occupy the same slot as focused constituents (in SLQZ, the immediately preverbal position, as seen in (142)). This position, when filled (143), blocks wh-movement:

142. Mee’s n-àa Gye’eihlly  
 teacher neut-be Mike  
 “Mike is a teacher”

143. \*Tu mee’s n-àa?  
 who teacher neut-be  
 “Who is a teacher?”

In order for wh-movement past a predicate nominal to occur in SLQZ, the predicate nominal must appear in postverbal position rather than in its normal preverbal position:

144. Tu n-àa mee's?  
 who neut-be teacher  
 "Who is a teacher?"

This suggests that preverbal nominal predicates in SLQZ either occupy the same position as *wh*-words or a position that blocks *wh*-movement for independent reasons. (A more detailed account of the interaction between *wh*-movement and focus is presented in Chapters 4 and 5.)

If predicate nominals occupy a similar position in Irish, then the ban on extraction out of complex predicates could be the result of the actual position of the predicate itself, not its lack of internal structure.

Another possibility is that different types of nominal expressions in Irish simply have different constraints on extraction. In English, for instance, *wh*-extraction out of relative clauses is clearly disallowed (145), while *wh*-extraction out of possessive constructions is allowed in certain registers, as noted by Kayne 1993 (146):

145. \*Who do you think the man that hit t sued?

146. Who do you think t's mother is in the hospital?

It is plausible that similar constraints may hold in Irish.

There are also language-specific reasons against extending Carnie's analysis to SLQZ, and thus treating all SLQZ predicates as heads. While both Irish and SLQZ have syntactic constructions in which phrases and heads apparently appear interchangeably, these constructions differ across the two languages. In Irish, the problem cases appear to be limited to those in which phrasal categories (complex nominal predicates) appear in positions normally associated with heads: specifically, these predicates may appear in positions normally reserved for verbal heads. In SLQZ, problematic cases include those in which apparent heads (verbs) appear in positions normally associated with XPs (such as the constituent negation construction and adverbial clitic constructions described in Section 3.2.1). If we assume that verbs in SLQZ are indeed heads, and that heads thus may undergo the same type of constituent negation as nominals and prepositional phrases, then we would have to assume that nominal arguments and PPs are likewise treated as heads in the syntax.

### 3.6.3 XP-Raising Analyses for Irish

I have made a number of arguments why complex predicates should not be treated as heads in SLQZ. But is it still a workable option for languages such as Irish?

Other recent work on Irish supports the possibility of the VP-raising analysis argued for here. Other researchers have independently proposed

XP-raising analyses of Irish (Duffield 1993, 1995; Noonan 1999). Duffield notes that the possibility of apparently “right adjoined” adverbial phrases and light pronouns is highly inconsistent with the otherwise completely head-initial syntax of Irish, and proposes that adverbial phrases and pronouns end up at the right edge of sentences because they are generated high (adjoined to TP) and the remainder of the sentence (the TP containing the verb, subject, and object) raises past it. Thus, sentence-final adverbs in Irish sentences such as that in (147) result from the movement process in (148):

147. Chonaic Máire an fear sa tsráid i nDoire inné  
 saw Mary the man in-the street in Derry yesterday  
 “Mary saw the man in the street in Derry yesterday”  
 (Duffield 1994: p. 221)

148.

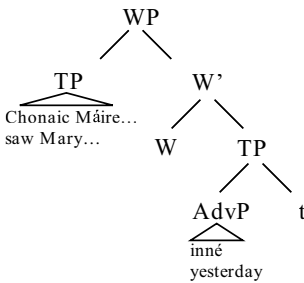

Noonan’s (1999) analysis of the Irish particles *aL* and *aN* also points to a VP-raising analysis. *AL*, which appears between fronted *wh*-words and verbs when subjects or objects are *wh*-moved, and *aN*, which appears between verbs and fronted PPs or adverb phrases, have been previously analysed as “agreeing complementizers” (McCloskey 1979, cited in Noonan 1999). Their presence was argued to be direct evidence for successive cyclic *wh*-movement:

149. Cén páistí a chreideann Seán a d'imheodh \_\_\_ anseo?  
 which children *aL* believes Sean *aL* play-COND here  
 “Which children does Sean believe would play here?”
150. Céard leis a ndearna tú é?  
 what with-3s *aN* did you it  
 “With what did you do it?”



The particle *aL* also appears before fronted objects in infinitival clauses:

151. Ba mhaith liom [Seán an caora a mheá ar an bhfeirm]  
 I would like Sean the sheep aL weigh on the farm  
 “I would like Sean to weigh the sheep on the farm”

In this context, *aL* has been analysed as a reflex of specifier-head agreement between the object DP and verb (Duffield 1995, Noonan 1994, cited in Noonan 1999).

When a PP or adverbial phrase raises through more than one clause, however, *aN* appears only in the lowest clause. The particle *aL* appears in front of all higher clauses the wh-adjunct raises through:

152. Cé shíleann Máire a chreideann Seán ar labhair Nic leis  
 who (aL) think M. aL believes Sean aN spoke Nic with-agr  
 “Who does Mary think that John believes that Nic spoke with?”

Noonan points out that the appearance of both *aL* and *aN* in these cases cannot be accounted for by the argument that *aL* represents agreement with wh-moved arguments, while *aN* agrees with wh-moved adjuncts: if this were the case, then *aN* should appear in every clause the adjunct wh-expression raises through.

She argues instead that *aL* in multiclausal wh-questions is not a reflex of successive-cyclic wh-movement, but of VP/CP fronting. When a wh word raises out of an embedded CP, the CP itself raises to the front of the next CP up. This movement is exemplified in the derivation for the following example:

153. Céard a chreideann Seán [pro a dhéanfá \_\_\_]?  
 what aL believes Sean pro aL would-say-2s  
 “What does Sean believe you would say?”

The base-generated structure appears as follows:

154. [chreideann Seán [pro dhéanfá céard]]  
 believes Sean pro would-say what

Wh-movement of the object triggers the appearance of *aL* in the lower clause:

155. [chreideann Seán [céard pro a dhéanfá t]]  
 believes Sean what pro aL would-say

The embedded CP itself fronts to the left of the matrix clause, thus triggering the appearance of *aL* before the matrix verb:

156. [céard pro a dhéanfá t] [ a chreideann Seán t<sub>CP</sub>]  
 what pro aL would-say aL believes Sean

The matrix remnant VP then fronts itself:

157. [ a chreideann Seán t<sub>CP</sub>] [céard pro a dhéanfá t]  
 aL believes Sean what pro aL would-say

Finally, the wh-word raises to the leftmost spec, CP:

158. Céard [ a chreideann Seán t<sub>CP</sub>] [t<sub>wh</sub> pro a dhéanfá t<sub>wh</sub>]  
 what aL believes Sean pro aL would-say

Thus, the functions of *aL* in wh-constructions and in object-fronting constructions can be unified: in both cases, *aL* represents agreement triggered by fronting of a complement, either clausal or nominal. This also accounts for the distribution of *aL* and *aN* in embedded adjunct wh-questions: since *aL* reflects only fronting of arguments and clausal complements, wh- extraction of non-arguments does not trigger the appearance of *aL* in the clause from which extraction takes place.

If Duffield's and Noonan's accounts are correct, then the ability of verbal and phrasal predicates to appear interchangeably in certain Irish constructions is amenable to the same solution as that proposed for SLQZ: the verbal form that undergoes movement is a VP remnant rather than a verbal head, and verbal movement is XP movement.

## 4 Further Consequences of VP-Remnant Movement: Some Common Negation Structures in SLQZ

### 4.1 Overview of Three Basic SLQZ Negation Constructions

SLQZ has a rich inventory of negative constructions. In the previous chapter, some of these were used as evidence for remnant movement of VP, rather than head-movement of V, in SLQZ grammar. This chapter will provide explicit syntactic accounts for three of the most common negation structures in SLQZ: clausal negation with the negative marker *cě'ity* (1), focus/constituent negation with the negative marker *a'ti* (2), and indefinite/existential negation with the negative marker *tè'bag* (3):

#### Clausal Negation:

1. *Cě'ity* ny-àa'z-dya' Gye'eihlly Li'eb  
neg subj-beat-dya' Mike Felipe  
“Mike didn't hit Felipe”

#### Constituent Negation:

2. *A'ti* Sann Luu'c-dya' gw-eh Pa'amm  
neg San Lucas-dya' perf-go Pam  
Pam didn't go to SAN LUCAS (but rather somewhere else)”

#### Indefinite/Existential Negation:

3. *Tè'bag* calii ch-o'o-dy-ënn izhih  
no where irr-go-dya'-lp tomorrow  
“We won't go anywhere tomorrow”

This chapter will show how VP-raising provides semantic, as well as syntactic, motivation for some of the structures discussed. Examination of these negative constructions will also afford an opportunity to refine and elaborate upon the tentative hierarchy of functional projections posited in the last chapter, and will provide evidence for some antisymmetry-driven constraints on movement.

At first glance, these three negative constructions look quite similar, as can be seen in the preceding examples. In all cases, negation is clause-initial, and negated constituents appear between two markers indicating negation. On closer examination, however, these patterns prove to differ syntactically in interesting ways. These differences reveal much about the inventory of functional projections and their order in SLQZ.

I will begin my discussion of negation with a brief account of the syntactic and semantic features of the clitic *-dya'*, which appears after negated constituents in all three of the negation constructions under discussion. I will then examine and propose analyses for clausal negation, constituent negation, and finally, existential negation.

## 4.2 What Does *-dya'* Do?

In all three of the negative constructions shown above, negated constituents are followed by the clitic *-dya'* (or its variant, *-di'*). Because its semantic features are complex and not limited to negation, I will leave it unglossed.

*Dya'*, which appears (nearly) obligatorily in all three negative constructions, also appears in other, non-negative constructions. It may appear as a clitic on focus-fronted constituents to mark them as occupying a low point on some contextually determined scale:

4. X:-bu'uhdy-dya' Li'eb w-laàa'n Gye'eihlly  
 poss-chicken-dya' Felipe perf-steal Mike  
 "All Mike stole was Felipe's chicken  
 (and not anything better)"
5. Nnyi'ihs-dya' b-dèèi'dy Gye'eihlly gw-èè'eh Li'eb  
 water-dya' perf-give Mike perf-drink Felipe  
 "All Mike gave Felipe to drink was water (even though there was  
 lots of other stuff)"

It also appears on clause-initial constituents to mark degree or extent (P. Munro, p.c.):

6. Terseer-di' gu-allda-a'  
 third-dya' perf-arr-1s  
 "I went as far as third grade" (ML 1997)
7. Cali-dya' r-uhny Li'eb zèèi'ny?  
 where-dya hab-do Felipe work  
 "How far away does Felipe work?"

It may also appear on non-negated verbs. In these contexts, it appears to highlight points in time to indicate suddenness of an event:

8. Ca-yii'ah-dya' Gye'eihlly nnaħ chih b-iahb  
 prog-drink-dya' Mike chocolate when perf-fall  
 "Mike was drinking chocolate when

ba'gêizh loh-ih  
 fly in-3s.dist  
 a fly fell into it"

9. Cay-auw-dya' Gye'eihlly gueht  
 perf-eat-dya' Mike tortilla  
 "Mike was eating (tortillas)

chih b-cuhni'ih Li'eb zh:àa'n-ih  
 when perf-kick Felipe rear-3s.dist  
 when Felipe kicked his butt"

Thus, while *-dya'* appears to contribute little meaning of its own when under the scope of negation, it does make a semantic contribution when it appears outside the scope of negation.

*-Dya'* appears to be semantically and syntactically reminiscent of English *any*: like *-dya'*, *any* may appear both under the scope of negation (where it has traditionally been called "negative polarity *any*") and in non-negative contexts (the so-called "free-choice" use of *any*). The differing uses and interpretations of *any* in these contexts show some parallels to those of negative and non-negative *-dya'* in SLQZ.

Under the scope of negation, *any* contributes no truth-functional value to expressions in which it appears:

10. Mike didn't eat (any) grasshoppers

It can, however, add a slightly more emphatic feel to the sentence: in the preceding example, it could potentially express the idea that it was not only the case that Mike failed to eat grasshoppers, he was unwilling to eat them or consider eating them.

SLQZ *-dya'* makes no such contributions to the semantics of negative sentences. In SLQZ, there are contexts (which will be accounted for in the sections to follow) in which *-dya'* may be omitted in negative constructions. Such constructions suggest that *-dya'* under negation, like negative-polarity *any*, contributes little semantically to the structures in which it appears. Compare (11), without *-dya'*, to (12), a standard clausal negation structure with *-dya'*:

11. Gye'eihlly cē'ity n-àa me's  
 Mike neg neut-be teacher  
 "MIKE is not a teacher"

12. Cë'ity n-àa -dya' Gye'eihlly me's  
neg neut-be-dya' Mike teacher  
"Mike is not a teacher"

The absence of *dya'* in (11) is syntactically motivated by movement constraints triggered by focus-fronting of the subject *Gye'eihlly*, "Mike"; this and other constraints on the distribution of *-dya'* will be discussed in detail in Section 4.3.2.

Outside the scope of negation, however, *any* receives possible readings similar to some of those available to non-negative-*dya'*: As argued by Kadmon and Landman (1990), *any* serves to denote an (extreme) point on a contextually fixed scale:

13. Any match that you strike will light  
14. Anyone can finish this puzzle in five minutes

In (13), use of *any match* suggests that even defective or unusual matches might work in the context introduced by the sentence; in (14), use of *anyone* implies that even those normally assumed to be unable to finish puzzles (such as unusually slow people or small children) would be able to complete the puzzle under discussion. In short, Kadmon and Landman argue, *any*, in both negative-polarity and non-negative contexts, serves to expand the range of contextually acceptable objects that can be introduced into the discourse. This would account for the interpretation of *any* in both non-negative contexts such as (13-14) and the emphatic negative flavor of *any* under negation in examples such as (10). The interpretation of non-negative *any* in English appears quite similar to the contribution made by *-dya'* in non-negative contexts such as (4-5).

While negative-polarity *any* can add emphatic readings to contexts in which it appears, *-dya'* under the scope of negation, as previously noted, does not. The lack of any semantic contribution by *-dya'* to negative expressions, along with fact that *-dya'* is obligatory in most negative contexts, suggests that it has been reanalyzed from an optional negative polarity item expressing emphatic negation (like negative polarity *any*) to an obligatory function word necessary for the syntactic realization of negative structures. I will thus argue that while it seems probable that *-dya'* in SLQZ may have been derived from an indefinite quantifier much like English *any*, its quantificational force has been bleached in negative contexts. In the following sections, I will discuss how this is realized in the syntax.

### 4.3 Clausal Negation

Clausal negation in SLQZ is expressed with two morphemes: *cě'ity*, which precedes the verb, and *-dya'*, which immediately follows the verb and precedes the subject:

15. Cě'ity ny-àa'z-dya' Gye'eihlly Li'eb  
 neg subj-beat-dya' Mike Felipe  
 "Mike didn't hit Felipe"

Two-part negation structures are common crosslinguistically, and have been generally assumed to result from spec-head agreement of negative morphemes in NegP. Thus, there are two possible structures for SLQZ clausal negation: either the preverbal negative morpheme *cě'ity* is the head of NegP and the postverbal clitic *-dya'* is the specifier (as has been suggested for the preverbal negative morpheme *ne* and postverbal negative morpheme *pas* in French clausal negation (Moritz and Valois 1992), or preverbal *cě'ity* is the specifier of NegP and postverbal *-dya'* the head (as suggested for the preverbal and postverbal negative particles in the Grassfields Bantu language Nweh by Nkemnji 1995).

#### 4.3.1 Reasons Why *cě'ity* Is a Specifier, *-dya'* a Head: Evidence from *-zhya'* Cliticization

There is reason to believe that in SLQZ, the preverbal negative marker *cě'ity* is in the specifier of NegP, while *-dya'* is the head, parallel to the account proposed for Nweh by Nkemnji 1995.

This evidence comes from the distribution of the modal clitic *-zhya'* in clausal negation structures. Recall from the previous chapter that *-zhya'* cliticization was used as a diagnostic for XP status. The fact that *-zhya'* may cliticize to verbs, as well as to DPs and PPs, was argued to be a diagnostic for the XP status of SLQZ verbs:

16. N-u'-zhya'-rěng Lohs Aa'nngl  
 neut-exist-might-3p.prox Los Angeles  
 "They might be in Los Angeles"
17. Lohs Aa'nngl-zhya' n-u'-rěng  
 Los Angeles-might neut-exist-3p.prox  
 "Los Angeles might be where they are (not somewhere else)"
18. Laa'iny yu'uh-zhya' n-u'uh li'ebr  
 in house-might neut-exist book  
 "The book might be in the house"

Thus, I will continue to assume that the ability of a constituent to participate in *-zhya'*-cliticization indicates its XP status.

In clausal negation structures, *-zhya'* can cliticize to *cë'ity*. This suggests that *cë'ity* is an XP as well. Compare a simple example of clausal negation (19), a non-negated sentence where *-zhya'* cliticizes onto the verb (20), and a clausal negation structure with *-zhya'* (21):

19. Cë'ity n-gya'a-dya' Gye'eihlly  
neg subj-dance-dya' Mike  
"Mike didn't dance"

20. B-gya'a'-zhya' Gye'eihlly  
perf-dance-might Mike  
"Mike might have danced"<sup>1</sup>

21. Cë'ity-zhya' n-gya'a-dya' Gye'eihlly  
neg-might subj-dance-dya' Mike  
"Mike might not have danced"

The modal clitic *-zhya'* cannot cliticize to *-dya'* in clausal negation constructions. This suggests that *-dya'* is not an XP:

22. \*Cë'ity n-gya'a-dya'-zhya' Gye'eihlly  
neg subj-dance-dya'-might Mike  
"Mike might not have danced"

By extension, this suggests that the *cë'ity-verb-dya'* complex does not form a movable XP constituent, even if *cë'ity* and *-dya'* are required to appear in spec-head agreement with each other at some point in the derivation. Independent evidence for this will be shown in the following sections.

Under the assumption that verbs in SLQZ are actually VP remnants rather than heads, and negation is realized by movement into NegP, negated verbs must raise into NegP via XP-movement. Thus, they raise into the specifier of NegP. Under the assumption that two-part negation results from spec-head agreement, this would place *-dya'* in the head of NegP.

I will assume that *cë'ity* is base-generated in a quantifier phrase that takes scope over VP. The QP containing the VP raises into Spec, NegP thus falling into specifier-head agreement with *-dya'*, as seen in (23)<sup>2</sup>:

<sup>1</sup> As described in Chapter 1, the Subjunctive aspect rarely appears in non-negated matrix clauses, but is used in place of Perfective aspect in negated sentences.

<sup>2</sup> This structure raises the issue of how *-zhya'* cliticization with *cë'ity* can take place, since here *cë'ity* takes a verbal complement. I will assume that it is possible for the VP complement to raise independently of *cë'ity* in some contexts, leaving the QP and the trace of VP to raise and cliticize to *-zhya'*.



23.

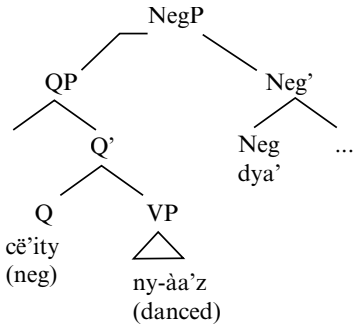

I will thus assume this to be the basic structure for clausal negation. I will discuss in detail the exact position of NegP in relation to other functional projections in the remainder of this chapter.

### 4.3.2 Doubly-Filled Comp Effects: More Evidence for the Structure of Clausal Negation

There is evidence that the *cë'ity*-verb complex undergoes additional movement after raising into spec, NegP. This movement would be consistent with the fact that *cë'ity*, the verb, and *-dya'* together are not treated as a single constituent, as exemplified by the inability of the modal clitic *-zhya'* to follow *-dya'*.

This evidence for movement comes from the fact that *-dya'* is usually omitted in the presence of constituents to the left of *cë'ity*: Such contexts include wh-questions, relative clauses, and negated sentences with focus-fronted arguments:

24. Tu cë'ity r-yu'làa'z-u'  
 who neg hab-like-2s.inf  
 "Who don't you like?"

25. Me's [nih cë'ity y-zhyàag Beed yzh:ii] n-u'uh rèe'  
 teacher [that neg irr-meet Pedro tomorrow] neut-exist here  
 "The teacher that Pedro won't meet tomorrow is here"

26. Gye'eihlly cë'ity n-àa me's  
 Mike neg neut-be teacher  
 "MIKE is not a teacher"

Another context in which *-dya'* is omitted is in the presence of the sentence-final yes/no question marker *èee*. I will argue later in this section that this case can be accounted for identically with those above:

27. Cē'ity r-yu'làà'z Gye'eihlly bx:àady èeè?  
 neg hab-like Mike grasshopper Q  
 "Doesn't Mike like grasshoppers?"

Thus, the presence of overt material above NegP blocks the presence of *-dya'*.

This suggests that an empty projection above NegP is needed if both *cē'ity* and *-dya'* are to appear. This requirement can be accounted for by Koopman's (1996) Generalized Doubly-Filled Comp Filter (GDCF), which rules that no projection may have both its head and specifier filled simultaneously. Apparent cases of specifier-head agreement result from string-vacuous movement of specifiers into higher, empty projections.

Thus, the *cēi'ty*+verb complex actually raises to a higher position after passing through spec, NegP:

28.

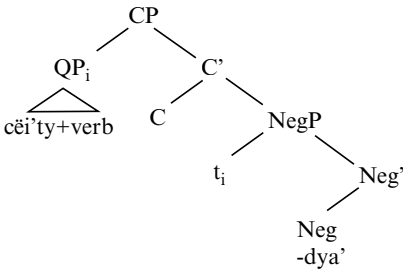

This movement, however, is blocked when the head or the specifier of the CP projection directly above NegP is overtly filled (by either a *wh*-word or a relative marker).<sup>3</sup>

29.

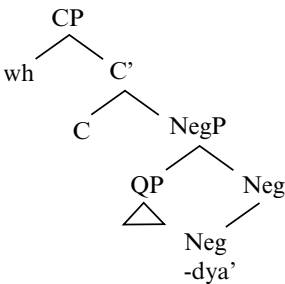

<sup>3</sup> I assume, following Rizzi 1997, that CP actually consists of multiple functional projections, some of which may not be active or available in certain constructions. Evidence for multiple CP projections is given later in this chapter and in chapter 5.

In these contexts, then, the QP containing *cě'ity* has no place to raise to after passing through the specifier of NegP. The structure is thus ill-formed, since it violates the GDCF. For the *cě'ity*-verb complex to stay in NegP, then, material in the head of NegP (*-dya'*) must be suppressed. If *-dya'* is not present, no linear or structural relation need be established between the complements of *cě'ity*: and *-dya'* in the head of NegP, and the structure is thus licit. (Covert material, such as negative features that need to be licensed by movement through the specifier of NegP, however, may still be present.)

The absence of *-dya'* in negated yes/no questions can be explained in similar terms, despite the fact that the question marker surfaces clause-finally: the yes/no question marker *èee*, like wh-words and relative markers, is generated above NegP in C, and the remainder of the sentence raises past *èee* to the specifier of CP (and then, assuming the Generalized Doubly-Filled Comp Filter, on to some higher projection):

30. *Cě'ity r-yu'làà'a'z Gye'eihlly bx:àady èee?*  
 neg hab-like Mike grasshopper Q  
 "Doesn't Mike like grasshoppers?"

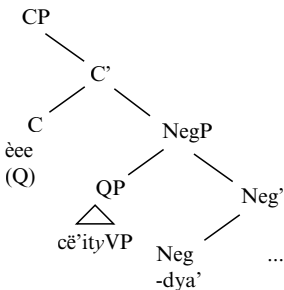

Because the question marker *èee* occupies C, and the remainder of the sentence raises to spec, CP, the raising of QP into CP is blocked. Since QP must remain in NegP, the Generalized Doubly-Filled Comp Filter thus forces the suppression of *-dya'*, as in the wh-question and relative clause cases.

If this analysis of *-dya'* dropping is correct, it further supports the idea that negated verbs are VPs, rather than heads: if Koopman is correct and either specifiers or heads of projections may appear, and if *-dya'* is indeed a head, as previously argued, the fact that verbs remain overtly realized even when *-dya'* is suppressed suggests that verbs cannot be heads that incorporate into *-dya'*.

Furthermore, this supports the idea that *cě'ity* is the specifier, rather than head, of NegP: if VPs are indeed specifiers, and are always overtly realized in clausal negation, this suggests that the negative marker that appears with them also surfaces in Spec, NegP. If *-dya'* were the specifier of NegP, the requirement that *-dya'* be omitted in certain contexts should also apply to verbs, under the assumption that the GDCF is responsible for the

absence of *-dya'*. The fact that it does not suggests that *-dya'* and the QP containing VP appear in different positions. Since it is now clear the VP appears in specifier positions, *-dya'* must appear in the head of NegP.

### **Theoretical Consequences of the Generalized Doubly-Filled Comp Filter**

This analysis explicitly suggests that structural well-formedness be a condition fulfilled at spell-out in SLQZ: movement may occur for strictly structural, rather than feature-checking reasons (as suggested by the additional movement of material from spec, NegP to spec, CP), and deletion of material at PF may likewise be motivated for structural reasons. This is consistent with both Kayne's and Koopman's formulations of antisymmetry requirements.

Koopman's Generalized Doubly-Filled Comp Filter has further consequences for grammatical relations in SLQZ. The GDCF is motivated by Koopman's desire to recognize segments (defined here as branches dominated by  $X'$ ), as well as categories (that is, XPs), as potentially c-commanding entities: she argues that there are cases in which X's should be recognizable for linear and hierarchical mapping (such as incorporation of one head into another, under the traditional assumption that this involves adjunction of a head to an  $X'$ ). Below, I repeat Kayne's definition of c-command (Kayne 1994:16):

31. X c-commands Y iff *X and Y are categories* and X excludes Y and every category that dominates X dominates Y

Under Kayne's restrictions against entering segments into the computation of linear order of constituents, a standard head-incorporation structure such as (32), below, is illicit:

32.

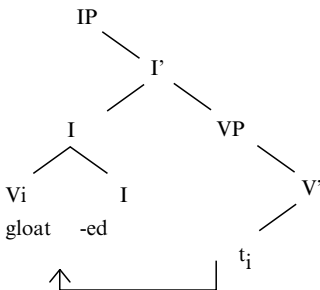

In this structure, the verb “gloat” has undergone head-movement and adjoined to I, which is headed by the tense marker “-ed”. This structure is ruled out under Kayne's account because the linear order between the raised verb “gloat” and the inflectional morpheme “-ed” cannot be defined under the preceding definition of c-command. Since neither the node dominating “gloat” nor that dominating “-ed” are categories (they are both

I's, thus segments of IP), neither can c-command the other, and thus, neither can be assigned linear precedence over the other.

Structures such as (32), however, are standardly assumed to account for head-incorporation structures such as inflected verbs and compound word formation (Baker 1988, Kural 1996, among others). If such structures are indeed legitimate, Koopman argues, then Kayne's formulation of anti-symmetry must be modified. Koopman proposes that segments (such as the I's in (32)) can be computed into c-command relations, so that "gloat", dominated by the higher I', asymmetrically c-commands "-ed", dominated by both the higher and lower I' segment.

Thus, Koopman assumes the following modifications to Kayne's c-command requirements:

33. Segments participate in c-command
34. Modified Linear Correspondence Axiom (LCA): the linear order of overt terminal elements corresponds to asymmetric c-command (Koopman 1996, p. 43-44)

Recall from Chapter 2 that Kayne's LCA determined that the linear order of terminal elements corresponds to structural hierarchy, and structural hierarchy is determined by c-command. Kayne, however, defines c-command as only a relation between categories (XPs). Koopman's modification of Kayne's LCA differs from the original only in that X's, as well as full XPs, may determine structural hierarchy and linear order.

Allowing segments to participate in c-command relations, however, forces other structural constraints. If the specifier of IP is filled in structures such as (35), then the computation of linear ordering again becomes problematic:

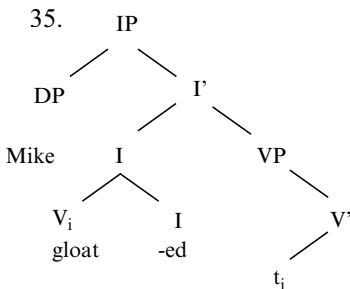

In this structure, I' c-commands the specifier of IP (the DP headed by "Mike"). By the modified LCA, the terminal dominated by I' ("gloated") should thus precede "Mike", which is obviously not the case. This structure, then, is illicit under Koopman's analysis.

Koopman thus proposes the GDCF as a means of getting around this problem. In order to preserve the possibility of segments being used to compute c-command relations, the GDCF rules that either heads or

specifiers can be overtly realized in a projection, but not both. Legitimate configurations are shown below:

36.

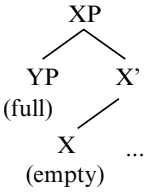

37.

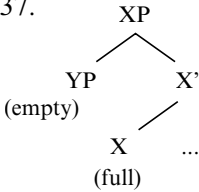

Furthermore, Koopman argues that not only are projections with both overt heads and specifiers blocked, but also projections with both their specifiers and heads empty. This latter restriction is due to visibility requirements: a projection must be semantically activated by the presence of lexical material at some point in the derivation. A projection that has not had any overt lexical material pass through it is thus semantically inactive. In short, Koopman’s theory assumes that the semantic features of a projection must be overtly realized within the projection in which they are generated.

Another consequence of the GDCF is that a number of additional projections must be posited to accommodate the apparent co-occurrence of specifiers and heads in sentences such as “Mike gloated”: if the structure in (35) is illicit because both the specifier and head of IP are filled, there must be an additional projection available above IP for the subject *Mike* to raise into. For semantic reasons, this higher projection must be distinct from that which houses question markers and *wh*-words, for instance.

The GDCF, then, appears to account for the distribution of *cě’ity* and *-dya’* in a consistent way: assuming that *cě’ity* and *-dya’* surface in the specifier and head of NegP, at some point in the derivation, then the constraint against their cooccurrence when higher projections are filled can be simply explained.

### 4.3.3 Irrealis Negation Effects in Clausal Negation

Another distinctive effect of clausal negation – and one which will be used as a diagnostic for syntactic structure in the remainder of this chapter – is its effect on the interpretation of verbs with Irrealis aspect marking. As described in the previous chapter, Irrealis-marked verbs are used to express

future-tense events (38); under the scope of intensional or modal verbs, they receive subjunctive-like readings (39).

38. Y-tòò'oh Gye'eihlly ca'rr  
 irr-sell Mike car  
 "Mike will sell the car"
39. R-càa'z y-too'oh Gye'eihlly ca'rr  
 hab-want irr-sell Mike car  
 "Mike wants to sell the car"

Verbs with Irrealis aspect marking may not undergo standard clausal negation in matrix clauses. Instead, they are negated with a distinct negation pattern with *cě'ity* and *-dya'* adjacent to each other, rather than flanking the verb. This pattern was discussed in detail in the preceding chapter, and is exemplified again in the following example:

40. Cě'ity-dya'-rěng g-wùall-rěng li'ebr  
 neg-dya-3p.prox irr-read-3p.prox book  
 "They will not read the books"

This structure, in contrast to the standard clausal negation structure, is biclausal: the Irrealis verb "read" remains in TP in an embedded clause, while a covert existential verb in the matrix clause is the actual target of negation by *cě'ity*. See Section 3.3.2 for a detailed syntactic and semantic analysis of this construction.

Irrealis verbs may, however, appear with the standard clausal negation pattern in embedded clauses. In this case, they receive indirect imperative, rather than simple future, readings, as seen in the preceding chapter. I will call this the Irrealis Negation Effect:

41. R-e'ihpy Lia Pa'amm làa'rěng  
 hab-tell Ms. Pa'amm 3p.prox  
 "Pam told them
- cě'ity g-wùall-dya-rěng li'ebr  
 neg irr-read-dya-3p.prox book  
 not to read the books"  
 ≠"Pam told them they will not read the books"

The difference between the readings of the Irrealis verb "read" in (40) and (31) results from a difference in modality. While Irrealis verbs negated by Future Negation get the same simple future reading as matrix clause Irrealis verbs (they describe events that both the speaker and hearer assume will be carried out in the actual world), under normal clausal negation, they receive the same subjunctive-like reading of Irrealis verbs under intensional predicates and modals (they describe unrealized events in possible worlds).

SLQZ modal verbs surface above other verbs in SLQZ. Thus, I assume that MoodP, where the expression of mood is triggered and syntactically licensed, is above TP, as argued in the preceding chapter. The fact that movement of Irrealis verbs under negation results in a modal reading of the verb suggests that verbs that move to NegP must also pass through MoodP:

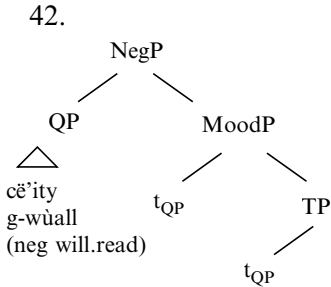

This activates modal features of the verb when they are present, as is the case with the modal aspects such as the Irrealis, which allow both modal and non-modal readings (Lee 1996). In cases in which the verb is marked with one of the non-modal aspects (which lack mood features) and no other expression of non-indicative modality appears, MoodP is absent or inactive.

To sum up, then, there are three notable semantic features of SLQZ clausal negation: it is based upon specifier-head agreement within NegP, it requires further movement of material in spec, NegP to a higher projection (the GDCF), and it requires movement of verbs through MoodP in order to reach this higher projection (as shown by Irrealis Negation effects). These three features will be used to distinguish the basic clausal negation pattern just described from the superficially similar constituent negation pattern also commonly used in SLQZ.

#### 4.4 Constituent Negation

Another frequently used negation pattern involves the negative morpheme *a'ti'*, which may be used to negate both verbal and non-verbal constituents. In this section, the distribution of other fronted constituents in *a'ti'* negation constructions will be used to determine the inventory and ordering of high (CP) level functional projections in SLQZ.

*A'ti'* negation involving verbs or arguments generally results in contrastively focused negative readings, while *a'ti'* negation involving non-verbal predicates does not always force focus readings. *A'ti'* negation is superficially similar to clausal negation: *a'ti'* precedes, and *-dya'* follows, the negated constituent, which may be verbal or non-verbal:



43. A'ti' me's-dya' n-àa Gye'eihlly  
 neg teacher-dya' neut-be Mike  
 "Mike is not a teacher"

On closer examination, however, *a'ti'* negation differs syntactically from clausal negation. First, there are no doubly-filled comp effects in *a'ti'* negation constructions: *-dya'* must always be present, even in structures involving wh-movement:

44. Tu a'ti' me's (\*-dya') n-àa?  
 who neg teacher (\*-dya') neut-be  
 "Who isn't a teacher?"

Second, focus-fronted constituents are disallowed in *a'ti'* constructions, with or without *-dya'*:

45. \*Gye'eihlly a'ti' me's-dya' n-àa  
 Mike neg teacher-dya' neut-be  
 "MIKE isn't a teacher"

This is in direct contrast with clausal negation structures, which do allow focus (in the absence of *-dya'*) as seen in (26).

Fronted constituents, however, are allowed as left-dislocated topics, with the topicalized constituent appearing a second time in the base position:

46. Gye'eihlly a'ti' me's-dya' n-àa Gye'eihlly  
 Mike neg teacher -dya' neut-be Mike  
 "(As for) Mike, he's not a teacher"

This suggests that focused-fronted and left-dislocated topic arguments occupy different syntactic positions, and that left-dislocated topics land in higher positions than focused constituents. Moreover, QPs headed by *a'ti'* raise higher than QPs headed by *cëi'ty*. *Cëi'ty* surfaces below FocP, thus allowing focused constituents to precede it, but *a'ti'* appears either in or above FocP, thus blocking other focused constituents (but still allowing left-dislocated topics, which may surface above FocP):

47.

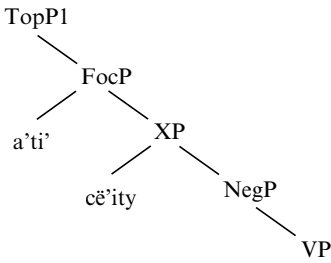

I will assume that the high position in which left-dislocated topics appear, TopP1, is one of two topic positions used in SLQZ. Evidence for another, lower, topic position will be presented later in this chapter. (The presence of topic positions both above and below FocP has been argued for in Italian by Rizzi (1997).)

The higher landing position of *a'ti'* also accounts for the fact that it invariably cooccurs with the negative element *-dya'*. Since *a'ti'* is always forced to raise out of NegP (for reasons to be elaborated in the following sections), the Generalized Doubly-Filled Comp Filter never requires *-dya'* (in the head of NegP) to be suppressed.

A third difference between *a'ti'* negation and clausal negation is that there are no Irrealis Negation effects with *a'ti'*. Irrealis verbs under *a'ti'* negation don't get modal readings:

48. A'ti' y-tò'oh-dya' Gye'eihlly ca'rr  
 neg irr-sell-dya' Mike car  
 "Mike won't SELL a car (he'll buy one)"

Recall from the previous section that the modal readings of Irrealis verbs under clausal negation are triggered by raising of the VP through MoodP on the way to NegP. The lack of modal readings of verbs under *a'ti'* negation suggests that either *-dya'* and the verb are lower in this context than in clausal negation, or that for some reason the verb is not required to pass through MoodP in *a'ti'* negation constructions.

These patterns, however, raise questions about where negation is licensed in constituent negation constructions: if *-dya'* is the head of NegP, and NegP is above MoodP (as argued in the previous section), then the non-modal interpretation of the negated Irrealis verb in (48) is unexplainable. Likewise, the absence of doubly-filled comp effects in *a'ti'* constructions suggests that *a'ti'* raises higher than *cë'ity*, *-dya'* is generated lower in *a'ti'* constructions than in *cë'ity* constructions, or both.

#### 4.4.1 The Case for NegP2

I will propose that constituent negation is licensed in a lower negative projection distinct from that in which clausal negation is licensed: in brief, SLQZ has two NegPs, a high one above MoodP in which clausal negation is realized (NegP1) and a lower one, below MoodP but above TP, in which constituent and focus negation is realized (NegP2). The placement of NegP2 directly above TP is suggested by the fact that negated non-verbal constituents always appear directly above the verb, which sits in spec, TP, as seen in the following examples:

49. A'ti' me's-dya' n-àa Gye'eihlly  
 neg teacher dya is Mike  
 "Mike is not a teacher"
50. A'ti' cuann tenedoor-dya' b-da'uw Gye'eihlly gueht  
 neg with fork dya' perf-eat Mike tortilla  
 "Mike didn't eat tortillas with a fork"

On the assumption that *-dya'* is base-generated as the head of NegP and remains in situ throughout the derivation (as in the clausal negation cases), NegP2 would have to be above TP, but below MoodP.

The existence of two co-existing NegPs was independently proposed for the Romance languages by Zanuttini (1991), who argues that the higher NegP1 takes tensed constituents as its complements, while the lower NegP2 takes (non-tensed) VP as its complement. Thus, in (48), *-dya'* surfaces below NegP1 in the head of NegP2.

The idea that *a'ti'* negation is licensed in NegP2, which (following Zanuttini 1991) takes non-tensed complements, is consistent with the fact that *a'ti'* negates both non-verbal constituents and contrastively focused verbs. Contrastive negation of verbs differs from clausal negation of verbs in that in the former case, tense takes scope over negation, while in the latter, negation takes scope over tense.

This contrast can be seen in the following two English examples. In the first, a standard case of clausal negation, the existence of an entire past event of eating is being negated. In the second case, in which *eat* is given contrastive focus, it is not the event (including temporal frame) itself being negated, but only the content of the action that took place during this event. In syntactic terms, only the verb, and not the tense features assigned to the verb, is being negated:

51. Mike didn't eat  
 "there is no past eating event involving Mike"
52. Mike didn't EAT (he drank)  
 "In some past event involving Mike, it was not the case that he ate (he did something else)"

Thus, while in clausal negation, negation takes scope over both tense and the lexical content of the verb, in constituent/focus negation, negation is under the semantic scope of tense, but over the negated constituent itself.

Thus, the relative placement of the two negative projections is as follows:

53.

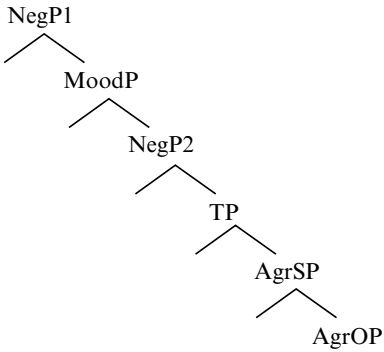

I assume that when NegP1 is active, NegP2 is absent, and vice versa. This is consistent with the requirements of the GDFC, which states that projections can only be active if either their heads or specifiers (but not both) contain overt material at some point in the derivation. An inactive projection that doesn't attract any other constituent, then, would be illicit.

#### 4.4.2 Proposed Structure

In this section, I will describe the proposed structures for *a'ti'* negation of both verbal and non-verbal constituents. While essentially parallel, the slight differences between these structures provide revealing diagnostics for the existence of additional preverbal projections in SLQZ, as well as diagnostics for more general conditions on movement in SLQZ.

I assume that *a'ti'* negation of both verbal and non-verbal constituents originates from the same basic structure: *a'ti'* is generated in a QP taking the negated constituent as its complement, parallel to the relation between the clausal negation marker *cë'ity* and negated verbs. I will consider first the case of contrastively focused verbs under *a'ti'*, such as that in (48):

54.

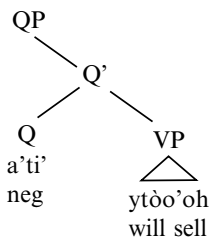

From here, the QP headed by *a'ti'* raises to TP to check the tense features on the VP remnant:

55.

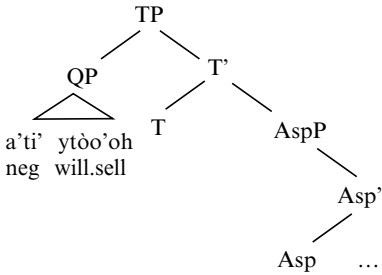

*-dya'* is generated as the head of NegP2 in *a'ti'* negation. The *a'ti'*-verb complex raises to spec, NegP2:

56.

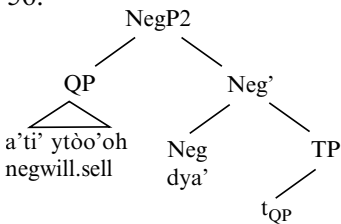

This configuration checks the negative features on *a'ti'* via spec-head agreement with *-dya'*. However, it violates the GDCF since both the head and specifier of NegP2 are filled simultaneously. The QP headed by *a'ti'* needs to raise out of NegP2 into a higher projection, and thus raises to FocP. This both contributes to the (usual) focused reading of the negated expression, and accounts for the fact that focused constituents can't appear with *a'ti'*.

There is evidence for the existence of the additional projections marked as XP and YP in the tree above, between TP and FocP. Evidence for these projections will be presented in the following sections.

57.

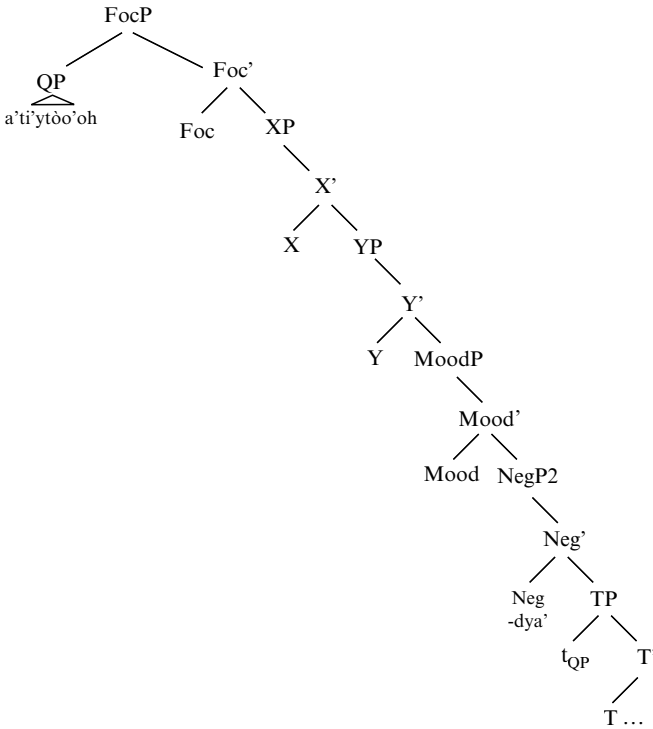

The preceding derivation, however, raises the question of how it is possible for the QP to raise to FocP while bypassing MoodP: since *a'ti'* negation does not trigger Irrealis Negation effects, I had argued previously that verbs negated by *a'ti'* do not pass through MoodP. The difference between focus negation with *a'ti'* and clausal negation with *cě'ity*, which does trigger Irrealis Negation effects, can be explained in terms of Relativized Minimality.

Movement into NegP can be considered A-movement in SLQZ, along the lines of movement of verbs into T: this is supported by the fact that simple clausal negation actively interacts with purely morphological and structural processes such as verb movement and affix-hopping in English and other languages. (One possibility is that the VP remnant that raises into spec, NegP2 in (57) turns NegP2 into a derived A-position.) Thus, movement of a QP headed by the clausal negation marker *cě'ity* into NegP1, generated above MoodP, would be A-movement, and will consequently be required to target all intervening A-positions, including MoodP.

Movement of NegP into FocP or higher positions in the CP domain, however, is A'-movement. Since NegP2 is below MoodP, A-movement into NegP by constituents negated by *a'ti'* takes place below MoodP. Movement of the negated constituent out of NegP2 into FocP to check focus features is A'-movement, and thus bypasses MoodP, which I will assume is an A-position.

The possibility that *a'ti'* negation bypasses MoodP is supported by the fact that *a'ti'* negation may take place in sentences in which MoodP is activated by another constituent:

58. A'ti' Gye'eihlly-dya' nuhnguehll g-a'c studya'aann-za'c  
 neg Mike-dya' supposed.to irr-be student-good  
 "MIKE isn't supposed to be a good student."

In this structure *nuhnguehll*, "supposed to" is what ML label a "modal auxiliary": like English modal auxiliaries, it has an invariant Neutral tense/aspect form and does not take any subject marking. SLQZ modal auxiliaries select Irrealis verbs with modal readings. I leave aside the exact structural details of modal auxiliary constructions, but it is clear that modality is independently encoded by the auxiliary, the Irrealis verb, or both in (58). Since MoodP is active, and occupied by the verb or the auxiliary, it is clear that the *a'ti'* complex is able to raise licitly past a filled MoodP.

This structure also accounts for the lack of DFC effects in *a'ti'* negation, since *a'ti'* and *-dya'* always surface at some distance from each other, as seen in (57).

#### 4.4.3 Non-Verbal Negation with *a'ti'*

Now I turn to *a'ti'* negation involving non-verbal constituents. These constructions are parallel to verbal *a'ti'* negation: negation targets NegP2 and involves further movement of the negated constituent out of NegP2. I will show, however, that here is a slight difference between structures in which nonverbal predicates (such as 59) are negated, and those in which other constituents (such as 60) are:

59. A'ti' me's-dya' n-àa Gye'eihlly  
 neg teacher-dya' neut-be Mike  
 "Mike is not a teacher"
60. A'ti' Pamm-dya' z-èe làa' Cris z-èe  
 neg Pam-dya' def-go foc Chris def-go  
 "PAM didn't leave, Chris did"

In these constructions, as in the verbal negation cases, *a'ti'* is base-generated as the head of a QP taking the negated constituent as its complement. The complex formed by *a'ti'* and its complement raises to NegP2, as in the verbal negation cases, and then, in the cases where the negated constituent is interpreted contrastively, to FocP:

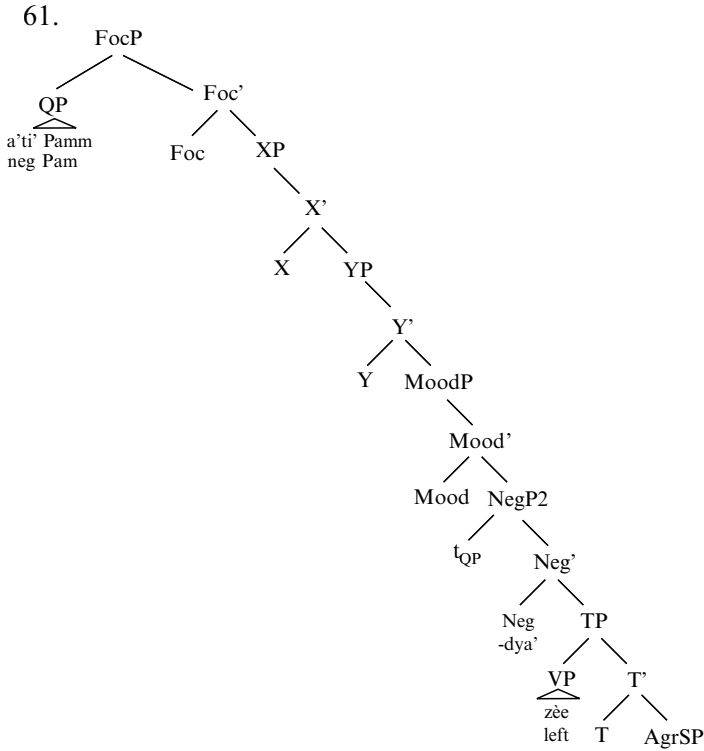

Nonverbal predicates negated with *a'ti*, however, do not normally receive contrastive focus readings, and overt focus movement in SLQZ is generally reserved for purely contrastive, as opposed to presentational, focus. Thus, negated nonverbal predicates must raise to some other position above NegP2.

In the following sections, I will show that there is independent evidence for the existence of such a position, and independent motivation for nonverbal predicates to make use of it.

#### 4.4.4 *A'ti'* in Matrix and Relative Clauses: Evidence for PredP

The first piece of evidence for the existence of the projection XP between FocP and TP comes from the interaction of focus and *a'ti'* in matrix and relative clauses. In the previous section, I argued that *a'ti'* raises to focus: this is suggested by the fact that negative sentences with *a'ti'* disallow focus-fronted constituents:

62. \*Gye'eihlly a'ti' me's-dya' n-àa  
 Mike neg teacher-dya neut-be  
 "MIKE isn't a teacher"



Relative clauses, however, reveal a difference in distribution between *a'ti'* and focus-fronted constituents: while focus-fronted constituents are disallowed in relative clauses (64) constituents negated by *a'ti'* are allowed (65):

63. A comiied [nih r-yu'làà'z Gye'eihlly] b-èè'b lohoh me's  
 top food [rel hab-like Mike perf-lie on table  
 "The food that Mike likes is on the table"
64. \*A comiied [nih Gye'eihlly r-yu'làà'z] b-èè'b lohoh me's  
 top food [rel Mike hab-like ] perf-lie on table  
 "The food that MIKE likes is on the table"
65. Bùnny [nih a'ti' campesyenn-dya'n-àa] nu'uh rèè'  
 person rel neg farmer-dya' neut-be neut-exist here  
 "The man who's not a farmer is here"

This suggests that *a'ti'* does not occupy FocP in relative clauses, but rather, appears below FocP, but above TP. (Since the next position above *a'ti'* in (65) is occupied by the relative marker, it is unlikely that *a'ti'* occupies a position higher than FocP.)

Further evidence for a position between FocP and TP—and a hint to its semantic and syntactic function—comes from the fact that predicate nominals may appear preverbally in relative clauses, while contrastively focused constituents can't:

66. A bùnny nih campesye'nn n-àa nu'uh rèè'  
 top man rel farmer neut-be neut-exist here  
 "The man who's a farmer is here"
67. \*Bròò'oh ra bx:àady nih mnii'iny b-da'uh  
 big pl grasshopper rel boy perf-eat  
 "The grasshopper that THE BOY ate are big"

Thus, predicate nominals land lower than FocP in relative clauses, but must still be above TP, since they precede the copula. The existence of a distinct projection for the licensing of nonverbal predicates (PredP) has been independently proposed for Dutch and other languages (Kayne 1997, Zwart, 1993). In SLQZ, predicate nominals/adjectives generally appear above tensed copulas; this suggests PredP is fairly high in SLQZ (above TP). I will thus assume that the preverbal projection XP in (57) and (61) is, in fact, PredP, and is the projection into which negated nonverbal predicates surface in relative clauses:

68.

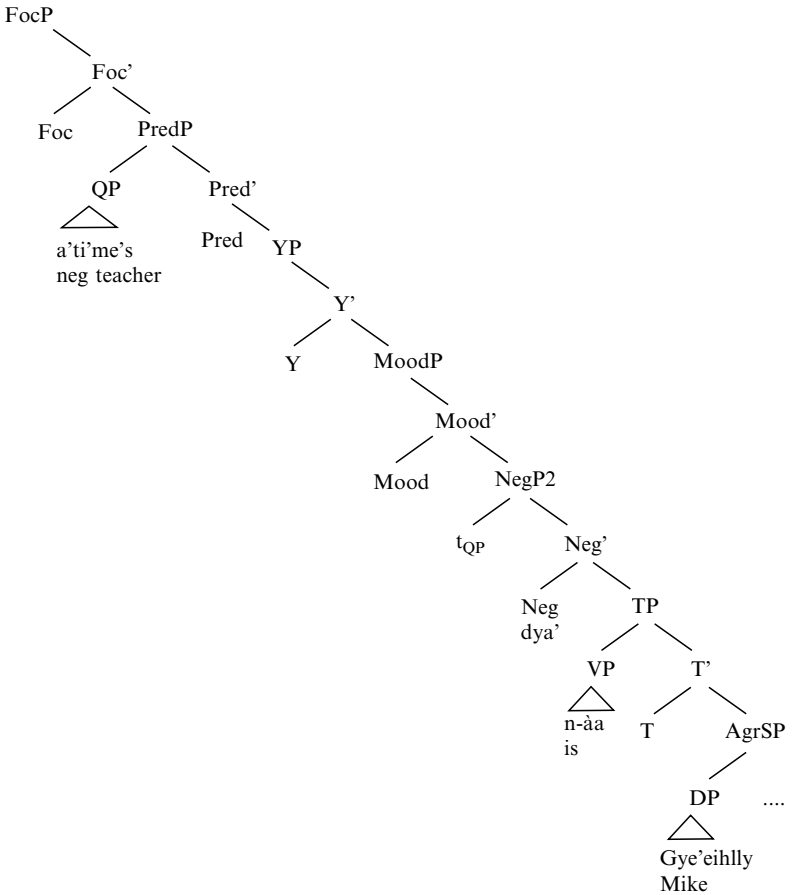

Evidence that PredP is not only above TP, but above MoodP, comes from the fact that fronted predicate nominals may occur in sentences in which Irrealis verbs receive modal readings:

69. R-càa'z Gye'eihlly nnsini'cy g-ahc zhi'ny zhya'p Gye'eihlly  
 hab-want Mike intelligent irr-be child girl Mike  
 "Mike wants his daughter to be intelligent."

In this example, the fronted predicate “intelligent” precedes an Irrealis verb with a subjunctive, rather than simple future, reading. Since subjunctive readings result from movement through MoodP, this structure suggests that the preverbal position hosting the adjectival predicate – PredP – is above MoodP.

### ***The Interaction of FocP and PredP***

Non-verbal predicates most often appear preverbally, although they may also appear postverbally. In almost all cases, nonverbal predicates, like constituents negated with *a'ti'*, behave as if they were in FocP when they appear preverbally. Like contrastively focused constituents, they block other preverbal material, such as *wh*-words and focus-fronted arguments:

70. Tu n-àa behts-ëng?  
 who neut-be brother-3s.prox  
 “Who is his brother?”

71. \*Tu behts-ëng n-àa?  
 who brother-3s.prox neut be  
 “Who is his brother?”

Fronted adjectival, as well as nominal, predicates block *wh*-movement:

72. Ngàa'ah n-àa mannsaan  
 green neut-be apple  
 “The apple is green”

73. Xi mannsaan n-àa ngàa'ah?  
 what apple neut-be green  
 “Which apple is green?”

74. \*Xi mannsaan ngàa'ah n-àa?  
 what apple green neut-be  
 “Which apple is green?”

Embedded clauses (apart from relative clauses and complements of certain modal expressions, which I will leave aside here) generally allow focused arguments. *Wh*-words, however, cannot be extracted from embedded clauses that contain focused constituents:

75. Xi r-ralloh liu' [g-a'u Gye'eihlly t]?  
 what hab-think 2s irr-eat Mike?  
 "What do you think Mike will eat?"
76. \*Xi r-ralloh liu' [Gye'eihlly ga'u t]?  
 what hab-think 2s Mike irr-eat  
 "What do you think MIKE will eat?"

In (76), wh-movement of *xi* "what" out of the embedded clause is blocked by the presence of *Gye'eihlly* "Mike" in the preverbal focus position.

The possible interpretation of wh-questions is also affected by focus island effects. In (77), for instance, *x:a mo'od* "how" (on its manner interpretation) may be interpreted as modifying or questioning the embedded clause:

77. X:a mo'od r-ralloh liu' [y-zëhny Gye'eihlly]?  
 what way hab-think 2s.inf irr-arrive Mike  
 "How do you think Mike will arrive?"  
 [e.g., "By what form of transportation do you think Mike will arrive?"/"What makes you think MIKE will arrive?"]

In (78), the subject of the embedded clause ("Mike") appears in the preverbal focus position. In this case, *x:a mo'od* "how" cannot be construed as questioning the embedded clause:

78. X:a mo'od rralloh liu' [Gye'eihlly y-zëhny]?  
 what way hab-think 2s.inf Mike irr-arrive  
 "How do you think MIKE will arrive?"  
 [e.g., "What makes you think MIKE will arrive?"/"By what form of transportation do you think MIKE will arrive?"]

Thus, *x:a mo'od* "how" is blocked from raising out of the embedded clause. If it is indeed generated there, the derivation crashes. Because the wh-expression cannot escape the embedded clause, it cannot receive the same interpretation as (77), in which "how" can be interpreted as questioning material in the embedded clause.

The only way for wh-movement to occur, and for the sentence to be grammatical, is to generate *x:a mo'od* in the matrix clause, where no preverbal material blocks its movement. If this is the case, then *x:a mo'od* should only be interpretable as questioning material in the matrix clause. This prediction is borne out, as seen by the single possible interpretation of (78). In (78), *x:a mo'od* "how" can only question the addressee's thinking, not Mike's arriving. Thus, there are interpretive, as well as structural, effects that result from the islands formed by focused constituents.

Inside relative clauses, however, the distinction between contrastively focused constituents and preverbal nonverbal predicates becomes clear: the former are blocked in relative clauses, while the latter are allowed:

79. Ndyo'oh mnii'iny nih b-da'uh bx:àady  
 fat child rel perf-eat grasshopper  
 "The child who ate grasshoppers is fat"
80. \*Ndyo'oh mnii'iny nih bx:àady b-da'uh  
 fat child rel grasshopper perf-eat  
 "The child who ate GRASSHOPPERS is fat"
81. A bùunny nih campesye'nn g-uhc nu'uh rèè'  
 top man rel farmer perf-be neut-exist here  
 "The man who was a farmer is here"

This patterning is vaguely reminiscent of V2 effects in Germanic languages: in these languages, V raises to C (the highest head in the clause) when no complementizer is present, but stays low when an overt C is present.

The fact that focused constituents and predicate nominals show different distribution in relative clauses supports the view that FocP and PredP are distinct projections, with PredP being lower than FocP, but still above TP. This raises the question, however, of why they both appear in FocP when not in relative clauses: If *a'ti'* and nonverbal predicates may be below FocP in relative clauses, why not in other contexts?

#### 4.4.5 The Focus Criterion

Another context in which a similar asymmetry between relative clauses and regular matrix and embedded clauses occurs is in the case of *-zhya'* cliticization. As described in the previous chapter, fronted constituents modified by the modal clitic *-zhya'* block focus movement in matrix clauses, and thus were argued to surface in FocP themselves:

82. Lohs Aa'nngl-zhya' n-u'-rëng  
Los Angeles-might neut-exist-3p.prox  
 "Los Angeles might be where they are (not somewhere else)"

83. \*Gye'eihlly Lohs Aa'nngl-zhya' n-u'uh  
 Mike Los Angeles-might neut-exist  
 "MIKE might be in Los Angeles"

However, constituents with *-zhyá'* may appear preverbally in relative clauses:

84. A zhyàa'p nih Lia Olieb-zhya' cě'ity r-umbèe' n-u'uh rèe'  
 top girl that Ms. Olivia-might neg hab-know neut-exist here  
 "The girl that Olivia might know/that might know Olivia is here"

This suggests that constituents modified by *-zhyá'*, like predicate nominals, are required to raise to FocP in all cases except in relative clauses, where they obligatorily remain below FocP.

The inability of focused constituents to appear in relative clauses stems from the fact that relative clauses inherently involve *wh*-movement from inside the relative clause to the specifier of the relative clause. This movement either involves a covert operator base-generated inside the relative clause and coindexed with a relative clause head base-generated higher in the structure (as traditionally assumed) or overt movement of the relative clause head itself from a base-generated position inside the relative clause to its surface position outside of it (Kayne 1994, Vergnaud 1985).

*Wh*-movement itself involves the focus projection, and is blocked by filled FocPs, as seen by the preceding data. This has also been noted in Hungarian, among other languages; cf. Horvath 1986. (However, as I will make clear in the next chapter, while *wh*-movement involves focus movement, *wh*-movement and focus movement are not a single, interchangeable process.) Thus, in relative clauses, FocP is always occupied by the trace of the *wh*-moved constituent. Because FocP is always filled in relative clauses, nonverbal predicates cannot occupy it: they must either remain in their base post-verbal positions, or must raise only as far as PredP.

But what about the non-relative-clause cases? Why is movement of preverbal non-verbal predicates to FocP required? That is, why can't focused constituents co-occur with preverbal predicates in PredP, since movement of nonverbal predicates to FocP is clearly not necessary for them to be licit, as seen by their presence in PredP inside relative clauses?

I will propose the following: The fact that movement to FocP is obligatory in the absence of other focused constituents or *wh*-words suggests that FocP has a strong tendency to attract constituents, and that SLQZ prefers for FocP to be filled whenever possible. Thus, I will argue that the following condition holds:

85. Focus Criterion: FocP must be overtly filled at some point in the derivation

This can be motivated semantically, as well as empirically. Focus serves to express new information, and all linguistic expressions involve conveyance of new information. In the absence of contrastively focused information (such as focused arguments), the entire sentence itself represents a proposition to be contrasted against previous background information.

Thus, the Focus Criterion is reflected in the syntax in the following way: When a constituent is contrastively focused, it raises to spec, FocP. In the absence of contrastive focus, the entire clause (TP) raises to FocP (irrelevant projections omitted):

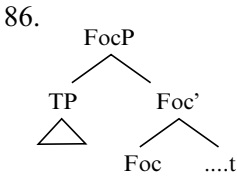

When a non-verbal predicate or a negated non-verbal predicate raises to PredP, it undergoes further movement itself to satisfy the Focus Criterion. This effectively blocks the possibility of additional focused constituents within the clause:

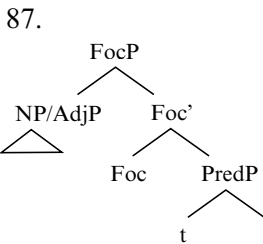

Movement of the XP predicate itself to FocP, rather than movement of the entire clause dominated by PredP, is motivated reasons of economy: In his (1992, 1995) Minimalist program, Chomsky argues that multiple movements of a single constituent constitute formation of a single chain, and thus count as a single move. This argument was motivated by need to reconcile the often-conflicting requirements that syntactic structures be derived by means of the shortest moves possible (Chomsky's "Shortest Moves" condition) and the smallest number of moves possible (the "Fewest Steps" condition). These requirements come into conflict in a number of derivations, such as successive-cyclic wh-movement, in which wh-words move long distances by landing in a number in intermediate positions: while this is consistent with "Shortest Move", it violates "Fewest Steps". Chomsky's chain-formation condition, then, reconciles this conflict.

Returning to SLQZ, this would mean that movement of a non-verbal predicate to PredP, then subsequent movement of TP would result in the formation of two separate chains, thus two moves. This is a more costly option in Minimalist terms than movement of a non-verbal predicate into PredP, then into FocP, which would count as only a single move. The co-occurrence restrictions between fronted nonverbal predicates and focus support this: if the preverbal predicate were required to only raise as far as PredP, nothing would stop other contrastively focused constituents from raising past it into FocP. Certainly, no semantic factors would prevent this. Thus, this co-occurrence restriction must be driven by strictly syntactic considerations.

The Focus Criterion also explains the relative rarity of sentences with multiple preverbal constituents, despite the existence of numerous preverbal projections: because Minimalist requirements force any constituent raised to a preverbal position to also raise though FocP to satisfy the Focus Criterion, the presence of additional constituents in Focus is thus blocked. Thus, fronted non-verbal predicates and fronted constituents with the modal clitic *-zhya'* cannot co-occur with other focused constituents, even though no semantic factors would prevent this.

In this section, then, I have argued for two points: first, for the existence of a preverbal projection PredP directly below FocP; and second, for a general requirement that FocP be overtly activated in all SLQZ clauses (the Focus Criterion). In the next section, I will present evidence for the second preverbal projection beneath focus posited in the trees in (57) and (61): TopP2, a topic projection that occupies the position directly below PredP.

#### 4.4.6 Evidence for TopP2: The Interaction of Topics and Negation

Now I turn to the identity of the projection marked YP in the preceding trees. I will show that this projection is the lower of two topic projections in SLQZ. SLQZ has two types of topics: left-dislocated topics, which involve a resumptive copy of the topic in the body of the clause, and topics preceded by the topic marker *a* :

88. Gye'eihlly xi b-da'uh Gye'eihlly?  
 Mike what perf-eat Mike  
 "(As for) Mike, what did he eat?"



89. A Gye'eihlly b-da'uh bx:àady  
 TOP Mike perf-eat grasshopper  
 "Mike (whom we were talking about) ate grasshoppers"

Left-dislocated topics are high. They may precede focus-fronted constituents and *wh*-words (as seen in the preceding example); *a*-topics appear preverbally (thus above TP), but surface below FocP (evidence for this will be presented shortly.) I thus assume two independent topic projections: TopP1, which is above FocP and houses left-dislocated topics; and TopP2, which houses *a*-topics.

The interaction of *a*-topics with verb movement gives suggestive evidence as to the exact location of TopP2. As noted in the previous chapter, *a*-topics block the raising of verbs past the adverb *al* "already":

90. A Gye'eihlly al b-da'uh bx:àady  
 top Mike already perf-eat grasshopper  
 "Mike already ate the grasshoppers"
91. \*A Gye'eihlly b-da'uh al bx:àady  
 top Mike perf-eat already grasshopper  
 "Mike already ate the grasshoppers"

Contrastively focused arguments, on the other hand, do not block such movement.

92. Gye'eihlly al b-da'uh bx:àady  
 Mike already perf-eat grasshopper  
 "MIKE already ate the grasshoppers"
93. Gye'eihlly b-da'uh al bx:àady  
 Mike perf-eat already grasshopper  
 "MIKE already ate the grasshoppers"

Thus, TopP2, the licensing projection for *a*-topics, occupies a position lower than focus. (Potentially, TopP2 could be the position targeted by VP remnants moving past *al*, "already".) Also notable is the fact that *a*-topics cannot co-occur with negation (either clausal or constituent):

94. \*A Gye'eihlly cē'ity b-da'uh-dya' bx:àady  
 top Mike neg perf-eat-dya' grasshoppers  
 "Mike didn't eat the grasshoppers"

95. \*A Gye'eihlly a'ti' doctoor-dya' n-àa  
 top Mike neg doctor-dya' neut-be  
 "Mike isn't a doctor"

The fact that *a*-topics cannot co-occur with *a'ti'* negation is consistent with the argument that *a'ti'* generally raises through PredP to FocP, and TopP is below both PredP and FocP. The fact that they cannot co-occur with clausal negation (that is, with *cë'ity*) also supports the idea that TopP may be even lower than PredP: Recall from Section 2.2 that clausal negation structures do allow focus-fronted constituents:

96. Gye'eihlly cë'ity b-da'uh bx:àady  
 Mike neg perf-eat grasshoppers  
 "MIKE didn't eat the grasshoppers"

When focus appears with clausal negation, *-dya'* is generally dropped, as previously noted. This effect was argued to be a result of the GDCF, whereby *-dya'*, the head of NegP, is dropped so that *cë'ity*, the specifier of NegP, may remain in NegP1 when specifiers of higher projections are occupied and prevent its further movement.

It is possible (though less common), however, for *-dya'* to appear overtly in clausal negation cases with focus fronting:

97. Gye'eihlly cë'ity b-da'uh-dya' bx:àady  
 Mike neg perf-eat-dya'grasshoppers  
 "MIKE didn't eat the grasshoppers"

This suggests that *cë'ity* and the negated verb have the option of raising into a projection higher than NegP1, but lower than FocP, when overtly focused constituents appear. (It is unclear why this option is dispreferred.) This position could either be PredP or TopP.

Either possibility would be consistent with the idea that *a*-topics surface in positions below FocP. If *cë'ity* raised into PredP, the co-occurrence restriction between *cë'ity* and *a*-topics could be accounted for by the fact that *a*-topics need to occupy either PredP itself or some lower preverbal position. As previously argued, however, PredP is reserved for the licensing of nonverbal (untensed) arguments: thus, it would be inconsistent to posit PredP as a possible landing position for *cë'ity* and negated verbs in clausal negation structures.

If *cë'ity* and the verb raised into TopP, below PredP, however, the inability of *a*-topics to appear with clausal negation can be accounted for in similar terms: both the fronted topic and *cë'ity* are competing for the same position (spec, TopP), and thus cannot appear together.

The possibility of *cë'ity* and the verb occupying TopP is supported by the fact that the topic marker *a* may also precede verbs. (It is unclear what the semantic contribution *a* makes in these contexts):

98. A b-ii'lly Gye'eihlly li'ebr  
 top perf-read Mike book  
 "Mike read the book"

While focused constituents may not intervene between fronted wh-words and verbs, the topic marker *a* may appear preverbally after wh-words:

99. Tu a b-ii'lly li'ebr?  
 who top perf-read book  
 "Who read the book?"

This supports the idea that constituents modified by the topic marker *a*, including verbs, surface in their own projection (TopP) below both FocP and PredP. This is also consistent with the argument that the clausal negation marker *cë'ity* and the negated verb can raise into TopP.

The possibility of clausal negation structures both with and without *-dya'* raises a more general question: if syntactic structures converge on the most economical derivation possible, why should structures like (97), which involve additional movement into TopP, be allowed to co-exist in SLQZ along with more economical structures such as (96)? A reasonable conjecture would be that the two structures differ in semantics or pragmatic usage. This would be consistent with Minimalist assumptions that movement is driven by the feature-checking requirements of the moved constituent, and that functional projections contain semantic or structural features that satisfy these requirements. Movement of a negated constituent into TopP in (97), then, must necessarily involve checking of a Topic feature encoded in the negated constituent. Movement into TopP is not motivated, and thus, not permitted, in the absence of Topic features. Thus, the negated constituent in (96), which surfaces in NegP1, can be assumed to lack a Topic feature.

In short, there is evidence for an additional functional projection below FocP and PredP—TopP—that houses fronted topics and serves as a potential landing spot for negated constituents in certain syntactic configurations. The inventory of preverbal functional projections argued for in this chapter, then, is as follows:

100.

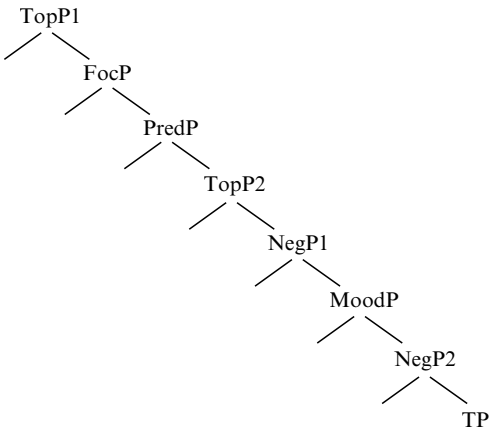

Moreover, it can be shown that movement into any of the numerous functional projections argued for in this section is motivated by both the structural requirements of Antisymmetry and the feature-checking requirements of the moved constituents. Convergent derivations must satisfy both sets of requirements.

## 4.5 Existential Negation: the *Tè'bag* Construction

The third negation construction I will discuss is existential and indefinite negation: that is, the formation of negative constructions such as *no X*, *nobody*, and *nothing*. This construction, which is more complex than those previously discussed, will shed light on a number of other grammatical constructions in SLQZ, such as the expression of indefiniteness and quantification. It will also show that VP-raising can account for not only the syntactic behavior of SLQZ, but some semantic behavior as well. I will begin this section with a descriptive overview of these constructions, then move to a syntactic analysis.

### 4.5.1 Negative Indefinites

In constructions expressing negative indefinites (such as *nothing*, *nobody*, and *nowhere*), *tè'bag* and a *wh*-word directly precede the verb, and *-dya'* directly follows the verb:

101. *Tè'bag calii ch-o'o-dy-ënn izhih*  
 no where irr-go-dya'-1p tomorrow  
 "We won't go anywhere tomorrow"

102. Tèe'bag tu g-a'uw-dya' gueht  
 no who irr-eat-dya' tortilla  
 "No one will eat tortillas"

This closely parallels the formation of non-negative indefinites (such as *something*, *someone* etc.), which are formed with the verb *nu'uh* "exist" followed by a *wh*-word and a verb taking the indefinite as an argument:

103. N-u'uh tu b-da'uh gueht  
 neut-exist who perf-eat tortilla  
 "Someone ate tortillas"

*Tèe'bag* may negate more than one argument simultaneously:

104. Tèe'bag tu xi cay-a'uw-dya'  
 no who what prog-eat-dya'  
 "No one is eating anything"
105. Tèe'bag tu cali ny-ied-dya'  
 no who where subj-go-dya'  
 "No one went anywhere"

No constituents may appear between the *wh*-indefinite and the verb in negative indefinite constructions:

106. \*Tèe'bag xi Gyeeihlly n-yauw-dya'  
 no what Mike subj-eat-dya'  
 "Mike didn't eat anything"

The use of *wh*-words as indefinite pronouns in *tèe'bag* negation is reminiscent of similar constructions in numerous languages, such as Chinese (Cheng 1991, Li 1992), Tzotzil (Aissen 1992), Dutch (H. Koopman, p.c.) and Western Apache (Potter 1997), in which *wh*-words under the scope of negation are interpreted as indefinite pronouns or negative polarity "any", rather than as question markers. I will return to examine these parallels more closely later in this chapter.

#### 4.5.2 Existential Negation

Existential negation constructions are formed with the negative word *tèe'bag* and a *wh*-word that serves as an indefinite marker referring to the negated constituent. In these constructions, the *wh*-indefinite corresponds in animacy to the negated constituent. The *wh*-word is followed by the negated nominal itself, then the negative clitic *-dya'*:

107. Tèe'bag tu studya'aann-dya' b-da'uw pap  
 no who student-dya' perf-eat potatoes  
 "No student ate potatoes"
108. Tèe'bag xi gueht-dya' b-da'uw-a'  
 no what tortilla-dya' perf-eat-1s  
 "I ate no tortillas"

This construction differs from that of negative indefinites in that *-dya'* follows the negated nominal itself, rather than the verb. In the next section, I will discuss the semantic motivation for this difference.

### 4.5.3 Semantic Correlates

The differences in structure between the existential negation constructions in (101-102) and the negative indefinite constructions in (107-108) reflect differences in the semantic structure of the events involved. Thus, the preceding two negative indefinite examples can be paraphrased as follows:

109. Tèe'bag tu studya'aann-dya' b-da'uw pap  
 no who student-dya' perf-eat potatoes  
 "No student ate potatoes"  
 "There exists no x, x a student, such that x ate potatoes"
110. Tèe'bag xi gueht-dya' b-da'uw-a'  
 no what tortilla-dya' perf-eat-1s  
 "I ate no tortillas"  
 "There exists no x, x a tortilla, such as I ate x"

In these cases, the value of *x* is restricted: existential negation only holds of *x* if *x* has the property of being a student in (109), for example. Thus, the negated constituent serves as the restrictor on quantification. The scope of negation appears to be reflected in the placement of the negative elements *tèe'bag* and *-dya'*: *tèe'bag* precedes, and *-dya'* directly follows, the nominal that serves as the restrictor.

In the negative existential constructions (111-112), in contrast, there is no explicit restrictor on quantification. This is made explicit by the glosses below:

111. Tèe'bag tu g-a'uw-dya' gueht  
 no who irr-eat-dya' tortilla  
 "No one will eat tortillas"  
 "There exists no x such that x eats tortillas"

112. *Tèe'bag xi cay-a'uw-dy-a'*  
 no what prog-eat-dya'-1s  
 "I'm not eating anything"  
 "There exists no x such as I'm eating x"

In these cases, *x* is not restricted to having a particular property, as it is in (109-110). The negation can be interpreted as taking scope over the entire event: (111) can be paraphrased "There will be no event of anyone eating tortillas" and (112) as "There is no event of me eating anything."

The postverbal position of *-dya'* is semantically motivated by the fact that verbs in SLQZ are in fact raised VPs. If inflected verbs in SLQZ are indeed VPs, not V heads, then they contain the traces of raised arguments. These traces could be treated as variables that can be bound by their raised antecedents and/or quantifiers such as *tèe'bag*.

Assuming that nonspecific indefinites reconstruct into VP at LF and are interpreted in the nuclear scope and bound by existential closure (as proposed by Diesing 1992), then *tèe'bag* and *-dya'* can be seen as negating the entire event denoted by the VP and its reconstructed indefinite arguments. In other words, (111) can alternately be glossed "there was no event of anyone eating tortillas". Thus, the postverbal position of *-dya'* reflects the fact that negation in these constructions takes scope over an entire event, rather than a restrictor of quantification.

Positing inflected verbs as VPs also makes the examples in (107-108) consistent syntactically with those in (101-102): in both cases, *tèe'bag...-dya'* can be seen as directly preceding and following phrasal projections, rather than a phrasal projection in one case and a verbal head in another.

#### 4.5.4 Towards a Syntactic Structure for *Tèe'bag* Constructions

This section presents a syntactic analysis of these constructions. First, I will examine other non-interrogative uses of *wh*-words in SLQZ. Then, I will review common features of *wh*-indefinites in other languages, and examine how analyses made for these languages can be applied to SLQZ. From this point, I will develop a detailed syntactic structure for the *tèe'bag* constructions previously described.

##### ***Wh*-Indefinites and Non-Interrogative *Wh*-Words in SLQZ**

As previously noted, *wh*-words are also used as indefinite pronouns in non-negative existential constructions with the verb *nu'uh*: "exist". These structures are strikingly similar to the *tèe'bag* constructions with negated indefinites: for one, *nu'uh* may take scope over more than one argument (as may *tèe'bag*), and the order the indefinites appear in is fixed:

113. N-u'uh tu xi b-da'uw  
neut-exist who what perf-eat  
“Someone ate something”
114. \*N-u'uh xi tu b-da'uw  
neut-exist what who perf-eat  
“Someone ate something”
115. Tèe'bag tu xi cay-a'uw-dya'  
no who what prog-eat-dya'  
“No one is eating anything”

The appearance of more than one preverbal wh-word in *nu'uh* and *tèe'bag* constructions is surprising, since SLQZ only marginally allows multiple wh-questions (and some speakers do not allow them at all). This suggests that wh-indefinites in these contexts behave differently from interrogative wh-expressions.

The similarity in structure between *tèe'bag* and *nu'uh* constructions suggests that *tèe'bag* and *nu'uh* are the same type of constituent. Since *nu'uh* is clearly a verb (it may take different aspect markers, as well as subject agreement clitics for pronominal subjects), it may be possible that *tèe'bag* is a predicate, rather than a quantifier. Direct evidence for this, however, is difficult to find: *tèe'bag* does not take aspect or subject agreement markers, so if it is a predicate, it is a morphologically impoverished one. Evidence against the predicate status of *tèe'bag*, however, comes from the fact that *cèi'ty* may also appear interchangeably with *tèe'bag* in negative existential and negative indefinite constructions. These structures are identical to those formed with *tèe'bag*, except for the presence of *cèi'ty*:

116. Cèi'ty tu studya'aann-dya' b-da'uw pap  
neg who student-dya' perf-eat potatoes  
“No student ate potatoes”

If *cèi'ty* is indeed a quantifier (as was argued earlier) it is highly unlikely that a syntactically distinct constituent should be able to replace it freely in otherwise identical structures.<sup>4</sup>

Wh-words are used as indefinite pronouns in a second existential construction as well. In this construction, the wh-words are preceded by the word *dòonn* “whether, if”. The example below shows *do'onn* used with its

<sup>4</sup> Munro (class lectures), however, suggests that the fact that *cèi'ty* may appear with pronominal subject agreement markers in sentences with negated Irrealis verbs suggests the possible verbal/predicational status of *cèi'ty*. She also points to other languages in which negation is realized by verbal forms. (A different account for the cooccurrence of *cèi'ty* and subject agreement markers, which assumes the quantificational status of *cèi'ty*, is proposed in Lee 1996 (summarized in the preceding chapter)).



independent meaning of “whether/if” (in which it introduces an indirect question); the examples that follow show its use with *wh*-indefinites:

117. R-càaz-zy-a’ g-ahcbi-a’ do’onn a r-zehny  
 hab-want-just-1s irr-know-1s if already hab- arrive  
 “I just want to know if

e-mail rèe’ lòo’  
 e-mail this to.you  
 this e-mail gets to you”  
 (ML, entry for *do’onn*)

118. Ngaista’ do’onn cali ch-o’-nn nah zhih  
 in.a.while if where irr-go-1p now day  
 “Later today, we’ll go somewhere (we don’t know where)”  
 (ML, entry for *do’onn*)

119. Do’onn x:a mo’od g-uny-ih  
 if what way irr-do-3s.prx  
 “I’ll do it somehow (I don’t know how)” (ML, entry for *do’onn*)

The *do’onn-wh* construction differs from the *nu’uh-wh* construction in that it does not allow more than one *wh*-indefinite to follow it directly:

120. Tòò’oh ch-i-gwì -ënn dònnon tu g-uuny gaan  
 let’s.go irr-go-see-1p if who irr-do win  
 “Let’s go see who wins”

121. \*Tòò’oh ch-i-gwì -ënn dònnon tu xi g-uuny gaan  
 let’s.go irr-go-see-1p if who what irr-do win  
 “Let’s go see who wins what”

Both the *do’onn* and *nu’uh* indefinite formation constructions, however, express only non-specific (narrow-scope) indefinites. As the examples above show, *do’onn-wh* can only denote still-unidentified entities. A similar (but less marked) distinction holds for *nu’uh* indefinites, as seen in the contrast below:

122. A teihby nih r-umbèe Gyeeihlly z-uu jwer  
 top one rel hab-know Mike def-stand outside  
 “Someone that Mike knows is outside”

123. N-u’uh tu nih r-umbèe Gyeeihlly z-uu jwer  
 neut-exist who rel hab-know Mike def-stand outside  
 “Someone that Mike knows is outside”

Garcia notes a difference in speaker presupposition between (122) with *teihby*, and (123) with *nu'uh tù*. The *teihby* example would be used if, for instance, only one person were at the door and the speaker knew that Mike knew this person. The sentence with *nu'uh tu* would be used if there were more than one person at the door, and the speaker had reason to believe that Mike knows one of these people, but had no idea which of these people it would be. In short, *teihby* can be used to refer to specific indefinites, while *nu'uh* -wh refers to non-specific indefinites.

SLQZ wh-words may also be used non-interrogatively (that is, in contexts other than direct or indirect wh-questions) in a number of other, non-existential constructions.

*Xi* “what”, for instance, may be used to introduce exclamatives:

124. *Xi tuxhmaan!*  
 what week  
 “What a week!” (ML, entry for *xi*)

*Xi* also appears as part of the lexical expression *xi zhě'b* “how much” used in exclamatives of degree. (Note that *zhě'b* by itself can also be used to mean “how much”; the semantic redundancy present in the gloss of the following example, compounded by the presence of *zyè iny* “a lot”, shows that the expression *xi zhě'b* has probably become lexicalized:

125. *Xi zhě'b zyèiny r-a'uhw-u'*  
 what how.much a.lot hab-eat 2s  
 “How much you eat!” (ML, entry for *xi zhě'b*)

*Xi* also appears in a number of other lexicalized expressions denoting degrees or periods of time:

126. *Xi wyahc s-aa zhi'ny-a'*  
 what time def-walk child-1s  
 “It will be a long time until my child walks”  
 (ML, entry for *xi wyahc* )
127. *Xi laa zhih*  
 what name day  
 “a long time ago”  
 (ML, entry for *xi laa zhih*)

Temporal expressions with *xi* seem to denote markedly long periods of time.

A possibility that I will consider is that these expressions are derived from exclamatives such as “(what a) long time”, etc. This analysis is consistent with both the syntactic parallel between these expressions and true exclamative uses of *xi* “what” such as (124), and with the observation that exclamatives introduced by wh-words can only be predicated on qualities

that can be measured on a gradable scale, such as size and time (Cresswell 1973, cited in Gutiérrez Rexach 1996):

128. How tall he is!

129. What a long time this is taking!

These expressions also differ from other *wh*-indefinite expressions in that the *wh*-expression is clause-initial, as it is generally in *wh*-questions: in *tèe'bag* and existential constructions, the *wh*-word appears to get its non-interrogative, indefinite reading by being preceded by a negative or existential term. In short, the indefinite interpretation of *wh*-words in SLQZ appears to be syntactically determined. Syntactic and semantic motivation for this constraint will be examined in the next section.

### ***The Use of Wh-Indefinites in Other Languages***

*Wh*-words appear with indefinite, rather than interrogative, uses in a number of languages unrelated to SLQZ (such as Chinese (Cheng 1992, Li 1991), Hungarian (Cheng 1992), Tzotzil (Aissen 1992), Dutch (H. Koopman, p.c.), and Western Apache (Potter 1997)). In these languages, as in SLQZ, the indefinite use of *wh*-words is limited to certain syntactic contexts. Below, I will give brief synopses of the salient features of *wh*-indefinite constructions in Chinese (the most widely documented of the languages with *wh*-indefinites) and Western Apache (whose *wh*-indefinite constructions share important semantic features with those in SLQZ).

In Chinese, *wh*-words may be interpreted as indefinite pronouns in negative constructions (130), yes/no questions (131), conditional clauses (132), and in complements of non-factive verbs (133):

130. Ta bu xihuan shenme  
 he not like what  
 "He doesn't like anything"  
 (Li 1992, p. 127)

131. Ta xihuan shenme ma?  
 he like what Q  
 "Does he like something/anything?"  
 (Li 1992, p. 128)

132. Yaoshi/Ruguo ta xihuan shenme...  
 if he like what  
 "If he likes anything..."  
 (Li 1992, p. 128)

133. Wo yiwei/renwei/cai/xiwang ni xihuan shenme (dongxi)  
 I think/think/guess/hope you like what (thing)  
 “I think/think/guess/hope you like something”  
 (Li 1992, p. 128)

These contexts have been posited as “affective contexts” (Cheng 1991, p. 112), and “contexts in which the truth value of the proposition is not fixed in a definite manner” (Li 1992, p. 134).

Li supports this definition by pointing out that *wh*-words receive may also receive indefinite readings in the presence of adverbs expressing speaker uncertainty (such as “probably”) and grammatical particles expressing a speaker’s lack of direct experience of an event he/she is asserting to be true.

Furthermore, the availability of indefinite readings for *wh*-expressions is syntactically, as well as semantically, constrained in Chinese: in negated sentences, for instance, *wh*-words can only be interpreted as indefinites if *c*-commanded by negation. Thus, object, but not subject, *wh*-words may be interpreted as indefinites in negative contexts:

134. Ta bu xihuan shenme  
 he not like what  
 “He doesn’t like anything” (Li 1992, p. 135)
135. Shenme ren bu xihuan ta?  
 what man not like he  
 “Who does not like him?”  
 “Someone does not like him” (Li 1992, p. 135)

Li thus treats *wh*-indefinites as variables that require *c*-command by a local binder. This seems to parallel their usage in SLQZ.

Western Apache, an Athabaskan language, likewise uses *wh*-words as indefinites in certain semantic and syntactic contexts. One salient context in which *wh*-words receive indefinite, rather than interrogative, readings is when they directly precede the marker *shi*. (Compare (136) and (137)). *Shi* can also be used as a modal particle that modifies entire clauses (138):

136. Hadín kih náágole’?  
 who house 3sg.imprf.build  
 “Who is building a house?”  
 (Potter 1997, p. 94)
137. Hadínshi kih náágole’?  
 who.UNCERT house 3sg.imprf.build  
 “Someone is building a house”  
 (Potter 1997, p. 94)

138. Nailín magashi naízyood shi  
 girl cattle 3sg.perf.herd might  
 “The girl might have finished herding the cattle”  
 (Potter 1997, p. 93)

Potter analyses *shi* as a head that takes either clauses or wh-indefinites as complements: these complements then raise to the specifier of the projection in which *shi* is generated, thus accounting for the fact that *shi* directly follows the constituents it modifies.

Potter draws a semantic parallel between the modal and indefinite-forming uses of *shi*: in its modal use, *shi* serves to express speaker uncertainty about the truth of an event (such as whether the cattle have been herded in (138)). When used as indefinites, wh-words in Western Apache assert the existence of something without committing the speaker to knowing the exact identity of this element. Thus, *shi* serves to express a tentative level of speaker assertion of an event in both contexts. In the following section, I will outline an application of this idea to SLQZ.

#### 4.5.5 The Syntax of WH-Indefinites in SLQZ

The previous section showed that wh-indefinites in SLQZ may appear in the following contexts: in *tèe’bag* negation constructions, in narrow-scope indefinite constructions, and in exclamative constructions and lexicalized expressions potentially derived from exclamatives.

These contexts share a common semantic feature: like wh-indefinite constructions in Chinese, they represent propositions with reversed or un-fixed truth values. That negation reverses the truth value of a proposition is obvious. Exclamatives, as noted often in the literature (Lewis 1972, cited in Gutiérrez Rexach 1996) are distinguished by the fact that they do not have inherent truth values of their own (there is no way, for instance, that an exclamative such as “What a week!” can be posited to have an absolute truth value).

The use of wh-indefinites in existential constructions appears at first glance to be a counterexample to this, but the fact that only non-specific indefinites may be expressed in constructions with wh-indefinites supports the idea that the speaker is expressing uncertainty about the identity of a participant in the event being described. The weak level of speaker certainty in these contexts seems to parallel the “tentative assertion” expressed by wh-words in the specifier of a modal marker in Western Apache.

This raises the issue of how this translates into a syntactic structure. The existential and *tèe’bag* structures suggest that SLQZ, like Chinese, requires wh-indefinites to be c-commanded by an operator. Furthermore, wh-words in affective contexts such as conditional clauses and yes/no questions only receive indefinite readings when preceded by *nu’uh*. This supports Cheng’s (1991) idea that wh-indefinites are necessarily bound by

existential closure, and suggests that *nu'uh/tè'bag* is responsible for providing existential closure over wh-indefinites in these contexts:

139. Y-nni-ùu' nàa' bàll n-u'uh cali y ch-ia' Gyeeihlly  
 irr-tell-2s 1s if neut-exist where irr-go Mike  
 “Tell me if Mike goes anywhere”
140. N-u'uh tu ca-ya'uw ee?  
 neut-exist who prog-eat Q  
 “Is anyone eating?”

Thus, in SLQZ the mere appearance in an affective context is not enough to license the indefinite reading of wh-words: they must also be syntactically dominated (c-commanded) by a semantically appropriate licenser, such as *tè'bag* or *nu'uh*.

#### 4.5.6 The Syntax of *Tè'bag* Negation

In the previous section, I showed that the wh-words in *tè'bag* negation constructions are indefinite pronouns that need to be syntactically (and semantically) licensed by *tè'bag*. In the following sections, I will present explicit syntactic analyses of negative indefinite and existential negation constructions. First, I will address the position of *tè'bag* itself, then turn to the negative indefinite and existential negation constructions themselves.

##### **Where is *Tè'bag*?**

*Tè'bag* shares many distributional features with *a'ti'*. For one, *tè'bag* negation, like *a'ti'* negation, may appear in wh-questions (141) but not with focus-fronted constituents (142):

141. Tu tè'bag xi li'ebr-dya' ny-ùall  
 who no what book-dya' subj-read  
 “Who didn't read any book?”
142. Gye'eihlly tè'bag xi ny-a'uhw-dya'  
 Mike no what subj-eat-dya'  
 “Mike didn't eat anything/\*MIKE didn't eat anything”

Fronted arguments can only be interpreted as answers to wh-questions, not as contrastively focused. The following can only be used as an answer to the question “Who didn't eat anything?”.

This suggests that like *a'ti'*, *tè'bag* generally surfaces in FocP. However, like *a'ti'*, *tè'bag* may also appear at the left edge inside relative clauses:

143. Studya'aann nih tèe'bag tu mee's-dya'r-yu'làà'z n-u'uh rèè'  
 student that no who teacher-dya' hab-like neut-exist here  
 "The student who no teacher likes/who likes no teachers is here"

As shown in section 4.4.4, this is a position in which focused constituents are normally blocked. This was used as evidence that *a'ti'* surfaces in PredP, a position above TP, but below FocP in relative clauses. I thus assume that *tèe'bag* does as well.

Another parallel between *a'ti'* negation and *tèe'bag* negation is that there are no GDCF effects in *tèe'bag* constructions: *-dya'* is obligatory even when preverbal constituents such as wh-words appear:

144. \*Tu tèe'bag xi li'ebr ny-ùall  
 who no what book subj-read  
 "Who didn't read any book?"

This suggests that like *a'ti'*, *tèe'bag* obligatorily surfaces in a position above NegP.

Like *a'ti'* negation, *tèe'bag* negation also shows no Irrealis Negation effects: Irrealis verbs under *tèe'bag* negation receive standard future readings, rather than imperative or subjunctive-like readings:

145. Tèe'bag xi g-a'uh-dya' Gye'eihlly  
 no what irr-eat-dya' Mike  
 "Mike won't eat anything"

This indicates that verbs negated by *tèe'bag*, like those negated by *a'ti'*, move through NegP2 rather than NegP1: since they do not change modal features under negation, they do not pass through MoodP as do verbs that undergo clausal negation with *cè'ity*. This in turn indicates that the negative features of *tèe'bag* (and the constituents it negates) must be checked below MoodP. Thus, *tèe'bag* negation, like *a'ti'* negation, is licensed by movement through the lower negative projection, NegP2.

### **The Syntax of Negative Indefinites**

The negative indefinite construction is composed of the *tèe'bag*-wh complex followed by the verb, then the particle *-dya'*. Below is an example repeated from above:

146. Tèe'bag tu b-da'uh-dya' gueht  
 no who perf-eat-dya' tortilla  
 "No one ate tortillas"

From the previous sections, it should be clear that the underlying structure for this construction must meet several criteria: first, wh-indefinites must precede the verb and surface directly after *tèe'bag*; second, *tèe'bag*

must raise at least as high as PredP; third, negation must be licensed in the lower negative projection, NegP2; and finally, both the wh-indefinites and the verb must appear under the scope of *-dya'*.

I will thus assume the following derivation for negative indefinites.

As previously mentioned, *tèe'bag* is problematic in that it patterns with *nu'uh* ‘‘exist’’, a verbal predicate, in how it forms sentences with wh-indefinites, yet it lacks verbal morphology and behaves like a quantificational determiner. For instance, it can be used as a stand-alone negative answer to a question:

147. Q: Tu r-indyalàà'z-u'?  
 who hab-believe-2s.inf  
 ‘‘Who do you believe?’’

A: Tèebag  
 Nobody

If it is a determiner, however, then it is puzzling how it can take scope over more than one wh-indefinite – each originating as an independent argument – simultaneously.

These facts can be reconciled as follows: *tèe'bag*, like *cèi'ty*, is a quantifier that selects a VP complement. However, while *cèi'ty* can take any VP as its complement, *tèe'bag* allows only one verbal complement: a covert existential verb that is essentially a silent version of *nu'uh*. This covert existential verb, in turn, takes as its complement the overt VP and its arguments (irrelevant projections omitted below):<sup>5</sup>

148.

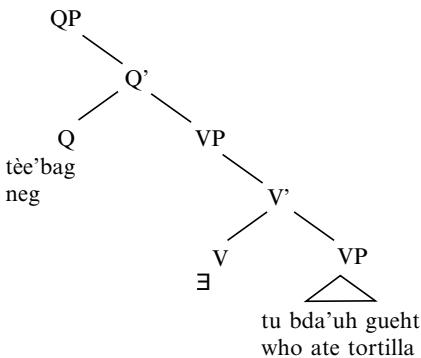

A consequence of this is that *tèe'bag* itself cannot be posited to have its own existential force: this must come from the covert existential predicate it takes as its complement. Rather, *tèe'bag* itself encodes only negation.

<sup>5</sup> The presence of a covert existential predicate under clausal negation in future Irrealis constructions was also argued for in Chapter 3.



Thus, the clausal negation marker *cě'ity*, which also subcategorizes VP complements, may appear interchangeably with *tèe'bag* in negative existential constructions. This also accounts for why *tèe'bag* constructions so closely resemble existential constructions: they contain a covert existential structure.

Further evidence for the presence of a covert existential predicate comes from the following utterance recorded in San Lucas Quiaviní. Here, a related negative word *tèeru'* “no more” appears in a negative existential construction with no visible verb: instead, *tèeru'* is followed by a wh-indefinite pronoun then *-di'*:<sup>6</sup>

149. *Tèeru xi di èee?*  
 no.more what dya' Q  
 “There isn't anything else?”

This structure appears to be parallel to the future Irrealis negation constructions discussed earlier in this chapter.

I assume the structure in (148) is monoclausal: a single set of inflectional projections dominates both the covert existential VP and its lexical VP complement. In short, the covert existential simply forms an additional VP shell as part of the main predicate.

The wh-indefinite subject above is generated as a normal argument of the lexical VP, in the specifier of VP<sub>caus</sub>. (Wh-indefinite objects are likewise generated like normal object DPs.) It then raises to adjoin to spec VP (VP<sub>asp</sub>, which contains an spatiotemporal event argument in its specifier (this point will be discussed in the next chapter)). This marks the wh-indefinite as a variable identified with the event denoted by the verb.

In constructions with more than one wh-indefinite, the lower one adjoins to spec, VP<sub>asp</sub>, then the higher wh-indefinite adjoins to the lower one. For instance, in (150) *xi* “what” adjoins to *bda'uw* “ate” then *tu* “who” to *xi*.

150. *Tèe'bag tu xi b-da'uw-dya'*  
 neg who what perf-eat-dya'  
 “Nobody ate anything”

<sup>6</sup> *Tèe'bag* itself is potentially bimorphemic: *-bag* is a common clitic used to express emphasis. I will assume, however, that *tèe'bag* is treated as a single lexical item.

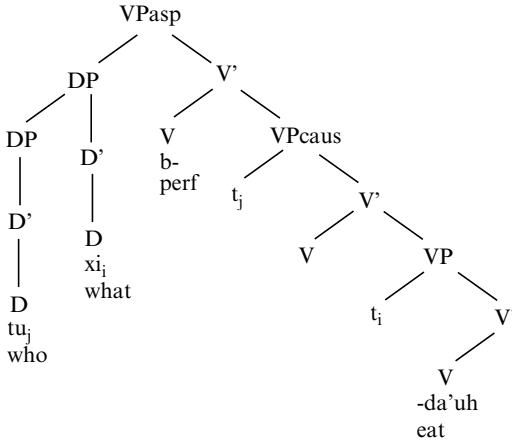

However, the head of  $VP_{asp}$  is already occupied by the Perfective aspect marker *b-*. Thus, the *wh*-indefinite (or indefinites) cannot remain in spec,  $VP_{asp}$  without incurring a GDCF violation; it must subsequently move elsewhere. I will return to this point momentarily.

In the preceding example, then, the *wh*-indefinite *tu* is generated VP-internally as the subject of “eat”:

151. Tè'bag tu b-da'uh-dya' gueht  
 no who perf-eat-dya' tortilla  
 “No one ate tortillas”

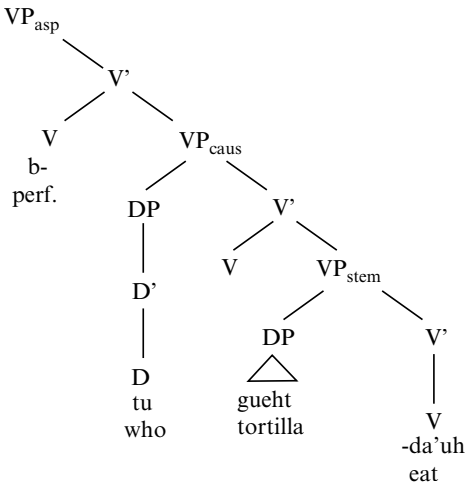

From this base configuration, the  $DP$  object (“tortillas”) raises out to spec, AgrOP, as usual, and *tu* raises to the specifier of  $VP_{asp}$ :

152.

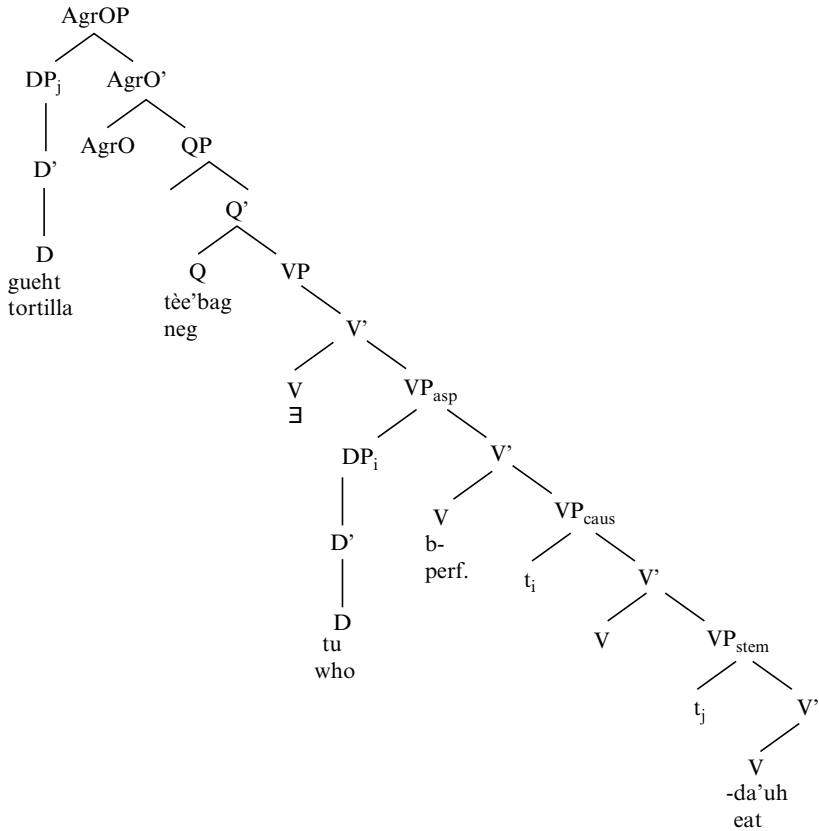

However, *tu* “who” is in an illegal configuration: as previously noted, it appears in the specifier of the highest VP shell,  $VP_{asp}$ , which already contains an overt head (the Perfective aspect marker *b-*), in violation of the GDCF. In order to surface in a legal configuration, *tu* must raise out of VP. I assume that it raises into the specifier VP of the covert existential verb. In constructions where more than one wh-indefinite appears, the adjoined wh-indefinite DPs likewise raise together into this position.

Next, the entire QP, including its lexical verbal complement, raises through TP into the specifier of NegP2. (Projections not directly involved in this movement have been omitted for clarity):

153.

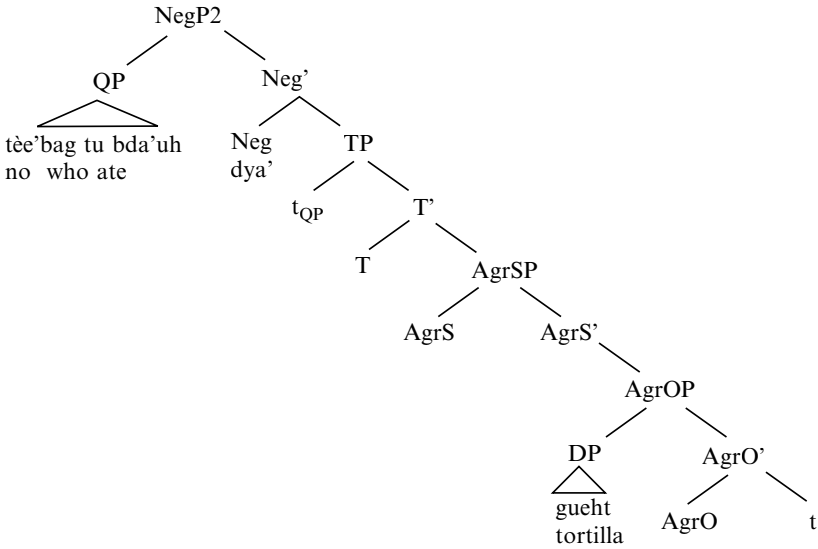

This movement checks the tense features of the lexical verb (I assume the covert existential shares these tense features) as well as the negative features of *tèe'bag*.)

As previously argued, *tèe'bag* appears to surface in PredP (in relative clauses) or FocP (in other contexts). This suggests that the QP headed by *tèe'bag*, like those headed by *a'ti'*, raises out of NegP into PredP (where it stays in relative clauses), then to FocP (where it surfaces in other contexts). As in the cases of negated nonverbal predicates with *a'ti'*, this movement is not driven by focus features on the negated constituent (since negated indefinites do not receive a focused reading), but by economy and the need to satisfy the Focus Criterion.

### **Negative Existentials**

The negative existential construction differs from the negative indefinite construction in that *-dya'* appears after a negated nominal, rather than after the verb. As noted in Section 4.3, this reflects a difference in the scope of negation between the two constructions: in negative existential constructions, negation takes scope over the restrictor of the existential quantification, rather than over the nuclear scope). This construction is superficially parallel to non-verbal *a'ti'* negation:

154. Tèe'bag tu studya'aann-dya' b-da'uw pap  
 no who student-dya' perf-eat potatoes  
 "No student ate potatoes"

Here, there are a number of parallels with *a'ti'* negation of nonverbal constituents: *-dya'* surfaces above the verb, suggesting that it is base-generated in a surface position above TP. For instance, compare (154) with (155):

155. A'ti' me's-dya' n-àa Gye'eihlly  
 neg teacher-dya' neut-be Mike  
 "Mike is not a teacher"

Also like the *a'ti'* negation construction, as previously noted, there are no doubly-filled comp effects with negative existential constructions: *-dya'* is obligatory, even when other material precedes *tèe'bag*. This can be seen in (156) and (157):

156. Tu tèe'bag xi li'ebr-dya' ny-ùall?  
 who no what book-dya' subj-read  
 "Who didn't read any book?"
157. Tu a'ti' me's -dya' n-àa?  
 who neg teacher-dya' neut-be  
 "Who isn't a teacher?"

These data suggest that the derivation of non-verbal *a'ti'* negation and negative existential constructions are identical. However, I will show that they differ in a few significant ways.

I assume that, as in the negative indefinite construction, *tèe'bag* is a quantifier that takes as its complement a covert existential predicate, which in turn takes a lexical VP and its arguments as its complement. The wh-indefinite takes the negated lexical NP as its complement. Thus, (154) will originate as the structure in (158):

158. Tèe'bag tu studya'aann-dya' b-da'uw pap  
 no who student-dya' perf-eat potatoes  
 "No student ate potatoes"

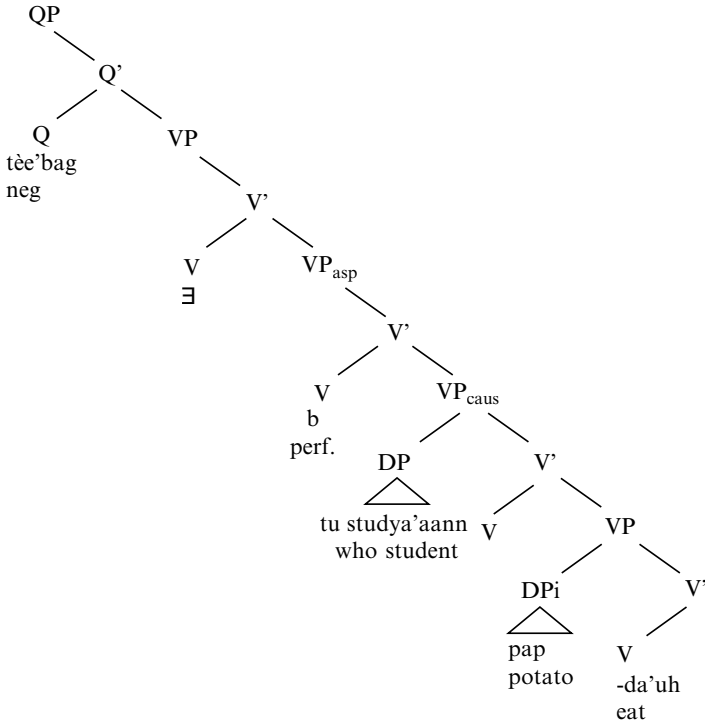

This structure, like the negative existential structure, is monoclausal.

Any non-negated arguments in these structures raise to their respective agreement projections:

159.

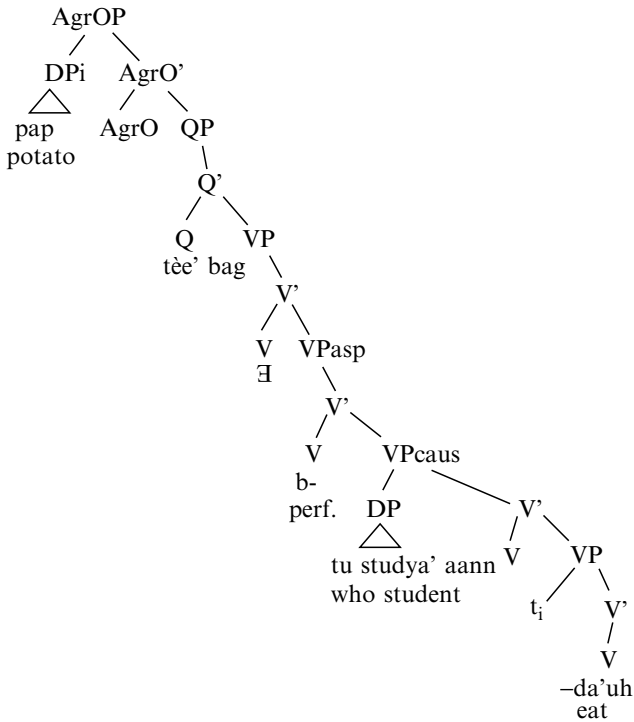

The *wh*-indefinite and its lexical complement likewise raise out of the lexical VP. Here, however, there is a slight difference from the negative indefinite construction: the *tée' bag* complex does not raise through VP<sub>asp</sub>. This movement is needed for semantic reasons in negative indefinite constructions (it marks the *wh*-indefinite as a variable associated with the event denoted by the VP). However, in negative existential constructions, the negated constituent moves into NegP2 independently of the VP in which it is generated, and negation takes scope only over the DP/NP argument, rather than over the event. Thus, it raises directly into the specifier of the covert existential VP:

160.

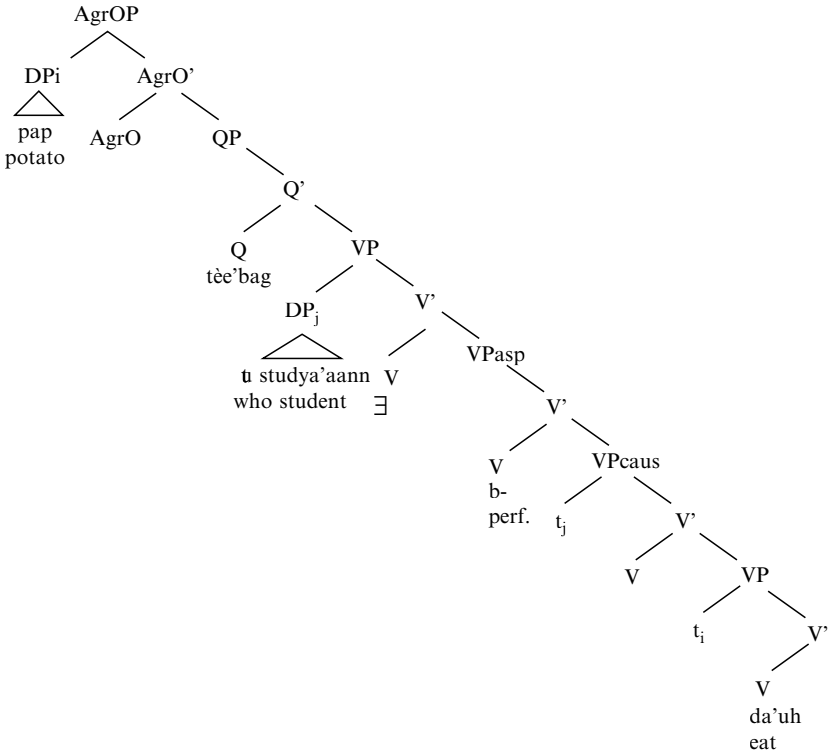

VP<sub>asp</sub>, which has tense features that need to be checked, raises into TP, leaving *tèt'bag*, the negated argument, and the covert existential VP behind. This movement also reflects the fact that the lexical VP and the event it represents are not themselves under the scope of negation, and thus does not undergo movement to NegP along with *tèt'bag*:



161.

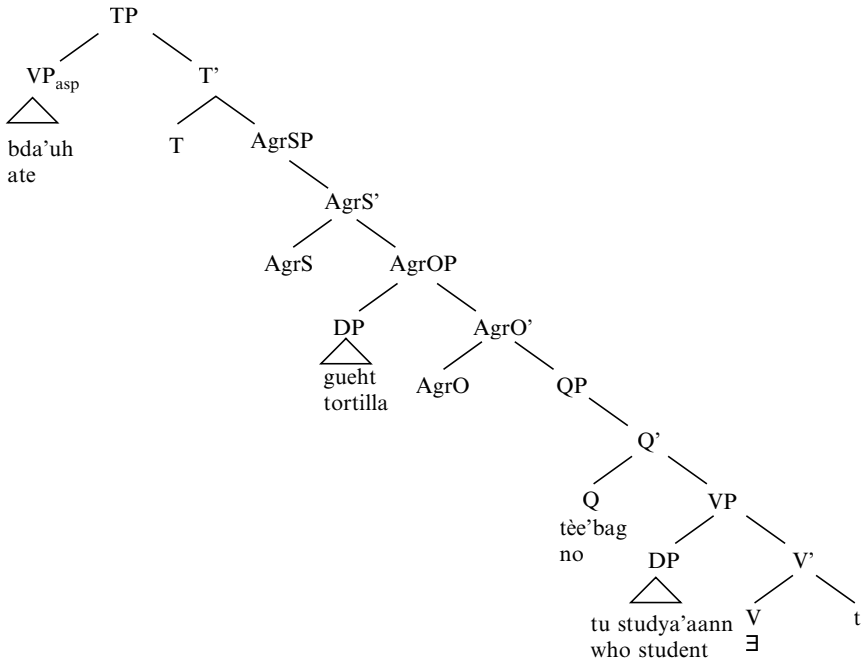

The *tée'bag* complex then raises into spec, NegP2:

162.

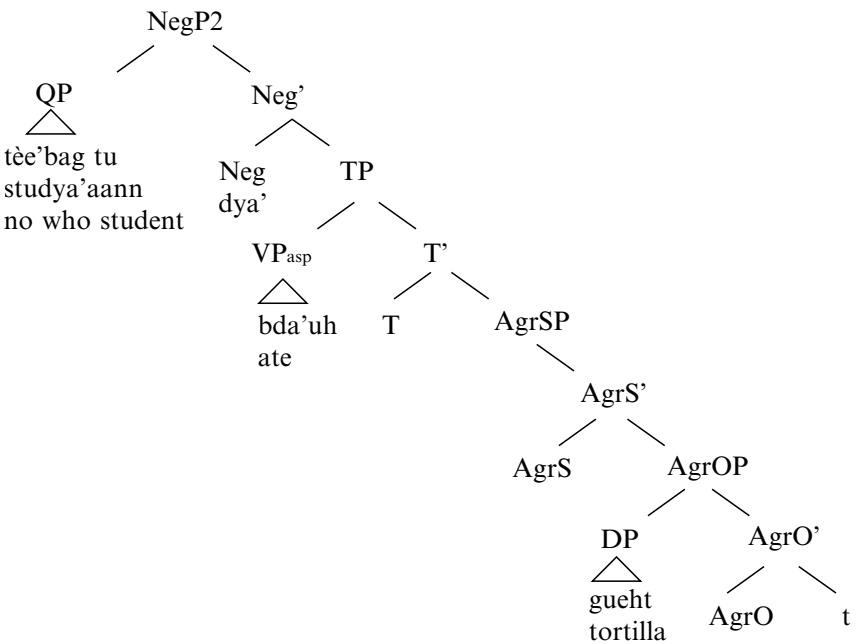

The QP then raises out of NegP2 to FocP to satisfy the Focus Criterion and avoid a GDCF violation. (In relative clauses, this movement will target PredP rather than FocP; PredP is omitted from the tree below for clarity):

163.

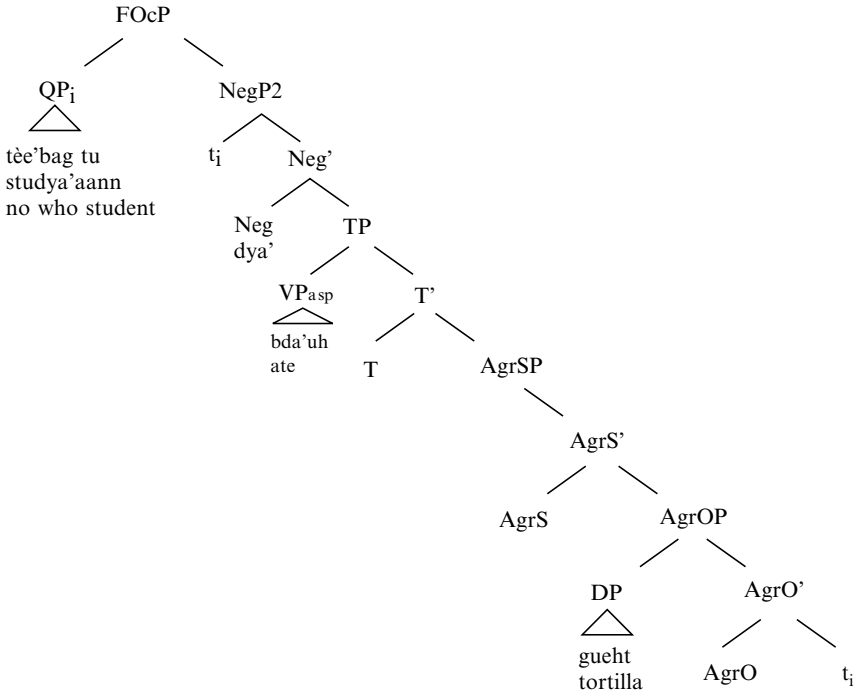

## 4.6 Summary

This chapter outlined the syntax and semantics of three of the most common negation constructions in SLQZ: clausal negation with the negative marker *cè'ity*, constituent negation with the negative marker *a'ti'*, and indefinite/existential negation with the negative marker *tèe'bag*. I showed that these superficially similar constructions, upon close examination, show a number of structural differences. These differences reveal the existence of a number of distinct, interacting preverbal functional projections: FocP, PredP, two negative phrases, and two topic positions, which are ordered in the following hierarchy:

164.

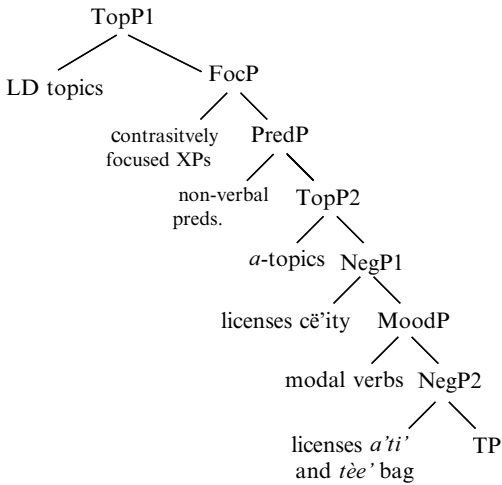

I also showed that the co-occurrence restrictions between several of these projections, as well as the relative rarity of structures with more than one preverbal constituent, can be attributed to the Focus Criterion: the Focus projection must be overtly filled in all SLQZ sentences. When no contrastively focused constituent is present, then either the entire sentence or the highest preverbal constituent is required to raise into FocP.

## 5 More on the Structure of the Left Periphery: The Syntax of Questions

### 5.1 Overview

The negation constructions described in the previous chapter revealed additional information about the contents and ordering of preverbal functional projections. In Chapter 4, it was shown that FocP is distinct from the preverbal projection in which nonverbal predicates are licensed, PredP, and that two separate preverbal projections, TopP1 and TopP2, exist for topics.

Wh- and yes/no questions, constructions that both involve the left periphery, reveal evidence for an additional preverbal projection: IntP, a projection directly above FocP in which interrogative elements – wh-words and yes/no question markers – are licensed. This chapter will discuss the syntax and semantics of wh-questions, then the syntax and semantics of yes/no questions.

### 5.2 Wh- and Focus Are Not the Same Projection

In the previous chapter, the interaction of wh-movement and negation proved to be a useful diagnostic for the syntactic positions of the three negation markers. In addition, the interaction of *a'ti'* negation with wh-questions reveals that syntactic focus movement and wh-movement processes widely believed to involve the same projection and same movement across a range of languages (Rizzi 1995 (Italian); Horvath 1986, Kiss 1988, 1994 and Kenesei 1993 (Hungarian); Ouhalla 1997 (Standard Arabic)) – are syntactically distinct operations: as shown in the previous chapter, *a'ti'* negation may occur in wh-questions, but not with focus-fronting of other other constituents. I show in this chapter that wh- and focus movement are different operations involving two separate, but interacting, projections: FocP and IntP.

At first glance, SLQZ appears to pattern with other languages with focus movement in this regard. Both target immediately preverbal positions (1-2) and, in most cases, they may not occur simultaneously (3):

1. Gye'eihlly y-tàa'az Li'eb  
Mike irr-beat Felipe  
"MIKE will beat Felipe/Felipe will beat MIKE"
2. Tu y-tàa'az Li'eb?  
who irr-beat Felipe  
"Who will Felipe beat/Who will beat Felipe?"
3. \*Tu Gye'eihlly y-tàa'az?  
who Mike irr-beat  
"Who will MIKE beat/ who will beat MIKE?"

Focus fronting also blocks long-distance wh-movement, as seen in (4-5):

4. Xi r-ralloh liu' [g-a'u Gye'eihlly t] ?  
what hab-think-2s.inf irr-eat Mike  
"What do you think Mike will eat?"
5. \*Xi r-ralloh liu' [Gye'eihlly g-a'u t] ?  
what hab-think-2s.inf Mike irr-eat  
"What do you think MIKE will eat?"

It also affects the range of interpretations of potentially ambiguous wh-words:

6. X:a mo'od r-ralloh liu' [y-zëhny Gye'eihlly]?  
what way hab-think-2s.inf irr-arrive Mike  
"How do you think Mike will arrive?"  
["By what form of transportation do you think Mike will arrive?"/  
"What makes you think Mike will arrive?"]

These two possible readings correspond to two possible base-generated positions for the wh-phrase "how". It may either originate inside the embedded clause (giving the "what form of transportation" reading), or it may originate inside the matrix clause (giving the "What makes you think" reading).

When the subject of the embedded clause is focus-fronted, however, this ambiguity disappears:

7. X:a mo'od r-ralloh liu' [Gye'eihlly y-zëhny ]?  
 what way hab-think 2s.inf Mike irr-arrive  
 "How do you think MIKE will arrive?"  
 [\* "By what form of transportation do you think Mike will arrive?"]  
 ["What makes you think Mike will arrive?"]

In this case, the only available interpretation is that in which the wh-phrase "how" is base-generated in the matrix clause, above the focused embedded clause subject.

If wh-movement and focus movement target the same position, as argued, then the ungrammaticality of (3) and (5), as well as the interpretive contrasts between (6) and (7) can be easily attributed to bounding violations: wh-movement cannot occur past a filled wh-licensing position. Patterns such as these, attested crosslinguistically, support the view that wh- and focus movement target the same position.

The situation, however, is a bit more complex in SLQZ. There are a number of syntactic contexts in SLQZ in which wh-movement is allowed, but focus movement is not. *A'ti'* negation is such as case: while *a'ti'* negation structures disallow focus-fronted constituents, wh-fronting is allowed. This is seen in the following examples:

8. \*Gye'eihlly a'ti' studya'aann-dya' n-àa  
 Mike neg student-dya' neut-be  
 "MIKE isn't a student"
9. Tu a'ti' studya'aann-dya' n-àa?  
 who neg student-dya' neut-be  
 "Who isn't a student?"

An additional piece of evidence for separate landing positions for wh- and focus movement comes from the distribution of preverbal constituents in sentences whose verbs are marked with the Definite aspect. The Definite aspect, as noted in Chapter 1, is primarily used to express future events that the speaker feels sure will occur: thus, future events expressed with the Definite aspect have more emphatic assertive force than those expressed with the Irrealis aspect, the other aspect used to express future events:

10. Y-tòò'oh Gye'eihlly ca'rr  
irr-sell Mike car  
“Mike will sell the car”
11. S-tòò'oh Gye'eihlly ca'rr  
def-sell Mike car  
“Mike will definitely sell the car”

Future sentences with Definite-marked verbs also disallow preverbal (focused) arguments:

12. \*Gye'eihlly s-tòò'oh ca'rr  
Mike def-sell car  
“MIKE will definitely sell the car”

Wh-words, however, may appear before Definite-marked verbs:

13. Tu s-tòò'oh ca'rr?  
who def-sell car  
“Who will definitely sell the car?”

In Lee 2005, I argued that TPs containing Definite verbs obligatorily raise through MoodP to Focus: the focus readings thus given to Definite-marked TPs contribute to their characteristically strong assertive force. The fact that TP must raise to spec, FocP in sentences with Definite-marked verbs would account for the ban on focused arguments: since FocP is filled, there would be no place for them to land.

If wh-words and focused constituents were licensed in the same position, then the cooccurrence of preverbal wh-words and Definite-marked verbs is unexplainable: assuming that Definite-marked TPs surface in FocP themselves, then there should be no possible landing spot for fronted wh-words. Thus, the only option is to posit separate positions for focused constituents and wh-words.

### 5.2.1 The Interaction of Focus and Wh: Reasons for Co-occurrence Restrictions

I will thus assume that wh-features and focus features are indeed licensed in separate projections. If wh-words and focus surface in different positions, however, any operations involved in wh-movement must be able to account for both the co-occurrence restrictions between wh-movement and

focus-fronting (described in the previous chapter), as well as the lack of these restrictions in focus negation contexts.

The possibility that I will propose is that *wh*-questions have both [+Q] features and [+foc] features: that is, *wh*-expressions must pass through both FocP and an interrogative position (IntP) in order to have their features checked (irrelevant projections are omitted in the tree below):

14.

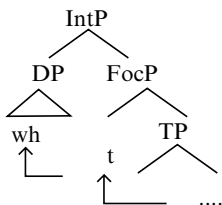

If FocP is filled, then *wh*-expressions may not appear, since there is no longer any way for them to have their focus features checked:

15.

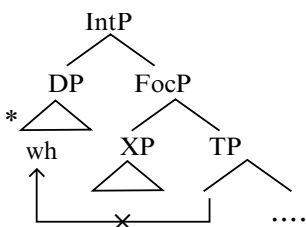

Conversely, if *wh*-expressions (apart from “why” and wide-scope “how”) appear, they must pass through FocP themselves. Since spec, FocP contains the *wh*-trace, it is unavailable for other constituents. The possibility of focused constituents with “why” and wide-scope “how” results from a difference in semantic function between these elements and other *wh*-expressions.

This possibility is supported by both semantic and crosslinguistic typological considerations. Both types of evidence will be discussed below.

Semantic evidence for the necessity of focus movement in *wh*-questions comes from the overlapping semantic functions of *wh*-expressions and contrastively focused constituents: both serve to single out members of sets that fulfill a particular role. Rooth (1985) defines focus as selecting an individual out of a set of possible candidates that have a particular quality. Likewise, standard *wh*-questions ask listeners to identify an individual



out of a set of candidates that have certain qualities. (Similar semantic parallels between contrastive focus and *wh*- constructions have been noted by Horvath 1986, among others.) The main semantic difference between contrastive focus constructions and *wh*-questions is that the former identify an individual out of the set of candidates, while the latter assume that such an individual exists, and ask listeners to identify it. I will assume that this difference is reflected in the syntax in the following way: when a referential expression (such as a proper name) moves into FocP, the entity denoted by the expression is identified as the unique member of a set of possible candidates having a certain quality. *Wh*-expressions, however, are non-referential. When a *wh*-word raises into focus, it simply serves to assert the existence of an individual within a set of candidates, but does not specifically identify this individual. When the *wh*-word raises out of focus into the *wh*-projection, it is thus interpreted as questioning the identity of the focused element.

Suggestive evidence for two separate, interacting projections for *wh* and focus comes from the typology of *wh*-questions and focus constructions crosslinguistically: languages vary in whether they form *wh*-questions and focus constructions through overt syntactic movement (as SLQZ does) or by leaving *wh*-words and focused constituents in situ. Kenesei (1993) outlines the following typology of movement strategies for *wh*-questions and focus constructions:

|                         | WH-movement | Focus movement |
|-------------------------|-------------|----------------|
| Chinese, Japanese, etc. | -           | -              |
| English, etc.           | +           | -              |
| Hungarian, etc.         | +           | +              |

**Table 1.** Typology of *wh*- and focus movement strategies (from Kenesei 1993, p. 31).

SLQZ clearly falls into the same grouping as languages such as Hungarian. Conspicuously absent from this list, however, are languages with overt focus movement but without overt *wh*-movement:

| WH-movement | Focus movement |
|-------------|----------------|
| ??          | -              |
|             | +              |

**Table 2.** Unattested wh- and focus movement configuration.

It appears, then, that such languages are unattested. If the licensing position for wh-words is distinct from, and above, FocP, this typological gap can be accounted for by reasons of economy: focus-movement can only occur overtly when wh-movement does. This is seen in languages such as English, in which overt wh-movement is required, but focus is realized in situ: overt movement through focus is only required by wh-expressions, which have to move in any case to reach IntP. When wh-features are strong (that is, if they must be checked by overt movement, per Chomsky 1992, 1995), focus features may also be strong; thus both can be satisfied overtly. This is the case in languages such as Hungarian and SLQZ. When wh-features are weak (that is, if their features can be checked without overt movement), focus features are also weak: both are satisfied covertly at LF. This is the case with languages such as Chinese.

The hypothetical language that requires overt focus movement but has wh-in-situ, however, can be ruled out by the proposal that focus is licensed in a projection below the interrogative projection. If it is the case that wh-expressions must check some of their features by movement through Focus, then a language that requires overt focus movement would also require wh-expressions to raise overtly into FocusP (irrelevant projections omitted below):

16.

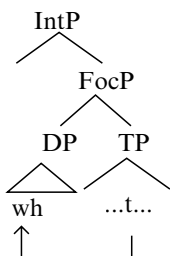

Thus, languages with overt focus movement also force overt movement of wh-expressions, and wh-expressions are thus blocked from appearing in their base-generated positions. If it is indeed the case (as Kenesei's data imply) that no language requires overt movement for expression of focus

but allows *wh*-in-situ, it provides strong suggestive evidence for distinct projections for *wh*-licensing and focus licensing. Positing a single projection (and a single set of semantic and morphological features) for *wh*-words and focused expressions would fail to account for the possible range of *wh*- and focus movement configurations crosslinguistically. Although assuming a single *wh*/focus projection would correctly rule out languages with *wh*-in-situ and overt focus movement (if *wh*-movement and focus movement are the same process, there should not be any differences in their distribution), it would also wrongly rule out languages such as English, with overt *wh*-movement and covert focus movement. Positing separate, interacting projections for *wh*-expressions and focus correctly predicts the possibility of languages such as English, while ruling out the unattested possibility of languages with overt focus movement and only *wh*-in-situ.

### 5.2.2 The Syntax of Wh-Questions in SLQZ

This interaction between FocP and IntP is instantiated in the syntax in the following way: in non-negated *wh*-questions, TP (the domain in which most *wh*-words are generated) raises into focus itself, fulfilling the Focus Criterion and blocking the raising of other constituents into this position (non-relevant projections omitted for clarity):

17.

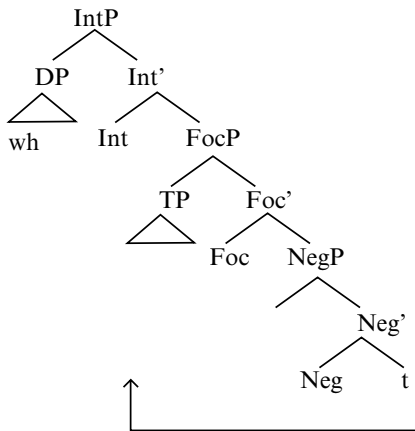

Since the raised TP contains either the base-generated *wh*-word or *wh*-trace (in the case of argument *wh*-questions and VP-modifying adverbial *wh*-questions), movement of the TP into FocP satisfies the need for *wh*-words to have features checked in FocP.

Movement of TP into FocP is independently suggested by Rizzi's (1995) observation that in Italian, an SVO language, focused constituents may be fronted to pre-subject position, but *wh*-expressions may not appear directly before subjects:

18. QUESTO Gianni ti dirà (non quello che pensavi)  
 THIS Gianni to-you will-say (not that which you-thought)  
 "Gianni will say THIS to you" (not what you thought  
 (he would say))
19. \*Che cosa Gianni ti dirà?  
 what thing Gianni to-you will-say  
 "What will Gianni say to you?" (examples from Rizzi 1995, p.16)

Rizzi attributes this asymmetry not to a difference in position between IntP and FocP (which he argues to be a single projection) but to the requirement that *wh*-licensing requires that both the head and specifier of the licensing position (FocP, in his view) be filled. This requirement is motivated by the assumption that, since *wh*-features of matrix clause *wh*-questions are generated inside TP (e.g., by constituents base-generated inside TP), these features must somehow be moved into the projection in which *wh*-features are checked. Thus, when *wh*-movement occurs in a matrix clause, verbs move obligatorily from the head of TP to the head of FocP (by I-C movement, in older terms).

Rizzi's hypothesis accounts for the obligatory subject-auxiliary inversion in object *wh*-questions in English, for example, as well as the ungrammaticality of the Italian construction in (19):

20. What did Mike buy?
21. \*What Mike did buy?

Rizzi's analysis can also be updated to account for the fact that TP, not an inflectional head, raises in *wh*-questions in SLQZ. Specifically, since the TP raises to the specifier of a projection distinct from the *wh*-licensing position, spec-head agreement can no longer be considered the motivating factor for movement. (This is particularly true if the Generalized Doubly Filled Comp Filter is assumed to be operative.) Additionally, we need to (1) motivate TP-raising to FocP and (2) justify *wh*-movement out of the filled specifier of FocP.

Motivation for both TP-raising and *wh*-movement out of TP is provided by both the Focus Criterion and the need for *wh*-expressions to check both

[+Q] and [+foc] features, as previously proposed. Argument wh-expressions (as well as adjunct wh-expressions expressing manner/time) are generated inside TP. Thus, TP-raising to FocP moves the TP (where wh- and focus features are generated) into the domain in which these features can be checked. This is consistent with Rizzi's (1995) analysis, outlined above, for the motivation of I-to-C movement in Italian wh-questions. I will assume that the wh-expression remains inside TP until the TP has raised to FocP, then raises out to IntP.

### 5.2.3 Wh-Questions that Allow Focus: A Case of Wh-in-Situ

The preceding account also explains why *xi ni'ih* "why" and the wide-scope reading of *x:a mo'od* "how" differ from other wh-expressions in allowing focused constituents to appear between them and the verb, as seen in (22) and (23):

22. *Xi ni'ih Gye'eihlly b-tàa'z Li'eb?*  
 what reason Mike perf-beat Felipe  
 "Why did MIKE beat Felipe?"
23. *X:a mo'od Gye'eihlly y-zëinny Ldùu'ah*  
 what way Mike irr-arrive Oaxaca  
 "How can it be that MIKE will arrive in Oaxaca?"

"Why" and "how" (with a wide-scope reading) differ from other wh-words semantically in that they question an entire event, not just its participants or the manner of the action involved. For this reason, they have traditionally been assumed to be generated as adjuncts to the entire clause, rather than generated inside VP. Because *why* and (on certain readings) *how* (crosslinguistically) take scope over the proposition expressed by the entire clause, rather than questioning a part of the proposition, I will argue that they are base-generated in IntP.

Assuming this to be correct, then TP-raising to FocP in *xi ni'ih* and wide-scope *x:a mo'od* questions is not necessary for the licensing of these wh-words: since *xi ni'ih* and *x:a mo'od* are generated outside TP, there are no focus or wh-features inside TP that need to be checked by TP-raising to FocP. Thus, TPs in questions with *xi ni'ih* and *x:a mo'od* do not need to raise to FocP for wh-features to be checked, and FocP can be filled by other constituents. (I will assume, however, that when no focus-fronted constituents appear in *xi ni'ih* and *x:a mo'od* questions, TP does raise into FocP in order to satisfy the Focus Criterion.)

If *xi ni'ih*, “why” and wide-scope *x:a mo'od*, “how” are generated in Spec, IntP, this would mean that they do not pass through FocP, and thus differ from other wh-words in that they do not have focus features that need to be checked. Motivation for this possibility comes from the fact that “why” and “how” differ semantically from other wh-words in that they question manners, reasons, and amounts, rather than individuals. Szabolcsi and Zwarts (1993) argue that while possible answers to wh-questions with “what” and “who” are members of unordered sets of individuals, possible answers to questions with “how” and “why” are members of ordered sets.

Szabolcsi and Zwarts show that this difference is realized in natural language by the contrast in possible felicitous answers to questions with *what/who* and *how*. First, consider a simple question with “what”:

24. What did everyone read?

If the person answering the question knew that there were three people in the contextually relevant group “everyone”, and also knew that each of them read three books, he or she could answer the question one of two ways, depending on whether “everyone” is interpreted as scoping over “what”. If “everyone” takes wide scope (“for every person, what did he/she read?”) the question can be answered with a list of every book that every person read (that is, nine books). If “what” takes wide scope (“what thing is such that everyone read it?”) then the question must be answered with only the name of the book or books that were on everyone’s reading list. In short, to correctly answer the question on this second reading, the speaker must compute the intersection of the reading lists of all three people, then pick out and identify the individual item or items in this intersection.

This can be contrasted with the possible answers to a question with “how”:

25. How did everyone behave?

Szabolcsi and Zwarts present the following context for this question: the listener answering the question knows that Bill behaved rudely and stupidly, Mary behaved loudly and stupidly, and John behaved nicely and stupidly. In this case, in contrast to (24) above, they argue that the only felicitous answer to the question is the sum of everyone’s behavior: the speaker cannot answer the question simply by saying “Stupidly”. In short, manners form collective groups that cannot be broken up by the formation of intersections, as can groups of individuals.

In short, allowable “how” and “why” questions differ from other wh-questions in that they do not ask the listener to pick out an individual member of a presupposed set, but to identify a collective group of behaviors.

This difference can be directly linked to the different roles Focus plays in the formation of “how” and “why” questions and other wh-questions in SLQZ. Recall that constituents raised into FocP are identified as uniquely selected members of sets of possible candidates. Thus, focused constituents are individuals that can be picked out of groups. If Szabolcsi and Zwarts are correct, then manners and reasons (among other things that “how” and “why” normally represent) cannot be individual members of sets, and thus cannot be identified as such by being moved into FocP. Thus, there is no motivation for “how” and “why” to raise through FocP in SLQZ.

#### 5.2.4 Another Possible Account

In the preceding sections, I have argued that wh-words and focused-fronted words occupy separate, but interacting projections in SLQZ. This proposal was motivated by the existence of syntactic constructions (*a'ti'* negation and future sentences with Definite-marked verbs) in which focus movement is blocked, but wh-movement is allowed. These constructions suggested that wh-words occupy a distinct projection above FocP. The apparent cooccurrence restrictions between focused elements and wh-words results from the movement of TP into FocP in wh-questions. Adjunct wh-words with wide-scope readings (such as *why* and wide-scope *how*) have no focus features and are generated in spec, IntP; thus, they allow other elements to appear preverbally in FocP.

This difference in behavior between “why” and other wh-words has also been noted in other languages with syntactic focus movement, such as Hungarian. Kiss (1994) notes that in Hungarian, *miért* “why” is the only wh-word that may co-occur with focused constituents:

26. *Miért MARI-t küldte el János a boltba?*  
why Mary-acc sent away John the shop-to  
“Why is it MARY who sent John to the shop?”  
(Hungarian: Kiss 1994, p. 37)

Kiss proposes that in this case, “why” adjoins to a position above FocP, which she argues to be the normal landing position for wh-words.

There is reason to believe, however, this would not work for SLQZ. Evidence against placing “why” (and “how”) in higher surface positions

than other wh-words in SLQZ comes from their behavior in left-dislocated topic constructions. Left-dislocated topics are the only nominals that may appear before wh-words in SLQZ:

27. Gye'eihlly-àa' tu gw-àa'zy Gye'eihlly?  
 Mike-top who perf-hit Mike  
 "What about Mike, who did he hit?"

Furthermore, no material may intervene between topicalized arguments and wh-words in SLQZ. While certain temporal adverbials may be base-generated above wh-words (28), they may not appear between a topicalized argument and wh-word (29):

28. Nài xi b-guhty Gye'eihlly?  
 yesterday what perf-kill Mike  
 "Yesterday, what did Mike kill?"
29. \*Gye'eihlly nài xi b-guhty Gye'eihlly?  
 Mike yesterday what perf-kill Mike  
 "As for Mike, yesterday, what did he kill?"

This suggests that there are no possible landing positions (and thus, no additional projections) between TopP and IntP.

If it were the case that "why" and wide-scope "how" surfaced higher than other wh-words, one would expect that they would be blocked from appearing with topicalized arguments, since TopP is the only remaining projection above IntP. This however, proves not to be the case:

30. Li'eb-àa' xi ni'ih gw-àa'z-ëng Gye'eihlly  
 Felipe-top what reason perf-hit-3s.prox Mike  
 "What about Felipe, why did he hit Mike?"

The fact that all wh-words, regardless of their semantic scope or ability to cooccur with focused constituents, may appear after fronted topics thus suggests that all wh-words surface in the same position in SLQZ.

Furthermore, the interpretive constraints on Hungarian "why" questions with focus suggest that my analysis is amenable to the Hungarian data as well.

Kiss notes that "why" in questions with focused constituents is more constrained in its possible interpretation than it is in other contexts.



Normally, Kiss notes, *miért* “why” may have the reading “what for” in questions:

31. *Miért küldte el János Mari-t a boltba?*  
why sent away John Mary-acc the shop-to  
“Why did John send Mary to the shop?”  
(Hungarian: Kiss 1994, p. 37)

This question may be felicitously answered with a reason (“Because Mary was hungry”) or with the item John wanted Mary to buy (“For bread”).

In the question with “Mary” in focus, however, the second answer is impossible. The question may only be answered with the reason for Mary sending John to the shop:

32. *Miért MARI-t küldte el János a boltba?*  
why Mary-acc sent away John the shop-to  
“Why is it MARY who sent John to the shop?”  
(Hungarian: Kiss 1994, p. 37)

- A. *Mert Mari éhes volt.*  
because Mary hungry was  
“Because Mary was hungry”

- A. \**Kenyér-ért.*  
bread-for  
“For bread”

This absence of the “what for” reading of “why” in questions with overt focus—and its possibility in “why” questions without focus—can be correlated to the presence or absence of [+foc] features on “why”. Recall that the focus feature on *wh*-words forces *wh*-words to select an individual out of a set of possible candidates. Certain kinds of questions (such as those involving reasons and manners), however, cannot have individual elements of sets as answers, only collectives of ordered sets.

The “for what reason” reading of “why” clearly falls into the latter group: on the “for what reason” reading, a question such as “Why did everyone leave?”, for instance, can only be felicitously answered with a complete inventory of reasons why all the people involved left: if five people abruptly left a party, for example, the above question couldn’t be answered with simply the reason why one of the people left. Because the “for what

reason” reading of “why” does not involve selecting an individual out of a group, it does not involve focus.

The “what for” reading, on the other hand, does involve selection of an individual (the thing desired in (31)) out of a group of possibilities. Thus, it is compatible with the function of Focus, and “why” in questions such as (31) (with the “what for” reading) must contain [+foc] features itself.

### 5.2.5 Two Problem Cases: Narrow-Scope “How” and Focus Negation

This leaves two cases still unaccounted for: why “how” on its manner interpretation still shows co-occurrence restrictions with focused constituents, and why *a’ti*’ negation allows wh-extractions. Below, I will address each of these cases in turn.

#### ***Narrow-Scope “How”***

*X:a mo’od* “how” on its manner interpretation is still sensitive to the presence of other focused constituents, as seen in (33), repeated from above:

33. X:a mo’od r-ralloh liu’ [Gye’eihlly yzëhny ]?  
 what way hab-think 2s.inf Mike irr-arrive  
 “How do you think MIKE will arrive?”  
 [e.g., “What makes you think MIKE will arrive?”/  
 \*”By what form of transportation do you think  
 MIKE will arrive?”]

The main difference here is that *x:a mo’od* questions not an entire proposition, but only the manner in which an event is to take place. On its manner interpretation then, *x:a mo’od* is most likely generated within VP, which represents the action being questioned.

I will assume that in this case, *x:a mo’od* raises up through the matrix TP along with the VP in which it is generated. Once the *xa mood*-VP complex has raised into spec, TP, one of two possible movements may take place: either the entire TP, containing the *x:a mo’od*-VP complex, raises up into IntP (perhaps through FocP) or the TP raises into FocP before *x:a mo’od* raises itself in IntP. Movement through FocP in either of these cases may be motivated by the Focus Criterion.

**Wh-Extraction out of a'ti' Constructions**

The final matter that needs to be accounted for is why wh-questions can co-occur with *a'ti'* negation, as seen in (34):

34. Tu a'ti' studya'aann-dya' n-àa?  
 who neg student-dya' neut-be  
 "Who isn't a student?"

This is all the more surprising since negation is known to create, rather than erase, barriers to wh-movement and other A'-movement (Rizzi 1990, Szabolcsi and Zwarts 1993). In Rizzi's terms, the common inability of wh-words to move across negation in a number of languages can be considered a result of Relativized Minimality: an A' specifier, such as a wh-word, cannot raise past an intervening A' specifier, such as an operator in the specifier of NegP.<sup>1</sup> Rizzi argued that this requirement is motivated by the need for wh-traces to be properly governed by their antecedents: if a wh-word A raised past another wh-word B, then the trace of A would be wrongly governed by B, which would be closer potential governor than A:

35. \* wh-A .....wh-B.....tA

This accounts for well-known superiority effects, such as the ungrammaticality of questions such as *\*What did who see?*

Rizzi argues that any A' constituent, such as a negative operator, that intervenes between a wh-word and its trace would result in a grammaticality violation. On the other hand, wh-movement past specifiers in A-positions (such as subjects) is allowed, since A-constituents aren't potential governors for A'-traces. Thus, while *\*what did who see?* is ungrammatical, *what did Bill see?* is fully acceptable.

However, as seen by the SLQZ data, it is precisely the illicit configuration that appears to be allowed (wh-movement past *a'ti'* negation), while wh-movement past an A-constituent (a fronted nonverbal predicate) is disallowed.

The solution I will assume is that wh-words themselves adjoin to *a'ti'* and thus, along with *a'ti'* and the constituent it negates, raise to spec, FocP:

---

<sup>1</sup> Recall from the previous chapter, however, that in SLQZ NegP2 can also behave like a derived A-position when a constituent undergoing A-movement moves into it.

36.

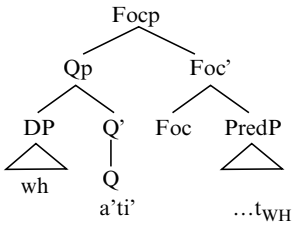

Since specifiers of specifiers (such as the *wh*-word adjoined to *a'ti'*, which itself is the specifier of a larger QP taking the negated constituent as its complement) may c-command constituents outside the projections they are specifiers of, *wh*-words adjoined to *a'ti'* can govern their traces.

From Spec, QP, the *wh*-word then raises to spec, IntP to check its interrogative features and avoid a GDFC violation.

Thus, the A' status of *a'ti'* actually facilitates extraction of *wh*-words because it allows *wh*-words to pied-pipe with *a'ti'* to spec, FocP.

Predicate nominals disallow *wh*-words from adjoining to them and raising with them into FocP: because *wh*-words are A'-constituents, they cannot land in intermediate A positions such as PredP without forming improper chains. Thus, they cannot raise through PredP to FocP along with nonverbal predicates.

Subsequent movement of nonverbal predicates from PredP to FocP to satisfy the Focus Criterion, however, also prevents *wh*-words from raising independently past fronted nonverbal predicates into IntP. Because FocP is already filled with the fronted predicate, the *wh*-word cannot pass through FocP itself to have its focus features checked, and *wh*-movement is thus blocked.

### 5.3 The Syntax of Yes/No Questions

SLQZ forms yes/no questions by marking a sentence with one of three distinct question markers: *laàa'*, and *uu*, which appear question-initially; and *èee*, which appears question-finally. Only one of these markers may appear per question, as seen in the following examples:

37. B-da'uh Gye'eihlly gueht èee?  
perf-eat Mike tortilla Q  
"Did Mike eat tortillas?"
38. Laàa' b-da'uh Gye'eihlly gueht?  
Q perf-eat Mike tortilla  
"Did Mike eat tortillas?"
39. Uu b-da'uh Gye'eihlly gueht?  
Q perf-eat Mike tortilla  
"Did Mike eat tortillas?"

While the same English translation may be used felicitously for all three of the preceding examples, these three markers differ both in their syntactic and semantic distribution: the marker *uu* can only be used in questions for which the speaker expects or wants a positive answer; the marker *laàa'* may only be used to question a proposition introduced into the discourse by the question itself (that is, it may only question new information); and the marker *èee* may only be used to question previously introduced information or presupposed information. In the following sections, I will describe the syntactic differences among questions formed with the different markers, then differences in their usage, and finally, the correlation between their syntactic and semantic features.

### 5.3.1 Syntactic Differences Among the Question Markers

#### **Constraints on *uu* Questions**

Questions formed with the marker *uu* (a typical example is given in (40)) are subject to the largest number of syntactic constraints of the yes/no questions. *Uu* may not be used in questions containing preverbal topics or focused constituents (41-42), nor may it be used in negative yes/no questions (43):

40. Uu b-gyàa'ah Gye'eihlly?  
Q perf-dance Mike  
"Did Mike dance?"

41. \* Uu a Gye'eihlly b-gya'a'?  
 Q top Mike perf-dance  
 "Did Mike dance?"
42. \* Uu Gye'eihlly b-gya'a'?  
 Q Mike perf-dance  
 "Did MIKE dance?"
43. \*Uu cē'ity b-gyàa'-dya' Gye'eihlly?  
 Q neg perf-dance-dya' Mike  
 "Didn't Mike dance?"

Questions with *uu* may contain postverbal, but not preverbal, predicate nominals:

44. Uu n-àa Gye'eihlly do'ctoor?  
 Q neut-be Mike doctor  
 "Is Mike a doctor?"
45. \*Uu do'ctoor n-àa Gye'eihlly?  
 Q doctor neut-be Mike

Questions about future events may appear with Definite-marked verbs, but not Irrealis-marked verbs, in *uu* questions. (The Definite aspect is used to express emphatic speaker belief that a future event will take place; the Irrealis aspect, more commonly used, does not):

46. Uu s-to'oh Gye'eihlly ca'rr?  
 Q def-sell Mike car  
 "Will Mike sell the car?"
47. \*Uu y-to'oh Gye'eihlly ca'rr  
 Q irr-sell Mike car  
 "Will Mike sell the car?"

### **Constraints on *laàa'* Questions**

Questions formed with the question marker *laàa'* (a typical example appears in (48)) show fewer syntactic constraints than those with *uu*. While, like *uu* questions, they can't appear with topics (49), unlike *uu* questions,

they may appear with focus-fronted constituents (50) and in negative questions (51):

48. Laàa' b-gyàa'ah Gye'eihlly?  
Q perf-dance Mike  
“Did Mike dance?”
49. \*Laàa' a Gye'eihlly b-gyàa'ah ?  
Q top Mike perf-dance  
“Did Mike dance?”
50. Laàa' Gye'eihlly b-gyàa'ah ?  
Q Mike perf-dance  
“Did MIKE dance?”
51. Laàa' cë'ity b-gyàa'-(dya') Gye'eihlly?  
Q neg perf-dance-(dya') Mike  
“Didn't Mike dance?”

They may also appear with preverbal, as well as postverbal predicate nominals:

52. Laàa' do'ctoor nàa Gye'eihlly?  
Q doctor neut-be Mike  
“Is Mike a doctor?”

The fact that the question marker *laàa* may co-occur with focus-fronted constituents (as seen in (50) further supports the existence of separate projections for interrogative and focused constituents.

Unlike *uu*, they may form future questions with either Irrealis or Definite-marked verbs:

53. Laàa' s-to'oh Gye'eihlly ca'rr?  
Q def-sell Mike car  
“Will Mike sell the car?”
54. Laàa' y-to'oh Gye'eihlly ca'rr  
Q irr-sell Mike car  
“Will Mike sell the car?”

This contrast will be shown to be directly correlated to the differing semantics of *uu* and *laàa* questions.

### **Constraints on *èee* Questions**

Questions formed with the marker *èee* show the fewest syntactic constraints of the three question types. They can appear with topics (55), focus (56), negation (57), and preverbal and postverbal predicate nominals (58):

55. A Gye'eihlly b-gyàa'ah èee?  
 top Mike perf-dance Q  
 "Did Mike dance?"
56. Gye'eihlly b-gyàa'ah èee?  
 Mike perf-dance Q  
 "Did MIKE dance?"
57. Cë'ity b-gyàa'-(dya') Gye'eihlly èee?  
 neg perf-dance-(dya') Mike Q  
 "Didn't Mike dance?"
58. Do'ctoor n-àa Gye'eihlly èee?  
 doctor neut-be Mike Q  
 "Is Mike a doctor?"

Like *laàa'* questions, they can appear with either Irrealis or Definite marked verbs in future questions:

59. S-to'oh Gye'eihlly ca'rr èee?  
 def-sell Mike car Q  
 "Will Mike sell the car?"
60. Y-to'oh Gye'eihlly ca'rr èee?  
 irr-sell Mike car Q  
 "Will Mike sell the car?"

The structural differences among questions with the three different markers can be summed up as follows:



|                                             | <i>uu</i>     | <i>laàa'</i>         | <i>èee</i>           |
|---------------------------------------------|---------------|----------------------|----------------------|
| Topics                                      | no            | no                   | yes                  |
| Focused arguments                           | no            | yes                  | yes                  |
| Negation                                    | no            | yes                  | yes                  |
| Preverbal predicate nominals/<br>adjectives | no            | yes                  | yes                  |
| Aspects with future                         | Definite only | Definite or Irrealis | Definite or Irrealis |

**Table 3.** Cooccurrence restrictions with yes/no question markers.

### 5.3.2 Contexts for the Three Question Markers

Questions formed with the three markers differ in usage, as well as structure. These differences concern the status of the information being questioned or speaker presupposition about possible answers to the question.

#### *Existential Questions*

Questions involving existential constructions clearly show the contrasting usages of the three question markers. This can be seen in the following examples, which differ from each other only in the choice of question marker:

61. Uu n-u'uh tu ø-zuu loongdèe?  
Q neut-exist who neut-stand outside  
“Is anyone outside?”
62. Laàa' n-u'uh tu ø-zuu loongdèe?  
Q neut-exist who neut-stand outside  
“Is anyone outside?”
63. N-u'uh tu ø-zuu loongdèe èee?  
neut-exist who neut-stand outside Q  
“Is anyone outside?”

These three questions may not be used interchangeably in SLQZ. Rodrigo Garcia, one of my SLQZ consultants, gives the following hypothetical scenarios in which each of these may be used:

The question with *uu* would be used in the following context: Someone who is carrying a large load out of a store and expecting someone to be available to help him or her would pose the question with *uu*. This suggests that the question marker *uu* would be used in cases in which the speaker posing the question fully expects someone to be outside.

A possible context for *laàa'* would be as follows: The speaker posing the question is robbing a house, and wants to make sure he or she can escape undetected. The speaker would then pose the question with *laàa'* to his or her accomplice. (Garcia notes that the question marker *uu* could not be used in this context.) The question marker *laàa'* is thus being used to raise the possibility that someone might be outside.

Finally, the question with *èee* would be used in this situation: The speaker and an accomplice are robbing a house, and as they are about to leave, the accomplice says "Don't go outside!". The speaker would then pose the question with *èee*. Garcia notes that neither *laàa'* nor *uu* may be used to pose the question in this context.

### **The Uses of *laàa'* and *èee***

While *uu* questions are clearly distinct from the other two types of questions in both structure and usage, the difference between the contexts for *laàa'* and *èee* is subtle. The only obvious difference is that in the *laàa'* question, the speaker poses the question without direct prompting, and in the *èee* question, the speaker poses the question in direct response to someone else's comments.

This distinction holds in other questions as well, as the following examples show:

64. *Laàa' n-u'uh tu do'ctoor n-u'uh rèe?*  
 Q neut-exist who doctor neut-exist here  
 "Are there any doctors here?"
65. *N-u'uh tu do'ctoor n-u'uh rèe èee?*  
 eut-exist who doctor neut-exist here Q  
 "Are there any doctors here?"

Garcia offers the following context for the *laàa'* question: while walking down the street, the speaker sees someone being injured in an accident. He or she then goes from building to building, asking if there are any doctors available.

He offers a contrasting context for the *èee* question: the speaker witnesses an accident, and another bystander tells him or her to go to a nearby

building to find a doctor. The speaker could then use the question with *èee* to ask the other bystander to confirm that there are indeed doctors in that particular building. In this case, the question cannot be posed with *laàa'*.

The distinction between (62) and (63) is similar to that between (64) and (65): the question with *laàa'* is posed without input from other speakers, while the question with *èee* is posed in response to information provided to the speaker. This suggests that the choice between *èee* or *laàa'* depends on the information structure of the question: while questions with *laàa'* appear to be used to simultaneously introduce a proposition into the discourse and question it, questions with *èee* are only used to question previously introduced or presupposed information. In short, *laàa'* is used to question new information, while *èee* is used to question old information.

### **More Evidence: Negative Questions**

This generalization is confirmed in the contrasting contexts for negative yes/no question with *laàa'* and *èee*:

66. Laàa' a'ti do'ctoor n-àa Gye'eihlly?  
 Q neg doctor neut-be Mike  
 "Isn't Mike a doctor?"
67. A'ti do'ctoor n-àa Gye'eihlly èee?  
 neg doctor neut-be Mike Q  
 "Isn't Mike a doctor?"

Garcia offers this context for the *laàa'* question: Mike is sick, and the speaker wants to try to cure him with a potentially dangerous experimental medicine. First, however, the speaker wants to make sure Mike is not a doctor so that he won't be aware of what is being done to him.

Here, then, the speaker is simultaneously raising the possibility that Mike isn't a doctor and asking that this be confirmed or denied. The question marker *èee* could not be used to form the question in this context.

A felicitous context for the *èee* question is as follows: The speaker last saw Mike several years earlier, when Mike was in medical school. Now, a mutual acquaintance tells the speaker that Mike is now a lawyer. Here, the speaker would use the question with *èee* to confirm this newly received information: rather than raising the possibility that Mike isn't a doctor, the speaker is questioning someone else's assertion that Mike is not a doctor.

These contexts are thus consistent with the earlier generalization: *laàa'* introduces and questions new information, while *èee* questions old information.

Another contrast between (66) and (67) is a difference in the scope of negation: (66), the question with *laàa'*, can be more appropriately glossed “Is Mike not a doctor?”

A similar contrast appears in another pair of negative examples:

68. *Laàa' a'ti nnsini'cy n-àa Gye'eihlly?*  
 Q neg intelligent neut-be Mike  
 “Isn't Mike intelligent?”
69. *A'ti nnsini'cy n-àa Gye'eihlly èee?*  
 neg intelligent neut-be Mike Q  
 “Isn't Mike intelligent?”

The *laàa'* question would be used in a context such as this: The speaker wants to play a trick on Mike, and is trying to make sure Mike isn't smart enough to catch on.

As in the previous set of examples, the *laàa'* question simultaneously raises the possibility that Mike isn't intelligent and questions it.

A possible context for the *èee* question would be the following: The speaker found out that Mike had unexpectedly failed an easy test at school. The speaker, who had previously assumed that Mike was intelligent, is now questioning the possibility (raised by the news of Mike's flunking the test) that Mike is not intelligent. Garcia notes that the question with *laàa'* cannot be used here.

There are also contexts in which a question may be felicitously poised with *laàa'*, but not *èee*. Garcia volunteers the following context; You are walking down the street with a friend and pass by an interesting-looking restaurant. You then ask your friend if he or she is hungry. In this context, “are you hungry?” can only be asked with *laàa'*:

70. *Laàa' r-dyaàa'n-u'?*  
 Q hab-be.hungry-2s.inf  
 “Are you hungry?”
71. *#R-dyaàa'n-u' èee?*  
 hab-be.hungry-2s.inf Q  
 “Are you hungry?”

Garcia volunteers that the question with *èee*, while not allowed in the context above, would be used if your friend said he/she wanted to eat something before you asked the question.

Pamela Munro (p.c.) suggests that etiquette concerns may be another factor contributing to the pragmatic contrast between (70) and (71): posing the question with *laàa'* may be interpreted as merely making an indirect suggestion, while posing the question with *èee* may be construed as pushy or presumptuous (rather like an English speaker in the same context saying “You’re hungry, right?”). This idea, if correct, however, further supports the idea that *laàa'* and *èee* are distinguished by the status of the information they question: questioning the possibility that a friend might be hungry is less forceful than questioning a preformed assumption that he or she is hungry.

### Some Ambiguous Cases

It must be noted, however, that the propositions questioned in *èee* questions are not necessarily explicitly introduced before the question is asked. In the negative cases above, for instance, no one explicitly tells the speaker that Mike is not a doctor or that Mike is not intelligent. Rather, these facts are inferred from other propositions: the fact that Mike is a lawyer and the fact that Mike flunked an easy test. Thus, propositions questioned in *èee* questions may be (technically) new information in that the speaker is the first one to introduce it directly into the discourse, but they must be propositions that can be inferred or presupposed from previously introduced information.

Thus, the line between contexts for *èee* and *laàa'* questions is potentially blurry. Indeed, there are contexts that may legitimately trigger questions with either *èee* or *laàa'*.

One such context is the following: You are walking down the street with someone and you see Mike wearing a white coat and a stethoscope around his neck. You ask your companion “Is Mike a doctor?” Garcia notes that the question can be posed in either of the following ways:

72. *Laàa'* do'ctoor n-àa Gye'eihlly?  
 Q doctor neut-be Mike  
 “Is Mike a doctor?”
73. Do'ctoor n-àa Gye'eihlly *èee*?  
 doctor neut-be Mike Q  
 “Is Mike a doctor?”

Another potentially ambiguous context is this: You haven’t seen Mike in a week. He then appears looking thinner and paler than before. You ask

a mutual friend who's with you, "Has Mike been sick?". In this context, the question may be posed with either *laàa'* or *èee* :

74. Laàa' r-a'cxùu Gye'eihlly?  
 Q hab-be.sick Mike  
 "Has Mike been sick?"
75. R-a'cxùu Gye'eihlly èee?  
 hab-be.sick Mike Q  
 "Has Mike been sick?"

These contexts meet the criteria previously established for both *laàa'* and *èee* questions. Like other *laàa'* questions, the questions in the contexts above both introduce a proposition and question its truth. Like *èee* questions, however, the questions introduce propositions that can be inferred by both speakers and hearers through real-world knowledge.

### **Contexts for *uu* Questions**

Now I return to the third question marker, *uu*. Questions with *uu* are used when the speaker either expects or wants a positive answer. They cannot be used with negative questions, as previously seen:

76. \*Uu a'ti' do'ctoor-dya' n-àa Gye'eihlly?  
 Q NEG doctor-dya' neut-be Mike  
 "Isn't Mike a doctor?"

They are generally used when the speaker wants to confirm a proposition he or she believes to be true. An example of this appears in (77), repeated from above:

77. Uu n-u'uh tu ø-zuu loongdèe?  
 Q neut-exist who neut-stand outside  
 "Is anyone outside?"

As previously noted, this question would be asked in a situation in which the speaker fully expects someone to be outside.

*Uu* questions may also be used in cases in which the speaker does not necessarily expect a positive answer, but hopes for one. One such situation would be the following: You and a friend are walking down the street and see a small child alone and crying, asking for help in Spanish. You don't speak Spanish, so you ask your friend if he does:

78. Uu r-gwèe-u'            dihzh Stil?  
 Q hab-speak-2s.inf word Spanish  
 "Do you speak Spanish?"

In this case, you don't actually know if your friend speaks Spanish or not, but you hope he does.

Similarly, *uu* may be used in the following context: You see someone being injured in an accident and you immediately try to find a doctor:

79. Uu n-u'uh tu do'ctor n-u'uh rèe'?'  
 Q neut-exist who doctor neut-exist here  
 "Is there a doctor here?"

In this case, the speaker doesn't have any presuppositions about doctors being in the area, only a desire that this be the case.

What the contexts for *uu* questions have in common is the speaker's underlying belief that the proposition questioned is necessarily true—either in the actual world (in the cases in which the speaker presupposes a positive answer to a question) or in a set of possible worlds introduced by the speaker's desire that the questioned proposition be true.

### **Comparing the Syntax and Semantics of the Question Markers**

Now I return to the syntactic differences among the three question markers. In this section, I will account for the syntactic differences between *laàa'* and *èee*, and how these differences reflect their differing semantics.

*Laàa'* and *èee* differ syntactically in only two ways: their respective sentence-initial and sentence-final positions, and their ability to appear with topics.

#### **Why Is *èee* Sentence-Final?**

Question markers crosslinguistically are thought to be generated high in the tree structure. Assuming this is the case in SLQZ, under the principles of antisymmetry, the sentence-final position of *èee* can only be derived by obligatory movement of the body of the question past *èee*. Thus it is conceivable that *laàa'* and *èee* occupy the same preverbal syntactic position, and differ only in the relative position of the rest of the clause:

80.

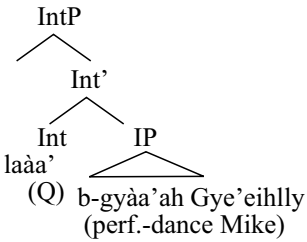

81.

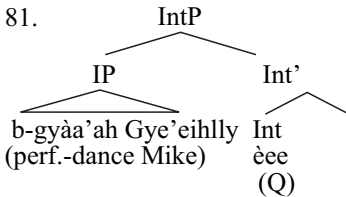

This movement gives the correct linear order. However, it also results in a violation of the GDCF, since both the specifier and head of IntP are now overtly filled. In order to derive a well-formed structure, TP must raise further to a projection above IntP. I assume that this projection is TopP1, the projection that houses left-dislocated topics:

82.

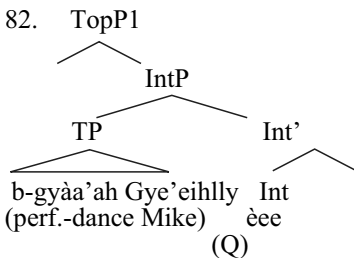

This is supported by the fact that the only elements that may precede sentence-initial question markers and wh-words are vocatives and left-dislocated topics:

83. Gye'eihlly xi b-da'uh Gye'eihlly?  
 Mike what perf-eat Mike  
 "(As for) Mike, what did Mike eat?"

Left-dislocated topics in SLQZ are elements that have already been previously mentioned and are known to both the speaker and listener. Thus, propositions in the LD topic position are interpreted as presupposed or old



information. This is consistent with the previously described semantic constraints on *èee* questions.

### **Why Are Topics Disallowed in *laàa* Questions?**

The second difference between *èee* and *laàa* questions is that the latter disallow fronted topics. The fact that *laàa* questions allow focus, but disallow topics, is puzzling in light of the fact that topics are lower than focused constituents in SLQZ (as seen in (87), where a fronted *a*-topic blocks verb-raising past *al*, ‘already’):

84. Gye’eihlly al b-da’uh bx:àady  
 Mike already perf-eat grasshopper  
 “MIKE already ate the grasshoppers”
85. Gye’eihlly b-da’uh al bx:àady  
 Mike perf-eat already grasshopper  
 “MIKE already ate the grasshoppers”
86. A Gye’eihlly al b-da’uh bx:àady  
 top Mike already perf-eat grasshopper  
 “Mike already ate the grasshoppers”
87. \*A Gye’eihlly b-da’uh al bx:àady  
 top Mike perf-eat already grasshopper  
 “Mike already ate the grasshoppers”

There appears to be no syntactic reason why topics may not appear with *laàa*’ questions. This constraint, however, is consistent with the semantic requirements of *laàa*’ questions: they may only serve to question newly introduced information. Topics are by definition old information, and thus inconsistent with the subcategorization requirements of *laàa*’ questions.

### **The Syntax and Semantics of *uu***

*Uu* questions differ most markedly from those with other markers. This is consistent with its clear difference in usage from the others: its usage is determined by speaker belief about a questioned context, rather than by the question’s information status.

Most strikingly, *uu* questions disallow almost all preverbal structures: topics, focused arguments, negation, and preverbal predicate nominals are all blocked from *uu* questions. At first glance, this suggests that *uu* may be

generated in a lower position than the other question markers: if it is generated below FocP and NegP-1, this would account for the constraints on other preverbal elements: there would be no space for them between *uu* and the body of the question:

88.

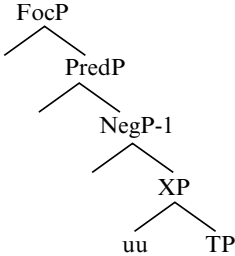

Paradoxically, however, *uu* questions about future events require verbs with the Definite, rather than Irrealis aspect, as seen in the following examples, repeated from above:

89. Uu s-to'oh Gye'eihlly ca'rr?  
 Q def-sell Mike car  
 "Will Mike sell the car?"
90. \*Uu y-to'oh Gye'eihlly ca'rr  
 Q irr-sell Mike car  
 "Will Mike sell the car?"

As previously shown, verbs with the Definite aspect marker differ from other verbs in that they require the propositions they express (and thus the TP containing the verb and its arguments) to raise through MoodP to FocP: this accounts for both their emphatic readings and for the fact that they cannot co-occur with other focus-fronted material. The fact that *uu* may appear with focused Definite verbs suggests that *uu* is generated above FocP, in the same position as other question markers.

The incompatibility of the *uu* question marker with other preverbal constituents is an indirect reflex of the modal features of *uu* questions: they question propositions the speaker either believes to be true or wants to be true. Thus, they introduce into the discourse a set of possible worlds in which the questioned proposition must necessarily be true. These modal features are activated by the movement of the questioned proposition (TP) through MoodP, as with the derivation of sentences with Definite-

marked verbs. MoodP is directly above TP, but below TopP, NegP1 and PredP:

91. Uu b-gyaa'ah Gye'eihlly  
 Q perf-dance Mike  
 "Did Mike dance?"

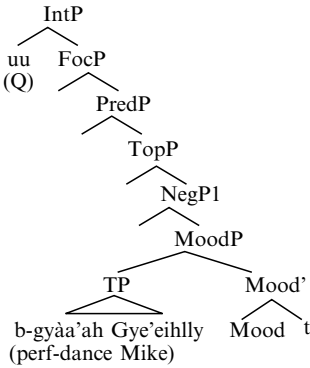

MoodP then raises to FocP. Again, this is parallel to the derivation of sentences with Definite-marked verbs:

- 92.

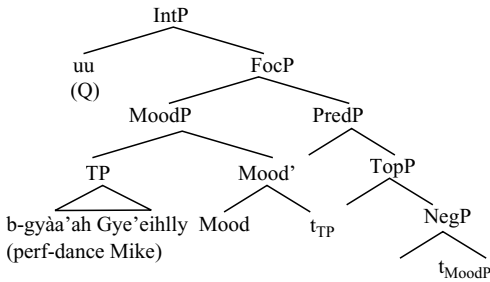

Topics, negation, and fronted predicate nominals are licensed in projections above MoodP, and are thus blocked from appearing under the scope of MoodP. Thus, this structure reflects both the semantic structure of *uu* questions and its syntactic constraints.

## 5.4 Conclusion

This chapter has shown how the syntactic and semantic features of SLQZ questions can be accounted for under the ordering of functional projections established the previous chapter. It also showed evidence for the presence of IntP, a dedicated projection for the licensing of interrogative elements. Also, a syntactic and semantic account was given for the numerous co-occurrence restrictions, noted widely across a range of languages, between focus movement and *wh*-movement. This account showed that while (most) *wh*-movement involves focus movement, it also involves additional movement through IntP. It also provides a unified explanation for the large number of cases in which *wh*-movement and focus can't appear in the same sentence, and the small number of structures in which they can. Furthermore, the existence of IntP is supported by the possible structures of yes/no questions in SLQZ: question markers high in the tree may appear in sentences with focus-fronted constituents, suggesting that interrogative features are checked in a projection distinct from FocP.

## 6 The Interaction of Tense and Aspect in San Lucas Quiavini Zapotec

### 6.1 Overview

SLQZ, like the Zapotec languages generally, expresses temporal functions with verbal prefixes that have traditionally been called aspect markers. (The forms and uses of these markers are described in detail in Chapter 1, and some of the relevant data are repeated below.) In this chapter, I argue, counter to traditional assumptions about Zapotec, that a number of these markers also encode tense features. This is supported by the differing temporal interpretations of these aspect markers in different syntactic configurations, and by constraints on the interpretation of certain aspect markers in matrix clause and embedded contexts. I also show that the syntactically driven constraints on the interpretation on verbs with different aspect markers support recent proposals (Enç 1987, Abusch 1988, Ogihara 1989, Stowell 1993, 1995) that tense is sensitive to syntactic scope. Specifically, the SLQZ data support Stowell's (1993, 1995) model of Tense as a syntactic predicate, as well as his idea that some morphological tense markers are not actual heads of Tense projections themselves, but rather polarity or anti-polarity items sensitive to the presence of tense predicates.

Evidence for the presence of syntactic tense, as well as for the scope-sensitive nature of syntactic tense in SLQZ, comes from the fact that preposed CP complements of verbs with certain aspect markers receive different possible tense interpretations than their in-situ counterparts. The clearest cases of this, which will be discussed below, involve clausal complements of Perfective and Habitual verbs. These data show that the Perfective and Habitual aspect markers, contrary to previous assumptions about Zapotec aspect markers, actually indicate the presence of Past and Present tense, as well as aspect.

## 6.2 “Aspect” Marking in SLQZ

SLQZ expresses tense and aspect by prefixing one of seven aspectual markers to the verb stem. Only one aspect marker may appear per verb stem. I follow longstanding tradition in Zapotec linguistics and refer to these prefixes as “aspect” markers, even though, as I will show, they may encode tense and mood as well.

| Non-modal aspects | Allomorphs    | Modal aspects | Allomorphs      |
|-------------------|---------------|---------------|-----------------|
| Habitual          | r-            | Subjunctive   | n-,ny-          |
| Perfective        | b-,w-,m-, gu- | Irrealis      | ch-, l-, y-, g- |
| Progressive       | ca-, cay      | Definite      | z-, s-          |
| Neutral           | n-, ø-        |               |                 |

**Table 1.** SLQZ aspect markers.

Six of the seven aspect markers are shown in boldface on the verb stem *-tâa’z*, “to beat”, in Table 2:

| Aspect      | <i>-tâa’z</i> , “beat” | Gloss                  |
|-------------|------------------------|------------------------|
| habitual    | <b>rtâa’z</b>          | “beats (regularly)”    |
| progressive | <b>catâa’z</b>         | “is beating”           |
| perfective  | <b>btâa’z</b>          | “beat” (past)          |
| irrealis    | <b>ytâa’z</b>          | “will beat”            |
| subjunctive | <b>ntâa’z</b>          | “was going to beat”    |
| definite    | <b>stâa’z</b>          | “will definitely beat” |

**Table 2.** Aspect markers on a verb stem.

The seventh aspect (the Neutral aspect, realized as the prefix *n-* or as a zero prefix) appears on a small number of verbs (most, but not all, of which are stative or locational):

1. N-âa-ng            banguall.  
neut-be-3s.prox old  
“He/she is old”
2. X:-nnâaan-a’ n-u’        Sann Luu’c.  
poss-mother-1s neut-exist San Lucas  
“My mother is in San Lucas”

(Many of the verbs that allow marking by the Neutral aspect also allow marking by the Habitual aspect. Habitual aspect marking on these verbs

results in an inchoative, rather than stative, reading of the verb. I will discuss this in Section 6.2.1.)

These prefixes across the Zapotec languages have been traditionally referred to as “aspect” markers because they are thought to overtly convey the internal structure of events rather than the temporal relation of the event to the speaker. A simple clause with a verb marked with progressive aspect, for instance, could be used to express a present, past, or future act in progress:

3. Ca-bee’z-a’ liu’  
 prog-wait-1s 2s.inf  
 “I am/was/will be waiting for you”

Similarly, a single Perfective-marked verb can be used to form both past and future perfect constructions:

4. Yzh:ii chih y-zëhny-a’ al b-da’uhw Gye’eihlly.  
 tomorrow when irr-arrive-1s already perf-eat Mike  
 “When I arrive tomorrow, Mike will have already eaten”

Thus, SLQZ (like other Zapotec languages) has no overt verbal morphology for tense. For this reason, it has been assumed that tense plays neither an important syntactic nor semantic role in Zapotec grammar (Black 1994, among others). On closer examination, however, some of the SLQZ aspect markers show the same constraints on possible interpretation associated with tense markers in overtly tense-marking languages. (Examples of standard uses of these aspect markers are given in Chapter 1, and are repeated in the following sections as needed.)

This chapter shows that the Habitual and Perfective markers in particular indicate the presence of syntactic tense, and show the same scopal sensitivities to tense as do the Present and Past tense markers in English. Likewise, the Subjunctive marker shows all the syntactic and semantic features of Past tense. The Neutral and Progressive markers, on the other hand, are indeed purely aspectual, and do not inherently encode any tense features of their own.

The two remaining modal aspect markers, however, show more complicated behavior. The Irrealis marker, which receives either a simple future or subjunctive reading depending on syntactic context, appears to encode Present tense on its subjunctive reading, but not on its simple future reading, where it encodes Future tense. The Definite marker, which can express either emphatic future readings or incompleting events in the immediate past, may encode either Present or Past tense, depending on its context. I will show that the future reading of Definite-marked verbs results not from the presence of Future tense, but from the combined effects of Present tense and the Definite marker’s aspectual features.

Before discussing these phenomena in detail, I briefly discuss the theoretical models of tense and aspect to be assumed in the rest of this chapter.

### 6.3 Theoretical Assumptions

This chapter assumes and shows supporting evidence for Stowell's (1993, 1995) model of tense, based on earlier work by Zagana (1990), Enç (1987), and Abusch (1988). While earlier models of tense treat tense as having referential or operator-like properties (Enç 1987, Partee 1973, among others), Zagana and Stowell treat tense as a predicate. Stowell proposes that tense is the head of a functional projection TP, and is a dyadic predicate taking the utterance time (UT) or other reference time (RT) as its external argument, and the event time (ET) as its internal argument. These temporal arguments are realized as "Zeit-phrases" (ZPs). The head of the tense projection (TENSE) orders these arguments with respect to one another.

For instance, PAST tense is a TP head that orders a reference time of an event (ZP-RT) after the event time (ZP-ET). (In matrix clauses, this external reference time is generally the utterance time.) ZP-ET, in turn, contains an operator that c-commands and controls (= assigns a value to) a temporal argument in spec, VP. This controlled temporal argument within VP, which Stowell calls PRO-ZP, locates the event denoted by VP within this time.

Thus, in a simple past sentence such as *Mike ate the grasshoppers*, the RT (the present time) is ordered after the ET (the time of Mike eating). Since no other temporal arguments syntactically control ZP-RT, it is interpreted as the utterance time (UT) by default. ET, in turn, passes its temporal value to the temporal argument of VP:

5.

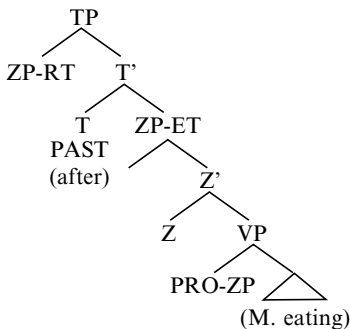

When ZP-RT is controlled by another temporal argument, T takes this time as its external argument, rather than the utterance time. For instance,



in a sentence such as “Tomorrow, Felipe will say Mike ate the grasshoppers”, Mike’s eating is interpreted as necessarily preceding the time tomorrow when Felipe will speak, but need not be interpreted as happening before the present time (when the speaker predicts what Felipe will say). The tense structure of this sentence (with other projections omitted for clarity) is as follows:

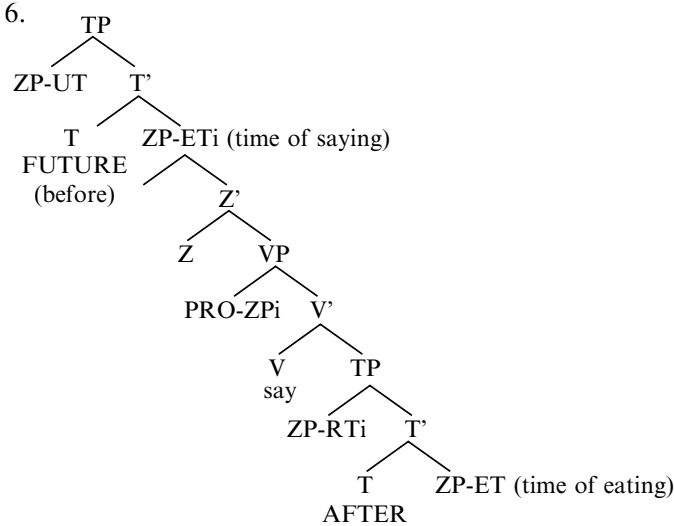

Since TP appears in both the matrix and embedded clauses, it must be the case that there are two separate RTs: the external argument of the matrix clause TP, and the external argument of the embedded clause TP. The external argument of the matrix clause (“Tomorrow, Felipe will say...”) is the UT. Tense in the matrix clause orders UT before the time of the event of “saying”.

As seen in the tree above, the external ZP argument of the embedded clause TP gets its temporal value from the PRO-ZP argument of the matrix clause verb, which takes the embedded TP as its complement. In cases such as this, in which the external argument of Tense is a time other than UT, Stowell assumes that the argument behaves like controlled PRO.

Demirdache and Uribe-Extbarria (1997) (hereafter D&U) expand upon Stowell’s model, and incorporate aspect into the tense system. They propose that aspect, as well as tense, is a time-denoting predicate taking two time-denoting phrases as arguments. Because aspect denotes time intervals within or around an event situated in a particular time, they propose that the aspectual predicate is generated as the complement of the predicate TENSE. Thus Stowell’s ET becomes AspP in their analysis:

7.

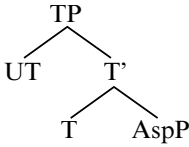

Tense takes the reference/utterance time of an event (UT) as its external argument (as in Stowell’s account), and the assertion time (the time interval focused/selected by Aspect) (AST) as its internal argument.

The head of AspP (which I will refer to as ASPECT, consistent with Stowell’s label of TENSE for the head of TP)<sup>1</sup> takes the assertion time (AST) as its external argument, and the time of the event denoted by the VP as its internal argument:

8.

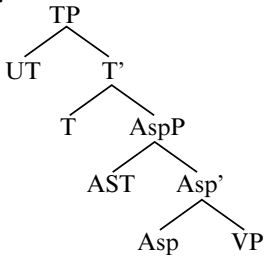

In short, the AST is ordered by both Tense and Aspect.

An example of this can be seen in a simple past progressive expression, such as “Mike was eating grasshoppers”. PROGRESSIVE aspect is a predicate that orders the AST within the period of time in which an event takes place. Thus, AST highlights a point in time during an event in progress. In “Mike was eating grasshoppers”, for instance, AST highlights a point in time within the period in which Mike is eating, and PAST tense orders UT after AST. Thus, AST, the interval of time denoted by “Mike was eating”, is ordered both inside the eating event (by ASPECT) and before UT (by TENSE):

<sup>1</sup> Likewise, following Stowell, I use initial-capped tense/aspect names (Past, Perfective) to refer to the actual tense/aspect markers themselves (such as English Past marker *-ed* and SLQZ Progressive marker *ca-*). Terms expressed in capitals (e.g. PAST) refer to tense predicates themselves, while lowercased terms (“past”) are used in all other contexts.

9.

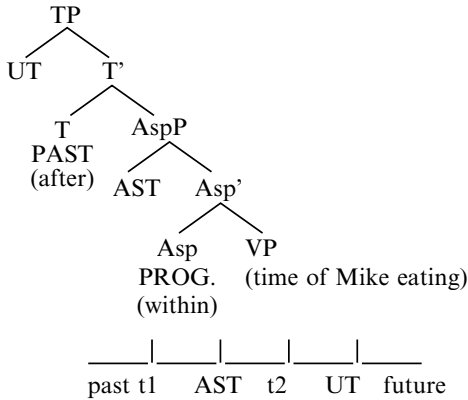

t1=time eating starts, t2=time eating ends, AST=time denoted by “was eating”, UT=utterance time.

There are clearly some differences between Stowell’s and D&U’s proposals that need to be reconciled (such as the question of whether the internal ZP argument of Tense is the same as AST or serves some independent semantic purpose). I will return to this issue, along with the question of the exact syntactic instantiation of these models in SLQZ.

## 6.4 Perfective “Aspect” in SLQZ

Now I address the evidence for tense in SLQZ. One of the aspect markers that most clearly reveals the presence of tense in SLQZ is the Perfective marker. For this reason, I will use the behavior of the Perfective marker to begin this discussion. I will show that the Perfective marker shows a number of semantic features that have been commonly associated with past tense, and that the presence of the Perfective marker is a diagnostic for the presence of PAST in TP in SLQZ.

### 6.4.1 The Distribution of the Perfective Aspect Marker

To reiterate from Chapter 1, the Perfective marker is most commonly used in past, resultative contexts:

10. B-guhty-a’ bzihny  
 perf-kill-1s mouse  
 “I killed a mouse”

It may also be used, however, to express future perfectives (repeated from (4)):

11. Yzh:ii chih y-zěhny-a' al b-da'uhw Gye'eihlly  
 tomorrow when irr-arrive-1s already perf-eat Mike  
 "When I arrive tomorrow, Mike will have already eaten"

Such contexts suggest that the Perfective marker in SLQZ has the canonical features of Perfective aspect: it denotes completed events. In D&U's terms, Perfective aspect can be defined as a predicate PERFECTIVE that orders AST after a completed event:

12.

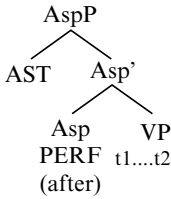

Thus, the interval of time denoted by AST in Perfective contexts is a point after the completion of an event.

When expressing past events, however, the Perfective marker may also denote states without explicit endpoints:

13. G-uhc-ěng nnaa'ah  
 perf-be-3s.prox heavy  
 "He was heavy"

14. B-yuall-a'  
 perf-thirsty-1s  
 "I was thirsty"

There are no attested cases, however, of Perfective marking being used on verbs expressing future states.

An apparent exception, however, is the case of imperatives, which are frequently formed with Perfective-marked verbs:

15. B-ii'lly!  
 perf-sing  
 "Sing!"

I will return to this construction after defining the aspectual features of the Perfect marker, and show that this asymmetry results directly from the interaction of mood and aspect, and is consistent with the definition of PERFECTIVE aspect given above.

## 6.4.2 Embedded Perfective Clauses

In spite of examples such as (15), Perfective-marked verbs in SLQZ show many of the canonical features of Past tense. A context in which these features reveal themselves is the interpretation of Perfective-marked verbs in embedded-clause constructions. In these constructions, the possible readings of embedded Perfective clauses prove to be dependent on the tense features of the matrix clause. This dependency suggests that tense, as well as aspect, is encoded by the Perfective marker in SLQZ.

### *Perfective Under Past-Interpreted Matrix Clauses*

Perfective-marked verbs in complements of matrix verbs with past-tense interpretations may receive either simultaneous or past-shifted readings: that is, the embedded clause past event may be construed as either happening simultaneously with the matrix clause event (the simultaneous reading) or before it (the past-shifted reading):<sup>2</sup>

16. Nài ø-nnaa Gye'eihlly a Li'eb b-ii'lly  
 yesterday neut-say Mike TOP Felipe perf-sing  
 “Yesterday, Mike said Felipe sang”  
 [Felipe was singing at time of saying/  
 Felipe was singing before time of saying]

Complements of “say”, however, are often preposed in SLQZ. Non-preposed complements of “say” are only interpreted as indirect quotations, while preposed complements may be, but aren’t necessarily, interpreted as direct quotations:

17. Ø-nnaa Gyeeihly r-ahcx:ùu'w-a'  
 neut-say Mike hab-sick-1s  
 “Mike<sub>i</sub> said I<sub>j</sub> am sick” / \*“Mike said, ‘I am sick’ ”
18. R-ahcx:ùu'w-a' ø-nnaa Gye'eihlly  
 hab-sick-1s neut-say Mike  
 “Mike<sub>i</sub> said I<sub>j</sub> am sick” / “Mike said, ‘I am sick’ ”

Preposed clausal complements may not co-occur with preverbal arguments or *wh*-words (other than “why”, which may co-occur with preverbal arguments, as shown in the preceding chapter).

<sup>2</sup> *nnaa* “say” is one of a small number of non-locational/stative predicates in SLQZ that takes the Neutral aspect marker. The Neutral marker in the sentences given here may be interpreted with a past-tense reading. To ensure a nonambiguous temporal interpretation of “say”, most of these sentences also include temporal adverbs such as “yesterday”.

19. Guhc  $\emptyset$ -nnaa Gye'eihlly r-ahcx:uu'w Li'eb?  
 when neut-say Mike hab-sick Felipe  
 "When did Mike say Felipe was sick?"
20. \*Guhc r-ahcx:uu'w Li'eb  $\emptyset$ -nnaa Gye'eihlly?  
 when hab-sick Felipe neut-say Mike  
 "When did Mike say Felipe was sick?"

In the previous chapter, I showed that preverbal arguments occupy the Focus projection FocP, and *wh*-words occupy a separate projection that nevertheless has strict co-occurrence restrictions with filled FocP. The fact that preposed complements of "say" share the same distributional constraints as focused constituents suggests that they occupy the specifier of FocP.

When a complement containing a Perfective-marked verb is preposed from a matrix clause with a past meaning, the possibility of a simultaneous reading disappears, and the preposed complement may only receive a past-shifted reading. That is, the event described in the complement clause can only be interpreted as happening before the matrix clause event:

21. A Li'eb b-ii'lly  $\emptyset$ -nnaa Gye'eihlly nài'  
 TOP Felipe perf-sing neut-say Mike yesterday  
 "Yesterday, Mike said Felipe sang"  
 [F. sang before Mike said he did/  
 \*Felipe sang at the same time Mike said he did]

This contrasts directly with (16) (repeated below), in which a non-preposed complement with a Perfective verb may receive either a past-shifted or simultaneous reading:

22. Nài  $\emptyset$ -nnaa Gye'eihlly a Li'eb b-ii'lly  
 yesterday neut-say Mike TOP Felipe perf-sing  
 "Yesterday, Mike said Felipe sang"  
 [Felipe was singing at time of saying/  
 Felipe was singing before time of saying]

The contrasting possible interpretations of (21) and (22) show that the aspectual morpheme itself can't be the only factor contributing to temporal interpretation: if Perfective marking encoded only aspectual features, the ordering of the clauses should not affect their possible tense interpretation. Furthermore, the fact that there is a clear correlation between syntactic structure and possible tense readings suggests that tense is realized as part of the syntax.

The fact that the simultaneous reading of Perfective complements of past matrix clauses is only possible when the complement is *not* preposed—that is, when the Perfective complement is below the matrix PAST

clause—also suggests that Tense is sensitive to scope. This is consistent with a number of recent proposals that note the sensitivity of Tense to scopal factors in a number of languages (Enç 1987, Abusch 1988, Ogihara 1988). In the next section, I will briefly summarize one proposal (Stowell 1993, 1995) that treats Tense as a purely syntactic phenomenon, and treats morphological tense markers as polarity items that need to be in specific scopal relations with the head of TP. I will then show that this model accounts for the SLQZ data in (21) and (22) in a principled way.

### ***Tense Markers as Polarity Items***

Stowell (1995) attributes the possibility of simultaneous or past-shifted readings for past-under-past constructions to the syntactic and semantic requirements of past-tense markers. He proposes that morphological past tense markers (such as English *-ed*) are not actual instantiations of the PAST tense predicate itself, but are polarity items that need to be licensed by PAST. He thus labels such past-tense markers Past Polarity Items (PPIs). Justification for this treatment of past tense markers comes from the fact that their presence does not always translate into an absolute past-tense interpretation. He cites the following example (Kamp and Rohrer, cited in Abusch 1988, p. 19) to show this:

23. John decided a week ago that in ten days at breakfast he would tell his mother that they were having their last meal together.

Recall that Stowell defines PAST tense as a predicate ordering a reference time after an event time. The past auxiliary “were” in the preceding example, however, is problematic for this analysis: the event of “having their last meal together” is neither past with regard to the utterance time, nor with the matrix clause event (the time of John’s deciding) nor with the embedded clause telling event. Rather, “were” is interpreted as simultaneous with “next week”. “Were”, then, cannot be the manifestation of a PAST tense head itself, but only a reflex of PAST in a preceding clause. The simultaneous reading of embedded clauses in past-under-past constructions has long been problematic for analyses of Tense; previous literature proposed that the embedded clause was actually PRESENT tense with regard to the matrix past (Comrie 1985, 1986) and that morphological rules forced past-tense morphology to surface on embedded verbs.

Stowell’s treatment of past morphological markers as polarity items, however, accounts for both simultaneous and past-shifted readings in a principled way. Because Tense is realized as a syntactic head in his model, he takes the necessary licensing conditions for PPIs to likewise be syntactic: PPIs must be within the syntactic scope the predicate PAST. Stowell’s proposal does not lay out specific syntactic conditions for licensing of PPIs, but a relation of structural superiority of TENSE over PPIs (such as *c-command*) seems to be assumed.

In the English example above, then, the two possible readings for the embedded clause result from the presence of two possible licensors: the head of TP in the matrix clause, and the head of TP in the embedded clause.

When the matrix and complement clause events are interpreted as occurring simultaneously, both the matrix and complement clause Past markers are licensed by the same head: the Tense head in the matrix clause, which c-commands both the matrix clause and embedded clause verbs. (The Tense head in the embedded clause is presumably inactive in these cases.) Thus, both the matrix and embedded clause events are interpreted as PAST with regard to the same time: UT.

In cases in which the matrix and complement clause events are interpreted as occurring at separate times, the matrix and embedded clause PPIs are licensed by separate heads: the Tense heads of their respective clauses.

### ***The SLQZ Perfective Marker as a Past Polarity Item***

Now I return to the SLQZ data. Stowell's proposal can easily account for the different possible readings of the SLQZ embedded and preposed Perfective clauses in (21) and (22). I assume that the Perfective marker, besides encoding aspectual features, is also a Past Polarity Item (PPI) (following Stowell 1995) that needs to appear under the syntactic scope of PAST tense. In (22) the simultaneous reading of the embedded clause is possible because the PPI in the embedded clause can be licensed by PAST in the matrix clause. Thus, the matrix clause and embedded clause past times are the same.

In (21) the preposed complement of "say" cannot be licensed by matrix clause PAST tense because it has raised to a position above the matrix PAST head. Thus, the embedded clause must provide its own PAST tense, and the times of the matrix event (saying) and embedded clause event (singing) have to be different. (22) optionally allows the past-shifted reading by allowing PAST to appear in both the matrix and embedded clauses.

This raises the question of why preposed Perfective complements of past-interpreted clauses must have past-shifted readings, and cannot have purely indexical past readings: that is, why can't (21) be interpreted to mean that Felipe was singing at some time in the past with regard to the utterance time, but after the matrix clause event time? The same issue arises in English: an English past-under-past construction such as *Mike said Felipe is sick* can only have a simultaneous or past-shifted reading; there is no possible reading in which the embedded clause event (Felipe's sickness) is interpreted in the past, but after the matrix clause event (Mike's saying).

The English past-shifted case can be accounted for as follows: since the embedded clause remains under the syntactic scope of the matrix clause, the external ZP argument of the embedded clause TP is controlled by the matrix clause ET. When PAST tense is present in both the



matrix and embedded clauses, then, the embedded clause event is obligatorily ordered in the past with regard to the matrix clause past event.

The necessity of past-shifted readings with extraposed Perfective complements in SLQZ is derived in a parallel fashion. In order for a Perfective complement to extrapose, it must contain PAST tense itself in order to license the presence of the Perfective marker. In its base-generated position, then, the external ZP argument of the complement clause TP is controlled by the ET of the past matrix clause event, as in the English case. Thus, in its base-generated position, the embedded Perfective clause receives a past-shifted reading.

When the clause preposes to the matrix clause Focus position, the external ZP argument of the preposed clause TP has no possible binder, and is thus interpreted as UT. Thus, in its preposed position, the complement clause event is interpreted as past with regard to UT.

However, when complement clauses raise out of the matrix clause, both the raised and base-generated copies are interpreted. (Further evidence for the obligatory interpretation of both raised and non-raised copies of clausal complements comes from the behavior of present-under-past constructions, to be discussed below.) The requirement that both copies of the raised Perfective complement in sentences such as (21) be interpreted results in a type of “double access” reading: the Perfective complement is simultaneously interpreted as describing an event that occurred in the past with regard to the matrix clause UT (the reading of the preposed copy of the complement) and in the past with regard to the matrix clause past ET (the reading of the base-generated copy of the complement). Since past-shifted events are necessarily ordered in the past with regard to a present UT, the past-shifted reading results.

### ***Perfective Under Irrealis Matrix Clauses***

The correlation between syntactic scope and tense interpretation is further supported by the interpretation of Perfective-marked verbs in the complements of verbs with Irrealis aspect marking. (Verbs with Irrealis aspect receive future interpretations in matrix clauses) :

24. Yzh:ii y-nnii Gye'eihlly g-uhcx:uu'w Li'eb  
 tomorrow irr-say Mike perf-sick Felipe  
 “Tomorrow, Mike will say Felipe was sick”

Here, Felipe can be interpreted as being sick either before Mike said so or, more naturally, before this sentence was uttered. On the first reading, Felipe may be sick at UT, and the speaker expresses the possibility that Mike will report today’s event of Felipe’s sickness tomorrow. On the second reading, Felipe’s sickness can only be interpreted as already being a past event when the sentence is spoken.

The possibility of these two readings, however, results from the interpretive ambiguities allowed by a single structure. When Perfective

complements of Irrealis verbs surface beneath the matrix clause, the embedded clause RT is controlled by the matrix clause Tense, which thus allows the reading in which the embedded Past event is interpreted as Past with respect to a future time. This is shown in the tree below (projections for focus, agreement, etc. omitted for clarity):

25.

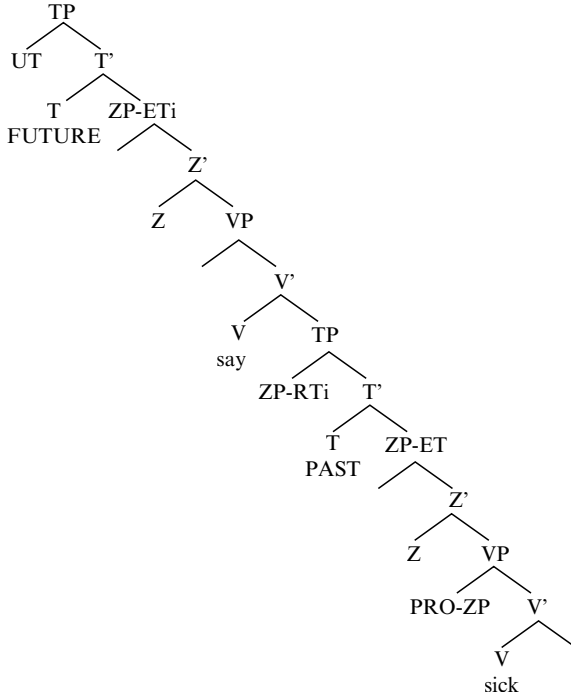

This structure accounts for the two possible readings of (24): the past event in the embedded clause is necessarily interpreted as ordered in the past with regard to the future matrix clause ET. However, nothing in the structure above prevents the embedded clause event from being construed as prior to the matrix clause UT: events ordered in the past with regard to the matrix clause UT are also, necessarily, ordered in the past with regard to the matrix clause future ET, as shown in the timeline below:

26.

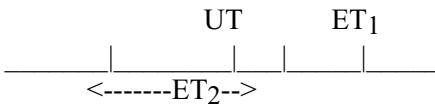

Thus, the embedded clause past event (ET<sub>2</sub>) is ordered before the future matrix clause ET (ET<sub>1</sub>). The ordering between ET<sub>2</sub> and UT,

however, is indeterminate; ET<sub>2</sub> may precede, follow, or overlap with UT, as long as it precedes ET<sub>1</sub>. Thus, (24) may receive readings in which the embedded event is ordered before UT, as well as before the matrix clause future ET.

When a Perfective complement of an Irrealis matrix clause is preposed, however, it may only be interpreted as describing an event occurring before the UT:

27. G-uhcx:ùu’ Li’eb y-nnii Gye’eihlly yzh:ii  
 perf-sick Felipe irr-say Mike tomorrow  
 “Tomorrow, Mike will say Felipe was sick”

This can only mean Mike was sick before UT—that is, Mike’s sickness is already a past event at the time the sentence is uttered.

Like the Perfective-under-past constructions discussed in the previous section, the interpretive constraint on preposed Perfective-under-future clauses is also the result of a double-access reading. When Perfective-marked complements of Irrealis verbs are overtly preposed, the external ZP argument of the complement clause TP gets two separate interpretations: it is controlled by the matrix clause future ET in its base-generated position and it is interpreted as UT in its preposed position (outside the scope of matrix clause tense). Since both the raised and base-generated copies of the Perfective complement are interpreted, the past event in the complement clause must be simultaneously interpreted as past with regard to both the matrix clause ET and matrix clause UT. The only way for both conditions to hold true, however, is for the embedded clause past event to be ordered before the matrix clause UT: events preceding the matrix clause UT are necessarily interpreted as past with regard to the matrix clause future ET. However, the converse does not hold: as seen in (26), events preceding the matrix clause future ET do not necessarily precede the matrix clause UT. Once again, this constraint on temporal interpretation is unexpected if the Perfective marker were a reflex of aspectual features only.

### ***More Evidence: Perfective Aspect in Relative Clauses***

SLQZ Perfective-marked verbs show the behavior of PAST verbs in overtly tense-marking languages in other contexts as well. One such context is in relative clauses, which allow a different range of possible temporal interpretations than other complement clauses containing Past tense.

In English, relative clauses with PAST tense receive only independent interpretations when they appear under the scope of another PAST tense:

- 28 John saw the man who kissed Sandy.

Here, both the times of seeing and kissing are interpreted as before the utterance time, but are unordered with regard to each other: that is, it is possible for John to have seen the man before he kissed Sandy. This contrasts with the possible interpretation of other PAST clauses under PAST verbs, which only allow simultaneous and past-shifted readings.

Stowell argues that the possibility of such unordered tense readings of relative clause events points to obligatory extraposition of the DP containing the relative clause out of the syntactic scope of matrix clause tense (specifically, out of the scope of the external temporal argument of VP.). He suggests that this movement could actually be overt: perhaps it is movement of the relative clause DP out of VP to AgrOP (irrelevant projections omitted below for clarity):

29.

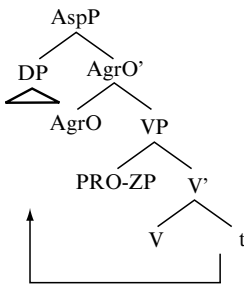

If Perfective aspect marking in SLQZ is a diagnostic for the presence of PAST tense, as has been argued in the previous section, SLQZ Perfective verbs in relative clauses should behave identically to English PAST relative clauses when embedded under matrix clause verbs with past interpretations. This prediction is borne out:

30. B-dëidy Lia Pa'amm li'ebr studya'aann nih g-uhcx:ùuw  
 perf-give Ms. Pam book student REL perf-sick  
 "Pam gave a book to the student who was sick"

Here, as in the English example, the events of giving and sickness are unordered: the student could have become sick after receiving the book, for instance.

The SLQZ data, then, show clearly that tense as well as aspect are present in the syntax and semantics of SLQZ. Furthermore, the difference in temporal interpretation between extraposed and non-extraposed complements of past-interpreted verbs supports Stowell's idea that certain morphological markers associated with tense need to be within the syntactic scope of TENSE.

### 6.4.3 The Interaction of PAST Tense and Perfective Aspect

In the previous section, I showed extensive evidence that the Perfective aspect marker in SLQZ is sensitive to the presence of PAST tense. In this

section, I will discuss its aspectual features and their interaction with Tense, and show that the asymmetric distribution of telic/atelic predicates with Perfective marking under Past and Future tense falls out naturally from the interaction of Tense and Aspect.

If the preceding analysis is correct, then the Perfective marker is a PPI, and must appear in the scope of PAST tense. What remains to be clarified is the content of AspP, and the interaction of the aspectual predicate ASPECT with the Perfective marker.

I will follow D&U’s definition of PERFECTIVE aspect as “a spatio-temporal predicate with the meaning of *after*,” and will show below that this definition consistently accounts for the possible distribution of SLQZ Perfective marking in different semantic contexts. Thus, the tense/aspect configuration that licenses the Perfective marker is as follows: Perfective aspect marking may only appear when licensed by PAST tense, a predicate ordering the external RT after AST, and PERFECTIVE aspect, which orders AST after ET:

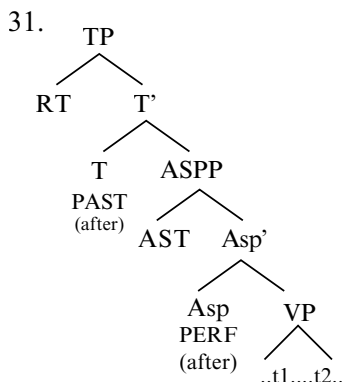

This configuration accounts for all the possible, attested uses of Perfective aspect, while ruling out disallowed usages: when RT refers to the utterance time, a simple past reading results; when it refers to a past or future time, a past perfect or future perfect reading results.

In its most common usage, the Perfective marker in SLQZ is used to describe completed, telic events:

32. B-guhty-a' bzhny  
perf-kill-1s mouse  
“I killed a mouse”

The temporal structure of this sentence is schematized in the timeline below. The event of killing the mouse has fixed beginning and ending points ( $t_1$  and  $t_2$ ). AST is ordered after the end of the event ( $t_2$ ) by PERFECTIVE aspect, and UT, in turn, is ordered after AST by PAST tense.

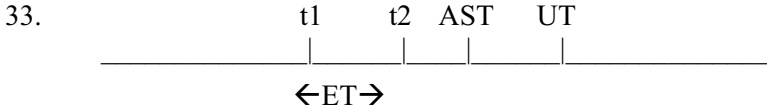

This gives the intended reading of “I killed a mouse”: the speaker is drawing attention to an interval in time after which the mouse has been killed, but before the present utterance time.

Future perfect usages of Perfective aspect can also be accounted for under the tense/aspect configuration shown in (33). Recall from section 6.1 that sentences such as (34) (repeated below) have been used as evidence that Perfective marking encodes only aspect, rather than tense:

34. Yzh:ii      chih y-zēhny-a’    al b-da’uhw Gye’eihlly.  
 tomorrow when irr-arrive-1s already perf-eat Mike  
 “When I arrive tomorrow, Mike will have already eaten”

This reading can be accounted for in the following way: the Perfective marker is licensed by PAST in its own clause, since there is no appropriate licenser (that is, no PAST tense) in the “when”-clause. The external argument of TENSE in the Perfective clause, however, is controlled by FUTURE Tense in the “when” clause:

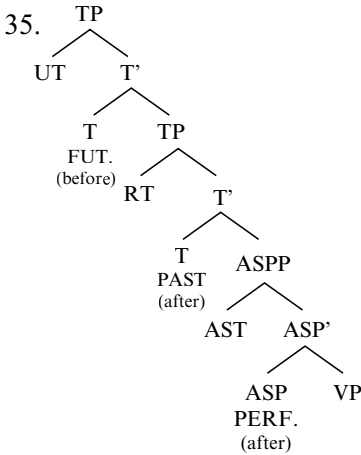

This results in the following interpretation of the Perfective-marked verb: PERFECTIVE aspect orders AST after ET (the time of eating) (thus, after t2), and PAST orders RT (the time of arriving) after AST. FUTURE tense in the “when”-clause, in turn, orders UT before RT.

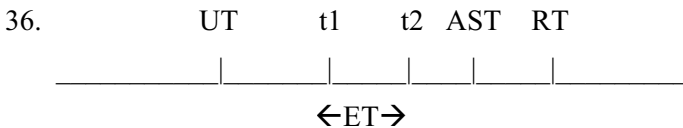

This results in the correct reading: there is a time in the future (the time of arriving) at which an event of eating is already completed.

Note, however, that nothing in the definitions of PAST tense or PERFECTIVE aspect given above forces AST and ET to follow UT in future perfect contexts: (34) would still be a true and valid sentence if Mike finished eating before UT. The same seems to hold for future perfect constructions in English:

37. When I arrive tomorrow, Mike will have sent out the letter. As a matter of fact, he probably sent it out already.

Thus, another valid configuration for future perfect structures is as follows:

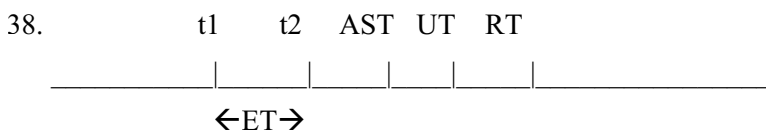

Thus, the interpretation of future perfect constructions as PERFECTIVE aspect embedded under PAST and FUTURE tenses accounts for both the PPI status of the Perfective marker and the ability of the Perfective marker to participate in future readings. It also accounts for the flexible interpretations available to Perfective-marked verbs in future constructions.

It should be noted, however, that the derivation of the future perfect reading in (34) cannot be extended directly to English: in English, the same tense must appear in both the “when”-clause and the main clause, and perfective participles must appear with tensed auxiliaries:

39. When I arrived, Bill left/\*leaves.  
 40. When(ever) I show up, Bill leaves/\*left.  
 41. When I arrive tomorrow, Bill (\*will) have already left.

I have no account for this difference; I leave this matter aside for future investigation.

Thus, D&U’s definition of PERFECTIVE aspect, combined with the SLQZ requirement that Perfective-marked verbs be licensed by PAST tense, accounts for the temporal interpretation of telic events in a straightforward way. But how can PERFECTIVE aspect, which orders AST after the completion of an event, be used felicitously with states and atelic events, which have no defined starting points or endpoints? As seen in (13) and (14), there are clear constraints on the use of Perfective marking in stative contexts: Perfective-marked verbs may describe past states,

but not future ones. This constraint, too, falls out as a natural result of the interacting requirements of PAST tense and PERFECTIVE aspect.

The requirement that Perfective-marked verbs be licensed by PAST tense rules out the use of Perfective aspect in descriptions of future states. Consider the following:

42. G-uhc-ëng nnàa'ah  
 perf-be-3s.prox heavy  
 \*‘‘He will be/will have been heavy’’

Unlike the future perfective sentence in (34), this sentence has no modifying adverbial or matrix clause containing FUTURE tense. Thus, there is no possible future external reference time for the PAST verb, and thus no way for the state of being heavy to be interpreted as occurring after UT. Below is the schemata for the intended reading of the sentence:

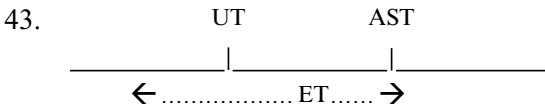

Here, UT is ordered before AST (giving the future reading of the sentence), and AST is ordered after the event (ET) by PERFECTIVE aspect. As in the past stative cases, AST provides a default endpoint to ET.

This schema, however, violates the requirement that Perfective aspect in SLQZ be under the scope of PAST tense: as shown above, Perfective aspect wrongly appears under FUTURE tense, violating the requirements the Perfective marker PPI places on Tense. Thus, the disallowal of future states descriptions with (unmodified) Perfective aspect can be ruled out.

Now consider the case of Perfective-marked verbs denoting past states:

44. G-uhc-ëng nnàa'ah.  
 perf-be-3s.prox heavy  
 ‘‘He was heavy’’

This is most naturally interpreted as meaning the person under discussion was heavy during some undefined length of time in the past, but is no longer heavy now.

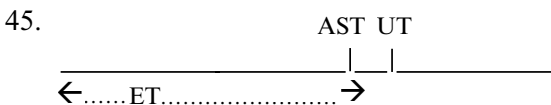



Because “be heavy” denotes a state, rather than a telic event, it has no readily definable beginning or ending point in time (unless provided by context, or adverbial expressions). Since PERFECTIVE aspect orders AST after ET (in this case, ET being the time during which he was heavy), the state of heaviness must be construed as beginning (and ending) at some point before AST. Since PAST Tense orders UT after AST, the state of being heavy must end before AST for the sentence to be interpretable. Thus, AST provides a default endpoint for the event, and the sentence gets its natural interpretation: “he was heavy” from some undetermined (or contextually defined) time in the past until some point (AST or a point before AST) before the utterance time.

#### 6.4.4 A Potential Counterexample: Perfective Imperatives

Now I return to the case of imperatives, the one construction in which the Perfective marker does not encode a past event:

46. B-i'i'ly!  
       perf-sing  
       “Sing!”

A potential correlation between the use of the Perfective aspect, normally used to express past events, and imperatives, used to describe possible future events, comes from Iatridou (2000), who notes that both Modern Greek and English use past morphology in expressions of counterfactual and hypothetical events (such as “If you went to Oaxaca, you would love the food”), and that the past morphology in these contexts does not encode actual past tense. However, SLQZ, unlike Modern Greek and English, does not use the same verbal tense/aspect morphology in conditional constructions and normal past-tense constructions.

A stronger correlation comes from Hyam’s (to appear) analysis of children’s use of Modern Greek bare perfectives: Modern Greek, like SLQZ, does not employ infinitival verb forms; inflected verbs may appear with independent tense, aspect, and mood markers. Small children acquiring Modern Greek often use verb forms with perfective aspect marking, but no tense marking; Hyams argues that these forms correspond to the root infinitival constructions used by young children learning English and other languages with infinitival verb forms.

Hyams also notes a strong tendency for children to use bare perfectives in modal contexts, particularly those expressing commands or desires:

47. Kupisi i kateti  
       wipe.perf.3s. the mirror  
       “I want to wipe the mirror”  
       Modern Greek: Hyams, to appear

Following Barbiers 1995, Hyams adopts the following hypothesis for a correlation between perfective aspect and deontic modality: Deontic modality, unlike epistemic modality, involves a polarity transition, that is, it necessarily encodes a “switch” from a situation when an event has not been realized to one in which it is fully realized (or at least, is desired to be fully realized). Perfective aspect encodes a similar polarity transition, from a point in time in which an event hasn’t been completed to a point in time where it has been completed. Hyams thus proposes that deontic modality and perfective aspect both encode a “transition feature” that can operate both over worlds (in the modal cases) and periods of time (in the aspectual cases). Children who have not yet acquired the adult modal forms can thus use bare perfectives to encode mood and to check mood features syntactically (via verb movement to MoodP). (Hyams notes that children under 4 can express deontic, but not epistemic, modality.)

Returning to SLQZ, I will assume that the Perfective marker on imperatives is defective and lacks PAST tense features. Instead, it encodes only Perfective aspect and mood, and, like child bare perfectives in Greek, can check both aspectual and mood features. Thus, like Greek bare perfectives, SLQZ imperative verbs raise to MoodP to realize their deontic modal readings. This is also consistent with Hyam’s analysis of imperatives as non-finite (that, is tenseless), and Zanuttini’s (1994, cited in Hyams, to appear) observation that infinitival verbs in Italian may be used in imperative constructions:

48. Non telefonare!  
 neg call.imp.  
 “Don’t call!”

Italian: Hyams, to appear.

## 6.5 The Syntax of TP: Reconciling Predicate TENSE with VP-Raising

The precise application of Stowell’s proposal to the syntactic structures outlined for SLQZ in previous chapters of this work, however, raises a number of questions: Stowell assumes that the positions in TP occupied by ZP-UT/RT and ZP-ET are distinct from positions occupied by actual nominal and clausal arguments. In his 1993 and 1995 papers, he thus assumed the possibility that TP has multiple specifiers, one for nominal arguments and one for the external argument of TENSE.<sup>3</sup> This idea is also suggested by D&U. This possibility clearly violates Antisymmetry constraints, which state that all syntactic relations can be reduced to those between a single specifier, a head, and a complement.

<sup>3</sup> Another possibility he raises is that subjects don’t land in spec, TP.

Furthermore, the semantic functions of TENSE appear to be at odds with my proposal that VP remnants raise through spec, AspP into spec, TP: if Stowell's account is correct and VPs themselves contain temporal arguments that need to be controlled by the internal ZP argument of TP, then there is no way for VP itself raise into spec, TP (which houses the external ZP argument of TENSE) without violating this requirement. If the head of TP itself is a predicate that takes distinct internal and external arguments, and if projections can have at most one specifier (per Kayne), this would mean the VP-remnant itself would have to serve as both the internal and external argument of TP, if Stowell's proposal is to hold. In short, VP-remnants would have to raise from the complement of TP (from the internal argument position of T) to the specifier of TP (the external argument position of of T), or even higher:

49.

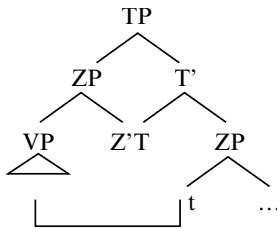

Similar problems result for the analysis of aspect: if D&U are correct and AspP is a predicate taking two arguments, and if VPs raise from their base position through the specifier of AspP, then VP must simultaneously be posited as both (part of) the internal argument of AspP and its external argument. Since it is generally held that no argument may take more than one thematic role (and thus be assigned both internal and external argument positions), there is a clear problem in reconciling Stowell and D&U's models of tense and aspect with the previously outlined VP-raising model of SLQZ.

Stowell also assumes that the ZP arguments of TP are interleaved with other functional projections (such as AGRSP and AGROP), and are transparent to movement through these projections. This forces the question of where these ZP arguments are generated, and how they can account for the constraints on tense interpretation in SLQZ.

Another question raised by the reconciliation of obligatory VP-raising and Stowell's tense theory is the independent temporal interpretation of relative clauses with past-interpreted verbs: recall from the preceding section that past-interpreted relative clauses are interpreted as unordered in time with regard to past-interpreted matrix clause verbs. Stowell (1995) suggests this occurs because relative clauses (or DPs containing them) raise out of VP (and the temporal argument in the spec of VP) into agreement projections for case-marking purposes, and thus cannot be interpreted as under the scope of matrix clause tense. This analysis is likewise

problematic for a VP-remnant-raising analysis: since all arguments, both clausal and nominal (including relative clauses) generated within VP necessarily raise out of VP before VP raises in to TP, then both nominal and clausal complements of a verb should be expected to be interpreted as temporally independent from the verb. But as seen above, this is not the case; SLQZ shows the same asymmetries between the temporal interpretation of relative clause and clausal complements as languages assumed to employ verbal head-movement, such as English.

In short, there are two basic problems in reconciling the VP-remnant-raising analysis of SLQZ syntax with Stowell/ D&U's syntactic accounts of TENSE and ASPECT: (1) where VP raises to in the TP complex and (2) why nominal (relative clause) and clausal complements show different dependencies on matrix clause tense if both necessarily raise out of VP (and thus out of the syntactic scope of the temporal argument in spec, VP).

I will assume that the basic structure of TENSE and ASPECT proposed by Stowell and D&U is correct. The external temporal argument of VP (PRO- ZP) has a logical thematic position in the previously outlined internal structure of VP in SLQZ: the specifier position of VP<sub>asp</sub>, the outermost VP shell:

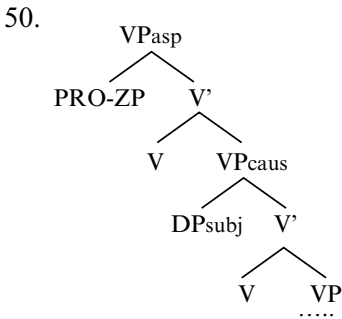

This analysis is consistent both with the semantic function of VP<sub>asp</sub> (to introduce a verbal predicate that denotes spatiotemporal location) and enables Stowell's proposal that temporal variables are generated in spec, VP to be reconciled with the antisymmetry-driven requirement that each projection have only one specifier. In D&U's terms, the external argument of VP<sub>asp</sub> represents AST, the external argument of AspP and the internal argument of TP.

Under Stowell's model, the temporal argument of VP is a variable that is bound (hence, c-commanded) by an operator in the internal ZP argument of TENSE. Thus, the event denoted by VP gets a temporal value by being under the syntactic scope of Z

I will suggest that in SLQZ, where VP remnants raise for feature-checking purposes, the VP raises into and surfaces in the specifier of the internal ZP argument of TENSE:

51.

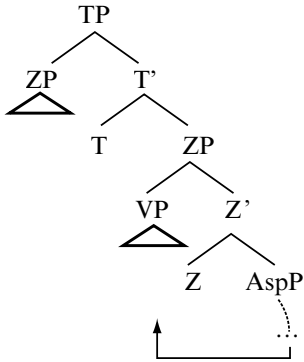

Thus, the temporal features of PRO-ZP in VP<sub>asp</sub> are checked by specifier-head agreement within ZP, rather than c-command by Z. This is consistent with Minimalist assumptions that all agreement and feature checking is licensed via spec-head agreement (Chomsky 1992, 1995), and is also consistent with the fact that VP is interpreted as an internal argument of TENSE. In short, VP does not raise into TP itself, but into one of the ZP arguments selected by and generated by TP.

This account is also consistent with the scope-sensitive nature of PPIs such as the SLQZ Perfective marker: under this analysis, the Perfective marker in the outermost VP shell surfaces under TP, and thus is properly licensed.

Kural (1998) likewise proposes a similar account for English verb-movement: he argues that English verbs raise to the head of the ZP complement of T. Kural's argument is motivated by the discrepancy between the well-known evidence against movement of English verbs out of VP into INFL/Tense (such as the fact that lexical verbs may not raise past clausal negation (*\*He likes not anchovies*) nor appear higher than certain adverbs (*\*He eats often anchovies*) and the behavior of causative constructions with unaccusative verbs, which suggest the presence of verb movement out of VP.

His evidence for verb movement in causative constructions comes from his analysis of constructions such as the following:

52. Mary often made him arrive late.

Following Burzio (1986), Kural assumes that unaccusative verbs such as *arrive* take a single internal argument, base-generated as a complement, but do not assign accusative case. Thus, AgrOP in the complement clause is unavailable, and the accusative case on *him* in (50) must result from *him* raising to AgrOP in the matrix clause.

If this is so, however, it must also be assumed that the verb *made* has raised out of VP. Since AgrOP is generated above VP, yet the verb appears above *him*, which Kural assumes to have raised to matrix clause AgrOP, the verb must be in a position above AgrOP itself. Yet the fact that the

verb is preceded by *often* also suggests that the verb could not have raised as high as TP. Thus, the verb must have raised out of VP and past AgrOP, but not as high as T. Kural thus suggests the internal argument of TP, ZP as an appropriate landing position for English verbs.

Aspectual features are checked in the following way: the event time of VP itself, per D&U, serves as the internal argument of AspP. The AST (the PRO-ZP argument of VP<sub>asp</sub>, in my terms) serves as the external argument of AspP and the internal argument of TP.

There are two possible ways for VP to be realized as the internal argument of AspP: either (1) VP itself, in its base-generated position below the subject and object agreement projections, serves as the internal argument of AspP, or, (2) parallel to Stowell's model of Tense, the relationship between AspP and VP is moderated by an internal ZP argument of AspP, which assigns a temporal value to VP. For the sake of consistency, I will assume the latter possibility: AspP takes as its complement a ZP argument, which assigns a temporal value to VP. VP raises into spec, ZP, parallel with its movement into ZP in TP, to check these features:

53.

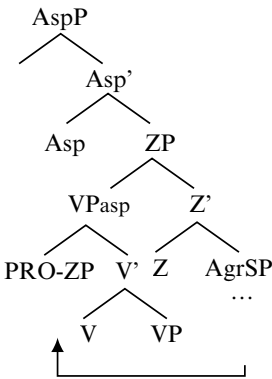

VP<sub>asp</sub> then raises into spec, AspP, where the features of PRO-ZP in the specifier of VP<sub>asp</sub> are checked:

54.

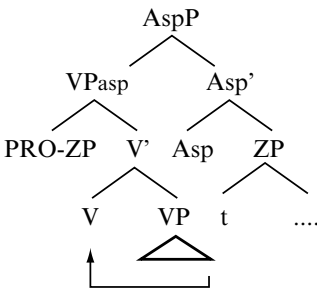

From this point, VP<sub>asp</sub> raises to the specifier of the internal ZP argument of TP.

This still leaves open the question of why relative clause arguments in SLQZ remain temporally independent of the clauses that select them, while clausal complements do not. I will argue that this difference results from the inherently different structural requirements of nominal and clausal arguments. Stowell (1981) proposes that case-assigning categories (such as tensed CPs) may not appear in case-marked positions (the Case Resistance Principle, summarized in this work in Chapter 3). Conversely, case-receiving categories (specifically, nominals) may not assign case. As shown in the previous chapters, however, both nominal and clausal arguments raise out of VP into specific licensing positions before the VP itself actually raises into the domain of TENSE. It must be the case, then, that the positions that license nominal arguments (AgrSP and AgrOP) are case-assigning positions, while the projection that licenses clausal complements (LP) is not.

This generalization can be reformulated in the following way. As previously described, clausal arguments inherit some of the tense features of matrix clause verbs, while nominal arguments do not. Thus, projections that are assigned case may not inherit tense features; and projections that inherit tense features may not be assigned case.

A possibility I will consider here, consistent with this generalization, is that the LP position where complement clauses surface is a ZP projection: like the internal ZP argument of TP, it assigns a temporal value to a projection in its specifier. ZP-LP, as I will call this projection, is controlled by the internal ZP argument of TP. Thus, the external temporal argument of any embedded clause is indirectly controlled by the ZP argument of TP, as Stowell’s theory predicts. The AgrP projections into which nominal arguments of VP raise lack such temporal features; thus, events expressed within relative clauses may be interpreted with any time as their external argument.

## 6.6 Habitual “Aspect” in SLQZ: Evidence for PRESENT Tense

Another aspect marker that shows interpretive effects associated with Tense is the Habitual marker *r-*. The Habitual marker, as its name implies, is used to denote ongoing or regularly repeated states or events:

55. Tu r-yu’lààa’z Li’eb?  
 who hab-like Felipe  
 “Who does Felipe like?”

56. Zë'cydihs r-yennlààa'z Gyeeihly y-gyaan Gye'eihlly bèe'cw  
 always hab-forget Mike irr-feed Mike dog  
 "Mike always forgets to feed the dog"

It is also used to express present perfect readings with stative predicates:

57. A g-uhc tsèi'ny wbihzh r-ahcx:ùu'w Gye'eihlly  
 already perf-be fifteen day hab-sick Mike  
 "Mike has been sick for fifteen days"

This is similar to the pattern seen in Romance languages, which use simple present tense in stative contexts in which English uses the present perfect.

Habitual-marked verbs in complements of verbs with past readings behave like English present-tense verbs: they allow only double-access readings (that is, readings in which the embedded verb is interpreted as "present-tense" both in relation to the UT and to the past time denoted by the matrix clause). This reading can be seen in the following English example:

58. Pam said Marcy is sick.

This gets the interpretation that Marcy was sick both at the past time when Pam said she was, and is also sick at UT. In other words, if PRESENT tense is a predicate establishing an overlapping relationship between a reference time and an event time (per Stowell), then Marcy's sickness is construed as overlapping two different event times: the present time (UT) and the past time provided by matrix clause ET.

The double-access reading results in SLQZ whether or not the complement clause is preposed:

59. R-ahcx:ùu'w Li'eb ø-nnaa Gye'eihlly nài'  
 hab-sick Felipe neut-say Mike yesterday  
 Yesterday, Mike said Felipe is sick"  
 [F. was sick then, is sick now]
60. Nài' ø-nnaa Gye'eihlly r-ahcx:ùu'w Li'eb  
 yesterday neut-say Mike hab-sick Felipe  
 "Yesterday, Mike said Felipe is sick"  
 [F. was sick then, is sick now]

This cannot mean Felipe was sick yesterday but not now, nor that Felipe wasn't sick yesterday but is now. This, along with the fact that Habitual marking is not used to express past states, suggests that the Habitual marker is a Past Anti-Polarity Item (PAI) (per Stowell 1995): it must *not* be governed by PAST tense. Following Stowell, I assume that PAIs encode PRESENT tense, and thus the Habitual marker must be licensed by PRESENT.



Stowell argues that the obligatory double-access readings of present-under-past sentences result from the PAI status of present-tense markers: in English examples such as (58), the embedded clause must obligatorily raise out of the scope of matrix PAST tense by LF. This raising allows the embedded clause PRESENT tense to take UT as its external argument, and thus be interpreted as simultaneous with UT. On the other hand, the fact that the embedded clause is generated (and surfaces as) a complement of the matrix clause PAST verb allows the PRESENT-tense verb to be interpreted under the scope of PAST and inherit the matrix clause ET as its external RT.

The SLQZ facts are consistent with this hypothesis. The obligatory double-access readings of Habitual clauses under past-interpreted clauses can be posited as the result of raising of the complement out of the matrix clause at LF. The double-access readings of overtly extraposed Habitual clauses result from reconstruction.

Further evidence that Habitual markers are PAIs comes from their interpretation when embedded under future matrix clauses. When Habitual-marked verbs appear in complements of future clauses, they receive future-shifted readings:

61. Yzh:ii y-nnii Gye'eihlly r-ahcx:ùu'w Li'eb  
 tomorrow irr-say Mike hab-sick Felipe  
 “Tomorrow, Mike will say Felipe is sick”  
 [F. will be sick at time of saying]

My consultant gives this the following interpretation: Mike knows Felipe will be absent from some obligation the next day, and plans to cover for him by saying he is sick. Thus, the external RT argument of the embedded clause is controlled by the matrix clause ET.

In contrast, when the Habitual-marked complement is preposed, a double-access reading results: the complement clause event is construed as simultaneous with both the matrix clause UT and the matrix clause ET:

62. R-ahcx:ùu'w Li'eb y-nnii Gye'eihlly yzh:ii  
 hab-sick Felipe irr-say Mike tomorrow  
 “Tomorrow, Mike will say Felipe is sick”  
 [F. sick both now and tomorrow]

Like the present-under-past cases above, the double access reading here can be attributed to reconstruction: fronting of the complement clause leaves the external argument of PRESENT tense unbound, so it takes UT as its value. LF reconstruction of the complement back into its embedded position places the external clause RT under the scope of matrix clause PAST, and it gets its value from matrix past ET.

### 6.6.1 The Aspectual Features of the Habitual Marker

As argued above, the Habitual marker is a PAI that may only appear out of the scope of PAST tense, and must be licensed by PRESENT tense. But how does ASPECT treat the Habitual marker?

The HABITUAL aspectual predicate, like PERFECTIVE aspect, is a spatiotemporal predicate that establishes a temporal/locational relationship between AST and ET. I will argue that the HABITUAL aspect predicate (HAB for short) establishes a relationship of containment between AST and ET. In other words, Habitual-marked verbs denote events in which the assertion time (the time being highlighted/focused by the speaker) contains the event time. This definition of HAB, along with the PAI status of the Habitual marker, are combined in the following tense/aspect configuration:

63.

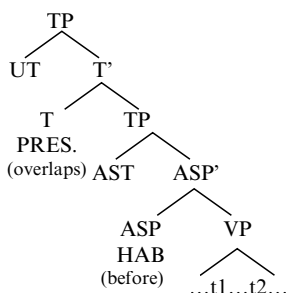

This configuration accounts for all and only the allowable usages of the Habitual aspect marker in SLQZ. Below, I will consider in turn each of the contexts in which HABITUAL aspect may appear: in the description of atelic states, present perfect readings of stative verbs, and habitually repeated telic events.

#### **Atelic Events/States**

As mentioned earlier, Habitual aspect is used to describe ongoing, present-tense states when used with atelic verbs:

64. R-yu'lààa'z Li'eb Gye'eihlly  
 hab-like Felipe Mike  
 "Felipe likes Mike"

Because the state of liking Mike has no fixed beginning point or ending point, ET is assumed to include all times (or at least, all points in time during a contextually relevant period, such as Felipe's lifetime). HAB orders ET inside AST, so the speaker is highlighting a period of time containing

the time during which Felipe likes Mike, and is thus asserting that it is always the case that Felipe likes Mike.

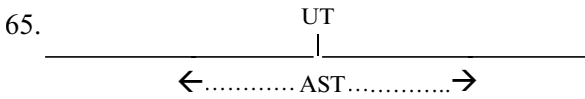

PRESENT tense, in turn, orders UT simultaneous with AST. The required presence of PRESENT tense correctly blocks Habitual-marked verbs from denoting states that do not overlap with UT.

### **Telic Events**

The habitual, iterative interpretation of telic events described with Habitual-marked verbs can also be accounted for by the definition of HAB proposed above. Consider, for example, a Habitual sentence with a telic verb such as the following:

66. R-uhny-nèe Gye'eihlly Li'eb tarèe  
 hab-do-with Mike Felipe homework  
 “Mike does homework with Felipe”

This does not necessarily mean that Mike is doing homework with Felipe at the moment the speaker says this sentence. Rather, it has the same meaning as its English gloss: that there are repeated intervals, within some contextually determined period of time, during which Felipe does homework with Mike. This can be schematized as follows:

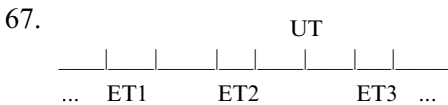

This use of the Habitual marker relies most crucially on the idea that AST contains the event time. As seen in (65), AST is not a single point in time with a temporal relation to a single event time, but rather a period of time that includes a set of discontinuous event times. (65) shows, as the reading of (66) predicts, that UT need only be within AST; it is not necessary for UT to overlap in time with any of the actual events of doing homework. In short, the speaker who utters (66) is not actually describing an event or events, but is pointing out a state of affairs in which such events exist. This stative reading of Habitual-marked telic verbs results in their generic flavor.

The definition of HAB outlined above shows a number of parallels with Chierchia's (1992) analysis of habitual constructions. He analyses habitual constructions as a subset of generic constructions: in the semantic model he argues for, generic readings result when a generic operator (Gn) is generated in Asp, and scopes over felicitous situations in which the generic or habitual event occurs. For instance, a sentence such as "Fred smokes" has the following semantic representation:

68. Gn s[C(f,s)][smoke(f,s)][Chierchia 1992, p. 26]  
f= Fred

C (the context variable) represents the felicitous contexts in which Fred's smoking may occur (he must be awake, he must have his lighter with him, etc.). C is bound by Gn, which also binds the argument s, which represents situations in which Fred smokes. Thus, the fact of Fred being a smoker would hold true even during the times in which he is not smoking.

Like the definition of HAB argued for previously, Chierchia's account captures the fact that it is not necessary for an event to be perpetually ongoing for it to be generically or habitually true. A particularly salient parallel between his analysis and mine is that he posits the generic operator to be generated in AspP: while aspect is most commonly defined as a description of the internal temporal structure of an event (Chung and Timberlake 1985), Chierchia shares my intuition that genericity/habitual readings, which potentially take scope over a series of events, can be most appropriately be handled as an aspectual feature.

Chierchia's account, however, diverges from mine in several respects. For one, he specifically associates the generic readings of habitual constructions crosslinguistically to the presence of the Gn operator: morphemes that encode habitual aspect, he argues, are polarity items that must be under the scope of Gn. This certainly cannot be the case in SLQZ, where Habitual-marked verbs are often used with non-generic readings (such as present perfect constructions, for instance).

Also, there are clear advantages to positing the generic flavor of Habitual readings as a natural result of the definition of HAB itself: for one, it leads to a simpler, more uniform syntactic and semantic representation. Chierchia does not explicitly define exactly what the Gn operator does, and indeed states that this would be extremely difficult to do (p. 28-29). Genericity in my account is a natural side effect of the function of AST under HAB; there is no need to posit the existence of additional operators. This also allows HAB to be treated as structurally parallel to other aspects: the aspectual predicate itself does all the work. Another advantage of my approach is that it allows stage-level and individual-level predicates marked with Habitual aspect to be treated uniformly: differences in their interpretation under Habitual aspect result from their own thematic structure, not from different treatments by ASP.

The remaining fact that needs to be accounted for is why HAB necessarily results in readings in which an event denoted by a telic verb repeats itself multiple times. If the schema in (61) is correct, then the Habitual aspect marker has two requirements: that it be within the scope of PRESENT tense (thus locating UT within AST), and that AST contain the ET. Thus, why are the following configurations (in which AST contains a single ET that either follows or precedes UT) disallowed?

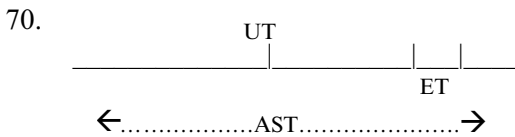
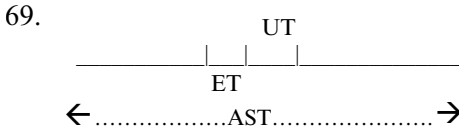

A possible answer to this is that the function of AST in these constructions is vacuous: the reason AST contains ET (and UT) in its grammatical usages is to express the idea that the state of affairs under discussion is ongoing, and has extended from the past through the present, and will likely continue into the future. In the configurations above, however, AST fails to serve this purpose. Rather, it results in the expression of the idea that there is a single bounded event happening within a period of time containing the UT, but says nothing about the temporal relation of UT to ET. This is uninformative, and thus disallowed.

Suggestive evidence for this comes from Yatzatchi Zapotec (YZ), which lacks a Habitual aspect morpheme. Rather, YZ verbs in sentences expressing habitual states or events appear with both a Progressive aspect marker and a marker indicating repeated actions:

71. Ch-ez-se|\_ ʼbo'on  
 prog-rep-order-3sF-3s  
 “He orders it again and again” (Butler 1980)

Assuming D&U’s definition of Progressive aspect as a spatiotemporal predicate locating ASP within ET, then YZ habitual constructions can be seen as highlighting points of time within a series of repeated events. Thus, in YZ, the need for an event to be repeated in order for it to be interpreted as habitual is directly reflected in the verbal morphology.

It is conceivable that the SLQZ Habitual aspect marker *r-* is derived from a multimorphemic habitual construction such as that used in YZ. The fact that the Habitual aspect marker in SLQZ is the only aspect marker with only one allomorph supports the possibility that it may be a derived, more recent form. Also, SLQZ lacks the “secondary aspect marker” YZ uses to express repetition. Perhaps the loss of this marker resulted in the re-interpretation of AST in habitual events from highlighting intervals of time

within repeated events to highlighting intervals of times containing an unspecified number of events.

### ***Present Perfect Use of the Habitual Marker***

The present perfect readings of Habitual-marked stative verbs can also be derived from the above constraints:

72. A g-uhc tsèi'ny wbihz r-ahcx:ùu'w Gye'eihlly  
 top perf-be fifteen day hab-sick Mike  
 "Mike has been sick for fifteen days"

Present perfect readings only result in this context in SLQZ when the starting point of the state is explicitly given. Furthermore, the "beginning points" of present perfect events in SLQZ are always introduced with a Perfective copula, as seen above. This gives rise to a configuration nearly identical to that in the Habitual under PAST construction seen in (59). Since the Habitual marker is a PAI, Habitual marked clauses must raise out of the scope of the Perfective (PAST-containing) clause in order to be licit. However, they must also reconstruct back into the scope of the PAST clause, where they are generated, at LF. This gives rise to a double-access reading: Mike's sickness is interpreted as simultaneous with both the past time denoted by the adverbial clause (that is, he was sick fifteen days ago), and the UT (Mike is still sick now). This gives the desired reading: Mike's sickness is simultaneous with the present time as well with a point in time fifteen days ago. Since sickness is interpreted as a state rather than a telic event, Mike's sickness is thus interpreted as continuous: it spans from the beginning point fifteen days ago to the present time.

The aspectual features of the Habitual marker support this analysis as well. Just as PRESENT tense is interpreted relative to two RTs (UT and the past time fifteen days ago), HABITUAL aspect establishes a containment relation between AST and two event times: the past time of sickness and the present time of sickness. This results in a reading in which the two ASTs overlap and are interpreted as denoting a single interval of sickness.

Habitual marked verbs are also used in another "non-habitual" context as well: when verbs that may appear with Neutral aspect, the other stative aspect in SLQZ, appear with Habitual aspect, they are interpreted as eventive, rather than stative:

73. Yra'ta gwèelchih r-zêiny-a', ø-zùub zhye'eht loh mee's  
 all time when hab-arrive-1s neut-sit cat on table  
 "Whenever I arrive, the cat is seated on the table"

74. Yra'ta gwèlchih r-zêiny-a', r-zùub zhye'eht loh mee's  
 all time when hab-arrive-1s hab-sit cat on table  
 “Whenever I arrive, the cat sits on the table”

In the first case, with Neutral aspect on “sit”, the cat is already in a seated state when the speaker arrives. In the second example, with Habitual aspect, the sitting is interpreted as an action rather than a state: the cat jumps on the table and sits down as the speaker enters, for instance.

I will return to this usage of Habitual aspect in the discussion of the Neutral aspect, marker, a stative marker with a more restricted and marked usage.

## 6.7 “Pure” Aspect Markers in SLQZ

In the previous sections, I showed evidence that the Habitual and Perfective aspect markers in SLQZ are dependent on the presence of PRESENT and PAST tense, respectively. While I argue that Tense is inherently present in all SLQZ sentences, it is not the case that all SLQZ aspect markers are specifically sensitive to tense selection restrictions. In the following sections, I briefly discuss the distribution and interpretation of two purely aspectual markers: the Progressive marker and the Neutral marker.

### 6.7.1 Progressive Aspect

As previously seen, the Progressive marker can have present, past, or future readings in matrix clauses:

75. Ca-bee'z-a' liu'  
 prog-wait-1s you  
 “I am/was/will be waiting for you”

When embedded under past clauses, it can have either a double-access-like or simultaneous reading, depending on context:

76. Nài ø-nnaa Gye'eihlly cay-ahcx:ùu'w Li'eb  
 yesterday neut-say Mike prog-sick Felipe  
 “Yesterday, Mike said Felipe is sick”  
 [F. was sick at both time of saying and UT]
77. Nài ø-nnaa Gye'eihlly cay-uàll Li'eb  
 yesterday neut-say Mike prog-sing Felipe  
 “Yesterday, Mike said Felipe was singing”  
 [F. was singing at time of saying, not at UT]

The fact that the apparent double-access reading in (76) is not required for all Progressive-under-past constructions suggests that Progressive marking is not a PAI. The different possible interpretations of the above sentences are probably determined by pragmatic factors: it is plausible for someone to be sick for a period of several days, but not for someone to be singing continuously for several days.

Similar effects result when Progressive verbs appear in complements of Irrealis verbs:

78. Li'eb ca-yùall y-nnii Gye'eihlly yzh:ii  
 Felipe prog-sing irr-say Mike tomorrow  
 "Tomorrow, Mike will say Felipe is singing"  
 [F. will be singing at time of saying]
79. Cay-ahcx:ùu'w Li'eb y-nnii Gye'eihlly yzh:ii  
 prog-sick Felipe irr-say Mike tomorrow  
 "Tomorrow, Mike will say Felipe is sick"  
 [F. sick now, will be sick tomorrow]

As in the Progressive under PAST cases, "singing" under Irrealis is interpreted as future-shifted (future progressive) while "being sick" under Irrealis is interpreted with a double-access interpretation (Felipe will be sick at the time of saying (tomorrow), and is sick now as well). This seems to occur whether or not the Progressive complement is fronted.

The Progressive marker is neither a PAI nor a PPI. Thus, it has neither inherent PRESENT or PAST readings, and may be controlled by PRESENT, PAST, or FUTURE tense. Unlike the Habitual marker and Perfective markers, the Progressive marker is purely aspectual, and may appear with any tense. The presence of a covert TENSE head, either in its own clause or in a clause taking the Progressive-marked verb as its complement, contributes to the realization of present, past or future progressive readings.

### ***Defining PROGRESSIVE Aspect***

I will follow Demirdache and Uribe-Extebarria's definition of PROGRESSIVE aspect as "a spatio-temporal predicate with the meaning of (with)in: it orders the AST within the event time". This definition is consistent with the behavior of Progressive-marked verbs in SLQZ.

In past progressive constructions, PAST tense orders UT after AST. PROG locates AST within the time of the event (between  $t_1$ , the time the event begins, and  $t_2$ , the time the event ends, in the timeline below):



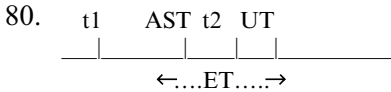

Future progressives are derived similarly: FUTURE tense orders UT before AST, which is located inside the event time:

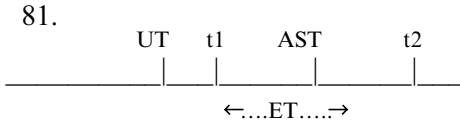

SLQZ also allows certain stative predicates that can receive stage-level interpretations to appear in the progressive:

82. Ca-cye'tlââ'z Li'eb  
 prog-be.happy Felipe  
 “Felipe is happy” (right now)

Such constructions are consistent with the definition of PROGRESSIVE given above because they denote temporary (temporally bounded) states: AST may pick out a time between the two temporal endpoints of the state. Crucially, stative constructions with Progressive-marked verbs do not receive habitual interpretations.

This is also consistent with the behavior of Progressive marking of statives in English: only predicates that can denote temporary states may appear with Progressive morphology, and like their SLQZ counterparts, can only refer to states occurring during a single interval of time, rather than habitual states of being:

83. Glenn is being silly  
 84. \*Glenn is being bald

### 6.7.2 The Neutral Aspect Marker

The Neutral aspect marker is lexically selected by a small number of locational and stative predicates. Like the Progressive marker, it may be used to express past, present, or future states:

85. ø-zùub zhye'eht loh mee's chih b-zêiny-a'  
 neut-sit cat on table when perf-arrive-1s  
 “The cat was seated on the table when I arrived”

86.  $\emptyset$ -zùub zhye'eht loh mee's chih y-zêiny-a'  
 neut-sit cat on table when irr-arrive-1s  
 "The cat will be seated on the table when I arrive"

When embedded under Past-interpreted matrix clauses, it receives a double-access reading similar to that of Habitual complements of past matrix clauses: the complement clause event is interpreted as simultaneous with both the matrix clause past event time (the time of saying) and the matrix clause utterance time:

87. Ldùu'ah n-u'uh Li'eb  $\emptyset$ -nnaa Gye'eihlly nài'  
 Oaxaca neut-exist Felipe neut-say Mike yesterday  
 "Mike said yesterday that Felipe is in Oaxaca"
88. Nài'  $\emptyset$ -nnaa Gye'eihlly Ldùu'ah n-u'uh Li'eb  
 yesterday neut-say Mike Oaxaca neut-exist Felipe  
 "Mike said yesterday that Felipe is in Oaxaca"

These sentences can only be interpreted to mean that Felipe is still in Oaxaca at the time the sentence is spoken; they cannot mean that Felipe had been in Oaxaca yesterday and is back now.

Like the Habitual marker, the Neutral marker may also be used on verbs with present perfect readings:

89. A g-uhc tyo'p iihahz n-u'uh Gye'eihlly Ldùu'ah  
 top perf-be two year neut-exist Mike Oaxaca  
 "Mike has lived in Oaxaca for two years"

The Neutral marker is predominantly used to express states, rather than actions. In examples (85-86), the cat can only be interpreted as being seated before, during, and after the time of the speaker arriving. In contrast, the Habitual, Progressive, Perfective, or Definite aspect markers would be used to express the actual act of the cat sitting:

90. Yra'ta gwèel chih r-zêiny-a' r-zùub zhye'eht loh mee's  
 all time when hab-arrive-1s hab-sit cat on table  
 "Every time I arrive, the cat sits on the table"
91. Chih b-zêiny-a' ca-zùub zhye'eht loh mee's  
 when perf-arrive-1s prog-sit cat on table  
 "When I arrived the cat was sitting (seating herself)  
 on the table"

92. Chih b-zēiny-a’ b-zùub zhyee’t loh mee’s  
 when perf-arrive-1s perf-sit cat on table  
 “When I arrived, the cat sat on the table”

It seems to be that all verbs (with the exception of the reduced copula *nàa*) that allow Neutral aspect marking also have Habitual forms with telic, inchoative readings. The converse, however, is not the case.

A possible exception to this is the case of *nmaa* “say”. A plausible explanation for this is that *nmaa* is not interpreted as an eventive verb (like “utter”) but as a verb reflecting belief (much like English “assert”). Suggestive evidence for this idea comes from the fact that use of *nmaa* is dispreferred in contexts in which the speech act itself is emphasized:

93. Chonn gwèell w-nii/?ø-nnaa Gye’eihlly  
 three times perf-say/?neut-say Mike  
 “Mike said three times

r-zeeblàaa’z Gye’eihlly Lia Oliieb.  
 hab- like Mike Ms. Olivia  
 that he likes Olivia”

### ***The Tense and Aspect Features of the Neutral Marker***

The Neutral marker shows conflicting evidence for the presence of tense. On one hand, Neutral verbs in the complements of past-interpreted clauses, like Habitual verbs, receive double-access readings (as seen in (87) and (88)), which suggests the Neutral marker is a PAI, and needs to be licensed by PRESENT tense. The potential PAI status of the Neutral marker is further supported by its use in present perfect constructions. Like Habitual-marked verbs, Neutral-marked verbs may receive present perfect readings in the presence of a time expression introduced by a past copula. The present perfect reading for Habitual verbs in this context was analyzed as a double-access reading resulting from the need for the Habitual verb to raise out of the scope of the past-interpreted verb introducing the time expression. The use of the Neutral aspect in this context suggests that the Neutral marker, like the Habitual marker, is a PAI that must move out of the scope of the past copula.

The Neutral marker, however, also appears in contexts incompatible with its potential PAI status. As seen in (94), repeated below, clauses with Neutral-marked verbs may be used to express past states:

94. ø-zùub zhye’eht loh mee’s chih b-zēiny-a’.  
 neut-sit cat on table when perf-arrive-1s  
 “The cat was seated on the table when I arrived”

This sentence is interpreted to mean that the cat was already seated at the time of the speaker’s arrival. It does not necessarily mean, however, that the cat is still seated at the time the sentence was spoken (although this

reading may be pragmatically possible). Thus, this sentence cannot be treated as a “double-access” case, as can (87). If the Neutral marker were indeed a PAI, this double-access reading would be required, and past readings such as that in (94) would be impossible.

The possibility I will consider is that the Neutral marker, like the Progressive marker, is in fact a solely aspectual marker rather than a reflex of PRESENT or PAST tense. The apparent double-access readings that arise when Neutral clauses are embedded under certain past-interpreted clauses result from the aspectual features, rather than tense features, of the Neutral marker.

The first hint as to why apparent double-access readings result is the fact that the Neutral marker (with the possible exception of “say”) only appears on atelic, stative predicates. Because these stative predicates have no inherent endpoints, a state that is said to have held in the past can be naturally interpreted as still holding in the present. Pragmatic factors can affect this interpretation, however, as seen by the possible readings of (94).

This raises the question of what factors in the semantics of the Neutral marker restrict it to stative and locational predicates. In other words, how does it differ from the Habitual marker in expressing ongoing states/events?

A potential hint comes from Stubblefield and Stubblefield’s (1991) analysis of an analogous form in Mitla Zapotec (MZ): they treat the *na*-prefix on stative predicates in MZ (cognate to the SLQZ Neutral form) as a marker of “stative mood” that “replaces aspectual prefixes” (p. 225). They also gloss stative predicates with *na*-prefixes as “is-V” or “be-V”:

95. Golgisah-re gideb jeh na-ga-sah-ni ro? te biliää  
 Golgisah-this all day is-lying-back-his mouth one cave  
 “This Golgisah spent all his time lying in the entrance of a cave”  
 (Mitla Zapotec: Stubblefield and Stubblefield 1994, p. 5)

An earlier analysis of MZ (Briggs 1961) likewise treats the *na*- prefix on stative predicates as a reduced copula, rather than a separate stative aspectual form corresponding to the SLQZ Neutral aspect.

A similar account may hold for the SLQZ Neutral marker. Suggestive evidence for this comes from the behavior of the reduced copula *nàa* “be”, the only verb that takes only Neutral marking. The absence of a Habitual form for *nàa* “be” (and its limited morphology—it cannot cooccur with pronominal subject agreement markers, nor can it appear with other aspect markers) makes it a likely historical source for the Neutral marker. If the Neutral aspect marker in SLQZ is indeed derived from a reduced copula, this would account for its limited distribution: it historically only appeared with adjectival and nominal (that is, stative) predicates, and this is still reflected in its current usage.

The origin of the Neutral marker as a copula may also be reflected in its aspectual features. A standard function of a copula is to establish an iden-

tivity relation between an entity and a state. Under D&U’s account, aspect serves to establish a spatio-temporal relationship between a highlighted period of time (AST, the assertion time) and an event time. If the Neutral marker is a copula reanalyzed as an aspect marker, then the Neutral aspect can be defined as a spatiotemporal predicate establishing an identity relation between AST and ET. Thus  $AST=ET$ . Since the Neutral marker only appears on stative, atelic predicates, the event time is simply the period of time during which the state holds. This results in the Neutral marker reflecting an identity relation between AST and a state. Thus, the Neutral marker expresses the existence of an ongoing state.

The Neutral aspect, then, differs from the Habitual aspect in several ways. While both can be used to express the existence of ongoing states, the Neutral aspect cannot be used to express non-continuous (repeated) events or states. Recall that Habitual-marked verbs may denote repeated actions and events because HAB marks AST as containing an event time or set of event times. Since NEUTRAL aspect, in contrast, marks an identity relation between AST and ET, a single AST cannot describe more than one event or state. Also, while the Habitual marker is necessarily licensed by PRESENT tense and may not remain within the scope of PAST, the Neutral marker has no tense features of its own, and thus may be used to express past, present, or future events.

This brings us back to the eventive use of the Habitual aspect on certain stative predicates: as seen in (90), repeated below, when the Habitual aspect is used with predicates that allow use of the Neutral aspect, the predicate receives an eventive, rather than stative, reading:

96. Yra’ta gwèel chih r-zëiny-a’  
 all time when hab-arrive-1s  
 “Every time I arrive,  
  
 r-zùub zhye’eht loh mee’s  
 hab-sit cat on table  
 the cat sits on the table”
97. Yra’ta gwèel chih r-zëiny-a’ ø-zùub zhye’eht loh mee’s  
 all time when hab-arrive-1s neut-sit cat on table  
 “Every time I arrive, the cat is seated on the table”

This contrast can also be attributed to the different relations between AST and ET expressed by the Habitual and Neutral aspects. While the Habitual marker may theoretically be used to express both the stative and eventive readings of “sit”, the Neutral marker may only express the stative meaning. Since the Neutral marker is available to express the stative meaning and languages disprefer having more than one inflectional form for identical meanings, the Habitual marker on predicates that may appear with the Neutral marker, by default, expresses the non-stative, eventive reading available to the verb.

## 6.8 The Temporal Interpretation of the Modal Aspects

The remaining three aspect markers in SLQZ—the Irrealis, Subjunctive, and Definite—encode modal, as well as temporal information. Thus, there are contexts in which their distribution and possible interpretation is more constrained than that of the other aspect markers.

I begin this section with a discussion of the Irrealis aspect marker, since this marker shows a clear contrast between its modal and purely temporal uses. I will show that in its modal usage, the distribution and interpretation of the Irrealis marker correspond closely to the distribution of subjunctive mood in Romance and other languages. I will also show that a potential conflict between the mood and tense licensing requirements of some Irrealis clauses provides more evidence that some complement clauses in some tense configurations must raise for anti-polarity reasons. I then discuss the Subjunctive aspect marker, which I will show to be a past-tense counterpart to the Irrealis marker. Finally, I discuss the Definite aspect, which has the apparently puzzling feature of being able to express both emphatic future events, as well as some past events.

### 6.8.1 The Irrealis “Aspect”

Like the other modal aspect markers, the Irrealis marker allows both modal and non-modal readings of the verbs it modifies. On its non-modal reading, the Irrealis marker is used to describe future events:<sup>4</sup>

98. Y-tò'oh Gye'eihlly ca'rr  
 irr-sell Mike car  
 “Mike will sell the car”

On its modal reading (that is, in the complement of modal and intensional verbs) it has a subjunctive-like reading:

99. R-càa'z y-tò'oh Gye'eihlly ca'rr  
 hab-want irr-sell Mike car  
 “Mike wants to sell the car”

100. N-àa pahr y-tò'oh Gye'eihlly ca'rr  
 neut-be for irr-sell Mike car  
 “Mike has to sell the car”

<sup>4</sup> Much previous literature on tense and modality lists has treated expressions of future events as expressions of modality, rather than expressions of tense. For reasons to be made explicit later, I will call the usage of Irrealis aspect in (99) “non-modal,” and analyse it as a pure expression of tense and aspect.

101. Z-àa'lle'eh g-ùuny bùunny nadaar rèè'  
 def-allow irr-do person swim here  
 "Swimming is allowed here"

I will discuss these two different usages in turn, then propose a structure that accounts for both uses of the Irrealis marker in a unified fashion.

### **Non-Modal Irrealis Constructions**

The non-modal reading of Irrealis-marked verbs occurs obligatorily when Irrealis verbs appear in matrix clauses, as seen in (98), repeated from above:

102. Y-tò'o'h Gye'eihlly ca'r.  
 irr-sell Mike car  
 "Mike will sell the car"

In (102), the verb "sell" refers to an event assumed to take place at a later time in the actual world containing Mike and the speaker. The proposition of Mike selling the car at a later time is presumed to be a real event in the real world: the speaker would not have uttered this sentence if she or he did not believe it would be true that Mike would sell his car. I have thus labelled this reading "non-modal" because the future event described is assumed to be anchored in the actual world of the speaker.

When embedded under past-interpreted matrix verbs, Irrealis verbs may be interpreted as expressing future tense with regard to the matrix clause event time, or future tense with regard to the matrix clause utterance time, depending on whether or not the complement clause is embedded under the matrix clause in the overt syntax:

103. Nài' ø-nnaa Gyeeihly g-wà'Il Li'eb  
 yesterday neut-say Mike irr-sing Felipe  
 "Yesterday, Mike said Felipe would sing"  
 [F.sings after "saying", either before or after UT]
104. G-wà'Il Li'eb ø-nnaa Gye'eihlly nài  
 irr-sing Felipe neut-say Mike yesterday  
 "Mike said yesterday Felipe will sing"  
 [F. can only be interpreted as singing after UT]

Irrealis-marked verbs embedded under other Irrealis-marked verbs receive future-shifted, rather than simultaneous, readings:

105. Yzh:ii y-nii Gye'eihlly g-ahcx:ùu'w Li'eb  
 tomorrow irr-say Mike irr-sick Mike  
 "Tomorrow, Mike will say Felipe will be sick"  
 [F. can only be sick after Mike says so, not at the same time]

Non-modal Irrealis, then, seems to show Tense features as well. When embedded under a past-interpreted clause, Irrealis can be interpreted as ordered after the event time of the matrix clause. When fronted, it can only be interpreted as ordered after the matrix clause utterance time, since it is out of the governing range of the matrix clause.

### **Modal Irrealis Constructions**

When embedded under modal and intensional verbs, Irrealis-marked verbs receive a slightly different interpretation and are subject to additional constraints on movement and temporal interpretation. These constraints will prove to be a useful diagnostic for the tense and aspect features of the Irrealis marker.

Repeated below are some examples of Irrealis verbs with modal interpretations:

106. R-càa'z y-t òò'oh Gye'eihlly ca'rr  
 hab-want irr-sell Mike car  
 "Mike wants to sell the car"
107. N-àa pahr y-tòò'oh Gye'eihlly ca'rr  
 neut-be for irr-sell Mike car  
 "Mike has to sell the car"
108. Z-àa'lle'eh g-ùuny bùunny nadaar rèè'  
 def-allow irr-do person swim here  
 "Swimming is allowed here"

In contrast to the non-modal Irrealis examples, the Irrealis-marked verbs here describe not actual events assumed to take place at some future time, but only potential events that may or may not take place. A speaker uttering (99), for instance, makes no claim about whether or not Mike will actually sell the car.

This use of the Irrealis aspect syntactically and semantically resembles subjunctive constructions in Romance (and other) languages. The class of verbs that subcategorizes Irrealis complements in SLQZ closely parallels the class of verbs that subcategorize subjunctive complements in other languages. Farkas (1992a and 1992b) notes that predicates requiring subjunctive complements in Hungarian, Romanian, and French fall into four classes: directives (such as "tell"), desideratives (e.g., "want"), deontics (e.g. "must"), and epistemics "expressing remote possibility" (Farkas 1992a, p. 208) or "expressing neutral/negative commitment" (Farkas 1992b, p. 73) (such as "be impossible" and "doubt"). These classes of predicates likewise require Irrealis complements in SLQZ:

109. R-e'ihpy-a' Gye'eihlly y-tòò'oh ca'rr  
 hab-tell-1s Mike irr-sell car  
 "I told Mike to sell the car" (directive)



110. R-càa'z-a' y-tò'oh Gye'eihlly ca'rr  
 hab-want-1s irr-sell Mike car  
 "I want Mike to sell the car" (desiderative)
111. N-àa pahr y-tò'oh Gye'eihlly ca'rr  
 neut-be for irr-sell Mike car  
 "Mike has to sell the car" (deontic)
112. Cë'ity r-liuw-dya' y-tò'oh Gye'eihlly ca'rr.  
 neg hab-be.likely-dya' irr-sell Mike car  
 "Mike is unlikely to sell the car" (negative commitment)

Furthermore, the interpretation of Irrealis verbs in these contexts is identical to that posited for subjunctive clauses. The semantic function of subjunctive clauses can be most clearly seen when contrasted with that of indicative clauses.

Farkas (1992a and 199b) defines the difference between contexts that introduce subjunctive clauses in Romance and Hungarian and those that introduce indicative complements in terms of possible world semantics. Indicative clauses, in her terms, introduce propositions that are assumed to be true in the actual world inhabited by the speaker and listeners. In (113), for instance, the complement of "say", "has left", appears in indicative mood:

113. Ion a spus ca Maria a plecat  
 Ion has said that Maria has left  
 (Romanian: Farkas 1992b, p. 70)

Here, the speaker is reporting Ion's assertion (assumed to be true) that Maria has left. Because such propositions are assumed to be true in one specific world, they are considered to exist in a "modally specific environment" (Farkas 1992a, p. 214).

Subjunctive clauses, in contrast, denote not actual events in the real world, but only potential events:

114. Necessito que m'ajudis  
 need.1sg that me-help.sub.pres.2sg  
 "I need you to help me" (Catalan: Quer 1998, p. 43)

This is the same function served by modal Irrealis complements in (109-112).

The contexts in which propositions expressed with subjunctives appear are, in Farkas' terms, "modally non-specific" (Farkas 1992a, p. 215): that is, they are not assumed to be true in any specific world (such as the actual world of the speaker), but only in a set of possible worlds.

The two uses of Irrealis-marked verbs, then, can be distinguished in terms of modal specificity and non-specificity. As previously noted, Irrealis verbs used to describe future events in examples such as (98) assume the eventual occurrence of such an event in the actual world. Thus, they introduce propositions into modally specific environments. Because their interpretation is constrained to the actual world, I have called such uses of the Irrealis “non-modal”.

In contrast, the propositions expressed by Irrealis-marked clauses in (109-112) clearly appear in modally non-specific contexts. Because their truth value is not fixed in the actual world, I have labelled such uses of the Irrealis as “modal”.

A second parallel between modal Irrealis constructions and subjunctive constructions is their distribution in sentences with more than one embedded clause. Quer (1998) notes that subjunctive mood is only marked on immediately embedded complements of intensional predicates: if more than one clause is embedded under a subjunctive-triggering matrix predicate, only the first of the embedded clauses appears with subjunctive marking. He gives the following example (among others) from Catalan:

115. Vull [que creguin [que ens agrada]]  
 want.1SG that believe.SUB.3PL that us please.IND.3SG  
 “I want them to believe that we like it” (Quer 1998, p. 36)

Here, only the immediate complement of “want” appears with subjunctive marking.

The same constraint holds in SLQZ:

116. R-càa’z Gye’eihlly y-nnii Gye’eihlly doctoor n-àa Gye’eihlly  
 hab-want Mike irr-say Mike doctoor neut-be Mike  
 “Mike wants to say that he is a doctor”

Here, the Irrealis marker only appears on the first verb embedded under the intensional predicate “want” (“say”). A non-modal aspect marker, the Neutral marker, appears on the complement of “say”.

A third parallel between modal Irrealis and subjunctive constructions is suggested by the fact that Irrealis complements of intensional verbs and modals cannot be preposed:

117. \*Y-tòò’oh Gye’eihlly ca’rr n-àa pahr  
 irr-sell Mike car neut-be for  
 “Mike has to sell the car”
118. \*G-ùuny bùunny nadaar rèe’ z-àa’lle’eh  
 irr-do person swim here def-allow  
 “Swimming is allowed here”

This suggests that Irrealis complements with modal readings must remain under the scope of the matrix predicates that select them. This is analogous to the scopal requirements of Italian subjunctive clauses noted

by Brugger and D'Angelo (1994): they note that intensional verbs such as *desiderare* “want” may take either subjunctive or indicative verbs as complements. However, indefinite nominals in the complements of intensional verbs receive different scope readings depending on whether or not they appear in subjunctive or indicative clauses (examples from Brugger and D'Angelo 1994, p. 12):

119. Gina desidera sposare un uomo che è ricco  
 “Gina wants (to) marry a man who is (Ind.) rich”  
 E(x) [rich-man](x) Gina wants [Gina marries x]
120. Gina desidera sposare un uomo che sia ricco  
 “Gina wants (to) marry a man who is (subj.) rich”  
 Gina wants [E(x) [rich-man](x) & Gina marries x]

Thus, indefinites in indicative complements of Italian intensional verbs obligatorily receive wide-scope readings (in (119), Gina has a specific rich man in mind) while indefinites in subjunctive clauses under intensional verbs only receive narrow-scope readings (in (120), Gina wants a rich man to exist for her to marry, but does not assert the existence of such an individual).

Brugger and D'Angelo account for this asymmetry as follows: They assume that predicates that allow subjunctive complements contain an intensional operator, located in the head of the predicate (that is, in V). Subjunctive verbs are polarity items that must remain within the scope of this operator. Indicative verbs, on the other hand, are “Anti-Intensional-Operator Polarity Items” that cannot appear within the scope of intensional operators. Thus, indefinites in subjunctive complements of intensional verbs necessarily receive narrow scope because the subjunctive clause cannot raise out of the scope of the matrix clause intensional operator. Conversely, indicative complements of intensional verbs must raise out of the scope of the matrix intensional operator, so any indefinite that appears in such a complement will receive a wide-scope reading.

If this account is correct, it likewise explains the inability of Irrealis-marked verbs in SLQZ to be raised out of intensional matrix clauses: Irrealis verbs with modal readings are a reflex of subjunctive mood, and thus are expected to be subject to the same syntactic and semantic constraints as subjunctives crosslinguistically.

### **More on the Distribution of Modal Irrealis Verbs**

Modal Irrealis verbs most commonly appear as complements of Habitual and Neutral-marked intensional predicates:

121. R-cààa'z Gye'eihlly g-ahcnèe dannuan  
 hab-want Mike irr-help us  
 "Mike wants to help us"

122. N-àa pahr y-tòò'oh Gye'eihlly ca'rr  
 neut-be for irr-sell Mike car  
 "Mike has to sell the car"

They may also appear as complements of Progressive-marked predicates, including those with past or future progressive meanings :

123. Cay-e'ihpy Lia Oliieb Li'eb y-gyàa' Li'eb  
 prog-ask Ms. Olivia Felipe irr-dance Felipe  
 "Olivia is asking Felipe to dance"

124. Cay-e'ihpy Lia Oliieb Li'eb y-gyàa'  
 prog-ask Ms. Olivia Felipe irr-dance  
 "Olivia was asking Felipe to dance"

Li'eb chih b-zèihny Gye'eihlly  
 Felipe when perf-arrive Mike  
 when Mike arrived"

125. A cay-e'ihpy Lia Oliieb Li'eb y-gyàa' Li'eb  
 top prog-ask Ms. Olivia Felipe irr-dance Felipe  
 "Olivia will be asking Felipe to dance"

chih y-zèihny-a'  
 when irr-arrive-1s  
 when I arrive"

Modal Irrealis verbs may also appear under Perfective-marked matrix predicates. They may only do so, however, when interpreted as referring to potential events in the future with regard to UT, rather than potential events ordered in the future with regard to the past ET:

126. \*Guhclààa'z Gye'eihlly g-ahcnèe dannuan  
 perf-want Mike irr-help us  
 "Mike wanted to help us"

127. Nài' g-uhclààa'z-a' lààa' Gye'eihlly gw-ùall  
 yesterday irr-want-1s foc Mike irr-sing  
 "Yesterday, I wanted Mike to sing  
 lohoh laanìh nih g-ahc stux:maan  
 at party REL irr-be next.week  
 at the party next week"

Complements of Perfective intensional verbs appear with the Subjunctive aspect marker when referring to potential events in the past:

128. Guhclàaa'z Gye'eihlly ny-ahcnèe dannuan  
 perf-want Mike subj-help us  
 "Mike wanted to help us"

The Subjunctive aspect will be discussed in Section 7.3.

### ***The Syntactic Representation of Mood***

This raises the question of how modal and non-modal Irrealis verbs are distinguished syntactically: that is, why can't Irrealis-marked verbs in matrix clauses receive modal readings, and what blocks Irrealis-marked complements of intensional verbs from receiving non-modal readings?

The difference is the presence or absence of syntactic and semantic Mood. Assuming Brugger and D'Angelo's account is correct, the expression of subjunctive mood requires the presence of both a subjunctive operator (provided by an intensional predicate) and subjunctive mood itself in the embedded clause.

I will thus assume that Irrealis verbs with modal readings raise into the pre-TP MoodP projection, while Irrealis verbs with non-modal readings do not. Modal readings of matrix clause Irrealis verbs are blocked because there would be no licensing operator available for subjunctive mood.

Evidence for movement of modal Irrealis verbs into MoodP comes from the obligatory modal reading of Irrealis verbs under ordinary clausal negation. This can be seen in the contrast between two possible negated Irrealis complements of *rei'ihpy* "tell". SLQZ *re'ihpy* may be used either as a declarative (introducing an indicative complement) or a directive (introducing a subjunctive complement):

129. R-e'ihpy Pa'amm laarëng  
 hab-tell Pam 3p.prox  
 "Pam told them"

cë'ity-dya-rëng g-ù'all-rëng li'ebr yzhii  
 neg-dya'-3p.prox irr-read-3p-book tomorrow  
 they will not read the book tomorrow"

130. R-e'ihpy Pa'amm laarëng cë'ity g-ù'all-dya'-rëng li'ebr  
 hab-tell Pam 3p neg irr-read-dya'-3p book  
 "Pam told them not to read the book"

Recall from Chapters 3 and 4 that in normal clausal negation, the negative quantifier *cë'ity* precedes, and the variable *dya'* follows, the verb. As was noted in Chapter 3, however, this structure is disallowed with Irrealis verbs with non-modal interpretations, and the alternate negation structure that appears in (129) is used instead.

Under normal clausal negation, Irrealis verbs obligatorily get modal readings. Such a reading is seen in the complement clause of (130), where the matrix clause verb *re'ihpy* “tell” is used as a directive. This was accounted for in Chapter 4 in the following way: movement of a negated VP out of TP into NegP passes through MoodP. When MoodP is inactive (as in the case of the non-modal aspects) such movement has no interpretive effect. Since Irrealis verbs may trigger Mood, however, movement of an Irrealis verb through MoodP forces a modal reading. The non-modal reading of the negated Irrealis verb in (129) is preserved by embedding the Irrealis verb under a covert existential verb that itself undergoes negation.

### 6.8.2 The Tense and Aspect Features of Irrealis Aspect

Now I turn to the formal definition of the tense and aspectual features of the Irrealis aspect. As seen in the preceding discussion, Irrealis aspect is used to describe potential events or states. On its non-modal usage, Irrealis aspect describes acts the speaker assumes will take place in the actual world. On its modal usage, it describes potential acts in sets of alternate worlds.

Thus, the Irrealis aspect in both its modal and non-modal functions highlights intervals of time before the initiation of an event. I will thus define IRR aspect as ordering AST before ET:

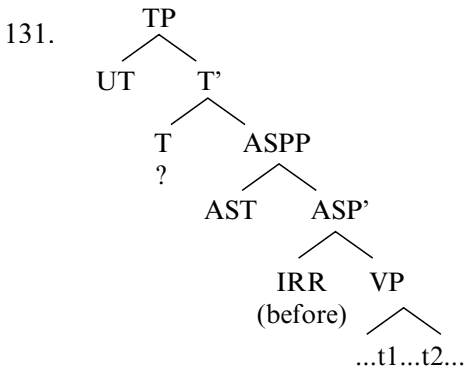

This leaves the question of the definition of tense features for Irrealis aspect. This issue is complicated by the fact that modal and non-modal Irrealis verbs show different ranges of temporal interpretation. Non-modal Irrealis verbs embedded under past-interpreted matrix clauses, for instance, may describe events ordered in the future after the matrix clause past ET but before UT ((132), repeated from above), while modal Irrealis verbs under past-interpreted matrix clauses may not (133):

132. Nài' ø-nnaa Gyeeihly g-wà'u'll Li'eb  
 yesterday neut-say Mike irr-sing Felipe  
 “Yesterday, Mike said Felipe would sing”  
 [F.sings after “saying”, either before or after UT]

133. Nàì' g-uhclààa'z-a' lààa' Gye'eihlly  
 yesterday perf-want-1s foc Mike  
 "Yesterday, I wanted Mike"

gw-ùall lohoh laanìh nih g-ahc stux:maan  
 irr-sing at party REL irr-be next.week  
 to sing at the party next week"

Up to now, I have tacitly assumed that the two uses of Irrealis aspect differ only in their modal features. However, data such as these suggest that they differ in their tense features as well. The possibility of past-shifted future readings in non-modal Irrealis complement clauses indicates that the complement clause tense may take the matrix clause ET as its external temporal argument, and thus may take scope under matrix clause PAST tense. Thus, the non-modal Irrealis marker is not a PAI. The fact that the non-modal Irrealis marker can appear outside the scope of PAST tense (and obviously, does not independently encode PAST) shows it is not a PPI, either. Thus, it encodes neither PRESENT nor PAST tense. I will show that the non-modal Irrealis marker encodes FUTURE tense.

Yet, identical readings are impossible with modal Irrealis complements of past-interpreted intensional predicates. Rather, a double-access reading results: in (133), Mike's singing is interpreted as possible, but not yet initiated both at the matrix clause past ET (yesterday) and at the matrix clause UT.

The obligatory double-access reading of modal Irrealis under PAST is reminiscent to that of Habitual under PAST. This suggests that the Irrealis marker in modal contexts, like the Habitual marker, is a PAI that must raise out of the syntactic scope of PAST at LF, and that the Irrealis marker in modal contexts, like the Habitual marker, must be licensed by PRESENT tense.

In short, the following generalization can be made:

134. The Irrealis marker is a PAI in modal contexts, but not in non-modal contexts.

I will thus assume that the full tense and aspect structure for modal Irrealis aspect is as follows:

- 135.

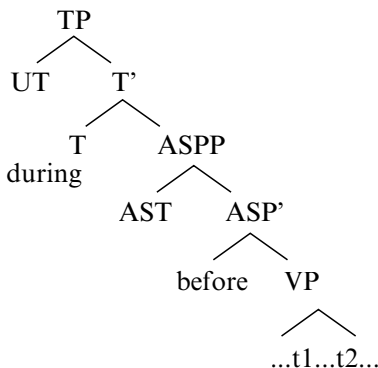

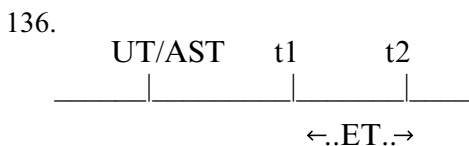
Modal Irrealis:

Interpretive evidence supports the idea of PRESENT tense in the structural representation of modal Irrealis aspect. Consider the following example:

137. Z-àa'le'eh g-ùuny bùunny nadaar rèè'  
 def-allow irr-do person swim here  
 "Swimming is allowed here"

This is most naturally interpreted to mean that swimming is possible now (even if nobody is actually swimming at UT). The modal verb allow, then, introduces possible worlds in the present time in which swimming is possible (though not yet carried out).

***Modal Irrealis under Past Constructions: Evidence for "Covert" Overt Movement***

The joint mood and tense requirements of modal Irrealis verbs, however, appear to have the potential to conflict with each other. On one hand, the Irrealis marker in modal contexts is an intensional polarity item that needs to be under the scope of an intensional predicate. On the other hand, it is a PAI that cannot remain under the syntactic scope of PAST tense. If both of these conditions hold true of modal Irrealis verbs, then sentences such as (133) should be illicit: if the modal Irrealis verb is a PAI and raises out of the scope of matrix PAST, it also raises (wrongly) out of the scope of the matrix intensional predicate. Indeed, Brugger and D'Angelo (1997) argue that present subjunctives are disallowed under past-tense intensional predicates in Italian for these very reasons—there is no way for the present subjunctive verb to be simultaneously under the scope of the matrix intensional predicate while outside the scope of matrix clause past tense:

138. \*Gino desiderava sposare una ragazza che sia ricca  
 Gino wanted to marry a girl who is (subj.) rich  
 (Brugger and D'Angelo 1997)



This also holds true when the complement of the past intensional predicate is not a relative clause (Filippo Beghelli, p.c.):

139. Non credetti che Maria fosse stupida  
 neg believe-past-1s that Maria be-past-subj. silly  
 “I didn’t believe Maria was silly”
140. \*Non credetti che Maria sia stupida  
 neg believe-past-1s that Maria be-pres-subj. silly  
 “I didn’t believe Maria is silly”

This raises two questions: first, what allows modal Irrealis verbs to appear under past matrix clauses in SLQZ, and second, if embedded Irrealis clauses are allowed to raise out of the matrix clause at LF (thus forcing their reading as future with regard to the matrix clause utterance time), what blocks them from raising overtly out of the scope of the matrix predicate?

There are two possible strategies that would allow modal Irrealis complements of Past matrix clauses. The first, and simpler, possibility is that the modal Irrealis complement raises at LF, and for whatever reason is blocked from raising overtly. Another possibility is that the Irrealis complement clause does raise overtly (141), then the matrix clause raises again past it (142):

141. [gw-ùall lohoh laanìh nih g-ahc stux:maan]<sub>i</sub>  
 [irr-sing at party REL irr-be next.week]<sub>i</sub>  
 [to sing at the party that will be next week]<sub>i</sub>
- [nài’ g-uhclààa’z-a’ lààa’ Gye’ eihlly t<sub>i</sub>]<sub>j</sub>  
 [yesterday perf-want-1s foc Mike t<sub>i</sub>]<sub>j</sub>  
 [yesterday I wanted Mike t<sub>i</sub>]<sub>j</sub>
142. [nài’ g-uhclààa’z-a’ lààa’ Gye’ eihlly t<sub>i</sub>]<sub>j</sub>  
 [yesterday perf-want-1s foc Mike t<sub>i</sub>]<sub>j</sub>  
 [yesterday I wanted Mike t<sub>i</sub>]<sub>j</sub>
- [gw-ùall lohoh laanìh nih g-ahc stux:maan]<sub>i</sub> t<sub>j</sub>  
 [irr-sing at party REL irr-be next.week]<sub>i</sub> t<sub>j</sub>  
 [to sing at the party that will be next week]<sub>i</sub> t<sub>j</sub>

This would allow the Irrealis clause to raise out of the scope of matrix PAST tense on one hand (141) while remaining under the scope of the matrix predicate on the other (142). That these conditions can be fulfilled in different stages of the derivation is consistent with observations earlier in this chapter about reconstruction: double-access readings were treated as the sum of the logical construals of LF and spell-out derivations.

Although this second option is more costly in terms of the number of movement operations involved, there is interpretive and structural evidence supporting it. Furthermore, the idea that constituents may undergo multiple movement operations that result in the same linear ordering is not unprecedented: Kayne (1997) proposes that a number of interpretive ambiguities in English negation constructions, for example, can better be accounted for by multiple instantiations of overt movement, rather than single operations of covert movement. Below, I present some of the evidence for overt raising of both the matrix and complement clauses in modal Irrealis under Past constructions in SLQZ.

Earlier in this chapter I proposed that proposed complement clauses raise to the focus projection of the higher clause. Thus, if all raising is overt in (133), the Irrealis complement clause raises to spec, FocP of the Perfective matrix clause (irrelevant projections omitted for clarity):

143.

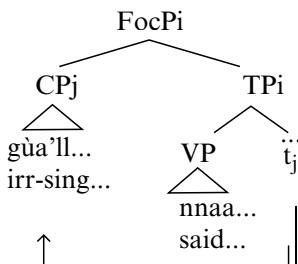

In (143), the Perfective clause (at least the part of it below FocP) raises and adjoins to the Irrealis clause. (Below, I assume this movement is to FocP of the Irrealis clause):

144.

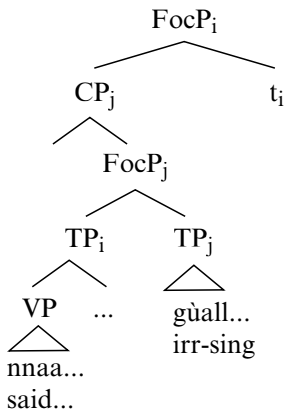

Thus, FocP in both the matrix and complement clause is filled. This would mean that constructions that require the availability of FocP in either the matrix or complement clause (such as *wh*-movement) would be blocked in structures such as (131).

This prediction is partially borne out. While *wh*-movement may take place out of modal Irrealis complements of Perfective matrix verbs, the resulting *wh*-question gets a different temporal interpretation from its non-interrogative counterpart. In brief, the Irrealis verb may not be interpreted as a PAI, and thus does not need to raise out of the scope of matrix clause PAST.

Consider, for example, the following sentences:

145. G-uhclààa'z Li'eb y-sëi'dy Gyeeihly  
 perf-want Felipe irr-study Mike  
 "Felipe wanted Mike to study"

pahr prweeb nih g-ahc stuxmaan  
 for test REL irr-be next.week  
 for the test next week"

This sentence means that Felipe wanted Mike to study for the test, but now either doesn't want Mike to study or no longer cares if he does. It is still possible in the context expressed by this sentence, however, that Mike will go ahead and study without Felipe's prodding. Thus, the Irrealis complement represents an incompleting event ordered in the future both with regard to the UT and the matrix past ET. This double-access reading indicates that the embedded clause raises out of the scope of matrix clause PAST tense at some point in the derivation: only such movement can account for the Irrealis verb taking UT as one of its external arguments. This is consistent with the PAI status of modal Irrealis verbs.

Now I compare (145) with its counterpart with a Subjunctive complement:

146. G-uhclààa'z Li'eb n-sëi'dy Gyeeihly  
 perf-want Felipe subj-study Mike  
 "Felipe wanted Mike to study"

pahr prweeb nih g-ahc stuxmaan.  
 for test REL irr-be next.week  
 for the test next week"

While this receives the same English translation as (145), it differs in meaning: it can only mean that Felipe wanted Mike to study, but Mike didn't study. In this case, the complement Subjunctive verb receives a counterfactual reading: it describes an incompleting event of studying in the

past: there is no possibility that the action may be fulfilled at some later time. In short, the Subjunctive aspect differs from the modal Irrealis in that it describes potential or incomplete events in the past, rather than in the future.

When a *wh*-question is formed from a modal Irrealis under Perfective sentence, however, the Irrealis verb receives an interpretation identical to that of a Subjunctive complement of a Perfective verb:

147. Tu g-uhclàaa'z-u' y-sëi'dy pahr prweeb nih g-ahc stuxmaan?  
 who perf-want-2s.inf. irr-study for test REL irr-be next.week  
 "Who did you want to study for the test next week?"

This can only mean "Which person did you want to study for the test, but didn't study for the test?" The complement clause thus receives the same kind of counterfactual reading as the subjunctive complement in (146). Despite the presence of the Irrealis marker in the complement, this sentence cannot have a meaning analogous to that of its non-interrogative counterpart, such as "Which person did you want to study for the test, but don't want to anymore?"

In short, *wh*-extraction from a modal Irrealis under Past construction somehow conflicts with the PAI interpretation of the modal Irrealis verb. While Irrealis complements may still appear in these contexts, they do so without their present/future incompletive readings, and take on past incompletive readings (like those of Subjunctive verbs) instead. It thus appears that *wh*-movement (which fills the *wh*-projection directly above FocP in both the matrix and complement clauses) interferes with the raising of the Irrealis complement out of the scope of matrix clause PAST.

### ***The Tense Features of the Non-Modal Irrealis Marker***

Now I return to the case of non-modal Irrealis under PAST. As seen above, it allows a past-shifted future reading, which indicates that the Irrealis marker here is not a PAI, and thus does not need to raise out of the scope of matrix PAST tense. Thus, it is fair to assume that PRESENT tense is not present in the embedded Irrealis clause. I thus assume that FUTURE tense, which orders UT before RT, is present:

Irrealis under Past:

148. Nàì'    ø-nnaa Gyeeihly g-wàa'll Li'eb  
 yesterday neut-say Mike    irr-sing Felipe  
 "Yesterday, Mike said Felipe would sing"  
 [F.sings after "saying", either before or after UT]

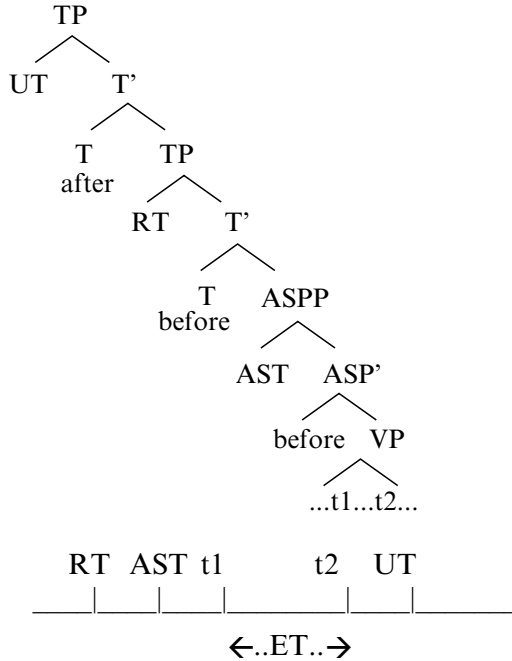

RT=time of "saying", t1-t2= time of "singing"  
 (which could include or follow UT).

The need for two separate tense specifications for modal and non-modal Irrealis aspect poses a number of interesting problems. However, I leave this issue for future research.

### 6.8.3 The Subjunctive "Aspect"

Now I turn to the Subjunctive marker, which was described briefly in the preceding section. The Subjunctive marker rarely appears on non-negated matrix clause verbs, but when it does appear, it describes incompleted actions in the past:

149. N-tò'oh Gye'eihlly c'arr  
 subj-sell Mike car  
 "Mike was going to sell the car (but didn't)"

Its more prevalent use in matrix clauses is in the expression of negated past events. Expressions that appear with Perfective marking on the verb in affirmative form often take Subjunctive-marked verbs when negated:

150. B-tòò'oh Gye'eihlly ca'rr  
 perf-sell Mike car  
 "Mike sold the car"

151. Cë'ity n-tòò'oh-dya' Gye'eihlly ca'rr  
 neg subj-sell-var Mike car  
 "Mike didn't sell the car"

Perfective verbs may also appear in past clausal negation constructions, even though Subjunctive forms are generally volunteered first:

152. Cë'ity b-tòò'oh-dya' Gye'eihlly ca'rr  
 neg perf-sell-var Mike car  
 "Mike didn't sell the car"

My consultant feels there is no difference in meaning between negated past constructions with Perfective versus Subjunctive marking on verbs.

The Subjunctive "aspect" also appears as the complement of modals and intensional verbs with past readings:

153. G-uhclàà'z-a' n-tàà'z-a' Li'eb  
 perf-want-1s subj-beat-1s Felipe  
 "I wanted to beat Felipe"

154. N-àa pahr n-tàà'z-a' Li'eb  
 neut-be for subj-hit-1s Felipe  
 "I should have hit Felipe"

Thus, the Subjunctive marker appears to be a past-tense analogue to the Irrealis marker. I assume, then, that it is licensed in the following configuration:

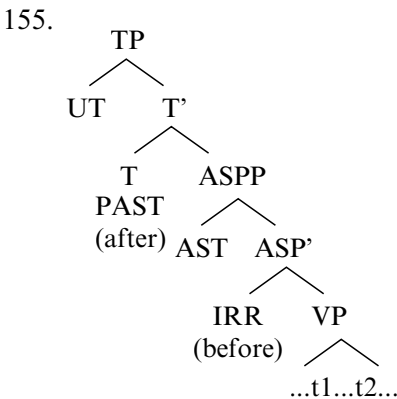

Thus, while the Irrealis marker expresses incompleted actions in the present or future, the Subjunctive marker expresses incompleted actions in the past. This structure reflects the allowable range of interpretation of Subjunctive-marked verbs. Consider, for example, the following:

156. Nàì' ø-nnaa Gye'eihlly ny-ùà'll Li'eb  
 yesterday neut-say Mike subj-sing Felipe  
 "Yesterday Mike said Felipe would sing"

One of my consultants often translates subjunctive-marked verbs as "was supposed to": He reports that (156) has a possible reading in which Mike said yesterday that Felipe was supposed to sing (before the time of Mike saying so) but the possibility of Felipe singing no longer holds at utterance time. Thus, the Subjunctive-marked verb gets a past-shifted reading here.

157.

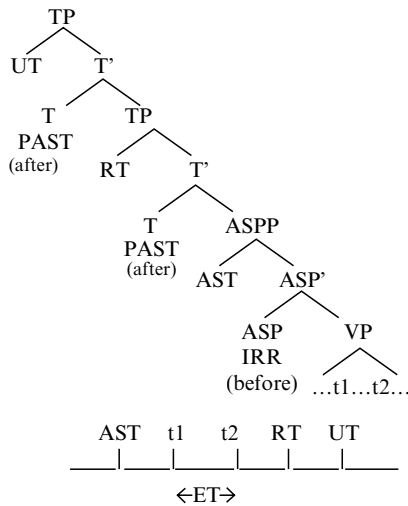

RT = time of saying, t1-t2 = time of singing.

A reading is also possible in which Felipe's singing was supposed to take place yesterday (at the same time as "saying"). The simultaneous past-tense interpretation of the matrix and embedded clauses supports the idea that the Subjunctive marker is a PPI that may be licensed by a higher PAST predicate.

Further evidence for the PPI status of the Subjunctive marker comes from the obligatory past-shifted readings of preposed Subjunctive complements of past-interpreted matrix verbs:

158. Cë'ity ny-ahcxùuw-dya' Li'eb ø-nnaa Gye'eihlly nài'  
 neg subj-be.sick-dya' Felipe neut-say Mike yesterday  
 "Yesterday, Mike said Felipe wasn't sick"  
 (Felipe hadn't been sick before yesterday/  
 \*Felipe wasn't sick yesterday)

This constraint is directly parallel to the obligatory past-shifted readings of preposed Perfective complements of past-interpreted verbs. Earlier in this chapter, I argued that this past-shifted reading results from the simultaneous interpretation of both the raised and base-generated copies of the Perfective complement, and is actually a type of double-access reading in which the Perfective complement is interpreted as expressing an event ordered in the past both with regard to the matrix past event time and the utterance time. The obligatory double-access reading of the Subjunctive complement in (158) can be accounted for in the same manner: because the Subjunctive marker, like the Perfective marker, is a PPI, the clause containing the Subjunctive verb must contain PAST tense itself in order to license the presence of the Subjunctive marker when the clause is fronted. The presence of PAST in both the matrix and complement clauses, however, means the Subjunctive verb will receive a past-shifted reading in its base-generated position. When the Subjunctive clause raises, the double-access reading results, and the apparent past-shifted reading is preserved.

The structure in (157) also accounts for the interchangeable use of the Subjunctive and Perfective markers in clausal negation constructions. Recall that the Perfective marker was defined as denoting completed events in the past, while the Subjunctive denotes incomplete events in the past. Thus, negation of an event denoted by a Perfective verb expresses the idea that a completed event did not take place—thus, the event wasn't completed. On the other hand, negation of an event denoted by a Subjunctive verb expresses the idea that an incompleting event did not take place, and thus expresses the idea that the event wasn't initiated.



In most contexts (such as (151) and (152)), these readings are pragmatically equivalent—hence, the acceptability (and apparent interchangeability) of both structures.

Unlike the Irrealis marker, the Subjunctive marker shows no difference in tense features when used as a complement of an intensional predicate.

#### 6.8.4 The Definite Aspect

The third modal aspect in SLQZ is the Definite aspect, which is mostly used to express future events. It has been called the “Definite” aspect because its use implies a strong degree of speaker presupposition about the eventuality of the future action:

159. S-tòo’oh Gye’eihlly ca’rr  
 def-sell Mike car  
 “Mike will definitely sell the car”

Thus, it provides a more emphatic expression of the probability of future events than does the Irrealis marker.

The Definite marker also appears on a small number of motion verbs (most commonly with *rihah* “go” and *rie’d* “come”) with a non-future (often past-like) reading.<sup>5</sup> The “non-future Definite” forms of “come” and “go” differ slightly in pronunciation from their future Definite forms:

160. Z-ehh Gye’eihlly Ldùu’ah  
 def-go Mike Oaxaca  
 “Mike will go to Oaxaca”
161. Z-èè Gye’eihlly Ldùu’ah  
 def-go Mike Oaxaca  
 “Mike went to Oaxaca”
162. Z-ie’d Gye’eihlly laanìh  
 def-come Mike party  
 “Mike will come to the party”

---

<sup>5</sup> Black 2004 considers the future and non-future uses of this marker to represent two distinct aspectual forms.

163. Z-iìe'd Gyeeihly laanìh  
 def-come Mike party  
 "Mike came to the party"

The non-future reading of Definite-marked verbs differs in meaning from the true past sentences constructed with Perfective-marked verbs. While past events expressed with Perfective verbs are understood as being fully completed at UT, those expressed with Definite verbs are interpreted as being initiated, but not yet fully culminated. This can be seen in the contrast between the following:

164. Gw-èe Gye'eihlly Ldùu'ah  
 perf-go Mike Oaxaca  
 "Mike went to Oaxaca (and he's already back)"
165. Z-èe Gye'eihlly Ldùu'ah  
 def-go Mike Oaxaca  
 "Mike went to Oaxaca (and he's still there/  
 hasn't returned yet)"
166. B-ìed Gye'eihlly laanìh  
 perf-come Mike party  
 "Mike came to the party (he's already at the party)"
167. Z-iìe'd Gyeeihly laanìh  
 def-come Mike party  
 "Mike came/is coming to the party  
 (he's either on his way, or has just arrived  
 but not yet started participating in the party)"

Because the readings of the Definite-marked verbs above do not reflect strictly past-tense events, I will call this usage of the Definite aspect "non-future" rather than "past". The difference in meaning between the Definite and Perfective forms above suggest a difference in aspectual structure between the Perfective aspect and the non-future Definite aspect. I will return to this issue below.

### ***The Distribution of the Future Definite Marker***

The future Definite aspect differs from the Irrealis aspect in its possible tense interpretations as well as in its propositional force. While Irrealis-marked verbs under Past matrix clauses may receive past-shifted readings (as seen in (103), repeated below), Definite-marked verbs under Past matrix clauses may not:

168. Nàì' ø-nnaa Gyeeihly g-wà'ìl Li'eb  
 yesterday neut-say Mike irr-sing Felipe  
 "Yesterday, Mike said Felipe would/will sing"  
 [F.sings after "saying", either before or after UT]
169. Nàì' ø-nnaa Gyeeihly z-à'ìl Li'eb  
 yesterday neut-say Mike def-sing Felipe  
 "Yesterday, Mike said Felipe will sing"  
 [F. sings after UT/\*F. sings after "saying but before UT]

Thus, while Irrealis-marked verbs may take past event times as their external reference times, Definite-marked verbs may not. Rather, Definite verbs may only take the matrix clause UT as their own external temporal argument. This suggests that the Definite marker like the Habitual marker, is a PAI: it may not appear under the scope of PAST tense. If this is so, then the Definite marker (at least on its future usage), like the Habitual marker, can be assumed to be licensed by the presence of PRESENT tense.

Future Definite verbs are also subject to two other syntactic constraints. First, they disallow focus-fronted subjects, as seen in (170), repeated from the preceding chapter:

170. \*Gye'ei hlly s-tò'oh ca'rr  
 Mike def-sell car  
 "MIKE will definitely sell the car"

In Lee 2005, TPs with future Definite verbs were argued to raise into FocP themselves: this movement both blocks the appearance of other focused constituents, and contributes to the emphatic reading of the sentence: the entire event denoted by the sentence is emphasized via movement into FocP.

Second, Future Definite verbs are dispreferred in clausal negation constructions:

171. \*Cë'ity z-ìe'd-dya' Gye'ei hlly laanìh  
 neg def-come-var Mike party  
 "Mike won't come to the party"

Judgments on this second point are variable: at times, they are found merely awkward, but in most cases (such as in the example above), they are found to be clearly ungrammatical.

### ***The Distribution of the Non-Future Definite Marker***

Non-future Definite verbs differ in syntactic behavior, as well as meaning, from Future Definite verbs. Unlike future Definite verbs, for instance, they may appear in sentences with focus-fronted arguments:

172. Gye'eihlly z-iie'd laanih  
 Mike def-come party  
 "MIKE is coming to the party/ is on his way to the party"

Another, more crucial, difference is that non-future Definite verbs may appear under the syntactic and semantic scope of PAST verbs:

173. Ba' rsii'lly ø-nàa Li'eb z-iie'd Gye'eihlly laanih  
 this morning neut-say Felipe def-come Mike party  
 "This morning, Felipe said Mike was coming to the party"

This can only mean that Mike was already on his way to the party at the time Felipe said so (or earlier). In short, the event denoted by the embedded Definite verb has to be initiated at or before the matrix clause past event time.

Proposed non-future Definite complements of PAST matrix clauses receive the same possible interpretations:

174. Z-iie'd Gye'eihlly laanih ba' rsii'lly ø-nàa Li'eb  
 def-come Mike party this morning neut-say Felipe  
 "This morning, Felipe said Mike was coming to the party"

Thus, unlike the Definite marker in future verbs, non-future Definite markers are not PAIs, but are rather PPIs dependent on the presence of PAST tense. When they appear as matrix clause verbs, non-future Definite verbs describe events already initiated, but not yet culminated, at UT. When embedded under PAST matrix clauses, however, they can only describe events initiated by (or before) the matrix clause past ET: they cannot describe events already initiated at UT, but not yet initiated at the matrix clause ET. This suggests that non-future Definite verbs under PAST matrix clauses are dependent on matrix PAST for their interpretation.

I will thus assume that the non-future Definite marker, like the Perfective marker, is a PPI that must be under the scope of PAST tense. In matrix clauses, the non-future Definite describes events initiated (but not yet completed) before UT. Under PAST matrix clauses, it describes events initiated at the matrix clause PAST ET (a SOT reading) or before the matrix

PAST ET (a past-shifted reading). In the former (SOT) case, the Definite marker is licensed by matrix clause PAST; in the latter, by PAST in its own clause.

Unlike embedded Perfective verbs, however, embedded non-future Definite verbs do not appear to lose their possible simultaneous past readings when preposed. This apparent difference results from the difference in aspectual structure between the Perfective and Definite aspects. While Perfective aspect highlights an AST following the ET (thus, an already completed event), Definite aspect highlights an AST before an ET (an event that hasn't been completed).

Preposed Perfective complements of PAST matrix clauses describe completed events in the past with regard to both the UT and matrix past ET (see Section 6.4.3 for the full derivation of this interpretation); the only way for the event to be interpreted as completed at both UT and ET is for it to be completed by ET (since an event completed at some past time is also complete at the present time, but not vice versa).

In contrast, preposed non-future Definite complements of PAST clauses describe events that are still incomplete at both UT and the matrix past ET. Events that are still incomplete at a present UT are necessarily incomplete at the past ET as well. Likewise, events interpreted as incomplete at the past ET are also necessarily incomplete prior to the past ET. Thus, even non-future Definite clauses containing their own PAST tense—and having past-shifted readings in their embedded positions—maintain simultaneous readings even when preposed out of the scope of matrix clause PAST.

Thus, it appears that PRESENT tense must appear when the Definite marker has a future reading, while PAST tense must appear when the Definite marker has a non-future reading.

### ***The Aspectual Features of the Definite Marker***

The Definite marker, then, may be licensed by either PAST or PRESENT tense depending on its usage. I assume that the factors uniting the future and non-future Definite markers lie in their aspectual and modal features.

As suggested above, Definite-marked verbs (on both their future and non-future readings) describe events that haven't been completed yet, but are strongly believed by speakers to be inevitable: in the future Definite case, the event described has not begun yet, but the speaker emphatically believes it will occur; in the non-future case, the event is believed by the speaker to have been initiated, but not yet completed (and the eventual completion of the event is assumed).

I will argue, then, that the aspectual features of the Definite marker are identical to those of the Irrealis and Subjunctive: the Definite marker, like

the Irrealis and Subjunctive, entails ordering the AST before the ET. AST either overlaps UT (in the case of the future Definite, where PRESENT tense governs the Definite marker) or precedes UT (in the case of the non-future Definite, where PAST orders UT after AST):

175.

Future Definite:

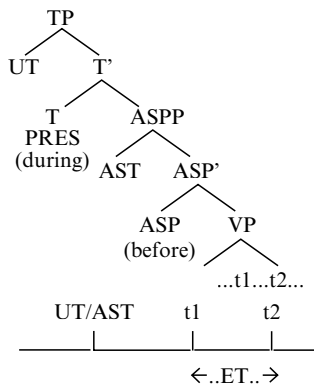

176.

Non-Future Definite:

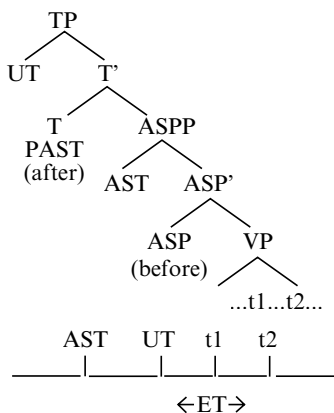

Note that the future interpretation of the Future Definite is contributed not by its tense features (as previously shown, the Future Definite marker is a PAI, and thus encodes PRESENT, rather than FUTURE, tense), but by

its aspectual features: they denote events yet to be completed. Events yet to be completed in the present can be interpreted as future events.

### ***The Modal Features of the Definite Marker***

Since the tense and aspectual features of the non-future Definite are identical to those of the Subjunctive, it is reasonable to ask why the Subjunctive describes events that were never completed, while the non-future Definite describes events that are not completed, but whose eventual completion is assumed. Likewise, it is reasonable to ask what contributes the additional level of speaker presupposition to future Definites that distinguish them from future Irrealis verbs.

What distinguishes the Definite aspect from the Subjunctive and Irrealis is the role of Mood: because Definite-marked verbs describe events speakers feel will necessarily occur, I will argue that they are also licensed by Mood features defining these events as necessarily true—that is, in all possible worlds imagined by the speaker, it is true that the event described by the Definite-marked verb will occur:

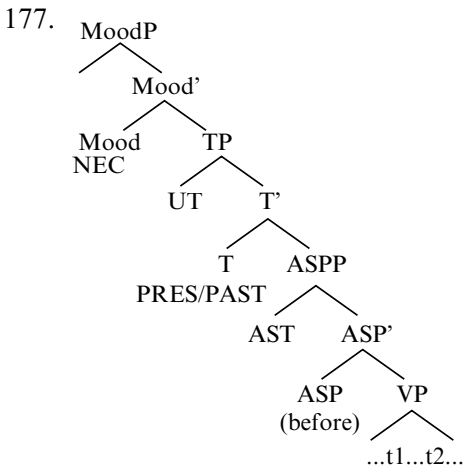

The fact that Definite verbs are marked by Mood as describing necessarily true events accounts for the previously unexplained fact that Definite verbs may not be negated. Assuming that clausal negation takes scope over entire events or propositions, rather than over single constituents, then clausal negation involving a Definite verb would result in negation of a necessarily true proposition:

178.  $\neg\text{NEC}(P)$

As is well known, “not necessarily (P)” is logically equivalent to “possibly not (P)”:

179.  $\neg\text{NEC}(P) = \text{POSS}\neg(P)$

Thus negation over an event defined as necessarily true (as in the case of Definite verbs in SLQZ) would result not in emphatic negation of a proposition (“definitely not P”), but instead, in a logically weaker negative expression (“It is possible that P won’t happen”).

The presence of Mood not only contributes to the emphatic readings of future Definite verbs, but also the “in progress” readings of non-future Definite verbs. Consider again a simple sentence with a non-future Definite verb, repeated from above:

180. Z-èè Gye’eiħly Ldùu’ah  
 def-go Mike Oaxaca  
 “Mike went to Oaxaca (and he’s still there/  
 hasn’t returned yet)”

I will argue that the Mood features marking Definite verb events as necessarily true forces non-future Definite events to be interpreted as “in progress”—while tense and mood situate the AST of the event before the event and the UT, the necessity of the event’s being carried out results (pragmatically) in the event being seen as already in progress. In short, the speaker perceives the agent of the event (Mike in this case) as necessarily intending, at some point in the past, to carry out an action (going to Oaxaca). From the perspective of the present, then, it must be the case that the action of going to Oaxaca is actually being carried out.

Thus, the necessity features contributed by Mood allow some pragmatic flexibility in the aspectual interpretation (that is, the relation between AST and ET) of Definite verbs: while AST is ordered before ET in both future and non-future Definite verbs, Mood allows non-future Definites to be interpreted as if they represented current events in progress. This is desirable because it allows the formal features of Definite aspect (AST ordered before ET) to be defined identically for both future and non-future Definite verbs. This is necessary in order to maintain the generalization that the future and non-future Definite are, despite their differences in temporal interpretation, manifestations of the same aspect and not merely different aspects that accidentally resemble each other. That the future and non-future Definite forms are indeed slightly different variants of the same form is supported by evidence from other Zapotec languages: many of these languages, like SLQZ, have homologous aspect forms that are used mostly for future events, but describe past or current events with “come” and “go”.

## 6.9 Summary

In this chapter, then, I have provided both a descriptive and theoretical overview of the expression of tense and aspect in SLQZ. First, I showed that SLQZ “aspect” markers may actually encode tense, and that in many



cases, SLQZ “aspect” markers show the same syntactic and semantic dependencies that tense markers show in overtly tense-marking languages such as English. I also showed (following Stowell 1993, 1995, and Demirdache and Uribe-Exteberria 1997) that TENSE and ASPECT are interacting syntactic predicates that take intervals of time as their arguments, and tense/aspect markers are polarity items licensed by (or blocked by) TENSE predicates with certain features. As a result, temporal interpretation in SLQZ is directly correlated with syntactic structure and can be affected by movement.

I also showed that some SLQZ “aspect” markers encode mood, as well as tense. The Irrealis and Subjunctive aspects, for instance, are used in certain contexts to represent possible world situations; in these contexts, their syntactic and semantic distribution closely parallel that of subjunctive mood in Romance and other languages. The Definite aspect encodes a different type of modality: that of necessity, rather than possibility. The presence of modal necessity in Definite-marked events is responsible for its emphatic future readings, as well as its possible usage in the representation of initiated, but not yet completed, events.

A summary of the tense, aspect, and mood features of each of the SLQZ aspect markers is below:

| Aspect Marker | Tense Features             | Aspectual Features | Mood Features                |
|---------------|----------------------------|--------------------|------------------------------|
| Perfective    | RT after ET                | AST after ET       | Indicative                   |
| Habitual      | RT = ET                    | AST contains ET    | Indicative                   |
| Progressive   | undefined                  | AST within ET      | Indicative                   |
| Neutral       | undefined                  | AST = ET           | Indicative                   |
| Irrealis      | future:<br>RT before ET    | AST before ET      | future: Indicative<br>modal: |
|               | modal: RT = ET             |                    | Possibility                  |
| Subjunctive   | RT after ET                | AST before ET      | Possibility                  |
| Definite      | future: RT = ET            | AST before ET      | Necessity                    |
|               | non-future:<br>RT after ET |                    |                              |

**Table 3.** The tense, aspect, and mood features of SLQZ “aspect” markers.

## REFERENCES

- Abusch D (1991) Sequence of tense revisited: two semantic accounts of tense in intensional contexts. Ms., Universität Stuttgart
- Aoun J, Sportiche D (1983) On the formal theory of government. *The Linguistic Review* 2, 3, 211-236.
- Awberry GM (1976) *The syntax of welsh*. Cambridge University Press, Cambridge
- Baker M (1985) The mirror pinciple and morphosyntactic representation. *Linguistic Inquiry* 16.3
- Baker M (1988) *Incorporation: a theory of grammatical function changing*. University of Chicago Press, Chicago
- Baker M (1996). *The polysynthesis parameter*. Oxford University Press, Oxford
- Barbiers S (1995) *The syntax of interpretation*. University of Leiden dissertation. HIL
- Black C (2004) *Quiégolani Zapotec syntax: a principles and parameters account*. SIL International and The University of Texas at Arlington Publications in Linguistics 136. Dallas
- Briggs E (1961) *Mitla Zapotec grammar*. Instituto Lingüístico del Verano and Centro de Investigaciones Antropológicas de México, Mexico City.
- Broadwell GA (1991) *Santa Ana del Valle--English-Spanish word list*. Ms., SUNY Albany
- Brugger G, D'Angelo M (1994) "Movement at LF triggered by mood and tense." *University of Venice Working Papers in Linguistics*, Vol. 4, no. 2.
- Burzio L (1986) *Italian syntax: a government-binding approach*. *Studies in Natural Language and Linguistic Theory*. Kluwer, Dordrecht
- Butler I (1988) *Gramática Zapoteca: Zapoteco de Yetzachi El Bajo*. Serie Gramática de Linguas Indígenas de México. Instituto Lingüístico del Verano, Mexico City.
- Carnie A (1995) *Non-verbal predication and head-movement*. Doctoral dissertation, MIT. MIT working papers in linguistics, Cambridge
- Casillas V (1995) *Causative constructions in San Lucas Quiaviní Zapotec*. Ms., UCLA.
- Cinque G (1997) *Adverbs and functional heads: a cross-linguistic perspective*. Oxford University Press, Oxford
- Chapin P (1978) "Easter Island: a characteristic VSO language." in Lehman WP, ed, *Syntactic typology: studies in the phenomenology of language*. University of Texas Press, Austin

- Chierchia G (1995) Individual-level predicates as inherent generics. In Carlson G, (ed) *The generic book*. University of Chicago Press, Chicago
- Chomsky N (1957) *Syntactic structures*. Mouton The Hague
- Chomsky N (1995) *The minimalist program*. MIT Press, Cambridge
- Chomsky N, Lasnik H (1993) Principles and parameter theory. In Jacobs J, von Stechow A, Sternefeld W, Vennemann T (eds) *Syntax: an international handbook of contemporary research*. W de Gruyter, Berlin
- Chung S (1976) *Case marking and grammatical relations in Polynesian*. Doctoral dissertation, Harvard University.
- Chung S (1990) "VPs and verb movement in Chamorro." *Natural Language and Linguistic Theory* 8:559-619.
- Chung S (1998) *The design of agreement*. Chicago University Press, Chicago
- Chung S, Timberlake A (1985) Tense, aspect, and mood. In T. Schopen, editor, *Linguistic typology and syntactic description III*. Cambridge University Press, Cambridge
- Comrie B (1985) *Tense*. Cambridge University Press, Cambridge
- Davis H, Demirdache D (2000) Two verb-initial systems in one Salish language: VSO vs. VOS in Státimcets (Lillooet Salish). Ms., University of British Columbia
- Demirdache H, Uribe-Exteberria M (1997) The primitives of temporal relations. In Martin R, Michaels D, Uriagereka J (eds.) *Step by step: essays on minimalist syntax in honor of Howard Lasnik*. MIT Press, Cambridge
- den Dikken M (1993) *Particles*. Doctoral dissertation. HIL.
- Di Sciullo AM, Williams E (1988) *On the definition of word*. MIT Press, Cambridge
- Duffield N (1994) "Are you right? On pronoun-postposing and other problems of Irish word-order." In Aronovich R, Byrne W, Preuss S, and Senturia M (eds.) *Proceedings of WCCFL 13*.
- Elbert S, Pukui MK (1979) *Hawaiian grammar*. University Press of Hawaii, Honolulu
- Emonds J (1980) "Word order and generative grammar." *Journal of linguistic research* 1.1
- Enç M (1987) Anchoring conditions for tense. *Linguistic inquiry* 18.4, 633-657.
- Farkas D (1992a) "Mood choice in complement clauses." In Kenesei I, Pléh C, eds, *Approaches to Hungarian, vol. 4: the structure of Hungarian.. JATE*
- Farkas D (1992b) "On the semantics of subjunctive complements." In Hirschbühler P, Koerner K (eds) *Romance languages and modern linguistic theory*. John Benjamins, Amsterdam/Philadelphia
- Foreman J (1999) *Preverbal subjects in Macuilianguis Zapotec*. Paper presented at the 73rd annual meeting of the Linguistic Society of America.
- Grimes B (2005) (ed) *SIL ethnologue: languages of the world*, online edition. <http://www.ethnologue.com>
- Hale K, Keyser SJ (1993) On argument structure and the lexical expression of syntactic relations. In Hale K, Kayser SJ (eds.) *The view from building 20; essays in linguistics in honor of Sylvain Bromberger*. MIT Press, Cambridge
- Heggie L (1993) The range of null operators: evidence from clefting. *Natural language and linguistic theory* 11:45-48

- Horvath J (1986) FOCUS in the theory of grammar and the syntax of Hungarian. Foris, Dordrecht
- Iatridou S (2000) The grammatical ingredients of counterfactuality. *Linguistic inquiry*, 31.2: 321-370.
- Jaeger JJ (1983) "The fortis/lenis question: evidence from Zapotec and Jawoñ." *Journal of phonetics* 11:177-189.
- Jaeggli O, Hyams N (1993) On the independence and interdependence of syntactic and morphological properties: English aspectual 'come' and 'go'. *Natural language and linguistic theory* 11.2: 313-346.
- Jones T, Knudson LM (1977) Guelavía Zapotec phonemes. In Merrifield WR (ed) *Studies in Otomanguean phonology*. Summer Institute of Linguistics/UTA.
- Kadmon N, Landman F (1990) Polarity sensitive *any* and free choice *any* Ms. Ben Gurion University of the Negev and Cornell University.
- Kaufman T (1994) Proto-Zapotec reconstructions. Ms., University of Pittsburgh.
- Kayne R (1994) The antisymmetry of syntax. MIT Press, Cambridge.
- Kayne R (1997) Overt and covert movement. Ms., New York University.
- Kenesei I (1993) A minimalist program for the syntax of focus. Ms., Department of English, University of Szeged.
- Kiss ÉK (1988) Configurationality in Hungarian. *Studies in natural language and linguistic theory*. Reidel.
- Kiss ÉK (1994) Sentence structure and word order. In *Syntax and semantics*, vol. 27: The syntactic structure of Hungarian. Academic Press, New York
- Koopman H (1996) The spec-head configuration. In Garrett E, Lee F, (eds) *Syntax at sunset*. UCLA working papers in syntax and semantics 1.
- Koopman H, Sportiche D (1991) The position of subjects *Lingua*.
- Koopman H, Szabolcsi A (1998) The Hungarian verbal complex: complex verb formation as XP movement. Ms., UCLA
- Kural M (1996) Verb incorporation and elementary predicates. UCLA dissertation.
- Kural M (1998) Case licensing and the position of the English verb. Ms., University of California, Irvine.
- Larson R (1988) On the double object construction. *Linguistic inquiry* 19.
- Lee F (1996) "Aspect, negation, and temporal polarity in Zapotec." In Agbayani B Tang S (eds.) *The proceedings of the fifteenth West Coast Conference in Formal Linguistics*. CSLI Publications, Stanford
- Lee F (1997) Focus and judgment type in San Lucas Quiavini Zapotec. In *Proceedings of BLS 23*
- Lee F (1997b) The predicational nature of clefts: evidence from Zapotec. In *Proceedings of CLS 33*
- Lee F (1998) Evidence for tense in a 'tenseless' language. In *NELS 29: proceedings from the 29<sup>th</sup> meeting of the North-East Linguistic Society*
- Lee F (2000) VP remnant movement and VSO in San Lucas Quiavini Zapotec. In Carnie A, Guilfoyle E (eds) *The syntax of verb-initial languages*, Oxford University Press, Oxford
- Lee F (2003) Anaphoric R-expressions as bound variables. *Syntax* 6.1, pp 84-114

- Lee F (2005) Force first: clause fronting and clause typing in San Lucas Quiavini Zapotec. In Carnie A, Harley H, Dooley SA, editors, *Verb first: on the syntax of verb-initial languages*. John Benjamins Publishing Company, Amsterdam/Philadelphia
- Lee F, Ouhalla J (1998) "Remnant VP movement and VSO in Quiavini Zapotec and Berber." Ms., UCLA and Queen Mary and Westfield College.
- López Cruz A (1997) *Morfología verbal del zapoteco de San Pablo Güilá*. Tesis (licenciada en lingüístico), Escuela Nacional de Antropología e Historia, México, D.F.
- Marks D (undated) *Morphophonemics of the Guevea de Humboldt Zapotec verb*. Ms., Summer Institute of Linguistics.
- Marlett SA (1993) Zapotec pronoun classification. *International Journal of American Linguistics*: 59: 82-101.
- Massam D (2000) VSO and VOS: Aspects of Niuean word order. In Carnie A, Guilfoyle E (eds) *The syntax of verb-initial languages*, Oxford University Press, Oxford
- McCawley J (1988) *The syntactic phenomena of English*. Chicago University Press, Chicago
- McCloskey J (1991) Clause structure, ellipsis, and proper government in Irish. In *The syntax of verb initial languages: Lingua special edition 85*.
- Moritz L, Valois D (1992) French sentential negation and LF pied-piping. *Linguistic inquiry*.
- Munro P (1995) Coreference phenomena in San Lucas Quiavini Zapotec. Ms. UCLA.
- Munro P (1996) Making a Zapotec dictionary. *Dictionaries* 17.
- Munro P, Lopez F (with Rodrigo Garcia and Olivia V.Méndez) (1999). *Diccionario x:te'e'n di:I'zh sah Sann Luu'c: San Lucas Quiavini Zapotec dictionary*. *Diccionario Zapoteco de San Lucas Quiavini*. UCLA Chicano Studies Research Center Publications, Los Angeles
- Nakajima T (1996) Remnant VP raising and word order under the LCA. Paper presented at the Sixth Colloquium on Generative Grammar.
- Nellis D, Hollenbach B (1980) Fortis vs. lenis in Cajonos Zapotec phonology. *International journal of American Linguistics* 49.
- Nkemnji M (1995) Heavy pied-piping in Nweh. Doctoral dissertation, UCLA.
- Noonan M (1999) "What is the nature of successive-cyclic WH-movement?" Paper presented at WCCFL 18. To appear in *Proceedings of WCCFL 18*.
- Nyonyani D (1996) *The morphosyntax of applicatives*. Doctoral dissertation, UCLA
- Ogihara T (1996) *Tense, attitudes and scope*. Kluwer Academic Publishers, Dordrecht.
- Ouhalla J (1997) "Remarks on focus in Standard Arabic." In Mushira Eid and Robert Radcliffe, editors, *Perspectives on Arabic linguistics X*. John Benjamins Publishing Company, Amsterdam/Philadelphia
- Partee B (1973) Some structural analogies between tenses and pronouns in English. *The journal of philosophy* 70.
- Pearson JM (1997) Feature inheritance and remnant movement: deriving SOV order under the LCA. Paper presented at the LSA Summer Institute.

- Pesetsky D (1995) *Zero syntax: experiencers and cascades*. Cambridge: MIT Press.
- Pickett V, Black C, Vicente Marcial C (1998) *Gramática popular del zapoteco de Istmo*. Centro de investigación y desarrollo. Binniza A.C and Instituto lingüístico de Verano: Oaxaca and Tucson.
- Pickett, Velma, Cheryl Black and Vicente Marcial C 2001. *Gramática popular del zapoeco de Istmo*. Online edition <http://www.sil.org/mexico/zapoteca/istmo/G023a-GramaticaZapistmoZAI.htm>
- Pollock J-Y (1989) "Verb movement, UG, and the structure of IP" *Linguistic inquiry* 20.
- Potter B (1995) *Minimalism and the mirror principle*. In NELS 26: proceedings of the 26th meeting of the North-East Linguistic Society. Harvard and MIT.
- Potter B (1997) *WH-Indefinites and the structure of the clause in Western Apache*. Doctoral dissertation, UCLA
- Quer J (1998) *Mood at the interface*. Doctoral dissertation, HIL.Holland Academic Graphics, Leiden
- Rackowski A, Travis L (2000) *V-Initial languages: X or XP movement and adverbial placement*. In Carnie A, Guilfoyle E (eds), *The syntax of verb-initial languages*. Oxford University Press, Oxford
- Reinhart T (1981) *Syntactic domains for semantic rules*. In Guenther and Schmidt, editors, *Formal semantics and pragmatics for natural languages*. Reidel.
- Rizzi L (1997) *The fine structure of the left periphery*. In Haegeman L (ed) *Elements of grammar: handbook of generative syntax*. Kluwer Academic Publishers, Dordrecht. .
- Shumway E (1988) *Intensive course in Tongan*. The Institution for Polynesian Studies, Brigham Young University: Hawaii.
- Stowell T (1981) *Origins of phrase structure*. Doctoral dissertation, MIT
- Stowell Tim (1993) *The phrase structure of tense*. In Rooryck J, Zaring L (eds) *Phrase structure and the lexicon*. Kluwer Academic Publishers, Dordrecht
- Stowell T (1995) *What do the present and past tenses mean?* In Bertinetto PM, Bianchi V, Higginbotham J, Squartini M (eds) *Temporal reference, aspect, and actionality*. Vol. 1: semantic and syntactic perspectives. Rosenberg and Sellier, Torino
- Stubblefield M, Stubblefield C (1991) *Diccionario Zapoteca de Mitla*. Oaxaca serie de vocabularios y diccionarios indígenas. número 31. Instituto Lingüístico del Verano, Mexico City.
- Szabolcsi A, Zwarts F (1993) *Weak islands and an algebraic semantics for scope-taking*. *Natural language semantics* 1.
- Vergnaud J-R (1974) *French relative clauses*. Doctoral dissertation, MIT.
- Zagona K (1990) *Times as temporal argument structure*. Presented at the Time in Language Conference, MIT.
- Zanuttini R (1991) *Syntactic properties of sentential negation. A comparative study of romance languages*. Doctoral dissertation, University of Pennsylvania.
- Zwart CJW (1993). *Dutch syntax: A minimalist approach*. Doctoral dissertation, Rijksuniversiteit Groningen.