

The Steel
Construction
Institute

Introduction to Steelwork Design to BS 5950-1:2000

Commentaries to Standards



The Steel Construction Institute

The Steel Construction Institute develops and promotes the effective use of steel in construction. It is an independent, membership based organisation.

SCI's research and development activities cover many aspects of steel construction including multi-storey construction, industrial buildings, light steel framing systems and modular construction, development of design guidance on the use of stainless steel, fire engineering, bridge and civil engineering, offshore engineering, environmental studies, value engineering, and development of structural analysis systems and information technology.

Membership is open to all organisations and individuals that are concerned with the use of steel in construction. Members include designers, contractors, suppliers, fabricators, academics and government departments in the United Kingdom, elsewhere in Europe and in countries around the world. The SCI is financed by subscriptions from its members, revenue from research contracts and consultancy services, publication sales and course fees.

The benefits of corporate membership include access to an independent specialist advisory service and free issue of SCI publications as soon as they are produced. A Membership Information Pack is available on request from the Membership Manager.

The Steel Construction Institute, Silwood Park, Ascot, Berkshire, SL5 7QN.

Telephone: +44 (0) 1344 623345

Fax: +44 (0) 1344 622944

Email: membership@steel-sci.com

For information on publications, telephone direct: +44 (0) 1344 872775

or Email: publications@steel-sci.com

For information on courses, telephone direct: +44 (0) 1344 872776

or Email: education@steel-sci.com

World Wide Web site: <http://www.steel-sci.org>

SCI PUBLICATION P325

Introduction to Steelwork Design to BS 5950-1:2000

A G J Way MEng CEng MICE

and the late

P R Salter BSc CEng MIStructE

Published by:
The Steel Construction Institute
Silwood Park
Ascot
Berkshire SL5 7QN

Tel: 01344 623345

Fax: 01344 622944

© 2003 The Steel Construction Institute

Apart from any fair dealing for the purposes of research or private study or criticism or review, as permitted under the Copyright Designs and Patents Act, 1988, this publication may not be reproduced, stored or transmitted, in any form or by any means, without the prior permission in writing of the publishers, or in the case of reprographic reproduction only in accordance with the terms of the licences issued by the UK Copyright Licensing Agency, or in accordance with the terms of licences issued by the appropriate Reproduction Rights Organisation outside the UK.

Enquiries concerning reproduction outside the terms stated here should be sent to the publishers, The Steel Construction Institute, at the address given on the title page.

Although care has been taken to ensure, to the best of our knowledge, that all data and information contained herein are accurate to the extent that they relate to either matters of fact or accepted practice or matters of opinion at the time of publication, The Steel Construction Institute, the authors and the reviewers assume no responsibility for any errors in or misinterpretations of such data and/or information or any loss or damage arising from or related to their use.

Publications supplied to the Members of the Institute at a discount are not for resale by them.

Publication Number: SCI P325

ISBN 1 85942 141 5

British Library Cataloguing-in-Publication Data.

A catalogue record for this book is available from the British Library.

FOREWORD

This publication replaces an earlier SCI publication (P069) that provided guidance on the first issue of the design code for steelwork in buildings (BS 5950-1:1985). A revised design code, (BS 5950-1:2000), which incorporated significant technical revisions, came into effect in 2001 and this led to the need to update that earlier guidance.

The material in the present publication has been updated to the latest issue of BS 5950-1 and is presented in 15 principal Sections. Guidance is offered on all the main technical subjects in the Code. Further guidance on the application of the Code can be found in a second SCI publication *Steelwork design guide to BS 5950-1:2000, Volume 2: Worked examples* (P326).

The present publication has been prepared by Mr Andrew Way of The Steel Construction Institute and incorporates additional lecture material produced by the late Mr Paul Salter. Paul was a well-respected colleague who made invaluable contributions to the development of the publication and SCI wishes to express its gratitude for his input.

Further advice and guidance was received during the drafting from Mr Abdul Malik and Mr Charles King both of The Steel Construction Institute.

The preparation of this publication was funded by Corus plc and their support is gratefully acknowledged.

[Discuss me ...](#)

Contents

| | Page No. |
|--|-----------------|
| FOREWORD | iii |
| SUMMARY | viii |
| 1 INTRODUCTION TO BS 5950-1:2000 AND LIMIT STATE CONCEPT | 1 |
| 1.1 Introduction | 1 |
| 1.2 Aims of structural design | 2 |
| 1.3 Methods of design | 2 |
| 1.4 Limit states design | 3 |
| 1.5 Limit states | 6 |
| 1.6 Ultimate limit states | 6 |
| 1.7 Serviceability limit states | 16 |
| 1.8 Summary of design procedure | 18 |
| 2 PROPERTIES OF STEEL | 19 |
| 2.1 Introduction | 19 |
| 2.2 Strength | 21 |
| 2.3 Brittle fracture | 21 |
| 3 LOCAL BUCKLING AND SECTION CLASSIFICATION | 24 |
| 3.1 Introduction | 24 |
| 3.2 Section classification | 24 |
| 3.3 Section classification examples | 28 |
| 3.4 Effective section properties | 31 |
| 3.5 Examples of effective section property calculation | 36 |
| 3.6 Summary of design procedure | 39 |
| 4 TENSION MEMBERS | 41 |
| 4.1 Introduction | 41 |
| 4.2 Material properties | 41 |
| 4.3 Effective area in tension | 42 |
| 4.4 Allowance for eccentricity | 43 |
| 4.5 Summary of design procedure | 45 |
| 5 COMPRESSION MEMBERS | 46 |
| 5.1 Introduction | 46 |
| 5.2 Slenderness | 46 |
| 5.3 Effective length | 46 |
| 5.4 Compressive strength | 48 |
| 5.5 Section classification | 50 |
| 5.6 Members in lattice frames and trusses | 51 |
| 5.7 Members in continuous construction | 51 |
| 5.8 Summary of design procedure | 51 |
| 6 RESTRAINED BEAMS | 53 |
| 6.1 Introduction | 53 |
| 6.2 Lateral restraint | 53 |
| 6.3 Section Classification | 54 |
| 6.4 Shear | 54 |
| 6.5 Combined bending and shear | 55 |
| 6.6 Web bearing and buckling | 57 |

| | | |
|-------|---|-----|
| 6.7 | Deflection | 57 |
| 6.8 | Summary of design procedure | 58 |
| 7 | UNRESTRAINED BEAMS | 60 |
| 7.1 | Introduction | 60 |
| 7.2 | Factors influencing buckling resistance | 61 |
| 7.3 | Behaviour of beams | 61 |
| 7.4 | Design requirements | 62 |
| 7.5 | Effective length | 64 |
| 7.6 | Equivalent uniform moment factor | 67 |
| 7.7 | Deflection | 71 |
| 7.8 | Summary of design procedure | 71 |
| 8 | BEAM WEB DESIGN | 72 |
| 8.1 | Introduction | 72 |
| 8.2 | Web subject to concentrated loads | 72 |
| 8.3 | Openings in beam webs | 75 |
| 9 | MEMBERS SUBJECT TO AXIAL LOAD AND BENDING | 79 |
| 9.1 | Introduction | 79 |
| 9.2 | Section classification | 79 |
| 9.3 | Tension members with moments | 80 |
| 9.4 | Compression members with moments | 83 |
| 9.5 | Summary of design procedure | 87 |
| 10 | COLUMNS IN SIMPLE STRUCTURES | 90 |
| 10.1 | Introduction | 90 |
| 10.2 | Section classification | 91 |
| 10.3 | Column moments | 91 |
| 10.4 | Effective length of columns | 93 |
| 10.5 | Slenderness | 93 |
| 10.6 | Compressive strength | 93 |
| 10.7 | Buckling resistance | 93 |
| 10.8 | Interaction | 94 |
| 10.9 | Loads and forces | 94 |
| 10.10 | Summary of design procedure | 95 |
| 11 | CONNECTIONS | 96 |
| 11.1 | General | 96 |
| 11.2 | Bolted connections | 100 |
| 11.3 | Welded connections | 108 |
| 11.4 | Baseplates | 113 |
| 11.5 | Summary of design procedure | 115 |
| 12 | PLASTIC DESIGN OF PORTAL FRAMES | 116 |
| 12.1 | Introduction | 116 |
| 12.2 | Plastic analysis | 116 |
| 12.3 | Frame stability | 117 |
| 12.4 | Deflections | 122 |
| 12.5 | Member Stability | 123 |
| 12.6 | Summary of design procedure | 127 |
| 13 | PLATE GIRDERS | 128 |
| 13.1 | Introduction | 128 |
| 13.2 | General considerations | 129 |

| | | |
|------|--|-----|
| 13.3 | Design strength | 129 |
| 13.4 | Minimum requirements for webs | 130 |
| 13.5 | Moment capacity | 131 |
| 13.6 | Shear buckling resistance | 133 |
| 13.7 | Stiffeners | 137 |
| 13.8 | Loads applied between stiffeners | 142 |
| 13.9 | Summary of design procedures | 143 |
| 14 | CONTINUOUS MULTI-STOREY FRAMES | 144 |
| 14.1 | Introduction | 144 |
| 14.2 | Loading | 145 |
| 14.3 | Frame analysis | 146 |
| 14.4 | Connection properties | 146 |
| 14.5 | Frame classification | 146 |
| 14.6 | Elastic design of continuous multi-storey frames | 147 |
| 14.7 | Plastic design of continuous multi-storey frames | 156 |
| 14.8 | Summary of design procedure | 156 |
| 15 | CRANE GANTRY GIRDERS | 158 |
| 15.1 | Introduction | 158 |
| 15.2 | Crane girder loading | 158 |
| 15.3 | Lateral torsional buckling | 162 |
| 15.4 | Web shear | 162 |
| 15.5 | Local compression under wheels | 162 |
| 15.6 | Welding | 163 |
| 15.7 | Deflection limits | 163 |
| 15.8 | Summary of design procedure | 163 |
| 16 | REFERENCES | 164 |
| | APPENDIX A: Plastically designed portal frame (Worked Example) | 169 |
| A.1 | Frame dimensions and loading | 169 |
| A.2 | Selecting initial member sizes | 169 |
| A.3 | Design checks | 170 |
| A.4 | Graphs for initial portal frame member selection | 184 |

SUMMARY

This publication provides design guidance on the use of BS 5950-1:2000. Introductory and background information has been included to make the publication easy to follow and also suitable to those with limited experience of BS 5950-1. Cross-references to Code clauses and explanations of how the Code clauses should be applied under certain situations are provided. The publication covers the design of all the main structural forms and their components.

1 INTRODUCTION TO BS 5950-1:2000 AND LIMIT STATE CONCEPT

1.1 Introduction

BS 5950-1:2000^[1] supersedes BS 5950-1: 1990, which is now withdrawn. The new Standard includes technical changes from the previous Standard but it does not constitute a full revision.

The new Standard takes account of a number of new related standards adopting European or International standards for materials and processes, plus revisions to standards for loading. It also reflects the transfer of the design of cold-formed structural hollow sections from BS 5950-5 to BS 5950-1:2000.

The clauses that have been updated technically include those for sway stability, resistance to brittle fracture, local buckling, lateral-torsional buckling, shear resistance, stiffeners, members subject to combined axial force and bending moment, joints, connections and testing. Descriptions of the major changes are given in SCI publication P304^[2]. The reason for many of the changes to the recommendations is one of structural safety. However, where possible some adjustments based on improved knowledge have also been made to the recommendations to offset potential reductions in economy.

BS 5950^[1] is a Standard combining codes of practice covering the design, construction and fire protection of steel structures and specifications for materials, workmanship and erection. It comprises the following parts:

- Part 1: Code of practice for design - Rolled and welded sections
- Part 2: Specification for materials, fabrication and erection - Rolled and welded sections
- Part 3: Design in composite construction - Section 3.1: Code of practice for the design of simple and continuous composite beams
- Part 4: Code of practice for design of composite slabs with profiled steel sheeting
- Part 5: Code of practice for design of cold-formed thin gauge sections
- Part 6: Code of practice for design of light gauge profiled steel sheeting
- Part 7: Specification for materials, fabrication and erection – Cold-formed sections and sheeting
- Part 8: Code of practice for fire resistant design
- Part 9: Code of practice for stressed skin design.

It should be noted that all these parts are Codes of Practice except for Parts 2 and 7, which are Specifications. This distinction is made because, in order for the design rules in the codes to be valid, the steel, the fabrication and erection must be of a specified quality. For example, the rules for compression members in Part 1 are written assuming that the members are within a certain tolerance on straightness (given in BS 5950-2^[1] as Length/1000). If the members were outside this tolerance the rules would not be valid.

This publication relates principally to the use of Part 1, which forms the basis for the other parts of the Code and can be used for steel structures where no other suitable code exists.

1.1.1 Scope of BS 5950-1:2000

BS 5950-1^[1] is intended for the design of structural steelwork using hot rolled sections, flats plates, hot-finished and cold-formed structural hollow sections. It is intended primarily for building structures and other structures not specifically covered by other standards. The recommendations assume that the standards of construction are as specified in BS 5950-2^[1].

Cl. 1.1

1.1.2 Simplifications

In order to simplify the text of the Standard, some of the more complex design rules that were previously within the body of the code have been transferred to the annexes and the simpler methods are described as general methods to avoid excessive work in the normal design situations. In other cases, where the design is of a specialist nature, reference is now made to publications produced by specialist bodies.

1.2 Aims of structural design

The main aim of structural design is to design a safe structure that will fulfil its intended purpose. The structure should be able to resist the predicted loading for its entire design life with a sufficient margin of safety. The in-service deflections and behaviour of the structure must not be such that it is unacceptable for the intended use.

Cl. 2.1.1.1

Other factors that should also be considered in the design stage are economy, safety, erection, transport and sustainability.

Cl. 2.1.1.1

1.3 Methods of design

The Standard describes three basic design methods that are recognised for use with structural steelwork. The methods are summarised here in Table 1.1. The connection details adopted in practice should fulfil the assumptions made in the analysis and hence be suitable for the chosen design method.

Cl. 2.1.2

This publication will generally assume that 'simple' design is used to determine forces in the members unless stated otherwise.

Table 1.1 *Summary of design methods*

| Design | Analysis | Connections | Comments |
|--------------------------|-----------------|------------------------------------|--|
| Simple | Pin joints | Nominally pinned | An economic method for braced multi-storey frames. Connection design is for strength only (plus robustness requirements, see Section 1.6.6). Both in-plane and out-of-plane bracing is required. |
| Continuous | Elastic | Rigid | In conventional elastic analysis, connections are designed for forces and moments. In plastic analysis, plastic hinges form in the adjacent member, not in the connections. Elastic plastic analysis is popular for portal frame design where joints are considered full strength and rigid. Generally, joints should have sufficient rotational stiffness for in-plane stability. |
| | Plastic | Full strength | |
| | Elastic-Plastic | Full strength and rigid | |
| Semi - continuous | Elastic | Semi-rigid | Elastic analysis is not ideal for semi-continuous design because it requires quantification of connection stiffness, which may prove difficult in practice. |
| | See ref. 3 & 4 | Partial strength and ductile | SCI publication P183 ^[3] provides a design method for semi-continuous braced frames. SCI publication P263 ^[4] details the wind-moment method for unbraced frames. |
| | Elastic-Plastic | Partial strength and/or semi-rigid | Full connection properties are modelled in the analysis. Currently used more for research than for practical design. |

Cl. 2.1.2.2

Cl. 2.1.2.3

Cl. 2.1.2.3

1.4 Limit states design

1.4.1 General

Nearly all modern codes, including BS 5950, are written in terms of Limit States Design, which allows a more consistent factor of safety against failure and more economical use of materials than the working stress approach adopted by older codes. Factors are applied both to the loads and to the materials, to allow for the possibility that the loads may be greater than the assumed values and that the materials may be weaker than the assumed values. The design requirement is often expressed as:

$$F \times \gamma_l \leq R / \gamma_m$$

where:

- F is the load effect (e.g. force or moment)
- γ_l is the load factor
- R is the resistance or capacity of the member
- γ_m is the material factor

Annex A

The factors applied in practice are a combination of a number of different factors that take account of different aspects of the construction process. These factors are described in Table 1.2.

Table 1.2 *Partial factors*

| Symbol | Description |
|---------------|--|
| γ_{11} | Load factor – which allows for the load being more or less than predicted. |
| γ_{12} | Combination factor - which allows for the unlikelihood of all loads in the combination being at their maximum at any one time. |
| γ_{m1} | Material factor - for resistances based on yield strength - which takes account of variations in material strength and manufacturing tolerances. |
| γ_{m2} | Material factor - for resistances based on ultimate tensile strength - which takes account of variations in material strength and manufacturing tolerances. |
| γ_p | Performance factor – which takes account of the difference between actual behaviour and that assumed in design (e.g. continuity of connections and detailing). |

Annex A

Using the partial factors in Table 1.2, the design requirement can be expressed more fully as:

$$F \times \gamma_{11} \times \gamma_{12} \times \gamma_p \leq R / (\gamma_{m1} \text{ or } \gamma_{m2})$$

In BS 5950 the γ factors have been combined to simplify the design. The performance factor ($\gamma_p \approx 1.2$) has been combined with the load factors ($\gamma_{\text{Dead Load}} \approx 1.15$ and $\gamma_{\text{Imposed Load}} \approx 1.3$). The material factors (γ_{m1} and γ_{m2}) are combined into the recommended design strengths.

Therefore, when designing to BS 5950, the relationship which has to be satisfied is simply:

$$F \times \gamma_f \leq R$$

where:

γ_f is the product of γ and γ_p and is given in Table 2 of the Standard.

However, if the concept of limit state design is to be employed effectively, an understanding of the variation of both the materials and the loads is needed.

1.4.2 Material strength variation

Figure 1.1 shows a distribution curve for a series of events with an equal distribution of results either side of the target value. If the material strength is very consistent then the curve will be steep and the scatter of results either side of the line will be very small.

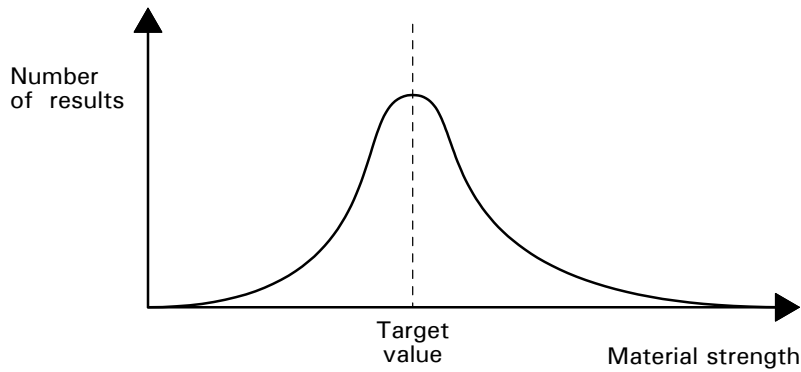


Figure 1.1 Typical distribution curve for material strength

In practice, because the strength of steel is quoted by the steel specifications as a “guaranteed minimum”, the curve for steel strength is similar to that shown in Figure 1.2. In this case the number of results falling below the guaranteed minimum is very small. The mean strength of the steel is close to 310 N/mm², but the 95% confidence limit (i.e. mean minus 2 standard deviations) is 275 N/mm². This in part explains why the material factor for structural steel is usually taken as 1.0, for design to BS 5950-1.

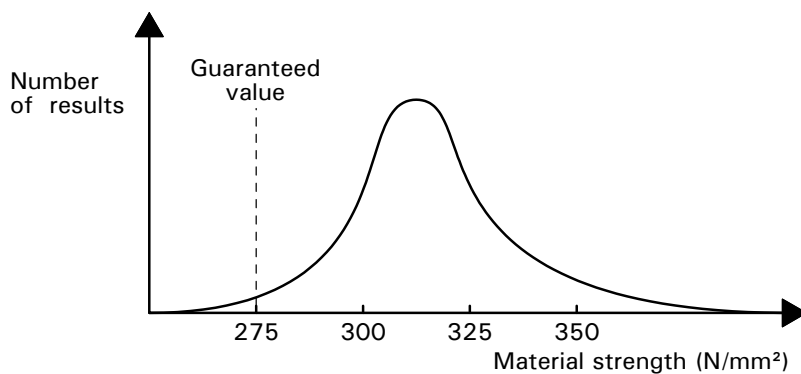


Figure 1.2 Typical curve for steel grade S275

In addition to material strength, there are also a number of other factors that must be taken into account in assessing the strength of the structure, such as tolerances of the members and the workmanship during fabrication. These issues are usually the concern of the code-drafting panel and have been taken into account in setting the partial factor values.

1.4.3 Load variation

The actual load to which a structure is subjected can vary from the assumed level of load. As our knowledge of load effects increases, the likelihood of actual values falling above the specified value should decrease and we can use a lower load factor with confidence.

For example, a considerable amount of work has been carried out by BRE^[5] over the past few years on wind loads and this partly explains why the load factor on wind load is less than that for other imposed loading.

1.5 Limit states

BS 5950-1^[1] considers two classes of limit states. The ultimate limit state (i.e. the point beyond which the structure would be unsafe) and the serviceability limit state (i.e. the point beyond which the specified service criteria are no longer met). The principal limit states covered in BS 5950-1 are shown in Table 1.3.

Cl. 2.1.3

Table 1.3 *Limit states*

| Ultimate Limit States (ULS) | Serviceability Limit State (SLS) |
|--|----------------------------------|
| Strength (yielding, rupture, buckling and forming a mechanism) | Deflection Vibration |
| Stability against overturning and sway stability | Wind induced oscillation |
| Fracture due to fatigue | Durability |
| Brittle fracture | |

Table 1

1.6 Ultimate limit states

1.6.1 Application of load factors

When the structure reaches a limit state of strength or stability it is on the point of being unsafe or about to collapse. It is necessary to verify that there is an adequate factor of safety against this limiting condition.

For steel design the load factors γ given in BS 5950-1 Table 2 are applied to the specified loads. A summary of Table 2 is given in Table 1.4.

Cl. 2.4
Table 2

In buildings not subject to loads from travelling cranes, the following load combinations should be checked:

Cl. 2.4.1.2

- Load combination 1: Dead load and imposed load (gravity loads) plus notional horizontal forces (see Section 1.6.3)
- Load combination 2: Dead load and wind load
- Load combination 3: Dead load, imposed load and wind load.

For buildings that are subject to loads from travelling cranes, the load combinations are given in BS 5950-1.

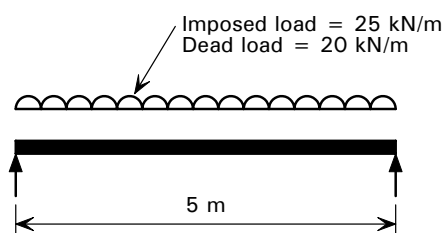
Cl. 2.4.1.3

Table 1.4 *Partial factors for loads*

| Loading | Load Factor γ |
|---|----------------------|
| Dead load | 1.4 |
| Dead load restraining uplift or overturning | 1.0 |
| Dead load acting with wind load and imposed load | 1.2 |
| Imposed loads | 1.6 |
| Imposed load acting with wind load | 1.2 |
| Wind load | 1.4 |
| Wind load acting with imposed load | 1.2 |
| Exceptional snow load (due to drifting) | 1.2 |
| Forces due to temperature effects | 1.2 |
| Vertical crane loads | 1.6 |
| Vertical crane loads acting with horizontal loads | 1.4 |
| Horizontal crane loads | 1.6 |
| Horizontal crane loads acting with vertical | 1.4 |
| Crane load acting with wind load | 1.2 |

Example 1

The simple case of a beam spanning between two supports is shown in Figure 1.3.

**Figure 1.3** *Load on simply supported beam*

Load combination 1: Dead load + Imposed load

$$\begin{aligned} \text{Ultimate load} &= 1.4 \text{ Dead load} + 1.6 \text{ Imposed load} \\ &= (1.4 \times 20) + (1.6 \times 25) = 68 \text{ kN/m} \end{aligned}$$

Example 2

The loading on the roof of a single storey building is shown in Figure 1.4. The maximum uplift is determined from load combination 2 (Dead load + Wind load). If there is a net uplift on the roof, the result is a reversal of forces in the members.

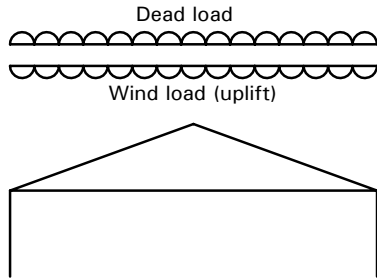


Figure 1.4 *Wind uplift counteracted by dead load*

$$\text{Ultimate load (uplift)} = 1.0 \text{ Dead load} + 1.4 \text{ Wind load}$$

Example 3

A beam with a 1 m cantilever and an imposed load of 100 kN at the end is shown in Figure 1.5. The maximum positive reaction at B and the maximum negative reaction at C are required.

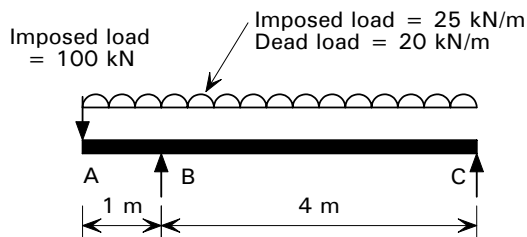


Figure 1.5 *Cantilever beam*

The maximum positive reaction at B occurs when there is maximum load on the whole beam.

Load combination 1: Dead load + Imposed load

$$\text{Ultimate load} = 1.4 \text{ Dead load} + 1.6 \text{ Imposed load}$$

Calculate the reaction at B by taking moments about C.

The maximum positive reaction at B, $R_B =$

$$\begin{aligned} & [(1.4 \times 20 \times 5 \times 2.5) + (1.6 \times 25 \times 5 \times 2.5) + (1.6 \times 100 \times 5)] / 4 \\ & = 412.5 \text{ kN} \end{aligned}$$

The corresponding reaction at C, $R_C =$

$$(1.4 \times 20 \times 5) + (1.6 \times 25 \times 5) + (1.6 \times 100) - 412.5 = 87.5 \text{ kN}$$

The minimum reaction at C occurs when there is a maximum load on AB and a minimum load on BC.

Load combination 1: Dead load + Imposed load

$$\text{Ultimate load (AB)} = 1.4 \text{ Dead load} + 1.6 \text{ Imposed load}$$

$$\text{Ultimate load (BC)} = 1.0 \text{ Dead load}$$

Calculate the reaction at C by taking moments about B.

$$(1.4 \times 20 \times 1 \times 0.5) + (1.6 \times 25 \times 1 \times 0.5) + (1.6 \times 100 \times 1) \dots$$

$$\dots - (1.0 \times 20 \times 4 \times 2) + R_C \times 4 = 0$$

$$\therefore R_C = -8.5 \text{ kN}$$

Thus, the minimum reaction at C is an uplift of 8.5 kN and a holding down system would have to be provided.

Note that the two reactions evaluated above are both achieved by using load combination 1 but the second (negative) reaction is obtained by using a reduced load factor on the dead load when it is counteracting uplift.

Example 4

A gantry structure, subjected to wind loads is shown in Figure 1.6.

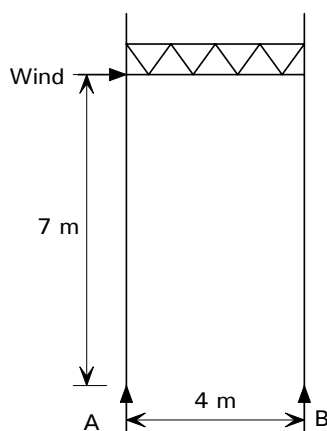


Figure 1.6 Wind load acting on a gantry structure

Loading data

| | |
|--|----------|
| Platform dead load (including self weight) | = 3.0 kN |
| Platform imposed load (people) | = 3.5 kN |
| Self weight of each gantry column | = 2.0 kN |
| Wind load (with people) | = 5.0 kN |
| Wind load (without people) | = 4.0 kN |

A number of load combinations should be considered:

Load combination 1: Dead load + Imposed load [with people]

Note: In this case notional horizontal forces should also be included (see Section 1.6.3), for this example they will be omitted.

$$\begin{aligned} \text{Ultimate load} &= 1.4 \text{ Dead load} + 1.6 \text{ Imposed load} \\ &= 1.4 (3 + 2 + 2) + 1.6 (3.5) = 15.4 \text{ kN} \end{aligned}$$

$$\text{Thus the reaction at A, } R_A = 15.4 / 2 = 7.7 \text{ kN}$$

$$\text{and the reaction at B, } R_B = 15.4 / 2 = 7.7 \text{ kN}$$

Load combination 2a: Dead Load + Wind load [without people]

Ultimate load = 1.4 Dead load + 1.6 Imposed load

Dead load restraining uplift, $\gamma_{DL} = 1.0$

Take moments about B:

$$(R_A \times 4) - (1.0 \times 2 \times 4) - (1.0 \times 3 \times 2) + (1.4 \times 4 \times 7) = 0$$

Thus $R_A = -6.3$ kN (uplift)

Load combination 2b: Dead Load + Wind load [without people]

Ultimate load = 1.4 Dead load + 1.4 Wind load

Dead load not restraining uplift, $\gamma_{DL} = 1.4$

Take moments about A:

$$(1.4 \times 2 \times 4) + (1.4 \times 3.0 \times 2) + (1.4 \times 4 \times 7) - (R_B \times 4) = 0$$

Thus $R_B = 14.7$ kN

Load combination 3a: Dead Load + Imposed Load + Wind load [with people]

Ultimate load = 1.0 Dead Load + 1.2 Imposed Load + 1.2 Wind load

Dead load restraining uplift, $\gamma_{DL} = 1.0$

Take moments about B:

$$(R_A \times 4) - (1.0 \times 2 \times 4) - (1.0 \times 3 \times 2) \dots \\ \dots - (1.2 \times 3.5 \times 2) + (1.2 \times 5 \times 7) = 0$$

Thus $R_A = -4.9$ kN (uplift)

Load combination 3b: Dead Load + Imposed Load + Wind load

Ultimate load = 1.2 Dead Load + 1.2 Imposed Load + 1.2 Wind load

Dead load not restraining uplift, $\gamma_{DL} = 1.2$

Take moments about A:

$$(1.2 \times 2 \times 4) + (1.2 \times 3 \times 2) + (1.2 \times 3.5 \times 2) + \dots \\ \dots (1.2 \times 5 \times 7) - (R_B \times 4) = 0$$

Thus $R_B = 16.8$ kN

The maximum reaction at B (and compression in the column above) equals 16.8 kN (load combination 3b) and the minimum reaction (and tension in the column above) at A = -6.3 kN (load combination 2a).

The base would need anchoring down to a concrete base to prevent uplift. An adequate safety factor against uplift has already been provided in the calculation of the value of uplift and therefore the required tensile resistance of the holding down bolts and weight of concrete required is 6.3 kN.

1.6.2 Capacity and Resistance

When checking members or structures at the ultimate limit state it is necessary to use factored loads to calculate the load effects such as axial load, moment and shear then compare these to the capacity or resistance of the section. Detailed guidance on the calculation of member capacities and resistances is provided in other Sections of this publication.

1.6.3 Stability

BS 5950-1:2000 recognises three kinds of limit states for stability:

Cl. 2.4.2

Static equilibrium

The factored load should not cause any part of the structure to fail by sliding, overturning or uplift at any stage from the commencement of erection until demolition. Where the members are incapable of keeping themselves in equilibrium, sufficient bracing should be provided to maintain stability.

Cl. 2.4.2.2

Resistance to horizontal forces

The structure should be robust enough to resist horizontal forces. To ensure this, all portions of the structure, including those between expansion joints, should be able to resist a horizontal load in **all** load combinations as specified by BS 5950-1.

Cl. 2.4.2.3

- (a) In load combination 1, where wind load is not considered, the structure should be able to resist notional horizontal forces equal to 0.5% of the factored dead and imposed loads. The notional horizontal forces are applied horizontally at each floor level (Figure 1.7). This is to allow for practical imperfections such as lack of verticality and out-of-straightness.

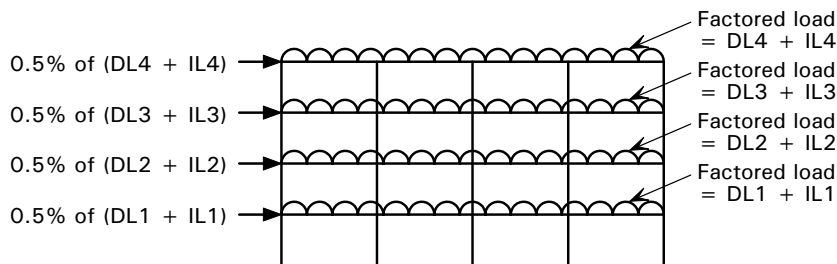


Figure 1.7 *Notional horizontal forces for use with load combination 1*

The notional horizontal forces should be applied with the vertical dead and imposed loads but should **not** be:

Cl. 2.4.2.4

- applied when considering overturning
- applied when considering pattern loads
- combined with actual horizontal loads
- combined with temperature effects
- taken to contribute to net shear on the foundations (but will effect individual foundations).

- (b) In load combinations 2 and 3 the factored wind load should not be taken as less than 1% of the factored dead load applied at each roof and floor level, as shown in Figure 1.8.

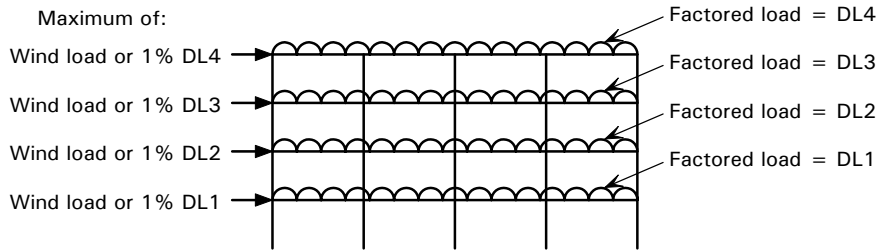


Figure 1.8 Minimum horizontal forces for load combinations 2 and 3

Resistance to horizontal forces may be provided by:

- (a) triangulated bracing members
- (b) moment resisting joints
- (c) cantilever columns, shear walls, staircase and lift shaft enclosures.

Sway stiffness

All structures should be checked to determine whether the secondary forces and moments generated by the sway of the structure are significant to the structure's stability. These second-order effects, which have not been considered in the first order analysis, are termed $P\Delta$ effects, as shown in Figure 1.9. Where secondary forces and moments are significant they should be allowed for in the design of the structure. Sufficient sway stiffness should be provided to prevent twisting of the structure on plan.

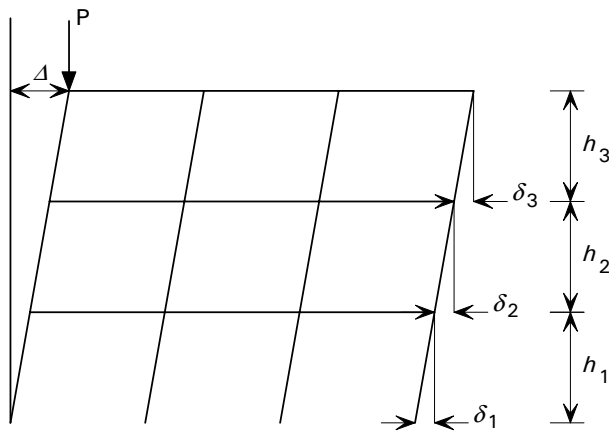


Figure 1.9 Second-order or " $P\Delta$ " effects.

Where reasonably proportioned bracing is provided in a low to medium rise structure it is likely that the $P\Delta$ effects will be insignificant, but this should be checked for all structures.

To determine whether the second-order effects are significant a value of the elastic critical load factor for the frame λ_{cr} must be calculated. The value of λ_{cr} gives a measure of the flexibility of the frame. The lower the value of λ_{cr} the more flexible the frame and hence the more susceptible it is to second-order effects. The lowest value of λ_{cr} from each storey should be adopted for the whole frame. For each storey λ_{cr} is given by:

$$\lambda_{cr} = h / 200\delta$$

where:

h is the storey height

δ is the inter-storey sway caused by the application of notional horizontal forces only (Figure 1.9).

The value of λ_{cr} calculated determines how the designer needs to take account of the second-order effects. Table 1.5 summaries the action required in three ranges for the value of λ_{cr} . Frames in which the $P\Delta$ effects can be ignored are classified as “Non-sway” otherwise the frame is “Sway sensitive”.

Table 1.5 *Designer actions in relation to $P\Delta$ effects*

| Calculated λ_{cr} | For clad structures where the stiffening effects of infill walls and cladding are ignored | | | All other structures | |
|------------------------------|---|----------------|---|----------------------|---|
| | Second-order effects | Frame type | Designer action | Frame type | Designer action |
| ≥ 10 | Insignificant | Non-sway | Ignore second-order effects | Sway sensitive | Amplify the Sway effects by k_{amp} (Cl. 2.4.2.7.b)2.). |
| < 10 and ≥ 4 | Significant | Sway sensitive | Amplify the Sway effects by k_{amp} (Cl. 2.4.2.7.b)1.). | | |
| < 4 | Very significant | | Perform a second-order elastic analysis on the frame. | | Perform a second-order elastic analysis on the frame. |

Cl. 2.4.2.6
Cl. 2.4.2.7
Cl. 2.4.2.8

Note: For a braced frame, the Sway effects are the forces in the bracing system. For other frames the Sway effects can be calculated using the method described in Clause 2.4.2.8.

For the case when sway effects need to be amplified by k_{amp} , members should be designed for the non-sway forces and moments plus the amplified sway forces and moments.

Alternatively, if resistance to horizontal forces is provided by moment connections or cantilever columns, the second-order effects can be allowed for by using the sway mode in-plane effective lengths (see Section 5.3, Table 5.2) for the columns and designing the beams to remain elastic under factored loads.

The designer must make sure that the structure and individual components remain stable. In many cases a number of designers may be involved and the code recommends that the designer ensures that there is one engineer responsible for the stability of the structure as a whole. This is also a requirement of the UK Building Regulations.

Cl. 2.1.1.2

An example showing the calculation of notional horizontal forces and λ_{cr} is presented in P326^[6]. That example highlights the load case dependence of the notional horizontal forces and therefore λ_{cr} .

1.6.4 Fatigue

As far as building structures are concerned, there will be few cases where fatigue is significant. Situations which may require fatigue checks are:

- Crane supporting structures
- Platforms carrying vibrating plant or machinery
- Slender members with wind induced oscillation - but not simply wind reversal.

BS 5950-1:2000 does not address the problem of fatigue and reference should be made to specialist literature. The relevant British Standard for fatigue is BS 7608^[7].

1.6.5 Brittle fracture

Brittle fracture is more likely to occur when steel is subjected to certain conditions such as low temperatures or high strain rates. Brittle fracture is guarded against by the selection of a suitable steel sub grade. The subject of brittle fracture and sub-grade selection is covered in detail in Section 2.3.

Cl. 2.4.4

1.6.6 Structural integrity

BS 5950-1 contains a number of rules regarding overall integrity of a structure.

Cl. 2.4.5

For all buildings it recommends that:

Buildings should be effectively tied at each principal floor and roof level. These ties should be able to resist a minimum tensile force of 75 kN. The ties will usually be provided by the beams used for normal floor loading, which can easily resist the tensile forces. Connections should be checked for tying forces.

When designing for structural integrity, gross deformations of members and connections are acceptable.

For buildings to be designed against disproportionate collapse, there are additional requirements, which can be summarised as follows:

Cl. 2.4.5.3

- (a) Ties should generally be designed for forces proportional to the floor loading. This is so that, in the event of a column failure, the beams can carry the floors in catenary action to prevent collapse of the structure.
- (b) Ties to edge columns should be able to resist a force proportional to the force in the adjacent column in case the adjacent column fails.
- (c) Columns should be carried through at each floor level unless the frame is continuous in at least one direction. Columns splices should be capable of carrying a tensile force proportional to the maximum load from any floor below down to the next splice. Again this is so that, in the event of a column failure below the splice, the splice can carry the floor below.
- (d) The bracing (or other elements resisting sway) should be sufficiently distributed throughout the building that no substantial portion of the structure is dependant on a single plane of bracing in any orthogonal direction.

- (e) Where heavy floor units are used they should be effectively anchored in the direction of the span

If any of the conditions a) to c) is not met, the building should be checked for localisation of damage. This requirement is in accordance with the Building Regulations^[8] that require that the damage is not disproportionate to the cause. i.e. the failure of a single member should not cause the collapse of the whole structure. When checking the structure with the member removed, alternative load paths should be sought and the check carried out under reduced loads and load factors. Permanent deformations within the structure are acceptable.

If an alternative load path cannot be found, the member should be designed as a key element. In this case the member should be checked for the accidental loading specified in BS 6399-1^[9]. This can be a substantial load, which is intended to allow for the effects of an explosion within the building. Thus the member should not only be able to resist the load applied from any direction, but should be able to resist the reactions from any components connected to it, up to the capacity of the component or connections.

Cl. 2.4.5.4

Summary of structural integrity provisions of BS 5950-1

Check whether the structure meets the deemed-to-satisfy requirements set out in BS 5950-1, which ensure that it is suitably braced and that there is sufficient horizontal, vertical and overall integrity:

- **Bracing:** Is there more than one system of bracing stabilizing the structure in each of two approximately orthogonal directions? Cl. 2.4.5.3d
- **Horizontal integrity:** Are there continuous lines of “ties” in two approximately orthogonal directions throughout the building at every level, and are these sufficiently strong? Cl. 2.4.5.3a

At each end of every tie, the connections (i.e. both steel and concrete connections in composite construction) need to sustain tension equal to the factored vertical reaction (or 75 kN if greater). Notionally, this requirement allows for beams to go into “catenary” when surcharged with either blast or debris loading.

- **Vertical integrity:** Can the column splices sustain sufficient tension? Cl. 2.4.5.3c
- **Overall integrity:** Are there horizontal “ties” to hold all the vertical perimeter columns in position? Cl. 2.4.5.3b

If not, then ensure that removal of either a single bracing element or any single “column” does not cause too large an area of floor to collapse. Cl. 2.4.5.3

The limit is that at a given floor/roof level not more than the lesser of 15% of the area or 70 m² of that level may collapse, together with a similar area of an immediately adjacent level.

If the floor area that is caused to collapse is greater than the limiting value, then design the relevant “columns” and bracings as key elements capable of sustaining a specified blast pressure in the accidental limit state. Cl. 2.4.5.3
Cl. 2.4.5.4

The blast pressure is specified as 34 kN/m²; as an accidental load this only requires a factor of 1.0. Notionally, this is broadly equivalent to the overpressure created in a natural gas deflagration.

In addition, check that any heavy floor units (e.g. precast planks) are sufficiently secure against dislodgement.

Note:

“Ties” can include both steel elements and concrete elements in composite construction, provided that the details interconnecting the two materials are suitable for the forces.

“Column” includes beams supporting columns.

A worked example for structural integrity is included in P326⁽⁶⁾.

1.7 Serviceability limit states

1.7.1 Deflection

A check on deflection is an essential part of design; deflection limits may govern for beams and slender structures. Deflections are usually calculated under unfactored imposed load only. This assumes that dead load deflections will be "built out" during the fabrication and erection, or that only imposed load deflections will be of significance to the occupants. Table 1.6 gives limits on deflections that are normally regarded as acceptable.

Cl. 2.5.1

Cl. 2.5.2

Table 1.6 *Suggested deflection limits*

| Deflection on beam due to unfactored imposed load | |
|---|------------------------|
| Cantilevers | Length / 180 |
| Beams carrying plaster or other brittle finish | Span / 360 |
| All other beams | Span / 200 |
| Horizontal deflection of columns (other than portal frames) due to unfactored imposed and wind load | |
| Tops of columns in single storey buildings | Height / 300 |
| In each storey of a building with more than one storey | Height of storey / 300 |
| Crane Girders | |
| Vertical deflection due to static vertical wheel loads from overhead travelling cranes | Span / 600 |
| Horizontal deflection (calculated on the top flange properties alone) due to horizontal crane loads | Span / 500 |

Table 8

A number of points should be recognised:

- The limits are those that are calculated for the bare structure. The actual deflection may be less, due to stiffening of cladding etc, but this should not be taken account of in the design
- The limits are for guidance only, and it is recognised that situations may arise where higher deflections are acceptable. In these situations the designer should use engineering judgement.
- No limits are given for portal frames for two reasons:
 - a) The stability rules given for portal frames in Section 5 of BS 5950-1 ensure that the structure will be stable even with large deflections

- b) Deflection limits require experience and judgment on the part of designer. A steel clad frame will not only deflect very much less than the bare frame (possibly less than half as much) due to the stiffness of the cladding, but the effects of deflection (depending on cladding type and details) will be minimal. However, a masonry clad structure may, depending on the way the masonry is connected, deflect nearly as much as the steel frame and the affect of large deflections on the masonry could be severe.

1.7.2 Vibration and oscillation

No guidance is given in BS 5950-1 on how vibration and oscillation should be checked. Sources of guidance include:

Cl. 2.5.3

- a) SCI publication P076 - Vibration of floors^[10]
- b) SCI advisory desk articles AD253^[11], AD254^[12] and AD256^[13]
- c) EN 1993-1 (to be published in 2004)^[14]
- d) AISC design guide code^[15]
- e) BS 6399-1: 1996^[9]

It should be noted that the correct method of solving the problem of vibration is to calculate the response of the structure. Increasing the strength of the structure may not help, it may even make the situation worse. Fortunately, in normal structures vibration is seldom a problem. Where specialist floors, such as for discos, dance halls and floors supporting vibrating machinery are to be designed, guidance may be found in BS 6399-1: 1996^[9]. If necessary further advice should be sought from either the SCI or BRE.

1.7.3 Durability

For the steelwork designer the most important form of durability that needs to be considered is resistance to corrosion.

The following factors require detailed consideration:

- The most important factor in the consideration of steel corrosion is that it can only occur in the presence of both oxygen and moisture. Thus, steel piles buried underground will not corrode below about one metre deep, because of the lack of oxygen, and steel inside a warm dry structure will not corrode, because of the lack of moisture.
- Corrosion of steel will be made significantly worse by the presence of environmental factors such as chlorides (near the coast) and sulphides (in an industrial atmosphere).
- Careful detailing can prevent the accumulation of moisture by ponding or in dirt traps.
- Unless the steelwork is exposed to view, a small amount of corrosion will not cause problems within the design life of modern building structures (25 to 50 years).
- A protective system that is applied in controlled conditions in the paint shop will be significantly better than a system applied on site, in wet windy and polluted conditions.

The current recommendations given by Corus are that internal steelwork generally requires no protection at all, except for cavity walls where special measures such as galvanizing, bitumen or coal tar epoxy coatings should be considered. More detailed information may be obtained from the Corus publications^[16].

1.8 Summary of design procedure

The sequence of design steps for a steel framed building is given below. The design steps not yet covered will be dealt with in other sections of this publication.

- | | |
|--|-----------|
| 1. Determine frame layout | |
| 2. Determine suitable method of design | Cl. 2.1.2 |
| 3. Determine loads | Cl. 2.2 |
| 4. Calculate ultimate limit state design loads | Cl. 2.4.1 |
| 5. Determine material strength | Table 9 |
| 6. Check stability and design for second-order effects | Cl. 2.4.2 |
| 7. Design members for the ultimate limit state | Section 4 |
| 8. Check structural integrity | Cl. 2.4.5 |
| 9. Check brittle fracture requirements | Cl. 2.4.4 |
| 10. Check serviceability limit states | Cl. 2.5 |

2 PROPERTIES OF STEEL

2.1 Introduction

Structural steel sections are manufactured to specific British Standards, as summarised in Table 2.1. The strength of steel used in design is based on the minimum guaranteed yield strength of steel as quoted in the appropriate British Standard.

Table 2.1 *Structural steel products*

| Product | Technical delivery requirements | | Dimensions | Tolerances |
|---|---------------------------------|-------------------------------|-------------------------------|-------------------------------|
| | Non alloy steels | Fine grain steels | | |
| Universal beams, Universal columns, Universal bearing piles | BS EN 10025 ^[17] | BS EN 10113-1 ^[18] | BS 4-1 ^[19] | BS EN 10034 ^[20] |
| Joists | | | BS 4-1 ^[19] | BS EN 10024 ^[21] |
| Parallel Flange Channels | | | BS 4-1 ^[19] | BS EN 10279 ^[22] |
| Angles | | | BS EN 10056-1 ^[23] | BS EN 10056-2 ^[23] |
| Structural tees cut from universal beams and universal columns | | | BS 4-1 ^[19] | — |
| Castellated universal beams Castellated universal columns | | | — | — |
| Hot-finished Hollow Sections | BS EN 10210-1 ^[24] | BS EN 10210-2 ^[24] | BS EN 10210-2 ^[24] | |
| Cold-formed Hollow Sections | BS EN 10219-1 ^[25] | BS EN 10219-2 ^[25] | BS EN 10219-2 ^[25] | |

Table 1
BS 5950-2:
2001

The load/extension or stress/strain characteristics of structural steel have a fundamental influence on the whole design process. If a steel specimen as shown in Figure 2.1 is tested in tension the characteristics shown in Figure 2.2 will be observed.

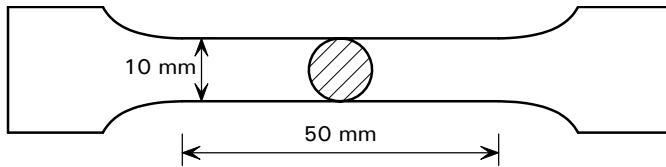


Figure 2.1 *Steel tensile specimen*

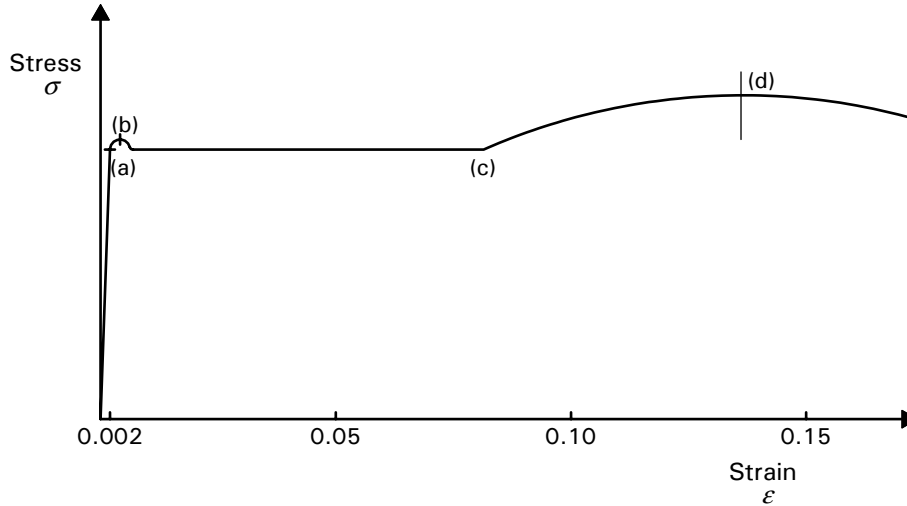


Figure 2.2 *Typical stress/strain curve*

Table 2.2 below describes each section of the curve shown in Figure 2.2 and provides additional information about structural steel grades S275 and S355.

Table 2.2 *Steel stress / strain behaviour*

| Section of curve | Description |
|------------------|--|
| 0 – a | Linear elastic behaviour. The slope of the curve is Young's modulus or the Modulus of elasticity, E. $E = \text{Stress} / \text{Strain} = 205,000 \text{ N/mm}^2$ Stress = load / area Strain = change in length / unit length. |
| a | Limit of proportionality. Yield strength, p_y of steel. For S275, p_y minimum = 275 N/mm ² For S355, p_y minimum = 355 N/mm ² |
| b | Point of upper yield, R_{eH} . This point is used as p_y for design purposes. If a definite yield point is not found the value is taken as 0.2% proof stress. The 0.2% proof stress is the stress that causes a permanent deformation of 0.2% in the material. |
| b – c | Plateau of ductility. |
| c – d | Region of strain hardening. For S275, the increase in strength is typically 20% For S355, the increase in strength is typically 10% |
| d | Ultimate tensile strength of steel (UTS). For S275, UTS minimum = 410 N/mm ² For S355, UTS minimum = 490 N/mm ² |

Cl. 3.1.3
Table 9

If steel is loaded within the elastic zone (0-a), the strain will return to zero when the load is removed and there will not be any permanent deformation. Along the plateau (b-c) the strain increases while the stress remains constant. This is an important characteristic used in both connection design and plastic analysis. At the end of the plateau there is a zone (c-d) of strain hardening and an increase in stress to the ultimate tensile strength, after which failure occurs.

Further information about the behaviour of steel subject to tension is given in Section 4.

2.2 Strength

The most common grade of steel used in design of open sections (universal beams, universal columns, angles channels and tees) is S275 steel, especially if deflection is the limiting criterion. However, S355 is generally used for composite beams because strength, rather than deflection, is often the limiting criterion. In hollow sections, the most common grade is S355 steel.

Design is usually carried out using the yield strength of the steel as obtained from Table 9 of the code and reproduced here in part as Table 2.3. The values of design strength, given in Table 2.3, decrease with thickness because during the rolling process the structure of the steel is altered and as a result the design strength improves as thickness decreases.

Table 2.3 *Design strength*

| Steel Grade | Thickness not greater than: (mm) | Design strength p_y N/mm ² |
|-------------|-------------------------------------|--|
| S275 | 16 | 275 |
| | 40 | 265 |
| | 63 | 255 |
| S355 | 16 | 355 |
| | 40 | 345 |
| | 63 | 335 |

Table 9

Clause 3.1.1 states that the design strength should be based on $1.0Y_s$ but not greater than $U_s/1.2$. (Where Y_s is the minimum yield strength and U_s is the minimum ultimate tensile strength, both from the relevant product standard). This is to ensure an adequate factor of safety against ultimate failure. The design strengths given in Table 9 of BS 5950-1 are all based on the minimum specified yield strength of the steel for the appropriate thickness. The thickness used to determine the design strength is that of the thickest element (usually the flange), the design strength is then used for the whole section.

Cl. 3.1.1

2.3 Brittle fracture

Brittle fracture is a mode of failure that is affected by the following factors:

- Low temperatures
- Thick materials
- High tensile forces (caused by external loads or residual stresses from welding or punching)

- d) Stress raisers
- e) High strain rates

BS 5950-1 reduces the risk of brittle fracture by limiting the thickness of steel that can be used in particular situations. Different steel sub-grades have different toughness and the designer can guard against brittle fracture by the selection of a sub-grade of suitable toughness for the required thickness.

Cl. 2.4.4
Table 3
Table 4
Table 5

Steel toughness is measured using a Charpy test. The Charpy test measures how much energy can be absorbed by the steel specimen, at a given temperature. The Charpy values for common steel grades are given in Table 2.4.

Table 2.4 *Typical Charpy values*

| Steel Grade | Minimum Charpy value |
|-------------|--|
| S275 | No Charpy tests performed |
| S275 JR | Charpy value of 27J can be obtained at +20 °C (Room temperature) |
| S275 J0 | Charpy value of 27J can be obtained at 0 °C |
| S275 J2 | Charpy value of 27J can be obtained at -20 °C |

Note: For structural hollow sections each of these designations is followed by an 'H', e.g. S275JOH.

The basic requirement that needs to be satisfied is:

$$t \leq K \times t_1$$

where:

- t is the thickness of the thickest element of the section (usually the flange).
- K is a factor obtained from Table 3 of BS 5950-1 and depends on the stress level, detailing and strain rate (BS 5950-1, Table 3, Note 1).
- t_1 is obtained from Table 4 or 5 of BS 5950-1 and is the maximum thickness for a given steel grade and service temperature.

Cl. 2.4.4

Table 3

Table 4

Table 5

Table 6

Table 6 of BS 5950-1 also needs to be checked to ensure the steel thickness is within the limits up to which the Charpy test is valid. This check is not usually critical but in the circumstances where the thickness is outside the limits of Table 6, additional testing is required to ensure suitable ductility.

Example 1

Select an appropriate sub-grade if S275 steel (to BS EN 10025) is used internally (minimum service temperature of -5°C). The flange thickness is 40 mm. The steel is bolted, the holes are drilled and a high tensile stress is present ($\geq 0.3Y_{nom}$).

- From Table 3 select the appropriate value of K . For a high tensile stress and drilled holes, $K = 1.5$.
- The basic requirement, $t \leq K \times t_1$ gives $40 \leq 1.5 t_1$ therefore t_1 must be ≥ 26.7 mm
- From Table 4, for a minimum service temperature of -5° grade S275 JR has $t_1 = 30$ mm and therefore satisfies the basic requirement.

Table 3

Table 4

BS 5950-1

- From Table 6 the maximum thickness for a BS EN 10025 section is 100 mm.

Table 6

A section to BS EN 10025 S275 JR will satisfy the requirements.

Example 2

As example 1 but the steel is welded rather than bolted.

- From Table 3 select the appropriate value of K . For a high tensile stress and welded generally, $K = 1.0$.
- The basic requirement, $t \leq K \times t_1$ gives $40 \leq 1.0 t_1$ therefore, t_1 must be ≥ 40 mm
- From Table 4, for a minimum service temperature of -5° grade S275 J0 has $t_1 = 65$ mm and therefore satisfies the basic requirement.
- From Table 6 the maximum thickness for a BS EN 10025 section is 100 mm.

Table 3

Table 4

Table 6

A section to BS EN 10025 S275 J0 will satisfy the requirements.

Example 3

As example 2 but the minimum service temperature is -25°C .

- From Table 3, $K = 1.0$ as example 2.
- The basic requirement, $t \leq K \times t_1$ gives $40 \leq 1.0 t_1$ therefore, t_1 must be ≥ 40 mm
- From Table 4, for a minimum service temperature of -25° grade S275 J2 has $t_1 = 65$ mm and therefore satisfies the basic requirement.
- From Table 6 the maximum thickness for a BS EN 10025 section is 100 mm.

Table 3

Table 4

Table 6

A section to BS EN 10025 S275 J2 will satisfy the requirements.

3 LOCAL BUCKLING AND SECTION CLASSIFICATION

3.1 Introduction

Buckling is a phenomenon that affects all thin materials when subjected to a compressive force. In structural members that comprise wide, thin plate elements local buckling of those elements can occur before the member develops the full material strength (i.e. its yield strength). A typical pattern of local buckling in the thin flange of a beam in bending is shown in Figure 3.1. When local buckling occurs it limits the load carrying capability of the section and therefore local buckling must be considered in the design.

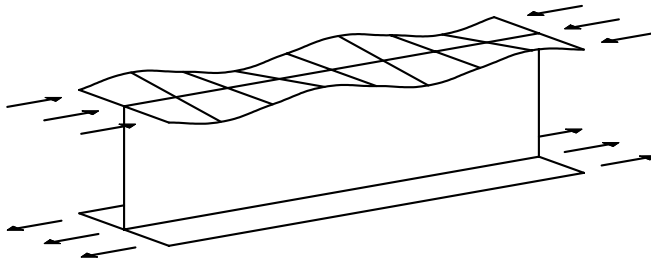


Figure 3.1 Typical pattern of local buckling in a thin flange

3.2 Section classification

BS 5950-1 uses a system of cross-section classification to take account of local buckling when determining section capacity. The classification of each compression element of the section is determined and the section as a whole is assigned the classification of the least favourable element. Throughout BS 5950-1 the member capacity design rules are dependent on the section classification of the member.

Cl. 3.5.1

The susceptibility to local buckling of a compression element is dependent on:

- Element geometry (width/thickness ratio)
- Stress distribution
- Support conditions
- Yield strength, p_y

Elements with high width/thickness ratios are more likely to suffer from local buckling, as are elements subject to uniform compressive stress.

For most sections there are two types of element to consider, the flange and the web. The elements of a cross-section will either be:

- (a) External elements, attached to an adjacent element along one edge only, the other edge being free e.g. the flange of a UB
- (b) Internal elements, attached to other elements along both longitudinal edges e.g. the web of a UB

Figure 5 of BS 5950-1 defines the various elements in a number of cross-sections. Dimensions of compression elements of universal beams, hot-finished hollow sections and cold-formed hollow sections are shown in Figure 3.2.

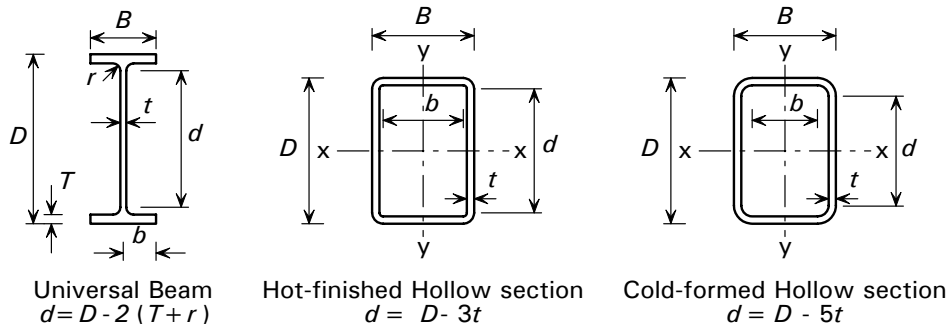


Figure 3.2 Dimensions of compression elements

The four classes of cross-section given in the code are described below. For a typical beam, the moment / rotation characteristics are shown in Figure 3.3.

Cl. 3.5.2

Class 1 Plastic

Sections in which all elements subject to compression are relatively stocky (small width to thickness ratios) and which can develop the full plastic moment capacity with sufficient rotation capacity to allow redistribution of moments within the structure. Only Class 1 plastic sections should be used at plastic hinge locations in structures where rotation is required.

Class 2 Compact

Sections in which the elements in compression are less stocky, but which can develop the full plastic moment capacity. However, local buckling of the section will prevent development of a plastic hinge with sufficient rotation capacity to allow redistribution of moments. Class 2 compact sections should not be used at plastic hinge locations where rotation is required.

Class 3 Semi-compact

Sections in which the design strength p_y can be attained at the extreme fibres but local buckling will prevent the development of the full plastic moment capacity. The moment capacity of Class 3 semi-compact sections will be between the plastic moment and the elastic moment capacity.

Class 4 Slender

Sections in which elements subject to compression are slender and in which local buckling will prevent the stress in the section from reaching the design strength, based on gross section properties and elastic stress distribution. The moment capacity of a Class 4 slender section is less than the elastic moment capacity of the gross section.

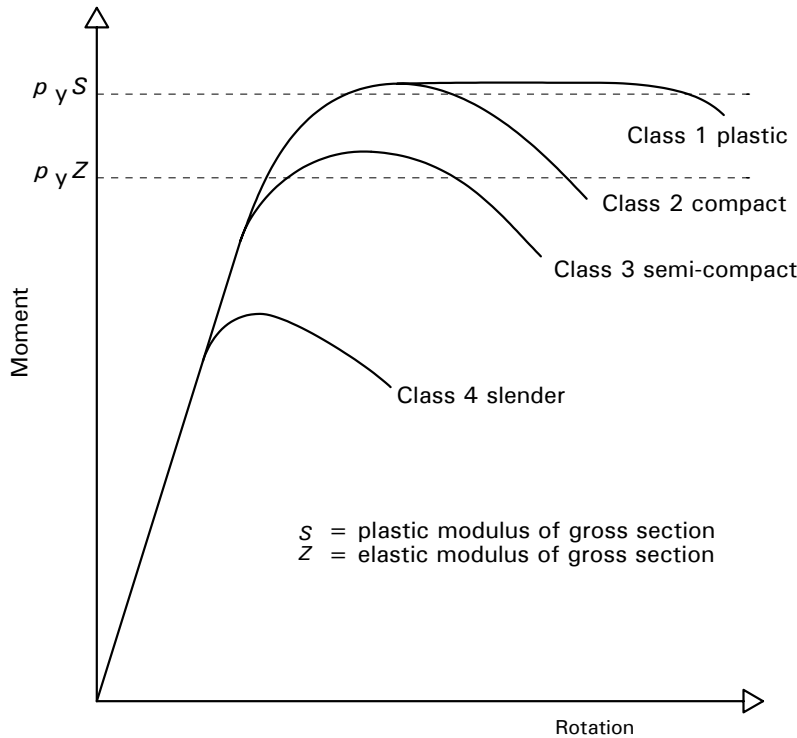


Figure 3.3 *Moment / rotation behaviour for different section classes*

The classification of cross-sections is carried out according to the limiting values provided in Tables 11 and 12 of BS 5950-1:2000. If the b/t or the d/t limit for a Class 3 semi-compact element is exceeded, then the element is Class 4 slender. Tables 11 and 12 are reproduced in part as Table 3.1 and Table 3.2.

Table 3.1 *Limiting width to thickness ratios for I and H sections*

| Compression Element | | Ratio | Limiting Values | | |
|---|--|-------|----------------------------|--------------------------------|------------------------------|
| | | | Class 1 Plastic | Class 2 Compact | Class 3 Semi-compact |
| Outstand element of compression flange | Rolled section | b/T | 9ϵ | 10ϵ | 15ϵ |
| Web | | d/t | 80ϵ | 100ϵ | 120ϵ |
| Neutral axis at mid depth | | | | | |
| Web | | d/t | $\frac{80\epsilon}{1+r_1}$ | $\frac{100\epsilon}{1+1.5r_1}$ | $\frac{120\epsilon}{1+2r_2}$ |
| Generally | If r_1 is positive i.e. compression | | but $\geq 40\epsilon$ | but $\geq 40\epsilon$ | but $\geq 40\epsilon$ |

Table 3.2 Limiting width to thickness ratios for hot-finished RHS

| Compression Element | Ratio | Limiting Values | | |
|---------------------|----------------------------|--------------------|---|--|
| | | Class 1 Plastic | Class 2 Compact | Class 3 Semi-compact |
| Flange | Axial compression | b/t | Not applicable | 40ε |
| | Compression due to bending | b/t | 28ε $\leq 80\varepsilon - d/t$ | 32ε $\leq 62\varepsilon - 0.5d/t$ |
| Web | Neutral axis at mid depth | d/t | 64ε | 80ε |
| Web Generally | If r_2 is positive | d/t | $\frac{64\varepsilon}{1+0.6r_1}$ | $\frac{80\varepsilon}{1+r_1}$ |
| | | | but $\geq 40\varepsilon$ | but $\geq 40\varepsilon$ |
| | | | $\frac{120\varepsilon}{1+2r_2}$ | but $\geq 40\varepsilon$ |

The following are general notes for Tables 3.1 and 3.2.

The parameter $\varepsilon = (275/p_y)^{0.5}$ is used to accommodate varying design strengths.

The stress ratios r_1 and r_2 allow for the level of applied axial load F_c in relation to web strength.

$$\text{For I and H sections; } r_1 = \frac{F_c}{dtp_{yw}} \text{ but } -1 < r_1 \leq 1 \text{ and } r_2 = \frac{F_c}{A_g p_{yw}}$$

$$\text{For hollow sections; } r_1 = \frac{F_c}{2dtp_{yw}} \text{ but } -1 < r_1 \leq 1 \text{ and } r_2 = \frac{F_c}{A_g p_{yw}}$$

where:

F_c is the applied axial load (taken as positive for compression)

p_{yw} is the design strength of the web

A_g is the gross area of the cross-section

The limits on slenderness for the flanges of rectangular hollow sections (b/t) take account of the slenderness of the web (d/t).

The classification of cross-sections has implications on the design of the member. These implications will be dealt with in detail in following Sections.

The lower limit of 40ε for the web generally case in Tables 3.1 and 3.2 corresponds to the limit that would be obtained if the section were fully stressed. Therefore, for the web generally case 40ε may be taken as a conservative limit without the need to calculate the values of r_1 or r_2 .

General Guidance

All hot rolled I and H sections to BS 4^[19] in grade S275, and most in grade S355 are classified as Class 2 compact or better when in pure bending. The exceptions are shown in Table 3.3. No hot rolled I and H sections are Class 4 slender under pure bending.

Table 3.3 *I and H sections to BS 4 that are Class 3 semi-compact under pure bending*

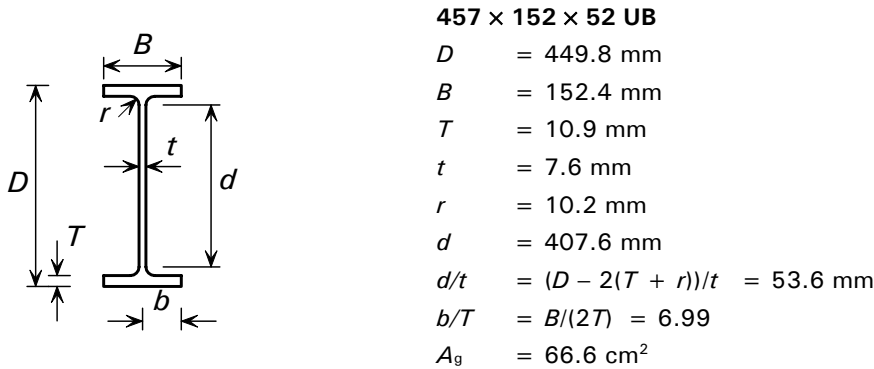
| Section | Grade S275 | Grade S355 |
|-------------------|-----------------------------------|-----------------|
| Universal Beams | None | 356 × 171 × 45 |
| Universal Columns | 356 × 368 × 129 152 × 152 × 23 | 356 × 368 × 153 |
| | | 356 × 368 × 129 |
| | | 305 × 305 × 97 |
| | | 254 × 254 × 73 |
| | | 203 × 203 × 46 |
| 152 × 152 × 23 | | |
| Joists | None | None |

Capacity tables given in P202^[26] give the section classification for both the flanges and webs of most structural sections in grades S275 and S355 for a variety of loading conditions.

3.3 Section classification examples

Example 1

Consider a 457 × 152 × 52 Universal Beam, grade S275, subject to bending.



Page B-4
ref. 26

Figure 3.4 *Universal beam dimensions*

The flange thickness, T is less than 16 mm, therefore $p_y = 275$ N/mm².

$$\epsilon = \sqrt{\frac{275}{p_y}} = \sqrt{\frac{275}{275}} = 1.0$$

The b/T limit for a Class 1 plastic, rolled flange is $9\epsilon = 9.0$, which is greater than the section b/T . Therefore, the flange is Class 1 plastic.

The section is symmetric about the axis of bending and therefore the neutral axis is at mid-depth. The limit for a Class 1 plastic, rolled web with the neutral axis at mid-depth is $80\epsilon = 80$, which is greater than 53.6. Therefore, the web is Class 1 plastic.

Both the flange and the web are Class 1 plastic. Therefore, the section is Class 1 plastic when subject to bending.

Table 9

Table 9
note b

Example 2

Consider the same beam (457 × 152 × 52 S275) subject to an axial compressive load of 800 kN and a bending moment about the major axis.

As in Example 1, $\varepsilon = 1.0$.

The limit for a Class 1 plastic, rolled flange is $9\varepsilon = 9.0$, which is greater than b/T . Therefore, the flange is Class 1 plastic.

Table 11

The section is subject to axial load and bending, therefore the neutral axis is not at mid-depth. The d/t limit for a Class 1 plastic, rolled web generally is,

Table 11

$$\frac{80\varepsilon}{1+r_1} \text{ but } \geq 40\varepsilon \quad \text{where } r_1 = \frac{F_c}{d t p_{yw}} = \frac{800 \times 10^3}{407.6 \times 7.6 \times 275} = 0.94$$

$$\text{The } d/t \text{ limit } \frac{80\varepsilon}{1+r_1} = \frac{80 \times 1.0}{1+0.94} = 41.2 < 53.6$$

Therefore, the web is not Class 1 plastic.

The d/t limit for a Class 2 compact, rolled web generally is,

Table 11

$$\frac{100\varepsilon}{1+1.5r_1} = \frac{100 \times 1.0}{1+1.5 \times 0.94} = 41.5 < 53.6$$

Therefore, the web is not Class 2 compact,

The d/t limit for a Class 3 semi-compact, rolled web generally is,

Table 11

$$\frac{120\varepsilon}{1+2r_2} \text{ where } r_2 = \frac{F_c}{A_g p_{yw}} = \frac{800 \times 10^3}{66.6 \times 10^2 \times 275} = 0.44$$

$$\text{Hence, } \frac{120\varepsilon}{1+2r_2} = \frac{120 \times 1.0}{1+2 \times 0.44} = 63.8 > d/t$$

Therefore, the web is Class 3 semi-compact.

The section therefore has a Class 3 semi-compact web and a Class 1 plastic flange and should be treated as a Class 3 semi-compact section.

If the axial load were increased to 1500 kN it could be shown that the web, and therefore the section, becomes Class 4 slender.

Example 3

Consider a $250 \times 150 \times 5.0$ hot-finished rectangular hollow section grade S355, subject to bending about its major axis.

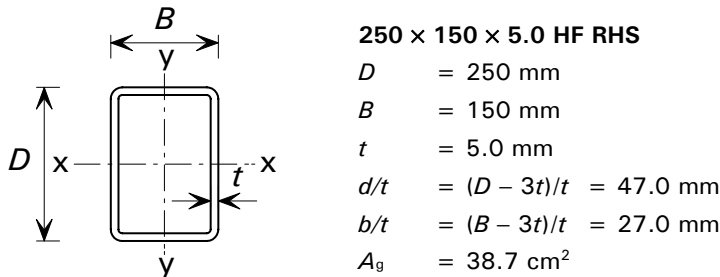


Figure 3.5 Hot finished rectangular hollow section

The wall thickness, t is less than 16 mm therefore $p_y = 355$ N/mm².

Table 9

$$\varepsilon = \sqrt{\frac{275}{p_y}} = \sqrt{\frac{275}{355}} = 0.88$$

The b/t limit for a Class 1 plastic hot-finished flange is 28ε but $\leq 80\varepsilon - d/t$.

Table 12

$$28\varepsilon = 24.6 \quad \text{and} \quad 80\varepsilon - d/t = 23.4$$

Therefore, the b/t limit for a Class 1 plastic flange is 23.4, which is less than 27. Therefore, the flange is not Class 1 plastic.

The b/t limit for a Class 2 compact hot-finished flange is 32ε but $\leq 62\varepsilon - 0.5d/t$.

Table 12

$$32\varepsilon = 28.2 \quad \text{and} \quad 62\varepsilon - 0.5d/t = 31.1$$

Therefore, the b/t limit for a Class 2 compact flange is 28.2, which is greater than 27. Therefore, the flange is Class 2 compact.

The d/t limit for a Class 1 plastic hot-finished web with the neutral axis at mid-depth is $64\varepsilon = 56.3$, which is greater than 47. Therefore, the web is Class 1 plastic.

Table 12

The section is Class 2 compact when subject to pure bending.

Example 4

Consider the same HF RHS ($250 \times 150 \times 5.0$ S355) subject to a compressive axial load of 1100 kN and a bending moment about the major axis.

The flange classification limits are the same as in Example 3. Hence, the flange is Class 2 compact.

Table 12

The web is unlikely to be Class 1 plastic with the section subject to 1100 kN of axial load. Therefore, check the Class 2 compact limit.

The d/t limit for a Class 2 compact hot-finished web generally is,

$$\frac{80\varepsilon}{1+r_1} \text{ but } \geq 40\varepsilon \text{ where } r_1 = \frac{F_c}{2 d t p_{yw}} \text{ but } -1 < r_1 \leq 1$$

As in Example 3, ε equals 0.88.

$$r_1 = \frac{1100 \times 10^3}{2 \times 235 \times 5.0 \times 355} = 1.32 > 1 \text{ therefore take } r_1 = 1.0.$$

$$\text{The Class 2 compact } d/t \text{ limit} = \frac{80\varepsilon}{1+r_1} = \frac{80 \times 0.88}{1+1} = 35.2$$

but $\geq 40\varepsilon = 35.2$.

The web d/t equals 47, which is greater than the limit of 35.2, therefore the web is not Class 2 compact.

The d/t limit for a Class 3 semi-compact web is,

$$\frac{120\varepsilon}{1+2r_2} \text{ but } \geq 40\varepsilon \text{ where } r_2 = \frac{F_c}{A_g p_{yw}}$$

$$r_2 = \frac{1100 \times 10^3}{38.7 \times 10^2 \times 355} = 0.80.$$

$$\text{The Class 3 semi-compact } d/t \text{ limit} = \frac{120\varepsilon}{1+2r_2} = \frac{120 \times 0.88}{1+2 \times 0.8} = 40.6 < 47$$

Therefore, the web is Class 4 slender.

The section therefore has a Class 2 compact flange and a Class 4 slender web when subject to an axial load of 1100 kN. In these circumstances the section is Class 4 slender.

3.4 Effective section properties

3.4.1 Class 3 Semi-compact sections

As shown in Figure 3.3 the moment capacity of a Class 3 semi-compact section will lie between the elastic moment capacity ($p_y Z$) and the plastic moment capacity ($p_y S$). The moment capacity of a Class 3 semi-compact section can be conservatively taken as the elastic moment capacity, which equals $p_y Z$. Alternatively, a more accurate moment capacity ($p_y S_{\text{eff}}$) may be calculated by determining an effective plastic modulus (S_{eff}).

Cl. 3.5.6

The code gives formulae for calculating S_{eff} for various sections. For an I or H section with equal flanges the formulae are given as:

$$S_{x,\text{eff}} = Z_x + (S_x - Z_x) \left[\frac{\left(\frac{\beta_{3w}}{d/t} \right)^2 - 1}{\left(\frac{\beta_{3w}}{\beta_{2w}} \right)^2 - 1} \right] \quad \text{but} \quad S_{x,\text{eff}} \leq Z_x + (S_x - Z_x) \left[\frac{\frac{\beta_{3f}}{b/T} - 1}{\frac{\beta_{3f}}{\beta_{2f}} - 1} \right]$$

$$S_{y,\text{eff}} = Z_y + (S_y - Z_y) \left[\frac{\frac{\beta_{3f}}{b/T} - 1}{\frac{\beta_{3f}}{\beta_{2f}} - 1} \right]$$

Cl. 3.5.6.2

where:

- β_{2f} is the limiting value of b/T for a Class 2 compact flange
- β_{2w} is the limiting value of d/t for a Class 2 compact web
- β_{3f} is the limiting value of b/T for a Class 3 semi-compact flange
- β_{3w} is the limiting value of d/t for a Class 3 semi compact web
- S_x and S_y are the plastic moduli
- Z_x and Z_y are the elastic moduli

Similar formulae are also given for rectangular hollow sections and circular hollow sections.

Cl. 3.5.6.3

Cl. 3.5.6.4

3.4.2 Class 4 slender sections

For Class 4 slender sections there are two effective section properties that may need to be calculated, the effective area and the effective elastic modulus.

Cl. 3.6

Effective Area

The effective area is used in determining the compression resistance of a Class 4 slender section (see Section 5.1).

Cl. 3.6.2.2

The effective area is calculated by disregarding those parts of the cross-section that are more susceptible to local buckling, i.e. those parts that will be ineffective when highly stressed. BS 5950-1, Figure 8a (which is reproduced in part here as Figure 3.6) shows those parts (shaded) of slender sections that are to be disregarded.

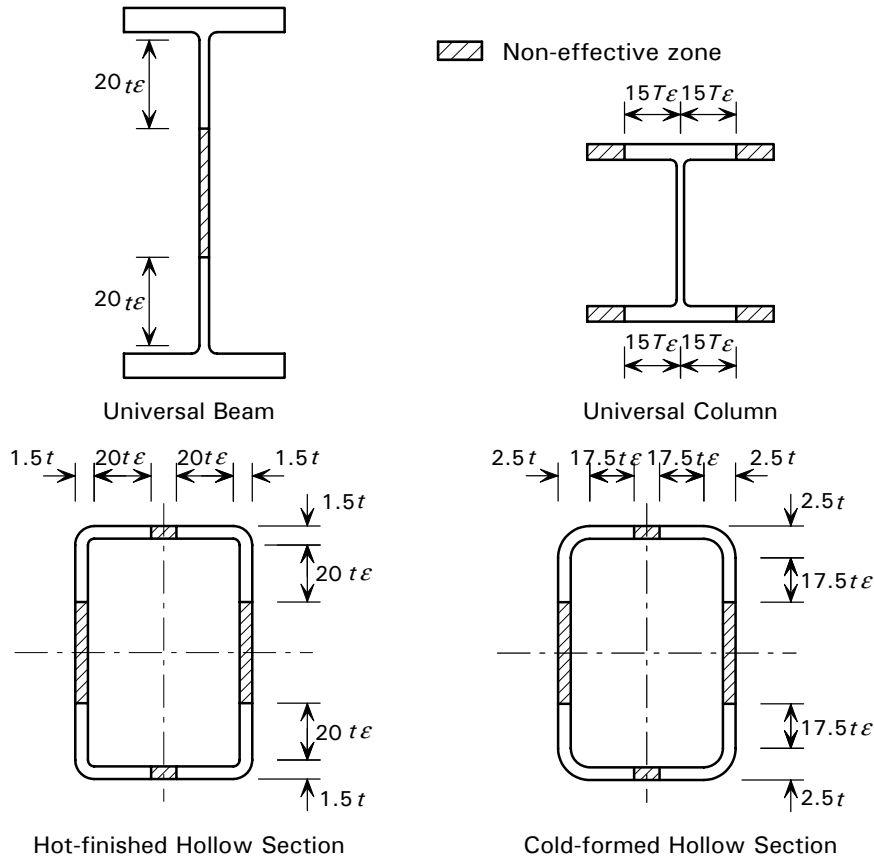


Figure 3.6 *Effective cross-section under pure compression for determining A_{eff}*

Effective Elastic Modulus

The effective elastic modulus is used in determining the moment capacity of a Class 4 slender section (see Section 6.5). Similarly to the effective area calculation, the effective elastic modulus is calculated by disregarding those parts of the cross-section that are more susceptible to local buckling.

Table 3.4 summaries the various cases to consider for calculating the effective elastic modulus and describes how the effective elastic modulus should be calculated for a doubly symmetric section.

Table 3.4 Summary of effective elastic modulus calculation

| | Section subject to bending | | Section subject to axial load and bending | |
|--|---|-------------------------|---|-------------------------|
| | Flange slender | Flange not slender | Flange slender | Flange not slender |
| Web slender under pure bending | Use Figure 8b for flange. Use Figure 9 for web. | Use Figure 9 for web. | Use Figure 8b for flange. Use Figure 9 for web. | Use Figure 9 for web. |
| Web only slender under combined axial load & bending | n/a | n/a | Use Figure 8b for flange. Treat web as fully effective. | Z_{eff} equals Z . |
| Web not slender under pure bending | Use Figure 8b for flange. | Z_{eff} not required. | Use Figure 8b for flange. | Z_{eff} not required. |

Notes: Figure 8b of BS 5950-1 is reproduced in part here as Figure 3.7.
 Figure 9 of BS 5950-1 is reproduced in part here as Figure 3.8.

When the webs are fully effective, the shaded parts of the flanges shown in Figure 3.7 are ineffective and should be disregarded when calculating the effective elastic modulus.

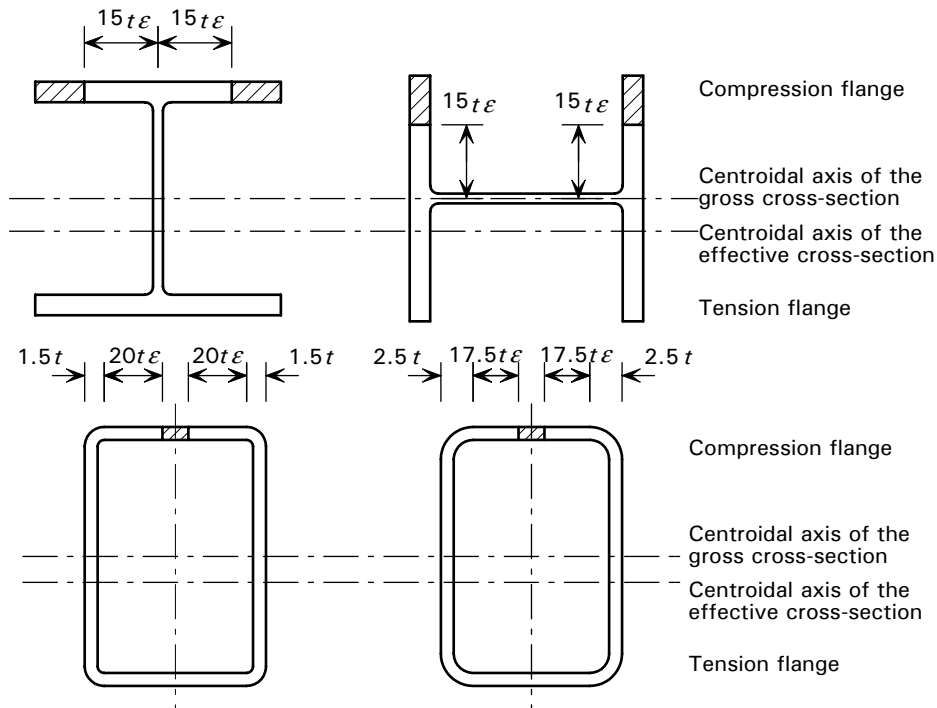


Figure 8b

Figure 3.7 Effective cross-section, webs fully effective under pure moment, for determining Z_{eff}

If the web is slender under pure bending an ineffective portion of the web needs to be determined as shown in Figure 3.8. An iterative process can be used to determine the ineffective portion of the web because the size of the ineffective portion is dependent on the position of the elastic neutral axis of the effective section, which is in turn dependent on the size of the ineffective portion of the web. Figure 3.8 shows that the size and the position of the ineffective portion of the web is dependent on the effective width of the compression zone, b_{eff} . Where b_{eff} is given by:

$$b_{\text{eff}} = \frac{120 \varepsilon t}{\left[1 + \frac{f_{\text{cw}} - f_{\text{tw}}}{p_{\text{yw}}} \right] \left[1 + \frac{f_{\text{tw}}}{f_{\text{cw}}} \right]}$$

where:

- f_{cw} is the maximum compressive stress in the web subject to pure bending (should always be taken as positive)
- f_{tw} is the maximum tensile stress in the web subject to pure bending (should always be taken as positive)
- p_{yw} is the design strength of the web
- t is the web thickness.

The expression for b_{eff} simplifies to $60t\varepsilon$ for a doubly symmetric sections subject to pure bending.

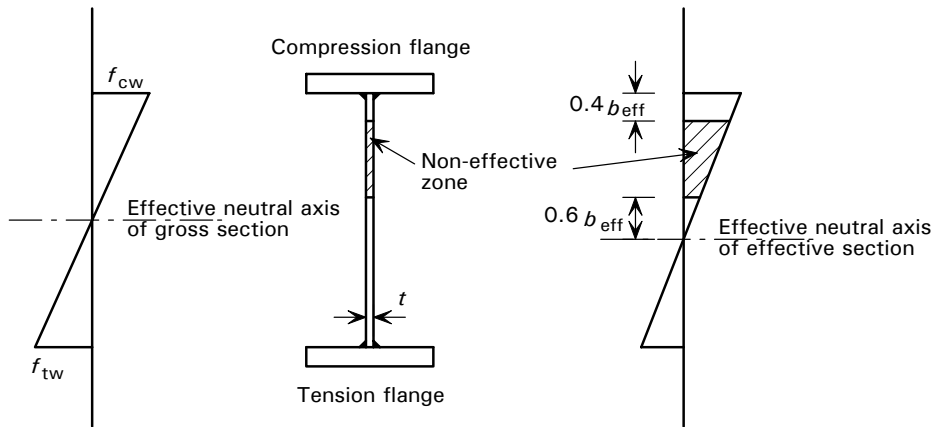


Figure 9

Figure 3.8 *Effective width for slender web under pure bending*

When calculating effective properties for Class 4 slender sections which are subject to axial load and bending, each of the load effects should be considered separately, i.e. the effective area should be calculated assuming the section is subject to axial load only, the effective modulus about the major axis should be calculated assuming the section is subject to bending about the major axis only and the effective modulus about the minor axis should be calculated assuming the section is subject to bending about the minor axis only.

Singly symmetric and unsymmetric sections

Effective properties of singly symmetric and unsymmetric sections are also calculated by disregarding the parts of the cross-section that are more susceptible to local buckling. However, account must be taken of the additional moments that are induced as a result of the shift in centroid of the effective section. Alternatively, the method of using a reduced design strength may be employed (described below), which avoids the need to consider additional moments.

Cl. 3.6.3

Reduced design strength

As an alternative to calculating effective section properties for Class 4 slender sections, a reduced design strength p_{yr} can be calculated (in accordance with Clause 3.6.5) for which the cross-section would be Class 3. The reduced strength can be used with the gross section properties. This approach can be simpler than calculating effective section properties but can lead to conservative results.

Cl. 3.6.5

3.5 Examples of effective section property calculation**Example 1**

Consider the $457 \times 152 \times 52$ UB S275 from Example 2, Section 3.3. The section is Class 3 semi-compact when subject to a compressive axial load of 800 kN and a bending moment. Therefore, the effective plastic modulus $S_{x,\text{eff}}$ is required.

The effective plastic modulus about the major axis is obtained from:

$$S_{x,\text{eff}} = Z_x + (S_x - Z_x) \left[\frac{\left(\frac{\beta_{3w}}{d/t} \right)^2 - 1}{\left(\frac{\beta_{3w}}{\beta_{2w}} \right)^2 - 1} \right] \quad \text{but} \quad S_{x,\text{eff}} \leq Z_x + (S_x - Z_x) \left[\frac{\frac{\beta_{3f}}{b/T} - 1}{\beta_{2f} - 1} \right]$$

Cl. 3.5.6.2

For a $457 \times 152 \times 52$ UB, $Z_x = 950 \text{ cm}^3$, $S_x = 1100 \text{ cm}^3$, $d/t = 53.6 \text{ mm}$ and $b/T = 6.99 \text{ mm}$.

From Example 2, Section 3.3;

$$\beta_{3w} = \frac{120\varepsilon}{1 + 2r_2} = \frac{120 \times 1.0}{1 + 2 \times 0.44} = 63.8$$

$$\beta_{2w} = \frac{100\varepsilon}{1 + 1.5r_1} = \frac{100 \times 1.0}{1 + 1.5 \times 0.94} = 41.5$$

$$\beta_{3f} = 15\varepsilon = 15 \times 1.0 = 15$$

$$\beta_{2f} = 10\varepsilon = 10 \times 1.0 = 10$$

$$S_{x,\text{eff}} = 950 + (1100 - 950) \left[\frac{\left(\frac{63.8}{53.6} \right)^2 - 1}{\left(\frac{63.8}{41.5} \right)^2 - 1} \right] = 950 + 150 \left[\frac{0.417}{1.36} \right] = 996 \text{ cm}^3$$

$$\text{but } S_{x,\text{eff}} \leq 950 + (1100 - 950) \left[\frac{\frac{15}{6.99} - 1}{\frac{15}{10} - 1} \right] = 950 + 150 \left[\frac{1.15}{0.5} \right] = 1295 \text{ cm}^3$$

Table 11

Therefore, the effective plastic modulus $S_{x,\text{eff}} = 996 \text{ cm}^3$.

Example 2

Consider the $250 \times 150 \times 5.0$ hot-finished RHS grade S355 from Example 4, Section 3.3, subject to a compressive axial load of 1100 kN and a bending moment.

In Example 4, Section 3.3, the section has been shown to have a Class 2 compact flange and a Class 4 slender web. Therefore, the effective area A_{eff} and effective elastic modulus $Z_{x,\text{eff}}$ are required.

The effective area should be taken as shown in Figure 8a of the code and Figure 3.6 and Figure 3.9 of this publication. Only the webs are Class 4 slender and therefore only the webs have ineffective zones.

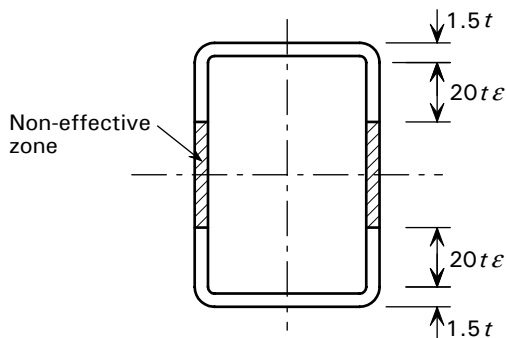


Figure 3.9 Effective cross-section for determining A_{eff}

The effective width of the web for each web is taken as,

$$2(20t\epsilon + 1.5t) = 2(20 \times 5 \times 0.88 + 1.5 \times 5) = 191 \text{ mm}$$

The ineffective length of each web is, $D - 40t\epsilon = 250 - 191 = 59 \text{ mm}$

The ineffective area of each web is, $59 \times 5 = 295 \text{ mm}^2$

The gross area of the section, $A_g = 38.7 \text{ cm}^2$

The total effective area, $A_{\text{eff}} = A_g - 2 \times 295 \times 10^{-2} = 38.7 - 5.9 = 32.8 \text{ cm}^2$

Example 3

Consider the fabricated section grade S275 shown in Figure 3.10 subject to pure bending. The flanges are Class 1 plastic but the web is Class 4 slender. Therefore, the effective elastic modulus is required.

To determine the effective elastic modulus, the effective width b_{eff} of the compression zone of the web must be calculated.

For a doubly symmetric section subject to pure bending, b_{eff} equals 60ϵ . Therefore, for the section in Figure 3.10, $b_{\text{eff}} = 60 \times 1.0 \times 8 = 480 \text{ mm}$.

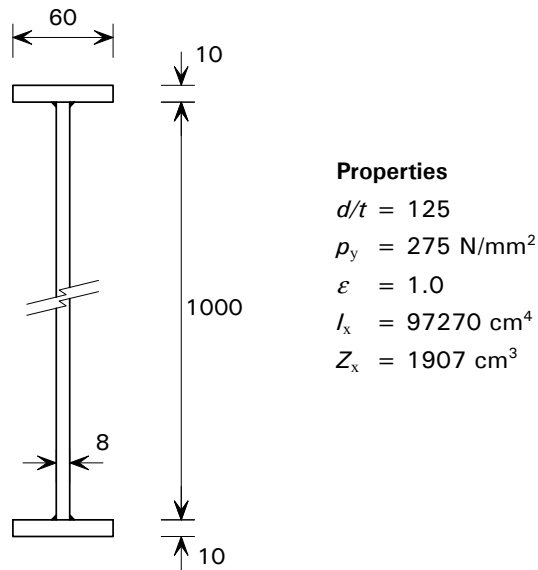


Figure 3.10 Fabricated section with Class 4 slender web

As explained in Section 3.4.2, determining the effective properties of the web is an iterative process. The two unknowns are the size of the ineffective zone x and the position of the neutral axis from the bottom of the web y_{bar} (see Figure 3.11).

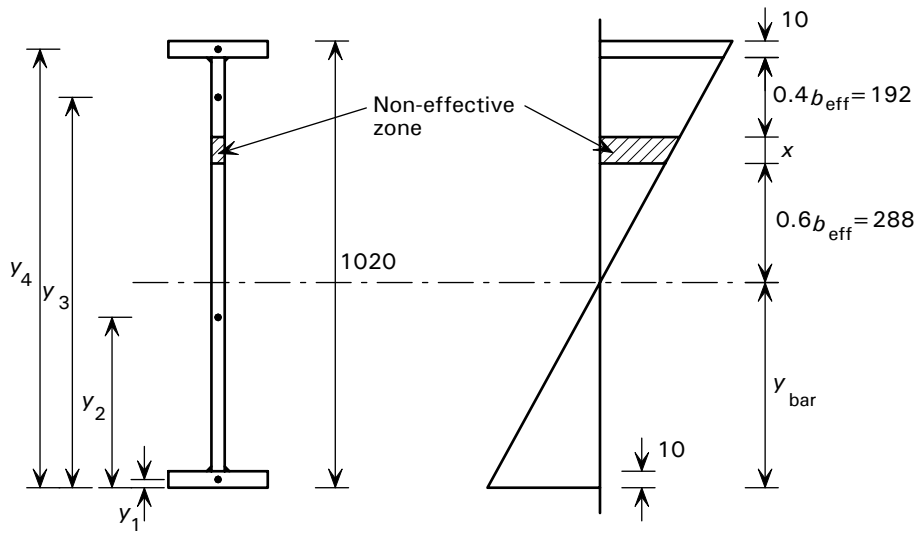


Figure 3.11 Ineffective zone of the fabricated section

The d/t Class 3 semi-compact limit for a web with the neutral axis at mid-depth is 120ϵ . The d/t of the fabricated section is 125, therefore try x equal to $5t$, which is 40 mm.

Table 11

$$\begin{aligned}
 y_{\text{bar}} &= \frac{\sum(y \times a)}{A_{\text{eff}}} \\
 &= \frac{5 \times 60 \times 10 + (10 + 384) \times 768 \times 8 + (10 + 904) \times 192 \times 8 + 1015 \times 60 \times 10}{1000 \times 8 + 2 \times 60 \times 10 - 40 \times 8} \\
 &= \frac{3000 + 2421000 + 1404000 + 609000}{8880} \\
 &= 500 \text{ mm}
 \end{aligned}$$

Check if $y_{\text{bar}} + x + b_{\text{eff}} + 10$ equals 1020 mm,

$$500 + 40 + 480 + 10 = 1030 \text{ mm} > 1020 \text{ mm}$$

Therefore, reduce x value by slightly more than 10 mm, try $x = 28$ mm.

$$\begin{aligned}
 y_{\text{bar}} &= \frac{\sum(y \times a)}{A_{\text{eff}}} \\
 &= \frac{3000 + (10 + 390) \times 780 \times 8 + 1404000 + 609000}{1000 \times 8 + 2 \times 60 \times 10 - 28 \times 8} \\
 &= \frac{5412000}{8976} = 503 \text{ mm}
 \end{aligned}$$

Check if $y_{\text{bar}} + x + b_{\text{eff}} + 10$ equals 1020 mm,

$$503 + 28 + 480 + 10 = 1021 \text{ mm} \approx 1020 \text{ mm}$$

Therefore, the length of the ineffective zone of the web is 28 mm.

$$\begin{aligned}
 I_{x,\text{eff}} &= \left(\frac{BD^3}{12} + an^2 \right)_{\text{Whole web}} - \left(\frac{BD^3}{12} + an^2 \right)_{\text{Ineffective web}} + \left(\frac{BD^3}{12} + an^2 \right)_{\text{Flanges}} \\
 &= \left(\frac{8 \times 1000^3}{12} + 8000 \times 7^2 \right) - \left(\frac{8 \times 28^3}{12} + 28 \times 8 \times 302^2 \right) + \dots \\
 &\quad \dots + \left(\frac{60(1020^3 - 1000^3)}{12} + 2 \times 60 \times 10 \times 7^2 \right)
 \end{aligned}$$

$$\begin{aligned}
 I_{x,\text{eff}} &= 667 \times 10^6 - 20.4 \times 10^6 + 306 \times 10^6 \\
 &= 952.6 \times 10^6 \text{ mm}^4 = 95260 \text{ cm}^4
 \end{aligned}$$

$$Z_{x,\text{eff}} = \frac{I_{x,\text{eff}}}{1020 - y_{\text{bar}}} = \frac{95260}{(1020 - 503)/10} = 1840 \text{ cm}^4$$

3.6 Summary of design procedure

1. Select section type and size.
2. Select steel grade.
3. Determine the classification of each element of the section for the design loadings. Determine the overall section classification.

Table 11

Table 12

BS 5950-1

4. For Class 1 plastic and Class 2 compact sections, calculate gross section properties.
5. For Class 3 semi-compact sections subject to bending calculate the effective plastic modulus.
6. For Class 4 slender sections subject to bending calculate the effective elastic modulus.
7. For Class 4 slender sections subject to compressive axial load calculate the effective area.

4 TENSION MEMBERS

4.1 Introduction

The design of tension members is generally straightforward. Tension capacity is determined by:

- Material properties
- The presence of holes
- Connection eccentricity.

For the case where tensile load is applied along the centroidal axis, the tension capacity is given by:

$$P_t = A_e \times p_y$$

Cl 4.6.1

where:

A_e is the effective area of the member cross-section

p_y is the member design strength

The allowance for holes in determining the effective area and the design of eccentrically loaded members are discussed below.

4.2 Material properties

Figure 4.1 is a simplified stress strain curve for ductile structural steel showing a clearly defined yield point, a plateau of ductility and an increase in strength due to strain hardening before final failure by fracture. In most design situations the design strength is simply based on the yield strength, as given in Table 9.

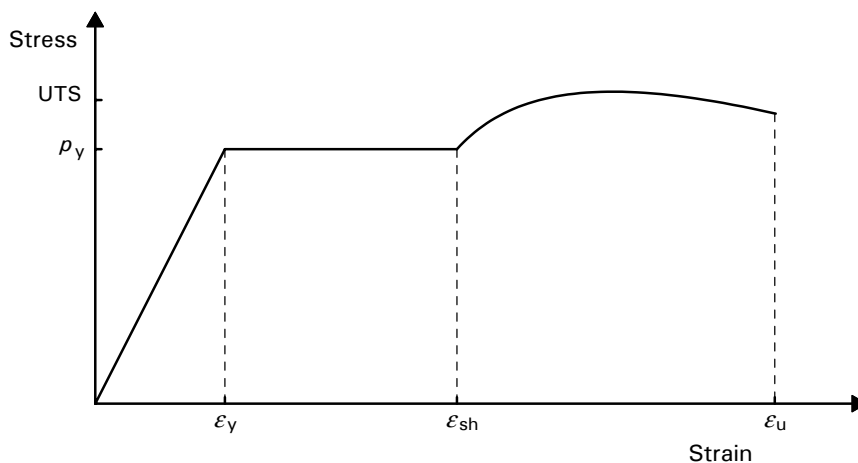


Figure 4.1 *Simplified stress strain curve for steel*

However, when designing members of higher grade steels (i.e. grades not specified in BS 5950-2), it is important to consider the difference between the yield strength and the ultimate tensile strength of the steel and also its ductility and weldability. Rules for steel ductility are given in Clause 5.2.3.3 of the Code.

4.3 Effective area in tension

Where there are no holes in the member and there is no reduction in the cross-sectional area at connections, the effective area A_e is the gross area of the section, A_g .

Where there are holes in a member, the cross-sectional area will be reduced and allowance must be made for this in design.

4.3.1 Allowance for holes

Tests have shown that the presence of holes in a tension member do not generally reduce the capacity of the member, provided that the ratio of the net area to the gross area is greater than the ratio of the yield strength to the ultimate tensile strength. This is because the steel yields and allows redistribution of load around the holes; strain hardening occurs in the highly strained areas adjacent to the holes and stresses in excess of yield can be sustained locally.

The strain hardening behaviour theoretically allows a S275 steel member (with a yield to ultimate ratio of $275/410 = 0.67$) to contain holes equivalent to 33% of its area before the tension capacity of the member is reduced. In design however, caution needs to be exercised to ensure that there is an adequate factor of safety against ultimate failure. This is addressed by the factors in the Code.

In BS 5950-1, allowance is made for the enhancement by strain hardening by increasing the net area (gross area minus deductions for holes). The net area is multiplied by a factor K_e (but may not exceed the gross area, A_g). The values of K_e given in the Code are based on the ratio UTS/yield strength.

The effective net area a_e is given by:

$$a_e = K_e \times a_n \text{ but } \leq a_g$$

where:

$$K_e = 1.2 \text{ for S275 steel}$$

$$K_e = 1.1 \text{ for S355 steel}$$

$$K_e = 1.0 \text{ for S460 steel}$$

$$K_e = U_s / (1.2p_y) \text{ for other grades}$$

a_n is the net area of the element

a_g is the gross area of the element

The tension capacity of a member with holes is given by:

$$P_t = A_e \times p_y$$

Cl. 3.4.2

Cl. 3.4.3

Cl. 4.6.1

where:

A_e is the sum of the effective net areas a_e of all the elements of the section, but not more than 1.2 times the total net area A_n .

Example

Consider the 100×15 mm S275 steel plate shown in Figure 4.2 containing a number of 22 mm diameter holes for 20 mm bolts.

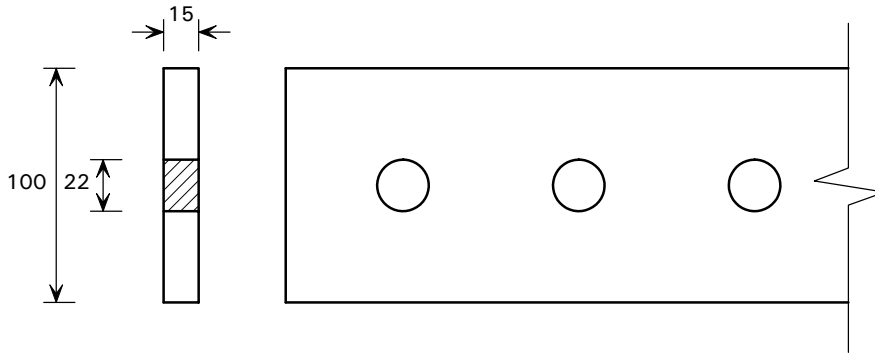


Figure 4.2 Member in tension

$$\text{Gross area } a_g = 100 \times 15 = 1500 \text{ mm}^2$$

$$\text{Net area } a_n = 1500 - (22 \times 15) = 1170 \text{ mm}^2$$

Effective net area $a_e = k_e \times a_n = 1.2 \times 1170 = 1404 \text{ mm}^2$, which is less than a_g

$$A_e = \Sigma a_e$$

$$\text{Tensile capacity} = A_e \times p_y = 1404 \times 275 \times 10^{-3} = 386 \text{ kN}$$

4.3.2 Staggered holes

The code describes how staggered holes across the line of net area should be considered for calculating the effective area.

Cl. 3.4.4.3
Figure 3

4.4 Allowance for eccentricity

4.4.1 General

Where a member is not loaded along its centroidal axis, it is necessary to consider the eccentricity in the design. In general it would be expected that that this eccentricity should be taken account of by the addition of a moment to the tension in the member, see Figure 4.3. The member would then be designed as subject to combined tension and bending, which is covered in Section 9.

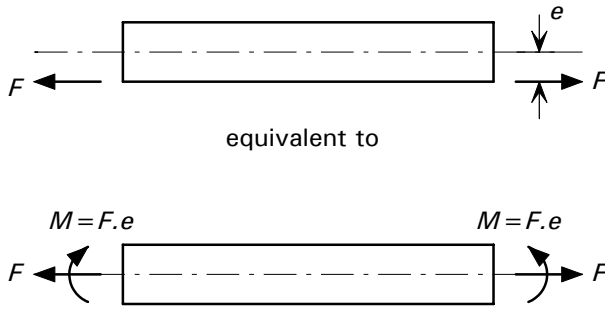


Figure 4.3 *Eccentrically loaded member*

However, this approach can give conservative results in a number of cases. For the common situation of an angle in tension connected by gussets at each end (Figure 4.4) there is an eccentricity due to the bolts about the y-y axis and due to the level of the gusset plate about the x-x axis. If these eccentricities were used to calculate equivalent moments and then the section checked for combined tension and biaxial bending it would be found that yield stress was reached at the extreme fibre of the section at approximately 50% of the tensile capacity of the angle. This would not reflect the actual behaviour of the member and would not be economic for design purposes.

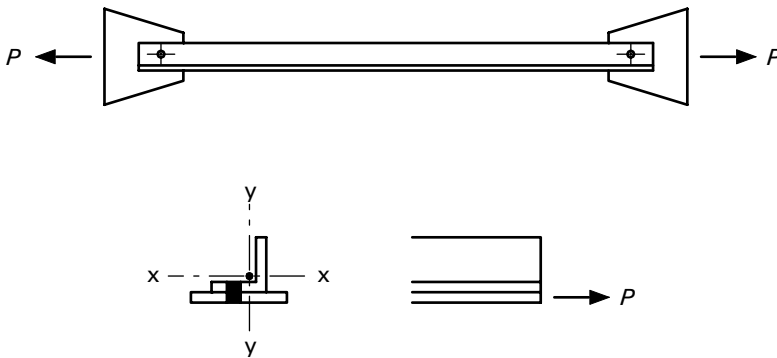


Figure 4.4 *Eccentrically loaded angle*

In reality when tension is applied to the member the angle bends so that its axis is closer to the line of the applied load. The reduction in capacity due to the eccentricity is therefore much less than it would have been had the theoretical eccentric moment been added to the axial load.

To account for the real behaviour, the code presents empirical formulae that allow the member to be designed as axially loaded. The empirical formulae are for common specific cases and use a modified area to account for the eccentricity at the connections.

4.4.2 Single angles, channels and T sections

For single angles connected through one leg only, single channels connected through the web only or T sections connected through the flange only the tension capacity is given by:

For bolted connections $P_t = p_y (A_e - 0.5a_2)$

For welded connections $P_t = p_y (A_g - 0.3a_2)$

Cl. 4.6.3.1

where:

$$a_2 = A_g - a_1$$

a_1 is the gross area of the connected element

A_g is the gross area of the whole section

A_e is the effective area of the whole section, as defined in Section 4.3.

The area of the connected element a_1 is taken as the product of its thickness and the overall leg width for an angle, the overall depth for a channel connected through the web or the flange width for a T section connected through the flange.

4.4.3 Double angles, channels and T sections

For double angles connected through one leg only, double channels connected through the web only and double T sections connected through the flange only the tension capacity is given by:

$$\text{For bolted connections} \quad P_t = p_y (A_e - 0.25a_2)$$

Cl. 4.6.3.2

$$\text{For welded connections} \quad P_t = p_y (A_g - 0.15a_2)$$

The sections must be adequately connected by battens or solid packing pieces in at least two places within their length. If the members are not connected as described they should be designed as two single members.

4.5 Summary of design procedure

1. Select section and grade of steel.
2. Determine the gross area.
3. Calculate the net area. Cl. 3.4.2
4. Calculate the effective area. Cl. 3.4.3
5. Calculate the tension capacity:
6. For axially loaded members, calculate the tension capacity using the effective area. Cl. 4.6.1
7. For simple members with eccentric connections, calculate the tension capacity based on a reduced effective area. Cl. 4.6.3
8. For members subject to combined tension and bending, check the adequacy under combined loading. Cl. 4.6.2
Cl. 4.8.2

5 COMPRESSION MEMBERS

5.1 Introduction

The compression resistance of members is determined by three properties:

- (i) Material strength
- (ii) Section classification
- (iii) Member slenderness

In the Code, the compression resistance is expressed in terms of a compressive strength, which takes account of both material strength and member slenderness, and a cross-sectional area that depends on the cross-section classification. The compression resistance is given by:

For non-slender cross-sections (Class 1, 2 or 3) $P_c = A_g \times p_c$ Cl. 4.7.4

For Class 4 slender cross-sections $P_c = A_{\text{eff}} \times p_{\text{cs}}$

where:

- A_g is the gross area of the section
- A_{eff} is the effective area of the section
- p_c is the compressive strength for a non-slender section
- p_{cs} is the compressive strength for a slender section

5.2 Slenderness

The resistance of a member to overall buckling depends on the slenderness λ . The slenderness is given by:

For non-slender cross-sections (Class 1, 2 or 3) $\lambda = L_E/r$ Cl. 4.7.2

For Class 4 slender cross-sections $\lambda = (L_E/r) \times (A_{\text{eff}}/A_g)^{0.5}$ Cl. 4.7.4

where:

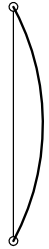
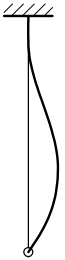



- L_E is the effective length
- r is the radius of gyration, for the relevant axis of buckling
- A_{eff} is the effective area of the section
- A_g is the gross area of the section.

Note: The radius of gyration r is always that of the gross section, even if the section is Class 4 slender and the effective area A_{eff} is used.

5.3 Effective length

The effective length of a compression member is a function of the actual length between restraints and the type of restraint provided. Restraints can be rotational and/or positional. The restraint at the ends of a member will affect the buckled shape of a compression member (see Table 5.1) and therefore the compression resistance. Cl. 4.7.3

Table 5.1 *Buckled shapes and effective lengths L_E*

| Restraint at end 1 | Position only | Position and direction | Position and direction | None | Direction only |
|-----------------------------------|---|---|---|--|---|
| Buckled shape |  |  |  |  |  |
| Restraint at end 2 | Position only | Position only | Position and direction | Position and direction | Position and direction |
| Practical L_E | $1.0L$ | $0.85L$ | $0.7L$ | $2.0L$ | $1.2L$ |

Note: L is the length of the member between restraints

For column design it is necessary to determine the length over which it can buckle, termed the segment length. The length over which a member can buckle is the length between restrained points in that plane. This is the distance between the intersections of the column and the restraining members and will usually be the storey height in a building frame.

In the majority of cases in simple construction, the effective length can be determined from Table 22 of BS 5950-1 (reproduced here in part as Table 5.2). Angles, channels, and T section struts are treated separately, as are members in continuous construction.

Table 22 is separated into non-sway mode and sway mode. Relative movement of the ends of a member are restricted in the non-sway mode. The terms sway mode and non-sway mode used in Table 22 will not necessarily relate directly to sway sensitive and non-sway frames as classified using Clause 2.4.2.6 (see Section 1.6.3). Effective diagonal bracing or shear walls can restrict the relative movement of the ends of a member.

In the extreme case of a member that is fully restrained against rotation and in position at both ends the effective length will be one half of the actual length. This is an idealised case because full rotational restraint is not achievable in practice and therefore the effective length is taken as $0.7L$. It is important to recognise that rotational restraint is provided by the members connected to the beam or column and is also reliant upon the stiffness of the connections to provide this restraint.

If the beams are attached to the columns using flexible connections, it would be unwise to assume any rotational restraint, whatever the stiffness of the beam. Stiff beams connected to the columns using substantial connections such as flush or extended end plates will provide effective rotational restraint. However the above is general advice based upon normal circumstances and the engineer must view each case on its merits.

Table 22

Cl. 4.7.3

Table 5.2 *Effective length of compression members*

| a) Non-sway mode | | | |
|---|--|-----------------------------------|---------|
| Restraint (in the plane being considered) by the other parts of the structure | | | L_E |
| | Effectively restrained in direction at both ends | | $0.7L$ |
| Effectively held in position at both ends | Partially restrained in direction at both ends | | $0.85L$ |
| | Effectively restrained in direction at one end | | $0.85L$ |
| | Not restrained in direction at either end | | $1.0L$ |
| b) Sway mode | | | |
| One end | Other end | | L_E |
| Effectively held in position and restrained in direction | Not held in position | Effectively held in direction | $1.2L$ |
| | | Partially restrained in direction | $1.5L$ |
| | | Not restrained in direction | $2.0L$ |

Table 22

Further guidance on effective lengths of compression members is given in Advisory desk notes AD58^[27], AD59^[28], AD64^[29], AD69^[30] and AD70^[31].

5.4 Compressive strength

The compressive strength is obtained from Table 24 of BS 5950-1 (the 'strut curves') using the design strength p_y and appropriate slenderness λ .

5.4.1 Strut curves

To account for the axis of buckling, initial out-of-straightness and residual stresses a series of four strut curves have been developed for compression members. Table 23 of BS 5950-1 (reproduced here in part as Table 5.3) enables the designer to select the appropriate strut curve for the case under consideration. Figure 5.1 shows the strut curves graphically. In BS 5950-1 the strut curves are presented in tabular format as Tables 24 a), b), c) and d).

Table 5.3 *Allocation of strut curves*

| Type of Section | Thickness mm | Axis of Buckling | |
|-----------------------------------|-----------------|------------------|-----|
| | | x-x | y-y |
| Hot-finished hollow section | n/a | a | a |
| Cold-formed hollow section | n/a | c | c |
| I Section (e.g. Universal beam) | ≤ 40 mm | a | b |
| | > 40 mm | b | c |
| H section (e.g. Universal column) | ≤ 40 mm | b | c |
| | > 40 mm | c | d |
| Welded I or H section | ≤ 40 mm | b | c |
| | > 40 mm | b | d |
| Angles, Channels & T-sections | n/a | c | c |

Table 23

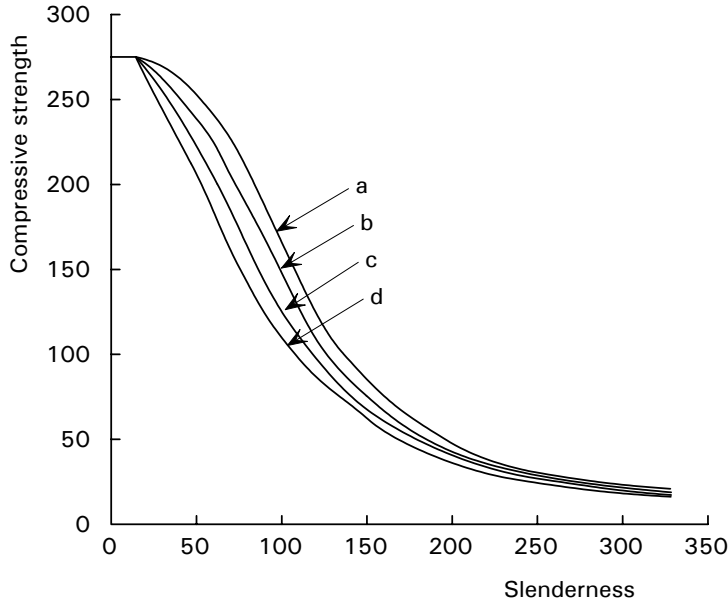


Figure 5.1 *Strut curves (for a design strength of 275 N/mm²)*

5.4.2 Residual stresses

Residual stresses are locked in stresses that are present in any rolled or fabricated section due to the production process, which involves heating and cooling of the section or parts of the section. Such stresses will vary according to the shape of the section and the rate of cooling. The parts that contain locked in compressive stresses will yield prematurely under load, leading to loss of stiffness and reduced buckling strength. The severity of the effect depends on the pattern and the magnitude of the locked in stresses. Figure 5.2 shows the residual stresses for typical sections.

Cold-formed hollow sections have greater residual stresses than hot-finished hollow sections, which is why strut curve c) is used for cold-formed hollow sections and curve a) for hot-finished hollow sections.

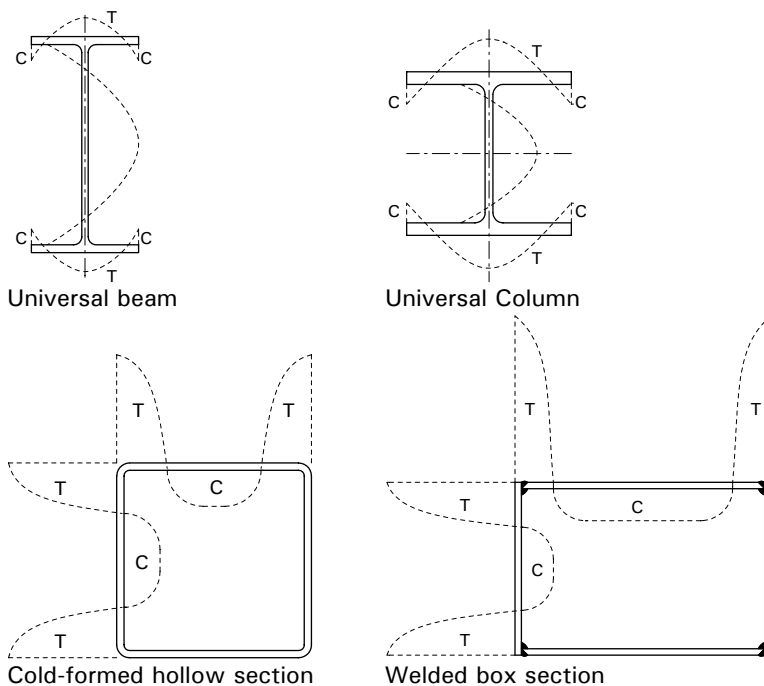


Figure 5.2 *Typical residual stress patterns*

5.4.3 Strut curves for fabricated sections

Fabricated sections should, in theory, need the use of a further set of strut curves but, for simplification, one of the existing four curves is used with a value of design strength taken as $(p_y - 20)$ where p_y is the design strength of the original material.

Cl. 4.7.5

5.5 Section classification

For Class 1 plastic, Class 2 compact or Class 3 semi-compact sections, local buckling does not affect the compression resistance of the cross-section. However, if the section is Class 4 slender, the compression resistance is based on an effective area that includes a reduction to allow for local buckling of the slender elements. The section modulus is also affected by local buckling and a modification is needed to the slenderness, as mentioned in Section 5.2.

Cl. 3.5

It is therefore important to identify whether or not the section is Class 4 slender. If the Class 3 limit is exceeded for any element, the cross-section should be classified as Class 4 slender and an effective area used in the design. Table 5.4 summaries the section classification limits for common cross-sections.

For the sections shown in Table 5.4 the classification limits vary with the level of applied axial compressive load. Therefore, the section classification may change if the axial compressive load changes.

Table 5.4 Class 3 classification limits for compression members

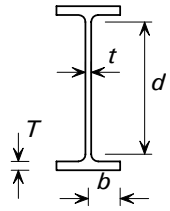
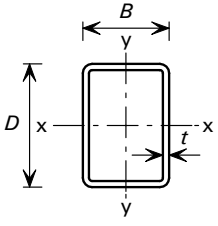
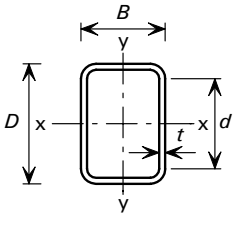
| Section | Flange | Web |
|---|-----------------------------|--|
|  | Open section | |
| | $b/T \leq 15\epsilon$ | $d/t \leq \frac{120\epsilon}{1+2r_2}$ and 40ϵ |
|  | Hot-finished hollow section | |
| | $b/t \leq 40\epsilon$ | $d/t \leq \frac{120\epsilon}{1+2r_2}$ and 40ϵ |
|  | Cold-formed hollow section | |
| | $b/t \leq 35\epsilon$ | $d/t \leq \frac{105\epsilon}{1+2r_2}$ and 35ϵ |

Table 11
Table 12

Note: For all cases shown $r_2 = F_c / (A_g p_y)$. Classification limits for other cross-sections are given in Tables 11 and 12 of BS 5950-1

5.6 Members in lattice frames and trusses

Members in lattice frames and trusses using angles, channels and T sections are treated in the same way as other compression members, apart from the method of determining the slenderness.

The code presents a method for determining the slenderness λ of angles, channels and T sections that allows for:

- The effective length, influenced by the type of connection.
- The eccentricity at the connection caused by the type of section and the position of the gusset plate.
- The possibility of short members buckling about the stronger axis due to a flexible gusset plate at the end.

The method has been justified on the basis of test work carried out on large lattice frames and towers.

For laced and battened struts, there are additional rules, which when followed, allow them to be designed as single integral members.

Cl. 4.7.10
Table 25

Cl. 4.7.8
Cl. 4.7.9

5.7 Members in continuous construction

The design of members in continuous construction is dealt with in Section 5 of the code. The procedures depend on considering the frame as a whole and the stiffness of individual members framing into the column. The subject is covered in Section 14 of this publication, but it is important to recognise that the simple approach to effective lengths, as given in Table 22 of BS 5950-1, is not applicable to members in continuous frames. Annex E of the code gives figures to determine the effective length of members in continuous construction.

5.8 Summary of design procedure

1. Select section and steel grade
2. Determine design strength p_y
3. Determine gross cross-sectional area and radius of gyration.
4. For Class 4 slender sections, calculate the effective area.
5. Determine the effective length L_E :
 - For simple members
 - For members in continuous construction
6. Calculate member slenderness λ :
 - For non-slender sections (Class 1, 2 and 3) $\lambda = L_E/r$
 - For Class 4 slender sections $\lambda = (L_E/r) \times (A_{eff}/A_g)^{0.5}$
 - For angles, channels and T sections

Table 9

Table 11

Table 12

Cl. 3.6

Table 22

Annex E

Cl.4.7.4

Cl. 4.7.5

Table 25

Cl. 4.7.10

- | | BS 5950-1 |
|---|-----------|
| 7. Select appropriate strut curve according to section shape and axis of buckling | Table 23 |
| 8. Obtain the compressive strength from the appropriate strut table using the design strength (or $p_y - 20$ for Class 4 sections) and slenderness. | Table 24 |
| 9. Calculate the compression resistance. | Cl. 4.7.4 |

6 RESTRAINED BEAMS

6.1 Introduction

The top flange of a simply supported beam subject to gravity loads will be in compression and like any element in compression will try to buckle. The bottom flange is in tension and will try to remain straight. Therefore, if there is insufficient restraint to the top flange, it will buckle laterally, i.e. out of the plane of the applied load. The lateral buckling of the compression flange of a beam involves lateral torsional buckling, which is considered more fully in Section 7. A restrained beam is one in which the compression flange is prevented from buckling laterally.

To ensure satisfactory performance a restrained beam must be checked for:

- (i) Adequate lateral restraint
- (ii) Section classification
- (iii) Shear
- (iv) Combined bending and shear
- (v) Web bearing and buckling
- (vi) Deflection

Each of these factors will be considered separately in this Section.

6.2 Lateral restraint

To prevent lateral torsional buckling and allow the section to achieve its full moment capacity it is important that the compression flange is fully restrained laterally so that only vertical movement of the beam is allowed.

Full lateral restraint is defined in the code as:

“Full lateral restraint may be assumed to exist if the frictional or positive connection of a floor (or other) construction to the compression flange of the member is capable of resisting a lateral force of not less than 2.5% of the maximum force in the compression flange of the member (*under factored loading*). This lateral force should be considered as distributed uniformly along the flange...”

Cl. 4.2.2

In practice, most floor constructions would be considered adequate to carry this force, but care should be taken with timber floors, where positive fixing should be provided.

To check the adequacy of the restraint provided by the floor, the following approximations can be used.

Force in compression flange = Maximum moment / Depth of section

Frictional force = Load × Coefficient of friction / Length of beam

6.3 Section Classification

As explained in Section 3, the elements of the cross-section can be classified by reference to Tables 11 and 12 of BS 5950-1 as Class 1 plastic, Class 2 compact, Class 3 semi-compact or Class 4 slender. The bending capacity of the beam depends on the classification of the whole cross-section.

The moment/rotation characteristics of the four section classes are shown graphically in Figure 3.3 and Table 6.1 summarises the moment capacities, for each of the classes.

Table 6.1 Section classification and moment capacities

| Classification | Stress block diagram | Moment capacity |
|----------------------|----------------------|---|
| Class 1 plastic | | $M_c = p_y S$ |
| Class 2 compact | | $M_c = p_y S$ |
| Class 3 semi-compact | | $M_c = p_y S_{eff}$ or $M_c = p_y Z$ (conservatively) |
| Class 4 slender | | $M_c = p_y Z_{eff}$ or $M_c = p_{yr} Z$ (conservatively) |

Note: All terms are defined in Section 6.5.1

Universal Beam and Universal Column sections subject to pure bending are all Class 3 semi-compact or better. Thin walled rectangular hollow sections subject to bending may be Class 4 slender, particularly when subject to bending about the y-y axis.

By carrying out section classification and using the design procedure appropriate to that classification, due allowance will have been made for local buckling.

6.4 Shear

The resistance of a beam to shear is determined by either the shear capacity or, for thin webs, the shear buckling resistance. These webs are defined in the code as those for which $d/t > 70\epsilon$ for rolled sections and $d/t > 62\epsilon$ for welded sections. Such webs only occur in fabricated sections; shear buckling resistance is therefore covered in Section 13, Plate Girders.

The shear capacity of a section is defined as:

$$P_v = 0.6 p_y A_v$$

Cl. 4.2.3

where:

p_y is the design strength of the section

A_v is the shear area of the section.

Generally, the shear area can be described as the area of the rectilinear elements of the cross-section that have their largest dimension in the direction parallel to the shear force. For rolled I and H sections, loaded in their major axis, A_v is the overall depth of the section multiplied by its web thickness.

6.5 Combined bending and shear

The code deals with the interaction of bending and shear under two classes of the level of the shear, high and low shear.

6.5.1 Moment capacity with low shear

If the shear force F_v does not exceed 60% of the shear capacity P_v , the effect of shear on the bending capacity is low enough to be ignored.

For these cases, the moment capacity is given by:

For Class 1 plastic $M_c = p_y S$

For Class 2 compact sections $M_c = p_y S$

For Class 3 semi-compact sections $M_c = p_y S_{x,eff}$ or

$M_c = p_y Z$ (conservatively)

For Class 4 slender sections $M_c = p_y Z_{eff}$

where:

S is the section plastic modulus

$S_{x,eff}$ is the section effective plastic modulus

Z is the section elastic modulus

$Z_{x,eff}$ is the section effective elastic modulus

p_y is the section design strength

p_{yr} is the section reduced design strength.

For Class 4 sections, as explained in Section 3.4.2, Clause 3.6.5 offers the alternative of using the use of a reduced design strength p_{yr} and then treating the cross-section as Class 3. This method will give conservative results compared to the method of using an effective elastic modulus. The code Clauses generally assume that the designer will be using effective section properties rather than reduced design strengths.

In order to prevent permanent deformations at working load the moment capacity of simply supported beams and cantilevers should be limited to $1.2 p_y Z$. For other cases the limit is $1.5 p_y Z$ generally.

Cl. 4.2.5.2

Cl. 4.2.5.1

6.5.2 Moment capacity with high shear load

If the shear load is greater than 60% of the shear capacity, the effect of shear should be taken into account when calculating the moment capacity.

For these cases, the moment capacity is given by:

For Class 1 plastic or Class 2 compact sections $M_c = p_y (S - \rho S_v)$

For Class 3 semi-compact sections $M_c = p_y (S_{x,eff} - \rho S_v)$ or

$$M_c = p_y (Z - \rho S_v / 1.5)$$

For Class 4 slender sections

$$M_c = p_y (Z_{eff} - \rho S_v / 1.5)$$

where:

$$\rho = (2 (F_v / P_v) - 1)^2$$

S_v is the plastic modulus of the shear area for sections with equal flanges (i.e. $Dt^2/4$)

S_v is the plastic modulus of the whole section minus the plastic modulus of the flanges for sections with unequal flanges

All other terms are as defined in Section 6.5.1.

The parameter ρ takes account of the level of shear in the section and tends to zero at $F_v = 0.5P_v$ although the reduction is trivial until $F_v > 0.6P_v$.

Alternatively, for Class 3 semi-compact sections, reference may be made to Annex H.3 of BS 5950-1, or for Class 4 slender sections reference may be made to Clause 3.6 and Annex H.3 of BS 5950-1.

6.5.3 Elastic and plastic analysis

It should be noted that the use of a plastic modulus does not necessarily mean that plastic analysis will be used in the design of the frame. It is usual to carry out an elastic analysis and then provide sufficient moment capacity, calculated as above, at the position of maximum moment.

To illustrate the different design requirements for elastic and plastic analysis, consider a built in beam of span L supporting a uniformly distributed load of w kN/m length, as shown in Figure 6.1. The section is Class 1 plastic.

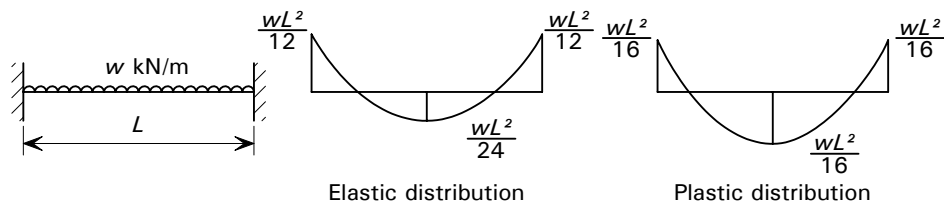


Figure 6.1 Methods of beam analysis

For an elastic analysis, the end moments will be greatest and equal to $wL^2/12$, see Figure 6.1. Therefore, the design capacity required will be $wL^2/12$. For Class 1 and Class 2 sections with 'low' shear, the beam's moment capacity = $p_y S$. Hence, for a given beam size, the maximum load that can be sustained $w = 12 p_y S / L^2$.

Cl. 4.2.5.3

For a plastic analysis the load on the same beam may be increased until three plastic hinges have formed (one at each end and one at the centre), see Figure 6.1. The moment at each of these hinges will be $w'L^2/16$. In this case the maximum load that can be sustained is $w' = 16 p_y S/L^2$.

Therefore, $w'/w = 1.3$. This shows a 30% increase in the apparent load carrying capacity of the beam by using plastic analysis.

Note that in this example the beam is under negative or hogging moments at the supports. In these regions the bottom flange is in compression and that part of the beam will have to be checked as an unrestrained beam (see Section 7).

6.6 Web bearing and buckling

Where loads are applied directly through the flange of the section, for example where a load is applied to the top flange from an incoming beam, the web should be checked for bearing and buckling. Web bearing and buckling design is covered in Section 8 of this publication.

6.7 Deflection

It should be noted that this Section (i.e. 6.7) applies to both restrained and unrestrained beams.

Deflection is a serviceability limit state and in general calculations should be based on unfactored imposed load. However, there are some exceptions. Calculated deflections should be checked against the suggested limits given in Table 8 of BS 5950-1 (reproduced here in part as Table 6.2).

Cl. 2.5.1

Table 6.2 *Suggested deflection limits (from BS 5950-1)*

| | |
|---|-------------------|
| a) Vertical deflection of beams due to unfactored imposed load | |
| Cantilevers | Length/180 |
| Beams carrying plaster or other brittle finishes | Span/360 |
| Other beams (except purlins and sheeting rails) | Span/200 |
| b) Horizontal deflection of columns due to unfactored imposed load and wind load | |
| Tops of columns in single storey buildings (except portal frames) | Height/300 |
| In each storey of a building with more than one storey | Storey height/300 |
| c) Crane Girders | |
| Vertical | Span/600 |
| Horizontal | Span/500 |

Table 8

The limitations given in Table 6.2 are based on commonly accepted principles, but the code recognises that “circumstances may arise where greater or lesser values may be more appropriate”. The code also makes it clear that the limitations are given to ensure that finishes are not damaged. For example the traditionally accepted value of span/360 for beams is based on prevention of damage to plaster ceilings below the beam. In other cases a more relaxed limit of span/200 is allowed.

Cl. 2.5.2

Vertical and horizontal deflection limits are given for crane gantry girders, which appear rather restrictive (span/600 and span/500 respectively). It is recommended that the manufacturer is consulted to ascertain the actual deflections that the crane can tolerate during operation. It should be noted that in this case the total load of the crane as well as the lifted load should be treated as 'imposed' load.

In some cases it may be necessary to calculate deflections due to dead load, to ensure that the structure has an acceptable appearance or that any clearance or tolerance requirements are met. This may be a wise precaution when using long slender composite beams, as high deflections can result due to the weight of the concrete on the non-composite beam. This is of particular significance if there are no ceilings beneath the beams. In some cases, such as portal frame rafters and lattice girders, the dead load deflection can be 'removed' by carefully presetting members. In the case of long members, dead load deflection can be dealt with by the use of pre-cambering, but cambers less than span/100 are unlikely to be successful.

Deflections at the serviceability limit state can be calculated for simply supported beams, from the following standard formulae.

$$\text{For a UDL with total load of } W \text{ kN} \quad \delta = \frac{5}{384} \frac{WL^3}{EI}$$

$$\text{For a central point load of } W \text{ kN} \quad \delta = \frac{1}{48} \frac{WL^3}{EI}$$

$$\text{For point loads of } W \text{ kN at } 1/3 \text{ points} \quad \delta = \frac{23}{648} \frac{WL^3}{EI}$$

where:

- δ is the beam mid-span deflection
- L is the length of the member
- E is the Young's modulus
- I is the second moment of area about the axis of loading

6.8 Summary of design procedure

- | | |
|---|----------------------|
| 1. Select section and steel grade | |
| 2. Determine the design strength p_y | Table 9 |
| 3. Check the compression flange is laterally restrained | Cl. 4.2.2 |
| 4. Determine the section classification | Table 11 Table 12 |
| 5. For Class 1 and Class 2 sections use the gross section properties | |
| 6. For Class 3 semi-compact sections calculate the effective plastic modulus | Cl. 3.6 |
| 7. For Class 4 slender sections calculate the effective elastic modulus | Cl. 3.6 |
| 8. Calculate the shear capacity and determine whether the section is subject to low shear or high shear | Cl. 4.2.3 |

- | | BS 5950-1 |
|---|-----------|
| 9. Calculate the moment capacity for low shear or for high shear as appropriate and verify adequacy | Cl. 4.2.5 |
| 10. If appropriate check web bearing and buckling | Cl. 4.5 |
| 11. Calculate the deflections and check against appropriate limit. | Cl. 2.5.2 |

7 UNRESTRAINED BEAMS

7.1 Introduction

An unrestrained beam (i.e. without full lateral restraint, as described in Section 6.2) is susceptible to lateral torsional buckling. Lateral torsional buckling (LTB) is the combined lateral (sideways) deflection and twisting of an unrestrained member subject to bending about its major axis, as shown in Figure 7.1. LTB can either occur over the full length of a member or between points of intermediate lateral restraint.

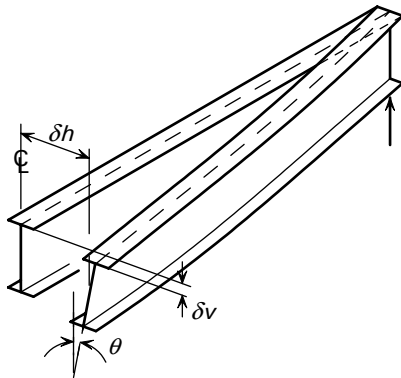


Figure 7.1 *Lateral torsional buckling*

Lateral torsional buckling occurs in unrestrained beams because the compression flange will try to buckle laterally about the beam's more flexible minor axis. The section then twists because the other flange is in tension and is reluctant to buckle. Figure 7.1 shows the lateral deflection δh , the vertical deflection δv and the twisting θ .

When a steel beam is designed, it is usual to first consider the need to provide adequate strength and stiffness against vertical bending. This leads to a member in which the stiffness in the vertical plane is much greater than that in the horizontal plane. Sections normally used as beams have the majority of their material concentrated in the flanges that are made relatively narrow so as to prevent local buckling. Open sections (i.e. I or H sections) are usually used because of the need to connect beams to other members. The combination of all these factors results in a section whose torsional and lateral stiffnesses are relatively low, which has a major affect on the buckling resistance of an unrestrained member.

Many types of construction effectively prevent lateral torsional buckling, thereby enabling the member to be designed by considering its performance in the vertical plane only. Conventional composite beam and slab construction is an example of where the member is restrained to prevent lateral buckling, but it should be recognised that during the construction phase the member may be unrestrained. Hence, although the construction load may be less than the final design load, checks on the adequacy of the member should be carried out for the construction phase loading, treating the beam as unrestrained.

Lateral torsional buckling is only possible where the beam has a less stiff minor axis (i.e. $I_x > I_y$). Hence, circular and square hollow sections need not be designed for lateral torsional buckling. Rectangular hollow sections only need to be designed for lateral torsional buckling if they are relatively tall and narrow (see Table 15 of BS 5950-1).

Situations where lateral torsional buckling has to be taken into account include gantry girders, runway beams and members supporting walls and cladding.

7.2 Factors influencing buckling resistance

The following factors all influence the buckling resistance of an unrestrained beam:

- The length of the unrestrained span, i.e. the distance between points at which lateral deflection is prevented.
- The lateral bending stiffness of the section.
- The torsional stiffness of the section.
- The conditions of the restraint provided by the end connections.
- The position of application of the applied load and whether or not it is free to move with the member as it buckles.

All the factors above are brought together in a single parameter λ_{LT} , the 'equivalent slenderness' of the beam.

The shape of the bending moment diagram also has an effect on the buckling resistance. Members that are subject to non-uniform moments will have a varying force in the compression flange and will therefore be less likely to buckle than members that have a uniform force in the compression flange. This is taken into account by the parameter m_{LT} (see Section 7.4.3 and 7.6).

7.3 Behaviour of beams

The buckling resistance moment of an unrestrained beam depends on its equivalent slenderness λ_{LT} and this relationship can be expressed as a 'buckling curve', as shown by the solid line in Figure 7.2.

- Short stocky members will attain the full plastic moment M_p .
- Long slender members will fail at moments approximately equal to the elastic critical moment M_{cr} . This is a theoretical value that takes no account of imperfections and residual stress.
- Beams of intermediate slenderness fail through a combination of elastic and plastic buckling. Imperfections and residual stresses are most significant in this region.

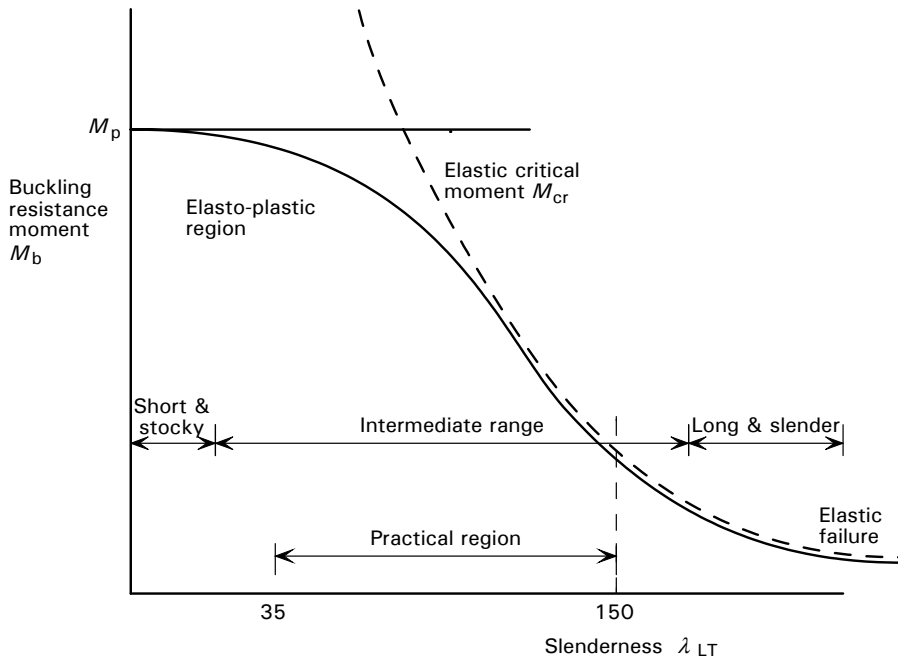


Figure 7.2 Behaviour of beams with regard to slenderness

7.4 Design requirements

7.4.1 General

The Code states that an unrestrained beam must be checked for local moment capacity of the section and also for buckling resistance. However, lateral torsional buckling need not be checked for the following situations:

- Circular or square hollow sections or solid bars.
- Section bending only about the minor axis.
- I, H or channel sections when the equivalent slenderness λ_{LT} is less than a limiting slenderness value λ_{L0}
- Rectangular hollow sections when L_E/r_y is less than a limiting value, as given in Table 15 of BS 5950-1:2000.

Cl. 4.3.1

Cl. 4.3.6.1

Table 15

7.4.2 Moment capacity

The section classification and moment capacity of the section should be determined and checked in the same way as for restrained beams i.e.

Cl. 4.2.5

$$M_x \leq M_{cx}$$

Cl. 4.3.6.2

where:

M_x is the maximum major axis moment in the segment under consideration

M_{cx} is the major axis moment capacity of the cross-section (see Section 6.5)

Any reductions for high shear forces should be included in this check.

Cl. 4.2.5.3

7.4.3 Buckling resistance

The buckling resistance of the member between either the ends of the member or any intermediate restraints, a 'segment', should be checked as:

$$M_x \leq M_b/m_{LT}$$

where:

M_x is the maximum major axis moment in the segment under consideration

M_b is the buckling resistance moment

m_{LT} is the equivalent uniform moment factor for LTB (see Section 7.6).

Buckling resistance moment

The buckling resistance moment M_b is dependent on the section classification of the member and a bending strength p_b that depends on the slenderness of the beam. M_b is calculated as follows:

For Class 1 plastic $M_b = p_b S_x$

For Class 2 compact sections $M_b = p_b S_x$

For Class 3 semi-compact sections $M_b = p_b S_{x,eff}$ or

$M_b = p_b Z_x$ (conservatively)

For Class 4 slender sections $M_b = p_b Z_{x,eff}$

where:

p_b is the bending strength

S_x is the section plastic modulus

$S_{x,eff}$ is the section effective plastic modulus

Z_x is the section elastic modulus

$Z_{x,eff}$ is the section effective elastic modulus

Bending strength

The value of the bending strength p_b is obtained from Tables 16 and 17 of BS 5950-1 and depends on the value of the equivalent slenderness λ_{LT} and the design strength p_y .

For I and H sections, the equivalent slenderness is given by:

$$\lambda_{LT} = u v \lambda (\beta_w)^{0.5}$$

where:

u is a buckling parameter obtained from section property tables

v is a slenderness factor obtained from Table 19 of BS 5950-1 and depends on λ/x

x is the torsional index, obtained from section property tables

λ is the slenderness, taken as L_E/r_y

L_E is the effective length between points of restraint (see Section 7.5)

r_y is the radius of gyration about the minor axis

Cl. 4.3.6.2

Cl. 4.3.6.4

Cl. 4.3.6.5

$\beta_w = 1.0$ for Class 1 and Class 2 sections

$\beta_w = S_{x,eff}/S_x$ for Class 3 sections when $S_{x,eff}$ is used to calculate M_b

$\beta_w = Z_x/S_x$ for Class 3 sections when Z_x is used to calculate M_b

$\beta_w = Z_{x,eff}/S_x$ for Class 4 sections.

For a quick and conservative design of rolled I or H sections with equal flanges, u may be taken as 0.9, v may be taken as 1.0 and x may be taken as D/T , where D is the depth of the section and T is the thickness of the flange. Cl. 4.3.6.8

The above expression for λ_{LT} can also be used for channel sections, provided that certain conditions given in the code are met. Cl. 4.3.6.7b

For a rectangular hollow section for which L_E/r_y exceeds the limiting value given in Table 15 of BS 5950-1, the equivalent slenderness λ_{LT} should be calculated using Annex B.2.6 of BS 5950-1. Cl. 4.3.6.7c

7.5 Effective length

7.5.1 Beams without intermediate lateral restraints

The simple model of lateral torsional buckling on which the Codes rules are based, assumes that the ends of the member are effectively pinned in both the vertical and horizontal planes. The type of restraint provided in practice at the ends of the member needs to be considered and this is done by use of an effective length; the effective length may be greater than or less than the actual length of the member between restraints. Cl. 4.3.5

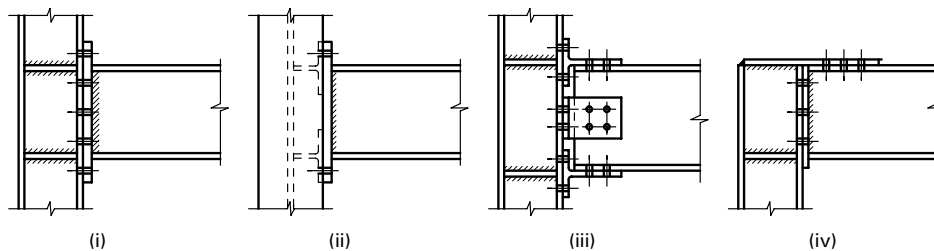
Values of effective length L_E are given in BS 5950-1 Table 13 for beams and Table 14 for cantilevers. Part of Table 13 is reproduced here as Table 7.1. Cl. 4.3.5.1
Cl. 4.3.5.4

For most beams, the effective length will be less than or equal to the actual length. However, if the member is torsionally unrestrained at the end, or the load is destabilising then the effective length may be greater than the actual length. This is reflected in the values given in Tables 13 and 14 of the code.

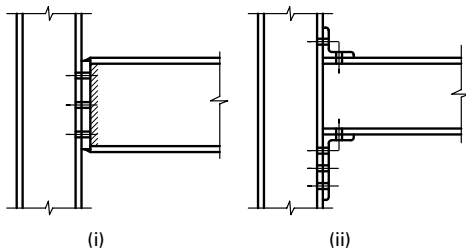
Table 7.1 *Effective length for beams without intermediate restraint*

| Conditions of restraint at supports | Common detail (see Figure 7.3) | Loading Condition | |
|--|--|-------------------|-------------------|
| | | Normal | Destabilising |
| Compression flange laterally restrained and nominal restraint against rotation about longitudinal axis | (a) Both flanges fully restrained against rotation on plan | $0.70 L_{LT}$ | $0.85 L_{LT}$ |
| | (b) Both flanges partially restrained against rotation on plan | $0.80 L_{LT}$ | $0.95 L_{LT}$ |
| | (c) Both flanges free to rotate on plan | $1.00 L_{LT}$ | $1.20 L_{LT}$ |
| Compression flange laterally unrestrained and both flanges free to rotate on plan | (d) Partial torsional restraint against rotation about longitudinal axis provided by connection of bottom flange to supports | $1.0 L_{LT} + 2D$ | $1.2 L_{LT} + 2D$ |
| | (e) Partial torsional restraint against rotation about longitudinal axis provided by pressure of bottom flange onto supports | $1.2 L_{LT} + 2D$ | $1.4 L_{LT} + 2D$ |

Note: L_{LT} is the segment length equal to the span



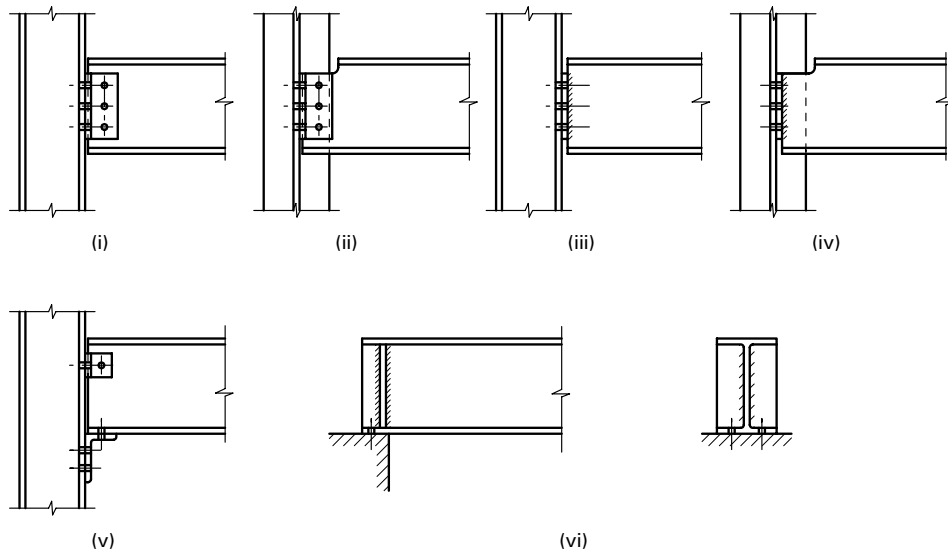
a) Both flanges fully restrained against rotation on plan



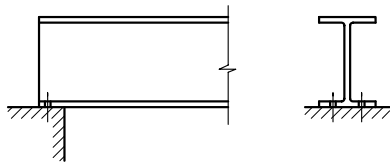
b) Both flanges partially restrained against rotation on plan

Figure 7.3 *Connection details*

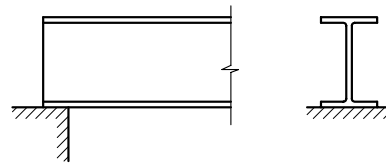




c) Both flanges free to rotate on plan



d) Partial torsional restraint against rotation about longitudinal axis provided by connection of bottom flange to supports



e) Partial torsional restraint against rotation about longitudinal axis provided by pressure of bottom flange onto supports

Figure 7.3 Connection details

7.5.2 Destabilising loads

Destabilising loads are loads that are applied to the beam above the shear centre and are free to move with the beam as it deflects laterally and twists (see Figure 7.4). Such loads increase the twist on the beam and induce additional stresses. Therefore, destabilising loads reduce the resistance of a member to lateral torsional buckling and to account for this the effective length is increased as shown in Table 7.1. Also the equivalent uniform moment factor m_{LT} should be taken as 1.0. Theoretically, the effective length could be decreased if the load was applied below the shear centre but the code makes no allowance for this.

Cl. 4.3.4

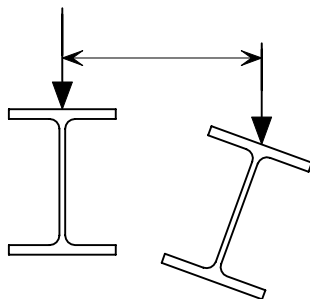


Figure 7.4 Destabilising loads

7.5.3 Beams with intermediate lateral restraints

A segment, i.e. a length of beam between intermediate lateral restraints, can be designed as a member without intermediate restraints. The effective length of the segment should be taken as $1.0 L_{LT}$ for normal loading conditions and $1.2 L_{LT}$ for destabilising loads, where L_{LT} is the length of the relevant segment between restraints.

Cl. 4.3.5.2

Any intermediate restraints must have adequate stiffness and strength. The code defines adequate strength as the restraint being able to resist a force of 2.5% of the maximum factored force in the compression flange divided between the points of restraint in proportion to their spacing. Where three or more intermediate lateral restraints are provided, the force in each restraint should not be taken as less than 1% of the total force within the relevant span.

Cl. 4.3.2.2

Where several members share a common restraint, the restraint design force should be taken as the sum of the lateral restraint forces from each member reduced by the factor k_r . Where $k_r = (0.2 + 1/N_r)^{0.5}$ and N_r is the number of parallel members restrained by the same restraint. In the example shown in Figure 7.5, the diagonal bracing system should be designed for three transverse point loads, each equal to $(0.01\Sigma N) \times \sqrt{0.533}$, (where ΣN is the sum of the three compression flange forces).

If parallel members are taken as sharing the same restraint system the system should be anchored to a robust part of the structure as shown in Figure 7.5, or a system of triangulated bracing should be provided in, or close to, the compression flange.

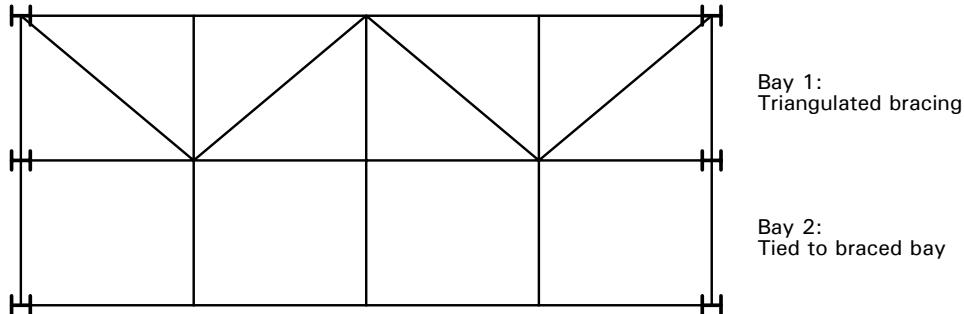


Figure 7.5 *Bracing of parallel members*

Adequate stiffness is difficult to define but it has been suggested that this can be achieved by making the stiffness of the braced system 25 times stiffer in the lateral direction than the member being restrained. This is a good rule of thumb and is easily achieved with triangulated systems. It can however cause problems if the element to be braced is already very stiff in the lateral direction and therefore should be applied with care.

7.6 Equivalent uniform moment factor

The values of the bending strength given in Tables 16 and 17 of BS 5950-1 are for a beam subject to uniform moment, as shown in Figure 7.6. In members that are subject to non-uniform moments the compressive force in the flange varies along the beam and the beam is likely to be able to sustain a higher peak value of bending moment than if the moment were uniform.

Cl. 4.3.6.6

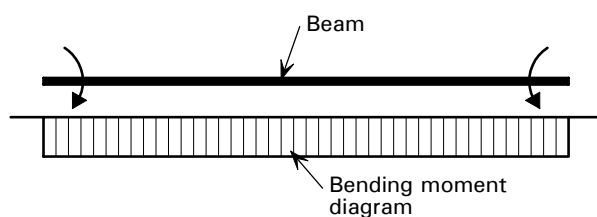


Figure 7.6 *Member subject to uniform moment*

The equivalent uniform moment factor m_{LT} takes account of the shape of the bending moment diagram between restraints and is obtained from Table 18 BS 5950-1 (reproduced here as Table 7.2). The first part of the table deals with linear moment gradients, i.e. members with no load between restraints. The second part deals with specific cases of members that are subject to transverse loading and the third part provides a general formulae from which m_{LT} may be calculated for more complex cases such as continuous beams. The general formulae may be used to derive the values of m_{LT} in the first two parts of the table.

Table 7.2 *Equivalent uniform moment factor m_{LT} for lateral torsional buckling*

Table 18

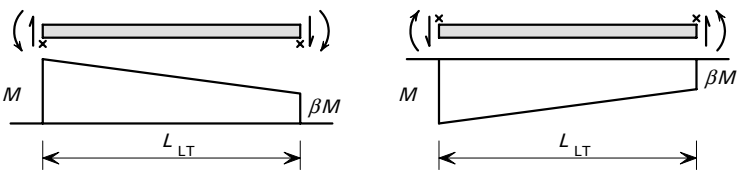
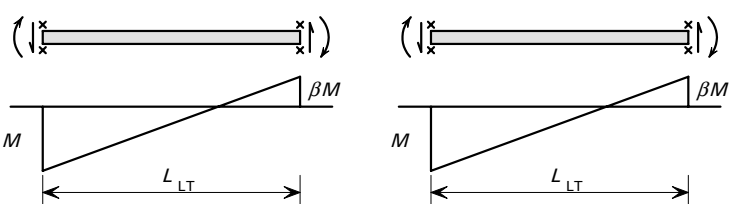
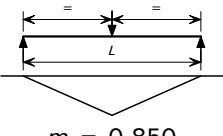
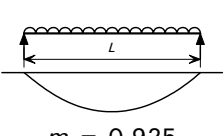
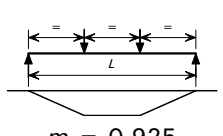
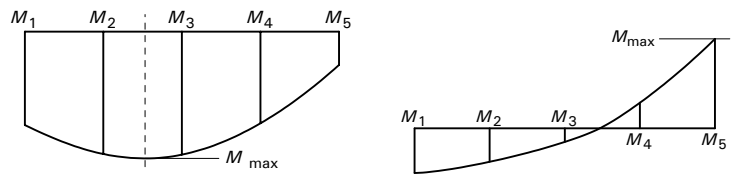
| Segments with end moments only (m_{LT} from formula for general case) | β | m_{LT} |
|---|--|---|
| β positive  | 1.0 | 1.00 |
| | 0.9 | 0.96 |
| | 0.8 | 0.92 |
| | 0.7 | 0.88 |
| | 0.6 | 0.84 |
| | 0.5 | 0.80 |
| | 0.4 | 0.76 |
| | 0.3 | 0.72 |
| | 0.2 | 0.68 |
| | 0.1 | 0.64 |
| | β negative  | 0.0 |
| -0.1 | | 0.56 |
| -0.2 | | 0.52 |
| -0.3 | | 0.48 |
| -0.4 | | 0.46 |
| -0.5 | | 0.44 |
| -0.6 | | 0.44 |
| -0.7 | | 0.44 |
| -0.8 | | 0.44 |
| -0.9 | | 0.44 |
| -1.0 | 0.44 | |
| Specific cases (no intermediate lateral restraints) | | |
|  |  |  |
| $m = 0.850$ | $m = 0.925$ | $m = 0.925$ |
| Note: The point loads and the UDL provide no lateral restraint to the beam | | |
| General case (segments between intermediate lateral restraints) | | |
|  | | |
| For beams: $m_{LT} = 0.2 + \frac{0.15M_2 + 0.5M_3 + 0.15M_4}{M_{max}}$ but $m_{LT} \geq 0.44$ | | |
| All moments are taken as positive. The moments M_2 and M_4 are the values at the quarter points, the moments M_3 is the value at mid length and M_{max} is the maximum moment in the segment. | | |
| For cantilevers without intermediate lateral restraint: $m_{LT} = 1.00$ | | |

Figure 7.7 shows four simply supported beams with different loading conditions. The equivalent uniform moment factor can be determined for each beam as follows:

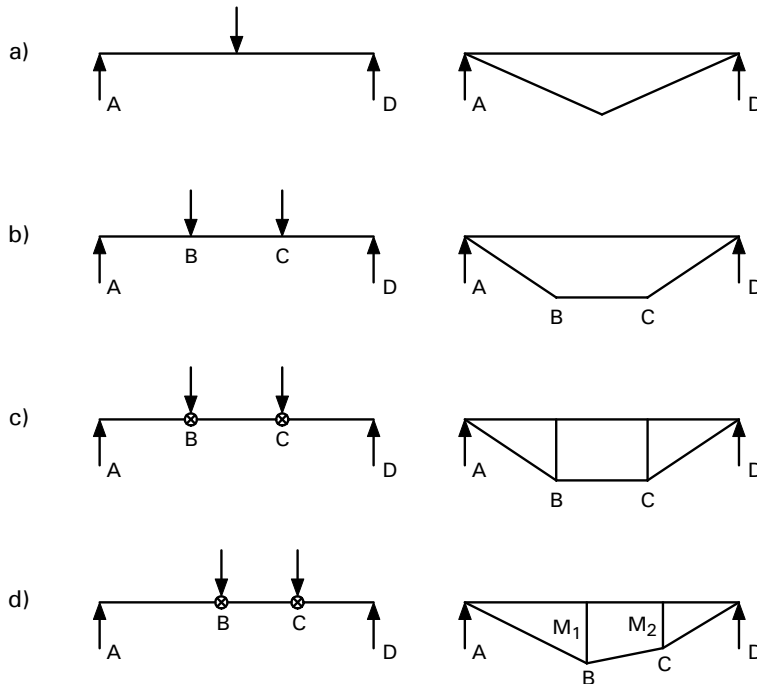


Figure 7.7 Examples of the effect of moment gradient on m_{LT}

- **Beam (a)** has a central point load that does not restrain the beam. The unrestrained length is therefore equal to the length of the beam A-D. The compression flange is subject to a varying compression and the equivalent uniform moment factor is 0.85, which is obtained from the specific cases part of Table 7.2.
- **Beam (b)** is subject to two point loads that do not restrain the beam. The unrestrained length is therefore equal to the length of the beam A-D. The central portion of the beam is in uniform compression and the beam is more likely to buckle than Beam (a). In this case the equivalent uniform moment factor is 0.925, which is obtained from the specific cases part of Table 7.2.
- **Beam (c)** is subject to two point loads that do restrain the beam. In this case the unrestrained lengths are between the end and the intermediate restraint A-B, between the intermediate restraints B-C and between the restraint and the end C-D. The central portion of the beam is in uniform compression and, providing the three lengths between restraints are equal, it is length B-C that will be critical because the equivalent uniform moment factor is 1.0.
- **Beam (d)** is subject to two point loads that do restrain the beam. The loading arrangement of this beam does not fit into any of the specific cases given in Table 7.2. However, because there is no loading applied between the points of restraint, the equivalent uniform moment factor can be determined from β , the ratio of the smaller end moment to the larger end moment for a particular segment.

For segment A-B, β equals zero, which gives an equivalent uniform moment factor from Table 7.2 equal to 0.6. The unrestrained length would be taken the length A-B.

For segment B-C, β equals M_2/M_1 , which will give an equivalent uniform moment factor from Table 7.2 less than 1.0. The unrestrained length would be taken as the length B-C.

For segment C-D, β equals zero, which gives an equivalent uniform moment factor from Table 7.2 equal to 0.6. The unrestrained length would be taken as the length C-D.

In every case, the buckling resistance moment is compared to the maximum moment within the segment. For beam (d) the maximum moment would be M_1 for A-B and B-C and M_2 for C-D. Note that in this particular case segment C-D would not be critical.

For destabilising loads (see Section 7.5.2), equivalent uniform moment factor m_{LT} must always be taken as 1.0. Cl. 4.3.6.6

7.7 Deflection

See guidance provided in Section 6.7.

7.8 Summary of design procedure

- | | |
|---|---------------|
| 1. Select section and steel grade | |
| 2. Determine design strength p_y | Table 9 |
| 3. Determine the section classification | Tables 11, 12 |
| 4. For Class 1 and Class 2 sections use the gross section properties | |
| 5. For Class 3 semi-compact sections calculate the effective plastic modulus | Cl. 3.6 |
| 6. For Class 4 slender sections calculate the effective elastic modulus | Cl. 3.6 |
| 7. Calculate local moment capacity allowing for shear, as for a restrained beam | Cl. 4.2.5 |
| 8. Determine actual unrestrained length and effective length | Cl. 4.3.5 |
| 9. Calculate slenderness $\lambda = L_e/r_y$ | Cl. 4.3.6.7 |
| 10. Determine the slenderness factor ν using λ/x | Table 19 |
| 11. Calculate β_w | Cl. 4.3.6.9 |
| 12. Calculate the equivalent slenderness λ_{LT} | Cl. 4.3.6.7 |
| 13. Determine p_b using λ_{LT} and the design strength p_y | Tables 16, 17 |
| 14. Calculate the buckling resistance moment M_b appropriate for the section classification | Cl. 4.3.6.4 |
| 15. Determine the equivalent uniform moment factor m_{LT} | Table 18 |
| 16. Check the maximum applied moment against the value of M_b/m_{LT} | Cl. 4.3.6.2 |
| 17. Calculate the deflections and check against appropriate limit. | Cl. 2.5.2 |

8 BEAM WEB DESIGN

8.1 Introduction

This section deals with two main web design issues:

- Webs subject to concentrated loads
- Openings in beam webs

8.2 Web subject to concentrated loads

8.2.1 Failure modes

When concentrated loads are applied through the flange to the web of a section, then checks on the beam web are required to determine whether or not stiffening is required. Web bearing failure or web buckling failure, as shown in Figure 8.1 can occur in thin webs under concentrated loads. Where the load is transferred directly to the beam web (e.g. by end plate, angle cleats or fin plate connections), web bearing and buckling checks are not required. Concentrated loads often occur at beam supports (i.e. the reactions) and when loads are transferred from other members sitting on the top flange of the beam under consideration.

Cl. 4.5

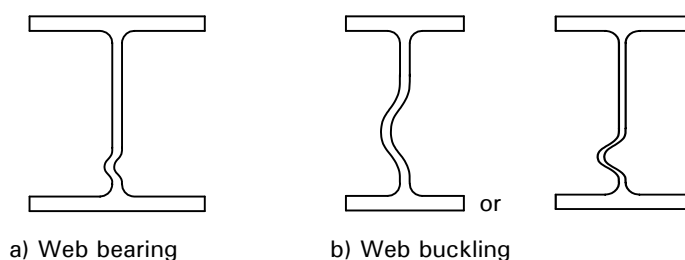


Figure 8.1 *Web failure modes*

8.2.2 Web bearing

A web bearing failure occurs when the bearing stress exceeds the yield strength of the section at the critical location. For design, the critical location is taken as the part of the web closest to the applied load, adjacent to the root radius.

The web bearing capacity is given by:

Cl. 4.5.2

$$P_{bw} = (b_1 + n k) t p_{yw}$$

where:

b_1 is the length of stiff bearing

$n = 5$, except at the end of a member

$n = 2 + 0.6 b_e/k$ but $n \leq 5$ at the end of a member

b_e is the distance from the end of the member to the nearer end of the stiff bearing, see Figure 8.2 (ii)

- $k = T + r$ for rolled sections
- $k = T$ for welded sections
- p_{yw} is the design strength of the web
- r is the root radius
- T is the flange thickness
- t is the web thickness

Dispersion of the load through the flange and root radius is allowed for in the calculation of the web bearing capacity. Figure 8.2 shows the assumed load dispersion, for four situations, for the web bearing check.

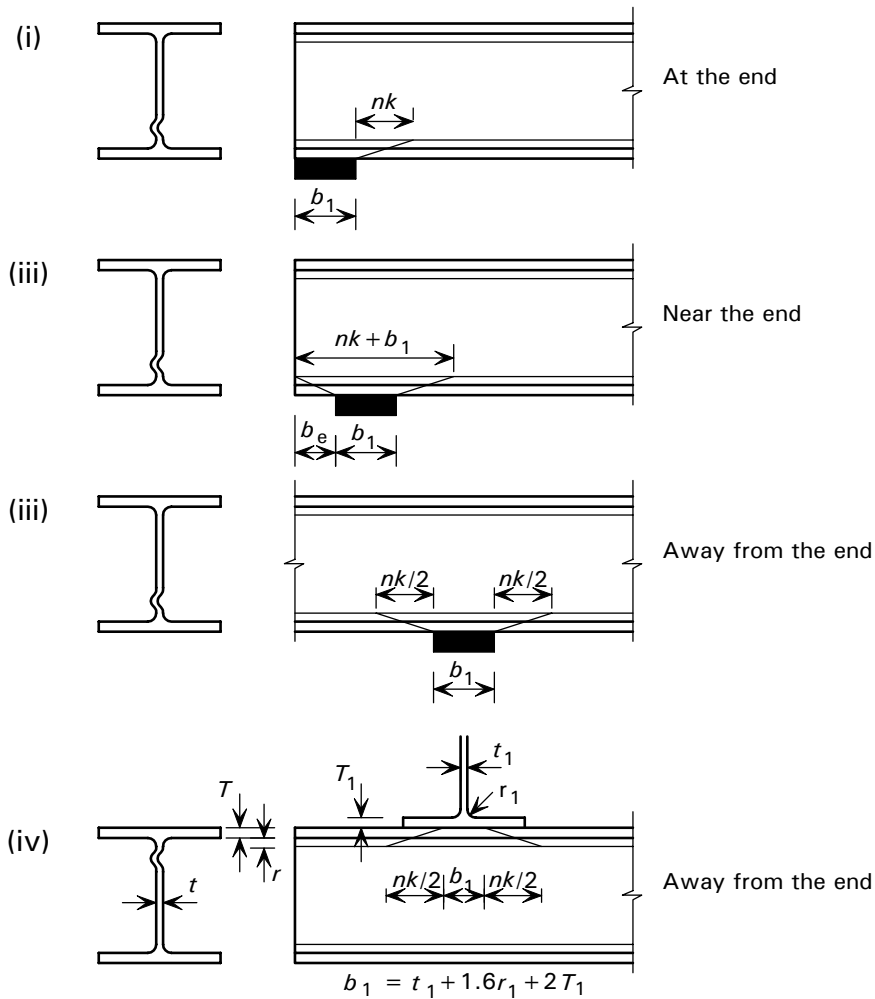


Figure 8.2 *Web bearing failure*

If the applied load is greater than the web bearing capacity P_{bw} , then a stiffener is required to carry the applied load less the capacity of the web. Detailed design of bearing stiffeners is covered in Section 13.

8.2.3 Web buckling

Web buckling failure is similar to column buckling subject to axial compression. The web should therefore be checked to ensure that the applied load does not exceed the buckling resistance of the web.

Cl. 4.5.3.1

The web buckling resistance is given by:

$$P_x = \frac{25 \varepsilon t}{\sqrt{(b_1 + nk)d}} P_{bw}$$

where:

$$\varepsilon = (275/p_{yw})^{0.5}$$

d is the depth of the web

All other terms are as defined in Section 8.2.2.

However, if the distance a_e (see Figure 8.3) from the load or reaction to the nearer end of the member is less than $0.7d$, then the buckling resistance should be multiplied by the reduction factor:

$$\frac{a_e + 0.7d}{1.4d}$$

The reduction factor allows for the fact that the dispersion of load can be restricted due to the proximity of the end of the member. Figure 8.3 shows a buckling failure and illustrates the definition of a_e .

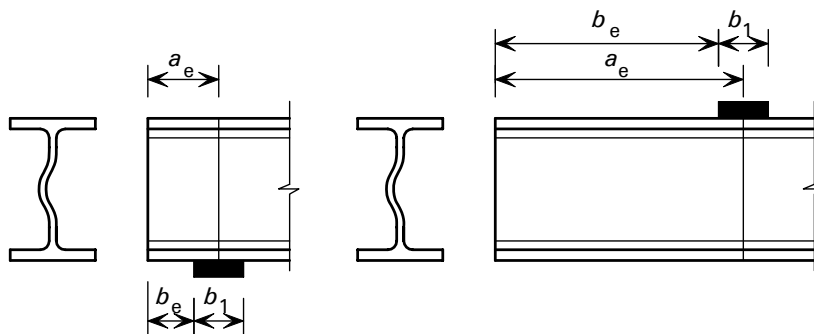


Figure 8.3 Web buckling failure

The web buckling check assumes that the flange through which the load or reaction is applied is effectively restrained against both:

- (a) Rotation relative to the web (see Figure 8.4(a))
- (b) Lateral movement relative to the other flange (see Figure 8.4(b))

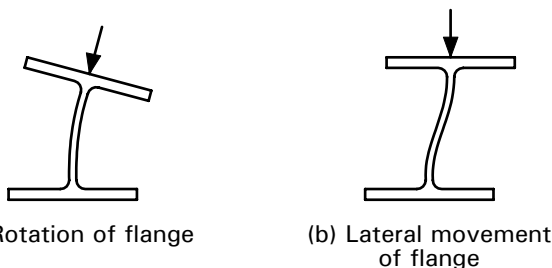


Figure 8.4 Unrestrained flanges

If either condition a) or b) is not met, then the buckling resistance should be reduced to P_{xr} , which is given by:

$$P_{xr} = \frac{0.7d}{L_E} P_x$$

where:

d is the depth of the web

L_E is the effective length of the web depending on the conditions of end restraints

As with web bearing, web buckling checks will be required at the supports and at the points in the length of the beam where loads are applied through the flange (as shown in Figure 8.3).

If the applied load exceeds the web buckling resistance, then a stiffener plus part of the web will be required to carry the applied load. Such stiffeners are described as load carrying stiffeners and are dealt with in detail in Section 13 covering the design of plate girders.

8.3 Openings in beam webs

8.3.1 Introduction

The code provides guidance on the effects and design of openings in beam webs. It is not intended that the rules be applied to holes for fastenings. However, allowance for fastener holes does need to be considered for tension members (see Section 4.3) and for shear at connections (see Section 11.2).

Cl. 4.15

For a beam with a rectangular opening in the web, as shown in Figure 8.5, the two T sections above and below the hole will be subject to axial tension and compression due to the overall moment on the beam, together with the secondary effects of the shear forces. The easiest way to check the member is to consider the top and bottom T sections as chords of a truss; the force is then simply the moment divided by the distance between the centroids of the tees. The shear is then carried by considering the T sections as fixed cantilevers from the solid section and there will be bending in these members due to this form of action.

When considering openings in webs, the following points must also be considered.

- The provision of stiffening around the opening
- The effect of openings on tension field action
- The effect of the openings on the stiffness of the member and on the deflections.

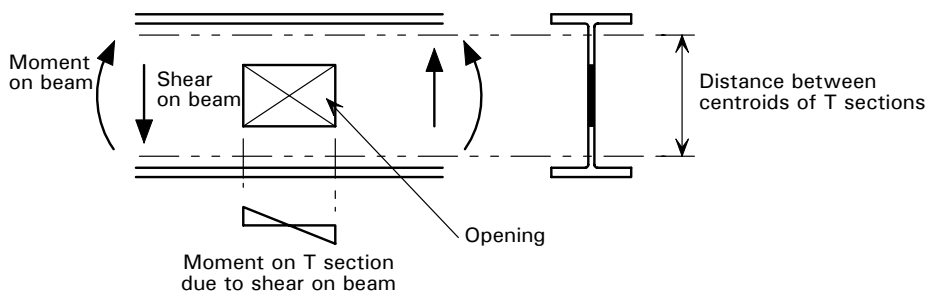


Figure 8.5 Forces at opening

8.3.2 Design requirements

The code specifically addresses four cases:

- Isolated circular openings
- Members with isolated openings
- Members with multiple openings
- Castellated beams.

Cl. 4.15.2

Cl. 4.15.3

Cl. 4.15.4

Cl. 4.15.5

In each of the above cases some guidance is given on the design problems, which although not fully comprehensive, reminds the designer of the basic requirements. The guidance provided is simple and conservative for normal design purposes. The code prohibits the use of tension field action in webs where there are substantial openings.

8.3.3 Isolated unreinforced circular openings

Clause 4.15.2.1 is provided to enable the beam to be checked easily when a few openings are present. The rules are not intended to apply in cases where the engineer carries out a detailed stress analysis of the section to justify its behaviour. The limitations on the use of such openings are that:

Cl. 4.15.2.1

- The member has a Class 1 plastic or Class 2 compact cross-section
- The cross-section has an axis of symmetry in the plane of bending
- The openings must be in the middle third of the depth and middle half of the span
- The minimum spacing between centres of adjacent openings must not be less than 2.5 times the diameter of the larger hole
- Any point loads present should not be applied closer to the centre of the hole than the depth of the member
- The loading is generally uniformly distributed and the shear due to any point load is less than 10% of the shear capacity
- The maximum shear in the member is limited to 50% of the shear capacity.

These requirements are illustrated in Figure 8.6. Outside these limits, members should be designed as described in Section 8.3.5.

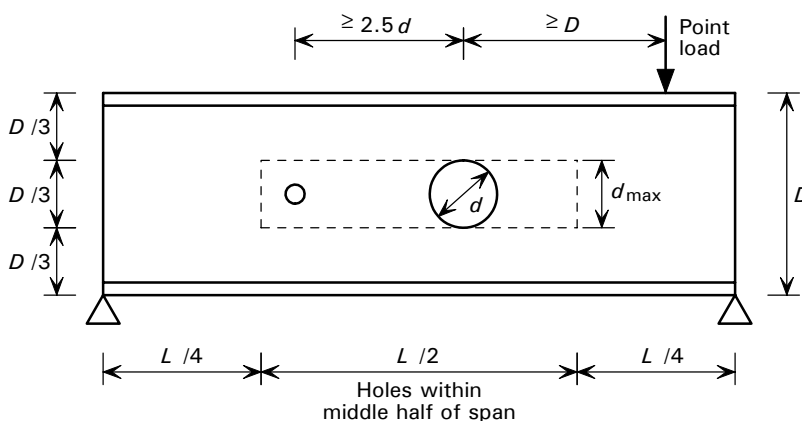


Figure 8.6 Requirements for unreinforced circular openings

8.3.4 Isolated reinforced circular openings

The limits from Section 8.3.3 can be very restrictive in everyday design, therefore provision has been made to allow reinforced openings. Clause 4.15.2.2 states that:

Web reinforcement may be provided adjacent to the opening to compensate for the material removed. It should be carried past the opening for such a distance such that the local shear stress due to force transfer between the reinforcement and the web does not exceed $0.6p_y$. Cl. 4.15.2.2

There are two types of reinforcement that are commonly used; these are shown in Figure 8.7.

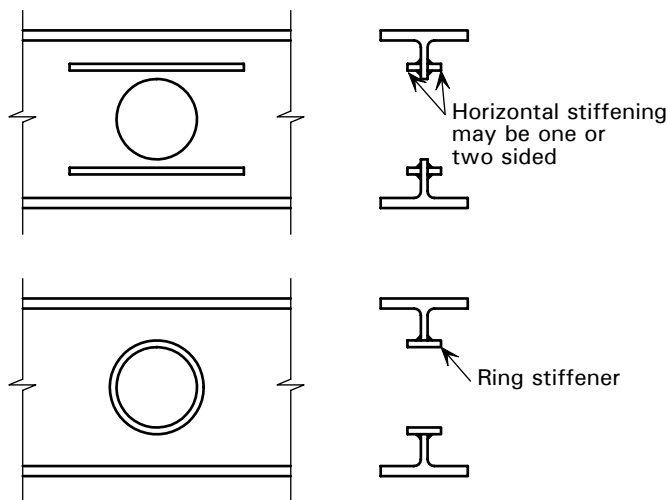


Figure 8.7 *Types of stiffening for circular openings*

8.3.5 Members with isolated openings

All members with isolated openings should also be checked for:

- (a) Local buckling of all compression elements
- (b) Shear at the net section across the opening
- (c) The need to provide load bearing stiffeners; stiffeners should be provided where point loads are closer to the opening than the overall depth of the member
- (d) Moment capacity, allowing for the effects of secondary Vierendeel moments due to shear at the web opening
- (e) The additional deflection due to the openings. (These deflections should be added to the primary deflection.)

Cl. 4.15.3

Additional guidance on the design of members with web openings is given in SCI publication P068^[32], which is also referenced in the code.

8.3.6 Members with multiple openings

The code provides general design rules for members with multiple openings. The rules cover local buckling, shear stress, moment capacity, buckling moment, deflection, resistance to concentrated loads and web post stability. For most of these checks the code refers to earlier clauses of the code (which are covered in previous sections of this publication).

Cl. 4.15.4

8.3.7 Castellated beams

Specific rules relating to castellated beams as shown in Figure 8.8 are given in the Code and in SCI publication P005^[33]. The Code states that:

In the case of castellated beams with the standard proportions as shown in Figure 16 of BS 5950-1, reproduced here as Figure 8.8, fabricated from rolled I, H or from channel sections, it may be assumed that the web posts are stable provided that the ratio d/t for the web of the expanded cross-section does not exceed 70ε .

Cl. 4.15.5

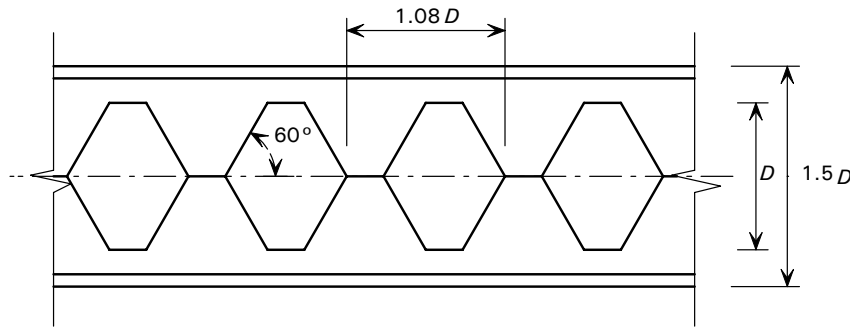


Figure 16

D is the serial size and not the depth of the original section

Figure 8.8 Standard proportions of castellated beams

8.3.8 Cellular beams

The design of cellular beams is not specifically covered in the Code. However, the SCI publication *Design of composite and non-composite cellular beams*^[34] provides comprehensive design guidance and is referenced in the Code.

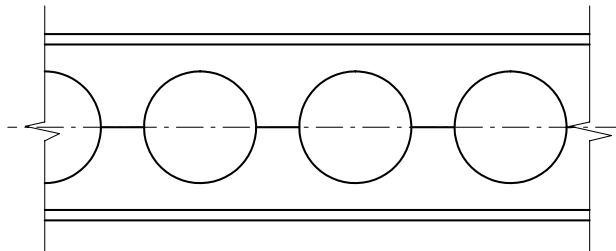


Figure 8.9 Cellular beams

9 MEMBERS SUBJECT TO AXIAL LOAD AND BENDING

9.1 Introduction

Cl. 4.8

Situations will often arise in which the loading on a member cannot reasonably be represented as a single dominant effect. Such problems require an understanding of the way in which the various structural actions interact with one another. In the simplest of cases, this may account to nothing more than a direct summation of 'unity' factors (e.g. applied axial load/axial resistance plus applied moment/moment capacity). Alternatively, for more complex problems, careful consideration of the complicated interaction between individual load components and the resulting deformations is necessary.

The design of members subject to axial load and bending is influenced by the method of frame analysis, the shape of the cross-section used and the type of restraint provided.

In order to perform satisfactorily, the combined effects of axial load and bending must not cause the member to fail due to:

- Local buckling
- Inadequate cross-section capacity
- Overall member buckling.

Therefore, a member subject to axial load and bending must be checked for each of these failure modes.

The design approach discussed in this section is intended for use in situations where a single member is to be designed for a known set of end moments and forces. The special case of columns in 'simple construction', is covered in Section 10.

The additional complexity of buckling associated with compressive loads means that it is more convenient to discuss the cases of tension plus bending and compression plus bending separately.

9.2 Section classification

In order to ensure that a member does not fail due to local buckling the cross-section should be classified and the design carried out according to the class of cross-section.

Classification of sections is discussed in Section 3.

9.3 Tension members with moments

9.3.1 Cross-section capacity

Figure 9.1 illustrates the type of three-dimensional interaction failure envelope that controls the ultimate strength of steel members under combined biaxial bending and tension. Each axis represents a single load component, F , M_x or M_y . Two failure envelopes are illustrated, one a simple plane surface (the 'simplified method') and one a doubly curved surface that generally lies further from the origin (the 'more exact method'). Both envelopes intersect the individual axes at points that represent the member's capacity under that form of load acting singly. The exact shape of the surface shown by the dashed lines will depend upon the cross-section for which the diagram is constructed, in particular the scope for redistribution of stress beyond first yield. Any point on the failure envelope represents a limiting load combination that can be carried, according to the appropriate method.

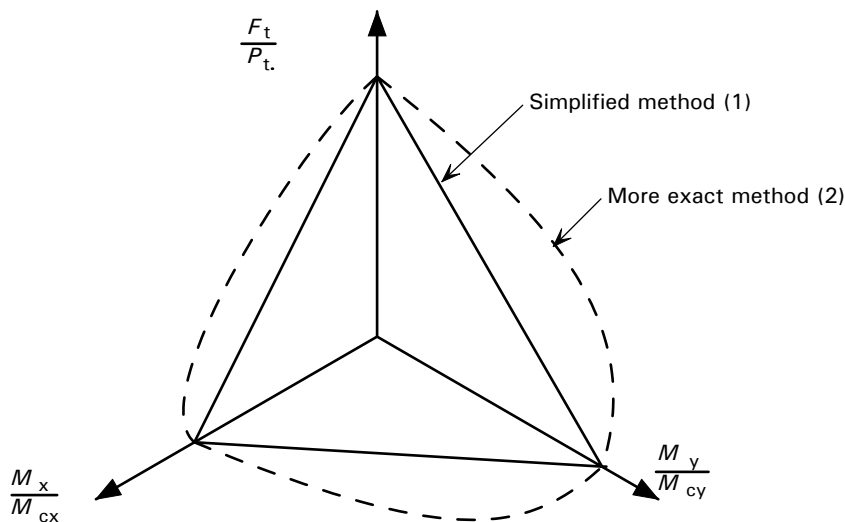


Figure 9.1 Simple and more exact failure envelopes for strength under combined loading

Simplified method

The simplified method of BS 5950-1:2000 is expressed as:

$$\frac{F_t}{P_t} + \frac{M_x}{M_{cx}} + \frac{M_y}{M_{cy}} \leq 1 \quad (1)$$

where:

- F_t is the axial tension at the critical location
- P_t is the tension capacity of the section
- M_x is the moment about the major axis at the critical location
- M_{cx} is the moment capacity about the major axis of the section
- M_y is the moment about the minor axis at the critical location
- M_{cy} is the moment capacity about the minor axis of the section.

Cl. 4.8.2.2

The expression should be evaluated at the critical location within the member, which is usually where the moments and/or the forces are largest. This is a linear interaction in which each of the three terms has equal weighting. Figure 9.1 shows how the interaction tends towards the previously derived design conditions for the component cases as one form of loading becomes dominant.

The interaction expression above is based on the simple assumption that the stresses due to axial load and moments are additive, as shown in Figure 9.2. Thus, for an elastic distribution, the cross-section capacity is reached when the total stress at an extreme fibre reaches the yield stress of the member. For plastic distribution, the cross-section capacity of the section is reached when the stress throughout the section equals the yield stress of the member. The stress distributions due to the moments are those that are appropriate for the class of section (see Section 3.2).

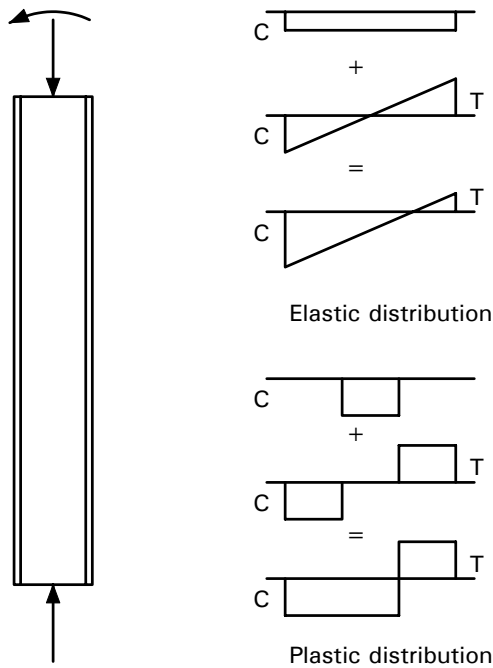


Figure 9.2 Stress due to axial load and bending

More exact method

Alternatively, there is a more exact method that may be used for tension members with moments. For Class 1 plastic and Class 2 compact sections, more sophisticated analysis of this problem using the principles of plastic theory has shown that for such classes of section, the following expressions may be used:

For tension members with major axis moments only:

$$M_x \leq M_{rx}$$

For tension members with minor axis moments only:

$$M_y \leq M_{ry}$$

For tension members with doubly-symmetric cross-sections subject to biaxial moments:

$$\left[\frac{M_x}{M_{rx}} \right]^{z_1} + \left[\frac{M_y}{M_{ry}} \right]^{z_2} \leq 1 \quad (2)$$

where:

M_x is the moment about the major axis at the critical location

M_{rx} is the reduced moment capacity in the presences of axial force about the major axis

M_y is the moment about the minor axis at the critical location

M_{ry} is the reduced moment capacity in the presences of axial force about the minor axis of the section

z_1 and z_2 are empirical constants, see Table 9.1.

Table 9.1 z_1 and z_2 values

| Section type | z_1 | z_2 |
|--------------------------------------|-------|-------|
| I and H sections with equal flanges | 2.0 | 1.0 |
| Solid or hollow circular sections | 2.0 | 2.0 |
| Solid or hollow rectangular sections | 5/3 | 5/3 |
| All other cases | 1.0 | 1.0 |

The advantage of using the more exact method is that the interaction is non-linear and therefore the calculations give a larger cross-section capacity. The difference between the simple and the more exact methods is shown graphically in Figure 9.1.

The more exact method cannot be used with singly symmetric or non-symmetric sections subject to biaxial moments and axial tension.

Reduced moment capacity

The reduced moment capacities M_{rx} and M_{ry} are the moment capacities of Class 1 plastic and Class 2 compact sections allowing for the axial load applied to the member.

$$M_{rx} = p_y S_{rx}$$

$$M_{ry} = p_y S_{ry}$$

where:

p_y is the member design strength

S_{rx} is the reduced plastic modulus about the major axis

S_{ry} is the reduced plastic modulus about the minor axis.

The reduced plastic modulus of the section is the plastic modulus of the area remaining after deduction of an area that is just sufficient to carry the axial load. Figure 9.3 shows the effective section for this purpose and gives expressions for calculating the reduced plastic modulus about the major axis for an H section with equal flanges and low axial load (i.e. assuming the axial load can be carried by the web).

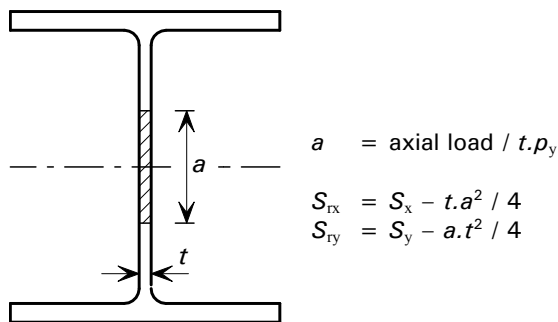


Figure 9.3 Reduction in plastic modulus due to axial load

Formulae for calculating the reduced plastic modulus for both the major and minor axis are given in the code. Values of S_{rx} and S_{ry} for rolled sections for varying values of axial load are tabulated in section properties tables, see SCI publication P202^[26].

Annex I.2

9.3.2 Member buckling resistance

Axial tension in a member will assist in preventing a lateral torsional buckling due to the bending in the member. Theoretically it should be possible to take account of this beneficial effect, but the expressions involved are complex and it would be difficult to ensure that the correct combination of tension and bending is used to ensure the worst effect. Therefore the code simply requires that the bending effects be checked in isolation and the member treated as a laterally unrestrained member. This is to be carried out even when the tension and bending effects cannot occur independently. The design procedure for this is as described in Section 7.

Cl. 4.8.2.1

9.4 Compression members with moments

9.4.1 General

Compression members with moments must be checked for cross-section capacity and member buckling resistance.

Cl. 4.8.3.1

Compression members that are subject to nominal moments (i.e. moments due to the eccentricity of load applied at the connections, for example columns in simple structures) should be designed in accordance with Section 10.

Cl. 4.7.7

9.4.2 Cross-section capacity

Simplified method

The simplified method for compression members with moments is very similar to the simplified method for tension members with moments, the one difference being that for Class 4 slender sections the capacities (axial and bending) are based on the effective section area.

For compression members the following expressions should be satisfied.

Cl. 4.8.3.2

For non slender members (i.e. Class 1, 2 or 3)

Cl. 4.8.3.2

$$\frac{F_c}{A_g p_y} + \frac{M_x}{M_{cx}} + \frac{M_y}{M_{cy}} \leq 1$$

For Class 4 slender members

$$\frac{F_c}{A_{\text{eff}} p_y} + \frac{M_x}{M_{\text{cx}}} + \frac{M_y}{M_{\text{cy}}} \leq 1$$

where:

p_y is the member design strength

A_g is the gross area of the cross-section

A_{eff} is the effective area of the cross-section

All other symbols are as defined in Section 9.3.1.

These expressions should be satisfied for the critical locations of the member i.e. where the axial loads and bending moments are greatest.

More exact method

Alternatively, for Class 1 plastic and Class 2 compact cross-sections, the more exact method, as described in Section 9.3.1, may be used.

9.4.3 Member buckling resistance

The code again gives two methods for checking the member buckling resistance; a simplified method and a more exact method.

Simplified Method

Compression members with moments can be checked for member buckling resistance by using two interaction formulae. The first expression deals with buckling generally and the second with buckling about the minor axis.

$$\frac{F_c}{P_c} + \frac{m_x M_x}{p_y Z_x} + \frac{m_y M_y}{p_y Z_y} \leq 1 \quad (3)$$

$$\frac{F_c}{P_{cy}} + \frac{m_{LT} M_{LT}}{M_b} + \frac{m_y M_y}{p_y Z_y} \leq 1 \quad (4)$$

where:

F_c is the applied axial compression

P_c is the minimum of P_{cx} and P_{cy}

P_{cx} is the compression resistance considering buckling about the major axis only

P_{cy} is the compression resistance considering buckling about the minor axis only

M_x is the maximum major axis moment within the segment length L_x governing P_{cx}

M_y is the maximum minor axis moment within the segment length L_y governing P_{cy}

M_{LT} is the maximum major axis moment within the segment length L governing M_b

Z_x is the elastic section modulus about the major axis, $Z_{x,\text{eff}}$ should be used for Class 4 slender sections

Cl.
4.8.3.3.1

Z_y is the elastic section modulus about the minor axis, $Z_{y,eff}$ should be used for Class 4 slender sections

m_x , m_y and m_{LT} are uniform moment factors, which take account of the shape of the bending moment diagram between restraints (see later).

The first of the two interaction expressions (3) is a combination of the following expressions, (5) and (6), relating to buckling about the major axis due to axial compression and major axis bending (5) and to buckling about the minor axis due to axial compression and minor axis bending (6).

$$\frac{F_c}{P_{cx}} + \frac{m_x M_x}{p_y Z_x} \leq 1 \quad \text{for major axis bending} \quad (5)$$

$$\frac{F_c}{P_{cy}} + \frac{m_y M_y}{p_y Z_y} \leq 1 \quad \text{for minor axis bending} \quad (6)$$

The second expression (4) in this Section checks buckling about the minor axis due to axial compression, major axis bending and minor axis bending.

This form of buckling is analogous to lateral torsional buckling in beams. The column buckles in a mode involving twisting and minor axis bending. The twisting mode distinguishes it from minor axis buckling and reduces the buckling load. It is significant for I and H sections that buckle at low axial loads. It is generally not relevant for tubular sections, apart from rectangular hollow sections with a large depth to width ratio.

In this case the value of P_{cy} is specifically used as we are considering buckling about the minor axis. Figure 9.4 shows the differences between in-plane and out-of-plane buckling.

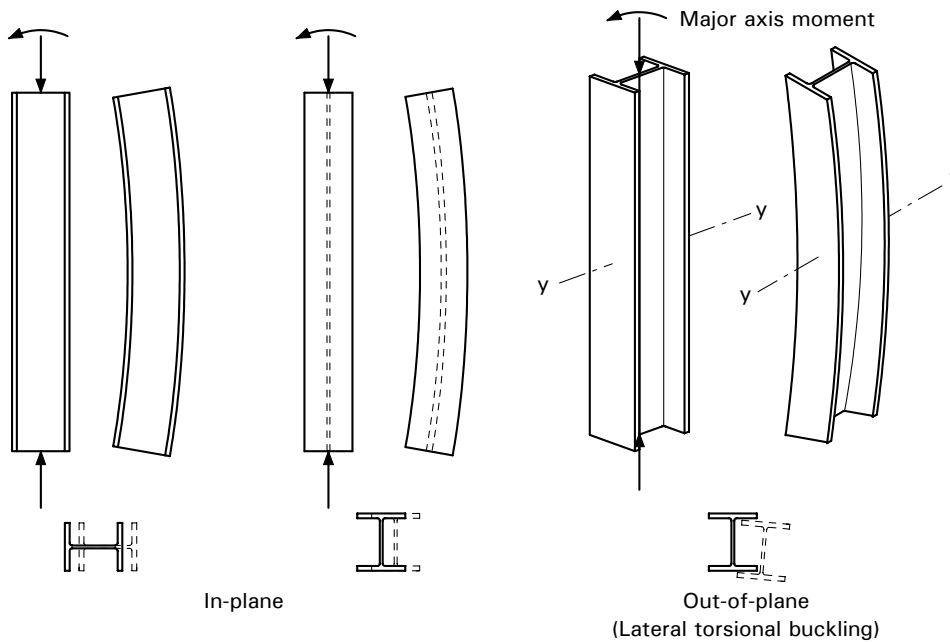


Figure 9.4 Buckling modes for members subject to axial compression and bending

More exact method

For I and H sections, CHS, RHS and box sections with equal flanges, the code offers a more exact method. The basis of design is same in that there are interaction expressions that must be satisfied.

The more exact interaction expressions include terms additional to those in the simplified method. The additional moment created by the axial load at an eccentricity δ is allowed for as shown in Figure 9.5.

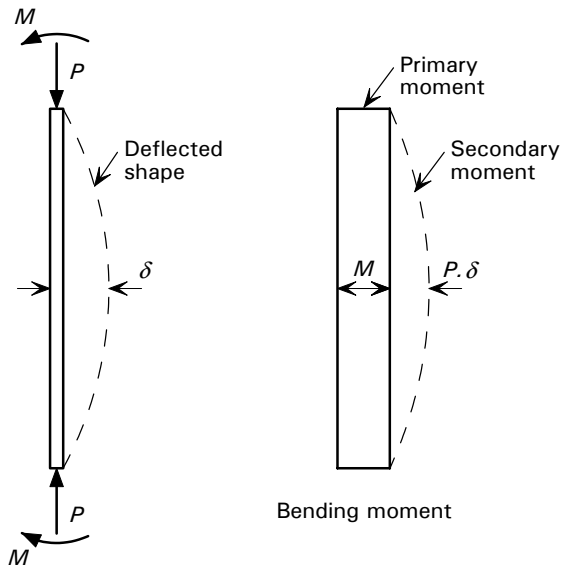


Figure 9.5 More exact consideration of moments

In the vast majority of cases, the simplified method is sufficiently accurate to produce economic designs. The more exact method should only be needed when extra capacity is required, possibly resulting from additional loading that was not originally considered.

Equivalent uniform moment factors

The equivalent uniform moment factors m_x , m_y , m_{xy} and m_{LT} take account of the shape of the bending moment diagram between restraints. These factors are required because the theory is based on members subject to a uniform moment, which is the worst case. Therefore, the uniform moment factors can conservatively be taken as 1.0 for all cases.

The interaction expressions for compression members with moments contain two types of equivalent uniform moment factor: m_x , m_y and m_{yx} for flexural buckling and m_{LT} for lateral torsional buckling. For any given bending moment diagram, the values of these factors for flexural buckling and lateral torsional buckling are different.

The equivalent uniform moment factor for lateral torsional buckling is described in Section 7.6 and can be obtained from Table 7.2.

The equivalent uniform moment factors for flexural buckling (m_x , m_y , and m_{xy}) are obtained from Table 26 of BS 5950-1, reproduced here as Table 9.2. If there is bending about both axes, equivalent uniform moment factors are required for each axis and are likely to have different values.

Cl.
4.8.3.3.2
Cl.
4.8.3.3.3

Cl.
4.8.3.3.4

For sway sensitive frames (see Section 1.6.3) there are additional rules to be applied regarding the use of equivalent uniform moment factors. If sway mode in-plane effective lengths (see Section 5.3) are used, the flexural buckling equivalent uniform moment factors must not be taken as less than 0.85. If amplified sway moments (see Table 1.5) are used, the flexural buckling equivalent uniform moment factors for that plane must only be multiplied by the non-sway moments. For this case the simplest solution may be to take the equivalent uniform moment factor as unity.

Additional guidance on equivalent uniform moment factors can be obtained from advisory desk articles AD109^[35] and AD251^[36].

9.5 Summary of design procedure

9.5.1 Tension members with moments

- | | |
|---|--------------------------|
| 1. Select section and steel grade | |
| 2. Determine design strength | Table 9 |
| 3. Determine section classification | Table 11 Table 12 |
| 4. For Class 1 and Class 2 sections use gross section properties | |
| 5. For Class 3 semi-compact sections calculate the effective plastic modulus | Cl. 3.6 |
| 6. For Class 4 slender sections calculate the effective elastic modulus | Cl. 3.6 |
| 7. Evaluate the cross-section capacity interaction expressions. Check that the result does not exceed unity. | Cl. 4.8.2.2 |
| 8. If the result is slightly greater than unity and the section is Class 1 or Class 2 calculate the reduced moment capacity in the presence of axial force and try using the more exact method for cross-section capacity. Check that the result does not exceed unity. | Cl. 4.8.2.3 Annex I.2 |
| 9. Check the member buckling resistance. Ignore the tensile axial load and design as an unrestrained beam. | Cl. 4.3.6 |

9.5.2 Compression members with moments

- | | |
|---|--------------------------|
| 1. Select section and steel grade | |
| 2. Determine design strength | Table 9 |
| 3. Determine section classification | Table 11 Table 12 |
| 4. For Class 1 and Class 2 sections use gross section properties | |
| 5. For Class 3 semi-compact sections calculate the effective plastic modulus | Cl. 3.6 |
| 6. For Class 4 slender sections calculate the effective elastic modulus and the effective area if subject to compression | Cl. 3.6 |
| 7. Evaluate the cross-section capacity interaction expressions. Check that the result does not exceed unity. | Cl. 4.8.3.2 |
| 8. If the result is slightly greater than unity and the section is Class 1 or Class 2 calculate the reduced moment capacity in the presence of axial force and try using the more exact method for cross-section capacity. Check that the result does not exceed unity. | Cl. 4.8.2.3 Annex I.2 |

Table 9.2 Equivalent uniform moment factors for flexural buckling

Table 26

| Segments with end moments only (m from formula for the general case) | β | m |
|--|---------|------|
| <div style="display: flex; justify-content: space-around;"> <div style="text-align: center;"> <p>β positive</p> </div> <div style="text-align: center;"> <p>β negative</p> </div> </div> | 1.0 | 1.00 |
| | 0.9 | 0.96 |
| | 0.8 | 0.92 |
| | 0.7 | 0.88 |
| | 0.6 | 0.84 |
| | 0.5 | 0.80 |
| | 0.4 | 0.76 |
| | 0.3 | 0.72 |
| | 0.2 | 0.68 |
| | 0.1 | 0.64 |
| | 0.0 | 0.60 |
| | -0.1 | 0.58 |
| | -0.2 | 0.56 |
| | -0.3 | 0.54 |
| -0.4 | 0.52 | |
| -0.5 | 0.50 | |
| -0.6 | 0.48 | |
| -0.7 | 0.46 | |
| -0.8 | 0.44 | |
| -0.9 | 0.42 | |
| -1.0 | 0.40 | |

| Segments between intermediate lateral restraints | |
|---|--|
| Specific cases | General case |
| <p>$m = 0.90$</p> | <div style="display: flex; justify-content: space-around;"> </div> $m = 0.2 + \frac{0.1M_2 + 0.6M_3 + 0.1M_4}{M_{\max}} \text{ but } m \geq \frac{0.8M_{24}}{M_{\max}}$ <p>The moments M_2 and M_4 are the values at the quarter points and the moments M_3 is the value at mid length.</p> <p>If M_2, M_3 and M_4 all lie on the same side of the axis, their values are all taken as positive. If they lie on both sides of the axis, the side leading to the larger value of m is taken as the positive side.</p> <p>The values of M_{\max} and M_{24} are always taken as positive. M_{\max} is the maximum moment in the segment and M_{24} is the maximum moment in the central half of the segment.</p> |
| <p>$m = 0.95$</p> | |
| <p>$m = 0.95$</p> | |
| <p>$m = 0.80$</p> | |
| <p>Note: The applied point loads and the UDL provide no lateral restraint to the beam</p> | |

| | BS 5950-1 |
|---|----------------------|
| 9. Determine the compression resistance for buckling about the major axis and the minor axis. | Cl. 4.7.4 |
| 10. Determine the buckling resistance moment and the maximum major axis moment within the segment length. | Cl. 4.3.6 |
| 11. Determine values of the equivalent uniform moment factors. | Table 18 Table 26 |
| 12. Check the member buckling resistance. Evaluate the simplified method interaction expressions and check that the results do not exceed unity. | Cl. 4.8.3.3.1 |
| 13. If a result is slightly greater than unity and the section is doubly symmetric try using the more exact method for member buckling resistance. Check that the result does not exceed unity. | Cl. 4.8.3.3.2 |

10 COLUMNS IN SIMPLE STRUCTURES

10.1 Introduction

The basis of 'Simple structures' is to assume that that the structure is composed of members connected by nominally pinned joints, with resistance to horizontal forces being provided by bracing, shear walls or a lift core, as shown in Figure 10.1. The floor acts as a diaphragm to distribute horizontal load.

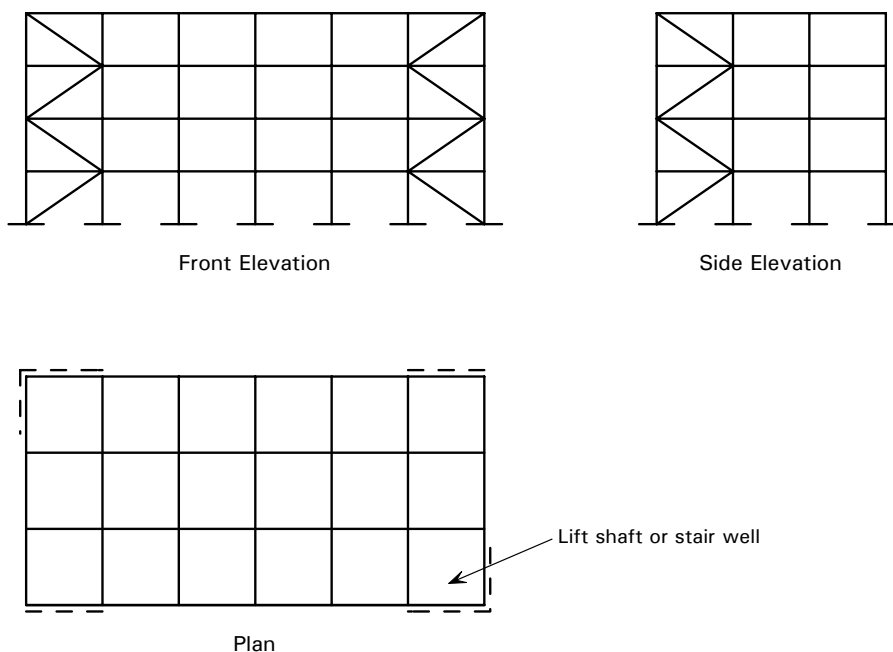


Figure 10.1 'Simple structure' with nominally pinned connections and bracing

This assumption makes the design of beams much easier, as bending moments and shear forces can be found by treating each beam as a simply supported beam.

Design of the columns however is not as straight forward. In multi-storey construction it is usual to use the same column size and weight through at least 2 storeys, to avoid the cost of splicing the columns. The columns are therefore continuous throughout a number of levels. A special set of rules exists in BS 5950-1 for continuous columns in simple construction. The beams are usually connected on the column face, producing some eccentricity of loading and in addition the connection will transfer some moment, however flexible the end connection. This moment will not affect the design of the beams but it will affect the column design.

In order to ensure that the connections behave nominally as pins (i.e. they transmit only small moments), care has to be taken to ensure that the connections are not too rigid, and this is generally achieved by the use of relatively thin web cleats, end plates or fin plates. Typical simple connections designed to carry shear only are shown in Figure 10.2.

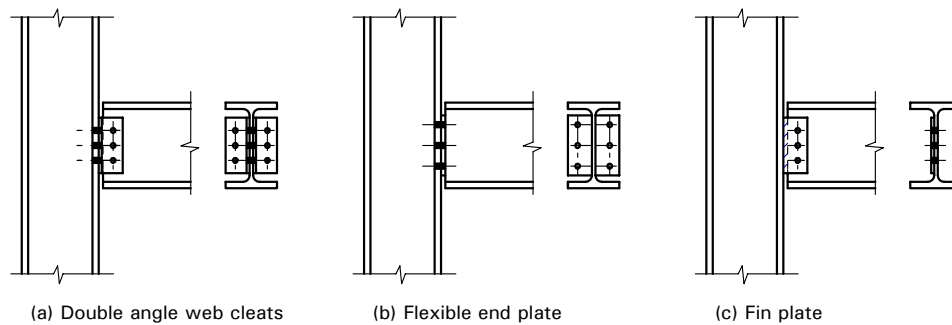


Figure 10.2 Typical 'simple' steel beam-to-column connections

Design of such connections is covered in Section 11. The following sections discuss the design of the columns when 'simple connections' are used.

10.2 Section classification

In most cases, columns in simple structures will be subject to predominantly axial loading and therefore the most efficient sections will be universal columns or structural hollow sections. Generally, these sections are not subject to local buckling. For a UC column in simple construction it is usually sufficient to check that the b/T of the flange does not exceed 15ε and that the d/t of the web does not exceed 40ε . If the section satisfies these checks, it is not Class 4 slender and the axial capacity can be based on the gross section area (see Section 5.1).

10.3 Column moments

The connection of beams to the columns will generate a moment in the column, due to the eccentricity of the connection and also due to the stiffness of the connection against the end rotation of the beam. In order to allow for this, the code assumes that 'nominal moments' are introduced by the beam end reactions acting at an assumed eccentricity. This relieves the designer of the necessity of trying to calculate the actual moments in the column. Beam end reactions should be taken as acting at 100 mm from the face of the steel column or at the centre of stiff bearing, whichever gives the greater eccentricity, see Figure 10.3.

Cl. 4.7.7

The method of adopting 'nominal moments' is similar to that used in BS 449, which has been justified by experience and previous studies rather than experimental evidence. For this reason a simplified and safe interaction expression for columns in simple structures is presented in the code. The more exact approach given in the code Clause 4.8.3 should not be used for columns in 'simple structures'.

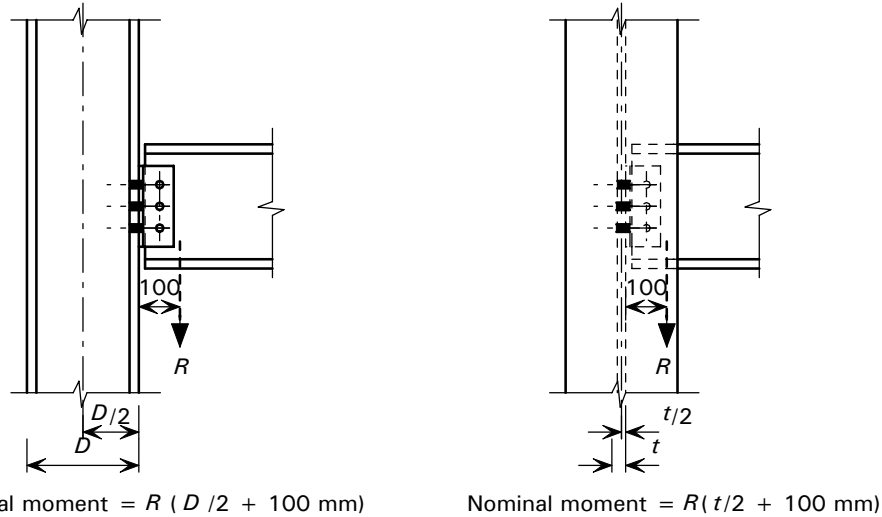


Figure 10.3 Calculation of nominal moments

10.3.2 Design moment

Having calculated the nominal moment at a particular level, the moments in the column above and below this level should then be calculated. This is done by assuming that the moment from a beam at any one level will be distributed up and down the column in proportion to the stiffness (I/L) of the columns above and below that level. In order to simplify matters even further, when the ratio of the stiffness of the more stiff length to the lesser stiff length is less than 1.5:1 the code allows these moments to be shared equally.

Cl. 4.7.7

For example consider the column shown in Figure 10.4.

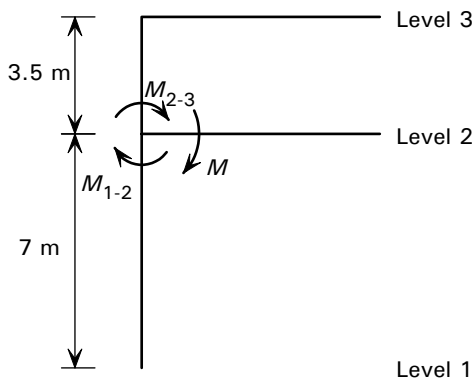


Figure 10.4 Column with varying stiffness

The stiffness of the column between levels 1 and 2 is equal to $I/7$ and between levels 2 and 3 is equal to $I/3.5$. Assuming that the value of I for the upper and lower column sections is the same, the ratio of the stiffnesses can be calculated as:

$$\text{Ratio} = \frac{I / 3.5}{I / 7} = \frac{7}{3.5} = 2 > 1.5$$

The moment must therefore be distributed in proportion to the stiffness.

$$M_{1-2} = M \left(\frac{I / 7}{I / 7 + I / 3.5} \right) = M \left(\frac{1}{3} \right)$$

$$\text{Similarly, } M_{2-3} = M \left(\frac{2}{3} \right)$$

Note that the shorter (and therefore stiffer) length carries the larger moment.

The nominal moments should be assumed to have no effect at the levels above and below the level at which they are applied.

10.4 Effective length of columns

The effective length for calculating the compression resistance P_c will depend on the degree of restraint provided by the incoming beams and the connections. The code leaves this decision to the designer, simply giving Table 22 to determine what effective lengths to use when the degree of restraint has been decided. Typically the values used are $0.85L$ or $1.0L$, depending on the size of the beams connecting to the column (where L is the distance between floor levels).

Cl. 4.7.3(b)
Table 22

It is possible that the effective length of the column about its two principal axes will be different, because the position and type of restraint provided to the axes may be different. The effective length about the major axis could be longer than that about the minor axis if the member is restrained on the y-y axis by tie beams, cladding supports etc.

10.5 Slenderness

The slenderness λ of the column should be calculated from the appropriate effective length divided by the radius of gyration about the appropriate axis.

Cl. 4.7.2

10.6 Compressive strength

The compressive strength p_c will depend on the slenderness $\lambda_x (= L_{Ex} / r_x)$ or $\lambda_y (= L_{Ey} / r_y)$ and the appropriate strut curve. In cases where the major axis effective length is longer than that of the minor axis, care should be taken to calculate the value of p_c for both axes because major axis (x-x) buckling is checked using strut curve b and minor axis (y-y) buckling is checked using strut curve c for rolled H sections with flanges not greater than 40 mm thick.

Cl. 4.7.5

10.7 Buckling resistance

In calculating the buckling resistance moment M_{bs} for columns in simple construction, the code allows the value of the equivalent slenderness λ_{LT} to be calculated using the simplified expression given below rather than the more complex formula used for unrestrained beams ($\lambda_{LT} = uv\lambda$).

Cl. 4.7.7

$$\lambda_{LT} = 0.5 L / r_y$$

where:

- L is the distance between levels at which the column is laterally restrained in both directions
- r_y is the radius of gyration about the minor axis

This simpler expression for λ_{LT} takes into account the values of u , and v as well as the effective length factor and the shape of the bending moment diagram. For rolled sections the value of p_b is obtained from Table 16 of BS 5950-1 in the usual way. The value of the buckling resistance moment for simple columns is calculated as described in Section 7.4.3.

10.8 Interaction

To take account of the combined effects of axial loads and moments the following single interaction expression is used:

Cl. 4.7.7

$$\frac{F_c}{P_c} + \frac{M_x}{M_{bs}} + \frac{M_y}{p_y Z_y} \leq 1$$

where:

- F_c is the compressive force due to axial load
- P_c is the compression resistance
- M_x is the nominal moment about the major axis
- M_{bs} is the buckling resistance moment for simple columns
- M_y is the nominal moment about the minor axis
- p_y is the design strength
- Z_y is the elastic modulus about the minor axis.

For sections not subject to lateral torsional buckling, (i.e. circular and square hollow sections and rectangular hollow sections within the limiting value of L_E/r_y given in Table 15 of BS 5950-1) M_{bs} should be taken as equal to the moment capacity M_c of the cross-section.

10.9 Loads and forces

In general, the loading applied to a structure designed as a 'simple structure' is the same as any other structure i.e. loads from BS 6399^[9] and load factors from BS 5950-1 should be used. However, one important difference for the design of columns in simple structures is that it is not necessary to consider pattern loading. For the purpose of column design, all the beams supported by a column at any one level should be assumed to be fully loaded.

Theoretically, there is no reason why pattern loading should be neglected in simple structures and despite the fact that the code allows it to be ignored, it would be unwise to do so in situations where pattern loading was certain to occur as part of the function of the structure e.g. stacking of paper in a warehouse where one bay was intended to be left empty while the adjacent one is filled.

In common with all structures, the notional horizontal forces (NHF) given in Clause 2.4.2.4 should be applied at every roof and floor level in combinations that do not include wind loads. The NHF allow for eccentricity of vertical loading due to imperfections such as out-of-straightness and lack of plumb of the columns. Generally the NHF will be less than the wind load but for long narrow structures they may be more severe when considering forces along the longer length of the building.

10.10 Summary of design procedure

1. Select section and steel grade
2. Determine which column segment to check – usually the lowest in the continuous run
3. Calculate the maximum beam reactions due to both factored dead and imposed load at either end of the column length to be checked
4. Calculate the factored axial compression within the length due to all loads
5. Calculate the nominal moments applied to the column from the beams, based on the nominal eccentricities Cl. 4.7.7
6. Distribute the nominal moments in proportion to the stiffness of the column above and below the level under consideration. If the ratio of the stiffnesses is less than 1.5:1 then distribute the moment equally Cl. 4.7.7
7. Determine the maximum moments about each axis
8. Determine the section classification and section properties Table 11
Table 12
9. Determine effective lengths for axial compression Cl. 4.7.3(b)
Table 22
10. Calculate the slenderness for compression Cl. 4.7.2
11. Determine the compressive strength p_c and the compression resistance P_c (take the lesser value for buckling about each of the two axes) Cl. 4.7.5
Cl. 4.7.4
12. Calculate the equivalent slenderness for lateral torsional buckling λ_{LT} Cl. 4.7.7
13. Determine the bending strength p_b and the buckling resistance moment for simple columns M_{bs} Cl. 4.3.6.4
14. Check the column length under consideration using the interaction expression. Cl. 4.7.7

11 CONNECTIONS

11.1 General

11.1.1 Design assumptions

In general, the designer of a structure will either adopt Simple design (in which it is assumed the connections are nominally pinned, i.e. no significant moments are transferred across the joint) or Continuous design (in which it is assumed the connections are rigid and transfer moment between members). In some cases the designer may use Semi-continuous design and assume that the connections are semi-rigid, but this is relatively unusual. Typical beam-to-column nominally pinned connections are shown in Figure 11.1 and rigid connections are shown in Figure 11.2. The assumptions made about connection behaviour during the frame analysis must be consistent with the final connection details.

Cl. 2.1.2

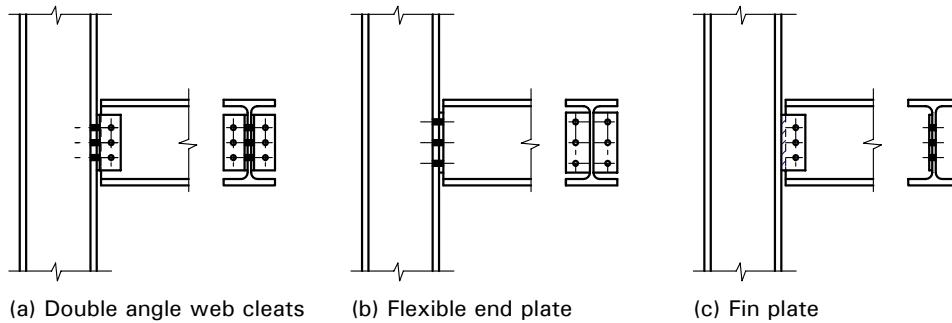


Figure 11.1 Typical beam-to-column pinned connections

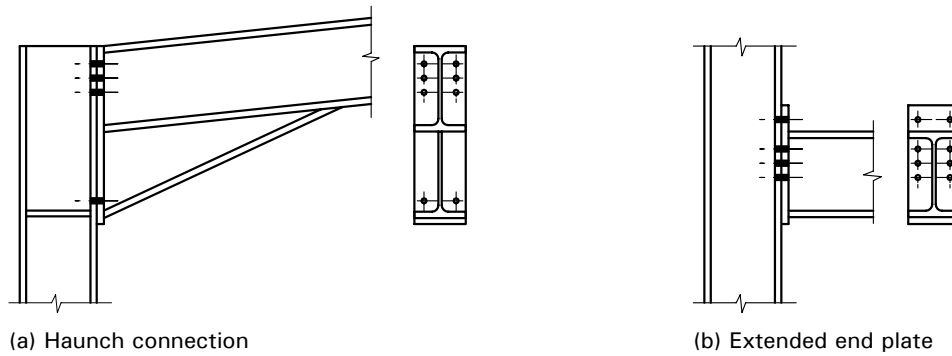


Figure 11.2 Typical beam-to-column rigid connections

The code requires that joints used in simple design should be capable of transmitting the calculated forces and should also be capable of accepting the resulting rotation. The connections must not transmit significant moments.

Cl. 6.1.4

In continuous design the connection must be capable of transmitting the forces and moments calculated in the global analysis.

Cl. 6.1.5

BS 5950-1 does not contain a design method for connections but presents information on the detailing requirements and the calculation of strength for individual components within a connection. Detailed design guidance and procedures are provided in the SCI Green book series of publications:

- *Joints in Steel Construction: Simple Connections*^[37]
- *Joints in Steel Construction: Moment Connections*^[38]
- *Joints in Steel Construction: Composite Connections*^[39].

It is recommended that those designing connections follow the guidance given in these publications, which is in accordance with the latest research and understanding of connection behaviour. Common types of connection have been analysed and the capacities tabulated for easy reference and the design of connections can be very much simplified by the use of these capacity tables.

11.1.2 Distribution of forces

BS 5950-1 states, “Joints should be designed on the basis of realistic assumptions of the distribution of internal forces”. This means that either elastic or plastic methods of design may be used, provided that the various elements of the connection are strong enough, stiff enough, and ductile enough, to accept the resultant forces and strains.

Cl. 6.1

Possible distributions of forces in an end plate moment resisting connection are shown in Figure 11.3. The value of compressive force must always equal the sum of the tensile forces. The design model assumed for the design of any connection must be applied consistently for the design of each element.

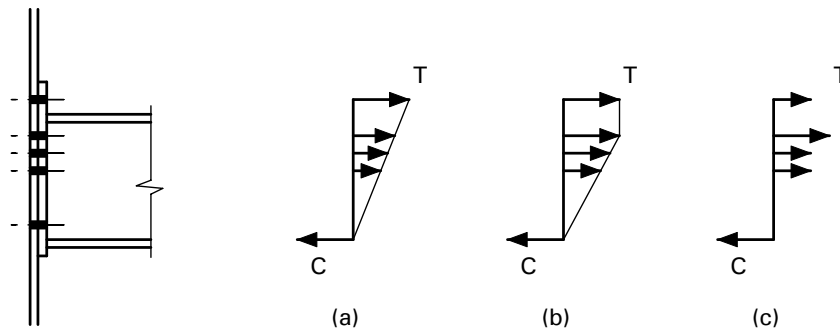


Figure 11.3 Possible distributions of bolt forces within a moment connection

11.1.3 Detailing

The detailing should ensure that the connection is capable of resisting the forces applied, within acceptable deformation limits and take account of tolerances and lack of fit. The connection detailing should be such that eccentricities between the lines of action of the forces within the connection are reduced. Figure 11.4 and Figure 11.5 show examples of connection eccentricities. Where eccentricities exist they must be accounted for in the connection design. In the case of angles, channels and T sections, the intersection of the setting out lines of the bolts may be adopted instead of the intersection of the centroidal axis. The two options are shown in Figure 11.4.

Where structural hollow sections are used, limited eccentricity should be introduced, where necessary, to suit other features of the connection design (i.e. a gap or an overlap as shown in Figure 11.5).

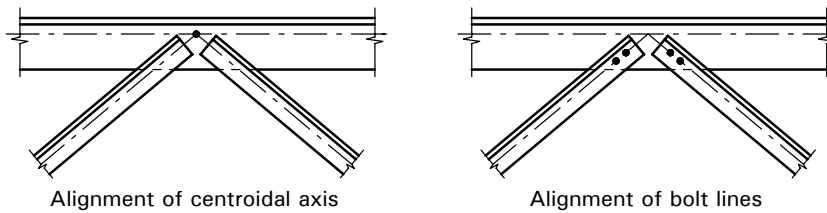
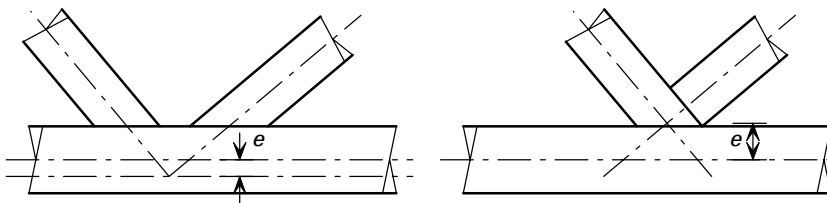


Figure 11.4 *Intersection of axes*



Gap joint with negative eccentricity Gap joint with positive eccentricity

Figure 11.5 *Eccentricity in rectangular hollow section connection*

11.1.4 Connection economy

Different situations will be best served by different types of connection. Each fabricator will have slightly different equipment, experience, workload and standards. Therefore cost of fabrication will vary. A number of simple rules can be applied however:

- Rigid connections generally cost considerably more than nominally pinned connections due to the additional work involved in fabrication and erection.
- Connections which require a large amount of stiffening will be much more expensive than those which do not. It may be more economical to make the members slightly heavier than it is to provide expensive stiffening at the connection.
- Connections that require special jigs to fabricate, such as complex welded connections, will be relatively expensive.
- Site welded connections are generally regarded as being relatively expensive because of the special facilities required, for storage of welding rods and for the welding process itself. Further guidance is given in P161 *Guide to site welding*^[40].

11.1.5 Splices

Splices should be designed to hold connected members in place. Where the centroidal axes of the splice and the connected members do not coincide the resulting moments, forces, deflections and rotations must be considered in the design.

Cl. 6.1.8.1

Ideally a splice in a compression member, or laterally unrestrained beam should be positioned close to a restraint. If this is not possible then the splice should be:

Cl. 6.1.8

- (a) Stiff enough to avoid reducing the buckling resistance of the member

(b) Strong enough to resist the forces and moments in the member

To satisfy the stiffness requirement (a) it is normal practice is to use flange and web cover plates, rather than end plate splices and to make the inertia of the splice material at least as great as that of the members, considering both axes.

Where significant net tension may be present or slip is unacceptable, preloaded HSFG bolts should be used and the splice should be designed to prevent slip under factored loads, i.e. $P_{sL} = 0.9 K_s \mu P_o$ (see Table 11.3). Situations where joint slip may be unacceptable include splices in a braced bay subjected to large load reversals.

Splice connections should be checked for the following effects:

- Moments due to strut action
- Moments due to Lateral Torsional Buckling
- Moments due to amplification effects

Annex C.3

Annex B.3

Annex I.5

Advisory desk articles AD243^[41] and AD244^[42] provided additional guidance on the design of splices in unrestrained members.

11.1.6 Column web panel zone

The column web panel zone is the subject to high local shear force. Figure 11.6 shows three examples of moment-resisting joints between a beam (or rafter) and column, with the column web panel zones shaded, irrespective of whether the column web is stiffened. Within the column web panel zone, the local shear force F_{vp} , due to the moment transfer, should be taken in to account.

Cl. 6.1.9

For a bolted joint the local shear force is obtained from:

$$F_{vp} = \sum F_{ri}$$

For a welded joint with a single beam, the local force shear due to moment transfer should be taken as:

$$F_{vp} = M_{tra} / (D_b - T_b)$$

where:

D_b is the beam depth

M_{tra} is the moment transferred from the beam to the column

T_b is the beam flange thickness

F_{ri} is the bolt force in row i of the tension zone.

Where more than one beam is connected to the column, the shear in the web panel zone should be taken as the net shear taking account of moment in both beams.

For a bolted joint, high local shear forces in the web panel zone do not reduce the moment capacity of the column.

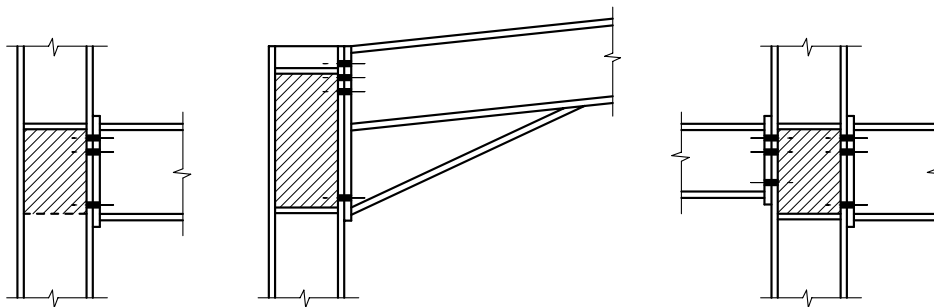


Figure 11.6 Examples of column web panel zones

For a welded joint, the moment capacity of the column is not reduced to allow for the effect of shear, provided that $F_v/P_v \leq 0.8$. Full shear capacity P_v can be developed in the column provided that the moment in the column does not exceed the elastic moment capacity $p_y Z$.

11.2 Bolted connections

11.2.1 Fasteners

Assemblies of bolts, nuts and washers should correspond to ‘matching assemblies’ as given in Table 2 of BS 5950-2^[1].

The types of bolt commonly used in UK construction are:

- Non-preloaded bolts (Grade 4.6 and Grade 8.8)
- Preloaded High Strength Friction Grip (HSFG) bolts

To reduce errors on site, the mixing of different grades of bolts of the same diameter on any one project should be avoided.

Strength grade designation

The grade of non-preloaded bolts is given by two figures separated by a point e.g. 4.6 and 8.8. The first number is a tenth of the minimum ultimate strength expressed in kgf/mm^2 and the second is ten times the ratio of minimum yield strength to minimum ultimate strength. Thus, multiplying the two numbers together gives the yield strength in kgf/mm^2 .

4.6 Bolts

Grade 4.6 bolts are generally used only for fixing lighter components such as purlins or sheeting rails, when 12 mm or 16 mm bolts may be adopted. Holding down bolts are also often grade 4.6.

8.8. Bolts

Grade 8.8 bolts to BS 4190^[43] are commonly available and recommended for all main structural connections, with the standard being 20 mm diameter.

Fully threaded bolts

Common practice in the past has been to use bolts with short thread lengths (i.e. $1.5d$) and to specify them in 5 mm increments of length. It is now recommended that fully threaded bolts (technically, termed screws) be used as the industry standard. They can be provided longer than necessary for a particular connection and can therefore dramatically reduce the range of bolt lengths specified. For example, the M20 × 60 mm long grade 8.8 fully threaded bolt has been shown to be suitable for 90% of the connections in a typical multi-storey frame.

Preloaded high strength friction grip bolts

Although the Code recognises the use of non-preloaded HSFG bolts, it is recommended that HSFG bolts only be used in the preloaded conditions.

High Strength Friction Grip bolts are usually general grade bolts to BS 4395-1^[44]. Preloaded bolts must be tightened sufficiently to provide a minimum shank tension P_o as specified in BS 4604-1^[45].

11.2.2 Connection Detailing

BS 5950-1 requirements for fastener spacing, end and edge distances are summarised in Table 11.1 and Figure 11.7 of this publication. All distances are measured from hole centres. In general, bolts are used in clearance holes that are 2 mm larger in diameter than the diameter of the bolt (for bolt diameters up to and including 24 mm). For slotted holes, the distances should be measured from the centre of its end radius or the centreline of the slot.

The minimum bolt spacing requirement ensures that the bolts are fully effective. Access for bolt tightening should also be considered.

The maximum spacing requirements are generally based on the local buckling requirements to ensure that connected elements remain flat and in contact.

Cl. 6.2.1

Table 11.1 *Fastener spacing and edge distance*

| BS 5950-1 Clause | Requirement | Distance |
|------------------|--|--|
| 6.2.1.1 | Minimum bolt spacing | $2.5d$ |
| 6.2.1.2 | Maximum spacing in unstiffened plate: <ul style="list-style-type: none"> In direction of stress Maximum spacing in any direction where the connection is exposed | $14t$ $16t \leq 200 \text{ mm}$ |
| 6.2.2.4 | Minimum edge and end distance: <ul style="list-style-type: none"> Rolled, machine flame cut or plane edge Sheared, hand flame cut or any end | $1.25D$ $1.40D$ |
| 6.2.2.5 | Maximum edge and end distance: <ul style="list-style-type: none"> Normal Exposed | $11t\varepsilon$ $40 \text{ mm} + 4t$ |

where: t is the thickness of the thinner part
 d is the nominal diameter of the bolt
 D is the hole diameter
 $\varepsilon = (275/p_y)^{0.5}$

Cl. 6.2.1.1
 Cl. 6.2.1.2
 Cl. 6.2.2.4
 Cl. 6.2.2.5

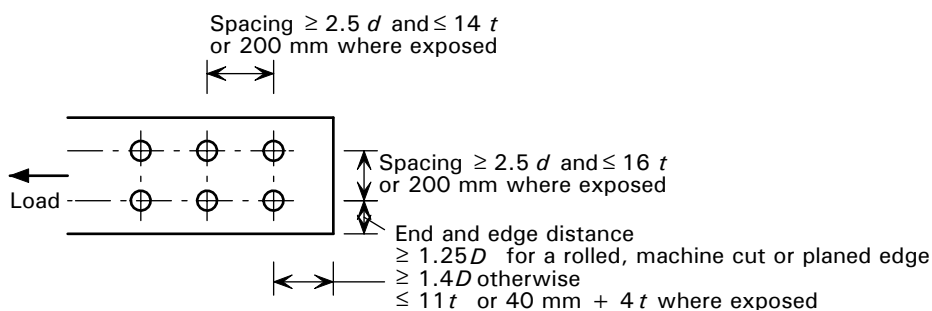


Figure 11.7 *Fastener spacing, end and edge distances*

Minimum edge and end distances are given to ensure a smooth flow of stress and to prevent edge and end splitting of the connected parts. The provision of the minimum end distance does not ensure that full bearing capacity is achieved and a reduced bearing capacity may be required for small end distances.

Maximum end distances are specified to prevent curling or lifting of the plate.

11.2.3 Design of bolted connections

Effect of bolt holes on shear capacity

Due to the beneficial effects of strain hardening, the presence of bolt holes in a plate subject to shear may be ignored, provided that $A_{v.net} \geq 0.85 A_v / K_e$ where $A_{v.net}$ is the net area of the plate and K_e is the effective net area coefficient (which equals 1.2 for S275 steel and 1.1 for S355 steel). If $A_{v.net} < 0.85 A_v / K_e$ then the shear capacity should be taken as $0.7 p_y K_e A_{v.net}$. For S275 steel this means that bolt holes can cover approximately 30% of the shear area before the shear capacity is reduced.

Cl. 6.2.3

Block shear

The block shear check ensures that the shaded areas shown in Figure 11.8 cannot fail by tearing out of the member. The failure mode is a combined shear failure and tension failure on perpendicular planes.

Cl. 6.2.4

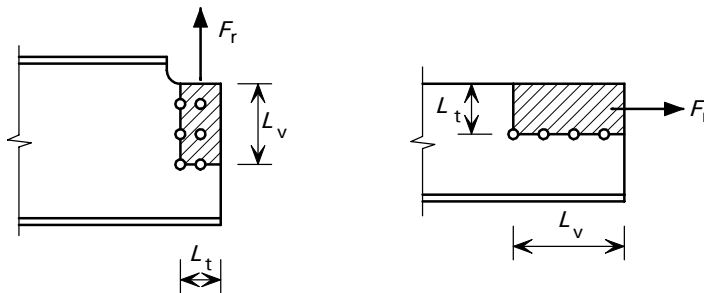


Figure 22

Figure 11.8 Examples of block shear failure

The block shear capacity is based on yielding on the gross shear plane and rupture on the net tension plane and is given as:

$$P_r = 0.6 p_y t [L_v + K_e (L_t - k D_t)]$$

where:

- D_t is the hole size (hole diameter for circular holes)
- k = 0.5 for a single line of bolts
= 2.5 for two lines of bolts
- L_t is the length of the tension face
- L_v is the length of the shear face
- t is the thickness.

Non-preloaded bolts in shear and bearing

Connections with non-preloaded bolts rely on the shear capacity of the bolts and the bearing capacity of connected plies to carry the applied shear load. The design requirements for shear and bearing are summarised in Table 11.2.

The shear area of the bolt should be taken as the tensile stress area, which will be less than the nominal shank area due to the threading of the bolt. Where it can be ensured that the threads will not occur in the shear plane then the full shank area may be used. Common practice is to assume in design that fully threaded bolts will be used and thus the shear capacity is based on the tensile stress area. The tensile stress area is given in the relevant standard and in P202^[26].

Cl. 6.3.1

The bearing capacity on the ply is governed by an acceptable deformation limit (approximately 1.5 mm at working load), rather than by ultimate failure. As bolts are usually placed in 2 mm clearance holes, this will allow a maximum of 3.5 mm movement. Where the end distance is small, there is a possibility of end splitting and therefore the capacity is reduced. The minimum requirements for end distance given in Table 11.1 should always be observed.

Table 11.2 Design requirements for non-preloaded bolts

| BS 5950-1 Clause | Check | Capacity |
|------------------|--|--|
| 6.3.2.1 | Shear capacity of bolt | $P_s = \rho_s \cdot A_s$ |
| 6.3.2.2 | Shear capacity with packing ($t_{pa} > d/3$) | $P_s = \rho_s \cdot A_s (9d)/(8d + 3 t_{pa})$ |
| 6.3.2.3 | Shear capacity of large grip ($T_g > 5d$) | $P_s = \rho_s \cdot A_s (8d)/(3d + T_g)$ |
| 6.3.2.4 | Shear capacity in kidney shaped slot | $P_s = 0.8 \rho_s \cdot A_s$ |
| 6.3.2.5 | Shear capacity of long joint ($L_j > 500$ mm) | $P_s = \rho_s \cdot A_s (5500 - L_j)/5000$ |
| 6.3.3.2 | Bearing capacity of bolt* | $P_{bb} = d \cdot t \cdot \rho_{bb}$ |
| 6.3.3.3 | Bearing capacity of ply | $P_{bs} = k_{bs} \cdot d \cdot t \cdot \rho_{bs}$ but $\leq 0.5 k_{bs} \cdot e \cdot t \cdot \rho_{bs}$ |

where:

ρ_s is the shear strength of the bolt

ρ_{bb} is the bearing strength of the bolt

ρ_{bs} is the bearing strength of the connected ply
= 460N/mm² for S275
= 550N/mm² for S355

e is the end distance

A_s is the shear area

L_j is the length of the joint

t_{pa} is the thickness of the pack

T_g is the thickness of the grip

k_{bs} = 1.0 for bolts in standard holes
= 0.7 for bolts in oversized and short slotted holes
= 0.5 for bolts in long slotted and kidney shaped holes

| | Grade 4.6 N/mm ² | Grade 8.8 N/mm ² |
|-------------|--------------------------------|--------------------------------|
| ρ_s | 160 | 375 |
| ρ_{bb} | 460 | 1000 |

* Bearing capacity of the bolt will never be critical unless a 'very low' grade of bolt is used with a 'very high' grade of ply.

For long joints (see Figure 11.9), there is an unequal distribution of force within the bolts. To allow for this the shear capacity of each of the bolts is reduced. This requirement applies to situations where the load is transferred directly (e.g. a flange splice). It does not apply to situations where the connection is transferring shear gradually, such as in a web to flange connection in a plate girder or in an end plate connection.

For large grip lengths (see Figure 11.10), the shear capacity is reduced to allow for the bending moment in the bolt, in addition to the shear.

For connections with thick packing, the shear capacity is also reduced to allow for possible bolt bending. It is recommended that the total thickness of packing should not exceed $4d/3$ and that the number of loose packs should not exceed four.

Table 30
Table 31

Table 32

Cl. 6.3.2.5

Cl. 6.3.2.3

Cl. 6.3.2.2

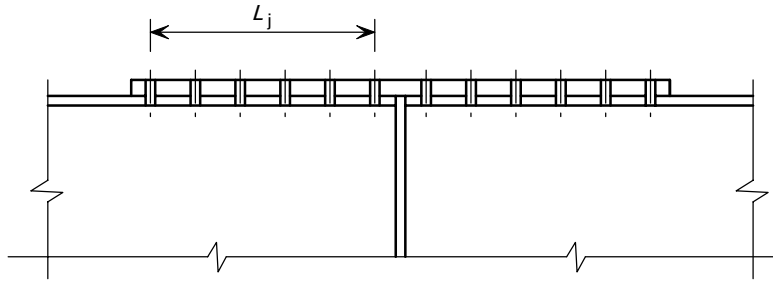


Figure 11.9 Lap length of a splice - an example of a 'long joint'

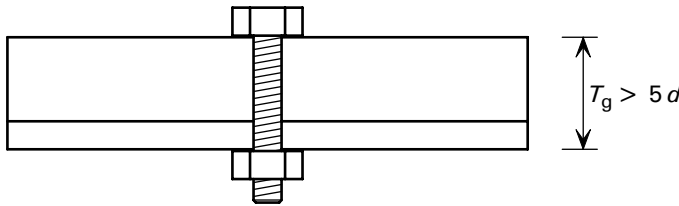


Figure 11.10 Large grip length

Cl. 6.3.2.3

Non-preloaded bolts subject to tension

BS 5950-1 recommends that where the connection is subjected to tension, either directly or by bending, prying action should be taken into account. The T-stub connection shown in Figure 11.11 is subject to a tensile force $2F_t$. The bolts will be subjected to a tensile force equal to half the applied load plus a prying force, which will vary depending on the details and stiffness of the plates. The prying forces Q can be high, but calculation methods vary and produce a wide variation of results. BS 5950-1 allows two approaches; the simple method and the more exact method as explained below.

Cl. 6.3.4.1

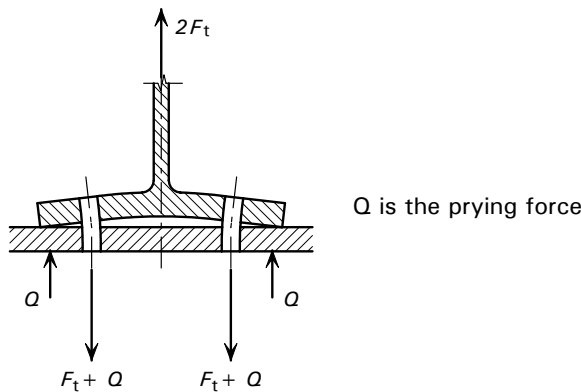


Figure 25

Figure 11.11 T stub model for prying action

Simple method

In the simple method, the prying force is neglected and the bolt force is simply taken as equal to F_t . However, in this case, the full tension capacity of the bolts cannot be used and, instead, the connection must be designed so that F_t does not exceed the nominal tension capacity of the bolt given by:

Cl. 6.3.4.2

$$P_{nom} = 0.8 p_t A_t$$

where:

- A_t is the tensile stress area of the bolt
 p_t is the tension strength of the bolt
 = 240 N/mm² for grade 4.6 bolts
 = 560 N/mm² for grade 8.8 bolts.

There are two conditions on the use of the simple method. Firstly, this method should only be used if the cross-centre spacing of the bolt holes, s , does not exceed 55% of the width of the flange or end-plate, as shown in Figure 11.12.

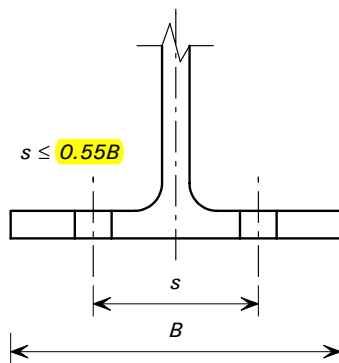


Figure 11.12 Maximum cross-centres of bolts for the simple method

This is to ensure that the prying force is kept within the limits allowed for by the use of $0.8p_t$ in the calculation of the nominal tension capacity. A cross-centre spacing greater than $0.55B$ may result in a prying force in excess of that allowed for in the simplified method, making this method unsafe. In such circumstances, the prying forces must be taken into account explicitly by using the more exact method.

Secondly, where the connected part is designed assuming double curvature bending, the moment capacity of the connected part per unit width should be based on the elastic capacity rather than the plastic capacity (i.e. the moment capacity per unit width should be taken as $p_y t_p^2 / 6$, where t_p is the thickness of the connected part and p_y is its design strength).

More exact method

For the more exact method prying action is calculated explicitly and taken into account. The bolt tension capacity may be obtained from:

$$P_t = p_t A_t$$

Bolts designed using the more exact method must be designed to resist their proportion of applied force and the prying force acting on the connection.

Non-preloaded bolts subject to combined shear and tension

For the simple method, the following interaction expression should be satisfied:

$$\frac{F_s}{P_s} + \frac{F_t}{P_{\text{nom}}} \leq 1.4$$



Cl. 6.3.4.3

Cl. 6.3.4.4

where:

F_s is the applied shear force per bolt

F_t is the applied tensile force per bolt

P_s is the bolt shear capacity

P_{nom} is the nominal tension capacity of the bolt.

For the more exact method, the following interaction expression should be satisfied:

$$\frac{F_s}{P_s} + \frac{F_{\text{tot}}}{P_t} \leq 1.4$$

where:

F_{tot} is the applied tensile force per bolt including prying forces

All other terms are as described above.

Preloaded bolts

Preloaded bolts may be designed as non-slip in service or non-slip at ultimate load (factored loads). It is normal to design the connection to be non-slip in service (i.e. at working load), but allow it to slip before ultimate load. After slip it is therefore necessary to check the bearing and shear capacities at ultimate load. The requirements for preloaded bolts are summarised in Table 11.3 of this publication.

Where the bolts are preloaded the connection is normally designed not to slip into bearing at working load and therefore relies on the friction between the interfaces or faying surfaces. In situations where an HSFG bolt is not pre-loaded the bolt may be designed as an ordinary bearing bolt.

Cl. 6.4.1

Table 11.3 Design requirements for preloaded bolts

| BS 5950-1 Clause | Check | Capacity |
|----------------------|------------------------------|--|
| Non-slip in service: | | |
| 6.4.2 | • Slip resistance | $P_{sL} = 1.1 K_s \mu P_o$ and $P_{sL} \leq P_{bg}$ but $P_{sL} \leq P_s^*$ |
| 6.4.4 | • Shear capacity at ULS | P_s |
| 6.4.4 | • Bearing capacity at ULS | $P_{bg} = 1.5 d t_p \rho_{bs}$ but $\leq 0.5 e t_p \rho_{bs}$ |
| 6.4.5 | • Combined shear and tension | $(F_s/P_{sL}) + (F_{tot}/1.1 P_o) \leq 1.0$ and $F_{tot} \leq A_t p_t$ |
| Non-slip at ULS | | |
| 6.4.2 | • Slip resistance | $P_{sL} = 0.9 K_s \mu P_o$ |
| 6.4.5 | • Combined shear and tension | $(F_s/P_{sL}) + (F_{tot}/0.9 P_o) \leq 1.0$ and $F_{tot} \leq A_t p_t$ |

where:

- P_o is the minimum bolt preload (i.e. minimum shank tension) (BS 4604^[45])
- K_s is 1.0 for clearance holes, 0.85 for short slotted holes, oversize holes and long slotted holes loaded perpendicular to the slot and 0.7 for long slotted holes loaded parallel to the slot
- μ is the slip factor, obtained from Table 35 or BS 5950-1 (ranges from 0.5 to 0.2) or from tests as specified in BS 4604^[45].
- ρ_{bs} is the bearing strength of the connected parts, 460 N/mm² for S275 steel and 550 N/mm² for S355.
- e is the end distance
- F_s is the applied shear
- F_{tot} is the total applied tension in the bolt including the prying force

* The restrictions for packing, large grip lengths and long joints need not be applied to preloaded bolts.

Cl. 6.4.2

Cl. 6.4.4

Cl. 6.4.5

11.3 Welded connections

11.3.1 Weld Types

There are two general types of weld that are used in structural steelwork; fillet welds and butt welds. Figure 11.13 shows a butt weld and Figure 11.14 shows a fillet weld, with annotation of their components. Fillet welds are generally more common because end preparation of the elements to be welded is not required. The design of fillet welds and butt welds is covered in the following Sections.

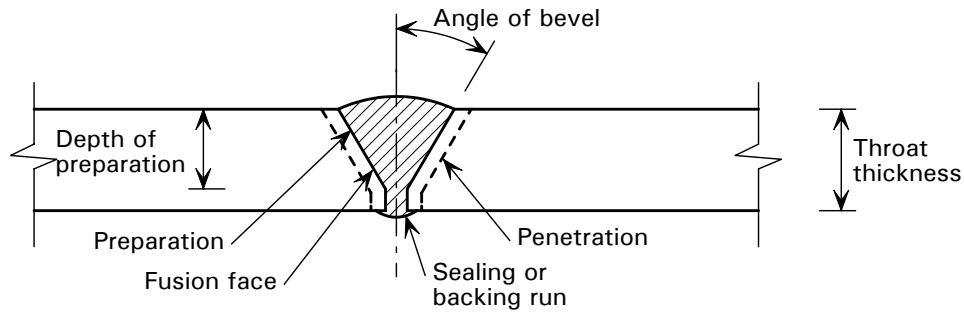


Figure 11.13 Typical butt weld

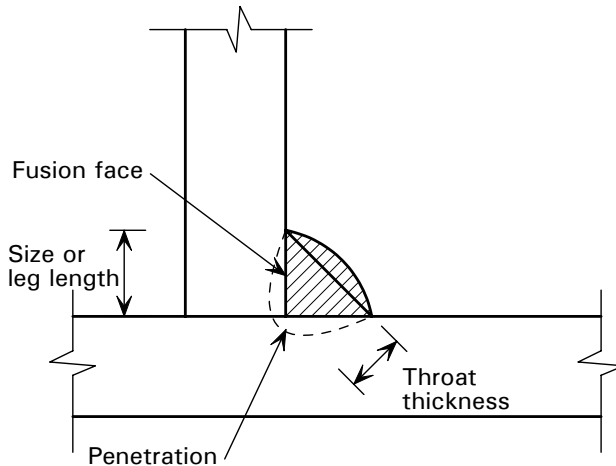


Figure 11.14 Typical fillet weld

11.3.2 Details of fillet welds

BS 5950-1 gives a number of requirements for the detailing of fillet welds that are illustrated in Figure 11.15. Cl. 6.7.2

1. Where possible, fillet welds terminating at the end or side of parts should returned continuously around the corners for a distance of not less than twice the leg length s . This ensures that the defect prone regions at the stop and start positions are not included in the weld design. Cl. 6.7.2.2
2. In lap joints, the minimum lap should not be less than four times the thinner plate joined. Cl. 6.7.2.3
3. Where the end of an element is connected only by longitudinal fillet welds the length of each weld should not be less than the transverse spacing. Cl. 6.7.2.4
4. Single fillet welds should not be subject to bending about the longitudinal axis of the weld that would open the root of the weld. Cl. 6.7.2.5
5. Intermittent fillet welds should not be used in situations that could lead to corrosion. Cl. 6.7.2.1
6. The longitudinal spacing between effective lengths of weld should not exceed 300 mm or $16t$ for compression elements and $24t$ for tension elements. Where t is the thickness of the thinner part joined. Cl. 6.7.2.6
7. Back-to-back struts and ties should have spacings of welds in accordance with Cl. 4.7.13 and Cl. 4.6.3 respectively. Cl. 6.7.2.6

The limitations in 6. and 7. ensure that the parts are held sufficiently close to allow the paint film to bridge the gap and prevent buckling of compression members.

The intermittent fillet weld spacing limits are not intended to apply to shelf angles where, provided corrosion is not an issue, the gap can be 300 mm.

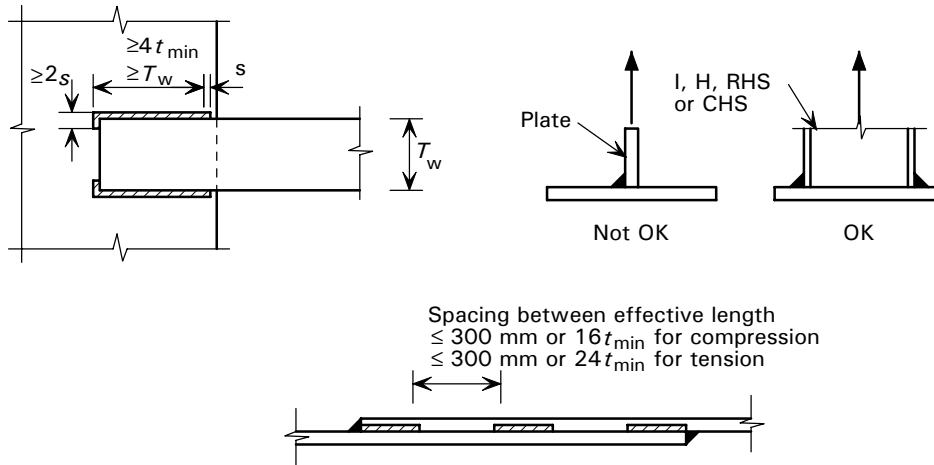


Figure 11.15 Requirements for fillet welds

11.3.3 Details of welds in hollow sections

The design of welded hollow section connections is not covered in detail in BS 5950-1. For detailed guidance, reference should be made to CIDECT design guides^{[46][47]} or Corus Tubes literature^{[48][49]}.

However, the following general requirements are given in BS 5950-1:

- (a) A weld connecting two structural hollow sections end to end should be a full penetration butt weld Cl. 6.7.3
- (a) A weld connecting two structural hollow sections end to end should be a full penetration butt weld Cl. 6.7.3.1
- (b) A weld connecting the end of one hollow section to the surface of another should be continuous and may be a butt weld throughout, a fillet weld throughout, or a fillet weld in one part with a butt weld in another, with a continuous transition from one to the other. Cl. 6.7.3.2
- (c) Joints at which two or more SHS connect should be overlap joints with sufficient overlap to transfer the forces between the members or gap joints with sufficient clearance between welds connecting each member. This clearance may result in eccentricity at the intersections that should be considered in the design of the member and connection. Cl. 6.7.3.3

The designer should be aware that the strength of a connection between hollow sections depends not only on the strength of the weld but also on the size of the members joined. Lack of consideration of this by the designer of the members in a welded lattice truss can result in expensive and unattractive stiffening by the fabricator when the connections are designed.

11.3.4 Design of fillet welds

The code gives two methods for checking fillet welds:

- The simple method Cl. 6.8.7.2
- The directional method Cl. 6.8.7.3

The second method recognises the fact that the transverse capacity of the fillet weld is greater than the longitudinal shear capacity of the weld.

The design strength of fillet welds is obtained from Table 37 of BS 5950-1, reproduced here in part as Table 11.4.

Table 11.4 Design strength of fillet welds p_w

| Steel grade | Electrode Classification | | |
|-------------|--------------------------|-------------------|-------------------|
| | 35 | 42 | 50 |
| | N/mm ² | N/mm ² | N/mm ² |
| S275 | 220 | 220 ^a | 220 ^a |
| S355 | 220 ^b | 250 | 250 ^a |
| S460 | 220 ^b | 250 ^b | 280 |

Note: **Bold** type signifies recommended electrode class for the steel grade

^a Over-matching electrodes, ^b Under-matching electrodes

Table 37

Fillet welds are usually specified by the leg length s , e.g. a 6 mm fillet weld. The actual capacity of the weld is based on the effective throat size a . The effective throat size should be taken as the perpendicular distance from the root of the weld to a straight line joining the fusion faces that just lies within the cross-section of the weld, see Figure 11.16. The value of a to be used in calculating weld capacity should be the smaller of a shown in Figure 11.16 and $0.7s$.

Cl. 6.8.3
Cl. 6.8.7.1

The effective length of the weld run should be taken as equal to the overall length less one leg length s where the weld does not return around a corner. This is to allow for poor welding at the stop and start positions of the weld. The effective length of weld should be at least 40 mm but not less than $4s$.

Cl. 6.8.2

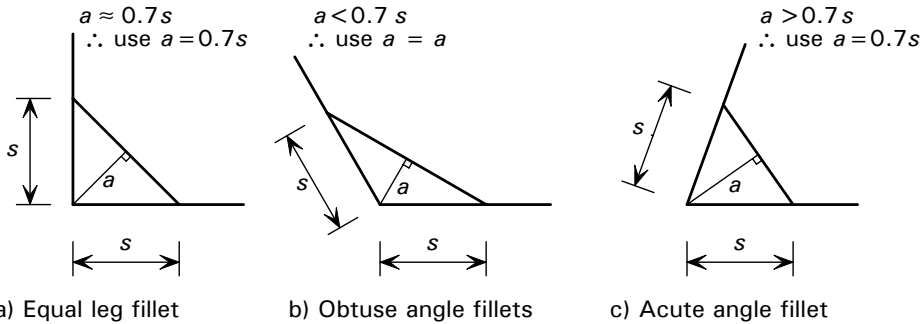


Figure 11.16 Fillet welds - leg length s and throat thickness a

Simple method

The vector sum of the applied stresses acting on the weld should not exceed the weld design strength p_w at any point along the weld. The applied stresses should be calculated on the weld throat thickness a .

Cl. 6.8.7.2

Directional method

The forces acting on the weld should be resolved into longitudinal and transverse forces. The longitudinal force (F_L) acts parallel to the weld and the transverse force (F_T) acts perpendicular to the weld, as shown in Figure 11.17.

Cl. 6.8.7.3

The longitudinal shear capacity of the weld per unit length is given by:

$$P_L = p_w a$$

The transverse capacity of the weld per unit length is given by:

$$P_T = K p_w a$$

where:

p_w is the weld design strength

a is the weld throat thickness

K is a coefficient to account for the angle θ between the force and the throat of the weld

$$K = 1.25 \sqrt{\frac{1.5}{1 + \cos^2 \theta}}$$

$K = 1.25$ for case (b) of Figure 11.17)

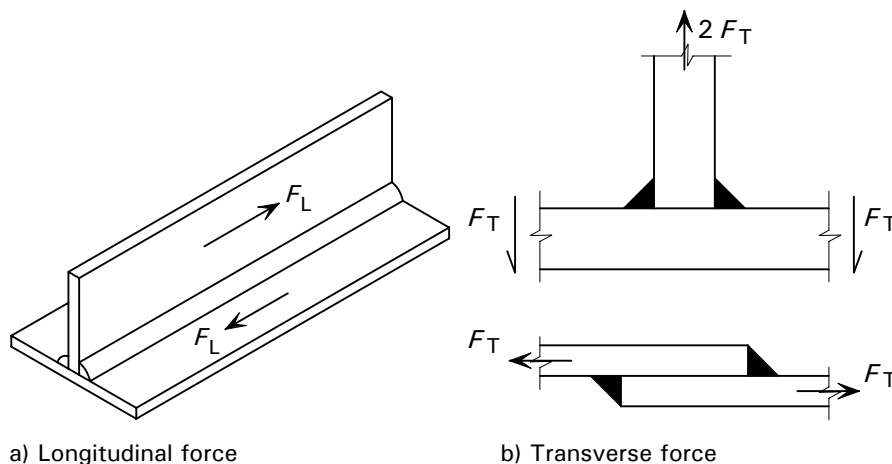


Figure 31

Figure 11.17 Fillet weld design – Directional method

To take account of the interaction between longitudinal and transverse forces, the following relationships should be satisfied throughout the length of the weld:

$$\left(\frac{F_L}{P_L}\right)^2 + \left(\frac{F_T}{P_T}\right)^2 \leq 1$$

where:

F_L is the longitudinal force acting on the weld

F_T is the transverse force acting on the weld

P_L and P_T are as defined above.

11.3.5 Design of butt welds

The design strength of butt welds should be taken as equal to that of the parent metal, provided that suitable electrodes are used. If the parent metals are of different grades, then the design strength of the weld should be assumed to be equal to the lower grade parent metal. However, the electrodes used must be those suitable for the higher grade parent metal.

Cl. 6.9.1

The throat thickness of a partial penetration butt weld should be taken as equal to the minimum depth of penetration. Generally, the depth of penetration will be:

- For a “V” butt joint, 2 mm less than the depth of weld preparation
- For a “U” butt joint, equal to the depth of weld preparation.

A design consultant should only specify the required weld throat size. A fabricator’s designer may wish to specify the weld preparation. However, a welding engineer who knows that the required throat size can be achieved with less preparation is free to use less preparation.

The minimum throat size of a longitudinal partial penetration butt weld (e.g. at the corner of a box girder, as shown in Figure 11.18) should be $2\sqrt{t}$, where t is the thickness (in mm) of the thinner part joined.

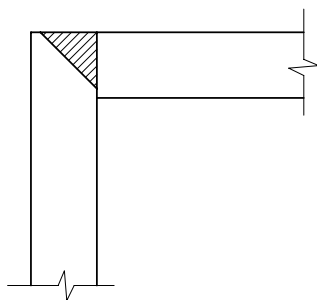


Figure 11.18 *Corner joint with partial penetration butt weld*

11.4 Baseplates

11.4.1 Effective area method

The actual distribution of pressure beneath a baseplate is extremely complex. BS 5950-1 assumes a uniform distribution of pressure beneath an effective area of the baseplate (as shown in Figure 11.19). The bearing pressure is limited to the nominal bearing strength equal to $0.6f_{cu}$, where f_{cu} is the characteristic cube strength of the foundation or the bedding material at 28 days.

Cl. 4.13.1

The effective area of a baseplate subject to compression is the area required to resist the axial load F_c and is given by:

$$\text{Effective area} = F_c / (0.6f_{cu})$$

where:

- F_c is the applied axial compression
- f_{cu} is the characteristic cube strength of the concrete or the bedding material, whichever is smaller.

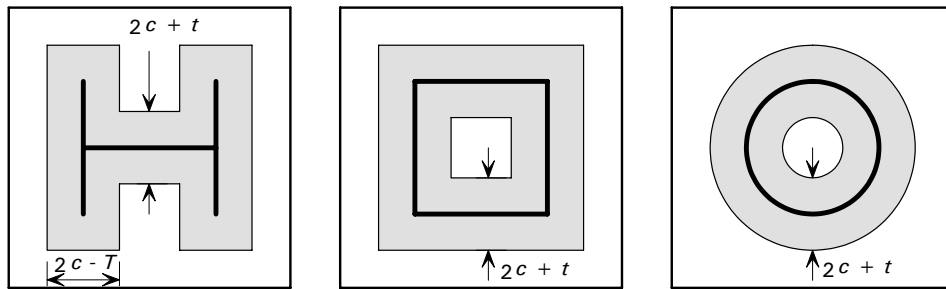


Figure 11.19 Effective area of a baseplate

11.4.2 Baseplate thickness

Provided that axial load is applied concentrically the minimum baseplate thickness is given by: Cl. 4.13.2.2

$$t_p = c[3w/p_{yp}]^{0.5}$$

where:

- c is the effective area outstand from the edge of the column section
- w is the pressure under the baseplate based on an assumed uniform distribution of pressure under the effective area ($0.6 f_{cu}$)
- p_{yp} is the design strength of the baseplate

If the load is not applied concentrically, the moments in the baseplate due to the eccentricity should not exceed the elastic moment capacity of the plate.

If moments are applied to the baseplate via the column, the moment in the baseplate should not exceed the plastic moment capacity of the baseplate. Cl. 4.13.2.3

Detailed design guidance on baseplates is provided in P212^[37], P207^[38] and AD 252^[50].

11.4.3 Connections to the baseplate

Compressive forces may be transmitted in direct bearing provided that surfaces met the requirements of flatness for full bearing contact as given in BS 5950-2^[1] Clause 7.2.3. Otherwise, the welds or fasteners must be designed to transmit all the forces and moments. Cl. 4.13.3

11.4.4 Holding down bolts

Holding down bolts should be designed for the effects of factored loading. Where they are required to resist tension they should be properly anchored into the foundation by a washer plate or other load distributing member embedded in the concrete as shown in Figure 11.20. Expanding and resin grouted anchors can be used, provided that it can be demonstrated that the required performance can be achieved.

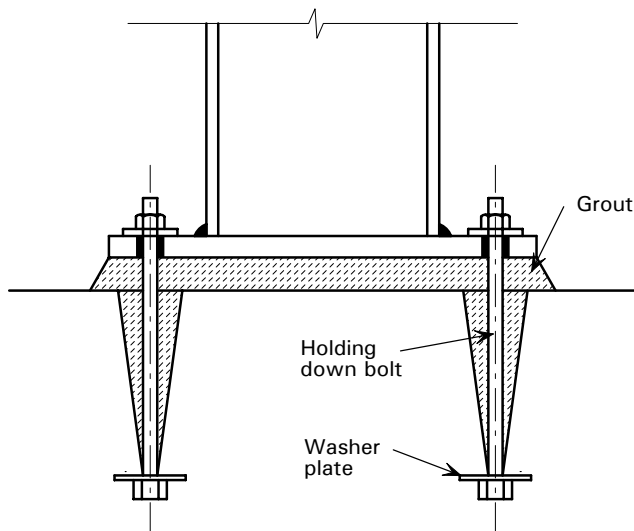


Figure 11.20 *Holding down bolts and concrete base*

Rag bolts or indented foundation bolts that are grouted into pockets cast into a concrete foundation should not be used to resist tension. Cl. 6.6

The tension capacity of a holding down bolt should be taken as: Cl. 4.13.2.4

$$P_t = 0.8 p_t A_t$$

where:

A_t is the tensile stress area of the bolt

p_t is the tension strength of the bolt Cl. 6.6

11.4.5 Shear transfer

The connection must also be capable of resisting any shear forces present. Shear resistance can be provided by:

- Frictional resistance at the interface
- Bearing between the shafts of the holding down bolts and the concrete surrounding them
- Direct shear resistance, by setting the baseplate in a shallow pocket that is filled with concrete or by providing a shear key welded to the underside of the base plate.

11.5 Summary of design procedure

Below is a general design procedure that can be applied to any type of connection.

1. Select a suitable design model
2. Following the load path, check the capacity of each element of the connection with the forces and moments acting on it.

Note: The design checks must be consistent with the adopted design model.

12 PLASTIC DESIGN OF PORTAL FRAMES

12.1 Introduction

This section covers a number of features of plastic design of portal frames to BS 5950-1. The frame is analysed plastically allowing the formation of plastic hinges, which can rotate to allow the redistribution of bending moments. The frame is then designed in a similar way to a frame analysed elastically. However, there are some special clauses in BS 5950-1 for design based on plastic analysis, which will be covered in this section.

Cl. 5.5

12.2 Plastic analysis

Simple plastic analysis, rather than elastic analysis, is commonly used for the design of portal frames as it results in relatively lightweight frames. The analysis is usually carried out by the use of specialist software, or by hand, using the basic principles of simple plastic theory. A manual method, which may be used to carry out an initial analysis of the frame, is given in Appendix A of this publication.

Plastic analysis assumes that plastic hinges occur at points in the frame where the value of the applied moment is equal to the plastic moment capacity of the member provided. Failure is deemed to have taken place when sufficient hinges have formed to create a mechanism. Having selected suitable member sizes, from strength considerations, the ultimate plastic collapse load of the frame is calculated. The ultimate load will generally be in the order of 5 to 10% greater than the design load due to the incremental range of member sizes. This method of design has been documented in many publications, one of the most useful of which is *Plastic design* by Davies and Brown^[51]. Plastic design methods result in relatively slender frames and checking frame stability is a basic requirement of the method. In addition, it is essential that local buckling and lateral distortion are also checked, because of the large strains at the hinge positions.

In order to prevent local buckling it is essential that Class 1 plastic sections are selected, in accordance with Table 11 of BS 5950-1, at locations where hinges are required to rotate. Stability of the frame and individual members should be checked according to Section 5 of the code.

12.2.1 Code requirements for plastic analysis

The Code recommends that plastic analysis should only be used for structures or elements that satisfy certain requirements, summarised below:

Cl. 5.2.3.1

- The loading should be predominately static i.e. fatigue is not a design criterion.
- The steel should be grade S275, S355 or S460. If other steel grades are to be used their properties should satisfy the requirements given in the Code.

Cl. 5.2.3.2

Cl. 5.2.3.3

- Special fabrication requirements are given for the tension flange within a distance D either side of the location of a plastic hinge. (D is the depth of the member). Cl. 5.2.3.4
- Members with plastic hinges should be Class 1 plastic at the plastic hinge location. Cross-sections should also be symmetrical about the axis perpendicular to the axis of plastic hinge rotation. Cl. 5.2.3.5
- At the plastic hinge location and either side of the plastic hinge until the moment in the member is less than 80% of the reduced moment capacity of the member, the net area of the cross-section (i.e. after deducting bolt holes) should be at least equal to the gross cross-section area divided by K_e . (K_e is 1.2 for S275 and 1.1 for S355). Cl. 5.2.3.6
- For members with plastic hinges where the shear force is greater than 10% of the section shear capacity within a distance of $D/2$ of the plastic hinge, web stiffeners should be applied. Cl. 5.2.3.7
- Haunches should be designed (i.e. proportioned) to prevent plastic hinges forming within their length. Cl. 5.2.3.8

Full descriptions of these recommendations are given in BS 5950-1.

12.3 Frame stability

With the use of lighter frames, various aspects of stability are becoming more prominent in the design procedures. In-plane and out-of-plane stability of both the frame as a whole and the individual members must be considered. This Section covers the various aspects that should be addressed with regard to portal frames.

12.3.1 In-plane frame stability

Having determined the size of the members based on strength considerations it is necessary to check the in-plane stability of the frame and make any allowance for the second-order ($P\Delta$) effects. SCI publication P292^[52] covers the in-plane stability of portal frames in considerable depth.

The basic requirement is that:

$$\lambda_p \geq \lambda_r$$

where:

λ_p is the plastic collapse load factor i.e. the collapse load divided by the design load

λ_r is a the required plastic collapse load factor to allow for $P\Delta$ effects

If the $P\Delta$ effects are insignificant then λ_r will equal unity.

Three methods of determining the value of λ_r are given:

- (a) The sway check method (also check snap through stability for ≥ 3 bays)
- (b) The amplified moments method
- (c) Second-order analysis

Cl. 5.5.4

Cl. 5.5.3

Cl. 5.5.4.1

Sway check method

The sway check method may be used where the following conditions are satisfied in each bay of the frame under consideration (see Figure 12.1):

- (a) $L \leq 5h$
- (b) $h_r \leq 0.25L$
- (c) If the rafter is asymmetric, $(h_r / s_a)^2 + (h_r / s_b)^2 \leq 0.5$

Cl.
5.5.4.2.1

Figure 18

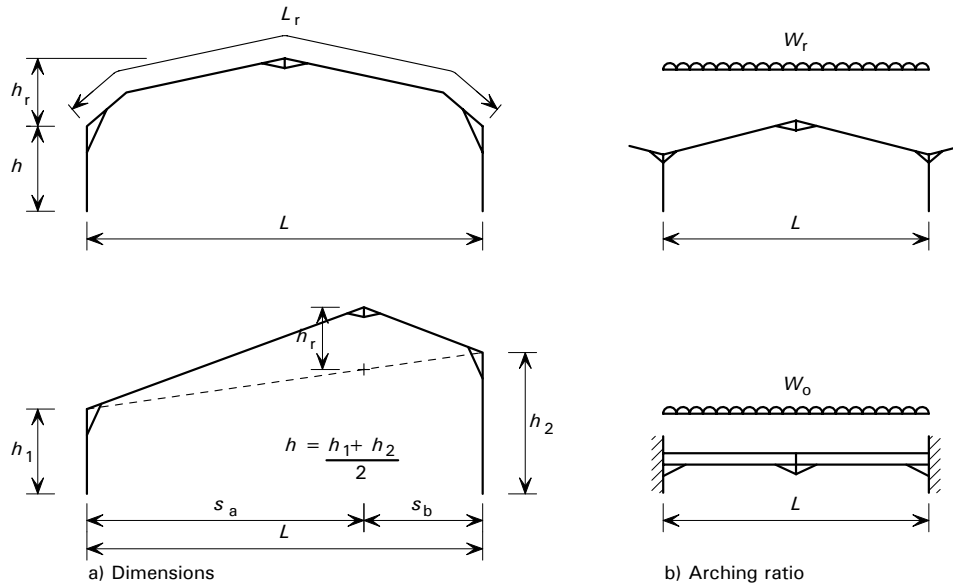


Figure 12.1 Dimensions of frame

Where these conditions are satisfied linear elastic analysis should be used to determine the deflection at the top of the columns when the frame is subjected to a notional lateral force generally applied at the top of the columns.

The notional force should be taken as equal to 0.5% of the vertical reaction at the base of the columns. Where a significant proportion of the load is applied in the length of the column (e.g. from a crane gantry) the notional force derived from these loads may be applied at the same level. Figure 12.2 shows an example of how the notional horizontal forces are applied.

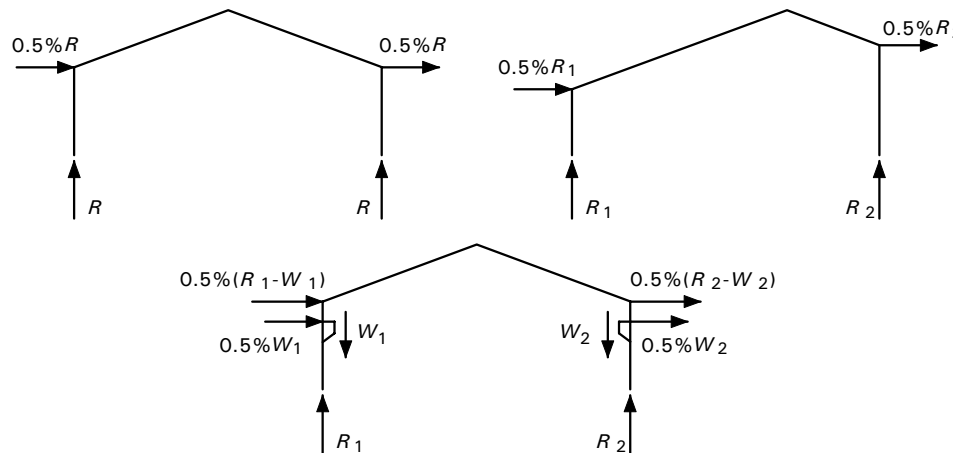


Figure 12.2 Application of notional horizontal forces

Sway check method for load cases involving only gravity loads

For gravity loads (generally 1.4 Dead load + 1.6 Imposed load) the deflection due to the notional force should be determined without any allowance for the stiffening effect of the cladding.

If $\delta_1 \leq h_i/1000$ then $\lambda_r = 1.0$, i.e. the $P\Delta$ effects are insignificant and can be ignored hence the section sizes chosen will provide a stable frame.

where:

δ_1 is the horizontal deflection at the eaves.

As an alternative and more conservative method for frames not subjected to loads from valley beams, crane gantries or point loads, the condition $\delta_1 \leq h_i/1000$ may be assumed to be satisfied if for each bay the following expression is satisfied.

$$\frac{L_b}{D} \leq \frac{44L}{\Omega h} \left(\frac{\rho}{4 + \rho L_r / L} \right) \left(\frac{275}{p_{yr}} \right) \quad \text{then} \quad \lambda_r = 1.0$$

where:

$$L_b \quad \text{is the effective span of the bay} \quad = L - \left(\frac{2D_h}{D_s + D_h} \right) L_h$$

$$\rho = \left(\frac{2I_c}{I_r} \right) \left(\frac{L}{h} \right) \quad \text{for a single bay frame}$$

$$\rho = \left(\frac{I_c}{I_r} \right) \left(\frac{L}{h} \right) \quad \text{for a multi bay frame}$$

Ω is the arching ratio = W_r / W_0

D , D_h and D_s see Figure 12.3

I_c is the in-plane second moment of area of the columns (taken as zero if the column is not rigidly fixed to the rafter, or if the rafter is supported on a valley beam)

I_r is the in-plane second moment of area of the rafter

L_h is the horizontal length of the haunch

p_{yr} is the design strength of the rafters in N/mm^2

W_r is the total factored vertical load on the rafters of the bay

W_0 is the maximum load (assuming plastic analysis) that can be placed on the rafter treated as a fixed ended beam of span L (i.e. $W_0 = 16 S_x p_y / L$) see Figure 12.1.

All other terms are as defined in Figure 12.1.

Cl.
5.5.4.2.2

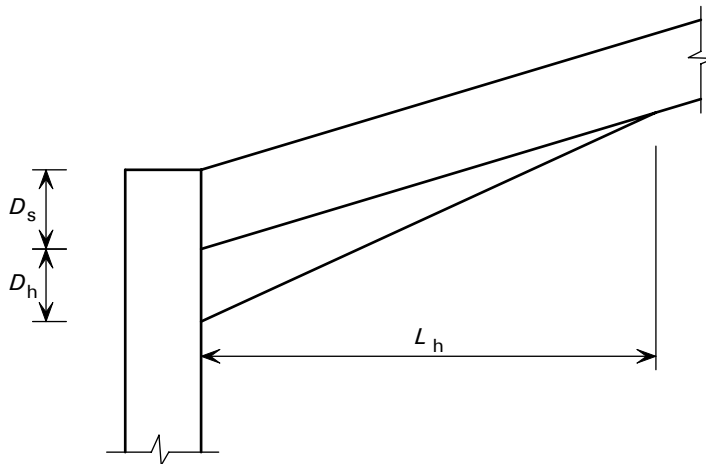


Figure 12.3 Dimensions of a haunch

Sway check method for load cases involving horizontal loads

The $P\Delta$ effects can never be neglected under horizontal loading and must always be taken into account when designing portal frames for load combinations 2 and 3.

For load cases involving wind loads or other horizontal loads, allowance may be made for the stiffening effect of the cladding in calculating the deflection due to notional horizontal forces. The real horizontal loads should not be combined with the notional horizontal forces.

C1.
5.5.4.2.3

The value of λ_r for load cases involving horizontal loads may be determined from the following simple expressions, provided that the frame is stable under gravity loading (i.e. the $\delta_i \leq h_i/1000$ criteria or the formula is satisfied for gravity loading).

$$\lambda_r = \frac{\lambda_{sc}}{(\lambda_{sc} - 1)}$$

In which λ_{sc} is an approximation to the elastic critical load factor for the sway mode and is the smallest value, considering each column.

$$\lambda_{sc} = \frac{h_i}{200 \delta_i}$$

where:

δ_i is the horizontal deflection at the top of the column due to notional horizontal force for the relevant load case.

Provided that the frame is not subjected to loads from valley beams, crane gantries or other concentrated loads λ_{sc} may alternatively be calculated approximately from:

$$\lambda_{sc} = \frac{220 DL}{\Omega h L_b} \left(\frac{\rho}{4 + \rho L_r / L} \right) \left(\frac{275}{p_{yr}} \right)$$

All terms are as defined above.

If $\lambda_{sc} < 5.0$ then second-order analysis should be used to take account of the $P\Delta$ effects.

Snap-through stability

Due to the effects of continuity in multi-bay frames, there is a risk of rafters being reduced in size in internal bays to the extent that the apex “snaps through” to hang below the eaves level. This mode of failure has been identified and a design restriction applied when a frame consists of three or more bays. Therefore, snap-through stability need only be considered for internal bays of multi-span frames.

The procedure is to use a formula (given below) similar to that used for sway stability. If the arching ratio Ω is less than unity no limit need be placed on L_b/D . For all other cases the following formula should be satisfied:

$$\frac{L_b}{D} \leq \frac{22(4 + L/h)}{4(\Omega - 1)} \left(1 + \frac{I_c}{I_r} \right) \left(\frac{275}{p_{yr}} \right) \tan 2\theta$$

where:

θ is the slope of the rafters for a symmetrical frame

$\theta = \tan^{-1}(2h_r/L)$ for other roof shapes

All other terms are as defined above.

Alternative methods

Where the frame does not meet the requirements of the sway-check method there are two alternative means of allowing for the $P\Delta$ effects, known as the “amplified moments method” and “second-order analysis”.

The amplified moments method

This method, which is applicable to all portal frames, requires the calculation of λ_r , which relies on the ability to calculate the value of the elastic critical load factor λ_{cr} for the relevant load case. The elastic critical load factor is the elastic critical load/design load and can be calculated using a computer buckling analysis. Alternative methods of calculating the value of λ_{cr} are given in the SCI publication *In-plane stability of portal frames to BS 5950-1:2000*^[52].

The required load factor λ_r is given by:

If $\lambda_{cr} \geq 10$ then $\lambda_r = 1.0$ i.e. the frame is stable

If $10 > \lambda_{cr} \geq 4.6$ then $\lambda_r = \frac{0.9 \lambda_{cr}}{(\lambda_{cr} - 1)}$

If $\lambda_{cr} < 4.6$ then the frame is very flexible and the amplified moments method must not be used. Second-order analysis must be used to take account of the $P\Delta$ effects.

Cl. 5.5.4.3

Cl. 5.5.4.3

Cl. 5.5.4.4

Cl. 5.5.4.4

Second-order analysis

This method of allowing for $P\Delta$ effects may be applied to all portal frames, or if the above methods are not appropriate. Second-order analysis is the term used to describe analysis methods in which the effects of increasing deflection under increasing load are considered explicitly in the solution method. Second-order analysis will normally be more accurate than first-order analysis with magnification factors. It is recommended that second-order analysis is performed by computer software, but where such software is not available hand calculations are possible and guidance is given in SCI publication P292^[52].

Cl. 5.5.4.5

Reliable software programs that will carry out second-order analysis on portal frames are commercially available. When second-order analysis is used, λ_r should be taken as 1.0. Further guidance is provided in reference 52.

Tied portals

Tied portals should be treated with extreme caution to ensure stability of the slender rafters that will be subject to very high axial compression. The code recommends that the in-plane stability of tied portals should be checked using elastic or elastic-plastic second-order analysis with λ_r taken as 1.0.

Cl. 5.5.4.6

12.3.2 Out-of-plane frame stability

The out-of-plane stability of the frame should be ensured by making the frame effectively non-sway out-of-plane. This will usually imply bracing of some sort, although the use of very stiff portal frame action is not uncommon.

Cl. 5.5.1
Cl. 2.4.2.5

Guidance on the classification of frames as either non-sway or sway-sensitive is given in Section 1.6.3.

The out-of-plane stability of frame members is covered in Section 12.5.2.

12.4 Deflections

It is important to check that a structure that possesses sufficient strength will perform satisfactorily at service loads.

Portal frames are generally designed on the basis of strength first and then checked for deflections at serviceability loads according to some criteria. Deflection limits can govern the design of portal frames and therefore it is important that any limits are realistic. Generally, codes do not give specific recommended limits for portal frame deflections because this issue has not been adequately researched. Therefore, the responsibility for selecting deflection limits rests with the designer and in order to assist the designer some guidance is provided in SCI publication P070^[53] and Advisory Desk note AD090^[54].

12.5 Member Stability

12.5.1 In-plane member stability

The in-plane stability of the members of a plastically designed portal frame should be established by checking the in-plane stability of the actual frame (as described in Section 12.3.1). The only exceptions to this rule are the members of a tied portal, which must be checked individually for in-plane stability, and the internal columns of a multi-bay portal frame, which should also be checked individually for in-plane stability.

Cl. 5.2.3.1

12.5.2 Out-of-plane member stability

The out-of-plane stability of all frame members should be ensured by the provision of appropriate lateral and torsional restraints, under all load cases.

Cl. 5.2.3.1

If the rigid-plastic load factor λ_p of the frame is more than the required load factor λ_r for the load case under consideration, the resistance of the members to out-of-plane buckling can be checked by using moments and forces corresponding to λ_r , rather than λ_p .

Cl. 5.3.1

Torsional restraints

A torsional restraint is a restraint that prevents the section twisting. Torsional restraint can be achieved by providing lateral restraint to both flanges of a section. The use of a “fly” brace as shown in Figure 12.4 is common, although other methods can be used.

Cl. 5.5.5

At the point of contraflexure in a portal frame rafter, the section may be considered to be torsionally restrained by assuming a virtual lateral restraint to the bottom flange if the purlins and their connection to the top flange are capable of providing torsional restraint to the top flange of the rafter.

Torsional restraint of the top flange of the rafter may be assumed to exist if all the following conditions are satisfied:

Cl. 5.5.5

- (a) The rafter is an I-section with $D/B \geq 1.2$, where D is the depth and B is the flange width
- (b) For haunched rafters, D_h is not greater than $2D_s$
- (c) Every length of purlin has at least two bolts in each purlin-to-rafter connection
- (d) The depth of the purlin section is not less than 0.25 times the depth D of the rafter.

Lateral restraint of the bottom flange of the rafter should not be assumed at the point of contraflexure under other restraint conditions, unless a lateral restraint is actually provided at that point.

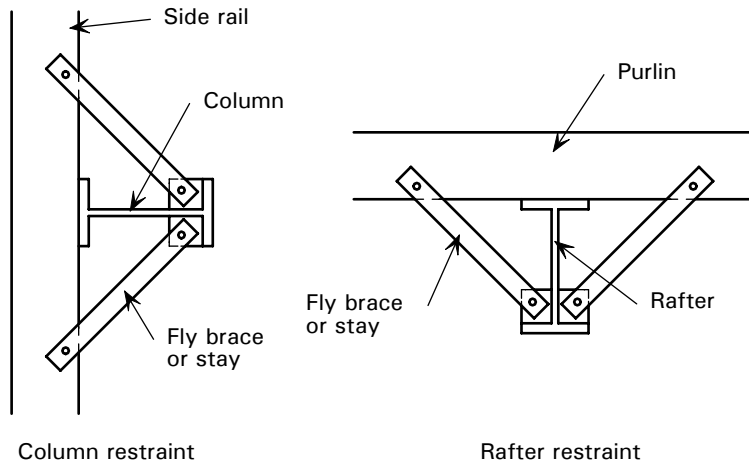


Figure 12.4 Fly brace for column and rafter

Location of torsional and lateral restraints

All plastic hinges locations should be torsionally restrained. The code requires that both flanges be laterally restrained in order to provide a torsional restraint. Where it is not possible to provide restraint exactly at the hinge location, restraint should be provided within a distance $D/2$ of the hinge location.

Cl. 5.3.2

The distance between the plastic hinge and the next required lateral restraint to the compression flange can be calculated by two methods:

Cl. 5.3.3

- A conservative method that does not allow for the shape of the moment diagram between the plastic hinge and the next torsional restraint.
- A more complex, but still approximate method, which does allow for shape of the moment diagram.

Conservative method

The distance between a plastic hinge and the next lateral restraint to the compression L_m should not exceed L_u given by:

Cl. 5.3.3(a)

$$L_u = \frac{38r_y}{\left[\frac{f_c}{130} + \left(\frac{x}{36} \right)^2 \left(\frac{p_y}{275} \right)^2 \right]^{0.5}}$$

where:

- f_c is the compressive stress in the rafter due to axial force (N/mm²)
- p_y is the rafter design strength (N/mm²)
- r_y is the radius of gyration of the rafter about the minor axis
- x is the torsional index of the rafter.

If the member has unequal flanges, r_y should be taken as the lesser of the value for the compression flange and for the whole section.

Approximate method allowing for moment gradient

For I section members with uniform cross-sections, equal flanges and $D/B \geq 1.2$ where f_c does not exceed 80N/mm^2 the limiting length L_m is given by: Cl. 5.3.3(b)

$$L_m = \phi L_u$$

In which case L_u is as given above and ϕ is given as follows:

$$\text{For } 1 \geq \beta \geq \beta_u \quad \phi = 1$$

$$\text{For } \beta_u > \beta \geq 0 \quad \phi = 1 - (1 - K K_0)(\beta_u - \beta)/\beta_u$$

$$\text{For } 0 \geq \beta > -0.75 \quad \phi = K(K_0 - 4(1 - K_0)\beta/3)$$

$$\text{For } \beta \leq -0.75 \quad \phi = K$$

Where β is the ratio of end moments of the segment under consideration and β_u is given by:

$$\beta_u = 0.44 + \frac{x}{270} - \frac{f_c}{200} \quad \text{for S275 steel}$$

$$\beta_u = 0.47 + \frac{x}{270} - \frac{f_c}{250} \quad \text{for S355 steel}$$

$$K_0 = (180 + x)/300$$

$$K = 2.3 + 0.03x - x f_c/3000 \quad \text{for } 20 \leq x \leq 30$$

$$K = 0.8 + 0.08x - (x - 10) f_c/2000 \quad \text{for } 30 \leq x \leq 50$$

Segments with one flange restrained

Where one flange is restrained between torsional restraints, the distance between torsional restraints may be increased provided that: Cl. 5.3.4

- Adjacent to a plastic hinge location the distance to the next intermediate lateral restraint does not exceed L_m as given above.
- Member buckling resistance check (Cl. 4.8.3.3 or Annex I.1) should be satisfied for out-of-plane buckling when checked using an effective length equal to the spacing of intermediate lateral restraints (spacing need not be less than L_m).

For the simplified method to be applicable, the following conditions should be satisfied:

- The member is an I section with $D/B \geq 1.2$
- For haunched segments $D_h \leq 2D_s$
- For haunches the haunch flange is not smaller than the member flange
- The steel grade is S275 or S355

The limiting spacing L_s between restraints to the compression flange is given by:

$$L_s = \frac{620 r_y}{K_1 (72 - (100/x)^2)^{0.5}} \quad \text{for S275 steel}$$

$$L_s = \frac{645 r_y}{K_1 (94 - (100/x)^2)^{0.5}} \quad \text{for S355 steel}$$

where:

$K_1 = 1.0$ for an un-haunched segment

$K_1 = 1.25$ for a haunch with $D_h/D_s = 1$

$K_1 = 1.4$ for a haunch with $D_h/D_s = 2$

$K_1 = 1 + 0.25(D_h/D_s)^{2/3}$ for a haunch generally

r_y is the minor axis radius of gyration of the un-haunched rafter

x is the torsional index the un-haunched rafter.

Haunches

The code provides design guidance for the case of plastic hinges occurring immediately adjacent to one end of either two- or three-flange haunches, see Figure 12.5.

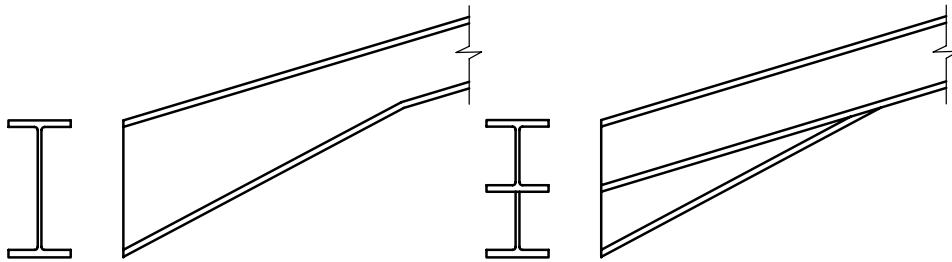


Figure G.2

Figure 12.5 Two- and three-flange haunches

Three-flange haunches

The tapered segment need not be treated as a segment adjacent to a plastic hinge, provided the following are satisfied:

- The tapered segment remains elastic throughout its length
- Top and bottom flanges of the tapered segment have lateral restraint within a distance of $D/2$ of the plastic hinge location

Cl. 5.3.5.1

Two-flange haunches

The tapered segment should satisfy at least one of the following criteria:

- The moment at the lateral restraint adjacent to the plastic hinge location does not exceed 85% of the reduced plastic moment capacity M_{cr} at that location

The length L_y to the adjacent lateral restraint to the compression flange does not exceed the limiting length L_m or L_s (see above).

12.6 Summary of design procedure

- | | |
|--|-------------|
| 1. Select steel grade and trial sections (see Appendix A) | |
| 2. Check in-plane stability of frame ($\lambda_p \geq \lambda_r$) using: | Cl. 5.5.3 |
| • Sway check method, or | Cl. 5.5.4.1 |
| • Amplified moments method, or | Cl. 5.5.4.4 |
| • Second-order analysis | Cl. 5.5.4.5 |
| 3. Check out-of-plane stability of frame | Cl. 5.5.1 |
| 4. Check in-plane stability of members | Cl. 5.2.3.1 |
| 5. Check out-of-plane stability of members | Cl. 5.3.1 |
| Determine limiting segment length for: | |
| (a) Segment adjacent to plastic hinge (L_m) | Cl. 5.3.3 |
| (b) Member or segment with one flange restrained (L_s) using: | |
| – Simple method, or | Cl. 5.3.4 |
| – Annex G approach | Annex G.3 |
| 6. Check deflections | Table 8 |
| 7. Design connections and bases to transmit forces and moments. | |

13 PLATE GIRDERS

13.1 Introduction

The high bending moments and shear forces associated with carrying large loads over long spans will frequently exceed the capacity of universal beam sections. In this situation, plate girders may be fabricated, their proportions being designed to provide a high strength to weight ratio.

In a fabricated plate girder, the primary function of the flanges is to resist axial compressive and tensile forces arising from the bending moments. The primary function of the web is to resist the shear force. For an efficient plate girder design, the web depth d should be increased as far as possible to give the lowest flange force for a given bending moment. To reduce self-weight, the web thickness t should be reduced to a minimum. The consequence of these requirements is that the web has a high d/t ratio and tends to buckle in shear if stiffeners are not provided.

For an economic design, advantage should be taken of the post buckling reserve of strength commonly known as “tension field action”. BS 5950-1 does allow this reserve of strength to be taken into account. It is inevitable that the increased efficiency of designs to BS 5950-1 leads to some additional complexity of design calculations. There are special requirements for the ends of the plate girders in order to anchor the “tension field action”. A typical plate girder is shown in Figure 13.1.

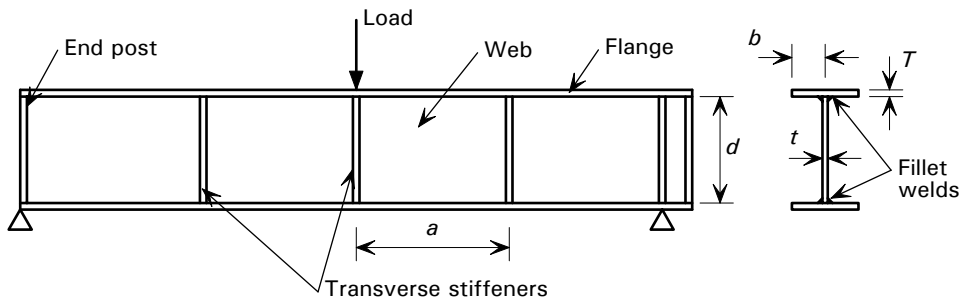


Figure 13.1 Typical plate girder with transverse stiffeners

The designer has to make the following decisions:

- Depth of girder (Generally, span/8 to span/16 is a reasonable depth range, where no other restrictions exist.)
- Size of flange plates
- Web thickness
- Stiffener spacing

BS 5950-1 Clause 4.4 and Annex H contain all the provisions for the design of plate girders. All plate girders in buildings, with or without transverse stiffeners, should be designed using Clause 4.4.

Cl. 4.4

Cl. 4.4
Annex H

13.2 General considerations

The slenderness at which web plates become prone to shear buckling is given as 62ε in the Code. The following discussion will concentrate on the more common case of plate girders with thin webs ($d/t > 62\varepsilon$), where shear buckling must be taken into account. Guidance on shear buckling is provided in Section 13.6.

Cl. 4.4.4.2

The buckling resistance of thin webs can be increased by the provision of web stiffeners. In general webs may be:

- Without intermediate stiffeners
- With transverse stiffeners only
- With transverse and longitudinal stiffeners

BS 5950 gives no specific consideration to plate girders with longitudinal stiffeners. For plate girders with longitudinal stiffeners, which are rare in buildings, the designer should refer to the design code for steel bridges, BS 5400-3^[55].

Cl. 4.4.5.1

Local buckling of the compression flange may occur (see Section 3) if the flange plate is of slender proportions i.e. $b/T > 13\varepsilon$. However, flanges of such slender proportions will probably be rare in buildings, since there would seldom appear to be a good reason to exceed the specified outstand b in normal design.

Table 11

Lateral torsional buckling considerations for plate girders are similar to those described earlier for beams (Section 7). Lateral torsional buckling will not be considered further in this section i.e. it is assumed that full lateral restraint is provided to the plate girder.

To summarise, this Section will concentrate on the design of what are considered to be typical plate girders. Such girders will have:

- Thin webs ($d/t > 62\varepsilon$) either with or without transverse stiffeners
- Non-slender flanges ($b/T < 13\varepsilon$)
- Full lateral restraint.

Cl. 4.2.2

Plate girders must be designed to have sufficient capacity to carry the moments and shears applied. It should be noted that certain minimum limits are imposed upon the web thickness (see Section 13.4) and that the required capacity must be achieved whilst satisfying these limits.

13.3 Design strength

By using separate plates for webs and flanges it is possible to use different grades of steel in the web and the flanges. However, it is probable that even where a single grade of steel is used, the design strength p_y of the thinner web will be higher than that of the thicker flange, i.e. S275 steel has a design strength of 275 N/mm² when it is less than 16 mm thick and a design strength of 265 N/mm² when it is greater than 16 mm and less than 40 mm thick.

Table 9

The code requires that, if the web design strength is greater than the flange strength, then the flange strength should be used in all calculations, including section classification, except those for shear or forces transverse to the web, where the web strength may be used.

For hybrid plate girders where the web design strength is less than the flange design strength, both strengths may be used when considering moment or axial force, but the web strength should be used in all calculations involving shear or forces transverse to the web. The section classification should be based on the design strength of the flanges.

Table 11
Note (c)

13.4 Minimum requirements for webs

The designer has to make decisions about the dimensions of webs and flanges based on architectural considerations as well as structural efficiency. The ability to choose efficient sections can be a matter of trial and error based on experience.

However, the code does have some limitations, to ensure that: (1) the web is robust enough to be fabricated and handled and (2) the compression flange does not buckle into the web. These limitations are:

(1) Minimum web thickness for serviceability:

Cl. 4.4.3.2

- for webs without transverse stiffeners $t \geq d/250$
- for webs with transverse stiffeners:
 - where the stiffener spacing $a > d$ $t \geq d/250$
 - where the stiffener spacing $a \leq d$ $t \geq (d/250)(a/d)^{0.5}$

(2) Minimum web thickness to avoid compression flange buckling into the web:

Cl. 4.4.3.3

- for webs without transverse stiffeners $t \geq (d/250)(p_{yf}/345)$
- for webs with transverse stiffeners:
 - where the stiffener spacing $a > 1.5d$ $t \geq (d/250)(p_{yf}/345)$
 - where the stiffener spacing $a \leq 1.5d$ $t \geq (d/250)(p_{yf}/445)^{0.5}$

where:

p_{yf} is the design strength of the compression flange

All other terms are as defined in Figure 13.1.

In practice, these rules allow the use of very thin webs and impose little restriction on the design of plate girders.

13.5 Moment capacity

13.5.1 Webs not susceptible to shear buckling

Cl. 4.4.4.1

If the web depth to thickness ratio (d/t) is less than or equal to 62ε (70ε for rolled sections) the web is not susceptible to shear buckling and the moment capacity should be calculated using the normal methods for restrained beams in covered in Section 6.5 of this publication or Clause 4.2.5 of BS 5950-1.

13.5.2 Webs susceptible to shear buckling

Cl. 4.4.4.2

If the plate girder web depth to thickness ratio (d/t) is greater than 62ε (70ε for rolled sections) the web is susceptible to shear buckling.

The web will initially buckle at the critical shear buckling strength q_{cr} but due to “tension field action” there will be considerable reserves of shear strength. The post-buckled shear buckling resistance, described in the code as the simple shear buckling resistance, is given by:

$$V_w = d t q_w$$

Cl. 4.4.5.2

where:

q_w is web shear buckling strength, given in Table 21 of BS 5950-1 and depends on the d/t of the web and the a/d of the web panel

All other terms are as defined in Figure 13.1.

When the applied shear reaches the shear buckling resistance V_w the web will already be buckled. Although the section is still capable of carrying further shear in its buckled state provided the flanges are not fully stressed, the ability of the web to take part in resisting bending moment or longitudinal compression is significantly reduced.

Any cross-section of the plate girder will normally be subjected to a combination of shear force and bending moment, present in varying proportions. The code allows one of the following three methods to be used to determine the moment capacity at a section:

Cl. 4.4.4.2

(a) Low shear

If the applied shear is less than or equal to 60% of the simple shear buckling resistance V_w then the moment capacity may be obtained as for rolled beam sections, see Figure 13.2. When using these rules, the section should be classified and if appropriate effective section properties should be calculated. For the section classification, the value of ε should be based on the design strength of the flanges.

Cl.
4.4.4.2 a)

(b) High shear – “flanges only” method

If the applied shear is greater than 60% of V_w , the section can conservatively be designed by taking the entire shear on the web and the moment on the flanges. The uniform stress in the flanges should not exceed p_{yf} , as shown in Figure 13.3. For this approach, the flanges must not be Class 4 slender.

Cl.
4.4.4.2 b)

(c) High shear – general method

Alternatively, if the applied shear is greater than 60% of V_w , the web can be used to contribute to the moment capacity (as shown in Figure 13.4), provided that the applied moment does not exceed the low shear moment capacity given in Clause 4.2.5.2 of BS 5950-1. This method is described in detail in Annex H of BS 5950-1.

Cl.
4.4.4.2 c)
Annex H

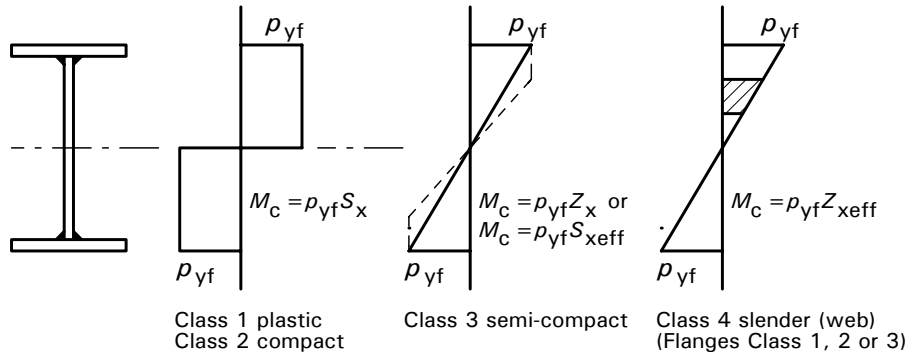


Figure 13.2 Moment capacity of plate girders with $d/t \geq 62\epsilon$ and low shear

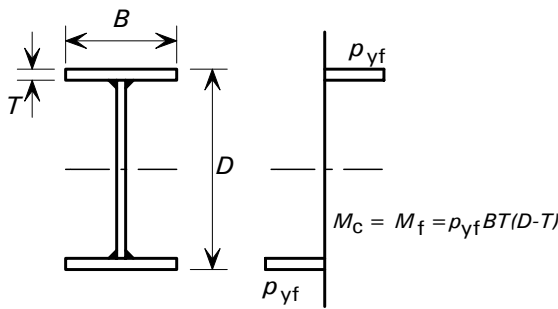


Figure 13.3 Moment capacity of plate girders with $d/t \geq 62\epsilon$ and high shear using the "flanges only" method

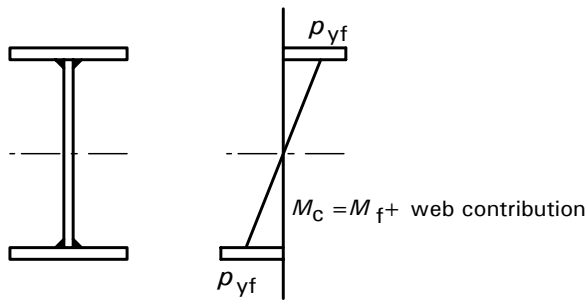


Figure 13.4 Moment capacity of plate girders with $d/t \geq 62\epsilon$ and high shear using the general method

The separation of moment and shear effects in Method (b) leads to considerable simplification and a better physical appreciation of the load carrying action. Although slightly conservative, it will probably be the most commonly used method. It is not insignificant that details of method (c) are relegated to Annex H of the code.

If the plate girder is also subject to an axial force, the value of M_f should be calculated by assuming the axial load and moment are both resisted by the flanges alone; uniform stress in each flange should not exceed p_{yf} . The relevant interaction expressions covered in Section 9.4 should also be satisfied.

13.6 Shear buckling resistance

The shear buckling resistance should be checked if the d/t of the web exceeds 62ε for a welded plate girder (70ε for a rolled section).

The following methods are given by the code for webs designed to carry shear only. Those that are used to resist axial load or some bending should be checked using Annex H of BS 5950-1.

13.6.1 Simplified method.

This method must be used for webs without stiffeners and may also be used for webs with vertical stiffeners. Webs with horizontal stiffeners should be designed using the design standard for bridges BS 5400-3^[55].

The shear buckling resistance V_b of the web panel should be based on the simplified shear buckling resistance V_w as given by:

$$V_b = V_w = d t q_w$$

where:

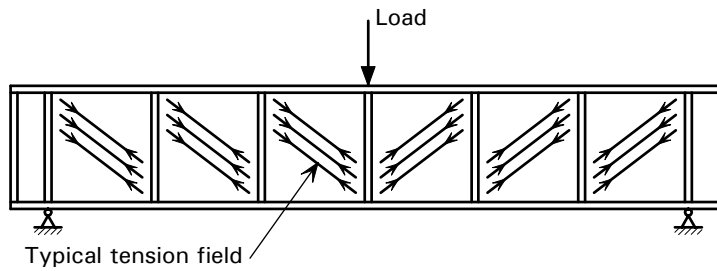
d is the depth of the web

t is the thickness of the web

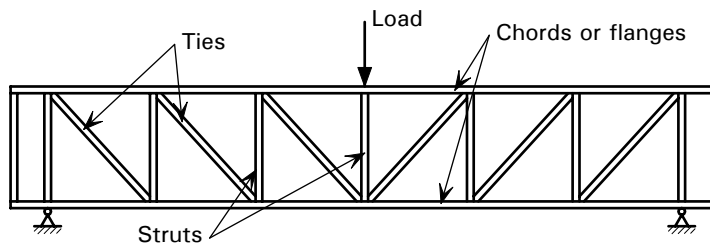
q_w is the web shear buckling strength given in Table 21 of BS 5950-1

The stress q_w is the post-buckled strength of the web panel. This post-buckling reserve of strength arises from the development of “tension field action” within the web plate and advantage should be taken of this action to achieve an effective design.

Figure 13.5.a) shows the development of tension field action in a typical plate girder. Once a web panel has buckled it loses its capacity to carry additional compressive stresses. In this post-buckled range, a new load carrying mechanism is developed, whereby an inclined tensile membrane stress field carries any additional shear load. This tensile field anchors against the top and bottom flanges and against the transverse stiffener on either side of the web panel, as shown in Figure 13.5.a). The load carrying action of the plate girder becomes similar to that of an N girder truss in Figure 13.5 b). The action of the web panels is analogous to that of the diagonals of the truss.



a) Tension field action in plate girder web panels



b) Typical N truss

Figure 13.5 Plate girder tension field action comparison with N girder truss

The simplified method assumes that the flanges play no part in resisting shear forces.

13.6.2 More exact method

The more exact method considers the situation at collapse beyond the post-buckling phase of the simplified method. Figure 13.6 shows that failure occurs when the web yields and four plastic hinges form in the flanges to allow the development of a collapse mechanism. The contribution of the flanges to the post-buckling strength is given by V_f , see below.

The more exact method assumes that the flanges can play a part in resisting the shear. The stress in the flange due to axial load and/or bending as well as the strength of the flange must therefore be considered.

If the flange is fully stressed due to axial load and/or bending then the shear buckling resistance must be obtained using the simplified method.

If the flanges are not fully stressed, then both the web (V_w) and the flange (V_f) can contribute to the shear buckling resistance V_b given by:

$$V_b = V_w + V_f \quad \text{but } V_b \leq P_v$$

where:

$$V_w = d t q_w$$

$$V_f = \frac{P_v (d/a) \left[1 - (f_f / p_{yf})^2 \right]}{1 + 0.15 (M_{pw} / M_{pf})}$$

Cl. 4.4.5.3

f_f is the mean longitudinal stress in the smaller flange due to moment and/or axial force

M_{pf} is the plastic moment capacity of the smaller flange about its own equal area axis perpendicular to the plane of the web i.e. $BT^2p_{yf}/4$

M_{pw} is the plastic moment capacity of the web about its own equal area axis perpendicular to the plane of the web i.e. $td^2p_{yw}/4$

P_v is the shear resistance of the section

All other dimensions are as defined in Figure 13.1.

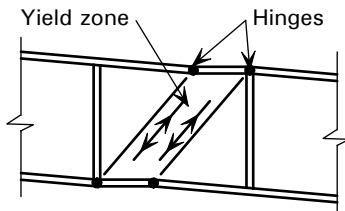


Figure 13.6 Collapse of a typical plate girder web panel in shear

It is important to recognise that use of the simplified and more exact methods apply to individual web panels and both methods may be used in the design of the entire plate girder. For example the simplified method may be used towards the centre of a simply supported girder (where the shear forces are low and the flange forces high) and the more exact method may be used towards the end of the girder where the opposite is true.

13.6.3 End anchorage

Tension field forces can only develop when the members bounding the panel provide adequate anchorage. This is a particular problem at the ends of a girder where the anchorage has to be provided by the end stiffener.

Cl. 4.4.5.4

Due to the nature of the tension field action, there will be a horizontal force H_q at the end of the girder, as shown in Figure 13.7. Special provisions to resist the anchor force H_q will be required unless one of the following conditions applies:

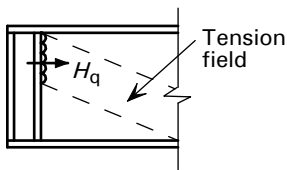


Figure 13.7 Anchorage force

- The shear capacity, rather than the shear buckling resistance is the governing criteria in the end panel i.e. $V_w = P_v$. This is generally the case when using a web with a low d/t ratio.
- A tension field is not formed i.e. $F_v \leq V_{cr}$. This is generally the case with a low shear or small stiffener spacing.

V_{cr} is the critical shear buckling resistance of the panel which is given by:

$$V_{cr} = P_v \quad \text{if } V_w = P_v$$

$$V_{cr} = (9V_w - 2P_v)/7 \quad \text{if } P_v > V_w > 0.72P_v$$

$$V_{cr} = (V_w/0.9)^2/P_v \quad \text{if } V_w \leq 0.72P_v$$

In all other cases, anchorage should be provided in accordance with the recommendations of Annex H.4 of the Code. The Code offers three methods of providing end anchorage.

1. Single stiffened post (see Figure 13.8)

The single end stiffener spanning vertically between the flanges has to resist the tension field pull of panel B. This requirement represents a significant demand on the capacity of the single stiffener.

Annex
H.4.2

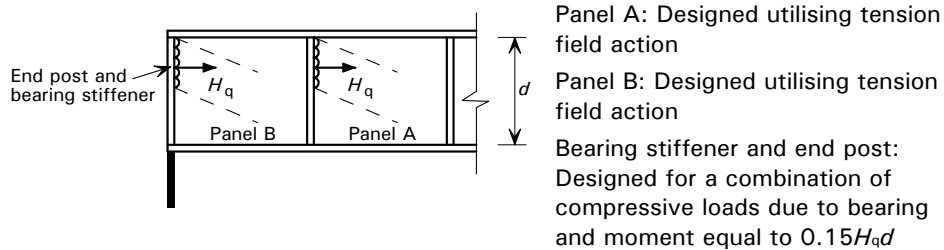


Figure H.2
Annex
H.4.2

Figure 13.8 Single stiffened end post

2. Twin stiffened post (see Figure 13.9)

A double stiffener may be used to form a rigid end post in which the two stiffeners and the portion of the web projecting beyond the support now form the vertically spanning beam. In this case adequate space must be available to allow the girder to project beyond its support.

Annex
H.4.3

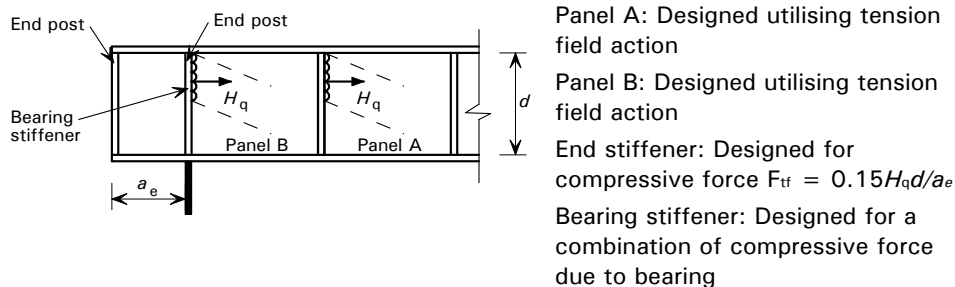


Figure H.3
Annex
H.4.3

Figure 13.9 Twin stiffened end post

3. Anchor panel (see Figure 13.10)

This approach has the advantage of providing a substantial end member. However, the additional shear capacity that could be derived from tension field action in the end panel is omitted. Usually the region adjacent to the support has the highest shear forces. To prevent the calculated shear capacity of panel B being much lower than that of panel A, the intermediate stiffener would have to be positioned close to the support to make B a narrow panel.

Annex
H.4.4

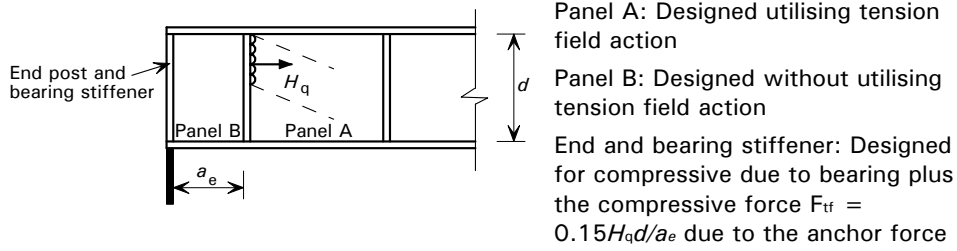


Figure 13.10 Anchor panel

Each of the three alternatives shown in Figures Figure 13.8, Figure 13.9 and Figure 13.10 has certain disadvantages. However, the inclusion of each in the Code enables to most appropriate to be chosen for each particular design situation.

13.6.4 Panels with openings

Web openings frequently have to be provided in plate girders used in buildings for the integration of services. Where all the dimensions of the opening are less than or equal to 10% of the smaller panel dimension, their existence may be ignored (see Figure 13.11).

Cl. 4.4.5.5

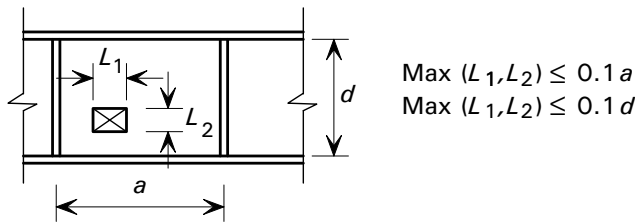


Figure 13.11 Limits on the size of openings

Where the opening is greater than 10% of the smaller panel dimension reference should be made to Clause 4.15 of the code, which gives further recommendations. Panels with such openings should not be used as anchor panels and the immediately adjacent panels should be designed as end panels, as outlined in Section 13.6.3.

13.7 Stiffeners

The use of slender webs in plate girders means that a number of stiffeners may be required for different purposes. Stiffeners may fulfil more than one function but it is helpful to think of these individual functions separately then combine the checks as necessary.

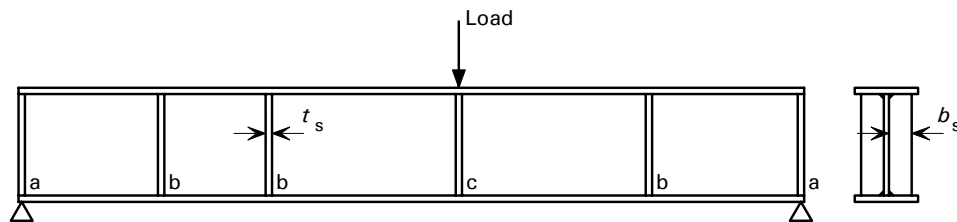


Figure 13.12 Types of stiffener

Types of stiffener shown in Figure 13.12 are as follows:

- Bearing stiffener / load carrying stiffener / end post
- Intermediate transverse stiffener
- Intermediate transverse stiffener / load carrying stiffener / bearing stiffener

Each of these types of stiffener will be subjected to compression and should be checked for local buckling.

13.7.2 Maximum outstand

Stiffeners will usually be in compression, and to prevent local buckling, the stiffener outstand b_s must be restricted. This would usually be limited to $13\epsilon t_s$ in accordance with Table 11 of BS 5950-1. However in order to allow slightly greater outsands for connection of transverse members the code states that the maximum outstand should not exceed $19\epsilon t_s$. If the outstand is between $13\epsilon t_s$ and $19\epsilon t_s$ then the design should be based on an effective outstand $13\epsilon t_s$.

13.7.3 Bearing stiffeners

Where loads or reactions are applied through the flange of a girder the web should be checked to ensure that it does not fail in bearing as shown in Figure 13.13. Details of this check are given in Section 8 on beam web design. Due to the thin ($d/t > 62\epsilon$) webs usually used in plate girder design it is usual to provide a stiffener at the position of a point load to prevent bearing failure.

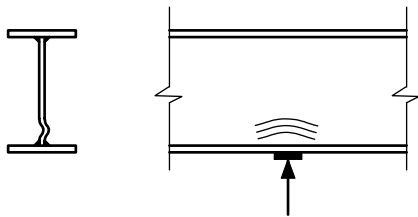


Figure 13.13 *Bearing failure of unstiffened web*

If the check indicates that the web may fail in bearing, then a bearing stiffener should be provided. The stiffener should be checked to ensure that it can carry the applied load less the capacity of the unstiffened web.

The capacity of the stiffener should be taken as:

$$P_s = A_{\text{snet}} p_y$$

In which A_{snet} is the net area of contact between the stiffener and flange allowing for cope holes as shown in Figure 13.14.

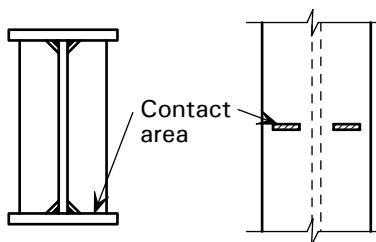


Figure 13.14 *Bearing stiffener*

Cl. 4.5.1.2

Cl. 4.5.2

Cl. 4.5.2.2

13.7.4 Load carrying stiffeners

Load carrying stiffeners are provided to prevent the web buckling as a strut under the applied load or reaction, as shown in Figure 13.15. Details of how to check the unstiffened web are given in Section 8. When checking for buckling, an effective web width of $15t$ on either side of the centreline of the stiffener is considered to act with the stiffener to form a cruciform section.

Cl. 4.5.3.3

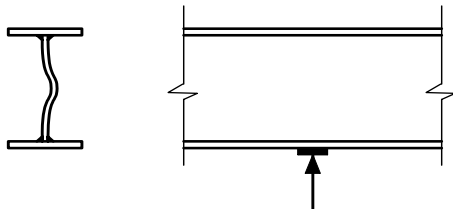


Figure 13.15 Buckling failure of an unstiffened web

The buckling resistance of a load carrying stiffener (cruciform section as shown in Figure 13.16) is given by:

Cl. 4.5.3.3

$$P_x = A_s p_c$$

where:

- A_s is the effective area, as shown in Figure 13.16 and includes part of the web
- p_c is the compressive strength obtained from Table 24 of BS 5950-1 using strut curve c based on the design strength p_y and slenderness λ
- $\lambda = L_E/r$
- L_E is the effective length (see below)
- r is the radius of gyration of the effective area $= (I_s/A_s)^{0.5}$
- I_s is the second moment of area of the effective area about the centreline of the web
- $I_s = t_s(2b_s + t_w)^3/12 + (30t_w - t_s)t_w^3/12.$

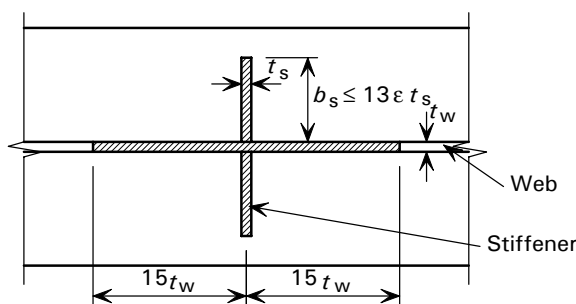


Figure 13.16 Effective area of load carrying stiffener

For cases where the flanges are restrained against relative lateral movement, the effective length L_E should be taken as:

- If the flange is restrained against rotation in the plane of the stiffener, the effective length may be taken as $0.7d$
- If the flange is not so restrained then the effective length should be taken as $1.0d$.

13.7.5 Intermediate transverse stiffeners

The need for intermediate transverse stiffeners and their required spacing is dictated by the rules for web shear design discussed in Sections 13.6.1 and 13.6.2. In practice the spacing is often imposed by the location of point loads and/or the geometry of the section.

Cl. 4.4.6
Cl. 4.5.5

The function of intermediate transverse stiffeners is to prevent the web buckling out of plane at the stiffener location. In order to do this it must have adequate stiffness and strength.

Minimum stiffness

Cl. 4.4.6.4

Stiffeners not subject to external loads should have a minimum second moment of area about the centreline of the web of I_s , given by:

$$I_s = 0.75dt_{\min}^3 \quad \text{if } a/d \geq \sqrt{2}$$

$$I_s = 1.5(d/a)^2dt_{\min}^3 \quad \text{if } a/d < \sqrt{2}$$

Where t_{\min} is the minimum required web thickness for the actual stiffener spacing a . The actual web thickness may conservatively be used instead of t_{\min} .

For most normally proportioned stiffeners, these requirements are easily met.

Example

For the stiffener (alone) shown in Figure 13.16, the second moment of area, $I_s = t_s(2b_s + t_w)^3/12$.

If $b = 150$ mm, $t_w = 15$ mm, $t_s = 15$ mm, $d = 1200$ mm and $a = 1000$ mm then the second moment of area of the stiffener I_s equals 39.07×10^6 mm⁴ and $a/d = 0.83$ which is $< \sqrt{2}$, therefore

$$\begin{aligned} I_{s,\text{required}} &= 1.5(d/a)^2dt_{\min}^3 \\ &= 1.5(1.2)^2 \times 1200 \times 15^3 \\ &= 8.75 \times 10^6 \text{ mm}^4 < 39.07 \times 10^6 \text{ mm}^4 \therefore \text{OK} \end{aligned}$$

Stiffeners subject to external loads

Cl. 4.4.6.5

If the stiffener is subject to external loads the required value of I_s should be increased by adding I_{ext} as given by:

- $I_{\text{ext}} = 0$, if an external force is applied in line with the web, see Figure 13.17(a)
- $I_{\text{ext}} = F_x e_x D^2/(E \times t)$, if an external force is applied at an eccentricity e_x from the centreline of the web, see Figure 13.17(b)
- $I_{\text{ext}} = 2F_h D^3/(E \times t)$, if a lateral force is deemed to be applied at the level of the compression flange, see Figure 13.17(c)

Where E is the elastic modulus of steel. All other terms are as defined in Figure 13.17.

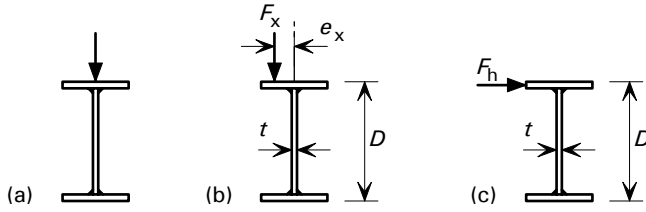


Figure 13.17 Transverse stiffeners with external loads

Stiffener strength

Designing for tension field action imposes additional compressive forces on the intermediate transverse stiffeners, therefore the stiffeners (cruciform section as shown in Figure 13.16) must be designed as a strut and checked for buckling.

Cl. 4.4.6.6

The stiffener strength requirement is that the applied force $F_q \leq$ the buckling resistance of the intermediate web stiffener P_q .

The applied force is given by:

$$F_q = V - V_{cr}$$

where:

- V is the maximum shear in either of the panels adjacent to the stiffener
- V_{cr} is the critical shear buckling resistance of the same panel, given in Section 13.6.3 above and Clause 4.4.5.4b) of the code

The buckling resistance of the intermediate stiffener P_q should be calculated as for P_x (Section 13.7.4) except the effective length is taken as $0.7d$.

Cl. 4.5.5

If the stiffener is subject to external forces it should satisfy the requirements for a load carrying stiffener (see Section 13.7.4) and in addition should meet the following criteria:

$$\text{If } F_q > F_x \quad \text{then} \quad \frac{F_q - F_x}{P_q} + \frac{F_x}{P_x} + \frac{M_s}{M_{ys}} \leq 1$$

$$\text{If } F_q \leq F_x \quad \text{then} \quad \frac{F_x}{P_x} + \frac{M_s}{M_{ys}} \leq 1$$

where:

$$M_s = F_x e_x + F_h D \quad (\text{see Figure 13.17})$$

13.7.6 Connection to the web

Cl. 4.4.6.7

Where the intermediate transverse stiffener is not subject to external forces, the weld connecting the stiffener to the web should be designed to carry a shear of $t^2/5b_s$ kN/mm run. If the stiffener is subject to external forces, the resulting shear between the web and the stiffener should be added to the above value.

13.8 Loads applied between stiffeners

Where loads are applied between stiffeners, the applied stress f_{ed} on the web from the loading should not exceed the resistance of the web p_{ed} . If p_{ed} is exceeded, additional stiffeners should be provided.

Cl. 4.5.3.2

The stress f_{ed} on the panel edge should be calculated as follows (see Figure 13.18):

- For individual point loads and distributed loads shorter than the smaller panel dimension (a or d), the load should be divided by the smaller dimension to give a force in N/mm
- For a series of point loads equally spaced, divide the largest load by the lesser of the spacing and the smaller panel dimension to give a force in N/mm
- Add the force per mm of any distributed load which extends more than the smaller panel dimension to the value calculated from (a) or (b)

Divide the sum of a), b) and c) as appropriate by the thickness of the web t to give the stress f_{ed} in N/mm^2 .

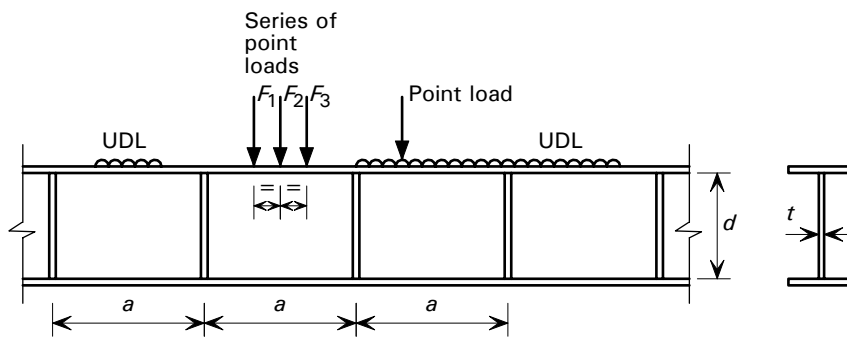


Figure 13.18 *Loads between stiffeners*

The compressive strength for edge loading p_{ed} should be calculated as follows:

- If the compression flange is restrained against rotation relative to the web:

$$p_{ed} = \left[2.25 + \frac{2}{(a/d)^2} \right] \frac{E}{(d/t)^2}$$

- If the compression flange is not so restrained:

$$p_{ed} = \left[1.0 + \frac{2}{(a/d)^2} \right] \frac{E}{(d/t)^2}$$

13.9 Summary of design procedures

The following procedures are applicable to plate girders with $d/t > 62\varepsilon$, where the girder is restrained laterally along its length:

- | | |
|--|-------------|
| 1. Calculate the factored moment. | |
| 2. Choose a girder depth based on the span. | |
| 3. Calculate approximate flange sizes. | |
| 4. Ensure flanges are preferably Class 1 plastic or Class 2 compact. | |
| 5. Choose a web thickness $>$ minimum value for serviceability. | Cl. 4.4.3.2 |
| 6. Check the moment capacity usually using the “flanges only” method. | Cl. 4.4.3.3 |
| 7. Establish stiffener spacing. | |
| 8. Since $d/t > 62\varepsilon$, check the shear buckling resistance, usually using the “simplified method”. | Cl. 4.4.5 |
| 9. Check end anchorage requirements. | Cl. 4.4.5.4 |
| 10. Check bearing stiffeners. | Cl. 4.5.2 |
| 11. Check web for any loads between stiffeners. | Cl. 4.5.3.2 |
| 12. Check weld sizes. | |

14 CONTINUOUS MULTI-STOREY FRAMES

14.1 Introduction

Building frames generally comprise an assembly of beams and columns. The connections between the beams and columns are commonly assumed to be pinned and not to transmit significant moments. In this case, resistance to lateral force is provided by vertical bracing, shear walls or a concrete core.

Alternatively, it may be assumed that the connections are rigid and moment-resisting and analysed assuming full continuity. Frames designed on this basis are called continuous (or rigid) frames. Continuous frames assume that joints are rigid and that no relative rotation of connected members occurs whatever the applied moment. The bending moment diagram (due to vertical loading) for a typical continuous frame is shown in Figure 14.1.

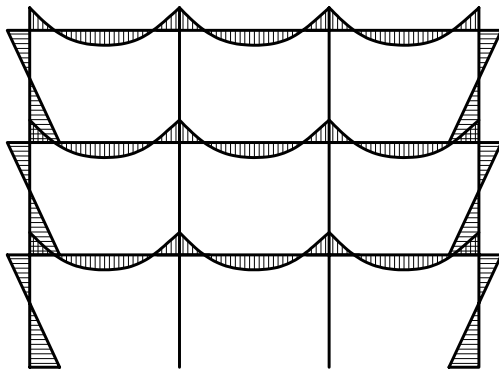


Figure 14.1 *Bending moment diagram for a continuous frame subject to vertical loading*

Frames may also be designed as 'semi-continuous', but this is beyond the scope of the present publication. Detailed design guidance for semi-continuous frames is provided in SCI publications P183^[3] and P263^[4].

Frame stability

In continuous frames, resistance to lateral forces is provided by frame action (i.e. by bending of beams and columns with moment resisting connections), which removes the need for vertical bracing. However, additional sway stability may be provided by an independent bracing system.

14.2 Loading

In addition to considering the standard load cases as described in Section 1.6.1, it is also necessary to consider pattern loading in continuous frames.

In order to ensure that the worst load effects are considered it is necessary to consider realistic combinations of pattern loading, see Figure 14.2. It is not necessary to vary the load factor of 1.4 on the dead load when considering pattern loading of imposed loads. The imposed floor load should be arranged in the most unfavourable but realistic pattern. Suggested combinations are shown in Figure 14.2. The designer should however, apply engineering judgement to each situation. The imposed roof loading should generally not be patterned for the gravity load case.

Cl. 5.1.2

Cl. 5.1.2.1

Cl. 5.1.2.2

Cl. 5.1.2.3

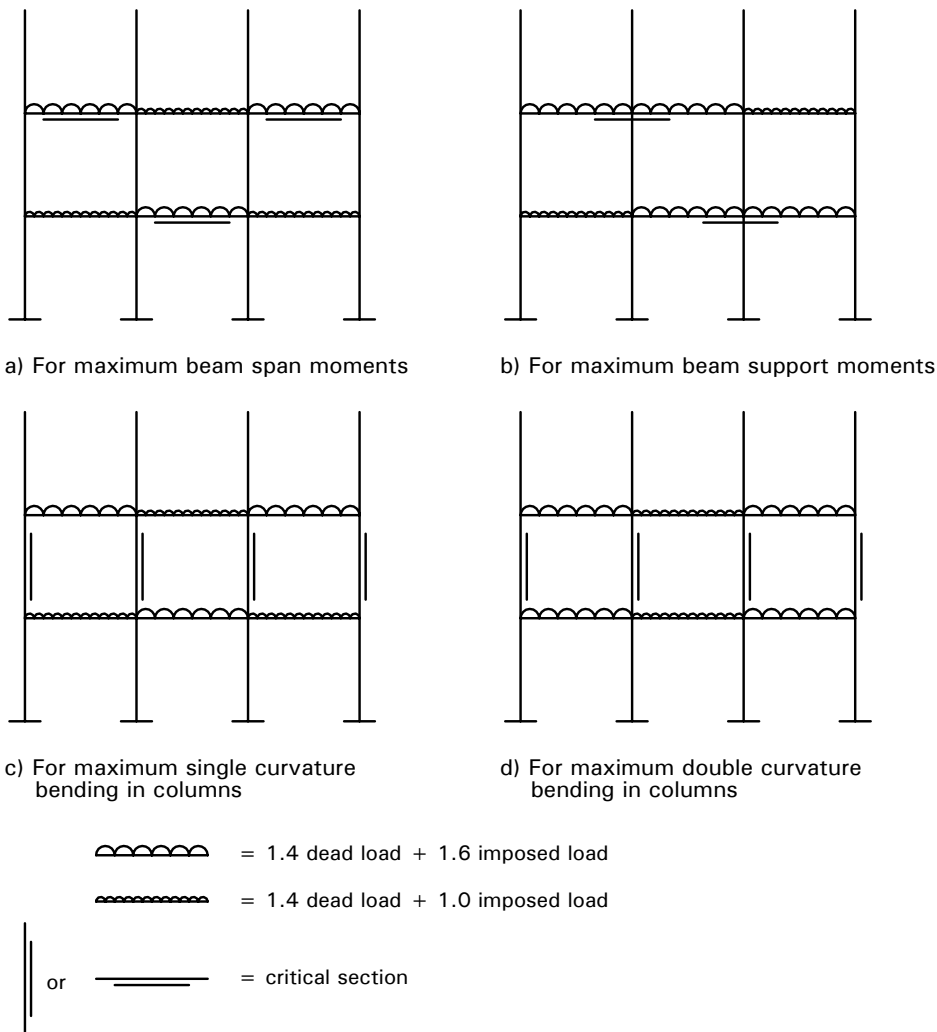


Figure 14.2 Pattern loading combinations

14.3 Frame analysis

Continuous frames, by their nature, are more difficult to analyse than simple (nominally pinned) frames. Either elastic or plastic analysis may be used to analyse continuous frames. Elastic analysis of rigid frames is usually carried out using one of the many commercial software packages now available. Most software will carry out a first order structural analysis. The software will calculate the moments and forces based on its un-deflected shape, ignoring any second-order effects due to sway.

Cl. 2.1.2.3

Second-order effects and the general method of allowing for them in design is discussed in Section 1.6.1. BS 5950-1 presents alternative methods of allowing for second-order effects in continuous structures in Section 5, Annex E and Annex F. These methods are explained further below.

Although the code covers plastic analysis of continuous frames it is rarely used for multi-storey frames. At the present there are no commercially available software packages to carry out such analysis.

Cl. 5.3.3

14.4 Connection properties

The connections between members must have different characteristics depending on whether the design method for the frame is elastic or plastic.

In elastic design, the joints must possess sufficient rotational stiffness (i.e rigid connections) to ensure that the distribution of forces and moments around the frame are not significantly different from those calculated. The joint must be able to carry the moments, forces and shears arising from the frame analysis.

Cl. 2.1.2.3

Cl. 6.1.5

In plastic design, when determining the ultimate load capacity, the strength (not stiffness) of the joint is of prime importance. The strength of the joint will determine whether plastic hinges occur in the joints or in the members, and will have a significant effect on the collapse mechanism. If hinges are designed to occur in the joints, the joint must be detailed with sufficient ductility to accommodate the resulting rotations. The stiffness of the joints will be important when calculating beam deflections, sway deflections and sway stability.

14.5 Frame classification

As for simple (nominally pinned) structures, continuous frames may be classified as “non-sway” frames or “sway-sensitive” frames, as explained in Section 1.6.3. “Non-sway” frames are defined in BS 5950-1 as frames for which the second-order effects are small enough to be ignored, and conversely, frames are classified as “sway-sensitive” frames if the second-order effects are significant to the design (see Section 1.6.3).

Cl. 2.4.2.6

14.5.1 Independently braced frames

Continuous multi-storey frames with an independent bracing system (as shown in Figure 14.3) that provides resistance to the horizontal forces may be classified as “non-sway” provided the details given below are satisfied.

Cl. 5.1.4

- The stiffness of the bracing system reduces the horizontal deflections of the frame by at least 80%, as shown in Figure 14.4.
- The bracing is designed to resist all horizontal loads and the notional horizontal forces applied to the whole frame. The notional horizontal loads should not be combined with other horizontal loads.

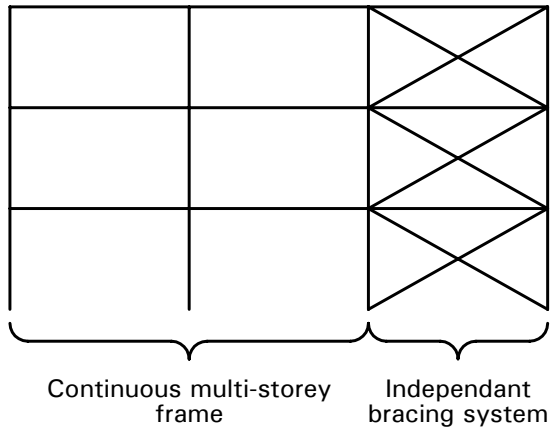


Figure 14.3 *Continuous multi-storey frame with an independent bracing system*

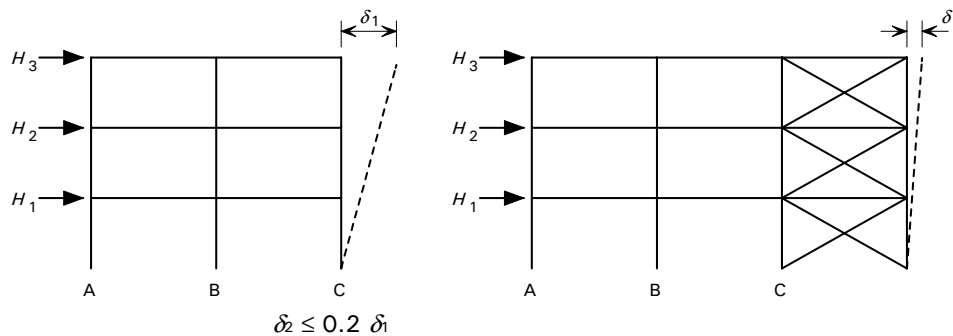


Figure 14.4 *Stiffness requirement for an independent bracing systems*

14.6 Elastic design of continuous multi-storey frames

14.6.1 Design of independently braced frames

Independently braced frames, as defined in Section 14.5.1 and Clause 5.1.4 of BS 5950-1, should be designed based on the following:

Cl. 5.6.2

- The frame should be designed to resist the gravity loads only (Load combination 1) i.e. no notional horizontal loads.
- The column in-plane effective lengths should be obtained from Annex E of BS 5950-1, based on the “non-sway” mode.
- Full and pattern loading should be used to determine the most severe moments and forces.
- Sub-frames may be used to reduce the number of load cases to consider under pattern loading.

14.6.2 Design of non-sway frames

Non-sway frames, as defined in Section 1.6.3 and Clause 2.4.2.6 of BS 5950-1, should be designed based on the following:

Cl. 5.6.3

- The frame should be designed to resist the gravity loads (Load combination 1, see Section 1.6.1), by considering both full and pattern loading
- The frame should be designed to resist combined gravity loads and horizontal loads (Load combinations 2 and 3, see Section 1.6.1), without pattern loading
- The column in-plane effective lengths should be obtained from Annex E of BS 5950-1, based on the non-sway mode
- Sub-frames may be used to reduce the number of load cases to consider under pattern loading

Figure 14.5 shows the deflected shape of a non-sway frame.

Cl. 5.1.4

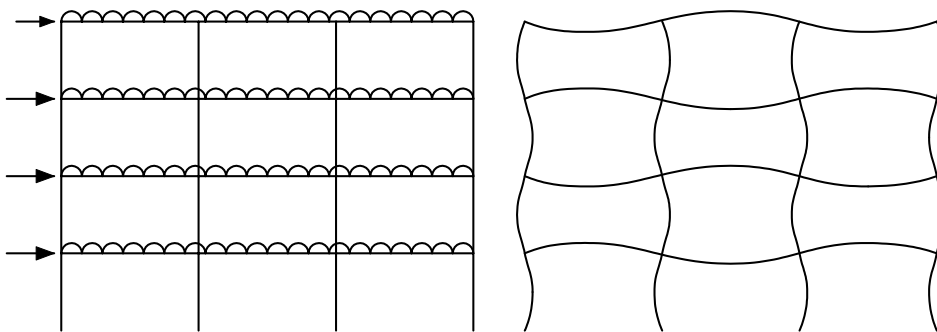


Figure 14.5 *Non-sway continuous frame*

14.6.3 Design of sway sensitive frames

Sway-sensitive frames, as defined in Section 1.6.3 and Clause 2.4.2.6 of BS 5950-1, should be designed based on the following:

Cl. 5.6.4

- Initially the frame should be designed in the non-sway mode, to resist the gravity loads (Load combination 1, see Section 1.6.1) as for an independently braced frame i.e. without notional horizontal forces or allowing for sway effects but with pattern loading
- The frame should then be designed in the sway mode, to resist the gravity loads (Load combination 1, see Section 1.6.1) plus the notional horizontal forces, allowing for sway effects but without pattern loading
- The frame should also be designed in the sway mode, to resist combined gravity loads and horizontal loads (Load combinations 2 and 3, see Section 1.6.1) i.e. allowing for sway effects but without pattern loading

Allowing for sway effects

For all values of λ_{cr} , second-order analysis may be carried out to allow for the sway effects. Alternatively the code allows one of the following two methods to be used, provided that $\lambda_{cr} \geq 4.0$.

Cl. 5.6.4

- The effective length method, in which the columns should be designed using the sway mode in-plane effective lengths obtained from Annex E of BS 5950-1 (see Section 14.6.4) and the beams are designed to remain elastic under factored loads. The code is not clear as to what is meant by “beams to remain elastic”; a reasonable interpretation is that beam moment $\leq 0.9 M_{pr}$, where M_{pr} is the reduced plastic moment capacity in the presence of axial force.
- The amplified sway method, in which the sway moments should be amplified by k_{amp} (as described in Section 1.6.3) and the columns should be designed using the non-sway mode in-plane effective lengths obtained from Annex E of BS 5950-1 (see Section 14.6.4)

If $\lambda_{cr} < 4.0$ a second-order elastic analysis must be used to account for the sway effects.

Figure 14.6 shows the deflected shape of a sway-sensitive frame.

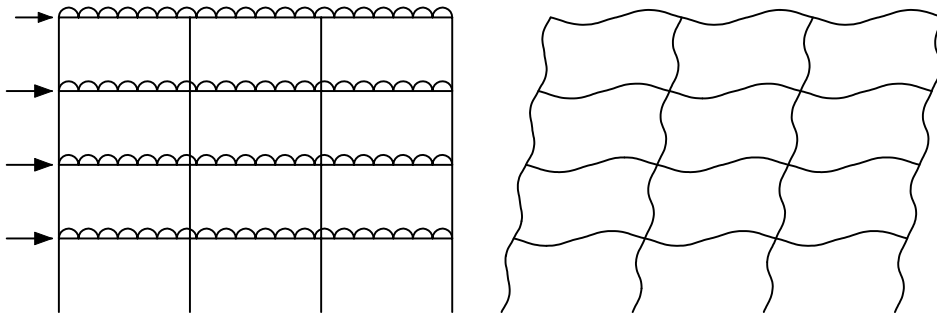


Figure 14.6 Sway-sensitive continuous frame

14.6.4 Column effective lengths

The effective length of a member is defined as that length which, if it were pin-ended, would behave as the real member with its actual end conditions. In a continuous frame, the end conditions are dependant on the stiffness of the members meeting at the joint.

The effective length of columns forming part of a continuous structure should be obtained from Annex E, and not from Table 22 of BS 5950-1. Annex E presents two charts that permit the designer to consider the full spectrum of end restraint combinations. The approach is based on the consideration of a limited frame (as shown in Figure 14.7) that contains the column under consideration and all the members which frame in at either end.

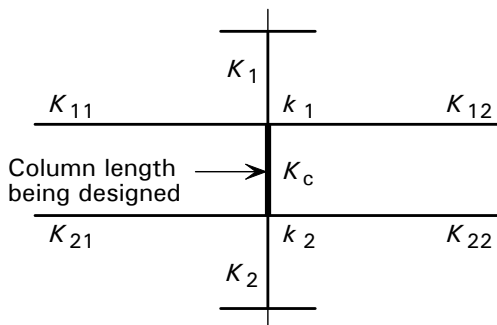


Figure 14.7 Limited frame model

Cl. 4.7.3
Annex E

Figure E.3

For the non-sway mode (i.e. where deflection of the top of the column relative to the bottom of the column is restricted) the analysis is based on the joint rotations at each end of the column and the elastic critical load. The solution to the stability condition is plotted directly as contours in terms of effective length ratios in Figure E.1 of BS 5950-1, which is reproduced here in part as Figure 14.8. The designer is required to calculate two distribution factors, k_1 and k_2 , at the upper and lower ends of the column respectively.

For columns in continuous multi-storey frames, k_1 and k_2 should be obtained from:

$$k = \frac{\text{Total stiffness of columns at the joint}}{\text{Total stiffness of all members at the joint}}$$

By using the values of k_1 and k_2 determined, a value for the effective length ratio of the column may be interpolated from the plotted contour lines of Figure 14.8.

For the sway mode, the analysis is based not only on the joint rotations at each end of the column and the elastic critical load but also the freedom of the top of the column to move relative to the bottom of the column. The solution to the stability condition is in Figure E.2 of BS 5950-1, which is reproduced here in part as Figure 14.9. The use of Figure 14.9 is identical to the use of Figure 14.8, as described above.

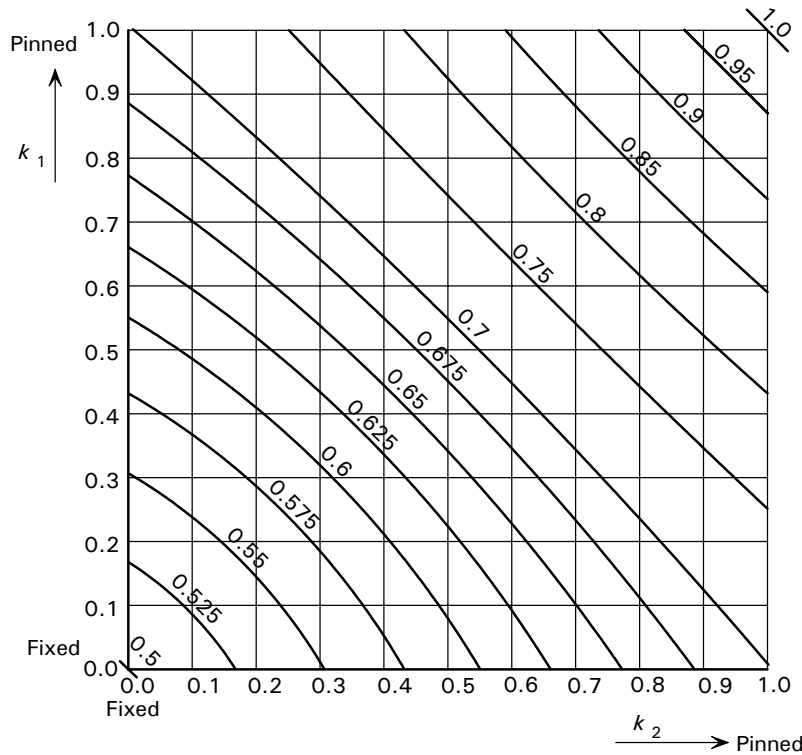


Figure E.1

Figure 14.8 Effective length ratio L_E/L for the non-sway buckling mode

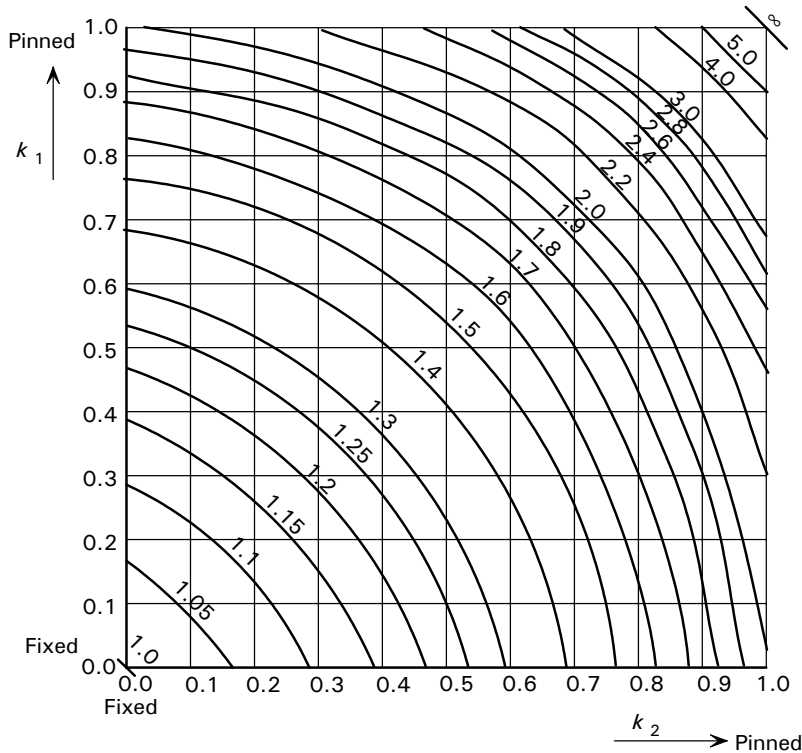


Figure 14.9 Effective length ratio L_E/L for the sway buckling mode

Note that the range of effective length ratios for the sway mode case is from 1.0 to infinity, compared to 0.5 to 1.0 for the non-sway mode.

The following points should be noted when using the charts in Figure 14.8 and Figure 14.9:

- Any member not present or not rigidly connected to the column under consideration should be given a K value (stiffness coefficient) of zero
- If the moment at either end of the column under consideration is more than 90% of its reduced plastic moment capacity M_r in the presence of axial load, the value of k_1 or k_2 as appropriate should be taken as 1.0.

Annex
E.2.1

Beam stiffness

In the analysis from which the charts were derived it was assumed that the ends of the beams remote from the column being designed were fully fixed. This is not always appropriate and guidance on modified beam stiffness values is provided in the Code.

For the most common case of a beam directly supporting a concrete or composite floor slab, and only carrying axial force due to sharing wind loads or notional horizontal loads between columns, K_b should be taken as I/L for the sway and non-sway mode.

Annex
E.2.2

where:

- I is the second moment of area for the section
- L is the length of the member

For other beams in buildings with concrete or composite floor slabs, where the only axial loads in the beams are due to sharing wind loads and notional horizontal loads between columns, K_b should be obtained from Table E.1 of BS 5950-1, reproduced here as Table 14.1.

Table 14.1 *Stiffness coefficients K_b for beams in buildings with floor slabs*

| Loading conditions of the beam | Beam stiffness coefficient K_b | |
|--|----------------------------------|-----------|
| | Non-sway mode | Sway Mode |
| Beams directly supporting concrete or composite floor or roof slab | 1.0 I/L | 1.0 I/L |
| Other beams with direct loads | 0.75 I/L | 1.0 I/L |
| Beams with end moments only | 0.5 I/L | 1.5 I/L |

Table E.1

For other frames (i.e. those without a concrete or composite floor slab) with a regular layout and where the beam fixity conditions are the same at the far end, K_b should be taken as:

Annex
E.4.1

- For non-sway frames (single curvature), $K_b = 0.5 I/L$
- For sway frames (double curvature), $K_b = 1.5 I/L$

Figure 14.10 and Figure 14.11 show single and double curvature bending in the critical buckling modes for non-sway and sway frames.

For beams with other end conditions, K_b should be obtained from Table E.2 of BS 5950-1, reproduced here as Table 14.2.

Table 14.2 *Stiffness coefficients K_b for beams in general*

| Rotational restraint at far end of beam | Beam stiffness coefficient K_b |
|---|-------------------------------------|
| Fixed at far end | 1.0 I/L |
| Pinned at far end | 0.75 I/L |
| Rotation as at near end (double curvature)* | 1.5 I/L |
| Rotation equal and opposite to that at near end (single curvature)* | 0.5 I/L |
| General case. Rotation θ_a at near end and θ_b at far end | $(1 + 0.5 \theta_b / \theta_a) / L$ |

Table E.2

* Figure 14.10 and Figure 14.11 show single and double curvature bending in the critical buckling modes for non-sway and sway frames.

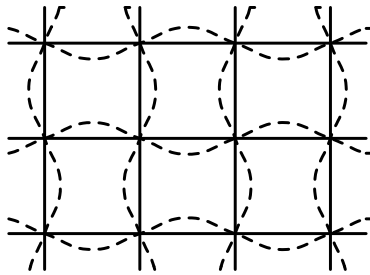


Figure 14.10 Critical buckling mode for non-sway frames

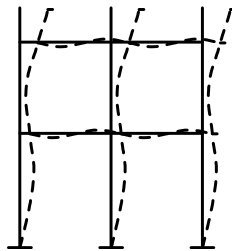


Figure 14.11 Critical buckling mode for sway frames

If the peak moment within a beam restraining the column under consideration is more than 90% of its reduced plastic moment capacity M_r in the presence of axial load, it should be considered pinned at that point and the beam stiffness taken as zero. However, if the point of peak moment only occurs at the far end of the beam, the maximum value of beam stiffness K_b should be taken as $0.75I/L$.

Annex
E.2.2
Annex
E.4.1

If plastic analysis has been used, the K_b factor for the beams should be taken as zero, unless the beams are designed to remain elastic, see Section 14.6.3.

Effect of axial force

Thus far it has been assumed that the beams only carry axial force due to sharing wind loads or notional horizontal loads between columns. However, if compressive loads exist in the beams, their effectiveness in restraining the column will be reduced. The Code allows the charts (Figures E.1 and E.2) to be used provided the effect of axial load in the beams is taken into account.

Annex
E.4.2

For non-sway frames, stability functions may be used to modify the stiffness coefficients or Table E.3 of BS 5950-1 may be used to obtain beam stiffness coefficients.

For sway frames, the in-plane effective length should be obtained using the elastic critical load factor λ_{cr} (see Section 14.6.5, below).

Column stiffness

In general, the stiffness coefficient K_c for adjacent columns should be taken as I/L . However, if the far end of the column is not rigidly connected, K_c should be taken as $0.75 I/L$.

Annex
E.2.4

If the peak moment within an adjacent column is more than 90% of its reduced plastic moment capacity M_r in the presence of axial load, it should be considered pinned at that point and the column stiffness taken as zero. However, if the point of peak moment only occurs at the far end of the column, the value of column stiffness K_b should be taken as $0.75I/L$.

Base stiffness

In calculating the distribution factor k_2 at the foot of a column, the base stiffness should be treated as a beam stiffness and not as a column stiffness, i.e. the base stiffness will only be part of the denominator of the equation given in Section 14.6.4.

Annex
E.2.3

The base stiffness of a column rigidly fixed to a suitable base should be taken as equal to the column stiffness for ultimate limit state checks using elastic global analysis. For this case, if there are no other members connected to the foot of the column k_2 will be 0.5.

Cl. 5.1.3.2

The base stiffness of a column nominally pinned to a suitable base should be taken as equal to 10% of the column stiffness for ultimate limit state checks using elastic global analysis. For this case, if there are no other members connected to the foot of the column k_2 will be 0.91.

Cl. 5.1.3.3

For nominal semi-rigid bases a base stiffness of up to 20% of the column stiffness may be assumed in elastic global analysis, provided that the foundation is designed for the moments and forces obtained from the analysis. For this case, if there are no other members connected to the foot of the column k_2 will be 0.83.

Partial sway bracing

For a structure where some resistance to side sway is provided by partial bracing or by the presence of infill panels, two additional charts are provided in Annex E. One (Figure E.4) is for the situation where the relative stiffness of the partial bracing k_p is 1 and the second (Figure E.5) is for $k_p = 2$.

Annex
E.3.1

The relative stiffness of the partial bracing k_p is given by:

$$k_p = \frac{h^2 \Sigma S_p}{80 E \Sigma K_c} \quad \text{but} \quad k_p \leq 2$$

Annex
E.3.3

where:

h is the storey height

ΣS_p is the sum of the horizontal spring stiffnesses (force per unit deflection) of the panels in that storey of the frame

E is the modulus of elasticity of steel

ΣK_c is the sum of the stiffness coefficients of the columns in that storey of the frame.

The spring stiffness S_p of the infill panel is given by:

$$S_p = \frac{0.6(h/b)tE_p}{(1+(h/b)^2)^2}$$

where:

b is the panel width

E_p is the modulus of elasticity of the panel material

t is the thickness of the panel material.

Having calculated k_p , the effective length of the column being designed may be derived by interpolating between values obtained from the charts for $k_p = 0$ (Figure E.2 of BS 5950-1 and Figure 14.9 here), $k_p = 1$ (Figure E.4) and $k_p = 2$ (Figure E.5).

14.6.5 Elastic critical load factor

The charts described in Sections 14.6.4 represent one method of determining the effective lengths of columns that are equivalent to carrying out a stability analysis for one segment of the frame and must be repeated for all segments. A more precise method is to determine the elastic critical load factor λ_{cr} for the frame, from which all effective length ratios may be determined.

The elastic critical load factor λ_{cr} is defined as the ratio by which each of the factored loads would have to be increased to cause elastic instability of the frame. If this factor is known then the axial load in every compression member at instability P_{cr} can be determined i.e. $P_{cr} = F_c \times \lambda_{cr}$.

The in-plane effective length L_E is given by:

$$L_E = \sqrt{\frac{\pi^2 EI}{\lambda_{cr} F_c}}$$

Annex E.6

where:

- E is the modulus of elasticity of steel
- I is the in-plane second moment of area of the column
- λ_{cr} is the elastic critical load factor of the whole frame in that plane
- F_c is the axial compression in the column under ULS loading

The sway mode elastic critical load factor may be determined by computer analysis or for continuous multi-storey frames by the deflection method described in Annex F of the Code, which states that:

$$\lambda_{cr} = \frac{1}{200\phi_{\max}}$$

Annex F.2

where:

- ϕ_{\max} is the maximum value of $(\delta_U - \delta_L)/h$ from any storey
- δ_U is the notional horizontal deflection at the top of the storey, see Figure 14.12
- δ_L is the notional horizontal deflection at the bottom of the storey, see Figure 14.12
- h is the storey height, see Figure 14.12.

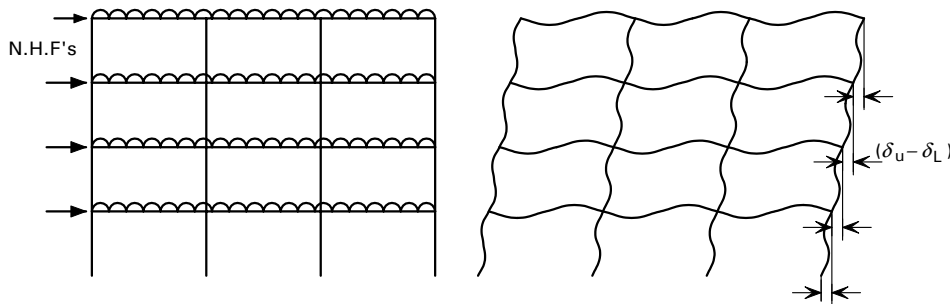


Figure 14.12 Sway frame deflections due to notional horizontal forces

14.7 Plastic design of continuous multi-storey frames

Whilst it would be relatively unusual to design a continuous multi-storey frame using plastic analysis, the code does give a number of rules for frames designed in this manner. Plastic design may only be used where the loading is essentially static and the frame is stabilised (e.g. braced) against sway out of plane.

Cl. 5.7

Detailed guidance on the plastic design continuous multi-storey frames is beyond the scope of this publication.

14.8 Summary of design procedure

1. Select member sizes for initial analysis based on experience.
2. Choose elastic or plastic design. The following steps are for elastic design.
3. Determine frame classification i.e. non-sway, sway-sensitive or independently braced.

Cl. 2.4.2.6

Cl. 5.1.4

Non-sway frames:

Cl. 5.6.3

- (a) Design to resist gravity loads (Load combination 1).
- (b) The non-sway mode effective length of the columns should be found from Annex E.
- (c) Pattern loading should be used to determine the most severe moments and forces.
- (d) Sub-frames may be used to reduce the number of load cases.
- (e) The frame should be checked for combined vertical and horizontal loads without pattern loading

Sway sensitive frames:

Cl. 5.6.4

- (a) Check in the non-sway mode, design to resist gravity loads (Load combination 1) as for independently braced frames without taking account of sway (without notional horizontal forces, but with full and pattern loading).
- (b) Check in the sway mode, design to resist gravity loads (Load combination 1) plus the notional horizontal forces without any pattern loading.

BS 5950-1

- (c) Check in the sway mode for combined vertical and horizontal loads (Load combinations 2 and 3) without pattern loading.
- (d) Allow for sway using the effective length method or the amplified sway method.

Independently braced frames:

- (a) Design to resist gravity loads (Load combination 1).
- (b) The non-sway mode effective length of the columns should be found from Annex E.
- (c) Full and pattern loading should be used to determine the most severe moments and forces.
- (d) Sub-frames may be used to reduce the number of load cases.
- (e) The bracing system must be designed to resist all the applied horizontal loads including the notional horizontal forces.

Cl. 5.6.2

15 CRANE GANTRY GIRDERS

15.1 Introduction

This Section describes only the additional design checks that are required for crane gantry girders, i.e. in addition to the checks that are required for a member subject to bending.

Crane gantry girders can be constructed from many types of members. Typical crane gantry girders are shown in Figure 15.1. This Section will assume that plate girders will be used, although, much of the design guidance is also applicable to other forms of crane gantry girders.

The design of crane gantry girders is one of the areas of steel design where there is a particular need for the exercise of engineering judgement. Special consideration is needed because of the fluctuating stresses that arise from the motion of the crane. BS 2573^[56] has codified the design of cranes and gives requirements to account for dynamic effects and fatigue. BS 5950-1 and BS 6399^[9] follow the same approach by referencing BS 2573.

Cl. 2.2.3

The increase in static vertical loads to allow for the impact dynamic effects, by applying the factors, can vary from about 10% for cranes with low usage in situations such as power stations, to 100% in cases where the crane is subject to heavy use and abuse, such as in foundries.

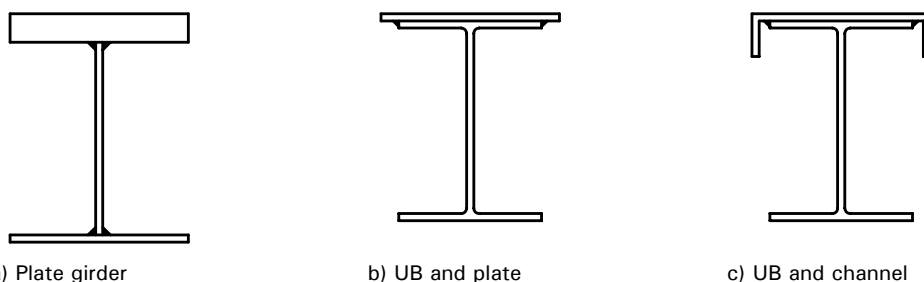


Figure 15.1 Typical crane gantry girders

15.2 Crane girder loading

15.2.1 General

The loads to be used for the design of crane gantry girders are not very clearly defined by current British Standards. This section discusses the provisions of BS 5950-1 and proposes a simplified loading to achieve a reasonably economical structure through reasonably simple design. BS 5950-1 makes reference to BS 2573-1:1983, *Rules for the design of cranes, Part 1, Specification for classification, stress calculations and design criteria for structures*. In particular, BS 5950-1 uses the BS 2573 crane classifications Q1, Q2, Q3 and Q4. The descriptive definitions given in BS 2573 are shown in Table 15.1 below.

Cl. 2.2.3

Table 15.1 *Crane classes*

| Class | Descriptive definition |
|-------|--|
| Q1 | Cranes that hoist the safe working load very rarely and, normally, light loads. |
| Q2 | Cranes that hoist the safe working load fairly frequently and, normally, moderate loads. |
| Q3 | Cranes that hoist the safe working load fairly frequently and, normally, heavy loads. |
| Q4 | Cranes that are normally loaded close to safe working load. |

Loading in BS 5950-1:2000

The principal Clauses on loading from cranes in BS 5950-1 are:

Clause 2.4.1.3, Overhead travelling cranes, states:

Cl. 2.4.1.3

“The γ_f factors given in Table 2 (Partial factors for loads γ_f) for vertical loads from overhead travelling cranes should be applied to the dynamic vertical wheel loads, i.e. the static vertical wheel loads increased by the appropriate allowance for dynamic effects.”

Clause 2.2.3, Loads from overhead travelling cranes, states:

Cl. 2.2.3

“For overhead travelling cranes, the vertical and horizontal dynamic loads and impact effects should be determined in accordance with BS 2573-1. The values for cranes of loading class Q3 and Q4 as defined in BS 2573-1 should be established in consultation with the crane manufacturer.”

Clause 4.11.2, Crabbing of trolley, states:

Cl. 4.11.2

“Gantry girders intended to carry cranes of loading class Q1 and Q2 as defined in BS 2573-1 need not be designed for the effect of crabbing action.”

For gantry girders intended to carry cranes of loading class Q3 and Q4 as defined in BS 2573-1, the design crabbing forces are defined in the clause (see Section 15.2.2).

Loading in BS 2573-1:1983

Vertical loads in BS 2573-1

BS 2573-1 increases the loads on the hook by an impact factor to allow for the dynamic effects, but does not apply any impact factor to the self-weight of the crane. However, it does reduce the allowable design stresses by a “duty factor” to account for effects not considered in the analysis. It is not practical to transfer the entire design procedure of BS 2573 to BS 5950 because BS 2573 is a permissible stress code whereas BS 5950 is a limit state code.

Horizontal loads in BS 2573-1

BS 2573-1 covers horizontal loads in Clause 3.1.5. This is divided into sub-clauses:

3.1.5.1, *Inertia forces*, gives no standard design force but makes it clear that it depends on the drive and brakes of each crane. (Commonly referred to as surge forces.)

3.1.5.2, *Skew loads due to travelling*, gives design loads, but BS 5950-1 defines the loads to be used in design of the girder in Clause 4.11.2. (Commonly referred to as crabbing forces.)

3.1.5.3, *Buffer loads*, gives no standard design force but makes it clear that it depends on each crane and gives some design guidance.

15.2.2 Design loads

From the above, it is clear that the best possible information should be sought on the design of the particular crane.

Traditionally, horizontal loads were taken as a transverse load of 10% of the static vertical reactions and a longitudinal load of 5% of the static vertical reactions, but not acting at the same time. These are the loads given in BS 449 which were included in BS 6399-1:1984, but do not appear in BS 6399-1:1996. One of the reasons for removing these factors is that they under-estimate the forces exerted by some modern cranes. There is anecdotal evidence of rare cases where the horizontal force can be as high as 20% to 30% of the vertical loads.

Vertical loading

There is concern about the use of BS 2573 impact factor alone for vertical load.

BS 2573 is a code for the design of cranes, not of crane gantry girders. As a crane moves along the rails, it will pass over irregularities such as joints in the rails. These will cause dynamic loads on the girder in addition to the static loads. This is a load case that must be considered. If a crane has a high self-weight but only a relatively light lifted load, design loads derived from BS 2573 might underestimate the vertical loads applied to the crane girder. Therefore, the designer should consider whether dynamic effects of the crane plus lifted load moving along the rail could give a worse vertical load than when the crane is stationary and lifting its load. Where the lifting case clearly gives the worst vertical load, loads from the crane moving need not be calculated. Where the lifting case does not clearly give the worst vertical load, loads from the crane moving should also be calculated as a separate vertical load case.

In the absence of better information, it is prudent to use the traditional dynamic factors (see Table 15.2) that have been used for decades to cover any cases that might be omitted by the use of BS 2573. Traditionally, crane gantry girder design (in BS 449) allowed for dynamic effects by using an additional 25% on static vertical reactions from the total crane self-weight plus lifted load. Where better information is impossible to obtain at the time of design, these traditional factors may be used in addition to the case using BS 2573 as a reasonable basis of design for any load cases that might be omitted by the use of the BS 2573 impact factor on the lifted load alone.

The vertical load cases recommended above can be summarised as follows:

Table 15.2 Load combinations

| Vertical load cases | Total wheel load on rail |
|--|---|
| BS 2573 impact factors (Crane stationary) | $F \times \gamma_f \times R_h + \gamma_f \times R_s$ |
| Crane moving with load | $1.25 \times \gamma_f \times R_h + 1.25 \times \gamma_f \times R_s$ |

where:

F is the impact factor from BS 2573-1

γ_f is the partial factor for loads from BS 5950-1

R_h is the unfactored vertical wheel reaction from the hook load

R_s is the unfactored vertical wheel reaction from the crane self weight

A gantry girder design example employing the above load combinations is provided in SCI publication P326^[6].

Horizontal loads

The horizontal loads due to surge or inertia forces are taken as; (1) a transverse load of 10% of the combined weight of the crab and the lifted load, (2) a longitudinal load of 5% of the static vertical reactions (i.e. from the weight of the crab, crane bridge and lifted load). These loads should not be taken as acting at the same time.

Skew loads due to travelling (Crabbing forces)

It has been found that with the longer spans across buildings and the lighter crane structures there is a tendency for the crane to twist rather than travel straight along the building. This crabbing action causes a horizontal couple (as shown in Figure 15.2) to be applied to the rails from the end carriage. The value of this crabbing force (unfactored) is given by:

$$F_R = \frac{L_c W_w}{40 a_w} \quad \text{but} \quad F_R \geq \frac{W_w}{20}$$

Cl. 4.11.2

where:

L_c and a_w are as shown on Figure 15.2

W_w is the largest factored load (including dynamic effects) on any wheel or bogie pivot.

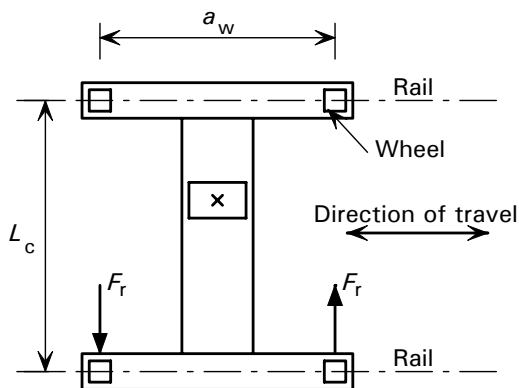


Figure 15.2 Crane crabbing forces

15.3 Lateral torsional buckling

Lateral torsional buckling must be considered in the design of the gantry girder unless a fully effective restraint is provided. For example by a rigid surge girder. The equivalent uniform moment factor m_{LT} for gantry girders should be taken as 1.0 for all cases. Provided the crane rails are not mounted on resilient (soft) pads, the crane load should be regarded as normal (i.e. not destabilizing). The buckling resistance moment M_b for gantry girders is calculated using the same method as described in Section 7.4.3. However, most gantry girders are asymmetric sections, therefore the equivalent slenderness λ_{LT} must be calculated using the expressions provided in Annex B.2.4 of the Code.

Cl. 4.11.3

Cl. 4.3.6.4

Annex
B.2.4

15.4 Web shear

As the crane moves along the girder, there are reversals in the direction as well as in the size of the shear stresses in the web. The result is that high stress reversals could be a potential source of fatigue and this should be considered in the design. The relevant British Standard for fatigue is BS 7608^[7].

15.5 Local compression under wheels

The local compressive stress in the web can be calculated by distributing the load over a length x_R given by:

Cl. 4.11.4

$$x_R = 2(H_R + T) \quad \text{but} \quad x_R \leq s_w$$

If the actual rail properties are known the following expression may be used.

$$x_R = K_R \left(\frac{I_f + I_R}{t} \right)^{1/3} \quad \text{but} \quad x_R \leq s_w$$

where:

H_R is the rail height

T is the top flange thickness

s_w is the minimum distance between the centres of adjacent wheels

$K_R = 3.25$, if the rail is mounted directly onto the flange

$= 4.0$, if resilient pads at least 5 mm thick are used between the rail and the flange

I_f is the second moment of area of the flange about its horizontal centroidal axis

I_R is the second moment of area of the crane rail about its horizontal centroidal axis

t is the web thickness

The stress on this length of web should be limited to the web design strength p_{yw} .

Local stresses beneath the crane rail depend on the degree of contact between the rail and the girder flange. Significant reductions in these stresses occur if a resilient pad is placed beneath the rail. This is accounted for by an increased value of K_R where a suitable pad is present.

15.6 Welding

The welds between the top of the web and the flange in crane girders are subject to high direct bearing stresses due to the concentration of the wheel loads on the top flange. When welding a gantry girder all welds should, if possible, be fully continuous. Welds between the top flange and the web should preferably be full penetration butt welds. This requirement is a precaution to reduce the likelihood of a fatigue failure. The weld should be capable of transferring the wheel loads over the length x_R , as calculated above.

Cl. 4.11.5

15.7 Deflection limits

Table 8 of BS 5950-1 (reproduced in Section 1.7 as Table 1.6) provides the following deflections limits for crane girders:

Cl. 2.5.2

- Vertical deflection limit = Span / 600
- Horizontal deflection limit = Span / 500

Table 8

The engineer should always check that the maximum deflection is not more than the crane can tolerate. This may be checked by consultation with the crane manufacturer, because the movement of the supporting structure may have a significant effect on the behaviour of the crane. It will be found that gantry girders on portal frame type structures will be more prone to movement problems than those on lattice girder type structures, due to the sway of the frame.

15.8 Summary of design procedure

These are the additional steps required specifically for crane gantry girders.

1. Determine the maximum vertical wheel load
2. Calculate the crabbing load
3. Determine the load due to surge
4. Calculate the factored loads due to the load combinations
5. Establish maximum moments and shears for each load combination
6. Choose a trial cross-section for the girder
7. Check the moment capacity, shear and interaction for the vertical loads
8. Check the moment capacity for the horizontal loads, which are usually assumed to be carried by the top plate only
9. Calculate the buckling resistance moment of the section
10. Check the section for the interaction of combined horizontal and vertical moments
11. Check the maximum girder deflection is within the limits for both vertical and horizontal movement.

Cl. 4.11.2

Cl. 2.4.1.3

Cl. 4.2.5

Cl. 4.2.5

Cl. 4.3.6

Cl. 4.11.3

Cl. 4.8

Table 8

16 REFERENCES

- 1 BRITISH STANDARDS INSTITUTION
 BS 5950 Structural use of steelwork in building
 BS 5950-1:2000 Code of practice for design – Rolled and welded sections
 BS 5950-2: 2001 Specification for materials, fabrication and erection: Rolled and welded sections
 BS 5950-3: 1990 Design in composite construction - Section 3.1: Code of practice for the design of simple and continuous composite beams
 BS 5950-4: 1994 Code of practice for design of composite slabs with profiled steel sheeting
 BS 5950-5: 1998 Code of practice for design of cold-formed thin gauge sections
 BS 5950-6: 1995 Code of practice for design of light gauge profiled steel sheeting
 BS 5950-7: 1992 Specification for materials and workmanship: cold formed sections
 BS 5950-8: 1990 Code of practice for fire resistant design
 BS 5950-9: 1994 Code of practice for stressed skin design
- 2 HEYWOOD, M.
 Guide to the major amendments in BS 5950-1:2000 (P304)
 The Steel Construction Institute, 2001
- 3 COUCHMAN, G. H.
 Design of semi-continuous braced frames (P183)
 The Steel Construction Institute, 1997
- 4 SALTER, P. R., COUCHMAN, G. H., ANDERSON, D.
 Wind Moment design of low rise frames (P263)
 The Steel Construction Institute, 1999
- 5 BUILDING RESEARCH ESTABLISHMENT
 BRE Digest 436, Part 1. Wind loading on buildings – Brief guidance for using BS 6399
 BRE, 1999
- 6 Steelwork design guide to BS 5950-1:2000
 Volume 2: Worked Examples (P326)
 The Steel Construction Institute, 2003
- 7 BRITISH STANDARDS INSTITUTION
 BS 7608: 1993 Code of practice for fatigue design and assessment of steel structures
- 8 The Building Regulations 2000 (SI 2000 No 2531)
 (Including Amendments 2001, 2001)
 The Stationery Office
- 9 BRITISH STANDARDS INSTITUTION
 BS 6399 Loading for Buildings
 BS 6399-1: 1996 Code of practice for dead and imposed loads
 BS 6399-2: 1997 Code of practice for wind load
 BS 6399-3: 1998 Code of practice for imposed roof loads

- 10 WYATT, T.A.
Design guide on the vibration of floors (P076)
The Steel Construction Institute, 1989
- 11 Advisory Desk Note No. AD253
Design considerations for the vibrations of floors Part 1
New Steel Construction, January 2002, Vol 10(1)
- 12 Advisory Desk Note No. AD254
Design considerations for the vibrations of floors Part 2
New Steel Construction, January 2002, Vol 10(1)
- 13 Advisory Desk Note No. AD256
Design considerations for the vibrations of floors Part 3
New Steel Construction, March 2002, Vol 10(2)
- 14 BRITISH STANDARDS INSTITUTION
EN1993-1 Eurocode 3 Design of steel structures. General rules and rules for buildings
Due to be published in 2004
- 15 MURRAY, T. M., ALLEN, D. E. and UNGAR, E. E.
Design guide 11: Floor vibration due to human activity
AISC, 1997
- 16 The prevention of corrosion on structural steelwork
Corus, 2001
- 17 BRITISH STANDARDS INSTITUTION
BS EN 10025: 1993 Hot rolled products of non-alloy structural steels. Technical delivery conditions (including amendment 1995)
- 18 BRITISH STANDARDS INSTITUTION
BS EN 10113 Hot rolled products in weldable fine grain structural steels
BS EN 10113-1: 1993 General delivery conditions. (Replaces BS 4360:1990)
- 19 BRITISH STANDARDS INSTITUTION
BS 4 Structural steel sections
BS 4-1: 1993 Specification for hot rolled sections
(Including amendment 2001)
- 20 BRITISH STANDARDS INSTITUTION
BS EN 10034: 1993 Structural steel I and H sections. Tolerances on shape and dimensions
(Replaces part of BS 4-1: 1980)
- 21 BRITISH STANDARDS INSTITUTION
BS EN 10024: 1995 Hot rolled taper flange I sections. Tolerances on shape and dimensions
- 22 BRITISH STANDARDS INSTITUTION
BS EN 10279:2000 Hot rolled steel channels. Tolerances on shape, dimension and mass
(Including amendment 1, amendment 2: 2000)
- 23 BRITISH STANDARDS INSTITUTION
BS EN 10056 Specification for structural steel equal and unequal angles
BS EN 10056-1: 1999 Dimensions (Replaces BS 4848-4: 1972)
BS EN 10056-2: 1999 Tolerances on shape and dimensions (Replaces BS 4848-4: 1972)

- 24 BRITISH STANDARDS INSTITUTION
 BS EN 10210 Hot finished structural hollow sections of non-alloy and fine grain structural steels
 BS EN 10210-1: 1994 Technical delivery requirements (Replaces BS 4360: 1990)
 BS EN 10210-2: 1997 Tolerances, dimensions and sectional properties. (Replaces BS 4848-2: 1991)
- 25 BRITISH STANDARDS INSTITUTION
 BS EN 10219 Cold-formed welded structural sections of non-alloy and fine grain steels
 BS EN 10219-1: 1997 Technical delivery requirements
 BS EN 10219-2: 1997 Tolerances, dimensions and sectional properties. (Replaces BS 6363: 1983)
- 26 Steelwork design guide to BS 5950-1:2000
 Volume 1: Section properties and member capacities. 6th Edition (P202)
 The Steel Construction Institute, 2001
- 27 Advisory Desk Note No. AD058
 Effective lengths of compression members - 1
 Steel Construction Today, April 1990, Vol 4(2)
- 28 Advisory Desk Note No. AD059
 Effective lengths of compression members - 2
 Steel Construction Today, April 1990, Vol 4(2)
- 29 Advisory Desk Note No. AD064
 Effective lengths – Portal frames
 Steel Construction Today, August 1990, Vol 4(4)
- 30 Advisory Desk Note No. AD069
 Effective lengths of compression members - 3
 Steel Construction Today, October 1990, Vol 4(5)
- 31 Advisory Desk Note No. AD070
 Effective lengths of compression members - 4
 Steel Construction Today, October 1990, Vol 4(5)
- 32 LAWSON, R. M.
 Design for openings in the webs of composite beams (P068)
 The Steel Construction Institute, 1989
- 33 KNOWLES, P. R.
 Design of castellated beams, for use with BS 5950 and BS 449 (P005)
 The Steel Construction Institute, 1985
- 34 WARD, J. K.
 Design of composite and non-composite cellular beams (P100)
 The Steel Construction Institute, 1990
- 35 Advisory Desk Note No. AD109
 BS 5950-1 m-factors for compression members with moments
 Steel Construction Today, May 1992, Vol 6(3)

- 36 Advisory Desk Note No. AD251
Equivalent uniform moment factor, m
New Steel Construction, September 2001, Vol 9(5)
- 37 Joints in Steel Construction: Simple Connections (P212)
The Steel Construction Institute and The British Constructional Steelwork Association Ltd, 2002
- 38 Joints in Steel Construction: Moment Connections (P207)
The Steel Construction Institute and The British Constructional Steelwork Association Ltd, 1995
- 39 Joints in Steel Construction: Composite Connections (P213)
The Steel Construction Institute and The British Constructional Steelwork Association Ltd, 1998
- 40 CRADDOCK, P.
Guide to site Welding (P161)
The Steel Construction Institute, 2002
- 41 Advisory Desk Note No. AD243
Splices within unrestrained lengths
New Steel Construction, November 2000, Vol 8(6)
- 42 Advisory Desk Note No. AD244
Second-order moments
New Steel Construction, November 2000, Vol 8 (6)
- 43 BRITISH STANDARDS INSTITUTION
BS 4190: 2001 ISO metric black hexagon bolts, screws and nuts - Specification
- 44 BRITISH STANDARDS INSTITUTION
BS 4395 Specification for high strength friction grip bolts and associated nuts and washers for structural engineering
BS 4395-1: 1969 General grade (including amendment 1, amendment 2: 1997)
BS 4395-2: 1969 Higher grade bolts and nuts and general grade washers (including amendment 1, amendment 2: 1976)
- 45 BRITISH STANDARDS INSTITUTION
BS 4604 Specification for the use of high strength friction grip bolts in structural steelwork. Metric series
BS 4604-1:1970 General grade (including amendment 1, amendment 2, and amendment 3: 1982)
BS 4604-2:1970 Higher grade (parallel shank) (including amendment 1, amendment 2: 1972)
- 46 PACKER, J. A., WARDENIER, J., KUROBANE, Y., DUTTA, D. and YEAMANS, N.
Design guide for rectangular hollow section (RHS) joints under predominantly static loading
CIDECT, 1992
- 47 WARDENIER, J., KUROBANE, Y., PACKER, J. A., DUTTA, D. and YEAMANS, N.
Design guide for circular hollow section (CHS) joints under predominantly static loading
CIDECT, 1991

- 48 Design of SHS welded Joints (TD 338)
Corus Tubes, 2001
- 49 CD-ROM Disc for design of welded joints (TD 340)
Corus Tubes, 2001
- 50 Advisory Desk Note No. AD252
Axially loaded columns – Base plate design – Effective area method
New Steel Construction, November 2001, Vol 9(6)
- 51 DAVIES, J. M. and BROWN, B. A.
Plastic design to BS 5950 (P026)
The Steel Construction Institute, 1996
- 52 KING, C.
In-plane stability of portal frames to BS 5950-1:2000 (P292)
The Steel Construction Institute, 2001
- 53 Design Guide to BS 5950
Volume 4: Essential data for designers (P070)
The Steel Construction Institute, 1991
- 54 Advisory Desk Note No. AD090
Deflection limits for pitched roof portal frames
Steel Construction Today, July 1991, Vol 5(4)
- 55 BRITISH STANDARDS INSTITUTION
BS 5400 Steel, concrete and composite bridges
BS 5400-1: 1988 General statement
BS 5400-2: 1978 Specification for loads
BS 5400-3:2000 Code of practice for design of steel bridges
- 56 BRITISH STANDARDS INSTITUTION
BS 2573 Rules for the design of cranes
BS 2573-1:1983 Specification for classification, stress calculations and design criteria
for structures

APPENDIX A: Plastically designed portal frame (Worked Example)

A.1 Frame dimensions and loading

The frame shown in Figure A.1 will be used to demonstrate the procedure for the initial sizing and checking of the members of a plastically designed portal frame. Figure A.1 gives the dimensions and Table A.1 gives the loading on this frame.

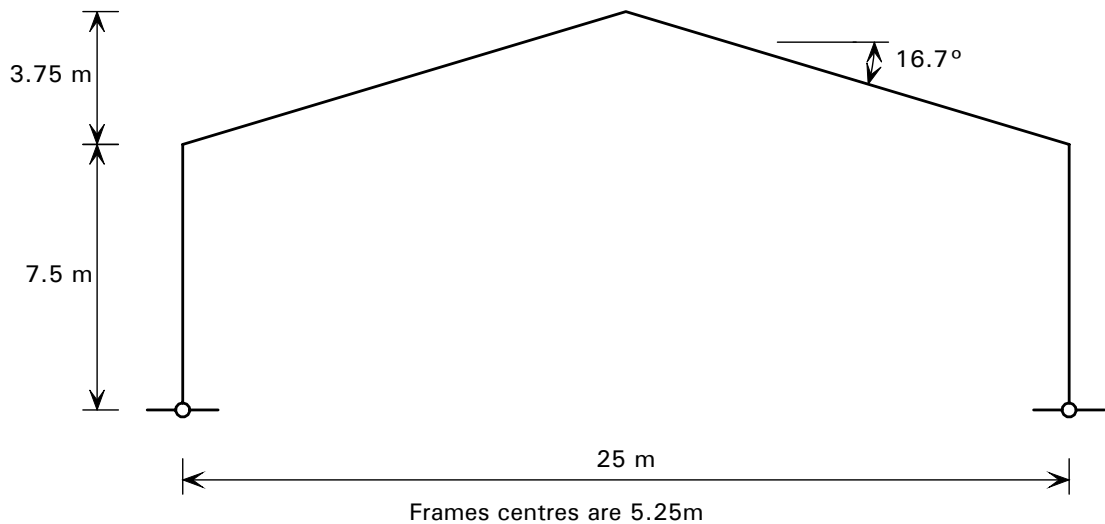


Figure A.1 Dimensions of frame

Table A.1 Loads on frame

| Load type | Unfactored load kN/m ² | Load factor | Factored load kN/m ² | Total Factored load on the frame kN |
|-----------|--------------------------------------|-------------|------------------------------------|---|
| Imposed | 0.75 | 1.6 | 1.2 | 158 |
| Dead | 0.43 | 1.4 | 0.6 | 079 |
| | | | Total | 237 |

The total factored load per metre = $237 / 25 = 9.48$ kN/m

A.2 Selecting initial member sizes

Engineers may use their experience or other methods to determine initial member sizes. The graphs in Figures A.13, A.14 and A.15 in Section A.4.3 will be used for this example. In order to use the graphs four values are required:

- (a) Span/height to eaves = $25/7.5$ = 3.33
- (b) Rise/span = $3.75/25$ = 0.15
- (c) wL (total load on frame) = 9.48×25 = 237 kN
- (d) wL^2 = 9.48×25^2 = 5925 kNm

From the graphs the following is obtained (details on how to use the graphs are provided in Section A.4.3):

- Horizontal force at feet of frame (from 0, Graph 1)
= $0.21 \times 237 = 49.8 \text{ kN}$
- Required moment capacity of rafter (from 0, Graph 2)
= $0.0305 \times 5925 = 181 \text{ kNm}$
- Required moment capacity of column (from 0, Graph 3)
= $0.059 \times 5925 = 350 \text{ kNm}$

Assuming steel grade S275 for the rafter and column, the following trial sections are selected (N.B. these are first trials and may not be adequate):

- Rafter $406 \times 140 \times 39 \text{ kg UB}$ Class1 Plastic $M_{cx} = 199 \text{ kNm}$
- Column $457 \times 152 \times 60 \text{ kg UB}$ Class1 Plastic $M_{cx} = 354 \text{ kNm}$

Both these sections are Class 1 plastic sections when classified using Table 11 of BS 5950-1.

A.3 Design checks

A.3.1 In-plane frame stability

The next stage is to check the overall stability of the frame. The main reason for this is that the only way to correct insufficient stability is to change the main member sizes. If any of the other checks are not satisfied then additional bracing can usually be added without altering member sizes. Figure A.2 and Figure A.3 show the bending moment diagrams for the frame for vertical loading and horizontal loading, respectively.

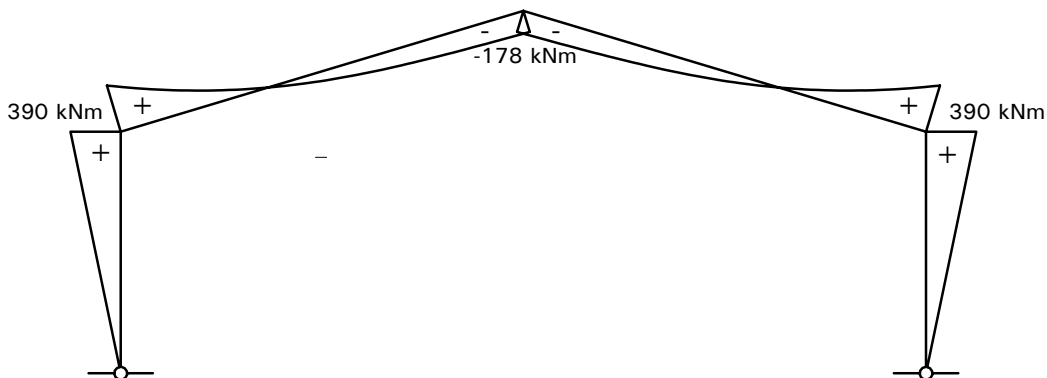


Figure A.2 Bending moment diagram for vertical loading

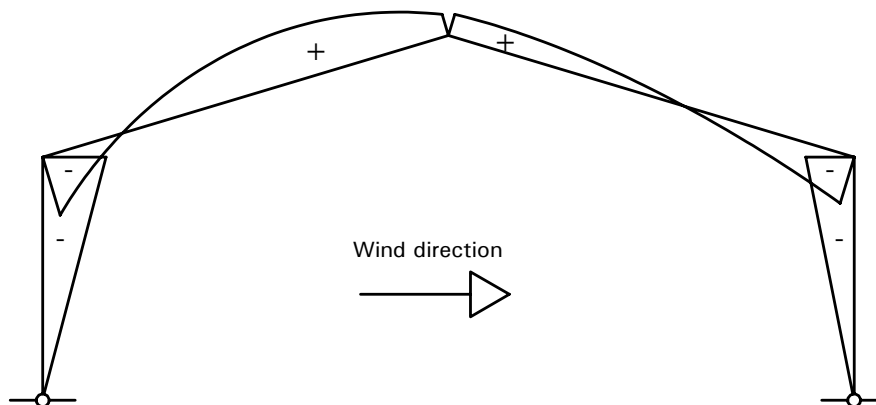


Figure A.3 Bending moment diagram for wind loading

As stated in Clause 5.5.4.1 of BS 5950-1, the in-plane stability may be checked using one of the following methods:

- Sway check method (including the snap-through check)
- Amplified moments methods
- Second-order analysis.

For plastic design the plastic load factor (λ_p) must not be less than the required load factor (λ_r).

The sway check method will be used for this example. Therefore, the requirements of BS 5950-1, Clause 5.5.4.2 need to be satisfied. Figure A.4 shows the haunch dimensions required for the sway check equation.

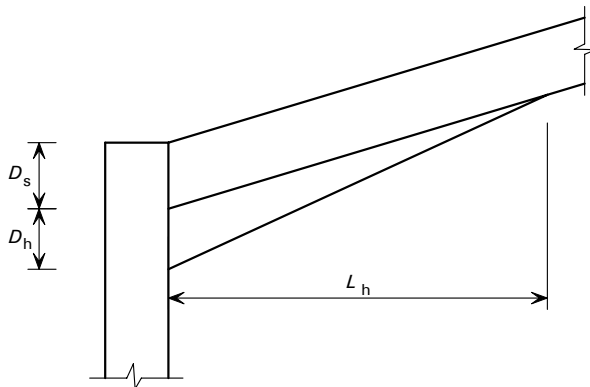


Figure A.4 Haunch dimensions

General (Cl. 5.5.4.2.1)

$$L \leq 5h \quad L = 25 \text{ m}, \quad 5h = 5 \times 7.5 = 37.5 \text{ m, therefore OK.}$$

$$h_r \leq 0.25 \times L \quad h_r = 3.75 \text{ m} \quad 0.25 \times L = 0.25 \times 25 = 6.25 \text{ m, therefore OK.}$$

The frame dimensions are within the limits allowed for the sway check method.

For gravity loads (Cl. 5.5.4.2.2)

The simplified formula (see Section 12.3) may be used for this example:

$$\frac{L_b}{D} \leq \frac{44L}{\Omega h} \left(\frac{\rho}{4 + \rho L_r / L} \right) \left(\frac{275}{p_{yr}} \right) \quad \text{then} \quad \lambda_r = 1.0$$

where:

- D is the cross-sectional depth of the rafter, 398 mm
- D_h is the additional depth of the haunch below the rafter, (say) 370 mm
- D_s is the depth of the rafter allowing for slope = $398/\cos 16.7^\circ = 416$ mm
- h is the mean column height = 7.5 m
- I_c is the in-plane second moment of area of the columns = 25500 cm⁴
- I_r is the in-plane second moment of area of the rafter = 12500 cm⁴
- L is the span of the bay = 25 m
- L_b is the effective span of the bay

$$= L - \left(\frac{2D_h}{D_s + D_h} \right) L_h = 25 - \left(\frac{2 \times 370}{416 + 370} \right) 2.5 = 22.6 \text{ m}$$

L_h is the length of the haunch, (say) span/10 = 25/10 = 2.5 m

L_r is the total developed length of the rafter, $25/\cos 16.7^\circ = 26.1 \text{ m}$

p_{yr} is the design strength of the rafters in $\text{N/mm}^2 = 275 \text{ N/mm}^2$

W_r is the total factored vertical load on the rafters of the bay = 237 kN

W_o is the maximum load that can be placed on the rafter treated as a fixed ended beam of span L (i.e. $M_{\max} = W_o L/16 = S_x p_y$, therefore $W_o = 16 S_x p_y/L$)

$$W_o = 16 \times 724 \times 10^3 \times 275 \times 10^{-3} / (25 \times 10^3) = 127 \text{ kN}$$

$$\rho = \left(\frac{2I_c}{I_r} \right) \left(\frac{L}{h} \right) = \left(\frac{2 \times 25500}{12500} \right) \left(\frac{25}{7.5} \right) = 13.6$$

$$\Omega = W_r/W_o = 237/127 = 1.87$$

Therefore equating the equations above gives:

$$\frac{L_b}{D} \leq \frac{44 \times 25}{1.87 \times 7.5} \left(\frac{13.6}{4 + 13.6 \times 26.1/25} \right) \left(\frac{275}{275} \right) = 58.6$$

$$\frac{L_b}{D} = \frac{22.6}{0.398} = 56.8 < 58.6$$

Therefore, λ_r may be taken as 1.0 and the frame is stable under this load combination.

Computer software shows that, for this load case, λ_p is greater than 1.0. Therefore the requirement that λ_p must not be less than λ_r is satisfied.

For horizontal loads (Cl. 5.5.4.2.3)

The required collapse factor is given by:

$$\lambda_r = \frac{\lambda_{sc}}{\lambda_{sc} - 1}$$

$$\lambda_{sc} = \frac{220 DL}{\Omega h L_b} \left(\frac{\rho}{4 + \rho L_r / L} \right) \left(\frac{275}{p_{yr}} \right)$$

$$\lambda_{sc} = \frac{220 \times 398 \times 25}{1.87 \times 7.5 \times 22.6 \times 1000} \left(\frac{13.6}{4 + 13.6 \times 26.1/25} \right) \left(\frac{275}{275} \right) = 5.16$$

$$\lambda_r = \frac{\lambda_{sc}}{\lambda_{sc} - 1} = \frac{5.16}{5.16 - 1} = 1.24$$

Therefore, for this load case, λ_p must not be less than 1.24. The actual value of λ_p would depend on the magnitude of the applied horizontal loads but generally λ_p would be greater than λ_r . In this example it is assumed that the gravity load case is critical.

Snap-through (Cl. 5.5.4.3)

The frame in this example only has one bay therefore the snap-through check is not required.

A.3.2 Out-of-plane frame stability

Clause 5.5.1 of BS 5950-1 refers to Cl. 2.4.2.5 for out-of-plane frame stability for portal frames.

The out-of-plane stability of the frame should be ensured by making the frame effectively non-sway out-of-plane. This will usually imply bracing of some sort, although the use of very stiff portal frame action is not uncommon.

Guidance on the classification of frames as either non-sway or sway-sensitive is given in Section 1.6.3.

A.3.3 In-plane member stability

For a single bay portal frame, a separate check on the in-plane member stability is not required because it is satisfied by checking the in-plane stability of the frame (as given in Section A.3.1).

A.3.4 Out-of-plane member stability

Table A.2 gives a summary of the design process for out-of-plane member stability.

Table A.2 Summary of out-of-plane member stability checks

| Restraints along the length | Plastic hinge location | Member type | BS 5950-1:2000 clause | Notes |
|--|--|---------------------------------|--|--|
| Unrestrained length | No plastic hinge present | Uniform member | 4.8.3.3 and 5.3.3 | For 4.8.3.3 segment length need not be less than L_m |
| | | Non-uniform member | | |
| | Plastic hinge present | Uniform member | 5.3.2 and 5.3.3 | A varying moment can be allowed for. |
| Non-uniform member | | 5.3.2 and 5.3.3 | A varying moment can be allowed for. The minimum value of r_y and maximum value of x within the length should be used. | |
| Length restrained along the tension flange | Simplified method for use with or without plastic hinges | Uniform and non-uniform members | 5.3.4 | All conditions in 5.3.4 need to be satisfied |
| | No plastic hinge present | Uniform member | G.2.1 (or G.3.3.1) | Conditions a) and b) in 5.3.4 need to be satisfied |
| | | Non-uniform member | G.2.2 (or G.3.3.2) | |
| | Plastic hinge present | Uniform member | G.3.3.1 | |
| Non-uniform member | | G.3.3.2 | | |

Clause 5.3.1 of BS 5950-1 states that where the rigid plastic collapse load factor λ_p is greater than the required value λ_r , then the resistance of the member to out-of-plane buckling may be checked using the moments and forces corresponding to λ_r rather than to λ_p . In this example it is assumed that the gravity load case is critical, λ_r is taken as 1.0 and the members may be checked for the actual forces and moments due to the design loads.

Assume that the plastic hinges occur at locations consistent with the preliminary method of design (see Section A.4.1), i.e. at the bottom of the haunch in the column and approximately

1.5 m from the apex in the rafter. These assumptions would have to be checked for a real design situation.

Column stability

The plastic hinge at the bottom of the haunch must be provided with torsional restraint (i.e. both flanges should have lateral restraint). The simplest and most common way to do this is with stays back to a substantial side rail as shown in Section 12.5.2, Figure 12.4.

A further lateral restraint to the compression flange will be required at a distance L_m from the hinge location (Cl. 5.3.3). Conservatively, the distance L_m must not exceed L_u given by:

$$L_u = \frac{38r_y}{\left[\frac{f_c}{130} + \left(\frac{x}{36} \right)^2 \left(\frac{p_y}{275} \right)^2 \right]^{1/2}}$$

The trial section (457 × 152 × 60 kg UB S275) has the following properties:

$$r_y = 3.23 \text{ cm}$$

$$x = 37.5$$

$$A = 76.2 \text{ cm}^2$$

f_c is the compressive stress in the column (in N/mm²) due to axial force

Therefore, $f_c = \text{total load}/(2 \times \text{Area}) = 237 \times 10^3 / (2 \times 76.2 \times 10^2) = 15.6 \text{ N/mm}^2$

$$L_u = \frac{38 \times 3.23 \times 10}{\left[\frac{15.6}{130} + \left(\frac{37.5}{36} \right)^2 \left(\frac{275}{275} \right)^2 \right]^{1/2}} = 1118 \text{ mm} = 1.12 \text{ m}$$

Provided that the conditions of BS 5950-1 Clause 5.3.3(b) are satisfied, the limiting distance L_u can be increased by allowing for the shape of the bending moment diagram, between the torsional restraint at the plastic hinge and the adjacent lateral restraint to the compression flange, by the use of the factor ϕ . Try restraints at a distance half way up the column at 3.5 m away from the plastic hinge position (see Figure A.5 and Figure A.6).

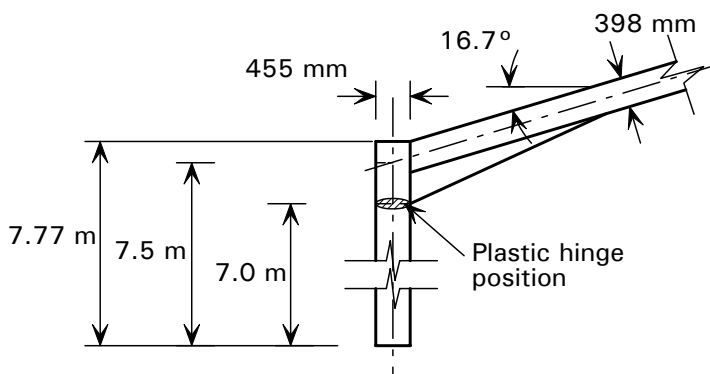


Figure A.5 Dimensions to haunch

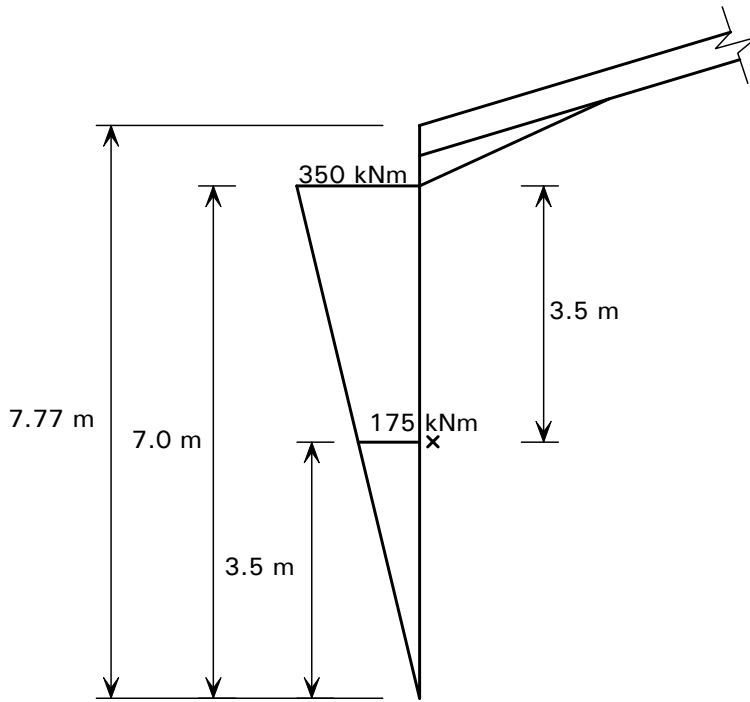


Figure A.6 Bending moment diagram and trial restraint positions for portal column

The moment at the plastic hinge equals 350 kNm. The moment at a point half way up the column equals $350/2 = 175$ kNm.

Applying Clause 5.3.3 (b) of BS 5950-1 gives:

$$\beta = 175/350 = 0.50$$

$$\beta_u = 0.44 + x/270 - f_c/200 = 0.44 + 37.5/270 - 15.6/200 = 0.50$$

β is less than 1 and equal to β_u therefore $\phi=1$

$$L_m = \phi L_u = 1 \times 1.12 = 1.12 \text{ m}$$

The trial restraint position is therefore too far away from the plastic hinge.

If we try a restraint closer to the hinge position we would find that, in this case, the ratio between the end moments gives a value of ϕ equal to unity (because $\beta > \beta_u$) and therefore no increase in the value of L_m can be obtained by this method in this case. Therefore assume that L_m cannot be increased beyond 1.12 m by using this method for this section.

Taking account of restraint on one flange

Consider the length between the plastic hinge and the next lateral restraint to the compression flange, taking advantage of intermediate lateral restraints on the tension flange provided by the side rails. The length between the side rails must first be checked to ensure that it would be adequate if the restraints were on the compression flange. This may be done by using the normal rules for elastic design or, conservatively, they should be spaced no further apart than the distance L_m given above. If it is assumed that the side rails will be spaced at 1 m intervals (i.e. $< L_m$) this requirement is satisfied.

Clause 5.3.4 of BS 5950-1 gives the limiting spacing L_s of restraints for S275 steel as:

$$L_s = \frac{620 r_y}{K_1 [72 - (100/x)^2]^{0.5}} = \frac{620 \times 3.23 \times 10}{1 [72 - (100/37.5)^2]^{0.5}} \times 10^{-3} = 2.49 \text{ m}$$

Therefore, a suitable restraint system could be as shown in Figure A.7.

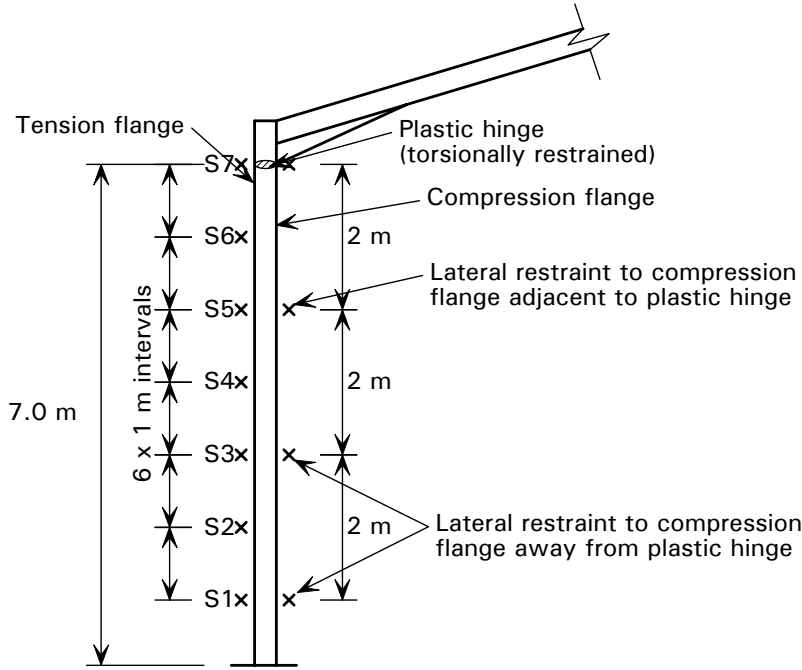


Figure A.7 Possible restraint positions for portal column

It is likely that Annex G of BS 5950-1 would allow the spacing of the restraints to be increased. Alternatively, the length between the lateral restraint adjacent to the plastic hinge (at S5) and the next lateral restraint (at S3) could be checked (at say 3 m i.e. S2) by elastic methods (see Figure A.8).

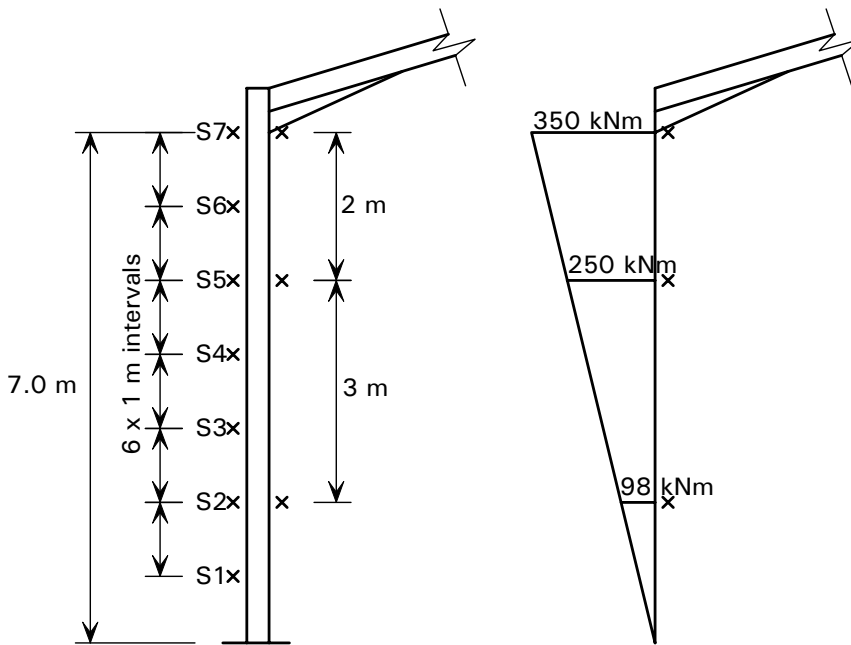


Figure A.8 Alternative restraint positions and bending moments for portal column

From Axial & Bending capacity tables^[26], for a $457 \times 152 \times 60$ UB with $F/P_z < 0.285$ ($F/P_z = F/Ap_y = 237 \times 0.5/2100 = 0.06$) and an effective length of 3 m; $P_{cy} = 1180$ kN and $M_b = 226$ kNm.

Using the simple formulae in Clause 4.8.3.3.1 of BS 5950-1,

$$\beta = 98/250 = 0.4, \text{ from Table 18 of BS 5950-1 } m_{LT} = 0.76$$

$$\frac{F_c}{P_{cy}} + \frac{m_{LT} M_{LT}}{M_b} + \frac{m_y M_y}{p_y Z_y} \leq 1 \quad \frac{119}{1180} + \frac{0.76 \times 250}{226} + \frac{0}{p_y Z_y} = 0.94 < 1$$

The 3 m length between the lateral restraints (S5 and S2) is adequate. The remaining length with a lower moment is also adequate by inspection.

The use of Annex G would almost certainly obviate the need for the lower restraint (at S2) to the compression flange.

Rafter stability

The rafter stability needs to be checked in the eaves region and in the apex region. The eaves region is usually critical for the vertical load case. The apex region of the rafter is more critical under the horizontal load case, where uplift has occurred and the bottom flange of the rafter is in compression.

For vertical loading the greater part of the rafter length will be subject to a sagging moment, with the top flange in compression. The top flange of the rafter will be restrained at intervals by the purlins and, in the elastic region away from the plastic hinge, the rafter can be checked by the normal rules of Clause 4.3 of BS 5950-1 (see Section 7.4). This is normally a check that is easily satisfied. The plastic hinge near the apex must be torsionally restrained, which is usually achieved using fly braces (stays) to the purlins.

Eaves region - Haunch stability

For vertical loading, the bottom flange of the haunch will be in compression and will require restraints at intervals. In this example, no plastic hinges are formed at the rafter ends of the eaves haunch, therefore the stability of the haunch can be checked in accordance with the requirements of BS 5950-1 Cl. 5.3.4 (conservative approach) or Cl. G.2. If the approach of Cl. 5.3.4 is adopted, the conditions stated in the clause must be satisfied (see Section 12.5.2). Both approaches are demonstrated here.

Haunch stability - Clause 5.3.4. approach

For S275 the simplified method gives the minimum distance between lateral restraints as:

$$L_s = \frac{620 r_y}{K_1 [72 - (100/x)^2]^{0.5}}$$

where:

r_y is the minor axis radius of gyration of the un-haunched section

x is the torsional index of the un-haunched section

For the trial rafter (406 × 140 × 39 kg UB):

$$r_y = 2.87 \text{ cm}$$

$$x = 47.5$$

$$D_h / D_s = 370 / 416 = 0.9, \text{ therefore take } K_1 = 1.25$$

$$L_s = \frac{620 r_y}{K_1 [72 - (100/x)^2]^{0.5}} = \frac{620 \times 2.87 \times 10}{1.25 [72 - (100/47.5)^2]^{0.5}} = 1732 \text{ mm} = 1.73 \text{ m}$$

Assuming that the haunch length is 10% of the span (i.e. 2.5m long) L_s is less than the length of the haunch. A restraint would be required at about 1.7 m from the column face. Conservatively a further restraint (or virtual restraint) is also required at 3.4 m from the column face. Clause 5.5.5 of BS 5950-1 allows the point of contraflexure to be treated as a virtual lateral restraint to the bottom flange provided the purlins and their connections to the rafter are capable of providing torsional restraint to the top flange of the rafter. This torsional restraint can be achieved, provided the criteria given in Clause 5.5.5 are satisfied.

Haunch stability - Annex G.2 approach

The calculation procedure for Annex G.2 is shown below. The requirements of Annex G.1.4 for intermediate lateral restraints to the top flange also need to be satisfied.

Figure A.9 shows the haunch details and restraint locations. Annex G.2.2 of BS 5950-1 states that the following expression needs to be satisfied at points within the segment length. This example will consider points 1 to 5, see Figure A.9.

$$M_{xi} \leq M_{bi} (1 - F_c/P_c)$$

where:

M_{xi} is the major axis moment at point i

M_{bi} is the buckling resistance moment at point i, using an equivalent slenderness λ_{TB} from G.2.4.2

F_c is the longitudinal compression on the reference axis (rafter axial compression)

P_c is compression resistance based on the section properties of the minimum section within the segment and a slenderness λ_{TC} from G.2.3.

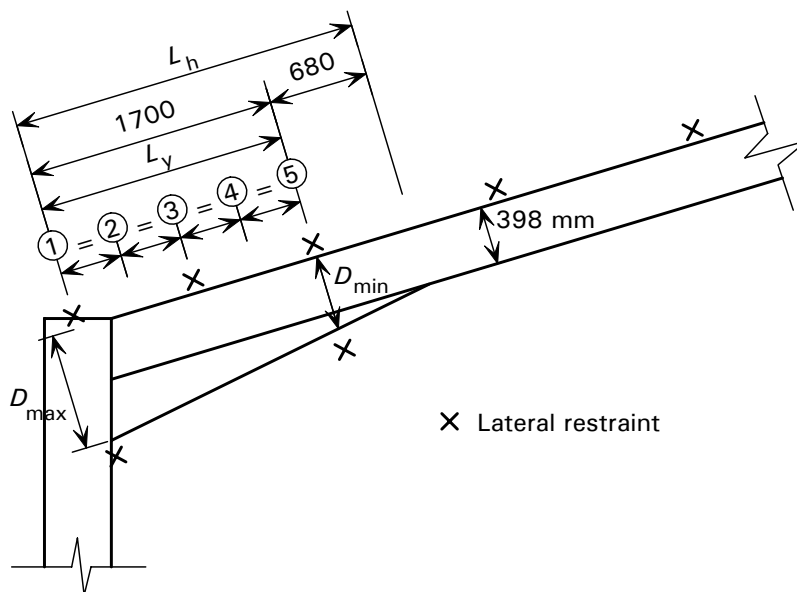


Figure A.9 *Haunch details*

Table A.3 gives section property data for the haunched rafter at cross-sections 1 to 5. The section properties are calculated normal to the axis of the rafter. The elastic modulus for the compression flange Z_{xc} and the plastic modulus have been calculated including all three flanges but ignoring the root radii.

Table A.3 Section properties for cross-sections 1 to 5

| Cross-section | 1 | 2 | 3 | 4 | 5 |
|-----------------------------|------|------|------|------|------|
| Position (mm) | 0 | 425 | 850 | 1275 | 1700 |
| Depth (mm) | 753 | 690 | 626 | 563 | 499 |
| Z_{xc} (cm ³) | 1475 | 1326 | 1196 | 1089 | 1009 |
| S_x (cm ³) | 1778 | 1572 | 1389 | 1231 | 1085 |

Calculation of M_{bi}

For tapered segments the equivalent slenderness λ_{TB} is given by:

$$\lambda_{TB} = c n_t v_t \lambda \quad (\text{G.2.4.2})$$

For tapered segments the taper factor c is given by:

$$c = 1 + \frac{3}{x-9} \left(\frac{D_{\max}}{D_{\min}} - 1 \right)^{2/3} \quad (\text{G.2.5})$$

where:

$$D_{\max} = 753 \text{ mm}$$

$$D_{\min} = 499 \text{ mm}$$

$$x = 47.5 \text{ (conservatively taken as the torsional index of the rafter section, Ref. 26)}$$

This gives,

$$c = 1 + \frac{3}{47.5-9} \left(\frac{753}{499} - 1 \right)^{2/3} = 1.05$$

The slenderness correction factor η_t is given by:

$$n_t = \left[\frac{1}{12} (R_1 + 3R_2 + 4R_3 + 3R_4 + R_5 + 2(R_S - R_E)) \right]^{0.5} \quad (\text{G.4.3})$$

where:

$$R_i = \frac{M_x}{p_y Z_{xc}} \text{ (see Table A.4)}$$

$$p_y = 275 \text{ N/mm}^2$$

$$R_S = \text{Maximum } R_i = 0.93$$

$$R_E = \text{Maximum } R_i \text{ or } R_5 = 0.93$$

Table A.4 Values of R_i

| Cross-section | 1 | 2 | 3 | 4 | 5 |
|-----------------------------|------|------|------|------|------|
| M_x (kNm) | 378 | 335 | 295 | 256 | 219 |
| Z_{xc} (cm ³) | 1475 | 1326 | 1196 | 1089 | 1009 |
| R_i | 0.93 | 0.92 | 0.90 | 0.85 | 0.79 |

Therefore,

$$n_t = \left[\frac{1}{12} (0.93 + 3 \times 0.92 + 4 \times 0.90 + 3 \times 0.85 + 0.79 + 2(0.93 - 0.93)) \right]^{0.5} = 0.941$$

For a three-flanged haunch, v_t is given by:

$$v_t = \left[\frac{4a/h_s}{1 + (2a/h_s)^2 + 0.05(\lambda/x)^2 + 0.02(\lambda/x_h)^2} \right]^{0.5} \quad (\text{G.2.4.2})$$

where:

$$x_h = x = 47.5$$

$$h_s \approx D_{\min} - T = 499 - 8.6 = 490.4 \text{ mm}$$

$$a = D/2 + a' \text{ (see Figure A.10)}$$

$$a' = \text{say } 60 \text{ mm}$$

$$a = 398/2 + 60 = 259 \text{ mm}$$

$$\lambda = L_y / r_y$$

$$r_y = (I_y / A_g)^{0.5} \text{ (Minor axis radius of gyration for the minimum depth cross-section)}$$

$$I_y = 614 \text{ cm}^3 \text{ (Minor axis second moment of area for the minimum depth cross-section)}$$

$$A_g = 66.9 \text{ cm}^2 \text{ (Gross area for the minimum depth cross-section)}$$

$$r_y = (614 / 66.9)^{0.5} = 3.03 \text{ cm}$$

$$\lambda = 1700 / (3.03 \times 10) = 56.1$$

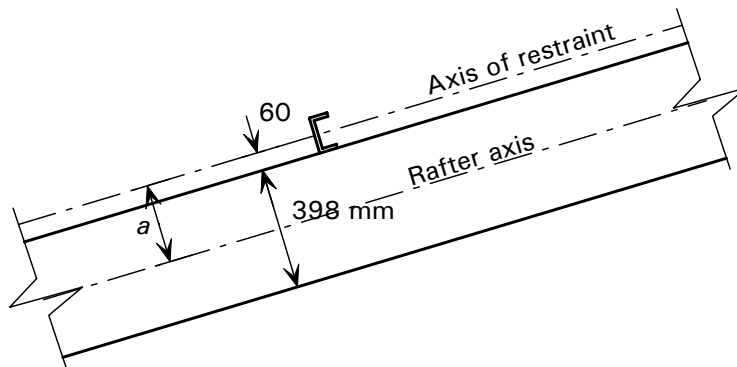


Figure A.10 Restraint axis

Therefore,

$$v_t = \left[\frac{4 \times 259 / 490.4}{1 + (2 \times 259 / 490.4)^2 + 0.05 (56.1 / 47.5)^2 + 0.02 (56.1 / 47.5)^2} \right]^{0.5}$$

$$v_t = \left[\frac{2.11}{1 + 1.12 + 0.07 + 0.03} \right]^{0.5} = 0.975$$

From these values λ_{TB} can be calculated,

$$\lambda_{TB} = c n_t v_t \lambda = 1.05 \times 0.941 \times 0.975 \times 56.1 = 54.0$$

The section is Class 1 plastic therefore M_{bi} is given by:

$$M_{bi} = p_b S_x \quad (\text{Cl. 4.3.6.4})$$

where:

$$p_b = 227 \text{ N/mm}^2 \text{ (from Table 16 of BS 5950-1, using } \lambda_{LT} = 54 \text{ and } p_y = 275 \text{ N/mm}^2)$$

Table A.5 Values of M_{bi}

| Cross-section | 1 | 2 | 3 | 4 | 5 |
|--------------------------|------|------|------|------|------|
| S_x (cm ³) | 1778 | 1572 | 1389 | 1231 | 1085 |
| M_b (kNm) | 404 | 357 | 315 | 279 | 246 |

Calculation of P_c

The slenderness λ_{TC} to be used for compression is given by:

$$\lambda_{TC} = y \lambda \quad (\text{G.2.3})$$

where:

$$y = \left[\frac{1 + (2a/h_s)^2}{1 + (2a/h_s)^2 + 0.05(\lambda/x)^2} \right]^{0.5} \quad (\text{G.2.3})$$

$$y = \left[\frac{1 + (2 \times 259 / 490.4)^2}{1 + (2 \times 259 / 490.4)^2 + 0.05(56.1 / 47.5)^2} \right]^{0.5}$$

$$y = \left[\frac{1 + 1.12}{1 + 1.12 + 0.07} \right]^{0.5} = 0.984$$

$$\lambda_{TC} = 0.984 \times 56.1 = 55.2$$

For a Class 1 plastic section, the compression resistance is given by:

$$P_C = A_g p_c \quad (\text{Cl. 4.7.4})$$

where:

$$A_g = 66.9 \text{ cm}^2 \text{ (the gross area for the minimum section)}$$

$$p_c = 228 \text{ N/mm}^2 \text{ (from Table 24 (curve b) of BS 5950-1, using } \lambda_{TC} = 55.2 \text{ and } p_y = 275 \text{ N/mm}^2)$$

Therefore,

$$P_C = 66.9 \times 228 \times 10^{-1} = 1525 \text{ kN}$$

Check the following expression at cross-sections 1 to 5 (see Table A.6),

$$M_{xi} \leq M_{bi} (1 - F_c / P_c) \text{ i.e. } M_{xi} / (M_{bi} (1 - F_c / P_c)) \leq 1$$

From the frame analysis, the axial load in the rafter F_c is 80 kN.

Table A.6 Buckling check results at each cross-section

| Cross-section | 1 | 2 | 3 | 4 | 5 |
|-------------------------------------|-------|-------|-------|-------|-------|
| M_x (kNm) | 378 | 335 | 295 | 256 | 219 |
| M_b (kNm) | 404 | 357 | 315 | 279 | 246 |
| $1 - (F_c / P_c)$ | 0.948 | 0.948 | 0.948 | 0.948 | 0.948 |
| $M_b (1 - (F_c / P_c))$ | 383 | 338 | 299 | 265 | 233 |
| $\frac{M_x}{M_b (1 - (F_c / P_c))}$ | 0.99 | 0.99 | 0.99 | 0.97 | 0.94 |

Therefore, the first segment of the eaves haunch is stable using Annex G.2 with a restraint position 1.7 m from the end of the column.

Note:

Commercial software packages may apply BS 5950-1 Annex G.3 rather than Annex G.2. For segments adjacent to a plastic hinge, Annex G.3 may be used. For segments not adjacent to a plastic hinge, either Annex G.2 or G.3 may be used. In some situations Annex G.3 can give more economical solutions than Annex G.2.

Haunch stability - Annex G.3 approach

The calculation procedure for Annex G.3 is shown below for comparative purposes. The requirements of Annex G.1.4 for intermediate lateral restraints to the top flange also need to be satisfied.

The same restraint positions as shown in Figure A.9 are adopted. Annex G.3.3 of BS 5950-1 states that the segment length L_y should not exceed the limiting spacing L_s . For a haunched or tapered member, the limiting spacing is given by:

$$L_s = L_k / (c \times n_t) \quad (\text{G.3.3.2})$$

where:

$$c = 1.05 \text{ (from previous calculations)}$$

$$n_t = 0.941 \text{ (from previous calculations)}$$

L_k is the limiting length

The limiting length L_k is given by:

$$L_k = \frac{(5.4 + 600 p_y / E) r_y x}{(5.4 x^2 p_y / E - 1)^{0.5}} \quad (\text{G.3.3.3})$$

$$L_k = \frac{(5.4 + 600 \times 275 / 205000) 30.3 \times 47.5}{(5.4 \times 47.5^2 \times 275 / 205000 - 1)^{0.5}} = \frac{8930.4}{3.917} = 2280 \text{ mm}$$

Therefore,

$$L_s = 2280 / (1.05 \times 0.941) = 2308 \text{ mm} \quad (\text{G.3.3.2})$$

and,

$$L_y = 1700 \text{ mm} < 2308 \text{ mm}$$

Therefore, the first segment of the eaves haunch is stable using Annex G.3 with a restraint position 1.7 m from the end of the column.

Unless there is a stay at purlin P4 (see Figure A.11) the second segment along the rafter will be from purlin P3 to the point of contraflexure, a distance of approximately 3.3 m. Therefore, it is likely that a stay will be needed at purlin P4.

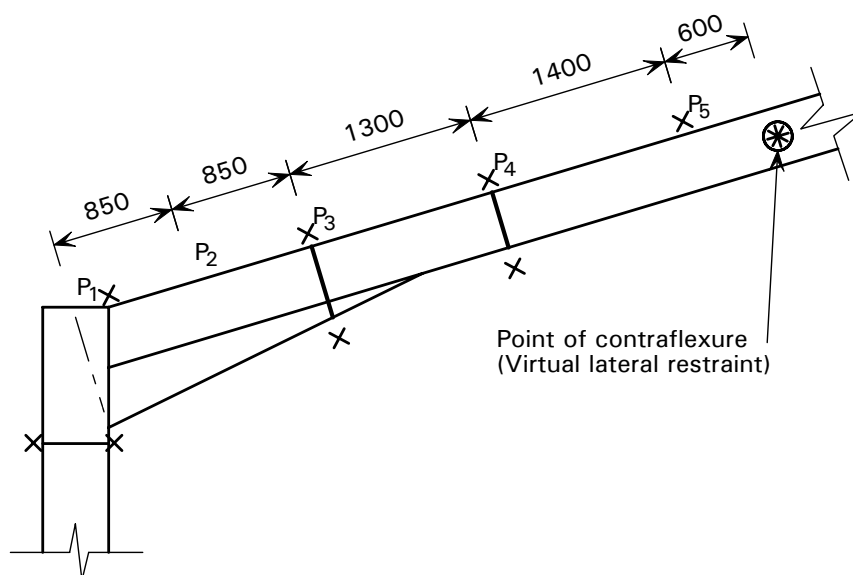


Figure A.11 Rafter restraints in the eaves haunch region

Apex region

For the gravity load case, a plastic hinge forms near the apex. From analysis it can be shown that the hinge forms at approximately 1.6 m from the apex i.e. at the second purlin from the apex. This hinge must be torsionally restrained by providing lateral restraints to both flanges of the rafter (Clause 5.3.2), which is usually achieved using fly braces (stays) from the purlins to the bottom flange.

For the lateral load case, the bottom flange at the apex will be in compression (due to reversal) and is likely to require restraints at intervals. Figure A.3 shows the bending moment diagram for horizontal loading. The top flange is laterally restrained by the purlins. To ensure out-of-plane stability, the required position of a lateral restraint to the bottom (compression) flange must be determined. The wind can also blow in the opposite direction and therefore any restraints should be arranged symmetrically about the apex.

In this example it is assumed that the gravity load case is critical, i.e. the plastic collapse factor λ_p for the gravity load case is lower than the plastic collapse factor for the lateral load case. As shown in Figure A.3, the maximum moment in the rafter for the lateral load case is at the third purlin from the apex. A plastic hinge is unlikely to form here because the lateral load case is not critical and the moments are not sufficient to form a hinge. Therefore, the rafter should be checked elastically for combined compression and bending between points of lateral restraint. Annex G or Clause 5.3.4 of BS 5950-1 may be used, if necessary additional lateral restraints to the bottom flange should be added.

Restraint summary

Figure A.12 shows the restraints required to the column and the rafter for both the vertical and the lateral load cases.

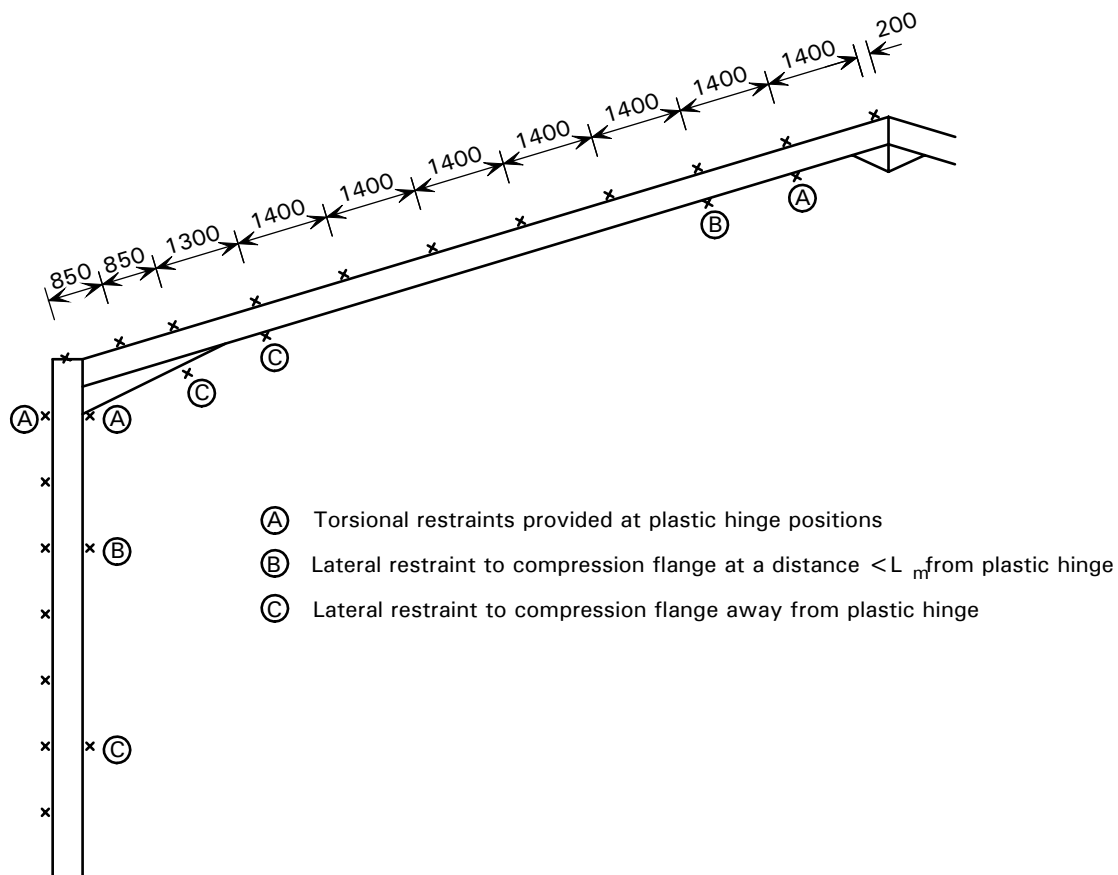


Figure A.12 Final positions of restraints for portal column and rafter

A.4 Graphs for initial portal frame member selection

In order to speed the initial selection of members, three graphs have been produced, to enable simple pin based frames to be sized quickly.

A.4.1 Assumptions

These graphs have been prepared making the following assumptions:

- Plastic hinges are formed in the column at the bottom of the haunch and in the rafter near the apex; the exact position being determined by the frame geometry.
- The depth of the rafter is approximately span/55 and the depth of the haunch below the eaves intersection is 1.5 times rafter depth.
- The haunch length is 10% of the span of the frame, a limit generally regarded as providing a balance between economy and stability.
- The moment in the rafter at the top of the haunch is $0.87M_p$, i.e. it is assumed that the haunch area remains elastic.
- The calculations assume that the sections exactly provide the calculated values of M_p and that there are no stability problems. Clearly, these conditions may not be met and it is the designer's responsibility to ensure that the chosen sections are fully checked for all aspects of behaviour.

A.4.2 Scope of graphs

The graphs cover the range of span/height to eaves between 1 and 10 and rise/span between 0 and 0.2 (where 0 is a flat roof). Interpolation is permissible but extrapolation of the graphs is not. The three graphs give the following:

- The horizontal force at the feet of the frame as a proportion of the total factored load (wL)
- The value of the moment capacity required in the rafters as a portion of the load times span (wL^2)
- The value of the moment capacity required in the columns as a portion of the load times span (wL^2).

where:

L is the span of the frame

w is the total factored load per metre span

The charts are non-dimensional and may be used with any consistent set of units.

A.4.3 Method of using the graphs

1. Determine the ratio span/height to eaves
2. Determine the ratio rise/span
3. Calculate wL (total load) and wL^2
4. From the charts look up the values:
 - a. (0) Graph 1: Horizontal force at foot of frame / wL .
 - b. (0) Graph 2: M_p required in the rafter / wL^2 .
 - c. (0) Graph 3: M_p required in the column / wL^2 .

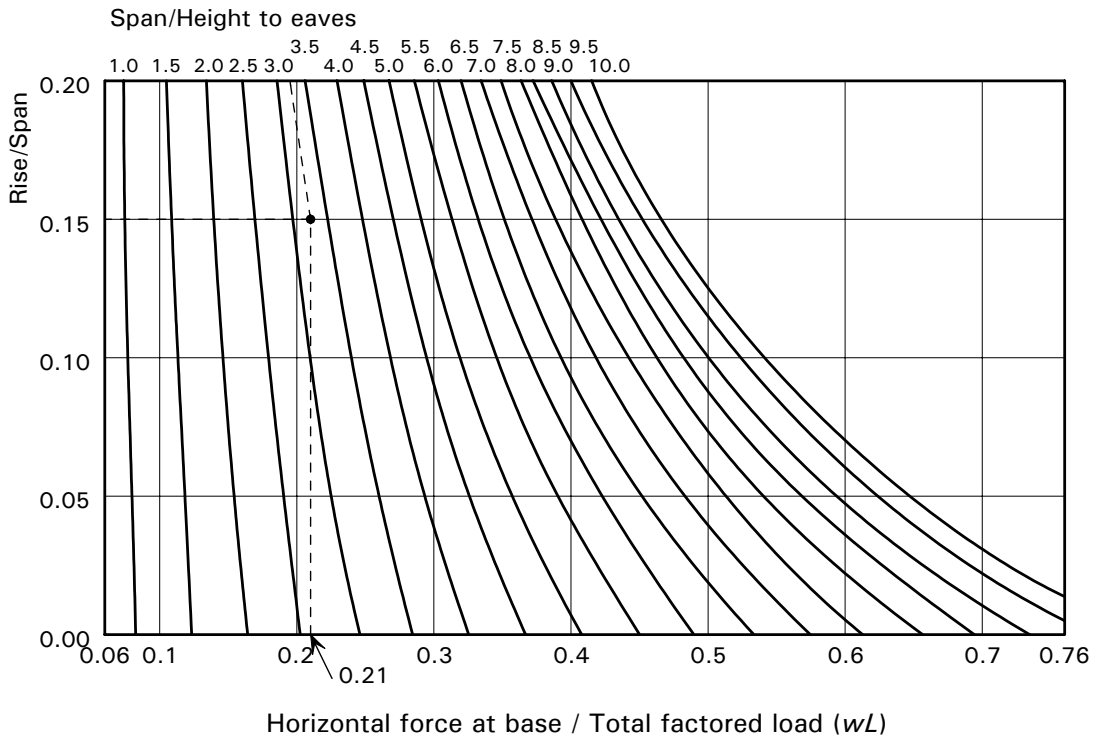


Figure A.13 Graph 1: Horizontal force at base

[Discuss me ...](#)

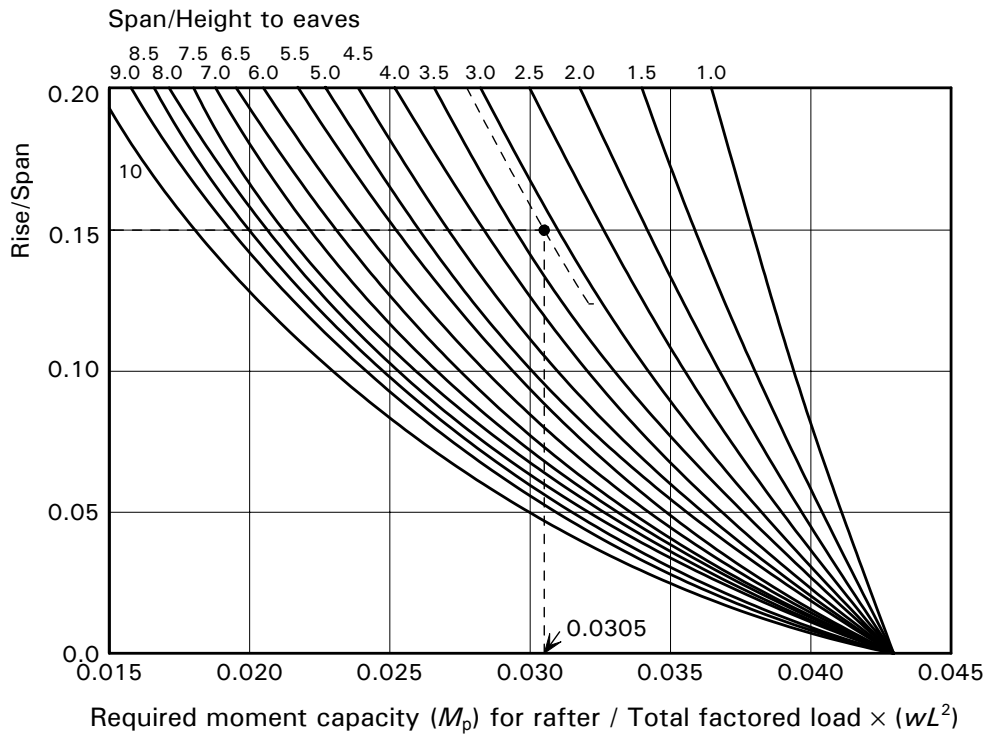


Figure A.14 Graph 2: Moment capacity required for the rafter

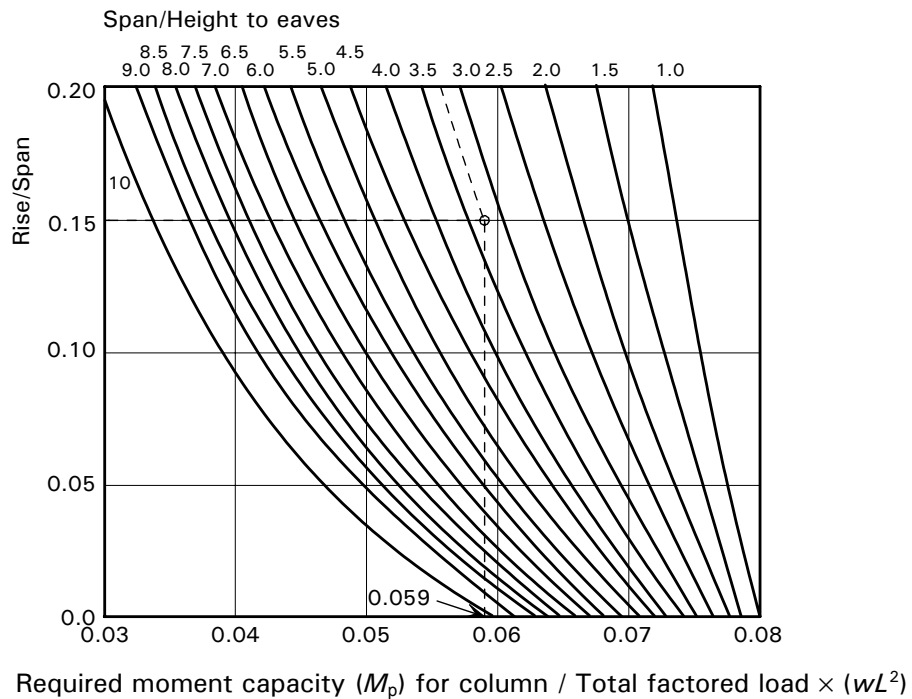


Figure A.15 Graph 3: Moment capacity required for the column

[Discuss me ...](#)

