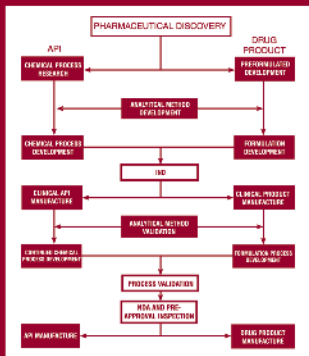


# Pharmaceutical Process Validation

An International Third Edition, Revised and Expanded



edited by  
Robert A. Nash  
Alfred H. Wachter

Previous edition: *Pharmaceutical Process Validation: Second Edition, Revised and Expanded* (I. R. Berry, R. A. Nash, eds.), 1993.

### **Library of Congress Cataloging-in-Publication Data**

A catalog record for this book is available from the Library of Congress.

**ISBN: 0-8247-0838-5**

This book is printed on acid-free paper.

### **Headquarters**

Marcel Dekker, Inc.  
270 Madison Avenue, New York, NY 10016  
tel: 212-696-9000; fax: 212-685-4540

### **Eastern Hemisphere Distribution**

Marcel Dekker AG  
Hutgasse 4, Postfach 812, CH-4001 Basel, Switzerland  
tel: 41-61-260-6300; fax: 41-61-260-6333

### **World Wide Web**

<http://www.dekker.com>

The publisher offers discounts on this book when ordered in bulk quantities. For more information, write to Special Sales/Professional Marketing at the headquarters address above.

**Copyright 2003 by Marcel Dekker, Inc. All Rights Reserved.**

Neither this book nor any part may be reproduced or transmitted in any form or by any means, electronic or mechanical, including photocopying, microfilming, and recording, or by any information storage and retrieval system, without permission in writing from the publisher.

Current printing (last digit):

10 9 8 7 6 5 4 3 2 1

**PRINTED IN THE UNITED STATES OF AMERICA**

# DRUGS AND THE PHARMACEUTICAL SCIENCES

## Executive Editor

**James Swarbrick**

*PharmaceuTech, Inc  
Fayetteville, North Carolina*

## Advisory Board

Larry L. Augsburger University of Maryland Baltimore, Maryland	David E. Nichols Purdue University West Lafayette, Indiana
--	--

Douwe D. Breimer Gorlaeus Laboratories Leiden, The Netherlands	Stephen G. Schulman University of Florida Gainesville, Florida
--	--

Trevor M. Jones The Association of the British Pharmaceutical Industry London, United Kingdom	Jerome P. Skelly Alexandria, Virginia
--	--

Hans E. Junginger Leiden/Amsterdam Center for Drug Research Leiden, The Netherlands	Felix Theeuwes Alza Corporation Palo Alto, California
--	---

Vincent H. L. Lee University of Southern California Los Angeles, California	Geoffrey T. Tucker University of Sheffield Royal Hallamshire Hospital Sheffield, United Kingdom
---	--

Peter G. Welling  
Institut de Recherche Jouveinal  
Fresnes, France

# DRUGS AND THE PHARMACEUTICAL SCIENCES

A Series of Textbooks and Monographs

1. Pharmacokinetics, *Milo Gibaldi and Donald Perrier*
2. Good Manufacturing Practices for Pharmaceuticals: A Plan for Total Quality Control, *Sidney H. Willig, Murray M. Tuckerman, and William S. Hitchings IV*
3. Microencapsulation, *edited by J. R. Nixon*
4. Drug Metabolism. Chemical and Biochemical Aspects, *Bernard Testa and Peter Jenner*
5. New Drugs: Discovery and Development, *edited by Alan A. Rubin*
6. Sustained and Controlled Release Drug Delivery Systems, *edited by Joseph R. Robinson*
7. Modern Pharmaceutics, *edited by Gilbert S. Banker and Christopher T. Rhodes*
8. Prescription Drugs in Short Supply: Case Histories, *Michael A. Schwartz*
9. Activated Charcoal: Antidotal and Other Medical Uses, *David O. Cooney*
10. Concepts in Drug Metabolism (in two parts), *edited by Peter Jenner and Bernard Testa*
11. Pharmaceutical Analysis: Modern Methods (in two parts), *edited by James W. Munson*
12. Techniques of Solubilization of Drugs, *edited by Samuel H. Yalkowsky*
13. Orphan Drugs, *edited by Fred E. Karch*
14. Novel Drug Delivery Systems: Fundamentals, Developmental Concepts, Biomedical Assessments, *Yie W. Chien*
15. Pharmacokinetics: Second Edition, Revised and Expanded, *Milo Gibaldi and Donald Perrier*
16. Good Manufacturing Practices for Pharmaceuticals: A Plan for Total Quality Control, Second Edition, Revised and Expanded, *Sidney H. Willig, Murray M. Tuckerman, and William S. Hitchings IV*
17. Formulation of Veterinary Dosage Forms, *edited by Jack Blodinger*
18. Dermatological Formulations. Percutaneous Absorption, *Brian W. Barry*
19. The Clinical Research Process in the Pharmaceutical Industry, *edited by Gary M. Matoren*
20. Microencapsulation and Related Drug Processes, *Patrick B. Deasy*
21. Drugs and Nutrients: The Interactive Effects, *edited by Daphne A. Roe and T. Colin Campbell*
22. Biotechnology of Industrial Antibiotics, *Erick J. Vandamme*

- 23 *Pharmaceutical Process Validation*, edited by *Bernard T Loftus and Robert A Nash*
- 24 *Anticancer and Interferon Agents Synthesis and Properties*, edited by *Raphael M Ottenbrite and George B Butler*
- 25 *Pharmaceutical Statistics Practical and Clinical Applications*, *Sanford Bolton*
- 26 *Drug Dynamics for Analytical, Clinical, and Biological Chemists*, *Benjamin J Gudzinowicz, Burrows T Younkin, Jr., and Michael J Gudzinowicz*
- 27 *Modern Analysis of Antibiotics*, edited by *Adjoran Aszalos*
- 28 *Solubility and Related Properties*, *Kenneth C James*
- 29 *Controlled Drug Delivery Fundamentals and Applications*, Second Edition, Revised and Expanded, edited by *Joseph R Robinson and Vincent H Lee*
- 30 *New Drug Approval Process Clinical and Regulatory Management*, edited by *Richard A Guarino*
- 31 *Transdermal Controlled Systemic Medications*, edited by *Yie W Chien*
- 32 *Drug Delivery Devices Fundamentals and Applications*, edited by *Praveen Tyle*
- 33 *Pharmacokinetics Regulatory • Industrial • Academic Perspectives*, edited by *Peter G Welling and Francis L S Tse*
- 34 *Clinical Drug Trials and Tribulations*, edited by *Allen E Cato*
- 35 *Transdermal Drug Delivery Developmental Issues and Research Initiatives*, edited by *Jonathan Hadgraft and Richard H Guy*
- 36 *Aqueous Polymeric Coatings for Pharmaceutical Dosage Forms*, edited by *James W McGinity*
- 37 *Pharmaceutical Pelletization Technology*, edited by *Isaac Ghebre-Sellassie*
- 38 *Good Laboratory Practice Regulations*, edited by *Allen F Hirsch*
- 39 *Nasal Systemic Drug Delivery*, *Yie W Chien, Kenneth S E Su, and Shyi-Feu Chang*
- 40 *Modern Pharmaceutics Second Edition, Revised and Expanded*, edited by *Gilbert S Banker and Christopher T Rhodes*
- 41 *Specialized Drug Delivery Systems Manufacturing and Production Technology*, edited by *Praveen Tyle*
- 42 *Topical Drug Delivery Formulations*, edited by *David W Osborne and Anton H Amann*
- 43 *Drug Stability Principles and Practices*, *Jens T Carstensen*
- 44 *Pharmaceutical Statistics Practical and Clinical Applications*, Second Edition, Revised and Expanded, *Sanford Bolton*
- 45 *Biodegradable Polymers as Drug Delivery Systems*, edited by *Mark Chasin and Robert Langer*
- 46 *Preclinical Drug Disposition A Laboratory Handbook*, *Francis L S Tse and James J Jaffe*
- 47 *HPLC in the Pharmaceutical Industry*, edited by *Godwin W Fong and Stanley K Lam*
- 48 *Pharmaceutical Bioequivalence*, edited by *Peter G Welling, Francis L S Tse, and Shrikant V Dinghe*

49. Pharmaceutical Dissolution Testing, *Umesh V. Banakar*
50. Novel Drug Delivery Systems: Second Edition, Revised and Expanded, *Yie W. Chien*
51. Managing the Clinical Drug Development Process, *David M. Cocchetto and Ronald V. Nardi*
52. Good Manufacturing Practices for Pharmaceuticals: A Plan for Total Quality Control, Third Edition, *edited by Sidney H. Willig and James R. Stoker*
53. Prodrugs: Topical and Ocular Drug Delivery, *edited by Kenneth B. Sloan*
54. Pharmaceutical Inhalation Aerosol Technology, *edited by Anthony J. Hickey*
55. Radiopharmaceuticals: Chemistry and Pharmacology, *edited by Adrian D. Nunn*
56. New Drug Approval Process: Second Edition, Revised and Expanded, *edited by Richard A. Guarino*
57. Pharmaceutical Process Validation: Second Edition, Revised and Expanded, *edited by Ira R. Berry and Robert A. Nash*
58. Ophthalmic Drug Delivery Systems, *edited by Ashim K. Mitra*
59. Pharmaceutical Skin Penetration Enhancement, *edited by Kenneth A. Walters and Jonathan Hadgraft*
60. Colonic Drug Absorption and Metabolism, *edited by Peter R. Bieck*
61. Pharmaceutical Particulate Carriers: Therapeutic Applications, *edited by Alain Rolland*
62. Drug Permeation Enhancement: Theory and Applications, *edited by Dean S. Hsieh*
63. Glycopeptide Antibiotics, *edited by Ramakrishnan Nagarajan*
64. Achieving Sterility in Medical and Pharmaceutical Products, *Nigel A. Halls*
65. Multiparticulate Oral Drug Delivery, *edited by Isaac Ghebre-Sellassie*
66. Colloidal Drug Delivery Systems, *edited by Jörg Kreuter*
67. Pharmacokinetics: Regulatory • Industrial • Academic Perspectives, Second Edition, *edited by Peter G. Welling and Francis L. S. Tse*
68. Drug Stability: Principles and Practices, Second Edition, Revised and Expanded, *Jens T. Carstensen*
69. Good Laboratory Practice Regulations: Second Edition, Revised and Expanded, *edited by Sandy Weinberg*
70. Physical Characterization of Pharmaceutical Solids, *edited by Harry G. Brittain*
71. Pharmaceutical Powder Compaction Technology, *edited by Göran Alderborn and Christer Nyström*
72. Modern Pharmaceutics. Third Edition, Revised and Expanded, *edited by Gilbert S. Banker and Christopher T. Rhodes*
73. Microencapsulation. Methods and Industrial Applications, *edited by Simon Benita*
74. Oral Mucosal Drug Delivery, *edited by Michael J. Rathbone*
75. Clinical Research in Pharmaceutical Development, *edited by Barry Bleidt and Michael Montagne*

- 76 The Drug Development Process Increasing Efficiency and Cost Effectiveness, *edited by Peter G Welling, Louis Lasagna, and Umesh V Banakar*
- 77 Microparticulate Systems for the Delivery of Proteins and Vaccines, *edited by Smadar Cohen and Howard Bernstein*
- 78 Good Manufacturing Practices for Pharmaceuticals A Plan for Total Quality Control, Fourth Edition, Revised and Expanded, *Sidney H Willig and James R Stoker*
- 79 Aqueous Polymeric Coatings for Pharmaceutical Dosage Forms Second Edition, Revised and Expanded, *edited by James W McGinity*
- 80 Pharmaceutical Statistics Practical and Clinical Applications, Third Edition, *Sanford Bolton*
- 81 Handbook of Pharmaceutical Granulation Technology *edited by Dilip M Pankh*
- 82 Biotechnology of Antibiotics Second Edition, Revised and Expanded, *edited by William R Strohl*
- 83 Mechanisms of Transdermal Drug Delivery, *edited by Russell O Potts and Richard H Guy*
- 84 Pharmaceutical Enzymes *edited by Albert Lauwers and Simon Scharpe*
- 85 Development of Biopharmaceutical Parenteral Dosage Forms, *edited by John A Bontempo*
- 86 Pharmaceutical Project Management, *edited by Tony Kennedy*
- 87 Drug Products for Clinical Trials An International Guide to Formulation • Production • Quality Control, *edited by Donald C Monkhouse and Christopher T Rhodes*
- 88 Development and Formulation of Veterinary Dosage Forms Second Edition, Revised and Expanded, *edited by Gregory E Hardee and J Desmond Baggot*
- 89 Receptor-Based Drug Design, *edited by Paul Leff*
- 90 Automation and Validation of Information in Pharmaceutical Processing, *edited by Joseph F deSpautz*
- 91 Dermal Absorption and Toxicity Assessment, *edited by Michael S Roberts and Kenneth A Walters*
- 92 Pharmaceutical Experimental Design, *Gareth A Lewis, Didier Mathieu, and Roger Phan-Tan-Luu*
- 93 Preparing for FDA Pre-Approval Inspections, *edited by Martin D Hynes III*
- 94 Pharmaceutical Excipients Characterization by IR, Raman, and NMR Spectroscopy, *David E Bugay and W Paul Findlay*
- 95 Polymorphism in Pharmaceutical Solids, *edited by Harry G Brittain*
- 96 Freeze-Drying/Lyophilization of Pharmaceutical and Biological Products, *edited by Louis Rey and Joan C May*
- 97 Percutaneous Absorption Drugs–Cosmetics–Mechanisms–Methodology, Third Edition, Revised and Expanded, *edited by Robert L Bronaugh and Howard I Maibach*

98. Bioadhesive Drug Delivery Systems: Fundamentals, Novel Approaches, and Development, *edited by Edith Mathiowitz, Donald E. Chickering III, and Claus-Michael Lehr*
99. Protein Formulation and Delivery, *edited by Eugene J. McNally*
100. New Drug Approval Process: Third Edition, The Global Challenge, *edited by Richard A. Guarino*
101. Peptide and Protein Drug Analysis, *edited by Ronald E. Reid*
102. Transport Processes in Pharmaceutical Systems, *edited by Gordon L. Amidon, Ping I. Lee, and Elizabeth M. Topp*
103. Excipient Toxicity and Safety, *edited by Myra L. Weiner and Lois A. Kotkoskie*
104. The Clinical Audit in Pharmaceutical Development, *edited by Michael R. Hamrell*
105. Pharmaceutical Emulsions and Suspensions, *edited by Francoise Nelloud and Gilberte Marti-Mestres*
106. Oral Drug Absorption: Prediction and Assessment, *edited by Jennifer B. Dressman and Hans Lennernäs*
107. Drug Stability: Principles and Practices, Third Edition, Revised and Expanded, *edited by Jens T. Carstensen and C. T. Rhodes*
108. Containment in the Pharmaceutical Industry, *edited by James P. Wood*
109. Good Manufacturing Practices for Pharmaceuticals: A Plan for Total Quality Control from Manufacturer to Consumer, Fifth Edition, Revised and Expanded, *Sidney H Willig*
110. Advanced Pharmaceutical Solids, *Jens T Carstensen*
111. Endotoxins: Pyrogens, LAL Testing, and Depyrogenation, Second Edition, Revised and Expanded, *Kevin L. Williams*
112. Pharmaceutical Process Engineering, *Anthony J. Hickey and David Ganderton*
113. Pharmacogenomics, *edited by Werner Kalow, Urs A. Meyer, and Rachel F. Tyndale*
114. Handbook of Drug Screening, *edited by Ramakrishna Seethala and Prabhavathi B. Fernandes*
115. Drug Targeting Technology: Physical • Chemical • Biological Methods, *edited by Hans Schreier*
116. Drug–Drug Interactions, *edited by A. David Rodrigues*
117. Handbook of Pharmaceutical Analysis, *edited by Lena Ohannesian and Anthony J. Streeter*
118. Pharmaceutical Process Scale-Up, *edited by Michael Levin*
119. Dermatological and Transdermal Formulations, *edited by Kenneth A. Walters*
120. Clinical Drug Trials and Tribulations: Second Edition, Revised and Expanded, *edited by Allen Cato, Lynda Sutton, and Allen Cato III*
121. Modern Pharmaceutics: Fourth Edition, Revised and Expanded, *edited by Gilbert S. Banker and Christopher T. Rhodes*
122. Surfactants and Polymers in Drug Delivery, *Martin Malmsten*
123. Transdermal Drug Delivery: Second Edition, Revised and Expanded, *edited by Richard H. Guy and Jonathan Hadgraft*



124. Good Laboratory Practice Regulations: Second Edition, Revised and Expanded, *edited by Sandy Weinberg*
125. Parenteral Quality Control: Sterility, Pyrogen, Particulate, and Package Integrity Testing. Third Edition, Revised and Expanded, *Michael J. Akers, Daniel S. Lammore, and Dana Morton Guazzo*
126. Modified-Release Drug Delivery Technology, *edited by Michael J. Rathbone, Jonathan Hadgraft, and Michael S. Roberts*
127. Simulation for Designing Clinical Trials: A Pharmacokinetic-Pharmacodynamic Modeling Perspective, *edited by Hui C Kimko and Stephen B Duffull*
128. Affinity Capillary Electrophoresis in Pharmaceuticals and Biopharmaceutics, *edited by Reinhard H. H. Neubert and Hans-Hermann Rüttinger*
129. Pharmaceutical Process Validation: An International Third Edition, Revised and Expanded, *edited by Robert A Nash and Alfred H. Wachter*
130. Ophthalmic Drug Delivery Systems: Second Edition, Revised and Expanded, *edited by Ashim K. Mitra*
131. Pharmaceutical Gene Delivery Systems, *edited by Alain Rolland and Sean M. Sullivan*

#### ADDITIONAL VOLUMES IN PREPARATION

Biomarkers in Clinical Drug Development, *edited by John C Bloom and Robert A. Dean*

Pharmaceutical Inhalation Aerosol Technology: Second Edition, Revised and Expanded, *edited by Anthony J Hickey*

Pharmaceutical Extrusion Technology, *edited by Isaac Ghebre-Sellasie and Charles Martin*

Pharmaceutical Compliance, *edited by Carmen Medina*

Dedicated to Theodore E. Byers, formerly of the U.S. Food and Drug Administration, and Heinz Sucker, Professor at the University of Berne, Switzerland, for their pioneering contributions with respect to the pharmaceutical process validation concept. We also acknowledge the past contributions of Bernard T. Loftus and Ira R. Berry toward the success of *Pharmaceutical Process Validation*.

# Preface

The third edition of *Pharmaceutical Process Validation* represents a new approach to the topic in several important respects.

Many of us in the field had made the assumption that pharmaceutical process validation was an American invention, based on the pioneering work of Theodore E. Byers and Bernard T. Loftus, both formerly with the U.S. Food & Drug Administration. The truth is that many of our fundamental concepts of pharmaceutical process validation came to us from “Validation of Manufacturing Processes,” Fourth European Seminar on Quality Control, September 25, 1980, Geneva, Switzerland, and *Validation in Practice*, edited by H. Sucker, Wissenschaftliche Verlagsgesellschaft, GmbH, Stuttgart, Germany, 1983.

There are new chapters in this edition that will add to the book’s impact. They include “Validation for Medical Devices” by Nishihata, “Validation of Biotechnology Processes” by Sofer, “Transdermal Process Validation” by Neal, “Integrated Packaging Validation” by Frederick, “Statistical Methods for Uniformity and Dissolution Testing” by Bergum and Utter, “Change Control and SUPAC” by Waterland and Kowtna, “Validation in Contract Manufacturing” by Parikh, and “Harmonization, GMPs, and Validation” by Wachter.

I am pleased to have Dr. Alfred Wachter join me as coeditor of this edition. He was formerly head of Pharmaceutical Product Development for the CIBA Pharmaceutical Company in Basel, Switzerland, and also spent a number of years on assignment in Asia for CIBA. Fred brings a very strong international perspective to the subject matter.

*Robert A. Nash*

# Contents

*Preface*

*Contributors*

*Introduction*

1. **Regulatory Basis for Process Validation**  
*John M. Dietrick and Bernard T. Loftus*
2. **Prospective Process Validation**  
*Allen Y. Chao, F. St. John Forbes, Reginald F. Johnson,  
and Paul Von Doehren*
3. **Retrospective Validation**  
*Chester J. Trubinski*
4. **Sterilization Validation**  
*Michael J. Akers and Neil R. Anderson*
5. **Validation of Solid Dosage Forms**  
*Jeffrey S. Rudolph and Robert J. Sepelyak*
6. **Validation for Medical Devices**  
*Toshiaki Nishihata*
7. **Validation of Biotechnology Processes**  
*Gail Sofer*
8. **Transdermal Process Validation**  
*Charlie Neal, Jr.*
9. **Validation of Lyophilization**  
*Edward H. Trappier*

10. Validation of Inhalation Aerosols  
*Christopher J. Sciarra and John J. Sciarra*
11. Process Validation of Pharmaceutical Ingredients  
*Robert A. Nash*
12. Qualification of Water and Air Handling Systems  
*Kunio Kawamura*
13. Equipment and Facility Qualification  
*Thomas L. Peither*
14. Validation and Verification of Cleaning Processes  
*William E. Hall*
15. Validation of Analytical Methods and Processes  
*Ludwig Huber*
16. Computer System Validation:  
Controlling the Manufacturing Process  
*Tony de Claire*
17. Integrated Packaging Validation  
*Mervyn J. Frederick*
18. Analysis of Retrospective Production Data Using  
Quality Control Charts  
*Peter H. Cheng and John E. Dutt*
19. Statistical Methods for Uniformity and Dissolution Testing  
*James S. Bergum and Merlin L. Utter*
20. Change Control and SUPAC  
*Nellie Helen Waterland and Christopher C. Kowtna*
21. Process Validation and Quality Assurance  
*Carl B. Rifino*
22. Validation in Contract Manufacturing  
*Dilip M. Parikh*
23. Terminology of Nonaseptic Process Validation  
*Kenneth G. Chapman*
24. Harmonization, GMPs, and Validation  
*Alfred H. Wachter*

# Contributors

**Michael J. Akers** Baxter Pharmaceutical Solutions, Bloomington, Indiana, U.S.A.

**Neil R. Anderson** Eli Lilly and Company, Indianapolis, Indiana, U.S.A.

**James S. Bergum** Bristol-Myers Squibb Company, New Brunswick, New Jersey, U.S.A.

**Kenneth G. Chapman** Drumbeat Dimensions, Inc., Mystic, Connecticut, U.S.A.

**Allen Y. Chao** Watson Labs, Carona, California, U.S.A.

**Peter H. Cheng** New York State Research Foundation for Mental Hygiene, New York, New York, U.S.A.

**Tony de Claire** APDC Consulting, West Sussex, England

**John M. Dietrick** Center for Drug Evaluation and Research, U.S. Food and Drug Administration, Rockville, Maryland, U.S.A.

**John E. Dutt** EM Industries, Inc., Hawthorne, New York, U.S.A.

**Mervyn J. Frederick** NV Organon–Akzo Nobel, Oss, The Netherlands

**William E. Hall** Hall & Pharmaceutical Associates, Inc., Kure Beach, North Carolina, U.S.A.

**Ludwig Huber** Agilent Technologies GmbH, Waldbronn, Germany

**F. St. John Forbes** Wyeth Labs, Pearl River, New York, U.S.A.

\***Reginald F. Johnson** Searle & Co., Inc., Skokie, Illinois, U.S.A.

**Kunio Kawamura** Otsuka Pharmaceutical Co., Ltd., Tokushima, Japan

**Christopher C. Kowtna** DuPont Pharmaceuticals Co., Wilmington, Delaware, U.S.A.

\***Bernard T. Loftus** Bureau of Drugs, U.S. Food and Drug Administration, Washington, D.C., U.S.A.

**Robert A. Nash** Stevens Institute of Technology, Hoboken, New Jersey, U.S.A.

**Charlie Neal, Jr.** Diosynth-RTP, Research Triangle Park, North Carolina, U.S.A.

**Toshiaki Nishihata** Santen Pharmaceutical Co., Ltd., Osaka, Japan

**Dilip M. Parikh** APACE PHARMA Inc., Westminster, Maryland, U.S.A.

**Thomas L. Peither** PECON—Peither Consulting, Schopfheim, Germany

**Carl B. Rifino** AstraZeneca Pharmaceuticals LP, Newark, Delaware, U.S.A.

**Jeffrey S. Rudolph** Pharmaceutical Consultant, St. Augustine, Florida, U.S.A.

**Christopher J. Sciarra** Sciarra Laboratories Inc., Hicksville, New York, U.S.A.

**John J. Sciarra** Sciarra Laboratories Inc., Hicksville, New York, U.S.A.

**Robert J. Sepelyak** AstraZeneca Pharmaceuticals LP, Wilmington, Delaware, U.S.A.

**Gail Sofer** BioReliance, Rockville, Maryland, U.S.A.

**Edward H. Trappier** Lyophilization Technology, Inc., Warwick, Pennsylvania, U.S.A.

---

\*Retired

**Chester J. Trubinski** Church & Dwight Co., Inc., Princeton, New Jersey, U.S.A.

**Merlin L. Utter** Wyeth Pharmaceuticals, Pearl River, New York, U.S.A.

**Paul Von Doehren** Searle & Co., Inc., Skokie, Illinois, U.S.A.

**Alfred H. Wachter** Wachter Pharma Projects, Therwil, Switzerland

**Nellie Helen Waterland** DuPont Pharmaceuticals Co., Wilmington, Delaware, U.S.A.



# Introduction

**Robert A. Nash**

*Stevens Institute of Technology, Hoboken, New Jersey, U.S.A.*

## I. FDA GUIDELINES

The U.S. Food and Drug Administration (FDA) has proposed guidelines with the following definition for *process validation* [1]:

Process validation is establishing documented evidence which provides a high degree of assurance that a specific process (such as the manufacture of pharmaceutical dosage forms) will consistently produce a product meeting its predetermined specifications and quality characteristics.

According to the FDA, assurance of product quality is derived from careful and systemic attention to a number of important factors, including: selection of quality components and materials, adequate product and process design, and (statistical) control of the process through in-process and end-product testing.

Thus, it is through careful design (qualification) and validation of both the process and its control systems that a high degree of confidence can be established that all individual manufactured units of a given batch or succession of batches that meet specifications will be acceptable.

According to the FDA's Current Good Manufacturing Practices (CGMPs) 21CFR 211.110 a:

Control procedures shall be established to *monitor* output and to *validate* performance of the manufacturing processes that may be responsible for causing variability in the characteristics of in-process material and the drug product. Such control procedures shall include, but are not limited to the following, where appropriate [2]:

1. Tablet or capsule weight variation
2. Disintegration time

3. Adequacy of mixing to assure uniformity and homogeneity
4. Dissolution time and rate
5. Clarity, completeness, or pH of solutions

The first four items listed above are directly related to the manufacture and validation of solid dosage forms. Items 1 and 3 are normally associated with variability in the manufacturing process, while items 2 and 4 are usually influenced by the selection of the ingredients in the product formulation. With respect to content uniformity and unit potency control (item 3), adequacy of mixing to assure uniformity and homogeneity is considered a high-priority concern.

Conventional quality control procedures for finished product testing encompass three basic steps:

1. Establishment of specifications and performance characteristics
2. Selection of appropriate methodology, equipment, and instrumentation to ensure that testing of the product meets specifications
3. Testing of the final product, using validated analytical and testing methods to ensure that finished product meets specifications.

With the emergence of the pharmaceutical process validation concept, the following four additional steps have been added:

4. Qualification of the processing facility and its equipment
5. Qualification and validation of the manufacturing process through appropriate means
6. Auditing, monitoring, sampling, or challenging the key steps in the process for conformance to in-process and final product specifications
7. Revalidation when there is a significant change in either the product or its manufacturing process [3].

## **II. TOTAL APPROACH TO PHARMACEUTICAL PROCESS VALIDATION**

It has been said that there is no specific basis for requiring a separate set of process validation guidelines, since the essentials of process validation are embodied within the purpose and scope of the present CGMP regulations [2]. With this in mind, the entire CGMP document, from subpart B through subpart K, may be viewed as being a set of principles applicable to the *overall process* of manufacturing, i.e., medical devices (21 CFR–Part 820) as well as drug products, and thus may be subjected, subpart by subpart, to the application of the principles of qualification, validation, verification and control, in addition to change control and revalidation, where applicable. Although not a specific re-

quirement of current regulations, such a comprehensive approach with respect to each subpart of the CGMP document has been adopted by many drug firms.

A checklist of qualification and control documentation with respect to CGMPs is provided in Table 1. A number of these topics are discussed separately in other chapters of this book.

### III. WHY ENFORCE PROCESS VALIDATION?

The FDA, under the authority of existing CGMP regulations, guidelines [1], and directives [3], considers process validation necessary because it makes good engineering sense. The basic concept, according to Mead [5], has long been

**Table 1** Checklist of Qualification and Control Documentation

Subpart	Section of CGMPs	Qualification and control documentation
A	General provisions	
B	Organization and personnel	Responsibilities of the quality control unit
C	Buildings and facilities	Plant and facility installation and qualification Maintenance and sanitation Microbial and pest control
D	Equipment	Installation and qualification of equipment and cleaning methods
E	Control of components, containers and closures	Incoming component testing procedures
F	Production and process controls	Process control systems, reprocessing control of microbial contamination
G	Packaging and labeling controls	Depyrogenation, sterile packaging, filling and closing, expire dating
H	Holding and distribution	Warehousing and distribution procedures
I	Laboratory controls	Analytical methods, testing for release component testing and stability testing
J	Records and reports	Computer systems and information systems
K	Return and salvaged drug products	Batch reprocessing

Sterilization procedures, Air and water quality are covered in appropriate subparts of Table 1.

applied in other industries, often without formal recognition that such a concept was being used. For example, the terms *reliability engineering* and qualification have been used in the past by the automotive and aerospace industries to represent the process validation concept.

The application of *process validation* should result in fewer product recalls and troubleshooting assignments in manufacturing operations and more technically and economically sound products and their manufacturing processes. In the old days R & D “gurus” would literally hand down the “go” sometimes overformulated product and accompanying obtuse manufacturing procedure, usually with little or no justification or rationale provided. Today, under FDA’s *Preapproval Inspection* (PAI) program [4] such actions are no longer acceptable. The watchword is to provide scientifically sound justifications (including qualification and validation documentation) for everything that comes out of the pharmaceutical R & D function.

#### IV. WHAT IS PROCESS VALIDATION?

Unfortunately, there is still much confusion as to what process validation is and what constitutes process validation documentation. At the beginning of this introduction several different definitions for process validation were provided, which were taken from FDA guidelines and the CGMPs. Chapman calls process validation simply “organized, documented common sense” [6]. Others have said that “it is more than three good manufactured batches” and should represent a lifetime commitment as long as the product is in production, which is pretty much analogous to the *retrospective process validation* concept.

The big problem is that we use the term *validation* generically to cover the entire spectrum of CGMP concerns, most of which are essentially people, equipment, component, facility, methods, and procedural *qualification*. The specific term *process validation* should be reserved for the final stage(s) of the product/process development sequence. The essential or key steps or stages of a successfully completed product/process development program are presented in [Table 2](#) [7].

The end of the sequence that has been assigned to process validation is derived from the fact that the specific exercise of process validation should never be designed to fail. Failure in carrying out the process validation assignment is often the result of incomplete or faulty understanding of the process’s capability, in other words, what the process can and cannot do under a given set of operational circumstances. In a well-designed, well-run overall validation program, most of the budget dollars should be spent on equipment, component, facility, methods qualification, and process demonstration, formerly called process qualification. In such a program, the formalized final process validation

**Table 2** The Key Stages in the Product/Process Development Sequence

Development stage	Pilot scale-up phase
Product design	1 × batch size
Product characterization	
Product selection (“go” formula)	
Process design	
Product optimization	10 × batch size
Process characterization	
Process optimization	
Process demonstration	100 × batch size
Process validation program	
Product/process certification	

With the exception of solution products, the bulk of the work is normally carried out at 10 × batch size, which is usually the first scale-up batches in production-type equipment.

sequence provides only the necessary process validation documentation required by the regulatory authorities—in other words, the “Good Housekeeping Seal of Approval,” which shows that the manufacturing process is in a state of control.

Such a strategy is consistent with the U.S. FDA’s *preapproval inspection program* [4], wherein the applicant firm under either a New Drug Application (NDA) or an Abbreviated New Drug Application (ANDA) submission must show the necessary CGMP information and qualification data (including appropriate development reports), together with the formal protocol for the forthcoming full-scale, formal process validation runs required prior to product launch.

Again, the term *validation* has both a specific meaning and a general one, depending on whether the word “process” is used. Determine during the course of your reading whether the entire concept is discussed in connection with the topic—i.e., design, characterization, optimization, qualification, validation, and/or revalidation—or whether the author has concentrated on the specifics of the validation of a given product and/or its manufacturing process. In this way the text will take on greater meaning and clarity.

## V. PILOT SCALE-UP AND PROCESS VALIDATION

The following operations are normally carried out by the development function prior to the preparation of the first pilot-production batch. The development activities are listed as follows:

1. Formulation design, selection, and optimization
2. Preparation of the first pilot-laboratory batch
3. Conduct initial accelerated stability testing
4. If the formulation is deemed stable, preparation of additional pilot-laboratory batches of the drug product for expanded nonclinical and/or clinical use.

The pilot program is defined as the scale-up operations conducted subsequent to the product and its process leaving the development laboratory and prior to its acceptance by the full scale manufacturing unit. For the pilot program to be successful, elements of process validation must be included and completed during the developmental or pilot laboratory phase of the work.

Thus, product and process scale-up should proceed in graduated steps with elements of process validation (such as qualifications) incorporated at each stage of the piloting program [9,10].

### **A. Laboratory Batch**

The first step in the scale-up process is the selection of a suitable preliminary formula for more critical study and testing based on certain agreed-upon initial design criteria, requirements, and/or specifications. The work is performed in the development laboratory. The formula selected is designated as the ( $1 \times$ ) laboratory batch. The size of the ( $1 \times$ ) laboratory batch is usually 3–10 kg of a solid or semisolid, 3–10 liters of a liquid, or 3000 to 10,000 units of a tablet or capsule.

### **B. Laboratory Pilot Batch**

After the ( $1 \times$ ) laboratory batch is determined to be both physically and chemically stable based on accelerated, elevated temperature testing (e.g., 1 month at 45°C or 3 months at 40°C or 40°C/80% RH), the next step in the scale-up process is the preparation of the ( $10 \times$ ) laboratory pilot batch. The ( $10 \times$ ) laboratory pilot batch represents the first replicated scale-up of the designated formula. The size of the laboratory pilot batch is usually 30–100 kg, 30–100 liters, or 30,000 to 100,000 units.

It is usually prepared in small pilot equipment within a designated CGMP-approved area of the development laboratory. The number and actual size of the laboratory pilot batches may vary in response to one or more of the following factors:

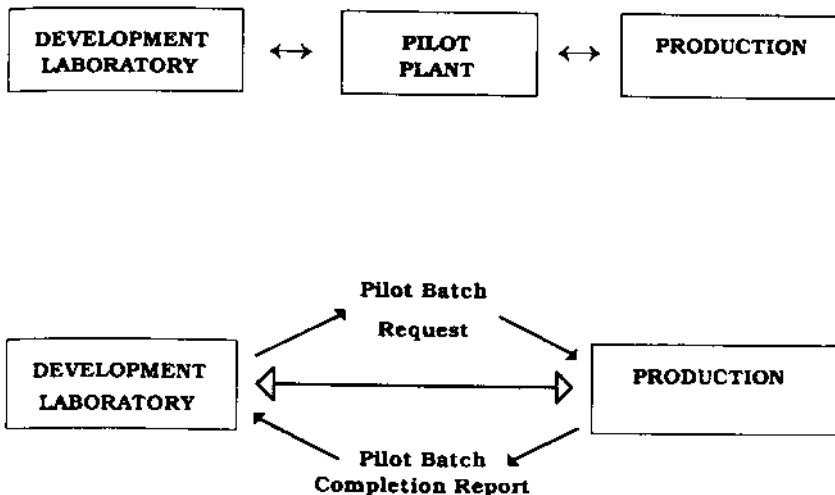
1. Equipment availability
2. Active pharmaceutical ingredient (API)

3. Cost of raw materials
4. Inventory requirements for clinical and nonclinical studies

Process demonstration or process capability studies are usually started in this important second stage of the pilot program. Such capability studies consist of process ranging, process characterization, and process optimization as a prerequisite to the more formal validation program that follows later in the piloting sequence.

### C. Pilot Production

The pilot-production phase may be carried out either as a shared responsibility between the development laboratories and its appropriate manufacturing counterpart or as a process demonstration by a separate, designated pilot-plant or process-development function. The two organization piloting options are presented separately in Figure 1. The creation of a separate pilot-plant or process-development unit has been favored in recent years because it is ideally suited to carry out process scale-up and/or validation assignments in a timely manner. On the other hand, the joint pilot-operation option provides direct communication between the development laboratory and pharmaceutical production.



**Figure 1** Main piloting options. (Top) Separate pilot plant functions—engineering concept. (Bottom) Joint pilot operation.

The object of the pilot-production batch is to scale the product and process by another order of magnitude ( $100\times$ ) to, for example, 300–1,000 kg, 300–1,000 liters, or 300,000–1,000,000 dosage form units (tablets or capsules) in size. For most drug products this represents a full production batch in standard production equipment. If required, pharmaceutical production is capable of scaling the product/process to even larger batch sizes should the product require expanded production output. If the batch size changes significantly, additional validation studies would be required. The term product/process is used, since one can't describe a product with discussing its process of manufacture and, conversely, one can't talk about a process without describing the product being manufactured.

Usually large production batch scale-up is undertaken only after product introduction. Again, the actual size of the pilot-production ( $100\times$ ) batch may vary due to equipment and raw material availability. The need for additional pilot-production batches ultimately depends on the successful completion of a first pilot batch and its process validation program. Usually three successfully completed pilot-production batches are required for validation purposes.

In summary, process capability studies start in the development laboratories and/or during product and process development, and continue in well-defined stages until the process is validated in the pilot plant and/or pharmaceutical production.

An approximate timetable for new product development and its pilot scale-up program is suggested in [Table 3](#).

## **VI. PROCESS VALIDATION: ORDER OF PRIORITY**

Because of resource limitation, it is not always possible to validate an entire company's product line at once. With the obvious exception that a company's most profitable products should be given a higher priority, it is advisable to draw up a list of product categories to be validated.

The following order of importance or priority with respect to validation is suggested:

### **A. Sterile Products and Their Processes**

1. Large-volume parenterals (LVPs)
2. Small-volume parenterals (SVPs)
3. Ophthalmics, other sterile products, and medical devices



**Table 3** Approximate Timetable for New Product Development and Pilot Scale-Up Trials

Event	Calendar months
Formula selection and development	2–4
Assay methods development and formula optimization	2–4
Stability in standard packaging 3-month readout (1 × size)	3–4
Pilot-laboratory batches (10 × size)	1–3
Preparation and release of clinical supplies (10 × size) and establishment of process demonstration	1–4
Additional stability testing in approved packaging 6–8-month readout (1 × size)	3–4
3-month readout (10 × size)	
Validation protocols and pilot batch request	1–3
Pilot-production batches (100 × size)	1–3
Additional stability testing in approved packaging 9–12-month readout (1 × size)	3–4
6–8-month readout (10 × size)	
3-month readout (100 × size)	
Interim approved technical product development report with approximately 12 months stability (1 × size)	1–3
Totals	18–36

## B. Nonsterile Products and Their Processes

1. Low-dose/high-potency tablets and capsules/transdermal delivery systems (TDDs)
2. Drugs with stability problems
3. Other tablets and capsules
4. Oral liquids, topicals, and diagnostic aids

## VII. WHO DOES PROCESS VALIDATION?

Process validation is done by individuals with the necessary training and experience to carry out the assignment.

The specifics of how a dedicated group, team, or committee is organized to conduct process validation assignments is beyond the scope of this introductory chapter. The responsibilities that must be carried out and the organizational structures best equipped to handle each assignment are outlined in [Table 4](#). The

**Table 4** Specific Responsibilities of Each Organizational Structure within the Scope of Process Validation

---

Engineering	Install, qualify, and certify plant, facilities, equipment, and support system.
Development	Design and optimize manufacturing process within design limits, specifications, and/or requirements—in other words, the establishment of process capability information.
Manufacturing	Operate and maintain plant, facilities, equipment, support systems, and the specific manufacturing process within its design limits, specifications, and/or requirements.
Quality assurance	Establish approvable validation protocols and conduct process validation by monitoring, sampling, testing, challenging, and/or auditing the specific manufacturing process for compliance with design limits, specifications, and/or requirements.

---

Source: Ref. 8.

best approach in carrying out the process validation assignment is to establish a Chemistry, Manufacturing and Control (CMC) Coordination Committee at the specific manufacturing plant site [10]. Representation on such an important logistical committee should come from the following technical operations:

- Formulation development (usually a laboratory function)
- Process development (usually a pilot plant function)
- Pharmaceutical manufacturing (including packaging operations)
- Engineering (including automation and computer system responsibilities)
- Quality assurance
- Analytical methods development and/or Quality Control
- API Operations (representation from internal operations or contract manufacturer)
- Regulatory Affairs (technical operations representative)
- IT (information technology) operations

The chairperson or secretary of such an important site CMC Coordination Committee should include the manager of process validation operations. Typical meeting agendas may include the following subjects in the following recommended order of priority:

- Specific CGMP issues for discussion and action to be taken
- Qualification and validation issues with respect to a new product/process

- Technology transfer issues within or between plant sites.
- Pre-approval inspection (PAI) issues of a forthcoming product/process
- Change control and scale-up, post approval changes (SUPAC) with respect to current approved product/process [11].

## VIII. PROCESS DESIGN AND CHARACTERIZATION

*Process capability* is defined as the studies used to determine the *critical* process parameters or operating variables that influence process output and the range of numerical data for critical process parameters that result in acceptable process output. If the capability of a process is properly delineated, the process should consistently stay within the defined limits of its critical process parameters and product characteristics [12].

*Process demonstration* formerly called process qualification, represents the actual studies or trials conducted to show that all systems, subsystems, or unit operations of a manufacturing process perform as intended; that all critical process parameters operate within their assigned control limits; and that such studies and trials, which form the basis of process capability design and testing, are verifiable and certifiable through appropriate documentation.

The manufacturing process is briefly defined as the ways and means used to convert raw materials into a finished product. The ways and means also include people, equipment, facilities, and support systems required to operate the process in a planned and effectively managed way. All the latter functions must be qualified individually. The master plan or protocol for process capability design and testing is presented in [Table 5](#).

A simple flow chart should be provided to show the logistical sequence of unit operations during product/process manufacture. A typical flow chart used in the manufacture of a tablet dosage form by the wet granulation method is presented in [Figure 2](#).

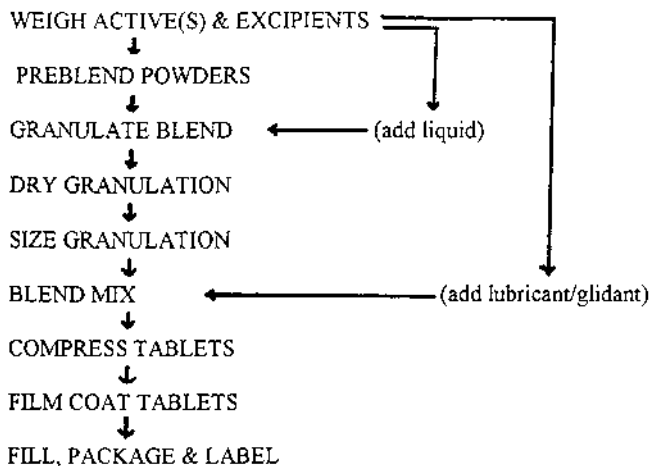
## IX. STREAMLINING VALIDATION OPERATIONS

The best approach to avoiding needless and expensive technical delays is to work in parallel. The key elements at this important stage of the overall process are the API, analytical test methods, and the drug product (pharmaceutical dosage form). An integrated and parallel way of getting these three vitally important functions to work together is depicted in [Figure 3](#).

Figure 3 shows that the use of a single analytical methods testing function is an important technical bridge between the API and the drug product development functions as the latter two move through the various stages of develop-

**Table 5** Master Plan or Protocol for Process Capability Design and Testing

Objective	Process capability design and testing
Types of process	Batch, intermittent, continuous
Typical processes	Chemical, pharmaceutical, biochemical
Process definition	Flow diagram, in-process, finished product
Definition of process output	Potency, yield, physical parameters
Definition of test methods	Instrumentation, procedures, precision, and accuracy
Process analysis	Process variables, matrix design, factorial design analysis
Pilot batch trials	Define sampling and testing, stable, extended runs
Pilot batch replication	Different days, different materials, different equipment
Process redefinition	Reclassification of process variables
Process capability evaluation	Stability and variability of process output, economic limits
Final report	Recommended SOP, specifications, and process limits



**Figure 2** Process flow diagram for the manufacture of a tablet dosage form by wet granulation method. The arrows show the transfer of material into and out of each of the various unit operations. The information in parentheses indicates additions of material to specific unit operations. A list of useful pharmaceutical unit operations is presented in [Table 6](#).

**Table 6** A List of Useful Pharmaceutical Unit Operations According to Categories

---

*Heat transfer processes:* Cooking, cooling, evaporating, freezing, heating, irradiating, sterilizing, freeze-drying

*Change in state:* Crystallizing, dispersing, dissolving, immersing, freeze-drying, neutralizing

*Change in size:* Agglomerating, blending, coating, compacting, crushing, crystallizing, densifying, emulsifying, extruding, flaking, flocculating, grinding, homogenizing, milling, mixing, pelletizing, pressing, pulverizing, precipitating, sieving

*Moisture transfer processes:* Dehydrating, desiccating, evaporating, fluidizing, humidifying, freeze-drying, washing, wetting

*Separation processes:* Centrifuging, clarifying, deaerating, degassing, deodorizing, dialyzing, exhausting, extracting, filtering, ion exchanging, pressing, sieving, sorting, washing

*Transfer processes:* Conveying, filling, inspecting, pumping, sampling, storing, transporting, weighing

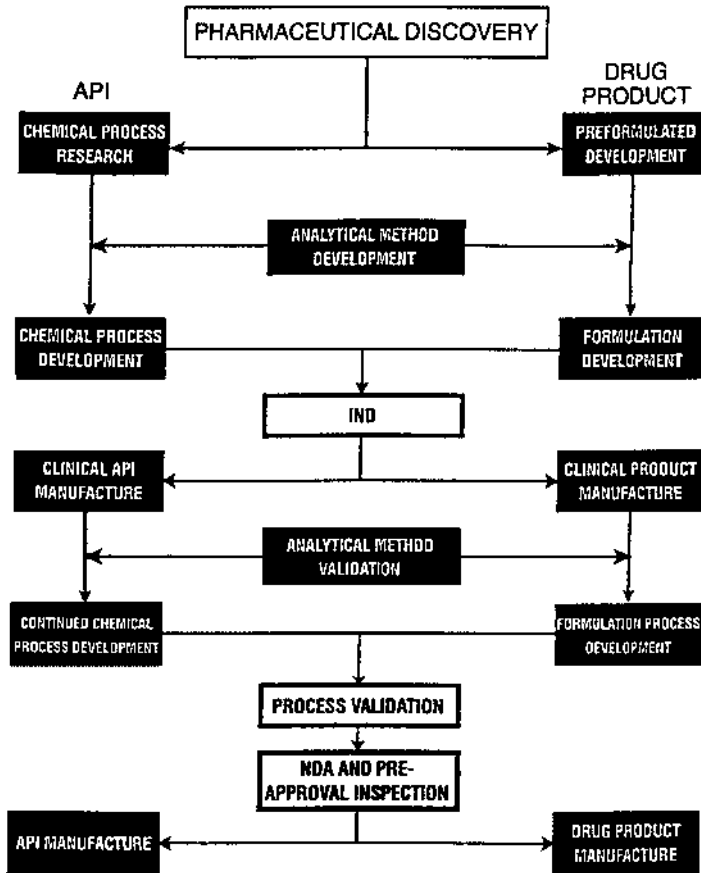
---

Source: Ref. 13.

ment, clinical study, process development, and process validation and into production. Working individually with separate analytical testing functions and with little or no appropriate communication among these three vital functions is a prescription for expensive delays. It is important to remember that the concept illustrated in [Figure 3](#) can still be followed even when the API is sourced from outside the plant site or company. In this particular situation there will probably be two separate analytical methods development functions: one for the API manufacturer and one for the drug product manufacturer [14].

## **X. STATISTICAL PROCESS CONTROL AND PROCESS VALIDATION**

*Statistical process control (SPC)*, also called statistical quality control and *process validation (PV)*, represents two sides of the same coin. SPC comprises the various mathematical tools (histogram, scatter diagram run chart, and control chart) used to monitor a manufacturing process and to keep it within in-process and final product specification limits. Lord Kelvin once said, “When you can measure what you are speaking about, and express it in numbers, then you know something about it.” Such a thought provides the necessary link between the two concepts. Thus, SPC represents the tools to be used, while PV represents the procedural environment in which those tools are used.



**Figure 3** Working in parallel. (Courtesy of Austin Chemical Co., Inc.)

There are three ways of establishing quality products and their manufacturing processes:

1. In-process and final product testing, which normally depends on sampling size (the larger the better). In some instances, nothing short of excessive sampling can ensure reaching the desired goal, i.e., sterility testing.
2. Establishment of tighter (so called “in-house”) control limits that hold the product and the manufacturing process to a more demanding stan-

dard will often reduce the need for more extensive sampling requirements.

3. The modern approach, based on Japanese quality engineering [15], is the pursuit of “zero defects” by applying tighter control over process variability (meeting a so-called 6 sigma standard). Most pharmaceutical products and their manufacturing processes in the United States today, with the exception of sterile processes are designed to meet a 4 sigma limit (which would permit as many as eight defects per 1000 units). The new approach is to center the process (in which the grand average is roughly equal to 100% of label potency or the target value of a given specification) and to reduce the process variability or noise around the mean or to achieve minimum variability by holding both to the new standard, batch after batch. In so doing, a 6 sigma limit may be possible (which is equivalent to not more than three to four defects per 1 million units), also called “zero defects.” The goal of 6 sigma, “zero defects” is easier to achieve for liquid than for solid pharmaceutical dosage forms [16].

*Process characterization* represents the methods used to determine the critical unit operations or processing steps and their process variables, that usually affect the quality and consistency of the product outcomes or product attributes. Process ranging represents studies that are used to identify critical process or test parameters and their respective control limits, which normally affect the quality and consistency of the product outcomes of their attributes. The following process characterization techniques may be used to designate critical unit operations in a given manufacturing process.

## **A. Constraint Analysis**

One procedure that makes subsystem evaluations and performance qualification trials manageable is the application of constraint analysis. Boundary limits of any technology and restrictions as to what constitutes acceptable output from unit operations or process steps should in most situations constrain the number of process variables and product attributes that require analysis. The application of the constraint analysis principle should also limit and restrict the operational range of each process variable and/or specification limit of each product attribute. Information about constraining process variables usually comes from the following sources:

- Previous successful experience with related products/processes
- Technical and engineering support functions and outside suppliers
- Published literatures concerning the specific technology under investigation

A practical guide to constraint analysis comes to us from the application of the *Pareto Principle* (named after an Italian sociologist) and is also known as the 80–20 rule, which simply states that about 80% of the process output is governed by about 20% of the input variables and that our primary job is to find those key variables that drive the process.

The FDA in their proposed amendments to the CGMPs [17] have designated that the following unit operations are considered *critical* and therefore their processing variables must be controlled and not disregarded:

- Cleaning
- Weighing/measuring
- Mixing/blending
- Compression/encapsulation
- Filling/packaging/labeling

## B. Fractional Factorial Design

An experimental design is a series of statistically sufficient qualification trials that are planned in a specific arrangement and include all processing variables that can possibly affect the expected outcome of the process under investigation. In the case of a *full factorial design*,  $n$  equals the number of factors or process variables, each at two levels, i.e., the upper (+) and lower (–) control limits. Such a design is known as a  $2^n$  factorial. Using a large number of process variables (say, 9) we could, for example, have to run  $2^9$ , or 512, qualification trials in order to complete the full factorial design.

The fractional factorial is designed to reduce the number of qualification trials to a more reasonable number, say, 10, while holding the number of randomly assigned processing variables to a reasonable number as well, say, 9. The technique was developed as a nonparametric test for process evaluation by Box and Hunter [18] and reviewed by Hendrix [19]. Ten is a reasonable number of trials in terms of resource and time commitments and should be considered an upper limit in a practical testing program. This particular design as presented in [Table 7](#) does not include interaction effects.

## XI. OPTIMIZATION TECHNIQUES

Optimization techniques are used to find either the best possible quantitative formula for a product or the best possible set of experimental conditions (input values) needed to run the process. Optimization techniques may be employed in the laboratory stage to develop the most stable, least sensitive formula, or in the qualification and validation stages of scale-up in order to develop the most sta-



**Table 7** Fractional Factorial Design (9 Variables in 10 Experiments)

Trial no.	X <sub>1</sub>	X <sub>2</sub>	X <sub>3</sub>	X <sub>4</sub>	X <sub>5</sub>	X <sub>6</sub>	X <sub>7</sub>	X <sub>8</sub>	X <sub>9</sub>
1	-	-	-	-	-	-	-	-	-
2	+	-	-	-	-	-	-	-	-
3	-	-	-	+	-	-	-	-	+
4	+	-	+	-	-	-	+	-	-
5	-	+	-	+	-	+	-	+	-
6	+	-	+	-	+	-	+	-	+
7	-	+	-	+	+	+	-	+	+
8	+	+	+	-	+	+	+	+	-
9	-	+	+	+	+	+	+	+	+
10	+	+	+	+	+	+	+	+	+

Worst-case conditions: Trial 1 (lower control limit). Trial 10 (upper control limit). X variables randomly assigned. Best values to use are RSD of data set for each trial. When adding up the data by columns, + and - are now numerical values and the sum is divided by 5 (number of +s or -s). If the variable is not significant, the sum will approach zero.

ble, least variable, robust process within its proven acceptable range(s) of operation, Chapman's so-called proven acceptable range (PAR) principle [20].

Optimization techniques may be classified as parametric statistical methods and nonparametric search methods. *Parametric statistical methods*, usually employed for optimization, are full factorial designs, half factorial designs, simplex designs, and Lagrangian multiple regression analysis [21]. Parametric methods are best suited for formula optimization in the early stages of product development. *Constraint analysis*, described previously, is used to simplify the testing protocol and the analysis of experimental results.

The steps involved in the parametric optimization procedure for pharmaceutical systems have been fully described by Schwartz [22]. Optimization techniques consist of the following essential operations:

1. Selection of a suitable experimental design
2. Selection of variables (independent Xs and dependent Ys) to be tested
3. Performance of a set of statistically designed experiments (e.g., 2<sup>3</sup> or 3<sup>2</sup> factorials)
4. Measurement of responses (dependent variables)
5. Development of a predictor, polynomial equation based on statistical and regression analysis of the generated experimental data
6. Development of a set of optimized requirements for the formula based on mathematical and graphical analysis of the data generated

## XII. WHAT ARE THE PROCESS VALIDATION OPTIONS?

The guidelines on general principles of process validation [1] mention three options: (1) prospective process validation (also called premarket validation), (2) retrospective process validation, and (3) revalidation. In actuality there are four possible options.

### A. Prospective Process Validation

In prospective process validation, an experimental plan called the *validation protocol* is executed (following completion of the qualification trials) before the process is put into commercial use. Most validation efforts require some degree of prospective experimentation to generate validation support data. This particular type of process validation is normally carried out in connection with the introduction of new drug products and their manufacturing processes. *The formalized process validation program should never be undertaken unless and until the following operations and procedures have been completed satisfactorily:*

1. The facilities and equipment in which the process validation is to be conducted meet CGMP requirements (completion of *installation qualification*)
2. The operators and supervising personnel who will be “running” the validation batch(es) have an understanding of the process and its requirements
3. The design, selection, and optimization of the formula have been completed
4. The qualification trials using (10 × size) pilot-laboratory batches have been completed, in which the critical processing steps and process variables have been identified, and the provisional operational control limits for each critical test parameter have been provided
5. Detailed technical information on the product and the manufacturing process have been provided, including documented evidence of product stability
6. Finally, at least one qualification trial of a pilot-production (100 × size) batch has been made and shows, upon scale-up, that there were no significant deviations from the expected performance of the process

The steps and sequence of events required to carry out a process validation assignment are outlined in [Table 8](#). The objective of prospective validation is to prove or demonstrate that the process will work in accordance with a validation master plan or protocol prepared for pilot-product (100 × size) trials.

In practice, usually two or three pilot-production (100 ×) batches are prepared for validation purposes. The first batch to be included in the sequence

**Table 8** Master Plan or Outline of a Process Validation Program

---

Objective	Proving or demonstrating that the process works
Type of validation	Prospective, concurrent, retrospective, revalidation
Type of process	Chemical, pharmaceutical, automation, cleaning
Definition of process	Flow diagram, equipment/components, in-process, finished product
Definition of process output	Potency, yield, physical parameters
Definition of test methods	Method, instrumentation, calibration, traceability, precision, accuracy
Analysis of process	Critical modules and variables defined by process capability design and testing program
Control limits of critical variables	Defined by process capability design and testing program
Preparation of validation protocol	Facilities, equipment, process, number of validation trials, sampling frequency, size, type, tests to perform, methods used, criteria for success
Organizing for validation	Responsibility and authority
Planning validation trials	Timetable and PERT charting, material availability, and disposal
Validation trials	Supervision, administration, documentation
Validation finding	Data summary, analysis, and conclusions
Final report and recommendations	Process validated, further trials, more process design, and testing

---

may be the already successfully concluded first pilot batch at  $100 \times$  size, which is usually prepared under the direction of the organizational function directly responsible for pilot scale-up activities. Later, replicate batch manufacture may be performed by the pharmaceutical production function.

The strategy selected for process validation should be simple and straightforward. The following factors are presented for the reader's consideration:

1. The use of different lots of components should be included, i.e., APIs and major excipients.
2. Batches should be run in succession and on different days and shifts (the latter condition, if appropriate).
3. Batches should be manufactured in equipment and facilities designated for eventual commercial production.
4. Critical process variables should be set within their *operating ranges* and should not exceed their upper and lower control limits during process operation. Output responses should be well within finished product specifications.

5. Failure to meet the requirements of the validation protocol with respect to process inputs and output control should be subjected to *re-qualification* following a thorough analysis of process data and formal review by the CMC Coordination Committee.

## **B. Retrospective Validation**

The retrospective validation option is chosen for established products whose manufacturing processes are considered stable and when on the basis of economic considerations alone and resource limitations, prospective validation programs cannot be justified. Prior to undertaking retrospective validation, wherein the numerical in-process and/or end-product test data of historic production batches are subjected to statistical analysis, the equipment, facilities and subsystems used in connection with the manufacturing process must be qualified in conformance with CGMP requirements. The basis for retrospective validation is stated in 21CFR 211.110(b): “Valid in-process specifications for such characteristics shall be consistent with drug product final specifications and shall be derived from previous acceptable process average and process variability estimates where possible and determined by the application of suitable statistical procedures where appropriate.”

The concept of using accumulated final product as well as in-process numerical test data and batch records to provide documented evidence of product/process validation was originally advanced by Meyers [26] and Simms [27] of Eli Lilly and Company in 1980. The concept is also recognized in the FDA’s *Guidelines on General Principles of Process Validation* [1].

Using either data-based computer systems [28,29] or manual methods, retrospective validation may be conducted in the following manner:

1. Gather the numerical data from the completed batch record and include assay values, end-product test results, and in-process data.
2. Organize these data in a chronological sequence according to batch manufacturing data, using a spreadsheet format.
3. Include data from at least the last 20–30 manufactured batches for analysis. If the number of batches is less than 20, then include all manufactured batches and commit to obtain the required number for analysis.
4. Trim the data by eliminating test results from noncritical processing steps and delete all gratuitous numerical information.
5. Subject the resultant data to statistical analysis and evaluation.
6. Draw conclusions as to the state of control of the manufacturing process based on the analysis of retrospective validation data.
7. Issue a report of your findings (documented evidence).

One or more of the following output values (measured responses), which have been shown to be critical in terms of the specific manufacturing process being evaluated, are usually selected for statistical analysis.

## 1. Solid Dosage Forms

1. Individual assay results from content uniformity testing
2. Individual tablet hardness values
3. Individual tablet thickness values
4. Tablet or capsule weight variation
5. Individual tablet or capsule dissolution time (usually at  $t_{50\%}$ ) or disintegration time
6. Individual tablet or capsule moisture content

## 2. Semisolid and Liquid Dosage Forms

1. pH value (aqueous system)
2. Viscosity
3. Density
4. Color or clarity values
5. Average particle size or distribution
6. Unit weight variation and/or potency values

The statistical methods that may be employed to analyze numerical output data from the manufacturing process are listed as follows:

1. Basic statistics (mean, standard deviation, and tolerance limits) [21]
2. Analysis of variance (ANOVA and related techniques) [21]
3. Regression analysis [22]
4. Cumulative sum analysis (CUSUM) [23]
5. Cumulative difference analysis [23]
6. Control charting (averages and range) [24,25]

Control charting, with the exception of basic statistical analysis, is probably the most useful statistical technique to analyze retrospective and concurrent process data. Control charting forms the basis of modern statistical process control.

## C. Concurrent Validation

In-process monitoring of critical processing steps and end-product testing of current production can provide documented evidence to show that the manufacturing process is in a state of control. Such validation documentation can be provided from the test parameter and data sources disclosed in the section on retrospective validation.

Test parameter	Data source
Average unit potency	End-product testing
Content uniformity	End-product testing
Dissolution time	End-product testing
Weight variation	End-product testing
Powder-blend uniformity	In-process testing
Moisture content	In-process testing
Particle or granule size distribution	In-process testing
Weight variation	In-process testing
Tablet hardness	In-process testing
pH value	In-process testing
Color or clarity	In-process testing
Viscosity or density	In-process testing

Not all of the in-process tests enumerated above are required to demonstrate that the process is in a state of control. Selections of test parameters should be made on the basis of the *critical* processing variables to be evaluated.

#### D. Revalidation

Conditions requiring revalidation study and documentation are listed as follows:

1. Change in a *critical* component (usually refers to raw materials)
2. Change or replacement in a *critical* piece of modular (capital) equipment
3. Change in a facility and/or plant (usually location or site)
4. Significant (usually order of magnitude) increase or decrease in batch size
5. Sequential batches that fail to meet product and process specifications

In some situations performance requalification studies may be required prior to undertaking specific revalidation assignments.

The FDA process validation guidelines [1] refer to a quality assurance system in place that requires revalidation whenever there are changes in packaging (assumed to be the primary container-closure system), formulation, equipment or processes (meaning not clear) which could impact on product effectiveness or product characteristics and whenever there are changes in product characteristics.

Approved packaging is normally selected after completing package performance qualification testing as well as product compatibility and stability studies. Since in most cases (exceptions: transdermal delivery systems, diagnostic tests, and medical devices) packaging is not intimately involved in the manufacturing process of the product itself, it differs from other factors, such as raw materials.

The reader should realize that there is no one way to establish proof or evidence of process validation (i.e., a product and process in control). If the manufacturer is certain that its products and processes are under statistical control and in compliance with CGMP regulations, it should be a relatively simple matter to establish documented evidence of process validation through the use of prospective, concurrent, or retrospective pilot and/or product quality information and data. The choice of procedures and methods to be used to establish validation documentation is left with the manufacturer.

This introduction was written to aid scientists and technicians in the pharmaceutical and allied industries in the selection of procedures and approaches that may be employed to achieve a successful outcome with respect to product performance and process validation. The authors of the following chapters explore the same topics from their own perspectives and experience. It is hoped that the reader will gain much from the diversity and richness of these varied approaches.

## REFERENCES

1. *Guidelines on General Principles of Process Validation*, Division of Manufacturing and Product Quality, CDER, FDA, Rockville, Maryland (May 1987).
2. Current Good Manufacturing Practices in Manufacture, Processing, Packing and Holding of Human and Veterinary Drugs, *Federal Register* 43(190), 45085 and 45086, September 1978.
3. *Good Manufacturing Practices for Pharmaceuticals*, Willig, S. H. and Stoker, J. R., Marcel Dekker, New York (1997).
4. Commentary, Pre-approval Inspections/Investigations, FDA, *J. Parent. Sci. & Tech.* 45:56–63 (1991).
5. Mead, W. J., Process validation in cosmetic manufacture, *Drug Cosmet. Ind.*, (September 1981).
6. Chapman, K. G., A history of validation in the United States, Part I, *Pharm. Tech.*, (November 1991).
7. Nash, R. A., The essentials of pharmaceutical validation in *Pharmaceutical Dosage Forms: Tablets*, Vol. 3, 2nd ed., Lieberman, H. A., Lachman, L. and Schwartz, J. B., eds., Marcel Dekker, New York (1990).
8. Nash, R. A., Product formulation, *CHEMTECH*, (April 1976).
9. *Pharmaceutical Process Validation*, Berry, I. R. and Nash, R. A., eds., Marcel Dekker, New York (1993).
10. Nash, R. A., Making the Paper Match the Work, *Pharmaceutical Formulation & Quality* (Oct/Nov 2000).
11. Guidance for Industry, Scale-Up & Postapproval Changes, CDER, FDA (Nov 1995).
12. Bala, G., An integrated approach to process validation, *Pharm. Eng.* 14(3) (1994).
13. Farkas, D. F., Unit operations optimization operations, *CHEMTECH*, July 1977.

14. Nash, R. A., Streamlining Process Validation, *Amer. Pharm. Outsourcing* May 2001.
15. Ishikawa, K., *What is Total Quality Control? The Japanese Way*, Prentice-Hall, Englewood Cliffs, NJ (1985).
16. Nash, R. A., Practicality of Achieving Six Sigma or Zero-Defects in Pharmaceutical Systems, *Pharmaceutical Formulation & Quality*, Oct./Nov. 2001.
17. CGMP: Amendment of Certain Requirements, *FDA Federal Register*, May 3, 1996.
18. Box, G. E. and Hunter, J. S., *Statistics for Experimenters*, John Wiley, N.Y. (1978).
19. Hendrix, C. D., What every technologist should know about experimental design, *CHEMTECH* (March 1979).
20. Chapman, K. G., The PAR approach to process validation, *Pharm. Tech.*, Dec. 1984.
21. Bolton, S., *Pharmaceutical Statistics: Practical and Clinical Applications*, 3rd ed., Marcel Dekker, New York (1997).
22. Schwartz, J. B., Optimization techniques in product formulation. *J. Soc. Cosmet. Chem.* 32:287–301 (1981).
23. Butler, J. J., Statistical quality control, *Chem. Eng.* (Aug. 1983).
24. Deming, S. N., Quality by Design, *CHEMTECH*, (Sept. 1988).
25. Contino, AV., Improved plant performance with statistical process control, *Chem. Eng.* (July 1987).
26. Meyer, R. J., Validation of Products and Processes, PMA Seminar on Validation of Solid Dosage Form Processes, Atlanta, GA, May 1980.
27. Simms, L., Validation of Existing Products by Statistical Evaluation, Atlanta, GA, May 1980.
28. Agalloco, J. P., Practical considerations in retrospective validation, *Pharm. Tech.* (June 1983).
29. Kahan, J. S., Validating computer systems, *MD&DI* (March 1987).



# 1

## Regulatory Basis for Process Validation

**John M. Dietrick**

*U.S. Food and Drug Administration, Rockville, Maryland, U.S.A.*

**Bernard T. Loftus**

*U.S. Food and Drug Administration, Washington, D.C., U.S.A.*

### I. INTRODUCTION

Bernard T. Loftus was director of drug manufacturing in the Food and Drug Administration (FDA) in the 1970s, when the concept of process validation was first applied to the pharmaceutical industry and became an important part of current good manufacturing practices (CGMPs). His comments on the development and implementation of these regulations and policies as presented in the first and second editions of this volume are summarized below [1].

### II. WHAT IS PROCESS VALIDATION?

The term process validation is not defined in the Food, Drug, and Cosmetic Act (FD&C) Act or in FDA's CGMP regulations. Many definitions have been offered that in general express the same idea—that a process will do what it purports to do, or that the process works and the proof is documented. A June 1978 FDA compliance program on drug process inspections [2] contained the following definition:

---

This chapter was written by John M. Dietrick in his private capacity. No official support or endorsement by the Food and Drug Administration is intended or should be inferred.

A validated manufacturing process is one which has been proved to do what it purports or is represented to do. The proof of validation is obtained through the collection and evaluation of data, preferably, beginning from the process development phase and continuing through the production phase. Validation necessarily includes process qualification (the qualification of materials, equipment, systems, buildings, personnel), but it also includes the control on the entire process for repeated batches or runs.

The first drafts of the May 1987 *Guideline on General Principles of Process Validation* [3] contained a similar definition, which has frequently been used in FDA speeches since 1978, and is still used today: “A documented program which provides a high degree of assurance that a specific process will consistently produce a product meeting its pre-determined specifications and quality attributes.”

### **III. THE REGULATORY BASIS FOR PROCESS VALIDATION**

Once the concept of being able to predict process performance to meet user requirements evolved, FDA regulatory officials established that there was a legal basis for requiring process validation. The ultimate legal authority is Section 501(a)(2)(B) of the FD&C Act [4], which states that a drug is deemed to be adulterated if the methods used in, or the facilities or controls used for, its manufacture, processing, packing, or holding do not conform to or were not operated or administrated in conformity with CGMP. Assurance must be given that the drug would meet the requirements of the act as to safety and would have the identity and strength and meet the quality and purity characteristics that it purported or was represented to possess. That section of the act sets the premise for process validation requirements for both finished pharmaceuticals and active pharmaceutical ingredients, because active pharmaceutical ingredients are also deemed to be drugs under the act.

The CGMP regulations for finished pharmaceuticals, 21 CFR 210 and 211, were promulgated to enforce the requirements of the act. Although these regulations do not include a definition for process validation, the requirement is implicit in the language of 21 CFR 211.100 [5], which states: “There shall be written procedures for production and process control designed to assure that the drug products have the identity, strength, quality, and purity they purport or are represented to possess.”

### **IV. THE REGULATORY HISTORY OF PROCESS VALIDATION**

Although the emphasis on validation began in the late 1970s, the requirement has been around since at least the 1963 CGMP regulations for finished pharmaceuticals. The Kefauver-Harris Amendments to the FD&C Act were approved

in 1962 with Section 501(a)(2)(B) as an amendment. Prior to then, CGMP and process validation were not required by law. The FDA had the burden of proving that a drug was adulterated by collecting and analyzing samples. This was a significant regulatory burden and restricted the value of factory inspections of pharmaceutical manufacturers. It took injuries and deaths, mostly involving cross-contamination problems, to convince Congress and the FDA that a revision of the law was needed. The result was the Kefauver–Harris drug amendments, which provided the additional powerful regulatory tool that FDA required to deem a drug product adulterated if the manufacturing process was not acceptable. The first CGMP regulations, based largely on the Pharmaceutical Manufacturers Association’s manufacturing control guidelines, were then published and became effective in 1963. This change allowed FDA to expect a preventative approach rather than a reactive approach to quality control. Section 505(d)(3) is also important in the implementation of process validation requirements because it gives the agency the authority to withhold approval of a new drug application if the “methods used in, and the facilities and controls used for, the manufacture, processing, and packing of such drug are inadequate to preserve its identity, strength, quality, and purity.”

Another requirement of the same amendments was the requirement that FDA must inspect every drug manufacturing establishment at least once every 2 years [6]. At first, FDA did this with great diligence, but after the worst CGMP manufacturing situations had been dealt with and violations of the law became less obvious, FDA eased up its pharmaceutical plant inspection activities and turned its resources to more important problems.

The Drug Product Quality Assurance Program of the 1960s and 1970s involved first conducting a massive sampling and testing program of finished batches of particularly important drugs in terms of clinical significance and dollar volume, then taking legal action against violative batches and inspecting the manufacturers until they were proven to be in compliance. This approach was not entirely satisfactory because samples are not necessarily representative of all batches. Finished product testing for sterility, for example, does not assure that the lot is sterile. Several incidents refocused FDA’s attention to process inspections. The investigation of complaints of clinical failures of several products (including digoxin, digitoxin, prednisolone, and prednisone) by FDA found significant content uniformity problems that were the result of poorly controlled manufacturing processes. Also, two large-volume parenteral manufacturers experienced complaints despite quality control programs and negative sterility testing. Although the cause of the microbiological contamination was never proven, FDA inspections did find deficiencies in the manufacturing process and it became evident that there was no real proof that the products were sterile.

What became evident in these cases was that FDA had not looked at the process itself—certainly not the entire process—in its regulatory activities; it was quality control- rather than quality assurance-oriented. The compliance offi-

cials were not thinking in terms of process validation. One of the first entries into process validation was a 1974 paper presented by Ted Byers, entitled “Design for Quality” [7]. The term validation was not used, but the paper described an increased attention to adequacy of processes for the production of pharmaceuticals. Another paper—by Bernard Loftus before the Parenteral Drug Association in 1978 entitled “Validation and Stability” [8]—discussed the legal basis for the requirement that processes be validated.

The May 1987 *Guideline on General Principles of Process Validation* [3] was written for the pharmaceutical, device, and veterinary medicine industries. It has been effective in standardizing the approach by the different parts of the agency and in communicating that approach to manufacturers in each industry.

## V. UPDATE

As discussed in the preceding sections, process validation has been a legal requirement since at least 1963. Implementation of the requirement was a slow and deliberate process, beginning with the development and dissemination of an agency policy by Loftus, Byers, and others, and leading to the May 1987 guideline. The guideline quickly became an important source of information to pharmaceutical manufacturers interested in establishing a process validation program. Many industry organizations and officials promoted the requirements as well as the benefits of validation. Many publications, such as *Pharmaceutical Process Validation* [1] and various pharmaceutical industry journal articles, cited and often expanded on the principals in the guideline. During the same period, computer validation—or validation of computer controlled processes—also became a widely discussed topic in both seminars and industry publications.

The regulatory implementation of the validation requirement was also a deliberate process by FDA. During the 1980s, FDA investigators often reported processes that had not been validated or had been inadequately validated. Batch failures were often associated with unvalidated manufacturing processes. The FDA issued a number of regulatory letters to deficient manufacturers citing the lack of adequate process validation as a deviation from CGMP regulations (21CFR 211.100), which causes the drug product to be adulterated within the meaning of Section 501(a)(2)(B) of the federal FD&C Act. Process validation was seldom the only deficiency listed in these regulatory letters. The failure of some manufacturers to respond to these early warnings resulted in FDA filing several injunction cases that included this charge in the early 1990s. Most of these cases resulted in consent decrees, and ultimately the adoption of satisfactory process validation programs by the subject manufacturers. One injunction case filed in 1992, however, was contested in court and led to a lengthy written order and opinion by the U.S. District Court in February of 1993 [9]. The court

affirmed the requirement for process validation in the current good manufacturing regulations, and ordered the defendants to perform process validation studies on certain drug products, as well as equipment cleaning validation studies. This case and the court's ruling were widely circulated in the pharmaceutical industry and became the subject of numerous FDA and industry seminars.

The court also criticized the CGMP regulations for their lack of specificity, along with their ambiguity and vagueness. Responding to this criticism, FDA drafted revisions to several parts of these regulations. The proposed revisions were published in the *Federal Register* on May 3, 1996 [10]. One of the main proposed changes was intended to emphasize and clarify the process validation requirements. The proposal included a definition of process validation (the same definition used in the 1987 guideline), a specific requirement to validate manufacturing processes, and minimum requirements for performing and documenting a validation study. These were all implied but not specific in the 1978 regulation. In proposing these changes, FDA stated that it was codifying current expectations and current industry practice and did not intend to add new validation requirements. Comments from all interested parties were requested under the agency's rule-making policies, and approximately 1500 comments were received. Most of the responses to the changes regarding process validation supported the agency's proposals, but there were many comments regarding the definitions and terminology proposed about which processes and steps in a process should or should not require validation, the number of batches required for process validation, maintenance of validation records, and the assignment of responsibility for final approval of a validation study and change control decisions. Because of other high-priority obligations, the agency has not yet completed the evaluation of these responses and has not been able to publish the final rule. In addition to the official comments, the proposed changes prompted numerous industry and FDA seminars on the subject.

Process validation is not just an FDA or a U.S. requirement. Similar requirements are included in the World Health Organization (WHO), the Pharmaceutical Inspection Co-operation Scheme (PIC/S), and the European Union (EU) requirements, along with those of Australia, Canada, Japan, and other international authorities.

Most pharmaceutical manufacturers now put substantial resources into process validation for both regulatory and economic reasons, but despite continued educational efforts by both the agency and the pharmaceutical industry, FDA inspections (both domestically and internationally) continue to find some firms manufacturing drug products using unvalidated or inadequately validated processes. Evidently there is still room for improvement, and continued discussion, education, and occasional regulatory action appears warranted.

The future of process validation is also of great interest, especially with the worldwide expansion of pharmaceutical manufacturing and the desire for

harmonized international standards and requirements. Many manufacturers are also working on strategies to reduce the cost of process validation and incorporate validation consideration during product design and development. New technologies under development for 100% analysis of drug products and other innovations in the pharmaceutical industry may also have a significant effect on process validation concepts and how they can be implemented and regulated.

## REFERENCES

1. Loftus, B. T., Nash, R. A., ed. *Pharmaceutical Process Validation*. vol. 57. New York: Marcel Dekker (1993).
2. U.S. Food and Drug Administration. *Compliance Program no. 7356.002*.
3. U.S. Food and Drug Administration. *Guideline on General Principles of Process Validation*. Rockville, MD: FDA, 1987.
4. Federal Food Drug and Cosmetic Act, Title 21 U.S. Code, Section 501 (a)(2)(B).
5. Code of Federal Regulations, Title 21, Parts 210 & 211. *Fed Reg 43*, 1978.
6. U.S. Code, Federal Food Drug and Cosmetic Act, Title 21, Section 510 (h).
7. Byers, T. E. Design for quality, Manufacturing Controls Seminar, Proprietary Association, Cherry Hill, NJ, Oct. 11, 1974.
8. Loftus, B. T. Validation and stability, meeting of Parenteral Drug Association, 1978.
9. *U.S. v. Barr Laboratories, Inc.*, et al., Civil Action No. 92-1744, U.S. District Court for the District of New Jersey, 1973.
10. Code of Federal Regulations, Title 21, Parts 21 & 211, Proposed Revisions, *Fed Reg* (May 3, 1996).

# 2

## Prospective Process Validation

**Allen Y. Chao**

*Watson Labs, Carona, California, U.S.A.*

**F. St. John Forbes**

*Wyeth Labs, Pearl River, New York, U.S.A.*

**Reginald F. Johnson and Paul Von Doehren**

*Searle & Co., Inc., Skokie, Illinois, U.S.A.*

### I. INTRODUCTION

Validation is an essential procedure that demonstrates that a manufacturing process operating under defined standard conditions is capable of consistently producing a product that meets the established product specifications. In its proposed guidelines, the U.S. Food and Drug Administration (FDA) has offered the following definition for process validation [1].

Process validation is establishing documented evidence that provides a high degree of assurance that a specific process (such as the manufacture of pharmaceutical dosage forms) will consistently produce a product meeting its predetermined specifications and quality characteristics.

Many individuals tend to think of validation as a stand-alone item or an afterthought at the end of the entire product/process development sequence. Some believe that the process can be considered validated if the first two or three batches of product satisfy specifications.

Prospective validation is a requirement (Part 211), and therefore it makes validation an integral part of a carefully planned, logical product/process developmental program. An outline of the development sequence and requirements relevant to process validation is presented in [Figure 1](#). After briefly discussing organizational aspects and documentation, the integration of validation into the product development sequence is discussed. At the end of the chapter there is a

brief discussion of specific ways in which experimental programs can be defined to ensure that critical process development and validation objectives are met.

## **II. ORGANIZATION**

Prospective validation requires a planned program and organization to carry it to successful completion. The organization must have clearly defined areas of responsibility and authority for each of the groups involved in the program so that the objective of validating the process can be met. The structure must be tailored to meet the requirements in the specific organization, and these will vary from company to company. The important point is that a defined structure exists, is accepted, and is in operation. An effective project management structure will have to be established in order to plan, execute, and control the program. Without clearly defined responsibilities and authority, the outcome of process validation efforts may not be adequate and may not comply with CGMP requirements.

## **III. MASTER DOCUMENTATION**

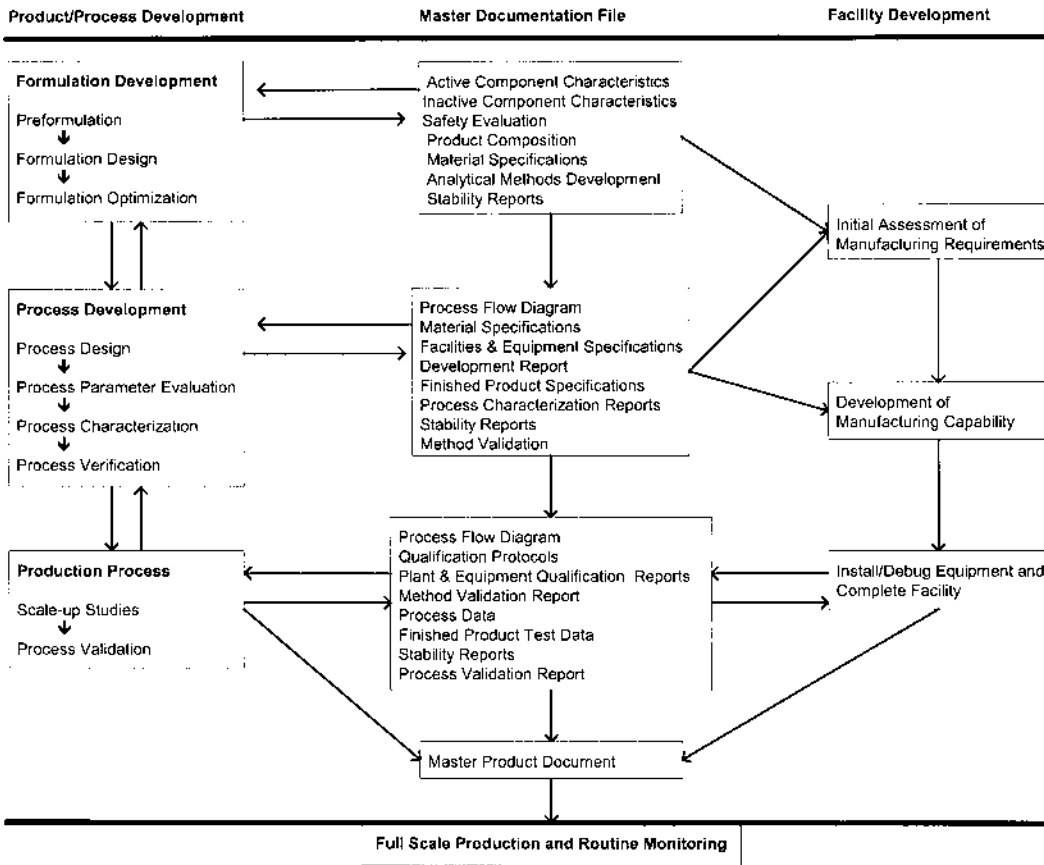
An effective prospective validation program must be supported by documentation extending from product initiation to full-scale production. The complete documentation package can be referred to as the master documentation file.

It will accumulate as a product concept progresses to the point of being placed in full-scale production, providing as complete a product history as possible. The final package will be the work of many individual groups within the organization. It will consist of reports, procedures, protocols, specifications, analytical methods, and any other critical documents pertaining to the formulation, process, and analytical method development. The package may contain the actual reports, or it may utilize cross-references to formal documentation, both internal and external to the organization.

The ideal documentation package will contain a complete history of the final product that is being manufactured. In retrospect, it would be possible to trace the justification or rationale behind all aspects of the final product, process, and testing.

The complete master documentation file not only provides appropriate rationale for the product, process, and testing, but also becomes the reference source for all questions relating to the manufacture of a product at any plant location. This master documentation file, however, should not be confused with the concept of the master product document, which is essential for routine manufacturing of the product and is described later in the chapter. The master docu-





**Figure 1** Prospective process validation.

mentation file should contain all information that was generated during the entire product development sequence to a validation process.

## **IV. PRODUCT DEVELOPMENT**

Product development usually begins when an active chemical entity has been shown to possess the necessary attributes for a commercial product. The product development activities for the active chemical entity, formulation, and process form the foundation upon which the subsequent validation data are built.

Generally, product development activities can be subdivided into formulation and process development, along with scale-up development.

### **A. Formulation Development**

Formulation development provides the basic information on the active chemical, the formula, and the impact of raw materials or excipients on the product. Typical supportive data generated during these activities may include the following:

1. Preformulation profile or characterization of the components of the formula, which includes all the basic physical or chemical information about the active pharmaceutical ingredients (API, or the chemical entity) and excipients
2. Formulation profile, which consists of physical and chemical characteristics required for the products, drug-excipient compatibility studies, and the effect of formulation on in vitro dissolution
3. Effect of formulation variables on the bioavailability of the product
4. Specific test methods
5. Key product attributes and/or specifications
6. Optimum formulation
7. Development of cleaning procedures and test methods

Formulation development should not be considered complete until all those factors that could significantly alter the formulation have been studied. Subsequent minor changes to the formulation, however, may be acceptable, provided they are thoroughly tested and are shown to have no adverse effect on product.

### **B. Process Development**

Even though the process development activities typically begin after the formulation has been developed, they may also occur simultaneously. The majority of the process development activities occur either in the pilot plant or in the pro-

posed manufacturing plant. The process development program should meet the following objectives:

1. Develop a suitable process to produce a product that meets all
  - a. Product specifications
  - b. Economic constraints
  - c. Current good manufacturing practices (CGMPs)
2. Identify the key process parameters that affect the product attributes
3. Identify in-process specifications and test methods
4. Identify generic and/or specific equipment that may be required

It is important to remember that cleaning procedures should at least be in the final stages of development, as equipment and facilities in the pilot or proposed manufacturing plant are involved, and the development of the cleaning verification test methods must be complete.

Process development can be divided into several stages.

Design

Challenging of critical process parameters

Verification of the developed process

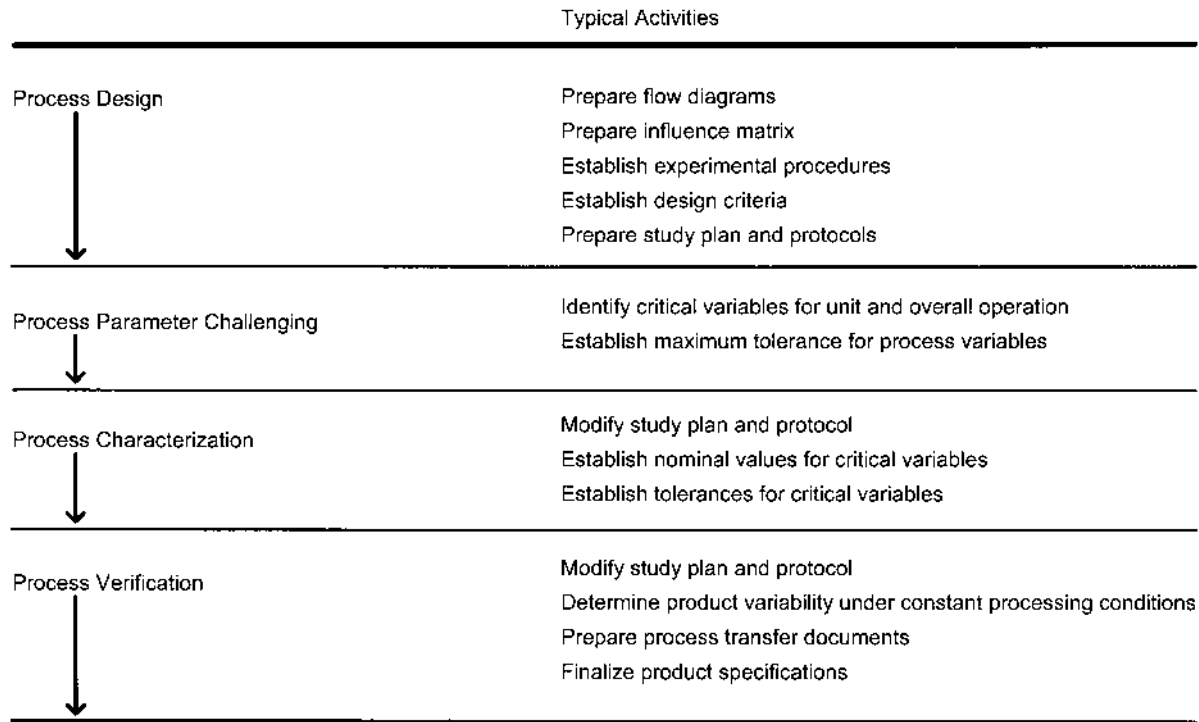
Typical activities in these areas are illustrated in [Figure 2](#).

## 1. Design

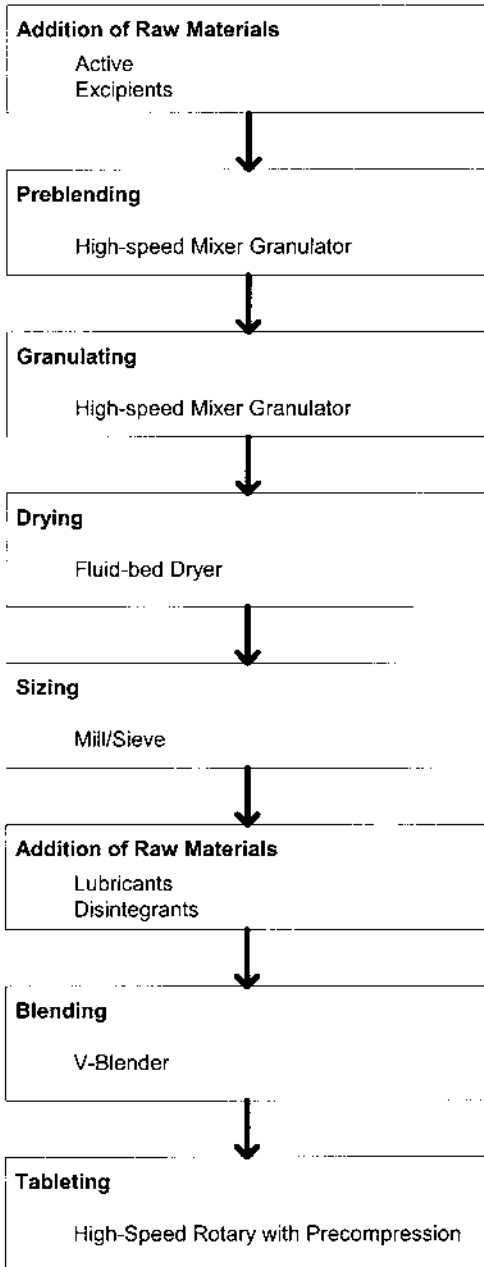
This is the initial planning stage of process development. The design of the process should start during or at the end of the formulation development to define the process to a large extent. One aspect of the process development to remember is end user (manufacturing site) capabilities. In other words, the practicality and the reality of the manufacturing operation should be kept in perspective. Process must be developed in such a manner that it can easily be transferred to the manufacturing site with minimal issues. During this stage, technical operations in both the manufacturing and quality control departments should be consulted.

Key documents for the technical definition of the process are the flow diagram, the cause-and-effect diagram, and the influence matrix. The details of the cause-and-effect diagram and the influence matrix will be discussed under experimental approach in a later section.

The flow diagram identifies all the unit operations, the equipment used, and the stages at which the various raw materials are added. The flow diagram in [Figure 3](#) outlines the sequence of process steps and specific equipment to be used during development for a typical granulation solid dosage form product. The flow diagram provides a convenient basis on which to develop a detailed list of variables and responses.



**Figure 2** Product development flow.



**Figure 3** Typical process flow—granulated product.

Preliminary working documents are critical, but they should never be cast in stone, since new experimental data may drastically alter them. The final version will eventually be an essential part of the process characterization and technical transfer documents.

Regardless of the stage of formulation/process development being considered, a detailed identification of variables and responses is necessary for early program planning. Typical variables and responses that could be expected in a granulated solid dosage form are listed in Table 1. This list is by no means complete and is intended only as an example.

**Table 1** Typical Variables and Responses: Granulated Product

Process step	Control variables	Measured responses
Preblending	Blending time rpm Load size Order of addition	Blend uniformity
Granulating	Load size Amount of granulating agent Solvent addition rate rpm Granulation time	Density Yield
Drying	Initial temperature Load size Drying temperature program Air flow program Drying time Cooling time	Density Moisture content Yield
Sizing	Screen type Screen size Feed rate	Granule size distribution Loose density Packed density
Blending	Load size rpm Blending time	Blend uniformity Flow characteristics Particle size distribution
Tableting	Compression rate Granule feed rate Precompression force Compression force	Weight variation Friability Hardness Thickness Disintegration time Dissolution Dosage form uniformity

As the developmental program progresses, new discoveries will provide an update of the variables and responses. It is important that current knowledge be adequately summarized for the particular process being considered. It should be pointed out, however, that common sense and experience must be used in evaluating the variables during process design and development. An early transfer of the preliminary documentation to the manufacturing and quality control departments is essential, so that they can begin to prepare for any new equipment or facilities that may be required.

## 2. Challenging of Process Parameters

Challenging of process parameters (also called process ranging) will test whether or not all of the identified process parameters are critical to the product and process being developed. These studies determine:

- The feasibility of the designed process
- The criticality of the parameters

This is usually a transition stage between the laboratory and the projected final process. [Figure 4](#) also shows typical responses that may have to be evaluated during the ranging studies on the tableted product.

## 3. Challenging of Critical Process Parameters or Characterization of the Process

Process characterization provides a systematic examination of critical variables found during process ranging. The objectives of these studies are

- Confirm critical process parameters and determine their effects on product quality attributes.
- Establish process conditions for each unit operation.
- Determine in-process operating limits to guarantee acceptable finished product and yield.
- Confirm the validity of the test methods.

A carefully planned and coordinated experimental program is essential in order to achieve each of these objectives. Techniques to assist in defining experimental programs are mentioned later in the chapter.

The information summarized in the process characterization report provides a basis for defining the full-scale process.

## 4. Verification

Verification is required before a process is scaled up and transferred to production. The timing of this verification may be critical from a regulatory point of view, as there is little or no room for modifying the parameter values and

specifications, particularly shifting or expanding after the regulatory submission is made. This ensures that it behaves as designed under simulated production conditions and determines its reproducibility. Key elements of the process verification runs should be evaluated using a well-designed in-process sampling procedure. These should be focused on potentially critical unit operations. Validated in-process and final-product analytical procedures should always be used. Sufficient replicate batches should be produced to determine between- and within-batch variations.

Testing during these verification runs will be more frequent and cover more variables than would be typical during routine production. Typically the testing requirements at the verification stage should be the same or more than the proposed testing for process validation runs. The typical process verification analysis of tabulated product includes the following:

Unit operation	Analysis
Preblending	Potency (if required)
Granulation	Potency (if required)
Sizing	Particle size distribution Loss on drying (LOD)
Blending	Uniformity Particle size distribution
Tableting	Weight Hardness Thickness Disintegration and/or dissolution Friability Potency Dosage uniformity Degradants

For maximum information, the process should not be altered during the verification trials.

## 5. Development Documentation

The developmental documentation to support the validation of the process may contain the following:

- Process challenging and characterization reports that contain a full description of the studies performed
- Development batch record
- Raw material test methods and specifications



- Equipment list and qualification and calibration status
- Process flow diagram
- Process variable tolerances
- Operating instructions for equipment (where necessary)
- In-process quality control program, including:
  - Sampling intervals
  - Test methods
  - Finished Product
  - Stability
- Critical unit operation
- Final product specifications
- Safety evaluation
- Chemical
  - Process
- Special production facility requirements
- Cleaning
  - Procedure for equipment and facilities
  - Test methods
- Stability profile of the product
  - Produced during process development
  - Primary packaging specification

## **V. DEVELOPMENT OF MANUFACTURING CAPABILITY**

There must be a suitable production facility for every manufacturing process that is developed. This facility includes buildings, equipment, staff, and supporting functions.

As development activities progress and the process becomes more clearly defined, there must be a parallel assessment of the capability to manufacture the product. The scope and timing of the development of manufacturing capability will be dependent on the process and the need to utilize or modify existing facilities or establish new ones.

## **VI. FULL-SCALE PRODUCT/PROCESS DEVELOPMENT**

The development of the final full-scale production process proceeds through the following steps:

- Process scale-up studies
- Qualification trials
- Process validation runs

## **A. Scale-Up Studies**

The transition from a successful pilot-scale process or research scale to a full-scale process requires careful planning and implementation. Although a large amount of information has been gathered during the development of the process (i.e., process characterization and process verification studies), it does not necessarily follow that the full-scale process can be completely predicted.

Many scale-up parameters are nonlinear. In fact, scale-up factors can be quite complex and difficult to predict, based only on experience with smaller-scale equipment. In general, the more complex the process, the more complex the scale-up effect.

For some processes, the transition from pilot scale or research scale to full scale is relatively easy and orderly. For others the transition is less predictable. More often than not there will be no serious surprises, but this cannot be guaranteed. Individuals conducting the transfer into production should be thoroughly qualified on both small- and large-scale equipment.

The planning for scale-up should follow the same general outline followed for process characterization and verification. It usually begins when process development studies in the laboratory have successfully shown that a product can be produced within specification limits for defined ranges of process parameters.

Frequently, because of economic constraints, a carefully selected excipient may be used as a substitute for the expensive active chemical in conducting initial scale-up studies. Eventually, the active chemical will have to be used to complete the scale-up studies, however.

It is common sense that every effort will be made to conduct the final scale-up studies under CGMP conditions, thus any product produced with specifications can be considered for release as a finished salable product (for over-the-counter products only).

## **B. Qualification Trials**

Once the scale-up studies have been completed, it may be necessary to manufacture one or more batches at full scale to confirm that the entire manufacturing process, comprising several different unit operations, can be carried out smoothly. This may occur prior to or after the regulatory submission, depending on the strategy used in filing.

## **C. Process Validation Runs**

After the qualification trials have been completed, the protocol for the full-scale process validation runs can be written. Current industry standard for the validation batches is to attempt to manufacture them at target values for both process

parameters and specifications. The validation protocol is usually the joint effort of the following groups:

- Research and development
- Pharmaceutical technology or technical services
- Quality control (quality assurance)
- Manufacturing
- Engineering

One of these groups usually coordinates the activities.

A complete qualification protocol will contain specific sections; however, there can be considerable variation in individual protocol. Section content typical validation protocol may consist of the following:

- Safety instructions
- Environmental restrictions
  - Gas or liquid discharge limitations
  - Solid or scrap disposal instructions
- Equipment
  - Description
  - Operation
  - Cleaning
- Raw materials
  - Pertinent characteristics
  - Acceptance limits
  - Analytical methods
  - Packaging and storage
  - Handling precautions
- Process flow chart
- Critical parameters and related means of controls
- Responsibilities of each of the groups participating
- Cleaning validation/verification requirements
- Master batch components (percentage by weight)
- Production batch component (by weight)
- Process batch record
  - Process sequence
  - Process instructions
  - Material usage
- Product testing
  - In-process testing and acceptance criteria
  - Finished product testing and acceptance criteria
  - Test method references
- Formulation

- Validation sampling and testing
  - In-process
  - Finished product
- Definition of validation criteria
  - Lower and upper acceptance limits
  - Acceptable variation
  - Cleaning sampling plan (locations, type, and number of samples)

It is expected that acceptable, salable products will be produced, since all qualification batches will be produced using a defined process under CGMP conditions with production personnel.

A question that always arises is how many replicate batches or lots must be produced for a validation protocol to be valid or correct. There is no absolute answer. Obviously, a single batch will provide the minimum amount of data. As the number of replicated batches increases, the information increases. The FDA, however, has determined that the minimum number of validation batches should be three.

#### **D. Master Product Document**

An extensive quantity of documents is generated at each stage of the development and validation of the final production process. Some of these documents will be directly related to the manufacture of the final products. Others may provide the basis for decisions that ultimately result in the final process.

The documents that are required for manufacturing the product then become the master product document. This document must be capable of providing all of the information necessary to set up the process to produce a product consistently and one that meets specifications in any location.

Items that will normally be included in the master product document are

- Batch manufacturing record
- Master formulation
- Process flow diagram
- Master manufacturing instructions
- Master packaging instructions
- Specifications
- Sampling (location and frequency)
- Test methods
- Process validation data

Each of the above items must contain sufficient detailed information to permit the complete master product document to become an independent, single package that will provide all information necessary to set up and produce a product.

## VII. DEFINING EXPERIMENTAL PROGRAMS

The objective in this section is to examine experiments or combinations of related experiments that make up development programs so that adequate justification can be developed for the formulation, process, and specifications. The emphasis will be on techniques to increase developmental program effectiveness.

A logical and systematic approach to each experimental situation is essential. Any experiment that is performed without first defining a logical approach is certain to waste resources. The right balance between overplanning and underplanning should always be sought.

It is usually impossible to define a substantial experimental effort at the beginning and then execute it in every detail without modification. To overcome this, it is convenient to split the program into a number of stages.

Each stage will normally consist of several specific experiments. The earlier experiments tend to supply initial data concerning the process and define preliminary operating ranges for important variables. As results become available from each stage, they can be used to assist in defining subsequent stages in the experimental program. In some cases it may be necessary to redefine completely the remainder of the experimental program on the basis of earlier results.

The following discussion describes some techniques to help improve experimental program effectiveness. A logical and systematic approach coupled with effective communication among individuals associated with the program is emphasized. Topics to be discussed include

- Defining program scope
- Process summary
- Experimental design and analysis
- Experiment documentation
- Program organization

### A. Program Scope

Defining a clear and detailed set of objectives is a necessary first step in any experimental program. Some similarity exists between objectives for different products and processes using similar existing technology. For products and processes at the forefront of technology, the definition of specific experimental objectives can be a continuing activity throughout product development.

Constraints on planning experimental programs can be classified according to their impact on time, resources, and budget. The effect and impact of these should be incorporated into the experimental program early to avoid compromising critical program objectives.

## B. Process Summary

An initial clear understanding of the formulation and/or process is important. The following techniques can assist in summarizing current process knowledge.

### 1. Flow Diagram

A process flow diagram (Fig. 3) can often provide a focal point of early program planning activities. This diagram outlines the sequence of process steps and specific equipment to be used during development for a typical granulated product. Flow diagram complexity will depend on the particular product and process. The flow diagram provides a convenient basis on which to develop a detailed list of variables and responses.

### 2. Variables and Responses

For process using existing technology, many of the potential variables and responses may have already been identified in previous product-development studies or in the pharmaceutical literature. Once properly identified, the list of variables and responses for the process is not likely to change appreciably. Typical variables and responses that could be expected in a granulated solid dosage form are listed in Table 1.

In addition, the relative importance of variables and responses already identified will likely shift during development activities.

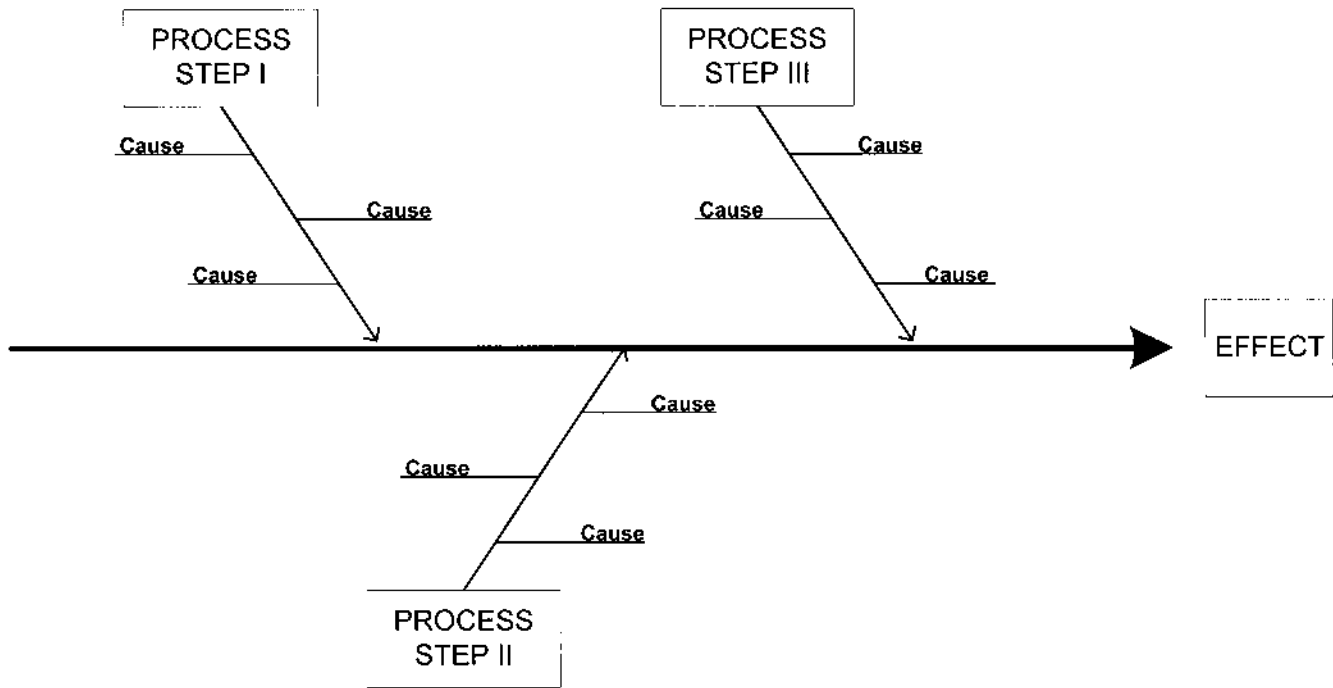
### 3. Cause-and-Effect Diagram

An efficient representation of complex relationships between many process and formulation variables (causes), and a single response (effect) can be shown by using a cause-and-effect diagram [1]. Figure 4 is a simple example.

A central arrow in Figure 4 points to a particular single effect. Branches off the central arrow lead to boxes representing specific process steps. Next, principle factors of each process step that can cause or influence the effect are drawn as subbranches of each branch, until a complete cause-and-effect diagram is developed. This should be as detailed a summary as possible. An example of a more complex cause-and-effect diagram is illustrated in Figure 5. A separate summary for each critical product characteristic (e.g., weight variation, dissolution, friability) should be made.

### 4. Influence Matrix

Once the variables and responses have been identified, it is useful to summarize their relationships in an influence matrix format, as shown in Figure 6. Based on the available knowledge, each process variable is evaluated for its potential



**Figure 4** Simple cause-and-effect diagram.

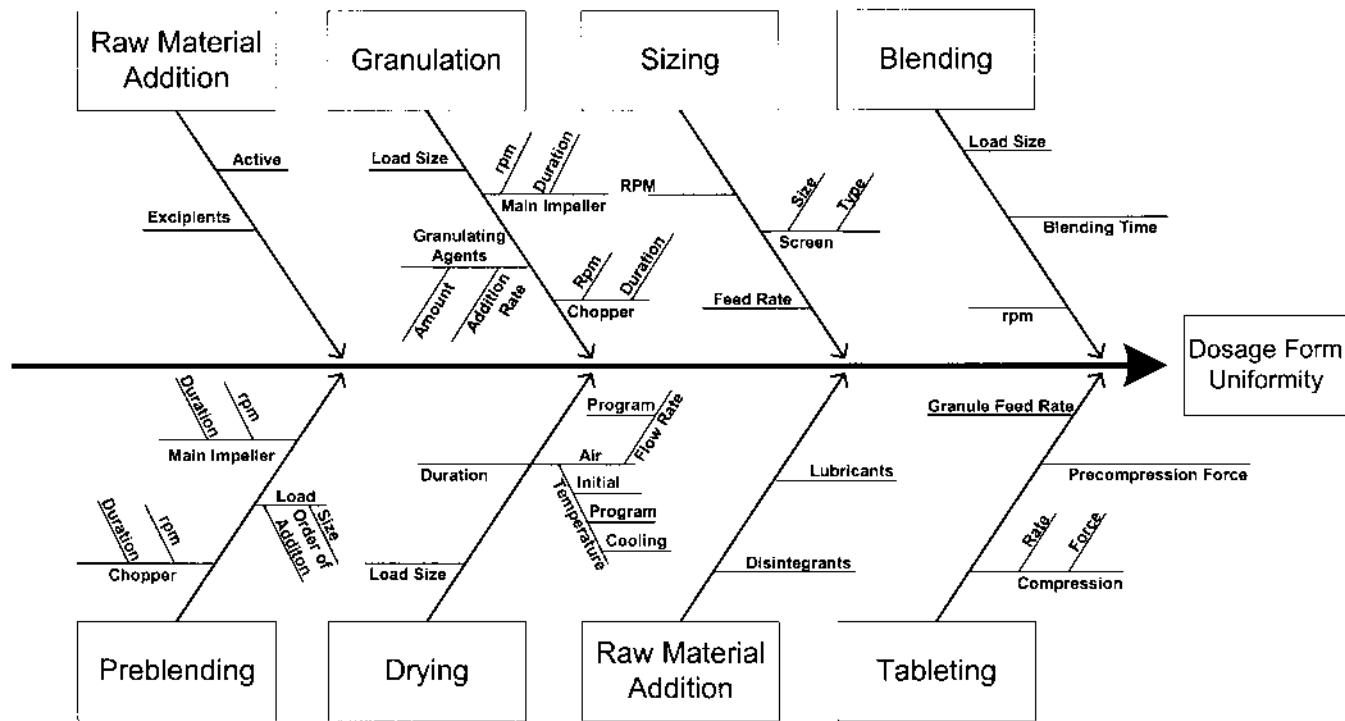


Figure 5 Cause-and-effect diagram (granulated product).



Process Variables		In-process / Final Product Characteristics							
		Preblend Uniformity	Power Load	Moisture Content	Granule Size Distribution	Blend Uniformity	Hardness	Friability	Dosage Form Uniformity
Preblending	rpm	S	/	/	N	W	N	N	W
	Time	S	/	/	N	W	N	N	W
Granulating	rpm	/	S	N	W	W	W	N	W
	Amount of Solvent	/	M	W	M	W	W	W	W
	Time	/	M	N	M	W	W	W	W
Drying	Temperature Program	/	/	S	/	N	N	N	N
	Time	/	/	S	M	N	N	N	N
Sizing	Screen Size	/	/	/	S	W	N	M	W
Tableting	Time	/	/	/	/	S	M	N	S
Blending	Compression Rate	/	/	/	/	/	W	W	W
	Compression Force	/	/	/	/	/	S	S	W

**Figure 6** Influence matrix for variables and responses (simplified).

effects on each of the process responses or product characteristics. The strength of the relationship between variables and responses can be indicated by some appropriate notation, such as strong (S), moderate (M), weak (W), or none (N), together with special classifications such as unknown (?).

Construction of the influence matrix assists in identifying those variables with the greatest influence on key process or product characteristics. These variables are potentially the most critical for maintaining process control and should be included in the earliest experiments. Some may continue to be investigated during development and scale-up.

## **VIII. EXPERIMENTAL DESIGN AND ANALYSIS**

Many different experimental designs and analysis methods can be used in development activities (Fig. 7). Indeed, the possibilities could fill several books. Fortunately, in any given situation, it is not necessary to search for that single design or analysis method that absolutely must be used; there are usually many possibilities. In general, designs that are usable offer different levels of efficiency, complexity, and effectiveness in achieving experimental objectives.

### **A. Types of Design**

It is not possible to list specific designs that will always be appropriate for general occasions. Any attempt to do so would be sure to be ineffective, and the uniqueness of individual experimental situation carefully, including

- Specific objectives
- Available resources
- Availability of previous theoretical results
- Relevant variables and responses
- Qualifications and experience of research team members
- Cost of experimentation

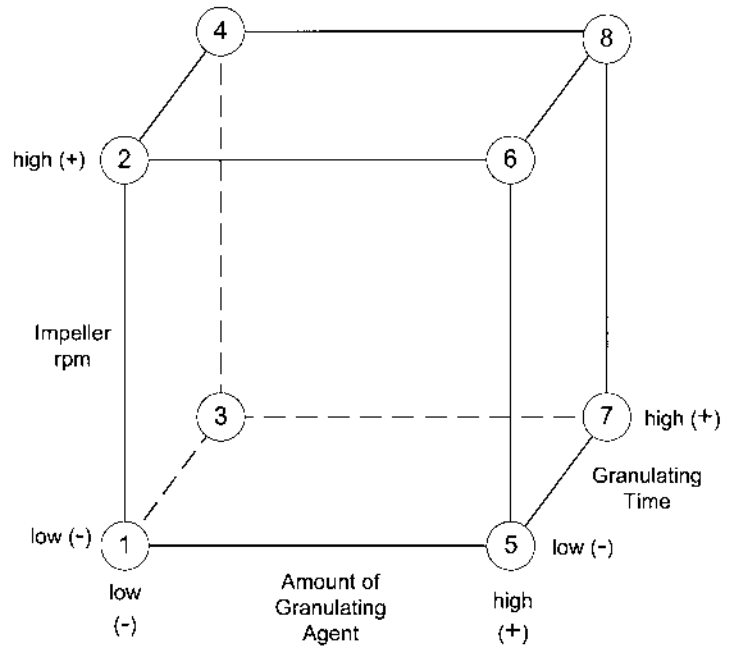
It should also be determined which design is appropriate. A statistician who is experienced in development applications can assist in suggesting and evaluating candidate designs. In some cases, the statistician should be a full-time member of the research team.

### **B. Data Analysis**

The appropriate analysis of the experimental results will depend on the experimental objectives, the design used, and the characteristics of the data collected during the experiment. In many cases, a simple examination of a tabular or

### Experimental Conditions

Condition	Amount of Granulating Agent	Granulating Time	Impeller rpm
1	-	-	-
2	-	-	+
3	-	+	-
4	-	+	+
5	+	-	-
6	+	-	+
7	+	+	-
8	+	+	+



**Figure 7** Experimental design example.

graphical presentation of the data will be sufficient. In other cases, a formal statistical analysis may be required in order to draw any conclusions at all. It depends on the particular experimental situation. No rules of thumb are available. In general, the simplest analysis consistent with experimental objectives and conditions is the most appropriate.

### **C. Experiment Documentation**

Documentation is essential to program planning and coordination, in addition to the obvious use for the summary of activities and results. Written communication becomes important for larger complex programs, especially when conducted under severe constraints on time and resources. Documentation can consist of some or all of the following items:

1. Objectives; an exact statement of quantifiable results expected from the experiment
2. Experimental design; a detailed list of the experimental conditions to be studied and the order of investigation
3. Proposed/alternate test methods
  - a. A list of test methods consistent with the type of experiment being performed
  - b. A detailed description of the steps necessary to obtain a valid measurement
  - c. Documentation supporting the accuracy, precision, sensitivity, and so on of the test methods
4. Equipment procedures; documentation of safety precautions and step-by-step methods for equipment setup, operation, and cleanup
5. Sampling plans; the type, number, location, and purpose of samples to be taken during the experiment; in addition, the type and number of all measurements to be performed on each sample
6. Protocol; a formal written experimental plan that presents the aforementioned experimental documentation in a manner suitable for review
7. Data records
  - a. Experiment log; details of events in the experiment noting process adjustments and any unusual occurrences
  - b. In-process measurements; records of the magnitude of critical process parameters during the experimental sequence  
Sample measurements; recorded values of particular measurements on each sample
8. Report; documentation of experiment implementation, exceptions/modifications to the protocol, results, and conclusion

## D. Program Organization

Throughout the experimental phases of the development program, it is essential to maintain effective communication among various team members. This is facilitated by having one individual with the necessary technical and managerial skills assume responsibility for the experimental program, including procuring resources and informing management of progress.

In a large experimental program, the responsible individual may serve as a project leader or manager with little or no technical involvement.

## IX. SUMMARY

Prospective validation of a production process utilizes information generated during the entire development sequence that produced the final process.

Validation is supported by all phases of development from the product concept.

As a potential product moves through the various developmental stages, information is continually generated and incorporated into a master documentation file. When the validation runs are planned for the final process, they will be based on the master documentation file contents. The information generated during the validation runs is usually the last major item to go into the master documentation file.

An abstract of the master documentation file is the master product document, which is the source of all information required to set up the process at any location.

Though validation may seem to be a stand-alone item, it actually is an integral portion of the entire product/process development sequence.

## REFERENCES

1. FDA. *Guidelines on General Principles of Process Validation*. Rockville, MD: Division of Manufacturing and Product Quality (HFN-320) Center for Drugs and Biologics (May 1987).
2. Box, G. E. P., Gunter, W. G., and Hunter, J. S. *Statistics for Experimenters: An Introduction to Design, Data Analysis, and Model Building*. New York: Wiley (1978).
3. Box, G. E. P., and Draper, N. R. *Evolutionary Operation: A Statistical Method for Process Improvement*. New York: Wiley (1969).
4. Cornell, J. A. *Experiments with Mixtures: Design, Models and the Analysis of Mixture Data*. New York: Wiley (1981).
5. Daniel, C. *Applications of Statistics to Industrial Experiments*. New York: Wiley (1976).

6. Davies, O. L., ed. *The Design and Analysis of Industrial Experiments*. New York: Longman Group (1978).
7. Diamond, W. J. *Practical Experiment Designs for Engineers and Scientists*. Belmont, CA: Lifetime Learning Publications (1981).
8. Ott, E. R. *Process Quality Control: Troubleshooting and Interpretation of Data*. New York: McGraw-Hill (1975).
9. Anderson, N. R., Banker, G. S., and Peck, G. E. *Pharmaceutical Dosage Forms: Tablets*. vol. III. New York: Marcel Dekker (1981).

# 3

## Retrospective Validation

**Chester J. Trubinski**

*Church & Dwight Co., Inc., Princeton, New Jersey, U.S.A.*

### I. INTRODUCTION

In the present-day pharmaceutical industry the Food and Drug Administration (FDA) expects firms to have validated manufacturing processes. Process validation has been defined as a documented program that provides a high degree of assurance that a specific process will consistently produce a product meeting predetermined specifications [1]. For new products or existing products that have recently undergone reformulation, validation is usually an integral part of the process development effort. No such opportunity exists for older established products, however. Of the brands recognized as medical or scientific breakthroughs of the 20th century that continue to be marketed, 21 were introduced before 1980 [2]. This suggests product lines are likely to contain a product for which the manufacturing processes have not been validated, at least not to the extent that is now expected.

### II. PROCESS VALIDATION STRATEGIES

The FDA has published a guideline for use by industry that outlines general principles considered acceptable parts of process validation [1]. Pharmaceutical firms have been inspected against this standard and those found wanting have been cited or had approval to manufacture product denied. Indeed, statistics compiled by the FDA for fiscal year 1997 show inadequate process validation as one of the top 10 reasons for withholding approval [3]. One way for a firm to satisfy the requirement for validated processes is to identify those products that have been on the market for some time and use the wealth of production,

testing, and control data to demonstrate that the process is reliable. This strategy is commonly referred to as retrospective validation. Historical data also may be used to augment an earlier validation in cases in which the product has changed.

### **A. Product Selection Criteria for Retrospective Validation**

For a product to be considered for retrospective validation, it must have a stable process; that is, one in which the method of manufacture has remained essentially unchanged for a period of time.

The first step in the product selection process is therefore to obtain a summary of changes in the method of manufacture. In most companies such information is part of the master batch record file. Then a time interval is selected that represents the last 20 to 30 batches. Products for which there is no record of a change in the method of manufacture or control during this period can be regarded as candidates for validation. The 20-to-30-batch rule originates from control chart principals, which consider 20 to 30 points that plot within the limits as evidence of a stable process [4]. Once this criterion is met, the number selected is actually somewhat arbitrary, as there is no one number that is correct for every product. The ideal number of batches required to study a product is theoretically the number that permits all process variables to come into play. By process variables, we mean raw materials from different but approved vendors, introduction of similar but different pieces of equipment, personnel and seasonal changes, and the like. This academic approach may present a rather unwieldy situation, especially for a high-volume product, for which change in process variables occurs infrequently. The influence of seasonal changes is such an example. In such instances, compromise will need to be reached between process variables included for study and the number of batches that can be examined for data. This decision making is best handled by a validation committee, the organization and makeup of which is covered in detail later in this chapter.

The second step in the product selection process addresses the situation in which a change in the method of manufacture or control was implemented during the last 20 or so production batches. The fact that a change has occurred does not automatically disqualify the product for retrospective validation. One must first know whether the particular modification has caused an expected result to be different to the extent that it is no longer comparable to previous batches. An example may be helpful. Suppose the method of granulating was changed midway through the series of 20 batches selected for the validation study. The number of batches representing the new process would be significantly reduced and could be insufficient to capture some of the interactions that can affect process reproducibility. In general, a history of any one of the follow-



ing changes to the method of manufacture and control should be fully investigated before any decision is made to validate retrospectively:

1. Formulation changes involving one or more of the active ingredients or key excipients
2. Introduction of new equipment not equivalent in every respect to that previously in use
3. Changes in the method of manufacture that may affect the product's characteristics
4. Changes to the manufacturing facility

A product found to be unsuitable for retrospective validation because of a revised manufacturing process is a likely candidate for prospective validation, which is beyond the scope of this chapter [1]. Such a discovery, however, should be brought to the attention of the appropriate authority. In today's regulatory environment ignoring the matter would be imprudent.

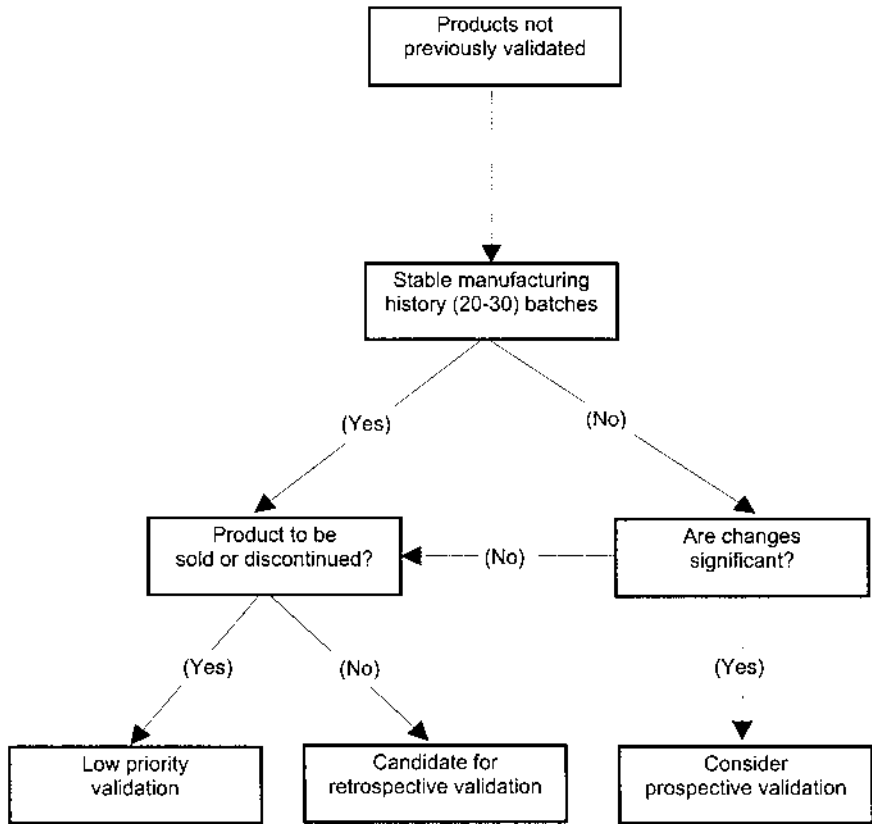
The third and last step in our selection process is to identify which products are likely to be discontinued because of a lack of marketing interest or regulatory consideration, to be sold, or to be reformulated. The timing of these events will dictate whether the product in question remains a viable candidate for retrospective validation.

The foremost discussion on developing a list of suitable products for study is summarized in [Figure 1](#).

## **B. Organizing for Retrospective Validation**

To this point we have produced a list of products that may be validated retrospectively; that is, their manufacturing processes are relatively stable, and so adequate historical data exist on which to base an opinion. The next consideration is the formal mechanism for validating the individual products. Appropriate organizational structures for effectively validating processes have been put forth, but mostly in conjunction with the validation of new product introductions. Still, these recommendations can serve as models. Because the products being studied are marketed products, the quality assurance and production departments can be expected to make major contributions. In fact, as far as retrospective validation is concerned, it may be more appropriate for one of these departments to coordinate the project. The research and engineering departments, of course, will be needed, especially where recent process changes have been encountered or equipment design is at issue.

Operating as a team, the previously discussed disciplines will determine which data should be collected for each product and from how many batches; subsequently, they will evaluate the information and report their findings. Personnel resources beyond this committee are necessary to accomplish the tasks



**Figure 1** Selection of candidates for retrospective validation.

of data collection and analysis. The time requirements dictate that such work be assigned to a function with discretionary time, possibly a technical services group or a quality engineer. Management commitment is especially crucial if disruptive influences are to be minimized. The loss of a committee member to another project is such an example.

### C. Written Operating Procedures

The various activities and responsibilities associated with retrospectively validating a product must be put in writing. All too often this simple but crucial step is omitted for the sake of expediency only to find at a later date that the

initial assumptions cannot be recalled. Aside from maintaining consistency, a written procedure to describe the work being performed satisfies the intent of the current good manufacturing practice (CGMP) regulations.

In general, the written operating procedure should delineate in reasonable detail how the validation organization will function. Not every situation can be anticipated, and this should not be the goal. There should be sufficient detail, however, to ensure consistency of performance in an undertaking that may continue for several months. In the preparation of such a document, the following questions should be answered:

1. Which organizational functions will be represented on the validation committee?
2. What mechanism exists for validation protocol preparation and approval?
3. What criteria are used to select critical process steps and quality control tests for which data will be collected?
4. How often will the committee meet to ensure prompt evaluation of study data?
5. Who has responsibility for documenting committee decisions? For report preparation?
6. Is there a provision for follow-up in the event of unexpected findings?
7. Where will the original study data and reports be archived?

In the preceding discussion of areas of interest to the validation organization, two concepts were introduced that deserve further clarification: (1) critical process steps and quality control tests that characterize the operation, and (2) validation protocol.

## 1. Critical Process Steps and Control Tests

Critical process steps are operations performed during dosage-form manufacture that can contribute to variability of the end product if not controlled. Since each type of dosage form requires different machinery and unit operations to produce the end product, the critical process steps will also differ. For each product considered suitable for retrospective validation, a list of these steps must be compiled following careful analysis of the process by technically competent persons. In a similar manner, in-process and finished-product tests should be screened to identify those that may be of some value. As a rule, tests in that the outcome is quantitative will be of greatest interest.

A flow diagram of the entire operation, but particularly of the manufacturing process, may be helpful in identifying critical steps, especially where the process involves many steps. Such a diagram is also a useful addition to the validation report prepared at the conclusion of the study.

## 2. Validation Protocol

A written protocol that describes what is to be accomplished should be prepared [5]. It should specify the data to be collected, the number of batches to be included in the study, and how the data, once assembled, will be treated for relevance. The criteria for acceptable results should be described. The date of approval of the protocol by the validation organization should also be noted. The value of a protocol is to control the direction of the study, as well as provide a baseline in the event unanticipated developments necessitate a change in strategy. A written protocol is also an FDA recommendation [1].

### D. Other Considerations

Comprehensive records of complaints received either directly from the customer or through a drug problem reporting program should be reviewed. Furthermore, a record of any follow-up investigation of such complaints is mandatory [6] and should be part of this file. Review of customer complaint records can furnish a useful overview of process performance and possibly hint at product problems. Complaint analysis should therefore be viewed as a meaningful adjunct to the critical process step and control test selection process.

Batch yield reflects efficiency of the operation. Because yield figures are the sum of numerous interactions, they fail in most cases to provide specific information about process performance and therefore must be used with caution in retrospective validation. In any event, this information should be collected, as it can contribute to further refinement of the yield limits that appear in the batch record.

Lot-to-lot differences in the purity of the therapeutic agent must be considered when evaluating in-process and finished-product test results. In addition to potency such qualities as particle size distribution, bulk density, and source of the material will be of interest. Such information should be available from the raw material test reports prepared by the quality control laboratory for each lot of material received. The physical characteristics of the excipients should not be overlooked, especially for those materials with inherent variability. Metallic stearates is a classic example. In such instances, the source of supply is desirable information to have available.

There is value in examining logs of equipment and physical plant maintenance. These documents can provide a chronological profile of the operating environment and reveal recent alterations to the process equipment that may have enough impact to disqualify the product from retrospective validation consideration. For this reason, it is always prudent to contemplate equipment status early in the information-gathering stage. The availability of such information should be ascertained for yet another reason: rarely is equipment dedicated to

one product. More often than not, each blender, comminutor, tablet press, and so forth is used for several operations. Information gathered initially can therefore be incorporated into subsequent studies.

Retrospective validation is directed primarily toward examining the records of past performance, but what if one of these documents is not a true reflection of the operation performed? Suppose that changes have crept into the processing operation over time and have gone unreported. This condition would result in the validation of a process that in reality does not exist. It is therefore essential to audit the existing operation against the written instructions. There is obvious advantage to undertaking this audit before commencing data acquisition. Ideally, the manufacture of more than one batch should be witnessed, especially where multiple-shift operations are involved. The same logic would apply to the testing performed in process and at the finished stage. If any deviation from the written directions is noted, an effort must be made to measure its impact. In this regard, the previously described validation organization is a logical forum for discussion and evaluation.

As a rule, batches that are rejected or reworked are not suitable for inclusion in a retrospective validation study [7]. Indeed, a processing failure that is not fully explainable should be cause to rethink the application of retrospective validation. Nonconformance to specification that is attributable to a unique event—operator error, for example, may be justifiably disregarded. In such cases, the batch is not considered when the historical data are assembled.

Raw materials, both actives and excipients, can be a source of product variability. To limit this risk, there should be meaningful acceptance specifications and periodic confirmation of test results reported on the supplier's certificate of analysis. Also, purchases must be limited to previously qualified suppliers. A determination that such controls are in place should be part of any retrospective validation effort.

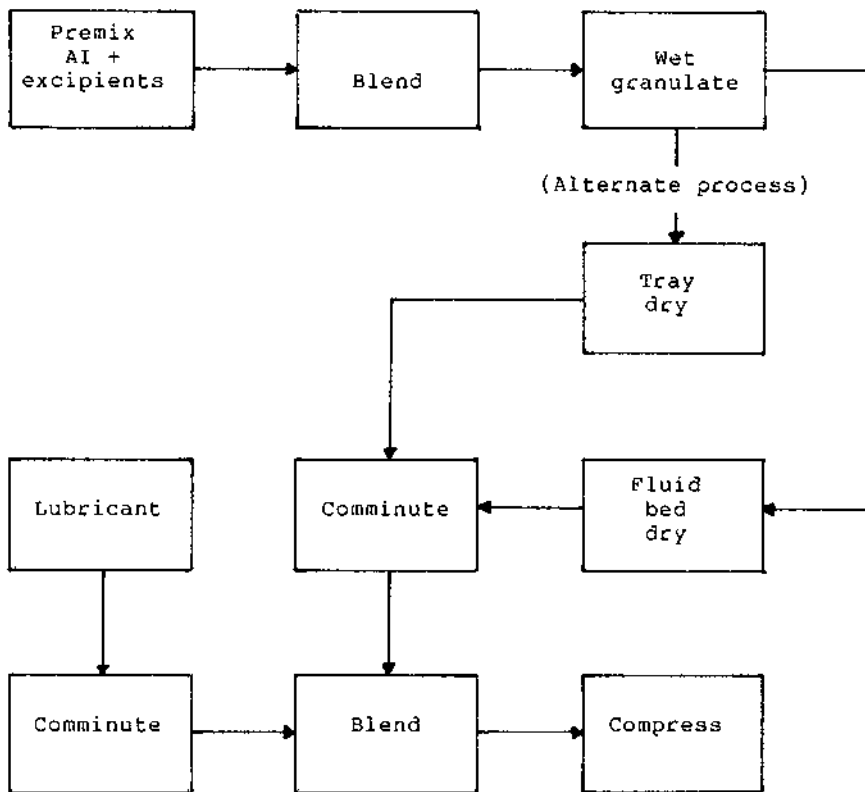
### **III. SELECTION AND EVALUATION OF PROCESSING DATA**

The following discussion will focus on how to apply the previously discussed concepts to the validation of marketed products. To provide a fuller understanding of this procedure, the manufacture of several dosage forms designed for different routes of administration will be examined. For each dosage form, critical process steps and quality control tests will be identified. Useful statistical techniques for examining the assembled data will be illustrated. It is also important to note that not all of the collected information for a product lends itself to this type of analysis. This will become more apparent as we proceed with the evaluation of the five drugs under consideration.

## A. Compressed Tablet (Drug A)

Drug A is a compressed tablet containing a single active ingredient. Inspection of the batch record reveals that the following operations are involved in the manufacture of the dosage unit. The active ingredient is combined with several excipients in a twin-shell blender. The premix just prepared is granulated using a purified water-binder solution. The resulting wet mix is milled using a specified screen and machine setting, then dried using either an oven tray dryer or a fluid bed dryer. When dry, the blend is oscillated, combined with previously sized lubricant, and blended. The granulation is then compressed. See Figure 2 for a flow diagram of the manufacturing process.

At the premix blending step, the batch record provides two pieces of infor-



**Figure 2** Drug A: flow diagram of manufacturing process.

mation: recommended blending time and blender load. The latter will be of little interest, as only one size batch is produced for this product. Blender speed is not specified in the batch record because it is fixed. Because mixing time has been recognized as influencing blend uniformity, this operation will become the first of the critical process steps for which we will want to collect historical information [8].

The second major step is granulation. The process is controlled by the operator, whose judgment is relied on for the appropriate end point. As no information useful for process validation is available, we will move on to the next step, comminution.

The batch record calls for passing the wet mix through a comminutor using a no. 5 or 7 drilled stainless steel screen. Knife position and rotational speed are two other factors that influence particle size; however, the step instruction is quite specific about machine setup. Therefore, only screen size is a source of variability for this step. We will want to know the frequency of use of each screen.

Next, the granulation is dried to a target moisture of 1%. Either a tray or fluid bed dryer may be used, at the discretion of area supervision. Regardless of the method, drying time will be of interest. In addition, the final moisture content should be ascertained for each batch. The dried granulation and lubricant are then oscillated using a no. 10 or 12 wire screen. This is the last sizing operation of the process; it will determine the particle size distribution of the final blend. Knowing the history of use of each screen size is thus important.

The lubricant and granulation are blended for several minutes. The elapsed mixing time is of interest because of its impact on drug distribution and the generally deleterious effect of the lubricant on dissolution.

Because excess moisture is thought to have a negative effect on the dosage form, loss on drying (LOD) is determined on the final blend.

Blending is followed by tableting. During compression, online measurements such as tablet weight, hardness, and disintegration are made by the process operator in order to ensure uniformity of the tablets. The weight of the tablets is not measured individually; rather, the average weight of 10 tablets is recorded. Although these data are good indicators of operation and machine performance, we would prefer to have the more precise picture provided by individual tablet weight.

Disintegration time and tablet hardness data could be collected from the manufacturing batch records; however, for ease of administration these figures will be obtained from the quality control test results, which also contain individual tablet weighings.

Disintegration time was selected as a critical variable because for a drug substance to be absorbed it must first disintegrate and then dissolve. The resistance of a tablet to breakage, chipping, and so forth depends on its hardness.

Disintegration, too, can be influenced by hardness of the tablet. For these reasons, hardness testing results also will be examined.

Specifications used by quality control to release drug A are found in a laboratory procedure. In addition to the previously discussed hardness and disintegration time requirements, the procedure calls for determining the average tablet weight by the United States Pharmacopeia (USP) procedure; that is, 20 individual tablets are weighed.

The control procedure also requires assay of individual tablets. Of all the information available, these data will be the most useful in reaching an opinion of the adequacy of the process to distribute the therapeutic agent uniformly.

In addition, the laboratory checks the moisture content of the bulk tablets. It will be interesting to compare these results to the LOD of the final blend to measure the contribution of material handling.

Critical manufacturing steps and quality control tests for drug A, identified as a result of the review, are summarized in Table 1.

## 1. Evaluation of Historical Data

Earlier in the discussion of process validation strategies, 20 production batches were suggested as a minimum number upon which to draw conclusions about the validity of the process. In this particular example, however, two distinct methods of drying are provided. In order to have sufficient history on each operation, the number of batches examined was increased to 30.

The batches were selected so that the same number was dried by each process. For the other critical manufacturing steps and release tests listed in Table 1, data were collected for all 30 batches.

The first manufacturing step, premix blending time, was consistently reported as 10 min, but with one exception. In this instance, the powders were tumbled for 20 min, which is still within the limits (10 to 20 min) prescribed by the batch record. It would be interesting to know if this source of variability

**Table 1** Drug A: Selected Critical Process Steps and Quality Control Tests

Process steps	Quality control tests
Premix blending time	Disintegration time
Comminutor screen size	Hardness
Drying time and method	Average tablet weight (ATW)
Loss on drying (LOD)—granulation	Assay
Oscillator screen size	Water content-bulk tablet
Final mix blending time	
LOD—final blend	



can materially affect attributes of the final product. Unfortunately, having only one batch produced by the 20-min process does not permit statistically valid comparisons. At best, test results for the single 20-min batch can be screened using summary data from the remainder of the study. Under different circumstances, batches would have been grouped by mixing time and compared by dosage form attributes. More than likely, subsequent manipulation of the blend would have negated any contribution, allowing us to conclude that a mixing time of 10 to 20 min is not unreasonable.

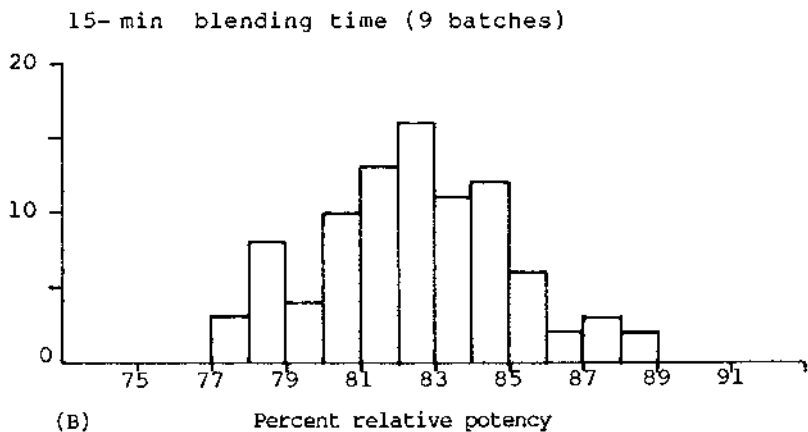
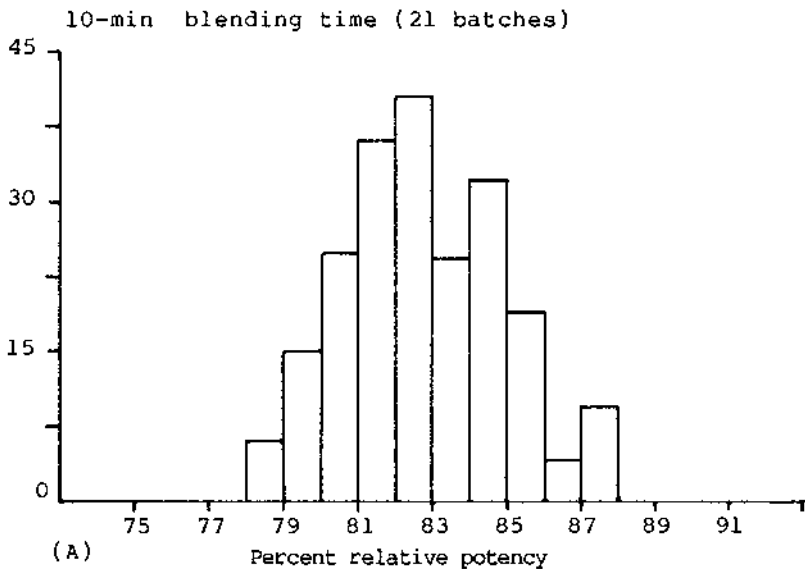
At the wet milling step we encounter a situation similar to preblending; that is, only two of the 30 study batches are prepared using the no. 5 drilled screen. The no. 7 is obviously the screen of choice. The purpose of this step is to produce particles of reasonably uniform size, which in turn will improve drying. From the records, we also know that the no. 5 screen was used only with batches that were tray dried. Elapsed drying time and residual moisture were compared for the two batches from the no. 5 screen process and the other 13 batches that were tray dried. No important differences were detected. Still, in light of the limited use of the no. 5 screen, it would not be inappropriate to recommend this option be eliminated from the processing instructions.

Mean drying time for the oven tray process is 19.2 hr. All 15 batches were dried within the specified time of 16 to 20 hr. No seasonal influence was apparent. The average moisture content of these batches is 1.2%; the standard deviation is 0.3%. The 15 batches dried using the fluid bed dryer had a residual moisture of 0.8% (SD = 0.1%). Drying time is mechanically controlled and not recorded. The statistics favor the fluid bed process; it is more efficient and uniform. There is nothing in these data to disqualify the oven tray dryer from further use, however.

Oscillation of the dried granulation and lubricant was accomplished in every instance using a no. 10 wire screen. Reference to the no. 12 screen, the alternative method for pulverizing the batch, must be deleted from the manufacturing instructions for the process to be validated retrospectively.

The final mix blending time was reported as either 10 or 15 min. Twenty-one of the 30 batches were tumbled for 10 min and the remainder were mixed for 15 min. The mixing time is not mechanically controlled or automatically recorded; it is left to the operator to interpret elapsed time. Because of the importance of the step to distribution of the therapeutic agent, a comparison was made between the distribution of the percentage of relative tablet potency [(tablet assay/tablet weight)  $\times$  100] for the two mixing times. The frequency distributions of the two populations are shown in [Figure 3](#).

The two histograms are visually different, with the 15-min process exhibiting more dispersion. Despite this difference both populations are tightly grouped, which is a reflection of the uniformity of the blend.



**Figure 3** Histogram of drug A granulation uniformity resulting from different blending times. Percentage of relative potency = (tablet assay/tablet weight)  $\times$  100.

The processes may be studied quantitatively by comparing the means and standard deviations of the two populations. The effect of final blend time on lubricant distribution was examined by comparing disintegration time statistics for the grouped data. None was noted.

The moisture content of the 15 tray-dried batches following final mix remained essentially unchanged from the drying step. The batches from the fluid bed process gained moisture. This is probably attributable to handling very dry material in a relatively humid environment. Both groups are still below the target for this step of 1.5 %, however.

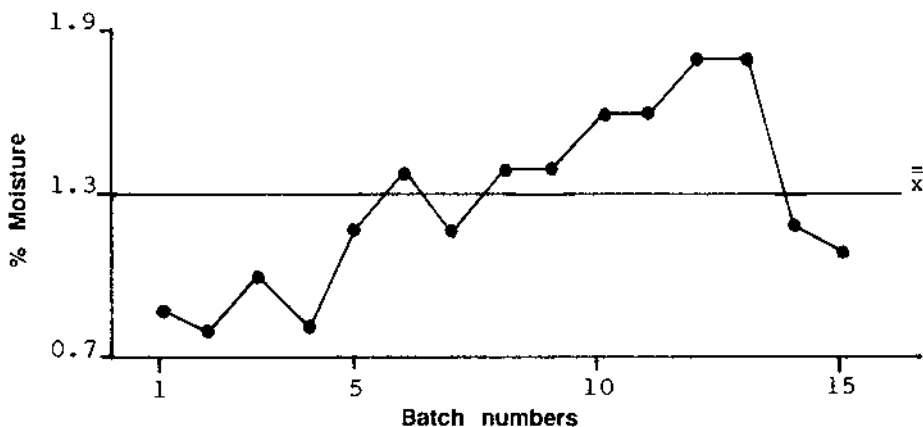
Table 2 gives a comparison of the moisture contents following the drying and tumbling steps. The sizable increase in mean moisture content of the fluid bed-dried batches deserves further study. To determine whether or not all batches were uniformly affected, the mean moisture content was plotted in the order in which the batches were produced. Whereas the plot for the tray-dried batches is unremarkable, the fluid bed process chart (Fig. 4) depicts an unnatural pattern. Further investigation discloses that heating, ventilation, and air condition (HVAC) problems were experienced by the area in which a number of these batches were blended.

During compression, 1000 tablets were randomly selected for use by quality control. Inspection of the batch records revealed that all 30 batches were compressed on the same model press operating at approximately the same speed. All presses were fed by overhead delivery systems of the same design, thus tableting equipment will not be a source of variability from batch to batch.

The test for disintegration is performed as described in the USP, and the results are rounded to the nearest half-min. Disintegration time varied over a narrow range for all batches studied. The 15-batch average for the tray dryer process (2.7 min) is well below the specification (10 min) for this test. Hardness of tablets from the tray dryer process averaged 15 Strong–Cobb units (SCU). All batches exceeded the minimum specification (9 SCU); there is no upper

**Table 2** Drug A: Comparison of Oven Tray Dryer and Fluid Bed Dryer Processes

Test	Oven tray process ( $\bar{x}$ )	Fluid bed process ( $\bar{x}$ )
Moisture dried granulation (%)	1.20	0.80
Moisture final mix (%)	1.10	1.30
Moisture bulk tablet (%)	1.26	1.50
Hardness, Strong–Cobb units (SCU)	15.00	16.70
Disintegration (min)	2.70	3.00

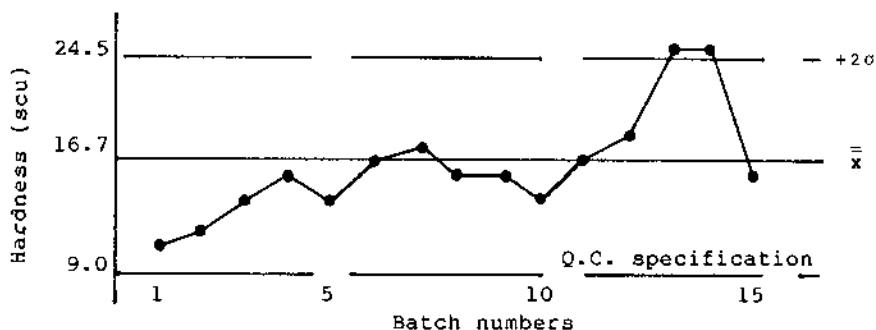


**Figure 4**  $\bar{x}$ -control chart for drug A percentage moisture at final blend step (fluid bed process).

limit. Hardness and disintegration time are not well correlated, probably due to rounding of test results and the need to compare averages.

On average, tablets from the fluid bed process were slightly harder. Also, the individual batches had a greater range of hardness than batches from the alternative drying process. Disintegration time for the fluid bed process averaged 3.0 min. Individual batches ranged from 2.0 to 4.5 min. As with the tray process, no correlation was found between hardness and disintegration time. In summary, tablets from the fluid bed dryer process were somewhat harder and took slightly longer to disintegrate. (See Table 2.) These differences are considered insignificant, however. If any recommendations were made, it would be to lower the disintegration time specification or establish an internal action limit closer to the historical upper range of the process.

Control charts were plotted for hardness and average tablet weight (ATW) to evaluate process performance over time. Separate charts were prepared for the tray dryer and fluid bed processes. Hardness values are an average of 10 individual measurements. The ATW subgroups are the result of weighing 20 tablets individually. The control charts were inspected for trends and evidence of instability using well-established methods [9]. Only the control chart for hardness of tablets from the fluid bed process responded to one of the tests for pattern instability (Fig. 5); that is, two of three consecutive points exceeded the 2-sigma limit. From the chart it is obvious the general trend toward greater tablet hardness (from 11 to 25 SCU) is the underlying cause of the instability. The trend to greater hardness was subsequently arrested and may have to do



**Figure 5**  $\bar{x}$ -control chart for drug A tablet hardness (fluid bed process).

with attempts to regulate another tablet variable—thickness, for example—although the records are vague in this regard.

Water content of the bulk tablets irrespective of the drying process was higher than at the final mix stage (Table 2). This is probably due to the compression room environment and the low initial moisture of the powder. Still, the specification limit of 2% is easily met.

The FDA has recently issued draft guidelines that recommend blend uniformity analysis for all products for which USP requires content uniformity analysis [10]. The USP requires this test when the product contains less than 50 mg of the active ingredient per dosage form or when the active ingredient is less than 50% of the dosage form by weight. The concern FDA has is that if blend uniformity is not achieved with mixing of the final granulation, then some dosage units are likely not to be uniform [11]. Blend uniformity is not routinely determined for drug A, nor is there a requirement because the dosage form is over 50% active ingredient. In the absence of historical information about uniformity of the blend, the relationship between tablet weight and potency should be carefully examined.

Tablet weight should bear a direct relationship to milligrams of active ingredient available where the final blend is homogeneous. This conclusion assumes that demixing does not occur as the compound is transferred to intermediate storage containers or to a tablet press hopper [12]. To measure the likelihood that controlling tablet weight assures dosage uniformity, 50 tablet assays selected at random (from 300 tablet assays) were compared to tablet weight using regression analysis. Because the same model tablet press and blender were employed for every batch, assay results from all 30 batches were pooled. The mean purity of the 25 receipts of active ingredients used to manufacture the 30 batches in the validation study was 99.7%, or 0.3% below target. Individual lots ranged

from 98.8–102%. Because of these lot-to-lot differences, active ingredient raw material potency was also included in the regression analysis.

The general model from the regression analysis is [13]

$$y = b_0 + b_1X_1 + b_2Y_2$$

where

$y$  = tablet potency

$b_0$  = constant

$X_1$  = raw material purity

$X_2$  = tablet weight

Tablet potency was found to be related to raw material purity and tablet weight as follows:

$$y = -414.6 + 6.6050X_1 + 0.4303X_2$$

We would expect the regression plane to have a significant positive slope; that is, as purity of the active ingredient and tablet weight increase, so will tablet potency, and this was found to be the case. Both slopes are statistically significantly different from 0 at  $\alpha = 0.025$ . When the above equation is used to predict tablet potency given the ideal tablet weight (600 mg) for the product and mean raw material purity of 99.7%, the resulting value is only 2.1 mg different from the theoretical value of 500 mg.

In conclusion, drug A production was shown to be within established specifications, and there is no reason to believe this will not be the case for future production as long as all practices are continued in their present form. Furthermore, there is no significant difference between batches produced by the tray dryer process and the fluid bed process. A validation report should memorialize these findings. The report should also recommend eliminating the option to use a no. 5 screen for the wet milling step and a no. 12 screen to pulverize the dried granulation. There is no experience or only limited experience with this equipment that supports its continued availability. In the same vein, the final blend time should be standardized at 10 min and automatically controlled by means of a timer.

## **B. Coated Tablet (Drug B)**

Let's now turn our attention to a different dosage form, applying some of the strategies developed during the examination of drug A. Again we want to identify the process steps that are responsible for distributing the active ingredient as well as the tests that measure the effectiveness of those actions. Drug B is a sugar-coated tablet prepared in the traditional manner; that is, layers are slowly built up around a core by applying a coat of shellac and then subcoating, gross-

ing, and smoothing coats until specifications are met at each stage. In the case of drug B, the core contains two active ingredients. The coating, on the other hand, has no medicinal value and is intended solely to enhance the aesthetic appearance of the product. The manufacturing process is shown in [Figure 6](#).

[Table 3](#) summarizes the selected critical steps for the manufacture of the core tablet of drug B. The core is prepared by dry-blending the first active ingredient (i.e., B1) with several excipients. Blend time is of interest for its impact on the distribution of the therapeutic agent. The premix just prepared is granulated using an alcohol-binder solution. The process directions allow the operator some latitude in using additional alcohol to ensure that the batch is uniformly wet. It will be necessary to know whether or not additional alcohol is routinely required, and if so, how much is used. Besides measuring operator technique, the wetting step affects particle size distribution. The oven tray dryer is identified for drying the wet mix. Granulation drying time is of interest, because loss on drying is not measured. Once dry, the granulation is milled using a specified screen size and machine setting. Alternate equipment is not provided for in the aforementioned steps.

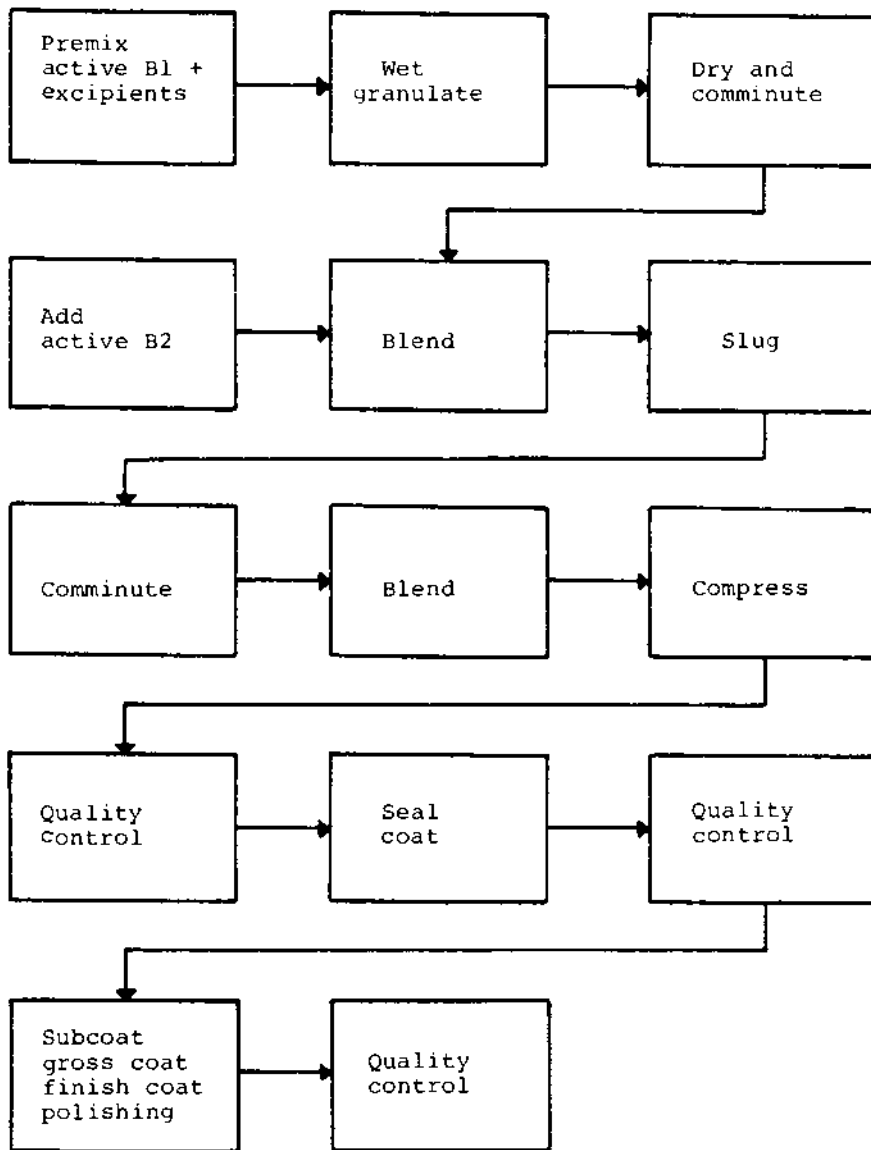
The powder produced in the prior operation is combined with the second active ingredient (B2), as well as several other excipients in a twin-shell blender and mixed for several min. For reasons previously discussed, mix time is of interest, and thus it is listed as a critical process step.

The blend of the two active ingredients (B1 and B2) is slugged and then the slugs are oscillated. Slugger model and tooling are listed in the batch instructions. The thickness of the slug is specified, but no information is recorded on the slugging operation, as control of this procedure is left to the experience of the press operator. The batch record permits the use of only one screen size. Since all of the batches have been made in the same manner, this important process step will not be included as one to be studied.

Next, lubricant and oscillated granulation are blended for several min. The elapsed mixing time is of interest because of its impact on drug distribution and the effect of the lubricant on dissolution. During compression, 1000 randomly selected cores are accumulated for use by quality control.

The ATW, hardness, and disintegration time are determined by the press operator during compression. As in the case of drug A, we will not rely on these results for our study, but rather on the test data from quality control.

Following approval of the bulk cores by quality control, they are shellac-coated. According to the manufacturing directions, one or two coats may be applied based on the process operator's judgment. A third coat is permissible but only in response to directions from the supervisor. In any event, the actual number of coats applied is recorded in the batch record. Because of its potential impact on drug availability, this information is listed as a critical parameter in [Table 3](#).



**Figure 6** Drug B: flow diagram of manufacturing process.



**Table 3** Drug B: Selected Critical Process Steps and Quality Control Tests

Process steps	Quality control tests
Premix blending time	Average tablet weight (core and coated tablet)
Quality of additional alcohol used	Hardness
Granulation drying time	Disintegration time (core, shellacked core, and coated tablet)
Blending time to combine active ingredients B1 and B2	Assay for active ingredients B1 and B2
Final blending time	
Number of shellac coats	
Number of build up coats	
Coating pan temperature	

Once the shellacking stage has been completed, the cores are built up through a series of coating operations. The number of applications of coating solution, the volume of coating solution applied, and the coating environment can influence product performance and therefore need to be studied.

The quality control tests selected after review of in-process and finished-product specifications are listed in Table 3. The rationale for selection has been addressed in general terms during the review for drug A. These quality control tests, while informative, provide no insight into how the shellac coating will behave a number of years from now. For some perspective, we can examine the stability profile of commercial batches placed into the stability program. Of course, the batches considered would have been made by the same process as the one being validated. Particular attention should be paid to disintegration and dissolution results.

### 1. Evaluation of Historical Data

Only 19 batches of drug B are available for examination, one shy of the minimum number previously suggested. The obvious course of action is to delay the study until additional batches are produced. For reasons that will become apparent later, the data analysis will be started with the batches immediately available.

Inspection of assembled data for the 19 batches of drug B confirmed that premix blending was consistently performed for 15 min as specified in the manufacturing directions.

On average, 11.5 kg of additional alcohol was needed to wet the premix adequately. The actual quantity used ranged from 6 to 16 kg, and in no instance was a batch produced without the use of extra alcohol. These data support an increase in the minimum quantity of alcohol that is specified in the manufacturing directions.

Granulation drying time was unremarkable. All 19 batches were dried within the specified time of 12 to 16 hr; the mean time was 13.4 hr, and no trends, seasonal or otherwise, were detected.

The operator is instructed to combine the premix containing active ingredient B1 with active ingredient B2 and blend for 30 min. All 19 batches were handled as directed in the batch record. Oscillation of the slugs back to powder was accomplished in every case using the screen listed in the batch record. For final granulation, we found that each batch was blended for 30 min, as directed. There is no blend uniformity testing.

Once the cores are compressed, one to three sealing coats may be applied by the process operator. The third coat was never required, however. All 19 batches were completed with two coats of shellac. The volume of shellac applied was always 350 mL for both steps, as required by the batch record, and the record further indicates that the temperature of the air directed into the coating pan was always set at 40°C. There is no record of the temperature being monitored, however. The shellacked cores were dried overnight at 35°C. The dryer temperature was tracked and automatically recorded; no variability was encountered when the temperature chart was reviewed.

The marketable dosage unit is arrived at by the slow buildup of layers on the shellacked core through the hand application of coating solution. This finishing step is intended solely to enhance appearance by concealing surface irregularities and should have no effect on drug delivery. The three coating solutions are compounded as part of the batch process and immediately prior to being needed. The directions call for the subcoating solution to be held at  $65^{\circ}\text{C} \pm 2^{\circ}$  following compounding and applied at this temperature. Up to five applications are permissible to achieve the tablet target weight of 380 mg; however, for the 19 batches in this study either three or four coats were applied. The impact of varying the number of solution applications was studied by forming the batches into two populations. Mean tablet weight, total volume of solution applied, and mean disintegration time were compared. Unfortunately, the only available disintegration measurement was from a test run on the fully built-up tablet (Table 4). The tablets from batches with three applications of subcoat solution had slightly lower weights on average (6 mg), relative to the other group. The volume of coating solution varied considerably by application (475 to 700 mL), and the total volume was slightly lower when there were only three applications. Mean disintegration time of the groups differed by less than 30 sec, which is insignificant, given the test methodology.

Additional layers are added to the tablet using a grossing solution that is similar to the subcoating formula and contains a colorant. As many as 15 applications may be needed to achieve the target weight of 450 to 490 mg. Warm air (32–38°C) is applied between coats to achieve drying. A dial thermometer is visible to the operator, but there is no requirement to log the actual tempera-

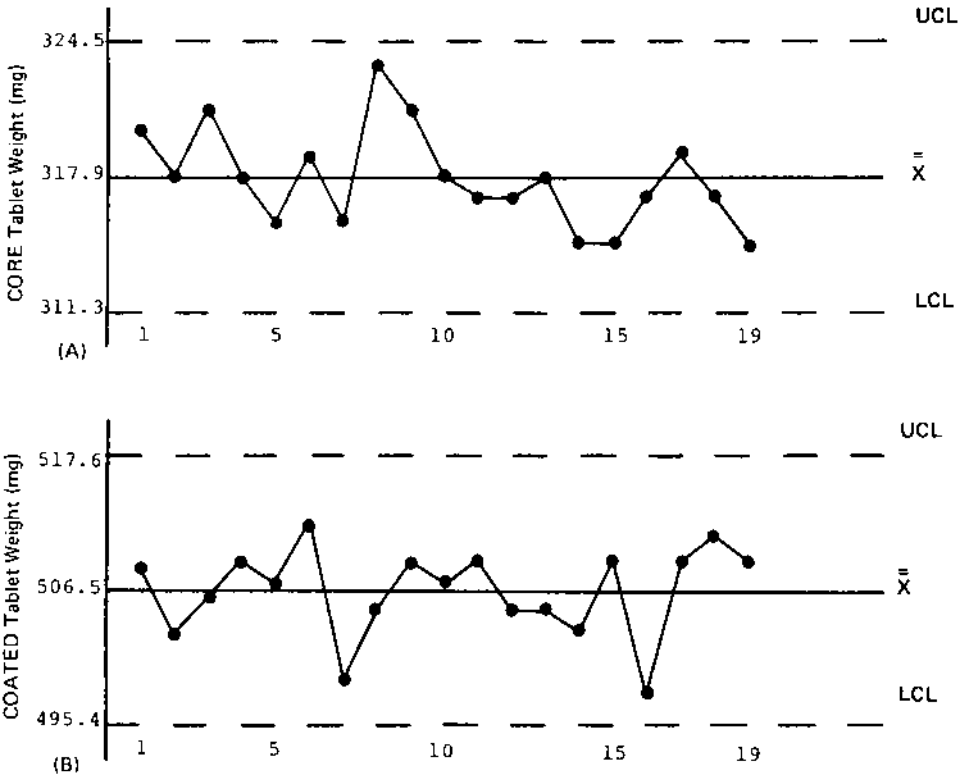
**Table 4** Drug B: Comparison of Mean Hardness and Disintegration Times

Batch number	Hardness (SC units)	Disintegration time (min)		
		Core tablets	Shellacked cores	Coated tablets
01	11	8	15	22
02	10	9	20	25
03	10	8	19	21
04	11	9	16	22
05	8	8	13	17
06	8	8	14	18
07	8	7	14	21
08	9	8	14	20
09	8	8	15	20
10	10	8	17	19
11	12	9	13	20
12	12	8	13	20
13	8	7	14	17
14	8	7	13	18
15	12	8	13	18
16	10	11	17	23
17	11	9	20	26
18	10	8	18	20
19	9	7	14	19
$\bar{x}$	9.74	8.16	15.37	20.32
RSD	15.30	11.76	15.81	12.15

ture. In the manner previously discussed, the total number of applications, volume of solution consumed, and tablet weight achieved were analyzed. Variability was present between batches, but populations that received different treatment were quite similar with respect to tablet weight and disintegration time (as measured at the finished tablet stage).

A finishing solution is used to bring the tablet to its final weight. The operation is very much as previously described except that fewer coats are applied and therefore less weight is added. An analysis of the data would follow the strategy just discussed.

Let's next direct our attention to the testing done by quality control. The ATW at the core stage is based on the results from weighing 20 randomly selected tablets. The control chart in [Figure 7](#) depicts a process with no single



**Figure 7** (A)  $\bar{x}$ -control chart of drug B average tablet weight (core stage). (B)  $\bar{x}$ -control chart of average coated tablet weight for drug B.

value outside the upper control limit (UCL) or the lower control limit (LCL). Other tests for instability show the process to be operating normally. All 19 batches were compressed on the same model press, according to the batch record. The ATW for the coated tablet is shown for comparison. Correlation between core weight and finished tablet weight is poor. Such fluctuations would be expected of a manual coating operation intended solely to enhance pharmaceutical elegance, nevertheless the control chart did not respond to our tests for patterns of instability (Fig. 7).

Disintegration time is measured at three steps in the process: at compression, after application of the second shellac coat, and at finished product release. Table 4 compares the values of mean hardness obtained for 10 individual cores to the disintegration times for the core, shellacked core, and coated tablets. No

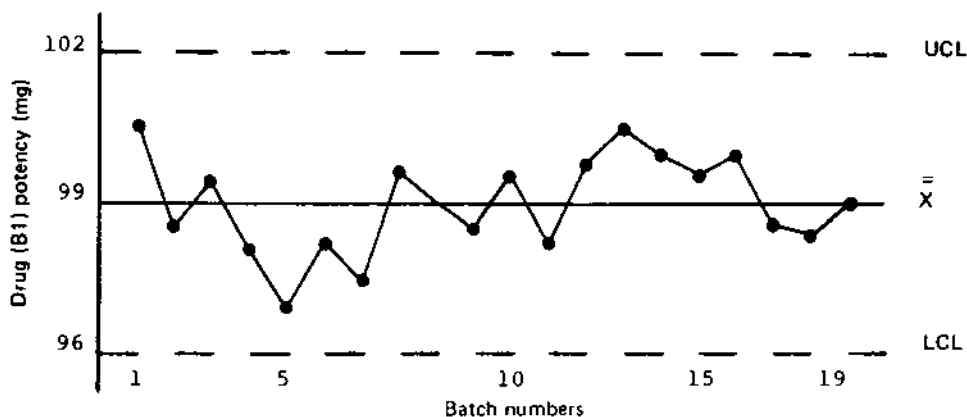
relationship was found between core hardness and uncoated core disintegration time. The 5-min increase in mean disintegration time from shellac coated core to finished tablet is a measure of the contribution made by the finishing steps.

Receipts of active ingredient raw materials B1 and B2 are accepted by quality control based on standard tests for potency, chemical attributes, and particle size. Particle size is determined by sieve analysis. Unfortunately, this is a limit test in which 99% of the sample must pass through a certain mesh screen, therefore any influence particle size distribution might have on dosage form potency cannot be examined.

Figure 8 is a plot of mean assay results for active ingredient B1. Drug potency (200 mg per tablet) is measured in duplicate from samples obtained by grinding a composite of 20 randomly selected tablets. Figure 8 is also influenced by the variability of the purity of the raw material, which ranged from 97.6–99.5%.

Nevertheless, the pattern was unresponsive to our standard tests for process instability, and individual batch results were well within established control limits for this product (180 to 220 mg). The grand mean of 99.0% is 2.0 mg below the theoretical tablet potency, probably because of below-target purity of the active ingredient raw material.

Content uniformity testing is not a requirement for drug substance B1, hence no information is available about the weight of the active ingredient in individual dosage units. With so much emphasis today on demonstrating adequate control over this variable, a one-time study run concurrently with the next production should be considered. Kieffer and Torbeck suggest two statistical



**Figure 8**  $\bar{x}$ -control chart for drug B tablet assay (ingredient B1).

techniques—the tolerance interval and capability index (Cpk)—may be used to demonstrate uniformity of the drug substance in the dosage form [14]. The starting point is to assay individually a representative sample of tablets (e.g., 30) from a series of batches. Regression analysis also can be performed to assess the influence of tablet weight and raw material purity on potency with the availability of data for individual tablets.

Active ingredient B2 (25 mg per tablet) is measured on 10 individual tablets per batch. We randomly selected 50 tablets from the 19 batches for use in regression analysis. Because purity of the raw material varied from 98.4–99.7%, it was included as the second variable. Our predictor equation for tablet potency ( $y$ ) is

$$y = -51.10 + 0.5342X_1 + 0.0752X_2$$

where

$X_1$  = raw material

$X_2$  = tablet weight

The slope of the regression plane was found to be positive for both tablet weight and raw material purity, as we would expect. The slope for tablet weight was statistically significantly different from 0 at  $\alpha = 0.01$ , while the slope for purity was significant at  $\alpha = 0.05$ .

Substituting the ideal tablet weight (at the core stage) of 320 mg and mean raw material purity of 99% in the above equation yielded a tablet potency of 25.85 mg, or 0.85 mg greater than theoretical. The predicted tablet potency is close to the ideal and well within specification limits (22.5 to 27.5 mg). It is possible this outcome was influenced by differences arising from the method of determining the purity of the raw material and the potency of the dosage form. The former is a wet chemistry analysis, whereas the potency of the drug in the finished tablet is determined by use of an automated procedure. Unfortunately, we were unable to quantify this difference.

The process for drug B has been shown to operate within narrow limits and yield finished dosage forms that are therapeutically equivalent, as measured by standard product release criteria. There is no reason to believe subsequent batches will perform differently as long as all conditions remain static. Despite this generally favorable prognosis, additional work is necessary to provide the assurance of process reliability expected today.

1. There remains the unanswered requirement to demonstrate blend uniformity of active ingredients B2. This issue might be addressed by testing the blends of a series of batches until sufficient data are accumulated to consider the process reliable. Hwang et al. have provided some insight into establishing an in-process blend test [15]. The vali-

dation committee might also suggest that an individual tablet assay be performed for active ingredient B1 during this period. The aforementioned statistical treatments would then be employed to demonstrate that tablet potency is well controlled.

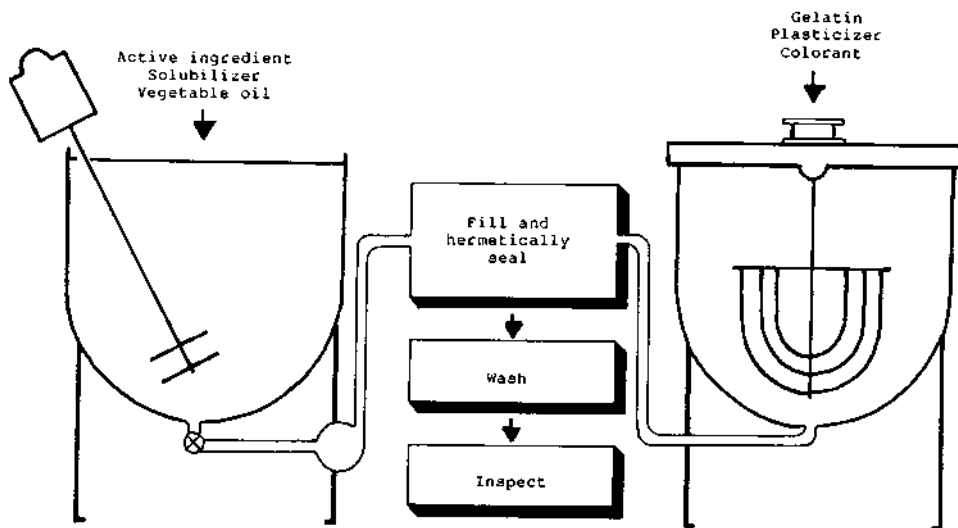
2. Only 19 batches of drug B were considered suitable for the validation study. This number is shy of our stated goal of a minimum of 20 batches. We therefore will want to supplement the data from the original 19 batches. This effort should be coordinated with the blend uniformity testing.
3. Details of the slugging step need to be improved, both to assure consistency and to facilitate third party monitoring. All of these recommendations should be memorialized in the validation report.

### **C. Softgels (Soft Gelatin Capsules; Drug C)**

This dosage form consists of a solution of active ingredient encased within a spherical, plasticized gelatin shell. Unlike hard gelatin capsules, for which several discrete operations are required to produce the final product, the softgel is formed, filled, and hermetically sealed in one continuous operation [16]. Molten gelatin mass is formed into two sheets or ribbons, each of which passes over a die of the desired size and shape. At the point at which the two rotating dies meet, the hemispheres are sealed and simultaneously filled with the solution of active ingredient. Next the capsules are cleaned by immersion in an organic solvent, dried, and inspected. (See Fig. 9.)

According to the process instructions, the active ingredient powder is dissolved in vegetable oil with the aid of a solubilizer. Blend time is stated as 25 to 30 min. This is an elapsed time. Because a range of time is permitted, this step is one for which historical data will be sought (Table 5). The bulk solution is assayed to confirm that the prescribed weight of drug C was charged and dissolution is complete before capsule filling may proceed. Concentration of the active ingredient should vary very little from one batch to another with such a straightforward process. We will want to confirm that this is the case. The purity of each active ingredient raw material receipt is also of interest for reasons previously stated.

The instructions for gelatin mass preparation direct that gelatin powder be blended with water, a plasticizer, and colorant until a uniform consistency is achieved, then heated until molten. The recommended blend time is 20 min at a temperature of  $60^{\circ}\text{C} \pm 5^{\circ}$ . The temperature of the molten gelatin just prior to formation into a ribbon is critical; too high a temperature causes the gelatin to deteriorate, and a low temperature affects flow rate. Both conditions are to be avoided for their deleterious effect on capsule formation. For these reasons,



**Figure 9** Drug C: flow diagram of manufacturing process.

gelatin mass temperature is listed in Table 5. Blend time is of interest, too, as a measure of process and raw material performance.

An important specification for gelatin is bloom strength, a quality of the raw material that determines whether or not a capsule can be formed and sealed. As with active ingredient purity, we will want to know this value for each lot of gelatin used in the validation study.

Speed of die rotation and gelatin ribbon thickness are two important machine conditions that are included in Table 5. The rationale of their selection is

**Table 5** Drug C: Selected Critical Process Conditions and Quality Control Tests

Critical process conditions	Quality control tests
Blend time to solubilize active ingredients	Bulk assay
Gelatin mass mix time and temperature	Dissolution
Die rotation speed	Average fill weight
Gelatin ribbon thickness	Dosage form assay
Relative humidity of encapsulation room	Microbial content



as follows: die rotation speed controls dwell time. If there is insufficient contact time, the capsule halves will not properly seal. Subpotent softgels may result from loss of liquid fill through a poorly developed seam. Gelatin ribbon thickness determines capsule wall and seam thickness. Insufficient thickness will contribute to poorly formed capsules and leakers. An overly thick ribbon results in shell sealing problems. Ribbon condition is influenced by the temperature of the gelatin mass, as previously noted. Relative humidity in the encapsulation room is important to efficient drying. Minimally, we will want to know the room condition during the time in which the 20 batches in this study were manufactured. It would be best to examine environmental conditions over a longer time period, say 1 year, to capture seasonal trends should they exist.

The batch record instructs the encapsulation machine operator to measure and record seam and wall thickness every 45 min. Softgel weight is also checked periodically by this operator. This information could be useful in demonstrating process control but to a large extent seam and wall thickness are controlled by manufacturing conditions for which historical data are already being sought. For this reason, the results of these in-process monitors need not be pursued initially. Consistent with the approach taken for other dosage forms previously discussed, finished softgel weight data can be obtained from quality control reports when dissolution and assay results are collected.

## 1. Evaluation of Historical Data

The first step in the production sequence is solubilizing the active ingredient in an appropriate volume of vehicle. For drug C, this blend is a solution, and the activity was routinely accomplished in the prescribed time (25 to 30 min). The analytical test results of each bulk batch confirmed that small differences in mix time had no impact. The nine receipts of active ingredient raw material used to prepare the 20 batches under review had a mean potency of 99.5%. Individual receipts ranged from 98.7–102%. No trends were noted when these receipts were examined graphically.

Gelatin mass preparation time was recorded as being between 17 and 23 min. Such small differences were not thought to be worthy of further consideration. Gelatin mass temperature is critical for reasons previously noted. The temperature range achieved during compounding was examined by means of the recorder charts for evidence of equipment problems and lack of operator attention. The degree of variability within a batch and from batch to batch was considered reasonable for an operator-controlled process of this type. Mass temperature at the end of compounding, just before the start of encapsulation, averaged 60.5°C. Individually, all batches met the specifications of 60°C ± 5°. Control over gelatin mass temperature for the duration of the filling operation was generally unremarkable, although larger fluctuations were present for four of

the 20 batches in the latter stages of filling. The cause of these fluctuations was not apparent, however.

A bloom strength determination is part of the acceptance criteria for each receipt of gelatin raw material. The bloom gelometer numbers range from 125 to 195 for the 12 lots, with a mean of 147. This number was compared to gelatin ribbon thickness and die rotation speed during encapsulation to ascertain whether lot-to-lot differences had to be compensated for. No relationship was found.

Encapsulation machine setup specifications were considered for their impact on softgel seam and wall formation. Die speed is given as 4.0 rpm  $\pm$  0.2. Gelatin ribbon thickness is to be controlled at 0.032 in.  $\pm$  0.003. More than one machine was used to produce the 20 batches; however, they were all the same make and model. Machine settings during encapsulation are summarized in Table 6. Slight machine-to-machine differences are present, but all three operations are easily within suggested settings for this product. On average, gelatin mass temperature was the same for each encapsulation machine.

The influence of gelatin mass temperature, gelatin ribbon thickness, and die speed on softgel formation and the interactions of these variables were explored by regression analysis as follows:

$$\begin{aligned} \text{Finished softgel weight} = & \text{gelatin mass temperature} + \text{die speed} \\ & + \text{gelatin ribbon thickness} \end{aligned}$$

The outcome was inconclusive, probably due in part to use of data that did not take into consideration the variability in fill volume.

Quality control release testing was performed on a sample taken from 1000 softgels randomly selected at the conclusion of processing. The outcome of dissolution, assay, and average fill weight tests is reported in Table 7, along with the corresponding specification. These data were analyzed using methods previously illustrated. In addition, all batches passed the microbial limits test.

**Table 6** Drug C: Encapsulation Machine Settings (Die Speed and Ribbon Thickness)

Machine number/batches	Die speed ( $\bar{x}$ ; rpm)	Ribbon thickness ( $\bar{x}$ ; in.)
All machines ( $N = 20$ )	4.01	0.032
Machine 1 ( $N = 7$ )	3.93	0.032
Machine 2 ( $N = 7$ )	4.07	0.031
Machine 3 ( $N = 6$ )	4.02	0.033

**Table 7** Drug C: Quality Control Release Specifications and Results

Test	Specification	Result ( $\bar{x}$ )
Dissolution (%)	NLT 75%	89.1
Average fill weight (mg)	855–945	901.7
Assay (mg)	475–525	516.2

Dissolution and average fill weight results are not remarkable. Active ingredient assays averaged 16 mg above midpoint of the specification, which is not assignable to raw material purity which averaged 99.5%. Examination of in-process checks of wall thickness showed this parameter to be under control at all times, effectively ruling out fill volume as a factor. One explanation could be the manner in which the active ingredient solution is prepared. It is noteworthy that all 20 batches exceed the midpoint of the bulk solution specification. Individual batches range from 509 to 523 mg when expressed in terms of target fill weight (900 mg). This distribution suggests that a condition common to all the batches is part of the explanation. The analytical methodology used to release the bulk and finished dosage form would be a good place to start such an investigation.

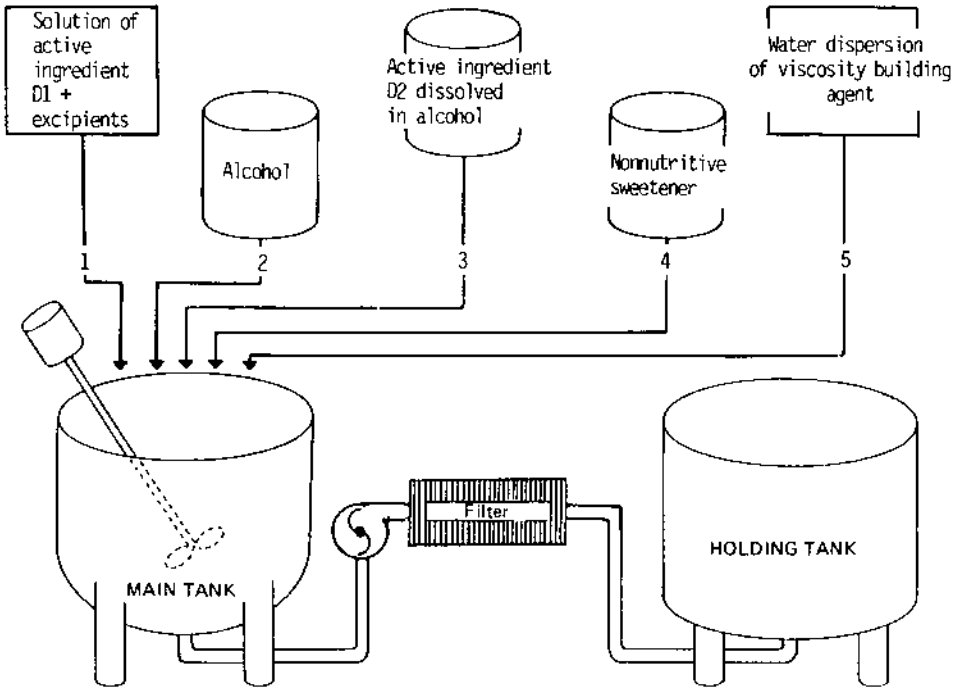
Available information reveals a process that is consistently reproducible and can be considered validated on that basis. Before doing so, however, the assay results should be justified and the outcome of this investigation included in the validation report.

#### **D. Solution Dosage Form (Drug D)**

The solution dosage form to be discussed is an elixir. A review of the batch record shows that it contains two active ingredients (D1 and D2). The different steps in preparing the dosage form are outlined in [Figure 10](#).

Drug D may be produced in both 1000- and 2000-gal batches to meet inventory requirements. Major equipment and operator instructions are the same regardless of batch size. The only difference is the amount of each ingredient charged to the make tank. With a formulation such as this, there is little likelihood that batch size is an important process variable. Nevertheless, we will be conservative and treat each size batch as a unique process. An alternative strategy would be to validate the 2000-gal process and demonstrate for the 1000-gal batch the adequacy of mixing, using, for instance, assay data.

The batch is prepared using a single tank. Large-volume liquid excipients and deionized water are metered into the main tank. The other materials are



**Figure 10** Drug D manufacture: flow diagram showing major sequences of steps as described in Manufacturing Batch Record. The numbers indicate the order in which the process is carried out.

preweighed. Final yield is calculated from a freeboard measure of the bulk liquid in the holding tank. Variable-speed agitation is available; however, the batch instructions do not require the rate of mixing to be adjusted from step to step, nor are temperature adjustments needed to get the solid raw materials into solution. A standard filter press is employed to clarify the batch just prior to transfer to the holding tank, thus the only variable information available from the batch record is the time required to accomplish such steps as addition, mixing, and dissolution of raw material active ingredients in vehicles. Although the elapsed time to perform these steps is identified in Table 8 as a process variable to be considered, this information is useful only as a crude measure of operator performance.

Yield at the conclusion of processing is available from the batch record and is identified in Table 8 as an important step. Yield data are potentially

**Table 8** Drug D: Selected Critical Process Steps and Quality Control Tests

Process steps	Quality control tests
Elapsed time to complete steps A, B, and C	Appearance
Batch yield	pH
	Specific gravity
	Viscosity
	Alcohol (% v/v)
	Assay of active ingredients D1 and D2

useful in explaining atypical quality control test results; they also provide a rough measure of equipment condition and operator technique.

The quality control test results for each batch are relied on almost exclusively for the critical information used in this study. The rationale for selecting the finished dosage form parameters listed in Table 8 is as follows.

The physical appearance of the finished product is a good indicator of the adequacy of the filtration step. Although it is only a subjective test, it does provide information on equipment performance. The pH of the finished dosage form is critical for the stability of active ingredient D1, hence its measurement is warranted. Specific gravity reflects the quantities of ingredients charged, as well as adequacy of the mixer to distribute them uniformly. A viscosity check is performed to ensure that no untoward viscosity buildup has occurred that could affect pourability. Viscosity of the end product can also indirectly indicate the quality of the dispersion of the viscosity-building agent. Determination of the quantity of alcohol in the end product is critical as well, because the solubility of one of the active ingredients, D2, depends on the concentration of alcohol. Also, because alcohol can easily be lost during processing, any values below the established limit would be evidence of a problem associated with the process. Finally, concentration of the active ingredients is measured. These data attest to the adequacy of both the dissolution of each ingredient and the subsequent mixing during phase combination. Any major deviation from established limits would indicate problems in manufacturing. Because raw material active ingredient purity is known to vary from one receipt to the next, it too should be included in any review of dosage form potency.

## 1. Evaluation of Historical Data

The time required to accomplish mixing and addition steps is summarized in Table 9. The differences in elapsed time were thought to reflect those typically encountered in manual operations. Batch yield is also shown in the table for future reference.

**Table 9** Available Process Information Gathered from Batch Records for the Manufacture of Solution (Drug D) Dosage Form

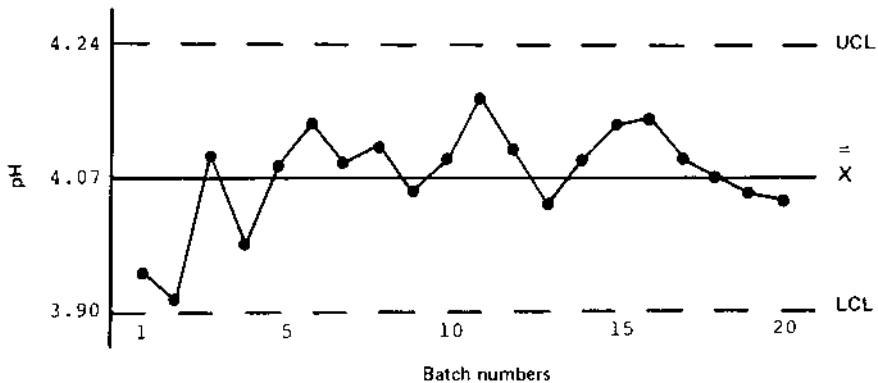
Batch number	Time required for the completion of the step (in hr and min)			Batch yield (%)
	Step A <sup>a</sup>	Step B <sup>b</sup>	Step C <sup>c</sup>	
01	5:00	1:05	1:30	99.10
02	5:00	0:40	1:10	99.20
03	6:00	0:40	1:00	100.10
04	5:00	1:10	1:20	98.50
05	4:30	0:50	1:15	99.20
06	5:00	1:05	1:10	98.90
07	6:00	1:15	1:40	98.95
08	5:30	0:45	1:30	98.50
09	6:00	1:00	1:35	98.60
10	4:30	0:45	1:20	98.87
11	5:30	1:00	1:25	98.81
12	5:45	0:50	1:25	98.70
13	5:00	1:00	1:30	99.20
14	5:00	1:10	1:40	98.95
15	6:00	1:15	1:20	99.02
16	5:00	0:45	1:00	99.40
17	5:00	1:00	1:05	99.50
18	6:00	0:50	1:30	99.10
19	5:00	0:40	1:10	99.48
20	5:00	1:05	1:25	99.30
				$\bar{x} = 99.07$

<sup>a</sup>Step A: Time required to disperse viscosity-building agent in water.

<sup>b</sup>Step B: Time required to dissolve water-soluble formulation ingredients in water.

<sup>c</sup>Step C: Time required to dissolve alcohol-soluble formulation ingredients in alcohol.

Product appearance was unremarkable. The pH was examined using a control chart. Because this is a single point observation, the moving range method was employed. The chart disclosed that the process operates within the calculated control limits. No trends were apparent. Individual batch results all met specification, and the process average (4.07) is close to the target value of 4.10. (See Fig. 11.)

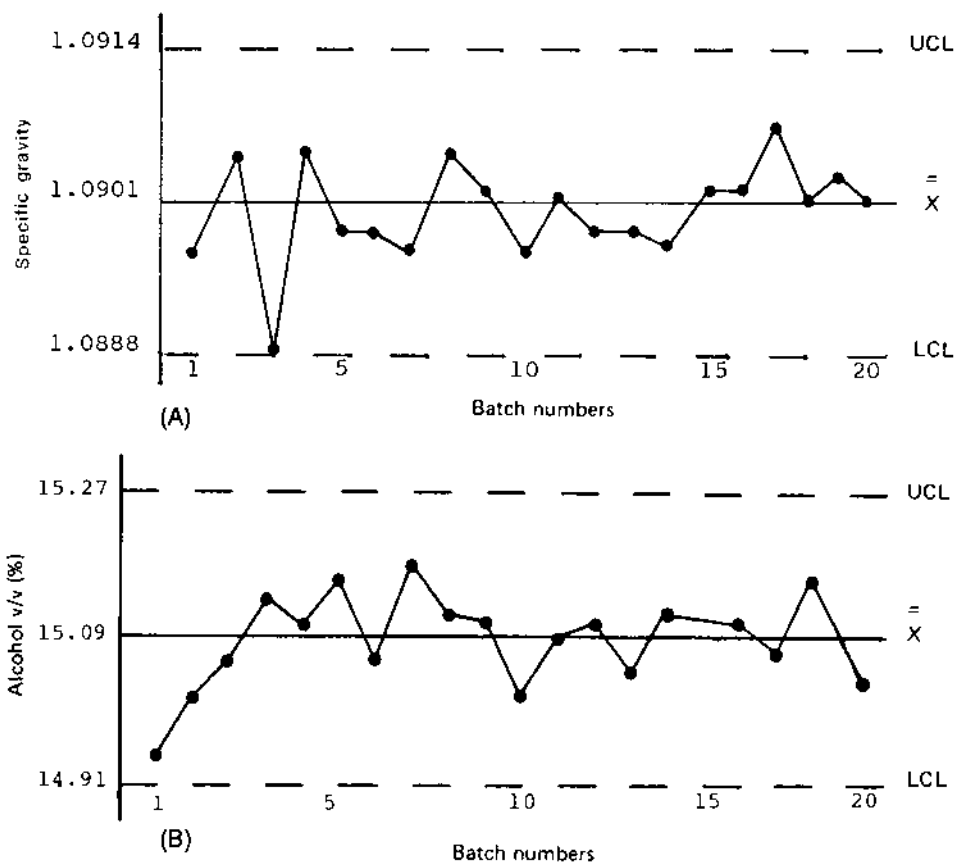


**Figure 11**  $\bar{x}$ -control chart of pH using moving range method for drug D.

The mean specific gravity for this 20-batch study is 1.091, the midpoint of the specification range. The control chart for this variable was prepared by the moving range method (Fig. 12). The calculated UCL and LCL (1.0914 and 1.0888, respectively) are within the product's specification limits. Individually, all batches met specification. The specific gravity of batch 3 is at the lower control limit. A plausible explanation for this can be found in the bulk yield (Table 9), which is 0.1% greater than theory and 1.03% in excess of the average for this study, hence "overdiluting" the batch during manufacture is a possible explanation. The alcohol concentration of batch 3 should be compared to the 20-batch mean to determine whether or not this step was the cause.

The alcohol content averaged 15.09%, or 0.09% above target. Individual batches met specification in every instance. The control chart (Fig. 12) was unremarkable in terms of trends or tests for pattern instability. Batch 3 is slightly below the process average, effectively ruling out overaddition of alcohol as a factor in the low specific gravity previously observed.

The concentration of active ingredient D1 for batch to batch is shown in Figure 13. The mean potency of all batches is 0.1 mg/5 ml above target. The control chart did not respond to tests for unnatural patterns and trends. It is noteworthy that the calculated UCL (16.7 mg/5 mL) for the 20 batches in this study exceeds the release specification for the product (15.5 to 16.5 mg/5 ml). A probability thus exists that a batch may eventually fail to meet the release criteria. Raw material purity is not a factor in the potency of an individual batch because it is taken into consideration at the time of manufacture. A possible explanation for the wide historical control limits is the assay methodology for

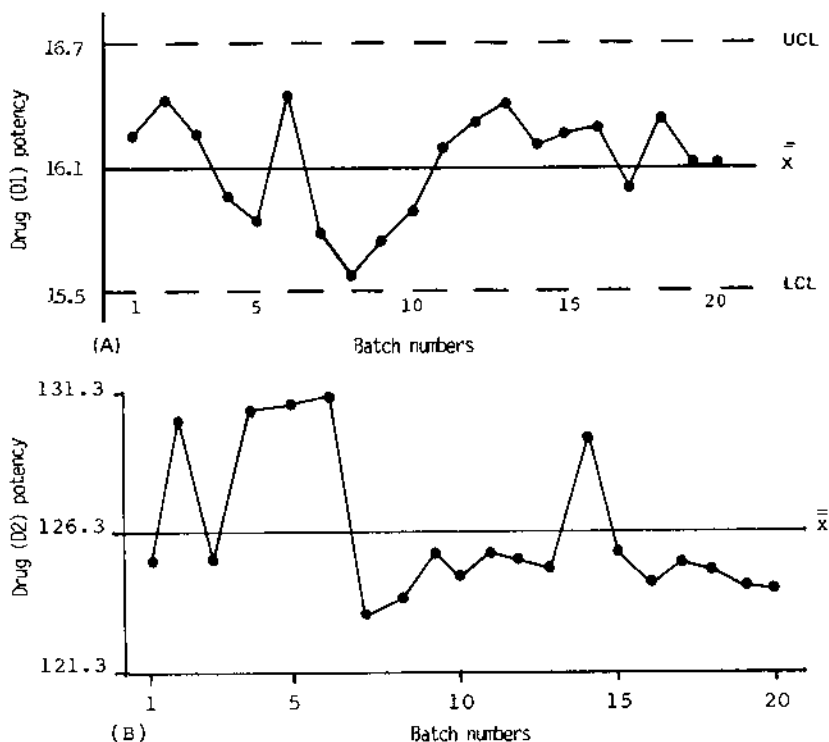


**Figure 12** (A)  $\bar{x}$ -control chart for drug D specific gravity using moving range method. (B)  $\bar{x}$ -control chart of drug D alcohol percent (v/v).

D1. As a starting point, the next 20 production batches could be monitored for this variable to see whether or not the condition persists.

Assay results for active ingredient D2 individually met specification. The 20-batch average was 126.3 mg/5 ml, or 1.3 mg/5 ml in excess of target. Inspection of the  $\bar{x}$ -control chart for this variable (Fig. 13) discloses an atypical pattern; that is, batches 1 to 6 have distinctly greater potency than batches 7 to 20, with the exception of batch 14. The bimodality of the data is readily apparent when batch 14 is disregarded. The phenomenon can be explained by a change in assay method from ultraviolet (UV) to high performance liquid chromatography





**Figure 13** (A)  $\bar{x}$ -control chart for drug D1 potency. (B)  $\bar{x}$ -control chart for drug D2 potency.

(HPLC), commencing with batch 7. Further investigation revealed that the UV procedure was used for batch 14 as well, in this instance because the HPLC instrument was out of service. With the two populations properly grouped, consistency of the HPLC method to detect ingredient D2 becomes apparent. (See Table 10.)

Eleven receipts of active ingredient D2 were used to compound the batches included in the study. Lot purity ranged from 99.5–101.1%; the average was 100.4%. Purity of the raw material receipt was not seen to have an affect on the potency of the batch(es) in which it was used. This is probably due to the occasional need to use more than one receipt to compound a batch.

In summary, the study demonstrates the wisdom of switching to an HPLC method for finished bulk approval. It also raises questions about the reproducibility of the assay for drug D1, which should be investigated, otherwise no

**Table 10** Drug D: Comparison of UV and HPLC Assay for Active Ingredient D2

Statistic	Test method	
	UV	HPLC
N	7	13
$\bar{x}$	129.07	124.79
s	2.44	0.70

recommendation for change in the method of operation can be made based on historical results from selected manufacturing steps and control tests. Furthermore, with a better understanding of the cause of drug D1 potency variability, it is not unreasonable to conclude future production will continue to meet specifications.

### E. Semisolid Dosage Form (Drug E)

The product we have selected for examination is an emulsion cream of the oil-in-water type. We will refer to this product as drug E. The directions for manufacture call for addition of the active ingredient to a methylcellulose solution, followed by addition of an humectant.

Heat is applied with continued mixing until a specified temperature is reached. Consistency is then increased through the introduction of several viscosity-building agents. Occlusives and preservatives are then incorporated. The batch is held with agitation at this temperature for several min and then cooled with varying rates of agitation to prevent air entrapment.

Table 11 lists the critical process steps that should be considered for evaluating batch-to-batch uniformity. Although other information such as melting

**Table 11** Drug E: Selected Critical Process Steps and Quality Control Tests

Process steps	Quality control tests
Rotational speed of the inner and outer sweep blades during processing	Appearance pH
Total time required to increase the batch temperature to 65°C	Assay
Time required to achieve batch cool-down (65–35°C)	Specific gravity Penetrometer reading Microbial contents

time for waxes is available from the batch record, those were not thought to be critical.

Also included in [Table 11](#) are six tests routinely performed by the quality control department on a sample of the bulk. The sample is obtained about midway during transfer of the bulk from the make tank to the storage totes. The appearance of the product was selected as an indicator of filter performance. A stable pH, within specification, is essential to preclude degradation of active ingredient and obviate dermal irritation. Specific gravity, which is a measure of the amount of suspended solids, indicates that all formulation ingredients have been incorporated. Penetrometer readings measure the consistency of the cream, which may affect the ability to package the product as well as acceptance by the patients. Microbial content is determined routinely in the interest of the safety of the patients as well as product efficacy. Finally, the assay of the active ingredient is selected as a measure of the efficiency of the process to distribute the drug uniformly.

## 1. Evaluation of Historical Data

A review of the records for 20 batches shows that the rotational speed of the inner and outer sweep blades in the manufacturing vessel is always set at 24 to 20 rpm, respectively, during the heating cycle. Statistical treatment was therefore considered inappropriate. During the cooldown cycle, the batch record specifies rotational speeds of inner and outer sweep blades. It also allows the operator to change the agitator speeds to prevent aeration and instructs the operator to record any such changes. The review shows that no adjustments were necessary. Because of the consistency of the operation from batch to batch, no statistical treatment of the available data was deemed necessary.

The time required to increase the batch temperature to 65°C was studied. Of the 20 batches, 18 required 35 min, while the other two batches attained the desired temperature in about 30 min. Such small differences were not thought important enough for further evaluation. The time required for the cooldown cycle was found to be 65 min for 16 batches, while four batches took 60 min. Final product characteristics, such as appearance and penetrometer readings, were compared for batches with cooling times of 60 and 65 min, and no difference was found in the end product.

Data collected from the quality control tests were evaluated next. The assay for active ingredient varied from 19.60–19.90%, indicating a yield of 98–99.5% of the original quantity added. Some of this loss is assignable to the purity of the raw material active ingredient, which ranged from 99–100%. These assay values also indicate that the active ingredient is well distributed in the cream, and that loss of the active ingredient during the various processing steps is negligible. The specific gravity of the batch varied from 1.120 to 1.126, a

good indication that the level of solids from batch to batch is consistent. The pH of the end product varied from 5.4 to 5.9. This variability may be partly attributed to the difference in pH of the excipients and/or the deionized water used. Unfortunately, the pH of purified water was not always available for the date on which a batch of drug E was compounded. Similarly, pH is not a routine quality control test for several of the excipients, thus further investigation was not possible.

Data from the quality control tests for the various parameters selected were used to prepare control charts. These control charts were then analyzed for any evidence of instability or unnatural pattern. None was detected.

A microbial limit test was performed on a routine basis and the 20 consecutive batches each showed conformance to specifications.

One recommendation arises from the review of this product. The rotational speeds of the agitator were remarkably constant during the heating cycle and therefore should be included in the written instructions for future batches; otherwise, the process is considered validated.

#### **IV. COMPUTER-AIDED ANALYSIS OF DATA**

Once the mechanics of retrospective validation are mastered, a decision is required as to how data analysis will be handled. The illustrated calculations may be performed manually with the help of a programmable calculator and the control charts may be hand-drawn, but computer systems are now available that can shorten the task. If the computer route is chosen, commercially available software should be considered. There are many reasonably priced programs that are more than up to the task [17].

Before beginning data analysis, the following issues should be considered:

1. The vertical scale has to be chosen carefully to accommodate both control and specification limits. The latter may have to be entered manually to avoid unreasonable compression of the chart.
2. Care must be taken that tables and graphics are fully identified as to product name and the variable(s) under review.
3. Manual examination of some information should be anticipated. The output will have to be interpreted and related to other factors that may not be part of the database. Nonnumerical information is an example.

Figure 14 illustrates the construction of a table containing the results of end-product testing of 22 batches of a tablet dosage form. For simplicity, the product will be referred to as drug F. There are 22 rows and 14 columns, for a total of 308 data points. Each column has an abbreviated heading that describes the information contained therein. The headings are not needed for computer

Laboratory Results			Drug F				
0	1 Batch	2 Form	3 LOD	4 $\bar{x}$ Diss AI 1	5 $\bar{x}$ Diss AI 2	6 ATW	7 Hardness
1	8B10	M210	0.3	97.1	91.5	455.6	12.9
2	8B11	M210	0.4	97.2	96.8	457.0	10.3
3	8D10	M210	0.4	98.3	96.4	456.0	18.7
4	8D11	M210	0.3	98.2	97.3	457.4	18.7
5	8E10	M210	0.5	96.4	94.6	456.0	14.6
6	8E11	M210	0.3	98.0	89.0	455.7	14.3
7	8G10	M210	0.5	99.5	91.4	458.0	12.9
8	8G11	M210	0.4	98.1	90.3	454.4	12.9
9	8H10	M210	0.5	100.3	86.3	456.9	15.1
10	8H11	M210	0.5	100.3	99.3	459.8	15.3
11	8H12	M210	0.7	99.5	100.0	457.7	14.8
12	8K10	M210	0.7	101.2	101.6	458.5	13.8
13	8L10	M210	0.5	101.3	99.8	457.1	15.6
14	8L11	M210	0.3	101.6	99.1	457.1	12.9
15	8L12	M210	0.2	97.7	97.5	457.8	11.3
16	9D10	M210	0.3	96.2	95.9	458.4	14.1
17	9D11	M210	0.3	98.7	96.8	456.6	12.2
18	9E10	M211	0.5	97.3	90.6	457.1	15.3
19	9I10	M211	0.6	97.1	92.5	456.6	13.7
20	9J10	M211	0.4	98.7	91.1	456.6	18.0
21	9J11	M211	0.7	87.1	88.3	456.2	10.5
22	9K10	M211	0.4	98.9	95.2	457.6	11.3

0	8 %FRIAB	9 $\bar{x}$ Asy AI 1	10 $\bar{x}$ Asy AI 2	11 Method AI 2	12 DU AI 1	13 DU AI 2	14 Bulk Capped
1	0.8	224.5	102.9	1	1.7	1.3	0
2	0.9	220.9	102.7	1	1.3	1.6	0
3	0.7	226.5	104.5	1	2.1	1.2	1
4	0.8	225.2	104.8	1	1.6	1.1	0
5	1.0	221.0	106.8	2	2.2	2.0	0
6	0.7	220.6	101.4	2	1.6	1.4	1
7	0.7	220.8	99.6	2	1.3	2.0	0
8	6.5	219.4	102.1	1	1.8	2.1	2
9	0.9	219.5	102.9	1	1.8	2.1	0
10	0.8	221.4	100.7	1	1.4	1.5	0
11	0.7	221.7	98.4	1	1.3	1.0	0
12	0.8	227.8	105.8	1	1.7	1.6	0
13	5.8	226.5	101.4	1	1.1	1.7	0
14	5.9	228.5	103.3	2	2.0	1.2	1
15	7.5	230.7	107.4	2	1.6	1.3	2
16	0.7	219.7	103.7	2	1.1	1.0	0
17	0.7	220.6	104.1	2	1.5	1.3	0
18	0.8	222.1	106.3	2	2.1	1.5	0
19	1.9	217.6	103.7	2	2.7	2.4	0
20	0.7	222.3	99.2	2	1.3	1.2	0
21	0.8	220.3	97.4	2	1.7	2.3	3
22	0.9	223.5	98.7	2	2.1	0.8	0

**Figure 14** Drug F: product release test results organized for computer analysis.

analysis, but make manual review possible. The 22 batches, one per row, have been assigned a reference number (1 to 22) to simplify control chart preparation. The batch and formula numbers are listed next for information only, in the event that further manual investigation of a conclusion is deemed appropriate. Columns 3 through 12 (except 11) contain mean results for tests performed by the laboratory: percentage of LOD, dissolution (for two active ingredients), ATW, hardness, percentage of friability, assay, and dose uniformity (DU). Column 11 describes the assay method employed for active ingredient 2. The number 1 was assigned to the UV assay procedure, and the number 2 refers to the HPLC method. This is one solution for including nonnumerical information in the database. Column 14 lists the results of the inspection for capped tablets. The numbers shown reflect the actual number of capped tablets recovered from a random sample of a given size. Figure 14 could easily be expanded to incorporate other variable information, such as observations about critical process steps, which might be needed for the validation.

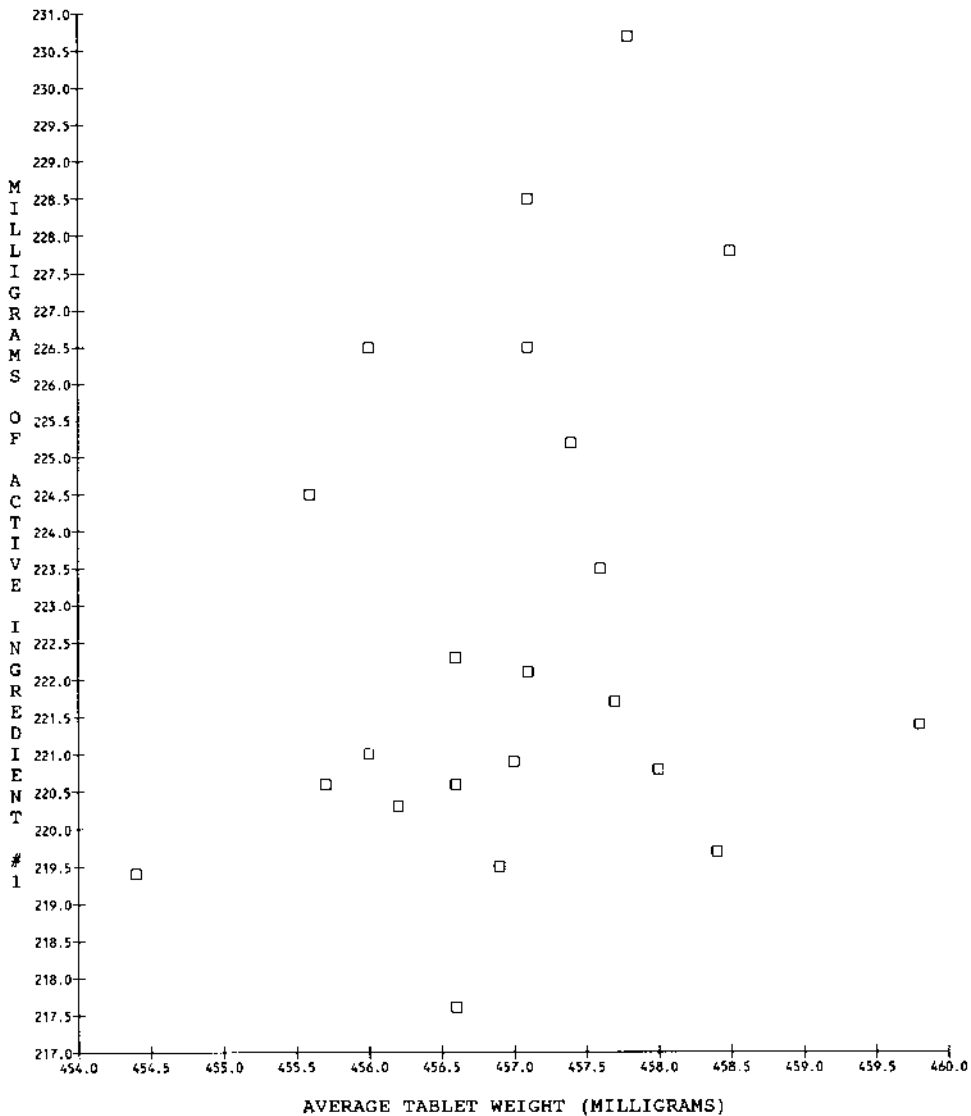
Data analysis would normally commence with the calculation of means and standard deviations for each column of numbers where this was appropriate. Next, tests would be performed to establish whether or not the data were normally distributed. The data could then be grouped according to a particular variable (e.g., year of manufacture, oscillator screen size, or assay method) and compared statistically for differences between the mean and standard deviations. For ease of review by the validation team, a table should be printed summarizing the statistics calculated and the conclusions reached as a result of these data manipulations.

Graphical methods are powerful tools for extracting the information contained in data sets and making statistical conclusions easier to understand. A variety of techniques have been developed in recent years. An excellent overview of these methods is given by James and Polhemus [18].

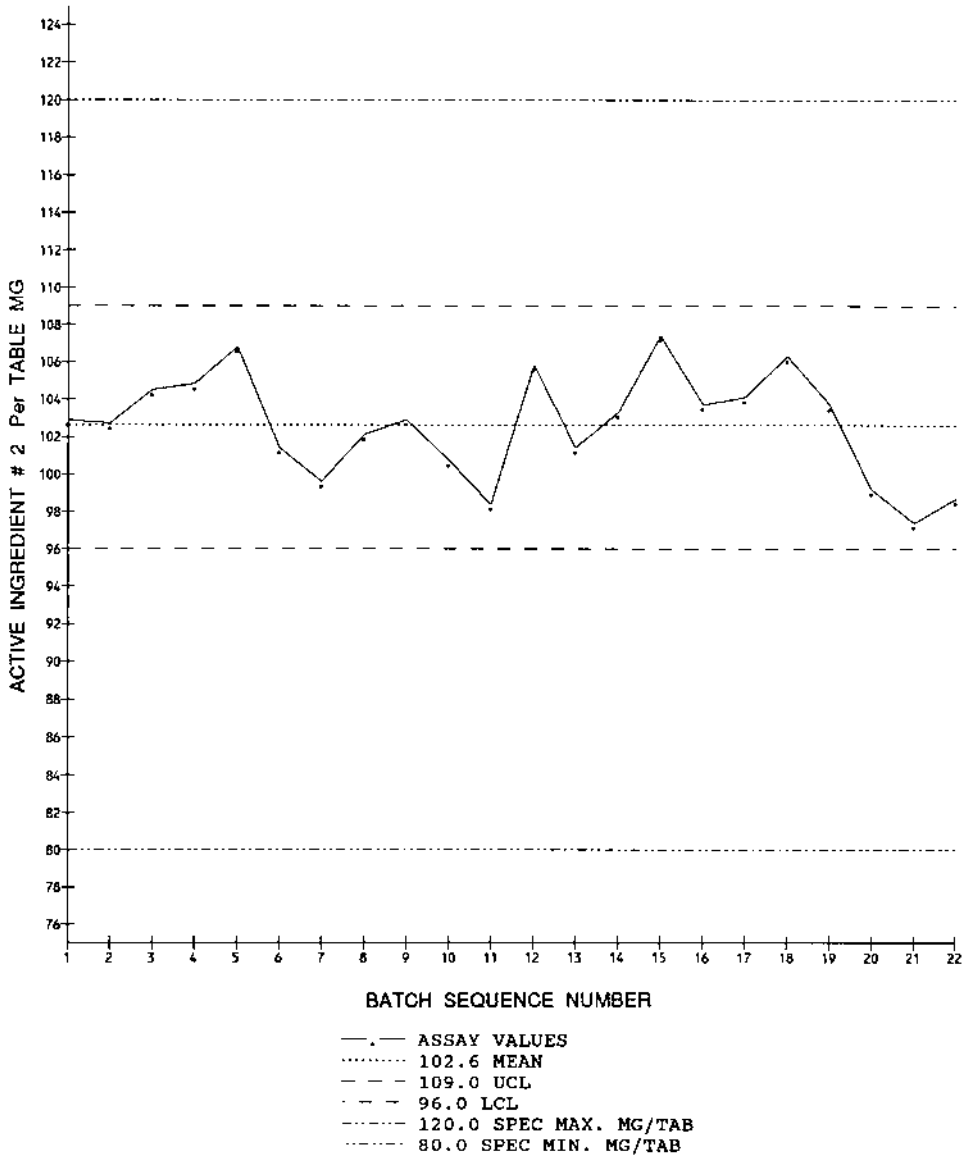
Figure 15 is a scatter plot of ATW versus assay using data from columns 6 and 9 of Figure 14. It was prepared using commercially available software. The scatter plot enables the reviewer to visualize the relationships among two or more product characteristics.

Control charts similar to the hand-drawn ones used earlier to illustrate the evaluation of processing data are also easily prepared using readily available software. Figure 16 is an  $\bar{x}$  chart of tablet assay for active ingredient 2. Note that minimum maximum specification limits have been included. Figure 17 depicts a traditional  $\bar{x}$  control chart for dissolution to which error bars have been added to denote individual tablet assays for each batch.

Regression analysis requires that a new table be constructed listing the individual tablet weight (column 1), corresponding assay (column 2), and percentage of purity of the raw material used to compound the tablet (column 3). From these data, regression lines and confidence intervals can be plotted to complement the usual statistics.

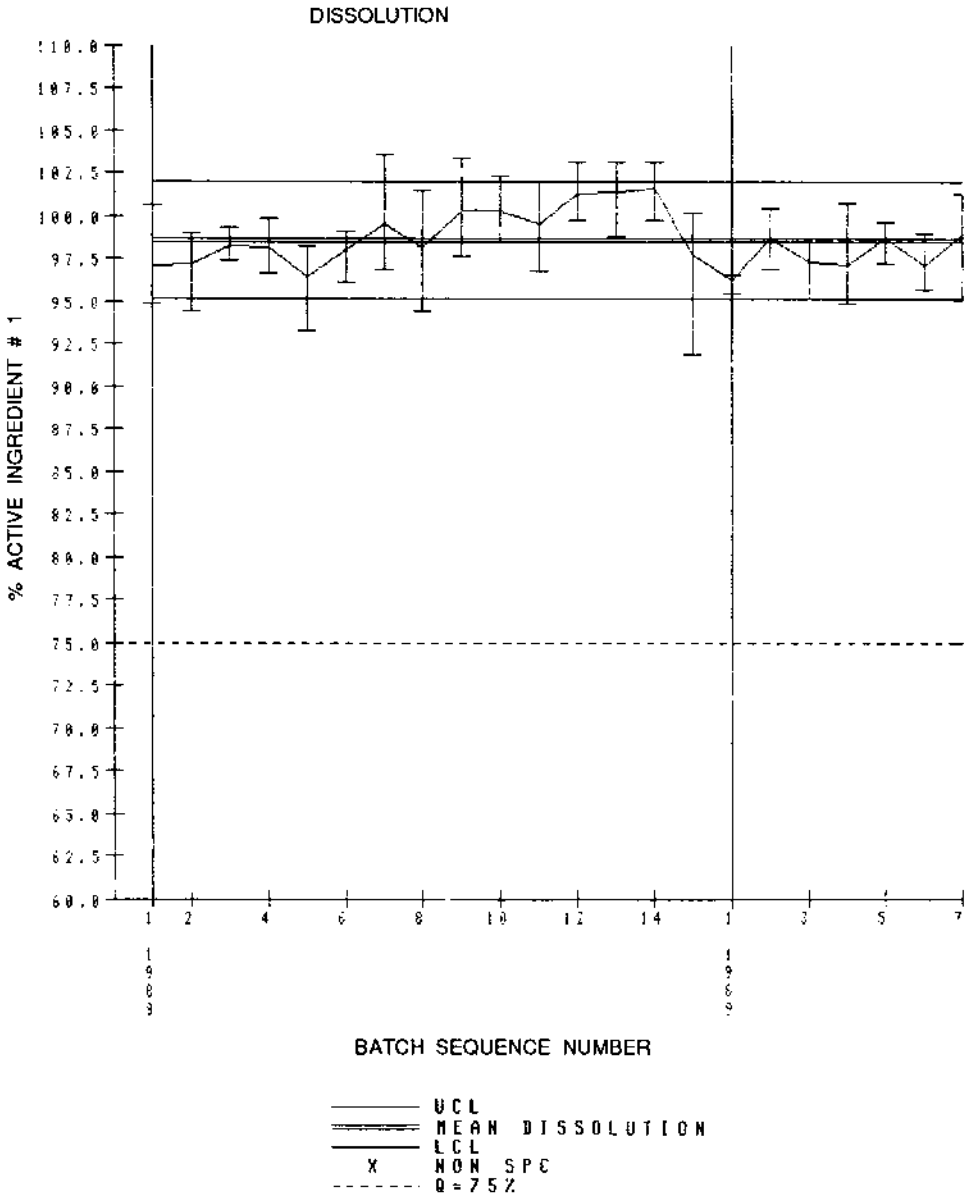


**Figure 15** Drug F: computer-generated scatter plot of ATW vs. assay (AI 1).



**Figure 16** Drug F: computer-generated  $\bar{x}$ -control chart of tablet assay (AI 1).





**Figure 17** Drug F: computer-generated  $\bar{x}$ -control chart of tablet dissolution (AI 1) with tablet assay error bars.

## V. USING VALIDATION EXPERIENCE TO SET PRODUCT ALERT LIMITS

Experience gained during validation can be used to fine-tune the process for greater reliability. Several examples of changes being recommended based on study findings may be found in the section of this chapter devoted to evaluation of process data. Another application of the information gathered during validation is in setting alert limits to be incorporated into the mechanism for product release. The alert limits would be the control limits (UCL and LCL) calculated as part of the review process for each analytical test; they could be made part of the written specifications for product release.

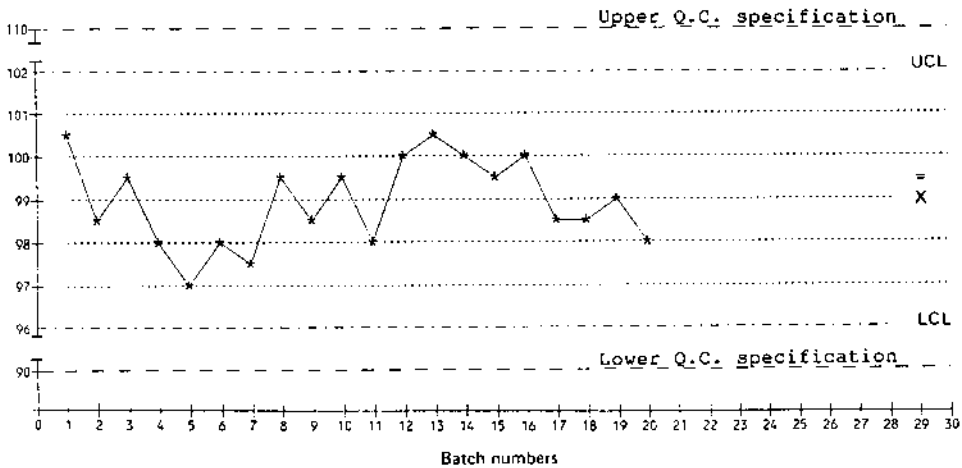
The recommendation to use control limits calculated as part of validation as alert limits is based on the expectation that test results from future production should normally fall within these limits. Indeed, this is the essence of retrospective validation. Furthermore, for a stable, centered process the control limits would fall within the release specification for the test. Exceeding an alert limit therefore would not necessarily delay product release but could precipitate an investigation into the cause.

Requiring quality control to use validation experience to release product achieves two objectives: it monitors conclusions reached during validation for ongoing reliability and identifies a trend early before a rejection occurs. For quality control laboratories using a laboratory information management system (LIMS), routine performance of test result-alert limit comparisons can be automated. Where such a system is not available, manually recorded test results could be transferred to a stand-alone computer for trend analysis. An  $\bar{x}$  plot depicting the process in relation to the alert and specification limits should be considered for monitoring trends. See [Figure 18](#) for an example of such a plot.

## VI. RELIABILITY OF THE VALIDATED PROCESS

Once the process has been validated, controls must be put into place to make certain that operations continue to be performed as originally described. It is unreasonable to assume that machines, instruments, plant services, and personnel will remain static indefinitely. The FDA recognized the need for revalidation when it issued the process validation guidelines [1]. A number of resources are available to monitor for process drift. The quality assurance department can perform periodic audits of manufacturing and laboratory practices against official procedures, review equipment maintenance records including calibration history, and examine personnel training programs. Any departures from original assumptions must be brought to the attention of the validation team for evaluation of their impact on the process.

The CGMPs require the manufacturer of a product to conduct an annual review of written records to evaluate product quality [6]. A number of authors



**Figure 18** Computer-generated  $\bar{x}$ -control chart showing relationship of historical control limits (UCL and LCL) and quality control release specifications.

have suggested that when done properly the review can highlight trends that might otherwise go unnoticed. Lee discusses how analytical and production data, as well as product complaint experience, can be arranged or collated for this purpose [19]. The annual review would be an expedient means of monitoring the conclusions reached during validation.

When planned changes are made to the process, equipment, or immediate operating environment, the validation team should carefully assess the nature of the change for its impact on different aspects of the process. It may not be necessary to revalidate the entire process in cases in which the change can be shown to be isolated [1]. There may be an opportunity to supplement the historical experience with a prospective study specific to the planned change. To ensure that this review occurs, a formal change control system must be in place. It would also be appropriate to have in place a written plan describing the company functions that have responsibility for monitoring the process.

## VII. SELECTION AND EVALUATION OF PACKAGING DATA

To this point retrospective validation has been discussed in the context of dosage form manufacture. Some of the same concepts may be applied to validating a packaging operation. Consider the following. Packaging lines are typically controlled by making spot observations to confirm machinery performance and

component usage. The frequency of the inspections and the number of samples examined during each cycle are normally defined in a written procedure. Furthermore, the results of each monitor are generally documented in an inspection report, which becomes part of the packaging record for that lot of product. Also available from the packaging record is the number of units produced, thus the information needed to allow inferences about the reliability of a particular operation is readily accessible.

If we can show that over an extended period of time an operation had a certain reliability, it is not unreasonable to expect the same level of performance for the future as long as the equipment is reasonably maintained. Conversely, any conclusion reached by such a study would be invalidated by substantial change to the equipment or its method of operation.

How many packaging runs must be examined to draw a sound conclusion about the reliability of the operation? Unfortunately, no one answer is appropriate for every situation, but there are some rules that will aid the decision process. The sample size should be large enough to capture all variables normally experienced; for instance, routine machine problems, shift and personnel changes, component vendor differences, and seasonal conditions. Furthermore, the sample must be of sufficient size to provide a high degree of confidence in the conclusion. Ten thousand observations made over 6 to 12 months of continuous production generally satisfy these requirements. For high-speed, multiple-shift operations the 10,000-observation figure is likely to be reached well before sufficient time has elapsed to include all avenues of variability. In these cases, time rather than units produced should be the first consideration.

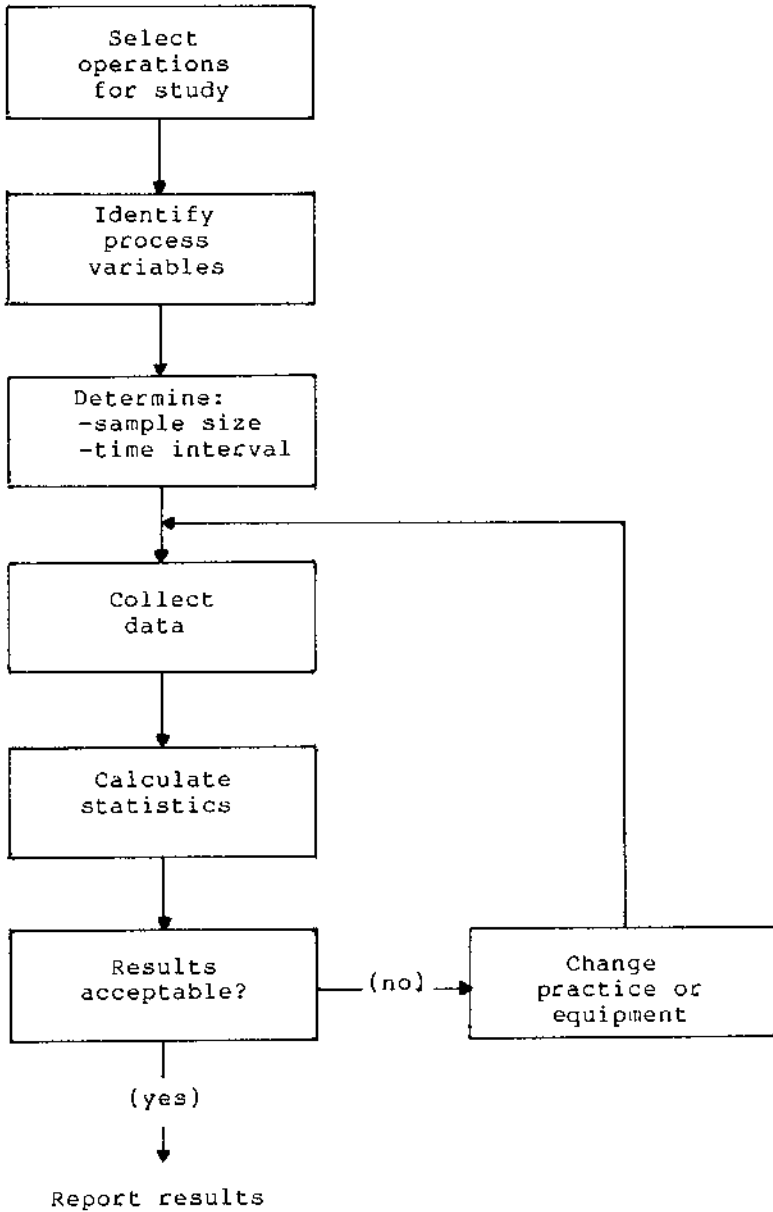
To validate an aspect of the packaging operation retrospectively the following information must be tabulated:

1. The total number of observations made for the quality attribute under review
2. The total number of nonconformances detected by the inspection process

Figure 19 summarizes the retrospective validation strategy for a packaging operation. It also takes into consideration an opportunity for process improvement. For example, we may learn from the study that a particular operation has a defect rate that in our judgment is unreasonably high. The effectiveness of remedial action could be evaluated after a suitable period of time has elapsed by repeating that phase of the validation study. In addition, the information provided by the study about machine and operator dependability permits informed replies to inquiries by customers or the FDA about alleged package defects.

## **A. Sources of Historical Information**

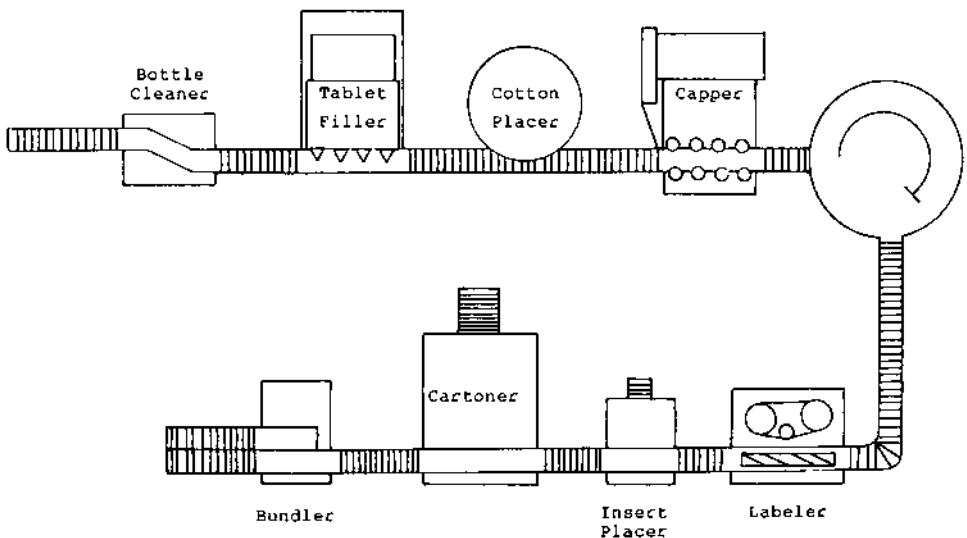
A specific example can serve to illustrate how validation may be accomplished. A typical high-speed packaging line for solid dosage form products consists of



**Figure 19** Packaging operation validation strategy.

several pieces of specialized machinery, usually in series, connected by a moving belt (see Fig. 20). When the line is operational, there is a roving inspection designed to evaluate the performance of each piece of equipment. For example, at the labeler the inspector would be asked to confirm that the serial number on the label matches the work order, that the correct lot number and expiration date appear on the label, and that the label is properly adhered to the bottle. The outcome of each inspection is recorded. In the event nonconformance is observed, packaging supervision is notified. Remedial action may take the form of a machine adjustment and/or isolation and removal of nonconforming production. These roving inspections have the effect of limiting the number of defectives that reach the finished goods stage.

In addition to the roving inspection, a finished piece inspection is performed each half hr; that is, the inspector randomly selects for examination one finished unit from the end of the line. In our example, the finished unit is a unitized bundle of 12 bottles of 100 tablets each. Each finished piece is torn down into its component parts, which are examined for specific attributes and conformance to the work order. Table 12 summarizes the tests made by the inspector, as well as the number of pieces examined at each half-hr interval. When nonconformance is detected, a notation is made in the inspection record. With 13 finished product audits performed on each shift, a considerable pool of information is readily amassed.



**Figure 20** Typical layout for high-speed solid dosage form packaging line.

**Table 12** Finished Product Audit: Package Attributes and Number Examined

Attribute	Number examined		
	Each audit	Each shift	Each year
Intact bundle	1	13	1,300
Carton	12	156	15,600
Outsert	12	156	15,600
Bottle	12	156	15,600
Label	12	156	15,600
Lot number			
Expiration date			
Adhesion			
Cap	12	156	15,600
Seal			
Tablet count <sup>a</sup>	4	52	5,200

<sup>a</sup>Tablet count is performed on only four bottles. The annual figure is based on 100 shifts.

Because we are interested in line machinery and package attributes and not the drug product being packaged, inspection results for all 100-tablet bottle runs may be pooled. One could even argue convincingly that the type and number of doses in the bottle are of no import as long as the line configuration remains constant. In any event, the pooling of production volume as well as inspectional observations substantially accelerates data accumulation. This may be an important consideration in cases in which a particular packaging line is used for multiple products and sizes.

The line to be studied runs 100 shifts per annum of a particular package size at the rate of 50,000 bottles per shift; thus, in 1 year 5 million bottles are produced. During the same period, between 1300 and 15,600 inspectional observations are made, depending on the attribute (Table 12).

## B. Estimating Outgoing Product Quality

The remaining task is to count the number of defects for each attribute as reported by the inspector during the course of the year following the finished piece inspection. This task is more time-consuming than difficult, assuming line inspection documents are well organized. The outcome is reported in Table 13. With this information available, the maximum fraction defective at a preselected

confidence level may easily be estimated. The figures in Table 13 are derived from the Poisson approximation rather than the normal approximation to the binomial, which is adequate for this purpose [20].

According to Table 13, the cap was present for each bottle sampled; however, the lip seal was not fully adhered in 16 instances. The proportion of defectives in the samples is 16/15,600 or 0.001 (0.1% or 1/1000). The maximum fraction defective for an incomplete lip seal in the population (production lots) is 0.0018 at the 99% confidence level. Stated another way, there is 99% assurance that the number of bottles with an incompletely adhered seal will not exceed two units for every 1000 produced. The value has been calculated for the other quality attributes to illustrate the impact of the sample size and the different levels of machine performance on lot defectives.

Calculating the maximum fraction defective for important package attributes provides a clear picture of the quality of goods sent to the customer as well as machine capability. If the defect rate is uncomfortably high, an investigation can be made to identify the cause. Possibly the solution is to modify a practice or replace a particular item of equipment.

## VIII. CONCLUSION

Under certain conditions, a firm may rely on existing production, quality control, and facilities maintenance information, and consumer input to validate retrospectively the processes of marketed products. The end result of this effort

**Table 13** Inspectional Results and Fraction Defective

Attribute	Number of samples examined	Number of observed defects	Maximum fraction defective at 99% confidence limit
Intact bundle	1,300	11	16.5/1000
Carton	15,600	0	0.3/1000
Outsert	15,600	7	1.0/1000
Bottle	15,600	0	0.3/1000
Label	15,600	0	0.3/1000
Lot number		1	0.4/1000
Expiration date		2	0.51/1000
Adhesion		5	0.8/1000
Cap	15,600	0	0.3/1000
Seal		16	1.8/1000
Tablet count	5,200	3	1.9/1000



is the ability to predict with a degree of confidence the quality of subsequent batches. Furthermore, familiarity with the product acquired through such in-depth study can lead to process improvement, which in turn enhances overall control. The knowledge acquired and data amassed during retrospective process validation provide a performance profile against which daily release testing can be compared, to say nothing of their value as a guide when resolving production and control problems. Process validation is a CGMP requirement, and therefore an area of interest to the FDA. The program just discussed is one approach to satisfying this requirement. The chapter also extends the concept of using historical data to predict future performance of packaging operations.

## REFERENCES

1. Food and Drug Administration. *Guidelines on General Principles of Process Validation*. Rockville, MD: Division of Manufacturing and Product Quality (HFN-320), Office of Compliance, Center for Drugs and Biologics (May 1987).
2. Brands of the century. *Med Ad News* 54–59 (Jan. 2000).
3. Ellsworth, D. FDA Field Report. NDMA Manufacturing Controls Seminar, Philadelphia, Oct. 8–9, 1998.
4. Schilling, E. *Acceptance Sampling in Quality Control*. 10th ed. New York: Marcel Dekker, p. 7 (1982).
5. Estes, G. K., Luttsell, G. H. An approach to process validation in a multiproduct pharmaceutical plant. *Pharm Tech* 76–77 (April 1983).
6. Food and Drug Administration *Current Good Manufacturing Practices in Manufacture, Processing, Packaging and Holding of Human and Veterinary Drugs*. Federal Register, vol. 43, no. 190, U.S. Government Printing Office, Washington, D.C. (Sept. 1978).
7. Avallone, H. E. Retrospective validation. NAPM Meeting, Port Chester, NY, Sept. 1983.
8. Sadek, H. M. Considerations for achieving content uniformity in solid/solid blending. *Pharm Mfg* 18–21 (March 1985).
9. Western Electric Company. *Statistical Quality Control Handbook*. 6th ed. Easton, PA: Mack (1982).
10. Food and Drug Administration. *Guidance for Industry, ANDAs: Blend Uniformity Analysis*. Rockville, MD: Center for Drug Evaluation and Research (Aug. 1999).
11. Food and Drug Administration. *Guide to Inspection of Oral Solid Dosage Forms: Pre/Post Approval Issues for Development and Validation*. Rockville, MD: Office of Compliance, Center for Drugs and Biologics (Jan. 1994).
12. Johanson, J. R. Predicting segregation of bimodal particle mixtures using the flow properties of bulk solids. *Pharm Tech* 46–57 (May 1996).
13. Juran, J. M., Godfrey, B., eds. *Juran's Quality Handbook*. 5th ed. New York: McGraw-Hill, Sec. 44 (1999).
14. Kieffer, R., Torbeck, L. Validation and process capability. *Pharm Tech* 66–76 (June 1998).

15. Hwang, R., Hwang, Y., Peck, G. R. Evaluation of blend sampling errors: A statistical approach. *Pharm Tech* 56–66 (June 1999).
16. Berry, I. R. Process validation for soft gelatin capsules. *Drug Cos Ind* 26–30 (April 1984).
17. 1999 statistical process control software buyers guide. *Qual Digest* 19(12): 51–64 (1999).
18. James, P. D., Polhemus, N. W. Graphical methods for quality achievement. ASQC Quality Control Congress, San Francisco, 1990.
19. Lee, J. Product annual review. *Pharm Tech* 86–92 (April 1990).
20. Pearson, E. S., Hartley, H. O. *Biometrika Tables for Statisticians*. vol. 1, Table 40. London: Cambridge University Press (1962).

# 4

## Sterilization Validation

**Michael J. Akers**

*Baxter Pharmaceutical Solutions, Bloomington, Indiana, U.S.A.*

**Neil R. Anderson**

*Eli Lilly and Company, Indianapolis, Indiana, U.S.A.*

### I. INTRODUCTION

Sterile products have several unique dosage form properties, such as freedom from micro-organisms, freedom from pyrogens, freedom from particulates, and extremely high standards of purity and quality; however, the ultimate goal in the manufacture of a sterile product is absolute absence of microbial contamination. The emphasis of this chapter will be the validation of the sterilization processes responsible for achieving this goal.

Unlike many dosage form specifications, the sterility specification is an absolute value. A product is either sterile or nonsterile. Historically, judgment of sterility has relied on an official compendial sterility test; however, end-product sterility testing suffers from a myriad of limitations [1–4]. The most obvious limitation is the nature of the sterility test. It is a destructive test; thus, it depends on the statistical selection of a random sample of the whole lot. Uncertainty will always exist as to whether or not the sample unequivocally represents the whole. If it were known that one unit out of 1000 units was contaminated (i.e., contamination rate = 0.1%) and 20 units were randomly sampled out of those 1000 units, the probability of that one contaminated unit being included in those 20 samples is 0.02 [5]. In other words, the chances are only 2% that the contaminated unit would be selected as part of the 20 representative samples of the whole 1000-unit lot.

Even if the contaminated unit were one of the 20 samples selected for the sterility test, the possibility still exists that the sterility test would fail to detect

the contamination. The microbial contaminant might be at too low a concentration to be detectable during the incubation period or might not grow rapidly enough or at all because of media and incubation insufficiencies.

If microbial growth is detected in a sterility test, this may reflect a false-positive reading because of the problem of accidental contamination of the culture media while performing the sterility test. The problem of accidental contamination is a serious yet unavoidable limitation of the sterility test.

The Food and Drug Administration (FDA) published guidelines pertaining to general principles of process validation [6]. General concepts and key elements of process validation considered acceptable by the FDA were outlined. A major point stressed in the guidelines was the insufficiency of relying solely on end-product sterility testing alone in ascertaining the sterility of a parenteral of a sterile product lot. Greater significance should be placed on process validation of all systems involved in producing the final product.

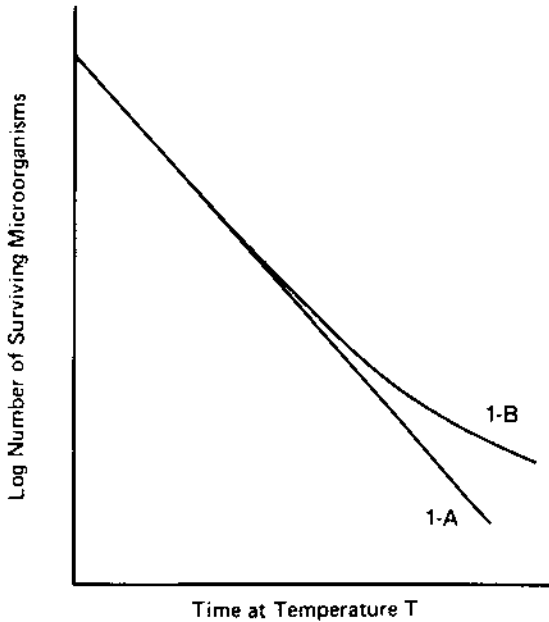
These major limitations demonstrate that reliance on end-product sterility testing alone in ascertaining the sterility of a parenteral product may lead to erroneous results. One purpose of validation in the manufacture of sterile products is to minimize this reliance on end-product testing. Three principles are involved in the validation process for sterile product.

1. To build sterility into a product
2. To demonstrate to a certain maximum level of probability that the processing and sterilization methods have established sterility to all units of a product batch
3. To provide greater assurance and support of the results of the end-product sterility test

Validation of sterile products in the context of this chapter will refer to the confirmation that a product has been exposed to the appropriate manufacturing processes and especially to the appropriate sterilization method yielding a batch of product having a known degree of nonsterility.

## II. PROCESS OF MICROBIAL DESTRUCTION

Regardless of the type of lethality induced by a sterilization process—whether it be heat, chemical, or radiation—micro-organisms, upon exposure to adequate levels of such treatments, will die according to a logarithmic relationship between the concentration or population of living cells and the time exposure or radiation dose to the treatment. This relationship between the microbial population and time may be linear or nonlinear, as seen in [Figure 1](#). The *D* value, or the time or dose required for a one-log reduction in the microbial population, may be calculated from these plots.



**Figure 1** Linear (1-A) and nonlinear (1-B) survivor curves.

### A. *D* Value

The *D* value is a single quantitative expression of the rate of killing of microorganisms. The *D* term refers to the decimal point in which microbial death rates become positive time values by determining the time required to reduce the microbial population by one decimal point. This is also the time required for a 90% reduction in the microbial population. Hence, the time or dose it takes to reduce 1000 microbial cells to 100 cells is the *D* value. The *D* value is important in the validation of sterilization processes for several reasons.

1. It is a specific kinetic expression for each micro-organism in a specific environment subjected to a specific sterilization agent or condition. In other words, the *D* value will be affected by
  - a. The type of microorganism used as the biological indicator.\*

---

\*Biological indicators (BIs) are live spore forms of micro-organisms known to be the most resistant living organisms to the lethal effects of the particular sterilization process. For steam sterilization, the most resistant microorganism is *Bacillus stearothermophilus*. Spore forms of this micro-organism are used as the BI for steam sterilization validation. BIs for other sterilization processes are identified in the USP24/NF19, pp. 231–234.

- b. The formulation components and characteristics (e.g., pH).
  - c. The surface on which the micro-organism is exposed (glass, steel, plastic, rubber, in solution, dry powder, etc.).
  - d. The temperature, gas concentration, or radiation dose of the particular sterilization process.\*
2. Knowledge of the  $D$  value at different temperatures in heat sterilization is necessary for the calculation of the  $Z$  value. (See p. 87.)
  3. The  $D$  value is used in the calculation of the biological  $F$  value. (See p. 87.)
  4. Extrapolation of the  $D$  value from large microbial population values to fractional (e.g.,  $10^{-x}$ ) values predicts the number of log reductions a given exposure period will produce.

$D$  values are determined experimentally by either of two methods, the survivor-curve method or the fraction-negative method [7,8]. The survivor-curve method is based on plotting the log number of surviving organisms versus an independent variable such as time, gas concentration, or radiation dose. The fraction-negative method uses replicate samples containing identical spore populations treated in an identical manner and determining the number (fraction) of samples still showing microbial growth after treatment and incubation. Fraction-negative data are used primarily for determining  $D$  values of micro-organisms exposed to thermal destruction processes. The following discussion concentrates on  $D$  values calculated by the survivor-curve method.

Data obtained by the survivor-curve method are plotted semilogarithmically. Data points are connected by least-squares analysis. In most cases the equation used is the first-order death rate equation,

$$\log N = a + bt \quad (1)$$

where  $N$  is the number of surviving organisms of time  $t$ ,  $a$  is the  $Y$  intercept, and  $b$  is the slope of the line as determined by linear regression. The  $D$  value is the reciprocal of the linear slope,

$$D = \frac{1}{b} \quad (2)$$

Many micro-organisms produce nonlinear survivor curves, such as 1-B in [Figure 1](#). The cause of nonlinear survivor curves has been explained by several theories, such as the multiple critical sites theory [9], experimental artifacts [10], and the heterogeneity of spore heat resistance [11]. Mathematical models for concave survivor curves have been developed by Han et al. [12]. They are quite

---

\*Therefore, stating that the  $D$  value = 1 minute, for example, is meaningless unless all of the above factors have been identified.

complicated. For example, the  $D$  value for a nonlinear survivor curve can be calculated from the following equation:

$$D = \frac{1}{\log C_0} - \frac{[1 - \alpha]t - [\alpha B e^{(-t/B-1)}]}{\log C_t} \quad (3)$$

where  $C_0$  and  $C_t$  are initial and final concentrations of spores,  $t$  is the time exposure at constant temperature,  $\alpha$  is a constant related to the secondary slope of the concave curve, and  $B$  is a parameter obtained from the  $Y$  intercept extrapolated from the second slope. It is far easier, while less accurate, to apply linear regression to fit the survivor curve data statistically to a straight line and calculate the  $D$  value and level of confidence in that calculated value from the slope of the linear line.

A product being validated for sterility should be associated with a characteristic  $D$  value for the micro-organism either most likely to contaminate the product or most resistant to the process used to sterilize the product. The employment of BIs in the validation of sterile products has the purpose of assuring that the sterilization process that causes a multiple log reduction in the BI population in the product will most certainly be sufficient in destroying all other possible viable contaminants.

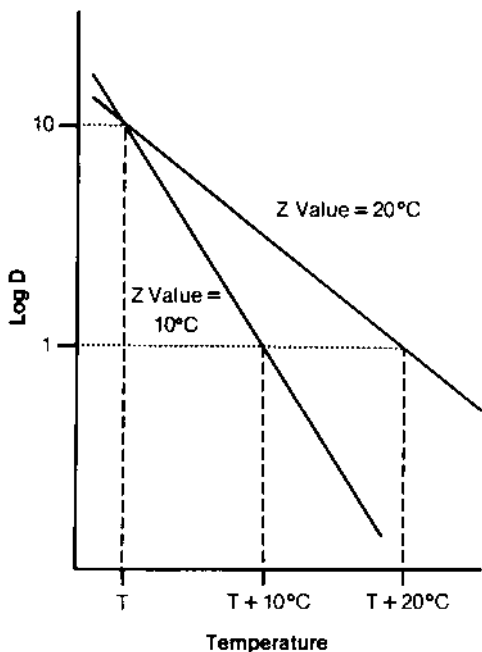
## B. Z and F Values

These terms heretofore have been applied exclusively in the validation of heat-sterilization processes. The  $Z$  value is the reciprocal of the slope resulting from the plot of the logarithm of the  $D$  value versus the temperature at which the  $D$  value was obtained. The  $Z$  value may be simplified as the temperature required for a one-log reduction in the  $D$  value:

$$Z = \frac{T_2 - T_1}{\log D_1 - \log D_2} \quad (4)$$

Figure 2 presents thermal resistance plot for a  $Z$  value of 10°C, the accepted standard for steam sterilization of *B. stearothermophilus* spores, and for a  $Z$  value of 20°C, the proposed standard [13] for dry-heat sterilization of *B. subtilis* spores. These plots are important because one can determine the  $D$  value of the indicator micro-organism at any temperature of interest. In addition, the magnitude of the slope indicates the relative degree of lethality as temperature is increased or decreased.

Mathematical derivation of the  $Z$  value equation permits the calculation of a single quantitative expression for effective time exposure at the desired temperature for sterilization. The  $F$  value measures equivalent time, not clock time, that a monitored article is exposed to the desired temperature (e.g., 121°C).  $F$  values are calculated from the following equation:



**Figure 2** Thermal resistance plots of log  $D$  versus temperature, showing slopes equivalent to  $Z = 10^\circ\text{C}$  and  $Z = 20^\circ\text{C}$ .

$$F = \Delta t \sum 10^{(T-T_0)/Z} \quad (5)$$

where  $\Delta t$  is the time interval for the measurement of product temperature  $T$  and  $T_0$  is the reference temperature (e.g.,  $T_0 = 121^\circ\text{C}$  for steam sterilization). The  $F$  value is shown in Figure 3. Another equation for the  $F$  value as depicted in Figure 3 is given in the following expression:

$$F = \int_{t_1}^{t_2} L dt \quad (6)$$

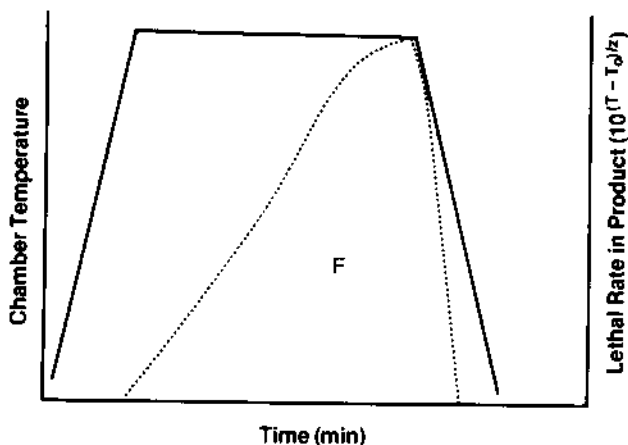
where  $L = 10^{(T-T_0)/Z}$ , which is the lethality constant integrated over time limits between time 1 and time 2. Integrating Eq. (6) between two time points will yield the area under the  $10^{(T-T_0)/Z}$  versus time curve, as seen in Figure 3.

The more familiar  $F_0$  equation is specific for a  $Z$  value of  $10^\circ\text{C}$  and a  $T_0$  value of  $121^\circ\text{C}$ .

$$F_0 = \Delta t \sum 10^{(T-121)/10} \quad (7)$$

An example of a manual calculation of  $F_0$  value is presented in Table 1.





**Figure 3** Plot showing the difference between chamber temperature versus time (—) and lethal rate in the product versus time (·····).  $F$  is the area under the dotted-line curve.

The  $F_0$  value is mentioned both in the USP and in the Current Good Manufacturing Practices (CGMPs) for large volume parenterals (LVPs). Both sources indicate that the steam sterilization process must be sufficient to produce an  $F_0$  value of at least 8 min. This means that the coolest location in the sterilizer loading configuration must be exposed to an equivalent time of at least 8 min of exposure to a temperature of at least 121°C. Unless the  $D$  value is known, however, the number of log reductions in the microbial indicator population will not be known. This is why knowledge of the  $D$  value is of extreme importance in determining the log reduction in the microbial bioburden.

The equation used for determining the microbial log reduction value is derived as follows:

$$D_t = \frac{t}{\log A - \log B} \quad (8)$$

where  $t$  is the heating time at a specific temperature,  $A$  the initial number of micro-organisms (bioburden or microbial load), and  $B$  the number of surviving micro-organisms after heating time  $t$ . By defining  $t$  in Eq. (8) as the equivalent time exposure to a given temperature  $T$ , Eq. (8) then may be expressed as

$$D_T = \frac{F_T}{\log A - \log B} \quad (9)$$

When Eq. (9) is rearranged to solve for the microbial reduction value

**Table 1** A Manual Calculation of  $F_0$  Value

Sterilization time (min)	Product temperature ( $^{\circ}\text{C}$ )	$10^{(T-121)/10}$
5	100	0.008
6	103	0.016
7	106	0.032
8	109	0.063
9	112	0.126
10	115	0.251
11	118	0.501
12	121	1.000
13	121	1.000
14	121	1.000
15	118	0.501
16	115	0.251
17	112	0.126
18	109	0.063
19	106	0.032
20	103	0.016
21	100	0.008
		$F_0 = 5.000 \text{ min}^a$

<sup>a</sup> $F_0 = \Delta t (\Sigma \text{ of lethal rates}) = 1 \times 4.994 = 5.0 \text{ min}$ ;  $\Delta t$  is the time interval between successive temperature measurements.

$$\log A - \log B = Y_n = \frac{F_T}{D_T} \quad (10)$$

As an example, if  $F_T = 8 \text{ min}$  and  $D_T = 1 \text{ min}$ , the microbial reduction value  $Y_n = 8$ , or the process has been sufficient to produce 8 log reductions in the microbial population having a  $D$  value of 1 min at the specified temperature  $T$ .

### C. Probability of Nonsterility

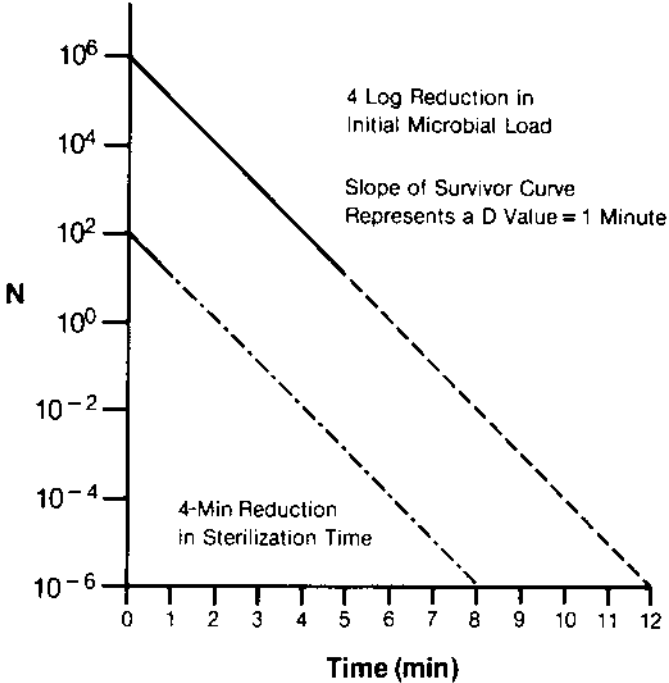
Pflug [14] suggested that the term *probability of a nonsterile unit* be adopted to define products free of microbial contamination. This term mathematically is  $B$  in Eq. (10). Thus, solving for  $B$

$$B = \text{antilog} \left( \log A - \frac{F_T}{D_T} \right) \quad (11)$$

The expression  $10^{-6}$ , commonly used in sterilization validation, is the  $B$  term in Eq. (11). What this means is that after an equivalent time-exposure period of  $F_T$  units, the microbial population having an initial value of  $A$  has been reduced to a final  $B$  value of  $10^{-6}$ . Statistically, this exponential term signifies that one out of 1 million units of product theoretically is nonsterile after sterilization exposure of  $F_T$  units. For example, if  $10^6$  micro-organisms having a  $D$  value of 1 min at  $121^\circ\text{C}$  are placed in a container and the container exposed to  $121^\circ\text{C}$  for an equivalent time of 12 min

$$B = \text{antilog} \left( \log 10^6 - \frac{12 \text{ min}}{1 \text{ min}} \right) = 10^{-6} \tag{12}$$

Probability of nonsterility may be extrapolated from the  $D$  value slope when plotting the log of the microbial population versus time (equivalent time at a specific temperature), as shown in Figure 4.



**Figure 4** Survivor curves showing the effect of decreasing the microbial load ( $A$ ) from  $10^6$  to  $10^2$  on the time required to achieve a probability of nonsterility ( $B$ ) of  $10^{-6}$ .

Manipulation of the  $A$ ,  $F_T$ , and  $D_T$  values in Eq. (11) will naturally produce different values of  $B$ . Accordingly, if it is desirable that  $B$  be as low as possible, this may be accomplished in one of three ways: (1) reducing the bioburden  $A$  of the bulk product, (2) increasing the equivalent exposure time  $F_T$ , or (3) employing a micro-organism with a lower  $D$  value at the specified temperature. Since option 3 most likely is impossible, as the most resistant micro-organisms of a fixed  $D$  value must be used in sterilizer validation, one must either employ techniques to assure the lowest possible measurable microbial bioburden prior to sterilization or simply increase the sterilization cycle time.

### **III. BASIC PRINCIPLES IN THE VALIDATION OF STERILE PRODUCTS**

The key to successful validation in sterile product processing, as in any of type of process validation, is being systematic in the theoretical approaches to validation, the performance of the actual validation experiments, and the analysis and documentation of the validation data.

#### **A. Theoretical Approaches**

Generally, five basic steps are necessary to validate any manufacturing process [15].

1. Written documentation
2. Manufacturing parameters
3. Testing parameters
4. In-process controls
5. Final product testing

In sterile product manufacturing, five major steps are involved in approaching the validation of a sterile process. These are outlined below using thermal sterilization as the example process.

1. Select or define the desired attributes of the product. Example: The product will be sterile.
2. Determine specifications for the desired attributes. Example: The product will be sterilized by a sterilization process sufficient to produce a probability of nonsterility of one out of 1 million containers ( $10^{-6}$ ).
3. Select the appropriate processes and equipment. Example: Use microbial kinetic equations such as Eq. (11) to determine the probability of nonsterility. Select cleaning equipment and container component

procedures designed and validated to reduce the product bioburden to the lowest practical level. Select an autoclave that can be validated in terms of correct operation of all mechanical controls. Use the appropriate types of thermocouples, thermal sensing devices, biological indicators, integrated chemical indicators, and culture media to conduct the validation tests.

4. Develop and conduct tests that evaluate and monitor the processes, equipment, and personnel.

Examples:

- a. Determine microbial load counts prior to container filling.
  - b. Determine  $D$  and  $Z$  values of biological indicator organism.
  - c. Perform heat distribution studies of empty and loaded autoclave.
  - d. Perform heat penetration studies of product at various locations in the batch.
5. Examine the test procedures themselves to ensure their accuracy and reliability.

Examples:

- a. Accuracy of thermocouples as a function of variances in time and temperature.
- b. Repeatability of the autoclave cycle in terms of temperature and  $F$  value consistency.
- c. A challenge of the sterilization cycle with varying levels of bioindicator organisms.
- d. Reliability of cleaning processes to produce consistent low-level product bioburdens.

Each validation process should have a documented protocol of the steps to follow and the data to collect during the experimentation. As an example, App. I presents a protocol for the validation of a steam sterilization process.

Upon completion of the experimental phase of validation, the data are compiled and evaluated by qualified scientific personnel. The results may be summarized on a summary sheet, an example of which is shown in [Table 2](#). Once a process has been validated, it must be controlled to assure that the process consistently produces a product within the specifications established by the validation studies. As shown in [Table 2](#), documentation should present original validation records, a schedule of revalidation dates, and data from the revalidation studies. The interval between validation studies strictly depends on the judgment of the validation team based on the experience and history of the consistency of the process.

[Table 3](#) lists the sterilization methods used for sterile products. There are five basic methods—heat, gas, radiation, light, and filtration. The first four methods destroy microbial life, while filtration removes micro-organisms. Vali-

**Table 2** Steam Sterilization Process Summary Sheet

---

Autoclave identification number or letter: P6037  
Location: building 22, floor 1  
Tag No.: 896101  
Validation date: 10-14-99  
Revalidation date: 4-14-00  
Description of process validated: load containing filling equipment and accessories not to exceed 102 kg  
Temperature set point for validation: 121.0°C  
Temperature range for validation:  $\pm 0.5^\circ\text{C}$   
Cycle validated: 35 min  
Validation records stored in archives: A105-11  
Revalidation records stored in archives: C314-70

---

dation approaches and procedures used for most of these methods will be addressed in the remainder of this chapter. Gaseous validation and radiation validation approaches will be focused on ethylene oxide and gamma radiation, respectively. The other gaseous and radiation methods, however, generally will follow the same principles as those discussed for ethylene oxide and gamma

**Table 3** Methods of Sterilization of Sterile Products

---

Heat

1. Moist heat (steam) = saturated steam under pressure = autoclave
2. Dry heat = oven or tunnel

Gas

1. Ethylene oxide
2. Peracetic acid
3. Vapor phase hydrogen peroxide
4. Chlorine dioxide

Radiation

1. Gamma
2. Beta
3. Ultraviolet
4. Microwave

Light

1. PureBright

Filtration

---

radiation. Some extra coverage will be given to vapor phase hydrogen peroxide because of its increased application, particularly in the sterilization of barrier isolators.

## IV. VALIDATION OF STEAM STERILIZATION CYCLES

### A. General Considerations

The literature contains more information on steam sterilization validation than any other process in the sterile product area. One reason was the publication of the proposed CGMPs for LVPs in June 1976. Actually, the FDA had been surveying the LVP industry long before the proposed CGMPs for LVP regulations were published. One of the major areas of concern was sterility and the heat sterilization processes for achieving sterility. Thus, at least three sections of the proposed CGMPs for LVPs contain statements related to steam sterilization validation. Although these regulations have not become officially and legally valid, they are taken seriously by the parenteral industry. Table 4 summarizes CGMP-LVP statements pertaining to steam sterilization validation.

The key expression used in steam sterilization validation is  $F_0$ . Interestingly, despite the familiarity of this term, it is still misunderstood or misused in the parenteral industry. The main purpose of the  $F_0$  value is to express in a single quantitative term the *equivalent time* at which a microbial population having a  $Z$  value of  $10^\circ\text{C}$  has resided at a temperature of  $121.1^\circ\text{C}$ . The time units here are not clock time units; rather,  $F_0$  time is a complete summary of the time the indicator organism spent during the entire cycle at a temperature of exactly  $121.1^\circ\text{C}$  plus a fraction of the times spent at temperatures below  $121.1^\circ\text{C}$ , in addition to a multiple of the times spent at temperatures greater than  $121.1^\circ\text{C}$ .  $F_0$  is a summation term, as exemplified in Figure 3 and Table 1.  $F_0$  is a time value that is referenced to  $121.1^\circ\text{C}$ . It includes heat effects on microorganisms during the heating and cooling phases of the cycle, taking into account that heat effects below  $121.1^\circ\text{C}$  are not as powerful in destroying microbial life as the effect found at  $121.1^\circ\text{C}$ .

$F_0$  values may be calculated in several ways. The basic way is by manually recording the temperature of the monitored product at specific time intervals, substituting the recorded temperature for  $T$  in Eq. (7), solving the exponential part of the equation for all temperatures recorded, and then multiplying by  $\Delta t$ . This was done in Table 1. Alternatively, and more expediently, a computer program can integrate the temperature and time data to obtain the  $F_0$  value. This approach is now widely used because of the availability of programmable multipoint recorders that record temperature and solve the  $F_0$  equation on an accumulative basis.

**Table 4** Statements Concerning Sterilization Cycle Design and Validation in the Proposed Good Manufacturing Procedures for LVPs

---

*Section 212.240*

Procedure for steam sterilization must be sufficient to deliver an  $F_0$  of 8 or more

*Section 212.243*

Testing of the sterilization processes requires:

1. A maximum microbial count and a maximum microbial heat resistance for filled containers prior to sterilization.
2. Heat distribution studies for each sterilizer, each loading configuration, every container size, using a minimum of 10 thermocouples.
3. Heat penetration studies using product of similar viscosity as that packaged in container studied. Locate slowest heating point in the container. Use 10 or more containers, each with a suitable biological indicator and submerged thermocouple.  $F_0$  value is determined beginning when the sterilizer environment has established itself as shown by reproducible heat distribution studies and specific sterilizer temperature has been achieved, and ending when cooling has been initiated.

*Section 212.244*

Statements on sterilization process design

1. Procedures required to establish uniform heat distribution in the sterilizer vessel. Temperatures must be held at  $\pm 0.5^\circ\text{C}$  from the time the product achieves process temperature until the heating portion completed.
  2. Verify uniformity of heat distribution for each loading pattern.
  3. Temperature of the product and the sterilizer must not fall below the minimum that has been established for the prescribed sterilization process.
  4. Establish the time requirement for venting the sterilizer of air.
  5. Establish the product come-up time to the desired temperature.
  6. Establish the cooling time.
- 

$F_0$  values may be solved using the biological approach [i.e., Eq. (9)]. The approach is used when  $D_{121}$  and  $A$  are accurately known and a desired level of survivor probability ( $B$ ) is sought. In this case, Eq. (9) is rearranged as

$$F_0 = D_{121}(\log A - \log B)$$

For example, if  $D_{121} = 1.0$  min,  $A = 10^6$ , and  $B = 10^{-6}$ ,  $F_0$  is calculated to be

$$F_0 = 1(\log 10^6 - \log 10^{-6}) = 12 \text{ min}$$

Thus, the cycle must be adjusted so that the  $F_0$  value calculated by physical methods (time and temperature data) will be at least 12 min.



An approach for solving  $F_0$  values involves the use of a chemical indicator, called Thermalog S,\* which is calibrated in terms of  $F_0$  units. The device was described by Witonsky [16] and evaluated by Bunn and Sykes [17]. Thermalog strips are placed in the containers being steam sterilized. Each strip contains a chemical sensor that responds to increasing saturation steam temperature. The millimeter distance advanced by the chemical sensor is linearly related to the  $F_0$  value ( $T_0 = 121^\circ\text{C}$ ,  $Z = 10^\circ\text{C}$ ). The advantages of using this device lie in its replacing biological indicators in the validation and monitoring of steam sterilization cycles and its ability to assess  $F_0$  in any part of the sterilizer load, however inaccessible to conventional thermocouple monitoring devices. The main disadvantage is the paucity of available data proving the sensitivity and reliability of the chemical indicator system.

With the main emphasis being the validation of a steam sterilization cycle based on the achievement of a certain reproducible  $F_0$  value at the coolest part of the full batch load, procedures for validation of a steam sterilization process will now be discussed.

## **B. Qualification and Calibration**

### **1. Mechanically Checking, Upgrading, and Qualifying the Sterilizer Unit**

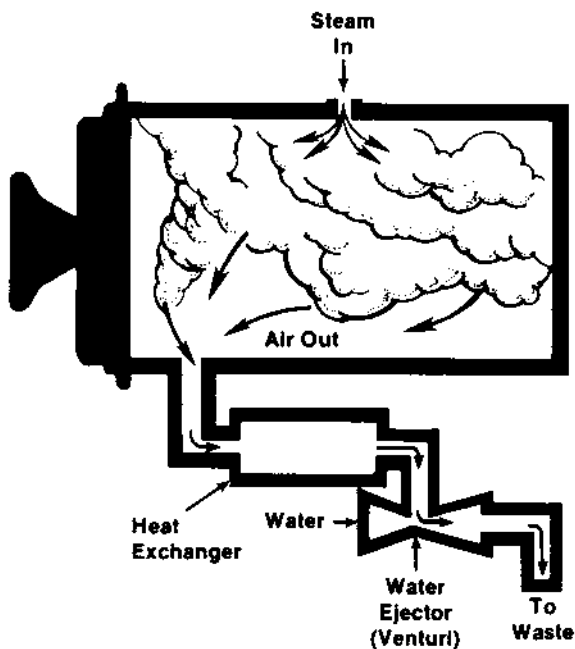
The functional parts of an autoclave are shown in [Figure 5](#). The main concern with steam sterilization is the complete removal of air from the chamber and replacement with saturated steam. Older autoclaves relied on gravity displacement. Modern autoclaves use cycles of vacuum and steam pulses to increase the efficiency of air removal. Autoclaves can also involve air–steam mixtures for sterilizing flexible packaging systems and syringes. Whatever autoclave system is used, the unit must be installed properly and all operations qualified through installation qualification and operation qualification (IQ/OQ). Utilities servicing the autoclave must be checked for quality, dependability, proper installation, and lack of contamination. The major utility of concern here is steam. All equipment used in studying the steam sterilizer, such as temperature and pressure instrumentation, must be calibrated.

### **2. Selection and Calibration of Thermocouples**

Thermocouples obviously must be sufficiently durable for repeated use as temperature indicators in steam sterilization validation and monitoring. Copper-constantan wires coated with Teflon are a popular choice as thermocouple monitors, although several other types are available.

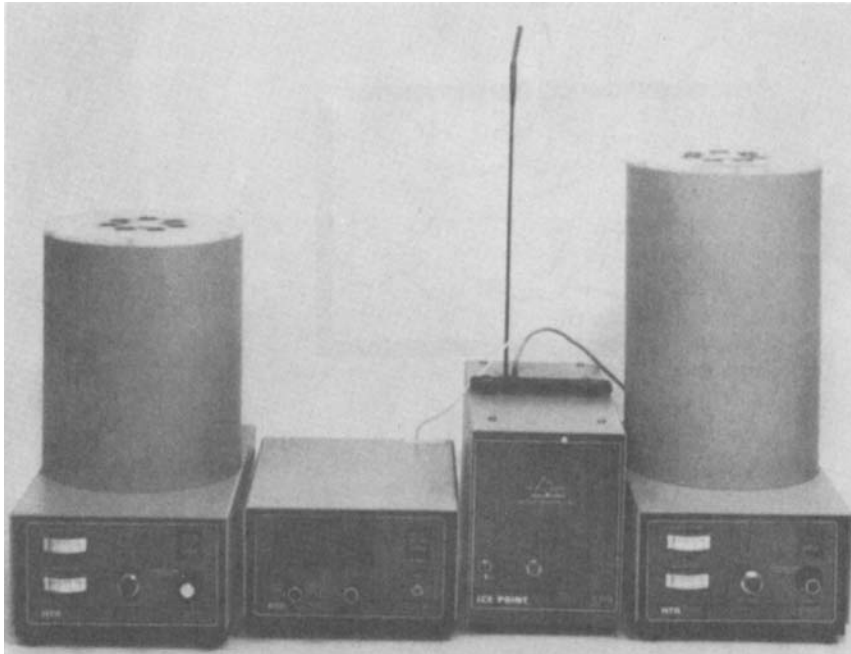
---

\*Bio Medical Sciences, Fairfield, NJ.



**Figure 5** The functional parts of a modern autoclave. (Courtesy of American Sterilizer Company, Erie, Pennsylvania.)

Accuracy of thermocouples should be  $\pm 0.5^{\circ}\text{C}$ . Temperature accuracy is especially important in steam sterilization validation because an error of just  $0.1^{\circ}\text{C}$  in temperature measured by a faulty thermocouple will produce a 2.3% error in the calculated  $F_0$  value. Thermocouple accuracy is determined using National Bureau of Standards (NBS) traceable constant temperature calibration instruments such as those shown in [Figure 6](#). Thermocouples should be calibrated before and after a validation experiment at two temperatures:  $0^{\circ}\text{C}$  and  $125^{\circ}\text{C}$ . The newer temperature-recording devices are capable of automatically correcting temperature or slight errors in the thermocouple calibration. Any thermocouple that senses a temperature of more than  $0.5^{\circ}\text{C}$  away from the calibration temperature bath should be discarded. Stricter limits (i.e.,  $<0.5^{\circ}\text{C}$ ) may be imposed according to the user's experience and expectations. Temperature recorders should be capable of printing temperature data in  $0.1^{\circ}\text{C}$  increments.



**Figure 6** Modern equipment employed in the calibration of thermocouples used in sterilizer validation studies. (Courtesy of Kaye Instruments, Inc., 15 De Angelo Drive, Bedford, Massachusetts.)

### 3. Selection and Calibration of BI

The organism most resistant to steam heat is the bacterial spore former *B. stearothermophilus*. Other indicator organisms have been employed, but *B. stearothermophilus* spores are by far the most commonly used BIs in validating steam sterilization cycles.

Since the main purpose of BIs is to assure that a minimum  $F_0$  value has been achieved in the coolest location of the autoclave load, the  $D_{121}$  and  $Z$  values of the BI must be accurately known. Whether BIs have been prepared by the manufacturer or purchased commercially, laboratory  $D$  values must be calculated [18].

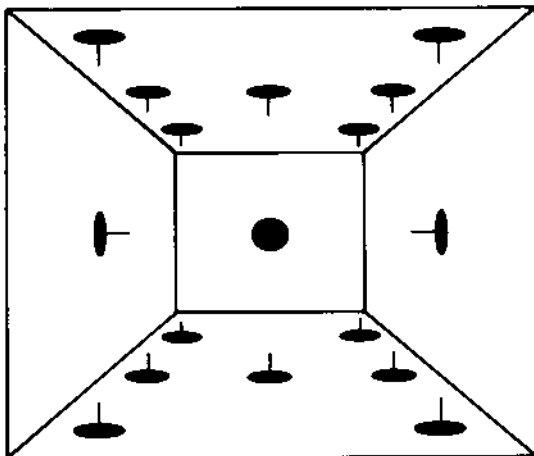
Spore strips or spore suspensions are used in the validation studies. The number of micro-organisms per strip or per ml of suspension must be as accurately known as the  $D$  value.

Precautions should be taken to use proper storage conditions for *B. stearothermophilus* BIs. Storing in the freezer provides a more stable resistance profile for the shelf life of the indicator [19].

If one knows the  $D$  value, the BI concentration or population  $A$  and the desired probability level of nonsterility  $B$ , the minimum  $F_0$  value that must be achieved by the sterilization cycle for the particular load can be calculated. For example, if  $A = 10^6$  and  $B = 10^{-6}$  and laboratory studies determine the  $D$  value for *B. stearothermophilus* in the product to be sterilized to be 0.4 min ( $F_0 = 0.4(12) = 4.8$  min), a minimum  $F_0$  value of 4.8 min should be achieved at the worst case location during heat-penetration studies. The USP requires a steam sterilization process to deliver a lethality input of 12D for a typical “overkill” approach.

### C. Heat-Distribution Studies

Heat-distribution studies include two phases: (1) heat distribution in an empty autoclave chamber and (2) heat distribution in a loaded autoclave chamber. Between 10 and 20 thermocouples should be used per cycle. Thermocouples should be secured inside the chamber according to a definite arrangement (e.g., see Fig. 7); Teflon tape can be used to secure thermocouples. The trips where



**Figure 7** Suggested locations for thermocouples on a single shelf for heat-distribution studies in heat sterilizers.

the wires are soldered should not make contact with the autoclave interior walls or any metal surface. One thermocouple each should remain in an ice bath and high-temperature oil bath during each cycle for reference when the temperature-monitoring equipment has the capability for electronically compensating each temperature measurement against an internal reference. Heat-distribution studies following the initial study may employ fewer thermocouples as the cool spot in the chamber and in the load is identified. The key is to identify on a reproducible basis the location of the cool spot and the effect of the load size and/or configuration on the cool spot location. Most experts suggest the study of the minimum and maximum load size in the proper configuration in elucidating where the cool spot is located.

The difference in temperature between the coolest spot and the mean chamber temperature should be not greater than  $\pm 2.5^{\circ}\text{C}$  [7].\* Greater temperature differences may be indicative of equipment malfunction.

#### **D. Heat-Penetration Studies**

This is the most critical component of the entire validation process. The success of a validated cycle depends on determining the  $F_0$  value of the cold spot inside the commodity located at the cool spot previously determined from heat-distribution studies. The container cold spot for containers  $\geq 100$  ml is determined using container-mapping studies. Thermocouple probes are inserted within a container and repeat cycles are run to establish the point inside the container that is coldest most of the time. It is this exact point that is monitored during heat-penetration studies.

Again, the minimum and maximum loading configurations should be studied. Thermocouples will be placed both inside and outside the container at the cool spot location(s), in the steam exhaust line, and in constant-temperature baths outside the chamber. The  $F_0$  value will be calculated based on the temperature recorded by the thermocouple inside the container at the coolest area of the load. Upon completion of the cycle, the  $F_0$  value will indicate whether the cycle is adequate or if alterations must be made. Following the attainment of the desired time-temperature cycle, cycles are repeated until the user is satisfied with the repeatability aspects of the cycle validation process. Statistical analysis of the  $F_0$  values achieved at each repeated cycle may be conducted to verify the consistency of the process and the confidence limits for achieving the desired  $F_0$  value.

There are three critical times associated with all wet heat sterilization processes (20).

---

\*In fact, a difference  $\geq 1.0^{\circ}\text{C}$  gives rise to the suspicion of air-stream mixtures in the chamber.

1. A minimum  $F$  value
2. A design  $F$  value
3. A sterilization process time

The minimum  $F$  value is based only on microbial spore destruction. It is believed that  $F_0 = 12$  min is a realistic minimum value, since most mesophilic spore-forming micro-organisms have  $D$  values  $\leq 0.5$  min at  $121^\circ\text{C}$ . Even if  $D_{121} = 1.0$  min, the spore log reduction value according to Eq. (10) would be  $12^*$ .

The  $F$  value used in the design of a sterile cycle may greatly exceed the minimum  $F_0$  of 12. An  $F_0 = 18$  min will provide a 50% safety factor that will take into account additional time that may be required for steam to penetrate certain containers in middle or cool locations of the autoclave.

The sterilization process time is determined from the design  $F$  value and the product heat transfer data. The sterilization cycle design must be based on the heating characteristics of the load and of containers located in the slowest heating zone of the load. The variation in the rate of heating of the slowest heating zone must be known, so this variation must be determined under fully loaded conditions. The effect of load-to-load variation on the time-temperature profile must also be determined. Then, the statistically worst-case conditions should be used in the final sterilization process design.

The final step in steam sterilization validation is the establishment of a monitoring program to ensure that the validated cycle remains essentially unchanged in the future. Cycle monitoring usually involves the use of thermocouples to measure heat penetration at the cool spot location and to verify that the design  $F_0$  value has been reached.

Any changes in the load size, load configuration, or container characteristics (volume, geometry, etc.) must be accompanied by repeat validation studies to prove that the cool spot location has not changed or, if it has, that it receives the design  $F_0$  time exposure from the sterilization cycle used.

## V. VALIDATION OF DRY-HEAT STERILIZATION CYCLES

### A. General Considerations

Two types of dry-heat sterilization systems are utilized in the pharmaceutical industry today. They are the conventional hot air oven and the tunnel system. The major difference between the two systems, as far as validation is concerned, is the belt or line speed variable with the tunnel system.

The key to validating a dry-heat sterilizer is to prove its repeatability. This

---

\*A current trend for overkill sterilization validation is to establish the minimum  $F_0$  value that will result in the inactivation of  $10^6$  *B. stearothermophilus* spores then double the dwell time for this  $F_0$  value to provide assurance of overkill.

means that the unit can consistently perform under a given set of conditions to generate materials that are sterile, pyrogen-free, and particulate-free. Repeatability in dry-heat sterilization obviously involves consistency and reliability in attaining and maintaining a desired temperature. The desired temperature must be reached in all areas of the heating chamber. There will always be an area in the chamber that represents a cold spot; that is, an area that is most difficult to heat up to the desired temperature. This cold spot must be identified so that validation studies involving thermocouple monitoring and microbial challenges can be done at this location. If certain key GMP features of the dry-heat sterilizer are not controlled, with time the cold spot within the sterilizer will change and the key element of validation repeatability cannot be achieved. Simmons [21,22] discussed the GMP features of both the batch oven and tunnel sterilizer that must be controlled *before* doing any validation studies. These are listed in Tables 5 and 6. Without control of these processes features, as Simmons has clearly stated, validating or even qualifying a dry-heat sterilizer is a total waste of time and money.

As with any sterilization process, the first step in dry-heat sterilizer validation involves qualification of all the equipment and instrumentation used. This step includes examination and documentation of all utilities, ductwork, filters, and control valves or switches for the oven or tunnel unit, and the calibration of the instrumentation used in validating and monitoring the process. The instruments used are as follows:

1. Temperature recorders and thermocouples
2. Constant-temperature baths
3. Amp meters
4. Monometers
5. Dioctylphthalate generators
6. Particle counters
7. Velometers
8. Tachometers

**Table 5** Key Process Features to Control Prior to Validating Dry-Heat Sterilizers

Batch (oven)	Tunnel sterilizer
Intake air system	Positive pressure to entrance
Exhaust air system	Even distribution of heat
Internal air circulation	Belt speed recorder
Exhaust HEPA filter	HEPA-filtered cooling air
Static pressure gauge	Exhaust HEPA filter
Heater current	Heater current
	Particulate control

**Table 6** Basic Equipment Performances That Must Be Verified Prior to Calibration-Validation Studies

Function	Dry heat process			
	Convection batch	Convection continuous	Conduction batch	Radiant continuous
Electrical logic	×	×	×	×
Cycle set point adjustment	×	×	×	×
Vibration analysis	×	×	×	×
Blower rotation	×	×	×	×
Blower rpm	×	×	×	×
Heater elements	×	×	×	×
Air balance	×	×	×	×
Air balance ability	×	×	×	×
Door interlocks	×			
Commodity interlocks		×		
Gasket integrity	×	×		
HEPA filter integrity	×	×		×
Belt speed		×		×
Heat shields			×	×

Calibration should be conducted on a regular interval basis. Simmons [22] recommends a regular calibration interval of every 3 months.

Validation studies conducted on dry-heat sterilizers can be divided into two basic components. One component envelops all the physical elements that must be qualified, such as temperature control, air particulate levels, and belt speeds. The other component is the biological constituent, which involves studies that prove that the process destroys both microbial and pyrogenic contaminants.

## B. Batch Oven Validation

1. Air balance determination. In an empty oven, data are obtained on the flow rates of both intake and exhaust air. Air should be balanced so that (a) positive pressure is exerted to the nonsterile side when the door is opened and (b) air velocity across and up and down the opening of the door is  $\pm 50$  feet per minute (FPM) of the average velocity (measured 6 in. from the side wall on the air supply wall).
2. Heat distribution of an empty chamber. Thermocouples should be situated according to a specific predetermined pattern. Repeatability of temperature attainment and identification of the cold spot can be



achieved if the temperature range is  $\pm 15^{\circ}\text{C}$  at all monitored locations. Heat-distribution studies can also be conducted as a function of variable air flow rates through the hood ducts and as a function of the gas flow rate to the sterilizing burners. A suggested thermocouple placement pattern per shelf in an empty oven is presented in [Figure 7](#).

3. Heat-penetration studies. These studies should be designed to determine the location of the slowest heating point *within* a commodity at various locations of a test load in the sterilizer. The test load should be the maximum size of load anticipated. Thermocouples are placed in the commodities located in the areas likely to present the greatest resistance to reaching the desired temperature. Minimum and maximum temperatures as defined in the process specifications should be studied. Normally, three replicate cycles are run at each temperature. The cold spot must not move during the replicate studies. Firm identification of the most difficult location for heat to penetrate will represent the area to be used for the biological challenge studies. Other variations in the cycle affecting heat penetration at the cold spot can be studied, and these might include (a) test load variations, (b) temperature set point variations, and (c) variations in the time of exposure.
4. Mechanical repeatability. During all these studies, mechanical repeatability in terms of air velocity, temperature consistency, and reliability and sensitivity of all the oven and instrumental controls must be verified.

### **C. Tunnel Sterilizer Validation**

Principles as described above for the physical process validation of batch ovens apply also in the validation of tunnel sterilizers; however, in addition to the variables affecting batch oven validation, tunnel sterilizers have an extra variable-belt speed. This variable can be held constant by maintaining the same belt speed throughout the validation process and not changing it after validation has been completed.

#### **1. Air Balance Determination**

Proper and even air balance is more critical to a tunnel sterile process than a batch oven process. Since the items being sterilized are moving, they are exposed to different air systems (e.g., heating zone and cooling zone). Air flow must be balanced in order to provide a gradual decrease in air temperature as items move along the conveyor. In the absence of a critical balance of air dynamics, either the items will not be cooled sufficiently once they exit the tunnel or they will be cooled too quickly, causing the glass to shatter and contaminate the entire tunnel area with particles. In fact, the major problem in validating

tunnel sterilizers is the control of particles. Not only are the items exposed to great extremes in temperature, but also the conveyor belt is a natural source of particulates because metal is moving against metal.

Adjustments in the air source should be made to obtain a controlled flow of air within the tunnel and across the entrance and exit openings. Air must be particulate-free as it enters the tunnel area; therefore, all high efficiency particulate air (HEPA) filters in the tunnel must be integrity tested and certified prior to validation studies.

## 2. Heat-Distribution Studies

Thermocouples used in tunnel sterilizer validation must be sufficiently durable to withstand the extremely high ( $\geq 300^{\circ}\text{C}$ ) temperatures in the heating zone area of the tunnel. Heat-distribution studies should determine where the cold spots are located as a function of the width of the belt and height of the tunnel chamber. Trays or racks of ampules or vials should be run through the tunnel and thermocouples placed at strategic locations among the containers.

Bottle-mapping studies may also be conducted during this phase [21]. The purpose of these studies is to determine possible locations inside the container that are most difficult to heat. The loading configuration should be identical to what will be used in production cycles. The major difficulty in doing these studies is the avoidance of thermocouple wire hang-ups. Thermocouples must be long enough to be transported through the entire tunnel. A special harness for thermocouple wires should be constructed for feeding these wires into and throughout the tunnel.

Repeatability of the thermal process must be demonstrated during these studies. Peak temperature readings should remain within  $\pm 10^{\circ}\text{C}$  across the belt for at least three replicate runs.

## 3. Heat-Penetration Studies

Prior to microbial challenge testing of the tunnel sterilization, heat-penetration studies must be completed in order to identify the coolest container in the entire load. Results of heat-distribution studies should aid in predicting where the coolest location within the load should be. Thermocouples should be deposited at or near the coolest point inside the container as determined previously from bottle-mapping studies. Normally, the coolest point inside the container is at the juncture of the bottom of the container and the sidewall. The container's inner surface should be in contact with the thermocouple tip because the objective is to sterilize the inner walls of the container, as well as the inner space.

Three to five replicate runs for each commodity size and every loading configuration should be done using 10 to 20 thermocouples distributed throughout the load. Careful analysis of the temperature data after each run will be

invaluable in the determination of the cool spot and the repeatability of the process using the minimum number of replicate runs.

#### 4. Mechanical Repeatability

Tunnel sterilizers must demonstrate mechanical repeatability in the same manner as batch ovens. Air velocity, air particulates, temperature consistency, and reliability of all the tunnel controls (heat zone temperatures, belt speed, and blower functions) must be proved during the physical validation studies.

#### **D. Biological Process Validation of Dry-Heat Sterilization Cycles**

If a dry-heat process is claimed to produce sterile commodities, micro-organisms known to be most resistant to dry heat must be used to prove the ability of the dry-heat cycle to destroy them at the coolest location in the load. If the dry-heat process is claimed to produce both sterile and pyrogen-free commodities, validation studies must be done using both micro-organisms and microbial endotoxins. It is the strong opinion of many, including the authors, that biological validation of dry-heat cycles should be based on the destruction of endotoxin rather than on the destruction of microorganisms because of the enormous dry-heat resistance of endotoxin compared to micro-organisms [23]. To satisfy the FDA, however, microbial challenges continue to be done.

With both micro-organism and endotoxin challenges, the cool spot identified in the heat-distribution and heat-penetration studies will be the logical location to run the microbial challenge tests. Containers inoculated with microbial cells or endotoxin will be situated adjacent to identical containers into which thermocouples are secured to monitor temperature. Temperature profiles must not deviate from temperature data obtained in earlier studies.

The goal of the biological validation procedure depends on the nature of the process. If the process is intended to sterilize only, the probability of survival approach is used. In this case, validation studies must determine a dry-heat cycle that will assure that the probability of survival of the microbial indicator is not greater than  $10^{-6}$ . If the process is intended to sterilize and depyrogenate, which occurs when the materials can withstand excessive heat, the overkill approach is used. The goal here is to validate a heating cycle that can produce a 12-log reduction in the biological indicator population.

Equations that apply for determining log reductions or survival probabilities are Eq. (11) and Eq. (12), respectively. Information that must be known prior to initiating biological validations include the  $D$  value of the biological indicator to be used, the change in its heat resistance as temperature is changed ( $Z$  value), and the presterilization microbial load on the commodity being steri-

lized. Methods for obtaining these values have been adequately described with ample references in the Parenteral Drug Association technical report on dry-heat validation [13].

The most widely used biological indicators for dry heat have been spores of *B. subtilis*; however, spores of other bacterial species may be used if they are shown to have greater resistance to dry heat. At 170°C, even the most resistant microbial spore form will have a *D* value of 6 to 10 min. At temperatures required to depyrogenate, microbial spores will have *D* values of only a few seconds.

The acceptable *Z* value for microbial dry-heat resistance is 20°C [13]. This value is used primarily in programming computerized temperature-detection devices, which take temperature data from thermocouple monitors and compute *F* values as seen with Eq. (6). A suggested *Z* value to be used for endotoxin dry-heat resistance is 54°C [24]. The greater *Z* value for endotoxin demonstrates the greater resistance of endotoxin to dry heat.

A suggested step-by-step sequence in the microbial validation of a dry-heat process for sterilizing and depyrogenating large-volume glass containers by a convection batch oven is presented. Procedures for the validation of a tunnel sterilization process have been reported by Wegel [25] and Akers et al. [26].

1. The overkill approach is selected for the validation study. This eliminates the need for bioburden and resistance studies. The objective is to ensure that the coolest area in the loading pattern, as determined in earlier heat-penetration and heat-distribution studies, receives sufficient heat to cause a 12-log reduction in the biological indicator chosen.
2. Select the type of biological indicator to be used in monitoring process lethality. Calibrate the biological indicator in its carrier medium (strip or suspension).
3. Place spore carrier in approximately 12 glass bottles located at the previously determined coolest area of the oven. Bottles adjacent to the inoculated bottles should contain thermocouples for monitoring purposes.
4. Run a complete cycle using the desired loading pattern for future dry-heat overkill cycles.
5. After the cycle, aseptically transfer the spore strip to vessels of culture media. If spore suspensions were used, aseptically transfer the inoculated bottles to a laminar airflow workstation and add culture media to the bottles. Use appropriate positive and negative controls.
6. Determine the number of survivors by plate-counting or fraction negative methods [13].
7. Use Eq. (10) to determine the number of spore log reductions (SLRs):

$$\text{SLR} = \frac{F_{170}}{D_{170}}$$

As described in the PDA Technical Report no. 3 [13, p. 48], the overkill approach usually yields extremely high  $F$  values. A minimum  $F$  value can be estimated by assuming one positive unit. In this case, if 12 challenge bottles were used and if it is assumed that  $D_{170} = 1.5$  min,  $Z = 20^\circ\text{C}$ ,  $A = 1 \times 10^8$ , and  $B = 12/11$  then

$$F = D_{170}(\log A - 2.303 \log B)$$

$$F = 1.5(8 - 0.087)$$

$$F = 11.87 \text{ min}$$

Therefore, an equivalent time exposure at  $170^\circ\text{C}$  of 11.87 min will produce an SLR value of

$$\text{SLR} = \frac{11.87}{1.5} = 7.9$$

If an SLR of 12 were desirable, the process cycle would be extended to achieve an  $F_{170}$  value of at least

$$F_{170} = 1.5(12) = 18 \text{ min}$$

If a temperature of  $200^\circ\text{C}$  were used and thermocouples located at the coolest area of the load showed that the bottle interior equaled  $200^\circ\text{C}$  or greater for 15 min, the  $F_{170}$  value would be at least

$$F_{170} = 15 \times 10^{[(200-170)/20]} = 474 \text{ min}$$

It is because of these enormous  $F_{170}$  values obtained during overkill cycles that several experts strongly advocate the use of endotoxin challenge studies instead of microbial tests.

## **E. Endotoxin Challenge in the Validation of Dry-Heat Sterilizers**

The most controversial aspect of endotoxin challenge testing is how much endotoxin challenge to use. The PDA [13] suggests using a level of endotoxin in excess of the level expected in the item being subjected to the dry-heat cycle. Simmons [22] suggested the use of 10,000 ng endotoxin. Akers et al. [26] used only 10 ng endotoxin.

Papers by Ludwig et al. (27–30) expanded knowledge of dry heat depyrogenation of glass surfaces using *e. coli* endotoxin challenges.

The step-by-step procedure for the endotoxin validation of a dry-heat process may be as follows:

1. Inoculate commodity samples with a known amount of endotoxin (e.g., 10–100 ng *Escherichia coli* lipopolysaccharide, obtainable from several commercial sources). The endotoxin should be contained in a volume of water equal to the residual water volume following the washing procedure used prior to sterilization.
2. Thermocouples should be placed in commodities adjacent to those containing endotoxin for temperature monitoring and correlation with LAL test results.
3. Endotoxin destruction should be ascertained at the coolest location of the load. Load configurations should be identical to those used in the microbial validation studies.
4. Several endotoxin challenge samples should be done per cycle, and the studies must be adequately replicated (3–5 repeats).
5. Following the dry-heat cycle, aseptically transfer the units containing endotoxin to an aseptic area for extraction procedures, sampling, and conducting the *limulus amoebocyte lysate* (LAL) test.
6. *F* values required for endotoxin destruction at various temperatures and/or cycle time–temperature variations can be determined using a *Z* value of 54°C and the following equation:

$$F_{\text{endo.}} = \Delta t \sum 10^{(T-170)/54}$$

This approach was used by Akers et al. [26].

When the validation studies described in this section have been completed, all data are analyzed and a decision is made concerning their acceptability. If acceptable, the entire validation procedure and all appropriate supporting data are documented in a bound manual. If the studies are unacceptable because of unsubstantiated claims of the process or a lack of reproducibility, further testing must be performed or process variables changed followed by additional validation studies.

The final document will be reviewed and approved by various plant disciplines (engineering, microbiology, production, etc.) before the dry-heat sterilizer is considered fully validated and released for use.

## VI. VALIDATION OF ETHYLENE OXIDE STERILIZATION CYCLES

Ethylene oxide (EtO) has been a sterilant for over 50 years. Yet, while much attention in the literature has been focused on validation of heat sterilization cycles, EtO cycle validation has received relatively little attention. Undoubtedly,

a major reason is the inability to define accurately the kinetics of microbial death upon exposure to EtO. This is a result of the complexity of the process, in which not one but three variables—heat, EtO concentration, and relative humidity—must be controlled in order to determine *D* values of microorganisms when considering EtO sterilization.

The discussion of EtO validation in this section reflects largely what has been written on this subject since 1977. Several good references [31–35] have significantly contributed to the rationale, design, and implementation of validation programs for EtO sterilization cycles.

Five variables are critical to the EtO process. They are EtO concentration, relative humidity, temperature, time, and pressure/vacuum. Temperature is the easiest variable to measure and monitor, therefore temperature is used as the indicator of the worst-case location within the loaded EtO sterilizer. Once the worst-case location is identified, the validation studies are conducted with the goal of inactivating a known concentration of indicator micro-organisms in the worst-case location using a specific loading pattern with a specific EtO cycle with all variables defined and controlled.

The procedure for EtO cycle validation can be described in eight steps.

1. Address the products specifications and package design. What is the chemical nature of the components of the product? Do there exist long and/or narrow lumens that will represent barriers to EtO permeation? How dense are the materials through which EtO gas must permeate? What is the nature of the primary and secondary packaging? Where are dead air spaces within the package and within the load? By addressing questions such as these, the problems in validating the EtO cycle can be anticipated and solved at an early stage in the validation process.
2. Use a laboratory-sized EtO sterilizer during early phases of the validation process as long as the sterilizer is equipped with devices allowing variability in vacuum, relative humidity, temperature, gas pressure, timing, and rate of gassing the chamber. Involve production sterilizer experts in these early phases of the EtO validation process.
3. Verify the calibration of all instrumentation involved in monitoring the EtO cycle. Examples include thermocouple and pressure gauge calibration, gas leak testing equipment, relative humidity sensors, and gas chromatographic instrumentation.
4. Perform an extensive temperature distribution study using an empty sterilizer. Identify the zones of temperature extremes, then use these locations for monitoring during loaded vessel runs. Monitoring will be accomplished using both thermocouples and biological indicator spore strips. The most common biological indicator for EtO cycle

validation is *B. subtilis* var. *niger*. Concentration of these spores per strip usually is  $10^6$ . Significant spore survival results will indicate the need to increase the cycle lethality parameters. It is also prudent to analyze gas concentration at periodic intervals during the distribution studies.

5. Do a series of repetitive runs for each sterilization cycle in an empty vessel in order to verify the accuracy and reliability of the sterilizer controls and monitoring equipment. Thermocouple locations should be basically the same for all the heat-distribution studies.
6. Do a series of repetitive heat-distribution and heat-penetration runs using a loaded EtO sterilizer. The sterilizer should be an industrial unit in order to ascertain the cycle requirements that will yield consistent and reliable assurance that all components of the load will be sterile. The validation procedure should include data collected on both partial- and full-load sizes. The loading design should be defined at this point. Dummy loads closely resembling the actual packaging can be used to test cyclic parameters. Thermocouples and biological indicators should be placed in a statistically designed format throughout the load, including areas within the dummy packaged products. The number of loading patterns, repetitive runs, and the daily timing sequence of events should all be based upon prior knowledge and experience. At this point and before proceeding further, the data should verify the following questions:
  - a. What is the concentration of EtO released into the vessel?
  - b. What is the concentration of water vapor in the vessel?
  - c. What is the range of temperature distribution throughout the loaded vessel?
  - d. How much EtO is consumed during the cycle?
  - e. What are the rates of creating a vacuum and applying pressure?
  - f. What *D* value should be used for the biological indicator employed?
  - g. Does the selected cycle sterilize the product, and what is the estimated probability of nonsterility?
7. Tests should be conducted on the final packaged product. The protocol applied should be one that leads to minimal interruption of the standard manufacturing operations of the facility. Intermediate pilot plant studies should be carried out to simulate large-scale industrial sterilization cycles. The EtO cycle documentation should be integrated into a single protocol. An example of one protocol is as follows:
  - a. Use approximately 10 biological indicators per 100 cubic feet of chamber space.



- b. Place these indicators throughout the load along with thermocouples at the same locations.
  - c. Use at least three sublethal exposure cycle times, each in triplicate; then define the required EtO exposure times using *D* value calculations. The exposure time should be increased by an additional 50% to add a safety factor.
  - d. Perform three or more fully loaded sterilization cycles at the selected exposure time, monitoring these cycles with thermocouples and biological indicators.
  - e. Concomitantly, perform EtO residual tests on the materials exposed to the desired exposure cycle times from full-load runs.
8. Institute a documented monitoring system primarily relying on biological indicators, with lesser reliance on end-product sterility testing.

## VII. VALIDATION OF VAPOR PHASE HYDROGEN PEROXIDE STERILIZATION PROCESS

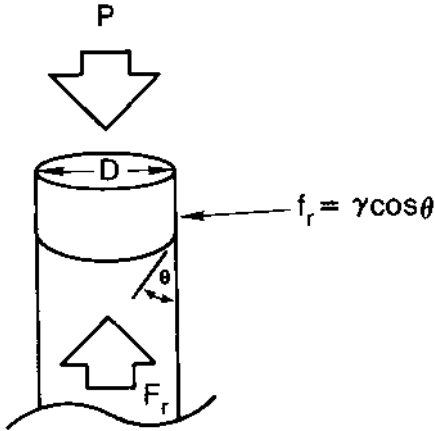
Vapor phase hydrogen peroxide (VPHP) is a relatively new sterilization gaseous agent that is rapidly becoming the gaseous sterilant of choice for many applications, the most well known being the sterilization of barrier isolation systems. Its advantages over other gases, such as ethylene oxide, peracetic acid, chlorine dioxide, and glutaraldehyde, include the following:

1. It does not require temperatures above ambient.
2. There is little or no concern about residual by-products.

Vapor phase hydrogen peroxide equipment and process are described elsewhere [36]. The basic steps in the process are dehumidification, conditioning, sterilization, and aeration. More specifically, there are five steps that must be part of the validation protocol [36].

1. Cycle development
2. Temperature distribution
3. Vapor distribution
4. Biological challenge
5. Aeration verification

Cycle development parameters include temperature, airflow rate, humidity, liquid peroxide concentration, liquid peroxide delivery rate, peroxide vapor delivery temperature, and peroxide vapor half-life. Temperature distribution qualification involves the use of temperature sensors located throughout the sterilant delivery line and throughout the enclosure. Vapor distribution qualification uses



**Figure 8** Capillary filled with a liquid that wets the capillary surface.

chemical indicators to measure VPHP exposure levels. Biological challenges involve placement of biological indicators, normally *Bacillus stearothermophilus* spore strips or stainless steel coupons at many different locations inside the enclosure, particularly in those areas most difficult for vapor to contact and sterilize. Aeration verification determines the parameters (e.g., time, air exchange rates) necessary to reduce VPHP levels within the system to a certain value, usually  $\leq 5$  ppm. Vapor phase hydrogen peroxide sterilization cycles are ultimately validated in the same way as traditional aseptic validation processes via the use of sterile media fills.

### VIII. VALIDATION OF RADIATION STERILIZATION PROCESS

The major objective in validating a radiation sterilization process, regardless of whether the mode of radiation is cobalt-60, cesium-137, or electron beam, is to determine the *D* value of the indicator micro-organism used to monitor the process. With radiation sterilization, the *D* value is defined as the dose of radiation in Mrads or kilograys\* necessary to produce a 90% reduction in the number of indicator microbial cells. The *D* value depends on such factors as temperature, moisture, organism species, oxygen tension, and the chemical environment and/or phys-

\*1 megarad = 10 kilogray.

ical surface on which the indicator microorganism is present. *D* values of different organism species in different suspending media are summarized in Table 7 [37].

*Bacillus pumilus* spores are the USP choice as the biological indicator for radiation sterilization. If a probability of nonsterility of  $10^{-6}$  is specified for a

**Table 7** Radiation Resistivities (Expressed as *D* Values) of Various Micro-organisms

Species	<i>D</i> value (Mrad)	Presence of a “shoulder” (Mrad)	Medium
Anaerobic spore formers			
<i>Clostridium botulinum</i> <sup>a</sup>			
Type A NCTC 7272	0.12	0.9–1.0	Water
Type B 213	0.11	0.9–1.0	Water
Type D	0.22	0.25–0.35	Water
Type E Beluga	0.08	0.25–0.35	Water
Type F	0.25	0.25–0.35	Water
<i>Clostridium sporogenes</i> <sup>a</sup>			
PA 3679/S2	0.22	0.25–0.35	Water
NCTC 532	0.16	0.25–0.35	Water
<i>Clostridium welchii</i> ( <i>perfringens</i> ) <sup>a</sup>			
Type A	0.12	0.25–0.35	Water
Type B	0.17	0.25–0.35	Water
Type F	0.20	0.25–0.35	Water
<i>Clostridium tetani</i> <sup>a</sup>	0.24	0.25–0.35	Water
Aerobic spore formers			
<i>Bacillus subtilis</i> <sup>b</sup>	0.06	—	Saline + 5% gelatin
<i>Bacillus pumilus</i> E 601 <sup>c</sup>	0.17	1.1	Water
Vegetative bacteria			
<i>Salmonella typhimurium</i> R 6008 <sup>d</sup>	0.13	0.4	Phosphate buffer
<i>Escherichia coli</i> <sup>e</sup>	0.009	—	Phosphate buffer
<i>Pseudomonas</i> species <sup>d</sup>	0.003–0.006	—	Phosphate buffer
<i>Staphylococcus aureus</i> <sup>e</sup>	0.02	—	Phosphate buffer
Molds			
<i>Aspergillus niger</i> <sup>b</sup>	0.047	—	Saline + 5% gelatin

<sup>a</sup>Roberts, T. A., Ingram, M. *J Food Sci* 30:879 (1965).

<sup>b</sup>Lawrence, C. A., Brownell, L. E., Graikoski, J. T. *Nucleonics* 11:9 (1953).

<sup>c</sup>Van Winkle, W., Borick, P. M., Fogarty, M. In: *Radiosterilization of Medical Products*. Vienna: IAEA (1967).

<sup>d</sup>Thornley, M. J. IAEA Tech. Rept. Series 22 (1963).

<sup>e</sup>Bellamy, W. D., Lawton, E. J. *Ann NY Acad Sci* 59:595 (1955).

Source: Adapted from Ref. 37.

system sterilized by radiation and the *D* value of *B. pumilus* in that system is 0.20 Mrad, a radiation dose of 1.2 Mrads would produce a 6-log reduction in the concentration of *B. pumilus* spores. Greater probability allowances (e.g.,  $10^{-3}$ ) would permit lower radiation doses.\*

The development of radiation sterilization cycles follows requirements of the Association for the Advancement of Medical Instrumentation (AAMI) [38].

1. Determine microbial load on preirradiated products.
2. Determine the *D* value for natural flora on the product.
3. Determine the *D* value using biological indicators on the product to make certain that the natural flora are not more radioresistant than the biological indicator.
4. Determine the *D* value of biological indicator spore strips placed within the product. Determine the location of the lowest radiation dose point within the product. Then determine the dosage required for a  $10^{-6}$  probability of nonsterility for the product.
5. Determine whether or not the *D* value for the biological indicator varies as a function of the dose rate. With cobalt-60, dose rate differences are not of much concern (variance of 0.1–0.5 Mrad/hr), whereas electron beam sterilization might produce dose rate variances of several Mrads per min!

The microbiological studies above are conducted to establish the appropriate dose level to be used to sterilize each specific product or commodity to an acceptable level of statistical nonsterility. These studies should be conducted following qualification of the irradiation facility. The Health Industry Manufacturers Association (HIMA) [39] has suggested major items to be included in the qualification phase of the validation scheme for radiation sterilization installation.

1. Specifications of the irradiator equipment—description, materials used, instrumentation, etc.
2. Drawings of the equipment and the entire facility
3. Licensing agreement and supporting documentation from both the Atomic Energy Commission and the appropriate state
4. Reliability and calibration of the dosimeter system
5. Radiation source strength when the sterilization cycle is validated through *D* value determination
6. Speed of conveyor belt
7. Dose rate

---

\*Also, validated reduced bioburden (e.g., 0–1 colony-forming units (CFU) per unit surface area or mL) would allow for a reduction in the radiation dose required to achieve a sterility assurance level of  $10^{-6}$ .

If it is assumed that the radiation sterilizer equipment and facilities have been qualified and microbiological studies have been conducted as previously outlined, the next step in the validation process is the complete evaluation of the radiation sterilization cycle. Tests are conducted to determine the effect of minimum and maximum product density on the ability of the minimum or nominal radiation dose—determined during the microbiological studies to produce a given log reduction in the biological indicator population—to sterilize the load. For example, it was found that a 0.2-Mrad dose of cobalt-60 will produce a 1-log reduction in the population of *B. pumilus*. The microbial load of a one-package polyvinyl chloride (PVC) device (intravenous administration site) was estimated to be approximately 1000. A probability of a nonsterility level of  $10^{-6}$  is desired, therefore theoretically, the minimum dose necessary to produce a 9-log reduction in the microbial population is 1.8 Mrad.

Validation tests must be conducted in such a manner that the following questions are answered:

1. Is the nominal radiation dose sufficient to destroy *B. pumilus* spore samples at a relatively high concentration (e.g.,  $10^8$  spores per ml or per strip) using a minimum load of product (minimum density)?
2. Is the nominal radiation dose sufficient to destroy *B. pumilus* spore samples at a relatively high concentration (e.g.,  $10^8$  spores per ml or per strip) using a maximum load of product (maximum density)?
3. What is the radiation sterilization efficiency; that is, how much of the applied dose is actually absorbed by the product?
4. What is the isodose profile for each irradiated item; that is, what is the dose of radiation absorbed as a function of the location within the product being irradiated? What is the ratio between the highest and lowest doses absorbed within the product?
5. What is the effect of conveyor loading conditions and line speeds on the amount of radiation absorbed?

As these questions are answered, adjustments probably will be made in the process. For example, it might be concluded that a higher radiation dose is required for adequate exposure to all points of a particularly large and/or dense container system. The loading size or pattern may have to be reduced to permit adequate sterilization at a given dose level. Once all process parameters have been defined through preliminary testing, the tedious but essential task of proving consistency, repeatability, and reliability of the radiation sterilization cycle must be established. Test records, data work sheets, and monitoring systems schedules must be kept and organized for easy retrieval and analysis.

While radiation sterilization cycles are validated based upon the achievement of sterility, many other factors must be considered in the utilization and approval of the radiation sterilization process. Such factors include the effect of

irradiation on (1) the physical appearance of the container system and its contents, (2) stability of the active ingredient, if present, and (3) safety of the irradiated material.

## IX. VALIDATION OF STERILIZING FILTERS

### A. Introduction to Filtration

The following definitions will be helpful in using this section. *When filter is used as a verb* (“to filter”) it means to pass a solid–liquid mixture through a permeable medium to cause a separation of the two. *Filter when used as a noun* refers to a device for carrying out filtration, and it consists of the filter medium and a suitable holder for constraining and supporting it in the fluid path. The permeable material that separates solid particles from the liquid being filtered is called the *filter medium*. The *unit operation of filtration*, then, is the separation of solids from a liquid by passage through a filter medium. In many instances, the filter, including the permeable medium, the means for passing liquid through the medium, and the process piping, are all referred to by the term *filter system*.

In general, filtration objectives can be separated into four basic categories: to save solids and reject liquids, to save liquids and reject solids, to save both liquids and solids, and to reject both liquids and solids [40].

As a filtration process proceeds, generally under an applied driving force of pressure, solids are removed by and begin to accumulate on the filter medium. The liquid portion continues to move through the filter medium and out of the filter system. The separated liquid is referred to as the *filtrate*. The amount of pressure applied to accomplish the filtration depends on the filtration resistance. *Filtration resistance* is a result of the frictional drag on the filtrate as it passes through the filter medium and the accumulated solids. In equation form,

$$\text{Filtration rate} = \frac{\text{pressure}}{\text{resistance}} \quad (13)$$

*Permeability* is often referred to as a measure of liquid flow through a filter system and is the reciprocal of the filtration resistance.

During filtration, as the particulate buildup continues on the filtration medium, the filtration resistance increases, or in other words, the filtration permeability decreases. The capacity of a system, expressed in time, volume of liquid fed, or amount of solids fed, depends on the ability of the system to maintain acceptable permeability.

When operating a filtration system, it is important to note the following general relationship:

$$\text{Retention} \times \text{permeability} = \text{constant} \quad (14)$$

Therefore, in attempting to have a certain degree of filtration efficiency or retention, a high rate of filtration, and the lowest possible cost, it is necessary to make a compromise with one or more of the above factors. A high permeability or low resistance for large filtration flow rates requires a filter medium of low retention efficiency. A highly efficient retention will have low permeability, low flow rates, and higher filtration costs.

## **B. Sterile Filtration**

Production of parenteral drugs requires that the product be sterile. In many cases, terminal sterilization by heat, ethylene oxide gas, or ionizing radiation is used to render a product sterile; however, certain products are not stable when exposed to heat, gas, or radiation, and they must be sterilized by other means. Filtrative sterilization is suitable in such cases. Indeed, the practice of sterile filtration is not limited to labile preparations. Unlike the other forms of sterilization, filtration sterilizes by the removal of the bacteria from the product rather than by inducing a lethality to the micro-organism. Filtration is straightforward and reliable; it removes particulate matter other than microbiological; it avoids possible pyrogenicity owing to the presence of dead bacteria in the dosage form; it is cost effective and energy efficient; and it allows convenient and flexible manufacturing systems and schedules with low capital investment [41].

Sterile filtration processes are employed to sterile-filter a product prior to filling it aseptically into its final containers. Bulk drug solutions are sterile-filtered prior to aseptic crystallization, thus eliminating the possibility of having organisms within the bulk drug crystals. The bulk drug can then be processed into a dosage form aseptically or further processed to be terminally sterilized. Other filtrative operations reduce the organism content of a final product prior to terminal sterilizations.

As noted earlier, a highly efficient retentive media will have low permeability, low flow rates, and higher filtration costs than other less retentive filter media. The highly retentive filter media used for sterilization have a short useful life because they clog very easily. Consequently, most filtration processes cannot be efficiently or economically carried out without the use of prefiltration. Prefiltration filter media are used to protect and thus lengthen the useful life of the final membrane filter media by collecting the bulk of the particulate material so that the membrane filter media must filter out only a small portion of the particulate. Prefiltration media are normally depth-filter media having a relatively wide pore and size distribution. A properly selected prefilter must meet the following conditions: (1) it must be retentive enough to protect the final membrane filter medium; (2) the prefilter assembly must not allow fluid bypass under any condition; (3) the prefilter system must be designed to make use of the prefilter medium; (4) it must have the best retention efficiency (with depth-

filter media low pressure differentials and low fluid flux, accomplished by a multielement parallel design, are best); and (5) the prefilter medium must be compatible with the solution and not leach components into the solution or absorb components from the solution. One note of caution needs to be mentioned in reference to lengthening membrane filter media life. Organism growth can become a problem if filtration takes place over an extended period of time. During filtration, bacteria continuously reproduce by cell division and eventually find their way through the filter medium to contaminate the filtrate. For this reason, prolonged filtration must be avoided. The proposed CGMPs for large-volume parenterals state that final filtration of solutions shall not exceed 8 hr [42].

Sterilization by filtration is a major unit operation used in aseptic processes. Aseptic processes require the presterilization of all components of the drug product and its container. Then all of the components are brought together in a controlled aseptic environment to create the finished sterile product sealed within its container/closure system. The level of sterility attained by an aseptic procedure is a cumulative function of all the process steps involved in making the product. Therefore, the final level of sterility assurance for such a product cannot be greater than the step providing the lowest probability of sterility. Each step in the aseptic process must be validated to known levels of sterility assurance [43].

This section will concentrate on that portion of the aseptic process wherein the drug product is sterilized by filtration. From the earlier discussion, sterile filtration is perhaps a misnomer, since the “sterile” filtrate is almost always processed further under aseptic conditions, which involves a risk of contamination [44]. Therefore, to speak of drug product sterilization by filtration as being as final a processing step as the steam sterilization of a product could possibly lead to erroneous assurances or assumptions. Since a sterile filtrate can be produced by filtration, however, we will continue to refer to the process as product sterilization by filtration.

The primary objective of a sterilizing filter is to remove microorganisms. The filter medium used to accomplish such an efficient retention may be classified as one of two types—the reusable type or the disposable type.

The reusable filter media are made of sintered glass, unglazed porcelain, or diatomaceous earth (Table 8). Because these filter media may be used repeatedly without being destroyed, they are less costly; however, the use of reusable filter media demands that the media be cleaned perfectly and sterilized prior to use to prevent microbial contamination and chemical cross-contamination. Even after exacting and painstaking cleaning processes have been used on reusable filter media, most companies using sterile filtration have decided that the risk of contamination is still great and prefer the use of the disposable media that are used once and then discarded. The remainder of our discussion will concern the disposable media, often referred to as membrane filter media.



**Table 8** Reusable Sterilizing Filter Media

Type	Manufacturer	Comments
Diatomaceous earth candles	Allen Filter Company, Toledo, OH	Fragile to handling, adsorptive alteration of solutions, difficult to clean, leachables, large pore size
Unglazed porcelain candles	Seals Corp. of America, Flotronics Division, Huntingdon Valley, PA	Fragile to handling and thermal shock, difficult to clean
Sintered glass	Kimble Division, Owens, IL, Toledo, OH	Fragile to handling and thermal shock, low pressures required, difficult to clean, smallest pore 4–5.5 $\mu\text{m}$

Membrane filter media are available from several different manufacturers and are made from many different materials. (See [Table 9](#).) Filter media consist of a matrix of pores held in a fixed spatial relationship by a solid continuum. The pores allow the product solution to pass through the medium while retaining the unwanted solid particles and micro-organisms. The size of filter medium pores to retain micro-organisms must be quite small. The 0.20- or 0.22- $\mu\text{m}$  pore size filter media are considered to be capable of producing sterile filtrates.

The characteristics of a given membrane filter medium depend on its method of manufacture: whether by phase separation of casting solutions, by adhesion into an organic union of matted fibers, or by track etching of solid films [45]. The retention of micro-organisms by the various membrane media, while not fully understood, has been investigated by numerous researchers who have indicated that several mechanisms are responsible. The dominant mechanism of retention is sieve retention. Particles larger than the pore size of the filter medium are retained on the medium, and as large particles are retained, pore openings can become bridged and thereby effectively reduce the filter medium's pore size. Other possible mechanisms of retention are adsorption of the particles into the medium itself, entrapment in a tortuous path, impaction, and electrostatic capture. [46]. The importance of these latter retention mechanisms has not been fully determined, and on the whole filtration sterilization is treated as depending on the steric influences of the sieve retention mechanism. The problem with assuming a sieve retention mechanism is that a sieve or screen has uniform openings, whereas a membrane filter medium does not. The filter medium has a distribution of pores, albeit narrow, rather than pores of a single-size. In addition, thinking in terms of a sieve or screen conjures up a vision of precisely measured and numbered openings. Precise methods for computing

**Table 9** Selected 0.2/0.22  $\mu\text{m}$  Membrane Filter Media

Composition	Mfg.	Designation	Thickness ( $\mu\text{m}$ )	Porosity (%)	Flow Rate, $\text{H}_2\text{O}$ (ml/min/cm <sup>2</sup> ) (pressure diff. 10 psi)	Autoclave
Mixed ester of cellulose	Millipore <sup>a</sup>	MF-Millipore	150	75	21	Yes
	Nuclepore <sup>b</sup>	Membra-fil	150–200	75	18	Yes
Cellulose acetate	Millipore	Celotate	150	71	16	No
	Sartorius <sup>c</sup>		120	—	18	Yes
	Gelman <sup>d</sup>		130	—	35	No
Nitrocellulose	Nuclepore	—	150–200	72	17	Yes
	MFS <sup>e</sup>	—	140	72	20	Yes
	Sartorius	—	130	—	18	Yes
	Whatman <sup>f</sup>	WCN	140	72	20	Yes
Polytetrafluoroethylene	Millipore	Fluoropore	175	70	20	Yes
	Nuclepore	Filinert	150–200	70	20 (methanol)	Yes
	MFS	Teflon	—	78	15 (methanol)	Yes
	Sartorius	PTFE	65	—	9 (isopropanol)	Yes
	Gelman	Teflon TF200	175	—	15 (methanol)	Yes
	Whatman	WTP	—	78	15 (methanol)	Yes
Nylon	Pall <sup>g</sup>	Ultipor N <sub>66</sub>	—	—	—	Yes
Polyvinylidene fluoride	Millipore	Durapore	125	75	12	Yes
Polycarbonate	Nuclepore	—	10	10	15	Yes
Regenerated cellulose	Sartorius	—	90	—	18	Yes
	Gelman	Alpha MetriceI-200	65	—	28 (acetone)	Yes
Polyamide	Sartorius	—	140	—	18	No
Acrylonitrile/PVC/nylon	Gelman	Acropore AN200	125	—	20	No

<sup>a</sup>Millipore Corporation, Ashby Road, Bedford, MA 01730.

<sup>b</sup>Nuclepore Corporation, 7035 Commerce Circle, Pleasanton, CA 94566.

<sup>c</sup>Sartorius Filters, Inc., 26576 Corporate Ave., Hayward, CA 94545.

<sup>d</sup>Gelman Sciences, Inc., 600 South Wagner Rd., Ann Arbor, MI 48106.

<sup>e</sup>Micro Filtration Systems, 6800 Sierra Court, Dublin, CA 94566.

<sup>f</sup>Whatman Laboratory Products, 9 Bridewell Place, Clifton, NJ 07014.

<sup>g</sup>Pall Trinity Micro Corporation, Cortland, NY 13045.

both numbers and the actual sizes of pores in a filter membrane medium are not available.

Many approaches have been taken in an attempt to measure the size of membrane filter media pores [47,48]. Flow measurements, both of air and of water, have been made. Mercury intrusion under high pressure has been employed, and pore sizing using either molecular templates or particles, including bacteria of known size, has been tried. The numerical values for pore sizes from these methods are based on a derivation from a particular model selected. Each of the various models has difficulties and shortcomings, and a pore size designation based on one method does not necessarily mean that a filter medium with the same designated size but from a different method really is the identical size [49]. More important, relating such a designated pore size to the membrane's ability to retain certain size particles may be anywhere from merely uncertain to misleading. Therefore, a given membrane filter medium with a designated pore size of 0.2 micron should not be thought of as "absolutely retaining all particles greater than 0.2 micron" without challenging the medium with a known size particulate. In fact, filter media should not be thought of as "absolute retentive" devices at all. It has been demonstrated that under certain operational conditions or with certain bacterial challenges, 0.2 micron-rated membrane filter media can be penetrated by bacteria. Filter media companies do challenge their products to ensure retention efficiency to sterility [46,50–52].

In addition to the pore size-particle size retention relationship problems mentioned above, other factors can influence a filter medium's retention characteristics. Absorptive retention can be influenced by the organism size, organism population, pore size of the medium, pH of the filtrate, ionic strength, surface tension, and organic content. Operational parameters can also influence retention, such as flow rate, salt concentration, viscosity, temperature, filtration duration, filtration pressure, membrane thickness, organism type, and filter medium area [52,53].

The complexity of the sterile filtration operation and the CGMP regulations require the validation of sterilizing filter systems. The validation of a sterile filtration operation can be complex, with many operational parameters and their interactions needing to be identified, controlled, and predicted for each end product to demonstrate that sterility is adequately achieved by the filtration process. In the commonly used steam sterilization process, the heat parameters are identified and in-process controls specified such that a level of sterility assurance can be reproducibly obtained. In steam sterilization, the important parameter of heat, measured by temperature, can be accurately measured and continuously monitored to ensure the operational integrity of the autoclave; however, unlike steam sterilization, filtration sterilization cannot be monitored on a continuous basis throughout the process.

The important aspect of filtration sterilization, the membrane filter me-

dium—its pore size, pore size distribution, integrity, and capacity—cannot be monitored during use. Therefore, the prediction that a filter membrane, given a certain set of operational parameters, will produce a sterile filter is critical. The only way to test a membrane filter medium's ability to retain bacteria is to challenge the medium with bacteria. Unfortunately, after a challenge with bacteria the filter membrane cannot be used again. Therefore, nondestructive tests need to be developed by which a filter can be tested as to its suitability for bacterial retention. Consequently, the approach in filter system validation has been to establish a reproducible relationship between a membrane's pore size and its bacterial retention efficiency. The thinking is that once such a relation is established, a nondestructive physical test can be developed by which each filter membrane medium can be tested and its bacterial retention efficiency assured. Testing of the membrane can then be performed both before and after use, and if the test results are satisfactory, the filtration process can be deemed to have been carried out successfully.

### C. Nondestructive Physical Tests for Pore Size Characterization

The theoretical basis for characterizing a membrane filter medium pore size and pore size distribution is based on the fact that a wet medium is impermeable to the bulk flow of a test gas until a certain pressure is attained that is sufficiently high to force the wetting liquid from the medium's pores. The pressure at which the transition from a nonflow to a bulk-flow situation occurs can be estimated in the following manner. First, the assumption must be made that the pores in the medium can be characterized as parallel cylindrical capillaries of circular cross section perpendicular to the membrane surface. Even though membrane pores are not normally found to be cylindrical, the assumption is made that they can be treated as cylindrical equivalents [48,54]. The transition pressure,  $P$ , can be estimated by equating the forces holding liquid in the cylindrical pores and the pressure forcing the liquid out of the pores.

In a given capillary of diameter  $D$  filled with a liquid that wets the capillary surface (Fig. 8) at any point along the circumference, the force component resisting the removal of the liquid is given by

$$f_r = \gamma \cos \theta \quad (15)$$

where

$f_r$  = point resistance force component

$\gamma$  = surface tension of the liquid

$\theta$  = contact angle of the liquid and the capillary wall

The total resisting force  $F_r$  is found by multiplying the point force  $f_r$  by the circumference.

$$F_r = \pi D f_r \quad (16)$$

$$F_r = \pi D \gamma \cos \theta \quad (17)$$

The resisting force  $F_r$  and the opposing transition pressure  $P$  can be equated, resulting in

$$P = F_r \quad (18)$$

$$\frac{\pi D^2}{4} = \pi D \gamma \cos \theta \quad (19)$$

$$P = \frac{4\gamma \cos \theta}{D} \quad (20)$$

For almost all practical purposes, the liquid wets the capillary wall so that the  $\cos \theta$  is taken as unity and the equation simplifies to

$$P = \frac{4\gamma}{D} \quad (21)$$

For example, by Eq. (21), the transition pressure for 0.2- $\mu\text{m}$  cylindrical pores is

$$P = \frac{4\gamma}{D}$$

$$P = \frac{4 \times 72 \text{ dyne/cm}}{0.2 \mu\text{m}}$$

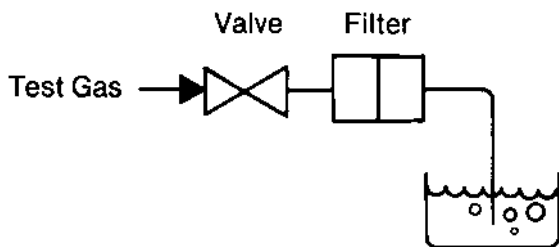
$$P = 1440 \times 10^4 \text{ dyne/cm}^2$$

$$P \text{ (in psi)} = 1.440 \times 10^7 \text{ dyne/cm}^2 \times 1.450377 \times 10^{-5} \text{ psi/dyne/cm}^2$$

$$P = 209 \text{ psi}$$

The cylindrical capillary model predicts that the size of the largest pore present in a membrane filter medium is inversely proportional to the pressure at which bulk flow of a test gas is not present.

The bubble point test is a popular single-point physical integrity test for disc filter membranes based on Eq. (21). A filter medium is wetted with a liquid, and test gas pressure is slowly raised until a steady stream of bubbles appears from a tube or hose attached to the downstream side of the filter and immersed in water (Fig. 9). The pressure at which the bubbles first appear is recorded as the bubble point and is related to the largest pores in the filter medium. A pore size can be calculated from Eq. (21); however, it must be realized that the bubble point test does not measure the actual pore size, but only allows correla-



**Figure 9** Basic bubble point test setup.

tion of the measured capillary equivalent with some dimensional characteristic of the pore structure of the membrane medium [49,55].

The bubble point test, while popular, has some deficiencies that must be realized. First, there is variation in the operator detection of the test end point; that is, the first appearance of gas bubbles rising in the liquid. Some operators are able to see smaller bubbles than others. In a recent study, a panel of seven observers recorded the initial detection of a steady stream of air bubbles rising from a capillary held under water as the air pressure was gradually increased. The observers, who had received different degrees of training, identified the simulated bubble point as occurring at air flows of 5 to 50 mL/min corresponding to air pressures of 34 and 38 psi, respectively, for a 90-mm disc filter membrane [56].

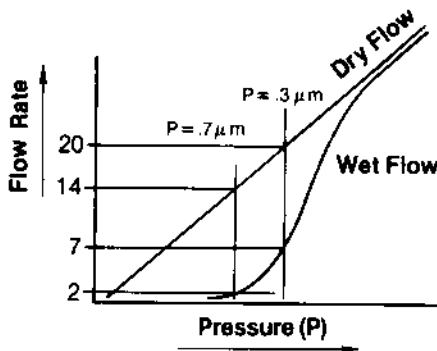
In Eq. (21), the surface tension of the liquid ( $\gamma$ ) is an important parameter in determining bubble point pressures, and it predicts that liquids of different  $\gamma$  values will have different pressures for the bubble point. In addition, it is a common assumption in Eq. (21) that the contact angle ( $\theta$ ) is 0, indicating a complete wetting of the filter medium by the test liquid. Tests have shown that this might not be a valid assumption in all instances [57]. Different medium materials show different bubble point values using the same test liquid. The change in wettability can affect testing before and after autoclaving. Autoclaving has been shown to wash away filter medium surfactants and thereby decrease the wettability, thus decreasing the bubble point pressure. Autoclaving has also been shown to decrease the hydrophobicity of a medium, thereby increasing the wettability of a membrane resulting in a higher posttest bubble point pressure [58].

As pressure is increased above the bubble point pressure, pores of decreasing size have the liquid forced out, and this allows additional bulk flow of the test gas. By measuring and comparing the bulk gas flow rates of both a wetted and a dry filter medium at the same pressure, the percentage of the bulk gas

flow through the medium pores that are larger than or equal to the size tested may be calculated. By increasing the test pressures in very small increments and determining the flow contribution of the corresponding pore size increments, it is possible to determine a pore size distribution for the filter medium [47,48,59].

The pore size distribution determination is illustrated in Figure 10. Again, the pore size distribution determination method does not result in the actual membrane pore size and pore size determination. It does, however, give a means of comparing different filter media. A narrow pore size distribution is required for effective filtration and filtration validation.

Another integrity test referred to as the pressure hold test makes use of the fact that below the transition pressure no bulk flow of the test gas takes place. Therefore, in a pressure hold test, once a filter system is in place and the filter medium wetted, pressure is applied to the system and then shut off and sealed. If there are no leaks in the system or holes in the membrane larger than the corresponding test pressure used, the pressure should remain constant. If the pressure drops, there is a leak somewhere in the system that should be corrected. The pressure hold test is popular in testing filter assemblies and systems in



$$\begin{aligned} \% \text{ Flow} &= \left( \frac{\text{Wet Flow, High P} - \text{Wet Flow, Low P}}{\text{Dry Flow, High P} - \text{Dry Flow, Low P}} \right) \times 100\% \\ &= \left( \frac{7 - 2}{20 - 14} \right) \times 100\% \\ &= (.35 - .143) \times 100\% \end{aligned}$$

$$\% \text{ Flow} = 21\%$$

21% of the fluid passing through the filter moves through pores between 0.7 and 0.3 μm.

**Figure 10** Pore size distribution determination example. (From Ref. 59.)

production situations before and after filtration as a quick integrity check of the system.

Another problem with the use of the bubble point test develops as one begins to test large volume disk-type membranes (293 mm) and the pleated cartridge-type filter media that have large surface areas available for filtration. Bubble point measurements are inaccurate with these high-surface-area filters because of several problems. With the larger systems, enough test gas can go into solution under the test pressure to form visible gas bubbles when the solution reaches the downstream side of the filter and the test pressure is released. Observers, seeing the pressure release bubbles, would record the pressure at that point in the experiment as the bubble point and hence mark the filter medium as a failure because the bubble point pressure was low, indicative of large pore sizes in the membrane medium. With the cartridge systems, initial bubble point gas bubbles tend to rise within the core of the filter rather than leave the filter. In this case, the first appearance of the bubbles is viewed at a pressure level higher than the real transition pressure, and defective cartridges could be approved for use when really unsuitable [58].

With large-surface-area membrane filter media, the interpretation of the true bubble point can be further complicated because of the diffusion of the test gas through the media. Because the filter media are more than 70% void space, a liquid-wetted membrane is virtually a thin film of liquid across which a test gas will diffuse, governed by Fick's law.

$$Q = \frac{D(C_1 - C_0)\phi}{h} \quad (22)$$

where

$Q$  = molar flux of test gas per unit area and unit

$D$  = diffusion coefficient for the gas-liquid system used

$\phi$  = void fraction of the filter medium used

$h$  = thickness of the membrane

$C$  = concentration of the gas; 1 = upstream, 0 = downstream

Because the solubility of the gas in the liquid is low by virtue of Henry's law, the solubility can be expressed in terms of pressure.

$$C_1 - C_0 = H(P_1 - P_0) \quad (23)$$

where

$H$  = solubility coefficient for the gas-liquid system

$P_1$  = upstream pressure

$P_0$  = downstream pressure

If the downstream side of the filter vented to the atmosphere then  $P_0 = 0$ . With the appropriate substitution, Eq. (22) can be rewritten as



$$Q = \frac{DHP\phi}{h} \quad (24)$$

where  $P$  = applied test pressure upstream.

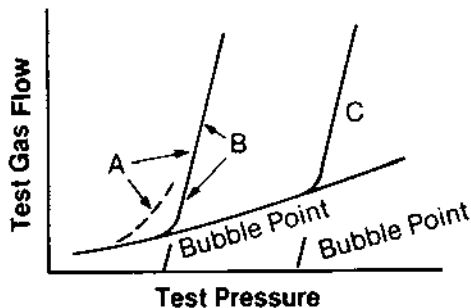
For a given test  $D$ ,  $H$ ,  $\phi$ , and  $h$  would be constant. Therefore

$$Q = KP \quad (25)$$

and  $Q$  should be predictable for a given pressure. As long as the transition pressure is not reached,  $Q$  and  $P$  should be linearly related.

Figure 11 shows the wet-flow properties of three hypothetical membrane filter media. Each filter medium is made of the same material and has the same thickness and total void fraction. Media A and B have the same oversized pore size, but A has a broader pore size distribution. Medium C has a pore size smaller than A and B with a narrow pore size distribution.

The diffusion flow test is not without its difficulties or potential problems, however; if the filter traps liquid and essentially forms a secondary liquid layer in addition to the medium, the diffusional flow will, of course, be decreased. A test pressure that is too low will not be able to differentiate between good media and media that will pass bacteria because the test pressure will be below even the largest pore bubble point; the only flow reading obtained will be diffusional flow through the support media, and they will be almost identical for each size medium [60]. The recommended single-point diffusion test pressure is 80% of the bubble point. To run such a diffusion test, the medium to be tested is placed in its filter assembly and the medium is thoroughly wetted with a liquid and the filter assembly drained. Pressure from a test gas, generally air or nitrogen, is



**Figure 11** Diffusional wet-flow characteristics of three hypothetical membranes. (From Ref. 61.)

then slowly increased up to approximately 80% of the estimated bubble point pressure for the given medium and liquid used. The resulting flow of test gas is then quantitatively measured. In the past few years, the sophistication of equipment to run this test has steadily increased to such a point that some firms now offer automatic instruments for running diffusion tests [69].

Diffusion tests have been complicated by the diffusion coefficient's being changed for the gas-liquid system after the membrane has been autoclaved [58]. With the introduction of additional layers of media material to large cartridge filters, additional problems have also arisen. The additional media can possibly affect the drainage of liquid from the filter prior to flow testing. If all of the liquid is not removed, the possibility exists for additional liquid layers to reduce the diffusion effectively or for thicker liquid layers in the medium to retard diffusion. The additional medium material itself adds thickness and therefore decreases diffusional flow. The reduced diffusion readings, in turn, could mask larger pores and flaws if this is not dealt with in designing the tests [55]. Additional nonlinearity with the pressure-gas flow relationship has been reported as attributable to a process known as liquid thinning. As the test gas pressure is increased to near the true bubble point of the medium but not below it, the average thickness of liquid held in the medium decreases. The amount of gas diffusion per unit pressure therefore increases, and the relationship becomes nonlinear [60].

The search for the ideal nondestructive test of a sterilizing filter system is still proceeding. One new suggestion has been proposed to use test gas pressures above the bubble point. In the meantime, the wise user of filter systems for sterilization will test in as many ways as possible and correlate for physical tests with bacterial challenge tests.

There are additional characteristics of filter media that need to be addressed in a total validation scheme for filter systems. While a thorough discussion of them is beyond the scope of this discussion of sterilization, they are mentioned below. Particles and soluble materials can be rinsed from various process filter media and must be considered as contaminating any parenteral preparation, therefore steps should be taken to isolate, identify, and eliminate these contaminating substances prior to use. Solid extractables have been shown to be pieces of the filter medium itself (media migration) or "cutting" debris. Soluble contaminants in parenterals have been isolated from filter aids, from upstream prefilters, and from the sterilizing filter medium itself. In general, extractables from a membrane filter medium can be categorized into either plasticizers or surfactants. The surfactants found have been nonionic ethylene oxide adducts, polyvinylpyrrolidone, long-chain fatty acid-substituted polyethylene glycol, and alkylated cellulose. The plasticizers have been found to be glycerol or polyethylene glycol [62]. The filter media should also be tested for compatibility with each parenteral drug product, presence of induced nonpyrogenicity, and biological toxicity.

## D. Filter Qualification

Technical report no. 26 from the Parenteral Drug Association [63] identifies the following factors that should be part of selecting and qualifying a filter for use as a product sterilizing filter:

1. Particle-shedding characteristics
2. Extractables
3. Chemical compatibility
4. Adsorption
5. Thermal stress resistance
6. Hydraulic stress resistance
7. Toxicity testing
8. Bacterial challenge testing
9. Physical integrity testing

Physical integrity testing has already been discussed. Subsequent discussion will focus on extractables and bacterial challenge testing.

## E. Bacterial Challenge Test

Microbiological challenging of a filter is the only true means of determining the bacterial retention properties of the system. Such a test is sensitive because of the large number of organisms used and because the organism self-replicate and allow even low numbers of bacteria that might pass through a filter system to make themselves known.

Filter media are not repetitive-use items, and although used for more than one lot in production, the media are usually discarded after some predetermined number of uses or time. Therefore, it is impossible to test every filter medium individually, since the challenge test is a destructive test. The nondestructive tests, therefore, require a high degree of correlation with a retention test. When such correlated tests are established and controls maintained, filtration users can depend on filtration to produce a sterile parenteral product.

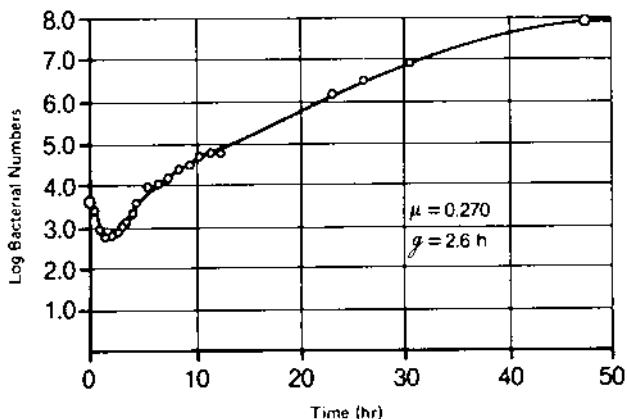
The level of sensitivity of the challenged test is dependent on the challenge organism, culture environment of the organism, challenge level of the organism, test volume filtered, challenge rate or the duration of the challenge test, and pressure used during the challenge test [63,64].

In 1987, FDA published its guideline on validation of aseptic processing [43] specifying requirements for challenging filters with  $10^7$  cells of *Pseudomonas* (now *Brevundimonas*) *diminuta* per  $\text{cm}^2$  of filter surface and for validating aseptic processes using sterile media fills.

The challenge organism utilized in filter testing is *Brevundimonas diminuta* (ATCC 19146). The rationale for using *B. diminuta* follows the same logic as used in choosing *B. stearothermophilus* for steam sterilization testing. *Bacil-*

*lus stearothermophilus* is resistant to heat and therefore severely challenges the lethality given by an autoclave. Because filtration is a removal process, the most resistant organism to filtration would be the smallest known bacterium. *Brevundimonas diminuta* has been adopted for several reasons. First, the organism is quite small. The gram-negative rod-shaped cell has a mean diameter of 0.3  $\mu\text{m}$ . The bacteria were first isolated when found to consistently pass through 0.45- $\mu\text{m}$  filter membranes to contaminate filtered protein solutions. The organism can be grown to high cell densities in a short period of time, and with proper culturing the cells are small and arranged singly. In addition, *B. diminuta* shows only limited biochemical activity. A growth curve for *B. diminuta* in saline-lactose broth (SLB) at 30°C is shown in Figure 12. The initial lag time lasts about 3 hr. In the exponential growth phase, the organism has a population doubling time (generation time) of 2.6 hr and an instantaneous growth rate constant ( $\mu$ ) of 0.27 hr<sup>-1</sup>. The growth curve levels off in the stationary phase at approximately 10<sup>7</sup> cells/mL [65].

For reproducible challenge tests, care must be taken in culturing and handling the bacteria to maintain bacterial cells of equal morphology. Studies have shown that differences in cell morphology can be produced by using different growth media or by the use or nonuse of agitation during culturing. *Brevundimonas diminuta* grown in trypticase-soy broth (TSB) without agitation produces a cell that is distinctly rod-shaped, having a length-to-diameter ratio of 2 to 5. Grown in the same TSB medium but with 200 rpm agitation, *B. diminuta* was more dense and had longer cells with a length-to-diameter ratio of about 4. In



**Figure 12** Growth curve of *P. diminuta* (ATCC 19146) in saline-lactose broth incubated without agitation at 30°C. (From Ref. 72.)

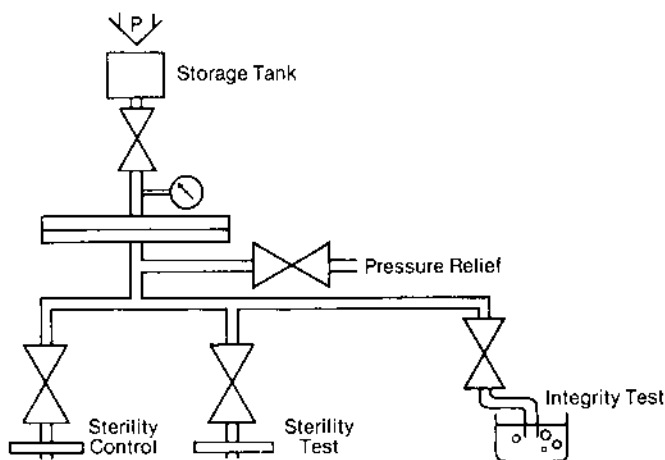
addition, the cells tended to form clusters of from 3 to 8 cells each. *Brevundimonas diminuta* grown in SLB without agitation are found to have a length-to-diameter ratio of 1 to 2.5 and are arranged singly [65].

The growth state of a *B. diminuta* culture is also important in obtaining the smallest cell size on a reproducible basis. *Brevundimonas diminuta* cells are observed to increase in cell size during the lag phase and become smaller during the declining growth period. Therefore, challenge cells for retention testing are most appropriate when in the early stationary phase of growth. Early stationary phase rather than late stationary phase is taken to reduce the chance of the challenge culture containing nonviable cells and cellular debris, which could prematurely clog the test filter medium.

Maintenance of a pure culture of *B. diminuta* must be done in such a manner as to keep the probability of mutational changes that might alter cellular characteristics to a minimum.

The microbial challenge test can be performed on a particular filtration medium, whether disk or cartridge type, by following these general steps:

1. Sterilize the filter system. Figure 13 shows a hypothetical test system for a disk filter medium.
2. Integrity test the filter medium using a sterile 0.1% peptone solution or saline solution to wet the medium. The wetting solution also serves as a negative control sterility check. The entire wetting solution is



**Figure 13** Hypothetical disk-filter bacterial challenge test apparatus.

forced through a sterility control filter, incubated, and checked for sterility.

3. The bacterial challenge suspension is placed in the appropriate container and the test filter medium is challenged.

The challenge suspension should have a microbial concentration of  $10^7$  *B. diminuta* per square cm of effective filter area (EFA). Many challenge levels have appeared in the literature:  $10^7$  per 100 ml for 1400 liters,  $10^5$ – $10^7$  per ml,  $2$ – $4 \times 10^5$  per liter per min,  $1.2 \times 10^{12}$ – $1.9 \times 10^{13}$  per liter, and  $10^8$  per  $\text{cm}^2$  EFA [44,50,64–68]. Much discussion has also appeared in the literature concerning the challenge level and the potential adverse effects of excessive levels of challenge bacteria [66]. The rationale for the  $10^7$  *B. diminuta* per  $\text{cm}^2$  EFA challenge is that while this level of bacteria might not challenge every membrane pore (approximately  $10^8$  pores per membrane medium), it is enough to challenge any oversized pore. Since the flow through pores varies as the fourth power of the radius of the pore, a larger fraction of the total flow is carried by the larger pores. Therefore, it is felt that at the  $10^7$  challenge level enough increased flow will pass through any oversized pores that challenge bacteria will inevitably encounter an oversized pore, pass through, and indicate a negative test. The  $10^7$  level is also under the filter-clogging concentration [10].

The challenge suspension should be forced through the test medium at a pressure differential greater than  $2 \text{ kg/cm}^2$  (approximately 30 psi) for disk filters and at fluxes of greater than 2 liters per  $0.1 \text{ m}^2$  up to around 3.86 liters per  $0.1 \text{ m}^2$  for cartridge-type filters [64,65]. A pressure relief valve on the downstream side of the filter should be provided to allow maximum pressure differentials. The suggestion has also been made that the pressure be applied full strength immediately rather than a gradual buildup in order to stress the filter system further [65].

4. The entire volume of the challenge filtrate is subsequently forced through a sterility test filter system and incubated in the same manner as the negative control filtrate.
5. A postchallenge integrity test is performed.
6. The challenge test results are then observed. The challenge tests are considered invalid if the negative control contains any organisms. The filter system is considered to have failed the test if the filtrate contains any test organisms.

## F. Extractables

Filter validation now includes tests to prove that sterilizing filters do not generate extractable materials when exposed both to water and to the drug product

formulation. Tests for filter extractables may be found in the USP, Section <87> Biological Reactivity Tests, in Vitro and Section <88> Biological Reactivity Tests, in Vivo. These tests involve soaking filter material in different solvents, then evaluating them in two animal models and in cell culture. USP Section <661> also describes testing of filters to ensure that no extraneous contaminants are found in the filter material. Filter extracts have been identified as surfactants, wetting agents, additives used in filter manufacture, higher molecular weight polymers of the filter polymer, and general particulates [69–71]. Extraction procedures with actual drug product may include immersing the filter into the drug product solution, then exposing it to high temperatures and mechanical agitation before taking samples and assaying by various analytical techniques [71].

### G. Retention Efficiency

In the past, several terms have been coined to describe the retention efficiency of the filter system: *beta value*, *microbiological safety index*, *reduction ratio*, and *titer reduction ratio* [64,68,72]. The *log reduction value* (LRV) is a filter retention efficiency term that is the logarithm to the base of 10 of the ratio of the number of organisms in the challenge suspension to the number of organisms in the filtrate.

$$\text{LRV} = \log \frac{N_0}{N} \quad (26)$$

$$\text{LRV} = \log N_0 - \log N \quad (27)$$

where

LRV = log reduction value

$N_0$  = number of organisms in the challenge

$N$  = number of organisms in the filtrate

With a sterile filtrate, the term  $\log N$  becomes  $\log 0$ , which is undefined and is eliminated from the expression. The LRV is then expressed as being equal to or greater than  $N_0$ .

$$\text{LRV} \geq \log N_0 \quad (28)$$

For example, if a 293-mm-diameter disk filter system having an EFA of 530  $\text{cm}^2$  is challenged and the  $10^7/\text{cm}^2$  level is used, the total challenge to the filter is  $5.3 \times 10^9$  organisms. If a sterile filtrate is assumed the LRV would be calculated and reported as follows:

$$\text{LRV} = \log 5.3 \times 10^9 - \log 0$$

$$\text{LRV} \geq 9.72$$

The probability of passing a single organism through this filter system, or in other words, the probability of nonsterility (PNS) can be calculated by the following equation:

$$\text{PNS} = \frac{N}{N_0} \quad (29)$$

For the above example, the PNS is calculated as

$$\text{PNS} = \frac{1}{5.3 \times 10^9} = 1.89 \times 10^{-10}$$

Equations (27) and (29) can be used to calculate the total PNS of replicated experimental filter challenges. For example, five filter membrane media are to be challenged at the following *P. diminuta* levels.

$$\begin{array}{ll} 18 \times 10^9 & 9 \times 10^9 \\ 5 \times 10^9 & 14 \times 10^9 \\ 12 \times 10 & \end{array}$$

The total challenge ( $N_0$ ) is  $5.8 \times 10^{10}$ , and the assumption is made that the filtrate for each is sterile. The LRV then is

$$\text{LRV} = \log N_0 - \log N = \log 5.8 \times 10^{10} = 10.76$$

The PNS then is calculated to be

$$\text{PNS} = \frac{N}{N_0} = 1.72 \times 10^{-11}, \quad N = 1$$

These equations may be used to calculate an estimate of the degree of nonsterility associated with a particular filtration process. In order to determine such a sterility assurance associated with the process, some knowledge of the initial microbiological bioburden of the product to be sterilized must be known. If it is assumed that the microbiological bioburden of a product is  $10^4$  organisms and the product is to be sterilized by filtration through filters from the example above, the PNS is the sum of all the probabilities of all of the combinations of the  $10^4$  organisms passing through the filter. The expression for this is

$$\text{PNS} = \sum_{n=1}^{N_0} P_i \quad (30)$$

where

$$\begin{array}{l} N_0 = \text{the bioburden of the product} \\ P_i = \text{probability of } i \text{ organisms passing the filter medium} \\ n = 1, 2, \dots, i \end{array}$$



In other words, the PNS is equal to the probability of one organism passing the filter plus the probability of two organisms passing the filter, and so on. With the bioburden level greater than one organism, however, there result many combinations of sets or organisms having a probability of passing the filter. The probability of all combinations of one organism passing a filter with a given retention efficiency from a bioburden level  $N_0$  can be written as

$$P_1 = \frac{N_0!}{(N_0 - 1)!1} \quad (31)$$

$$1 \times RV$$

where

RV = reduction value

or in logarithmic form

$$\log P_1 = \log \frac{N_0!}{(N_0 - 1)!1} - LRV \quad (32)$$

Similarly, the probability of all combinations of  $i$  organisms passing the filter is

$$\log P_i = \log \frac{N_0!}{(N_0 - i)!i} - i(LRV) \quad (33)$$

When Eq. (30) is expanded into the format of Eqs. (32) and (33), the following expression results:

$$\log \text{PNS} = \Sigma \left[ \left( \log \frac{N_0!}{(N_0 - 1)!1} - LRV \right) + \dots + \left( \log \frac{N_0!}{(N_0 - i)!i} - iLRV \right) \right] \quad (34)$$

In a convergent series, as in Eq. (34), the bracketed quantity representing  $P_1 \gg P_2 \gg \dots P_i$  can be approximated by using  $P_1$  only. Therefore, Eq. (34) can be simplified to

$$\log \text{PNS} = \log \frac{N_0!}{(N_0 - 1)!1} - LRV \quad (35)$$

This simplifies further to

$$\log \text{PNS} = \log N_0 - LRV \quad (36)$$

A sterility assurance (SA) can be calculated from

$$\text{SA} = 1 - \text{PNS} \quad (37)$$

By way of example, the LRV for the previous five-filter example was 10.76. If a product having a bioburden,  $N_0$ , of  $10^4$  organisms is to be filtered, the PNS can be calculated using Eq. (36).

$$\log \text{PNS} = \log N_0 - \text{LRV} = 4 - 10.76 = -6.76$$

$$\text{PNS} = 1.74 \times 10^{-7}$$

The SA can be calculated then by Eq. (37) where

$$\text{SA} = 1 - \text{PNS} = 1 - 1.74 \times 10^{-7}$$

$$\text{SA} = 0.9999998 \quad \text{or a } 99.99998\% \text{ assurance of sterility}$$

Terminally sterilized parenteral products have a level of SA in the range of 0.999999. If we assume that our example solution has 100 organisms per liter, how much could we filter before the SA dropped below 0.999999? By using Eq. (37)

$$\text{SA} = 1 - \text{PNS}$$

$$\text{PNS} = 1 - .999999 = 10^{-6}$$

When we substitute into Eq. (36) and rearrange

$$\log N_0 = \log \text{PNS} + \text{LRV} = -6 + 10.76 = 4.76$$

$$N_0 = 57,544 \text{ organisms}$$

When we use the following relationship

$$N_0 = C \times V \tag{38}$$

where

$N_0$  = the bioburden of the product

$C$  = the bioburden concentration per unit volume

$V$  = the volume of the product

then

$$V = \frac{N_0}{C} = \frac{57,544 \text{ organisms}}{100 \text{ organisms/liter}}$$

$$V = 575.44 \text{ liters}$$

Therefore, 575.44 liters can be filtered before going below an SA of 0.999999.

Data generated by the Millipore Corporation show that a mixed cellulosic ester membrane filter medium with an average bubble point of 3.44 kg/cm<sup>2</sup>, when challenged with an average of  $2.78 \times 10^7$  organisms/cm<sup>2</sup>, had an average LRV of 9.96. Millipore claims that 20 years of quality control testing has confirmed that mixed esters of cellulose filter media having a minimum bubble test of 3.3 kg/cm<sup>2</sup> or greater will quantitatively retain  $10^7$  *P. diminuta*/cm<sup>2</sup> EFA at a differential pressure of 2.6 kg/cm<sup>2</sup>. Such is the type of correlative data that are needed to validate each product for filtration sterilization [69].

## H. Aseptic Processing [43,73–75]

Aseptic fill processes are validated by simulating production conditions and using a bacterial culture medium as the product. This process simulation test is commonly referred to as a “media fill.”

Production facilities must be checked to ensure that all installed equipment both satisfies the engineering and quality design criteria (installation qualification) and functions properly (operational qualification). In the performance of a media fill, it is important that everything be conducted just as a normal production run. All equipment normally used should be used. All equipment should be cleaned, sanitized, sterilized, handled, and assembled in a normal manner. All personnel normally involved in an aseptic process must participate in the media fill. Such personnel must have sufficient training in such areas as basic microbiology, personal hygiene, gowning techniques, manipulative techniques, safety, and cleaning procedures.

Table 10 provides a list of considerations for ensuring that every aseptic process is appropriately simulated during a media fill validation exercise.

Media fills are conducted to initially qualify a new filling line, a new product, and/or a change in product container configuration. Subsequent to ini-

**Table 10** Considerations for Ensuring Media Fill Runs Adequately Simulate Actual Production Runs

---

Duration of longest run
Multiple runs on separate days
Worst-case environmental conditions
Number and type of interventions, stoppages, adjustments, transfers; both planned and unplanned (e.g., replacing filling needles, pumps, filters, stopper bowl stopping line, removing all containers, manual stoppering)
Aseptic assembly of equipment
Maximum number of personnel normally present
Number of aseptic additions
Shift breaks, changes, multiple gownings
Number and type of aseptic equipment disconnections and connections
Aseptic sampling
Line speed and configurations
Manual weight checks
Operator fatigue (work time)
Container/closure types run on the line
Temperature and relative humidity extremes
Conditions permitted before line clearance
Container/closure surfaces that contact formulation during aseptic process

---

tial qualification, media fills are required on a semiannual basis to provide minimal assurance that good aseptic conditions and practices have been maintained.

Initial media fill qualification typically involves a minimum of three consecutive, separate, and successful media fills. The definition of successful has evolved from allowing one contaminated unit out of 1000 containers to having zero contaminated units.

Periodic requalification of aseptic processes with media fills every 6 months applies to every filling line, every product container configuration, and every aseptic process operator. Sometimes a requalification media fill will need to be conducted in intervals of less than 6 months if environmental monitoring data start failing acceptance limits, if there is personnel change, if a major manufacturing deviation occurred, or if equipment changes or modifications take place. A valid change control procedure needs to be in place to ascertain when changes in the manufacturing environment require a new media fill qualification.

Ideally, the maximum batch size should be simulated in the media fill. Practically, the number of units filled with media must be sufficient to reflect the effects of worst-case filling rates, including operator fatigue and the maximum number of interventions and stoppages. While 3000 vials are needed to detect with 95% confidence a contamination rate of one in 1000, using 3000 vials as a minimum number of units to be filled is no longer considered to be sufficient. The current regulatory position is to fill a minimum of 4750 units three consecutive times with zero positives. One positive in each of three consecutive runs is viewed as a serious process control problem. The International Organization for Standardization (ISO) has developed acceptance criteria (the maximum acceptable contaminated units in a media fill run) as a function of the number of media fill units.

Following a periodic requalification media fill, production may resume while media fill units are incubating. No product can be released until media fill data are analyzed and acceptance criteria are met, however.

Each lot of media must pass a growth promotion test (10 to 100 CFUs per container) following the media fill run and again after the end of the incubation period. Typically incubation of media involves a period of 7 days at 30–35°C to detect bacterial growth, followed by 7 days at 20–25°C for molds. Incubation conditions must be justified based on favored growth conditions for common environmental isolates. Prior to incubation, each unit must be inspected, with any leaking or damaged units removed. Each unit also must be rolled or inverted prior to incubation for media to contact all interior surfaces of the container.

Media fill failures can and do occur. Standard operating procedures must be in place to provide action steps in case of a media fill failure. Typically, if one of three runs fail, the entire sequence of three separate, consecutive media fill runs is repeated unless a clear assignable cause can be given to the failed

media run. If a requalification media fill fails (one run), there should be criteria in the procedure to determine whether a single repeat run or a repeat of the initial qualification (three runs) should be done. All documentation involved in a production process (e.g., environmental monitoring data and trends, personnel monitoring data and trends, sterilization charts, HEPA filter certification, filter integrity test data, handling and storage of all equipment) must be reviewed after a media fill failure.

For an aseptic filling process the level of sterility assurance is a cumulative function of all the unit operations involved in the entire manufacturing system. The final level of sterility cannot be greater than the unit operation providing the lowest probability of sterility. Adherence to a program that will enable the validation of all steps in the aseptic process from the solution preparation step to the final container closing/sealing step will provide the highest assurance possible that all steps of the process are collectively functioning and controlled to yield a product that is microbiologically safe.

## **I. Other Sterile Process Systems Requiring Qualification and Validation**

Historically, and even today, emphasis on the validation of sterile products is placed mainly on the sterilization processes. No manufacturing operation can be considered under complete control without qualification of every system that can potentially affect product quality, however. The following discussion will touch upon other systems and processes involved in sterile product manufacturing expected to be validated. Much of this section relies on the following literature sources [Refs. 43,73–80]. Also refer to other chapters in this book that discuss certain topics in much greater detail.

## **J. Facility Design and Construction**

The Good Manufacturing Practice (GMP) regulations, FDA, and European Economic Community (EEC) guidelines on aseptic processing, and other documents provide comprehensive details on facility requirements for sterile drug production. The facility must

1. Use HEPA filters for filtering the air supply to reduce or eliminate particulate contaminants
2. Maintain higher air pressures (positive pressure) within the critical areas to minimize infiltration of airborne contaminants from outside air
3. Provide smooth, easily cleanable surfaces on equipment, floors, walls, and ceilings to minimize the opportunity for collection of particulates and growth of micro-organisms

4. Provide temperature and humidity controls appropriate to the product being manufactured

## **K. Utility Qualification (see Chapter 12)**

Facility design is critical. Likewise, individual utilities require qualification. The most important of these are heating, ventilation, and air conditioning (HVAC), water (including clean steam), and compressed gases.

Typical programs begin with installation qualification (IQ). The IQ is described in a written protocol that contains the following key elements:

1. Equipment or system specifications
2. Spare parts list
3. As-built drawings
4. Wiring diagrams
5. Piping and installation
6. Installation certification statement

Following completion of the IQ, the equipment or system is subjected to operational qualification (OQ). This is a more rigorous exercise in which the object is to ascertain that the equipment or system being tested performs in accordance with design specifications throughout the full operational range(s). The OQ protocol contains

1. A full system description
2. Calibration certification documents
3. Testing plans
4. Acceptance criteria
5. Full record of testing results
6. Certification statement

### **1. Heating, Ventilation, and Air Conditioning (HVAC)**

Features of the HVAC system that affect product quality (sterility) and therefore require qualification include

1. HEPA filter integrity
2. Airborne particle control
3. Airflow direction
4. Room air pressure differentials
5. Temperature and humidity control

A popular method for certifying the integrity of the filter installation uses a polydisperse aerosol, created by blowing air through liquid (e.g., poly-alpha-olefin) introduced into the upstream ductwork, followed by scanning the entire downstream side of the filter face and periphery with a probe nozzle of an aerosol photometer. This testing will identify “leaks” caused by damage due to

mishandling or faulty construction. Small leaks can be repaired with a suitable silicone-based compound without removing the filter.

The importance of maintaining air pressure differentials in the enclosures of the aseptic suite within the ranges specified in the design plans cannot be overemphasized. Reversal of airflow, which can occur if the relative room pressures are upset, can allow contaminated air from a noncontrolled region into the clean room, thus defeating the purpose of the HEPA-filtered air supply.

Most enclosures in the aseptic processing suite are not airtight because of the need for conveyor lines and pass-through openings, so there is a very real opportunity for contamination from the noncontrolled adjacent manufacturing areas and particularly from overhead uncontrolled technical areas.

Special monitoring devices known as Magnahelic or Photohelic gauges measure the pressure differentials across a diaphragm and depict the value in terms of inches of water or some other convenient scale. These instruments are very accurate and sensitive to very small changes in pressure differential. Typically they are connected directly to an alarm system that will cause a visual signal (flashing light) or an audible signal (alarm buzzer) and/or trigger a recording device to report a deviation outside a prescribed range of pressure differential.

## 2. Water

Water quality is usually defined in terms of chemical and bacteriological purity, particulate matter content, and endotoxin levels. Potable water is normally from the municipal water system, which may have been treated with chlorine to control microbiological growth. Soft water and deionized water have undergone ion exchange or similar treatment to eliminate unwanted ionic species, such as  $Mg^{2+}$  and/or  $Ca^{2+}$ . Purified water, water for injection, and other types of water meeting compendial specifications are produced by ion exchange, reverse osmosis, distillation, or a combination of such treatments.

The validation protocol provides a detailed description of sampling locations and requirements, testing methodology, and test limits or specifications. Sampling and testing can be performed daily during qualification and validation. When the system is in routine use, following the validation the testing frequency can be reduced to a weekly schedule for monitoring purposes.

An action guideline of not more than 10 CFUs/100 ml for bacteriological purity is suggested. As with the purified water system, the sampling and testing frequency for the water for injection (WFI) system is defined in the protocol and can be reduced after the system is qualified and validated.

## 3. Compressed Gases

Various kinds of compressed gases (e.g., nitrogen, oxygen, and carbon dioxide) may be found in the sterile drug manufacturing plant; however, as an example only compressed air will be discussed.

Compressed air is one of the utilities that may have direct or incidental product contact and therefore requires qualification. The types of contaminants found in compressed air, not surprisingly, are the same as those found in the ambient environment. These may include micro-organisms (e.g., bacteria, molds, and viruses), moisture, particulate matter, and possibly pyrogens. Undesirable levels of hydrocarbons from compressor lubricants may be found if the compressor is not of the oil-free type.

A well-designed compressed air system eliminates or substantially reduces the levels of these contaminants. Components of such a system include the following:

1. An oil-free compressor—typically a rotary screw, multiple-stage design
2. An oil-coalescing filter to trap any liquid hydrocarbons or water
3. A dryer to remove condensed moisture and reduce levels of gaseous hydrocarbons
4. A filtration unit to eliminate gross particulate matter, such as fibers and metal particles
5. A sterilizing filter rated at 0.2  $\mu\text{m}$
6. A sanitary design receiver tank and distribution piping sloped for proper drainage
7. Instrumentation suitable for monitoring the temperature, pressure, and volume or flow rate in the system

Installation and operational qualification work includes verification of temperature, pressure, and flow rates, instrument calibration, and thorough flushing of the entire system to remove oil, metal particles, and other contaminants. The type of testing and acceptance limits listed in the validation protocol may vary from firm to firm; however, compressed air with product contact should be tested for such quality attributes as hydrocarbons, water vapor, and microbial content (typically less than 0.1 CFU/cu. ft.)

## **L. Equipment Qualification/Validation (see [Chapter 13](#))**

### **1. Container Preparation**

Parenteral drug containers are typically fabricated from glass (bottles, vials, syringes, or ampules) or plastic (bottles, bags, vials, or syringes). Regardless of the nature of the container, contaminating substances such as paper fibers, glass fragments, viable microbes, and pyrogenic materials must be eliminated from the containers before they are used in the filling operation.

The suitability of the design and utility services is established during the IQ and OQ phases of qualification discussed earlier in this chapter. Important criteria for a typical washer include the following:



Water: quality, temperature, pressure, and flow rate  
Steam: quality and pressure  
Compressed air: quality and pressure

The duration of the prewash, washing, final rinse, and flush cycles must be established during validation and maintained within suitably narrow ranges to ensure repeatability.

One practical approach to validating the cleaning process is to establish a known level of challenge contaminant, which is applied or “spiked” into numbered or otherwise identified containers, which then undergo a typical cleaning cycle. Typical contaminants include visible and subvisible particulate matter and chemical, microbiological, and pyrogen challenges.

After the wash cycle, the spiked container is evaluated by suitable testing to determine the amount of residual contaminant. The “before” and “after” numbers can be compared to establish an efficiency number based on the original level of contaminant.

Bioburden loading levels were determined by a membrane filtration procedure prior to washing and also after the spiking to confirm that the desired challenge level was achieved. Following the cleaning cycle, the same procedure was used to evaluate residual bioburden. To recover the residual contaminants, sterile peptone water USP is used to rinse the entire inner surface of each vial. Results are reported as CFU per vial.

Pyroburden was determined by validated limulus amoebocyte lysate (LAL) techniques both before and after treatment in the washer to confirm pre-existing and challenge levels. It is expected that pretreatment pyroburdens will be low, and removal of a known challenge of pyrogen in the cleaning will be low. Removal of a known challenge of pyrogen in the cleaning procedure provides assurance that subsequent dry-heat depyrogenation will eliminate any pre-existing contamination.

## 2. Closure Preparation

The most common type of primary closure used in conjunction with glass containers for parenteral drugs is the elastomeric closure. As with the container itself, the closure must be sterile, pyrogen-free, and free from contaminants that could adulterate the drug substance, because the closure is likely to be in direct contact with the drug at some time during the storage, handling, or use of the dosage unit.

A number of undesirable substances could be present on the surface or sorbed into the matrix of the closures, but the predominant contaminants are particles of the closure matrix itself, other rubber compounds, metallic particles, micro-organisms, endotoxins, and template lubricants, which are usually organic in nature. In addition, various extractable substances used in the formulation of

the elastomeric closure can present problems. These extractable substances include such activators as ZnO, MgO, and stearic acid; such curing agents as sulfur and phenolic compounds; such accelerators as amines and thiazoles; and such antidegradants as dithiocarbamates and various ketones and aldehydes.

Closure sterilization, following the cleaning cycle, is typically done by autoclaving with saturated steam. The temperatures achieved in such treatments are not sufficient to eliminate significant endotoxin contamination.

The validation of any cleaning procedure must therefore include testing for residual endotoxin, particulate matter, and any adventitious contaminant determined during the pretreatment examination. Achieving sterility during the cleaning cycle is not an absolute requirement; however, the bioburden remaining should not present a significant challenge to the subsequent sterilization process and should be considered in the development of those treatments.

Many manufacturers use equipment that combines the steps of washing, siliconization, and sterilization in a continuous operation. Such a treatment is desirable because it minimizes the time the closures are held in a wet condition. If sterilization does not follow the washing step immediately, the components must be thoroughly dried to eliminate the likelihood of microbial growth and/or formation of pyrogens. Closures should be handled in such a manner as to minimize the potential for contamination from the cleaning operation through the filling and sealing steps.

### 3. Filling Equipment

Validation protocols for filling accuracy should specify the number and duration of filling runs for each size and fill configuration, the filling rates, and the limits for filling variability considered acceptable to the manufacturer. The purpose of the validation work is to determine a filling configuration (i.e., line speed, fill quantity, and container size combination) that will provide the optimum line speed while maintaining acceptable filling variability. Generally, the higher the filling rate, the poorer the filling accuracy.

### 4. Sealing/Capping Equipment

Adequacy of the container-closure system is determined through stability studies during the development work and is not the subject of the validation project for the equipment. It is the objective of this phase to demonstrate that the sealing/capping equipment will consistently apply the overcap in such a manner that the integrity of the unit is ensured.

Container-closure integrity studies also can be conducted to validate the sealing efficiency of the capping equipment.

## 5. Lyophilization (see [Chapter 9](#))

During the OQ the following specialized checks should be conducted:

- Maximum chamber vacuum under no load
- Chamber leak rates under vacuum and pressure
- Shelf temperature control (i.e., temperature variation)
- Vacuum pumping rate
- Chamber heating and cooling rates under no-load conditions to establish a reference point for future study
- Condenser cooling rate
- Refrigerant integrity test to verify that coolant does not leak into the chamber
- Condenser drying rate to establish the maximum drying rate of which the unit is capable
- Stoppering mechanism functionality to verify that the mechanism will properly insert the vial stoppers over the entire range of vials to be used

In addition to the product specifications other attributes peculiar to lyophilized products should be verified. These may include: uniformity of cake, cake color, cake height, reconstitution time, moisture content (if not a product specification), and short-term (accelerated) and long-term stability.

Validation of the lyophilizer cleaning and sterilization processes should be accomplished. Particular care should be taken to verify that there is no back-migration of contaminants, whether from adjuvant fluids integral to the equipment or by cross-contamination from previous product. Typically, an overkill approach using a sufficient number of thermocouples and biological indicators is the method of choice. Finally, fill testing to verify the adequacy of the sterilization procedure and the aseptic manipulations involved with product filling, transfers, and lyophilization needs to be performed.

## M. Environmental Qualification

The effort spent in qualification and validation of the utilities, equipment, and processes that make up a sterile product manufacturing operation is wasted unless the manufacturing environment is maintained under control at all times during production.

The environment of an aseptic filling operation must be monitored and controlled. Environmental control begins with valid cleaning and sanitization procedures, then proceeds with adequacy of certified HEPA filtration and clean room procedures by personnel within the clean room, and is verified by environmental monitoring techniques. Such techniques include nonviable particulate

monitoring of the air (electronic particle counters), surface sampling of equipment and personnel (Rodac plates primarily; sometimes swab samples), and airborne viable particulate monitoring (fallout or settling plates, and quantitative air samplers such as rotary centrifugal samplers or slit-to-air samplers).

## **APPENDIX I: EXAMPLE PROTOCOL FOR VALIDATION OF THE STERILIZATION PROCESS IN A STEAM AUTOCLAVE**

Reference No. \_\_\_\_\_

Date \_\_\_\_\_

I. Purpose:

To provide the method to be used for the validation of the sterilizing process using an autoclave containing \_\_\_\_\_.

II. Scope:

This procedure applies to all steam autoclaves used to process filling equipment, package components, or final containers. The procedures will be implemented under the following conditions:

- A. The validation of sterilization processes using saturated steam as the sterilant.
- B. Prior to production use of a new autoclave.
- C. A change in load design or weight that would result in a load that is more difficult to sterilize.

III. References:

- A. USP.
- B. CFR title 21, subchapter E.

IV. Responsibility:

Process validation department.

V. Autoclave identification:

Make \_\_\_\_\_  
Location \_\_\_\_\_  
Tag no. \_\_\_\_\_  
Mfg. serial no. \_\_\_\_\_

VI. Load identification:

- A. Description.
- B. Weight of load \_\_\_\_\_

VII. Cycle parameters:

No. of pre-vac pulses \_\_\_\_\_

Sterilization:

Temp set point \_\_\_\_\_  
Temp range \_\_\_\_\_

Exposure time \_\_\_\_\_

Dry time \_\_\_\_\_

VIII. Equipment and materials:

- A. Recording potentiometer.
- B. Thermocouples and lead wire harness.
- C. Compression fitting for autoclave access port.
- D. *B. stearothermophilus* biological indicators \_\_\_\_\_

IX. Procedure:

- A. Place 10 thermocouples in the load at the 10 slow-to-heat points, as determined previously on prot. no. \_\_\_\_\_ (penetration TC).
- B. Place thermocouples exterior and near to the penetration TC and exposed to the chamber steam (distribution TC).
- C. Place one BI at each of the slow-to-heat penetration locations.
- D. Load autoclave.
- E. Extend TC out of autoclave and attach to recording potentiometer.
- F. Position one TC by controller recorder sensor.
- G. Close autoclave door.
- H. Perform function check of TC. Replace any defectives.
- I. Replace autoclave recording chart with a new one, if appropriate.
- J. Check to make sure cycle parameters are set.
- K. Set potentiometer for a \_\_\_\_-min scan cycle.
- L. Initiate sterilization cycle and potentiometer cycle at the same time.  
Time \_\_\_\_\_
- M. Allow cycle to continue until it is complete. Record the following:  
Time process start \_\_\_\_\_  
Time sterilization cycle on \_\_\_\_\_  
Sensor TC read \_\_\_\_\_  
Time sterilization cycle complete \_\_\_\_\_  
Chamber pressure at cycle initiation \_\_\_\_\_
- N. Time cycle complete \_\_\_\_\_
- O. Collect all potentiometer, control, and computer control records and place with this protocol.
- P. Have computer graph results and calculate  $F_0$  delivery.
- Q. After load has cooled, remove BI and have tested.
- R. Incubate BIs in incubator at 55°C for 48–56 hr.  
Date on \_\_\_\_\_  
Date off \_\_\_\_\_
- S. Similarly, place an untreated control into incubator as in (R) above.  
Date on \_\_\_\_\_  
Date positive \_\_\_\_\_  
Read by \_\_\_\_\_  
Date \_\_\_\_\_

X. Results:

BI

\_\_\_\_\_  
Read by \_\_\_\_\_  
Date \_\_\_\_\_  
 $F_0$  delivery  
high \_\_\_\_\_  
low \_\_\_\_\_

XI. Signatures of operators conducting study:

\_\_\_\_\_ date \_\_\_\_\_  
\_\_\_\_\_ date \_\_\_\_\_  
\_\_\_\_\_ date \_\_\_\_\_  
\_\_\_\_\_ date \_\_\_\_\_

XII. Protocol reviewed by: \_\_\_\_\_ date \_\_\_\_\_

XIII. Conclusions:

## APPENDIX II: MEDIUM CONSIDERATIONS IN PRODUCT SIMULATION TESTS

The efficacy of the product simulation test rests on the ability of the culture medium—manufacture, sterilization, and incubation—to grow contaminating bacteria. The following outline is from the Parenteral Drug Association, Technical Monograph No. 2, *Validation of Aseptic Filling for Solution Drug Products* concerning growth media, which should be consulted for additional details.

### 5.2.1. Medium Considerations for Use in Product Simulation Tests

#### (a) Type of Medium

A number of general microbiological growth media are available and may be used in a process simulation program. In general, when selecting a medium for use, the following considerations should be made:

*Selectivity*—The medium should have low selectivity; i.e., it should support the growth of a broad spectrum of organisms including fungi and yeasts.

*Clarity*—The medium should be clear to allow for ease in observing turbidity.

*Filterability*—Medium should not contain agar or high levels of suspended solids when a filtration process is used.

Soybean casein digest (SCD)\* is currently one of the most fre-

---

\*Use only if testing for anaerobiosis of thioglycollate medium.

quently used media, due to its low selectivity and relatively low cost; however, a partial listing of acceptable media would also include the following:

- Tryptone glucose yeast extract (TGYE)\*
- Brain heart infusion (BHI)\*
- Alternate (NIH)\* thioglycollate (if an anaerobic growth medium is desired)

(b) Medium Concentration

The medium of manufacturer's recommended concentration should be used when preparing media for process simulation tests unless other concentrations can be shown empirically to be equivalent.

(c) Medium Utilization

In conducting process simulation tests, there are two basic alternative techniques available:

1. Use unsterilized medium and filter the medium through the normal sterilizing membrane hooked directly to the filling equipment. The media may be prefiltered to reduce bioburden and increase filtration efficiency.
2. Presterilize the medium in a separate operation. After verification of medium sterility (such as examining the bulk medium for absence of growth), use the medium in the process simulation test. For the test, pass the sterilized medium through normal processing equipment.

(d) Medium Sterilization

Medium for use in a process simulation test can be rendered sterile using either moist heat (autoclaving) or filtration. The method chosen depends on the availability of suitable equipment and the information desired from the study.

1. Sterilization with Steam

When using this approach it is recommended that

- The medium should be solubilized and dispensed into vessels with suitable closures to allow for filtered gas exchange and for subsequent dispensing at the filling line. The vessel should, if possible, be identical to regular production equipment.
- The medium should be exposed to steam under pressure in a validated sterilization cycle to achieve at least a  $10^{-6}$  probability of survival of organisms within the medium.
- Medium should be cooled slowly to prevent excessive boiling.

---

\*Use only if testing for anaerobiosis of thioglycollate medium.

- Medium is ready for use immediately upon cooling. It should be inspected for clarity prior to use.
2. Sterilization by Filtration
- When using this approach it is recommended that:
- Medium be solubilized at an elevated temperature (50°C) to facilitate dissolution of the solids.
  - Filtration be conducted under normal production conditions using a sterilizing grade of filter with adequate prefiltration to increase final filter throughput and life.
  - Medium may be stored in bulk vessels following filtration to ensure that adequate aseptic technique was used.

### 5.2.3. Media Incubation Parameters

(a) Technique

The filled container with medium should be gently rotated immediately prior to incubation so that all surfaces, including the closure (if any), are wetted by the medium. The container should be incubated in an upright position with the closure uppermost. This posture minimizes the migration of closure ingredients which might affect the growth promoting characteristics of the medium.

(b) Time

Media, in the sealed container as delivered from the production line, should be incubated for a minimum of 14 days.

(c) Temperature

Process simulation test containers should be incubated at suitable incubation parameters.

The temperature should be monitored throughout the test period and should be maintained within the specified range for the test period. Deviations from the specified range should be evaluated and countered with appropriate action.

(d) Positive Controls

These should be incubated under the identical incubation conditions as the test containers.

### 5.2.4. Test Controls

The growth-promoting ability of the medium in the final filled containers should be demonstrated using filled control containers challenged with low levels of microorganisms.

(a) Micro-organisms

Compendial micro-organisms—the micro-organisms referenced in the USP for sterility test growth promotion tests—are suitable for use as controls. These include the following:

- *Bacillus subtilis* (spores) ATCC #6633 or *Micrococcus lutea* ATCC #9341



- *Candida albicans* ATCC #10231
- *Bacteroides vulgatus* ATCC #8482\* or *Clostridium sporogenes* (spores) ATCC #11437\*

As an alternative to compendial microorganisms, isolates frequently encountered in the manufacturing environment may be used to challenge the medium.

A combination of compendial organisms and indigenous organisms may be used as controls. In all cases, however, microorganisms used in growth promotion testing should include both bacterial and fungal species.

(b) Challenge Parameters

Challenge levels not to exceed 100 cells per container should be used in an attempt to simulate low-level contamination.

Dilutions of actively growing or frozen stock cultures may be used.

A viable count via a pour plate or spread plate should be obtained for the final dilution of each micro-organism to verify the challenge level.

Growth promotion studies should be carried out in duplicate for each type of micro-organism and each type of container system.

Incubation parameters should be identical to those of the test medium.

(c) Interpretation of Results

Medium is acceptable if growth is observed in at least one of the two test containers for all of the challenge micro-organisms.

If no growth is observed in both of the challenged containers, one repeat test may be conducted to rule out laboratory error. On the repeat test, both containers must support growth.

## REFERENCES

1. Mascoli, C. C. Should end-product sterility testing continue? *Med Dev Diag Ind* 3: 8–9 (1981).
2. Bowman, F. W. The sterility testing of pharmaceuticals. *J Pharm Sci* 58:1301–1308 (1969).
3. Ernst, R. R., West, K. L., Doyle, J. E. Problem areas in sterility testing. *Bull Parenter Drug Assoc* 23:29–39 (1969).
4. Akers, M. J. In: *Parenteral Quality Control: Sterility, Pyrogen, Particulate Matter and Package Integrity Testing*, 2d edition. New York: Marcel Dekker, pp. 1–4 (1994).
5. Brewer, J. H. In: G. L. Redish, ed. *Antiseptics, Disinfectants, Fungicides, and Sterilization*. 2nd ed. Philadelphia: Lea & Febiger, pp. 160–161 (1957).

6. Food and Drug Administration. *Guideline on General Principles of Process Validation*. Rockville, MD: FDA (1984).
7. *Validation of Steam Sterilization Cycles*. technical monograph no. 1. Parenteral Drug Association (1978).
8. Pflug, I. J., Holcomb, R. G. Principles of thermal destruction of microorganisms. In: S. S. Block, ed. *Disinfection, Sterilization and Preservation*. 4th ed. Philadelphia: Lea & Febiger, pp. 85–131 (1991).
9. Moats, W. A. Kinetics of thermal death of bacteria. *J Bacteriol* 105:165–171 (1971).
10. Stumbo, C. R. *Thermobacteriology in Food Processing*. New York: Academic (1965).
11. Han, Y. W. Death rates of bacterial spores: Nonlinear survivor curves. *Can J Microbio* 21:1464–1467 (1975).
12. Han, Y. W., Zhang, H. I., Krochta, J. M. Death rates of bacterial spores: Mathematical models. *Can J Microbio* 22:295–300 (1976).
13. *Validation of Dry Heat Processes Used for Sterilization and Depyrogenation*. technical report no. 3. Parenteral Drug Association (1981).
14. Pflug, I. J. Sterilization: Science, not art. *Med Dev Diag Ind* 8–9 (March 1981).
15. Barry, I. R. Process validation: A U.S. viewpoint. *Mfg Chem* 34–35 (Jan. 1983).
16. Witonsky, R. J. A new tool for the validation of the sterilization of parenterals. *Bull Parenter Drug Assoc* 31:274–281 (1977).
17. Bunn, J. L., Sykes, I. K. A chemical indicator for the rapid measurement of  $F_0$  values. *J Appl Bacteriol* 51:143–174 (1981).
18. Caputo, R. A., Mascoli, C. C. The design and use of biological indicators for sterilization-cycle validation. *Med Dev Diag Ind* 23 (Aug. 1980).
19. Reich, R. R., Whitbourne, J. E., McDaniel, A. W. Effect of storage conditions on the performance of *Bacillus stearothermophilus* biological indicators. *J Parenter Drug Assoc* 33:228 (1979).
20. Pflug, I. J. Monitoring the sterilization process. In: *Syllabus for Introductory Course in the Microbiology and Engineering of Sterilization Processes*. 2nd ed. Philadelphia: Parenteral Drug Association, pp. 19.2–19.4 (1978).
21. Simmons, P. L. Validation of dry heat sterilizers. *Pharm Eng* 38 (May–July 1981).
22. Simmons, P. L. *Hot Air and Continuous Sterilization*. Washington, D.C.: Pharmaceutical Manufacturers Association, p. 27 (1978).
23. Tsuji, K., Harrison, S. J. Dry-heat destruction of lipopolysaccharide: Dry heat destruction kinetics. *Appl Environ Microbio* 36:710–714 (1978).
24. Akers, M. J., Avis, K. E., Thompson, B. Validation studies of the Fostoria infrared tunnel sterilizer. *J Parenter Drug Assoc* 34:330–347 (1980).
25. Wegel, S. Short time sterilization of glass materials under ultraclean conditions. *Bull Parenter Drug Assoc* 23:122–135 (1974).
26. Akers, M. J., Ketron, K., Thompson, B. F value requirements for the destruction of endotoxin in the validation of dry heat sterilization/depyrogenation cycles. *J Parenter Drug Assoc* 36:23–27 (1982).
27. Avis, K. E., Jewell, R. C., Ludwig, J. D. Studies on the thermal destruction of *Escherichia coli* endotoxin. *J Parenter Drug Assoc* 41:49 (1987).

28. Ludwig, J. D., Avis, K. E. Validation of a heating cell for precisely controlled studies on the thermal destruction of endotoxin in glass. *J Parenter Drug Assoc* 42:9 (1988).
29. Ludwig, J. D., Avis, K. E. Recovery of endotoxin preparations from the surface of glass capillary tubes. *J Parenter Drug Assoc* 43:276 (1989).
30. Ludwig, J. D., Avis, K. E. Dry heat inactivation of endotoxin on the surface of glass. *J Parenter Drug Assoc* 44:4 (1990).
31. Robertson, J. H., Townsend, M. W., Allen, P. M., et al. Validation of ethylene oxide sterilization cycles. *Bull Parenter Drug Assoc* 31:265–273 (1977).
32. Valenti, L. A validation program for ETO sterilization. *Med Dev Diag Ind* 1:15 (1979).
33. Halleck, F. E. Principles for the validation of ethylene oxide sterilization cycles. *Med Dev Diag Ind* 2:27 (1980).
34. Simmons, P. L. ETO sterilizer validation. *Pharm Eng* 1:13 (1981).
35. Caputo, R. A., Rohn, K. J., Macoli, C. C. Biological validation of an ethylene oxide sterilization process. *Dev Indus Microbio* 22:357–362 (1981).
36. Edwards, L. M., Childers, R. W. Hydrogen peroxide vapor sterilization: Applications in the production environment. In: M. J. Groves and R. Murty, eds. *Aseptic Pharmaceutical Manufacturing II: Applications for the 1990s*. Buffalo Grove, IL: Interpharm Press, pp. 415–466 (1995).
37. Silverman, G. J. Sterilization by ionizing radiation. In: S. S. Block, ed. *Disinfection, Sterilization and Preservation*. 4th ed. Philadelphia: Lea & Febiger, pp. 566–579 (1991).
38. ISO 11137:1995. Sterilization of health care products—Requirements for validation and routine control—Radiation sterilization. Arlington, VA: Association for the Advancement of Medical Instrumentation (AAMI) (2000).
39. Health Industry Manufacturers Association. Medical Device Sterilization Monographs, Sterilization Cycle Development. report no. 78-4.2 (1978).
40. Shoemaker, W. In: W. Shoemaker, ed. *What the Filter Man Needs to Know About Filtration*, AIChE Symposium Series, no. 171, vol. 73. New York: AIChE, pp. 1–3 (1977).
41. Meltzer, T. H., Jornitz, M. W. *Filtration in the Biopharmaceutical Industry*. New York: Marcel Dekker (1998).
42. *Fed Reg* 41 (106):2214 (June 1, 1976).
43. Food and Drug Administration. *Guidelines on Sterile Drug Products Produced by Aseptic Processing*. Rockville, MD: FDA (1987).
44. Wallhausser, K. H. *J Parenter Drug Assoc* 33(3):156 (1979).
45. Lukaszewicz, R. C., Meltzer, T. H. *J Parenter Drug Assoc* 33(5):246 (1979).
46. Osumi, M., Yamada, N., Toya, M. Bacterial retention mechanisms of membrane filters. *J Pharm Sci Tech* 50:30–34 (1996).
47. Calvo, J. I., Hernandez, A., Pradanos, P., Martinez, L., Bowen, W. R. Pore size distributions in microporous membranes. *J Colloid Interf Sci* 176:467–478 (1995).
48. Thomas, A. J., Durrheim, H. H., Alport, M. J. Validation of filter integrity by measurement of the pore-distribution function. *Pharm Tech* 16:32–43 (1992).
49. Lukaszewicz, R. C., Tanny, G. B., Meltzer, T. H. *Pharm Tech* 2(11):77 (1978).

50. Howard, G. Jr., Duberstein, R. *J Parenter Drug Assoc* 34(2):95 (1980).
51. *Sterilizing Filtration of Liquids*. technical report no. 26. Parenteral Drug Association (1998).
52. MacDonald, W. D., Pelletier, C. A., Gasper, D. L. Practical methods for the microbial validation of sterilizing-grade filters used in aseptic processing. *J Parenter Sci Tech* 43:268–270 (1989).
53. Lukaszewicz, R. C., Meltzer, T. H. *J Parenter Drug Assoc* 33(4):187 (1979).
54. Jacobs, S. *Filtration and Separation* 9(5):525 (1972).
55. JorNIK, M. W., Agalloco, J. P., Akers, J. E., Madsen, Jr., R. E., and Meltzer, T. H. *PDA J. Pharm Sci Tech* 56(1) 4–10, (2002).
56. Johnston, P. R., Lukaszewicz, R. C., Meltzer, T. H. *J Parenter Sci Tech* 34(10):36 (1981).
57. Meltzer, T. H., Meyers, T. R. *Bull Parenter Drug Assoc* 25(4):165 (1971).
58. Olson, W. P., Martinez, E. D., Kern, C. R. *J Parenter Sci Tech* 35(5):215 (1981).
59. American Society for Testing and Materials. Standard Test Method for Pore Size Characteristics of Membrane Filters for Use with Aerospace Fluids. ASTM F316-80, part 25. Philadelphia: pp. 872–878 (1981).
60. Reti, A. R. *Bull Parenter Drug Assoc* 31(4):187 (1977).
61. Schroeder, H. G., DeLuca, P. P. *Pharm Tech* 4:80 (1980).
62. Olson, W. P., Briggs, R. O., Garanchon, C. M., et al. *J Parenter Drug Assoc* 34(4): 254 (1980).
63. *Sterilizing Filtration of Liquids*. technical report no. 26. *PDA J Pharm Sci Tech* 52:SI (1998).
64. Reti, A. R., Leahy, T. J. *J Parenter Drug Assoc* 33(5):257 (1979).
65. Leahy, T. J., Sullivan, M. J. *Pharm Tech* 2(11):65 (1978).
66. Price, J. M., Pauli, W. A. *Bull Parenter Drug Assoc* 30(1):45 (1976).
67. Stone, T. E., Goel, V., Leszczak, J. Methodology for analysis of filter extractables: A model stream approach. *Pharm Tech* 18:116 (1994).
68. Johnston, P. R., Meltzer, T. H. *Pharm Tech* 3(11):66 (1979).
69. Meltzer, T. H., JorNitz, M. W. *Filtration in the Biopharmaceutical Industry*. New York: Marcel Dekker (1998).
70. Reif, O. W., Solkner, P., Rupp, J. Analysis and evaluation of filter cartridge extractables for validation in pharmaceutical downstream processing. *J Pharm Sci Tech* 50:399–410 (1996).
71. Stone, T. E., Goel, V., Leszczak, J. Methodology for analysis of filter extractables: A model stream approach. *Pharm Tech* 18:116 (1994).
72. Pall, D. B., Kirnbauer, E. A. Bacterial removal prediction in membrane filters. Proceedings of 52nd Colloid and Surface Science Symposium, University of Tennessee, Knoxville, June 12, 1980.
73. *Validation of Aseptic Filling for Solution Drug Products*. technical monograph no. 2. Philadelphia: Parenteral Drug Association, pp. 16–21 (1980).
74. U.S. Food and Drug Administration. proposed revised *Guidelines on Sterile Drug Products Produced by Aseptic Processing*. Rockville, MD: FDA (Nov. 30, 1998).
75. Carleton, F. J., Agalloco, J. P. *Validation of Aseptic Pharmaceutical Processes*. New York: Marcel Dekker (1986).
76. Hofmann, K. L. Sterile products validation. In: I. R. Berry, R. A. Nash, eds. *Phar-*

- maceutical Process Validation*. 2nd ed. New York: Marcel Dekker, pp. 89–166 (1993).
77. Cloud, P. A. *Pharmaceutical Equipment Validation—The Ultimate Qualification Guidebook*. Englewood, CO: Interpharm Press (1998).
  78. DeSain, C., Sutton, C. Facility qualification studies. *Biopharm* 38–41 (Jan. 1998).
  79. Collentro, W. V. *Pharmaceutical Water—System Design, Operation, and Validation*. Englewood, CO: Interpharm Press (1998).
  80. Anderson, N. R. Container cleaning and sterilization. In: W. P. Olson, M. J. Groves, eds. *Aseptic Pharmaceutical Processing*. Prairie View, IL: Interpharm Press (1987).

# 5

## Validation of Solid Dosage Forms

**Jeffrey S. Rudolph**

*St. Augustine, Florida, U.S.A.*

**Robert J. Sepelyak**

*AstraZeneca Pharmaceuticals LP, Wilmington, Delaware, U.S.A.*

### I. INTRODUCTION

In this chapter, emphasis will be placed on the validation of solid dosage forms, from the early stages of product development through pilot scale-up and the commercial manufacturing process. The objective is to present an overview and to discuss aspects of validation in terms of pharmaceutical unit operations; that is, those individual technical operations that comprise the various steps involved in product design and evaluation. The focus of the discussion will be on tablets, but consideration will also be given to hard gelatin capsules. The concept of process validation from its beginnings in the early 1970s through the regulatory aspects associated with current good manufacturing practice (CGMP) regulations and the application thereof to various analytical, quality assurance, pilot plant, production, and sterile produce considerations will be discussed elsewhere in this book [1,2].

Although the original focus of validation was directed toward prescription drugs, the FDA Modernization Act of 1997 expanded the agency's authority to inspect establishments manufacturing over-the-counter (OTC) drugs to ensure compliance with CGMP, thus establishing documented evidence that specific processes or equipment will consistently, and with a high degree of assurance, produce a product that meets predetermined specifications and quality attributes [3].

All pharmaceutical scientists, whether in development, quality assurance, production, or regulatory affairs, are familiar with the axiom that quality is not

tested into a product but rather is built in. This is an important concept, since it serves to support the underlying definition of validation, which is a systematic approach to identifying, measuring, evaluating, documenting, and re-evaluating a series of critical steps in the manufacturing process that require control to ensure a reproducible final product. Dr. Chao [4] has enumerated four key elements that form the basis of a prospective process validation program.

1. Definition of the desirable attributes of the drug product or components thereof as well as those characteristics that are not desired
2. Establishment of limitations or constraints for these attributes
3. Determination of the controls or testing parameters that will be measured or tested
4. Initiation of studies to establish control or boundary limits for those key attributes that influence the product, process, quality, and performance

These criteria represent a logical progression of activities encompassing the development of a pharmaceutical product.

There are several important reasons for validating a product and/or process. First, manufacturers are required by law to conform to CGMP regulations. In the early 1990s, the concept of preapproval inspection (PAI) was born and had as one of its basic tenets the assurance that approved validation protocols and schedules were being generated and that comprehensive development, scale-up, and biobatch and commercial batch validation data were required in order to achieve a successful regulatory PAI audit [5–9]. Second, good business dictates that a manufacturer avoid the possibility of rejected or recalled batches. Third, validation helps to ensure product uniformity, reproducibility, and quality [10–12].

Most discussions of product and process validation that have been published [13–15] or that have been the subject of presentations at meetings have concentrated on validation associated with the full-scale manufacture of pharmaceutical processes and how equipment processing variables affect the overall quality of the finished product. Although this is certainly an important aspect of product validation, validation of numerous earlier aspects of development are critical to the subsequent phases of the process.

Without proper characterization, specification, and control of these earlier development steps, the foundation will be weak and will not support the evolving product when it is challenged during the formal validation of pilot and production batches.

## **II. VALIDATION OF RAW MATERIALS**

The validation process of a solid dosage form begins with a validation of the raw materials, both active pharmaceutical ingredients (APIs) and excipients [16–19].

Variation in raw materials is one of the major causes of product variation or deviation from specification. The API may represent the most uncontrollable component in the complete product/process validation scheme, as key physical properties such as morphology and particle size/surface area may not be completely defined this early in the sequence. Often times the synthesis of the new API (drug substance) is not finalized, and changes occur during the development of the compound.

The preformulation program initiated during the early exploratory phase of product development is rarely considered part of validation, but it represents one of the more critical steps in the development cycle. Chemical characteristics such as drug impurities and impurity levels can affect the stability of the product. Physical properties such as drug morphology, solubility, and particle size/surface area are important in assessing drug availability. The particle size, shape, and density of the drug can affect material flow and blend uniformity. The hygroscopic nature of the drug can be important in both the handling the material and the reproducibility of the manufacturing process [20].

For example, a water-insoluble drug is usually milled or micronized in order to achieve rapid dissolution and *in vitro* availability [14]. Since particle size is inversely related to surface area, large surface areas (0.5–5 m<sup>2</sup>/g) are created during a particle reduction process. Particle size is directly interrelated to several key processing variables. Several of the most significant are flow, blend uniformity, granulation solution/binder uptake, compressibility, and lubricant efficiency [21]. In order to achieve a uniform blend of active ingredient with other formula components, either for subsequent wet granulation or direct compression processing, it is critical that the active ingredient be compatible with the other ingredients in terms of particle size, density, and shape in order to permit a random distribution of ingredients within the blend prior to compression. If the milling or micronizing process is not controlled and properly validated so as to achieve a reproducible particle size distribution, irregularities in blend distribution will result in content uniformity problems of the final dosage form [22].

Another manufacturing characteristic that may be affected negatively by not validating the active ingredient particle size distribution/surface area is the volume of granulating solution or binder needed to produce a properly agglomerated mass. A greater volume of granulating agent will be needed to wet-mass a powder bed comprising finely divided particles than is needed for coarser particles of the same substance. If the particle size/surface area ratio is not controlled and a specific amount of granulating solution is not stated in the product manufacturing directions, then in some cases the wet mass will be over-wet, resulting in erratic drying properties (case-hardening, insufficient dried product), or in contrast, it will be too dry and will not form proper granules, resulting in poor granulation flow, poor tablet compressibility, and content uniformity problems with the final dosage form.



The certification/validation of excipients used in solid oral dosage forms is also extremely important [23]. Excipients can represent less than 1% of a tablet formula or as much as 99%. It is no less important to validate the critical characteristics of the 1% material than of an excipient used in larger quantities. Factors to be aware of are (1) the grade and source of the excipients, (2) particle size and shape characteristics, and (3) lot-to-lot variability.

Three specific examples illustrate this point.

1. Microcrystalline cellulose is widely used in solid dosage forms as a diluent. It is manufactured in different grades and by different companies. There can be significant differences in the chemical composition, crystallinity, and particle size/size distribution between different microcrystalline cellulose lots [24]. Besides differences between manufacturers, differences can be seen with the same company using different manufacturing sites, raw materials, and/or manufacturing processes [24–27]. Differences in the particle size/size distribution of microcrystalline cellulose can affect the wet granulation step and/or blend uniformity of a tablet formulation [28]. With direct compression formulations, differences in particle size distribution between lots can result in (1) the initial mix not actually being uniform when using the validated processing parameters, or (2) materials segregating during compression. A smaller particle size will require additional binder solution to granulate the materials due to the greater surface area of the microcrystalline cellulose. This could result in granules having greater strength, which could decrease the tablet dissolution rate. The dissolution rate of prednisone was shown to vary due to the particle size and chemical composition of microcrystalline cellulose [29].
2. Magnesium stearate is used as a lubricant to reduce friction when removing the solid dosage form from its molding process. It is well known that the action of magnesium stearate is highly dependent on its particle size and its ability to delaminate its “deck of cards” configuration when stress is applied, thus creating a slipping action that relieves the applied stress [30]. It is also well known that when magnesium stearate is used in excess, the disintegration and dissolution characteristics of the final tablet or capsule are usually hindered as a result of a hydrophobic coating of the formula components. This coating action can also be achieved by using a smaller particle size or greater surface area lubricant. The smaller particle size lubricant more efficiently coats the surface of the particles, thus creating more hydrophobicity and subsequent drug-release problems. Lot-to-lot variability and differences between manufacturers have been shown to affect tab-

let properties (e.g., tablet hardness) and performance (e.g., dissolution) [31–34]. It is critical to validate the particle size/surface area characteristics of a supplier's grade of magnesium stearate to ensure that there is relatively good assurance that the stearate is uniform lot after lot. Also, when an alternate source of stearate is sought, it is critical to check the particle size/surface area and shape characteristics to ensure that these parameters do not vary significantly from the primary source material. If these criteria are different, a more in-depth study, possibly using an instrumented tablet machine, would be appropriate to ensure that alternate source stearate does not cause compression or ejection problems. Dissolution testing would also be conducted as a companion test, again to ensure that the new stearate did not create in vitro drug release problems.

3. The importance of validating a raw material can also be illustrated in the case of dyes used to impart a color to a tablet. Consider the use of an aluminum lake dye that is dry-blended into a direct compression tablet formulation. In order to achieve an even color distribution, the colorant should be added using a geometric addition or preblend approach. Unless the dye is available as a finely divided, large surface area material that is free from agglomerates, the resulting tablets will be mottled and have areas of high dye concentration, which may yield a speckled tablet appearance. The validation of colorant raw materials using such techniques as particle size analysis, surface area measurements, and Hegman gauge testing is critical to ensure that all lots of dye material received will repeatedly perform in a successful manner when incorporated into pharmaceutical dosage forms.

A comprehensive program for establishing validation and control procedures for raw materials is critical if one is to achieve a product that meets all of the final product criteria batch after batch.

Variations in raw materials constitute one of the major sources of problems confronting the pharmaceutical development scientist, production supervisor, or quality control chemist. Variations in materials occur among different suppliers of the same product, depending on the method of transportation chosen, the exposure of materials to undesirable conditions (heat, humidity, oxygen, light), the reliability of the supplier, and the individual supplier's conformance to regulatory requirements in terms of facilities, personnel, operating procedures, and controls. In addition to the important physical characteristics of particle size, surface area, and the like mentioned previously, the manufacturer should check the supplier's assay procedure as part of its own validation program. Other chemical characteristics, such as water content, residue on ignition, and heavy metals, should also be monitored.

The steps involved in the validation of a raw material or excipient follow those cited in the CGMPs and in the formal written documentation of those procedures and methods used.

1. Each raw material should be validated by performing checks on several batches (at least three) from the primary supplier as well as the alternate supplier. The batches chosen should be selected to represent the range of acceptable specifications, both high and low.
2. Depending on the susceptibility of the raw material to aging, physical, chemical, and/or microbiological stability should be assessed. This is especially true for liquid or semisolid ingredients, in which interaction with the container or permeability of the container to air and moisture could have a detrimental effect on the raw material.
3. Once the samples of raw materials have been selected as having fallen into an established, acceptable range of specifications and stability, it should be used to manufacture a batch of the final dosage form. It may be appropriate to manufacture several lots of final product with raw material at the low and high ends of the specification limit. Such testing would be especially useful when it is known that the product may be sensitive to small changes in the characteristics of the excipients or active ingredient.
4. The final step of raw material validation should involve an on-site inspection of the supplier to review the vendor's manufacturing operations and control procedures. The reliability of each vendor and how well each conforms to regulatory requirements must also be determined.

### **III. ANALYTICAL METHODS VALIDATION**

The topic of analytical methods validation will be discussed elsewhere in this book in great depth. It is important, however, to enumerate the key elements of this subject at this time. In August 1994, the FDA issued a memo providing direction for the certification of laboratories. Areas discussed in that document included analytical methods validation [35]. Unless a suitable analytical method or series of methods is available to assess the quality and performance of a solid dosage form, the validation program will have limited value. Recently a review article was published focusing mainly on validation criteria and how to validate [36]. The following list of analytical criteria must be assessed prior to beginning any validation program:

1. *Accuracy of method*: The ability of a method to measure the true value of a sample.

2. *Precision of method*: The ability of a method to estimate reproducibility of any given value, but not necessarily the true value.
3. *Specificity*: The ability to accurately measure the analyte in the presence of other components.
4. *In-day/out-of-day variation*: Does the precision and accuracy of the method change when conducted numerous times on the same day and repeated on a subsequent day?
5. *Between-operator variation*: Repeat of the precision and accuracy studies within the same laboratory using the same instrument but different analysts to challenge the reproducibility of the method.
6. *Between-instrument variation*: How will different instruments within the same laboratory run by the same analyst affect the accuracy and precision of the method?
7. *Between-laboratory variation*: Will the precision and accuracy of the method be the same between the development and quality control laboratories?

A collaborative study between various analytical methods chemists who developed the analytical method and the analytical chemists in the quality control laboratory who must routinely run the method will help to ensure the validity and ruggedness of the analytical method. If characteristics of the analytical method are found to be less than optimum or if deficiencies arise during testing, the method should be returned to the originating chemist for re-evaluation.

When a method is being developed, it is important that the analytical chemists developing the methods be cognizant of the laboratory conditions in which the methods will be conducted in a quality control setting.

The methods chemist must be able to make the method work when operating conditions of time, instrument limitations, and other techniques that could "baby" the method are not used. Normal operating conditions in quality control laboratories require a robust method that can be run routinely by different chemists on different instruments in a high throughput mode. In some cases, the method should be automated to take advantage of greater laboratory efficiency. It is the responsibility of the analytical methods development chemist to build these important elements into the methods.

The responsibilities for suitable validated analytical methods, however, do not rest solely in the analytical method development group. Today the analytical function uses new and sophisticated chromatographic and other instrumental techniques that require a high level of technical expertise. It is the responsibility of quality control management to ensure that its staff is adequately trained and its laboratories properly equipped so that new analytical methods can be properly transferred from an analytical methods group to the quality control department. A mutual understanding of each other's responsibilities and limitations is

necessary in order to develop the trust that is required between these two important functions.

Outsourcing the development, validation, and performance of analytical methods in recent years has become a popular means to facilitate movement of product through the development process. A recent industry survey reported that the vast majority (86%) of the companies responding say they outsource analytical methods development to contract laboratories. Twenty-five percent of the responding firms indicated that they “often” or “always” contract out stability testing on development compounds [37]. There are important criteria to follow in working with contract laboratories to ensure that their methods validation procedures yield results that are consistent with those of the client company [38]. This topic will be discussed later in this chapter.

#### **IV. EQUIPMENT/FACILITY VALIDATION**

The product development of a pharmaceutical product has its origins in a systematic approach to formulation, process and manufacture, and the analytical testing that is necessary to monitor quality and reproducibility. Once development scale activities (product development, early toxicology, and clinical evaluation) provide encouragement that the development compound could become a commercial product, a multidisciplinary team is usually formed with product development, production, and engineering staff to plan a life-cycle approach related to the manufacture of the product. For large products, a master plan approach combining elements of project definition, coordination, administration, scheduling, and budgeting is progressed to ensure that all elements of the multi-component plan are efficiently and successfully identified, communicated, progressed, monitored, and delivered.

Process equipment used in the development phase is assessed relative to its suitability for large-scale manufacture. Alternate equipment is identified and evaluated and a final decision rendered. Existing or new equipment to be used to manufacture the new pharmaceutical product must then undergo a comprehensive evaluation called a validation protocol. This protocol can be divided into a number of components, but usually has design qualification, installation qualification, operation qualification, performance qualification, maintenance (calibration, cleaning, and repair) qualification, and closure qualification as integral components [39]. These qualification steps will be discussed in detail in elsewhere in this book. Contrary to popular belief, new equipment and systems sometimes can be more challenging to validate than well-worn older ones. New systems have no use history (operational and maintenance), which can be valuable information that can simplify protocol writing and subsequent validation [40].

Once the full-scale manufacturing equipment and process have been identified, it is important to either ensure that an existing physical facility is available in which the product can be manufactured or determine if a modified or new facility is required. Once these decisions have been made, a validation commissioning document (VCD) is prepared that identifies the shared responsibility and cooperation that must occur among the owner, construction manager, and vendors [41–43]. A commissioning program that is well planned will facilitate the validation process, accelerate start-up, enhance documentation, and ensure that the pharmaceutical product is produced in a GMP-compliant facility. The VCD would usually be prepared by a validation specialist and approved by the facility's project manager. It would be very comprehensive and would include purchase orders, process flow diagrams, operation and maintenance manuals, installation requirements and factory acceptance testing results, heating, ventilation, and air conditioning (HVAC) requirements and test results, calibration procedures, software specifications, and staff training.

A practice has evolved in the qualification of a pharmaceutical facility that is simply to commission certain systems deemed noncritical rather than to validate them. It is important to point out that commissioning should not be a substitute for validation but rather used as a tool to aid in the entire validation process [44].

## **V. DEFINITION AND CONTROL OF PROCESS VARIABLES**

Process validation can be defined as a means of challenging a process during development to determine which variables must be controlled to ensure the consistent production of a product or intermediate. It also provides the means for an ongoing quality audit of the process during the marketing phase of the product to ensure its compliance with these specifications. It is based on the concept that the process employed has been optimized, so that data generated through the testing program may be considered credible and evaluated for consistency as well as relevance. The activity starts when the pharmaceutical development department begins its work. Pertinent data or information are collected during the preformulation stage, and additional inputs are generated during formulation development and evaluation, process development, and full-scale manufacture. The information gathered in all four stages is evaluated to determine which parameters in the process can be used as possible tools to show that the product is under proper control. Once this is done, some other major steps in the development of a validation program are as follows:

1. Obtaining test data to determine the numerical range of each parameter e.g., assess the tablet hardness over a series of batches that achieves an acceptable friability, disintegration, and dissolution.

2. Establishing specification limits from the test data derived for a given parameter. Based on the data collected and using statistical techniques, determine the extremes of acceptable hardness (high and low) that would provide 95% assurance that the friability, disintegration, and dissolution specifications would be met (upper and lower control/release limits).
3. Determining how well the specification limit indicates that the process is under control. Challenge the process by producing product at the extremes of the specification limit to ensure all product specifications are met.
4. Certifying the equipment that is used in obtaining the data and controlling the process. Ensure that equipment operating conditions (e.g., rpm, temperature, power utilization) are within specification limits under variations of product load.

Once this has been done, one can proceed to actual product testing utilizing these parameters and their specifications to validate that the process will produce acceptable product. The testing can be conducted on samples during the manufacture (in-process tests) or on the finished product (finished product tests). Each product may have its own idiosyncrasies requiring special tests, but generally the in-process and finished product tests that would be required for all solid dosage forms in process validation are as follows.

#### **A. In-Process Tests**

1. *Moisture content of "dried granulation"*: Loss on drying (LOD) can be used to determine whether or not the granulation solvent has been removed to a sufficient level during the drying operation (usually less than 2% moisture).
2. *Granulation particle size distribution*: An extremely important parameter that can affect tablet compressibility, hardness, thickness, disintegration, dissolution, weight variation, and content uniformity. This parameter, which can be done by sieve analysis, should be monitored throughout the tablet validation process.
3. *Blend uniformity*: Samples of the blend are taken and analyzed to ensure that the drug is uniformly dispersed throughout the tablet/capsule blend. The proper blend time must be established so that the blend is not under- or overmixed. The sampling technique is critical for this test to be valid [45].
4. *Individual tablet/capsule weight*: The weight of individual tablets or capsules is determined throughout compression/encapsulation to ensure that the material is flowing properly and the equipment is work-

ing consistently. The individual weight should be within 5% of the nominal weight. Weight fluctuations or frequent machine adjustments suggest that the formulation/process (e.g., poor granulation flow) is not optimized and/or that the equipment may need maintenance.

5. *Tablet hardness*: Tablet hardness is determined periodically throughout the batch to ensure that the tablets are robust enough for coating, packing, and shipping and not too hard to affect dissolution.
6. *Tablet thickness*: Tablet thickness is also determined periodically throughout the batch and is indirectly related to the hardness. It is another indication of whether or not the formulation has proper flow and compression properties.
7. *Disintegration*: Disintegration is determined during the manufacture as a predictor of tablet performance (e.g., dissolution).

## B. Finished Product Tests

1. *Appearance*: The tablets should be examined for such problems as tablet mottling, picking of the monogram, tablet filming, and capping of the tablets. If the tablets are colored, the color quality needs to be examined.
2. *Assay*: This test will determine whether or not the product contains the labeled amount of drug.
3. *Content uniformity*: Samples are taken across the batch profile (beginning, middle, and end) and analyzed to ensure that the dosage forms comply with compendial standards ( $\pm 15\%$  of the labeled amount) or more stringent internal limits. It will indicate whether there is demixing during the manufacturing operation (i.e., segregation during flow of granulation from a storage bin).
4. *Tablet hardness*: A critical parameter for dosage form handling and performance.
5. *Tablet friability*: Friability is an important characteristic on the tablets' ability to withstand chipping, cracking, or "dusting" during the packaging operations and shipping.
6. *Dissolution*: Dissolution is important to ensure proper drug release characteristics (in vitro availability) and batch-to-batch uniformity.

These key test parameters are the yardsticks by which the major processing variables in solid dosage forms are evaluated. Some processing variables are:

Mixing time and speed in blenders and granulators  
Solvent addition rates in granulators  
Time, temperature, and airflow conditions in dryers and coaters  
Screen size, feed rate, and milling speed in mills



Machine speed and compression force in tablet presses  
Machine speed and fill volume in encapsulators.

Process validation testing is generally done on the first three batches of product made in production-size equipment. Revalidation testing is only done when a “significant” change has occurred. A significant change is one that will alter the in-process or final product specification established during the validation program or a change in formula, process, or equipment.

## **VI. GUIDELINES FOR PROCESS VALIDATION OF SOLID DOSAGE FORMS**

Numerous factors should be considered when developing and validating solid dosage forms. Figures 1 and 2 are flow charts for the validation of new and existing processes. As a means of providing a broad overview of these validation criteria, the following checklist/guideline is provided for tablets and dry-filled capsules for inclusion in an in-depth validation program. Some of these unit operations will not be applicable for every solid dosage form (e.g., direct compression tablets and uncoated tablets).

### **VII. TABLETS**

#### **A. Tablet Composition**

Identify the key physicochemical properties [17–19, 45–51] of the drug substance that need to be considered in developing the formulation, such as the following:

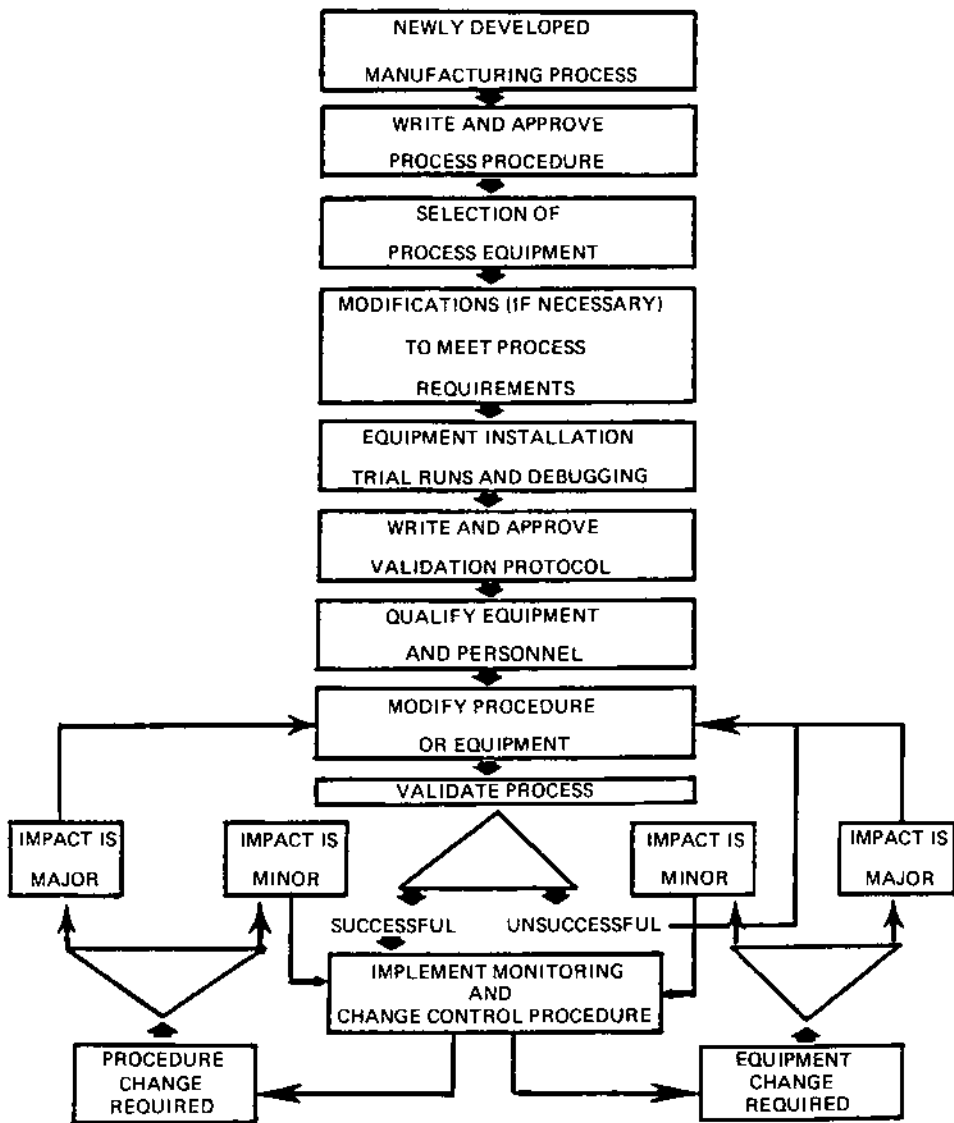
*Solubility of the drug substance throughout the physiological pH range:*

Depending on the solubility of the drug, a surfactant may be needed to enhance dissolution.

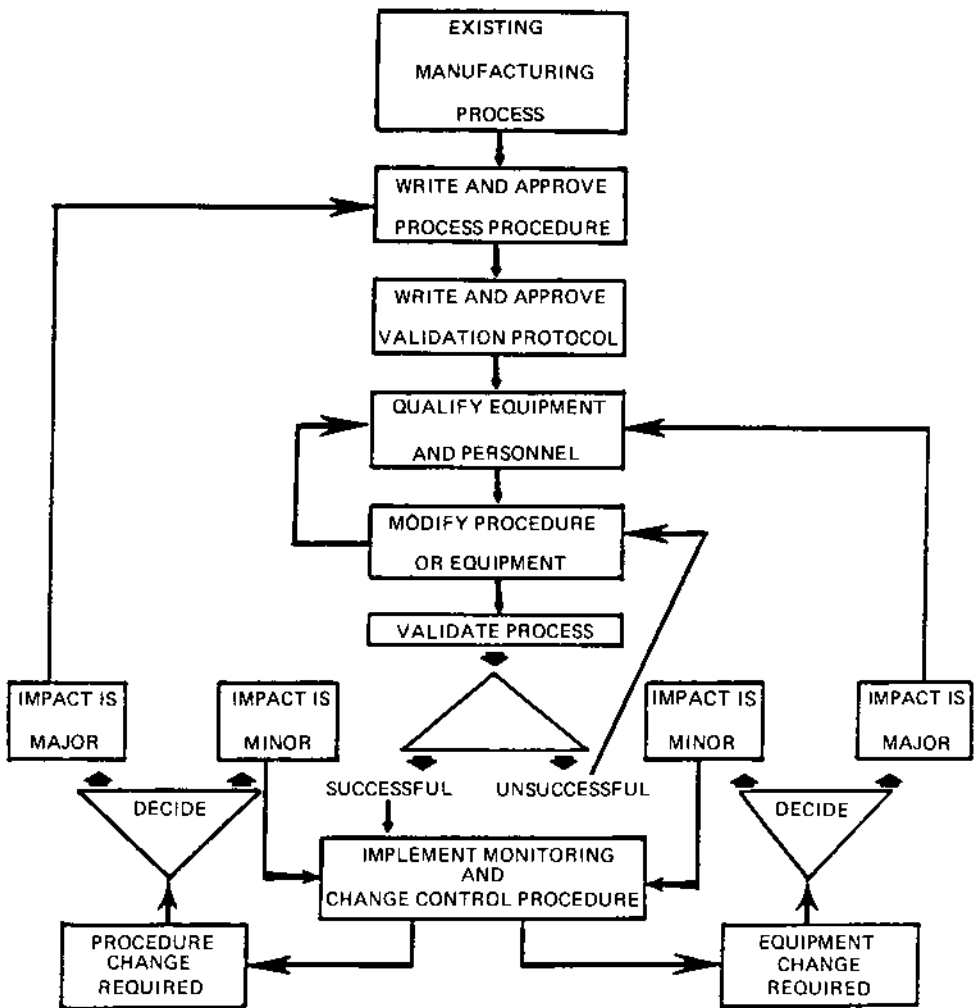
*Particle size distribution and surface area:* The particle size distribution of the drug may determine what grade of an excipient (e.g., microcrystalline cellulose) to use.

*Morphology:* If the drug is amorphous or has different polymorphs, certain excipients may be used to prevent conversion of the drug to other physical forms.

*True and bulk density:* An excipient (e.g., diluent) that has a similar bulk density as the drug may be selected to minimize segregation, especially with a direct compression formulation.



**Figure 1** Validation of new processes. (Courtesy of AstraZeneca Pharmaceuticals LP, Wilmington, Delaware.)



**Figure 2** Validation of existing processes. (Courtesy of AstraZeneca Pharmaceuticals LP, Wilmington, Delaware.)

*Material flow and compressibility:* A free flowing, highly compressible material such as microcrystalline cellulose may be used for drugs with poor flow or compressibility properties.

*Hygroscopicity:* Special environmental working conditions may be required to ensure that moisture is not picked up during material storage or handling and during the manufacture of the tablet dosage form.

*Melting point:* If the drug has a low melting point, a direct compression formulation may need to be developed instead of a wet granulation formulation to avoid drying the material and potentially melting or degrading the drug.

Provide the reason for the presence of each ingredient in the formula. Why was a particular ingredient (e.g., povidone) used from an excipient class (e.g., binder)? Performance? Supply? Cost? Indicate whether a particular grade or manufacturer is required for an ingredient and the reasons. Justify the level or range of each ingredient, especially the binder, disintegrant, and lubricant.

Explain the required unit operations in relationship to the tablet formulation. For example

Why was high shear wet granulation used instead of dry granulation?

Why is the tablet film coated?

## **B. Process Evaluation and Selection**

Determine the unit operations needed to manufacture the tablets.

### **1. Mixing or Blending**

The mixing or blending unit operation may occur once or several times during the tablet manufacture. For example, a direct compression formulation may involve one blending step in which the drug and the excipients are blended together prior to compression. A wet granulation formulation may require two mixing/blending steps: (1) prior to granulating to have a uniform drug/excipient mixture, and (2) after milling the dried granulation to add other excipients, such as the lubricant. Some or all the items provided in this section may therefore be pertinent for validation, depending on the mixing or blending objective.

The following physical properties of the drug and excipients are factors in creating a uniform mix or blend:

Bulk density

Particle shape

Particle size distribution

Surface area

Materials that have similar physical properties will be easier to form a uniform mix or blend and will not segregate as readily as materials with large differences. Items to consider:

*Mixing or blending technique:* Diffusion (tumble), convection (planetary or high intensity), or pneumatic (fluid bed) techniques can be used to mix or blend materials. Determine the technique that is required for the formulation or process objective. It may be different, depending on whether you are mixing the drug and excipients for a direct compression formulation or adding the lubricant (e.g., magnesium stearate) to the granulation.

*Mixing or blending speed:* Determine the intensity (low/high shear) and/or speed (rpm) of the mixing or blending. Mixing the drug and excipient will require more intense mixing than adding the lubricant to the final blend.

*Mixing or blending time:* How much mixing or blending is required to obtain a uniform mixture? The mixing or blending time will be dependent on the mixing or blending technique and speed. Experiments should be done to determine if the materials can be overmixed, resulting in demixing or segregation of the materials. Demixing can occur due to the physical property differences (e.g., particle size distribution and density). For example, demixing can occur in a direct compression formulation in which the drug substance is micronized (5 microns) and the excipients are granular (500–1000 microns).

*Drug uniformity:* Content uniformity is usually performed to determine the uniformity of drug throughout the mix or blend. Representative samples should be taken throughout the mix or blend. The sampling technique and handling of the materials are key in obtaining valid content uniformity results. Segregation of the sample can occur by overhandling, resulting in inaccurate results. For the final blend (blend prior to compression), the sample taken should be equivalent to the weight of a single tablet.

*Excipient uniformity:* Besides drug uniformity, excipients need to be uniform in the granulation or blend. Two key excipients are:

- *Lubricant:* The lubricant needs to be distributed uniformly in the mixture/granulation for the high-speed compression operation. Uneven distribution of the lubricant can result in picking and sticky problems during compression. It can also lead to tablet performance problems (low dissolution due to excessive lubricant in some tablets).
- *Color:* The colorant(s) need(s) to be evenly distributed in the mixture so that the tablets have a uniform appearance (e.g., color, hue, and intensity). The coloring agent may need to be prescreened or more uni-

formally dispersed in the blend prior to compression to avoid speckling or shading of the color.

- *Equipment capacity/load*: The bulk density of materials or granules will affect the capacity of the equipment. If an excipient in the formulation affects the density of the final blend to a greater extent than any other ingredient, then a well-controlled density specification for that excipient may be warranted. Test different-sized loads in the mixer/blender (e.g., 30, 50, and 70% of working volume) for optimal mixing or blending. Undercharging or overcharging a blender can result in poor drug or tablet lubricant distribution.

## 2. Wet Granulation

What type of wet granulation technique will be used? Will it be low shear (e.g., Hobart), high shear (e.g., Diosna, GEI-Collette) or fluid bed (e.g., Glatt, Fluid Air)? Each technique will produce granules with different physical properties and will require monitoring of different processing parameters.

Wet granulation parameters to be considered during development and validation are:

*Binder addition*: Should the binder be added as a granulating solution or dry like the other excipients? Adding the binder dry avoids the need to determine the optimal binder concentration and a separate manufacture for the binder solution.

*Binder concentration*: The optimal binder concentration will need to be determined for the formulation. If the binder is to be sprayed, the binder solution needs to be dilute enough so that it can be pumped through the spray nozzle. It should also be sufficiently concentrated to form granules without overwetting the materials.

*Amount of binder solution/granulating solvent*: How much binder or solvent solution is required to granulate the material? Too much binder or solvent solution will overwet the materials and prolong the drying time. The amount of binder solution is related to the binder concentration.

*Binder solution/granulating solvent addition rate*: Define the rate or rate range at which the binder solution or granulating solvent can be added to the materials. Can the granulating solution be dumped into the mixer or does it have to be metered in at a specific rate?

*Mixing time*: How long should the material be mixed to ensure proper formation of granules? Should mixing stop after the addition of the binder or solvent solution or should additional mixing be required? Granulations that are not mixed long enough can form incomplete or weak granules. These granules may have poor flow and compression

properties. On the other hand, overmixing the granulation can lead to harder granules and a lower dissolution rate.

*Granulation end point:* How is the granulation end point determined? Is it determined or controlled by granulation end point equipment (e.g., ammeter or wattmeter)? Is it controlled by specifying critical processing parameters? For example, a drug or excipient mixture may be granulated by adding a predetermined amount of water (granulating solution) at a certain rate. The granulation is completed after mixing for a set time after the water has been added.

### 3. Wet Milling

Does the wet granulation need to be milled to break up the lumps and enhance drying of the granulation? Wet granules that have a wide aggregate range can lead to inefficient drying (long drying times and partially dried large granules or lumps).

Factors to consider are:

1. *Equipment size and capacity:* The mill should be large enough to delump the entire batch within a reasonable time period to minimize manufacturing time and prevent the material from drying during this operation.
2. *Screen size:* The screen needs to be small enough to delump the material, but not too small to cause excessive heating of the mill, resulting in drying of the granulation.
3. *Mill speed:* The speed should be sufficient to efficiently delump the material without straining the equipment.
4. *Feed rate:* The feed rate of the wet granulation is interrelated to screen size and mill size and speed.

### 4. Drying

The type of drying technique (e.g., tray, fluid bed, microwave) required for the formulation needs to be determined and justified. The type of technique may be dependent on such factors as drug or formulation properties and equipment availability. Changing dryer techniques could affect such tablet properties as hardness, disintegration, dissolution, and stability.

The optimal moisture content of the dried granulation needs to be determined. High moisture content can result in (1) tablet picking or sticking to tablet punch surfaces and (2) poor chemical stability as a result of hydrolysis. An overdried granulation could result in poor hardness and friability. Moisture content analysis can be performed using the conventional loss-on-drying techniques or such state-of-the-art techniques as near infrared (NIR) spectroscopy.

Parameters to consider during drying are:

*Inlet/outlet temperature:* The inlet temperature is the temperature of the incoming air to the dryer, while the outlet temperature is the temperature leaving the unit. The inlet temperature is critical to the drying efficiency of the granulation and should be set high enough to maximize drying without affecting the chemical/physical stability of the granulation. The outlet temperature is an indicator of the granulation temperature and will increase toward the inlet temperature as the moisture content of the granulation decreases (evaporization rate).

*Airflow:* There should be sufficient airflow to ensure removal of moisture-laden air from the wet granulation. Insufficient airflow could prolong drying and affect the chemical stability of the drug. Airflow and the inlet/outlet temperature are interrelated parameters and should be considered together.

*Moisture uniformity:* The moisture content could vary within the granulation. Heat uniformity of the dryer (e.g., tray), amount of granulation per tray, and incomplete fluidization of the bed are factors that could affect the moisture uniformity of the granulation.

*Equipment capability/capacity:* The load that can be efficiently dried within the unit needs to be known. A larger load will require more moisture to be removed on drying and will affect the drying time. In the case of fluid bed drying, a maximum dryer load is that load above which the dryer will not fluidize the material.

## 5. Milling

The milling operation will reduce the particle size of the dried granulation. The resultant particle size distribution will affect such material properties as flow, compressibility, disintegration, and dissolution. An optimal particle size/size distribution for the formulation will need to be determined.

Factors to consider in milling are:

*Mill type:* What mill type (e.g., impact or screen) should be used? Each has several variants, depending on the means to reduce the particles. The type of mill can generate a different particle size/size distribution. Particle size testing will need to be conducted and the results examined when substituting mill types.

*Screen size:* The selected screen size will affect the particle size. A smaller screen size will produce a smaller particle size and a greater number of fines.

*Mill speed:* What is the optimal mill speed? A higher mill speed will result in a smaller particle size and possibly a wider particle size distri-



bution. It can also generate more heat to the product, depending on the screen size and feed rate, which could affect the stability of the product.  
*Feed rate:* The feed rate is dependent on the mill capacity, screen size, and mill speed.

## 6. Tablet Compression

Compression is a critical step in the production of a tablet dosage form. The materials being compressed will need to have adequate flow and compression properties. The material should readily flow from the hopper onto the feed frame and into the dies. Inadequate flow can result in “rat holing” in the hopper and/or segregation of the blend in the hopper/feed frame. This can cause tablet weight and content uniformity problems. As for the compressibility properties of the formulation, it should be examined on an instrumented tablet press.

Factors to consider during compression are as follows:

*Tooling:* The shape, size, and concavity of the tooling should be examined based on the formulation properties and commercial specifications. For intagliated (embossed) tablets, factors such as the position of the intagliation on the tablet and the intagliation depth and style should be examined to ensure that picking of the intagliation during compression or fill-in of the intagliation during coating does not occur.

*Compression speed:* The formulation should be compressed at a wide range of compression speeds to determine the operating range of the compressor. The adequacy of the material’s flow into the dies will be determined by examining the tablet weights. Is a force feeder required to ensure that sufficient material is fed into the dies?

*Compression/ejection force:* The compression profile for the tablet formulation will need to be determined to establish the optimal compression force to obtain the desired tablet hardness. The particle size/size distribution or level of lubricant may need to be adjusted in order to have a robust process on a high-speed compressor.

The following in-process tests (as discussed in Sec. V) should be examined during the compression stage:

- Appearance
- Hardness
- Tablet weight
- Friability
- Disintegration
- Weight uniformity

## 7. Tablet Coating

Tablets may be coated for various reasons.

- Stability
- Taste masking
- Controlled release
- Product identification
- Aesthetics
- Safety–material handling

Tablet coating can occur by different techniques (e.g., sugar, film, or compression). Film coating has been the most common technique over recent years and will be the focus of this section.

Key areas to consider for tablet coating include the following:

*Tablet properties:* Tablet properties such as hardness, shape, and intagliation (if required) are important to obtain a good film-coated tablet. The tablet needs to be hard enough to withstand the coating process. If tablet attrition occurs, the tablets will have a rough surface appearance. For tablet shape, a round tablet will be easier to coat than tablets with multiple sides or edges because of the uniformity of the surface. For intagliated tablets, the intagliation style and depth should be developed to prevent fill-in or chipping of the intagliation.

*Equipment type:* The type of coater will need to be selected. Conventional or perforated pan and fluid bed coaters are potential options.

*Coater load:* What is the acceptable tablet load range of the equipment? Having too large a pan load could cause attrition of the tablets because of the overall tablet weight in the coater. In the case of a fluid bed coater, there may not be sufficient airflow to fluidize the tablets.

*Pan speed:* What is the optimal pan speed? This will be interrelated to other coating parameters, such as inlet temperature, spray rate, and flow rate.

*Spray guns:* The number and types of guns should be determined in order to efficiently coat the tablets. The spray nozzles should be sized properly to ensure even distribution over the tablet bed and to prevent clogging of the nozzles. The location and angle of the spray gun(s) should be positioned to get adequate coverage. Having the guns positioned too close together can lead to a portion of the tablets to be overwet.

*Application/spray rate:* The optimal application/spray rate should be determined. Spraying too fast will cause the tablets to become overwet, resulting in clumping of tablets and possible dissolution of the tablet surface. Spraying too slowly will cause the coating materials to dry

prior to adhesion to the tablets. This will result in a rough tablet surface and poor coating efficiency.

*Tablet flow:* The flow or movement of the tablets in the coater should be examined to ensure proper flow. There should be sufficient tablet bed movement to ensure even distribution of the coating solution onto the tablets. The addition of baffles may be required to provide adequate movement of tablets for tablet coating.

*Inlet/outlet temperature and airflow:* These parameters are interrelated and should be set to ensure that the atomized coating solution reaches the tablet surface and then is quickly dried.

*Coating solution:* The concentration and viscosity of the coating solution will need to be determined. The solution will need to be sufficiently diluted in order to spray the material on the tablets. The concentration of the coating solution will also determine the amount and volume of solution to be applied to the tablets. The stability of the coating solution should be investigated to establish its shelf life.

*Coating weight:* A minimum and maximum coating weight should be established for the tablet. Sufficient coating material should be applied to the tablets to provide a uniform appearance; however, it should not be great enough to cause fill-in of the intagliation.

*Residual solvent level:* If solvents are used for tablet coating, the residual solvent level will need to be determined.

Appearance testing of the tablets is critical during the coating operation. Items to look for include the following:

- Cracking or peeling of the coating
- Intagliation fill-in
- Surface roughness
- Color uniformity

Coating efficiency should be determined for the coating operation. The efficiency will determine the amount of coating solution overage that may be required.

### **C. Equipment Evaluation**

In an ideal situation, the equipment used to manufacture tablet dosage forms would be selected based on such factors as formulation, safety requirements, handling/production efficiencies, and commercial demands. In reality, the equipment used is usually what is already available at the development facility or production plant. In either case, the equipment should be qualified (installation and operation) before being used. Cleaning procedures should also be available

to ensure that cross-contamination does not occur. The equipment design, operating principles, and capacity should be investigated.

The following items should be considered when evaluating equipment for the manufacture of the tablet dosage forms.

1. Mixer/granulator
  - a. What is the method of mixing (e.g., planetary, plows, choppers, pneumatic)?
  - b. Is the equipment capable of providing low and/or high shear to the material?
  - c. Can the mixing be varied (e.g., changing the rpm of the impeller)?
  - d. Does the mixer/granulator have a monitoring system (e.g., end point detection) or can it accommodate one?
  - e. What is the working load range and capacity of the equipment?
  - f. How is material charged and discharged from the unit? Is it manual, semiautomated, or automated?
  - g. Are there options to introduce the granulating fluid (e.g., dump, meter, or spray)?
2. Blender
  - a. What type (i.e., geometric shape) is the blender? Is it a V blender, double cone, cube, or bin?
  - b. What is the positioning of the axis rotation (e.g., horizontal, slant)?
  - c. What is the working load range and capacity of the equipment?
  - d. What features does the equipment have for ease of handling powders, automated charging, and discharging (e.g., Vac-U-Max, Gemco valves)?
  - e. Can samples be easily taken from the unit? Can samples be taken from more than one location?
  - f. Are there dead spots (inefficient mixing areas) on the unit?
  - g. Can the equipment be easily cleaned?
  - h. Can the equipment heat the powder blend if needed? What is the heating source?
3. Dryer
  - a. What is the operating principle of the dryer (e.g., direct heating—fluid bed, indirect conduction—tray, or indirect radiant—microwave)?
  - b. Will the wet material be static (e.g., tray) or fluid (e.g., fluid bed)?
  - c. What is the working load range and capacity of the equipment?
  - d. What is the heating range and airflow capabilities of the equipment?

- e. What is the heat distribution of the unit? Are there any hot and/or cold spots?
  - f. Can the unit pull a vacuum? What is the vacuum range of the unit?
  - g. Can the equipment handle different types of filter bags? For example, can a filter bag be dedicated to a particular product?
  - h. Does the equipment have a filter bag shaking mechanism to prevent material from adhering to the bags? Does the shaking mechanism have options (e.g., intermittent, continuous)?
4. Mills
- a. What is the mill type (e.g., impact or screen)?
  - b. What is the configuration of the impact mill (e.g., hammer or pin/disc) or screen mill (e.g., rotating impeller or screen, oscillating bar)?
  - c. What type or size hammers or pin/disc can be used on the unit?
  - d. Can the impeller (e.g., hammers) be positioned in different ways?
  - e. What size screens or plates can be used on the unit?
  - f. Is the speed on the impeller/screen variable? What is the rpm range?
  - g. What is the throughput range of the unit?
  - h. What type of feed system is required? What feed rate can the unit handle?
  - i. Can the unit wet- and/or dry-mill materials?
  - j. Does the unit generate a significant amount of heat, possibly affecting the product?
  - k. Is the unit portable?
5. Tablet compressor
- a. How many compression stations does the compressor have?
  - b. What is the operating range (rpm) of the unit?
  - c. What is the output range of the compressor (e.g., tablets per min)? Will the unit meet the demands (sales forecast) for the product?
  - d. What kind of powder feeding capabilities does the equipment have (e.g., gravity, power-assisted, or centrifugal)? Can this capability be altered or controlled (e.g., open feed frame, forced below feeder)?
  - e. What is the compression force range of the equipment? Some products, especially large tablets or slugs, require a significant compression force (greater than 5 to 25 kN).
  - f. Is the equipment capable of monitoring compression and ejection force?
  - g. Does the unit have precompression capabilities?
  - h. How long can the equipment operate without routine maintenance? This is related to air drag-off from the compression table,

compression rolls and ejection cams, and the lubrication system (oil misting).

- i. How long is the turnaround time for complete cleaning? One shift? Two shifts? This downtime can be significant and may affect the need for a multishift tableting operation or numerous tablet machines.
  - j. Does the equipment possess automated weight control capability (e.g., Thomas's Sentinel device)?
  - k. Does the equipment require specialized tooling, or can the equipment use tooling from other equipment (e.g., length of punch shafts, diameter of dies)?
  - l. Can the equipment perform a specialized function in addition to basic tablet compression (e.g., multilayer tablet compression, compression coating)?
  - m. Is the unit capable of being contained to protect the operator and environment?
6. Tablet Coater
- a. What is the coater type (e.g., pan or fluid bed)?
  - b. Is the pan perforated?
  - c. Can the coater accommodate different size pans?
  - d. What is the working capacity range of the coater (i.e., pan load)?
  - e. Does the pan coater have a "variable drive" capability? This may be needed to achieve proper tablet mixing in the pan so that the coating solution is applied uniformly to the tablets.
  - f. Can the angle of the pan's pitch be varied?
  - g. What kind of air input (volume and temperature) and vacuum drag-off is required for optimal operation of the coater? These utility requirements may exceed the capacities available in the plant.
  - h. What type of spray system can be used with the equipment?
  - i. What is the shape of the coating pan (e.g., oval, mushroom, round)? The shape characteristic will affect the degree of agitation and the direction of tablet flow in the pan. The spray nozzle configuration will have to be designed to ensure adequate spray coverage over the tablet bed.
  - j. Is it possible to utilize the equipment for sugar coating as well as film coating? Certainly, if this were possible, capital expenditures would be reduced.
  - k. Is it possible to modify the pan with the installation of baffles? Baffles may be needed to ensure good tablet movement in the pan.
  - l. Can various solvents (ethanol) be used in the equipment?

- m. Does the equipment require a specialized room condition (e.g., being explosion-proof)?

## VIII. HARD GELATIN CAPSULES

Many of properties and processes for hard gelatin capsules [19,48] are the same as with tablet dosage forms. Instead of covering these items again, only items that are unique to hard gelatin capsules will be discussed in this section.

### A. Capsule Composition

The composition of the capsule contents would be similar to that presented in the tablet composition section. The capsule shell and the interactions of the shell and the contents will be discussed further.

#### 1. Capsule Shell

Provide the reason for the presence of each ingredient in the capsule formula.

Justify the level and grade of each ingredient.

Explain the selection of the capsule size and shape.

Discuss the need for capsule identification (e.g., color or imprinting).

#### 2. Capsule Shell Contents

Establish the compatibility of the capsule shell and the capsule contents.

Determine the hygroscopic nature of the capsule formulation. For example, a hygroscopic formulation (active ingredient and/or excipients) can pull water from the capsule shell, which could affect the

Active ingredient—stability issues such as degradation and morphology changes

Formulation—hardening on the materials, resulting in a decreased dissolution rate

Capsule shell—more brittle

### B. Process Evaluation and Selection

The process to manufacture the contents of a hard gelatin capsule is the same as a tablet. It may required only a blending step, such as a direct compression tablet, or several unit operations, such as a wet granulation tablet (e.g., mixing, wet milling, drying, dry milling, and blending). In either case, the materials are then encapsulated in a capsule shell.

## C. Encapsulation

Encapsulation is a critical step in the production of capsules, similar to the compression step for tablet dosage forms. The materials to be encapsulated will need to have good flow properties and a consistent density. The materials may also need to be compressible in order to be dosed into the capsules; however, they should also be easily deaggregated so not to adversely affect the dissolution of the drug.

Factors to consider during encapsulation are:

*Encapsulation type:* The type of encapsulation technique (e.g., auger, vacuum, dosator) required for the formulation needs to be determined and justified. Examples are

Auger: Capsugel Type B or Elanco No. 8

Vacuum: Perry

Vibratory: Osaka

Dosing disk: H&K

Dosator: MG2 or Zanasi

The type of technique may be dependent on such factors as drug or formulation properties and equipment availability.

*Encapsulation speed:* The formulation should be encapsulated at a wide range of speeds to determine the operating range of the encapsulator.

By examining the capsule weights, the adequacy of the material's flow will be determined.

The following in-process tests (as discussed in Sec. V) should be examined during the encapsulation step:

Appearance

Capsule weight

Disintegration

Weight uniformity

## D. Equipment Evaluation

### 1. Encapsulator

1. What is the encapsulation mechanism (e.g., auger, dosing disk, dosator)?
2. How many encapsulation stations does the encapsulator have?
3. What is the operating range of the unit?
4. What is the output range of the encapsulator (i.e., capsules per min)?  
Will the unit meet the demands (sales forecast) for the product?
5. What kind of powder feeding capabilities does the equipment have



- (e.g., gravity- or power-assisted)? Can this capability be altered or controlled?
6. How long can the equipment operate without routine maintenance?
  7. How long is the turnaround time for complete cleaning? This downtime can be significant and may affect the need for a multishift operation or additional machines.
  8. Does the equipment possess automated weight control capability?
  9. Can the equipment perform a specialized function in addition to basic encapsulation (e.g., tablet in capsules with excipient backfill)?
  10. Is the unit capable of being contained to protect the operator and environment?

## **IX. OUTSOURCING IMPLICATIONS ON VALIDATION**

In recent years, outsourcing, in response to financial and time-to-market pressures, has greatly increased within the pharmaceutical industry. Today, third party providers are being used at a rate of 40–50% to supplement internal R&D, manufacturing, and sales and marketing activities. While the majority of outsourcing remains tactical (transactional), there is an increasing movement to strategic outsourcing characterized by partnerships and alliance relationships.

The use of third party suppliers does not absolve the pioneer pharmaceutical firm from ensuring that validation is conducted in a scientific and comprehensive manner. The FDA and other regulatory bodies will hold the pioneer company fully responsible for validation, as it—validation—is the foundation for all information and data being generated to support new drug applications. As part of the due diligence process, therefore, clients must ensure that suppliers have validation procedures and practices in place. Once a supplier is chosen and work commences, the client must include validation auditing as part of the ongoing relationship monitoring to ensure that it is being successfully practiced.

Analytical testing (preformulation, stability, product release) is a core component of pharmaceutical operations from early R&D through manufacturing of the commercial product. The original analytical methods are usually developed by the pioneer pharmaceutical firm and transferred to the provider. In some cases, the early methods are only preliminary methods and are not sufficiently robust to test the quality of downstream (clinical, commercial, and line extension) products and facility quality practices (cleaning validation). In those situations, the supplier is often asked to develop new methods, and in some cases those methods are transferred back to the client. In either scenario, the transfer of validated analytical methodology consists of the following four main tasks [52]:

1. Training of the contract analysts by the client R&D group
2. Agreeing on an interlaboratory qualification protocol
3. Cross-validating the analytical method by simultaneous testing at both sites
4. Statistically comparing the data generated by both sites and qualification by quality assurance (QA)

In recent years, the International Conference on Harmonization (ICH) has published two documents that serve as expert guidance on analytical and related validation [53,54]. As part of the outsourcing process, the client and provider should review these and related regulatory guidances (e.g., cleaning validation) to ensure that there is a mutual understanding and agreement on the scientific basis of methods validation.

## **X. CONCLUSIONS**

The guidelines contained within this chapter should be considered as part of a comprehensive validation program for solid oral dosage forms. The unique formulation or process characteristics of a particular product and the equipment available to manufacture that product may dictate the need for a specialized validation program. As such, the multidisciplinary validation team must identify the product and process characteristics that must be studied and incorporate specific validation tests to ensure that that product will meet all quality, manufacturing, and regulatory requirements.

Solid dosage form validation should be part of a comprehensive validation program within a company. The total program should begin with validation of the active pharmaceutical ingredient (API) characteristics so that this material will be uniform batch after batch, providing a solid footing upon which the dosage form will be built. A raw material evaluation committee, comprising personnel from formulation, analytical and process development, quality control, and purchasing, should determine the extent to which a new or alternate material must be evaluated before it can be considered acceptable for routine use.

Analytical methods validation is a critical component of the entire company validation program. A method is not declared acceptable until a collaborative crossover study is conducted between two development laboratories and at least one quality control laboratory to ensure proper precision, accuracy, and efficiency. In the new world of outsourcing, it is imperative that an analytical crossover study be conducted between the client and supplier before any work is begun on dosage form development.

Validation of a new or existing product involves the efforts of scientists at various stages of the product development life cycle. Scientific information

obtained during the preformulation stage can form the basis for a well-designed and comprehensive validation program. As development proceeds, validation considerations are broadened to ensure that critical formulation, analytical, and process factors are integrated into the overall validation program. The parameters chosen must be relevant indicators of a controlled process. It is not sufficient merely to devise a test and set specifications for it; rather, it is desirable to show a cause and effect relationship between the parameter tested and control of the quality and/or process output.

While validation as a discipline is widely known across the pharmaceutical industry, there are still a significant number of instances in which preapproval inspection results or product recalls identify an insufficient validation program as the root cause of the difficulty. Continued awareness of validation requirements and a diligent application of validation principles will thus help to ensure that pharmaceutical products will be able to be developed and produced with the quality and reproducibility required from regulatory agencies across the world.

## REFERENCES

1. Chapman, K. G. A history of validation in the United States: Part I. *Pharm Tech* 15(10): 82–96 (1991).
2. Tetzlaff, R. F., Sheppard, R. E., LeBlanc, A. J. The validation story: Perspectives on the systemic GMP inspection approach and validation development. *Pharm Tech March:100–116* (1993).
3. Nusch, K. Validation issues for OTC drug manufacturers. *Global Cos Ind March: 34–38* (2000).
4. Nash, R. A. Process validation for solid dosage forms. *Pharm Tech June:105–107* (1979).
5. Duffell, W. Industry perspectives of pre-approval inspections. PMA-RAC Meeting, Washington, DC, May 16, 1991.
6. Boglivi, D. Preparing for pre-approval inspections, DIA Meeting, Feb. 6, 1992.
7. Lee, J. Y. Documentation requirements for pre-approval inspections. *Pharm Techn March: 154–164* (1993).
8. Hodgson, G. A practical guide to executing validation protocols. *Biopharm April: 30–32* (1999).
9. U.S. FDA. Guideline on general principles of process validation. *Guide Indus May* (1987).
10. Byers, T. E. Validation: A systematic approach to quality assurance. Pharm. Tech. Conference, New York, Sept. 1981.
11. Loftus, B. E. Validation protocol: The bottom line, Proprietary Association–Manufacturing Control Seminar, Cherry Hill, NJ, Oct. 9, 1980.
12. Byers, T. E. Role of product and process design in assuring quality, Good Manufacturing Practices Conference, Cherry Hill, NJ, Feb. 1977.

13. von Doehren, P. J. An approach to the characterization of solid dosage forms. Pharm. Tech. Conference, New York, Sept. 1981.
14. Harpaz, D. Process evaluation/validation of solid dosage forms. Pharm. Tech. Conference, New York, Sept. 1981.
15. Samyn, J. C. New product validation begins in R&D. PMA Seminar on Validation, Atlanta, May 1980.
16. Berry, I. R. Process validation of raw materials. *Pharm Techn Feb.*:38–39 (1981).
17. U.S. FDA. Guide to inspections of oral solid dosage forms pre/post approval issues for development and validation. *Guide Indus Jan.* (1994).
18. U.S. FDA. Immediate release solid oral dosage forms scale-up and postapproval changes: Chemistry, manufacturing, and controls. In vitro dissolution testing, and in vivo bioequivalence documentation *Guide Indus Nov.* (1995).
19. Nash, R. A. Process validation: A 17-year retrospective of solid-dosage forms. *Drug Dev Ind Pharm 21(1)*:25–34 (1996).
20. Kumkumian, C. OK, Your candidate drug has activity: Now what? *Chemtech March*:178–180 (1980).
21. Rippie, E. G. Mixing. In: L. Lockman, H. Lieberman, I. Kanig, eds. *Theory and Practice of Industrial Pharmacy*. 2nd ed. Philadelphia: Lea & Febiger, pp. 486–502 (1976).
22. Parrott, E. L. Mixing. In: L. Lockman, H. Lieberman, I. Kanig, eds. *Theory and Practice of Industrial Pharmacy*. 2nd ed. Philadelphia: Lea & Febiger, pp. 466–485 (1976).
23. Moreton, R. C. Tablet excipients to the year 2001: A look into the crystal ball. *Drug Dev Ind Pharm 22(1)*:11–23 (1996).
24. Landin, M., Martinez-Pacheco, R., Gomez-Amoza, J. L., Souto, C., Concheiro, A., Rowe, R. C. Effect of country of origin on properties of microcrystalline cellulose. *Internat J Pharm 91*:123–131 (1993).
25. Doelker, E., Mordier, D., Iten, H., Humbert-Droz, P. Comparative tableting properties of sixteen microcrystalline cellulose. *Drug Dev Ind Pharm 13*:1847–1975 (1987).
26. Landin, M., Martinez-Pacheco, R., Gomez-Amoza, J. L., Souto, C., Concheiro, A., Rowe, R. C. Effect of batch variation and source of pulp on the properties of microcrystalline cellulose. *Internat J Pharm 91*:133–141 (1993).
27. Rowe, R. C., McKillop, A. G., Bray, D. The effect of batch and source variation on the crystallinity of microcrystalline cellulose. *Internat J Pharm 101*:169–172 (1994).
28. Parker, M. D., York, P., Rowe, R. C. Binder-substrate interactions in wet granulation 3: The effect of excipient source variation. *Internat J Pharm 80*:179–190 (1992).
29. Landin, M., Martinez-Pacheco, R., Gomez-Amoza, J. L., Souto, C., Concheiro, A., Rowe, R. C. Influence of microcrystalline cellulose source and batch variation on tableting behavior and stability of prednisone formulations. *Internat J Pharm 91*: 143–149 (1993).
30. Shah, A. C., Mlodozienec, A. R. Mechanism of surface lubrication: Excipient mixing on processing characteristics of powders and properties of compressed tablets. *J Pharm Sci 66*:1377–1382 (1977).

31. Dansereau, R., Peck, G. E. The effect of the variability in the physical and chemical properties of magnesium stearate on the properties of compressed tablets. *Drug Dev Ind Pharm* 13:975–999 (1987).
32. Barra, J., Somma, R. Influence of the physicochemical variability of magnesium stearate on its lubricant properties: Possible solutions. *Drug Dev Ind Pharm* 22(11): 1105–1120 (1996).
33. Billany, M. R., Richards, J. H. Batch variation of magnesium stearate and its effect on the dissolution rate of salicylic acid from solid dosage forms. *Drug Dev Ind Pharm* 8:497–511 (1982).
34. Hussain, M. S. H., York, P., Timmins, P. Effect of commercial and high purity magnesium stearates on in-vitro dissolution of paracetamol DC tablets. *Internat J Pharm* 78:203–207 (1992).
35. Avallone, H. Laboratory controls & compliance. *J cGMP Comp* 1(4):8–13 (1997).
36. Huber, L. Validation of analytical methods: Review and strategy. *LC/GC Intl* 11(2): 96–105 (1998).
37. *BioPharm Outs Rep* 5(5), (May 2000).
38. Tedesco, J. Auditing contract analytical laboratories. *J cGMP Comp* 1(4):33–43 (1997).
39. King, P. G. Equipment validation. *J Val Tech Aug.*:345–354 (1997).
40. Hodgson, G. S. A practical guide to executing validation protocols. *BioPharm April*:30–32 (1999).
41. Tisak, D. J., Koster, R. E. Validation commissioning documents. *J Val Tech Aug.*: 394–397 (1997).
42. Pepper, C., Patel, M., Hartounian, H. CGMP Pharmaceutical scale-up—Installation, commissioning, development. *BioPharm Feb.*:28–32 (2000).
43. Agalloco, J. Master planning and validation—Anatomy of a validation master plan. *BioPharm March*:40–44 (2000).
44. Angelucci, L. A. Validation and commissioning. *Pharm Eng Jan./Feb.*:40–44 (1998).
45. Berman, J., Planchard, J. A. *Drug Dev Ind Pharm* 21(11):1257–1283 (1995).
46. Riffino, C. B. Guideline for scale-up of dried filled capsules and tablets. Astra-Zeneca (Stuart) Pharmaceuticals Internal Document, Feb. 17, 1978.
47. Spiller, B. A. Process validation program. AstraZeneca (Stuart) Pharmaceuticals Internal Document, July 28, 1978.
48. U.S. FDA. SUPAC-IR/MR: Immediate release and modified release solid oral dosage forms manufacturing equipment addendum. *Guide Indus Jan.* (1999).
49. Armstrong, N. A. Selection of excipients for direct compression tablet formulations. *Pharm Tech Eur Sept.*:24–30 (1997).
50. Murray, F. Tablet press automation: A modular approach to fully integrated production. *Drug Dev Ind Pharm* 22(1):35–43 (1996).
51. Signorino, C. Dynamics of aqueous film coating. *Pharm Man Internat* 149–152 (1997).
52. Scull, J. R. Outsourcing analytical testing for non-clinical studies. *Contr Pharm Jan./Feb.*:20–24 (2000).
53. U.S. FDA. ICH guideline on the validation of analytical methodology. *Fed Reg* 62(96):27463–27467 (1997).
54. U.S. FDA. ICH text on validation of analytical procedures. *Guide Indust March* (1995).

# 6

## Validation for Medical Devices

**Toshiaki Nishihata**

*Santen Pharmaceutical Co., Ltd., Osaka, Japan*

### I. MEDICAL DEVICES AND CATEGORIES

In general, a medical device is defined as follows: a medical device is an implant and equipment to be used either to achieve disease diagnosis, medical treatment, or disease prevention for human and animals, or to influence the physical structure and function of human and animals. Medical devices for humans may also be classified based on whether and how long the device is in contact with tissue or cells and on the degree of disjunction induced by the device when in a disabling situation. The term covers various categories, such as scissors and tweezers, with small risk to human function, to central venous catheters, artificial dialysis (human kidney), and pacemakers, with high risk to human function.

The ISO (International Standards Organization) standard (ISO 13485 [1]) for medical devices, Quality Assurance System for Medical Devices, has been implemented globally. GMPs are clearly required for the manufacture of medical devices, including process control, quality control, and appropriate facilities and equipment. GMP also plays a role in maintaining the quality of medical devices. Performing only a specification test of the final product for release may not guarantee high quality of the device; design qualification/verification in the development step must be done in detail and process control by scientific parameters is important to assure quality. Because the term medical device covers a variety of categories, it may be difficult to establish a simple quality control system. To achieve appropriate quality control status, medical devices may be categorized under design, manufacturing method, assembly method, and quality control testing, as shown in [Table 1](#).

The medical devices in category 1 in [Table 1](#) are controlled during in-

**Table 1** Categories of Medical Devices Based on Their Design, Manufacturing Method, Assembly Method, and Quality Control Testing

---

Category 1: Medical devices that are controlled by in-process tests, with critical specifications designed for both individual products and a group, but not implemented in human and animals.

Category 2: Medical devices that are composed in batches and are tested with representatives in a batch.

Category 3: Medical devices that are controlled with each component (part) for assembly in the manufacturing process, and constituted (assembled) and maintained at the user site. Of course, the function of the medical device after assembly must be tested before release.

Category 4: Medical devices that are controlled by in-process tests, with critical specifications designed for both individual products or a group, and are implemented in human and animals for the long term.

---

process testing with critical specifications designed either for individual products or a group of products. Qualification of equipment to test critical product specifications and validation of test methods should be key factors. In this category, scissors, tweezers, and a pair of glasses are involved.

The medical devices for category 2 in Table 1 are composed in batch. Process validation should be a key factor in manufacturing uniform products. In this category, sterile products, such as central venous catheters and ophthalmic viscosurgical solution without pharmacological and metabolic action, are involved. In vitro diagnostic products are also involved in this category.

The medical devices for category 3 in Table 1 are constituted (assembled) at the user site. Method verification for constitution should be one of the key factors, as well as qualification and validation in the manufacture of components (parts). Nuclear magnetic resonance spectroscopy (NMR) is included in this category.

The medical devices in category 4 of Table 1 are controlled in-process testing with critical specifications designed for individual products or a group of products and are implanted. The compatibility of product materials with tissue and cells, the stability of product in the implanted site, and the sterility of product should be key factors to assure the product safety. Intraocular lenses and pacemakers are included in this category.

Because a qualified method for the manufacture and implementation of medical devices may be more variable in comparison to pharmaceutical dosage forms, it may be necessary to make clear what is (are) critical factor(s) for each device during the validation of the manufacturing process. The validation method for the medical device in each category will thus be described later.

Since the definition of validation seems to vary from nation to nation, we will include all activities from design to final product, as well as individual validation, such as process validation [2] (product qualification in ISO).

## II. PRODUCT SPECIFICATION FILES AND MEDICAL DEVICE VALIDATION IN QUALITY SYSTEMS

Establishing a quality system is required for manufacturing medical devices. The International Standards Organization [3], CFR (Code of Federal Regulations) 21 section 820 [4] for FDA, and the GHTF (Global Harmonization Task Force) [5] for medical devices are descriptive of quality systems, as shown in Table 2. Because ISO is a global organization and key player in EU market integration, GHTF was formed in 1992 in an effort to harmonize global regulatory requirements for the medical device industry by incorporating ISO standards. Furthermore, ISO has been incorporated with ANSI (American National Standards Institute), thus there are no critical differences in quality systems and validation among CFR, ISO, and GHTF. The quality system is also a key issue in achieving appropriate validation for the manufacture and quality control of medical devices. Although this section describes the validation of medical devices, it should be understood that validation is also required to achieve appropriate quality systems.

Just as preparing “product specification files” or “product justification files” may be recommended for medicine, preparing a “medical device specification file” may be recommended to achieve appropriate overall validation in a

**Table 2** Requirements of Quality System for Medical Devices

---

1. ISO/DIS 13485: The supplier shall establish, document, and maintain a quality system as a means of ensuring that product conforms to specified requirement. The supplier shall prepare a quality manual covering the requirements of ISO 9001. The quality manual shall include or make reference to the quality system procedures and outline the structure of the documentation used in the quality system.
  2. CFR21 Section 820.5 Quality System: Each manufacturer shall establish and maintain a quality system that is appropriate for the specific medical device(s) designed or manufactured, and that meets requirements of this section.
  3. Global Harmonization Task Force (GHTF), which was formed to harmonize regulatory requirements for the medical device may recommend referring to ISO 10013 for general guidance on the content of a quality manual.
-



quality system. Medical device specification files may include items described in Table 3.

The specification file may also include the development history of the product and process for manufacturing; that is, the rationale of product design and manufacturing process development are critical to assure the quality of product. The rationale for establishing the product design and manufacturing process includes the influence of the design variation on the product function and its specifications. Product function is defined as the scope and potency of disease diagnosis, medical treatment, or disease prevention with the product. Design variation, defined as an acceptance range, includes the specification range of raw materials and in-process products and the operation range of manufacturing process equipment; that is, the acceptance range of variation factors to assure that identical products are manufactured.

### **III. REGULATORY REQUIREMENTS OF VALIDATION FOR MEDICAL DEVICES**

Validation includes the design concept (design of product developed), design verification, each qualification for manufacturing, and assay/test equipment, including the establishment of a maintenance program, the development stage of manufacturing operation conditions and test methods, and individual validation (process validation and analytical method validation). Validation is thus required to ensure the establishment of product specifications, how the manufacturer maintains the quality of a product in the manufacturing process, and what factors are critical in assuring the proper functioning of the medical device. To

**Table 3** Items Included in the Medical Device Specification File to Achieve Validation

1. Design concept, design established for product, and design verification with product specification proposed.
2. Specification for raw materials, intermediate, labels, packaging materials, and finished products
3. Standard operating procedures (SOPs) for equipment operation, including maintenance, production methods, and utility and environmental specification
4. Process validation protocol and records
5. Inspection/test procedures for in-process control, product specification, and acceptance criteria
6. Sterilization process protocol and record (when needed)
7. Standard operating procedures (SOP) for assembly and servicing (including maintenance) procedures (when needed)

achieve the appropriate quality maintenance of the products manufactured, the manufacturer shall maintain GMP conditions in the written standard operation procedures (SOPs), including the maintenance program (CFR21 section 821.61 in the United States). CFR21 sections 820.72 and 820.75 state the requirements listed in Table 4, which are also required in ISO 9001 (section 4.11).

To control the manufacturing procedure adequately and to confirm the specifications of the in-process product or the final product, the manufacturing machines and measurement equipment shall be maintained to work accurately and consistently. Since accurate inspection ensures the results of test items measured by the intended equipment, the method for inspection shall always be carried out in the same manner. To ensure consistent inspection, the documented procedure shall be maintained, both with accurate inspection records and verification of the records. (See Table 4.)

**Table 4** CFR21 Section 820.72 Requirements

---

CFR21 Section 820.72 Inspection, measuring, and test equipment

820.72(a) Control of inspection, measuring, and test equipment

Each manufacturer shall ensure that all inspection, measuring, and test equipment, including mechanical, automated, or electronic inspection and test equipment, is suitable for its intended purposes and is capable of producing valid results.

1. Each manufacturer shall establish and maintain procedures to ensure that equipment is routinely calibrated, inspected, checked, and maintained.
2. The procedures shall include provisions for handling, preservation, and storage of equipment, so that its accuracy and fitness for use are maintained.
3. These activities shall be documented.

820.72(b) Calibration

Calibration procedures shall include specific directions and limits for accuracy and precision. When accuracy and precision limits are not met, there shall be provisions for remedial action to re-establish the limits and to evaluate whether there was any adverse effect on the device's quality. These activities shall be documented.

(1) Calibration standard: Calibration standards used for inspection, measuring, and test equipment shall be traceable to national or international standards.

1. If national or international standards are not practical or available, the manufacturer shall use an independent reproducible standard.
2. If no applicable standard exists, the manufacturer shall establish and maintain an in-house standard.

(2) Calibration records: The equipment identification, calibration dates, the individual performing each calibration, and the next calibration date shall be documented. These records shall be displayed on or near each piece of equipment or shall be readily available to the personnel using such equipment and to the individuals responsible for calibrating the equipment.

---

Accurate calibration of the equipment is critical to assure the manufacture of identical products. To achieve accurate calibration and to maintain the calibration adequately, periodic review of the method may be necessary based on the performance records and deviation records, as described in [Table 4](#).

Classic quality control methods normally focus on specification testing of the final product. There may be some concern about controlling the products only with the specification testing of final products (i.e., it should also be required to incorporate the in-process control parameters, such as the specification of starting material and operation condition of equipment for manufacture). These concerns include the following:

1. Whether or not the specification of the final product has been established based on its functional efficacy and safety. For example, the establishment of the specification for each item (e.g., the size of each dimension of the product and the materials used for the product) should be justified by incorporating stability information.
2. There may be more than one manufacturing method used to obtain the final product with the same specification testing results. The products manufactured in a “different” method may be similar but not always equivalent, even with satisfaction of the specification of the final product, when the specification of the final product is not established by incorporating manufacturing procedures and starting material specifications. The different manufacturing method may include a change in operational conditions, such as operation time, and a change of manufacturing site. The critical issue for process validation is how to develop the appropriate manufacturing procedure and in-process control methods scientifically and to establish the acceptance criteria.
3. According to GMP compliance, the product shall be manufactured according to the direction of the given “master record.” When deviation occurs, the acceptance criteria for the deviation may be obtained during the development stage of the manufacturing procedure; that is, although the master record gives only very limited operational conditions based on the functioning of the manufacturing equipment according to GMP requirements, the scientific data obtained in the development stage (efficiency trials described later) help to establish acceptance criteria that are broader in scope than the directions given in the master record.
4. Process validation shall be performed according to the master record and shall be evaluated according to the specification testing given in the GMP requirements. Essential factors, including the operational conditions of the manufacturing procedure and the “end point” of each step of the manufacturing procedure, should be established prior to process validation.

As shown in Table 5, where the results of a process cannot be fully verified by subsequent inspection and testing the process shall be validated. The process validation is required to assure that each process produces identical in-process product and to identify the final product by assuring that all processes are carried out in the same manner.

As described in Table 5, each manufacturer shall then establish and maintain procedures for monitoring and controlling process parameters for validated processes. To ensure that each manufacturing condition is maintained adequately, it is necessary to ensure the control parameters of the operating machinery. The control parameters should include the operation speed, operation pressure, operation temperature, and electrical current of the machinery during operation.

The acceptance criteria to manufacture product with identical quality shall be established scientifically. When change or deviation for the process occurs,

**Table 5** CFR21 Section 820.75 Requirements

---

CFR21 Section 820.75 Process Validation

820.75(a)

1. Where the results of a process cannot be fully verified by subsequent inspection and tests, the process shall be validated with a high degree of assurance and approved according to established procedures. The validation activities and results, including the date and signature of the individual(s) approving the validation and where appropriate the major equipment validated, shall be documented.
2. Examples of such processes include sterilization, aseptic processing, injection molding, and welding. The validation method must ensure that predetermined specifications are consistently met.

820.75(b)

Each manufacturer shall establish and maintain procedures for monitoring and control of process parameters for validated processes to ensure the specified requirements continue to be met.

- (1) Each manufacturer shall ensure the validated processes are performed by qualified individual(s).
- (2) For validated processes, the monitoring and control methods and data, the date performed, and, where appropriate, the individual(s) performing the process or the major equipment used shall be documented.

820.75(c)

When a change or process deviation occurs, the manufacturer shall review and evaluate the process and perform revalidation where appropriate. These activities shall be documented.

---

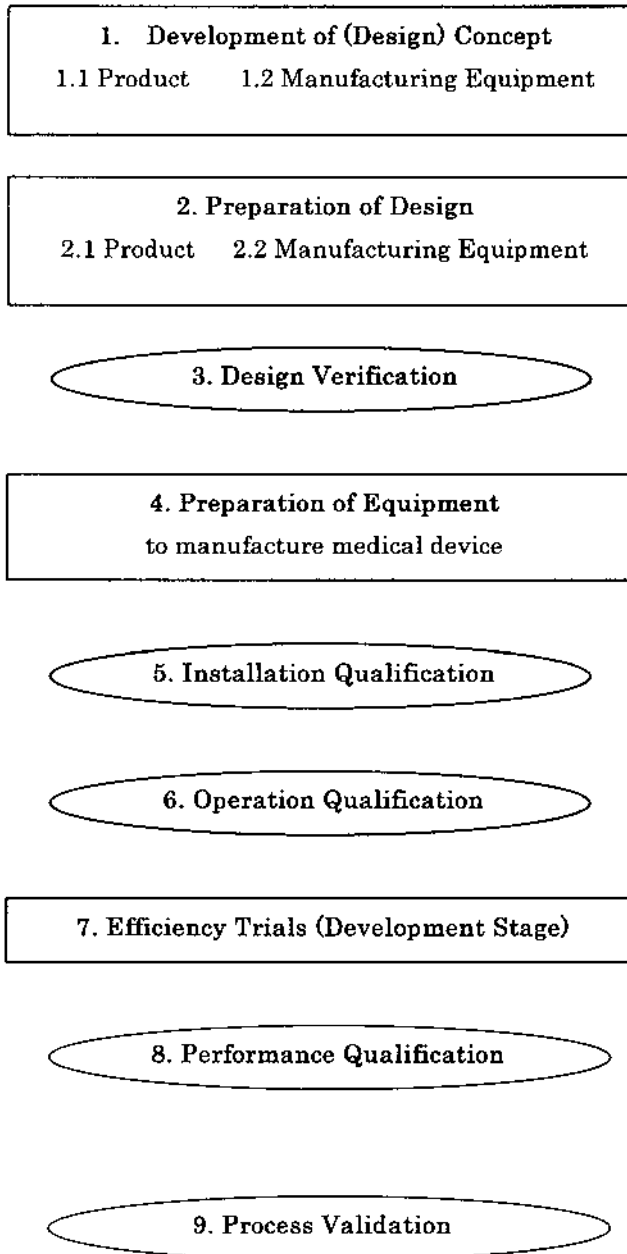
the manufacturer shall review and evaluate the process and perform revalidation, as described in [Table 5](#).

#### **IV. VALIDATION FOR MEDICAL DEVICES**

Validation is one method of assuring that the product manufactured satisfies the design required, the specification established, and the reproducibility of the results. Validation may include the items described in [Figure 1](#), although individual validation may include IQ, OQ, process validation, and analytical validation.

Items described in the [Figure 1](#) can be described as follows:

1. Development of the (design) concept, which is for both the product and the manufacturing (assembly) process and test method. The design concept for the product should include factors of function as well as safety factors. The design concept for the manufacturing (assembly) process and test method should include accuracy for manufacture and testing, and safety for preventing contamination, such as occurs from micro-organisms.
2. Preparation of design, which is for both product and the manufacturing (assembly) process and test method. Design preparation should satisfy the design concept.
3. Design verification, which is for both the product and the manufacturing (assembly) process. Design verification should reflect the design preparation.
4. Preparation of equipment for manufacture and testing, which is performed when new equipment is necessary.
5. Installation qualification (or verification with the existing line) for each processing machine, and assembly according to the processing line. Installation qualification is required to confirm that all machines and equipment are installed with all functional parts at the specific sites intended. Preventive and corrective maintenance programs should be established.
6. Operational qualification (or verification with the existing line) for each processing machine and assembled processing line. Operational qualification is required to confirm that all machines and equipment can be operated in the designed manner within the intended range. Preventive and corrective maintenance programs are established.
7. Efficiency trials, which means developing specific operational conditions of the machinery and equipment in the assembled process line to manufacture the intended product. When needed, process control parameters for monitoring and acceptance criteria must be developed.



**Figure 1** Items required for validation of medical devices. Although validation should include items 1 to 9, items 1, 2, 4, and 7 are considered to be development items.

Operational conditions and the end point must be developed to satisfy the approved specification of the products. To satisfy the developed operational conditions and end point, master records for the products and SOPs relating to processing must be developed and established with appropriate approval. The end point of this stage must be reached by establishing a master record (manufacture and specification test methods) and by producing products that satisfy the approved specification.

8. Performance qualification, which includes the equipment qualification operated under loaded conditions. Performance qualification is carried out with individual equipment based on the information obtained in efficiency trials prior to process validation under the complete assembled condition. In the case of environmental qualification and utility qualification, performance qualification is generally carried out under the operating condition for 1 year to confirm there is no deviation by season.
9. Process validation (product qualification), which is performed on each intended product, even when manufactured in the same manufacturing line. According to the master record, the manufacturing must be carried out, in-process control parameters must be monitored, and specification testing of the product must be performed. The result of specification testing must satisfy the requirements.

Validation should include verification, qualification, individual validation (process validation, computer validation, cleaning validation, analytical validation), and development stage as efficiency trials (for the establishment of processing conditions and for in-process parameters) to manufacture the intended products. Verification, qualification, and individual validation should be achieved in the protocol that includes the established method and acceptance criteria. Validation is thus classified in two categories: the development stage (rectangle) and the establishment stage (oval) based on the method shown in [Figure 1](#).

The establishment stage includes verification, qualification, and individual validation, including process validation, computer validation, method validation, and cleaning validation. These establishment stage steps shall satisfy the principal requirements in [Table 6](#).

In practical terms, the verification, qualification, analytical validation, cleaning validation, and process validation need to satisfy certain requirements.

1. The protocol must include the clarified purpose of each item, such as design verification and installation qualification. For example, the purpose of cleaning validation is to avoid any contamination.
2. The protocol shall include the established methods to perform the study and also include the acceptance criteria for the operational pa-

**Table 6** Principal Requirements for the Establishment Stage

---

1. To achieve appropriate verification, qualification, and individual validation, the method to perform shall be established and the acceptance criteria shall be clarified in the document.
  2. SOPs relating to works shall exist.
  3. Studies in the establishment stage shall be performed completely according to the method established and SOPs, and the results obtained shall satisfy the acceptance criteria required in the document.
- 

rameters (temperature, electrical current, etc.) of the equipment and in-process product specifications as well as the product specifications. When the protocol does not include the fixed operating conditions with the acceptance criteria, the study is categorized in the development stage rather than the qualification stage.

3. The study shall be carried out according to the method described in the protocol. When the method used in the study deviates from the protocol, it shall be shown that the method used is equivalent to the method in the protocol.
4. All operating conditions and in-process parameters must be recorded.
5. The quality control testing of the final product must be performed and the results must be recorded.
6. The results obtained shall satisfy the criteria of the operating parameters and the specifications of the in-process products as well as the final product.
7. The written study report shall be prepared.
8. The documents shall be verified, approved, and filed; the necessary documents are protocol, records for operation, in-process control parameters, specification test as quality control, and final report.

Studying the development stage works (design steps and efficiency trials steps) is necessary for designing the product; for designing the processing line of the product and the assembly flow of the product; for determining the processing conditions, including the end point of each processing step; for determining the assembly method; for determining product specification; for determining the product specification test method; and for establishing SOPs. Development stage works must satisfy the following:

1. The protocol must include the product concept as well as the purpose. The product concept must be comprehensively simplified for designing the next step and should describe the effective role of the



medical device against the disease. For example, when developing daily soft contact lenses, recovery of eyesight, cleanliness of the eye by using disposable lenses, and low cost to satisfy disposability are included in the product concept.

2. The protocol must include development of the design of in-process product as well as the design of final product based on the product concept. A program should thus be included to confirm that the design of the product satisfies the product concept. This program will be performed by using a checklist that includes the items for the product concept, such as the size, shape, and nature of the materials.
3. The protocol must include the proposed tentative specifications of the in-process product with the acceptance criteria and directs the finalization of the specification at the end of the development stage. The specification should be proposed based upon the product design; that is, the specification includes the size, shape, impurities, and nature of the materials, such as viscosity and tension. Developing the specifications of the final product and parts for assembly must be performed to specify the product efficacy and product liability based on the design concept and scientific data, such as stability data.
4. The protocol must include the proposed tentative manufacturing procedure that will be fixed at the end of the development stage. The tentative manufacturing procedure includes what kind of manufacturing equipment will be used, how the manufacturing equipment will be assembled, and how to operate the equipment. The operational condition of the equipment will be fixed at the end of the development stage.
5. The protocol must include directions on selecting or developing the maintenance program, including preventive and corrective action. The maintenance program includes the calibration program of measurement equipment and the replacement of equipment parts.
6. The study shall be carried out according to the method described in the protocol. When the method used in the study is changed from the protocol, it shall be justified in the document according to the established change control system. In general, however, the acceptance criteria of the specifications for the final product should not be changed without specific data relating to safety and functional assessment.
7. All operating conditions and in-process parameters must be recorded. This is important to provide the scientific and/or statistic rationale to fix the operating conditions at the end of the development stage.
8. The specification testing of products that are manufactured in the trial run and stored according to the proposed conditions must be

documented, because all information is necessary to finalize the specification of the products.

9. The results obtained for the specification testing shall satisfy the acceptance criteria that assure the efficacy and safety of the product.
10. The study report shall be prepared as “development of product” in a written document.
11. The documents shall be verified, approved, and filed; essential documents are the protocol, records for operation, in-process control parameters, change control document, specification test as quality control, and final report.

## **V. APPROACHES FOR VERIFICATION, QUALIFICATION, AND PROCESS VALIDATION FOR MEDICAL DEVICES**

In the beginning it should be clear what the key issues are for verification, qualification, and process validation. Such issues are listed in Table 7.

Validation in quality systems includes establishment of procedures on how to qualify the equipment and machinery, how to verify the design of products, how to verify the process designed, how to verify the achievement of production procedures, how to validate the process developed, and how to validate the methods for measurement and assay. Validation also requires verification of specifications or acceptance criteria of in-process parameters relating to both raw materials and intermediate (in-process product) and finished products, and verification of acceptance criteria for in-process parameters relating to operating conditions of machinery and equipment. Further, when the medical device is assembled at the user’s site, validation includes establishing procedures of how to verify assembly.

Preparing a master project plan is useful to achieve appropriate verification, qualification, and individual validation. According to the directions of the master project plan, protocol is generated, the study or test is performed, and the report is prepared. Of course, each protocol, performance record, and report must be reviewed and approved appropriately. The master project plan may

**Table 7** Key Issues for Qualification, Verification, and Individual Validation

---

Acceptance criteria must be key to achieve appropriate qualification, verification, and individual validation. Acceptance criteria may consist of various specifications of intermediate and finished products for medical devices. Acceptance criteria also may control parameters for operation of processing equipment and utilities used.

---

include the items described in Table 8, section 1. The protocol required in the master project plan includes the items described in Table 8, section 2.

The object (item a) in the master project plan provides the purpose of the project, including the event achieved and the role of the project plan. The scope (item a) provides the applied items, including the product, facility, and equipment for manufacture, and the manufacturing process, including the sterilization process when needed, the measurement equipment, and/or the test method. Item b requires who is in charge of each item and what kind of role he or she has. In item c, the expected events in [Figure 1](#) and the definition of each event are described. Design verification of product, for example, requires a comparison of the document for the product design concept with the design drawing/formulation of the product. It also requires recording the document number for the product design concept and the design drawing/formulation. Criteria (item d) include the necessity of each event, such as verification, qualification, and validation. The criteria also include the method of creating the acceptance criteria. Acceptance criteria may sometimes be described in the protocol, because the

**Table 8** Items Included and Protocol Indicated in the Master Project Plan

---

1. Items included in the master project plan
    - a. Object and scope
    - b. Responsibility for project
    - c. Content and type of qualification, verification, or validation
    - d. Criteria for qualification, verification, or validation
    - e. Protocol required in the project
    - f. SOPs that must be developed and established
    - g. Maintenance program (preventive and corrective)
    - h. Estimated period for achievement
    - i. Compliance
    - j. Change control
    - k. Approval
  2. Protocol indicated in the master project plan
    - a. Verification of design
    - b. Installation qualification and operational qualification
    - c. Development of procedure, measurement, or assay
    - d. Performance qualification
    - e. Process validation
    - f. Measurement validation and verification
    - g. Assay validation
    - h. Verification of specification established
    - i. Generation and verification of assemble procedure at user's site
-

project plan for a new product may be prepared prior to the completion of design verification. The criteria are important to complete risk assessments. The project plan should describe what kind of protocol is required to complete the project plan. The protocol (item e) required in the validation is described in [Table 8](#), section 2. Item f in [Table 8](#), section 1 expects that SOPs will be established to manufacture products. The maintenance program (item g) is required to keep the quality of the product manufactured by maintaining the equipment for manufacture and measurement. Item h indicates the estimated project duration with the starting date and the target date for completion. Item i indicates how all documents are reviewed and revised. The change control (item 10) is necessary to perform an appropriate change of method and the acceptance criteria for each event. The change control requires that the change should be carried out in the established system. Item k indicates that all actions and documents must be approved.

The protocol shall include adequate content in the same manner as the master project plan described in [Table 8](#), section 1. The methods used should be described in detail. The content of the protocol leads us to perform the essential items completely and evaluate the items scientifically and statistically.

## **VI. AN APPROACH TO THE VALIDATION OF MEDICAL DEVICES AND CRITICAL ISSUES IN EACH STEP OF THE PROCESS**

Validation of the medical device is generally developed according to the steps shown in [Figure 2](#).

1. A critical issue in the development stage in step 1 is that the concept of the product developed should satisfy functional and safety aspects to achieve the expected treatment effectively. When the concept is developed, it must be reviewed based upon risk assessment. One of important issues in step 1 is to establish whether the device will be sterile or not.
2. A critical issue in the design of the product in step 2 is that the design must satisfy the concepts for the product being developed. Physical and chemical designs of the product are developed by means of drawings and materials used to display the function of the product, and the tentative specification of the designed product is developed. The chemical design should include the materials used and formulation compositions when mixed, and reflect the biocompatibility when the product is in the plant. The specification developed must be based on the function designed and other physicochemical properties. The de-

1. Concept of Product	*Concept of products should include whether products are used in sterilized condition.
2. Design of Product with the tentative specification and design of process lines	*When the products are used in sterilized condition design of materials of products and selection of sterilization should be included.
3. Design Verification	*When sterilization process should be included, the selection of material and the process should be verified from the point of physical and microbiological integrity of product.
4. Establishment of process line to manufacture product	*It should be established whether use of terminal sterilization or in-process sterilization with aseptic operation. When terminal sterilization is adapted for medical devices ISO standard listed in references shall be referred.
5. IQ/OQ	*When the sterilization process is included, it may be recommended to use ISO requirements standard listed in the references for medical devices
6. Efficiency trails to develop in-process parameter	*Regarding sterilization process, in-process parameter should be developed to satisfy physical and microbiological criteria.
7. Performance qualification and Process validation	*When sterilization process is included. ISO requires performing the qualification in the worst case (product qualification).

**Figure 2** Items required for overall validation. Although validation is required for all items, items 1, 2, 4, and 6 are considered to be development items.

sign thus should include drawings of the product, its acceptance range, and the material to be used and its specifications. When products need to be supplied as sterile products or are to be used after sterilization, the selection of the material and sterilization methods are included; that is, the selection of the sterilization method should be carried out based on maintaining chemical and physical stability of the materials. It is also important to clarify whether the use of a terminal sterilization method is acceptable or not. When the terminal sterilization method is not acceptable because of low resistance of the materials to the heat or other sterilization method, aseptic processing should be designed. Further, elements of the sterilization method (e.g., equipment, operating temperature, operating pressure, and operating time) should be described in detail for the user when the product is required to be sterilized prior to use in the user site.

3. The critical issue in design verification in step 3 (verification stage) is that the protocol must include both the established method to verify and the acceptance criteria. The established method in this step may be an evaluation checklist that includes the essential items based on the concept, such as shape, size, and materials. For example, in the case of the development of hydrophilic interlobular lenses (IOL), the checklist includes biocompatible materials with polymer mixture compositions for hydrophilic nature and the kind of diopter developed. The selection of the polymer mixture should also be considered in the molding method. The critical issue for acceptance criteria in the protocol is that the specification satisfies the function, such as diopter for IOL, and the safety of the product designed, such as the biocompatibility of IOL material. The acceptance criteria are established based on the acceptance range of drawings and material specifications. The verification of the applied sterilization process is also carried out based on the scientific evidence with no decay of materials by sterilization. For example, because the biocompatible materials for IOL may not be stable against the terminal heat sterilization, it should be verified that the terminal sterilization using ethylenoxide gas will be applied with aeration time to minimize residual gas.
4. In step 4, the development stage, in establishing a process to manufacture the product (designed in step 2) the critical issue is to select an appropriate manufacturing process with appropriate equipment. Developing the manufacturing flow includes what kind of equipment will be used for each step. The process developed in this step may also include in-process monitoring items, such as a process to verify the in-process product in the subsequent inspection (test) and a method to monitor the sterilizing condition.

5. In step 5, the qualification stage, the critical issue is that the protocol for IQ/OQ of the equipment and the facility include the established method and acceptance criteria. The IQ/OQ report should include the maintenance program to keep the equipment in good condition for reproducibility of the product. For qualification of the equipment and process for terminal sterilization, the following standards should be referred to: ISO 13408-1 [6] and 11138-1 [7] for general issues, ISO 11134 [8] and 11138-3 [9] for moist heat sterilization, ISO 11135 [10] and 11138-2 [11] for ethylene oxide sterilization, and ISO 11137 [12] for radiation sterilization.
6. In step 6, the development stage, the critical issue is that appropriate operating conditions with in-process monitoring parameters must be developed for efficiency trials. In this step, master record and in-process monitoring parameters must be developed; that is, the proposed master record and SOPs relating to manufacture should be prepared in the report. For the sterilization process, developing in-process parameters should be carried out based on the following two aspects: (1) physical performance and (2) microbiological performance with ISO 11737-1 [13] and 11737-2 [14]. Further, the worst case in the process shall be established to move to process validation (products qualification) in ISO 13408-1.
7. In step 7, the validation stage, the critical issue is that the protocol for performance qualification (utility and environmental conditions that relate to all products) and process validation (relating only to the individual product) should include the master record (including in-process control monitoring parameters) and acceptance criteria (including product specification and operation acceptance range). (In ISO 11385, the process validation described in CFR21. 820 shall be divided in two categories, such as performance qualification and product qualification. Performance qualification is same as process validation in CFR, and product qualification is defined to qualify the process in the worst case.) The master record and acceptance criteria should be based on the report of the efficiency trial and approved by QA.

In general, medical devices may be categorized primarily into three types, in terms of quality control, as described in [Table 9](#).

In type 1, process verification is required because of subsequent functional specifications for all products. Surgical equipment, such as scissors and tweezers, contact lenses, and eyeglasses are categorized type 1a. Diagnostic equipment, such as CT scanners, and treatment equipment, such as infusion pumps for the introduction of solution types of medicine and surgical aid solutions are categorized as type 1b. In b, instructions for assembly at the user's site should be

**Table 9** Categories of Medical Devices Based on Quality Control Testing

---

1. Type 1: The product does not comprise a batch, and functional specification tests are performed for each product. In type 1a, the specification test of the finished product should be performed prior to the release from manufacturer. In type 1b, because the product is finished with in-process products by assembling at the user site, the specification test of each in-process product should be performed prior to the release from manufacturer and the specification test of the finished product should be performed at user site.
2. Type 2: The product comprises a batch and functional specification tests are performed with representatives of each batch prior to the release from manufacturer.
3. Type 3: In-process product does not comprise a batch, as in type 1, and functional tests are performed for each in-process product. However, when put together in the specific process such as sterilization process, the specification test is performed with representative of the finished products.

“Comprising a batch” means that products are manufactured in one controlled condition from starting materials to finished product such as ophthalmic irrigating solution in vial form. A product that does not comprise a batch is manufactured individually, such as eyeglasses.

---

in the document. Some products of type 1a are designed for individual patients, according to the specifications in diagnosis, and design verification and development of direct in-process product parameters are thus critical factors. With products of type 1b, development of operating procedures to perform consistently, is also included as critical-factor because of the necessity of adequate diagnosis and treatment.

In case of type 2, process validation is required because of subsequent specifications not being tested; that is, the specification test is done with representatives in the batch. In this type, viscosurgical solutions not including pharmacological agents, central venous catheters and other surgical tubing, and surgical thread are categorized. The process of development and validation for manufacturing this type are the same as for medicine composed in batches, such as intravenous injection solution. Product that is not specifically for an individual patient is designed to apply to all patients. In general, manufacturing processes for many products in this category are performed continuously. Monitoring only the operating conditions of the machinery and equipment that manufacture the product and the end point of each process is established with operating conditions such as operating time, temperature, pressure, and stirring speed; that is, the end point of each process does not include the specifications of the in-process product. Finally, only the specifications of the finished product are tested.

In the case of type 3, process verification is required to produce the in-process product as type 1, but process validation is required to manufacture the



finished product as type 2. In this type, intraocular lenses and surgical equipment needing sterilization are categorized; that is, sterilization is performed by composing batch and development and validation of indirect, in-process parameters and this process is critical.

In the above situation it must be assured that each process can produce in-process product with the intended specifications, even without an in-process product specification test, by monitoring operating conditions of the machinery and terminating the process with the intended end point of operating the machine. Briefly, the establishment of an end point of each process only with operating conditions must assure that in-process product in each process meet the intended specification. It may thus be important that the end point of each process must be established by testing the in-process product specified properties in the development step; that is, the end point of each process must be determined based on the specified properties scientifically, which must be a critical factor for the specified properties of finished product. Validation is required to assure that the operating conditions including the end point of each process, can produce appropriate in-process product, satisfying critical specified properties in each step without in-process product specification tests; that is, it may be that validation is required in order to omit the in-process product specification test.

One example for type 3 in [Table 9](#) is the intraocular lens (IOLs), and the validation may be performed as follows according to [Figure 2](#).

Because IOL is implanted, ISO 11979-2 [15] and 11979-3 [16] for IOL describe the standards of the specifications for physicochemical, microbiological, and tissue compatibility, along with the requirements for preclinical safety study and clinical study and packaging. Based on the specifications in ISO 11979-2 and 11979-3, the design of IOL, including such elements as shape and diopter, is restricted by registration and administrative approval. The following steps are thus considered for validation for IOL manufacture:

1. Document of material specifications and test methods. Verification of the specifications must be done to satisfy the design, and the test method must be validated where needed. Because the material is a critical safety factor, the selection of material for IOL should meet both the physicochemical and compatibility specifications described in ISO 11979-2 and 11979-3. The in-house (receiving) specifications of material should thus be documented. Where a test method is developed, the method must be validated. The equipment used for the test must be calibrated.
2. Document of specifications of IOL with shape and diopter. Verification of specifications must be done to assure the design has been followed. Because shape and diopter are critical functional factors for IOL and should be registered by administrative approval, the design

should be established in the document. Where the test method is developed, the method must be validated. The equipment used for testing must be calibrated.

3. Master record for manufacture. The master record must include the method to test the functional factor, and the process that includes in-process product testing must be validated. Master records should include all operations in manufacturing IOL in detail. Critical steps for manufacturing IOL should be a cutting/polishing step or molding step for shape, a grinding and polishing step for diopter, and a sterilization step.
  - a. The process that relates to the shape and diopter of IOL must be controlled individually by in-process tests, including measurement; that is, because the product is not composed in batches, a manufacturing record exists for the individual product. This process must thus be verified for each product by the method of a double-check. Where the manufacturer develops the test method, the method must be validated. The equipment used for testing must be calibrated.
  - b. The process for sterilization, is a critical step for safety, and should be performed for IOL in the batch unit. Because the sterilization process cannot be fully verified by subsequent inspection and testing for each product, this process must be validated using both chemical and biological indicators to establish the operating conditions recorded in operating monitoring parameters.

## VII. RISK ASSESSMENT FOR VALIDATION

Because validation is required to establish the quality of the medical device, including reproducibility, each process shall undergo risk assessment. Risk assessment includes two criteria: (1) how the process can avoid the appearance of rejected goods or other unsatisfactory goods in each process, and (2) how the in-process parameters, including in-process product specification, can detect goods to be rejected or otherwise unsatisfactory goods. Risk assessment for medical devices is thus required to provide satisfactory goods to customers by controlling the manufacturing process and by testing in-process product as well as final product.

## REFERENCES

1. ISO 13485. Quality Systems—Medical Devices: Particular Requirement for the Application of ISO 9001. Switzerland (1997).
2. U.S. Food and Drug Administration. Guidance on General Principles of Process Validation. (1987).

3. ISO 9001. Quality System—Model for Quality Assurance in Design, Development, Production, Installation and Servicing. Switzerland (1994).
4. Code of Federal Regulations (CFR), Title 21. Part 820.5: Quality Assurance Program; Part 820.20(a): Quality Assurance Program Requirements. Washington, DC: U.S. Government Printing Office (1996).
5. Global Harmonization Task Force. Guidance on Quality Systems for the Design and Manufacture of Medical Devices. (1994).
6. ISO 13408-1. Aseptic Processing of Health Care Products—Part 1: General Requirements. Switzerland (1996).
7. ISO 11134. Sterilization of Health Care Products—Requirements for Validation and Routine Control—Industrial Moist Heat Sterilization. Switzerland (1998).
8. ISO 11138-1. Sterilization of Health Care Products—Biological Indicators. Switzerland (1998).
9. ISO 11138-3. Sterilization of Health Care Products—Biological Indicators Part 2: Biological Indicators for Moist Heat Sterilization. Switzerland (1998).
10. ISO 11135. Sterilization of Health Care Products—Requirements for Validation and Routine Control of Ethylene Oxide Sterilization. Switzerland (1998).
11. ISO 11138-2. Sterilization of Health Care Products—Biological Indicators Part 2: Biological Indicators for Ethylene Oxides Sterilization. Switzerland (1998).
12. ISO 11137. Sterilization of Health Care Products—Requirements for Validation and Routine Control—Radiation Sterilization. Switzerland (1998).
13. ISO 11737-1. Sterilization of Medical Devices, Microbiological Methods—Part 1: Estimation of Population of Microorganisms on Products. Switzerland (1998).
14. ISO 11737-2. Sterilization of Medical Devices. Microbiological Indicators—Part 2: Tests of Sterility Performed in the Validation of a Sterilization Process. Switzerland (1998).
15. ISO 11979-2. Ophthalmic Implants—Intraocular Lens—Part 2: Optical Properties and Their Test Methods. Switzerland (1999).
16. ISO 11979-3. Ophthalmic Implants—Intraocular Lens—Part 3: Mechanical Properties and Their Test Methods. Switzerland (1999).

# 7

## Validation of Biotechnology Processes

**Gail Sofer**

*BioReliance, Rockville, Maryland, U.S.A.*

### I. INTRODUCTION

Validation of biotechnology processes is generally more complex than validation of more traditional synthetic or naturally occurring small molecule drugs. The level of complexity depends on the type of biotechnology product. Biotechnology products range from synthetic oligonucleotides and peptides to plasmids, recombinant-DNA-derived and transgenic proteins, monoclonal antibodies, gene therapy vectors, and some cell-based therapies. The more complex the product, the more difficult validation becomes. The degree of difficulty is usually linked to an inability to fully characterize the product and the manufacturing process. For example, one of the most complex products is human cells treated with a gene therapy vector or protein and delivered to the patient. Other factors that contribute to the complexity are the known or unknown risks associated with some of the sources of biotechnology products. In spite of the diverse range of biotechnology products, however, there are some commonalities in validation of the manufacturing processes. There are, in fact, many validation issues that are identical to those associated with traditional pharmaceutical products, including facility and equipment qualification, validation of water and aseptic processing systems, and computer validation. These topics are addressed elsewhere in this book.

Before a biotechnology process can be validated, it is essential to evaluate the inherent risk factors associated with the product source, raw materials, and processing operations. Furthermore, the analytical methods that allow characterization and validation of the process, as well as characterization of raw materi-

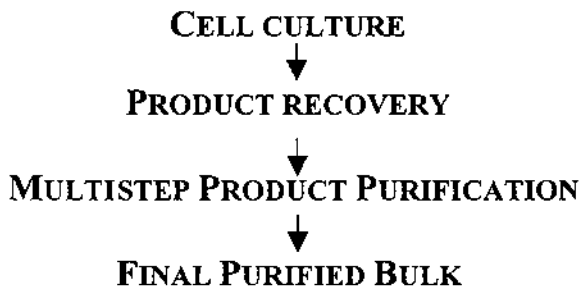
als, process intermediates, and final product, must be validated. For plasmids, recombinant-DNA-derived proteins, monoclonal antibodies, and gene therapy vectors, manufacturing unit operations generally start with fermentation or cell culture, which is followed by product recovery and subsequent purification by multiple steps to produce the purified bulk. A flow scheme for a typical biotechnology process is shown in Figure 1, and Figure 2 illustrates the process flow for production of a monoclonal antibody. This chapter discusses the risk factors that must be addressed during validation, the analytical tools necessary for validation, the validation of the unit operations employed in typical biotechnology processes, the timing of validation-related activities, and current and future issues in validation of biotechnology processes.

## II. RISK FACTORS

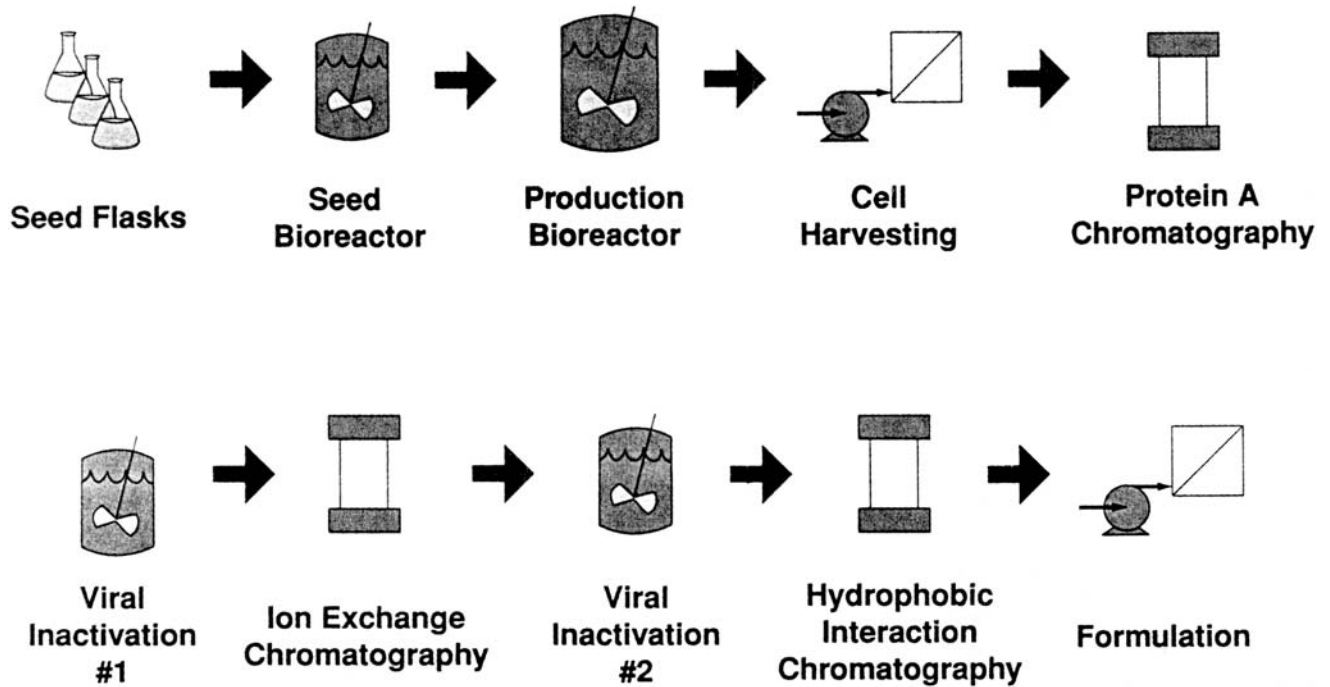
Validation starts with good process design, which permits reduction of the risk factors to an acceptable level. Once the process is well characterized it can be validated. It is essential to know where in the process the risk factors are removed and how much risk will be incurred if a manufacturing deviation occurs. Process validation provides such information.

### A. Product Sources and Raw Materials

Most of today's approved biotechnology products are produced in bacteria, yeast, or mammalian cells. Newer sources currently used to manufacture clinical trial materials include insect cells, transgenic animals, and gene therapy vectors. Other potential sources include transgenic plants and nonviral delivery systems



**Figure 1** Flow scheme for production of a recombinant DNA-derived protein produced in mammalian cells.



**Figure 2** Process flow diagram for production of a monoclonal antibody. (From Ref. 47.)

for gene therapy. Each of these poses unique risks—both known and potentially unknown. Table 1 summarizes some of the known risks associated with several commonly used sources. In addition to the source material, raw materials used in establishing cell banks, in fermentation or cell culture, and in processing may add to the complexity of validation. For example, animal sera are often employed to enable cells to grow in culture and to stabilize them in storage. Commonly used porcine and bovine products have the potential to transmit viruses to the cells, and bovine products may be contaminated with transmissible spongiform encephalopathies (TSEs; e.g., bovine spongiform encephalopathy, BSE). In some cases, the potential risk factors listed in Table 1 are associated with raw materials.

Bacteria and yeast pose no known risks that are associated with viruses and TSEs. Provided raw materials are free from these agents, validation can proceed without considering viral and TSE clearance. Insect cells grow at lower temperatures than mammalian cells, yet it has been shown that viruses known to infect humans can be maintained in an insect culture [1]. As of this writing there are no licensed therapeutic products produced in insect cells, so the requirements are not yet well defined. It appears, however, that most firms perform viral clearance studies prior to submitting a biologics licensing application (BLA). Mammalian cells, on the other hand, have been shown to harbor viruses known to infect humans. Transgenic animals, such as goats or cows, may harbor infectious viruses and even TSEs that have the potential to be copurified with the product. Gene therapy viral vectors currently in clinical trials include retroviruses and adenoviruses, which also can infect humans. Allogeneic cellular bio-

**Table 1** Potential Sources of Biotech Materials and Their Associated Risks

Potential risks	Bacteria	Yeast	Insect cells	Mammalian cells	Transgenic animals	Gene therapy viral vectors	Cellular and gene therapy combination
Virus	–	–	+	+	+	+	+
TSEs <sup>a</sup>	–	–	+/-	+/-	+	+/-	+/-
Endotoxin	+	–	–	–	–	–	–
Nucleic acid	+	+	+	+	+	+	+
Proteins	+	+	+	+	+	+	+

<sup>a</sup>With the exception of transgenic animals, the risk is generally associated with animal-derived products used in cell culture and other processing steps.

Note: +Potential risk, –no known associated risk, +/-risk from TSEs potentially associated with animal-derived product used in processing.

technology products probably present the greatest viral risk since the donor cells as well as the manipulation (e.g., with viral vectors) performed on them may lead to introduction of infectious virus into the patient.

Endotoxins are found in some bacterial sources, such as *E. coli*. For other products they are considered a contaminant that should not be present and can be controlled by adherence to good manufacturing practices (GMPs). Nucleic acids, once considered a significant risk, are now thought of as cellular impurities, and their removal should be validated [2,3]. Proteins that pose a potential risk (e.g., immunogenicity) include host cell proteins, aberrant protein product, proteins used in cell culture, and those associated with the process (e.g., protein A affinity ligands or nucleases employed to reduce viscosity).

## **B. Processing Risks**

Variability in cell culture may lead to unexpected expression of an adventitious agent. Proteolytic degradation and aggregation may result in aberrant product forms that change potency or are immunogenic. During recovery and purification operations, variability in processing materials may lead to changes in product quality. Leachables from chromatographic resins, filters, and equipment components may be toxic and/or immunogenic. Buildup of contaminants may occur, with the potential for an unexpected release into the product stream. All of these risks can be countered by putting into place raw materials' screening and acceptance criteria, by designing robust processes that can clear known and potential unknown risks, by establishing realistic specifications for controlling each unit operation, by employing suitable validated analytical methods for analyzing processes, and by adhering to CGMPs to avoid contamination.

## **III. ANALYSIS AND THE CONCEPT OF WELL-CHARACTERIZED BIOTECHNOLOGY PRODUCTS**

Before the process can be validated, it is essential to validate the analytical methods that provide the data that enable processes to be understood and controlled. Although the same is true for small molecules and other drugs, the task of analyzing most biotechnology processes and products is generally more complex [4]. The most frequently employed analytical methods are listed in [Table 2](#). Peptide mapping has been widely used to demonstrate a difference of only one amino acid between a protein product and an aberrant form. The use of mass spectrometry has increased greatly over the last few years and provides information on molecular weight of intact product as well as identification of impurities by mass. In combination with other techniques, such as peptide map-



**Table 2** Frequently Employed Analytical Methods for Process Validation

Methods	Detection
Peptide mapping	Impurities
Mass spectrometry	Purity and impurities, molecular weight, glycosylation
HPLC	Purity, impurities, carbohydrate analysis
Electrophoresis	Purity, impurities, glycoforms
Bioassays	Potency, tertiary structure
Western blot	Protein impurities
Carbohydrate analysis	Glycoforms, carbohydrate sequence
PCR	DNA, viruses, mycoplasma
Nucleic acid sequencing	Genetic stability

PCR, polymerase chain reaction.

ping, mass spectrometry can confirm primary structure and posttranslational modifications, such as glycosylation. The use of tandem-mass spectrometry for rapid identification of proteins was reviewed by Dongre et al [5]. Ion exchange and reverse-phase high performance liquid chromatography (HPLC) are employed for both in-process and product assays and for carbohydrate analysis. Size-exclusion HPLC enables assessment of aggregates. Stability-indicating assays are also essential for intermediates and final product. Further information on stability testing is provided by the International Conference on Harmonization (ICH), and some of the analytical methods currently employed are discussed by Reubsæet et al. [6,7]. A 1995 review discusses the major pathways of protein degradation [8].

Bioassays may be the most important assays since they are often the only available tools for determining the correct tertiary structure of complex protein products and the activity of even more complex biotechnology products. Bioassays are also the most problematic assays, and the variability may be 50% for animal-based bioassays. New developments in sensor technologies may improve both the speed and accuracy of bioassays [9]. The development of hematopoietic stem cells for in vitro assays has the potential to increase both the accuracy and the speed of bioassays [10].

Another complex assay is the host cell protein assay, which can take more than a year to develop and usually requires that culture conditions be established at least at a pilot scale [11,12]. Host cell proteins may vary with the culture conditions, including scale of operation. As a result, the panel of antibodies generated against host cell proteins will need to be generated against host cell proteins expressed under controlled conditions used for manufacturing of pilot or full-scale supplies. Conditions are usually not established until phase III clinical trials, however, and this leads to significant timing problems in many cases.

The inability to pick up all host cell proteins is another problem faced in development and implementation of these assays.

For firms that manufacture several products from one source (e.g., Chinese hamster ovary [CHO] cells), a generic approach may suffice. Regulatory authorities in some countries are accepting this approach [13]. There are also some generic kits on the market that can be used to study host cell protein clearance during development, and may be considered acceptable for licensure.

Other assays that are required include those employed for cleaning validation, sterility, bioburden, and mycoplasma. Cleaning validation for biotechnology processes is described in a PDA publication [14].

It has been stated that “characterization is often technology challenged” [15]. Using a combination of orthogonal analytical methods does, however, enable the characterization of biotechnology processes and products. In the past, the processes used to produce them defined biological products. While this may still be true for complex vaccines, some blood products, viral vectors, and cell therapies, many biotechnology products are considered well characterized. It is difficult to define exactly what well characterized means for all biotechnology products. To allow for rapid implementation of newer analytical methods as they are developed, the U.S. FDA dropped the term well characterized as an official classification of biotechnology products. Instead, the term *specified* was applied to therapeutic plasmids, therapeutic synthetic peptides of 40 or fewer amino acids, therapeutic monoclonal antibodies, and therapeutic proteins produced by recombinant DNA technology [16]. Most of the information that follows applies to these products, particularly the latter two.

#### IV. UNIT OPERATIONS

Fermentation and cell culture provide the necessary quantities of starting material. Following the growth of the cells to the requisite quantities, the product is recovered and then purified. For each unit operation there are some specific validation issues that may be discussed. Some common features apply to all of these manufacturing steps, however. The processing times for each unit operation must be defined and the process validated within established time limits. Biological products are usually much more labile than traditional drug products and validation of stability is essential. Often the conditions that maintain product and intermediate stability are ideal for the growth of micro-organisms. Even if the micro-organisms are removed, they may potentially leave behind toxins and other harmful substances that can cause product degradation or copurify with a protein or nucleic acid product. Temperature, pH, conductivity, product concentration, presence of impurities (e.g., proteases in the initial feedstream), process-

ing times, and product concentration may all affect stability, which must be validated for in-process intermediates, final bulk, and final product.

Bioburden and endotoxin specifications should be established and adhered to for each step. Holding times between steps and prior to cleaning must be kept within predetermined specifications. Cleaning validation is another concern that many biotechnology firms must address for each unit operation. This can be particularly problematic for the manufacture of material made in small quantities in facilities in which more than one product is produced. Although the biotechnology industry now has access to equipment that is of a sanitary design for pilot and full-scale manufacturing, this is not always the case at smaller batch sizes, such as those often used to produce clinical supplies or even for some high-potency, small-dosage products. For example, chromatography systems for small-scale batches often have threaded fittings, which make both cleaning and sanitization difficult.

During development, control parameters are optimized for each unit operation. During the preparation of the validation batches (i.e., three to five consistency batches at pilot or full scale, generally during phase III pivotal clinical trials), the control parameters are tested by determining the outputs under worst-case conditions. With biotechnology processes, the variables clearly impact one another. For example, a change in pH may impact the required conductivity range that enables production of the desired product. Multifactorial analysis is often used to minimize the number of runs that must be performed during validation of modern biotechnology processes [17]. There are many approaches to process validation and there are some who advocate testing all parameters to the edge of failure. This approach can be very costly. Others in the biotechnology industry advocate only testing to the edge of failure those parameters likely to cause variability. For example, temperature can be rigorously controlled within a very narrow range. In designing validation studies, it is cost-effective to maintain this control and avoid pushing the process to fail at temperatures outside the specified range.

## **A. Cell Culture**

Cell culture is the first production step for a typical biotechnology product made in eucaryotes (organisms that contain a nucleus and membrane-bound organelles). Chinese hamster ovary cell lines are one of the more commonly used sources for production of recombinant DNA-derived proteins, and will be used here to illustrate some of the common validation issues. The culturing process cannot be validated without first defining raw materials and characterizing the cells [18,19]. A master cell bank (MCB) and a working cell bank (WCB) are prepared and characterized. In addition to testing the cell banks, cells are tested at the end of production and the unprocessed bulk is also tested. The history of

the cell line, including potential previous exposure to animal and human substances, is documented. Depending upon what is known about the source and the history of the cells, a testing program is designed and implemented. It should follow the latest regulatory guidances [20]. In the case of CHO cells, cell line characterization includes determining if the cells are truly what they are thought to be. Isoenzyme analysis is commonly used. Banding cytogenetics provides the most sensitive identity test, with the capability to detect an impurity of 1% [21]. Testing also requires the use of validated assays for detecting mycoplasma, bacteria, fungi, and viral contamination. Cells are tested for the presence of both endogenous and adventitious virus. Cells such as CHO cells are known to have retroviral particles. Electron microscopy has historically been used to determine the retroviral particle load, and has the added advantage of being able to detect other viruses. Today, polymerase chain reaction (PCR) is also being used. During process validation the ability of the process to remove retroviral particles to a level beyond the maximum that could be found in the unprocessed bulk material is validated.

The optimal conditions are determined during development of the culture. Control parameters that provide cell viability, sufficient quantity of viable product, and an unprocessed bulk that can be purified to the requisite level are evaluated in development. The kinetics of cell growth, product formation rate, and total product yield are evaluated. The ability to maintain sterility during sampling of the bioreactor is validated. Realistic ranges are set for all of the control parameters, which include in addition to time, dissolved oxygen, temperature, pH, and motor speed. Measurable outputs include cell density and viability, product content and quality, and the absence of bioburden. (See Table 3.) Prior to validation, the bioreactor scale is generally increased. In some cases, 1-L bioreactors used in development are scaled up to tens of thousands of liters to meet production needs. As with any scale change, this may alter the acceptable ranges of the critical control parameters. Of all the unit operations for a biotechnology process, cell culture is usually the most variable. Cells may be suscepti-

**Table 3** Some Operating Variables and Acceptance Criteria for Cell Culture Operations

Operating variables:	Acceptance criteria:
pH	Product content
Dissolved oxygen	Product quality
Temperature	Cell viability
Motor speed	Cell density
	Bioburden

ble to slight variability in the operating parameters, and when the scale is changed, the control over pH, temperature, and dissolved oxygen must be maintained. Another factor is the ability to stir the bioreactor at a larger scale without shearing the cells if the mechanism of stirring changes with the scale change. Furthermore, the cells may die at different times, resulting in variable protein impurities and product quality changes that make validation of downstream processing even more challenging. Changes in scale as well as cell culture media quality can result in major changes in protein products. If changes in posttranslational modifications such as glycosylation occur, product potency and immunogenicity may be altered. Relevant assays must be used in validation to detect changes, and if changes are observed it may be necessary to re-evaluate product potency, efficacy, and safety.

In spite of the potential for changes described above, varying scale and operating conditions for a monoclonal antibody had little impact in one study that evaluated the effects of extending population doublings, low glucose, and harvest times outside normal manufacturing ranges. The glycosylation pattern only changed during the early stages of the bioreactor culture [22]. Clinical manufacturing had taken place in 20-, 40-, 100-, and 200-L bioreactors. Comparability of purified product from the different scale cell culture operations was demonstrated by an ELISA, high-performance size-exclusion chromatography, oligosaccharide profile evaluation, MALDI-TOF mass spectrometry, electrophoresis, pharmacokinetics, stability, and process residual profiles. Consistency lots were made in 500-L bioreactors, and the same tests confirmed that the product was again comparable. A further change was made when the manufacturing was transferred to another facility in which the bioreactor scale was from 400 to 10,000 L. Again, no significant differences were observed when the assays described previously were used.

For some cells, proteases are particularly problematic, causing product degradation and considerable variability. For production sources such as CHO cells that secrete glycosylated products, some firms use batch or fed-batch cultures. Others use continuous cultures, which may be more productive but are generally more difficult to control and validate. Prior to validation it is necessary to define the size of each collected pool. It is unlikely that the secreted product can remain viable for a long time because of proteolytic degradation, aggregation, and other factors that may cause denaturation. Some firms have genetically engineered cell lines to reduce protease expression. Bulk harvest pooling criteria and storage conditions must be established and validated. If five pools are collected, for example, each must have set acceptance criteria prior to combining them for further processing, otherwise there is the risk that a firm might combine acceptable and nonacceptable pools (basically, combining a good lot and a bad one to make a good one). During validation runs, pools should be analyzed separately.

Prior to further processing of the bulk harvest, it should be tested for sterility, mycoplasma, and viral contamination. In the case of CHO cells, an in

vitro virus detection assay is employed. This testing is performed on every lot. Electron microscopy is also used to determine the amount of retroviral particles, but this is typically done on only three to five lots to quantify the viral load as a starting point for validation of viral clearance [23]. These lots need to be produced at the scale and with all conditions intended for licensure of a product. Adamson has described some case studies for CHO cell culture validation and process characterization [24].

## **B. Isolation and Recovery**

If the product is secreted, recovery may involve a simple filtration step to remove any cells and cellular debris. Other clarification techniques include centrifugation and expanded bed adsorption [25]. For such intracellular products as recombinant proteins produced in *E. coli*, the product may be denatured and located in inclusion bodies within the cells [26]. Bacterial cells are typically concentrated by centrifugation or crossflow filtration, washed, and then disrupted by homogenization. Inclusion bodies are then isolated, and the protein product extracted and refolded. Validation of recovery operations for an *E. coli* product is described by Seely et al. [27].

Clarification steps must be validated to yield product with a given specification (e.g., no viable cells and a defined particulate level, if any). The specifications should enable production of feedstream for the purification steps. Varying amounts of cell fragmentation during processing can lead to out-of-specification material in the next step. A recent FDA form 483 noted that for a 3.0- $\mu\text{m}$  filter used to clarify the fermenter harvest, no study had been conducted to evaluate the effect of operating the filter at the specified maximum pressure limit on cell fragmentation.

For products located in inclusion bodies, product extraction and removal of extraction solutions must be validated. The extent to which the product can be refolded must be defined. Validation efforts are directed toward demonstrating consistency of refolding as well as removal downstream of any improperly folded product.

After the bulk harvest is isolated, stability must be validated for the hold period prior to further processing. Specifications on the bulk harvest usually include pH, conductivity, bioburden, endotoxin, and protein concentration, along with product concentration.

## **C. Downstream Purification**

Chromatography and filtration are the primary downstream purification steps. In general, three to five purification steps are performed to achieve the requisite purity for a protein product. The required degree of purity depends on product indication, dose, patient population, and the risks associated with the impurities

derived from the source material. The validation of chromatographic processes has recently come under more regulatory scrutiny, as evidenced by a review of recent 483s [28]. The parameters established in development and validated once the process is characterized include resin and filter characteristics that are relevant for the specified separation, column packing quality and consistency, product purity and impurity profiles, and consistency of sanitization and cleaning.

## 1. Chromatography Resins

Chromatographic resins contain a great deal of surface area, and a clear understanding of what is occurring on the surface in terms of carryover of risk factors is not always possible. Cleaning and sanitization, as well as column lifetime, are issues that must be addressed in development and validated at pilot or full scale.

Column resins are considered as raw materials and at a minimum must be quarantined and tested for identity prior to release. Purification processes need to be validated in such a way that the next lot of resin will not have sufficient variability to cause a batch failure. This is accomplished by understanding separation mechanisms, what each step accomplishes (e.g., how much of specified impurities is removed), and the control parameters under which the acceptance criteria are met. Control parameters may include product concentration, total protein concentration, feedstream volume, impurities (both profile and amount), flow rates, ionic strength, and pH. It is always advisable to use more than one lot of chromatography resin in development and to evaluate the range of specifications the vendor provides. For example, it might be useful to test a process at the limits of the available range of milliequivalents of charge groups for a given ion exchanger. Although this is part of process design, a process is not capable of being validated if the variables are not understood and established broadly during the development stage and tightened as more is learned later in the process.

## 2. Filters

Filters are used for clarification, removal of small molecules, exchange of buffers, and concentration of product, as well as sterilization and virus removal. A recent review of validation of filtration describes the critical validation issues [29]. Filter compatibility is tested with process conditions to avoid nonspecific binding of product to the filter or addition of extractables to the process stream. Extractables are defined and limits established based on final product safety studies. Special considerations apply for sterilizing filters and those that are designed for virus removal. These filters are single use, however, which simplifies the validation effort.

### 3. Column Packing and Storage

The amount of resin to pack in a column, column geometry, flow rates, pressure, column hardware, and wetted materials of construction should all be evaluated in development. Chromatography columns must be properly packed prior to validating the purification process. From a business perspective there should be some criteria other than purification of the product by which the quality of the packed column can be assessed prior to applying the feedstream, which by this time in the process is quite expensive. Height equivalent to a theoretical plate (HETP) and asymmetry determinations can be used to evaluate the quality of column packing, but may have limited value for some types of packed columns [30]. For example, for on-off types of chromatography, such as affinity, the packing quality may not be at all relevant. For gel filtration, however, asymmetry determinations may be essential to ensure the column packing will be sufficient to enable the necessary degree of purification to be achieved. Even when HETP and/or asymmetry are not relevant to the separation capabilities, measuring these parameters can sometimes give an indication of other problems associated with the packed column (e.g., clogging or gross contamination). Most firms include HETP measurements on a periodic basis to ensure column integrity. The acceptable ranges of HETP and/or asymmetry values can be determined from development data that show consistent product purity and impurity profiles with columns packed to a specified HETP or asymmetry value. Although it may not be necessary to set a specification for HETP and/or asymmetry, specifications must be established for both bioburden and endotoxin.

Removal of carbon-containing storage solutions from packed columns is most often tested by using total organic carbon (TOC) assays to evaluate the column effluent. Gas chromatography may also be employed during validation to ensure removal of ethanol, which is commonly used in shipping of chromatography resins. During storage, an additional cleaning effect due to extended contact time with the storage agent may be observed. Resin leakage is also a possibility. Total organic carbon is sometimes useful to assess the amount of leakage and validate removal of leakage products prior to reuse of the column [31]. Questions from regulatory agencies related to storage have included “What is the expected storage time based on validation studies for the regenerated column?” and “Provide resin stability data for the proposed base storage conditions” [32]. In a 1998 approval letter, a firm was told to “institute for every column run bioburden monitoring of the ion exchange column storage solution to ensure that storage conditions and storage buffer routinely maintain a bacteriostatic effect.” In 1999, an FDA warning letter noted that there were no data to demonstrate bacteriostatic effectiveness of the storage solution for a purification column.



#### 4. Process Validation

Validation of each chromatographic and filtration process step requires the use of orthogonal analytical methods, some of which may not be incorporated into manufacturing. For each step it is important to define acceptable ranges for all control parameters and set acceptance criteria on purity and impurities. A clear understanding of what each step is achieving is essential. Some firms use the term forward processing criteria to describe the values of various parameters that must be achieved to allow the process to continue. The forward processing criteria are defined in development and then modified as the process is further understood. (See Table 4.)

Minor changes in some operating parameters can have major effects on removal of specific impurities. The variability that might occur in virus clearance is discussed below. Changes in scale also require validation. Generally, chromatography and filtration are fairly simple to scale up, and changing scale in these purification steps is generally not as complicated as the changes that can occur when cell culture scales are changed.

Whereas shear is not a problem in chromatography, there is a greater chance for it to occur during filtration. When the scale is changed in filtration, shear can lead to degraded product. Most of the shear effects occur due to system design at sites such as valves, elbows, and ports [29].

#### 5. Resin and Filter Reuse

Packed columns are used repeatedly for most biotechnology processes. Regulatory agencies have expressed concern that column performance may deteriorate with continued use. Industry has responded by employing resin lifetime studies at both small and production scales [33]. Validation of the ability to produce consistent product for the lifetime of the resin is essential, but there are currently some in industry who believe that small-scale studies extended to the end of

**Table 4** Some Operating Variables and Forward-Processing Criteria for Purification Operations

---

Operating variables:	Forward processing criteria:
Total protein load	Product purity
Sample volume	Product yield
Conductivity	Removal of specific impurities
pH	Conductivity
Flow rates	pH
Pressure	

---

resin use may not be necessary in all cases and that concurrent validation may be sufficient. The small-scale models are validated by demonstrating that the chromatographic performance (measured by parameters such as purity, yield, and removal of specific impurities) is the same as that found at pilot or full scale. In cases in which in-process monitoring tools are available it may be feasible to consider concurrent validation.

Unlike sterilizing and virus removal filters, tangential flow filtration (TFF) filters are often reused. Flow and integrity tests are necessary to ensure the filter remains the same after usage and cleaning. Consistency of filtrate and retentate streams is validated using relevant validated assays that are specific for each process and product.

## 6. Cleaning and Sanitization of Columns and Filters

Cleaning validation of any component with a large surface area can be problematic. With chromatography and TFF, the concerns are related to carryover of product, degraded product, and impurities. These are not sterile processes, and there is a potential for microbial organisms to be retained on column resins and filters. Cleaning and sanitization issues have resulted in several FDA form 483s. One of the reasons a firm was recently told to stop manufacturing a product was that it had not validated the sanitization of a chromatography resin. A better understanding of the effectiveness of cleaning protocols and, as a result, the ability to validate cleaning, should result from the development of more sophisticated analytical tools. For example, PCR may be of considerable value in understanding removal of viruses from resins. It is often the lack of detection tools that causes concerns related to carryover.

Most of today's resins and filters can be cleaned and sanitized with agents such as sodium hydroxide, which has been shown to be very effective [34]. In some cases, however, affinity chromatography ligands, especially those that are proteinaceous, are not resistant to the rather harsh conditions necessary to inactivate viruses, fungi, and bacteria or to remove residual product and impurities

## 7. Leakage and Extractables

Leakage from chromatography resins, filters, and wetted equipment components should be investigated. Most leakage occurs during the use of harsh solutions employed for cleaning and sanitization, but leakage may also occur during storage of chromatography resins. Validation of removal of leakage products from the product may be necessary. This is particularly true when affinity chromatography is employed. The leakage product is usually a complex of ligand and product, which may be immunogenic. Although the amount may be very small, it should be validated that subsequent steps will remove any potential leachables

to an acceptable level, which is determined by performing a risk assessment based on the product dose and indication as well as patient population.

Filter extractables are usually identified and tested for biological reactivity. Weitzmann has described the use of model solvents for evaluating filter extractables [35]. Unlike filters, most commonly used chromatography resins are carbohydrate-based, and while data on the toxicity and biological activity of leachables should be available, it is generally not as great a concern. On the other hand, the same principles used for testing filter extractables may be applicable for new polymers used in chromatography.

## 8. Validation of Viral Clearance

Validation of viral clearance is a major concern for products derived from mammalian cell culture and transgenic animals, as well as for viral vectors used for gene therapies. As we learn more and more about potential risks from newly found viruses, the requirements for validation increase. The increased concerns may be reflected in the number and types of viruses that are used for viral clearance studies. Both relevant and model viruses are used. A recent review of validation of the purification process for viral clearance evaluation provides further information on selection of viruses and performance of the studies [36].

Several documents describe the requirements for viral clearance studies. The ICH guidance on viral safety evaluation provides information on the design of viral clearance studies and their interpretation [37]. Unlike most other aspects of process validation, viral clearance cannot be performed at full scale. There are several reasons for this. Direct testing methods may not detect low concentrations of virus, which requires that viruses be spiked into the feedstream. Assays may detect only known viruses, and they may also fail to detect variants. Worker safety is another issue that necessitates the need to perform the validation at a small scale. Scaling down is addressed in the ICH guidelines and in the literature [38,39].

Inactivation, filtration, and chromatography are commonly used to clear viruses. Clearance may be due to inactivation of viruses or to physical removal. Commonly used inactivation techniques include low pH, solvent/detergent treatment for enveloped viruses, and severe heat treatment. Removal is commonly achieved with specially designed filters or by chromatography. Removal by chromatography is often subject to variability in operating parameters. Inactivation and filtration are usually considered robust (i.e., not subject to slight changes in operating conditions). Clearance of viruses by filtration has been discussed by Aranha-Creado [40]. Regardless of the clearance mechanism, each feedstream must be challenged with a virus spike and the clearance analyzed at small scale after ensuring that the small scale is validated to represent manufacturing conditions.

Viral detection assays based on infectivity suffer from significant variability, which necessitates the use of statistical evaluation. Polymerase chain reaction-based assays are currently being developed and validated for viral clearance. With PCR assays, there is a potential to distinguish between inactivation and physical removal, perform mass balance studies, evaluate more than one virus at a time for a given process step, reduce the time for completing clearance studies, and accurately quantitate the amount of virus bound to such surfaces as chromatography resins. Table 5 compares the assay precision between an infectivity assay and a quantitative PCR assay.

Regardless of which assays are used, there are many variables that must be controlled during viral clearance evaluation. Some of these are listed in Table 6.

## V. WHAT TO DO WHEN

There is clearly much to do to validate a biotechnology process. Obviously not all of it can be accomplished prior to entering clinical trials. As a process is designed, documentation should be sufficient so that the rationale for the devel-

**Table 5** A Comparison of Precision Between an Infectivity and a PCR Assay

TCID50 (individual results)	QRT-PCR (individual results)
$3.55 \times 10^7$	$4.29 \times 10^9$
$1.51 \times 10^7$	$3.83 \times 10^9$
$2.69 \times 10^7$	$3.76 \times 10^9$
$2.00 \times 10^8$	$4.21 \times 10^9$
$6.31 \times 10^7$	$3.64 \times 10^9$
$8.51 \times 10^7$	$3.60 \times 10^9$
$4.79 \times 10^7$	$3.67 \times 10^9$
$6.31 \times 10^7$	$3.94 \times 10^9$
$2.00 \times 10^7$	$3.76 \times 10^9$
$4.79 \times 10^7$	$3.70 \times 10^9$
$6.31 \times 10^7$	$3.21 \times 10^9$
$3.55 \times 10^7$	$4.06 \times 10^9$
$1.12 \times 10^7$	$3.33 \times 10^9$
$2.00 \times 10^7$	$3.62 \times 10^9$
$3.55 \times 10^7$	$4.02 \times 10^9$
$8.51 \times 10^7$	
Average = $5.34 \times 10^7$	Average = $3.78 \times 10^9$
Standard deviation = $4.54 \times 10^7$	Standard deviation = $0.30 \times 10^9$
CV = 85%	CV = 7.9%

**Table 6** Some Variables in Virus Clearance Validation Studies

---

Virus selection
Virus titer
Buffer/product interference
Buffer/product cytotoxicity
Suitable spiking and sampling points
Scale-down
Effect of spiking on process step
Freeze-thaw effect on enveloped viruses

---

opment of a given process is clear. Understanding the risks and the process capabilities enables a graduated approach to be taken.

At the earliest stages of clinical trials it is likely that many changes are still being made to improve the process and resulting product. The use of suitable analytical tools to assess process changes is essential at this stage when the characterization of the product and process is not as complete as it will be by phase III. It is likely that more assays will be employed early on than at later stages when there is less variability in the process. Relevant assays are essential to link pharmacological and toxicology batches to clinical trial batches.

Prior to phase I clinical trials, process steps and assays that relate to safety should be validated. For example, sterility assays and sterilization processes must be validated. Cell lines should be qualified prior to any clinical trials, including testing for adventitious agents and identifying and quantifying indigenous virus. Virus clearance steps should be validated, and removal of any potentially toxic or otherwise harmful agents should be validated [41,42].

The product structure should be described in detail and there should be an estimate of the stability based on biological activity. The assays used to determine structure and stability will most likely be qualified, but not fully validated at this stage. Considerable thought must go into qualification of the methods upon which structure and stability are assessed at this early stage, however. One of the most important activities at this early stage is putting aside retention samples that are stored properly and can be used to evaluate the impact of process changes.

By phase II, stability assays should be validated and a good faith effort made to validate all in-process tests. Release assays should also be validated. Removal of product and process-related impurities should be demonstrated. Stability of cells during growth should be validated.

During phase III any effects of scale changes should be validated and multiple lots placed on stability test. Extensive viral clearance studies should be

performed where relevant. Host cell protein and in-process assays are typically validated at this stage. Potency assays should be validated prior to submission of a license application. Process validation at phase III usually results in a better understanding of the process and frequently enables specifications to be tightened.

## VI. CURRENT AND FUTURE ISSUES

Current and past FDA 483s provide insight into concerns expressed by regulatory authorities. When reading these documents it is important to recognize that we do not have the full picture. On the other hand, we may gain valuable information. Validation is a common cause for issuance of 483s. Some recent 483s are shown in Table 7.

Validation of biotechnology processes should provide assurance of consistent product quality. Too often firms spend inordinate amounts of time on equipment qualification and ignore some of the more important elements of process validation. Some firms do too much; others don't do enough. Although safe and efficacious biotechnology products have been on the market for some time, it is clear from recent gene therapy trials and from available knowledge of cell lines that there are potential and sometimes significant risks. Over the last decade, however, the biotechnology industry has learned that certain controls and validation efforts enhance product safety. This has led some to suggest a generic approach can be taken for some aspects of process validation for some previously used cell lines. For example, the use of generic viral clearance studies

**Table 7** Some Comments Related to Problems Associated with Validation

---

In-process and release testing assays not validated.
Stability data to support intermediate product hold period not adequate; did not include three consecutive lots held for the expiry period.
No investigation regarding variability of peak cutting. Peak cutting is conducted to accommodate capacity of vessel.
Cleaning validation of resins at end of lifetime use did not demonstrate removal of endotoxins after sanitization and cleaning.
Cause of sudden change in output volume not determined.
No demonstration of bacteriostatic effectiveness of storage solution used for chromatography column.
No data available to demonstrate assays used in stability testing of bulk are stability indicating.
Process validation did not start with predetermined in-process specifications.

---

**Table 8** Current and Potential Trends in Validation of Biotechnology Products

---

Generic validation

Concurrent validation for resin lifetime

Combined clearance studies

Increased use of comparability protocols for validated changes

Potential new risks found by increasingly sensitive assays

---

is discussed in the U.S. FDA's *Points to Consider in the Manufacture and Testing of Monoclonal Antibody Products for Human Use* [43]. Others have suggested a generic approach to validation of removal of host cell proteins and DNA from CHO cell-derived products [44]. This somewhat controversial approach has some merits, but clearly depends on knowledge of the risk factors, previous experiences, and the patient indication. In some cases, a generic approach may expedite the delivery of lifesaving drugs.

A few other issues related to process validation are under discussion. One is resin lifetime. Some firms are proposing concurrent validation rather than generating prospective laboratory scale for the entire lifetime. The concurrent approach would probably require more in-process testing, but the data generated may be more reliable since they are obtained at manufacturing scale. Clearly, eliminating the small-scale studies at this time for steps in which viral clearance is claimed will be quite difficult if not impossible.

The specificity of PCR should make validation efforts for the clearance of viruses, DNA, and host cell proteins more efficient by combining studies and increasing the speed of the assays. In the case of DNA, the assay sensitivity may enable validation to be performed at full scale and eliminate the need for more costly and less accurate small-scale spiking studies.

Today's analytical tools enable changes to be made and validated for comparability so that beneficial changes can be implemented more rapidly. Comparability protocols have already been approved for several changes, including extension of cell culture time and scale up of chromatography [45,46]. As more sophisticated validatable analytical tools enable the demonstration of comparability, more validated changes will be implemented to improve product quality and the efficiency of manufacturing (Table 8).

## VII. CONCLUSIONS

Validation requires good process development. This is especially relevant in biotechnology, in which complex biological systems are usually involved. These biological systems have inherent risks, and validation of removal of both known

and potential risk factors is essential for the continued manufacture of safe and efficacious therapeutics [47].

## REFERENCES

1. Zhang, P-F., Klutch, M., Muller, J., Marcus-Sekura, C. J. Susceptibility of the Sf9 insect cell line to infection with adventitious viruses. *Biologicals* 22:205–213 (1994).
2. Committee for Proprietary Medicinal Products. Position Statement on DNA, CPMP/BWP/382/97. Available at [www.eudra.com](http://www.eudra.com).
3. U.S. FDA. *Points to Consider in the Manufacture and Testing of Monoclonal Antibody Products for Human Use*. Rockville, MD (Feb. 1997).
4. Burman, S., Venkat, K. Role of analytical testing in biopharmaceutical analysis. In: G. Sofer, D. W. Zabriskie, eds. *Biopharmaceutical Process Validation*. New York: Marcel Dekker (2000).
5. Dongre, A. R., Eng, J. K., Yates, J. R. III, Emerging tandem-mass spectrometry techniques for the rapid identification of proteins. *Trends Biotech* 15:418–425 (1997).
6. ICH Q5C. Quality of Biotechnological Products: Stability Testing of Biotechnological/biological Products. (1995).
7. Reubsat, J. L. E., Beijnen, J. H., Bult, A., van Maanen, R. J., Marchal, J. A. D., Underberg, W. J. M. Analytical techniques used to study the degradation of proteins and peptides: chemical instability. *J Pharm Biomed Anal* 17:955–978 (1998).
8. Li, S., Schoneich, C., Borchardt, R. T. Chemical instability of proteins. *Pharm News* 2:12–16 (1995).
9. Bruno, J. Application of biosensor assays for the characterization of biopharmaceuticals. 4th Symposium on the Analysis of Well Characterized Biotechnology Pharmaceuticals. San Francisco, Jan. 9–12, 2000.
10. NIH. Stem Cells: A Primer (Dec. 1999); available from [www.nih.gov](http://www.nih.gov).
11. Eaton, L. C. Host cell contaminant protein assay development for recombinant biopharmaceuticals. *J.Chrom A* 705:105–114 (1995).
12. Lupker, J. H. Residual host cell protein from continuous cell lines. *Dev Bio Stand* 93: 61–64 (1998).
13. Winkler, M. Use of generic studies and scale down models in process validation. IBC Process Validation for Biologicals. San Diego, CA, Feb. 14–15, 2000.
14. PDABiotechnology Cleaning Validation Subcommittee. *Cleaning and Cleaning Validation: A Biotechnology Perspective*. Bethesda, MD: PDA (1996).
15. Zoon K. Oral presentation. FDA (April 1998).
16. *Fed Reg.* 94:24227–24234 (1996).
17. Kelley, B. D. Identification and establishment of operating ranges of critical process variables. In: G. Sofer, D. W. Zabriskie, eds. *Biopharmaceutical Process Validation*. New York: Marcel Dekker, pp. 29–60 (2000).
18. U.S. FDA. *Points to Consider in the Characterization of Cell Lines Used to Produce Biologicals*. Rockville, MD (1993).



19. ICH Q5D. *Derivation and Characterization of Cell Substrates Used for Production of Biotechnological/Biological Products*. (1997).
20. Dusing, S. Cell line characterization. In: G. Sofer, D. W. Zabriskie, eds. *Biopharmaceutical Process Validation*. New York: Marcel Dekker, pp. 77–100 (2000).
21. Hay, R. J., Chen, T. R., Macy, M. L., Reid, Y. A. Letter to the editor reply to “Cells, Lines, and DNA Fingerprinting.” *In Vitro Cell Dev Biol* 28A:593–594 (1992).
22. Schenerman, M. A., Hope, J. N., Kletke, C. et al. Comparability testing of a humanized monoclonal antibody (Synagis<sup>®</sup>) to support cell line stability, process validation, and scale-up for manufacturing. *Biologicals* 27:203–215 (1999).
23. ICH Q5A. *Viral Safety Evaluation of Biotechnology Products Derived from Cell Lines of Human or Animal Origin*. (1997).
24. Adamson, S. R., Leonard, M., Drapeau, D., Harrison, S. A., O’Connell, B. D., Charlebois, T. S. Process validation and characterization animal cell culture processes. In: G. Sofer, D. W. Zabriskie, eds. *Biopharmaceutical Process Validation*. New York: Marcel Dekker (2000).
25. Mattiasson, B., ed. *Bioseparation International Journal of Separation Science*. Special Issue: Expanded Bed Chromatography. 8(1/5), The Netherlands: Kluwer (1999).
26. Hannig, G., Makrides, S. C. Strategies for optimizing heterologous protein expression in *Escherichia coli*. *TIBTECH* 16:54–60 (1998).
27. Seely, R. J., Tomusiak, M., Kuhn, R. Recovery operations. In: G. Sofer, D. W. Zabriskie, eds. *Biopharmaceutical Process Validation*. New York: Marcel Dekker, pp. 129–142 (2000).
28. Zabriskie, D. W. Regulatory trends related to process validation. In: G. Sofer, D. W. Zabriskie, eds. *Biopharmaceutical Process Validation*. New York: Marcel Dekker, pp. 1–16 (2000).
29. Morris, G. M., Rozembersky, J., Schwartz, L. In: G. Sofer, D. Zabriskie, eds. *Validation of Filtration*. *Biopharmaceutical Process Validation*. New York: Marcel Dekker, pp. 213–233 (2000).
30. Barry, A. R., Chojnacki, R. Chromatography media and column qualification. *BioPharm* 7:43–47 (1994).
31. Johansson, B-L. Determination of leakage products from chromatographic media aimed for protein purification. *BioPharm* 5:34–37 (1992).
32. Hsieh, P. Oral presentation. BioPharm Conference, San Francisco, May 1997.
33. Seely, R. J., Wight, H. D., Fry, H. H., Rudge, S. R., Slaff, G. F. Validation of column resin useful life. *BioPharm* 7:41–48 (1994).
34. Adner, N., Sofer, G. Chromatography cleaning validation. *BioPharm* 7:44–48 (1994).
35. Weitzmann, C. The use of model solvents for evaluating extractables from filters used to process pharmaceutical products. *Pharm Tech* 21(4): 72–99 (1997).
36. Darling, A. J. Validation of the purification process for viral clearance evaluation. In: G. Sofer, D. Zabriskie, eds. *Biopharmaceutical Process Validation*. New York: Marcel Dekker (2000).
37. ICH Q5A. *Viral Safety Evaluation of Biotechnology Products Derived from Cell Lines of Human or Animal Origin* (1997).

38. ICH Q5A. *Viral Safety Evaluation of Biotechnology Products Derived from Cell Lines of Human or Animal Origin* (1997).
39. Sofer, G. Ensuring the accuracy of scaled-down chromatography models. *BioPharm* 10:36–39 (1997).
40. Aranha-Creado, H. Filtration virus removal in process validation. *Genet Eng News* 20:64 (2000).
41. Risso, S. Oral presentation. *BioPharm* (June 1993).
42. U.S. FDA. *Guidance for Industry IND Meetings for Human Drugs and Biologics CMC Information*. draft (Feb. 2000).
43. U.S. FDA. *Points to Consider in the Manufacture and Testing of Monoclonal Antibody Products for Human Use* (Feb. 1997).
44. Winkler, M. E., O'Leary, R., Bender, J., Frie, S., Vanderlaan, M. Use of generic studies and scale down models in process validation. ACS National Meeting, San Diego, CA, March 26–30, 2000.
45. Moore, S. K. Comparability protocols update on protocols submitted: Status report, CDER experience. IBC's 2nd International Conference on Strategic Use of Comparability Studies and Assays for Well-Characterized Biologicals, Washington, DC, June 23–25, 1999.
46. Griffiths, J. M., Prior, J., Kennedy, S., McGrath, J., Barngrover, D., Hoppe, H., Edmunds, T., Hays, M., Offenbacher, T. P. Implementation of cell culture harvest extension for a therapeutic protein. ACS National Meeting, San Diego, CA, March 26–30, 2000.
47. Gardner, A. R., Smith, T. M. Identification and establishment of operating ranges of critical process variables. In: G. Sofer, D. W. Zabriskie, eds. *Biopharmaceutical Process Validation*. New York: Marcel Dekker, pp. 61–76 (2000).

# 8

## Transdermal Process Validation

**Charlie Neal, Jr.**

*Diosynth-RTP, Research Triangle Park, North Carolina, U.S.A.*

### I. INTRODUCTION

Tablets, liquids, inhalants—*transdermals*? What exactly are these “skin patches?” Why are they so special? Are they considered the “*in medicines*” of the last decade? How are they validated?

This chapter will provide an answer to each of these important questions. It will begin by providing a definition of what transdermals are, citing the advantages of these innovative drug types, and the difficulties associated with their manufacture. It will then discuss the basic elements of transdermal validation, breaking the program into manageable “pieces.” The focus will shift to discussing the unit operations required in the manufacture of matrix transdermals. The stage for the main section of this chapter will be set with a discussion of the individual components that must be qualified in support of process validation. Covered as parts of that discussion are the equipment and process qualification steps. The process qualification steps are broken down into real-world activities that support successful process qualification: process development; process ranging studies; scale-up studies, demonstrations, and trials; and process-specific validations. Each of these activities serves to increase confidence and familiarity with the qualification activities. The chapter will then divert and briefly discuss potential problems and resolutions associated with transdermal processes.

The focus then shifts to a discussion of transdermal process validation. This particular discussion will share a method for completing this critical step. Although the method for completing validation for transdermals is important, there are two other items that must not be forgotten: validation documentation and the establishment of a solid change control program. Later sections of this chapter will discuss each area in adequate detail. As the chapter draws to a

close, a brief recommendation of how to prepare for a preapproval inspection is included.

## II. TRANSDERMALS DEFINED

Before discussing transdermals, let us first acknowledge that the current good manufacturing practices (CGMPs) are regulations established by the U.S. Food and Drug Administration (USFDA). These regulations not only serve as the operating “Bible” for drug manufacturers, but also provide operating directions in the area of manufacture, processing, packing, and holding of drugs. In reality, the GMP regulations are the conscience of reputable manufacturers as they produce drug products.

A transdermal is one such drug. What does the term transdermal mean? *Trans* means through and *dermal* means skin, therefore a transdermal drug is one absorbed through the skin. *The United States Pharmacopeia* (USP) 24 [1], offers the following definition/discussion of a transdermal delivery system:

Transdermal drug delivery systems are self-contained, discrete dosage forms that, when applied to intact skin, are designed to deliver the drug(s) through the skin to the systemic circulation. Systems typically comprise an outer covering (barrier), a drug reservoir, which may have a rate controlling membrane, a contact adhesive applied to some or all parts of the system and the system/skin interface, and a protective liner that is removed before applying the system. The activity of these systems is defined in terms of the release rate of the drug(s) from the system. The total duration of drug release from the system and the system surface area may also be stated.

Transdermal drug delivery systems work by diffusion: the drug diffuses from the drug reservoir, directly or through the rate controlling membrane and/or contact adhesive if present, and then through the skin into the general circulation. Typically, modified-release systems are designed to provide drug delivery at a constant rate, such that a true steady state blood concentration is achieved and maintained until the system is removed. At that time, blood concentration declines at a rate consistent with a patient’s pharmacokinetics.

Transdermal drug delivery systems are applied to body areas consistent with labeling for the product(s). As long as drug concentration at the system/skin interface remains constant, the amount of drug released from the dosage form does not change or influence plasma concentrations, due primarily to steady state absorption in the blood stream. The functional lifetime of the system is defined by the initial amount of drug in the reservoir and the release rate from the reservoir.

In general, a typical female-oriented hormonal transdermal system will provide approximately 20 times higher systemic availability of the hormone after administration than that obtained after oral administration [2].

The facts listed above may explain why the utilization of transdermals has been on the increase in recent years. It would be good to note that countless manufacturers are now in the transdermal marketplace, with drugs ranging from nitroglycerin to hormones. In addition to the aforementioned facts, one of the main reasons, is that transdermal medications offer several advantages over other more common dosage forms. Some noteworthy advantages are that transdermals

- Provide improved systemic bioavailability of the active ingredients
- Permit slow, timed release of the active
- Avoid the affect of a bolus drug dose
- Provide for multiple daily doses with a single application
- Provide a means to quickly terminate dosing
- Provide instantaneous identification of medication in emergency

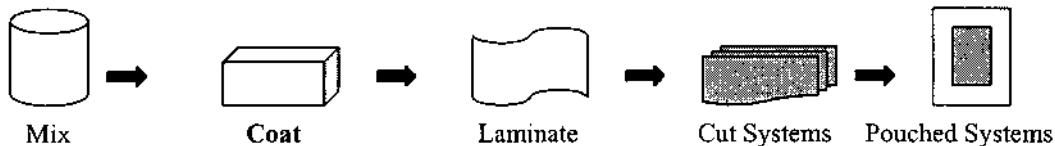
The last item may benefit from a bit of discussion. Let us take as an example a person on hormonal therapy who is admitted into a hospital with a sudden, life-threatening illness. Strange reactions sometimes occur if certain drugs are mixed within the body, thus a common concern during hospital admittance is which medications the patient is taking. If the patient cannot converse with the medical staff but is wearing a patch, it will be obvious during physical examination. If on the other hand this person is on *oral* hormonal therapy, the attending physician would not immediately know whether or not the medications prescribed will induce a negative reaction.

While the transdermal drugs offer the aforementioned advantages, their development, manufacture, and eventual validation also offer perhaps a bit more of a challenge than other dosage forms. In conjunction with the greater overall challenge, some noteworthy disadvantages are that

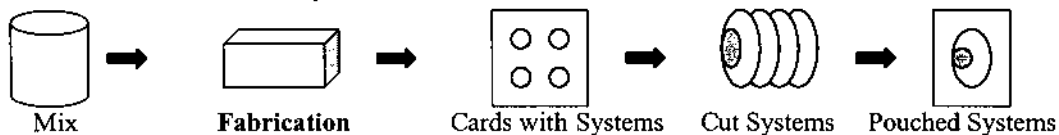
- Their process for manufacture is often complex and costly.
- They are not a suitable dosing vehicle for certain drugs.
- Their absorption profiles may vary from patient to patient due to variations in skin absorption.
- They can cause skin irritation.
- They may be conducive to bacterial growth.
- Their adhesion time is typically limited.
- The overall system quality is often very much dependent on the quality of the adhesive selected.

It should be noted that at least two distinctly different types of transdermal patches or *systems* exist. One of these is the (liquid) reservoir system. The other is the matrix system. These systems differ both in their manufacturing steps and in their final product presentation. Key manufacturing steps for both systems are illustrated in [Figure 1](#).

### Matrix Transdermal System Manufacture



### Reservoir Transdermal System Manufacture



**Figure 1** Manufacturing routes for matrix and reservoir transdermal systems.

In both systems, the active is first dispersed uniformly in a solution or gel. In the reservoir system, the homogeneous gel is dispensed onto a card that is then die-cut to yield individual systems. These systems are then pouched. In the matrix system, the mixed solution is uniformly coated onto the surface of a film. The resulting laminate is then die-cut into individual systems and pouched.

From an appearance standpoint, the reservoir system resembles a large, Band-Aid with an exaggerated “bubble” and the matrix system resembles a mere flat piece of tape. These systems are illustrated in Figure 2.

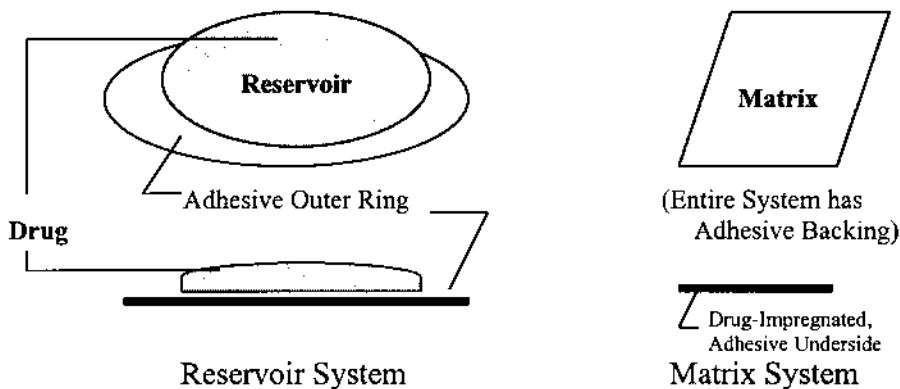
As validation is similar for both systems, the remainder of this chapter will concentrate on efforts to validate the *matrix* systems.

### III. ESSENTIAL TRANSDERMAL VALIDATION ELEMENTS

Transdermal system validation requires certain elements in order to be successful. Some of these elements are planning, documentation, time, budget, resources, quality, understanding, and communication. To illustrate how important each of these elements is, they will be discussed one by one.

#### A. Planning

Planning is necessary for solid validations. Take, for example, an environment in which key leaders know the importance of validation. All of a sudden responsible parties are directed to conduct validation on the next three manufacturing



**Figure 2** Diagram detailing differences between matrix and reservoir system.

batches, so they simply prepare a cover document for the “validation” batches. Is there any value in putting together a cover document that basically indicates that the next three manufacturing batches will be dubbed validation batches? What if one of the three has problems? Which courses of action will be taken? Validation does not just happen; it has to be planned for. This is why planning is a must in any successful validation program.

## **B. Documentation**

Good documentation should capture the entire validation activity. If there is no documentation, on what will you record your validations? Was the protocol approved? Where are the necessary procedures? What happened in validation event 2? How many samples were pulled in validation event 1? Each of these questions supports the importance of documentation.

## **C. Time**

No matter what kind of constraint is imposed, organizations must allow adequate time for validation. At the very least, time must be allotted for some degree of planning, for the requisite number of events planned to occur, and for the gathering of the results. If the validating department has been given a “drop dead” date for validation and if this date will not support the items mentioned above, there is likely no need to begin validation.

## **D. Budget**

What if a company has done a good job planning for validation, has put in place adequate documentation, has sufficient time, but does not have funding to support validation? It should be obvious that validation probably will not occur—until funding has been provided.

## **E. Resources**

Validation requires money, time, planning, and documentation. It also, however, requires *human* resources to push the buttons, collect the data, submit the samples, analyze the collected samples, summarize the reports, and gather the required signatures. Most validations are very resource-intensive undertakings. Somehow companies must assure that the requisite resources are available. Although not recommended, these resources may be external (contracted laboratory, consultants, etc.). With the exception of a qualified contract laboratory, the



reason external resources are discouraged is that validation should always use the validating company's resources for execution.

## **F. Quality**

Though CGMP validations require certain inputs from a quality department, this is not the *quality* referenced here. Good validations improve quality. Good validations result in quality. A good validation *is* quality. For example, a good validation will represent a snapshot about the process or equipment. Typically such a validation will have elements of process/product updates or historical references for the item that has been validated, therefore the package(s) that have been assembled have to possess a certain level of quality if the validation is successful.

## **G. Understanding**

Typically a validation exercise will involve representatives from multiple areas. Those involved in a validation must possess a good understanding of the purpose of validation; they cannot perform a thorough validation if this understanding is lacking. Each of these representatives must have a good understanding of why they are performing the validation and what constitutes success and failure. They must embody the *meaning* and *intent* of validation. This understanding will aide in assuring that a total team effort toward any common goal will be expended.

## **H. Communication**

The ultimate key to successful validation is communication—not just at the *development* stage or the *commercial* stage, but throughout the entire product/process development stage. Validation communications must occur on a plant-wide basis. Validation-related standard operating procedures (SOPs) should be implemented, with each impacted operating department being required to approve. This will stimulate department-to-department interest and ownership. It is therefore very important that companies promote the importance of validation through communication.

Consider an example in which validation (performance qualification) of a utility system has been mandated. The responsible resources reluctantly charge right in and begin validation. In the first week of testing, they uncover a sampling point that is not accessible. The protocol has committed validation personnel to collecting samples from this *inaccessible* point. If those responsible for validation had communications with other plant personnel, they would have

been advised that this site was not available. This is why communication is a must for any successful validation.

#### IV. UNIT OPERATIONS AND MATERIALS/COMPOSITIONS

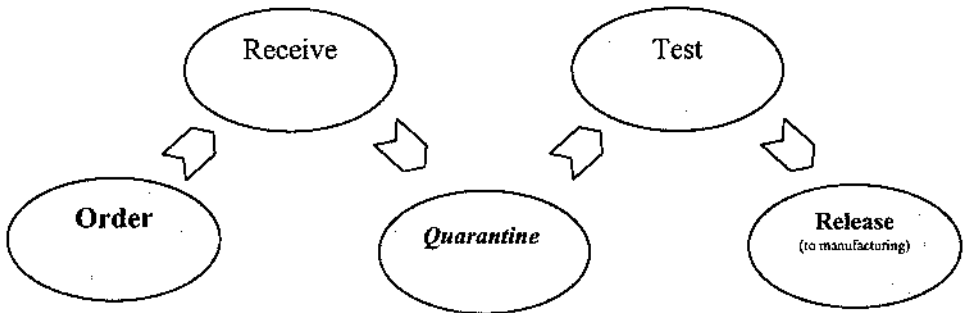
Now that we have discussed the elements of a good validation, we will pursue one of those elements: *understanding* transdermal unit operations, as this will be necessary before discussing transdermal process validations. We will start at the beginning, with the acquisition of components and raw materials.

##### A. Material Ordering and Receipt

Of course requisite materials are first ordered. Upon receipt, these items are placed in quarantine until they are tested against established specifications, meet those specifications, and are finally released by the quality control laboratory. A typical material/component flow diagram is presented in Figure 3. Once these materials are released, they are usually used on a *first-in first-out* basis.

##### B. Dispensing Process

The CGMPs require that appropriate batch documentation be prepared for any batch designated for manufacture. Following the raw material release step, specific weights of raw materials are prepared as per batch/dispensing records. Active drugs sometimes exhibit therapeutic actions that are typically harmful to animals, therefore the weighing and dispensing of these actives are usually done in an environmentally controlled chamber, which not only protects the active



**Figure 3** Path of raw materials and components.

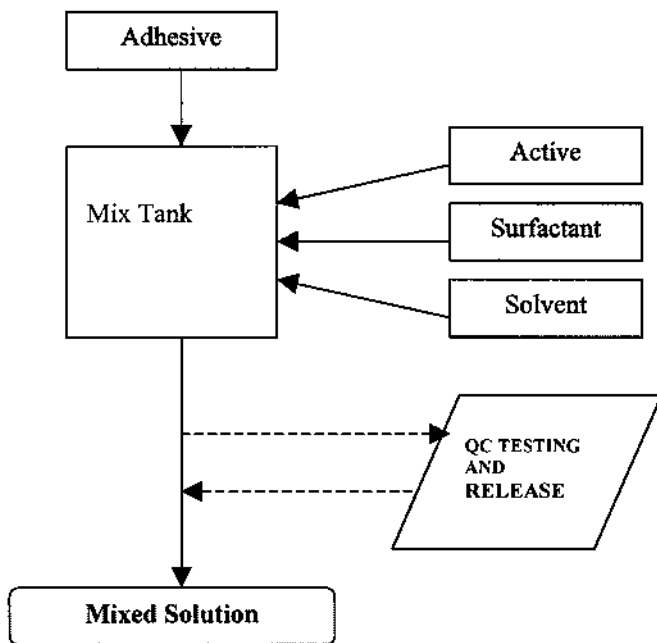
from outside contaminants, but also protects the immediate surrounding environment from the active.

### C. Mixing Process

Dispensed materials are charged to a mix tank or mixer. These components are then mixed under controlled conditions (e.g., time, agitation, temperature). Upon completion of mixing, the resulting *intermediate* is sampled and then analyzed by a quality department. While awaiting release, the intermediate is transferred to one or more uniquely identified stainless steel transfer vessel(s) and held in quarantine. Testing for release is against established specifications. This process is illustrated in Figure 4.

### D. Coating, Drying, and Laminating Process

The released intermediate is pumped from the stainless steel transfer vessels through a slot (extrusion) die situated within the coater/dryer/laminater (coater). The released intermediate, with active uniformly dispersed, is pumped through



**Figure 4** Schematic of transdermal mixing processes.

the slot die onto a release liner (typically of polyethylene) that is pulled through the oven of the coater under controlled conditions (speed, temperature, and air-flow). Likewise, this coated liner is bonded to a backing film (typically of polyester composition). The laminate resulting from this processing step is then sliced (*slit*) lengthwise and wound into independent rolls appropriate for the final system size. For example, if a *square* 25 cm<sup>2</sup> system is under development, chances are that the width of a roll would approximate 5 cm. This step is illustrated in Figure 5.

### E. Slitting/Relaminating Process

As seen in Figures 6 and 7, the final system has a tab that aides in commercial system application. This tab is formed from the release liner by the relamination step, which consists of placing a roll of laminate onto the slitter-relaminating equipment. This roll is then guided through rollers where the release liner is removed and slit (*sliced*) to the correct width. The slitted material is then placed

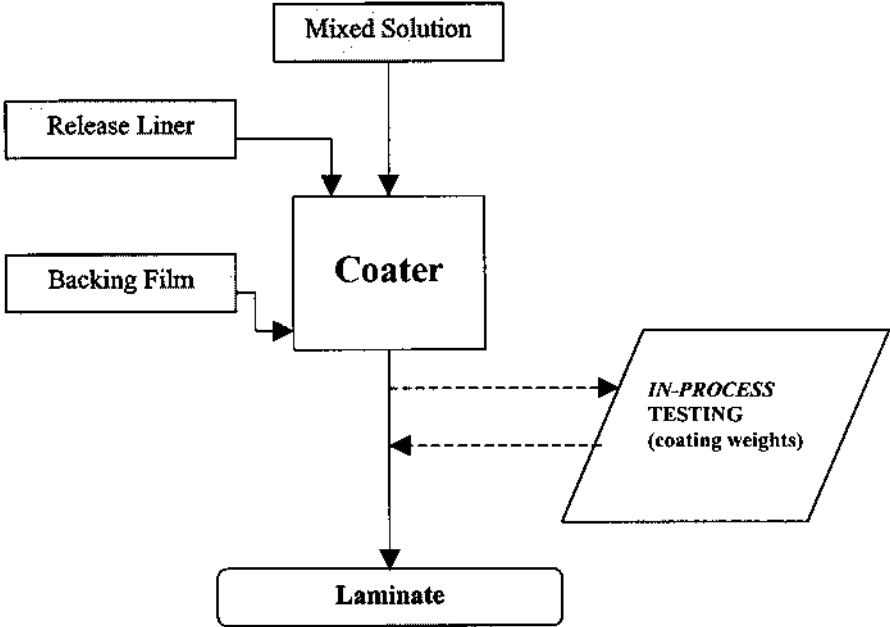
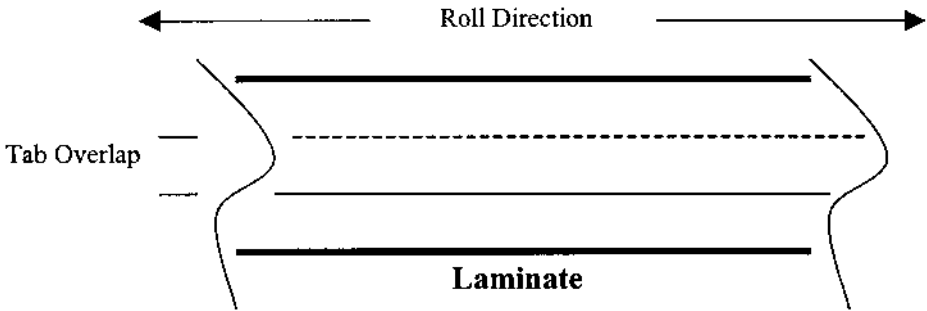


Figure 5 Schematic of transdermal coating process.



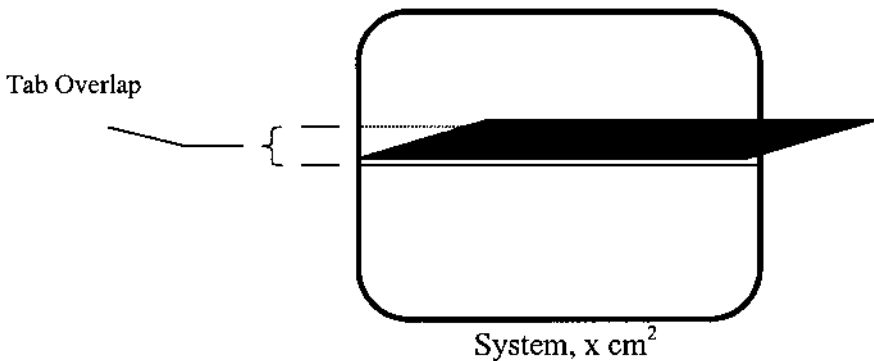
**Figure 6** Schematic of overlapped and slit section of laminate.

onto the adhesive surface of the coated backing film in an overlapping fashion. The laminate with the resulting overlapped tab is then rewound.

#### F. Pouching Process

The rewound rolls of laminate are transferred to the pouching and die-cutting equipment. The pouching process involves taking these slit and overlapped rolls, cutting them into individual systems, and then finally sandwiching them between two layers of *poly* pouch material.

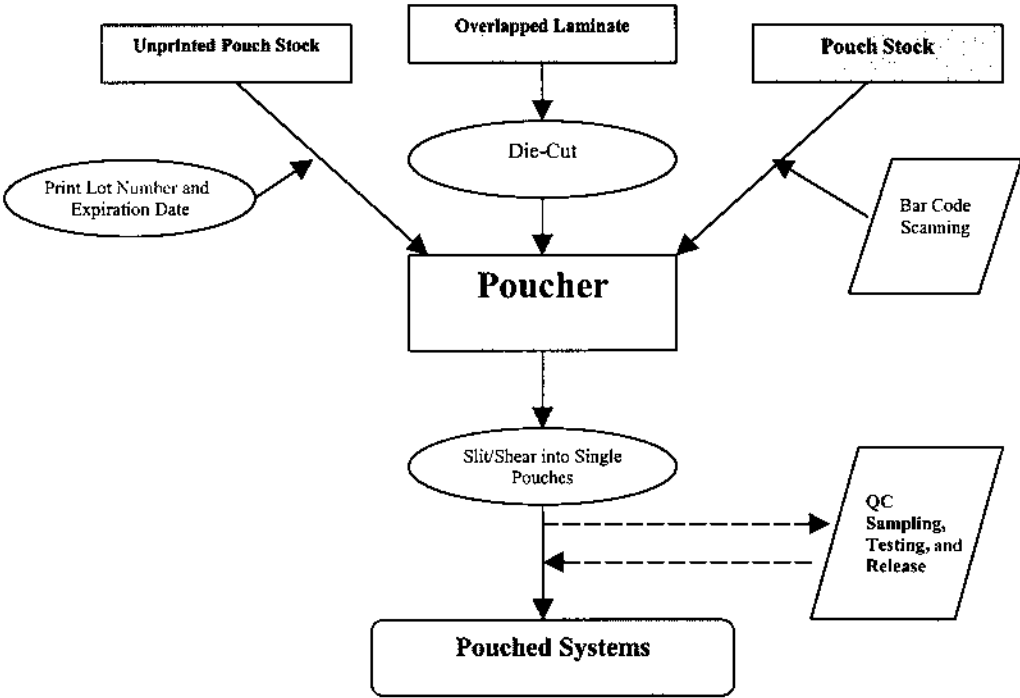
The cut systems are placed on a conveyor and moved forward to a pick-and-place station from where they are placed on a bottom pouch layer. The



**Figure 7** Typical transdermal matrix system with overlap tab.

bottom pouch layer may be printed with the lot number and expiry date prior to being cued for the cut systems. The top pouch layer is sealed to the bottom pouch layer containing the systems. Of course the sealing occurs under controlled conditions. Preprogrammed bar code scanning equipment may also be used to verify the correctness of the bar code during this process. In addition, sensors that detect the presence of the systems in the sealed pouch may also be used.

Sealed pouches are then transported to the slitting and shear stations where each individual pouch is cut. The systems are then conveyed through an accept/reject station where rejected material is discarded. The systems are sampled, tested, and released by the quality groups against preapproved product specifications. Upon quality control release, the individually pouched systems are collected for final packaging. This process is illustrated in Figure 8.



**Figure 8** Schematic of transdermal pouching process.

## G. Transdermal Packaging Process

At the transdermal packaging stage, multiple pouched and released systems are placed into the company's specified packaging, which of course results from marketing studies. The packaging operation is validated to demonstrate and establish that

1. The correct number of released units are consistently placed in the package.
2. Packages with empty pouches are rejected.
3. Only acceptable cartons are kept.
4. Only systems reflecting the correct bar code are packaged.

Finished packaging is of course subjected to the routine battery of quality control testing.

## V. WHAT DOES TRANSDERMAL PROCESS VALIDATION INVOLVE?

Assuming that each validation element is present and possesses a better understanding of the unit operations, we can now discuss some of the areas that require attention as part of transdermal process validations. Most process validations performed in a CGMP environment should involve the items listed in Table 1.

Is transdermal process validation any different from other CGMP validations? What measures are involved in this particular validation? What is the objective? Let us now explore and answer each of these questions.

A good transdermal process validation will also involve the components listed in Table 1. Transdermal process validation is therefore no different from validation for any other product or process. All of these things must undergo some form of validation to assure that the objective is met—that the end product is manufactured under a stable and consistent process and is therefore fit for

**Table 1** Components Included in CGMP  
Process Validations

---

Facility	Environment
People	Analytical laboratory
Raw materials	Equipment
Procedures	Process

---

commerce. It is typically a given that the facility has been adequately validated, therefore our focus will be directed on the other items contained in the list.

## **A. People**

Hopefully it is clear why the *people* aspect must be included in any transdermal process validation plan. One reason is that even highly sophisticated equipment cannot program itself, meaning a human element has to be involved. Wherever people are involved in a validated process, therefore, appropriate measures must be made to “validate” their roles. How is this done? Typically, people employed in CGMP environments undergo rigorous training programs that will assure that they do their tasks consistently. One notable program is the SOPs, which is nothing more than a documented method by which key activities are performed. These procedures are written and approved and must be followed to assure that the people involved repeat their actions on a consistent basis. Of course, personnel are trained and certified on each SOP that impacts their particular area(s).

## **B. Raw Materials**

Raw materials—or *starting* materials—are crucial to the end quality of any final product. Is it too much to ask the vendors to validate their raw materials? Are the drug manufacturers able to pay the cost associated with vendor-validated materials? Short of material validation, what measures are then taken to assure that the materials used possess the desired quality? How do we assure they are produced under robust manufacturing processes?

While it may be acceptable to expect vendors to validate their raw materials given today’s regulatory environment, reality suggests that the cost of the validation effort will not be borne by the vendor alone. Logic suggests that in most cases the extra cost would be added to the product and passed directly to the consumers. Logic also suggests that the extra cost shouldered by the consumers will be directly dependent upon the complexity of the vendor’s validation program.

The assessment of material quality normally starts with comparing a material’s attributes to the specifications established by the purchasing company. Once the material satisfies established specifications, efforts are made to assess the stability of the product or intermediate manufactured with the material. Typically the determination of raw material process stability is made during the product development activities. Once a vendor or vendors have been selected, three distinct vendor lots of a given raw material will be purchased. Development batches of the product are then produced using these lots, and samples from the three batches are placed on stability. The thought is that if the materials from the three lots result in product with suitable stability profiles, the raw



material(s) and the manufacturing process(es) are *valid*. Although not the perfect method of “validating” raw materials, this has been satisfactory in the past.

### **C. Procedures**

The CGMPs require that production procedures be written for any support activity that is repeated within a CGMP environment (21 CFR Subpart F-Production and Process Controls, “Written procedures; deviations”). Why is this true? Simply because validation is about proving that something performs the same task in a *consistent* manner. Validation requires consistency. Likewise, procedures that are followed *assure* consistency. It should therefore be no surprise that operational procedures are written and executed repeatedly. The ultimate test for the validity of written procedures is the acceptability of the final, validated product.

### **D. Environment**

Environmental validation entails proving and documenting that each room in which a CGMP activity occurs has the appropriate conditions. This entails monitoring and evaluating room pressure, temperature, humidity, viable organisms, and nonviable particulate counts. No in-depth discussions are planned around this particular topic, as it has been addressed numerous times in other publications.

### **E. Analytical Laboratory**

In the case of the laboratory, what is its function relative to the transdermals manufactured under CGMP? Generally the laboratory is where the various methods used to evaluate the attributes of a given transdermal or intermediate are developed, qualified, and validated. Many of these methods can often be adapted directly from the USP. If a special non-USP-derived method is required to evaluate a transdermal product, then the company is obligated to demonstrate and document that the method selected is valid. The validity of the method is determined by a thorough evaluation of the following parameters [3]:

- Precision
- Accuracy
- Specificity
- Limits of detection and quantitation
- Linearity and range
- Ruggedness
- Robustness

Often the equipment used to run the analytical methods must also undergo some type of qualification. It is suggested that installation qualification activities be performed at the very least. Many laboratory methods must undergo a “calibration” before each use, which can serve to eliminate the need for operational and performance qualifications. Again, all of the related analytical calibration/qualification/validation activities performed must be documented.

## F. Equipment

Equipment qualification typically entails *installation qualification* (IQ), to demonstrate that the equipment is indeed what was specified; *operational qualification* (OQ), to demonstrate that the equipment performs acceptably over its design range; and *performance qualification* (PQ), which demonstrates that the equipment renders consistent performance. No time will be spent providing formal definitions for these terms.

Why perform IQ? Why perform OQ? What about PQ? In upholding the intent of validation, it is *very* important that companies understand the roles of IQ and OQ. Examples will be used to convey the importance of these three qualification phases.

Assume that a very successful company produces 1000 transdermals per day. Due to market demand, its manufacturing department is instrumental in purchasing a new piece of equipment that will reportedly yield 1500 transdermal systems per day. Manufacturing requests facilities to remove the old piece of equipment and install this new piece of equipment. Upon installation, manufacturing attempts to use this new piece of equipment and finds that it won't run continuously—it only runs for 1 hr and then shuts down. In addition, manufacturing has also found that the equipment is only capable of running at 75% of its reported production rate.

After spending weeks performing an intensive investigation, technical services finds that the equipment manual for the piece of equipment (which was still with the vendor) has a disclaimer that plainly states that the equipment must undergo a 3-month break-in period during which the rate of production is 60–80% of the final production rate. Further, this manual also states that the equipment must be lubricated once an hr for the first month. If not lubricated, the equipment will shut down.

How would performing an IQ have prevented this from happening? One of the purposes of the IQ is to acquaint the purchaser with the newly purchased equipment. It is a mechanism for establishing and documenting that the equipment ordered is what was desired. It should have required that the equipment manual be received and on file within the company. A good IQ program would have also required that certain maintenance activities be performed on the equip-

ment and that the necessary preventative maintenance activities be entered in the company's PM program.

How would performing the OQ have helped avoid some of the problems encountered with the new piece of equipment? Well, for one thing, the OQ would have uncovered the true rate of production (although this should have been uncovered in the IQ by reviewing the equipment manual), which sometimes differs from the claimed rate.

Assume that the new piece of production equipment is operating without incident for a year or more. The vendor used brand name parts for the piece of equipment but went bankrupt. All of a sudden, a key part on the equipment breaks. For some strange reason, facilities cannot figure out the part number. Unfortunately, there is no documentation because there was no IQ performed, which would normally detail the spare parts and of course part numbers and drawings.

The PQ phase is as important as the IQ and OQ phases, as it serves to establish that the equipment is capable of performing its activity on a *consistent* basis. This phase may be viewed as a transition phase to the actual validation phase.

## **G. Process**

The transdermal *manufacturing* process is typically validated after the equipment qualification steps have been successfully completed. A good process validation requires each of the preceding validation steps be done successfully. Given that they are successfully completed, the full-scale process for manufacturing the transdermal is run three consecutive times. All formal SOPs (production, laboratory, warehouse, etc.) that affect the transdermal product must therefore be effective and referenced throughout process-validation activities.

## **VI. MATRIX TRANSDERMAL SYSTEM EQUIPMENT QUALIFICATION**

As with other forms of regulated drug products, transdermal manufacture requires that all major equipment be qualified. Major equipment may be defined as equipment having adjustable features or controls that makes direct contact with the product during the production process. The qualification activities performed for major pieces of equipment associated with the manufacture of matrix transdermals will be discussed in this section. Major pieces are captured in [Table 2](#).

As an example of the types of activities that constitute qualification, we will take the slot dies and detail IQ and OQ requirements.

**Table 2** Major Equipment Used in Matrix Transdermal Manufacture and the Normal *Qualifications* Required

Equipment	IQ	OQ	PQ
Glove box	x	x	N/A
Mixer	x	x	x
Transfer pumps	x	x	x
Transfer vessels	x	x	N/A
Coater/dryer/laminator	x	x	x
Slot dies	x	x	N/A
Slitter/relaminator	x	x	x
Pouches	x	x	x
Packaging equipment	x	x	x

Note: All equipment to be included in *process* validation.

### A. Slot Die IQ

Of course the first item that should be documented for this equipment is the vendor. Other key items will be the dimensions, materials of construction, and any identifying numbers contained thereon. All of this information should be documented in the IQ protocol.

### B. Slot Die OQ

Here, if any mechanical function can be performed with the subject item, its range should be evaluated if that range is important to the equipment owner. For example, if the slot die has two removable pieces, the fact that they can be disassembled and reassembled should be challenged, if it has an adjustable opening, this should be challenged, and so on. All findings or protocol results should of course be documented.

Although the IQ and OQ are typically not repetitive steps, they are very important because they provide the foundation for the subsequent validation steps. They then require good documentation and also establish a certain level of trust and confidence with the equipment. The documentation serves as a snapshot or record of the equipment as it is received from the vendor.

It is extremely important if timing and budget permit to perform a trial study on any test condition referenced in the OQ or PQ documents. This is especially true for major pieces of equipment, such as a mixer or coater. The reasoning is that if a test condition cannot be achieved during *formal* qualification, a deviation and an explanation will be required, thereby increasing the documentation requirements.

These trials also increase familiarity with the equipment, but in addition to these benefits, the work done in advance of the formal program will typically eliminate the need for some of the work on the tail end of the activities. This is illustrated in Table 3.

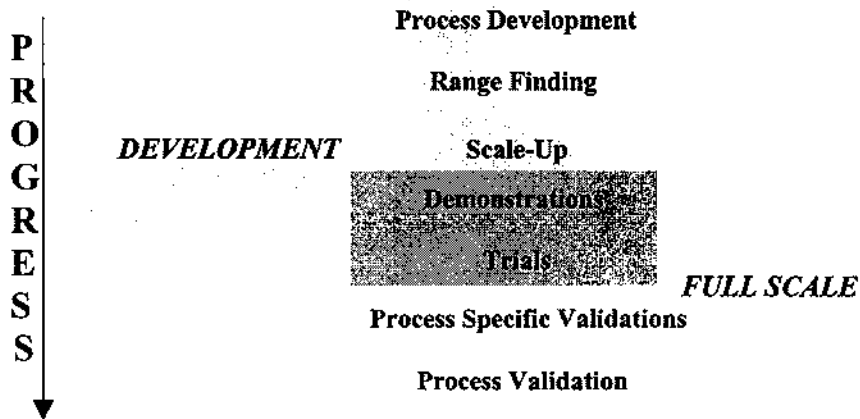
## VII. MATRIX TRANSDERMAL SYSTEM PROCESS QUALIFICATION

Assuming that the equipment qualifications have been successfully completed, the focus can now shift to the transdermal PQ, which consists of multiple pieces. These necessary processing pieces are illustrated in their proper order in Figure 9.

Of course these pieces or steps begin in development with initial process-development activities and conclude with product commercialization. All pre-process validation activities—from the initial ranging studies to the process-specific validations—can be dubbed as PQ activities, since they create a certain level of comfort with the process. These activities typically involve more than three full-scale runs—the number usually associated with validation. How exactly does this work? How can a qualification require more runs than a validation? The answer is very simple; validation *includes* qualification, which means

**Table 3** Benefits of Prequalification Activities

Phase	<i>Prevalidation</i> activities recommended	<i>Postvalidation</i> activities potentially eliminated
Installation qualification	Review purchase orders, design specifications, equipment manuals, familiarization with subject equipment	Need to write deviation reports, protocol, amendments, etc.
Operational qualification	Perform “trial” OQ to confirm ranges	Need to write deviation reports, protocol amendments, etc.
Performance qualification	Perform abbreviated PQ “trials” to confirm equipment performance	Need to abort/revise/reissue protocol or write deviation reports, protocol amendments, etc.
Cleaning validation	Perform abbreviated cleaning “trials” to confirm ability to clean acceptably	Need to revisit/revise cleaning procedure, abort/revise/reissue protocol or write deviation reports, protocol amendments, etc.
Process validation	Preceding activities	Preceding activities



**Figure 9** Order and responsibilities for *process* activities supporting transdermal process validation.

that all of these steps support the actual validation. All of these steps are required to provide the needed level of comfort mandated by the regulatory environment. Again, these activities may be more or less than those conducted by other firms.

Figure 10 lists certain notable equipment and process activities used to assure a sound transdermal process validation and the recommended sequential order of execution. Let us review the listing of these activities and then examine in some detail the process functions that should be conducted.

### **A. Maxtrix Transdermal System Process-Ranging Studies**

Assume that a basic process has been identified to produce a newly developed product on a small scale. As this process is in its infancy, operating ranges are unknown. Looking back at Figure 9, we see that process-ranging studies are conducted in development. What exactly are these studies? Before discussing what these studies entail, we must first define the critical *process* parameters. Critical process parameters are those controllable parameters that if left uncontrolled may have a negative impact on product quality. Some examples of critical process parameters are temperature, mix speed, and mix time for mixing; oven temperature, airflow rate, and web speed during the transdermal coating process; and heat seal temperature and heat seal pressure during the product pouching process. There are of course others that will be discussed later in this chapter.



***EQUIPMENT***

**1. Process/Product Development**

1.A Development Equipment Qualification

**2. Full Scale**

2.A Specify/Order Commercial Equipment

2.B Perform Factory Acceptance Testing

2.C Equipment IQ/OQ Activities

2.D Performance Qualification (PLC/Automated controls)

2.E Process Validation

***PROCESS***

**1. Process/Product Development**

1.A Ranging Studies (1)

1.B Demonstrations (1)

**2. Full Scale**

2.A Demonstrations

2.B Trials (Personnel/Process/Procedures)

2.C Performance Qualification (Process Specific Validations)

2.D Process Validation

(1) can also occur at Full scale

**Figure 10** Related activities for transdermal process and equipment validation.

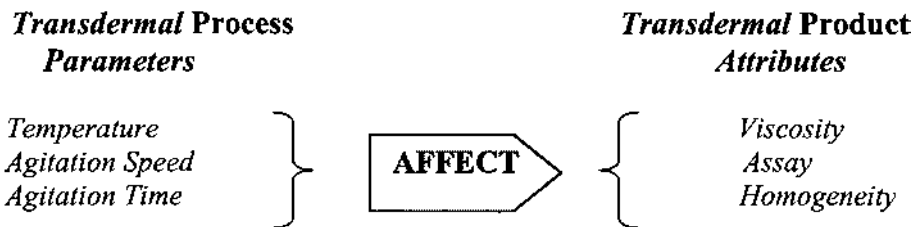
It is extremely important to understand that these parameters have an effect on the physical and chemical quality of the product. This effect is simulated in Figure 11.

Figure 11 is symbolic of the relationship between parameters and product attributes. For example, if the temperature is varied during product manufacture, the viscosity, assay, and homogeneity may be affected. The same is true for agitation speed and agitation time.

The best place for the determination of critical process parameters for any new transdermal process is during product/process development. Why is this? One reason is that this will minimize the time spent trying to validate the full-scale commercial process. In thinking about validation and assuming that the approach will be held to the widely accepted three-run rule, a common question should be how to accomplish true validation of a variable process with only *three* repetitions. Most manufacturing processes have not only a defined operating target value, but also a *range* of operation. For example, many manufacturing processes have a target mix temperature of  $t$  degrees, with a range of  $t - x$  to  $t + x$ . Realistically, it should require a minimum of nine events to gather validation data for a process with only a single variable. How can an organization “validate” the true process *range* in only three successive events? This is where process-ranging studies often fill the void left by most process validations.

Process-ranging studies involve operating the process at the extremities of its parameter ranges. For example, if you have a process that is operated at a temperature of 60–70°C, process ranging would entail data gathering at these points and the target, which should be 65°C. The same is done for each critical parameter.

As mentioned above, special studies such as range-finding studies are typically conducted during the development process. These ranging studies establish the limits for the critical parameters [4]. A statistical tool called design of experiments [5] (*DOE or factorial design*) is invaluable during such studies.



**Figure 11** Typical relationship between process parameters and product attributes.



The objective of such experiments is to identify acceptable process parameter ranges that result in the product meeting established specifications. If designed and used properly, these studies usually decrease the number of runs required to thoroughly evaluate the critical parameter limits. What must first be established is that the target identified will actually produce good product. Briefly, assuming there are three critical parameters, a DOE would involve 8 ( $2^3$ ) runs. These eight runs will involve the extremes of each of the critical parameters and will actually mix these extremes. For example, high (+) temperature will be mixed with low (–) mix speed and low (–) mix time, high (+) temperature will be mixed with high (+) mix speed and low (–) mix time, and so forth. This is illustrated in Table 4, with the + indicating the upper range limit for a particular parameter and the – indicating the lower range limit.

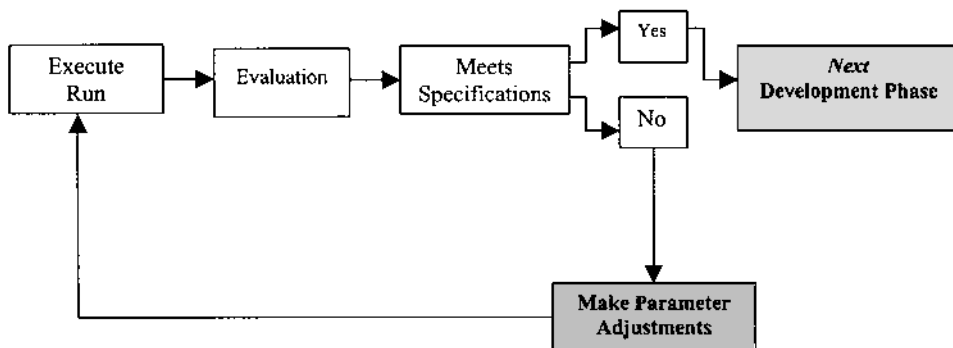
This same pattern would be repeated for each of the other unit operations—coating, pouching, and packaging. If the resulting product does not meet the specifications, then additional experiments should be done until the point is reached for each parameter that delivers acceptable product. In all cases, the operating range must be narrowed to reflect the point at which acceptable product results. Figure 12 summarizes the decisions that should be made following a given development experiment.

Although this exacting statistical mode of evaluation could conceivably involve more than eight total runs for each unit operation, it is a much more desirable starting place than the trial and error method used in the past.

Product attributes, which should also be identified early on in the product development phase, come into play during the assessment of the parameter values. What exactly are product attributes? In simple terms, these are those specifications that must be satisfied in order for the product or intermediate to be

**Table 4** Typical Design of Experiments for Transdermal Process with Three Critical Parameters

Run numbers	Mixer temperature	Mixer agitation rate	Mixer agitation speed
1	+	+	+
2	+	+	–
3	+	–	+
4	+	–	–
5	–	+	+
6	–	+	–
7	–	–	+
8	–	–	–



**Figure 12** Decisions resulting from developmental transdermal ranging experiment.

acceptable for release to the next phase. For example, if a mix solution has a final attribute of viscosity, then it should be assessed during each of the planned runs. If any one of these runs results in an out of spec viscosity, then this is a signal that some or all of the parameter limits require adjustment. In a well-designed and -executed DOE, any combination of parameter limits resulting from the study will yield acceptable product attributes. If the opposite is true, this is a clear indication that some of the limits require adjusting.

If properly documented, the results of these studies can be summarized and made available to auditing bodies. Such studies serve to complement the full-scale validation work that is done. In the absence of such studies, companies may find it necessary to explore range extremities during full-scale process validation.

Given the fact that the ranging studies have been successfully completed, attention is focused on the next process qualification step—Scale-up studies, demonstrations, and Trials.

## **B. Scale-Up Studies, Demonstrations, and Trials for Matrix Transdermal Systems**

As we know, a critical step within the development cycle of any new product or process is the scale-up step. At this particular point, it is very important that adequate communications have occurred between the group responsible for the product development and the group charged with process validation. Actually, in many organizations, the process/product development department shoulders the responsibility for product scale-up and then “transfers” the technology to manufacturing for product commercialization [6].

In some environments, scale-up is handled jointly by development and departments proficient in full-scale manufacture, such as technical services and process engineering and in some cases manufacturing. If a process has been well developed in development on subcommercial-scale development equipment, how does one assure that this same process is delivered on full-scale commercial equipment? What affect does equipment scale have on the process? Is it safe to assume that since developmental-scale equipment delivered acceptable performance it will perform likewise at commercial scale? Probably not. This is the reason most progressive companies perform what is termed *demonstrations* on full-scale equipment.

Typically, the first full-scale events are demonstrations. Some scale-up studies may be performed at full scale just before the formal demonstrations are initiated, however. This would be true in those cases in which the results of the development-ranging studies do not provide sufficient confidence or assurance. In addition to providing assurance that the process can be duplicated at full scale, demonstrations provide a platform for operator training, SOP development, laboratory method fine-tuning, equipment cleaning, and most important, site experience with the demonstrated process. It should be noted that most companies are constrained by a budget for product development, which means that they cannot afford doing a battery of demonstrations.

## 1. Why Trials?

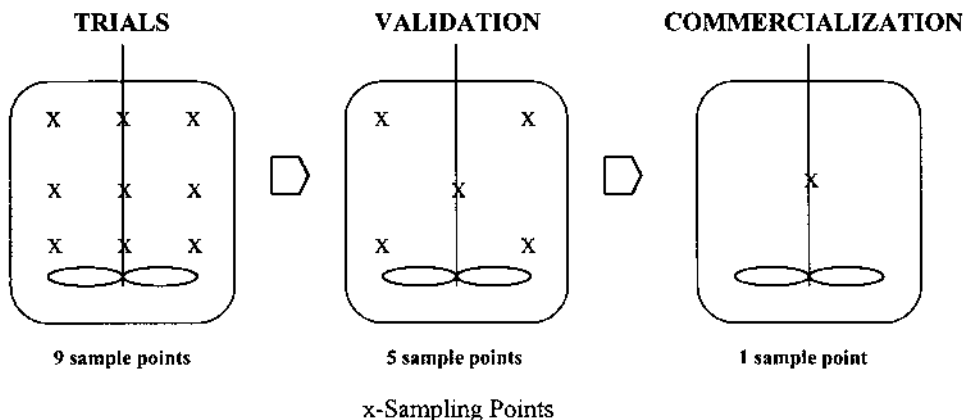
It is recommended that firms conduct trials on commercial-scale equipment during process scale-up. Think back to the very first day an airliner went commercial; in other words, the very first time an airliner loaded up customers and flew them from point A to Z. It is reasonable to think that this maiden flight was made without any trials? Absolutely not. Without being intimately familiar with the airline industry's practices, it would probably be safe to assume that the very first commercial flight with passengers was preceded by a minimum of three trials—trials to assure that the plane would ascend and descend at the pilot's commands, trials to assure that the craft would stay in flight with a full load, trials to assure that cabin pressure would be maintained, and so on. It would also be safe to assume that each of these challenges was designed to represent worst-case or stress testing. For example, if an airliner was designed to carry a 2-ton load of comfortably, it is very likely it was tested with 2000 lb plus some *safety* factor. These same principles apply to validation.

## 2. The Benefit of Trials

Let us now examine the role of trials in a CGMP environment. Cleaning validation will be the model used to illustrate the need for trials. In accordance with subpart D of 21 CFR, Section 211.67, equipment used in manufacturing trans-

dermals must undergo routine cleaning. Cleaning validations are done to demonstrate and document that residues of drug(s) and/or excipients or cleaning agents remaining on the equipment used to manufacture transdermals have been reduced to acceptable levels. During process scale-up activities and before cleaning validation, equipment cleaning *trials* are recommended [7]. Why? Simply because these trials provide an unofficial arena to firm up full-scale equipment cleaning, to test the cleaning limits, and to provide preliminary training to the operators, the samplers, and the analytical laboratory. Cleaning trials are a means of providing assurance that the cleaning procedure is ready for validation. They also serve to identify areas in which the heaviest residues are found. This is done by “stress” sampling, or sampling in every potential point that may represent the worst case. During stress sampling *or* cleaning trials, the sample points identified will typically exceed the validation sample points, which will of course typically exceed routine commercial sample points. This is illustrated in Figure 13.

Trials beg the validator to become creative. During the cleaning trials for the casting solution, one batch of scale-up solution is used to simulate three successive mix tank cleaning trials. The solution is charged in, agitated at maximum mix speed (to induce splashing) for a specified amount of time, and discharged from the tank. The tank is then allowed to sit for a specified amount of time (equal to the anticipated maximum window between tank use and cleaning). Once the time limit is reached, tank cleaning is initiated. The previously



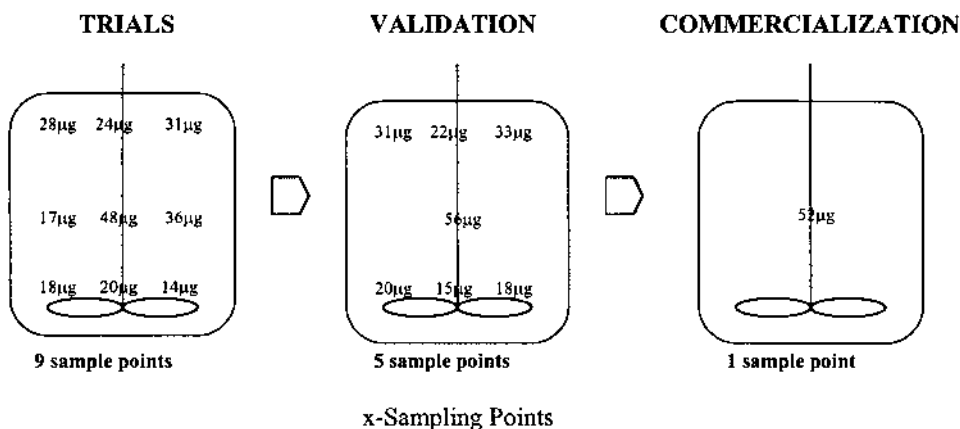
**Figure 13** Simulation of sample point reduction from transdermal trial to validation to commercialization.

used batch of casting solution is then charged back into the tank and the cycle is repeated.

It is important that the stability of the active be assured over the preliminary trials, therefore efforts are made to ascertain that the potency of the casting solution is unchanged throughout the planned trials. This is true because if the casting solution loses its potency over the course of the trials the analytical results may be skewed.

Trials typically use worst-case or stress sampling to determine the highest residue. It is suggested that once residue loading has been identified over the course of at least two cleaning trials, *validation* sampling be such that the highest residual load be sampled (Fig. 14). Once the validations have been completed, it is typically acceptable to further reduce the number of sampling locations as shown in Figure 14. In Figure 14, cleaning trials started out with nine sample points. In validation, these sites were narrowed down to five. Finally, in commercial mode the sample sites have been reduced to one. Again, these are only examples. Oftentimes the laboratory supporting cleaning validation can only analyze a limited number of samples, meaning that true stress sampling may not be done. In any event, sound logic should be used to pinpoint sampling locations.

Another good reason for cleaning trials is that during cleaning validation, every event should be performed in the absence of problems. Any failures encountered with the validation will have to be investigated and explained away, meaning that time must be expended by people to identify, review, and docu-



**Figure 14** Simulation of sample results from transdermal trials to validation to commercialization.

ment the reason(s) why the failure occurred. These trials provide a way to flush out and eliminate any potential problems with the cleaning procedure before it is subjected to validation. Finally, perhaps the main reason for performing these trials, is that the risk of losing multiple full-scale batches as a result of batch contamination is very much reduced.

### 3. Recommended Documentation for Trials

The same reasoning applies to other processes pending validation. During any trial, a “draft” protocol very close to the final validation protocol to be used should be assembled. This draft document—or any trial or draft document—is not intended for FDA review. It is simply a means for data gathering and employee training. Any trial document should be created independently and kept separate from documents supporting other activities, meaning that separate activity-driven documentation needs to be prepared and maintained. Separation is recommended because if FDA, for example, wants to dig deeper into the “process demonstration” documents, data supporting cleaning validations (specifically cleaning *trials*) will not be revealed unless asked for.

### C. Process-Specific Validation for Transdermals

Developmental activities that include ranging studies, scale-up studies, demonstrations, and trials certainly aid in establishing ranges of operation for critical transdermal process-control parameters. Is it safe to assume that just because measures have been taken to gather this information on the critical processing parameters formal process validation will be a success? One of the very first steps toward process validation is to plan for the activities. First of all, there must be a supporting structure in place for any validations performed; a validation cannot exist in a void or vacuum. Are adequate validation procedures in place? Has the existence of a solid internal document maintenance program been assured? What about validation change control? Is it set up to track all changes to equipment that has been installed? What about training in general—are there formal procedures? Equipment maintenance? Instrument calibration?

Is the equipment to be used newly acquired? If so, has it undergone requisite IQ, OQ, and PQ activities? If so, how good are the completed packages? Before the equipment was received from the vendors, were vendor equipment qualifications (also known as factory acceptance tests—FAT) conducted and were the results satisfactory? Are there any outstanding issues requiring resolution? Some assumptions will of course be made. These assumptions are listed in [Table 5](#).

All activities identified in [Table 5](#) should occur prior to beginning process validation. The economic environment of most drug companies is such that no

**Table 5** Prevalidation Assumptions for Transdermals

---

Sound development package in place
Ranging studies completed and documented
Facility qualification completed and documented
Equipment qualification completed and accepted
Appropriate analytical methodology implemented and validated
Personnel training completed and documented
Process trials and demonstrations executed and documented
Change control in place and effective
All supporting documentation (validation SOPs, demonstration documents, etc.) in place
Appropriate operating procedures (manufacturing, maintenance/preventative maintenance, cleaning, etc.) in place
Document maintenance (number, filing, retrieval) in place

---

more than three full-scale events are conducted. A *progressive* process validation program that will involve each major unit operation and end *with* the formal process validations is recommended for firms that can afford such endeavors, however. Such studies build *progressive* confidence in the processes. These studies typically prove to be an invaluable insurance policy for firms as they undergo regulatory audits.

Individual process validations or process-specific validations—*mixing, coating, pouching*—performed prior to formal transdermal process validations are a way to build this confidence and are strongly recommended. True to the term, these validations should be done on three successive events in each major unit operation. Formal validation etiquette is used (preapproved protocols, trainings confirmed, operating procedures in place, etc.). As an example, during the mixing operation the mix time and mix RPMs should be monitored periodically (kept under control) to assure consistency of the operation. Sufficient samples of the casting solution should be collected upon completion of each batch and used to establish uniformity. It is recommended that sampling be done in duplicate. The secondary or duplicate samples serve as backup samples and are invaluable in case something happens to the primary sets.

Parameters tracked during the mixing validations are detailed in [Table 6](#). Of course the equipment must operate within the acceptable ranges during the validation event.

The product or intermediate resulting from the mixing step must satisfy established specifications that represent the step's product attributes. Some mock attributes are shown in [Table 7](#).

The coated product (the cast-film laminate) is treated as an intermediate. In reality, significant efforts should be expended during the product's develop-

**Table 6** Mixing Parameter Targets and Ranges for Transdermals

Parameter	Target	Acceptable range
Mix time (min)	x	x +/- y
Mix speed (RPM)	x	x +/- y

ment to show correlation between the coating weights and final product attributes. It is recommended that during developmental work for the coating process each lane be identified and each laminated roll be labeled. As these rolls are formed during a given shift, labels should be placed strategically on the roll to indicate the time of day the laminate is coated. A sampling pattern to gather uniformity information is recommended involving *beginning, middle, and end of shift* sampling, and *left side, center, and right side of coating oven*. Any samples collected should be analyzed against pouched product specifications. The results of this study can then be used to justify eliminating formal coating product specifications at this coating stage in favor of a straightforward, periodic in-process coating-weight test.

During the coating process, controlled conditions and coating weight should be monitored periodically by the operators to assure that the environment is appropriate to reduce the content of residual solvents and to attain proper curing. The thickness of the casting solution layer should be controlled and used to assess the final quality of the systems manufactured.

Of course, equipment parameters should be tracked during the process. Mock parameters that can be tracked during the transdermal coating process are listed in [Table 8](#).

During the pouching process, operators should perform routine monitoring of heat seal temperature, heat seal dwell time, and heat seal pressure, and at the same time check the integrity of the sealant layers. It is recommended that

**Table 7** Mixing *Mock* Specifications for Transdermals

Attributes	Specifications
Appearance	Brown viscous solution
Identity	Matches retention time of reference standard
Assay	x mg/g (x +/- y mg/g)
Percentage nonvolatiles	≤x%



**Table 8** Coating Parameter Targets and Ranges for Transdermals

Parameter	Target	Acceptable ranges
Web speed (FPM)	x	x +/- y
Oven temperature (°C)	x	x +/- y

pouched systems be analyzed from the beginning, middle, and end of the batch to demonstrate process consistency. Recommended pouching process parameters to be monitored are listed in Table 9, with mock specifications listed in Table 10.

Additionally, in-process pouch integrity testing should be performed periodically during each pouching event to assure that the pouching process is consistent.

Maintaining any of these individual unit operations within the stated process parameter ranges of course, demonstrates adequate process control. As with any validation, any deviation outside the acceptable range requires investigation and documentation.

#### **D. Potential Problems and Recommended Resolutions with the Matrix Transdermal**

Problems exist for established processes, so is there any surprise that they are encountered during the early stages of process development? Surely not. It should be noted that all problems identified must be eliminated or resolved prior to transdermal validation. Validation is not just an exercise done to satisfy FDA or others in the auditing environment; it should be done with the goal of proving that a process is under control. If there is sufficient evidence that a process is

**Table 9** Pouching Parameter Targets and Ranges for Transdermals

Parameter	Target	Acceptable ranges
Heat seal dwell time (sec)	x	x +/- y
Heat seal pressure (psi)	x	x +/- y
Heat seal temperature (°F)	x	x +/- y

**Table 10** Pouching *Mock* Specifications for Transdermals

Attributes	Specifications
Drug release	$\geq x\%$ @ y time
Drug assay	x mg/g (x +/- y mg/g)
Release liner peel force	x g
Residual solvents	Solvent X, $\leq x$ ppm: Solvent Y, $\leq y$ ppm
Area dimensions (system)	x mm L: y mm W
Percentage nonvolatiles	$\leq x\%$

not yet under control, there is no reason to strain or drain a company's operating budget. It is recommended therefore that all issues be addressed during product scale-up. Actually, development is where the product/process *cause-and-effect* relationships are learned, which means that not only are *problems* realized, but also potential solutions.

Some examples of typical problems encountered with the matrix transdermal systems and the corresponding potential solutions used for these problems are identified in the following table.

#### Potential Matrix Defects

Stage	Problem	Potential solution(s)
Mixing	Poor solution uniformity/solution not homogeneous.	Increase agitation time Increase agitation rate
Coating	Poor laminate (product) uniformity.	Adjust coating rate Adjust mixing (parameters)
	Product weights too high/low.	Adjust slot die gap Adjust coating (oven) temperature
	Residual solvents too high.	Increase coating (oven) temperature Increase airflow Decrease coating weight Decrease coating rate (web speed)
	Drug content too low/high.	Adjust coating weight
	Improper coating weight.	Adjust metering pump Adjust slot die gap
	Cross-web coating is inconsistent.	Adjust slot die angle Adjust slot die gap
	Casting solution flow to the slot die inconsistent.	Increase nitrogen head pressure

## Potential Matrix Defects (*Continued*)

Stage	Problem	Potential solution(s)
Pouching	Laminate not dried uniformly.	Adjust configuration of supply air flow nozzles
	Poor pouch seal.	Adjust heat sealing temperature Adjust heat sealing pressure Adjust heat sealing dwell time
	Systems in seal.	Adjust pick and place mechanism
	Systems not picked up.	Increase vacuum to pick and place mechanism
	Systems not placed in proper pouch position.	Adjust vacuum mechanism

## VIII. TRANSDERMAL PROCESS VALIDATION

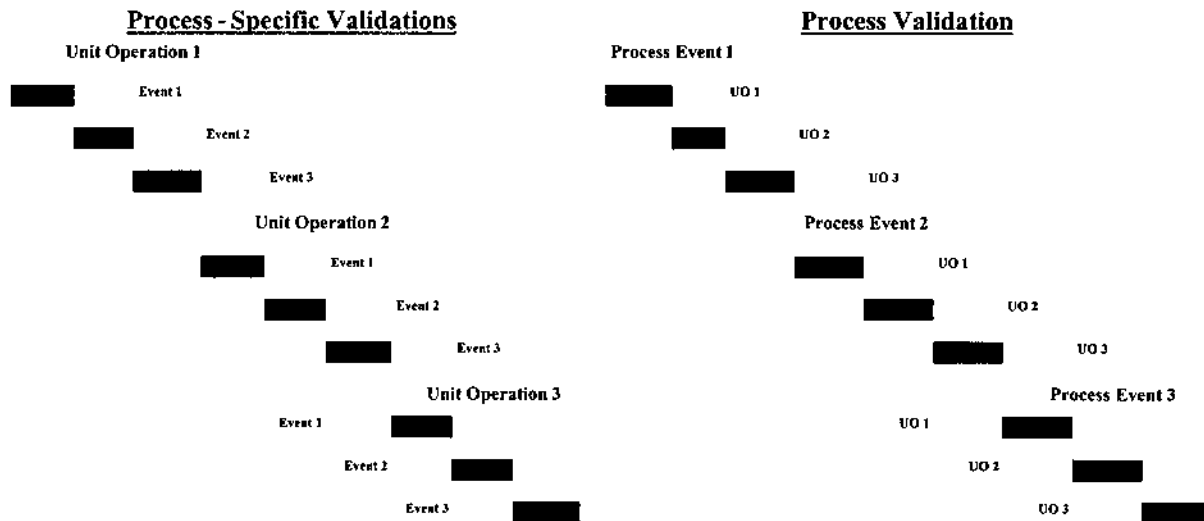
As established earlier, transdermal process validation is proving the way a transdermal product or end result is made is legitimate. This proof should be established before a product is marketed or put into commerce. What does this term require? Actually, this section, though very important, will be very short.

Discussions thus far have established that product commercialization should be preceded by a host of developmental runs (to include ranging studies), a minimum of two process demonstrations on which cleaning trials are conducted (cleaning trials are performed on both equipment *and* manufacturing rooms utilized), three individual unit operation (*specific*) validations within which formal cleaning validation is completed, and, three successive process validation events, in which *all* factors affecting the process (applicable manufacturing operating procedures, personnel, equipment, etc.) are challenged and documented.

How are these successive process validations conducted? This activity is basically achieved by combining each unit operation in a singular protocol and therein addressing every procedure and activity used to manufacture the end product. This is illustrated in [Figure 15](#).

To summarize, the number of runs actually supporting the validation of a transdermal process with three unit operations—mixing, coating, and pouching—should exceed 24, as can be seen in [Table 11](#). If the developmental ranging studies are performed on a process that has three parameters, this number quickly jumps to a minimum of 42, assuming that all of the ranging runs were a success. This of course *does not* include cleaning validation.

Why perform all of these batches during the scale-up and validation of a transdermal process or of any process? One of the main reasons is the resulting



**Figure 15** Depiction of how process validation builds. UO = unit operation.

**Table 11** Sampling of Runs Required to Support Transdermal Process Validation

Event	Full, commercial scale <sup>a</sup>				Total runs (minimum)
	Development Ranging studies	Demonstrations and/or trials	Process specific unit operation validations	Process validation	
Mixing	2 <sup>n</sup>	2, minimum	3, minimum		
Coating	2 <sup>n</sup>	2, minimum	3, minimum	3, minimum	24
Pouching	2 <sup>n</sup>	2, minimum	3, minimum		
Total runs	6 (where n = 1)	6, minimum	9, minimum	3, minimum	

Note: n-number of process parameters.

<sup>a</sup>In certain cases, “development” ranging studies were completed on commercial scale.

progressive confidence in the process. Of course, one of the downfalls with this approach is the drain on the validation budget. What must be understood is that the route chosen by a company must be adequately justified and *budgeted*.

## IX. VALIDATION DOCUMENTATION FOR THE MATRIX TRANSDERMAL SYSTEM

### A. The Protocol

Now that all of the activities that support process validation are in place or have been performed, will the work and effort be appreciated by auditing bodies? What measures can be taken to assure that they are? There is one other aspect of transdermal validation that will increase the potential for the effort to be appreciated. This element is the *protocol*. What exactly is a protocol? Who should approve this document?

Planning is key in any significant undertaking—whether it is a family vacation or a critical project within a *Fortune* 500 company. Transdermal validation likewise requires extensive planning, but in the form of a protocol. For the sake of clarity, the protocol is a bit more than a planning tool for validation; it is actually the vehicle for achieving validation. It tells the audience “By the way, planning has occurred for this transdermal activity, and we will validate as follows—.” A validation protocol generally accomplishes the following:

1. It details the item or items (“subject”) undergoing validation.
2. It provides an objective and an overview of what is being done and why.
3. It will typically reveal how many successful batches must be performed.

4. It discusses equipment used to process the “subject.”
5. It details critical process parameters, acceptance criteria, sample points, and the test methods to be used.

Let us examine what a protocol should accomplish. During an inspection of a given product or process, FDA will more times than not conduct a review of the process validation protocol. As mentioned earlier, the process entails everything used to manufacture the transdermal—procedures, personnel, methods, documents, and so on. Given the fact that the protocol will likely fall under FDA scrutiny at some point and that other documents used to complete the validation may as well, it should be easy to understand that the process validation protocol should be used to reference as many of these other supporting documents as possible.

For example, most companies would rather reference their supporting documents than have FDA ask whether or not a particular document exists. Further, this practice will assure that the company has actually taken sufficient time and prepared the document referenced. There are those companies that prefer to voluntarily attach the documents rather than just reference them. This may not be in the best interest of CGMP manufacturers for two clear reasons. First, attaching every development report, every batch record, every analytical method, every support protocol/report and so forth will make a process validation document—a hefty document to begin with—too big to read. Second, volunteering any information is considered very dangerous, as it is very rare for a company to have no dirty laundry. Why hang it out for FDA or any audience to see?

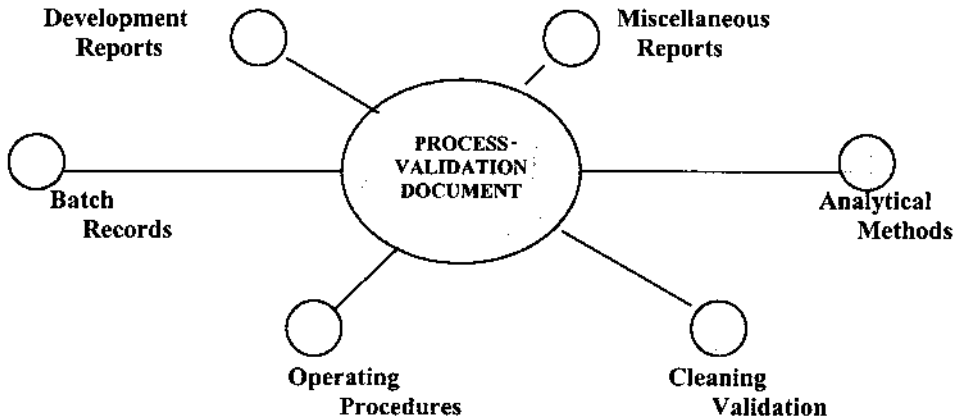
Therefore, the recommendation is that the process validation document be used as a guide document, referencing support documents as appropriate, as illustrated in [Figure 16](#).

It should therefore be clear that the protocol is a key communication tool not only for the owner, but also for *internal* and *external* auditing parties. As a communication tool, the protocol should be capable of completely informing the reader of every critical thing that happened—from beginning to end—within the activity.

What, then, are the specifics that should be reflected in a protocol designed for transdermal process validation? Perhaps a better question is what is the basic format of a protocol to be used in transdermal process validation. Let us start with the second question and establish the vehicle to be used for validating a transdermal process.

## 1. Format: Basics

As mentioned above, the protocol should reflect the item on which validation will be performed. It should have an identifying code for easy retrieval. Pages of the protocol should reflect the protocol title and the identifying code in the



**Figure 16** Schematic detailing how process validation document references other support documents.

header or the footer; likewise it is recommended that the page number be in the format of “Page *x* of *y*” and not “Page *x*,” as the former will give information as to the total number of pages included. Some of the major parts are detailed below.

## 2. Cover Sheet

A sample cover page is shown in [Figure 17](#). This page is very important, as it will identify what will be validated and provide the objective of the validation activity. The objective is actually lifted from the body of the protocol. The cover page briefly describes the major equipment required to perform the process and the rooms in which the equipment is located. It will also list the identifying document code and the persons (departments) who will be expected to approve the document. In all cases, a quality representative must approve a protocol constructed for validation. It is also recommended that a representative of the department owning the validation subject be an approver, as should any lab or support departments obligated to perform a task within the validation. Finally, experience has shown that it is wise to have an executed protocol review box resident on the cover page. (See [Fig. 17](#).) The intent is that once the protocol has been executed, someone who was not involved with execution must review the document to ensure that all the *I*'s have been dotted and the *T*'s have been crossed. This “reviewer” must be technically sound and familiar with the CGMPs. In actuality, this review is simply to assure that everything that has been committed to in the protocol has indeed been done, all of the comments are logical, all of the conclusions are sound, there are no blank spaces, and so forth.

## PROCESS-VALIDATION PROTOCOL

**DOCUMENT XYZ**

Process Validation for Manufacturing of \_ Transdermal Systems  
Date (mm/dd/yy)

**OBJECTIVE:** To validate the manufacturing process for \_\_ transdermal delivery systems by verifying and documenting that the Mixing, Coating, Slitting, and Pouching processes consistently yield product that meet commercial specifications. Three consecutive commercial-scale batches (theoretical yield: \_\_ systems) will be manufactured. For each batch, final product quality will be determined by comparing the analytical results to the established commercial product specifications. Approval of the validation document summarizing this activity will indicate that Technology Transfer was both successful and complete for this process.

**EQUIPMENT IDENTIFICATION:** Mixer manufactured by (*vendor*), with an approximate volume of 20 Gallons; Coater/Dryer/Laminator manufactured by (*vendor*); Slitter/Rewinder manufactured by (*vendor*); and, Pouching Machine (with Die Cutter) manufactured by (*vendor*). Equipment numbers are identified in the appropriate section of this document.

**ROOM IDENTIFICATION:** \_\_\_ Mixing (Room #\_\_\_), Coating (Room # \_\_\_), Slitting (Room #\_\_\_), and Pouching rooms (Room #\_\_\_), all located in the manufacturing core at \_\_\_.

<b>PREPARED BY</b>	<b>DEPARTMENT</b>	<b>DATE</b>
	( <b>Preparer</b> )	
<b>APPROVED BY</b>	<b>DEPARTMENT</b>	<b>DATE</b>
	( <b>Owner</b> )	
	( <b>Support Lab</b> )	
	( <b>Quality Group</b> )	

*Postexecution Review:*

<b>REVIEWED BY</b>	<b>DEPARTMENT</b>	<b>DATE</b>

**Figure 17** Recommended protocol cover page.



### 3. Table of Contents

The table of contents is nothing more than a map of the document listing every major section of the protocol and detailing page numbers.

It is recommended that the protocol be divided into three major sections: Section I, which discusses the background and validation methodology; Section II, which contains areas in which data collected during validation can be documented; and Section III, a section for the various attachments that will be involved. It should be understood that the contents of these sections may reside in validation-specific SOPs. Even if appropriate SOPs have been created, however, there is no assurance that the statements will be reflected in the execution of the validation. Contents of each of these three sections are discussed in the following sections of this chapter.

*Section I: Background/Methodology.* This section is the communication part of the document. It is strictly instructional, providing history, how the validation will be accomplished, and so on. There is no requirement for data entries in this first section.

*Objective.* The objective states what the intent of the activity is. The objective should be straightforward, yet touch on the underlying goal of the activity. If the plan is to prove that a piece of equipment can be powered on, *this* is the objective. If the intent is to demonstrate and document that something is and does what it purports to be and do—to *validate*—then that is the objective. One other suggestion is that the method of *achieving* the objective be touched upon briefly. For example, if three events will be executed to prove the objective, this fact should also be mentioned.

*Scope.* The scope section establishes the boundaries or limits of the validation event. It identifies every major thing to be included by identification and therefore excludes everything that is not a part of the event. An example would be, “Validation will be done on the XYZ coater using matrix components xyz.” This statement therefore excludes all coaters outside the XYZ unit and all matrix components outside xyz.

*Responsibilities.* This section captures the responsibilities of the approving departments prior to document approval. This way there will be no confusion when a responsibility arises during or after the document execution.

*Background.* The background provides the reader with a bit of history regarding not only what is being validated, but also why and how it is being validated. Typically very little detail is provided in this section.

*Process Descriptions.* The process descriptions break down and define every major process step. It should also discuss the processing sequence. For

example, “the process entails dispensing, milling, blending, and tableting. The mixing step involves taking the ingredients and agitating until—.”

**Critical Process Control Parameters.** The critical process control parameters are those controllable parameters that have impact on the final product quality. Parameter operating limits and the methods of assuring control of these parameters within these limits are discussed in this section.

**Validation Procedure.** This section is devoted to telling the audience how this particular validation will be achieved. This is actually where the validating party conveys to the audience its interpretation of FDA’s expectations of process validation. How many successful runs will be required? Three? Seven? What if a failure is encountered? Hopefully, it is obvious how important this particular section is.

**Validation Methodology.** The methodology section speaks to the areas of documentation, protocol execution, and postexecution.

**Documentation.** Documentation addresses how the entries should be made, the timeliness of those entries, and how to correct an incorrect entry. Samples of items that should be addressed in this subsection are

This protocol provides spaces to record entries. All entries required should be made and dated at the time they are performed. Questions that do not apply should be marked “NA,” initialed and dated; all blank spaces should be marked “NA”; large areas consisting of multiple blank lines should be lined through and marked “NA.” Results generated in or related to this activity should be properly documented and/or attached to this protocol. Where testing is performed by a third party, the test report should be attached to the applicable section of this protocol or included in the Validation Report.

Even though most of this is obvious or is covered by an internal operating procedure, it doesn’t hurt to communicate the expectations to the readers of the document.

**Execution.** The execution section addresses courses of action during actual execution. It mentions obvious facts about the items(s) to undergo validation. An example would be: “The process for x transdermal systems has been designed to consistently deliver satisfactory product. Challenges will therefore be made to confirm that the equipment functions properly and yields product meeting established commercial specifications.”

**Postexecution.** The postexecution subsection deals with the document flow upon completion of the activity. An example is

Upon completion of the execution of this protocol, this document and all related third party testing reports and engineering documentation are to be

submitted to the validation project manager. A validation report summarizing the results and including an explanation of all deviations from the procedures, specifications, or acceptance criteria will be prepared. This report, which will include a copy of the executed protocol, will be submitted to the approvers of the protocol. Upon report approval, the original executed protocol will be attached and submitted for internal maintenance.

**Validation Sampling Plan.** Any process undergoing validation must be sampled. This section will tell the reader the logic that went into the sample plan, the frequency of collecting the samples, the sampling locations, and so on.

**Acceptance Criteria/Rationale.** The acceptance criteria for each measurable attribute (which can be lifted from the specification document) is important and should always be shared. Likewise, it is recommended that a rationale be provided for each criteria. For example, why must the final product moisture content be 70–80%? What if it is 83%? The reasoning is that it is better to consider this question before being asked by FDA during an audit, thereby avoiding a situation in which the answer provided may not be the best.

Speaking of acceptance criteria, it is recommended that acceptance criteria be provided not only for the final product, but also for the equipment used to manufacture the product. The reason for this is that typically the equipment has not undergone full process validation and therefore its performance must also be evaluated.

**Labeling.** The labeling section simply discusses how labels will be prepared and with what information. Typically the batch number, the validation document number, the validation sequence or event number (run x of y), the sample number (or other descriptive information; e.g., sample type and/or time), and of course the date that sampling occurred are recorded on a validation label.

**Conditions.** The conditions subsection addresses the requirements for timely approval of the document. A sampling is

If any subsection of the data documentation (Section 2) is incomplete or if any deviation from the listed acceptance criteria is deemed unacceptable by the signatories, then this document cannot be approved. If it cannot be approved, timely activity closure is recommended and will require that all outstanding issues are resolved to the satisfaction of the quality representative or document termination with a cover note explaining the reasons for the termination. In either case, the parties who approved the unexecuted protocol must approve the resolution and/or the termination. Approval of all protocol explanations is required prior to the approval of a revised protocol generated to accomplish similar objectives.

**Method of Analysis.** In this particular section, some time is devoted to addressing the methods to be employed in analyzing the samples collected. Typ-

ically the actual *validated* method numbers—excluding, of course, the version numbers—are identified. For example, if chemical residue analysis will be performed using HPLC during validation, it should be identified by method name and number (e.g., HPLC method *xyz*).

**Qualification Verification.** Again, the process validation protocol should reference all items that support the validation: the procedures, personnel, methods, and equipment. This section therefore lists and summarizes the various installation, operational, and performance/process qualifications completed for the equipment used in the process validation. These qualifications should list each by equipment name and number and qualification and type. A typical verification section is illustrated below.

Equipment	Equipment number	Equipment qualification		Performance/process qualification			
		Installation qualification	Operational qualification	Cleaning validation	Ranging studies	PLC qualification	Process validation
Environmental chamber	###	###	###	###	N/A	N/A	###
Mixer	###	###	###	###	###	N/A	###
Transfer pump X	###	###	###	###	N/A	N/A	###

*Section II: Data Documentation.* Section II deals with the data documentation aspect of the protocol. It is interactive and therefore requires entries on the part of the executor(s). It captures critical variables of the validation activity, such as lot numbers of raw materials used, equipment used, and batches produced. It also captures process set points and observations as dictated by the protocol. It is suggested that each page within the data documentation section have a section devoted to the executor’s comments. Recommended sections are detailed below.

**Safety Awareness.** Safety is critical for everyone involved with a validation activity. This subsection addresses this issue, forcing the executors to acknowledge their familiarity (via signature and by date) with all of the safety aspects of the validation activity.

**Required Determinations.**

**Training.** To comply with CGMP guidelines, all persons involved with the execution of an activity covered by the protocol must have been trained on general CGMP and applicable internal procedures. This section should require all persons involved to sign and date the protocol, thereby indicating they have undergone appropriate training.

Availability of standard operating procedures. This section requires the executors to verify and list applicable operational, preventative maintenance, calibration, and equipment cleaning procedures that are available.

Materials. This section documents each component (raw materials, laminates, pouch stock, applicable lot/identifying numbers, etc.) used and the identifying numbers for each batch manufactured under the protocol.

Sample Execution. This interactive section documents activity sampling, and therefore provides proof that sampling did occur. Minimally, this section will record the sample number (if appropriate), the sample type, the sample time, and of course the individual who collected the sample. The value of this section is often overlooked.

Results. The results section is where findings are documented for each analysis. Although the acceptance criteria or specifications are listed in Section I, it is a good idea to capture the acceptance criteria in the area(s) in which the results will be listed, as shown in the next table. It is recommended that the original data be kept within the responsible or analyzing department and that the results be transcribed by the reporting laboratory to the protocol data sheets. If the need arises to compare these two sources, they could be retrieved from the data files of the responsible department.

Results: Event I

---

	Residual X	Residual Y
Sample numbers	acceptance criterion ( $\leq 10$ ppm)	acceptance criterion ( $\leq 30$ ppm)
1		
2		

---

Conclusions. The conclusions section simply captures the overall results of the activity. This section is typically completed by the executor or by someone who is technically capable of reviewing the effort and rendering conclusions. It should be concise and to the point, since the data are attached. What exactly do the data tell the audience? Was the activity a success? If not, why not? These are some of the questions that should be answered in the conclusions.

*Section III: Data Attachments.* This third and final section captures any documents that lend support to the validation effort; for example, a report that summarizes why a like-for-like substitution of a crucial piece of equipment occurred during event 2.

## B. The Validation Summary

Although it might not be a very popular opinion within the industry, it is strongly recommended that a second document be prepared that summarizes the validation event. Why prepare the summary? It simply captures the overall outcome of the validation and prevents the auditing body from having to thumb through the protocol in search of the conclusions.

As does the protocol, the summary also has a cover page that lists the protocol objectives and the conclusions—all on the front page. This document should be approved by the same departments that approved the protocol. It should also share the same identifying numbers as the protocol. A sample of a summary cover sheet is shown in [Figure 18](#).

Some other recommendations for the contents of the summary are addressed in the following sections.

### 1. Summary

This section summarizes the validation activity, citing the fact that validation occurred and for what purpose.

### 2. Discussion of Results and Deviations

This section discusses significant results and any deviations that occurred during the validation. For example, if control of a critical parameter was momentarily lost, a justification must be prepared explaining why it was lost and why this lack of control is acceptable. If a sizeable justification is prepared, then it may be wise to reference it in the summary and attach it to the validation report. The same is true of any significant results.

### 3. Conclusions

As stated earlier, the conclusions capture the overall results of the activity. The conclusions section should be concise. This section is lifted from the body of validation summary and copied onto the cover page.

### 4. Future Activities

This section makes a statement about the revalidation activities for the process and also states that any changes will be captured under the existing (validation) change control system.

## C. Validation Report

What constitutes a validation report? While it has been fairly well established that the protocol is the *planning* tool and in some cases a *communication* tool, it is recommended that the summary be used to communicate the outcome of the

## PROCESS-VALIDATION PROTOCOL

DOCUMENT XYZ

Process Validation for Manufacturing of \_ Transdermal Systems

Date (mm/dd/yy)

**OBJECTIVE:** To validate the manufacturing process for \_\_ transdermal delivery systems by verifying and documenting that the Mixing, Coating, Slitting, and Pouching processes consistently yield product that meet commercial specifications. Three consecutive commercial-scale batches (theoretical yield: \_\_ systems) will be manufactured. For each batch, final product quality will be determined by comparing the analytical results to the established commercial product specifications. Approval of the validation document summarizing this activity will indicate that Technology Transfer was both successful and complete for this process.

**CONCLUSIONS:** The process for manufacturing \_\_ transdermal delivery systems has been validated by executing three successful, consecutive commercial-scale events. Results for each event were compared to the commercial product specifications. The success of this activity demonstrates that Technology Transfer was both successful and complete.

PREPARED BY	DEPARTMENT	DATE
	(Preparer)	
APPROVED BY	DEPARTMENT	DATE
	(Owner)	
	(Support Lab)	
	(Quality Group)	

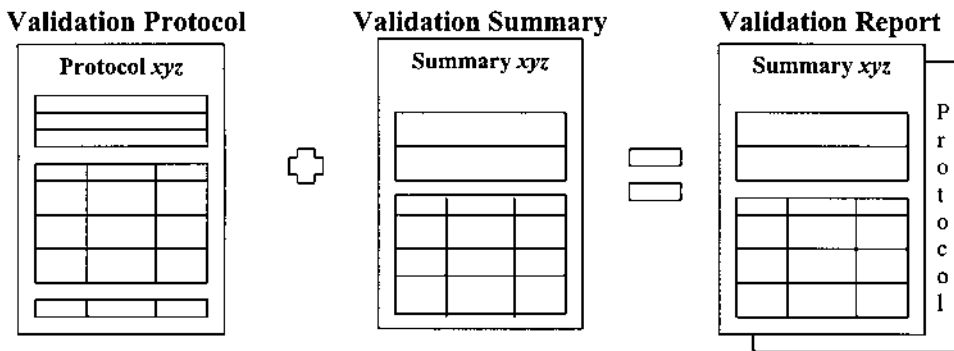
**Figure 18** Recommended summary cover page.

protocol. It is also recommended that these approved documents be combined to yield the report, which should then serve both the planning and communication purposes. This is shown in Figure 19.

## X. CHANGE CONTROL AND SUPAC

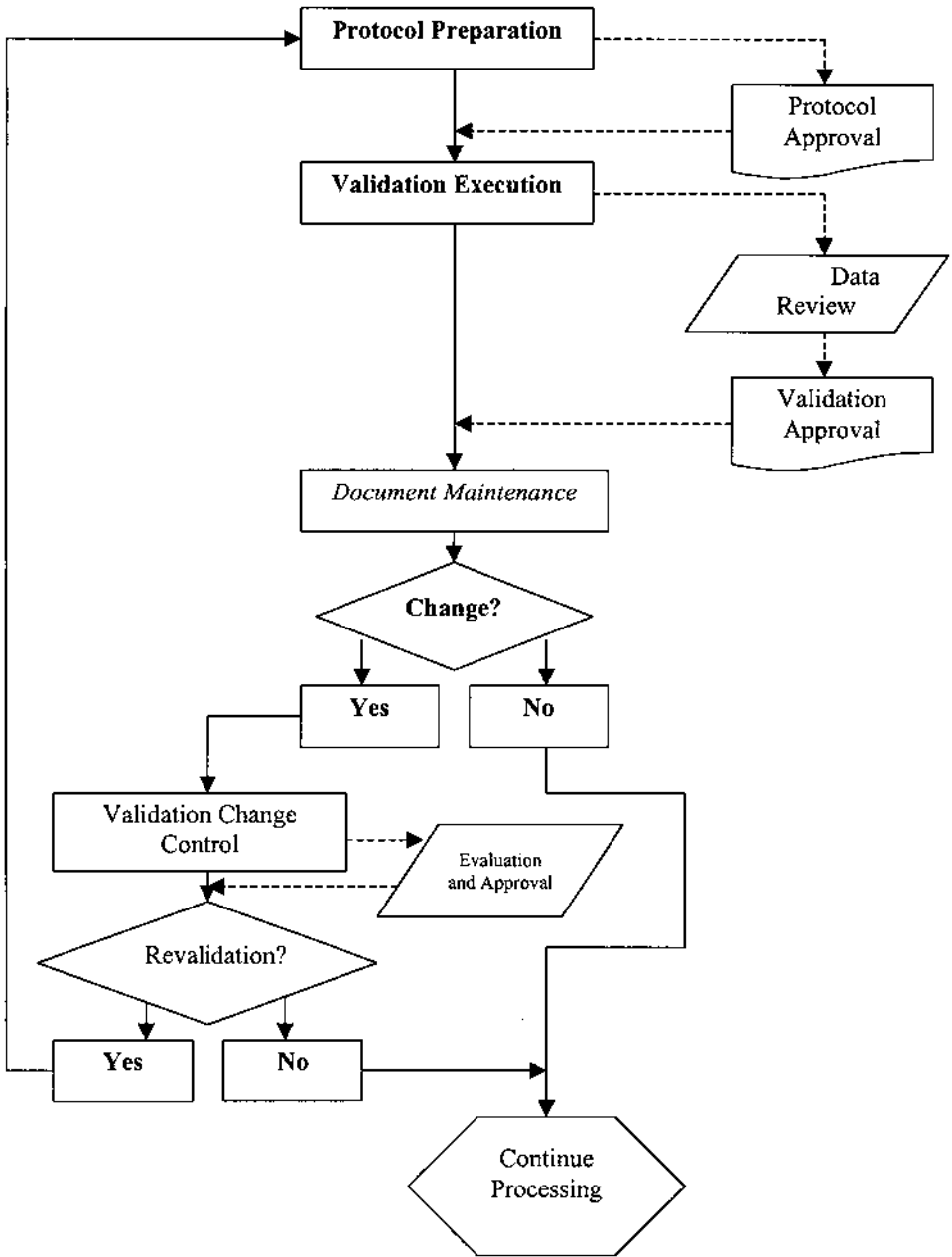
Assuming that a validation program has been successfully executed, the focus should now be on the maintenance of the validated state. A good validation program requires periodic maintenance and upkeep. Any change to a validated process likewise requires thorough evaluation and documentation. A typical decision tree for changes (requiring document preparation) to validated items is presented in Figure 20. Further, in keeping with the spirit of validation, all changes to validated processes require a certain measure of control. With a validated process, one should always have a good indication of what changes caused what affects. Proper change documentation will enable or permit correlation between changes made and the resulting process or product impact. Proper evaluation will often filter out or magnify changes that will prove detrimental to product quality.

Changes to validated processes/equipment are tracked by validation change control procedures (or simply change control procedures within some organizations). One of the tools born out of these procedures is a form for documenting such changes that highlights the level of validation required and the validation timing. A general form is illustrated in Figure 21. These forms typically require completion by the party desiring the change and typically describe the changes in enough detail so that the evaluating and approving depart-



**Figure 19** Validation documents.





**Figure 20** Validation and validation change control decision tree.

## VALIDATION CHANGE CONTROL

Change # \_\_\_\_\_

<b>Part I: Department Pursuing Change</b>			
<b>Step 1.</b>	<b>Is Process Validated?</b>	No	(Stop! Do not complete form)
		Yes	Equipment Number: _____
<b>Step 2. Provide Details of Change Below</b>			
Description of Present Condition		Description of Change	Timing For Change
			Mm /dd/yyyy (approx. implementation)
<b>Step 3.</b>	<b>Completed By</b>	<b>Department</b>	<b>Department Approval</b>
			<b>Date</b>
<b>Part II: Validation Department Assessment</b>			
<b>Step 1.</b>	<i>A. Describe impact to process</i>		<i>B. Rate impact</i>
			Minimal Significant None
<b>Step 2.</b>	<b>Is Validation Activity Required?</b>	No	(like for like only—skip to Protocol No. if appropriate)
		Yes	<b>Identify level below:</b>
		(Note: any activity conducted to assure validated process performs as expected is considered a validation activity)	
		Qualification Installation Qualification Operational Qualification Performance Qualification Revalidation	Protocol Number: _____
<b>Step 3.</b>	<b>Completed By</b>	<b>Department</b>	<b>Department Approval</b>
			<b>Date</b>
<b>Part III: Regulatory Assessment</b>			
<b>Step 1.</b>	<b>Is process filed with FDA?</b>	No (go to Part III, Step 3)	
		Yes (go to Part III, Step 2)	
<b>Step 2.</b>	<b>Change Requires:</b>	Request Permission Notification at Annual Update Other (explain below)	
<b>Step 3.</b>	<b>Completed By</b>	<b>Department</b>	<b>Department Approval</b>
			<b>Date</b>
<b>Part IV: Change Approvals</b>			
	<b>Department</b>	<b>Approved By</b>	
	(change initiator)		
	(dept where change will occur)		
	<b>Validation</b>		
	<b>Quality Assurance</b>		

Form xyz

**Figure 21** Example of validation change control form.

ments can render a decision as to whether or not this particular change can be implemented. It is then circulated to validation and quality assurance, minimally. Often these forms are circulated to other departments, such as the department in which the change will occur, and regulatory, for information, evaluation, and approval. Regulatory involvement is advisable at this stage as changes affecting processes filed with FDA will require notification.

Reputable manufacturers have been known to notify the FDA of practically any and all changes of significance to an approved process. In the past, great difficulty and confusion often resulted within the drug companies due to the fact that the severity of the changes made was very hard to classify. Additionally, the appropriate time to notify FDA of changes was always an issue. The scale-up and postapproval changes (SUPAC) guidelines came into existence to reduce the difficulty encountered with changes to approved product. These guidelines, which were developed in the mid-1990s were developed jointly by FDA and key pharmaceutical industry representatives. They in essence provide submission guidelines specific to the types of products (immediate release, control release, solid dosage, transdermal, etc.) under manufacture. They address the types of changes and the resulting submission timing—*immediate* notification versus *end of the year* reporting.

In actuality, transdermals are very similar to other pharmaceutical products. Similar to most ethical pharmaceuticals, they have attributes that must meet specifications at the end of product manufacture. In addition, various pieces of equipment are used in their manufacture. Changes to these pieces of equipment can and often do impact these key quality attributes, so what is the impact of SUPAC on transdermals? Although the guidelines for transdermals are not yet finalized, it is envisioned that the existing SUPAC guidelines will prove beneficial to transdermal manufacturers, as potential process changes can be grouped into various classes and the appropriate reporting actions taken. At this point, it matters very little that the product type is different. Using the guidelines will offer a bit more of a challenge, but hopefully the process of when to notify FDA about changes and the content of the notifications will become more and more streamlined.

## **XI. PREAPPROVAL INSPECTION ETIQUETTE**

Provided that all transdermal process validations have been successfully completed, the focus shifts to the preapproval inspection (PAI). A target date for the PAI is typically known months in advance of the actual FDA visit. It is a good idea to finalize as many of the supporting protocols as possible during this time. If a company is fortunate enough to actually execute protocols and complete the summaries before the PAI, it is recommended that representative copies of the

approved validation reports be sent to the officiating FDA office prior to their actual visit. If the reports are not complete (i.e., summaries not approved), the possibility of supplying unexecuted protocols should be explored. Again, this will provide FDA with an opportunity to become familiar with the firm's documentation, thereby permitting questions to be formulated in advance. While this may not seem beneficial to the industry, it may actually serve to decrease the amount of time that FDA spends in a given facility, potentially lessening the likelihood of an unwanted discovery.

It is also important that these producing companies understand that any data and reports submitted to FDA are pictorial representations of the submitting company. If a company puts together a sloppy submission package with sloppy development data, sloppy validation data, and so on, then that company should not be surprised if approval is not granted. Industry must therefore make every effort to assemble the very best package possible for submission to FDA.

## **XII. CONCLUSIONS**

Companies that fall under the CGMP umbrella must understand what FDA wants. First, its primary concern is to assure that drugs and devices made by these companies are fit for consumption. These products must exhibit proper quality and efficacy (CFR 21), thus the many years of clinical trials entailing in vitro and/or in vivo challenges, bioavailability determinations, extensive development data including the generation of stability profiles, the assessment of impurities in the drug product, the numerous files containing these development data, and finally, the documentation that the equipment and process have been acceptably qualified and *validated*. This is also true of transdermals.

One of the lessons learned is that validation is not cheap; there is no way industry can gain assurance that a process will always be under control with just a single event. Validation, by definition, requires multiple events to fully deliver the confidence that the validated item will perform as expected. Equally important are the preliminary trials leading up to the validation activity.

Many validation personnel understand the need for and the benefits of performing trials and stress testing, but do their companies share their understanding? While many may have a solid understanding, they seldom share the desire to fund prevalidation trials. This is true because many of these trials cannot be simulated and therefore performed with actual product.

To summarize, process validation is a requirement imposed by the FDA. It is referenced in 21 Code of Federal Regulations, Part 210 and 211 [8]. It is extremely important that each organization have a good understanding and interpretation of the regulations and do everything it can justify in the pursuit of process validation. This justification should consider the resources (human,

dollar, time) required and of course be weighed against the potential benefits to be derived from the often strenuous undertaking. It is equally important that the need for validation be communicated throughout each operating department within the organization.

Documentation is critical in the validation framework. Simply going through the motions and not doing a thorough job of documenting may void the validation effort, no matter how good the execution may have been. If you cannot produce a document upon request, FDA's attitude is that the work has not been done.

Just how do drug and device manufacturers assure that their validations are compliant with the CGMP regulations? One approach would be that a firm should first do an adequate job of interpreting the term *validation*. Next it should logically plan and document its interpretation (in a protocol), along with any justifications. The next step should be to assure that all equipment and facility components have been adequately qualified and that those qualifications have been documented and filed in a retrievable location. This same approach pertains to process validations. Finally, the recommendations shared in this chapter—though not for the entire reading audience—may be of use to a majority of the readers. Using these recommendations should put the manufacturers in a better regulatory position with respect to their validations.

## REFERENCES

1. *United States Pharmacopeia* (USP). vol. 24. General Discussion/Pharmaceutical Dosage Forms, p. 2116.
2. RxList Monographs (*Transdermals*); [http://www.rxlist.com/cgi/generic2/estradtd\\_cp.htm](http://www.rxlist.com/cgi/generic2/estradtd_cp.htm), p. 3.
3. Brittain, H. G. Validation of analytical methodology. *J Val Tech* (May 1997).
4. Nash, R. A. Introduction. In: *Pharmaceutical Process Validation* (1993).
5. Doty, L. A. *Statistical Process Control*. p. 240 (1991).
6. Neal, C. Technology transfers in the pharmaceutical industry. *cGMP Comp* (April 1998).
7. Neal, C. Equipment cleaning validations for transdermals. *J Val Tech* (Nov. 1997).
8. Guideline on the General Principles of Process Validation (May 1987).

# 9

## Validation of Lyophilization

**Edward H. Trappler**

*Lyophilization Technology, Inc., Warwick, Pennsylvania, U.S.A.*

### I. INTRODUCTION

In an ideal world, validation would begin with and parallel product research and development activities. Validation for lyophilized products occurs more often during scale-up to manufacturing. Under growing regulatory pressure and the realization of the greater benefits, however, validation activities are being undertaken while the product is along the developmental pathway. There are also circumstances for which validation is required for existing commercial products, either because of changes requiring additional study, or to meet current regulatory standards. This presentation will approach validation as an integral part of developing a new product. Appropriate application of the principles discussed may be applied for either a change-control procedure or for revalidation, based on specific needs.

### II. ORGANIZING FOR THE VALIDATION

Components of a comprehensive validation program include equipment qualification, together with product and process validation. Utility, flexibility, and ease of management are advantages of assembling each validation activity, study, or test as a distinct, independent entity. The equipment qualification portion focuses on the equipment and is valid for the processing of any number of products. Conversely, the process for each product is unique and applies to only one product. Therefore, process validation is specific for that product.

A validation protocol can effectively be arranged as individual sections. Organizing the validation project into discrete activities can be advantageous

for ease of developing and executing the studies. This is of particular benefit when validating a sophisticated, complex process such as lyophilization. In this manner, validation activities are also more manageable. Responsibility for each individual part is clearly defined and more effectively implemented by individuals best suited for each part of the validation. For example, a member of the engineering staff would be more qualified to implement an installation qualification, rather than validate the process. Just as a research scientist would be best suited to validate that process, rather than complete an installation qualification. The validation studies could also be easily scheduled and completed at appropriate times during either installation of a new lyophilizer or during development and scale-up of a lyophilized product. Managing a change-control program as discrete sections is much easier and more effective than in a massive documentation package.

Development of a new lyophilized product with attention to validation requirements is easier to integrate into a production environment compared with undertaking further developmental studies at the time validation is attempted in manufacturing. For example, in designing the lyophilization process, completing process studies at the boundaries of a process parameter range would be appropriate at the time stability studies are prepared. Such an approach results in greater safety and efficiency in the parameter selection and results in a more robust process. This notion of establishing a proven acceptable range was first introduced by Chapman as the proven acceptable range (PAR) approach to process validation, and is suitably applied to lyophilization [1].

Validation for an existing product requires constructing a development history profile. This profile should start with preformulation data, span product and process development, and include commercial product manufacturing. In reconstructing the development history, the most challenging undertaking is justifying the product formulation and process design. This is particularly difficult in circumstances with commercial products that have been developed before the awareness of the benefits of validation.

When a new product is in the development phase, a comprehensive report needs to be assembled before scale-up as part of the technology transfer to manufacturing. This report addresses the starting raw materials, including drug substance, excipients, and packaging components, along with formulation and process design. Each facet of the product manufacturing needs to be included, from formulating procedures through final packaging requirements. In-process and finished product quality attributes must also be defined. The report needs to clearly explain the scientific rationale and justification for the formulation and manufacturing procedures.

This development report is a crucial reference for integrating a new product into a manufacturing operation. Acceptance criteria for any validation study would be based on product and process requirements outlined in the develop-

ment report. The report provides an invaluable reference for change-control program management and troubleshooting.

Equipment qualification is best considered at the time of equipment specification and selection. The advantages include more effective project management, ease of completing the validation package, and speed of bringing the equipment on-line. Equipment requirements and performance are based on the needs of the product, as characterized during product development.

As with specifying and purchasing any new piece of equipment, well-written equipment specifications include validation activities for qualifying the equipment and assuring it meets the requirements for producing the intended products. Defining testing and documentation needed for factory acceptance testing (FAT) at the vendor's facility is also a useful contractual agreement.

## **A. Sources of Information**

Sources for information include research and development (R&D), engineering, clinical supplies manufacturing, quality control, and regulatory affairs groups. Technical information such as the physicochemical character of the active substance and product information, stability data, along with process development data, and finished product criteria should be available within the development report generated by the R&D group. Specific information on the equipment design and performance for the Installation and Operational Qualification (OQ) portion of a validation protocol should be available from the engineering department. Other engineering references include maintenance and calibration procedures. Operating procedures covering product loading and operation of the lyophilizer may be available within manufacturing documentation. These would include loading procedures and arrangement of product trays within the lyophilizer. Finished product-testing methods for the active ingredient, reconstitution, and residual moisture should be available from the development scientists, analytical development group, or may already exist as standard testing methods within quality control. The regulatory affairs staff should be consulted for commitments made in regulatory filings and communications to regulatory agencies.

## **B. Recommendations For a Validation Protocol**

The differing circumstances under which a validation study is prompted often dictate the best approach to be used. Agreeably, prospective validation, for which the validation studies are all completed and approved before shipment of any product, is preferred. There are however, opportunities to complete certain validation studies when producing product intended to be administered to patients. Such circumstances may arise during clinical manufacturing, when exten-



sive testing is completed. In such a circumstance, validation is concurrent with producing these materials. In addition, when implementing validation studies on an existing marketed product to bring the operation up to current regulatory expectations, concurrent validation would also be appropriate. Retrospective validation would be applied to a review of historical data of an existing process and product. Examples would be the review of the lyophilization processing data, finished product batch release test data, and stability data from the commercial stability testing program.

The design of the validation testing and the composition of the protocol reflect the circumstances under which the study is conducted. For retrospective validation the “test” may be statistical analysis of batch release data, such as assay, pH, physical appearance, residual moisture, reconstitution time, and constituted solution appearance. This retrospective process validation would be intended to demonstrate that the product is of consistent quality. A critical review of the processing conditions in a retrospective validation may consist of a “test” comparing actual processing conditions during lyophilization with ideal parameters. This not only shows adherence to the defined processing conditions, but also demonstrates process reproducibility.

Concurrent validation studies may be used during clinical manufacturing and scale-up activities. Additional testing or an increased number of samples, as when demonstrating batch uniformity for a large production lyophilizer, may be conducted as a concurrent validation study. In addition to finished product testing, short-term accelerated stability may be appropriate before actually releasing the batch for distribution. Long-term stability studies at the recommended storage conditions, up to the length of the clinical study or the intended shelf life of the product would also be appropriate.

Although there are circumstances when retrospective or concurrent validation may be warranted, prospective validation is certainly preferred. This entails the testing, review of the data, and approval of the validation package before releasing product for distribution and use. Identifying the target process parameters and a proven acceptable parameter range, along with demonstrating consistent product quality and stability, would be valuable before introducing the product into a manufacturing environment. It could also decrease the amount of time that often seems necessary for getting a new product from development through manufacturing, because alterations during scale-up may be minimized.

Conceptually, there is a logical progression for the various validation studies. In purchasing a new piece of equipment to produce a lyophilized product, specifications, verification of the design during the engineering phase, in addition to simply conducting a factory acceptance testing, would be part of the first phase of validation. This combination of Design Qualification (DQ) and Factory Acceptance Tests (FAT) is particularly appropriate for more sophisticated systems, such as for a large-scale manufacturing equipment. The Installation Quali-

fication (IQ) would be implemented during the installation and start-up of the lyophilizer to assure that the lyophilizer is installed properly and all necessary support “systems” are in place. These range from basic utility requirements to standard operating procedures (SOPs). Operational Qualification (OQ) studies, conducted on successful completion of the IQ, assure that the equipment is capable of implementing the processing parameters to successfully produce the product, as defined during development.

For a process validation, all studies may be completed during the development phase. These studies would correlate the product formulation, presentation, and lyophilization-processing parameters with finished product attributes. In addition, the reproducibility of the process would be demonstrated along with the consistency of finished product attributes. Batch uniformity studies during the first batches being integrated into manufacturing are often the last leg in the sequence of validation protocols for bringing a product to market. Depending on the supporting data available from earlier studies, limited or short-term accelerated stability may be sufficient.

### **III. COMPOSING THE VALIDATION PROTOCOL**

The design of the validation studies and the format used for the actual protocols can have a substantial influence on both implementing the protocols and maintaining a change-control program. Breaking the validation project into small, discrete tasks makes both managing and implementing the studies easier.

The use of format in which each activity, function, or test is a complete, stand-alone task and document yields numerous advantages. These advantages are evident during the writing, reviewing, and implementation activities. Having discrete documents also allows specific and focused testing that may be appropriate under a change-control program.

#### **A. Preparation of the Protocol and SOPs**

Each activity to be performed as part of the equipment qualification (EQ) and the entire process for the IQ and OQ can be organized into discrete functions and documents. For an EQ, whether being simply a FAT or including a DQ for a more complex system, it is useful to have a stand-alone document that focuses on equipment design and construction aspects. During the IQ, the reviewing and verification of utility connections, piping of the refrigeration and heat transfer system, reconnecting the vacuum system, rewiring of the control system, start-up and testing may be organized into distinct documents for each activity. This “modular” approach becomes more effective and efficient as the complexity of the procedures and equipment increases. Each aspect of bring a lyophilizer on-

line or integrating a new product into a manufacturing environment often involves several individuals or departments. Correlating distinct activities of the protocol into small sections makes communication between individuals and departments more manageable. For example, the project engineer responsible for installation of a new lyophilizer may use a mechanical contractor to reconnect the piping and connect the utilities, and use an electrical contractor to connect the control system wiring. In such a case, a documentation package covering each activity may be issued and completed for each part of the project involving each contractor. A documentation package organized in such a manner is also a useful tool for project management.

Such an approach is also applicable for product and process validation. Considering the ranges of formulation aspects, such as the acceptable pH range, a focused study to correlate the pH, phase transition temperature, and finished product aspects on processing, would be well suited as a distinct protocol. This specific protocol may parallel studies already conducted during development. Another example is establishing the proven acceptable range for the processing parameters. Identifying such ranges is accomplished by processing the product at extreme shelf temperatures, chamber pressures, and times, following the PAR approach as described earlier.

Whether during the development of a new process or product, or in designing an appropriate protocol for a new piece of equipment, organizing the protocol and identifying the studies to be conducted is the first strategic step. During product development, there are often many unknowns that exist when the protocols are written. These can span the testing methods for release of the drug substance to finished release specifications. The same applies to developing the qualification protocols for a new piece of equipment at the time the specifications are written. There may be design changes that will influence the EQ documentation. In the real world, alterations, ranging from slight refinements, to major changes frequently occur.

## **B. Establishing Acceptance Criteria**

The selection of acceptance criteria is dependent on the circumstances under which validation is being undertaken and requires judicious consideration. Challenges to the equipment, for example, may depend on whether the equipment is first being installed or whether qualification is being completed for an existing lyophilizer currently in use. If the equipment is new, the acceptance criteria based on the performance requirements that are identified within the equipment specifications would be warranted. The advantage of acceptance criteria based on stated equipment capabilities is that any process that is within the performance capabilities of the equipment could be used for processing product. For testing an existing unit in production, however, the most rigorous processing conditions would be a justifiable test challenge. The limitation of test challenges,

based on the most current processing conditions, although rigorous, is that if a process for a new product is outside of the parameters tested, then additional testing or qualification at the new parameters would be necessary.

Details of constructing validation protocols, designing studies, and establishing acceptance criteria will be presented in each section of this chapter. In considering the approaches discussed in this presentation, it is important to consider what would be appropriate and useful in achieving a high level of control for the project at hand. The validation needs to encompass testing and documenting of what is critical for gaining a high degree of assurance that the process is well defined and reproducible, the procedures are adequate and appropriate, and that the equipment is suitable for completing the process. In addition, it is a valuable opportunity to collect useful information for implementing a change-control program. Validating for the sake of simply documenting information in a protocol, not having a clear understanding of what is necessary, or creating a voluminous collection of information because more is better should be avoided. As a general rule, do what is necessary and do it well.

For some studies, as in the OQ, references will be made to common performance capabilities of equipment. These are intended to be examples, rather than standards. A few general notes are appropriate. Most importantly, acceptance criteria needs to be based on a justifiable scientific rationale. This is applicable whether qualifying an existing piece of equipment for commercial product manufacture or validating a product and process during clinical manufacturing. Selecting appropriate processing ranges to be encompassed within the validation has a major long-term effect in manufacturing. For example, when the range of residual moisture is adequately determined and correlated with long-term stability during development, then any batch in manufacturing exhibiting moisture within the boundaries of that range would be acceptable. If the residual moisture was beyond the boundary, then there would be concern about adequate stability, and the batch may not be released. Adoption of such a philosophy provides clear and reasonable ranges for product manufacture. There is also little question of what should be done when a batch is outside the proven acceptable range. This eliminates a scenario of doing additional testing, perhaps even stability testing, when there is a question of what a suitable envelope of processing conditions or product quality aspects would be for a manufactured batch. This notion of establishing a proven acceptable range, or PAR approach, becomes a valuable asset in a manufacturing environment.

#### **IV. EQUIPMENT QUALIFICATION**

Equipment Qualification (EQ) is a useful endeavor when the lyophilizer is a complex and sophisticated system. Large-scale manufacturing units commonly include multiple automated support operations. These may include steam-in-

place (SIP), clean-in-place (CIP), in situ filter integrity testing, and automated- or robotic-loading systems. The lyophilizer may also be designed for unique product-processing requirements, as in processing mixed solvents, or unique dosage forms, such as quick-dissolving tablets. An EQ may include both the design qualification (DQ) and the factory acceptance testing (FAT). The DQ encompasses a review of the product and processing requirements and justification of the equipment design, construction, and performance capabilities. It is also useful as a structured guide for reviewing the engineering documentation from the vendor. This includes not only equipment blueprints, but also control logic and program structure for an automation system. Completing such a review during the engineering phase of the project provides an excellent opportunity to verify that the specifications are suitable. The FAT is a series of tests at the supplier's factory before shipment of a new lyophilizer. The FAT includes verification that the equipment's final design, construction, and performance are as anticipated when compared with the equipment specifications. This assumes that the specifications are based upon current or anticipated needs for processing a product. In the absence of specific processing needs, the reference would be the specifications agreed to between the vendor and purchaser.

Activities within the FAT are complementary to that of the IQ and OQ implemented at the final installation site. This would include verification of the engineering documentation, construction, and assembly of the lyophilizer, along with demonstration of the equipment performance.

### **A. Scope and Objectives**

For the acquisition of a new lyophilizer, the FAT comprises a series of tests to ensure that the lyophilizer meets the performance expectations identified within the purchase specifications and are necessary for its intended use. The intent is to measure and verify the performance capabilities of the lyophilizer before shipment to the end user.

### **B. Early Project Activities**

As part of a comprehensive specification package, incorporating the qualification requirements in the equipment specifications package to the vendor assures that proper attention is given by both the vendor and purchaser. These validation requirements include the FATs along with control system validation, and perhaps even extending to the Installation and Operational Qualification. Identification of the testing to be done at the factory to complete the FAT protocol allows sufficient planning for both manpower resources and time at the vendor's facility. Validation of the automated system controlling the lyophilization process, along with the complementary processes, such as SIP and CIP, needs to be

started at the control system design and software development stage of the project. This follows the life cycle [2] approach that has become common industry practice for validation of computer automation systems.

Part of the FAT that comes before any actual performance testing is the review and verification of the equipment design. This is sometimes completed as a separate task and is often referred to as a Design Qualification (DQ). This step, whether as a separate DQ or as part of the FAT entails a review of the engineering documentation to verify that the equipment will meet the requirements of the specification before construction and assembly of the lyophilizer. Such a review includes the general layout of the equipment, piping arrangements for the CIP and SIP systems, refrigeration and heat transfer fluid system drawings, electrical elementary schematics, and P&ID drawings. This review of the engineering drawings should be documented and become part of the validation package.

### C. Preshipment Testing

Equipment performance tests completed during the FAT involves testing to demonstrate that the equipment functions and performs as specified. The tests may mimic those planned as part of the OQ to be conducted at the final installation site. These tests are useful both in assuring that the equipment is constructed according to the specifications and also that the performance is adequate. It is important to acknowledge that utility supplies may affect the equipment performance; therefore, the acceptance criteria may be different than in the OQ that will be conducted after the equipment is installed.

Often duplicating the testing for an OQ, test encompass function, control capability, and performance for freeze-drying and support processes, such as SIP and CIP processes. The testing regimen should include specific tests as listed in Table 1. Complementary functions such as sterilization and, if supplied,

**Table 1** Equipment Qualification Testing

---

Shelf heating rate  
Shelf cooling rate  
Shelf temperature control  
Condenser cooling  
System evacuation rate  
Pressure control  
Leak test  
Sublimation rate  
Condenser capacity

---

cleaning should also be included with equipment having SIP and CIP capabilities. Testing of the loading and unloading would be appropriate with systems where an automated-loading system is provided by the lyophilizer manufacturer.

This testing program is useful as part of the validation package, along with being part of the equipment acceptance. *Circumventing the testing at the vendor's facility should be avoided, no matter how complex or unique the final installation.* Frequently, correcting a problem or making adjustments to meet the specifications is easier, less expensive, and faster if completed at the vendors facility, rather than in the field during installation, or correcting during validation. In addition, successfully completing the FAT does not negate the need to complete a comprehensive IQ/OQ at the final installation site. Factors, such as assembly of the lyophilizer at the final installation site and differences in utility supplies, warrant testing before bringing the unit on-line for manufacturing product. The more complex and unique the equipment design and final configuration, the more such efforts are necessary to assure the success of the project. Some parts of the IQ could be completed at the factory and not repeated after installation. Such items may include instrument and hardware documents, testing of the control system, and verification of as-built drawings, to cite a few examples.

## **V. INSTALLATION QUALIFICATION**

The IQ is often the first validation activity completed when the lyophilizer arrives at the final installation site. Implementation of the protocol may begin as the lyophilizer is being installed. For example, verification of the electrical wiring and piping may be accomplished as part of the assembly activities. The appropriate approach to completing the IQ is dependent on the specific circumstances of the project.

### **A. Scope and Objectives**

The Installation Qualification consists of a description of the lyophilization equipment, a system hardware and component list, the documentation of the installation procedures, and the equipment start-up and operator training. The IQ also includes references to the purchase specifications, engineering review, and SOPs. The objectives are to assure that the equipment design and construction are appropriate for the intended use, it is installed properly, the utilities are suitable and adequate, and that procedures are in place for proper maintenance and operation.

### **B. Equipment Description**

The description of the lyophilization equipment provides a general overview of the lyophilizer, the installation site, operation, and functions. The description also identifies the major components of the system. From the listing of the major

components, a more specific description of each item provides greater detail. Such information is highlighted in Table 2. This data becomes an integral part of the change-control system for the equipment hardware. The major components of the lyophilizer that should be included are the refrigeration units, heat transfer fluid, heat transfer circulation pumps, heater elements, primary vacuum pumps, secondary vacuum pumps, system valves, and the control instrumentation.

### C. Installation Activities

Documentation of the installation can also be included within the IQ section of the validation package. Part of this documentation may take the form of an installation checklist. This checklist would include each specific activity necessary for the installation of the lyophilizer, who completed and checked the work, and the date the work was completed. These activities would include assembly of the various lyophilizer parts (if dismantled at the factory for shipment) and the connection to utility supplies. In some circumstances, these activities and the associated documentation may have been completed during the commissioning of the equipment.

In addition to the early project activities of the engineering review and factory testing completed as part of the FAT, certain parts of the Installation Qualification should also be planned well in advance of receiving the equipment. These include the utility verification, physical installation of the lyophilizer, start-up, and training. The utility verification, identifying the quantity, quality, and source of the utilities, is best completed during the initial phase of the project and before operation of any of the lyophilizer systems. These encompass electricity, cooling water, process gases, sterilant, and discharges for the lyophilizer. The listing in Table 3 is of common utility supplies.

Physical installation of the lyophilizer includes the rigging into place and connection of the subsystems. With large-sized units and those with external condensers, such connections are fairly involved projects in themselves that in-

**Table 2** Hardware Description Data

---

Manufacturer  
Model number  
Serial number  
Part number  
(assigned by lyophilizer vendor)  
Utility requirements  
Capacities  
Reference  
(equipment drawings)

---



**Table 3** Common Utility Supplies

---

Electric

Voltage, phase cycle, amps  
(control circuit power)

Cooling water

Temperature, pressure, flow rate

Compressed air

Pressure, flow rate, quality

Compressed gas (nitrogen)

Pressure, flow rate, quality

---

clude mechanical, electrical, and refrigeration mechanics. After installation is complete, most vendors provide a service technician to start up the system and provide training as part of commissioning the equipment. Such activities need to be documented and may be included within the IQ portion of the protocol.

## **VI. OPERATIONAL QUALIFICATION**

The Operational Qualification (OQ) focuses on the equipment, rather than the process. Although not associated with any specific process, the OQ is a series of tests that measure performance capabilities and demonstrate the ability of the lyophilizer to complete critical processing steps. Functions of the lyophilizer, such as cooling and pressure control, are process related. They are, however, focused on measuring the performance capabilities of the equipment, rather than demonstrating any processing capabilities relating to producing a particular product.

### **A. Scope and Objectives**

The OQ demonstrates the equipment performance for the range of processing functions at the installation site. The tests performed may be expanded to compare with those completed as part of the FAT at the vendor's facility. Additional activities, such as CIP and SIP process development and validation, are also performed after the IQ has been successfully completed.

#### **1. Measuring Equipment Performance**

Although the testing at the factory may have demonstrated the performance capabilities of the equipment, such tests need to be performed at the final installation site. Different utility supply capacities, such as cooling water and steam,

influence the equipment performance. These tests also verify that the utility supplies are adequate and meet the demands of the operating system. This testing is particularly valuable for large systems disassembled and shipped as smaller packages, when the unit is reconstructed at the installation site. Testing is necessary to demonstrate that installation was completed properly, and that the equipment still meets the performance levels previously demonstrated.

## 2. Verification of System Capabilities

The OQ evaluates each equipment function and the capacity to meet the performance standards. Reducing the lyophilization process into each function also has advantages for managing a change-control program. For example, one test would focus on cooling rates used for the freezing step, while a separate test would be implemented to evaluate the heating function used during primary and secondary drying. The advantage of having a separate and distinct testing protocol for each process step is that there is a specific testing protocol for each discrete equipment function used to complete a step in the process. Constructing the protocol using such a format later becomes an advantage when a significant change is made to the shelf-cooling equipment or there is a question about performance capabilities. A detailed and specific protocol could be implemented to demonstrate that there is no significant change to the system-operating performance. Considering each function of the equipment for each step in the process allows segregation of each equipment function, with a respective test that demonstrates a specific performance capability.

## B. Equipment Performance Tests

Performance capabilities and capacities can be evaluated using a separate test for each function of the lyophilizer. These tests focus on the operation of selected subsystems and the capacity for the specific functions during lyophilization. These subsystems include the heat transfer system, condenser, and vacuum system. An overview for testing of each major subsystem is presented in the following sections. Also included are examples and illustrations for performance ranges. These examples, however, do not, reflect the capabilities of a specific lyophilizer, nor are they intended to suggest any industry standard.

### 1. Heat Transfer System

The heat transfer system provides cooling required for freezing the product and the subsequent heat needed to establish rate of sublimation. Temperature control is required over the entire process, from the time the product is loaded onto the lyophilizer shelves until it is removed after stoppering. Therefore, cooling and

heating rates, along with control at set point, and temperature uniformity, must be tested.

Maximum cooling and heating rate tests are intended to demonstrate the optimal performance of the equipment. The cooling rates, defined as an average of the change in temperature per unit time, are measured from room temperature to the ultimate achievable freezing temperature. Heating rates are measured from the lowest to the highest operating temperature for the lyophilizer. For a lyophilizer currently in use, the acceptance criteria may be the average rate across a temperature range that exceeds the current process requirements by a few degrees. Test results are expressed as an average rate of change, as measured at the shelf inlet. Because the performance of the lyophilizer is strongly dependent on the specific design, acceptance criteria vary. It is common, however, to be able to achieve average cooling and heating rates in the range of  $0.5^{\circ}$ – $10^{\circ}$ C/min.

Shelf temperature uniformity across any one shelf and all of the shelves of the lyophilizer needs to be within an acceptable range to assure batch uniformity of the dried product. The temperature at any location is compared with either the mean of the measured values or the temperature indicated on the controlling instrument. The allowable range is dictated by the reference used, with tighter tolerances used when comparing the actual with the mean of the measurements. The stated capability for shelf temperature uniformity by many of the lyophilizer vendors is  $\pm 1^{\circ}$ C at steady-state conditions. Appropriately completed under no-load conditions, these functions may again be demonstrated under load conditions during the sublimation–condensation test.

## 2. Condenser

Measuring the cooling rate and ultimate lowest temperature of the condenser is useful in generating baseline data for future reference, such as monitoring the condition of the refrigeration system. As with the shelf cooling, the rates will vary based on the size, type and number of refrigeration units on the system. The ultimate condenser temperature necessary is dependent on the solvent system used to solubilize the material to be dried. For a completely aqueous solvent system, a maximum allowable temperature is commonly  $-50^{\circ}$ C. For processing some organic solvents, the necessary condenser temperature is dependent on the solvent being processed. For example, ethanol vapors must be chilled to below  $-115^{\circ}$ C before condensation and solidification will occur, whereas tertiary butyl alcohol requires to be only slightly colder than room temperature.

In the sublimation–condensation test, the condensation rate, and ice load capacity are demonstrated. In these tests, the actual performance is more critical than the baseline test of cooling rate and ultimate temperature. The rate of condensation, expressed as kilograms of ice per hour, becomes a limit to the pro-

cessing parameters that may be used in design of the lyophilization cycle. The results of the ice capacity test become a limit to the product batch size.

### 3. Vacuum System

Similar to the cooling rate and ultimate temperature tests for the condenser, evacuation rates and lowest achievable pressure are baseline tests that indicate the performance of the vacuum-pumping system. Typical evacuation rates permit reaching 10 $\mu$ m Hg within 20–30 min. The lowest achievable pressure is commonly 20 $\mu$ m Hg or less.

Associated tests to include are leak rate and vacuum integrity tests. Both tests are based on the pressure rise of a sealed chamber and condenser that are isolated from the vacuum pumping system. A detailed presentation on the subject is covered in various technical publications on vacuum technology [3,4]. Each of these tests, briefly described in the following paragraphs, is well suited to be stand-alone protocols.

The leak rate test is a baseline measurement that is intended to determine the presence of leaks in the freeze-dryer chamber and condenser. The test is implemented with the chambers being clean and dry, and with low levels of outgasing. Eliminating any vapors that may outgas and contribute to a pressure rise requires that the test should be done only after the system has been maintained at a low pressure for several hours. Acceptance criteria often used are the specifications agreed to by the equipment vendor and end user. The values for this test most often quoted by equipment vendors is  $6 \times 10^{-4}$  Pa-L/min ( $6 \times 10^{-4}$  Pa-L min<sup>-1</sup>), equivalent to  $4.5 \times 10^{-6}$  mmHg-L/min ( $4.5 \times 10^{-6}$  mmHg-L min<sup>-1</sup>) for a completely assembled system. These values, however, are arbitrary and have little technical significance other than illustrating the relative tightness of the lyophilizer at the time the test is conducted. The standard may be expressed as units of pressure per unit time for a system of given volume or units of pressure and volume per unit time that would apply to any size system.

The vacuum integrity test is an in-process method used in manufacturing after the completion of sterilization and before loading product. Results of this test compare with a different standard than the baseline leak test because there is significant outgasing present from prior sterilization. Because every system and sterilization procedure may be different, a study to establish an acceptable value that accommodates outgasing of water vapor is necessary. Justifying an acceptable number is accomplished by correlating a rate of pressure rise that includes any contribution of outgasing of vapors from residuals left over after the sterilization process. Therefore, this requires that a test study is conducted after the sterilization process has been validated, because sterilization conditions may influence the amount of outgasing that occurs. Results of this study yield a value expressed as a pressure increase per unit time, such as Pascal, millime-

ters, or microns per minute. Although there have been discussions on the topic published, there is no industry standard established that is based on either empirical data or a justifiable scientific rationale [5,6].

### **C. Control Functions**

Whether a control system comprises distinct instruments for nominal control functions and process monitoring, or an integrated control system, a nominal set of control function tests are necessary. The tests described encompass both controller capability and equipment performance. These tests may be completed during the FAT as part of a separate computer system validation.

#### **1. Shelf Temperature Control**

Different from the achievable heating and cooling rate capabilities, shelf temperature control tests combine the system capabilities in implementing a range of cooling and heating rates and control at a specific set point across the operating range of the system.

For cooling and heating, minimum and maximum rates are challenged. These rates may be based on either anticipated processing conditions or the vendor's stated equipment performance over the operating range of the system. Rates for both cooling and warming may range from a minimum of 0.1°C/min to maximum of 1.0°C/min.

Shelf temperature control tests demonstrate the system's ability to maintain steadystate shelf temperature used for the freezing and drying process and should be within an acceptable range near a target set-point. If the acceptance criterion is other than the vendor's stated operating range, then control points used for the test must envelop the temperature ranges to be used for processing. Equipment capabilities range from  $\pm 1^\circ$  to  $\pm 5^\circ\text{C}$  from the target set point, as measured at the control point. Typical manufacturing units range within  $\pm 3^\circ\text{C}$ .

#### **2. Pressure Control**

The pressure control capability, critical as a process parameter, needs to demonstrate the accuracy and precision of pressure control across the range anticipated for the lyophilization cycles. This range can be a pressure as low as 20 $\mu\text{m}$  Hg (0.026 mbar) or as high as 1600  $\mu\text{m}$  Hg (2.08 mbar). The results of the test are compared with the target values at low, intermediate, and high pressures. Acceptance criterion is stated as an acceptable range near the three target set points. An acceptance criterion of  $\pm 10$   $\mu\text{m}$  Hg ( $\pm 0.013$  mbar) is readily achievable.

#### **3. Process Monitoring**

Defining the process as critical parameters of shelf temperature, chamber pressure, and time dictates that monitoring these conditions is performed with suitable accuracy and precision. Product temperatures, being less critical because of

intrinsic limitations, are also commonly monitored. The ability of the monitoring system to reflect the actual process status is assured by an appropriate calibration program. It is appropriate to complete a comparison of values measured if multiple instruments are used for monitoring the same conditions or if data is transferred from a recording instrument or PLC to a computer workstation. This activity is normally conducted as part of the control system validation and needs to be completed before starting the OQ testing, because those instruments will be used for control and data collection.

#### 4. Sequencing Functions

With an automated control system, verifying the sequencing functions may be appropriate during the OQ testing. The first step is verifying the interfaces to the field devices, such as pumps, motors, and valves, and their proper operation. This should include operation of proportional control valves.

This verification may have been completed separately as part of the control system qualification and, therefore, would not be necessary during the OQ studies. In verifying the control sequence functions, the hardware engaged for each step and the successful progression through the process, are compared with that identified from the control system flowchart. Whether completed during the OQ, or separately during control system validation, is of little importance. However, it is preferred that the control system be qualified before implementing any of the OQ testing, especially any integrated control functions, such as the lyophilization process tests. As noted in the introduction, computer control system validation has unique requirements for validation and would best be accomplished as a separate study. The PDA Technical Report No. 18, Validation of Computer-Related Systems, provides a useful reference for control system validation [2].

#### 5. Integrated Process Control Functions

Integrated control functions encompass the lyophilization process itself, along with alarm functions and fail-safe responses to out-of-range process conditions. Critical parameters of shelf temperature, chamber pressure, and time, and the success in controlling these parameters within an acceptable range, are demonstrated during the actual lyophilization of material. For ease in completing the testing and as a precursor to implementing a process with test material, the lyophilization cycle may be run using an empty chamber with alarm function tests and fail-safe responses challenged. During this “dry run” the logical responses of the control system, along with the behavior of the physical equipment components, are demonstrated. Response to alarm conditions, such as the shelf temperature and chamber pressure, may be altered by physically forcing such conditions. For example, directly engaging the heaters would cause the shelf temperature to warm above the allowable target set point range. Engaging the

refrigeration compressor when the shelves are at the target set point would cause the shelf temperature to fall below the range, also instituting an alarm condition. Fail-safe responses would also be tested in a similar manner. Table 4 highlights some of the critical parameters that would be appropriate to test during such a simulation.

#### D. Process Testing

The basic functions are demonstrated and performances measured in the collection of tests described in the preceding sections. The principle elements of the system functions are complete; the next step is to demonstrate that the discrete functions can be combined as an integrated process. Process testing combines functions tested separately in the preceding steps of the OQ studies using a model product. Such a study challenges the integrated control capabilities, orchestrating the functions and capabilities of each component of the system to implement actual processing parameters for a complete lyophilization cycle. This combines the equipment performance and control capabilities, implementing variable processing conditions that encompass the dynamics of the process. In concept, the test bridges functions of the individual system components and the control instrumentation to the system successfully manipulating the environmental conditions to within reasonable processing parameters. This testing also provides an opportunity to demonstrate batch uniformity capabilities. It is important to note that this process testing is independent of any particular processing parameters and any specific product presentation. Rather, it is a series of tests designed to demonstrate the capability of the equipment to reproducibly implement the lyophilization process and yield consistent product qualities, independent of the location of the product within the lyophilizer. Identification of suitable locations for product monitoring and sampling during performance qualification studies that are product specific may be derived from these studies.

##### 1. Product Uniformity

As in any pharmaceutical batch operation, batch uniformity is paramount. Studies by Greiff [7] have shown that when lyophilizing a 3-ml volume of a 2% serum albumin solution in a 10-ml-tubing vial there is a measurable effect of

**Table 4** Process Fail-Safe and Alarm Tests

---

High shelf temperature  
Low shelf temperature  
High chamber pressure  
Low chamber pressure

---

location within the lyophilizer on the amount of ice sublimed and the residual moisture. His studies also quantified the patterns of distribution for vials with low, intermediate, and high residual moistures varied with the shelf temperature, the shelf position, and elapsed processing time. In this specific example, the effect of processing conditions, time, location of the vial on the lyophilizer shelf, and the influence of heat transfer through a clear Plexiglass door, are well demonstrated. This study illustrates how such factors as location of the product on the shelf warrants demonstrating that such influences can be controlled within acceptable levels.

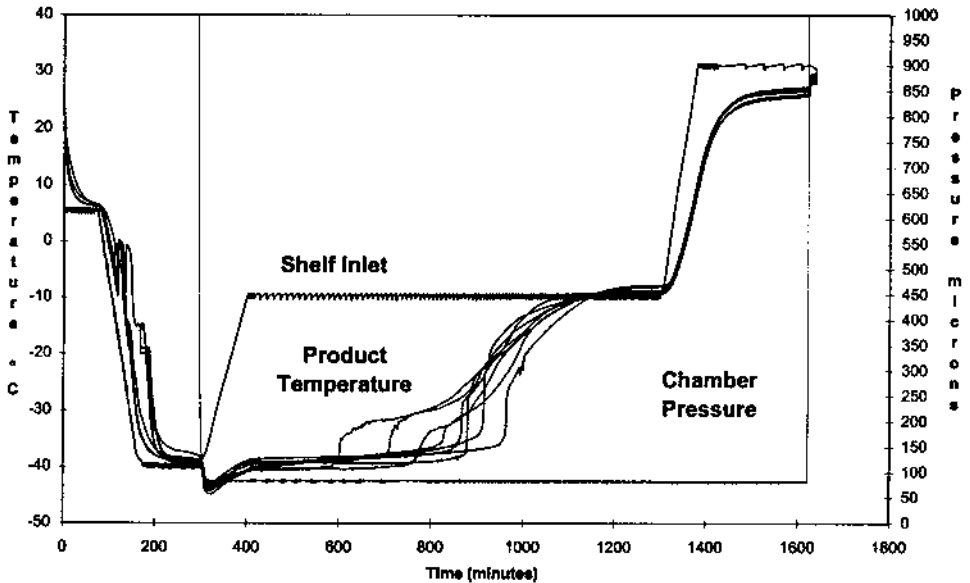
Mapping of the chamber is an effective method of quantifying any effects of location and surrounding environmental influences, such as differences in heat transfer. The result of such a study can be used to identify appropriate locations for monitoring and product sampling during actual product validation studies, as well as to demonstrate sufficient batch uniformity.

These trial runs also verify adequate process parameter control of shelf temperature and chamber pressure under load conditions. The batch size and process parameters do not necessarily need to duplicate those for any actual product. Rather, it provides the opportunity to design an appropriate model to challenge the equipment capabilities. Several models have been proposed, ranging from a placebo of a specific product formulation to a combination of mannitol and arginine, in vial sizes from 10 ml to 100 ml [8].

Lyophilizing multiple batches of a model product provide a challenge to demonstrate the equipment's performance capabilities under load conditions. Process parameters of shelf temperature, chamber pressure, and time are compared with target values. In addition, product response in the areas expected to impart the greatest variation, such as the perimeter of the shelf, can also be assessed. The range of product temperatures and the distribution of times when monitored vials achieve the end point of drying can also be compared. Variation in the time when there are sudden increases in product temperature, referred to as a "break" in the product temperature, can also be influenced by the vial type and location of the thermocouple placement [9]. This can be effected by differences in mass transfer of the water vapor through the dried product [10]. [Figure 1](#) illustrates the variation in product temperature for a formulation containing protein, mannitol, and glycine at various concentrations. Therefore, the significance placed on any variation in product temperature and time the temperature breaks along with conclusions drawn from such data, needs to account for such inherent influences.

Finished product attributes, such as physical appearance, reconstitution times, and residual moisture, are more effective in quantifying the magnitude of any variation owing to product location inside the lyophilizer. Differences in vial content of the active ingredient, assuming that filling of the vials started as a true solution that is inherently homogeneous, would not be affected by loca-





**Figure 1** Temperature variation during drying for a 2-ml-tubing vial with combinations of a protein-mannitol-glycine formulation.

tion. Any differences in purity, presence of degradation products, and changes to the active ingredient content from the beginning to the end of the filling operation would be monitored during the initial scale-up batches. Any differences can also be monitored as a matter of routine by sampling the first and last vials placed in the lyophilizer.

An advantage in utilizing a model formulation is that excipients that are not significantly influenced by rate of freezing may be selected, but will indicate subtle differences in measurable in-process characteristics, such as temperature, and attributes of dried product, such as residual moisture. The excipient, concentration, and fill volume all influence the variation in physical structure and density and, therefore, affect the rate of mass transfer of water vapor during sublimation [11]. For example, dilute solutions of excipients, such as mannitol, polyvinylpyrrolidone and simple ionic salts in the range of 5–12% w/v, solidify with a dense, uniform structure, regardless of the rate at which the material is cooled during freezing. Significant differences in structure can be observed with excipients, such as dextran, sucrose, and lactose, when solidified at different rates of cooling during freezing [12]. These differences may be improperly interpreted, thereby providing false indications of any variation caused by position

because of variations in both product temperature and residual moisture. These materials, therefore, should be avoided.

## VII. LYOPHILIZATION PRODUCT QUALIFICATION AND PROCESS VALIDATION

Lyophilization is a method of preservation in which the conditions necessary for the process are dependent on the characteristics of the starting material. The finished material is dependent on the processing conditions used for freezing and freeze-drying. This requires that the physiochemical character of the material be well defined and understood to develop a suitable process. For routine processing, the consistency of the starting material may dictate the level of success during processing. Such data is a prerequisite to designing an appropriate process. There may also be characteristics of the material that allow quantifying the level of success of processing. As an example, x-ray diffraction may be used for a material that may crystallize under certain processing conditions. Therefore, the morphology may be monitored to assess the level of success in achieving the desired processing conditions and resulting product characteristics. In addition, the quality and adequate characterization of the starting material must be considered when undertaking a validation study, and are discussed within the following sections.

Definitions for validation published in the *Federal Register* in May, 1996 emphasize the distinctions between process and validation [13]. *Process suitability* is described as “. . . established capacity of the manufacturing process to produce effective and reproducible results consistently.” *Process validation* is defined as “. . . establishing, through documented evidence, a high degree of assurance that a specific process will consistently produce a product that meets its predetermined specifications and quality characteristics.” Section 211.220, describing process validation again, includes demonstrating reproducibility of the process as a requirement.

The application of lyophilization is employed for the preservation of materials that are normally chemically unstable in solution. Demonstrating that a process produces product of suitable quality characteristics implies that such minimum product quality level is inherent at the time of release and throughout the shelf life of the product. Preservation of quality characteristics is then an inherent result of the process as well as a requirement of the product. This places a greater emphasis on correlating product stability to processing conditions. This emphasis is carried through the portion of this chapter relating to process development. Applying these validation concepts to lyophilized processes and products, the significance of development activities and the suitability of validation during development becomes apparent.

## A. Preformulation Data

As part of the preformulation activities, investigations include physiochemical character, purity, solubility, stability, and optimal pH studies. In preparation for clinical studies, potential product formulations considering route of administration and solution stability are also studied. Unique to dosage form development studies for lyophilized products, thermal analysis of the drug substance and product formulations are also necessary. Data generated during this phase of product development is useful for future development activities, along with validation.

For lyophilized drug products, the active substance purity and morphology, formulation procedures, excipients used, and initial concentration may affect behavior during processing and dried material stability, with a wide variety of examples in the literature. For example, certain  $\beta$ -lactam antibiotics may solidify to an amorphous or crystalline morphology. Each different form exhibits different physiochemical properties, such as solubility and stability [14]. In addition, pH may be an influencing factor in the phase transition of the substance [15]. The presence of certain excipients may also alter the morphology of the active substance [16]. Degradation pathways involving hydrolysis, common for products that require lyophilization, are also significant. For biopharmaceuticals, numerous biochemical reactions such as hydrolysis, oxidation, deamidation,  $\beta$ -elimination, and racemization play an important role in the stability of the final product [17]. It has also been reported that residual levels of an impurity in mannitol as low as 0.1% w/w was responsible for the degradation of a polypeptide during storage [18]. There are often a significant number of critical characteristics that need to be considered in the manufacturing of lyophilized products. These include the inherent variability in quality and purity of the active ingredient and product formulation along with the robustness of processing methods developed and subsequently validated.

Development studies, summarized within a distinct report on the physiochemical aspects, drug substance attributes, and finished product characteristics, become critical parts of the validation package. Such data is also valuable for future integration into a manufacturing operation. This includes the scientific rationale for formulating and bulk-handling procedures, lyophilization processing parameters, finished product analysis, and stability requirements.

## B. Development Activities

Development activities encompass drug substance characterization, formulation design, packaging selection, and process development for manufacturing. Each of these aspects influence the lyophilization process. For a drug substance, upstream processing and quality aspects of the starting material need to be quantified. These quality aspects include both assay and purity. In particular, levels of

residual solvents, intermediates, as well as degradation products are of interest. In development of drug products, formulation design, and procedures, a suitable container and closure, and the lyophilization process need to be studied during product development. Stability of the bulk solution and constituted product, along with stability in the dried state, and effects on processing all need to be considered in the formulation design. Once the quality of the drug substance, optimal formulation, and product presentation have been identified, design of the lyophilization process can be completed.

Acknowledging that validation is an intimate part of development, considerations for each major phase of the development activities will be reviewed. This review starts with studies of the drug substance and progresses through finished product testing.

## 1. Drug Substance

The physicochemical character of the active ingredient directs the formulation design and selection of excipients for the finished product. If, for example, the drug substance has a propensity to form either an amorphous or crystalline phase, the method of freezing and the character of the material need to be assessed during development. From a theoretical basis, a crystalline form is more thermodynamically stable than a material solidified during freezing in the amorphous form. For example, the solid-state decomposition of cefoxitin sodium can occur at different rates. The amorphous form yields a 50% loss of the active ingredient within 1 week at accelerated storage conditions of 60°C. The crystalline form exhibits less than a 10% loss in 8 weeks under the same conditions [19]. Investigating the physicochemical character of the active material, therefore, needs to be studied during development. In such circumstances where there may be different morphological forms of the active ingredient or excipients used in the formulation, the influence of processing conditions is critical, as discussed later in this chapter.

The specific physicochemical character of the material may be a useful means for verifying reproducibility during the validation studies. Materials that will form a crystalline structure and have good bioavailability and stability may be formulated with mannitol as an excipient, where both the active compound and mannitol readily crystallize. However, some substances will alter the morphology of other excipients or the drug substance. These differences may be quantified with analysis by x-ray diffraction. Peptides and globular proteins tend to inhibit the crystallization of some excipients that would otherwise crystallize. An example of this is the affect of human growth hormone (hGH) on the morphology of glycine and mannitol [20]. In such circumstances, monitoring the physicochemical characteristics of the substance can be useful in qualifying the formulation design of the finished product. It may also be a useful tool in assessing process reproducibility and product consistency.

Another factor that needs to be considered is the purity profile of the active substance. For example, a synthesized drug substance precipitated out of an organic solvent may contain trace amounts of the crystallizing solvent. Even minute levels of residual solvent or other impurities can affect the measured phase transition of the material [21]. Therefore, the amount of allowable trace solvents or impurities and their effect on product behavior during processing need to be evaluated in early development studies. This may also be appropriate as a monitoring concern during validation.

For biological preparations, upstream purification of peptides and proteins may use combinations of organic solvents and acids to elute the substance from the chromatography column. A peptide may orient itself in either an  $\alpha$ -helical or  $\beta$ -pleated sheet configuration, depending on the presence and concentration of an organic solvent. As a consequence, the behavior in solution or during the freezing process may differ substantially for each conformation. Trace amounts of solvents and acids may also affect the behavior of the substance in solution and during freezing. Such details of the requirements, sensitivities, and behavior of the active substance need to be defined in the scheme of development and evaluated during validation activities. An appropriate purity profile should be established and monitored to provide control over the starting raw material. Specification for residual substances, including processing solvents, chemical intermediates, precursor fragments, along with microbiological quality are also necessary. Acceptable levels of degradation products from upstream processing and bulk solution stability also need to be established during development and may be used during scale-up and full-scale validation studies to demonstrate an adequate level of control during processing.

When given the active substance characteristics determined during development acceptance criteria for the validation studies can be established. These criteria will demonstrate the consistency of the dried material processed within a proven acceptable range in the development phase and adequacy of the scale-up to manufacturing. To be comprehensive in this presentation, numerous aspects, although not necessarily applicable to all products, are presented as illustrations in the following sections.

In circumstances during which the active ingredient or any excipient may crystallize, monitoring of the morphology in evaluating the dried product may be warranted. If differences in solubility, reconstitution rate, or stability are imparted by the morphology, then a quantitative method should be included for assessing finished product attributes. Methods of analysis for dry powder include infrared spectroscopy, nuclear magnetic resonance, particle morphology, thermal analysis, and x-ray diffraction [22].

Degradation products that may form through hydrolysis, oxidation, or specific biochemical reactions should be monitored by an appropriate analytical method. Polymerization, aggregation, and denaturation levels may be included in the finished product and stability-monitoring protocols if warranted.

## 2. Finished Product Formulation

The solubility and stability based on pH are important in identifying the acceptable pH range for the product formulation. In some instances there is a compromise between solubility and stability, either for the bulk solution or dried product. For example, a 1 pH unit shift from pH 5 to pH 4 for penicillin increases the solubility along with opportunistic degradation reactions by 1 log [23].

The effect of bulking agents and their interactions should be studied and understood during development. Along with measuring the degree of crystallization, this may provide a quantitative measurement that may be useful for demonstrating process reproducibility and product consistency. Formulations containing excipients that tend to crystallize, such as mannitol or glycine, may be more useful.

The effects of the variations in pH or the influence of any buffering system also needs to be studied. Any influence on the behavior of the active ingredient or excipients during the freezing and the phase transition on warming should be considered. As an example, in a biopharmaceutical formulation containing glycine, adjusting the pH with sodium hydroxide forms sodium glycinate. The behavior of sodium glycinate in the formulation may be different from that expected of glycine in the free acid form. Such differences in physicochemical nature and phase transition temperature have been evaluated [24].

Unless there is a specific and critical function of an excipient, an assay is not normally considered to be necessary during validation. There are, however, formulations for which an excipient is critical to the function of the active ingredient. For example, for some *in vivo* imaging agents, the reduction of stannous chloride is necessary in the coupling of a radiolabeled compound. For amphotericin B, deoxycholate sodium is used as a solubilizing agent and needs to be at a minimum concentration to assure that the drug is completely soluble on reconstitution. The concentration of the excipient in these two examples is critical and an assay would be appropriate.

## 3. Determining Thermal Characteristics

To establish the shelf temperature necessary to completely solidify the product during freezing, the required temperature necessary to achieve complete solidification is determined by thermal analysis early in product development. In addition, if the formulation undergoes crystallization, such behavior during freezing and the optimal processing parameters used for cooling the product are critical and need to be well defined.

With low-temperature thermal analysis, the phase transitions during cooling and warming are critical data necessary to justify the scientific rationale for the process and identify appropriate processing levels. This is not only necessary for determining the ultimate temperature for cooling the product during freezing, but also for determining the maximum safe threshold temperature during pri-

mary drying. In certain instances, the temperature during primary drying is critical for the product in the presence of ice and early in secondary drying. For example, the solid-liquid phase diagram for sucrose, presented by MacKenzie, indicates that there is a glass transition at  $-32^{\circ}$  to  $-34^{\circ}\text{C}$  when the sucrose is in the presence of ice and before any significant desorption [25].

Commonly used methods for low-temperature thermal analysis needed for lyophilized products are highlighted in Table 5. Each of the methods available for low-temperature thermal analysis has particular advantages. Although the nature of the material sometimes dictates the most applicable method, confirming analysis by a second method is a valuable tool in fully understanding the behavior of the material under freezing and freeze-drying conditions. Differences in measurements and observations and the effect on the drying conditions designed for processing warrant the use of confirming methods.

#### 4. Assessing Bulk Solution Stability

Assay methods for monitoring any degradation products may be used to justify the time limits for bulk storage. This time would include the period from when the product is formulated to the end of the filling operation. Because most lyophilized formulations do not contain a biological preservative, microbiological quality before sterilization by filtration must also be monitored. The unfiltered solution bioburden would include microorganisms and endotoxin levels.

Besides monitoring bulk solution qualities by conventional analytical methods, measurement of the phase transition may also be warranted. Slight differences in the nature of the formulation owing to aging, undetected by typical analytical methods, may influence the phase transition of the product formulation. For example, absorption of carbon dioxide from the air over an extended time period may cause a pH shift, consume one component of a buffering system, or promote degradation. For a peptide or protein with both a hydrophilic and hydrophobic nature, alterations to desired secondary, tertiary, or quaternary

**Table 5** Methods of Low Temperature Thermal Analysis

Method	Principle	Indication
Differential scanning calorimetry (DSC)	Change in molecular heat capacity	Glass transition and eutectic melt
Electrical resistance (ER)	Change in electrical conductivity	Glass transition or eutectic melt
Freeze-drying microscope	Direct microscopic observation	Fluid flow and structural collapse

structure may develop. As a result, polymerization, aggregation, or denaturation may occur. Any one of these may change the phase transition and alter the solidification temperature or finished product characteristics. If such an opportunity exists, then the conformational changes need to be monitored to justify and validate the allowable bulk storage conditions, such as temperature or atmospheric conditions, including a suitable time.

## 5. Justification of Processing Parameters

During the process development phase, ideal processing conditions should be devised as target parameters to yield desired finished product qualities and acceptable stability. Those target processing parameters (shelf temperature, chamber pressure, and time) that are safe, effective, and efficient are selected and studied during the development phase. A temperature for completely solidifying the product during freezing is established based on results of thermal analysis studies.

Thermal analysis data also dictate the maximum product temperature allowable during primary drying. Shelf temperatures and chamber pressures are then selected to assure that the product remains below this critical threshold temperature during primary drying. Secondary drying conditions necessary to achieve the desired residual moisture content are also identified. Determination of these processing parameters requires numerous process studies and corresponding stability studies to define optimal conditions.

The result of such process development studies would be a definition of target-processing parameters for shelf temperature, chamber pressure, and time. These parameters encompass the time from when the product is loaded onto the shelves of the lyophilizer until the product is stoppered and removed. In addition, the rates of change from one shelf temperature to another also need to be defined. These rates of change, referred to as ramps, include cooling rates during freezing, warming of the shelf at the beginning of primary drying, and the transition from primary to secondary drying.

As an example, the complete process description for methylphenidate hydrochloride, a product containing mannitol in which the active ingredient has a phase transition of  $-11.7^{\circ}\text{C}$ , may be described as outlined in [Table 6](#) [26]. Material processed according to the predetermined conditions would be expected to yield product of acceptable quality, purity, efficacy, and stability. Reproducibility of these parameters is demonstrated by comparing the actual processing parameters for any one batch with the ideal target parameters identified as a result of development studies. Evaluation of the finished product qualities and assessment of the stability over the desired shelf life demonstrate that the processing conditions are suitable and appropriate. Implementing the same process conditions and achieving the same finished product qualities and stability confirms that the process is reproducible and the product qualities are consistent.



**Table 6** Definition of Target Process Parameters

Process step	Shelf temperature (°C)	Rate (°C/hr)	Chamber pressure	Time (hr)
Product loading	5°		Atmosphere	2
Cooling rate		0.5		
Freezing	-20°		Atmosphere	4
Ramp to primary drying				
Primary drying	65°	0.5	80 µm Hg <sup>a</sup>	
Ramp to secondary drying			80 µm Hg	
Secondary drying	40°	0.5	80 µm Hg	8

<sup>a</sup>The pressure reported ranged from 210 to 15 µm Hg; 80 µm Hg was selected as a reasonable level for discussion.

It is also appropriate that the range of processing conditions deemed to be acceptable produce product of adequate quality and sufficient stability. These include a range for the shelf temperature during freezing and drying, the chamber pressure for drying, and time at secondary drying conditions. Selection of the suitable ranges for the processing conditions must be based on empirical data from developmental studies or capabilities in a manufacturing environment, rather than simple arbitrary selection.

Following an experimental design approach for developing a matrix of variables is undoubtedly a preferable method for conducting experimental studies. This type of an approach to process validation may be suitable for experimental design, but becomes extremely cumbersome when reproducibility of the process and consistent product quality is to be demonstrated. In the absence of the many studies required to fulfill a complex matrix, a simpler matrix based on the edges of a defined range would be reasonable and scientifically valid.

Process conditions that affect both the product temperature and rate of drying are shelf temperature and chamber pressure. For these process conditions, target parameters, along with suitable ranges above and below the target parameters, need to be studied and defined during development. Therefore, validating the process requires demonstrating that if conditions existed during which the process was completed at the extremes of the range for these conditions, the finished product would have the same qualities as if the batch were processed at the target parameters. Because both the shelf temperature and chamber pressure are independent parameters, the various combinations of both conditions at the extremes and at the target would establish a PAR [1]. The goal of the process validation studies for a PAR is to verify that if the process was completed within

any combination of the two variables, then the finished material would be of consistent quality and stability.

The design of a series of studies based on the variables of shelf temperature and chamber pressure would encompass, minimally, permutations of high and low conditions for each. Demonstration of reproducibility is also an objective during validation, such that three batches processed at the target conditions would also be necessary. This, therefore, would require a minimum of seven batches: three at the target parameters to demonstrate reproducibility and four for the combinations of high and low conditions.

In addition to the shelf temperature and chamber pressure, the time to complete secondary drying will influence the residual moisture content of the dried material. If we assume that a target residual moisture content is known, the validation studies should also encompass a range of time at the secondary drying conditions necessary to achieve the desired residual moisture. The range of time could be incorporated within the three batches at the target shelf temperature and chamber pressure. As an illustration, and using the cycle defined for methylphenidate described in Table 6, the variations in shelf temperature, chamber pressure, and time in secondary drying are presented in Table 7.

The parameters outlined in Table 7, consisting of high shelf temperature and high chamber pressure would provide the upper level of processing conditions. During freezing, the shelf would be controlled at the maximum or warmest temperature at which solidification would occur. During primary drying, the warmest shelf temperature and highest chamber pressure would result in the greatest amount of heat supplied to the product. This increased amount of heat

**Table 7** Varied Process Parameters for a Proven Acceptable Range

Process condition	Product loading	Cooling rate	Freezing	Ramp to primary drying	Primary drying	Ramp to secondary drying	Secondary drying
Shelf temperature							
High	10°C	0.5°C/hr	-15°C	0.5°C/hr	60°C	0.5°C/hr	35°C
Target	5°C	0.5°C/hr	-20°C	0.5°C/hr	65°C	0.5 °C/hr	40°C
Low	0°C	0.5°C/hr	-25°C	0.5°C/hr	70°C	0.5°C/hr	45°C
Chamber pressure							
High				100 µm	100 µm	100 µm	100 µm
Target	Atmo- sphere	Atmo- sphere	Atmo- sphere	80 µm	80 µm	80 µm	80 µm
Low				60 µm	60 µm	60 µm	60 µm
Time	2 hr		2.5 hr		7 hr		6 hr 8 hr 10hr

would be expected to result in a greater rate of sublimation, warmest product temperature, and possibly the shortest processing time. In considering the effect during secondary drying, the high levels would provide potentially higher rates of desorption and, therefore, the lowest residual moisture content. The end result should be the slowest freezing rate, fastest drying rate, warmest product temperature during the process, and lowest residual moisture.

The matrix of varied processing conditions outlined in Table 7 encompasses the coldest shelf temperature and highest chamber pressure. In this study, a decrease in the rate of sublimation, compared with the foregoing cycle conditions is anticipated because the shelf temperature is lower and a resulting decrease in the amount of heat energy to support sublimation would occur. However, there would be a contribution in heat transfer by the increased chamber pressure, compared with the target-processing conditions. Although the rate of sublimation and desorption would be lower than that of the first study, they may be greater than those expected for the target parameters.

A higher chamber pressure would provide greater efficiency in heat transfer from the shelf. Any increase in the overall amount of heat transfer relative to the parameters outlined in Table 7 would depend on the specific parameters selected. The greatest anticipated effect would be on the product temperature owing to the increase in chamber pressure. This effect would be strongly dependent on the specific processing pressure. For example, the effect of a 20- $\mu\text{m}$  increase is greater at a target pressure of 80  $\mu\text{m}$  than it would be at a target pressure of 400  $\mu\text{m}$ . For these sets of processing conditions, product temperatures during each process phase, rates of drying, and residual moisture content would be intermediate compared with the other studies.

As compared with a higher pressure and lower shelf temperature outlined in Table 7, drying rates with the reversed conditions of lower pressure and higher shelf temperature would be expected to be slower than the conditions at target shelf temperature and chamber pressure. Compared with those conditions, freezing would be expected to require more time. Primary drying rates would also be reduced because heat transfer rates would be less, product temperatures lower, and residual moisture higher.

The longest times for the product to reach completion for each cycle phase would result from the combination of a lower shelf temperature and chamber pressure. In this study, the principal objective is to demonstrate adequate times allocated for each portion of the process, even under the conditions where the heat transfer was low and times were longest compared with the target parameters. Here the heat transfer would be lowest and, therefore, the freezing and drying require the longest time. The product temperature would also be expected to be the lowest compared with the other processing conditions. Processing under these conditions of the least heat supplied to the product demonstrates that there is sufficient time designed within the cycle parameters to accommodate such variations in rates of drying.

Proven acceptable ranges of processing parameters during primary and secondary drying would be expected to yield some range of residual moisture. This range would result from different variables of shelf temperature, chamber pressure, as well as the conditions for desorption in secondary drying. The least significant influence is often variations in time. However, depending on the characteristics of the formulation and the association of residual moisture in the product, the allowable range of time in secondary drying needs to be correlated with the resulting residual moisture contents. This should be accomplished during the developmental phase. Sequential stoppering or use of a sample extraction device to determine the change in residual moisture content over time is a convenient method for measuring the extent of moisture decrease. Another method used during development activity to justify the time necessary in secondary drying is generating a desorption isotherm. Examples, such as the sorption isotherms for polyvinylpyrrolidone (PVP) have been presented [27]. Methods for conducting such studies have also been more recently described [28].

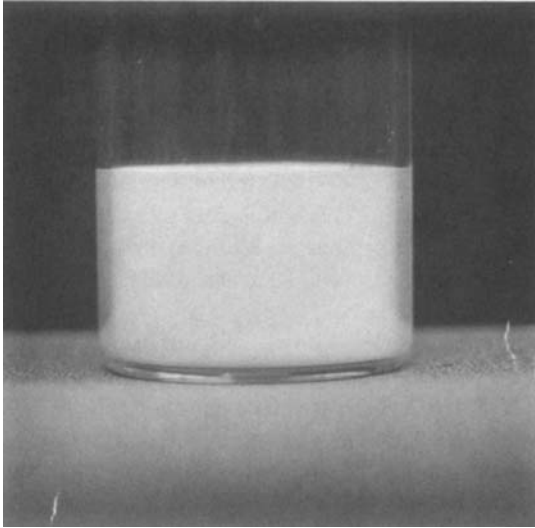
## 6. Finished Product Attributes

There are unique dried material quality attributes associated with lyophilized materials. The term dried material is used loosely here and meant to encompass both lyophilized drug substances and intermediates, as well as drug products intended for administration. Quality attributes are nearly identical for each type of material, whether drug substances or finished drug products. Stringent microbiological quality is also a requirement for sterile drug products, whereas an acceptable level of bioburden might be appropriate for a bulk drug substance.

In addition to chemical or biological assay and specific requirements for a finished product, such as those for parenteral administration, the condition of the dried cake also needs to be identified. These include the physical appearance of the dried cake and the ease with which the dried material goes back into solution.

The results of a successful and effective freeze-drying process is the retention of the physiochemical attributes of the starting solution and, preferably, retention of the structure established during freezing. Assay of the constituted solution assures the preservation of the desired activity present in the starting material. Assay of multiple samples of dried material is used to demonstrate content uniformity.

*Physical Appearances.* The appearance of the dried material should be uniform in structure, color, and texture. A material having ideal pharmaceutical elegance would be a dense, white cake, with fine, uniform structure as illustrated in [Figure 2](#). As described earlier, successful freeze drying results in the retention of the structure established during the freezing step. If the material forms the desired appearance upon freezing and that structure is retained throughout the



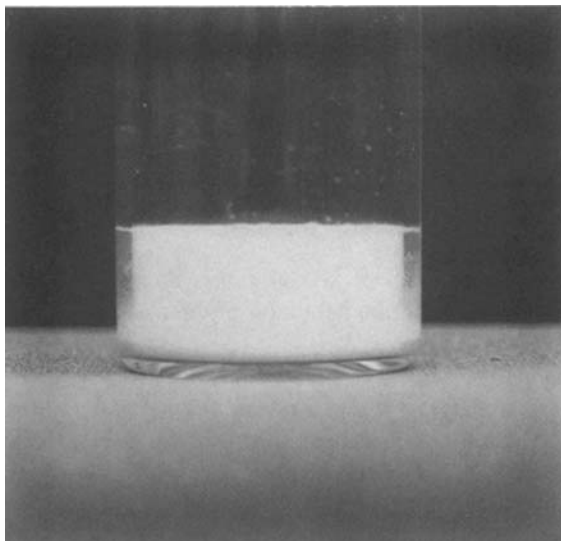
**Figure 2** A cake that is uniform in appearance, texture, and color, occupying the original volume of the liquid fill epitomizes a “pharmaceutical elegance” for a lyophilized product.

drying, then the process should yield a finished product with an appealing appearance.

For some formulations, particularly those with low solids content, the dried cake may shrink from the original volume on drying, as evidenced in the sample in [Figure 3](#). Such shrinkage is dependent on the concentration of the starting solution, nature of the active ingredient, and the amount and type of excipients used. However, the shrinkage is often uniform throughout the batch. Although not always achievable, the design of an ideal formulation would lead to a dense cake, uniform in color and texture, with good physical strength and friability [29].

A decrease in total volume or localized loss of structure can also be associated with a condition referred to as collapse [30]. This condition occurs when the frozen or partially dried material exceeds the phase transition at which the material may again become fluid. Samples of dried product in [Figure 4](#) illustrate the appearance of the cake structure caused by extensive collapse.

With the material becoming fluid, there is a loss of desired structure established during freezing, often coincident with entrapment of water. This entrapment of water into relatively larger masses may also prevent adequate desorp-

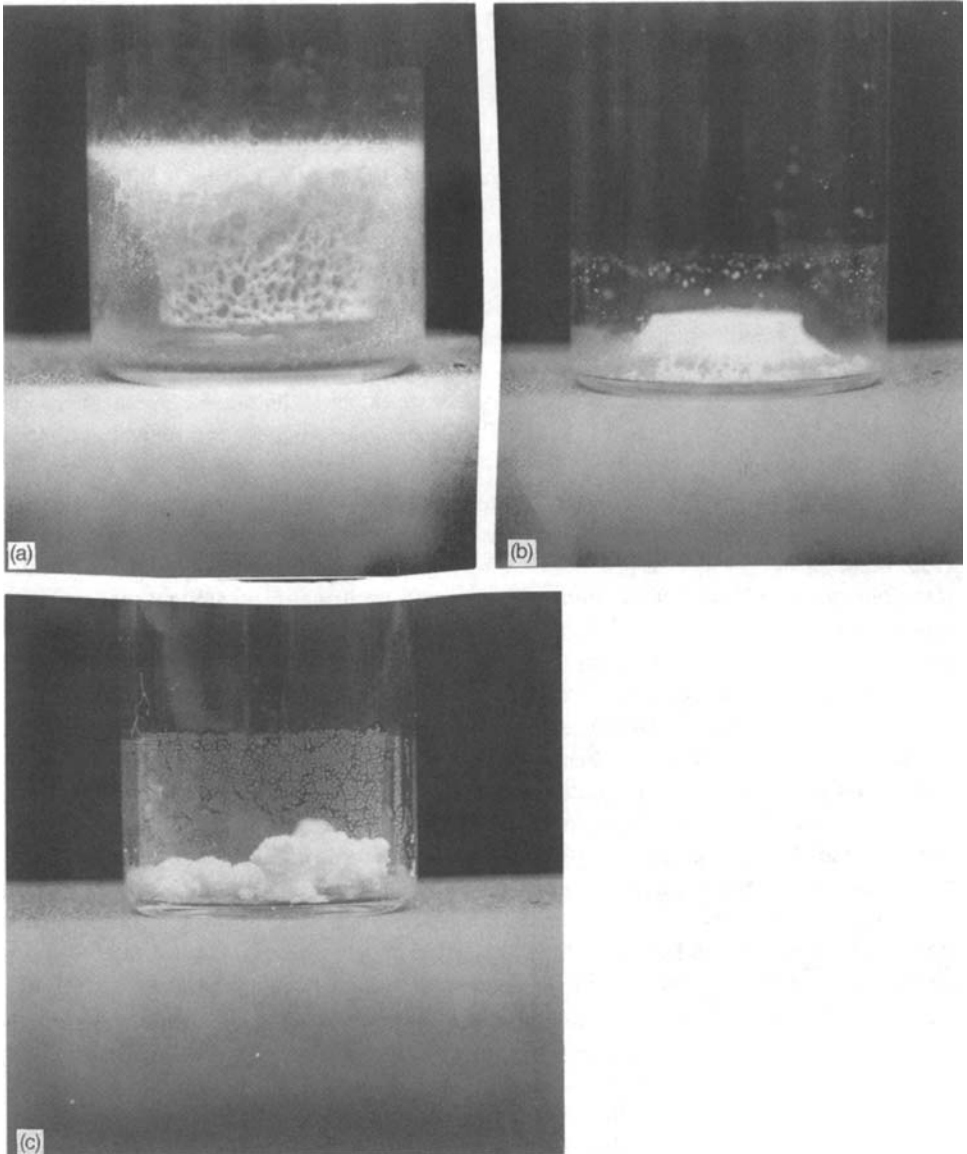


**Figure 3** The slight gap between the dried cake and the side wall of the vial exemplifies shrinkage that may occur with some formulations. This shrinkage may be attributed to either low concentrations or be characteristic of the materials in the formulation.

tion, resulting in a high residual moisture content. Reconstitution times may also be lengthened because of a “case hardening” of the dried material.

Because the objective of this process is the preservation of the lyophilized material, the presence of collapsed material is suspect. Collapse may simply be considered a cosmetic defect. When the collapsed material exhibits an increased reconstitution time or poor solubility, the presence of collapse becomes more than just a cosmetic defect. If, however, the collapsed material retains a higher amount of residual water, where this water becomes involved in degradation of the product through hydrolysis, then there is a more serious concern. The presence of a significant amount of residual water may promote degradation of the product, such that the assay falls outside of the compendial limits. There would also be a concern for the toxicity or an influence on the therapeutic effectiveness of the product. Both potential results should be considered during product development.

*Residual Moisture.* For virtually all materials lyophilized, the primary objective is removal of any water that would be chemically active during long-term storage of the product. Any readily available water may become involved in hydrolysis reactions, the common cause of degradation for lyophilized prod-



**Figure 4** Loss of the initial structure during drying due to the product being warmer than the phase transition temperature yields a varying amount of collapse. (a) A significant change in the cake shape and structure is illustrated. (b) Extensive collapse with minimal similarity of color and a dimensional proportion to the original cake. (c) Extensive collapse to form granular masses at the vial bottom with a residue on the side wall of the vial but without any recognizable similarity to the original cake.

ucts. Therefore, this requires that a sufficiently low residual moisture content be achieved. An acceptable level of moisture content, identified during development, is the primary indication that the lyophilization process was successfully completed.

The defined range suitable for acceptable stability may approach the variability of the moisture determination method or may be as great as a few percent. For example, many lyophilized products with the *USP* have a finished product residual moisture specification of less than 2% of dry weight. Other products, such as amphotericin B, have a residual moisture limit of 8.0% [31]. Whether the allowable residual moisture specification is small or large, a range of acceptable residual moisture needs to be identified and correlated to suitable long-term stability.

The analytical method for moisture determination must be validated before use during process validation studies. There are numerous techniques for moisture analysis that range from physical methods, such as loss on drying, to chemical methods, such as Karl Fisher titration. A comparative review of the conventional techniques are presented in an overview [32]. The measurement of residual moisture in lyophilized pharmaceuticals by near-infrared (NIR) spectroscopy has recently been expanded [33].

*Reconstitution.* Times required for reconstitution and the appearance of the constituted solution are also of importance. The nature of the dried material as a result of lyophilization often yields a product that is highly hygroscopic. Reconstitution is often instantaneous on addition of the diluent. For ease of use in a clinical setting, reconstitution times are often less than 2 min. Whatever time is required to resolubilize that material, the constituted solution should be clear and free of any visible particulates or insoluble materials, meeting the compendial requirements such as those outlined within the *USP* [31].

The method of reconstitution is also important. For example, the package insert for lyophilized somatropin indicates that during aspiration the diluent stream should be aimed against the side of the vial. In addition, the constituted solution should be gently swirled and not shaken [34]. Vigorous motion could result in aggregation of the protein to form insoluble particles. For amphotericin B, vigorous shaking is indicated until all of the crystalline material dissolves, forming a clear, yellow colloidal dispersion [34]. Whether the solution solubilizes instantaneously or requires special handling, forming a colorless solution or a colored colloidal dispersion, the expected appearance of the constituted solution needs to be a quality attribute established and supported by development data.

*Assay.* Analysis of the active ingredient, whether by chemical or biological methods, would be the same for the constituted product as that necessary for any ready-to-use preparation. Constituted solution, however, have a limited shelf life after addition to the diluent. Depending on the solution stability, the



package insert may indicate that the constituted solution be used immediately after reconstitution, or it may be stored at selected conditions, often 2–8°C, for a specified length of time. The stability of the constituted solution needs to be established during development and measured as part of the stability testing. The potency and purity must also be measured at the end of the indicated shelf life. This includes not only the solution after initial reconstitution, but also after storage at the conditions indicated for the constituted solution in the package insert. Analysis should also include assay of any degradation product.

## VIII. SUMMARY

Lyophilization is a complex unit operation, integrating multiple processing steps with varied conditions for completing the preservation of the drug material. This same process is applied to processing a relatively simple preparation for a drug substance and a compound formulation for a finished drug product.

Lyophilization processes consist of the manipulation of environmental conditions of subambient temperatures and subatmospheric pressures. These extraordinary conditions are created by the lyophilization equipment. The success of the process, therefore, relies heavily on the operating performance of the lyophilizer. Confidence in the ability of the equipment to create these necessary environmental conditions is achieved through the successful completion of a comprehensive IQ and OQ. Without the proper performance of the equipment, there is limited opportunity for successful processing of materials.

Throughout this presentation, emphasis is placed on the need to develop an appropriate and adequate process. This includes challenging the process to develop a proven acceptable range. The result of such an approach is a rugged and robust process, yielding cycle conditions that are safe, effective, and preferably, efficient. These processing conditions are demonstrated to be adequate and appropriate, ultimately through finished product testing. Of equal importance, this process is applied to preserve the quality of the material through processing and throughout the shelf life. Demonstrating the process suitability also requires correlating the process with product stability.

The behavior of the material during the processes is strongly dependent on the characteristics of the starting materials. Their characteristics must also then be measured and quantified. This includes not only the quality of the starting raw materials and excipients, but also in the preparation and packaging before placing the product into the lyophilizer.

Finally, how the characteristics and quality of the finished product are quantified is of equal importance. This includes the physical attributes of the dried material as well as the quality on reconstitution. The level of quality must

extend beyond the time of initial testing for release of the batch to the final expiration date.

When choosing constituents for lyophilization, select constituents based upon their interactions during freezing, the primary drying processing and possible reactions during secondary drying [35]. In addition, to remain properly lyophilized, the product must be sealed within its container prior to removal from the ultradry atmosphere that exists at the completion of the lyophilization cycle [36]. The freezing method used during lyophilization can substantially affect the structure of the ice formed, the water vapor flow during primary drying as well as the quality of the final dried product. Controlling how a solution freezes can shorten lyophilization cycles and produce more stable formulations [37]. Analytical tools for assessing the quality of freeze-dried pharmaceuticals have been developed separately by Daukas and Trappler [38] and Nail et al. [39]. Finally, improvements in the design and construction of production size freeze dryers, together with close attention to operating procedures have yielded dramatic improvements in achieving a sterility assurance level (SAL) of  $10^{-6}$  when clean-in-place (CIP) and steam-in-place (SIP) methods have been employed [40].

## REFERENCES

1. Chapman, K. The PAR approach to process validation. *Pharm Technol.* 4:47–54 (1984).
2. PDA. Validation of Computer-Related Systems, Technical Report No. 18. Bethesda, MD: Parenteral Drug Association (1995).
3. Dushman, S., Lafferty, J. M. *Scientific Foundations of Vacuum Technique*. New York: John Wiley & Sons (1962).
4. Ryans, H., Roper, D. L. *Process Vacuum System Design and Operation*. New York: McGraw-Hill, (1986).
5. Jennings, T. A. A model for the effect of real leaks on the transport of microorganisms into a vacuum freeze-dryer. *J Parenter Sci Technol* 44:22–25 (1990).
6. The Parenteral Society (PS). Technical Monograph No. 7, Leak Testing of Freeze Dryers. Wiltshire: PS (1995).
7. Greiff, D. Factors affecting the statistical parameters and patterns of distribution of residual moisture in arrays of samples following lyophilization. *J Parenter Sci Technol* 44:119–128 (1990).
8. Scheaffer, G., Sum, L., Trappler, E. Techniques in demonstrating batch uniformity for lyophilized products. Presented at the Annual Meeting of the PDA, Boston, Nov. (1995).
9. Day, L. Influence of vial construction and material on uniformity of product temperature during freezing and freeze drying of model product formulations. Presented at the Annual Meeting of the PDA, Boston (1995).

10. Pikal, M. J., Shah, S., Senior, D., Lang, J. E. Physical chemistry of freeze drying: measurement of sublimation rates by a microbalance technique. *J Pharm Sci* 72: 635–650 (1983).
11. Pikal, M. J., Roy, M. L., Shah, S. Mass and heat transfer in vial freeze-drying of pharmaceuticals: role of the vial. *J Pharm Sci* 77:1224–1237 (1984).
12. Trappler, E. Scale-up Strategy for a lyophilized process. American Pharmaceutical Review Fall 2001.
13. FDA. Proposed rules, Fed Regi, 61: 87 (1996).
14. Pikal, M. J., Lukes, A. L., Lang, L. E., Gains, K. Quantative crystallinity determinations for beta-lactam antibiotics by solution calorimetry: correlation with stability. *J Pharm Sci* 67:767 (1978).
15. Penner, G. Trappler, E. Effect of pH on the phase transition temperature of model excipients. Presented at the Annual Meeting of the PDA. Philadelphia, Nov. (1990).
16. Korey, D. J., Schwartz J. B. Effects of Excipients on the crystallization of pharmaceutical compounds during lyophilization. *J Parenter Sci Technol* 43:80–83 (1989).
17. Manning, M., Patel, K., Bochart, R. T. Stability of protein pharmaceuticals. *Pharm Res* 6:903–918 (1989).
18. Dubost, D., Kaufman, M., Zimmerman, J., Bogusky, M. J., Coddington, A. B., Pitzenberger, S. M. Characterization of a solid state reaction product from a lyophilized formulation of a cyclic heptapeptide. A novel example of an excipient induced oxidation. *Pharm Res* 13:1811–1814 (1996).
19. Orberholtzer, E. R., Brenner, G. S. Cefoxitin sodium; solution and solid-state chemical stability studies. *J Pharm Sci* 68:863–866 (1979).
20. Pikal, M. J., Dillerman, K. M., Roy, M. L., Riggins, R. M. The effects of formulation variables on the stability of freeze dried human growth hormone. *Pharm Res* 8:427–436 (1991).
21. Her, L., Deras, M., Nail, S. Electrolyte-induced changes in glass transition temperatures of freeze-concentrated solutes. *Pharm Res* 12:768–772 (1995).
22. Brittain, H. G., Bogdanowich, S. J., Bugay, D.E., DeVincentis, J., Lewen, G., Mewman, A. W. Physical characterization of pharmaceutical solids. *Pharm Res* 8: 963–973 (1991).
23. DeLuca, P.P., Boylan, J. C. Formulations of small volume parenterals. In: Avis, K. E., Lachman, L., Liberman, H. A. eds. *Pharmaceutical Dosage Forms: Parenteral Medications*, Vol. 1. New York: Marcel Dekker, 1984, p. 195.
24. Akers, M. J., Milton, N., Bryn, S. R., Nail, S. L. Glycine crystallization during freezing: the effects of salt form, pH, and ionic strength. *Pharm Res* 12:1457–1461 (1995).
25. MacKenzie, A. P. Non-equilibrium freezing behavior of aqueous systems. *Philos Trans R Soc Lond B* 278:167–189 (1997).
26. DeLuca, P. P., Lachman, L. Lyophilization of pharmaceuticals I, effect of certain physical-chemical properties. *J Pharm Sci* 54:617–624 (1965).
27. MacKenzie, A. P., Rasmussen, D. H. Interactions in the water-polyvinylpyrrolidone system at low temperatures, In: Jellinek, H. H. G. ed. *Water Structure at the Water-Polymer Interface*. New York: Plenum Publishing, 1972, pp. 146–172.
28. Diana Teng, C., Zarrintan, M. H., Groves, M. J. Water vapor adsorption and desorption isotherms of biologically active proteins. *Pharm Res* 8:191 (1992).

29. Bashir, J. A., Avis, K. E. Evaluation of excipients in freeze-dried products for injection. *Bull Parenter Drug Assoc.*
30. MacKenzie, A. P. Collapse during freeze drying—qualitative and quantitative aspects. In: Goldblith, W.A., Rey, L., Rothmayer, W. W. eds. *Freeze Drying and Advanced Food Technology*. New York: Academic Press, 1975, pp. 278–307.
31. USP 23 / NF 18, Rockville, MD: United States Pharmacopeial Convention, 1995.
32. May, J. C., Grimm, E., Wheeler, R. M., West, J. Determination of residual moisture in freeze-dried viral vaccines: Karl Fischer, gravimetric and thermogravimetric methodologies. *J Biol Stand* 10:249–259 (1982).
33. Root, D. E., Leasure, R. M. Measurement of Residual Water by Near-Infrared (NIR) Spectroscopic Analysis. PMPS Sept 2001.
34. Trissel, L. A., *Handbook of Injectable Drugs*. 8th ed. Amer. Soc. Hospital Pharm. 1994.
35. Jennings, T. A. Effect of Formulation on Lyophilization. IVD Technology Mar/Apr 1997.
36. Percy, T. E. Lyophilization Processing. IVD Technology May/June 2000.
37. Patapoff, T. W., Overcashier, D. E. Importance of freezing on lyophilization cycle development *Biopharm March* 2002.
38. Daukas, L. A., Trappler, E. H. Assessing the quality of lyophilized parenterals. *Pharm Cosmetic Quality Sept/Oct* 1998.
39. Nail, S. L., Schwegmani, J. J., Kamp, V. analytical tools for characterization of frozen systems in the development of freeze-dried pharmaceuticals. *Amer Pharm Rev Winter* 2000.
40. Stewart, P., Snowman, J. W. Recent advances in the cleaning and sterilization of industrial freeze dryers. *PMPS Dec* 2000.

# 10

## Validation of Inhalation Aerosols

**Christopher J. Sciarra and John J. Sciarra**

*Sciarra Laboratories Inc., Hicksville, New York, U.S.A.*

### I. INTRODUCTION

Inhalation aerosols have been used for the delivery of drugs to the respiratory system since the mid-1950s. The most common dosage form for inhalation is the metered-dose inhaler (MDI), by which the drug is delivered from a pressurized container using a liquefied gas propellant. Medication delivered via this dosage form has allowed for a quick therapeutic response to the symptoms of asthma, emphysema, and chronic obstructive pulmonary disease (COPD), and has resulted in an improvement in the quality of life for millions of asthma sufferers.

The metered-dose aerosol is considered to be a unique pharmaceutical dosage form since the drug is delivered directly to the lungs [1,2]. It should not be classified as either an oral dosage form, which generally is delivered through the gastrointestinal tract, or a parenteral dosage form, which is administered directly into body fluids or tissues. Metered-dose inhalers are classified as non-sterile products but should exhibit lower bioburdens than are found in oral or topical dosage forms. Since MDIs are nonaqueous systems they generally do not support microbiological growth. This system is pressurized using chlorofluorocarbons (CFCs) or hydrofluorocarbons (HFAs), thereby creating a self-propelling dosage form. As a result, different manufacturing and testing requirements are involved during the validation phase of new product introduction.

#### A. Types of Metered-Dose Aerosols

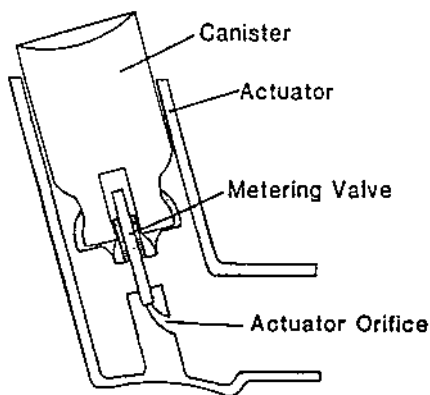
Nearly all MDI products are intended for delivery through the oral cavity [3]. There are a few products that are intended for administration via the nasal cavity, however. There is also a metered-dose aerosol for administration sublin-

gually. The site of administration will determine the type of actuator or adapter used in combination with the aerosol canister. Metered-dose inhalers are unique in that in addition to drug formulation, the entire packaging is critical for the correct administration of the medication. Figure 1 shows the basic components of an MDI system.

The medical use of metered-dose aerosols is usually for bronchial asthma or COPD. The drugs used represent different classes of therapeutic agents. Beta-adrenergic agents and the more selective beta2-adrenergic agents are the commonly used bronchodilators for the rapid relief of asthmatic symptoms. Corticosteroids help reduce edema and inflammation and are usually prophylactic in activity. Anticholinergic compounds and a mast cell inhibitor are also available in MDI form for the symptomatic treatment of asthma. Other therapeutic uses for MDIs include systemic activity, such as vasodilatation (nitroglycerin) and antimigraine (ergotamine).

There are two general types of formulations. First, the micronized active ingredient may be suspended in liquefied propellants (CFCs or HFAs). This group makes up the most common type of MDI. Second, the drug may be dissolved in a mixture of CFCs or HFAs and ethanol, forming a solution. Less than 25% of MDI products are formulated as solutions developed over 50 years ago.

Fewer than 12 different excipients in MDI products have been formulated into metered aerosols. The availability of established FDA-approved excipients limits the formulator to a select few such ingredients. [Table 1](#) lists excipients and the approximate amounts of some of these excipients that are currently used in MDIs. Metered-dose inhalers formulated with CFCs contain propellant 12, propellant 12/11, propellant 12/114, or propellant 12/114/11. These propellant



**Figure 1** Typical metered-dose aerosol delivery system.

**Table 1** MDI Inactive Ingredients

Type	Ingredient	Amount (%) <sup>a</sup>
Propellants	CFCs 11, 12, 114	60–99
	HFAs 134a, 227ea	
Dispersing agents	Sorbitan trioleate	0.01–0.8
	Sorbitan sesquioleate	0.01–0.8
	Oleic acid	0.01–0.8
	Soya lecithin	0.01–0.1
Cosolvent	Ethyl alcohol	2–38
	Water	5–10
Antioxidants and flavors	Ascorbic acid	0.1
	Saccharin	N/A
	Menthol	N/A
Antimicrobial	Cetylpyridinium chloride	N/A

<sup>a</sup>Approximate amounts derived from package inserts and literature; N/A = not available.

systems are required for proper dispensing of the MDI. Metered-dose inhalers formulated with HFAs contain either propellant 134a or 227 or mixtures of these two propellants.

## 1. Solution MDIs

Older drugs such as isoproterenol hydrochloride or epinephrine hydrochloride were formulated as aerosol solutions, with the drug solubilized in a chlorofluorocarbon–ethanol–water system. These aerosol solutions contain 30–38% (w/w) ethanol as a cosolvent and other additives to mask the poor aftertaste of the ethanol. Menthol, saccharin, and flavors are all currently used in some of these marketed products. Newer MDIs using HFA propellants are being formulated as ethanolic solutions. These MDIs contain 5–20% (w/w) ethanol as a cosolvent. These HFA-formulated solutions are unique in that the drug dissolved in the volume of ethanol is much more concentrated (10–50% w/w) than the CFC formulations containing ethanol, and a low concentrate (drug plus ethanol) is added to the container. Antioxidants such as ascorbic acid are also used to enhance the drug's stability in solution form.

## 2. Suspensions

The active ingredients in MDIs are usually water-soluble and chlorofluorocarbon- or hydrofluorocarbon-insoluble. Some CFC and HFA formulations use ethanol as a suspending agent by using an ethanol-insoluble salt form of the drug. Since the vehicle in MDIs must be propellant-based, a product with the drug suspended in the propellant may be the most stable dosage form.

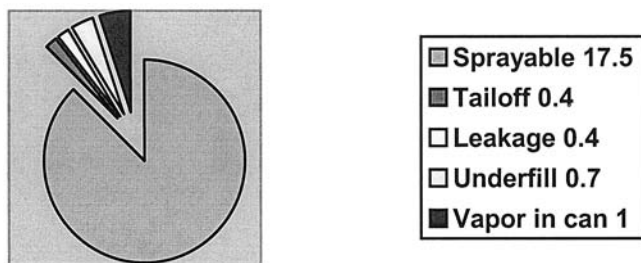
Nearly all suspension products contain a dispersing or suspending agent to facilitate wetting of the drug during manufacture of the suspension. All MDI suspensions with two exceptions contain sorbitan trioleate, oleic acid, or soya lecithin, all of which have surface-active properties. An MDI containing triamcinolone acetonide does not contain a typical dispersing agent but does contain a small amount of ethanol. These ingredients also have a lubricating action on valve components, although experimental studies have shown that they may be unnecessary for their proper functioning [4].

Suspensions contain micronized drug for proper delivery to and absorption in the respiratory system. Typical particle size of the micronized drug is from 2 to 5 microns [5]. Aerodynamic mean particle size as measured by cascade impactor or direct method of microscopic analysis is usually from 0.5 to 4 microns [5]. Additional particle-sizing techniques such as light scattering can be used [6].

The amount of drug in marketed products varies from 10 micrograms to 800 micrograms per actuation, as delivered from the actuator or mouthpiece. The amount of drug administered to the patient is small relative to that delivered in other dosage forms. Potent drugs are thus utilized and should have special care during raw material handling and manufacturing.

Most of the contents are delivered in the proper dosage in a filled aerosol canister. It is important to recognize, however, that some nonsprayable formulation remains in each filled unit. Each filled canister will deliver at least the labeled number of doses, and the actual can contains an overage to ensure delivery of the labeled number of doses. As an example, Figure 2 shows the approximate doses found in a 20-g filled unit.

In this example, if the average of the metered spray weighs 70 mg, then an average of 250 metered doses per canister will be obtained (sprayable 17.5 g). The nonsprayable contents (2.5 g) are derived from (1) propellant vapors in the can when empty of the liquefied portion, (2) allowance for filling variation leading to slight underfilling of contents during manufacture, (3) leakage of



**Figure 2** Approximate disposition of a 20-g filled unit.



propellant during the life of the unit, and (4) partial sprays (tail-off) due to incomplete filling of the valve chamber when the can is nearly empty. Any residual drug remaining in the unit is a negligible amount on a weight basis—less than 0.01 g—compared to the other items. The losses indicate why larger overages are used for this type of dosage form compared to an injectable drug.

## **B. Manufacturing**

Two methods for filling aerosol MDIs are used today—cold filling and pressure filling [5,7]. These methods describe the manner in which the propellant is added to the can or plastic-coated glass bottle. Solution or suspension formulations may be filled by either method.

In cold filling, the ingredients (including drug, suspending agents, excipients, and all propellants) are mixed and chilled to about  $-30$  to  $-60^{\circ}\text{F}$  prior to adding to the empty container. Filling occurs at temperatures well below the mixture's boiling point and before the valve is inserted onto the canister.

In pressure filling, only concentrate-containing drug, high boiling propellant, ethanol, and other excipients are filled before valve crimping. The low boiling propellant (CFC 12, HFA 134a, or HFA 227ea) is added after the valve is crimped onto the container. The propellant, usually at room temperature, is added through the valve stem under high pressure (300 to 600 pounds/square inch gauge [psig]).

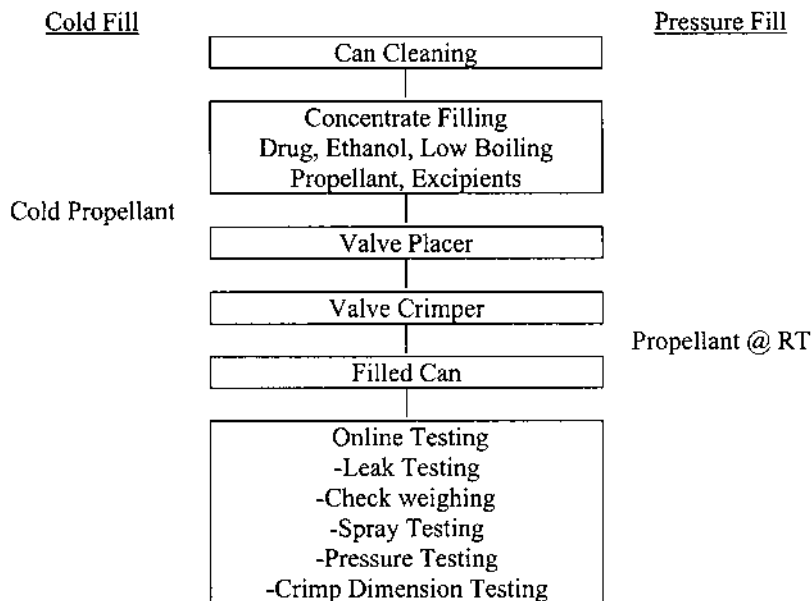
Typically CFC products utilize both the cold-fill and the pressure-fill processes. Whether a product is filled by pressure or cold, is determined by the manufacturing equipment available at a particular company and by the nature of the active drug. For example, since Albuterol is moisture-sensitive, it cannot be filled by the cold process. Hydrofluorocarbon products are typically filled using the pressure-filling method. [Figure 3](#) depicts the process flow, indicating both types of fillings.

Since metered-dose aerosols are not claimed to be sterile products, filling of the product does not require rated clean room standards as described in U.S. federal standard 209C. Frequently, however, high-efficiency particulate air (class 100,000) is employed above any open tanks and filling lines. This practice is used to reduce the likelihood of particulate and microbial contamination in the product.

## **II. RAW MATERIALS**

### **A. Ingredients**

In aerosol dosage forms, the micronized active ingredient, suspending agent, CFC, and HFA propellants are usually the most crucial raw materials. Other additives such as antioxidants or flavors may also be crucial.



**Figure 3** Types of aerosol filling.

### 1. The Active Pharmaceutical Ingredient

The important characteristics of the active pharmaceutical ingredient (API) are impurities, degradation products, water content (if hygroscopic), particle size [8], static charge, crystallinity, polymorphism, and microbial content. The milling or micronization process parameters should be recorded with micronized APIs. The finished product characteristics of the MDI may be related to the API (e.g., particle size). A reproducible drug particle size distribution [9], along with a validated manufacturing process, ensure lot-to-lot consistency of the final product. In addition, an acceptable water content of the drug substance prevents changes in agglomeration, crystallinity, or stability. Any additional tests performed on the active ingredient that are nonroutine release tests (e.g., X ray, diffraction, differential thermal analysis [DTA], or particle size) may be carried out for information purposes. Any specific test method used that was not part of the bulk drug testing specifications needs to be documented. For example, particle size or moisture content determined by a second method should be added to the validation report, along with the specific methods used. Reference samples of bulk drug should also be established. This may be of benefit in evaluating any future test methods.

## 2. Propellants

The propellants used in MDIs are trichloromonofluoromethane NF (CFC 11), dichlorodifluoromethane NF (CFC 12), dichlorotetrafluoroethane NF (CFC 114), tetrachloromonofluoroethane (HFA 134a), and heptafluoropentane (227). Currently marketed MDIs containing a CFC can continue to be marketed. The use of CFCs in new MDIs is prohibited except in certain essential uses in which an HFA propellant cannot be used. At a minimum they should meet compendial grade specifications. A single supplier should be preferred and used in the validation lots. Handling and storage techniques, such as temperatures, tank type, size, and headspace, should be noted for the propellants. Any blends of CFCs or HFAs used as a raw material for MDI manufacturing, whether purchased or prepared in-house, must meet assay specifications of each CFC or HFA. Specifications of a mixture such as water content or other compendial tests may also apply [10]. Assays and tests similar to compendial methods are needed until a satisfactory history of that supplier can be established. Table 2 lists key physical properties [11] of the five MDI propellants. The propellants used in MDIs are usually shipped in steel cylinders or drums and are under pressure. They may be stored outdoors before or during aerosol manufacture, provided temperature effects are controlled. It is industry practice to filter propellants before compounding or filling to ensure against particulates. The 0.22- or 0.45- $\mu\text{m}$  (nominal) "solvent-grade" Teflon, Nylon, mixed cellulose acetate, or polyvinylidene difluoride (PVDF) filters are reported to be compatible with CFCs and HFAs. These filters are used to remove particulates of micrometer or submicrometer size. Pharmaceutical sanitary housings and setups are preferred, and all contact parts such as O rings must be nonreactive to fluorocarbons. Cartridge-type filters are more common because of their ease of use and desirable flow rate. Fractionation of propellant mixtures inside a storage tank or cylinder must be monitored [12]. This occurs when the propellant with the higher vapor pres-

**Table 2** Key Physical Properties of Propellants for MDI Products

	Molecular weight	Boiling point (°C)	Vapor pressure (psig) at 21.1°C	Density (g/ml)
Trichloromonofluoromethane (P-11)	137.4	23.7	-1.3	1.485
Dichlorodifluoromethane (P-12)	120.9	-29.8	70.3	1.325
Dichlorotetrafluoroethane (P114)	170.9	3.6	12.9	1.468
Trifluoromonofluoroethane (P-134a)	102	-27	71.1	1.21
Heptafluoropropane (P-227)	170	-17	43	1.41

sure fractionates into the vapor headspace in a container, leaving a lower proportion in the liquid phase. When the liquid is pumped for filling it would then have an undesirable composition. Different pressures would result, and thus measuring container pressure may be a way to monitor fractionation within the propellant tank.

Sampling techniques for propellant mixtures should be performed rapidly to prevent vaporization of any of the propellants. Some techniques include; using prechilled cans, dipping with ladles, and crimping on the spot. Condensation of moisture onto the container and into the propellant must also be considered.

### 3. Suspending Agents

Suspending agents may have special requirements, such as specific storage and stability requirements. An example is soya lecithin, which is sensitive to light and air causing degradation into an odorous, discolored substance. Other natural products similarly need careful evaluation. Short-term expiry dates of 6 months may be best for unstable suspending agents. Special sampling programs for these materials might be extended to test for drum-to-drum variability within a lot of these types of raw materials. Sorbitan trioleate NF, oleic acid NF, and lecithin NF must meet their compendial requirements.

### 4. Cosolvents

The grade of alcohol used should meet the tests for alcohol USP. The amount of water may be critical, since MDIs are typically nonaqueous systems.

### 5. Miscellaneous

At a minimum, other inactive ingredients used in the product should meet compendial requirements. These include ascorbic acid USP, ether USP, menthol USP, saccharin NF or USP salts of saccharin, and flavors.

## **B. Package Components**

The packaging components of the multiple-dose MDIs are an integral part of the dosage form. Consistent delivery depends on the proper functioning of the valve throughout the use of the unit. The fit of the valve and actuator can also influence the drug delivery. If possible, obtaining the valve and actuator from the same vendor permits the vendor to test the combination in addition to the individual components, minimizing the chance for improper function of the combination of components.

## 1. Metered Valves

As with other packaging components, the incoming tests and specifications of metered valves, inspection attributes, and AQLs (acceptable quality levels) will need to be coordinated with the supplier. The valve should be considered as a critical package component and have incoming performance tests, such as spray weights and weight loss [13,14]. The performance test could be conducted on a sample of the valve lots from either scale-up or pilot trials before the validation lots are prepared. This information may also be available for each lot from the supplier. It is recommended that each test shown in Table 3 be conducted on at least three valve lots as part of the validation program.

The metered valves should be well characterized before beginning the process validation lots. The typical performance attributes, such as spray weight variations within and between valves of a single valve lot, spray weight variation between valve lots, leakage, crimp dimensions, and incoming inspection criteria, should be well known. In addition, the loss of prime [15] and single-shot assay data [6,16] should be generated during the development stage. Additional characterization of the valve done during development involves gasket extractables, compatibility with valve componentry [6], and particulate cleanliness.

The metered valve crimped on an aluminum can (anodized or plastic coated) glass bottle creates the uniqueness of the MDI dosage form. The dimensions of the valve parts related to the crimp, such as ferrule and gasket thickness

**Table 3** Important Valve Tests Per Lot

Test	Number of valves	Characteristics
Inspection for attributes	MIL-105E	Appearance, identity, proper assembly
Dimensional check	40	Proper components, identity
Valve delivery (spray weights), mean, RSD	40	Meter chamber size, in-use test, meter chamber variability
Valve delivery at labeled number of actuations <sup>a</sup>	6	Ruggedness of multiple sprays
Weight loss <sup>a</sup> (leakage)	12	Sealing capability, proper rubber sealability
Loss of prime <sup>a</sup>	12	Meter chamber sealability
Particulates <sup>a</sup>	12	Valve cleanliness
Extractables <sup>a</sup>	12	Rubber contaminants

<sup>a</sup>Tested for information; not part of routine testing of all valve lots.

may thus be critical in the finished package. Other critical dimensions are related to the metering chamber size for dosage reproducibility, stem dimensions for mouthpiece fitting, orifice sizes for meter chamber refilling and pressure filling rates, and stem stroke length or travel for spring resilience.

All valves contain rubber components (gaskets, tank seals, seats, or sleeves) and at least one stainless steel part (spring). Both are vital to valve functionality. Some types of valves contain more plastic or stainless steel components than others. Drawings of individual subcomponents of the valve should be on hand for reference to the incoming components. Periodic checking of the rubber or other components may be needed to ensure that the supplier has not changed any compositions or processing procedures.

The normal rejection rate during a 100% spray testing step such as percentage of no-sprays and continuous sprays would be helpful before validation. Should any deviations occur during the process validation lots, it is imperative to determine the cause of the deviation. If it involves leakage, spray weight, crimp appearance, or other attributes related to the valve, then the incoming component testing of the valve will be helpful. The component release test results should be reviewed and compared to the finished product testing. As stated, the incoming tests may be evaluated on pilot equipment or from scale-up lots using actual drug formulation. Alternatively, if it has been demonstrated that the drug has an insignificant effect (such as less than 0.2% drug of a suspension formulation) on valve performance for release testing, a placebo may be used to test incoming valves. Only after significant historical validation should the testing scheme in [Table 3](#) be reduced.

It is imperative to also consult the vendor to determine an adequate number of valves for spray weight testing. If the metered chamber is plastic, valves totaling at least twice the number of the vendor's mold impressions should be tested to guarantee complete evaluation of the lot of valves. The spray weight methodology conducted on valves can drastically influence the results. Because the valve is a mechanical device, the way in which it is actuated is technique-oriented. Manual actuation versus automatic actuation can cause variation in the results. Method ruggedness is essential in evaluation of the valve performance.

Leakage of the propellant through the valve is a critical parameter. Although the test is not required for metered valves in the USP, the leakage rate should be well characterized for leakage during development [6].

Valves may have special shipping or storage requirements. For example, some valves are shipped in hermetically sealed bags to prevent moisture adsorption to plastic or rubber parts. Others are shipped in plastic pails. Any expiration period of the valve must be known. Expiration periods result from the aging of the rubber componentry, which causes the rubber parts to lose their sealing or resilience, affecting spray weights and leakage.

## 2. Aluminum Can or Plastic-Coated Bottle

The drawing of the can or bottle should be on hand at the manufacturing site as part of the validation package. The drawings should specifically state the following:

1. Drawing number and date
2. Supplier code number or part number
3. Type of materials used (e.g., aluminum 5502, glass type)
4. Chemical treatments or coatings (e.g., glass treatment, aluminum anodizing, epoxy lining)
5. Container dimensions
  - a. Heights and widths, inside and out
  - b. Wall thickness
  - c. Neck and bottom curvatures and radials
6. Empty can or bottle weight
7. Special imprints or lettering (label copy, if preprinted can)
8. Any revisions to the drawings

The can may have had special cleaning procedures at the supplier's location prior to receiving. Testing of cans on incoming inspection usually involves identity, attributes, and dimensional checks. During development, any special coatings may require a chemical test such as pH or acid resistance. Key dimensions are usually related to the neck configuration, since slight changes may affect the integrity of the crimp and subsequent leakage.

## 3. Mouthpieces

Oral adapters, mouthpieces, or actuators are made of plastic polyethylene or polypropylene. As with the can requirements, drawings should be part of the validation package. Frequently this component is omitted from validation protocols of filled, crimped aerosol cans. This piece is critical to the functionality of the unit, however.

A validation program should be developed for the finished assembled package unit. All MDIs in the United States are packaged in one box with the can and mouthpiece preassembled and the canister placed inside the mouthpiece ready for use. A dust cap is provided to cover the end of the mouthpiece, which is in contact with the lips.

An incoming inspection and performance testing program should be in place for the mouthpiece. Some of the critical dimensions of the mouthpiece are the design configuration, valve stem and mouthpiece coupling, spray orifice size, and spray angle. The performance of a mouthpiece may be evaluated by measuring the spray pattern emitted from adapter. This is usually performed by

thin-layer chromatography [17] or video imagery [18,19]. The durability of the mouthpiece should also be checked as a kind of in-use test. Instructions to patients usually include washing the mouthpiece daily with water. This is to prevent buildup of residue near the orifice, which prevents adequate delivery of dosage or clogging. The type of buildup may be a unique characteristic of that particular product. The mating of the mouthpiece and valve stem is also important to the integrity of the package.

#### 4. Auxiliary Device

Auxiliary devices such as tube spacers are available for use by the patient. Some examples are Inspirease and Inhalaid devices [20]. Since they are provided separately from the MDI to the patient, they should not be considered part of the process validation. One such product however, triamcinolone Acetonide MDI, is fitted with its own spacer, and in this case the spacer is considered to be an integral part of the product.

### III. MANUFACTURING

#### A. Concentrate Preparation

##### 1. Suspensions

During a cold-filling operation, the suspending agent, micronized drug, and high boiling propellant (CFC 11 and/or 114) are mixed, forming a concentrated drug suspension. Mixing may be done by an impeller, turbine, or homogenizer-type mixer. The mixing conditions utilized throughout the process validation lots should thus be well documented. These include mixer details, position in the tank, speeds, direction, and recirculation conditions (if used). The mixers used should have qualification reports describing the design and performance details.

For compounding, jacketed stainless steel tanks capable of airtight sealing are frequently used. The temperature of the drug preparation should be monitored and sufficient to prevent evaporation of the propellant. Extremely low temperatures, especially in a room with high humidity, may lead to condensation of atmospheric moisture on recirculation lines, on filling equipment, or possibly within the tank. Some of this ice may chip off filling nozzles and fall into the canister. Nitrogen gas is thus usually used to blanket the head space before and during concentrate preparation. Gas flow rates, nozzle positions, and other conditions in the tank should be recorded. Temperatures above 55–60°F may be too high if the drug concentrate requires greater than 1 hr preparation time. In these cases temperature fluctuations could lead to evaporation of the high boiling propellant (which boils at 75°F). This evaporation will increase the drug concentration, resulting in a change in drug dispensed/actuation.



Mixing tanks are preferably set on load cells or scales to ensure accurate weighing of the volatile propellants and drug concentrates. Any evaporation or loss of propellant can thus be monitored. Without a means of obtaining the gross tank weight for the concentrate, accurate in-process assays will be required to verify any loss of propellant. In suspensions, some drugs are easily dispersed, whereas others require extensive mixing. If a homogenizer or colloid mill is used, these conditions will also require documentation. The drug concentrate may be filtered through an appropriate sized filter in order to assure an aggregate-free suspension. This may not be needed if validation testing shows no aggregate particles be present.

## 2. Solutions

Since solution aerosols contain ethanol as a cosolvent in order to render the drug soluble, the ethanol and propellants are mixed and drug is added. The concentrate solution may also include high boiling propellants [21]. Temperatures must be low enough to assure minimal evaporation rates during filling but also enable suitable dissolution of ingredients. Temperatures from  $-50$  to  $+5^{\circ}\text{C}$  have been used [21]. The propellant blend must provide sufficient vapor pressure to propel the contents for inhalation, usually 35 to 60 psig (at  $21^{\circ}\text{C}$ ). Higher pressures are also used (CFC 12, HFA 227, or HFA 134a alone, 60 to 70 psig at  $20^{\circ}\text{C}$ ).

## 3. Types of Filling Equipment

In filling MDI concentrates, usually amounts of about 1 ml to 15 ml are added to the canister. The filling equipment consists of either gravity filling with timed microswitches or positive piston fillers. Piston fillers are used on such units as Pamasol filling equipment. Product added by gravity filling may be controlled by nozzle size and time. Gravity filling is usually best for volumes of 2 ml or greater. Piston filling is controlled by piston size, bore size, and length. This method is usually very accurate and precise. It may be necessary to shroud the filling area with nitrogen to prevent moisture condensation on the filling equipment and nozzles. Equipment may be fabricated to prevent outside atmospheric moisture from entering. Nitrogen flow rates should be monitored as part of the process validation protocol.

### B. Propellant Filling

#### 1. Cold-Fill Method

The propellant in cold-fill products almost always is a mixture of CFC 114 and 12 with or without propellant 11. Chlorofluorocarbon 114 reduces the vapor pressure of 12, enabling it to be cold filled at higher temperatures without the

loss of propellant. Mixtures of CFCs 114 and 12 may be added to the drug concentrate containing CFC 11 and then filled into the can or bottle, or may be cold filled separately after the drug concentrate is added. Propellant 134a or propellant 227 may also be filled by the cold-fill method.

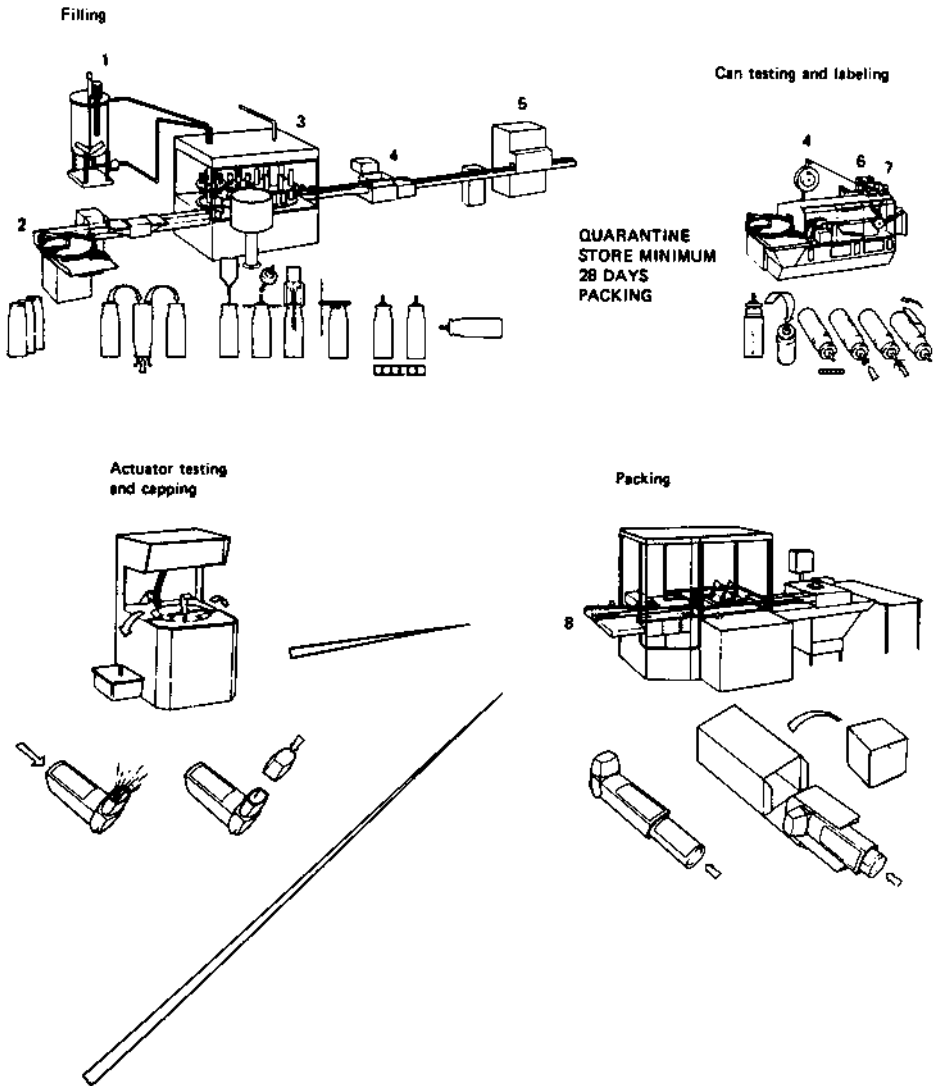
## 2. Pressure Fill

During pressure filling, the propellant or propellant blend may be pressure filled alone or in combination. Pressure filling requires two filling steps, drug concentrate and propellant filling. [Figure 4](#) shows a schematic sequence of MDI manufacture [22]. Tolerances must be established for each filling stage—control limits for adjustment and tolerance limits for acceptance or rejection. In-process check weights are usually performed at specified time intervals during validation to verify the accuracy of filling. Control charts are then assembled for each filling operation of each validation batch. Upper and lower limits are usually clearly marked for simplicity. For a two-step filling operation with drug concentrate followed by propellant filling, the acceptable drug concentration in the can may be used to calculate acceptable filling amounts. For example, a lower limit of drug concentrate fill and an upper limit of propellant fill will provide the lowest possible final drug concentration. The specifications can be determined for the suspension of the filled can to be within 90 to 110% of the label claim. In this example, a concentrate fill of 1% drug (50 mg/5.00 g) provides a final can potency of 2.50 mg/g. It is important that the specifications, equipment, and fill quantities be coordinated so that limits are attainable. The original fill amounts and ratios of propellants should be formulated in such a way that ranges of acceptable concentrate and propellant are adequate.

Since more than 99.99% of filled cans would be within four standard deviation units of a normal distribution, four standard deviation units appear to be an acceptable target for fill-weight variations. The concentrate filler should exhibit a relative standard deviation of less than 2.0%, one-fourth of the 8.0% upper and lower limits of the concentrate fill. [Figure 8](#) depicts an example of concentrate fill target of 3.89 g and specification of  $\pm 0.23$  g (5.9%). The propellant fill should have a relative standard deviation (RSD) of less than 1.5%, one-fourth of the 5.9% limit. Tightening either the propellant or concentrate filler will allow loosening of the second fill limits while maintaining the same specifications of the final product.

## 3. HFA Filling (Single-Stage Filling)

With the introduction of HFA propellants as replacements for CFCs in MDIs, both the cold-fill and pressure-fill processes have been modified. Both solution and suspension formulations have been developed. Solution MDIs are filled, as has been previously indicated. For suspensions (and solutions as well), however,



**Figure 4** Schematic production sequence for the manufacture of metered-dose inhalers by pressure filling: (1) suspension mixing vessel; (2) can cleaner; (3) can crimper and filler; (4) check weigher; (5) can coder and heat tester; (6) priming and spray testing; (7) labeler; (8) feeds for tested cans and actuators. (Courtesy of Ellis Horwood Publishers, Ref. 10.)

the formulation (drug with or without any excipients, dispensing agent, etc.) is added to a pressure tank capable of withstanding at least 150 psig at room temperature. The tank is sealed and the entire amount of propellant (CFC or HFA) is added under pressure. The entire mixture is then agitated until the drug is completely dissolved or suspended in the propellant. This mixture is then fed to a filler where a canister (previously cleaned, purged, and crimped with a metered valve) is filled through the valve stem with the propellant. This is referred to as single-stage filling. The equipment is made to flush any drug or propellant remaining in the valve stem into the canister. Each stage of the process must be validated to ensure that the finished product meets all specifications.

### C. Crimping

The crimping station on an aerosol line occurs after the valve has been placed on the canister. The valve may have been placed either manually or with automatic equipment. Crimping should occur as soon as practical after filling and valve insertion to minimize air entrapment and propellant vaporization. During crimping, the ferrule of the valve is compressed by closing the jaws on the collet, crimping the valve under the neck of the can or bottle. Crimping parameters and measurements are recorded during process validation to verify the suitability of the crimping process [23]. An adequate crimp is needed for acceptable leakage, appearance, valve function, and propellant filling. Crimping parameters are usually

Head pressure (downward pressure exerted on the top of the valve)

Collet pressure (of closing collet)

Pad pressure (if this type of equipment is used)

If the crimp settings are stressed to extremes during development, corresponding acceptable limits may be established. For example, the collet pressure would be increased in stages to a point of unacceptable appearance or leakage. The height or diameter of the crimp would also be determined for the different settings. Before limits are finalized, several lots of valves and cans will have to be measured, since these components have an effect on the final crimp measurement. Critical crimp measurements taken on the crimped valve are described below.

#### 1. Height or Depth of Crimp

The height of a crimp is measured from the top of the crimp jaw marks to the top of the ferrule. The height of the crimp should be correlatable to the leakage. When the height is too large, the valve has been improperly seated and leakage may be excessive. If the height is too small, excessive pressure may have been applied during crimping, affecting the valve function or appearance. Usually, crimp height values are 6.5 to 7.5 mm (0.26 to 0.30 in.). The tool for measure-

ment is calipers or another specialized device, such as a Socoge gauge for measuring the depth of a crimped valve at a constant 19-mm radius.

## 2. Diameter or Radius of Crimp

This measurement is taken from one point on the crimp circumference to the other point at 360°. The diameter is correlated to the pressure applied on the jaws during closing of the collet. The usual values are 17.5 to 18.5 mm for a valve and can with 20-mm uncrimped diameters.

## 3. Roll Off

Measurements taken of the top of the ferrule to the bottom of the can at four locations 90° apart indicate the uniformity of pressure applied to the valve during crimping. The difference between the highest and lowest of the four values is called roll off (or run out). The results should be small (typically less than 0.1 mm).

## 4. Gasket Compression

This indicates the percentage of compression of a sealing gasket on the crimped unit. The rubber gasket is compressed a certain percentage, enabling a seal to occur between the ferrule of the valve and the can. It is determined by subtracting uncrimped gasket thickness from the crimped unit thickness. The crimped unit gasket thickness is measured by subtracting parts from the crimp height after disassembly of the filled unit.

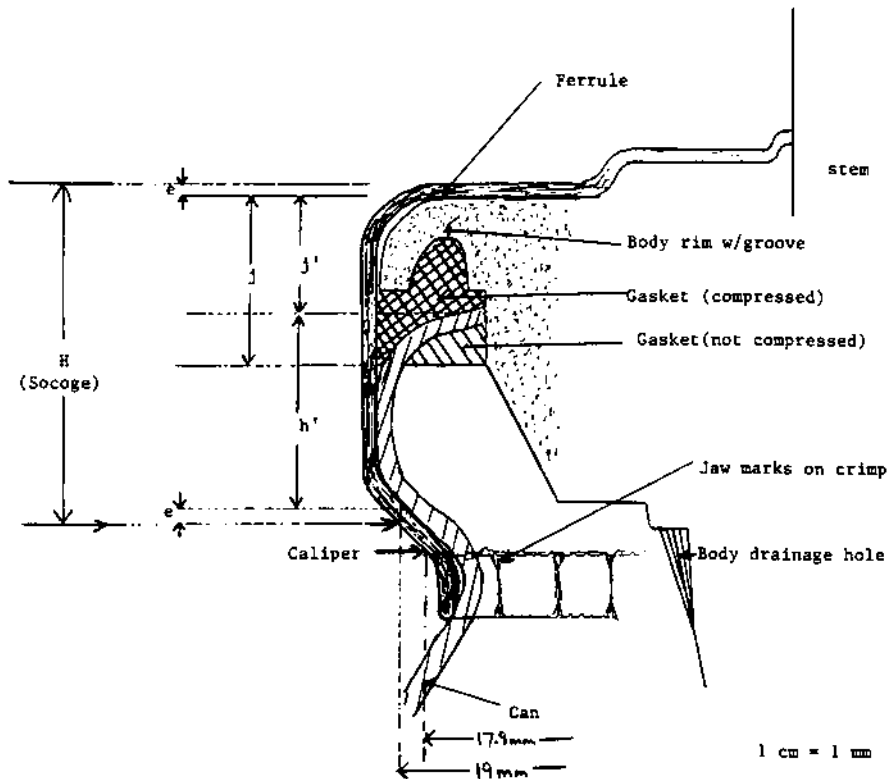
$$j' = H - (2 \times e) - h' \quad (1)$$

Here  $H$ ,  $h'$ , and  $e$  are measured dimensions of the valve as defined in [Figure 5](#). For example, a crimped unit of height  $H$  of 7.00 mm, ferrule thickness  $e$  of 0.36 mm, and can neck height  $h'$  of 3.85 mm yields a crimped gasket and rim thickness  $j'$  of 2.43 mm. If the before-crimp gasket and rim thickness  $j$  is 3.04 mm and only the gasket of thickness 1.26 mm has compression, the compression is 48%. In other words, the gasket has compressed 0.61 mm (3.04 to 2.43 mm) of 1.26 mm.

For valves with O rings the gasket compression is more difficult to measure. Gasket compression has also been correlated to leakage, where a decrease in the leak rate occurs with increase in gasket compression.

## 5. Can Deflection

The aluminum cans are deflected a small distance from their original height during crimping when a high pressure is exerted downward. Deflection is measured by carefully removing the valve of a crimped unit with pliers and measur-



**Figure 5** Gasket compression and crimp depth measurements (Socoge gauge).

ing the height of the deflected can compared to an uncrimped can. A Socoge gauge may also be used to measure deflections at a constant 19-mm diameter ( $h'$  in Fig. 5).

## 6. Appearance

The crimp should be aesthetically pleasing and free from exposed or sharp edges at the end of the valve. It should tightly fit the contours of the can.

### D. Leak Testing

All filled aerosol cans are leak tested before distribution to prevent an empty or near-empty product from reaching the patient. Four methods are currently used for leak testing.

1. Hot water baths are maintained at temperatures above the boiling point of the product, such as 100°F. More common temperatures are 120–130°F, since the time to raise the can contents would be shorter. At least 1.5 to 3 minutes are required to bring the can contents to a temperature that would emit propellant vapor in a leaky unit. Cans are examined visually by inspectors who look for the presence of faulty crimps, valves, and so on. The emergence of bubbles signifies a probable reject. Protection from possible dangerous discharges should be taken. Filtered tap water has been used to test for leakage because the water does not come into contact with drug product. Currently companies are trying to use recirculated and filtered purified water in combination with ultraviolet lamps to minimize the microbial bioburden in the water. Various types of defects usually arise from poorly crimped valves (process defect), where bubbles appear from the side of a valve skirt or ferrule. Other rejects may be due to poorly assembled valves (valve defect), where leakage from the side of stem may occur.
2. Induction heaters, in which cans are quickly heated and check weighed at a later time [24], heat the units instantaneously on the aerosol line after filling and crimping. Any faulty units or poor crimps would burst upon testing and be removed from the line. Subsequent check weighing is usually performed and any intact units that are leakers are removed. Induction heaters were introduced as an improvement over the visual inspection method. Storage of the filled units for a set period of time has become the most commonly used method for leak testing. Units are held for a sufficient period of time so that leakers will fail a subsequent check weighing step. Fourteen to 28 days have been used to ferret out faulty units [22]. Inventory considerations have to be taken into account with this process requirement. Also, the probability that slow or latent leakers will pass undetected must be considered.
3. Storage for a predetermined time period before check weighing.
4. Pressure readings are designed to check the integrity of componentry before filling. This was designed to check the tightness of the crimp, which could be used later for performance evaluation.

## **E. Check Weighing**

This step is commonly carried out to ensure that all cans reaching the consumer contain an adequate supply of medication [25]. This may be conducted on units after filling or leak testing but must be done before secondary packaging and distribution. In setting the limits of the check weigher, the allowable fill weight

variation and component weights must be factored in. The check weigher must have low tolerances (usually less than 100 mg), well within the ranges of the filled aerosol unit. Units filled with a known weight of steel beads may be used to set the upper and lower limits. The rate of the check weighing step and the set limits, along with the number of high and low rejects, should be tallied during validation. Random units (failed and good product) may also be individually weighed to verify the accuracy of the check weigher. Histograms may be generated over a period of months for characterizing the expected leakage during development. These are then compared to histograms of the same cans that were generated immediately after manufacture.

## **F. Spray Testing**

This step is performed on all filled units to remove any defectively spraying MDIs such as no-sprays or continuous spray units. Two general methods are used today, an automatic method and a manual method. The automatic unit may employ different techniques, such as light or sound. For example, the sounds of acceptable and unacceptable actuations are programmed and used for testing. Continuous or no-spray valves will sound different from a single-fire acceptable valve.

The presence of a powder as an aerosolized mist may be used so that testing will be by an electronic eye. Manual methods include listening devices for sound inspection or sprays for visual inspection of sprays. Hoods or spray booths are used online where inspectors manually actuate units and observe for defective sprays. Manual actuation for sound may be performed into vacuum setups with microphones that amplify the valve actuation noise. The usual number of actuations for testing is between three and five. At least two are considered as priming shots, followed by a test fire. Rejection rates vary from lot to lot and supplier to supplier but are usually less than 0.1%. The rejection rate, classified by defect, and the testing method should be documented for the validation lots. Rejected units should be closely examined for any false results and may be used to improve the valve manufacturer's quality control.

## **IV. VALIDATION PROTOCOL**

### **A. Development Report**

A development report should be written prior to the process validation protocol by the research and development group and will serve as the basis for items to be included in the validation protocol. Parameters such as process limits, formulation compatibility with process equipment, time limitations of production, and any problems encountered and their resolution, should be addressed. Aerosol



product characteristics such as microbial challenge data, through-life testing of units [26], resuspendability [27,28], first-shot assays, and typical loss of prime should also be well known. The effect of spray assay methodology on the product results is beneficial information. The product also should be fingerprinted for three-dimensional plume patterns and particle size distribution by two or more methods. One of the methods should evaluate the aerodynamic particle size. A development history that describes chronological events during formulation is also beneficial and frequently will help the specialist preparing the protocol. Reference to the development report(s) may be included in the protocol document.

## **B. Preparation and Execution**

The process validation protocol of a new aerosol product should be written by a qualified manufacturing or validation specialist familiar with aerosols. Others experienced in oral dosage forms such as suspensions or solutions would also be helpful. These technical specialists may be within the research, validation, or technical support departments, since this work will be done prior to approval of a new product. Approval of the protocol should be given by quality assurance, quality control, production management, and research.

Other experts will be involved in aerosols. A packaging specialist will also play a critical role, since the functionality of the dosage form depends on the package performance (i.e., valve and mouthpiece). Secondary packaging, in which the filled unit may be check weighed, spray tested, and assembled with the mouthpiece into a boxed unit, will need qualification and validation. In the case of third-party or contract manufacturing, production and quality control management at the manufacturing site should review the validation protocol and report. In some instances, the third party may prepare a protocol; however, the final responsibility for validation approval lies with the new drug application (NDA) or abbreviated new drug application (ANDA) holder and marketer of the aerosol.

The validation protocol should be prepared after the master batch record is approved and signed by responsible parties (i.e., the manufacturer and NDA or ANDA holder). The batch directions should be detailed and easily understood. For example, mixing speeds and times, mixer positions, and method of adding ingredients should be explained clearly. The protocol must agree in process descriptions and flowcharts and be specific enough to remove any ambiguities on process conditions, decisions, or product specifications. For these reasons, it is usually beneficial to prepare a production-sized, prevalidation batch with the proposed final batch record. This batch should also be completely tested and meet finished product specifications.

The manufacturing or validation specialist should execute the protocol; that is, that person should carry out and coordinate any process monitoring,

aerosol line conditions, sample collection, and physical testing. The quality control unit that will routinely analyze the product after routine production starts should test the validation batches. This unit would also be responsible for stability tests conducted on the validation batches.

### **C. Final Process and Product**

The process must be validated at the manufacturing site(s) specified in the regulatory filing (NDA or ANDA). The aerosol product must be prepared with the manufacturing equipment and process intended for the routine production. It is enticing the make the batch record changes during or after validation batches have begun as a means of improvement. Changes in any manner, such as order of addition of raw materials, method of weighing, screening of any raw materials, aerosol line functional changes, mixing conditions, or mixing equipment, should be considered as major changes and be documented accordingly. Revalidation would be required for any changes made.

The batch record must be diligently followed during validation. Process or formulation variations (quantitative or qualitative) are not permitted. A change in any process step or steps will require restarting or amending the validation program. Examples would be adding a dilution step for dissolving or dispersing ingredients or changing homogenization times of wetting a suspension.

Because of time constraints it might also be tempting to begin validation before the final setup is in place. An example might be to use a temporary filter setup, tank cover, agitator propeller, or other piece of equipment. A short-term delay in the start of validation batches would be preferred until the equipment and laboratory readiness is complete. Testing must include validated analytical procedures using the mouthpiece intended for the marketed package.

### **D. Worst-Case Conditions**

Meaningful process limits on conditions will need to be established if not done previously during development. Operating outside the set limits may or may not lead to failure of the process or product specifications [29]. Limits may also be used to demonstrate that process conditions are under consistent control. Examples may be the humidity range (e.g., 30–45%) in the manufacturing room, mixer speed ranges (45 to 55 rpm), mixer position (angle or distances), nitrogen flow to a tank (2 to 4 standard cubic feet/hour [scfh]), or suspension temperature range (20–30°F).

Evaluating worst-case conditions will justify many of these process limits. A “subprotocol” for testing the worst-case scenario should be clearly specified in the validation protocol. An alternative and preferable procedure would be to test these conditions during development. For example, drug uniformity might

be verified by using the lowest mixer speed (45 rpm), lowest temperature (20°F), and highest nitrogen flow rate (4 scfh). Lack of volatility may be confirmed by testing the highest nitrogen flow (4 scfh) at a high mixing speed (55 rpm). Rates of addition of raw materials (1 to 5 min) may also need evaluation. These tests may be conducted during the prevalidation batch in order not to interfere with a supposed production (validation) batch.

## **E. Timing**

The protocol must be approved and signed before the first production batches are started. Since aerosol manufacturing involves more package components (valves, cans, mouthpieces) than other dosage forms, receipt and release testing of these components must be incorporated in the planning schedule. Also, since aerosol products involve more lengthy finished-product tests than other dosage forms, release testing usually requires more analytical laboratory time.

## **F. Testing and Specifications**

Due to extensive testing for aerosol products, the sampling and testing scheme must be carefully reviewed before starting validation. Most MDI aerosols are suspensions involving volatile propellants that are mixed and filled over long periods (greater than 6 hr). Many drug uniformity samples may thus be required to demonstrate reproducibility and show that volatility or loss of propellants and drug is under control. Some aerosol tests that frequently should be monitored are filled-unit yields, leakage rates, valve-spray reject rates, moisture values, assays, and valve rubber leachables. Alert limits for critical tests are suggested to avoid uncertainty over pass/fail situations and act as a guide when there is a cause of concern. Tentative limits could be used until a history of production batches is obtained. Examples may be a content uniformity RSD of 5.0% versus specification of 6.0%. Developmental data on the pilot-scale batches will assist in setting initial alert limits. These alert limits do not substitute for the actual limits but merely serve as a guide for investigation.

## **G. Stability**

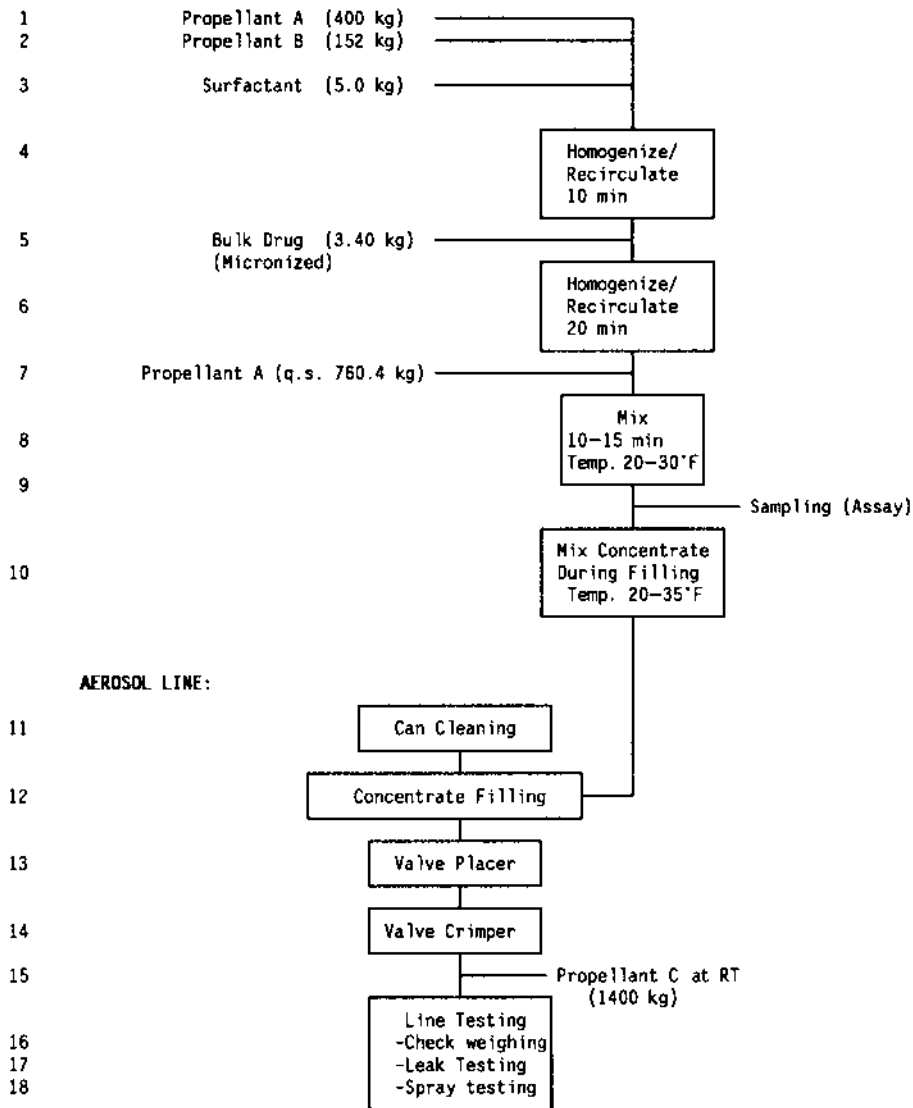
Stability testing of the validation batches should be conducted at the quality control laboratory. At a minimum it should be conducted at labeled storage conditions. Accelerated conditions are not usually required because this is supplemental stability, not primary.

## H. Protocol Format

1. *The objective* briefly describes the purpose of the validation program. An additional objective is to provide supplemental manufacturing information beyond that recorded in the batch documents.
2. *The scope* section describes what the process validation protocol covers, the number of batches, and what it does not cover. In this part, usually packaging validation or mouthpiece testing is included or excluded. Any worst-case tests may be briefly described. Stability commitments and stability protocols should be mentioned.
3. *Formulation and components*. The specific quantitative formulation and components should be listed, along with identification or company code numbers. The amounts per can, per batch, and percentages should be listed here. Additional formulation information also may be enumerated; including the following:
  - a. Amounts per actuation: drug formulated ( $\mu\text{g}$  drug and mg total), drug delivered from mouthpiece, and drug retained on mouthpiece.
  - b. Amounts per can: sprayable contents (number of labeled sprays  $\times$  mg/spray), nonsprayable contents (tail-off sprays, vapor retained, drug retained), leakage over expiration period, spray-testing loss, fill-weight allowance (underfill tolerance), material balance.
4. *Process flowcharts*. A flow diagram should indicate the process steps and addition of raw materials. If possible, major equipment and special environmental conditions may be included in the flowchart. In-process tests may also be included. A second flowchart for activities, raw material suppliers, shipments, and testing would also assist in the overall picture of the aerosol manufacturing scheme, especially for multiple site or third-party activities. An example of a process flowchart for a fictitious suspension product (2160.4-kg batch size for 100,000 units) is shown in [Figure 6](#).
5. *Document checklist*. All documents that should be examined and in proper order prior to the initiation of the validation batches are listed. They are checked for availability and accuracy. Preparation of batches should not commence unless these documents are finalized and signed. An example is shown below:
  - a. New drug application (applicable sections, NDA or ANDA)
  - b. Calibrations: scales and balances, temperature-measuring devices, tachometers, environmental conditions measurements (room temperature, humidity, pressure; HEPA filter certification), pressure gauge.
  - c. Standard operating procedures: physical tests (pressure testing,

**CONCENTRATE PREPARATION:**

STEP



**Figure 6** Process flowchart.

- spray dosage, number of sprays, moisture in unit, weight loss, testing of valves, cans, actuators, overcaps), chemical tests [in-process assay, identification test, drug assay (mg per can), drug valve testing].
- d. Product specification sheet (line check form, bill of materials).
  - e. Training documentation.
  - f. Cleaning procedures (cleaning procedures, cleaning validation report).
  - g. Certificates of analysis of components (for each validation batch): each raw material (active, flavors, cosolvents, surfactants, antioxidants, antimicrobials), propellants (CFCs), nitrogen or other inert gases, metered valves, canisters, overcaps, mouthpieces.
  - h. Master batch record documents: batch card, chemical weighing records, yield reconciliations sheets, in-process data sheets, production area readiness checklist, computer system documentation, mechanical line setup sheets.
  - i. Qualification reports and equipment manuals: tank or vessels, mixers [homogenizer (colloid mills), tank agitator, mixers], concentrate filler, recirculation pumps, crimper, pressure filler, checkweigher, spray-testing unit, environmental control areas (temperature and humidity).
  - j. Development report (research report number).
  - k. Safety documents (material safety data sheets).
  - l. Validation protocol (current document).
6. *Process monitoring.* This section depicts the intended process conditions and parameters that will be measured. Items that are not recorded in the batch record but that may be critical should be tabulated here, along with target or expected values. The frequency of the measurement (e.g., once), the method (e.g., timer), and where it will be recorded (e.g., form A) should be tabulated. Many of these items will depend on past experience during development. An example may be the rate of addition and location of the micronized active ingredient or observations of the aerosol solution or suspension appearance. In short, if a quantitative measure of a given step is obtainable, this number should be recorded. A thorough and detailed master batch record will minimize the additional monitoring required for validation. Filling line items on a line setup sheet will also need monitoring. Items not recorded in batch documentation should be tabulated or listed in the protocol as intended for monitoring during validation. Examples might be crimping collect numbers, line speeds, or propellant injection pressures during the filling process.
7. *Sampling and testing.* This section provide specifics on the sam-

pling, testing, and acceptance criteria intended during the validation batches. Methods of sampling concentrate or removing filled cans from the line should be clearly described. Lists of in-process tests, where sampled, number of cans, and responsibility should be tabulated. A separate table may be needed to describe the test, method, frequency, specifications, and comments. All in-process samples must pass specifications in order to claim a validated process. Statistical testing at the beginning, middle, and end of the process usually can demonstrate the consistency of manufacturing. Similarly, tables of finished product tests showing expanded testing regimens (e.g., beginning, middle, end, and composite), methods, and specifications will be needed.

8. *Responsibility and timing.* This section will provide a guide for specific goals of each group. The target timing requirements (e.g., 6 weeks to place on stability) will show the responsibility of each person(s) from protocol writing to report approval.
9. *Appendix.* Forms with blanks may be provided in the protocol to be filled out during each validation batch. These forms are for process monitoring of compounding, line functions, in-process sampling, and so on. They should include such specifics as types of measuring devices (serial numbers) and include sign-offs for “done by” and “checked by” signatures. A clearer indication of the process requirements results from preparing and reviewing these forms.

## V. ADDITIONAL VALIDATION PROTOCOL ITEMS

Additional items that were not detailed in the aforementioned protocol description may be monitored during validation.

### A. Materials Monitoring

Metered valves are critical to the functionality of this dosage form, and a thorough understanding of this component is essential. [Table 3](#) shows some tests conducted on metered valves. Footnoted items are special tests performed for valve characterization, not necessarily for individual lot release.

Storage and handling of the propellants (CFCs and HFAs), types of filters, transfer piping, and storage tanks should be standardized. Any observations of the appearance of the propellants should be recorded. The supplier’s specifications should be reviewed.

Other ingredients and packaging components might require special environmental storage conditions. Room temperature and humidity should be docu-

mented during facilities qualification prior to process validation (e.g., bulk drug, surfactants, cosolvents, and flavors).

Containers for storing the raw materials should be specified in the material specifications sheets or packaging bill of materials. Although outside the scope of validation, the manufacturing specialist should be aware of such issues.

Weighing of ingredients by the weighing or chemical dispensing department should include the gross, tare, and net of each ingredient. Future abnormalities of yielding or potency may be found by having unusual tares or discrepancies arising from the weighing of components. Unusual tares such as for jacketed tanks should include specifics (coolant, lid, etc.) and the method of taring.

## **B. Process Monitoring**

### **1. Preparation of Suspension or Solution**

Validation should confirm the order of addition of raw materials, rate of addition, method of addition, and mixing conditions during compounding of the aerosol suspension or solution. The specific type(s) of mixer(s), blade(s), speed(s) and position (pitch), or placement in the vessel should be specified in the batch directions. The batch temperature and room conditions (temperature, humidity) should be fully documented if not recorded in the batch directions.

*Air Cleanliness.* Air cleanliness may be an important factor, especially if the compounding is done in open vessels exposed to the ambient air. Air cleanliness (type of air) by recording high-efficiency particulate air (HEPA) filter types, airborne particulate counts, and any microbial monitoring such as sampling and incubating with media may be part of the environmental testing plan. Air pressures and cleanliness testing, although good measures of conditions, are not required for other oral products. A qualification or facilities testing program is usually beyond the scope of the specific process validation program.

*Purging.* Prior to compounding of batch ingredients, preparatory steps should be monitored. Any purging of tanks, lines, and so on with dry gas should be recorded for any filtration, flow rates, and position of gas lines. For many products it is desirable to purge the drug concentrate tank prior to and during batch preparation with an inert gas such as nitrogen. This serves to remove undesirable moisture and oxygen in the tank head space. The type of gas and any treatment such as drying agents or filtration should be verified during validation. Frequently stainless steel piping or tees into tank covers are employed to introduce dry nitrogen NF into the tank. The source and grade (e.g., high purity nitrogen) should be documented, along with details of the method and position of purging the tanks.



*Recirculation.* Recirculation of drug concentrate may be used during the filling operation to maintain a sufficient source to the filling device. Concentrate may be pumped between the drug suspension or solution tank to the filling system, and then the excess is returned to the tank. The type, model, and serial number of pumping equipment and flow rates must be monitored. The time recirculation is started and stopped should be known. If alternative mechanisms such as a level controller (float valves) are used the settings should also be documented. In some instances a filter may be used for solution or suspensions. Similar to filtration of propellant, a challenge test of the filter with small particles may be conducted to demonstrate adequate retention. This would be described in a separate testing protocol, preferably during the development.

*Residual Losses and Yields.* The yield of the concentrate, filling, and any residual tank or pumping loss is an important measure of how the process behaved. Accounting for drug suspension and solution should be complete and rigorously done. An investigation of losses should be made when these losses exceed unusual amounts (about 5–7%) of the drug suspension or solution. Tentative specifications of the yield should be considered after the validation batches and reviewed after several more production batches are made.

## 2. Aerosol Line Functions

The amount and type of purge at the can vacuum station (can cleaning) should be known. The pressure and amount of vacuum applied to the empty can should also be measured. A challenge test may be done in which particulates are intentionally placed into empty cans to observe visually the removal of the foreign contaminants. As for a filtration challenge, a brief protocol should be written if this is elected. While filling the cans with appropriate drug solution or suspension, any items not written in the batch directions, line setup, or other batch records should be reported during validation. For example, any special nitrogen shroud assembling for environmental control or other devices for filling accuracy should be known.

In addition, during validation an entire group of cans may be isolated for each filling nozzle in between check weighing intervals. For example if every 500th is manually check weighed, then a group of 500 cans should be separated and passed individually through the check weigher to verify the in-between values. Also, the filling variation, such as standard deviation, should be calculated for each filling nozzle or piston. Relative standard deviations of less than 3% are considered acceptable, although values of less than 1.5% should be a goal. The type and amount of gas purged into the canister will be verified during validation. The location at which this is done on the line is recorded, and the time and after purging is known. The flow rate of the gas into the can as well as the position inside the can is also known.

The method of valve placement after filling and equipment specifics must be documented.

*Crimping.* Since crimping is delicate and complicated, this step will require more attention than others [23]. The specific equipment, such as collet numbers, settings of pads, or downward head pressures, must be known. The details should be clearly spelled out in product setup documents, especially if different personnel are used among the validation batches. Several measurements are used to evaluate the valve crimp. Specifications for these measurements should be set, along with acceptable leakage or weight loss data justifying these crimps and their measurements. Valve delivery such as that measured by spray weights should also be recorded to verify that the operation of the valve is not affected by the crimping step. During validation batches, crimp measurements should be taken at specified intervals to ensure an acceptable and reproducible process step. Statistical sampling would be best, such as samples taken hourly during the duration of the batch. Alternatively, groups of 12 cans at the beginning, middle, and end of the batch may be done. This will ensure statistical equivalence throughout the batch. Pressure settings on the crimping equipment are to remain unchanged. Any change in settings will necessitate resampling and retesting to verify the new settings.

*Propellant Filling.* Propellant filling must likewise specify the setup and any important quantitative values of this process step. Pressure testing verifies that the proper propellant is utilized. The type of equipment, (e.g., cylinder and piston type, size, injection head nozzle, O-ring specifics, and special features) should be well known as for concentrate filling. Settings of downward pressure and injection pressure must conform. The propellant filling step should be individually validated, as is done for the concentrate filling. Control charts for propellant fill weights should be included in the validation batches. These will verify that specifications are met and adequate control limits have been determined. The process capability may also be determined from the individual weights.

*Check Weighing.* Check weighing of all cans after the unit is crimped and filled must not be neglected. The type and orientation of cans, ranges set, speed of check weighing, and an appropriate challenge of the accuracy of the check weigher must be monitored. The type and line position of the check weigher need to be verified. The weight ranges, zones, and can feed rate should be written. The number of rejects (high and low) should be part of the batch reconciliation documentation. After validation, a good grasp of the usual allowable rejects will be available. Any inconsistencies should be traced to the specific filler. The weight rejects may also be individually weighed on a sensitive balance to confirm the accuracy of the check weigher. Cans for setting the check

weigher with heavy and light filled units are frequently used, as well as empty units for taring.

*Leak Testing.* Leak testing, like check weighing, will have its specified conditions that do not affect the product but similarly allow for inspection of faulty units. The temperature for the can and the duration must be described in the batch directions and confirmed during validation. Sometimes one may wish to know the temperature the product reaches. Thermocouples or temperature indicators may be used to assess this. All cans are leak tested to cull out any faulty units that may leak in the field. For example, submersion at 120°F for 3 min may be adopted, since the contents may approach that temperature after that time. The labeling and regulatory requirements (department of transportation) may best be applied here. A desired temperature should have a temperature range and time range. It must also be verified that this step does not alter the quality and stability of the dosage form. Immediately after the test, the units may remain warm for a given period of time. The cans should not be further processed (spray testing), but should be allowed to cool to room temperature. Frequently, for small MDI units, 1/2 to 1 hr is usually sufficient.

### 3. Other Line Functions

Storage of the aerosol product after filling must be described in the batch records. Sometimes the cans are stored valve down (for seating the valve gaskets) or valve up to minimize exposure to leachables in the rubber componentry. The shipper description should be in the bill of materials packet. Spray testing is a critical step to prevent continuous or no-fire units from reaching the customer. All units are tested during the filling operation or during the packaging operation. Process monitoring may encompass verifying the proper number of valve depressions for testing, challenging the method with intentionally faulty units, and establishing the normal expected reject rate for a given valve in the validated process. The number of depressions of the valve is more descriptive than the number of sprays. The first valve depression of a new unit is frequently a prime, nonspraying shot. The actuator used should be specified in the batch records. If a manual inspection system is utilized, proper training of operators must be conducted. Actuators should be used only for a given period of time before being replaced with new ones. A history of the particular valve's defects and frequency should be known before validation of production-size batches begin.

Other functions such as can coding (lot numbers, line designation) must be considered a process step. Can coding is a means of identifying an unlabeled unit by lot number or code. It is usually done with an ink-jet labeler or similar device. Another coding system may differentiate between filling tracks (front, back) within one lot. For example, if needed, the back track may be coded with

a small black mark to differentiate it from the front tract. These code marks are covered with the can label during that operation.

## VI. VALIDATION REPORT

The validation report should contain the approved validation protocol, tabulated or graphical results, process monitoring (forms), and all analytical results of the validation batches. A copy of the batch records and raw material releases may be in the appendix, although this usually adds considerably to the size of the report. The presentation of data should be spread out over many pages and be easily understood and neat. Small tables of process conditions or data should be in one style that appears concise and is easily read. Stability data can be amended at a later date if desired. Special investigations or additional tests or retests may have to be explained in the report if deviations of any kind occurred. The validation report should have a conclusion that explains the manufacturing specialist's (preparer's) statement and opinion. Appendices may be used to explain detailed equations (e.g., control chart statistics) or specific methods (e.g., spray delivery methods). Information that is included in the batch records may not have to be repeated, but in some instances (e.g., crimp measurements) may be beneficial for presentation. The use of figures or graphs is strongly suggested because these plots may show some trends and insights from a large database. Recommendations may also be made in the report, such as preparing more batches, amending certain tests, expanding batch directions, or creating alert limits.

The validation report should be approved prior to product distribution and kept permanently on file in quality assurance. Furthermore, production should not commence until the validation report is approved. The data in the report should serve as a foundation for future troubleshooting; that is, they should be specific enough, along with the batch directions, for the process to be easily duplicated. Any equipment qualification reports, such as filling equipment, crimper, check weigher, homogenizer, or propellant gasser, should likewise be readily available if this is warranted. *Stability testing on all validation batches* must be performed according to the protocol, according to the NDA/ANDA stability plan.

The delivery of drugs to the respiratory system via an MDI has been the dosage form of choice for over 50 years. Propelled with CFCs, they have had a remarkable safety record and acceptance by both patient and physician. The development, production, and marketing of this dosage form has resided in a very limited number of pharmaceutical companies. With the phase-out of CFCs and the introduction of the more environmentally acceptable HFA propellants, a newer and different technology is emerging that affects all aspects of this

exciting area. While the patient and physician acceptance of the HFA formulation for MDIs has been less than expected (due to different taste, feels, cost, etc.), and limitations on the formulations have been discouraged or limited by several patents this never the less is the direction for the future and hopefully technology will emerge to overcome these present-day shortcomings.

## REFERENCES

1. Kanig, J. L., Pharmaceutical aerosols. *J Pharm Sci* 52:513–553 (1963).
2. Sciarra, J. J. Pharmaceutical and cosmetic aerosols. *J Pharm Sci* 63:1815–1837 (1974).
3. *Physician's Desk Reference*. 55th ed. Montvale, NJ: Medical Economics Co. (2001).
4. Pengilly, R. W., Keiner, J. A. The influence of some formulation variables and valve actuator designs on the particle size distributions of aerosol sprays. *J Soc Cosmet Chem* 28:641–650 (1977).
5. Hickey, A. J. *Pharmaceutical Inhalation Aerosol Technology*. vol. 54. New York: Marcel Dekker (1992).
6. U.S. Food and Drug Administration. *Guidance for Industry: Metered Dose Inhaler (MDI) and Dry Powder Inhaler (DPI) Drug Products (Draft)*. Center for Drug Products (Draft). Center for Drug Evaluation and Research (Oct. 1998).
7. Sciarra, J. J. Pharmaceutical aerosols. In: G. S. Banker, C. T. Rhodes, eds. *Modern Pharmaceutics*. vol. 72, 3rd ed. New York: Marcel Dekker, pp. 547–574 (1996).
8. Polli, G. P., Grim, W. M., Bacher, F. A., Yunker, M. H. Influence of formulation on aerosol particle size. *J Pharm Sci* 58:484–486 (1969).
9. Hallworth, G. W., Padfield, J. M. Comparison of the regional deposition in a model nose of a drug discharged from metered-aerosol and metered-dose nasal delivery systems. *J Allergy Clin Immunol* 77(2):348–353 (1986).
10. Physical tests and determinations: <601> aerosols. *The United States Pharmacopeia (USP)*. vol. 25. Rockville, MD: U.S. Pharmacopeial Convention (2001).
11. Kibbe, A. H. *Handbook of Pharmaceutical Excipients*. 3rd ed. Washington, DC: American Pharmaceutical Association, pp. 134, 234, 560 (2000).
12. Gorman, W. G., Popp, K. F., Hunke, W. A., Miriani, E. P. Process validation of aerosol products. *Aerosol Age* 32(3):24–28 (1987).
13. Hallworth, G. W. The formation and evaluation of pressurized metered-dose inhalers. In: I. Gandeston, I. Jones, eds. *Drug Delivery to the Respiratory Tract*. Chichester, UK: Ellis Horwood, pp. 87–118 (1987).
14. Cutie, A., Burger, J., Clawans, C., Dolinsky, D., Feinstein, W., Gupta, B., Gruenberg, A., Sciarra, J. Test for reproducibility of metered-dose aerosol valves for pharmaceutical solutions. *J Pharm Sci* 70:1085–1087 (1981).
15. Fiese, E. F., Gorman, W. G., Dolinsky, D., Harwood, R. J., Hunke, W. A., Miller, N. C., Mintzer, H., Harper, N. J. Test method for evaluation of loss of prime in metered-dose aerosols. *J Pharm Sci* 72:90–93 (1988).

16. Cyr, T. D., Graham, S. J. Low first-spray drug content in albuterol metered-dose inhalers. *Pharm Res* 8:658–660 (1991).
17. Benjamin, E. J., Kroeten, J. J., Shek, E. Characterization of spray patterns of inhalation aerosols using thin-layer chromatography. *J Pharm Sci* 72:380–385 (1983).
18. Miszuk, S., Gupta, B. M., Chen, F. C., Clawans, C., Knapp, J. Z. Video characterization of flume patterns of inhalation aerosols. *J Pharm Sci* 69:713–717 (1980).
19. Dhand, R., Malik, S. K., Balakrishnan, M., Verma, S. R. High speed photographic analysis of aerosols produced by metered dose inhalers. *J Pharm Pharmacol* 40:429–430 (1988).
20. Cutie, A., Ertifaie, S., Sciarra, J. J. Aerosolized drug delivery accessories, *Aerosol Age* 27(4):21–30 (1982).
21. Sciarra, J. J. and Sciarra, C. J. Aerosols. In: *Remington: The Science and Practice of Pharmacy*. 20th ed. Baltimore: Lippincott Williams and Wilkias (2000).
22. Bozzone, S. Validation of inhalation aerosols. In: R. R. Berry, R. A. Nash, eds. *Pharmaceutical Process Validation*. vol. 57, 2nd ed. New York: Marcel Dekker (1993).
23. Haase, F. D. Techniques of crimping and clinching: An overview. *Aerosol Age* 32(1):21–24 (1987).
24. Induction heating tests aerosols in pharmaceutical operation. *Aerosol Age* 27(1):14–17 (1982).
25. Mintzer, H. Scale-up and production considerations for therapeutic aerosols. *Aerosol Age* 30(3):22–24 (1985).
26. Miller, N. C., Schultz, R. K., Schachtner, W. J. Through-life dose uniformity in pressurized metered dose inhalers. *Pharm Res* 7(9, suppl.):S–88 (1990).
27. Ranucci, J. A., Dixit, S., Bray, R. N., Goldman, D. Controlled flocculation in metered-dose aerosol suspensions. *Pharm Tech* 14(4):68, 70–72, 74 (1990).
28. Schultz, R. K., Miller, N. K., Christensen, J. D. Method for evaluation of suspension characteristics relevant to metered dose inhaler formulations. *Pharm Res* 7(9, suppl.):S–88 (1990).
29. U.S. Food and Drug Administration. *Guideline on General Principles and Process Validation*. Center for Drugs and Biologics and Center for Devices and Radiological Health, Rockville, MD. p. 4 (May 1987).

# 11

## Process Validation of Pharmaceutical Ingredients

**Robert A. Nash**

*Stevens Institute of Technology, Hoboken, New Jersey, U.S.A.*

This chapter reviews the requirements of the U.S. Food and Drug Administration (FDA) for process validation of manufacturing pharmaceutical active ingredients (APIs) and inactive ingredients used in human and veterinary drug products.

The Food, Drug, and Cosmetic Act (FD&C Act) defines drug as (clause A) articles recognized in the official U.S. Pharmacopeia, official Homeopathic Pharmacopeia of the United States, official National Formulary, or any supplement to any of them; (clause B) articles intended for use in the diagnosis, cure, mitigation, treatment, or prevention of disease in man or other animals; (clause C) articles (other than food) intended to affect the structure or any function of the body of man or other animals; and (clause D) articles intended as a component of any articles specified in clauses A, B, or C.

Based on the above definition, active ingredients, excipients, coloring agents, flavors, and in-process materials are components of a drug and therefore are subject to the same drug laws in the FD&C Act. One such law, Section 501(b), declares a drug to be adulterated if the method used in or the facilities or controls used for its manufacture, processing, packing, or holding do not conform to or are not operated or administered in conformity with current good manufacturing practice (CGMP) to assure that the drug meets the requirements of this act as to the safety, has the identity and strength, and meets the quality and purity characteristics that it purports or is represented to possess.

The FDA publicly committed to develop a CGMP regulation for bulk

drugs on September 29, 1978, when the 1978 amendments to the CGMP regulations (Title 21 of the Code of Federal Regulations, Parts 210 and 211) were published in the *Federal Register*. Page 45050 of the preamble to this final rule stated that the CGMP regulations “apply to finished dosage form drugs (under §§ 210.3(b)(4) and 211.1) and are not binding requirements for chemical manufacturing.” It further explained that the CGMP regulations for finished pharmaceuticals “can serve as useful guidelines in the manufacture of chemicals,” and specified “The agency plans to develop specific CGMP regulations on production of bulk drugs.”

In its guideline to inspection the FDA set the following criteria to identify an industrial chemical as a bulk pharmaceutical chemical (BPC) (FDA, 1991):

- When there is no recognized nondrug commercial use for the chemical
- When it reaches the point in its isolation and purification at which it is intended that the substance will be used in a drug product
- When the manufacturer sells the product or offers it for sale to a pharmaceutical firm for use in a drug product

Active and excipient chemical ingredients used in drug products may therefore be considered as BPCs. These materials can be made by chemical synthesis, fermentation, enzymatic reactions, recombinant DNA, recovery from natural materials, or a combination of the above.

In the mid-1990s the term active pharmaceutical ingredient (API) was introduced by the FDA to replace the term bulk pharmaceutical chemical (BPC).

Excipients are used in drug substance formulations to provide an acceptable drug product. The FDA considers excipients as BPCs, but has not issued specific GMP regulations for them. The International Pharmaceutical Excipient Council (IPEC), however, issued a proposed GMP for excipients in 1995 and a guide, “Significant Change for Bulk Pharmaceutical Excipients” BPEs, in the year 2000.

Active pharmaceutical ingredients are most often manufactured in batch or semicontinuous process since most APIs are potent and normally used in relatively small amounts in each batch of drug product, especially during the early phase of drug product introduction. With the advent of many new APIs, the capital investment for continuous operation is not economically feasible. In a batch process, the product is often made from a well-identified, approved raw material supply, which is usually present at the start of the reaction.

Most drug product manufacturers use the same excipients, and usually in relatively high concentrations in the drug product when compared to the concentration of the API. The manufacture of excipients therefore often involves continuous processing. A continuous process is one in which material (both raw and/or in-process) is added continually as the finished product is removed for



further processing or is collected for packaging. A continuous process may involve manufacture in a continuous reactor, in which unique identification or traceability of raw materials is not feasible. Continuous processing can involve a batch reaction, in which the identification of the reactants is clearly known but in which further processing, such as purification or drying, may be done in a continuous fashion. The excipients are often manufactured on a scale sufficiently large to justify continuous processing, often because of their other non-pharmaceutical applications; for example, at a rate of 100,000 kg/shift, where only 10% is allocated to the pharmaceutical industry and the rest for commercial purposes. One of the main drawbacks of continuous processing is that the quality of a material produced by such a process in terms of the uniformity of both the impurity profile and physical properties is more difficult to accomplish when compared to material produced by batch processing.

The FDA believes that the general principles of validation apply to any process and that these principles don't change from process to process. The specific type of validation or degree of validation differ for API processes when compared to those required for drug products. In the production of dosage forms, all manufacturing steps (unit operations) in the production of the final product, such as cleaning, weighing, measuring, mixing, blending, packaging, and labeling, are encompassed by process validation.

For API processes, the FDA does not expect validation of all manufacturing steps, but accepts validation of critical process steps. Section XI.A of the March 1998 draft API guidance document states, "Validation should embrace steps in the processing of APIs that are critical to the quality and purity of the final API." The FDA, however, does not specify what it considers critical, but wants the manufacturer to determine the critical process steps and critical process parameters. For new chemical entities, data used to identify critical processing steps and critical parameters would be derived from research or pilot scale batches. For established API processes this information could be obtained from previously manufactured production scale batches.

According to Rivera Martinez, critical steps are not limited to the final API stage and can include intermediate steps that introduce an essential molecular structural element, result in a major chemical transformation, introduce significant impurities, or remove significant impurities.

Critical process steps are usually determined by analyzing process parameters (factors in a process that are controllable and measurable) and their respective outcomes. Not all process parameters affect the quality and purity of APIs; namely its impurity profile and physical characteristics. For validation purposes, manufacturers should identify, control, and monitor critical process parameters that may influence the critical quality attributes of the API. Process parameters unrelated to quality, such as variables controlled to minimize energy consumption or equipment use, need not be included in process validation.

An approach to identify critical process parameters involves conducting “critical step analysis” in which API manufacturers challenge the unit operations (e.g., reaction step, crystallization, and centrifugation) during the process qualification stage to determine those critical process variables that may affect overall process performance. Process validation should confirm that the impurity profile for each API is within the limits specified. The impurity profile should be comparable to or better than historic data, the profile determined during process development or batches used for pivotal clinical, and toxicological studies.

## I. IMPURITY PROFILE

The FDA guidance document on impurities in drug substances recommends that individual impurities greater than 0.1% should be fully characterized and quantified by a validated analytical method. In addition, the USP permits up to 2% of ordinary nontoxic impurities in APIs. Such impurities may include: residual starting materials, intermediates, reagents, by-products, degradation products, catalysts, heavy metals, electrolytes, filtering aids, and residual solvents.

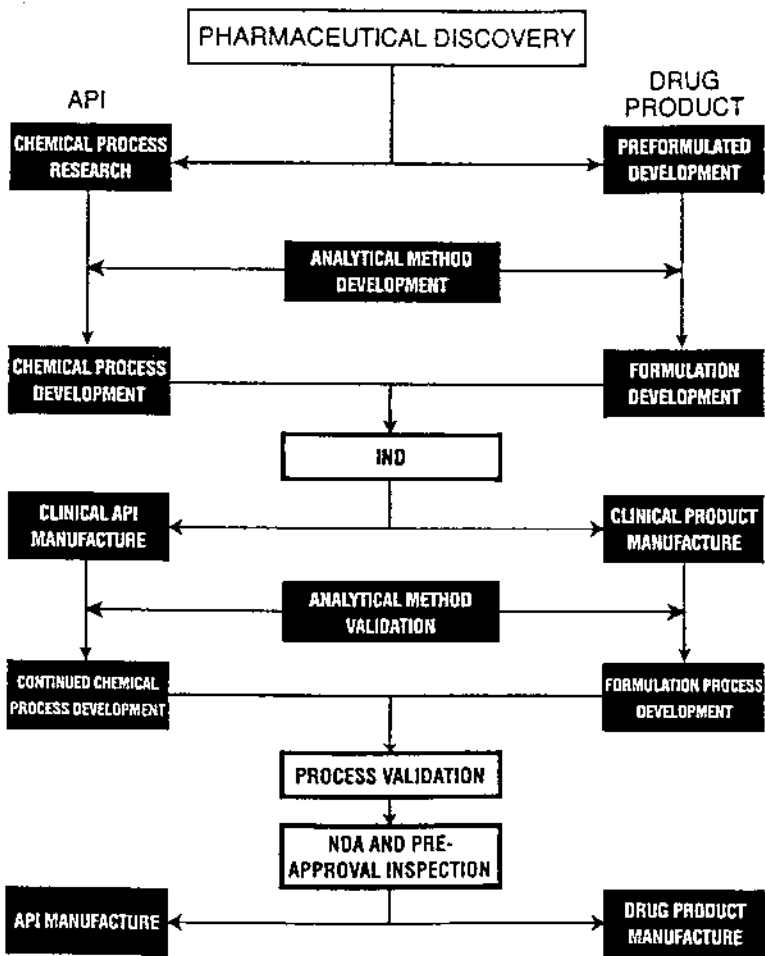
Known toxic impurities, however, should be held to a tighter standard (below 0.1%). One of the objectives of a successful validation program for APIs is to maintain control over the impurity profile and to hold contaminants and impurities to an achievable minimum standard.

For each batch of API produced, the following information should be supplied in the batch completion report:

- Batch identity and size
- Date of manufacture
- Site of manufacture
- Specifics of the manufacturing process
- Impurity content (individual and total)
- Reference to analytical procedures used
- Disposition of the batch

In summary, the drug substance acceptance criteria should include information with respect to organic impurities, residual solvents, and inorganic impurities. Similar standards should also be applicable to pharmaceutical excipients.

Figure 1 shows the use of a single analytical method function as an important technical bridge between the API and the drug product as they move through the various stages of development, clinical study, process development, and process validation into production.



**Figure 1** Working in parallel. (Courtesy of Austin Chemical Co., Inc.)

## II. ACTIVE PHARMACEUTICAL INGREDIENT

Presently the overwhelming number of APIs are organic, carbon-based, chemotherapeutic agents prepared by either chemical synthesis or fermentation techniques or are isolated from natural products. More than 90% of the active drug

substances are solids, the majority of which are white and crystalline, and with a well-defined melting point or range. The rest are liquids at room temperature, while a few are medicinal gases.

The organic chemical structures of most active drug substances are composed of carbon, hydrogen, oxygen, and nitrogen atoms and may contain an occasional sulfur, phosphorus, or halogen (fluorine, chlorine, bromine, and iodine) in the specific chemical configuration. The molecular weights of most APIs range from 100 to 1000 but tend to be about 300 daltons. Melting points range between 100 and about 300°C.

Active pharmaceutical ingredients belong essentially to one of the following four basic chemical classes:

1. *Weak acids and their salts* (sodium sulfacetamide, potassium guaia-colsulfonate, calcium fenoprofen, magnesium salicylate, etc.) approximately 30%
2. *Weak bases and their salts* (nortriptyline hydrochloride, phenelzine sulfate, chloroquine phosphate, scopolamine hydrobromide, tamoxifen citrate, etc.) approximately 45%
3. *Organic nonelectrolytes* (neutral molecules, chloral hydrate, hydrocortisone, testosterone, mannitol, etc.) approximately 15%
4. *Quaternary compounds* (substituted ammonium salts, methacholine chloride, mepenzolate bromide, phospholine iodide, etc.) approximately 10%

Weak acids and weak bases and their salts account for about 75% of the APIs currently used in drug products.

*Prodrugs* are drug substances that are biotransformed in the body to active metabolites and chemotherapeutic agents. Examples include sulfasalazine to sulfapyridine, phenylbutazone to oxy-phenbutazone, aspirin to salicylate, and hetacillin to ampicillin. In some cases, such as aspirin (ester) and hetacillin (amide), hydrolysis in water releases the active drug moiety contained within the basic structure of the prodrug.

The FDA often considers such simple, uncomplicated amides, lactams, esters, and lactones as derivatives of the active drug substance in the same way as it treats salts (electrolytes) and ion-pair complexes (nonelectrolytes) of the same basic chemical structure.

The FDA principle “You are what you claim you are” applies to APIs as well as to foods, drugs, and cosmetics.

Take, for example, dextrose. When dextrose is used as a sweetener in baked goods, it is a food ingredient and subject to the requirements of food products. When dextrose is used as a sweetener or diluent in tablet, capsule, or liquid preparations, it is an excipient. When it is used in the manufacture of sterile dextrose injection, it is an active drug substance and an API but now

subject to assay and testing for bacterial endotoxins and 5-hydroxymethyl furfural content.

Pharmaceutical excipients (inactive ingredients) are substances other than the active drug substance or the drug product that have been evaluated for safety and are included in the pharmaceutical dosage form (drug delivery system) for one or more of the following functions:

1. Aid in the processing of the drug product during manufacture (e.g., binder, disintegrant, lubricant, suspending agent, filtering aid)
2. Protect, support, or enhance stability, bioavailability, or patient acceptability (e.g., chelant, surfactant, sweetener)
3. Assist in product identification (e.g., colorant, flavor, film former)
4. Enhance any other attribute of the overall safety and effectiveness of the drug during storage or use (e.g., inert gas, preservative, sunscreen)

Like APIs, pharmaceutical excipients are made by chemical synthesis, fermentation, recovery from natural materials, and so on. Often purification procedures may not be employed in the manufacture of such pharmaceutical excipients as clays, celluloses, starches, and natural gums. In addition, the physical and chemical change of certain excipients during processing is not uncommon. Unlike APIs, many excipients have complicated chemical and physical structures that do not yield easily to modern analytical and chromatographic methods.

More than 200 monographs of pharmaceutical excipients appear in the third edition of the *Handbook of Pharmaceutical Excipients*, published jointly by the American Pharmaceutical Association and the Pharmaceutical Press in the year 2000. In addition, more than 200 of the same pharmaceutical ingredients (excipients) are listed in NF 19 and cover more than 40 different excipient categories, from acidulants to wetting agents. It has been estimated that there are more than 1000 different pharmaceutical excipients in use worldwide at the present time.

The International Pharmaceutical Excipient Council in the United States (Arlington, Virginia; 703-521-3338) has issued a GMP guideline for excipient bulk pharmaceutical chemicals. In conjunction with both the European and Japanese Pharmaceutical Excipient Councils, the council is currently engaged in establishing international harmonization excipient monographs for the more popular pharmaceutical excipients. A list of important and popular pharmaceutical excipients is given in [Table 1](#).

Basic information with respect to GMPs for APIs is covered in the following recently issued technical guidance documents:

“PhRMA Guideline for the Production, Packing, Repacking or Holding of Drug Substances (APIs).” *Pharmaceutical Technology* (Dec. 1995/Jan. 1996).

**Table 1** Fifty Most Commonly Used Excipients in Drug Products

Pharmaceutical excipient	Function	Pharmaceutical excipient	Function
Acesulfame potassium	Sweetener	Kaolin	Drying agent
Alcohol	Solvent	Lactic acid	Acidifier
Alginic acid	Suspending agent	Lactose	Diluent and filler
Benzalkonium chloride	Preservative	Magnesium stearate	Tablet lubricant
Benzyl alcohol	Preservative	Methyl paraben	Preservative
Bentonite	Suspending agent	Microcrystalline cellulose	Tablet binder
Carbomer	Tablet binder	Mineral oil	Solvent
Carboxymethylcellulose sodium	Suspending agent	Petrolatum	Vehicle
Carrageenin	Suspending agent	Pregelatinized starch	Tablet disintegrant
Cellulose acetate phthalate	Coating agent	Polyethylene glycol 400, 3350	Vehicle
Citric acid	Acidifier	Polyoxyethylene alkyl esters	Surfactant
Colloidal silicon dioxide	Tablet glidant	Polysorbate 80	Surfactant
Croscarmellose sodium	Tablet disintegrant	Shellac	Coating agent
Crospovidone	Tablet disintegrant	Sodium chloride	Osmotic agent
Dibasic calcium phosphate	Tablet binder	Sodium hydroxide	Alkaline agent
Disodium edetate	Chelating agent	Sodium saccharin	Sweetening agent
Docusate sodium	Surfactant	Sodium starch glycolate	Tablet disintegrant
Ethyl cellulose	Coating agent	Starch (corn, wheat, potato, rice)	Tablet filler
Gelatin	Coating agent	Stearic acid	Tablet lubricant
Glycerin	Solvent	Stearyl alcohol	Viscosity agent
Hydrochloric acid	Acidifier	Sucrose	Sweetener
Hydroxyethyl cellulose	Coating agent	Talc	Glidant
Hydroxypropyl cellulose	Coating agent	Triacetin	Solvent
Hydroxypropyl methylcellulose	Coating agent	Titanium dioxide	Opacifier
Isopropyl alcohol	Solvent	Xanthan gum	Suspending agent

*Source:* Data supplied by the International Pharmaceutical Excipient Council.

European Chemical Industry Council/European Federation of Pharmaceutical Industries Association. *GMP Guide* (Aug. 1996).

FDA's manufacturing, processing, or holding APIs draft guidance, issued March 1998.

The Pharmaceutical Inspection Convention API guide (revised April 1998).

International Conference on Harmonisation (ICH). *GMP Guide for APIs* (Nov. 2000).

GMP guide for APIs issued by the World Health Organization (WHO) in July 2001 (also reflects ICH guidance documentation).

In addition, specialized guidance information has also been issued for the following topics:

ICH. *Guidance for Industry: Q1B Photostability Testing of New Drug Substances and Products* (Nov. 1996).

FDA. *Guidance for Industry, ANDAs: Impurities in Drug Substances* (June 1998).

FDA. *Guidance for Industry, BACPAC I: Intermediates in Drug Substance Synthesis* (Feb. 2001).

Guidance documents do not have the same weight and standing as such regulations as 21 CFR 211 (cGMPs), but they do reflect the best thinking of the regulatory authority with or without the formal support of the industry covered by the guidance information. If a particular company can provide solid scientific support for the approach the company is taking, which may differ from the information provided in the guidance document, in most situations it should be acceptable to the regulatory agency.

The ICH guidance document covers the following essential topics:

Introduction (object and scope)

Quality management (internal audits and reviews)

Personnel (qualifications, hygiene, and consultants)

Building and facilities (design, construction, water, containment, lighting, sewage, and sanitation)

Process equipment (design, construction, maintenance, cleaning, calibration, and computerized systems)

Documentation and records (systems, specifications, raw materials, intermediates, labeling, packaging materials, master production and batch records, laboratory control records, batch production record review)

Materials management (receipt, quarantine, sampling, testing, storage, and re-evaluation)

Production and in-process controls (unit operations, time limits, in-process sampling, blending of intermediates or APIs, contamination control)

Packaging and identification of APIs and intermediates

Storage and distribution (warehousing and distribution)

Laboratory controls (testing of intermediates and APIs, validation of analytical procedures, certificates of analysis, stability monitoring of APIs expiry dating, retention samples)

Validation (policy, documentation, qualifications, approaches to process validation, periodic review of validated systems, cleaning validation, and analytical methods validation)

Change control

Complaints and recalls

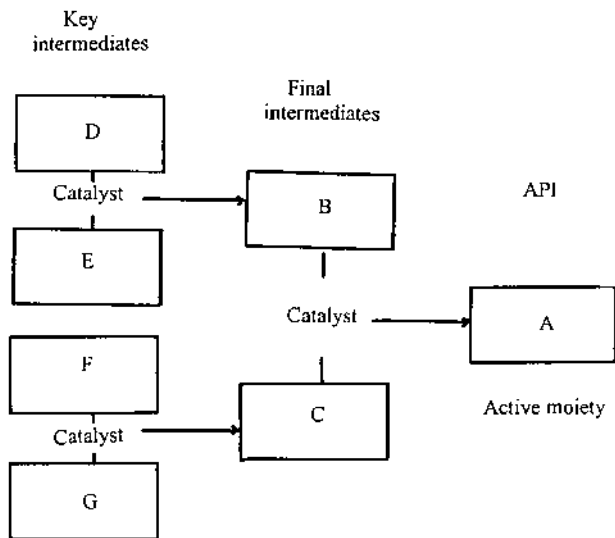
Contract manufacturers and laboratories

Agents, distributors, repackers, and relabelers

Specific guidance for API manufacture by cell culture or fermentation

APIs for use in clinical trials (quality, equipment, facilities, control of raw materials, production, validation, change control, laboratory controls, and documentation)

In most synthetic chemical reactions, the processes involved have been simplified. (See Fig. 2.) Process validation should be conducted for the final active drug moiety or API (A), the final intermediates (B and C), as well as the key intermediates (D and E) that produced B and the key intermediates (F and G) that produced C. Final product (A) and final intermediates (B and C) should



**Figure 2** Pathway to API process validation.



be subjected to major in-process testing for identity, strength, potency, and purity, while key intermediates (D, E, F, and G) should be held to somewhat less intensive in-process testing for identity, strength, potency, and purity.

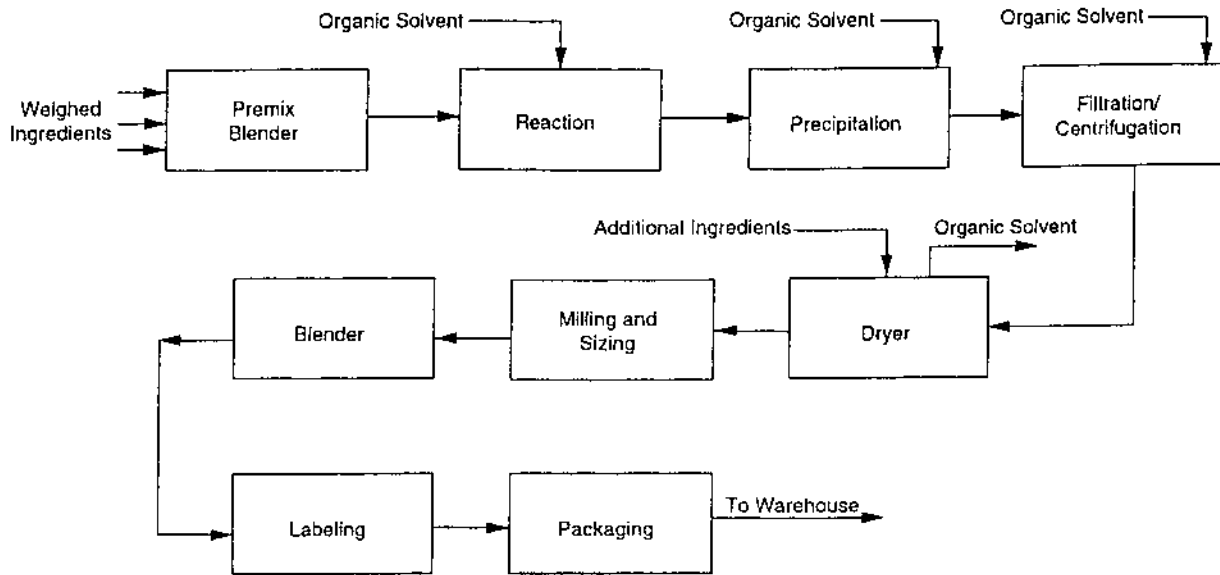
If earlier intermediates in the chain are also produced in the same plant, they should not be held to the same rigorous chemical, physical, and microbiological standards that were used to produce the key intermediates, final intermediates, and final active moiety or API. Nevertheless, it would not be appropriate to have a plant produce both CGMP-compliant and non-CGMP-compliant materials without some reasonable GMP-type procedures and reasonable testing standards established for non-CGMP-compliant materials. Higher standards can be imposed on an outside manufacture or vendor of APIs if they are interested in obtaining your business at a reasonable price. In any event the emphasis will be placed upon your own quality control and quality assurance functions to make sure that the outsource company consistently produces product that meets the agreed-upon standards placed by your company on their materials.

Diagrams for a synthetic chemical, single reaction step process (Fig. 3) and a typical single product fermentation (Fig. 4) are taken from Wintner's excellent article ["Environmental Controls in the Pharm. Industry. *Pharm Eng* (April 1993)]. Both flow diagrams feature about the same number of unit operations and start with raw material weighing procedures. The essential difference between the two figures is that the fermentation process features sterilization, inactivation, and preservation unit operations.

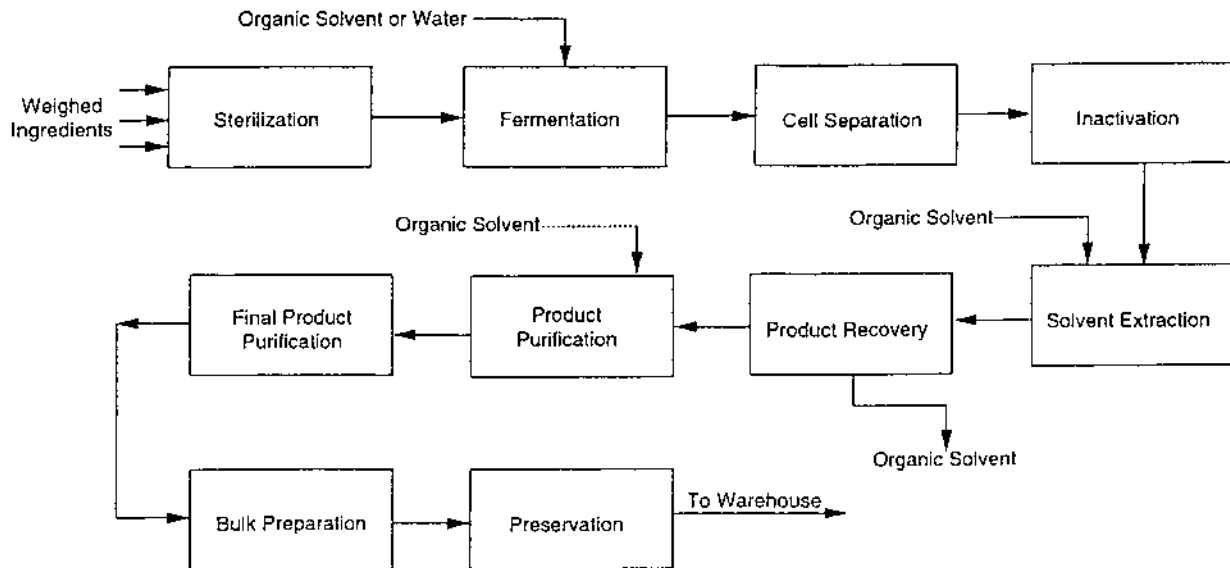
The *critical* unit operations that should be monitored and/or optimized are the *reaction* and *fermentation* steps for the purpose of *increasing API yield and reducing the residual impurity profile*. Other critical unit operations that are especially important to the end user (pharmaceutical dosage form operations) include precipitation or crystallization, milling, sizing, and purification operations, which may affect the physical properties (particle size and shape, bulk powder flow, blend uniformity, and compressibility) of the API.

Theoretically, every unit operation conducted in the plant comes under the CGMP umbrella, and is therefore subject to the need for validation documentation requirements. This includes not only the final API but also the manufacture of the *final intermediate(s)* (or main reactants), *key intermediates* that are used to prepare the final intermediate(s), all the way back to commercial starting materials that enter the plant, as well as the *pivotal intermediates* thereafter.

The level of control and validation documentation required (i.e., through increased testing and tighter specifications) increases as one moves closer, in a multistep, in-plant process, to the outcomes [i.e., final intermediate(s) and the API itself]. Naturally, when key and final intermediates are sourced from outside the company, they must enter with appropriate *certificates of analysis* (CofA), plus thorough inspections of off-site facilities by quality assurance personnel.



**Figure 3** API process. (Pharm Eng 13(4), 1993.)



**Figure 4** Typical fermentation API process. (Pharm Eng 13(4), 1993.)

**Table 2** Important Parameters to be Evaluated in the Reaction Step

Parameter	Outcome
Temperature	Yield and purity
Time	Yield and purity
Oxygen pressure	Yield and purity
CO <sub>2</sub> pressure	Yield and purity
Medium or solvents used	Yield and purity
Type, purity, and amount of catalyst used	Yield and purity
Type and speed of agitators	Particle size distribution
Reagent ratios	Particle shape and stereospecificity
Reagent purity	Catalyst performance
Reagent order and addition rate	Yield, purity, and morphology

Those unit operations, especially the reaction step(s) that are considered critical, are determined through the analysis of process variables or their respective measured responses or outcomes (Table 2). The most favorable operating conditions to run the reaction are usually worked out in the laboratory (1X stage) and refined and/or optimized in the pilot plant (usually at the 10X stage).

### III. API PREFORMULATION STUDIES

In order to develop a robust formula for a drug product (pharmaceutical dosage form) it is important to understand the chemical and physical properties of the API in conjunction with excipients that may be used to create the most stable product formula in terms of activity and potency. An outline of possible preformulation studies that should be conducted to ensure a proper and complete understanding of the chemical and physical properties of the API is presented in Table 3.

In addition, simple binary studies with key excipients should be done to establish physical and chemical compatibility between the API and the selected excipient. These studies need not be elaborate, but will provide useful information to the formulator during the critical drug product development stage.

### IV. THE VALIDATION OF APIs

According to the FDA's *Guidelines on General Principles of Process Validation*, the term process validation, whether for APIs or drug products, is defined as "establishing documented evidence, which provides a high degree of assur-

**Table 3** Compendial Tests and Standards for APIs

---

Aspect and macro appearance, including color, odor, and taste
Infrared and ultraviolet spectroscopy, including specific optical rotation, refractive index, and Raman spectral analysis
Particle morphology, including scanning electron microscopy
Particle size distribution, including light scattering methods and optical microscopy
X-ray diffraction
Thermal methods of analysis, including differential thermal analysis and differential scanning calorimetry (DSC)
Chromatographic identity and purity, including thin layer chromatography (TLC), gas chromatography (GC), and high-performance liquid chromatography (HPLC)
Loss on drying and moisture content (Karl Fischer)
Residue on ignition
Specific surface area (BET adsorption isotherm)
Bulk or apparent powder density (loose and tap)
Powder flow and compressibility characterization
Heavy metals and arsenic content
Solubility characteristics in suitable solvents, including color and clarity evaluation
pH value if API is soluble in water
Microbial limits testing

---

ance, that a specific process (i.e., the manufacture of an API) will consistently produce a product meeting its predetermined specifications and quality attributes.” The process for making an API consists of a series (flow diagram in logically defined steps) of unit operations (modules) that result in the manufacture of the finished API.

There is much confusion as to what process validation is and what constitutes validation documentation. We use the term validation generically to cover the entire spectrum of CGMP concerns, most of which are essentially facility, equipment, component, methods, and process qualification. The specific term process validation should be reserved for the final stages of the development and product scale-up sequence.

The end of the development and scale-up data generation sequence that should be assigned to the formal, protocol-driven, three-batch process validation derives from the fact that the specific exercise of process validation should never be designed to fail. Failure in carrying out the formal process validation assignment is often the result of incomplete or faulty understanding of process capability; in other words, what a given process can and cannot do under a given set of operational requirements. The formalized, final three-batch validation sequence is used to provide the necessary process validation documentation

required by the FDA to show API reproducibility and a manufacturing process in a state of control (Table 4).

## A. Recordkeeping

The first step toward validation is to establish a recordkeeping system that considers all aspects of the manufacturing process, including controls (or testing). A recordkeeping system must be established, if it does not exist already, to provide written records for the validation operations to be conducted. In order to duplicate a favorable result and prevent duplication of an unfavorable result, we must document the operations performed so that we have records that we can review, interpret, and pass judgment on. We cannot rely on memory and word of mouth. The system of recordkeeping has multiple facets.

1. *Standard operating procedures* (SOPs) are written procedures that describe how to perform basic operations in a plant. They explain certain minimum requirements to assure that there is a level of control

**Table 4** Summary of the FDA Guide to Inspection of API Manufacturing

---

1. Prevent contamination/cross-contamination (need separate air-handling system).
  2. Water systems/air quality (potable water acceptable for nonsterile operations).
  3. Aseptic/sterile processing. (EtO is acceptable.)
  4. Multipurpose equipment/cleaning/closed systems—acceptable for storage outdoors.
  5. Protect environment against waste.
  6. Cleaning of product contact surfaces (cleaning procedure/sampling plan/analytical method); limits: practical, achievable, and verifiable.
  7. Raw materials. (Storage inside and outside is acceptable.)
  8. Containers, closures, and packaging components.
  9. Mother liquors. (Secondary recovery is acceptable.)
  10. In-process blending/mixing. (Blending off out-of-spec material is not acceptable.)
  11. Reprocessing (investigation and reason for failure).
  12. Validation (variations that affect chemical/physical/microbial characteristics—establish relevance and reproducibility).
  13. Process change control system in place.
  14. Control product/process impurities.
  15. In-process testing.
  16. Packaging and labeling.
  17. Expiry dating and stability data.
  18. Laboratory controls and analytical methods validation.
- 

*Note:* Revised March 1998 and revised by the International Conference on Harmonization, Nov. 2000.

that is necessary to operate the process and as a foundation for validation. These procedures should be written in language that is simple enough for an untrained nonprofessional to understand. Also, any new personnel with minimal experience should be able to understand and follow these procedures. They are applicable to many different phases of a manufacturing operation.

- a. *Facilities*. One type of SOP applies to the physical facilities of the plant. Procedures must be written that include frequency and a list of what must be done and how it is to be accomplished. Often it is important to keep a log that indicates the dates on which certain operations are done and the individuals who perform the operations. Every plant is different, and the types of products manufactured in each facility may be totally different. Written SOPs must cover all operations performed within a plant, with emphasis given to preventing potential problems in a specific plant based on knowledge of the physical facility, the nature of the products and materials used, and the personnel employed.

There must be *cleaning procedures*; first, for cleaning the walls, floors, and ceilings. They must include frequency of cleaning, the different steps that are required, and the cleaning agents acceptable for use. Different areas within a plant will require different SOPs. For example, a sterile filling room will require more elaborate cleaning than a warehouse. A prototype SOP is illustrated in [Figure 5](#).

Another SOP category related to the physical facility is *environmental control*. All plants must be kept free of rodents and insects. Such an SOP will indicate acceptable materials to be used, precautions to prevent product and personnel contamination, frequency, and area-monitoring procedure. In some operations, such as an area to manufacture sterile products, there are requirements for control of air temperature, humidity, flow rates and patterns, and particulate matter. These SOPs require steps such as checks to be performed, including temperature reading and frequency, maintenance to be performed, such as changing air filters and frequency, recording instrument checks, and calibration, such as for temperature and frequency. A prototype SOP is illustrated in [Figure 6](#).

A third SOP category relating to the physical facility covers the plant *maintenance* function. The key consideration in these SOPs for manufacturing the highest-quality products most efficiently is preventive maintenance. Correcting a breakdown in a plant support system (e.g., a motor burned out because it was

XYZ CORPORATION  
STANDARD OPERATING PROCEDURE

---

TITLE: CLEANING PROCEDURE  
FOR PROCESSING DEPARTMENT

DATE APPROVED: 6-11-60  
PAGE 1 OF 1

---

DAILY (or as needed)

1. Mop floor in the morning and end of day, or as needed, with an approved detergent. Replace cleaning solution as needed when it becomes dirty. Floor must be clean when the department is shut down.
2. Sanitize the floor at least once daily with an approved disinfectant. The mop used for sanitizing should be placed in a pail of water and steam bubbled through for 15 minutes first.
3. Empty waste containers.
4. Wash countertops with a solvent such as isopropyl alcohol.
5. Inspect bulk drums and tanks - top and exterior walls - and wipe with a solvent.
6. All spills must be wiped up immediately.
7. All waste should be deposited in the proper trash receptacles provided.

WEEKLY

1. Wash plastic entrance curtains with an approved detergent.
2. Sanitize sink with an approved disinfectant.

Record checks in the attached log.

---

ISSUED BY:

JJ  
AL

APPROVED BY

EM  
LS

---

**Figure 5** Facility cleaning procedure.



XYZ CORPORATION  
STANDARD OPERATING PROCEDURE

---

TITLE: CLEANING PROCEDURE  
FOR PROCESSING EQUIPMENT

DATE APPROVED: 10-15-72  
PAGE 1 OF 1

---

1. All equipment is maintained in a clean and sanitary manner.
2. All equipment is checked for cleanliness before use.
3. After equipment is cleaned it is tagged "Clean." Used equipment is tagged "To Be Cleaned." This equipment includes tanks and mixers. Batch identification labels are not removed from the tanks until the tanks are cleaned.
4. Records are maintained in log books for cleaning the tanks and mixers. The records include: date, product, lot number, equipment number, cleaned by, checked by.
5. After a batch is processed, the empty tank is cleaned with hot water, then with deionized water and air dried completely. Tanks with valves are then disassembled, steam-cleaned and reassembled dry.
6. All mixers are cleaned after use. The mixing blade is removed and cleaned with hot water, then with deionized water and dried completely with a clean and lint-free absorbant.
7. Utensils are cleaned with hot water, then deionized water and dried with a clean and lint-free absorbant or air dried.
8. All clean equipment and utensils are protected from accumulating dust in storage, either by a cover or by being placed in a drawer or cabinet.

---

ISSUED BY:  
LR  
AT

APPROVED BY:  
EM  
LS

---

**Figure 6** Equipment cleaning procedure.

never oiled) is not maintenance but repair, which is generally more costly. Preventive maintenance SOPs in a plant should cover the basic air-handling systems, water systems, such physical structures as walls and ceilings, the waste removal system, and the heating and cooling systems. They should include replac-

ing worn parts, lubrication, replacing filters, cleaning traps, and checking for leaks.

*Safety* represents the fourth type of SOP related to the general facility. When unsafe conditions are present in a plant, the probability that an accident will occur increases. Besides the fact that personnel will be affected detrimentally, an accident may occur and unknowingly affect a product batch. For example, a person carrying a container of waste material may slip and fall and simultaneously spill some waste into an open container of a product batch without being aware that this contamination has occurred. It is prudent to establish SOPs to include such safety concerns as clean up of spills; the importance of dry floors; the proper storage of hazardous materials, such as flammable solvents; personnel practices, such as running; emergency evacuation of the plant; and plant safety inspections. A program of SOPs such as these will also aid in increasing employee morale, as the employer shows that he is concerned about the personal well-being of the plant employees. High morale is a very important factor in producing quality products.

*Housekeeping* is the fifth category of SOP that relates to the basic facility. Housekeeping is concerned with keeping materials, especially those in storage, neat and orderly and always identifiable. Proper housekeeping provides better efficiency and minimizes mix-ups. A warehouse that is organized with pallets properly aligned and not tipped, with adequate aisle space to move materials and properly segregate different items, will be less apt to use unauthorized material or ship a customer the wrong product. In a label storage room that segregates labels well and in a neat and orderly manner, there will be small risk of the wrong label being issued. Issuing the wrong label for a product batch after a considerable investment in validating a process to produce the highest quality product is a very unfortunate problem and not an uncommon one. Housekeeping is important to all the operations conducted in a plant.

- b. *Equipment*. A second type of SOP relates to the equipment used to manufacture product batches. Equipment includes tanks; mixers; utensils; scales; pumps; measurement devices for temperature, pressure, and speed of movement; lyophilizers; tableting machines; ovens; mills; sterilizing chambers; encapsulators; filling machines; labelers; conveyor systems; laboratory instruments, such as pH meters, spectrophotometers, gas chromatographs; and HPLC systems.

One category of these SOPs describes equipment cleaning. The same type of information is required as in facility cleaning, except as related directly to the equipment involved. Standard operating procedures must describe what is to be done step by step, along with disassembly and assembly, frequency, and acceptable cleaning agents.

The third category of equipment SOPs describes *maintenance*. These SOPs are similar in nature except that they relate specifically to equipment used in production and testing. Highlights of these procedures include preventive maintenance by lubrication, replacement of worn parts, disassembly and cleaning, oil and filter changes, and inspection of problems.

Equipment *operation* is another category of these SOPs. This type of procedure is applicable to more complex types of equipment, but not to all. Obviously we would not need an operating procedure for a stainless steel tank, but would for a lyophilizer. These SOPs provide a detailed step-by-step sequence of operations to run a piece of equipment. They begin with equipment assembly, then operation, and finally equipment disassembly.

- c. *Calibration*. Standard operating procedures are needed for all measuring equipment. Temperature, pressure and speed of movement, and weights are typical measurements performed on production equipment. There are many different types of instruments in the control operations that perform measurements (e.g., pH, dissolution rate, chemical assays, tablet hardness, optical rotation, and optical density). Some measurements are taken routinely with a gauge (e.g., a thermometer) and some with recording devices (e.g., a temperature recorder). In either case, the gauge or recording device must be calibrated periodically with a reliable standard such as a National Bureau of Standards traceable source. An example of this type of SOP is illustrated in [Figure 7](#).
- d. *Personnel*. A third type of SOP relates to the personnel in a plant who are involved directly in the manufacturing and control process. We have described many different types of procedures and the steps to be performed. We have not indicated the personnel to be responsible for these operations, however. All personnel in a plant who are involved in the manufacturing process—especially production, maintenance, and control—should have specific written *job descriptions*. As part of the SOP system, these job descriptions must be very clear in indicating a person's responsibilities and duties. A porter must understand very clearly which areas are to be cleaned and how this is to be accomplished. A produc-

XYZ CORPORATION  
STANDARD OPERATING PROCEDURE

---

TITLE: CALIBRATION PROCEDURE FOR  
CONSTANT TEMPERATURE CHAMBERS

DATE APPROVED: 1-15-76  
PAGE 1 OF 1

---

All constant temperature chambers - including refrigerators, incubators, water baths, ovens, and autoclaves - will have their temperature monitored.

1. Once every day each chamber will be checked and the temperature recorded.

SPECIFICATIONS:

- a.  $5^{\circ}\text{C} \pm 3^{\circ}\text{C}$
  - b.  $32^{\circ}\text{C} \pm 2^{\circ}\text{C}$
  - c.  $37^{\circ}\text{C} \pm 2^{\circ}\text{C}$
  - d.  $40^{\circ}\text{C} \pm 2^{\circ}\text{C}$
  - e.  $45^{\circ}\text{C} \pm 2^{\circ}\text{C}$
  - f.  $121^{\circ}\text{C} \pm 2^{\circ}\text{C}$
2. Each chamber will contain a partial immersion thermometer in a container of fluid.
  3. Each thermometer will be calibrated quarterly using an NBS thermometer and noted in the attached log.
  4. If temperature is outside the acceptable range, notify the supervisor immediately.
  5. Any adjustment or maintenance is to be recorded in the log.

---

ISSUED BY:

ST  
RV

APPROVED BY:

EM  
LS

---

**Figure 7** Calibration procedure.

tion line operator must understand which lines to work on, what he or she is responsible for, and when to call on other employees. The operator must fully understand, for example, whether to clean a spill on the line or call a porter. In addition to knowing their duties, all individuals must be intimately familiar with the different SOPs that are required to perform their job. Standard

operating procedures should not be written to be kept in the company's files; they should be used by personnel performing their respective functions and at times even posted.

Other categories of personnel SOPs include *personnel practices and cleanliness*. In a pharmaceutical plant, there must be established rules and regulations regarding proper dress (e.g., uniforms and hats, safety glasses, hard hats, jewelry, smoking, eating and drinking, storage of personal articles, and hand washing). A very important SOP is the one that describes *personnel training*. All newly hired personnel should participate in training in their job responsibilities, all related SOPs, company rules and regulations, and CGMP regulations. After initial training there should be a continued routine program to emphasize the information that employees must not forget and to update any changes.

- e. *Control*. The last type of SOP includes procedures that are more general and not covered by the other three types. Many of these SOPs refer to basic good business principles and some relate to basic control of the manufacturing operation. These procedures include *receipt, sampling, and storage of components* to assure that every raw material and packaging component is inspected on receipt, sampled, stored on hold, tested and released, or rejected and placed in approved or reject storage; *stability testing* to assure that there are adequate data to support the stated expiry dating of a product and a continual program to assure product batch reproducibility; *rotation of stock* to assure that the oldest raw material lot is used first or the oldest product batch is shipped first; and *product sampling* to assure that samples of the correct number and size are withdrawn from the appropriate number of containers with proper microbiological control.

The SOPs described have by no means mentioned all those required in a manufacturing plant. They do, however, satisfy basic requirements and should provide insight so that areas in the specific organization for which SOPs are needed can be identified. It should always be remembered that more than one individual must be capable of performing a given task; at times he or she will be on vacation or absent because of sickness. In addition, an individual should not be relied on to perform tasks from memory, as there is no guarantee that such operations will be performed as reproducibly as may be required. Certainly no two individuals performing an operation from memory will do it identically. Written SOPs are necessary to avoid these pitfalls. Also, a written record provides a history that can be read and

studied if, for example, a product batch should fail and we seek to identify the cause.

2. *Specifications*, the second set of records, are parameters that describe the characteristics of a particular material. Each parameter has an acceptable range that is measurable using a given test procedure. For example, a raw material may be purchased as a free-flowing powder. There may be a specification for water content that requires that when a sample of raw material is analyzed using a given test procedure the water content cannot be more than 1.0%. If the assay exceeds this specified limit, the raw material lot is to be rejected. Sometimes a specification stipulates a minimum level, such as an assay of no less than 97.0%. At other times, a specification may indicate a range such as a pH of 6.5 to 7.5. Specifications must be written for each raw material, packaging component, in-process material, and finished product. They provide a yardstick by which we can analyze a material and evaluate whether it is desirable or undesirable. In the case of a component lot (raw material or packaging component), specifications enable us to judge whether or not we should use the lot to prepare a product batch. They provide a basis for comparison to previous lots received. The specifications for in-process material or finished product are a yardstick that enables us to determine whether or not the batch was manufactured properly.

Several officially recognized compendia describe specifications for components and finished product (e.g., U.S. Pharmacopeia, Food Chemicals Codex, British Pharmacopeia, and European Pharmacopeia). These specifications have been established by an advisory board to each compendium and represent the views of many manufacturers and government based on a history of the component or product. Such specifications are reviewed and updated as the need arises when new information becomes available. These compendia are very useful and should always be used as a guide whenever possible. In the case of the USP, for example, if a monograph exists for a component or product, U.S. drug manufacturers are required to satisfy those specifications as a minimum requirement.

Sometimes compendia do not contain a monograph for the specific item that we are interested in. We can use the compendia as guides, following the specifications established for similar items. Then we must use our judgment to establish parameters that the material should be tested for based on our knowledge of the chemistry of the material. The next step is methods development, to derive a test procedure that enables us to measure each parameter. By testing different lots of the material we can establish a specification for the parameter. This work

can be done in-house if your organization has the technical expertise and instrumentation that is needed. If not, outside consultant firms are available to assist.

Specifications have been established for several pharmaceutical ingredients. Figure 8 shows prototype specifications for an API that is commercially available as a solid and listed in the USP. Figure 9 shows an example of a liquid pharmaceutical excipient whose non-compendial specifications were developed by the supplier.

According to the International Conference on Harmonisation (*Federal Register* 65(25) 83041 (Dec. 29, 2000 notices)) specifications for APIs should cover the following categories:

- a. Description (state and appearance of the substance)
- b. Identification, such as spectrophotometry, chromatography, colorimetry, or optical activity
- c. A specific stability indicating assay method for testing purposes
- d. Impurity profile, including both organic and inorganic substances

Specifications are important in validating both raw materials and processes. They must be written and followed, unless there is just cause to change them. Specifications are normally used to screen out inferior and unacceptable materials. Sometimes the defect can't be identified because it was not considered initially in the original specifications. It is extremely important to understand the chemistry of the pharmaceutical ingredients that are used and to devote careful attention to setting specifications for them. Revision and upgrading of specifications may be required, but should be done in a thoughtful manner.

3. *Test procedures* are written procedures that provide the step-by-step details of how to perform the tests indicated in specifications or SOPs. They indicate the reagents to be used, sources of the chemicals, how the reagents are to be prepared, and the shelf life of the reagents. Also described are the apparatus to be used and special handling and precautions to be followed. At times a compendial test procedure is not in sufficient detail for a laboratory technician to follow exactly. In such a case, the procedure should be written in the necessary detail. A laboratory technician should not run a test without having the proper written procedure.
4. *Batch records* are listings of raw materials, by name and quantitative (weight or volume) measure, of a unit measure of finished product. Most manufacturers assign a code number to each raw material to provide a shorter way to refer to the raw material in batch records and labels, especially if such systems are computerized. The system consists of two separate records—a *master instruction sheet* and a

XYZ CORPORATION

API SPECIFICATION

---

MATERIAL: ACETAMINOPHEN	DATE APPROVED: 10-20-80
	PAGE 1 OF 1

---

TEST	SPECIFICATION	TEST METHOD
DESCRIPTION:	White, odorless, crystalline powder with a slightly bitter taste, soluble in boiling water and in alcohol.	XYZ
IDENTIFICATION:	A - IR absorption compared to USP RS. B - UV absorption compared to USP RS. C - Positive for violet blue color.	USP USP USP
MELTING RANGE:	168° - 172° C	USP
pH:	5.1 - 6.5	USP
WATER (METHOD I):	NMT 0.5%	USP
RESIDUE ON IGNITION:	NMT 0.1%	USP
CHLORIDE:	NMT 0.014%	USP
SULFATE:	NMT 0.02%	USP
SULFIDE:	No coloration or spotting of the test paper.	USP
HEAVY METALS (METHOD II):	NMT 0.001%	USP
READILY CARBONIZABLE SUBSTANCES:	NMT matching fluid A	USP
FREE p-AMINOPHENOL:	NMT 0.005%	USP
p-CHLOROACETANILIDE:	NMT 0.001%	USP
ASSAY (DRY BASIS):	98.0 - 101.0%	USP
TOTAL AEROBIC MICROBIAL COUNT:	NMT 1000/g	XYZ TEST PROCEDURE 16
MOLD AND YEAST COUNT:	NMT 500/g	XYZ TEST PROCEDURE 09
E. COLI:	Negative	XYZ TEST PROCEDURE 03

---

ACCEPTABLE CONTAINERS: FIBER DRUM WITH PE LINER  
APPROVAL EXPIRATION DATE: 1 YEAR  
APPROVED SUPPLIERS: AB CHEMICAL CO., ST CORP.  
REFERENCES: USP XX, pp. 11-12; XYZ CORP.

---

ISSUED BY:	APPROVED BY:
MB	EM
LC	LS

---

Figure 8 API specifications for acetaminophen.



XYZ CORPORATION  
EXCIPIENT SPECIFICATION

MATERIAL: LINSEED OIL

DATE APPROVED: 9-14-79  
PAGE 1 OF 1

<u>TEST</u>	<u>SPECIFICATIONS</u>	<u>TEST METHOD</u>
DESCRIPTION:	Yellowish liquid with characteristic odor and bland taste.	XYZ
SAPONIFICATION NO.:	187 - 195	USP
UNSAPONIFIABLE MATTER:	NMT 1.5%	USP
IODINE VALUE:	NLT 170	USP
SOLUBILITY:	Slightly soluble in alcohol; miscible with ether, petroleum ether, chloroform or carbon disulfide.	USP
TOTAL AEROBIC PLATE COUNT:	NMT 1000/g	XYZ PROCEDURE 16
MOLD AND YEAST COUNT:	NMT 500/g	XYZ PROCEDURE 09
E. COLI:	Negative	XYZ PROCEDURE 03
SALMONELLA:	Negative	XYZ PROCEDURE 88

ACCEPTABLE CONTAINER: STAINLESS STEEL DRUMS

APPROVAL EXPIRATION DATE: SIX MONTHS

APPROVED SUPPLIERS: NB CHEMICAL CO., TTL INC.

REFERENCES: USP XX ; XYZ CORP.

OTHER NAMES: FLAXSEED

ISSUED BY:  
RT  
CL

APPROVED BY:  
EM  
LS

Figure 9 Excipient specifications for linseed oil.

*data sheet* that is used to record various operating parameters. For the purpose of GMP compliance, the data reported should be accurate and be able to meet the requirements of a validated *master batch record*.

The following elements should be included in a typical API *master batch record*:

- a. Identification of critical processing steps
  - b. Batch revision number and date
  - c. Additional data sheets (not part of the approved *master batch record*)
  - d. Step-by-step production and control instructions, acceptable operating ranges and conditions, in-process specifications, and precautions to be followed
  - e. In-process sampling requirements
  - f. Justified limits or holding times for specific unit operations and the final product
  - g. Lot definition and final blend procedures
  - h. Yield calculation at appropriate steps in the process comparing actual vs. theoretical yield
5. *Manufacturing instructions* are the written procedures that personnel follow during actual product batch preparation. The instructions must document the modular equipment and materials to be used as well as the unit operations to be performed. (See [Figs. 3 and 4.](#)) The master document should also include step-by-step manufacturing instructions as well as GMP-required elements previously listed under the section on batch records.
6. *The approval process* is the last and most important part of record-keeping. All documents must be approved before they are used. If they require a change, the documents must again be approved before the change is implemented. One type of problem discussed earlier identifies the need for and importance of written records. Now we must focus our attention on the dilemma created if the records are wrong or if they become obsolete. Once a document has been approved and issued, it is the responsibility of the respective personnel to use it and follow it. No change should ever be permitted without observing an established approval procedure, because that defeats the purpose for the document in the first place. If a procedure is to be changed, several designated individuals should be aware of the need for change. It does no good if one person changes a procedure and the others who use it (or those who approved it) are not made aware of the change.

A manufacturer must establish a list of approvals required for its records, a list that is not unmanageable yet provides adequate assur-

ance that a signed document is meaningful. Theoretically, at least two signatures are required on such documents—one representing production and one quality control. Generally there is also another signature, that of the one who either wrote the procedure or initiated the change. A manufacturing organization must designate a list of individuals appropriate to its own operation; however, it is important to remember that changing an established procedure indiscriminately in the midst of a serious product problem without bringing the matter to the attention of the proper individuals may do more harm than good. Effecting a short-range solution with no thought of the long-range effect can be damaging.

## V. DRUG MASTER FILE

A *drug master file* (DMF) is defined as a reference source providing detailed information about a specific facility, process, or article used in the manufacture, processing, packing, or holding of a (drug) substance that is the subject of an investigational new drug application (IND), a new drug application (NDA), an abbreviated new drug application (ANDA), or antibiotic form 6 or 7. Drug master files originated in 1943 with the submission of information of a chemical substance to support a drug product application, apparently to ensure confidentiality of the chemical process for making the chemical substance.

The basic requirements for a type II DMF submission for an API, a drug substance intermediate, and any material used in the preparation of a drug product consists of the following elements:

- Disclosure of the company and its operations
- Description of the facilities and equipment used in the manufacturing process
- Description of the sanitation systems on the premises for cleaning and disposal
- Organization, qualifications, and training of personnel
- Description of raw materials and packaging components, including specifications, procedures, and control documentation
- Description of quality control and testing procedures
- Description of sterile products manufacture and control, if applicable
- Description of the quality assurance program
- Stability program documentation
- Environmental impact assessment statement
- Notification of changes or amendments to the DMF
- Letter of authorization to make reference to the DMF

Statement of commitment to comply with the information contained within the DMF

The past resistance to the validation of APIs is that much of the required information and documentation should be contained within the scope and requirements of a successfully completed DMF. A DMF document, however, does not have the legal weight of the CGMP regulations, which provide the basis for requiring API validation documentation.

## VI. CHIRAL APIs

According to the FDA guideline for marketing chiral drugs (APIs) issued in May 1995, drug companies have the choice of developing chiral drugs as *racemates* (50% mixture of the D and L forms or *enantiomers*) or as individual single enantiomers. Enantiomers have opposite rotational optical activity in solution. Most companies today have decided to move toward the development of pharmaceutically active single enantiomers. If the racemate had been approved alone or in a pharmaceutical dosage form, the development program for the single active enantiomer can be shortened.

Certain chiral APIs, however, are *diastereoisomers* and mesocompounds with two or more optically active centers (carbons) in the molecule (i.e., erythrose, threose, and mesotartaric acid). In such cases, simplification between racemates and single enantiomers is often not readily apparent. The conversion of racemates to active enantiomers can be accomplished using one of the following reaction pathways:

- Lipase immobilized hollow-fiber membranes
- Asymmetric dihydroxylation
- Asymmetric epoxidation
- Fermentation methods for synthesis and resolution
- Reaction with cyclic lactam intermediates
- Reaction with glycine and aldolase
- Fractional crystallization

The advantage of the active enantiomer is that in most cases its activity is twice that of the racemate and its toxicity potential is one-half. The potency stability of the active API enantiomer both in the solid state and in solution is an important concern to be addressed during process validation.

## VII. STABILITY OF PHARMACEUTICAL INGREDIENTS

A formal testing program should be established in order to determine the stability characteristics of APIs. Similar but less stringent stability testing procedures

can be set up for pharmaceutical excipients as well. The results of such testing are used to determine appropriate storage conditions and expiry dating requirements. The testing program should include sufficient batches, sample sizes, and testing intervals, plus appropriate storage conditions and a stability indicating test method in order to obtain relevant stability data for pharmaceutical ingredients per se.

When pharmaceutical ingredients (both active and excipient) are made part of a pharmaceutical dosage, they are now components of a separate drug product stability program.

The testing requirements for pharmaceutical ingredients are similar to those for drug products.

*Stress testing* is used to determine the intrinsic physical and chemical stability of the pharmaceutical ingredient under accelerated, elevated temperature storage conditions, such as 50°C- 75% RH, 40°C- 75% RH, and 30°C- 60% RH.

Testing frequencies under accelerated storage conditions are usually 0-, 1-, 3-, and 6-month intervals or longer-term stability testing every 3 months during the first year and semiannually thereafter at ambient temperature conditions.

For substances intended for refrigerated or freezer storage: 25°C-60%RH and 5°C and -15°C at ambient relative humidity (RH) are used.

In the case of photostability testing the pharmaceutical ingredient may be subjected to xenon, metal halide, near UV, or cool white fluorescent lamp exposure.

Typical testing for stability studies includes appearance, potency, chiral assay, and related substances (impurities, degradation products, and contaminants) by HPLC assay, water content by Karl Fischer, identification by NIR or NMR, melting point by DSC, plus microbial testing.

Stress testing is used to help identify degradation pathways under the influence of accelerated heat, light, and RH conditions in the presence or absence of air or oxygen. Such stability testing protocols represent an important aspect of a pharmaceutical ingredient process validation program.

## VIII. REPROCESSING

According to the ICH guidance document, introducing an intermediate (key or final) or API that does not conform to standards or specifications back into the process by repeating a crystallization step or other physical manipulation (i.e., distillation, filtration, chromatography, milling, and drying) that is part of the

established manufacturing process is generally considered to be acceptable. If reprocessing is used quite often, however, the procedure should be made part of the manufacturing SOP.

Continuing a processing step that in-process control testing indicates to be an incomplete step is not considered to be reprocessing. Introducing unreactive material back into a process and repeating a chemical reaction, however, is considered to be reprocessing, unless the procedure(s) was (were) made part of the original manufacturing SOP.

In any case, careful evaluation to ensure that the quality of the intermediate (key or final) or API is not adversely affected through the formation of additional by-products and impurities is extremely important. Before a decision is made to rework or reprocess batches that do not conform to established standards or specifications, an investigation into the reason for nonconformance should be carried out. Such procedures should provide impurity profile data for each reworked or reprocessed batch to be compared to comparable data for routine manufactured batches. Reprocessing (recycling) means repeating existing procedures, while reworking is taken to mean making modifications to existing procedures.

Recovery of reactants, intermediates, or APIs from mother liquors or filtrates is acceptable as long as the procedures used meet in-process product/process specifications. Solvents can be recovered and reused as long as the procedures employed are adequately documented.

## IX. RETROSPECTIVE VALIDATION

Retrospective validation of APIs consists of a review and analysis using statistical process control methods, the physical process parameters, and analytical test data for immediate past batches (at least the last consecutive lots), and should include numerical data for starting materials, intermediates (key and final), and the finished API. *Impurity profiles* are an important part of such historic data. The purpose of retrospective validation is to show, through such supporting documentation process control and reproducibility for intermediates and the finished API itself. If the data of retrospective validation purposes are faulty, the regulatory authority expects the manufacturer to conduct appropriate *prospective or concurrent* validation studies in accordance with a pre-established, adequate testing plan or *protocol*. Such a plan or protocol should identify process equipment, critical process parameters and their operating ranges, critical characteristics of the API, sampling plan, and test data to be collected for at least *three consecutive* designated batches to demonstrate the consistency of the overall manufacturing process for the API. In addition, such plans or protocol should define what constitutes acceptable results.

## X. REVALIDATION

The revalidation of an API process may be initiated at periodic intervals (annually) or whenever *significant* changes are made to equipment, systems, or processes. The revalidation effort will depend on the nature and extent of the changes made. The evaluation and decisions regarding the need for revalidation should be documented. Any indication of failure should result in an investigation to identify the cause and to take necessary corrective action. An assessment should be made regarding the need for additional formal process validation. In the absence of changes or process failure, an *annual review* of data covering manufactured lots should be made to assess the need for more formal revalidation studies.

## XI. CHANGE CONTROL

Process validation of an API should include an SOP to reassess a process whenever there are significant changes in the process, equipment, facilities, reactants, process materials, systems, and so on that may affect the *critical* quality attributes and specifications of the API. Such changes should be documented and approved in accordance with the scope of the change control SOP. The change control SOP should consist of the following elements:

- Documentation that describes the procedure, review, approval, and basis for formal revalidation studies
- Identification of the change and assessment of its likely implication
- Requirements for monitoring change and testing needs
- Assessment of information and justification for the change
- Review and formal approval to proceed
- Identification of changes made to the physical and chemical composition of the API
- Possible regulatory action and customer notification

## XII. BULK ACTIVES POSTAPPROVAL CHANGES

The FDA recently issued a guidance document concerning bulk actives post-approval changes (BACPACS), *BACPAC I: Chemistry, Manufacturing and Controls Documentation*, which essentially covers key and final intermediates in API synthesis (U.S. FDA, CDER, and CVM, issued Feb. 2001). Changes may be made through one of the following reporting categories:

Prior approval supplement (PAS)  
Supplement—change being effected (CBE)  
Annual report (AR)

The guidance document addresses postapproval changes with respect to semisynthetic drug substances and impurities associated with APIs. The guidance document covers changes associated with the following:

Site  
Scale of the synthetic processes involved  
Equipment used in processes  
Specifications for raw materials, including final intermediates  
Manufacturing process changes involving synthetic steps through the final intermediates

Changes to the final intermediates and the resulting API will be covered in the BACPAC II guidance document. Postapproval changes affecting peptides, oligonucleotides, radiopharmaceuticals, natural materials, and semisynthetic APIs are not covered by BACPAC at the present time.

*Site changes* within a single facility where the synthetic pathway remains unchanged and CGMP procedures are followed need not be filed with the FDA. They are considered to be AR changes. If the site change involves the final intermediate, it is considered to be a CBE-type change. If the site is under new ownership and not listed in the approved NDA, it also requires a CBE-type change.

*Scale changes* either increase or decrease in batch size and are considered to be AR changes as long as the data output is comparable to the original batch size.

*Specific changes* related to a new analytical method that provides equal or greater assurances of quality is also considered to be an AR change.

*Manufacturing process changes* are those that encompass a wide range of process-related changes, from the use of different equipment to changes in synthetic components and procedures. Such changes are considered to be CBE-type changes.

*Multiple changes* in site, scale, and manufacturing processes are considered to be PAS-type changes and require prior approval from the FDA. More detailed information is provided in the current FDA guidance documents. (See the Bibliography.)

### **XIII. OUTSOURCING AND CONTRACT MANUFACTURE**

With respect to the pharmaceutical industry, outsourcing and contract manufacture probably got its start with APIs, final and key intermediates, and other steps



in the synthetic process because of the complexity of API manufacture. The advantages and disadvantages of outsourcing and contract manufacture are presented as follows:

#### Advantages

- Less expensive to purchase
- Access to specialized and new technologies not currently available in-plant
- Availability from known suppliers with more chemical manufacturing experience

#### Disadvantages

- Receive delays without proper internal control on the part of the supplier
- Requires a commitment on the part of the purchaser to an external audit for GMP and/or ISO 9000 compliance
- Requires more internal quality control on the part of the purchaser beyond certificate of analysis acceptance

Auditing the contract API manufacturer is important in order to assess the quality systems used to determine the integrity and quality capability of the firm, to determine their level of GMP compliance, and assess the level of resources available to meet preapproval inspections (PAI) and GMP compliance readiness.

Typical agenda items for discussion with a potential contract API manufacturer should include the following:

- Organizational structure, site history, and review of previous FDA inspections
- Overview of the firm's key technologies, core competencies, and managerial capabilities
- Overview of the site's facilities, equipment, and potential production capacity
- Overview of the firm's chemical development and analytical testing capabilities
- Overview of the firm's quality assurance and documentation systems
- The firm's proposed plans and time schedule to meet your company's objectives and requirements

Do not oppose outsourcing and contract manufacturing strategies. Point out to corporate management, however, that the ultimate responsibility for API manufacture rests with the internal operational functions of your company and not with those of the vendor or supplier.

**Table 5** Qualification/Validation of Pharmaceutical Ingredients

---

Process definition

Options: synthesis/fermentation/extraction/purification

Facilities and equipment (unit operations)

IQ (design and installation)

OQ (operating ranges)

PQ (attributes/specs)

Cleaning validation program

Manufacturing SOP and control parameters

Process flowchart and description of chemistry

Personnel training and safety considerations

Quality attributes

Assay and yield

Impurity profile (qualitative and quantitative)

Contaminant profile (qualitative and quantitative)

Physical characteristics of active API (aspect, thermal analysis, particle size distribution, optical activity, polymorphic forms, moisture content, loss on drying, microbial content, etc.)

Analytical methods validation

Critical operating parameters

Reactant ratios, reaction time, temperature, pressure, O<sub>2</sub>/CO<sub>2</sub> ratios, pH (amount of acid or base), impurity concentration, etc.

Ranges for critical operating parameters

Worst-case challenges during pilot laboratory scale-up for yield, stability, and impurities

Control of process components

Raw materials, solvents, catalysts, gases, processing aids, processing water, steam, packaging materials and bioburden

Process validation protocol

Sampling and testing strategy

What constitutes acceptable in-process and final product

Formal process validation

At least three batches for reproducibility

Change control procedures and conditions for revalidation, reprocessing, and recovery validation documentation

Include all pertinent data and reports from design, qualification, and validation stages

---

## XIV. CLEANING VALIDATION

Based upon ICH guidelines, cleaning procedures should be validated. Cleaning validation should be directed toward processing steps in which possible contamination or material carryover poses a risk to API quality. If residues are removed by subsequent purification steps in the process, cleaning procedures can be less rigorous.

*Cleaning validation protocols* should describe the equipment to be cleaned, procedures, materials, acceptance criteria, parameters to be monitored and controlled, and the analytical methods to be employed for testing. Validation of cleaning procedures should reflect equipment to be used for key and final intermediates and APIs. The selection of cleaning procedures to be employed should be based on material solubility and cleaning difficulty. The calculation of residue limits should consider the potency, toxicity, and stability of critical materials.

Validated analytical methods should have sufficient sensitivity to detect residues or contaminants. Residue limits should be practical, achievable, verifiable, and based upon the most deleterious residue. All cleaning procedures should be monitored at appropriate intervals to ensure that these procedures are effective during routine production.

## XV. QUALIFICATION/VALIDATION OF PHARMACEUTICAL INGREDIENTS

A summary of the critical aspects of the process validation of pharmaceutical ingredients is presented in [Table 5](#).

## BIBLIOGRAPHY

- Avallone, H. L. GMP inspection of drug substance manufacturers. *Pharm Tech* (June 1992).
- Berry, I. R., Harpaz, D. *Validation of Active Pharmaceutical Ingredients*. 2nd ed. Denver: IHS Health Group (2001).
- Fabian, A. C. Global harmonisation of GMPs for APIs. *Pharm Tech* (June 1999).
- FDA/ISPE. *Baseline Pharm. Eng. Guide*. Vol. 1, BPCs (June 1996).
- FDA (CDER). *Guidance for Industry, ANDAs: Impurities in Drug Substances* (June 1998).
- FDA (CDER). *Guidance for Industry, BACPAC I: Intermediates in APIs* (Feb. 2001).
- FDA (CDER). *Guidance for Industry: Manufacturing, Processing & Holding of APIs* (March 1998).
- Fry, E. M. FDA perspective on BPCs. *Pharm Tech* (Feb. 1984).

Gold, D. H. GMP issues in API manufacture. *Pharm Tech* (April 1992).

Goode, S. A. IPEC GMP audit guideline for BPCs. *Pharm Tech* (Aug. 1999).

*Handbook of Pharm. Excipients*. 3rd ed. APhA & London Pharmaceutical Press (2000).

Hirschorn, J. O., Flanigan, T. Global GMP regulations for BPC facilities. *J cGMP Comp* 4(4), (July 2000).

International Conference on Harmonisation (ICH). *GMP Guide for APIs* (Nov. 2000).

International Conference on Harmonisation (ICH). *Guidance for Industry: Photostability Testing of Drug Substances* (Nov. 1996).

International Pharmaceutical Excipients Council (IPEC). *GMPs for Excipients* (1995).

Martinez, Rivera, E. FDA perspective on BPC GMPs. *Pharm Eng* (May/June 1994).

Pharm. Inspection Convention (PIC). *GMP Guidelines for APIs Manufacturers* (July 1997).

Tuthill, S. M. BPCs GMP. *Pharm Tech* (Feb. 1979).

Wintner, B. Environmental controls in the pharm. Industry. *Pharm Eng* (April 1993).

Yu, L. W. Selecting a contract API Co. *Amer Pharm Outsourcing*, (July/Aug. 2001).

# 12

## Qualification of Water and Air Handling Systems

**Kunio Kawamura**

*Otsuka Pharmaceutical Co., Ltd., Tokushima, Japan*

### I. PURPOSE OF VALIDATION

High-quality water and air are essential for the manufacture of pharmaceuticals. Water is the most commonly used raw material in pharmaceutical manufacturing; it is indirectly used in the manufacture of all dosage forms for cleaning manufacturing equipment, and is also used as a major component which constitutes injectable products. It is the one raw material that is usually processed by the pharmaceutical manufacturer prior to use because it cannot be used as supplied by the vendor. Water should be regarded as one of major raw materials for the manufacture of pharmaceuticals whether or not it remains as a component of the finished dosage form or is eliminated during the manufacturing process. Water is thus an important raw material in GMP and in validating the manufacturing process.

Air supplied to the pharmaceutical manufacturing area or the air in the environment of the pharmaceutical manufacturing area always contacts with pharmaceuticals, and the quality of air influences the quality of the pharmaceuticals manufactured, particularly in their cleanliness, particulates, and microbial quality. Temperature and humidity in the manufacturing environment also influence the quality of the pharmaceuticals manufactured.

The importance of air quality and air handling system are described in CFR 211-46 as part of GMP.

The USP identifies several grades of water that are acceptable for use in pharmaceuticals, and also defines the quality of the environment or the quality of air for the manufacturing of pharmaceuticals according to its criticality.

Water and the environment must be periodically monitored for these quality attributes, and in some instances the results are not available for days after the sample is obtained. Meanwhile, the water would have been used to manufacture a great number of pharmaceutical products or else the products would have already been exposed to the environment. Water treatment and air handling systems are highly dynamic, and careful attention has to be paid to their operation, even though this may sometimes be somewhat unreliable. Consequently, they must be validated and then closely monitored and controlled.

Validation is defined as “a documented program that provides a high degree of assurance that a specific process, method, or system will consistently produce a result meeting pre-determined acceptance criteria” [1].

The purpose of validation is to demonstrate the capability of the water treatment and air handling system to continuously supply the required quantity of water and air with the specified quality attributes. “Documented” means to provide documented “evidence.” Validation provides the system owner with the means of assessing when a water treatment and/or air handling system is operating outside established control parameter limits and provides a means for bringing the system back into a state of control. It results in written operating and maintenance procedures for personnel to follow, which in turn helps ensure consistent system performance.

## **II. VALIDATION STRATEGY**

### **A. Validation Concept**

The basic strategy is to prove the performance of processes or systems under all conditions expected to be encountered during future operations. To prove the performance, one must demonstrate (document) that the processes or systems consistently produce the specified quantity and quality of water and/or air when operated and maintained according to specific written operating and maintenance procedures. In other words, validation involves proving

1. Engineering design
2. Operating procedures and acceptable ranges for control parameters
3. Maintenance procedures

To accomplish this, the system must be carefully designed, installed, and tested during and after construction, and therefore for a prolonged period of time under all operating conditions.

Variations in daily, weekly, and annual system usage patterns must be validated. For example, water may be drawn from the system for manufacturing use only during normal working hours; there may be no demands on the system at other times during the 24-hr cycle. The system may be idle on weekends and

on holidays, which could extend for as long as 4 days or more. In addition, *many* firms have annual plant maintenance shutdowns, typically in the summer, and systems must be sanitized and restarted prior to use, and of course emergency shutdowns can occur at any time and the system must be brought back online. Systems with ion exchange resins (deionizers) must be at least partially shut down to regenerate the resins when the chemical quality of the treated water drops below a specified level. (This could be a matter of a few days or even a few months, depending on the quantity of water processed through the system and other factors.) For the air handling system, the same kinds of issues exist. Clean rooms should be maintained at their required cleanliness level, even during the time of no manufacturing operation. If the cleanliness is broken or the air handling system stops, the whole clean area has to be made clean according to the initial validation procedure and assessment. Water treatment and/or air handling systems must be validated under all of these normal operating conditions in order to prove the adequacy of the engineering design and the effectiveness of the operating, control, and maintenance procedures.

## **B. Validation Life Cycle**

### **1. Determination of Quality Attributes**

In performing the validation, defining the quality attributes—that is, gaining a clear understanding of the required quality and intended use—is the most important issue, and should be determined before starting the validation. Without defining required quality attributes we cannot establish validation protocols, which are the basis of all validation studies.

### **2. The Validation Protocol**

A validation protocol is defined as

A written plan stating how validation will be conducted and defining acceptance criteria. For example, the protocol for a manufacturing process identifies process equipment, critical process parameters/operation ranges, product characteristics, sampling, and test data to be collected, number of validation runs, and acceptable test results [1].

The validation protocol is a detailed plan for conducting a validation study. It is drafted by the individual or task group responsible for the project, reviewed for content and completeness following the firm's protocol review procedure, and approved by designated individuals. It describes the responsibilities of *each* individual or unit involved in the project.

All protocols, whether for IQ (installation qualification)/OQ (operational qualification) of new equipment or for validating a new process, have the same

basic format. They start with an *objective* section, which describes the reasons for conducting the validation study as well as the results to be achieved. Next there is a *scope* section. Here what is to be included and excluded from the study is specified, effectively establishing the boundaries for the study.

Following the *objective* and *scope* sections is a *detailed description of the process/equipment* to be validated. Here block diagrams of equipment, batch formula and master manufacturing records, process flow diagrams, and other documents that will help with the descriptive process are essential and should be attached to the protocol. The protocol should contain a detailed description of the sampling and testing schedule and procedures and clearly state the acceptance criteria for each stage of validation, such as DQ (design qualification), IQ, OQ, and PQ (performance qualification). The number of times that specific trials will be replaced in order to demonstrate reproducibility of results must be specified.

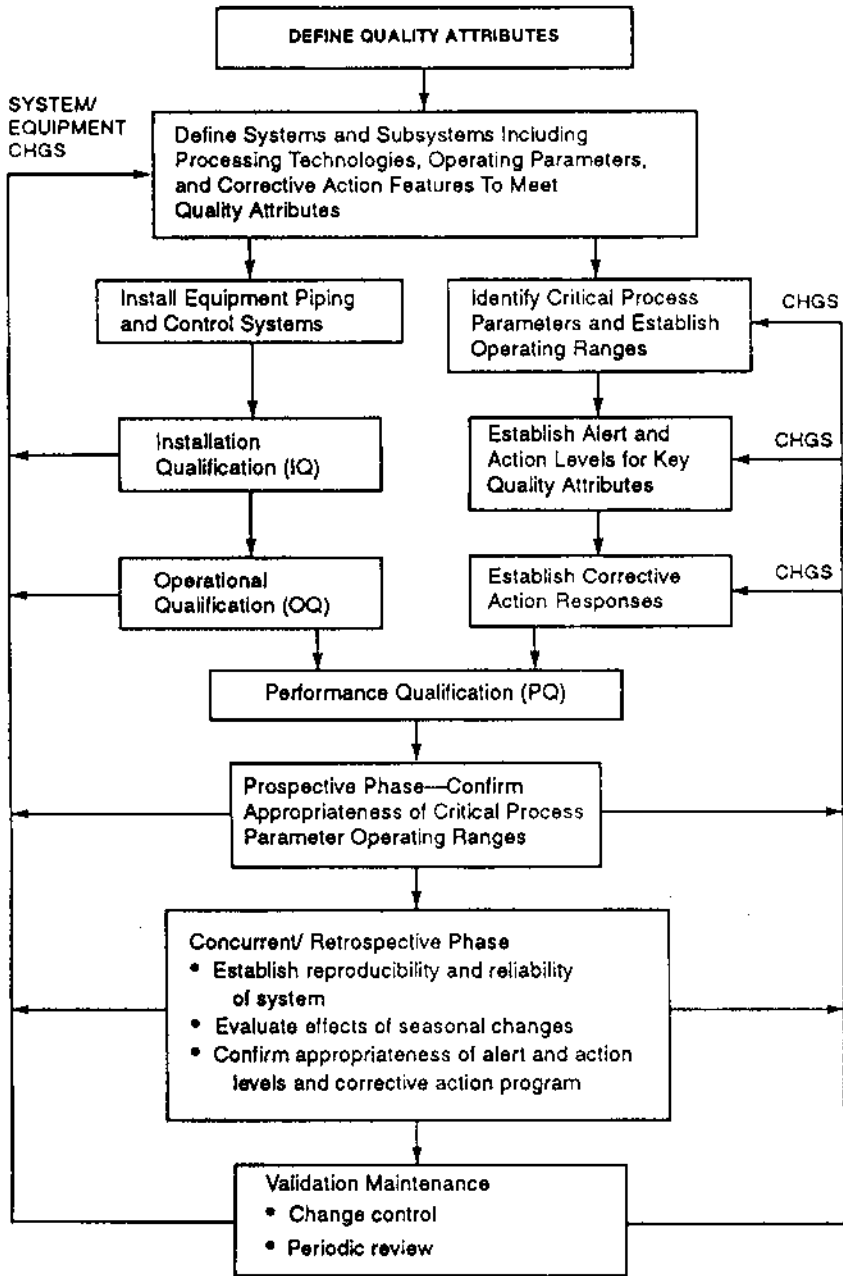
The protocol should be endorsed by designated representatives of each unit that will participate in the validation study. This is an essential step for validation study. It should be described that the protocol is accepted by responsible persons, and that each unit understands and agrees to fulfill its responsibilities as stated in the protocol. Subsequent changes to the protocol, should they be necessary, must be endorsed by the same individuals. Protocol addenda are sometimes necessary because circumstances later arise that were impossible to anticipate when the study was planned and the protocol drafted. In addition to approvals, the validation protocol should have the appended data sheets, which are to be filled with data obtained from the validation studies and compared with the criteria.

### 3. Steps of Validation

Validation plans for water and air systems typically include the following steps (Fig. 1):

1. Establishing standards for quality attributes of water and air to manufacture pharmaceuticals.
2. Defining systems and subsystems suitable to produce the desired water and air by considering the quality grades of water and air.
3. Designing equipment, controls, and monitoring technologies.
4. Establishing standards for operating parameters of the selected equipment of the system.
5. Developing an IQ stage consisting of instrument calibrations, inspections to verify that the drawings accurately depict the as-built configuration of the system, and special tests to verify that the installation meets the design requirements. These items include pipe and instrument drawings, air pressure differentials, air velocities, and airflow patterns.





**Figure 1** Validation life cycle of water and air system. (From Ref. 2.)

6. Developing an OQ stage consisting of tests and inspections to verify that the equipment, system alerts, and controls are operating.
7. Establishing alert and action levels for the operational standards and routine control. This phase of qualification may overlap with aspects of the next step.
8. Developing a prospective PQ stage to confirm the appropriateness of critical process parameter operating ranges. System reproducibility is to be demonstrated in this stage over an appropriate time period. During this phase of validation, alert and action levels for key quality attributes of water, such as TOC, pH, particulates and microbes, and operating parameters for an air system (e.g., temperature, time, air pressure differential, airflow velocity, and air exchange rate) are verified.
9. Supplementing a validation maintenance program (also called continuous validation life cycle) that includes a mechanism to control changes to the system and establishes and carries out scheduled preventive maintenance, including recalibration of instruments.
10. Instituting a schedule for periodic review of the system performance and requalification.
11. Completing protocols and documenting steps 1 through 10 [2].

#### 4. Control During Routine Operation

*Revalidation and Change Control.* Once the validation is completed, the standard operating procedures (SOPs) are formalized. Routine operation should be performed according to the established SOP.

Any proposed changes should be evaluated for their impact on the whole system. The necessity for requalifying the system because of changes should be determined. Revalidation and evaluation should be performed depending upon the impact that might be caused by the change.

*Alert and Action Levels.* Validated and established systems should be periodically monitored to confirm that they continue to operate within their design specifications and consistently produce water or air of acceptable quality. Monitored data may be compared to established process parameters or product specifications. A refinement to the use of process parameters and product specifications is the establishment of alert and action levels, which signal a shift in process performance. Alert and action levels are distinct from process parameters and product specifications in that they are used for monitoring and control rather than accept or reject decisions. The levels should be determined based on the statistical analysis of the data obtained by monitoring at the PQ step.

Alert levels are levels or ranges that when exceeded indicate that a process may have drifted from its normal operation condition. Alert levels indicate a

warning and do not necessarily require a corrective action. Exceeding an action level indicates that corrective action should be taken to bring the process back into its normal operating range [2,8].

### III. QUALIFICATION OF WATER SYSTEMS

#### A. Required Quality for Water for Pharmaceutical Purposes

Water is one of the most widely used substances, and raw materials, or an ingredient in the production, processing, and formulation of pharmaceuticals.

Control of the organic and inorganic impurities and microbiological quality of water is important because proliferation of micro-organisms ubiquitous in water may occur during the purification, storage, and distribution of this substance. Although there are various quality grades of water used for pharmaceutical purposes, all kinds of water are usually manufactured from drinking water or comparable grade water as a source water.

Grades of water are closely related to the manufacturing methods and distribution system of water. Major differences among these grades of water consist of the following quality attributes:

Microbial counts

Endotoxin, which is due to the presence of microbes

Organic and inorganic impurities

Grades of water specified in the compendia (USP) are classified according to the above quality attributes as

1. Potable water
2. Purified water
3. Water for injection
4. Sterile water for injection
5. Sterile water for inhalation
6. Sterile water for irrigation
7. Sterile bacteriostatic water for injection

Grades of water specified in the *Pharmacopeia* (USP) are summarized in [Table 1](#). “Water for injection” (WFI) is the most purified water, and careful attention should be paid to the validation of its manufacturing process.

#### B. Selection of Water for Pharmaceutical Purposes

The quality attributes of water for a particular application are dictated by the requirement of its usage. Sequential steps that are used for treating water for different pharmaceutical purposes are shown in [Figure 2](#) [6].

**Table 1** Specifications of Water for Pharmaceutical Use

	Inorganics	Microbial control	Microbial limit	Particulate matter	Endotoxin
Source water (I)	— <sup>a</sup>	— <sup>a</sup>	— <sup>a</sup>	— <sup>a</sup>	— <sup>a</sup>
City water (potable) (II)	Reg. <sup>b</sup>	Reg. <sup>b</sup>	Reg. <sup>b</sup>	— <sup>a</sup>	— <sup>a</sup>
Purified water (deionized) (III)	+ <sup>c</sup>	+ <sup>c</sup>	100 CFU/mL <sup>d</sup>	— <sup>a</sup>	— <sup>a</sup>
Purified water (membrane) (IV)	+ <sup>c</sup>	+ <sup>c</sup>	100 CFU/mL <sup>d</sup>	— <sup>a</sup>	+
WFI (rinse) (V)	+ <sup>c</sup>	+ <sup>c</sup>	100 CFU/mL <sup>d</sup>	— <sup>a</sup>	+
WFI (preparation) (VI)	+ <sup>c</sup>	+ <sup>c</sup>	100 CFU/mL <sup>d</sup>	+ <sup>f</sup>	<0.25 EU/ml <sup>e</sup>
WFI (LVP) (VII)	+ <sup>c</sup>	+ <sup>c</sup>	100 CFU/mL <sup>d</sup>	+ <sup>f</sup>	<0.25 EU/ml <sup>e</sup>

<sup>a</sup>No control, no specifications.

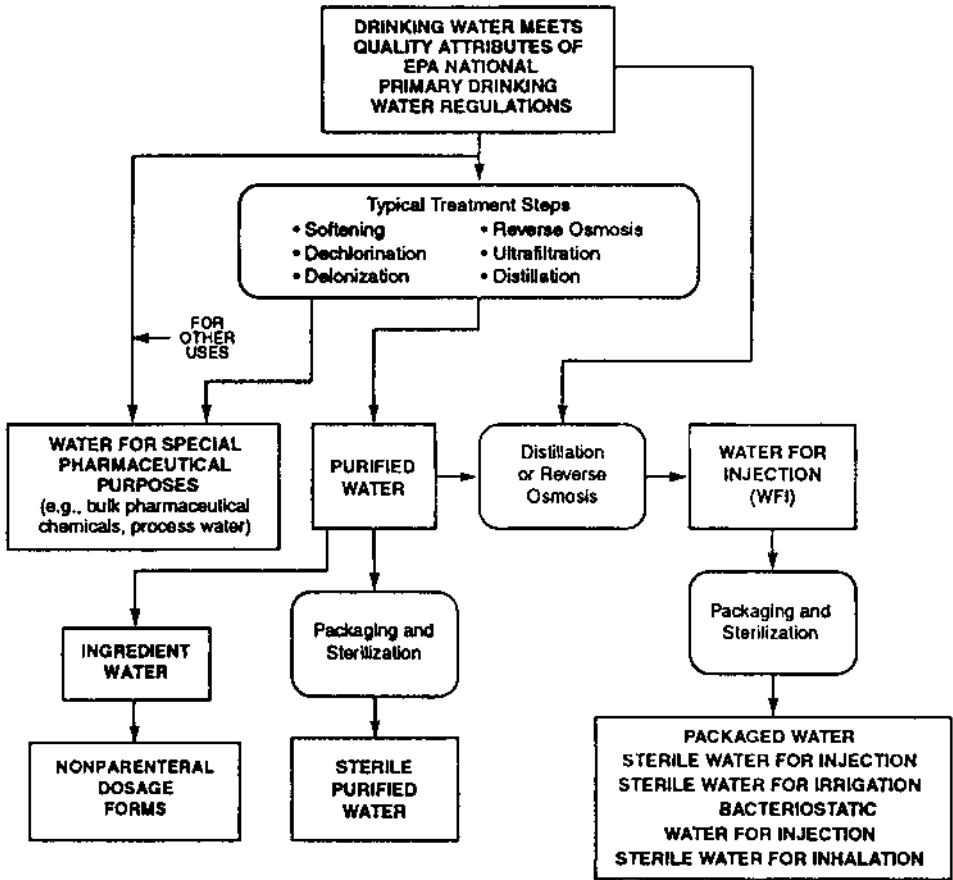
<sup>b</sup>City water regulations.

<sup>c</sup>Controlled to be less than city water specifications. Microbial counts in deionized water should be carefully controlled.

<sup>d</sup>According to the specifications by USP/EP, and recommended criteria final rinse water: 10 CFU/100 mL.

<sup>e</sup>Cooling water used for sterile products: 1 CFU/100 mL.

<sup>f</sup>Particulate matter for LVP: (>10 µm, 20/ml), >25 µm, 2/ml).



**Figure 2** Water for pharmaceutical purposes. (From Ref. 2.)

The manufacturing method and distribution system also have a close relation with the construction design of facilities and equipment.

1. Selection of the most suitable quality grade of water for its intended use.
2. Determination of the water manufacturing system elements, including facility and equipment.
3. Design of water manufacturing system, including the design of system equipment.
4. After construction of the water system is completed based on its design, the system has to be scrutinized as to whether it has been built to design specification or not.

5. After confirming the installation of facility and equipment, the quality of water produced is examined from various viewpoints according to the predetermined specifications.
6. In the routine production of water, representative quality items of water have to be monitored to confirm the performance of normal operation, and if any undesirable trends or out of specification values are found, corrective action should be taken.

The steps of checking design and construction, confirming proper installation and operation, and documenting these processes are collectively called qualification or validation. In case of any system change or changes to equipment, the same kinds of procedures should be implemented.

Water for pharmaceutical purposes, and selection of water grade for pharmaceuticals are summarized in [Figures 1](#) and [2](#). Specifications of various kinds of water are summarized in [Table 1](#).

Major items of quality attributes that should be controlled and specified for pharmaceutical use are

1. Organic impurities
2. Inorganic impurities
3. Particulates
4. Microbes
5. Endotoxin

### **C. Design Qualification of Water Systems**

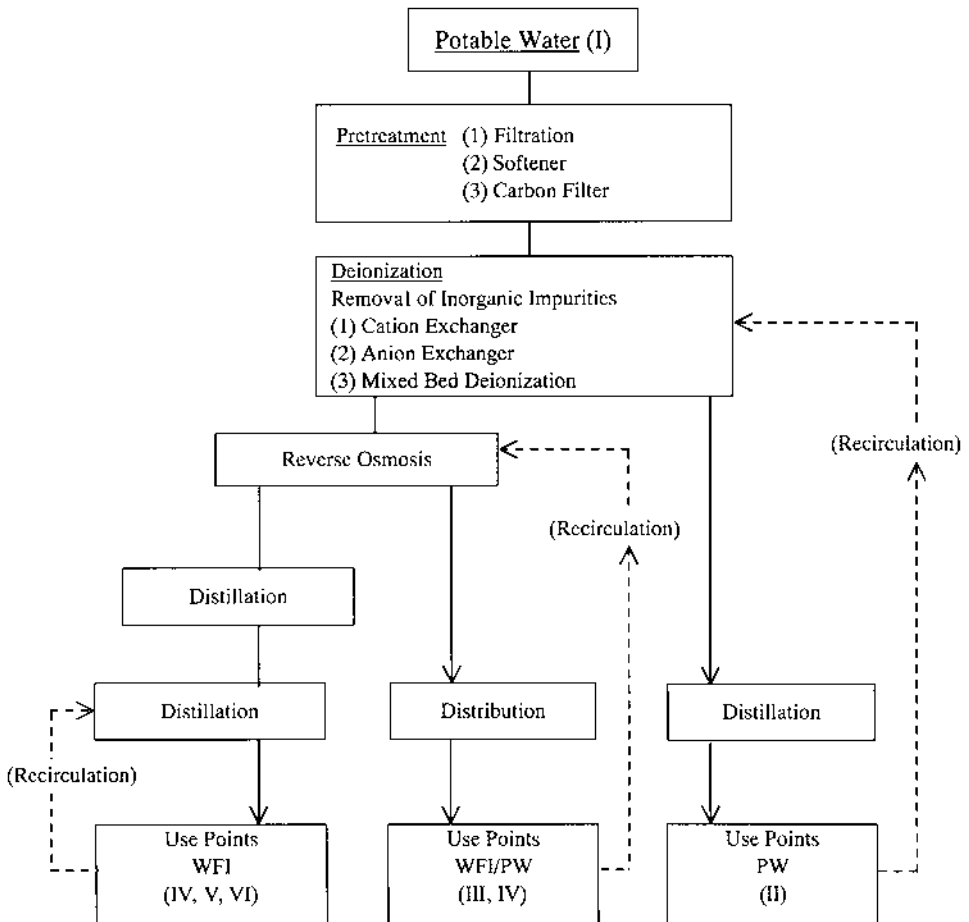
The quality attributes of water for a particular application are dictated by the requirements of its usage. Production of pharmaceutical water employs a combination of sequential unit operations (processing steps) that address specific water quality attributes.

The validation plan should be designed to establish the suitability of the system and provide a thorough understanding of the purification mechanism, range of operating conditions, required pretreatment, and the most likely mode of failure. It is also necessary to demonstrate the effectiveness of the monitoring scheme and to establish the requirements for validation maintenance. The selection of specific unit operations and design characteristics for a water system should take into consideration the quality of the feed water, the technology chosen for subsequent processing steps, the extent and complexity of the water distribution system, and the appropriate requirements. In a system for WFI, the final process (distillation, reverse osmosis, or ultrafiltration) must have effective bacterial endotoxin reduction capability and must be validated for each specific equipment unit. The final unit operations used to produce WFI have been limited to distillation, reverse osmosis, and/or ultrafiltration. Distillation has a long

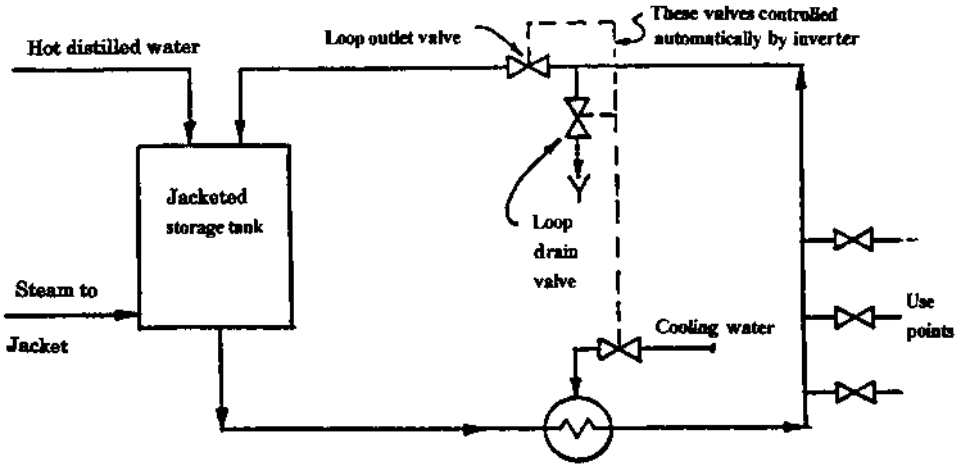
history of reliable performance for the production of WFI. Other technologies, such as reverse osmosis and ultrafiltration, may be suitable in the production of WFI if they are appropriately validated for each specific set of equipment.

Typical sequential processing steps that are used for manufacturing *purified water* (PW) are shown in Figure 3. A distilled water distribution system that is commonly used for *WFI* is shown in Figure 4.

1. Step 1 is the combination of prefilter, carbon filter, and ion exchanger (softener). After chlorine is removed, attention has to be paid to pre-



**Figure 3** Typical sequential processing steps for water treatment.



**Figure 4** Typical sequential processing steps for distilled water treatment. When cooling water is not needed, water will circulate at 80°C or above. During use the cooling water valve is open and the loop outlet valve is closed. After use the loop outlet valve is kept closed and the loop drain valve opened to flush all the cooled water to drain.

vent microbial growth. For this purpose, ultraviolet light is installed and the water is circulated.

2. Step 2 is a reverse osmosis process, after adjusting temperatures by heat exchanger.

After the reverse osmosis process, inorganic impurities are completely removed by anion exchanger and cation exchanger. An ultraviolet light is installed and the water is circulated to prevent microbial growth.

The obtained water can be used for nonparenteral dosage forms. For the parenteral purpose, water obtained in this way is usually distilled.

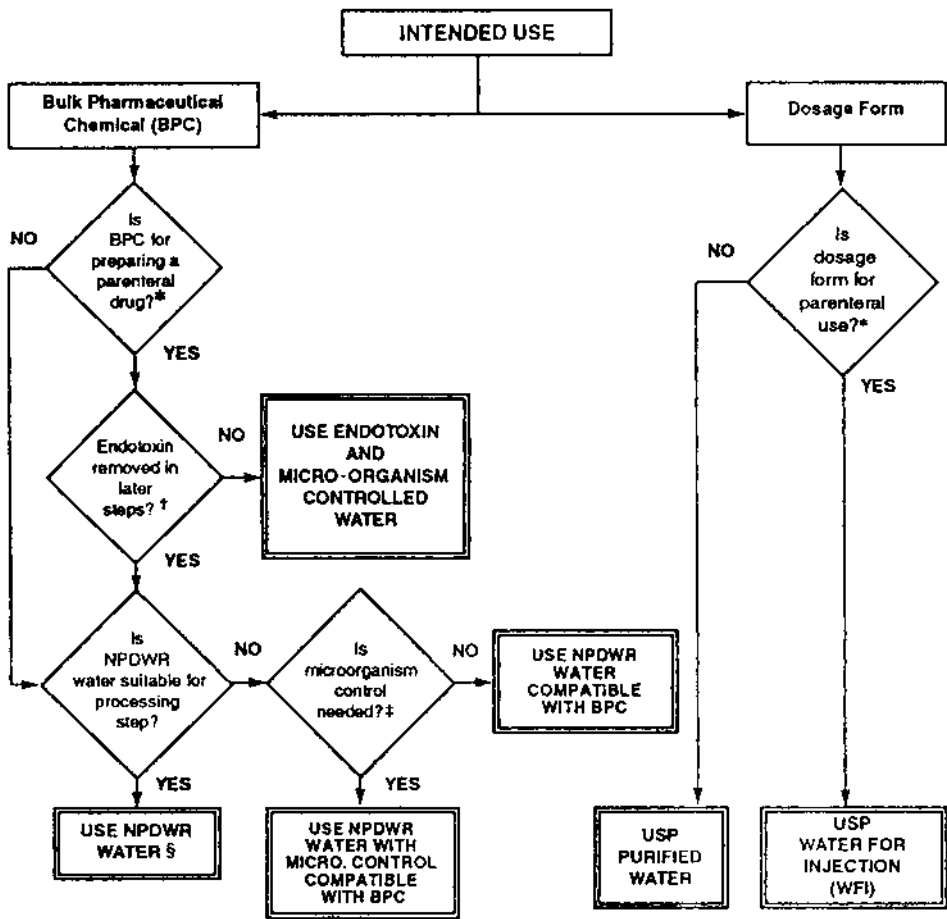
Water for injection obtained by distillation is circulated through the main loop and subloop at 80. During use the cooling water valve is open and the loop outlet valve is closed. After use the loop outlet valve is kept closed and the loop drain valve is opened to flush all the cooled water to drain.

A typical evaluation process to select an appropriate water quality for a particular pharmaceutical purpose is shown in the decision tree in [Figure 5](#) [2].

#### **D. Qualification of Equipment and Components for Water System**

Equipment and components used for the water system must maintain sanitary integrity and be anticorrosive and assured for technical integrity.





**Figure 5** Selection of water for pharmaceutical purpose. \*, Water for sterile BPCs or dosage forms must be rendered sterile if there is not a sterilization step following addition; ‡, microorganism control can occur either in water treatment or in BPC process; †, endotoxin removal can occur either in water treatment or in BPC process; §, NPDWR water—water meeting EPA national primary drinking water regulations. (From Ref. 2.)

## 1. Components

Selection should be made with assurance that it does not create a source for contamination intrusion.

## 2. Piping and Installation

Stainless steel welds should provide reliable joints that are internally smooth and corrosion-free. Low carbon stainless steel (SUS 304L, 316, and 316L) compatible wire filler, and where necessary, inert gas, automatic welding machines, and regular inspection and documentation, help to ensure acceptable weld quality. Follow-up cleaning and passivation are important for removing contamination and corrosion products and to re-establish the passive corrosion-resistant surface. Piping systems should be installed and sloped in such a way that they are completely self-draining. Complete drainage is important, as it prevents the formation of standing “pools” of liquid that can support the growth of microbes. Further, properly sloped piping prevents the formation of condensate “plugs” that can cause cold spots during SIP, and most important it allows for the free drainage of all rinsing and washing solutions during CIP, which enhances cleaning efficiency. The slope is normally 1/200 to 1/100. Isometric drawings of piping systems for water systems are essential for the design and installation qualification of both water supply and CIP/SIP piping systems.

## 3. Material

Materials of construction should be selected to be compatible with materials used as control measures, such as sanitizing, cleaning, and passivating media.

Plastic materials can be fused (welded) in some cases and also require smooth, uniform internal surfaces. Adhesives should be avoided due to the potential for voids and chemical reactions. Mechanical methods of joining, such as flange fittings, require care to avoid the creation of offsets, gaps, penetrations, and voids. Control measures include good alignment, properly sized gaskets, appropriate spacing, uniform sealing force, and the avoidance of threaded fittings.

Temperature rating is a critical factor in choosing appropriate materials because surfaces may be required to handle elevated operating and sanitization temperatures. Should chemicals or additives be used to clean, control, or sanitize the system, materials resistant to these chemicals or additives must be utilized.

## 4. Surface Polishing

The finish on metallic materials such as stainless steel, whether it be a refined mill finish, polished to a specific grit, or an electropolished treatment, should

complement system design and provide satisfactory corrosion and microbial activity resistance.

## 5. Dead Legs

Dead legs pose two problems for CIP. First, cleaning fluids must be able to flush out trapped gas pockets in order to wet all the piping surfaces in the dead legs. Second, fresh cleaning fluid must flush the dead leg to maintain rapid cleaning rates. Dead legs should not be greater in length than six diameters (6D) of the unused portion measured from the axis of the pipe in use.

## 6. Valves

The most commonly used valves in process piping systems for PW and WFI used for pharmaceutical manufacturing are diaphragm valves. This is because they are easily CIP-cleanable and provide complete containment of in-process materials. Diaphragm valves are limited in the ways they may be installed for free drainage; they sometimes are prone to leakage and they have a relatively high pressure drop as compared with other types of valves.

For situations in which complete containment is not required, “plunger-type” compression valves of hygienic design may be used. These have several advantages over diaphragm valves regarding installation and operation but they do not provide complete containment.

Ball and butterfly valves are also commonly used in water treatment systems. Diaphragm valves should be used downstream from the unit that removes dissolved solids (reverse osmosis unit or deionizer), however, because of their inherent ease of sanitation.

## 7. Pumps

Pumps should be of sanitary design with seals that prevent contamination of the water. Pumps moving water for manufacturing or final rinsing, water for cooling the drug product after sterilization, and in-process or drug product solutions shall be designed to utilize water for injection as a lubricant for the seals. Several types of CIP-cleanable pumps are commonly used in water systems or pharmaceutical manufacturing processes. These include centrifugal, rotary lobe, peristaltic, and diaphragm pumps, of which all but the centrifugal pump provide positive displacement.

## 8. In-Line Instrumentation

In-line instruments or sensors are necessary components for automated processes. For ease of cleaning, sensors should be chosen that directly mount onto vessel nozzles or piping tees with minimum dead leg distances. Also, the instru-

ments should be of a cleanable design and constructed to similar standards as those for process equipment and piping.

## 9. Pressure Gauges

Sanitary diaphragm-style pressure gauges should be used when possible, as they are very cleanable. When pressure gauges are installed in process piping, the diameter should be less than 6D.

## 10. Heat Exchangers

Heat exchangers should be double tube sheet or concentric tube design. Heat exchangers other than the welded double-concentric tube type or double-tube sheet type must employ a pressure differential and a means for monitoring the differential. The pressure differential shall be such that the fluid requiring a higher microbial quality shall be that with the greater pressure.

## 11. Distillation

Distillation equipment is used to produce USP WFI-quality water. The distillation process removes dissolved solids not otherwise removed by deionizers or RO units.

The chemical quality of the steam supplied to the still must be controlled to prevent recontamination of the distillate. Also, the condenser must be of a double-tube design to prevent condenser coolant from coming into direct contact with the distillate, thereby causing recontamination.

Separation of mists by the distillation process is important to remove the endotoxin or other contaminant. Distillators have their own upper limits of throughput capacity. Usually the more the amount of water generated at the unit period, the more the conductivity increases at the range of maximum capacity. This means that the purity of the water becomes worse.

## 12. Filters

Final filters of water for injectable products may not be used at any point in the piping system of water for manufacturing or final rinse.

Water storage tank vent filters must be equipped with a sterilizing air filter in order to prevent the air, which displaces water drawn from the tank, from microbiologically contaminating the water. The filter must be hydrophobic in order to prevent condensation from blinding the filter *and* preventing air entry or escape from the tank. It also must have a mean porosity of less than 1  $\mu\text{m}$ .

Water filters are used in various locations in water treatment systems for two basic purposes: removal of undissolved solids, some of which are added to the water by various components of the water treatment system, and removal of

bacterial contaminants. Filters are commonly used downstream from carbon beds and resin beds and on the incoming water supply line, and they are typically in the order of 10 to 15- $\mu\text{m}$  mean porosity. Membrane filters of 0.2  $\mu\text{m}$  are used to remove bacteria. Filters must be properly maintained in order to keep the water treatment system operating efficiently and to prevent them from becoming a source of bacterial and endotoxin contamination.

Microbes are not destroyed by bacteria-retentive filters but instead become concentrated in and on them. Certain bacteria have the capability of growing through a membrane filter. Also, filters can become damaged by frequent or sudden changes in water pressure (water hammer).

### 13. Deionizers

These devices are used to remove dissolved solids from the feed water. Deionizers use ion exchange resins to remove charged particles. Cation resin beds remove negatively charged particles; anion resins remove positively charged particles. Mixed bed deionizers (containing both cation and anion exchange resins) are commonly used to give the water a final “polishing” treatment. Resins lose their ability to remove charged particles and must be periodically regenerated using strong caustic and acid solutions. This treatment also sanitizes the resin beds, which, like carbon beds, are a fertile breeding ground for bacteria when improperly maintained.

### 14. Auxiliary Equipment

1. Backflow of liquids shall be prevented at points of interconnection of different systems.
2. Pipelines for the transmission of water for manufacturing or final rinse and other liquid components shall be constructed of welded stainless steel (nonrusting grade) equipped for sterilization with steam, except that sanitary stainless steel lines with fittings capable of disassembly may be immediately adjacent to the equipment or valves that must be removed from the lines for servicing and replacement.
3. Auxiliary equipment and fittings that require seals, gaskets, diaphragms, filter media, and membranes should exclude materials that permit the possibility of extractables entry, shedding, and microbial activity [7–12].

### 15. Ultraviolet Light

Ultraviolet light (UV) is not effective enough to eliminate existing biofilm. When coupled with conventional thermal or chemical sanitization technologies, however, it is most effective and can prolong the interval between system sanitizations.

The use of UV light also facilitates the degradation of hydrogen peroxide and ozone. The most effective biocidal wavelength is 253.7 nm. The amount of light at 255 nm emitted by a UV light decreases with time, so lamps have to be monitored and replaced when necessary.

## 16. Wastewater

Waste liquids shall be introduced to sewers through trapped drains. Drains from equipment shall be designed with an atmospheric break to prevent back-siphonage.

All stills and tanks holding liquid requiring microbial control shall have air vents with non-fiber-releasing sterilizable filters capable of preventing microbial contamination of the contents. Such filters shall be designed and installed so that they do not become wet. Filters shall be sterilized and installed aseptically. Tanks for holding water require air vents with filters [7,10].

## E. Sanitization

Microbial control in water systems is achieved primarily through sanitization practices. Systems can be sanitized using either thermal or chemical means. In-line UV light can also be used to “sanitize” water in the system continuously.

### 1. Thermal Approaches

Thermal approaches to system sanitization include periodic or continuously circulating hot water and the use of steam. These techniques are limited to systems that are compatible with the higher temperatures needed to achieve sanitization, such as stainless steel and some polymer formulations. Hot water circulation is effective or essential for this purpose, especially for the WFI system.

### 2. Chemical Methods

Chemical methods, where compatible, can be used on a wider variety of construction materials. These methods typically employ oxidizing agents such as hypochlorite, hydrogen peroxide, ozone, or per-acetic acid. Hypochlorites are effective sanitizers but are difficult to flush from the system and tend to leave biofilms intact.

### 3. Validation of Sanitization Steps

Sanitization steps require validation to demonstrate the capability of reducing and holding microbial contamination at acceptable levels. Validation of thermal methods should include a heat distribution study to demonstrate that sanitization temperatures are achieved throughout the system. Validation of chemical meth-

ods requires a demonstration of adequate chemical concentrations throughout the system. In addition, when the sanitization process is completed, effective removal of chemical residues must be demonstrated.

The frequency of sanitization is generally dictated by the results of system monitoring. Conclusions derived from the trend analysis of the microbiological data should be used as the alert mechanism for maintenance. The frequency of sanitization should be established so that the system operates in a state of microbiological control and does not exceed alert levels.

#### 4. SIP/CIP

For a WFI or highly purified water system, the SIP/CIP method is usually applied. In an SIP/CIP system, sterilization and/or cleaning take in place in situ or without disassembling the equipment. Consequently, the result of sterilization and/or cleaning is confirmed by the process parameters previously validated. Based on process parameters and their ranges previously determined by the process validation, the SIP/CIP process can be confirmed whether or not it is completely sterilized and cleaned. This is a typical application of the concept of validation.

#### 5. Hot Water Circulation of WFI System

Hot water circulation systems circulate hot water through all pipelines from the storage tank through all use points to return to the storage tank. By a combination of hot water circulation system and SIP, microbial quality of WFI can be guaranteed to be 0 cfu per 100 ml. Once the water in the system is drained out, the entire system must be steam-sterilized. By applying hot water circulation and SIP, formation of any biofilm can be prevented if the piping and installation are well designed and there are no dead legs [2,7–9,11,12].

### F. Sampling Considerations

Water systems should be monitored at a frequency that is sufficient to ensure that the system is in control and continues to produce water of acceptable quality. Samples should be taken from representative locations within the processing and distribution system. Established sampling frequencies should be based on system validation data and should cover critical areas. Unit operation sites might be sampled less frequently than point-of-use sites. The sampling plan should take into consideration the desired attributes of the water being sampled. Because of their more critical microbiological requirements, systems for WFI may require a more rigorous sampling frequency.

When sampling water systems, special care should be taken to ensure that the sample is representative. Sampling ports should be sanitized and thoroughly flushed before a sample is taken. Samples for microbiological analysis should

be tested immediately or suitably protected to preserve the sample until analysis can begin. The sampling operation itself might often cause a microbial contamination.

## 1. Biofilm, Planktonic Micro-Organisms, and Benthic Micro-Organisms

Samples of flowing water are only indicative of the concentration for planktonic (free-floating) micro-organisms present in the system. The number of microbes determined by the water system monitoring is an indication of floating microbes in water; that is, planktonic micro-organisms. Benthic (attached) micro-organisms in the form of biofilms are generally present in greater numbers and are the source of the planktonic population.

The major purpose of monitoring microbes is to identify the generation of biofilms and to find the locations of biofilms, if any. The purpose of sanitization is to kill and destroy the biofilm after detecting the location of the biofilms. The planktonic population, whose number of micro-organisms in water is monitored, should be understood and utilized to indicate biofilms in the system. The number of microbes in water is an indicator of system contamination levels and is the basis for the system alert levels.

If there were no microbials in water, there would not be any biofilms in the system. If any microbials are detected in the system, there must be biofilms in some locations. Biofilm is formed in stagnant places, such as valves, dead ends, or unsuitably sloped piping. Detecting micro-organisms and biofilms is one method of controlling the cleanliness of the system. The other method is to completely eliminate the stagnant places or dead ends that might cause biofilms. From such viewpoints, the design and construction of a desirable water system as described in sec. III.D is the fundamental way to prevent the formation of biofilms, and consequently to both reduce the number of micro-organisms and prevent the generation of micro-organisms in the system.

## 2. Operation, Monitoring, and Control

Monitoring programs should be established to ensure that the water system remains in a state of control. The program should include

1. Procedures for operating the system
2. Monitoring programs for critical quality attributes and operating conditions, including calibration of critical instruments
3. Schedule for periodic sanitization
4. Preventive maintenance of components
5. Control of changes to the mechanical system and to operating conditions



### 3. Operating Procedures

Procedures for operating the water system and performing a routine monitoring program should be established based on the validation study. The procedures should be well documented, detail the function of each job, assign who is responsible for performing the work, and describe how the job is to be conducted.

### 4. Monitoring Program

Critical quality attributes and operating parameters should be documented and monitored. The program may include a combination of in-line sensors or recorders (e.g., a conductivity meter and recorder), manual documentation of operational parameters (such as carbon filter pressure drop), and laboratory tests (e.g., total microbial counts). The frequency of sampling, the requirement for evaluating test results, and the necessity for initiating corrective action should be included.

## G. Microbial Considerations

The major exogenous source of microbial contamination is source or feed water. At a minimum, feed water quality must meet the quality attributes of potable water for which the level of coliforms is regulated. A wide variety of other micro-organisms, chiefly gram-negative bacteria, may be present. These micro-organisms may compromise subsequent purification steps. Examples of other potential exogenous sources of microbial contamination include unprotected vents, faulty air filters, backflow from contaminated outlets, drain air breaks, and replacement activated carbon and deionizer resins. Sufficient care should be given to system design and maintenance in order to minimize microbial contamination from these sources.

Micro-organisms present in feed water may adsorb to carbon beds, deionizer resins, filter membranes, and other unit operation surfaces and initiate the formation of a biofilm [2,8].

## H. Endotoxin

Endotoxins are lipopolysaccharides from the cell envelope that is external to the cell wall of gram-negative bacteria. Gram-negative bacteria readily form biofilm that can become a source of endotoxin. Endotoxin may be associated with living micro-organisms or fragments of dead micro-organisms, or may be free molecules. The free form of endotoxin may be released from cell surfaces or biofilm that colonize the water system, or they may enter the water system via the feed water.

Endotoxin should be eliminated by means of distillation, reverse osmosis, and/or ultrafiltration. Generation of endotoxin is prevented by controlling the

introduction of micro-organisms and microbial proliferation in the system. This may be accomplished through sanitization and sterilization.

The presence of endotoxin should be monitored by LAL method in the routine operation. Endotoxin can be removed by means of distillation, reverse osmosis, and/or ultrafiltration. Incomplete separation of mist in distillation, however, and leakage in membrane of reverse osmosis or ultrafiltration cause contamination with endotoxin. After these separation processes, of course, contamination of microbes or growth of microbes causes endotoxin contamination [2,8].

## **I. Methodological Considerations**

The objective of a water system microbiological monitoring program is to provide sufficient information to control the microbiological quality of the water produced. An appropriate level of control may be maintained by using data trending techniques and limiting specific contraindicated micro-organisms, consequently it may not be necessary to detect all of the micro-organisms present. The methods selected should be capable of isolating the numbers and types of organisms that have been deemed significant relative to system control and product impact for each individual system [2,8].

## **J. Continuous Automatic Monitoring of Water**

Monitoring and feeding back the data are important in maintaining the performance of water systems. By applying an automatic continuous monitoring system combined with the method of trend analysis, processes can be maintained in a much more stable state. For example, this can be achieved by applying automatic continuous monitoring of TOC and conductivity of the water system.

TOC and conductivity are the major quality attributes of water by which organic and inorganic impurities can be determined.

## **IV. QUALIFICATION OF AIR HANDLING SYSTEMS**

### **A. Purposes of an Air Handling System**

The purposes of an air handling system are

1. To prevent microbial contamination of sterile products and of clean areas
2. To prevent the spreading and contamination of virus, pathogenic, and spore-forming microbes used in the manufacturing of pharmaceuticals
3. To prevent spread and contamination of penicillin or other *sensitizing* drugs, cytotoxic drugs, and drugs with strong pharmacological action

4. To prevent cross-contamination of solid dosage form or bulk pharmaceuticals, whose fine powder tends to spread and disperse

CFR211.46 states that “a) Adequate ventilation shall be provided. b) Equipment for adequate control over air pressure, micro-organisms, dust, humidity, and temperature shall be provided when appropriate for the manufacture, processing, packaging, or holding of a drug product. c) Air filtration system, including prefilters and particulate matter air filters, shall be used when appropriate on air suppliers to production areas.”

In the air handling system, special attention has to be paid to keep the environment clean and to prevent the contamination of products. There are two different kinds of concepts to control the air system: one is to prevent intrusion of the surrounding air (positive air pressure control), and the other is for the containment of air containing an undesirable substance generated in the operation area (negative air pressure control). Air handling systems should be designed, installed, and maintained to meet these purposes.

## **B. The Concept of Air Handling System Validation**

The degree of cleanliness of air in the pharmaceutical manufacturing and related operation area should be established depending on the characteristics of products and operations in the area. In order to establish and maintain such standards, careful attention has to be exercised to keep the standards from the stage of design and construction through to the monitoring in the stage of routine operations.

A total air handling system, covering the open air intake, treatment, the supply to the manufacturing area, and the exhaust, should be designed and validated. The handling system contains units of prefiltration, temperature and humidity control, final air filtration, return, and exhaust. When the air is supplied to the manufacturing area, care is required in maintaining the required air quality during the operation or at the point of product exposure to the environment. This point is closely related to the layout and construction features of the manufacturing area.

1. The air must flow from the critical or most clean area to the surrounding area; that is, the less clean area. For this purpose, rooms used for the manufacturing operation have to be laid out according to the order of the required air cleanliness.
2. In order to maintain the air cleanliness in the area and airflow, the amount of air supplied and exhaust have to be balanced to keep the designed air exchange ratio, airflow pattern, and air pressure differentials. In each room the operation site should be maintained in the most suitable status. For such purposes, the following items must be carefully controlled:

- a. Locations and number of air supplies
- b. Locations and number of air exhausts
- c. Ratio of air exchange
- d. Return ratio of exhaust air
- e. Location of local air exhaust, if necessary
- f. Airflow pattern at the site of product exposure
- g. Air velocity at the point of product exposure

These features have to be well designed, installed, validated, and maintained. Critical operation has to be performed under the unidirectional airflow (laminar airflow). Air turbulence deteriorates air quality by intake of air from the surrounding less clean areas.

The amount of air supplied and exhausted is related to the air pressure differentials. After the system is validated, air quality should be continuously monitored and maintained during manufacturing operations.

Filters used for the prefiltration and final filtration should be maintained to operate to their design specifications. Deterioration of filters is caused by leakage and/or accumulation of particles. The former is tested by periodical integrity test (usually dioctylphthalate DOP test), and the latter is tested by the increase of air pressure differentials between the upstream and downstream sides of the filter.

### **C. Validation of Air Handling Systems**

All of the environmentally-controlled areas of pharmaceutical manufacturing and its related areas should meet the requirement of air cleanliness, which is expressed as classifications specified by official standards, such as ISO (International Organization of Standardization) or FED-STD (U.S. federal standard) 209, and/or GMP. The classification has a close relationship with the air treatment procedures and construction features.

1. First of all, the most suitable quality grade of air for the manufacturing environment, and operation performed has to be selected.
2. Second, the air handling system/method that suits the facility and combination of equipment has to be designed. Therefore, design qualification is the first step of the validation.
3. Before completing construction of the air handling system, the constructed system has to be scrutinized as to whether or not it is built according to the design.
4. After confirming the installation of facility and equipment, the quality of air is examined from various viewpoints according to the predetermined specifications.
5. In the routine operation, representative quality items have to be moni-

tored to confirm the performance of normal operation, and if any undesirable trends or out of specification results are found, corrective action should be taken. These processes of checking design and construction, confirmation of proper installation and operation, and documentation of these processes are termed qualification/validation.

6. In case of system change or any changes of equipment, the same procedure should be taken. These processes are summarized as follows:
  - a. Selection of air quality
  - b. Determination of air handling system and design of the construction features
  - c. Construction and qualification of installation
  - d. Test run and operational qualification
  - e. Operation of air handling system and confirmation of the air quality; that is, qualification of operation, and monitoring of operations; that is, operational qualification
  - f. Revalidation, or change control [9,10,12]

## **D. Classification of Air Quality and Design Qualification**

### **1. Establishment of Clean Room Classifications**

The design and construction of clean rooms and controlled environments are specified in USP, FED-STD 209E, and ISO air cleanliness standards. The cleanliness classifications are defined by the absolute concentration of airborne particles. Methods used for the assignment of air classification of controlled environments and for monitoring airborne particulates are included in these standards. FED-STD 209E or ISO standards of air cleanliness and controlled environments are used by pharmaceutical manufacturers to provide specifications for clean rooms and the commissioning and maintenance of these facilities. Data available in the pharmaceutical industry, however, provide no scientific agreement on a relationship between the number of nonviable particulates and the concentration of viable micro-organisms. Nevertheless, the rationale that the fewer particulates present in a clean room the less likely it is that airborne micro-organisms will be present is accepted and can provide pharmaceutical manufacturers and builders of clean rooms and other controlled environments with engineering standards in establishing a properly functioning facility.

As applied in the pharmaceutical industry, FED-STD 209E and ISO Air Cleanliness Standards are based on limits of all particles with sizes equal to or larger than 0.5  $\mu\text{m}$ . [Table 2](#) describes airborne particulate cleanliness classes in federal standard 209E and ISO air cleanliness standards as adapted to the pharmaceutical industry. It is generally accepted that if fewer particulates are

**Table 2** Air Quality Classification and Concentrations of Controlled Environment

Particles per m <sup>3</sup> >0.1 μm	Particles per m <sup>3</sup> ≥ 0.5 μm	ISO classification of airborne particulates	U.S. 209E (1992)	USP 209E customary	EEC/CGMP (1989)/WHO GMP
—	1.00	—	—	—	—
10 <sup>2</sup>	3.50	ISO class 2	—	—	—
—	1.00	—	M1	—	—
10 <sup>3</sup>	35.30	ISO class 3	M1.5	1	—
—	10 <sup>2</sup>	—	M2	—	—
10 <sup>4</sup>	3.53 × 10 <sup>2</sup>	ISO class 4	M2.5	10	—
—	10 <sup>3</sup>	—	M3	—	—
10 <sup>5</sup>	3.53 × 10 <sup>3</sup>	ISO class 5	M3.5	10 <sup>2</sup>	A&B
—	10 <sup>4</sup>	—	M4	—	—
10 <sup>6</sup>	3.53 × 10 <sup>4</sup>	ISO class 6	M4.5	10 <sup>3</sup>	—
—	10 <sup>5</sup>	—	M5	—	—
10 <sup>7</sup>	3.53 × 10 <sup>5</sup>	ISO class 7	M5.5	10 <sup>4</sup>	C
—	10 <sup>6</sup>	—	M6	—	—
10 <sup>8</sup>	3.53 × 10 <sup>6</sup>	ISO class 8	M6.5	10 <sup>5</sup>	D
—	10 <sup>7</sup>	—	M7	—	—

Source: Refs. 15, 19.

present in an operational clean room or other controlled environment, the less the microbial count under operational conditions.

Clean rooms are maintained under a state of operational control on the basis of dynamic (operational) data. Class limits are given for each class name. The limits designate specific concentrations (particles per unit volume) of airborne particles with sizes equal to and larger than the particle sizes shown in Table 2 [7,10–12,14].

Air quality relating to the manufacturing of sterile pharmaceutical products is designated in WHO and EU GMP as A, B, C, and D, and in USP as class 100, class 10,000, and class 100,000. These classes correspond to ISO class 5, ISO class 7, and ISO class 8, respectively (there is no class corresponding to B grade in FDA/USP) [13–19].

## 2. ISO Classification of Air Cleanliness

The ISO air cleanliness level (class) is expressed in terms of an ISO air classification number (class N). This represents the maximum allowable concentrations (in particles/quantity of air) for considered sizes of particles [18,19]. The concentrations are determined by using the formula given below.

Airborne particulate cleanliness shall be designated by a classification number  $N$ . The maximum permitted concentration of particles  $C_n$  for each considered particle size  $D$  is determined from the formula

$$C_n = 10^N \times \left( \frac{0.1}{D} \right)^{2.08}$$

where

$C_n$  represents the maximum permitted concentration (in particles/m<sup>3</sup> of air) of airborne particles that are equal to or larger than the considered particle size.  $C_n$  is rounded to the nearest whole number, using no more than three significant figures.

$N$  is the ISO classification number, which shall not exceed a value of 9.

$D$  is the considered particle size in  $\mu\text{m}$ .

0.1 is a constant with a dimension of  $\mu\text{m}$ .

Figure 6 presents relationships between sizes of airborne particulates and concentrations in each ISO air cleanliness class. The relationship between the requirement for air cleanliness and manufacturing operation is summarized in Table 3.

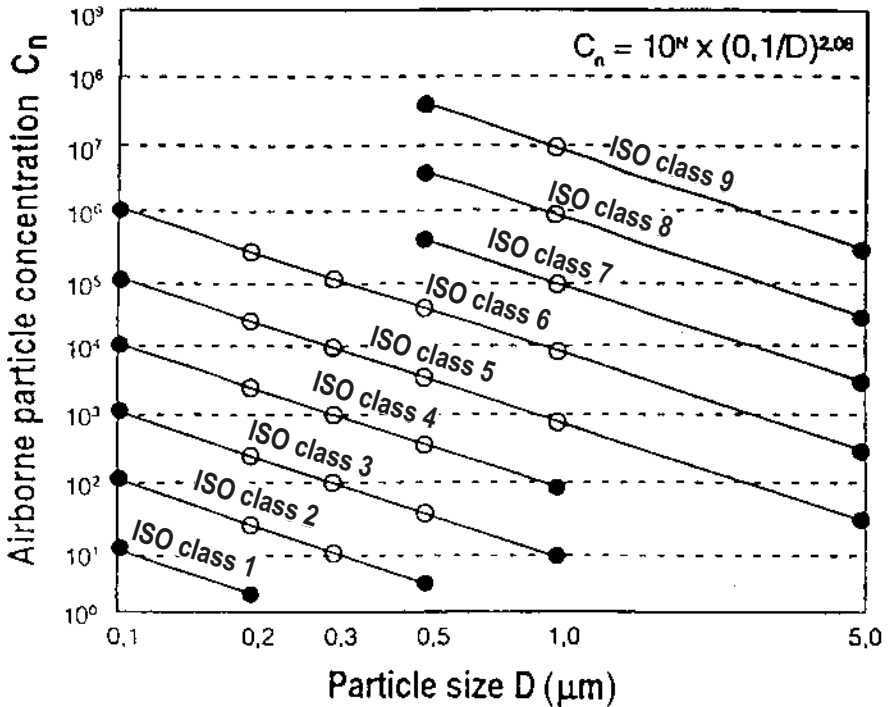
Aseptic processing and processes related to sterile products manufacturing should be carried out in the environment of the area under the defined air quality.

Airflow should also be designed, validated, and confirmed to be maintained as such by the monitoring of air quality. There are no official requirements for the manufacturing of nonsterile products; however, air quality and airflow should be designed, validated, and monitored for the purpose of preventing contamination.

## **E. Unidirectional Airflow (Laminar Flow) Control Equipment**

Area A (class 100, ISO class 5), which applies to air handling equipment at the filling line and microbiological testing area, shall provide HEPA-filtered laminar-flow air. (Note: The term laminar flow has not been used recently; instead the term “unidirectional air flow” is used [FED-STD-209E, Sept. 11, 1992]. Unidirectional airflow [referred to as laminar airflow] is an airflow having generally parallel streamlines, operating in a single direction, and with uniform velocity over its cross section [15,19].

Such equipment shall



**Figure 6** ISO classification of airborne particulate cleanliness. (From Ref. 19.)

1. Have hood or airflow direction panels and working surface areas that are constructed of a smooth, durable, nonflaking material, such as glass, plastic, or stainless steel.
2. Have prefilters that are disposable or fabricated from a material that can be properly cleaned and reused.
3. Have HEPA final filters that have been tested to assure leak-proof construction and installation.
4. Provide a laminar airflow with an average velocity of 90 ft per min over the entire air exit area. The air velocity should be high enough to maintain the unidirectional flow pattern.
5. Be monitored according to a written program and scheduled for compliance with the requirements.

Schematic construction features for an aseptic processing area are shown in [Figure 7](#).



**Table 3** Air Quality Classification and Process Step

Typical process step	Products for European supply		
	Terminally sterilized		
	Not unusually at risk	Unusually at risk	Aseptically processed
Dispensing	Grade D	Grade C (controlled)	Grade C (controlled) <sup>a</sup>
Compounding	Grade D	Grade C (controlled)	Grade C (controlled) <sup>a</sup>
Filtration	From grade D to grade C (controlled)	From grade C (controlled) to grade A (critical) or closed systems	From grade C (controlled) to grade A (critical) [background grade B (clean)] or closed systems
Container prep/wash + stopper prep/wash	Grade D	Grade C (controlled)	Grade D
Container sterilization	From grade D to grade C (controlled)	From grade C (controlled) to grade A (critical)	From grade D to grade A (critical)
Depryogenation			
Stopper Sterilization	From grade D to grade C (controlled)	From grade C (controlled) to grade A (critical)	From grade D to grade A (critical)
Filling and stoppering	Grade C (controlled)	Grade A (critical) [background grade C (controlled)]	Grade A (critical) [background grade B (clean)]
Lyophilization	—	—	Grade A (critical) [background grade B (clean)]

*Note.* Capping and crimping, terminal sterilization, inspection and labeling and packaging “pharmaceuticals.”

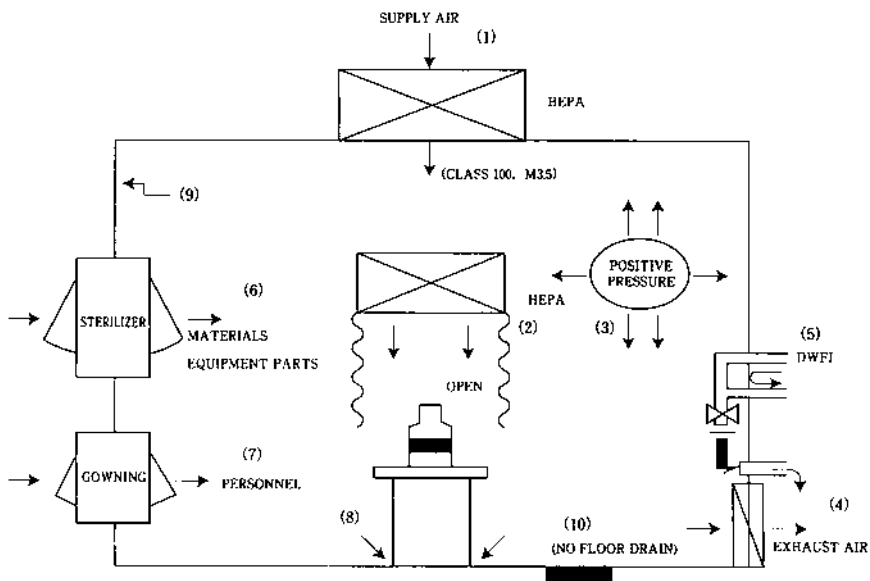
<sup>a</sup>For European aseptically produced products with sterile raw materials, where sterile filtration is not carried out, then dispensing and compounding shall be in a grade A area, with a grade B background.

*Source:* Refs. 14, 20.

## F. Performance Qualification and Parameters of Cleanliness

A controlled environment such as a clean zone or clean room is defined by certification according to a relevant clean room operational standard. Parameters that are evaluated include

1. Number of airborne particles
2. Number of airborne microbes
3. Filter integrity, including HEPA filter leak test



**Figure 7** Major construction features for aseptic processing. (From Ref. 12.)

4. Air velocity
5. Airflow patterns
6. Air changes ratio
7. Pressure differentials

These parameters can affect the microbiological bioburden of the clean room. Proper testing and optimization of the physical characteristics of the clean room or controlled environment is essential prior to completion of the validation of the microbiological monitoring program. Assurance that the controlled environment is operating adequately and according to its engineering specifications will give a higher assurance that the bioburden of the environment will be appropriate for aseptic processing.

### **G. Microbiological Evaluation Program for Controlled Environments**

Airborne micro-organisms are not free-floating or single cells, but they frequently associate with particles of 10 to 20  $\mu\text{m}$ . Particulate counts as well as microbial counts within controlled environments vary with the sampling location and the activities being conducted during sampling.

Microbial monitoring programs for controlled environments should assess the effectiveness of cleaning and sanitization practices by and of personnel that

could have an impact on the bioburden of the controlled environment. Microbial monitoring will not quantitate all microbial contaminants present in these controlled environments. Routine microbial monitoring should provide sufficient information to ascertain that the controlled environment is operating within an adequate state of control, however.

Environmental microbial monitoring and analysis of data by qualified personnel will permit the status of control to be maintained in clean rooms and other controlled environments. The environment should be sampled during normal operations to allow for the collection of meaningful data. Microbial sampling should occur when materials are in the area, processing activities are ongoing, and a full complement of operating personnel is on site.

When appropriate, microbial monitoring of clean rooms and some other controlled environments should include quantitation of the microbial content of room air, compressor air that entered the critical area, surfaces, equipment, sanitization containers, floors, walls, and personnel garments (e.g., gowns and gloves).

The objective of the microbial monitoring program is to obtain representative estimates of the bioburden of the environment. When data are compiled and analyzed, any trends should be evaluated by trained personnel. While it is important to review environmental results on the basis of recommended and specified frequency, it is also critical to review results over extended periods to determine whether or not trends are present. Trends can be visualized through the construction of statistical control charts that include alert and action levels. The microbial control of controlled environments can be assessed in part on the basis of these trend data. Periodic reports or summaries should be issued to alert the responsible manager [13].

## **H. Training of Personnel**

The major source of microbial contamination of controlled environments is personnel. Since the major threat of contamination of product being aseptically processed comes from the operating personnel, the control of microbial contamination associated with these personnel is one of the most important elements of the environmental control program. Personnel training should be conducted before the qualification and validation practice [13].

## **I. Sampling and Test of Air Quality**

### **1. Critical Factors Involved in the Design and Implementation of a Microbiological Environmental Control Program**

An environmental control program should be capable of detecting an adverse drift in microbiological conditions in a timely manner that would allow for meaningful and effective corrective actions. An appropriate environmental control program should include identification and evaluation of sampling sites and validation of methods for microbiological sampling of the environment.

## 2. Establishment of Sampling Plans and Sites

During initial start-up or commissioning of a clean room or other controlled environment, specific locations for air and surface sampling should be determined.

1. Consideration should be given to the proximity to the product and whether or not the air and surfaces might be in contact with a product or sensitive surfaces of container closure systems. Such areas should be considered critical areas requiring more monitoring than non-product-contact areas.
2. The frequency of sampling will depend on the criticality of specified sites and the subsequent treatment received by the product after it has been aseptically processed. Table 4 shows suggested frequencies of sampling in decreasing order of frequency of sampling and in relation to the criticality of the area of the controlled environment being sampled. The sampling plans should be dynamic, with monitoring frequencies and sample plan locations adjusted based on trending performance. It is appropriate to increase or decrease sampling based on this performance.

## 3. Sampling Method by ISO Air Cleanliness Standards

*Establishment of Air Sampling Locations.* Derive the minimum number of sampling point locations from the formula

$$N_L = \sqrt{A}$$

where

$N_L$  is the minimum number of sampling locations (rounded to a whole number).

**Table 4** Suggested Frequencies of Sampling on the Basis of Criticality of Controlled Environment

Sampling area	Frequency
Class 100 or better room	Each operating shift
Supporting areas adjacent to class 100	Each operating shift
Other support areas (class 100,000)	Twice/week
Potential product/container contact areas	Twice/week
Other support areas to aseptic processing	
Areas but nonproduct contact (Class 100,000 or lower)	Once/week

Source: Ref. 13.

A is the area of the clean room or clean air controlled space in m<sup>2</sup>. In the case of unidirectional perpendicular airflow, the area A may be considered as the cross section of air horizontal to the airflow.

It should be ensured that the sampling locations are evenly distributed throughout the area of the clean room or clean zone and positioned at the height of the work activity.

#### 4. Establishment of Single Sample Volume Per Location

Sample a sufficient volume of air at each location that a minimum of 20 particles would be detected if the particle concentration for the relevant class were at the class limit for the largest considered particle size.

The single sample volume  $V_s$  per location is determined by using the formula

$$V_s = \frac{20}{C_{n,m}} \times 1000$$

where

$V_s$  is the minimum single sample volume per location, expressed in liters.

$C_{n,m}$  is the class limit (number of particles/m<sup>3</sup>) for the largest considered particle size specified for the relevant class.

20 is the defined number of particles that could be counted if the particle concentration were at the class limit.

When  $V_s$  is very large, the time required for sampling can be substantial. By using the sequential sampling procedure both the required sample volume and the time required to obtain samples may be reduced.

The sampling probe shall be positioned pointing into the airflow. If the direction of the airflow being sampled is not controlled or predictable (e.g., nonunidirectional airflow), the inlet of the sampling probe shall be directed vertically upward. At a minimum, sample the above-determined volume of air at each sampling location.

#### 5. Interpretation of Results by ISO Air Cleanliness Standard

The clean room or clean zone is deemed to have met the specified air cleanliness classification if the averages of the particle concentrations measured at each of the locations and, when applicable, the 95% upper confidence limit, do not exceed the concentration limits required [13,15,19].

## **J. Continuous Automatic Monitoring of Air**

Continuous automatic air monitoring for multipoints can provide much more information about the environment. Using the statistical analysis of the data obtained by the continuous multipoints monitoring is the best method to monitor the air cleanliness and to take necessary actions before the data exceed an alert level or an action level. The method has many advantages over the data obtained by discrete monitoring methods.

In the continuous automatic monitoring of the air quality, in which a remote probe is used, it must be determined that the extra tubing does not have an adverse effect on the viable airborne count. This effect should either be eliminated, or if this is not possible, a correction factor should be introduced in reporting the results. The number of sampling ports should be calculated according to the formula described previously, and sampling ports should be located as mentioned above. In addition to the specified number of sampling ports, sampling ports should be placed at the critical positions by considering the nature of the operation.

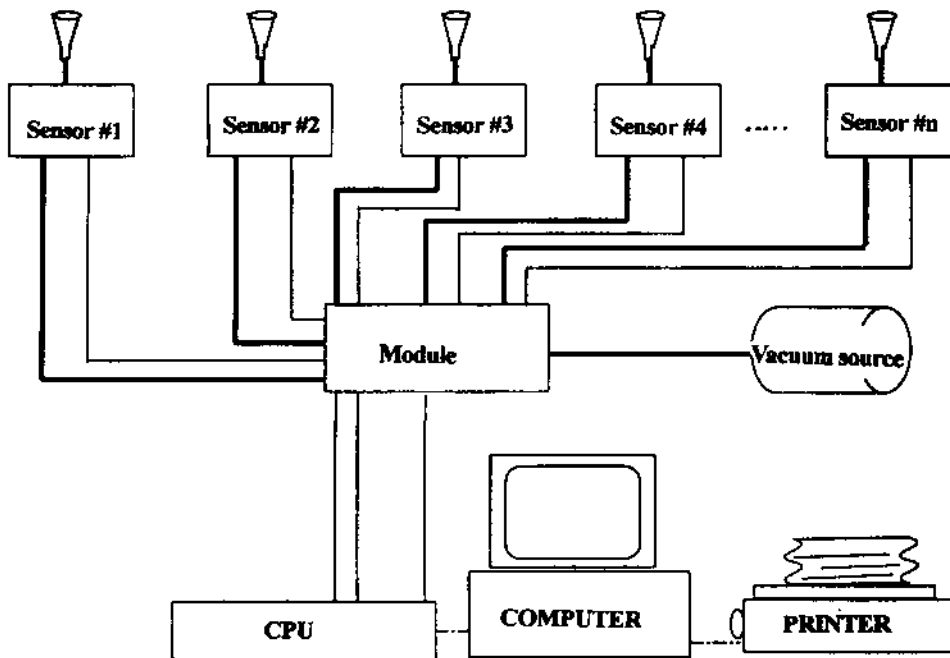
By applying this kind of continuous monitoring system, we can always know the real-time state of air cleanliness and its trend [12]. This also affords information as to the state of integrity of the HEPA filter without waiting for the result of a DOP integrity test (usually performed every 6 months). A schematic drawing of a continuous automatic air sampler is shown in [Figure 8](#). An example of monitoring data is shown in [Figure 9](#).

## **K. Establishment of Microbiological Alert and Action Levels in Controlled Environments**

The principles and concepts of statistical process control are useful in establishing alert and action levels and in reacting to trends. An alert level in microbiological environmental monitoring is that level of micro-organism that shows a potential drift from normal operating conditions. Exceeding the alert level is not necessarily grounds for definitive corrective action, but it should at least prompt a documented follow-up investigation that could include sampling plan modifications. An action level in microbiological environmental monitoring is the level of micro-organism that when exceeded requires immediate follow-up and, if necessary, corrective action.

Initially alert levels are established based upon the result of PQ, and reviewed based on the historical information gained from the routine operation of the process in a specific controlled environment.

Trends that show a deterioration in environmental quality require attention in determining the assignable cause and in instituting a corrective action plan to bring the conditions back to the expected ranges. An investigation should be implemented, however, and the potential impact should be evaluated. Although there is no direct relationship established between the 209E or ISO air cleanliness standard controlled environment classes and microbiological levels, the pharma-



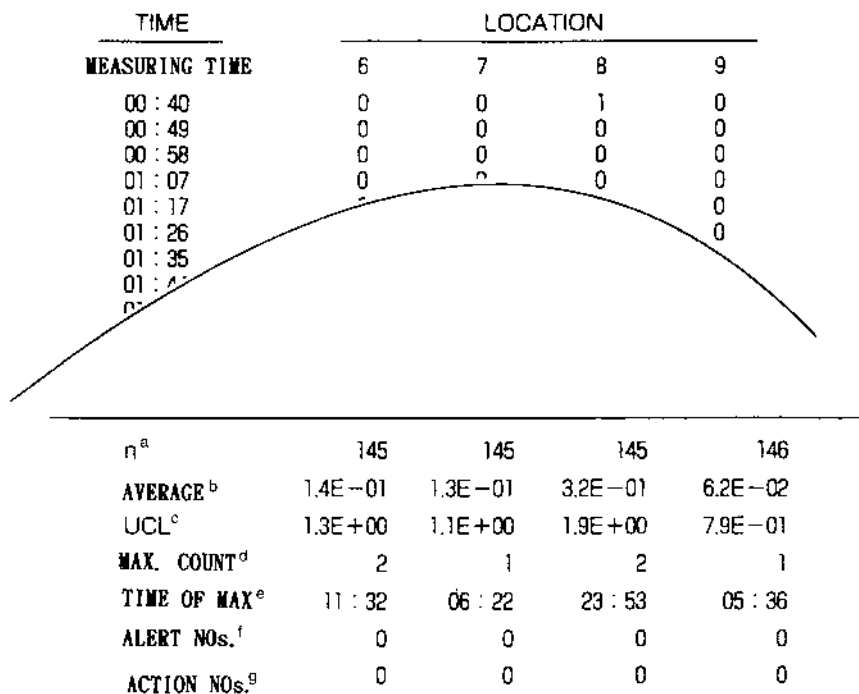
**Figure 8** Schematic drawing of continuous automatic air monitoring system.

ceutical industry has been using microbial levels corresponding to air cleanliness classes for a number of years, and these levels (shown in [Table 5](#)) have been specified in various official compendia for evaluation of current GMP compliance [13–16,19].

#### **L. Methodology and Instrumentation for Quantitation of Viable Airborne Micro-Organisms**

It is generally accepted that airborne micro-organisms in controlled environments can influence the microbiological quality of the intermediate or final products manufactured in these areas. Also, it is generally accepted that estimation of the airborne micro-organisms can be affected by instruments and procedures used to perform these assays.

The most commonly used samplers in the pharmaceutical and medical device industry are impaction and centrifugal samplers. The selection, appropriateness, and adequacy of using any particular sampler is the responsibility of the user.



**Figure 9** Output example of continuous airborne particle measurement system.

1. *Slit-to-agar air sampler (STA)*. This sampler is the instrument upon which the microbial guidelines given in [Table 3](#) for the various controlled environments are based. The unit is powered by an attached source of controllable vacuum. The air intake is obtained through a standardized slit below which is placed a slowly revolving petri dish containing a nutrient agar. Particles in the air that have sufficient mass impact on the agar surface and viable organisms are allowed to grow out. A remote air intake is often used to minimize disturbance of the laminar flow field.
2. *Sieve impactor*. This apparatus consists of a container designed to accommodate a petri dish containing a nutrient agar. The cover of the unit is perforated, with the perforations of a predetermined size. A vacuum pump draws a known volume of air through the cover, and the particles in the air containing micro-organisms impact on the agar medium in the petri dish. Some samplers are available with a cascaded series of containers containing perforations of decreasing size.



**Table 5** Comparison of Numbers of Viable Organisms Allowed by EU GMP Directive and USP Chapter <1116>

Class		Air (CFU per m <sup>3</sup> )		Surfaces (dfu per contact plate)		Settle plates, (cfu per 4 hr; 90 mm)		Descriptive	
EU (grade)	ISO air class	USP customary	EU	USP	EU (55 m)	USP (24–30 cm <sup>2</sup> )	EU		USP
A	ISO class 5	100 M 3.5	<1	3	<1	3	<1	—	Critical <sup>a-c</sup>
B	ISO class 5	100 M 3.5	10	—	5	—	5	—	
C	ISO class 7	10,000 M 5.5	100	20	25	5 (floor:10)	50	—	Clean
D	ISO class 8	100,000 M 6.5	200	100	50	—	50	—	Controlled <sup>c</sup> , non-sterile, support area

<sup>a</sup>Ref. 13.<sup>b</sup>Ref. 14.<sup>c</sup>Aseptic Processing of Health Care Product—Part 1, General—ISO 13408-1, International Organization for Standardization, Geneva (1998).

These units allow for the determination of the distribution of the size ranges of particles containing viable micro-organisms, based on which size perforations admit the particles onto the agar plates.

3. *Centrifugal sampler.* The unit consists of a propeller or turbine that pulls a known volume of air into the unit and then propels the air outward to impact on a tangentially placed nutrient agar strip set on a flexible plastic base.
4. *Surface air system sampler.* This integrated unit consists of an entry section that accommodates an agar contact plate. Immediately behind the contact plate is a motor and turbine that pull air through the unit's perforated cover over the agar contact plate and beyond the motor, where it is exhausted. Multiple mounted assemblies are also available.
5. *Gelatin filter sampler.* The unit consists of a vacuum pump with an extension hose terminating in a filter holder that can be located remotely in the critical space. The filter consists of random fibers of gelatin capable of retaining airborne micro-organisms. After a specified exposure time, the filter is aseptically removed and dissolved in an appropriate diluent and then plated on an appropriate agar medium to establish its microbial content.
6. *Settling plates.* This method is still widely used as a simple and inexpensive way to quantitatively assess the environments over prolonged exposure times. The exposure of open agar-filled petri dishes or settling plates are not to be used for quantitative estimations of the microbial contamination levels of critical environments.

One of the major limitations of mechanical air samplers is the limitation in sample size of the air being sampled. Where the microbial level in the air of a controlled environment is expected to contain not more than 3 cfu per cubic meter, several cubic meters of air should be tested if the results are to be assigned a reasonable level of precision and accuracy. Often this is not practical. For example, slit-to-agar samplers have an 80-L-per-min sampling capacity. If 1 cubic meter of air is tested, then it would require an exposure time of 15 min. It may be necessary to use sampling times in excess of 15 min to obtain a representative environmental sample. Although there are samplers capable of very high sampling volume rates, consideration in these situations should be given to the potential for disruption of the airflow patterns in any critical area or to the creation of a turbulence that could increase the probability of contamination. For centrifugal air samplers, a number of earlier studies showed that the samples demonstrated a selectivity for larger particles. The use of this type of sampler may have resulted in higher airborne counts than the other types of air samplers because of the inherent selectivity. When selecting a centrifugal sampler, the effect of the sampler on the linearity of the airflow in the controlled zone where it is placed for sampling should be taken into consideration [13].

## **M. Operational Evaluation of the Microbiological Status of Aseptically Filled Products in Clean Rooms and Other Controlled Environments**

The controlled environment is monitored according to an appropriate environmental monitoring program. Additional information on the evaluation of microbiological status can be obtained by the use of media fills. Media fills should be considered as a method of simulating process operations by using media, however. Therefore, the method shows not only the environmental conditions but also operation conditions, such as the operators' trained level, the belt speed, and the size (opening) of vials, which have a closer relationship with the results of media fill test. In addition, attention has to be paid to the fact that the method is less sensitive than other monitoring methods and can only detect contaminated products to a level of 0.1% of falling microbes. Most of the contamination detected by media fills are caused by process troubles such as intervention of personnel or mechanical accident rather than the environment status or air cleanliness. The media fill test is therefore appropriate for the evaluation of overall operations, but not appropriate to evaluate the environment or air cleanliness [12,13].

## **N. An Application of Technologies for Localization of Aseptic Processing**

It is easily understood that if the aseptic operation is performed in a separated small space from which personnel have been completely excluded, the necessity for room classification based on particulate and environmental microbiological monitoring requirements may be significantly reduced. In other words, critical operations in an aseptic area should be performed in the smallest space, and intervention by personnel should be minimized by indirect means through the use of protective glove ports and/or half suits. Application of these methods can minimize the chance of contamination. Following are such systems currently in place to reduce the contamination rate in aseptic processing.

### **1. Barriers**

In the context of aseptic processing systems, a barrier is a device that restricts contact between operators and the aseptic field enclosed within the barrier. Barriers may not be sterilized and do not always have transfer systems that allow the passage of materials into or out of the system without exposure to the surrounding environment. Barriers range from plastic curtains around the critical production zones to rigid enclosures found on modern aseptic-filling equipment. Barriers may also incorporate such elements as glove ports, half suits, and rapid-transfer ports.

## 2. Isolator

This technology is used for a dual purpose. One is to protect the product from contamination from the environment and/or personnel during filling and closing operation by keeping the air pressure inside the isolator positive, and the other is to protect personnel or other products from deleterious or toxic products that are being manufactured by keeping the air pressure inside the isolator negative.

Isolator technology is based on the principle of placing previously sterilized components (containers/products/closures) into a sterile environment. These components remain sterile during the whole processing operation, since no personnel or nonsterile components are brought into the isolator. The isolator barrier is an absolute barrier that does not allow for interchanges between the protected and unprotected environments. Isolators either may be physically sealed against the entry of external contamination or may be effectively sealed by the application of continuous overpressure. Manipulations of materials by personnel are done via the use of gloves, half suits, or full suits. All air entering the isolator passes through either a HEPA or an UPLA filter, and exhaust air typically exits through a HEPA-grade filter. Per-acetic acid and/or hydrogen peroxide vapor are commonly used for the surface sterilization of the isolator unit's internal environment. Since barrier systems are designed to reduce human intervention to a minimum, remote sampling systems should be used in lieu of personnel intervention. In general, once the validation establishes the effectiveness of the barrier system, the frequency of sampling to monitor the microbiological status of the aseptic processing area can be reduced, as compared to the frequency of sampling of classic aseptic processing systems.

Continuous total particulate monitoring can also provide assurance that the air filtration system within the isolator is working properly, just as in the normal environmentally controlled area [13].

## 3. Summary of Air Handling Systems Validation

1. Determination of required air quality
2. Design of total air treatment system
3. Supply of air to the room
  - a. Amount of air
  - b. Locations of air supply
  - c. Air velocity
  - d. Airflow pattern
  - e. Exchange ratio
  - f. Return ratio
  - g. Temperature and humidity
  - h. Amount of exhaust
  - i. Location of exhaust
  - j. Pressure differential among the rooms

4. Qualification of air cleanliness
  - a. Frequency of air monitoring
  - b. Location of sampling
  - c. Method of evaluation
5. Qualification of design, installation, operation, and performance, including monitoring
6. Monitoring of air quality; monitoring data should be evaluated by comparing with the protocol and summarized as a validation document
7. Corrective actions, if necessary
8. Change control
9. Maintenance

## V. THE VALIDATION REPORT

Validation reports are written at the conclusion of the equipment IQ and OQ and when process validation is completed. The reports should be stand-alone documents containing all pertinent information because they will serve as primary documentation for later FDA regulatory inspections and as reference documents when changes to the system are planned and the need for revalidation is under consideration.

Like the validation protocol, the validation report has a standard format. It begins with a brief *executive summary*, in which the major findings and recommendations are presented. All protocol deviations are identified here, along with a brief explanation of the reason for the deviation and its impact, if any, on the outcome of the validation. Next is a *discussion* section, in which all findings, conclusions, and recommendations noted in the *executive summary* are explained in detail. Topics should be presented in the order in which they appear in the protocol. Protocol deviations are fully explained and justified, and a judgment is made by a competent individual (or individuals) regarding their impact on the validation study. Data tables and attachments should be referenced as needed.

*Conclusions and recommendations* is the next section. Here, a statement is made regarding the validation status of the water or air treatment system and the possible need for additional validation studies focusing on some aspect or component of the system.

The last section of the report is a list of attachments. Because the report will be the official, complete file on the water or air treatment system validation, it must contain raw data, drawings, manuals, tables, instrument calibration reports, and a copy of the validation protocol along with any protocol addenda. The report is then endorsed and dated by designated representatives of each unit involved in the water or air treatment system validation.

## REFERENCES

1. ICH. *Good Manufacturing Practice Guide for Active Pharmaceutical Ingredients*. Q7A (March 15, 2000).
2. General information (1231): Water for pharmaceutical purposes. *U.S. Pharmacopeia*. vol. 25. Rockville, MD: U.S. Pharmacopeial Convention, pp. 2261–2270 (2002).
3. Water for injection, purified, sterile. *U.S. Pharmacopeia*. vol. 25. Rockville, MD: pp. 1809–1890 (2002).
4. Purified water, water for injection. *European Pharmacopeia*. 3rd ed. Strasbourg: European Pharmacopeia Convention, pp. 1723–1724 (1996).
5. Water for injection. *Japanese Pharmacopeia*. 14th ed. Tokyo: Hirokawa, p. D-751 (2001).
6. Meltzer, T. H. *Pharmaceutical Water Systems*. Littleton, CO: Tall Oaks, p. 683–691 (1996).
7. FDA. FDA's proposed current good manufacturing practices (GMP) for regs. for large volume parenterals (LVP). *Fed Reg* (June 1, 1976). Preliminary Concept Paper of Sterile Drug Products Produced by Aseptic Processing, draft paper, Sept. 27, 2002.
8. Carton, F. J., Agalloco, J. P., Artiss, D. H. *Validation of Aseptic Pharmaceutical Process: Water System Validation*. New York: Marcel Dekker (1996).
9. *Pharmaceutical Engineering Guide Vol. 4: Water and Steam Guide*. Tampa, FL: ISPE, (1997).
10. Code of Federal Regulation Title 21, Part 211. Current good manufacturing practice for finished pharmaceuticals (2002).
11. *Cleaning and Cleaning Validation: A Biotechnology Perspective*. Bethesda, MD: PDA (1996).
12. Kawamura, K. Scale-up, validation and manufacturing of microspheres in the “sustained release injectable products.” J. Senior and M. Radomsky, eds. Englewood, CO: InterPharm Press (2000).
13. General information <1116>: Microbiological evaluation of clean rooms and other controlled environments. *U.S. Pharmacopeia*. vol. 25. Rockville, MD: U.S. Pharmacopeial Convention, p. 2206–2212 (2002).
14. EU. GMP annex: Manufacturing of sterile products (1996).
15. Federal Standard 209E. Airborne Particulate Cleanliness Classes in Cleanroom and Clean Zone (Sept. 11, 1992).
16. *Japanese Pharmacopeia*. 14th ed. suppl. Tokyo: Hirokawa (2001).
17. *Pharmaceutical Engineering Guide Vol. 3: Sterile Manufacturing Facilities*. Tampa, FL: ISPE, (1997).
18. FDA/ISPE. *Pharmaceutical Engineering Guide*. vol. 1. Tampa, FL.
19. Classification of Airborne Particulates, in Cleanrooms and Associated Controlled Environments—Part 1, ISO 14644-1, Geneva: International Organization for Standardization (1999).
20. WHO GMP. *Good Practices in Manufacturing of Pharmaceutical Products in WHO Expert Committee on Specifications for Pharmaceutical Preparations, 32 edition*, Geneva (1992).

# 13

## Equipment and Facility Qualification

**Thomas L. Peither**

*PECON—Peither Consulting, Schopfheim, Germany*

### I. INTRODUCTION

The importance of the qualification process of technical systems in the pharmaceutical industry has been steadily increasing over the last 10 years. It has been driven primarily by the requirements of regulatory bodies and not by the need to save money in this part of the industry. If the industry made use of the full scope of the GMP requirements, the qualification process would be more efficient and the cost of qualification would drop. On the other hand, pharmaceutical companies want to protect themselves from a less than perfect result during a regulatory inspection and therefore demand 120% effort from their suppliers and service companies. New methods and tools must be implemented to reach the goal of qualifying a technical system while minimizing effort.

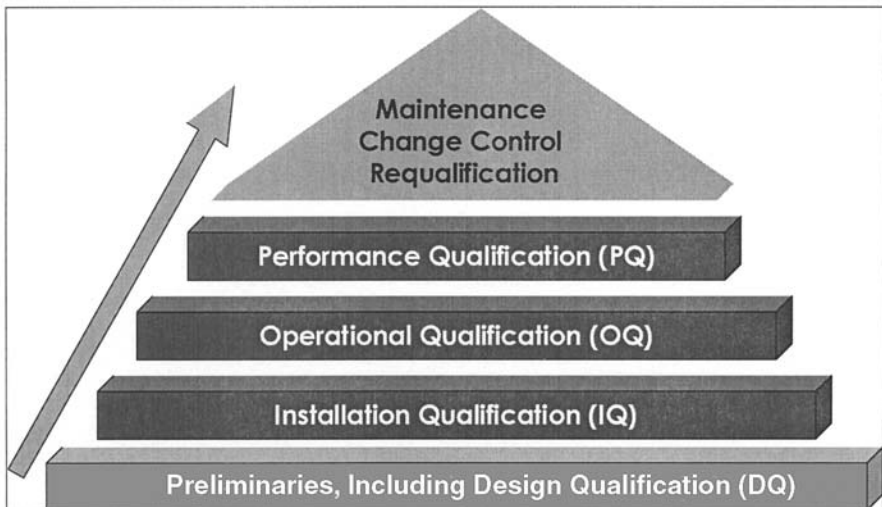
Another aspect is the trend for quality assurance departments to evolve from being mere controllers of product quality to delivering tools and methods to other departments, thus helping them to design a better production process. The goal is to improve overall production reliability and availability. In order to achieve this objective, the quality assurance team must be experienced in applying and teaching the qualification tools and methods needed. This is a trend that has not yet started in many companies. It may be seen in other industries that more instruments and quality tools are necessary than those limited to qualification and validation. Qualification and validation only appear to be the beginning of a continuous development process in the quality assurance of the pharmaceutical industry.

To avoid misunderstanding, it is crucial to use the correct terms and expressions during quality management. A list of definitions can be found in the appropriate section.

The following describes how the qualification of pharmaceutical equipment and facilities can be efficiently planned and executed.

Figure 1 depicts the most commonly used approach to the qualification process as used in the pharmaceutical industry. It shows a pyramid, which is the best way in which to plan a qualification/validation project. Investing more time in the first phases will save time and money in later and critical phases. If inadequate investment is made during the start-up of a project, the later phases of installation qualification (IQ), operational qualification (OQ), and performance qualification (PQ) will necessarily require an inordinate amount of time and money. The project will be a pyramid again, but now it is inverted.

It must be stressed that a good engineering and project process is the best basis for proper qualification and validation work. It is the current opinion on qualification in the pharmaceutical industry that the later steps in the qualification process need more time and attention than the earlier steps. This may be totally different in other industry branches; they tend to spend more effort during the earlier stages to save time and money later on.



**Figure 1** Steps of qualification.



If the pharmaceutical industry adopted the lessons learned in other branches (e.g., aircraft industry, automotive industry) it could realize an increased efficiency in the qualification and validation processes. To this end effort should be made to investigate statistical process control (SPC), house of quality, Deming circuits, and so on.

At the moment the term design qualification (DQ) is the focus of some controversy. Performing a DQ is not a legal requirement, but it has been introduced to the qualification process through implementation of Annex 15 to the *EC Guide on Good Manufacturing Practices for Medical Products*. It is not a requirement to implement a DQ, but it seems that regulatory bodies have an interest in promoting this element of engineering and quality management. It should be a requirement of a proper engineering process, and in fact although it is often a part of the engineering process, it is not declared as a separate action. Nevertheless, the activity itself should be executed in combination with an efficient procedure documented in a standard operating procedure (SOP). (See Sec. V.) Important aspects that should be taken into consideration before qualification aspects start are shown in Figure 2.

It is important to perform these preliminary steps conscientiously. Most qualification projects fail because these basic activities are not performed adequately.

- **Project Management**  
It is important to have detailed procedures, how the project is organized, and how the project is controlled
  - **Project Organization**
  - **Meeting Management**
  - **Project Planning**
  - **Project Reporting**
  - **Project Management Software**
- **Equipment and Facility Master Plan**  
An overview of the project with all relevant qualification activities
- **User Requirement Specification**  
Basic document that is the root for all qualification and validation activities
- **Design Qualification/Risk Analysis**  
Investigation of a technical system concerning fulfilling the GMP requirements

**Figure 2** Preliminary steps.

## **II. PROJECT MANAGEMENT**

Good project management is the first step toward organizing the successful qualification of a technical system. A well-structured and -planned approach to qualification is the first step toward success.

The tools and methods of project management are mainly used for large and complex projects. It is equally important to apply these management skills to smaller projects, however. A good project start is the best way to win the battle.

### **A. Project Organization**

To start with, the project organization must be defined. The different positions must be defined and people need to be found with the necessary knowledge to fill these positions. The most commonly required areas of expertise for a project leader are organizational know-how, social skills, project management know-how, time management, validation know-how, and general technical know-how. A team member should have expertise in communication skills, validation know-how, and detailed technical know-how.

### **B. Meeting Management**

The communication structure must be defined following the definition of the best project organization. A lot of projects waste time in meetings. Everybody is familiar with this scenario. You find yourself sitting in a meeting thinking that your time is being wasted and that you might not attend another scheduled meeting. Nobody likes to feel that his or her time is wasted, therefore thorough planning prior to any meeting is mandatory.

A chairperson heading the meeting must be chosen and a person designated to take the minutes. Every meeting should have an agenda. People should be invited based on whether or not they can help with solving the issues on the agenda. Obviously everyone attending should be well prepared. In order to facilitate this process, meetings should be planned 6 months in advance.

### **C. Project Planning**

After the definition of functions, responsibilities, and communication structures, the project itself must be planned. Using Gantt charts is often the best way to schedule the different tasks. This allows you to see quickly which task has to be done when and by whom. The charts also indicate interdependencies between different tasks and show what happens if a task takes longer than planned. Dif-

ferent software is available to help generate such project plans. An example for a project plan is shown in [Figure 3](#).

People often ask for an example of a detailed project plan. Working out a specific project plan requires in-depth knowledge of a technical system, however. As each system is different, Figure 3 can only show a general overview of a project plan.

#### **D. Project Reporting**

The next important task in the process of project management is the implementation of efficient project control. A reporting system must be put into place that describes the current state of the project as well as the progress of the most important tasks. Additionally, the reporting system must be able to pick up and highlight problems within the project. A functioning reporting system is the controlling instrument for the project manager.

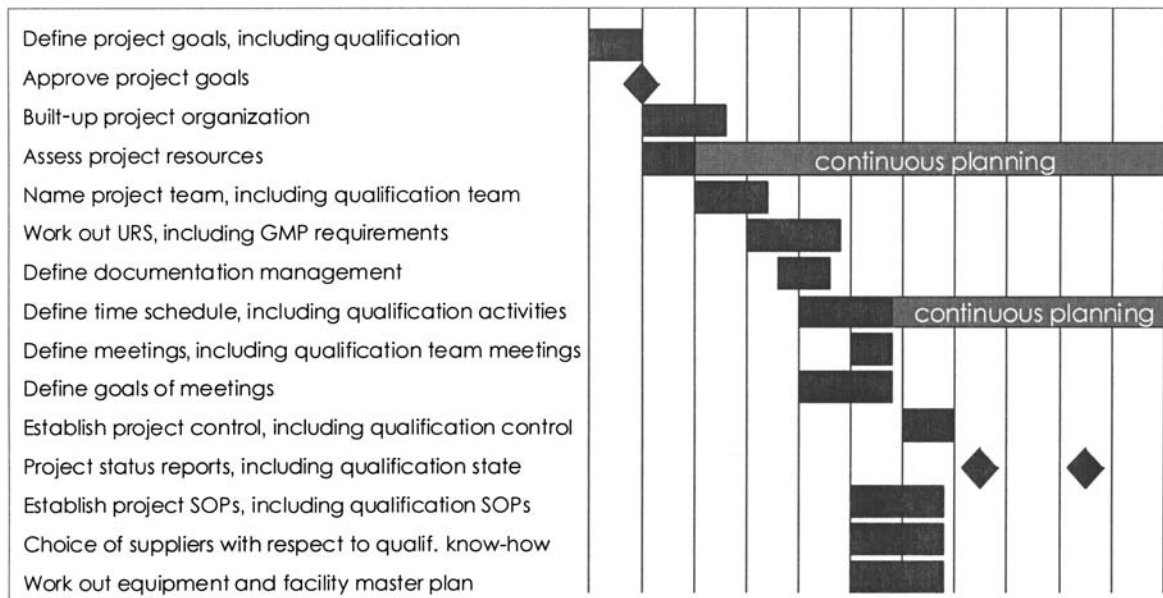
#### **E. Tools for Project Management**

In order to manage a project efficiently appropriate tools must be applied. There are several products of project management software on the market. The decision as to which system is the best suited for a given project should include the following aspects:

- Project focus
- Size of a project
- Number of team members
- Number of tasks in a project
- Required functionality

### **III. VALIDATION/QUALIFICATION MASTER PLAN**

It is important to draw up a summarized document that describes the whole project. It has become common practice in the industry to develop a “validation master plan” (VMP). This document would usually include the qualification aspects of a project. Alternatively, a “qualification master plan” (QMP) should be drafted. In case of a large retrospective qualification project it is beneficial to write a separate QMP. The main point is to develop a document that includes the most important information of the project and can be used like a project handbook.



**Figure 3** Project plan.

# Equipment and Facility Master Plan

- **Introduction**  
Firm's validation policy, general description.
- **Organizational structures**  
Description of personal responsibility for all validation activities.
- **Plant, process, and product description**  
Make a brief description of the plant, process, and product or reference to adequate documents.
- **Specific process consideration**  
Outline specific characteristics of the plant, process, etc. that are critical for yielding a quality product and need extra attention.
- **List of products, processes, systems to be validated**  
All validation activities should be summarized and compiled in a matrix format.
- **Key acceptance criteria**  
General statement on acceptance criteria for all systems that are listed in the validation matrix.
- **Documentation format**  
The format used for protocols and reports should be described or referred to.
- **Required SOPs**  
A list of relevant SOPs should be presented.
- **Planning and scheduling**  
Describe the estimated resources for staffing, equipment, and other specific requirements, including a time plan of the project.
- **Change control**  
Include a description or reference to controlling critical changes to materials, facilities, equipment, or processes.

**Figure 4** Structure of a validation master plan.

## A. Structure of a VMP or QMP

The structure of a VMP or QMP is well documented in the PIC/S document PI 006 *Recommendation on Validation Master Plan, Installation and Operational Qualification, Non-Sterile Process Validation and Cleaning Validation*. This document is the basis for Annex 15 to the *EC Guide on Good Manufacturing Practices for Medical Products*. Figure 4 displays the most commonly used topics to be described in a VMP.

The PIC/S-document PI 006 defined the VMP as “A document providing information on the company’s validation work programme. It should define details of and time scale for the validation work to be performed. Responsibilities relating to the plan should be stated.” The *EC Guide on Good Manufacturing Practices for Medical Products*, Annex 15, said of the VMP: “All validation activities should be planned. The key elements of a validation programme should be clearly defined and documented in a validation master plan (VMP) or equivalent documents. The VMP should be a summary document which is brief, concise and clear.” The FDA published another interesting paper in 1995,

the *Guide to Inspections of Validation Documentation*. This guide outlines the basics in qualification and validation; for example, “Planning documents may use various formats and styles, and different descriptive terms may be used such as master validation plan, project plans, study plans, and others. Regardless of terminology, it is important that suitable documents denote intentions in sufficient detail.” It highlights the benefits of having an overall document such as VMP.

To summarize, the VMP or QMP should be a brief overview of the project, tasks, tools, resources, and methods that are going to be used during the project. This document should be described at a very early stage of a project by the engineering or manufacturing department of a pharmaceutical manufacturer or service provider.

Standard operating procedures are an integral part of any VMP or QMP. They outline rules that have to be followed during the project and provide project members with guidelines as to which rules have to be studied before starting work.

## **B. Areas of Interest**

Many technical systems in a pharmaceutical production have to be validated or qualified. The requirement for a system to be validated depends on its impact on product quality. Whether a system is critical or not may be determined through a risk analysis. (See Design Qualification.) Following is a list of such different systems or clusters of systems.

### **1. Infrastructure and Facilities**

- High purity water systems (high purity water, water for injection, highly purified water, etc.)

- Clean steam

- Gases with product contact (compressed air, nitrogen, oxygen, vacuum, etc.)

- HVAC with rooms (clean area), including lighting

### **2. Equipment**

- Closures, tanks, vessels with product contact

- Machines with product contact (filling machine, washing machine, closing machine, granulator, packaging lines, etc.)

- Machines with direct impact on product quality (autoclaves, sterilizing units, labeling system, weighing system, production control system, facility control system, etc.)

## IV. USER REQUIREMENT SPECIFICATION

The goal of working out user requirement specifications (URS; Fig. 5) is to document the needs of the manufacturing department. User requirement specifications are always written for a technical system that should be implemented in the production process of a pharmaceutical product. The URS is very important for realizing a project, as many measurements refer to the URS. A well-prepared URS is the key to a project's success. Projects without detailed URS have a tendency to demand lots of change later on, thus increasing cost, start-up times, or both. Who should evaluate a URS? Best practice is a coordinated approach among production, quality assurance, and engineering of the pharmaceutical company. Some companies even use the services of external resources to create a URS.

### A. GMP Requirements

The key aspect of any URS is to generate a document detailing all the GMP requirements the technical system has to fulfill. The URS is an important document for the commissioning phase as well. Often the URS provides the basis for an offer to the suppliers. A detailed URS will result in a better and more competitive offer for the technical system. While evaluating a supplier, it is important to gather as much information as possible. Without a comprehensive URS, a pharmaceutical company cannot get a clear understanding of the supplier and may be led to make a wrong decision.

- **Cover sheet**  
Reference with numbering system, date, and signature of author, approvals with sign and date of user, engineering, and QA.
- **Scope**  
General intention of URS and introduction of the focused system, interface to project.
- **System description**  
Brief description of the system; description of the system boundaries; naming the product produced with the system; outlining of important technical aspects.
- **Positioning requirements**  
What requirements the system has concerning location and interfaces to other systems.
- **Definition of system specification**  
Description of all important and critical specifications of the system, like process parameter, technical parameters, safety requirements, environmental requirements, and GMP-relevant specifications.
- **Regulatory documents**  
Reference all relevant regulatory documents that are important for implementing the system.

**Figure 5** Content user requirement specification (URS) design qualification.

## **B. Technical and Economic Requirements**

User requirement specifications cover more aspects than only the GMP requirement, because the URS is not written only for the validation procedure; in fact, a URS is a very important project document covering technical as well as economic requirements of the technical system. Pharmaceutical manufacturing departments not only check the GMP aspects of a system; additionally, following good engineering practice they will review the technical and economic aspects of a technical system. Obviously, the more experience a company gains, the more comprehensive a URS become. Past experiences such as project faults, inefficient technical systems, and bad commissioning can be included in a URS.

## **V. DESIGN QUALIFICATION (DQ)**

Design qualification is more common in Europe than in the United States. There is no legal requirement to perform a DQ. Sometimes this phase may not be called DQ, but may instead be referred to as “design review,” “design assessment,” and so on. The intention is important in this phase. The goal is to perform something similar to a risk analysis and to check the design documents of a technical system to ensure that they fulfill the user requirements. For this reason a risk analysis—not yet commonly known in all companies—should be used.

### **A. Risk Analysis**

The overall concept of all of the following tools is that of risk analysis or risk assessment. Risk analysis helps to decide whether an aspect is GMP-critical or not. The risk analysis can be performed in a formal or more informal way. Following are two popular and import types of risk analysis. Another method, the fault tree analysis (FTA), has recently been used in the area of computer validation. This method is not described here, as it is a complex form of risk analysis.

### **B. FMEA**

FMEA is a quantitative risk analysis for complex systems (Fig. 6). As this approach involves assessment of occurrence probabilities, detection of failures, and judgment as to the severity of a failure, it should only be chosen if some practical experience with the technical system is available. Each of the three values will be assigned a number from 1 to 5. Multiplying these values results in the “risk priority number.” This number indicates the priority of the assessed failure. The pure version of the FMEA is seldom practiced in the pharmaceutical industry.



- **Is the system a critical system?**  
In the first step it must be determined, whether the system is a GMP-critical system or not. If not, a GMP-FMEA is not necessary.
- **Potential failures must be found**  
The goal of a GMP-FMEA is to rate all potential GMP risks of a system. For that it is important to find all potential failures. The potential failures should be clustered.
- **Cause and effect must be documented**  
The basic cause and resulting effects of a failure should be documented
- **Assessment of the GMP risk**  
Every GMP risk with cause, failure, and effect will be rated with the aspects probability of occurrence (O), probability of detection (D), and severity of the effects (S)
- **Risk priority number (RPN)**  
The aspects O, D, and S will be rated with values from 1-5. After that the RPN can be calculated by multiplying the three values.
- **Take measures**  
If the RPN is higher than a predefined threshold, there must be defined measures to reduce the level of the risk. The goal is to reduce all the GMP risks to a passable level (measures can be, e.g. IQ/OQ for a function or subsystem, additional in-process-control, redesign of a technical system)
- **Documentation**  
All decisions that are made in the FMEA must be documented and a final report should be written and approved by the user, the engineering department, and the QA.

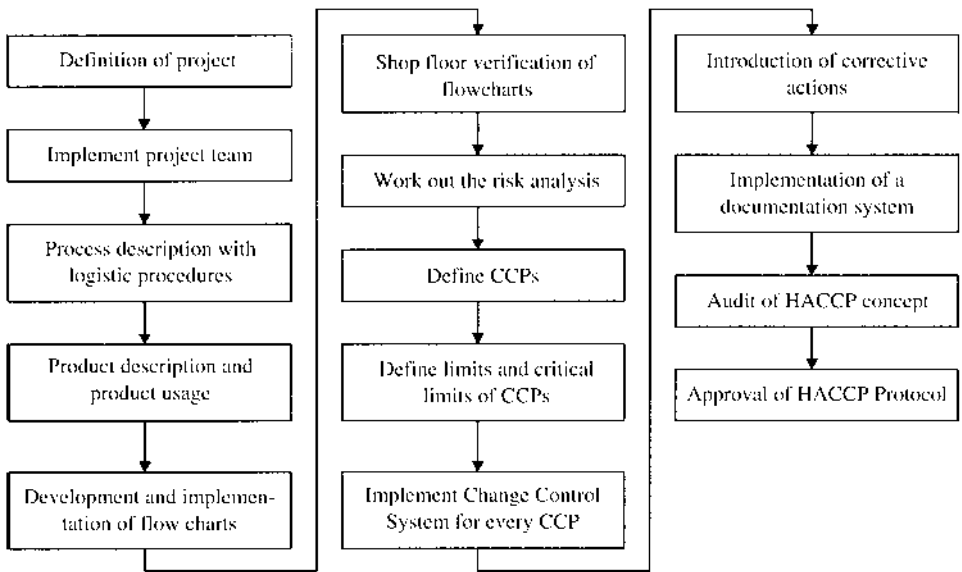
**Figure 6** Failure mode and effects analysis (FMEA) overview.

Most common risk analysis forms are mutations of the fundamental FMEA. It is easier for most companies to start initially with a more practical way of performing a risk analysis. In the future the fundamental FMEA will be more commonly applied, as companies will have gained confidence with variations of the FMEA.

Variations are often made by cutting the detection of failures or severity of failures. Sometimes the values are decreased to a spread of 1 to 3. In other cases the risk priority number is not calculated, but the levels are noted in a matrix to see whether the point is critical or not.

### **C. Hazard Analysis of Critical Control Points (HACCP)**

The second method is the hazard analysis of critical control points (HACCP; Fig. 7). This method is well known in the food industry. The goal of HACCP is to reduce the risk of contamination of products and to reduce the effort for testing products during final tests. The HACCP defines critical control points (CCPs) in different grades (usually three grades). The HACCP protocols are



**Figure 7** Hazard analysis of critical control points (HACCP).

worked out and the results are documented in reports. Important steps are the definition of CCPs and their limits, the implementation of a change control system, the execution of corrective actions, and the implementation of a documentation system. Equally important are regular audits of the concept and the approval of HACCP protocols using appropriate procedures. As with the FMEA, the HACCP concept offers the opportunity to rethink all technical and organizational aspects in an early phase of a project and to find out all critical deficiencies.

#### **D. Documentation of DQ**

The results of any risk analysis should be well documented as they become the key input into the qualification and validation process. They are the basis for defining tests in the IQ, OQ, and PQ phases. It is often impossible to say prior to a risk analysis what steps of qualification need to be performed. It depends on the risks and measurements defined during the risk analysis. Equally important, this procedure increases the efficiency of the qualification process. In the past, the decision on which qualification tests to perform was outlined by writing qualification protocols. These usually prompted long and expensive discus-

sions. One of the challenges is to determine which parts of a system to devise tests for. It is easy to imagine that companies and people who have experience with risk analysis are in a better position, as they will have developed standard tests for a list of critical elements, leaving only a few additional tests to be designed for a particular system. The result is that the longer the qualification system is in place the more effective it becomes. This is a great advantage and helps to repay the investments of starting a risk analysis system quickly.

## VI. INSTALLATION QUALIFICATION

The decision as to which system needs to be qualified should result directly from the risk analysis process and should be described in the VMP or QMP. In any case, it would be a technical system that impacts on the quality of a pharmaceutical product. Installation qualification aims to check documentation against reality. The result is “as-built documentation.” The other task in the IQ is to ensure that the GMP requirements are fulfilled. The generally accepted way to perform an IQ is to

- Develop an IQ protocol (Fig. 8)

- Approve the IQ protocols (by the quality assurance, production, and technical departments)

- Perform the IQ

- Work out the IQ report

- Approve the IQ report (by the quality assurance, production, and technical departments)

Installation qualification is defined in the PIC/S document PI 006 as “The performance and documentation of tests to ensure that equipment (such as machines, measuring equipment) used in a manufacturing process, are appropriately selected, correctly installed and work in accordance with established specifications.”

The OQ phase relies on valid calibration of all quality-relevant instruments. The best way to guarantee this is to perform the calibration at the end of the IQ phase. Sometimes it is performed at the beginning of the OQ. This procedure is acceptable as well.

The IQ phase will be executed with personnel of the supplier of a technical system or with technical personnel of the pharmaceutical company. It will follow the procedures set out in the IQ protocols. After performing the IQ, the results are summarized and documented in an IQ report.

The qualification of the control unit of a technical system is very similar to that of the mechanical equipment of a system. This does not apply to compu-

**Name of the System**

*Qualification Number*

**IQ-No. IQ 1**

<b>Goal:</b>
Documentation of: a) Owners' Manual b) Service and Maintenance  The processes listed above must be described in approved documents.

<b>Test description:</b>
Visual control to ensure that documents are filed according to SOP 3-24-123. Check that the supplier service advice has been incorporated in the maintenance protocol.

<b>Acceptance Criteria:</b>
The document is filed correctly as described by SOP 3-24-123.

<b>Actual value:</b>
The processes are documented in the following documents.
OK    not OK
a) Owners Manual
File:                      Register: <input type="checkbox"/> <input type="checkbox"/>
b) Service and Maintenance
File:                      Register: <input type="checkbox"/> <input type="checkbox"/>
The maintenance protocol includes the supplier service advice

Result:	<input type="checkbox"/> accepted <input type="checkbox"/> not accepted (describe necessary action to be taken)
---------	--

Action/Comment:	
-----------------	--

**Figure 8** Example of an IQ protocol.

**Name of the System**

*Qualification Number*

**IQ-No. IQ 1**

Author of protocol	Date	Signature
Approval of action taken	Date	Signature
Person in charge of execution	Date	Signature
Approval of results	Date	Signature

**Figure 8** Continued.

terized systems, however. These are described in detail in another part of this book.

The most important aspects to consider during IQ are

- Provide as-built documentation (e.g., P&ID check).
- Check training reports.
- Check that documentation is complete.
- Check calibration reports.
- Identify piping and instrumentation

**VII. OPERATIONAL QUALIFICATIONS**

Operational qualification is defined in the PIC/S document PI 006 as “Documented verification that the system or sub-system performs as intended throughout all anticipated operating ranges.”

Operational qualification tests whether or not the system works as expected. The approach to a successful OQ is the same as described for IQ [develop OQ protocols (Fig. 9)], approve OQ protocols (by the quality assurance, production, and technical departments), perform OQ, work out OQ report, and approve OQ report (by the quality assurance, production, and technical departments).

The OQ phase normally involves personnel from the supplier of a technical system or technical personnel from the pharmaceutical company. It is prefer-

Company

OPERATIONAL QUALIFICATION PROTOCOL	
Date : date of writing the protocol	Page :x (y)
System : name of the system	
Type : ./.	
Supplier : name of supplier	
Location : exact address	
Author:	Approval:

**QO-Test No. x**

---

**Aspect/Subsystem**

**Acceptance Criteria**

**Description of Execution**

**Necessary Documentation**

**Documentation of Actual Values**

Checkpoint	OK/not OK	Date	Signature

**Comment / Remark / Corrective Actions:**

**Figure 9** Example of an OQ protocol.

able to include customer employees, as they are going to be the users of the system. This facilitates a better know-how transfer between supplier and customer. Again, this process follows the rules outlined in the OQ protocols. The results of OQ are summarized and documented in an OQ report. It is commonly accepted practice in the industry to produce one report for both IQ and OQ results. This saves money and time for approval.

Operational qualification of the control unit of a technical system is one of the most important steps during the OQ phase. It tests all critical functions and alarms of the technical system. There are no different procedures for mechanical OQ and control unit OQ.

The result of the OQ is a documented approval that the technical system fulfills the user requirements and all GMP-related functions of the technical system.

Typical tests in the OQ include the following:

Alarm tests

Behavior of the system after energy breakdown

Accuracy of filling lines

Transportation speed in a sterilization tunnel

Temperature distribution in an autoclave

Performance of a washing machine

Accuracy of a weighing system

## VIII. PERFORMANCE QUALIFICATION

The PQ is the phase in which either a technical system is tested over a long period of time (e.g., water system), or a complex technical system is tested overall (connected filling line). For many systems OQ is the last phase performed during qualification. If there are only a few performance tests needed, it might be more practical to include them during OQ or process validation. Combining OQ and PQ decreases the number of documents (less documentation work in the future) and cuts approval time and effort. Again, the procedure for PQ is the same as for IQ and OQ ([develop PQ protocols, approve PQ protocols (by the quality assurance, production, and technical departments), perform PQ, work out the PQ report, and approve the PQ report (by the quality assurance, production, and technical departments)]. The documentation and test description are identical to those in the OQ phase.

Performance qualification should be executed by customer personnel. It is a great disadvantage if it has to be performed by the supplier. Ideally this phase allows know-how to be established at the pharmaceutical company.

The following technical systems need to be performance-tested and qualified:

High purity water systems (monitoring of the quality parameters: pH, TOC, conductivity, CPU, temperature)  
 HVAC systems (temperature, pressure, humidity)  
 Complex connected systems (e.g., filling line, BPI production line; performance parameters)

## IX. DOCUMENTATION SYSTEM

To quickly locate any given document, it is mandatory to have implemented an appropriate documentation system. In case of a fault in production or inspection, it becomes necessary to find a document within 15 to 20 min. All companies should test the reliability of their documentation system using internal audits.

One aspect of a working documentation system is a standardized documentation structure. If every system is documented using the same document structure, everyone can gain access to the necessary information quickly. Figure 10 shows an example of a documentation structure.

Documents do not need to be delivered to the customer in paper format. Electronic media documents such as CDs are equally acceptable. Obviously, an appropriate reading system must be in place to access the documents at a later date (e.g., for an inspection). Such a system must remain in place until the

- **Conceptual Design**
  - User Requirement Specification
  - Authority applications
  - Qualification Protocol
  - Calculations
  - Design Documents
  - Order
  - Project Documents
- **System Description**
  - Technical Drawings
  - Parts List
  - Software
  - Description
- **Production/Installation**
  - Foundation Plan
  - Assembly Plan
  - Mounting Instruction
- **Operation**
  - Training
  - List of Spare Parts
  - Working Instructions
  - Maintenance
  - Changes
  - Legal Tests
- **Interfaces to Technical Systems**
- **Qualification**
  - Design Qualification
  - Installation Qualification
  - Operational Qualification
  - Performance Qualification
  - Qualification Report
- **Scrapping of the system**

**Figure 10** Documentation structure.



documentation is destroyed. In case of a complete electronic documentation system the whole system needs to be validated by computer validation.

## X. CHANGE CONTROL

Change control is defined in the PIC/S document PI 006 as follows: “A formal system by which qualified representatives of appropriate disciplines review proposed or actual changes that might affect a validated status. The intent is to determine the need for action that would ensure and document that the system is maintained in a validated state.”

Change control is a lifetime monitoring approach. Planning for well-executed change control procedures (Fig. 11) includes the following aspects:

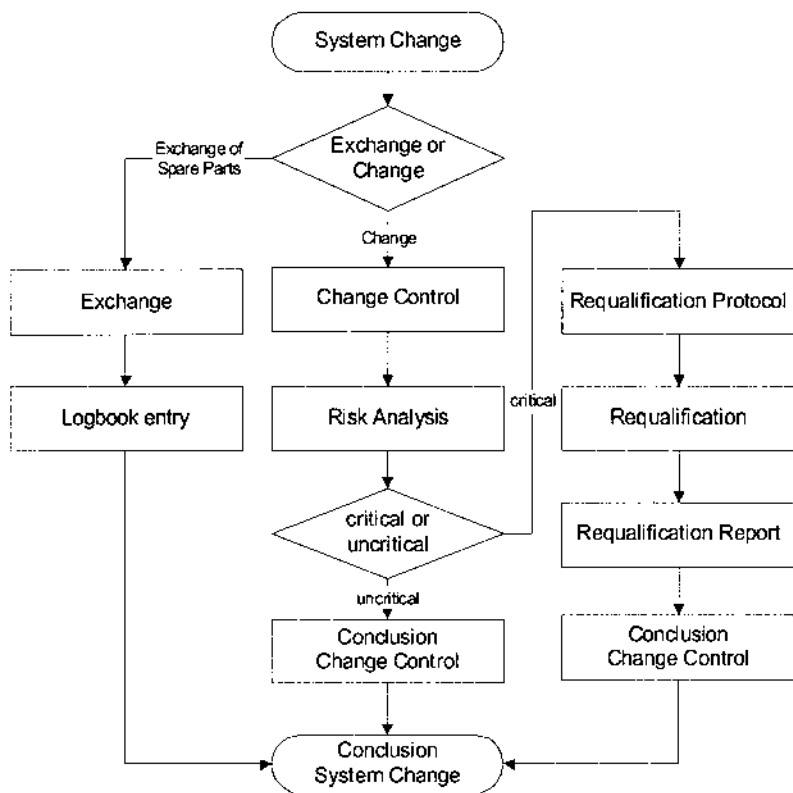


Figure 11 Change control procedure flowchart.

Workable documentation system  
Defined responsibilities and job descriptions  
Defined review procedures  
Well-trained staff

The implementation of a change control system is an important and necessary step in the validation approach for equipment and facilities. Vital to any change control system is its efficiency in that it does not require too much time and effort to handle changes. In order to design an efficient change control system, the following aspects need to be taken into consideration:

Early categorization of a change as major or minor change (i.e., catalogue). This should speed up the decision and approval time of a change.

Easy and logical way of document flow (production engineering, quality assurance, production).

Easy and logical decision tree for major or minor changes or planned or emergency changes.

It is not only good practice but also essential that a requested change is only implemented *after* the appropriate change control procedures and approvals have been followed. Time and money are often wasted because a change was not correctly evaluated (major or minor) or personnel was not familiar with the best practice for change control procedures. It is crucial for an efficient change control process that the production, engineering, and validation departments are working together very closely.

Clear change control procedures have to be in place for all eventualities. This must include instructions for situations in which the supervisory or management personnel is not present when the problem occurs. In such a case, for example, a change or correction might be implemented quickly by the maintenance or operational personnel that must then be reviewed and approved by management within 24 hr.

## REFERENCES

1. U.S. Food and Drug Administration. 21 CFR 210/211 Good Manufacturing Practice. *Fed Reg* (2001).
2. U.S. Food and Drug Administration. *Guide to Inspection of Validation Documentation* (1995).
3. *Recommendation on Validation Master Plan, Installation and Operational Qualification, Non-Sterile Process Validation and Cleaning Validation*, Pharmaceutical Inspection Co-Operation Scheme PIC/S PI 006 (2002).

4. EC. *Guide on Good Manufacturing Practices for Medical Products*. EU (2001).
5. U.S. Food and Drug Administration. *Guide to Inspection of Process Validation* (1987).
6. The gold sheet. *F-D-C Rep 34* (2000).
7. Vina, B. *GMP Compliance, Productivity, and Quality*. Interpharm Press (1998).
8. ISPE. Baseline® Pharmaceutical engineering guide series: Introduction of commissioning and qualification. ISPE 2000 European seminar, Amsterdam, 2000.

# 14

## Validation and Verification of Cleaning Processes

**William E. Hall**

*Hall & Pharmaceutical Associates, Inc., Kure Beach, North Carolina, U.S.A.*

### I. INTRODUCTION

The cleaning processes used in pharmaceutical operations have achieved an increasing emphasis in the past decade both by the regulatory agencies and industry itself. At this time it is generally regarded as just as critical to have effective cleaning processes as to have consistent, validated manufacturing processes. Several developments have caused this emphasis on the cleaning process. First, the new generation of products (as well as those in the current “pipeline”) tend to be more potent (e.g., many are potent in mg and sub-mg doses). Second, a series of tragic contaminations occurred over the last several years that led to serious personal injury. In addition, we know that many individuals are sensitive to various drugs and that these sensitivities, often described as allergenicities, can be very serious.

The reader will note that the title of this chapter includes a second term in addition to the more familiar term “validation.” True classic validation of the cleaning process is not always possible in certain pharmaceutical operations, and verification is a more appropriate description of the approach to cleaning. The application of this concept to research and development (R&D) areas will be developed and discussed in this chapter.

The basic reason for having good, effective, consistent cleaning procedures is to prevent the contamination of products made subsequently in the same equipment. The goal is to provide pharmaceutical products of the highest quality to our patients. This is the basic regulatory requirement as well as the goal of all of those suppliers of products and services.

## **II. CONTAMINATION DEFINED**

Based on this premise (i.e., that we want to minimize contamination of our products) it is beneficial to begin the subject of cleaning with a description of how products become contaminated and a brief description of some potential contaminants. A simplistic starting point is to define adulteration (i.e., the state of contamination) as the condition in which the product contains a material not intended to be present and not listed in the current formulation as an ingredient. This broad definition of a contaminant is necessary because products may become contaminated with many materials. Most of us conjure up images of active ingredients from a product carrying over to another product as our primary thought of contamination. Indeed, this occurrence is important and can lead to serious medical consequences for the patient and economic consequences for the supplier of the contaminated product, device, or service. We normally refer to this contamination by carryover of active ingredients as cross-contamination. There are many other types of contamination that can also lead to serious contaminations, however. There is an old saying that “anything that can get into a product will.” Unfortunately, this is quite true.

## **III. MECHANISMS OF CONTAMINATION**

### **A. Cross-Contamination with Active Ingredients**

One of the real dangers in cross-contamination of active ingredients is that by being contaminated the product becomes truly a multiple ingredient product instead of a single active ingredient. Depending on medical effects, the contaminant may enhance the action of the intended active (referred to as having a synergistic effect); the contaminant may negate the action of the intended active (referred to as having an antagonist effect); or the contaminant may have an entirely different medical effect. In addition, the contaminant brings with it a new additional set of side effects. Imagine, if you will, the following scene occurring in a doctor’s office. Mrs. Jones has brought 2-year-old Susie in to see the doctor because of extreme rash, watery eyes, sneezing, difficulty in breathing, and a general feeling of malaise as a result of not having slept very much the last few nights. In the course of discussion, it is learned that Susie’s mother started giving her a new multiple vitamin product a few days earlier. The doctor is not aware of the fact that the vitamin product was cross-contaminated during the manufacturing process with a powerful systemic allergen. In other words, the doctor knows what is on the label of the product but he or she cannot be aware of the contaminant, which is certainly not going to be on the label. What recourse does the physician have but to treat the patient symptomatically?

## **B. Microbiological Contamination**

Another equally serious potential type of contamination is that which results from microbial contamination. This form of contamination is particularly insidious because the contamination may develop at any time, even after cleaning that was effective in removing chemical product residues. A major contributing factor is the storage of equipment in a wet condition. This provides a natural medium in which bacteria can grow. Although we have tended to identify and control microbial contamination for sterile manufacturing situations by monitoring bioburden and endotoxin levels and by environmental monitoring programs, we may not yet have given adequate attention to potential microbial contamination in nonsterile areas. Certain nonsterile products contain natural proteins or sugars that will act as a medium for bacterial growth. The net effect could be to simply cause products to have physical or cosmetic effects, or it could cause illness to the patient, depending on how the product is administered (route of administration) and the extent of microbial contamination.

## **C. Contamination by Cleaning or Sanitizing Agents**

Some pharmaceutical operations may find it necessary to use fairly toxic materials for cleaning purposes for stubborn residues. This is particularly true in the manufacture of active pharmaceutical ingredients (APIs). As such, these materials represent a potential threat as contaminants. This possibility also places a greater emphasis on effective cleaning processes. To put this in perspective, most pharmaceutical operations are using cleaning agents that have very low levels of toxicity. It seems obvious that one effective way of dealing with this potential problem is to use cleaning agents with the lowest toxicity that will still be effective in removing the residue in the given cleaning situation. As a follow-up thought, it should be noted that organic solvents are also considered to be cleaning agents when they are not part of the formulation or reaction media. In this regard, the *U.S. v. Barr Labs* court case [1] established the legal precedent that a company must prove or validate the removal of cleaning agent from equipment in a similar fashion to the removal of product residues. It follows that if a company uses an organic solvent for cleaning or sanitation purposes, it must prove that the cleaning agent or sanitizing agent is subsequently removed prior to the next manufacturing event.

The same factors also apply to sanitizing agents used to wipe down cleaned equipment. For example, it is a quite common practice to wipe down equipment used to manufacture nonsterile pharmaceuticals with isopropyl alcohol (IPA) subsequent to cleaning the equipment. This final IPA wipedown can be a source of contamination if the IPA is not subsequently removed. Although IPA is fairly volatile, it can “pool” in the intricate surfaces of a closed

system or can selectively be adsorbed into plastic, membranes, and other porous surfaces.

#### **D. Contamination by Miscellaneous Other Materials**

In addition to the usual expected or anticipated list of potential contaminants in a pharmaceutical operation, many other less likely materials can and do contaminate products. A partial list includes equipment parts such as excipients, bristles from brushes used in packaging filling equipment, paper filters, micron filters, gowning material, fibers and rubber particles from gloves, cleaning aids such as brush bristles, cloth, and cotton fibers from rags and wiping materials, lubricants, fragments from gaskets and seals, fibers from swab testing kits, and dust and particulates. The list is endless. Although one might argue that these materials are generally fairly inert, they may or may not be harmless, depending on the nature of the product. In any event, it is safe to state that the presence of these materials has led to countless rejections and recalls over the years and continues to be a quality issue.

### **IV. FACILITY AND EQUIPMENT CLASSIFICATION REGARDING CONTAMINATION RISK**

As a simple rule of thumb, the more operations carried out in a given facility or in a given piece of equipment, the more complicated the cleaning situation becomes, and the potential for contamination increases geometrically. Thus, if we want to minimize risk and the occurrence of cross-contamination it would behoove us to manufacture pharmaceutical products in a dedicated facility. This principle is already required by regulations that dictate that very allergenic substances such as penicillin and cephalosporins be manufactured in dedicated facilities [2]. Certain cytotoxic and biotechnology products are also prime candidates for dedicated manufacturing facilities.

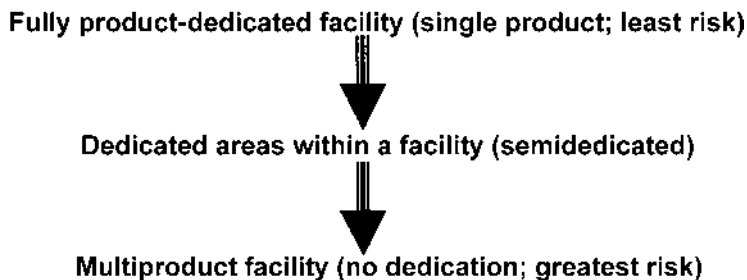
Moving up the conundrum of risk, the next most conservative manufacturing arrangement would be to have dedicated areas or suites within a given facility, with each area dedicated to a specific group of products. This would represent a "semidedicated" facility approach. For this situation, areas of the facility would be dedicated to a family of products, but any one of the family could be manufactured on any given equipment in the particular area. For example, there may be two areas, one designated as the toxic suite and the other as the nontoxic suite. Let's assume that we have three equipment trains in each suite, designated as T1T, T2T, T3T, T1N, T2N, and T3N, respectively. Suppose further that the company manufactures five toxic products and 10 nontoxic products. This would mean that any of the five toxic products could be manufactured in any

of the three equipment trains dedicated to the manufacture of toxic products (i.e., T1T, T2T or T3T). Likewise, the 10 nontoxic products could be manufactured in any of the three trains in the nontoxic suite (designated as T1N, T2N, or T3N).

The important point to grasp is that we are gradually moving through a spectrum from total dedication to semidedication and ultimately to multiproduct manufacturing situations. The multiproduct situation would be represented by manufacturing any of the 15 products in any of the equipment trains (i.e., T1T, T2T, T3T, T1N, T2N, or T3N). It is important to realize that as the degree or extent of dedication decreases, the level of risk of potential contamination increases. This entire spectrum of risk is represented in Figure 1. While it is beyond the scope of this chapter to suggest where on the spectrum each company should position its facility, it is important that each company use a risk assessment process and establish the reasonable degree of risk based on the nature of their specific products and thus determine where they fit on this spectrum. This will be a major aid in developing a strategy for the cleaning program.

## V. A POTENTIAL SIMPLIFICATION

In the previous section it was obvious that cleaning in large facilities with many different products and cleaning for products administered by different routes of administration can quickly become very complex. There is one factor that can work in our favor to simplify our cleaning program, however, and it is well to mention it up front and use it whenever feasible. The simplifying principle is to use disposable materials whenever possible. Examples are hoses, tubing, filling needles, and glassware. Obviously this will need to be evaluated on a case-by-case basis and subjected to cost analysis. For example, it may be feasible to



**Figure 1** Type of facility versus degree of risk of cross-contamination.



discard 10-ft sections of 1/2-in. plastic tubing costing only a few dollars, but it certainly is not economically feasible to dispose of a \$10,000 braided, stainless steel-reinforced, custom-made hose after each batch is manufactured. The main point is that classifying certain “difficult to clean items,” such as filters, hoses, gaskets, and glassware, as disposable can simplify your cleaning program.

## **VI. TYPES OF CLEANING SITUATIONS**

Another factor that helps define the cleaning strategy is recognizing the type of cleaning situation we are faced with relative to what is going to be manufactured next in the equipment. I like to tell people that you’ve got to learn to look downstream in cleaning validation in order to determine what you might contaminate and thus determine the element of risk. Some situations are simply more risky than others and we must be able to study and deal with risk. We must be able to accept a certain level of risk because it is always with us and unfortunately cannot be driven down to absolute zero.

A useful exercise is to list some typical changeover situations and examine the potential for contamination. These changeover situations might be quite different from one part of our industry to another. For example, in the manufacture of APIs there are the following types of changeovers:

### **A. Changeovers for API Facilities**

- Switch from batch to batch for same product (campaign situation)
- Switch from final step of one product to final step of different product
- Switch from final step of one product to intermediate step of a different product
- Switch from final step of one product to initial step of a different product
- Switch from intermediate step of one product to final step of another product
- Switch from intermediate step of one product to intermediate step of another product
- Switch from intermediate step of one product to initial step of another product
- Switch from initial step of one product to the intermediate step of another product
- Switch from initial step of one product to the final step of another product
- Switch from initial step of one product to the initial step of another product

We easily came up with a list of 10 different types of changeover situations for the manufacturers of APIs. Many companies do a risk analysis since the risk

associated with changeover is different for these types of changeover situations. For example, switching from an initial or intermediate step of one product to the final step of another may be more risky than switching from an initial step of one product to the initial step of another. The reason is that in the manufacture of APIs there may be additional purification in later steps that would remove any contaminant even if it did carry over. In the final steps we may be beyond the purification steps, and thus any contaminant that makes it that far in the overall process will likely appear in the finished API product.

In the manufacture of drug dosage forms, there are still other changeover situations. Some typical ones are as follows:

Changeover from one batch of a product to another batch of the same product

Changeover from one product to a different product

Changeover from one strength of a product to a different strength of the same product

Changeover from a product given by one route of administration (oral, topical, ophthalmic, etc.) to a product given by a different route of administration

Even for the manufacture of medical devices or diagnostic agents, there are still other equally challenging changeover situations. The point to be made here is that the changeover situations have different inherent risks associated with them and we need to study them, be aware of them, and build them into our master plan or strategy for cleaning.

## **VII. CLEANING NEW EQUIPMENT**

In some respects, new equipment arriving at a facility may represent a more significant risk of cross-contamination than older equipment that has been on site for some time. At least we have a historical knowledge of the products made in the older, on-site equipment and can focus on known expected residues. With new equipment, we may not have a clue, analytically speaking, of what to look for on the equipment. The equipment could be coated with protective lubricants, dyes used in testing the equipment, acids used in passivation, and a host of other chemical and microbial agents. In a very real sense, new equipment may represent a time of maximum danger of contamination. It is therefore important that cleaning and evaluation of cleaning be an important aspect of commissioning new equipment. It is a good idea to “partner” with the supplier on this issue in order to gain some early information on expected residues. A few years ago, a common regulatory expectation was that product-specific assays were always superior to nonspecific assays. In this case, because we may not

know what we're looking for analytically, the nonspecific assay may give us more information as to potential contaminants than the specific assay since we could overlook residues if the assay is too product-specific. This is especially important for "closed" systems, or systems that are so complex that they may not invite easy visual examination to all product contact surfaces.

## VIII. WHEN IS CLEANING VERIFICATION APPROPRIATE?

Cleaning verification is not a play on words, but rather a very useful philosophical approach that is appropriate for development activities, including dosage form development (R&D), and for activities associated with chemical or biological synthesis of the active moiety. During the development phase of a product, there is a need to be flexible enough to not hinder the development process. To adhere to classic three-batch validation requirements would significantly slow development and add to the already high cost of developing new pharmaceutical products. During chemical development, many new synthetic routes must be developed and optimized. Since the parameters are constantly being varied, it is unlikely that there could be two runs exactly the same. Indeed, it would be a waste of resources to do so since no useful development information would be gained from the second or third identical run.

Likewise, in the development of dosage forms, the research pharmacist must quickly try different formulations, batch sizes, and dosage strengths to supply the clinical trials so that the human dose and the efficacy can be determined. This required variation is the very antithesis of validation, and we should not try to state that validation occurs during development. At the very best, validation might only just begin during the development phase of a product. More than likely, once development is complete, process and cleaning validation will occur during the production of the first three commercial lots of product. The transition between development and commercial production has often been described as "drawing a line in the sand." Development is on one side of the line, and the understanding among regulatory agencies and industry is that such facilities may not be fully compliant with the full legal definition of current good manufacturing practices regulations (CGMPs). As soon as the product development is complete, however, then a line should be drawn in the sand and every activity beyond the line will be subject to full CGMP requirements, including validation.

It is appropriate to discuss cleaning verification in a little more detail since the principle of cleaning verification is currently very widely used in development facilities. The main difference between verification and validation is in the number of events captured. For validation, the requirements to refer to a cleaning process as "validated" are that, first of all, three identical batches of a single

material must be manufactured and the equipment cleaned after each manufacturing event, thus generating three sets of cleaning data. The batches must be identical (e.g., same formulation, same concentration of active, same batch size, same equipment). Likewise, the cleaning procedure and cleaning agent must be identical in all three cases. This is necessary to avoid meaningless comparisons of “apples and oranges.” The use of the multiple cleaning events is necessary to demonstrate that the cleaning process is consistent.

For cleaning verification, there is a unique single manufacturing event and a single cleaning; thus a single set of data is generated. There is a cleaning verification protocol, however, in which samples are taken and tested after the cleaning is complete, and results are compared to pre-established, scientifically justified limits. There is thus no risk of contamination to products subsequently manufactured in the equipment. This approach is certainly not validation and there is no claim that it is; however, there is no risk to the patients and this approach allows development to proceed without wasting time on redundant operations that serve no purpose during the development phase.

## **IX. VALIDATION OF THE CLEANING PROCESS**

Eventually the point will be reached at which the development of a product is complete; the formulation is finalized, the equipment has been selected, the analytical methods are validated, the development transfer report has been issued, and the Preapproval Inspection (PAI) is anticipated. Now is the time to consider validation of both the manufacturing and cleaning processes. Although some process validation may have also been completed or a process validation protocol may have been prepared and approved, it is likely that very little has been finished that would enable us to state that the cleaning process is fully validated.

At this time, if it has not already been done, it might be advisable to develop a cleaning validation master plan (CVMP). This may already exist as a stand-alone document or as a part of the overall validation master plan. The document is probably not product-specific, however, but rather of a more general nature. Even if the company already has an existing CVMP, many companies may choose to develop a more specific and detailed document, referred to as a cleaning validation *working* master plan. This latter document might include many more details and would help manage the “who, what, how, and when” questions for the specific new product. In summary, the CVMP would be more general and would deal with all the products within a given facility. On the other hand, the cleaning validation working master plan would be designed for a single product, and if implemented, would have as its primary purpose to guide, control, and guarantee that the company would develop cleaning valida-

tion documentation for the new product in a timely fashion. There are no regulatory guidelines on the exact approach a company must take regarding a CVMP. In fact, many companies have survived the PAI quite well without one. In other words, it is possible to have cleaning validation without having a CVMP. The authors' experience, however, has been that a master plan will serve as the "glue" that ensures that the process—either manufacturing or cleaning—will be validated in the most efficient manner. Without a CVMP, we essentially start over each time a new product comes along and we get very good at "reinventing the wheel." This may also be true whether we are speaking of a truly new chemical entity (NCE) or just a product that happens to be new to our operation. For example, the world of contract manufacturing and contract packaging is one in which the product profile is ever-changing; so let me summarize by saying that "If you don't know where you are going, you are probably not going to recognize it when you get there."

## **X. ELEMENTS OF A CLEANING VALIDATION MASTER PLAN**

To some extent, the elements found in a CVMP will depend upon whether the company already has an existing validation master plan or some formal policy document that addresses cleaning. As mentioned earlier, the author's experience has been that most of the global documents are "umbrella" documents that do not contain a lot of detail but simply make the commitment to meet standard regulatory requirements as expressed in the CGMP regulations. That is certainly acceptable, especially for a company that is small and has only one or two products or maybe for a new startup venture in which the first product has yet to reach the commercial market. It should be stated here that a company should not develop more documentation or "heavy-duty" master plans than are truly needed or appropriate for their particular company situation. So, for the record, let us emphasize that for these single-product or small ventures, a particular company would be well advised to proceed directly to a cleaning validation protocol that could encompass all the necessary details and not waste time developing a meaningless master plan.

Having covered the needs of a small company let's turn our attention to the needs of larger, multiple product companies or small companies that plan to grow rapidly. You may have heard the saying "We never seem to have time to do things right the first time, but we always seem to have time to repeat them." Assuming that we want to do it right the first time, here is a list of some items that might be appropriate for a CVMP. I am assuming that the company does not have an extensive plan integrated into a facility validation master plan. I am

further assuming that you realize that this is a menu or a list that the user can choose from and not a “must do all items” type of list.

## **XI. POTENTIAL ITEMS FOR A CLEANING VALIDATION MASTER PLAN**

1. *Purpose*—A statement of the objective of having the plan. The statement may be either concise or general in nature, depending on the situation. It should indicate that the overall objective is to create a plan that will provide the documentation that proves that the cleaning procedures are appropriate and consistent, and that will satisfy the expectations of the regulatory agencies and the current good manufacturing practices (CGMP) regulations.
2. *Strategy or approach*—This section should address the approach to be used. For example, if products are to be grouped according to similarity in dosage form, potency, and the like, and a “worst case” selected, this would be the appropriate section in which to mention this approach in either general or specific terms, depending on the company’s needs. To elaborate, the company may be a new startup venture in which the exact future use of the product may not be known (e.g., a new drug whose route of administration, dosage, etc. may not yet be established). In this case it might be well to indicate a flexible strategy, depending on the future development of the new product. In other cases, the company and its products may be very defined and mature. In this latter case it may be possible to indicate a very defined and refined strategy in the CVMP.
3. *Cleaning in development areas*—As mentioned earlier, cleaning verification might be more appropriate than cleaning validation in development areas. This includes chemical, biological, and biochemical, as well as pharmaceutical development activities. These activities usually occur with early analytical methods; that is, prior to having validated analytical methods. It must be remembered that analytical methods development is usually on a parallel path to the development of the final product. It is appropriate to use the “best available” analytical method to verify the cleaning of equipment, thus the cleaning of equipment in development areas must proceed in a slightly modified fashion. In the early stages, it may be quite adequate to clean equipment with, for example, an organic solvent. Now this would be clearly impossible at a later stage of development or in dosage-form manufacturing equipment. Equipment may often be pronounced clean by a combination of visual examination of the

equipment and a fairly simple chemical analysis; for example, spectrophotometric or total organic carbon (TOC) methods.

4. *Selection of products for cleaning validation*—In some cases in which a company is faced with validating the cleaning for many different products that are quite similar in their manufacturing equipment and the manner in which the product is administered. In a “blanket” approach, the company must establish the reliability of its cleaning processes for every combination of product and equipment. The numbers of combinations and permutations are staggering and would result in literally thousands of samples. Many companies, therefore, choose to identify a worst-case product that would serve as the model to satisfy the need to demonstrate that cleaning processes are adequate. For example, consider a series of drugs, all of which are administered to the patient in the form of a tablet. They differ, however, in potency. (Some are more potent and others are less potent.) They also differ in their basic physical properties, such as solubility. Presumably those materials that are least soluble will be more difficult to clean. Consider the simple example in Table 1.

Let’s examine this simple example by comparing the properties of the three drugs that are significant for cleaning purposes. Drug A is the most potent of the group by virtue of having the lowest dose required to give a medical effect. Drug A is also the least soluble of the three drugs, thus in the example in Table 1, drug A is clearly the most important for cleaning purposes and represents the worst-case product. Now admittedly this is a very simple example, and life is not always this simple in the world of cleaning. Indeed, we often do not have a clear case of the worst case, but rather, a situation with trade-offs. To see what I mean, let’s examine [Table 2](#).

Examination of the data in Table 2 indicates a more complicated situation. Drug D is the most potent of the group (i.e., it has the lowest medical dosage). Drug I is the least soluble, however. We

**Table 1** Table of Potency and Solubility

Drug	Medical dosage (potency)	Solubility in water
Drug A	1 mg	10 mg/liter
Drug B	10 mg	20 mg/liter
Drug C	100 mg	30 mg/liter

**Table 2** Table of Potency and Solubility (Example 2)

Drug	Medical dosage (potency)	Solubility in water
Drug D	10 mg	20 mg/liter
Drug E	15 mg	100 mg/liter
Drug F	20 mg	150 mg/liter
Drug G	100 mg	200 mg/liter
Drug H	200 mg	500 mg/liter
Drug I	500 mg	1 mg/liter

could compare the two products by simply stating that drug D is 50 times more potent than drug I but 20 times as soluble. We could thus make a pretty good case to consider drug D as the worst case of the group. It would be much wiser, however, to consider both drug products as the worst cases and do cleaning validation on both products D and I. A couple of points are demonstrated by this example. First, when there isn't a clear worst-case product in the group it is advisable to choose more than one product for the worst cases. Second, it is important that the formulations of all products in the group be very similar. One of the biggest myths in pharmaceuticals is that the excipients are inert and have no effect upon the performance of the product. All pharmaceutical scientists realize this is not the case and never was. For example, if any of the products in the group were in a sustained release formulation containing, for example, a wax or polymer, then the same excipient that prolongs the medical effect would also delay the dissolution and thus present a greater cleaning challenge than the other instant release formulations. The main principle here is that it is necessary to compare truly similar formulations and not compare apples to oranges.

5. *Analytical methods validation*—As mentioned earlier, a good CVMP should allow the analytical method to develop concurrently with the product formulation, thus in the early stages of development, an analytical method may not be fully validated but may still be used for cleaning tests as the best available method. At the time of the PAI, however, and definitely by the time the formal cleaning validation occurs, a fully validated analytical method should be developed. This methods validation package should include all the standard parameters, with special attention to the sensitivity of the analytical method as expressed by the limit of detection (LOD) and



the limit of quantitation (LOQ). It is critical that the analytical method be sensitive enough to detect residues in the concentration range calculated as an acceptable limit for the residues.

6. *Approach(es) to setting limits*—The approach to setting limits will be determined by the nature of the residue(s) and may differ for different situations within the same company. For example, the approach will differ for the calculation of residues associated with the manufacture of APIs and their related intermediates and precursors. Of necessity, it will also differ for the approach to be used for limits for residues associated with the production of such dosage forms (e.g., actives, detergents, and bioburden). It is not necessary to elaborate on the approach to setting limits in the CVMP. In fact, it is usually a mistake to do so. It is sufficient to indicate in the CVMP that limits will be established and justified for all potential contaminants and that this information will be included in the scientific rationale section of the individual protocols.
7. *General approach to sampling*—Although there are potentially many different types of sampling, the main objective in a CVMP should be to briefly mention all the types that may be used not only for current products but also for future ones. Thus, even if a company feels that it would like to do swab testing of equipment, it would be preferable to allow the sampling methodology to be determined and justified by the specific product protocol. It is also preferable to mention that the method of sampling will be appropriate to the equipment and products to be evaluated as well as to the nature of the test to be performed. This approach allows both swab and rinse sampling for product residues. It also provides for specialized sampling, such as by Rodac plate for bioburden and coupon sampling for detergent. Probably the most common error made with regard to sampling methodology is to specify a single sampling method and then determine later that it is not appropriate for a given situation.
8. *Assignment of responsibilities*—The actual approach in this section may be general or specific, according to the preference of the company. Many companies, especially the larger ones, find it convenient to specify the individuals responsible for the many activities associated with cleaning validation. For example, one “set” of individuals may be responsible for the creation of the master plans, protocols, and final reports. Still another group may be responsible for the review of the documents, and yet another group may be responsible for the final approval. There is also the possibility of deviations during the execution of the protocol and failures of the final results to

meet the acceptance criteria. One must conclude that there will be a large number of documents to be prepared, written, and approved. It is thus helpful to have some sort of chart or other organizational tool to help manage this situation. A typical chart is shown in Table 3.

9. *Schedule of activities*—Scheduling the various activities associated with validation can be very simple or very complicated, depending on the size and complexity of the company, the number of sites involved, the nature of the equipment, and the number of products involved. For simple situations, such as a small company manufacturing a single product in a simple manufacturing process, the schedule of activities could be a written list or kept on a computer spreadsheet. For a more complicated situation involving multiple facilities, sites, and products, it may be necessary to use such standard planning tools as Gantt charts.
10. *Review and approval process*—The plan should address the review and approval process for all protocols and other documentation created as a result of the validation process. This would also include deviations occurring during the implementation of the validation protocols and any failures of data to meet acceptance criteria.
11. *Qualification of equipment*—The manufacturing equipment and the specialized equipment required for cleaning, such as tanks, heat exchangers, and sprayballs, must themselves be qualified prior to validation of the cleaning process. This means that installation qualification (IQ) and operational qualification (OQ) testing must precede the validation of the cleaning process. A company that completes cleaning validation prior to equipment qualification runs the risk of having to repeat the cleaning validation due to equipment not being installed correctly or not performing according to the supplier's

**Table 3** Chart of Responsibilities

Activity	Preparation	Review	Approval
Cleaning validation	V	QA, P	QA/P/E
Cleaning protocols	V	QA, P, E	QA/P/E
CV report	V	QA/P/E	QA/P/E
Deviation reports	V	QA/P/E	QA
Failure reports	V	QA/P/E	QA
Corrective actions	V	QA/P/E	QA/P/E

*Note:* V = validation department; QA = quality assurance department; P = production department or unit; E = engineering department.

specifications. A related factor is that there must exist a preventive maintenance and calibration.

12. *Validation of computer systems controlling automated cleaning processes*—Certain types of cleaning, namely clean in place (CIP) and clean out of place (COP), are associated with automated or semiautomated control of the cleaning process by a dedicated computer referred to as a programmed logic controller (PLC). This type of automation requires that the PLC be validated and/or controlled prior to the start of the validation of the cleaning process itself. The approach to the validation of computer systems involved in cleaning should be addressed in the CVMP.
13. *Training of personnel (manufacturing and laboratory)*—In order for the procedures associated with cleaning to be demonstrated as being consistent, it is necessary to have them carried out in a consistent fashion. This means that operators who do the actual cleaning must be formally trained on detailed, finalized cleaning procedures regardless of whether the cleaning is manual or automated. Training applies not only to production operators, but also to laboratory personnel who sample cleaned equipment and assay the resulting samples. It is important that the training of both manufacturing and laboratory personnel be documented and carried out on the current version of the cleaning procedure. The CVMP should address training in a company-specific manner and should be general in nature. It should require that the validation personnel obtain some type of written declaration or certification that training is current at the time of the actual validation of the cleaning processes. Although training may appear to be an obvious requirement for validation, it is amazing that it continues to be a major source of problems either directly or indirectly.
14. *Documentation requirements*—Several activities associated with validation of the cleaning processes may generate documentation, which may be addressed in the CVMP. They are
  - a. Cleaning verification protocols
  - b. Installation qualification of auxiliary cleaning equipment
  - c. Operational qualification of auxiliary cleaning equipment
  - d. Deviation reports and associated investigation reports for deviations occurring during the cleaning validation study (e.g., deviations occurring during the cleaning procedures, collection of samples, or related activities)
  - e. Cleaning validation protocols
  - f. Cleaning validation reports
  - g. Out-of-specification (OOS) investigations associated with failures during the cleaning validation studies

15. *Use of consultants (if appropriate) and assessment of their credentials*—With all the outsourcing of activities and expertise occurring in pharmaceutical and other industries, it is not unreasonable to evaluate and document the qualifications of consultants who are involved in many activities in the pharmaceutical facility that can and will have CGMP impact on facilities, processes, and procedures. This would include but not be limited to some of the following examples:
  - a. Construction of facilities and systems such as purified water and heating, ventilation, and air conditioning (HVAC)
  - b. Installation of manufacturing and packaging equipment
  - c. Installation of CIP cleaning systems
  - d. Installation of washing machines (COP)
  - e. Contract analytical testing facilities
  - f. Validation consultants

It would be reasonable to keep a file of documentation demonstrating the expertise of these services and any outside consultant performing operations having the potential to impact GMP operations. It is quite surprising to note that many companies do an excellent job of keeping detailed training records for their own permanent employees but have only the name of the firm of the outside consultants performing such critical services as cleaning on behalf of the parent company.

## **XII. PRIOR PREPARATION FOR VALIDATION OF CLEANING PROCEDURES**

As mentioned previously, there are many activities that should be completed before cleaning validation can be initiated. Some examples are

*Verifying that manufacturing equipment and product formulation are finalized (e.g., as specified in a development transfer report)*—This is necessary since cleaning methods are product- and formulation-specific and will change if the formulation or equipment is changed.

*Evaluation of cleaning procedures themselves*—Many companies prefer to perform a prevalidation study (often referred to as a “process capability study” or “engineering run”) to verify that the cleaning procedure is satisfactory prior to the actual validation runs. This is an excellent opportunity to determine if the cleaning procedures are adequately written. On some occasions, cleaning procedures are not detailed enough and may not provide enough information about, for example, the extent of disassembly of the equipment. If left to interpretation, there is the possibility that different operators may interpret the instructions differ-

ently, and this represents a potential source of variation that could undermine the entire cleaning program. The review should also verify that not more than one cleaning agent has been specified for a particular combination of equipment and product. (The reason I say “not more than one” is that some companies do not use a cleaning agent for the cleaning.)

*Validation of analytical methods*—The analytical or test methods to be used for the cleaning validation must be completed and validated prior to the cleaning validation. Not doing so would risk the need to repeat the entire cleaning validation after the analytical method is validated. Although a complete, detailed discussion of methods validation is clearly beyond the scope of this chapter (see reference), there are several essential points that should be noted with regard to the analytical method and its validation. First, the analytical method must be validated before it can be used to test the official cleaning validation samples. Second, the most important validation parameter for cleaning validation is the sensitivity of the analytical method. The analytical method must be sensitive enough to detect residues at levels below the acceptable carryover limit (i.e., limit). The sensitivity of the analytical method is a known parameter, usually described as the LOD or LOQ. Another analytical issue is whether the analytic method is specific or nonspecific in nature. This latter terminology refers to whether the method will detect a specific product or whether it will generally react with and detect a group of products or residues. It is generally concluded that the evaluation of residues of active ingredients must include product-specific assays. This does not mean that nonspecific testing is not extremely useful, however. There are instances in which nonspecific testing is not only useful but also possibly even preferable to specific testing. For example, when there are complex mixtures of residues possible, with several components having medical or possible toxic side effects, a nonspecific assay such as TOC may be useful in that it would pick up any or all of the potential component residues. Nonspecific testing is also useful for monitoring purposes and for process capability studies to determine if the cleaning process is effective. Combinations of several nonspecific assays, such as pH, conductivity, and TOC, often can be used to screen for any possible chemical type of residue. The point to be made is that the CVMP may mention that nonspecific types of assays may be used in addition to specific assays in cases in which it is appropriate to do so.

*Installation qualification, operational qualification, and preventive maintenance of instruments*—Since laboratory instruments will be used to determine the actual data that will prove the acceptability of the clean-

ing procedures, these instruments must be qualified (IQ, OQ) and included in a preventive maintenance (PM) program, which ensures that they stay in a controlled, calibrated state. Many suppliers of instruments now provide documentation templates, which help the user qualify the instruments. Installation qualification (IQ) and operational qualification (OQ) seem to be well controlled, but we must remember to be continuously alert to possible sources of problems with these critical instruments. Certain critical instruments such as balances and scales may be calibrated by outside contractors or services. It is important to recognize that these outside services may have a great impact on inside operations. Outside services must demonstrate a training program for technicians to ensure that critical equipment is calibrated consistently at each calibration event. The outside calibration service should also provide a detailed calibration procedure that describes exactly the details of the calibration procedure. It is not sufficient to have simply a “certificate of calibration”; this would not be acceptable for departments inside the company and no less should be expected from external services. Another potential source of problems for laboratory instruments is changes to software incorporated in the control module for the instrument. This software should not be changed without adequate change control evaluation, just as would be required for changes to manufacturing processes and equipment.

### **XIII. VALIDATION OF THE CLEANING PROCESS**

Once the prerequisites are in place, it is time to set about validating the cleaning process. The primary documentation associated with this event is the validation protocol.

### **XIV. ELEMENTS OF THE VALIDATION PROTOCOL**

*Scope*—This section describes the equipment, facilities, processes, and products covered by the protocol.

*Objective*—This section should describe exactly what the experiments are trying to achieve. A typical objective is “to demonstrate that the cleaning process is consistent and effective in removing residues of products, cleaning agents, and bacteria.”

*Sampling plan*—This section should address what type of sample (e.g., swab, rinse) will be obtained and the location of the sampling. Typically, diagrams or photographs are used and the areas to be sampled are marked or indicated on the graphic. It is important to indicate that

the most difficult to clean locations, often referred to as worst-case locations, will be included in the sampling locations. This is an expectation of the various regulatory agencies around the world. Currently the most common sampling methods are swabbing and rinsing. Other sampling methods may be used when scientifically justified. There is a myth that only swab sampling is acceptable, and this is simply untrue. In certain cases the configuration and nature of the surfaces to be sampled do not permit swab sampling. For example, for transfer pipes, hoses, and biomembranes, swab sampling should not even be attempted. Regulatory guidelines [3,4] mention both swab sampling and rinse sampling as acceptable methods of sampling for cleaning validation purposes. When using swab sampling it is important to obtain truly representative samples of all sections of the manufacturing equipment. This section should also specify the manner in which samples will be taken and stored prior to analysis.

*Analytical methodology*—This section should refer to the specific analytical method(s) to be used for the specific products, cleaning agents, and equipment for the protocol being evaluated. Many companies choose to have the detailed analytical methodology described in a separate report and reference only the report number in the actual protocol. There are certain parameters that should be included in the actual protocol, however. For example, the sensitivity of the analytical method, expressed either as the LOD or LOQ, should be included in the protocol since it will be necessary that the sensitivity of the analytical method be below the acceptance criteria for the residues so that a result of “none detected” can be interpreted. It must be remembered that “none detected” does not mean that there was no residue present, but only that the level of residue was below the limit of detection of the analytical method.

A second analytical parameter that is extremely critical for cleaning evaluation is the recovery factor for the specific analytical method. This is usually determined by spiking known amounts of the expected residue on surfaces of the same material (e.g., stainless steel, glass, plastics) as the equipment to be sampled. The recovery is defined as

$$\text{Percentage recovery} = \frac{(\text{amount detected}) \times 100}{(\text{amount spiked onto surface})}$$

The question often arises as to what an acceptable percentage of recovery is. There is no regulatory requirement for recovery, and indeed, the range of values reported varies greatly. Values as low as 15–20% have been reported by biotechnology companies. This is neither good nor bad, but instead a function of the nature of the materials, levels of

residue encountered, and may be the maximum attainable for such residues as poorly soluble materials such as proteins. For very soluble materials, the percentage recovery may be as high as 99.9%. Most typical recoveries fall somewhere in between these extremes, and typically would be in the range of 50–70%.

*Acceptance criteria*—This section of the protocol should present the requirements that must be achieved by the testing in order for the cleaning process to be considered acceptable. Normally there are several requirements that must be met. First, the equipment must be visually clean, which means that the product contact surfaces must be visually examined under adequate lighting. This sounds simple enough, but with today's complex equipment and closed systems, this may be much more difficult than it appears. In some cases, people have entered large equipment in order to be able to directly examine and sample surfaces that can not be seen directly (e.g., behind mixer blades, scraper blades, dip tubes, sprayballs, and inlet pipes). This entry represents an invasive technique, which some feel can potentially lead to additional quality issues. In some cases, the residues may be fluorescent in nature, and use of an ultraviolet (“black”) light will enhance the ability to detect the residue. This, in effect, increases the sensitivity of the visual examination process. The power of visual examination should not be minimized. Various scientists have found that for typical pharmaceutical products, the human eye is capable of detecting levels of 100 µg per 4 sq. in. or 25 µg/sq. in. [5]

The acceptance criteria may also specify the amount of active ingredient that may be present in the swab and/or rinse samples taken. This section of the protocol should also provide a scientific rationale or justification for the limits for active(s) remaining on the equipment. This particular topic is so significant that it is addressed in greater detail in Sec. XV.

The acceptance criteria may also specify limits on microbial counts, endotoxin, particulate matter, and other parameters appropriate or significant for the particular product. The author remembers one protocol that specified the absence of a characteristic odor that was indicative of a certain residue and was a sensitive yet simple measure of whether or not the equipment was adequately cleaned.

*Documentation*—This section of the protocol specifies what documentation must be included in the final validation report. Some potential documents are

The data collection forms used by the samplers

The analytical results data form prepared by the QC laboratory



- A training certification prepared by production supervisors attesting to the training of the operators who carried out the cleaning
- A training certification prepared by the QC laboratory supervisor attesting to the training of the samplers and lab analysts who sampled the equipment and analyzed the samples
- A report containing the analysis of the data obtained and an indication of whether or not the acceptance criteria were met
- A process deviation form describing any deviation from the original protocol and indicating the reasons for the deviation
- A failure investigation or OOS investigation report indicating the results of the OOS investigation, the identification of potential causes, any resampling or retesting data, and the corrective actions, if appropriate

*Training*—This section of the protocol should address the controlling mechanisms that will assure that personnel have been trained to carry out the cleaning process using a written, approved procedure, that samplers have been appropriately trained to take samples, and that laboratory analysts have been trained and are qualified in the analytical procedures to be used to evaluate or test the samples. The methods of documenting training vary from one company to another. Some companies actually name and identify the cleaning procedure and provide a document stating that specifically named individuals have been trained on the specific cleaning procedure. The statement is signed by the production supervisor. Other companies simply refer to the various departments' independent training files. The importance of the training and the documentation of the training cannot be overemphasized.

## **XV. DETERMINATION OF ACCEPTABLE LIMITS FOR THE CLEANING PROCESS**

Determining what is an acceptable amount of residue remaining on the equipment is at the very heart of cleaning verification and validation. The determination of acceptable carryover limits for pharmaceutical equipment and facilities is actually addressing the question of "What is clean?" To those who feel that equipment and facilities should always be cleaned to the level of analytical detectability, I will only say that approach is certainly always acceptable, and in some cases, a very reasonable approach. In most cases, however, cleaning to the lowest level of analytical detectability has a couple of major disadvantages. The first problem with this approach is that current analytical capability is so incredibly sensitive that the previously manufactured product(s) can almost al-

ways still be detected even after extensive cleaning. As a consequence, most cleaning procedures would need to be much more robust and detailed than those in current use. It is already quite common in the pharmaceutical industry for the cleaning process to require much more time than the actual production time to manufacture product, thus the inadequacy of current cleaning procedures is the first disadvantage. The second major disadvantage of this approach is that analytical technology, and thus the sensitivity of methods, is constantly changing and improving. Translating this factor into impact on the cleaning program would mean that if the limit was set as the level of analytical detectability, cleaning validation would need to be repeated every time a new, more sensitive analytical method becomes available. This is not practical or even feasible for most pharmaceutical operations.

To those who still aspire to zero level of cross-contamination, I would only add that we have different categories of cleanrooms (e.g., class 100, class 1000, class 100,000). We do not have a class that signifies no contamination; even our most stringent classification of pharmaceuticals, sterile products, is not absolutely pure. The regulatory requirement is that the probability of a nonsterile unit (PNSU) must not exceed 1 in  $10^6$  (i.e., 1 in a million). This is due to the fact that it is not possible to have 100% confidence that not a single unit will be nonsterile. It is simply not feasible, considering the nature of the physical facilities, manufacturing conditions, and imperfections in the testing process. While there is nothing wrong with our desire to produce the finest, highest quality products humanly possible, it will not be possible to achieve zero carry-over and still have the products be affordable to the patient.

The actual calculation or determination of limits will depend upon each individual manufacturing situation and thus must be customized for a given company or cleaning situation. Even companies with multiple manufacturing facilities may need to consider different approaches to setting limits for each individual manufacturing site, thus the setting of limits must be customized. There are many factors that should be considered in setting limits. The following list indicates some of the factors, but is not necessarily all-inclusive. In reviewing this list, please note that some of the factors relate to other products manufactured in the same equipment or the same facility. In other words, you must consider not only the potentially contaminating product, but also the other products that may be subsequently manufactured in the same equipment or facility.

## **XVI. FACTORS TO CONSIDER IN SETTING LIMITS**

- The nature of the primary contaminating product
- The medical dosage of the primary contaminating product
- The toxicity of the primary contaminating product

The solubility of the primary contaminating product in the cleaning media  
The inherent difficulty of cleaning the equipment (difficult-to-reach locations)

The nature of the cleaning process (i.e., automated versus manual)

How the product will be used by the patient or the customer

The nature of other products made in the same equipment (i.e., the potentially contaminated products)

The medical dosage of the contaminated product

The batch size of other products made in the same equipment

In order to understand how each of these factors can be important in setting limits, let's consider each factor briefly.

*The nature of the primary contaminating product*—The nature of the primary potentially contaminating product refers to how the product is administered to the patient. Is the product a finished pharmaceutical dosage form or is it a precursor or chemical intermediate that will be used as a starting material by other companies to manufacture finished products? Are the products sterile or nonsterile? What is the route of administration of the product (e.g., oral, topical, intravenous, ophthalmic)? The answers to these questions will dictate the actual calculations to be used to determine acceptable limits.

*The medical dosage of the primary contaminating product*—The medical dosage or potency of the potential contaminating products will be an important consideration. For some residues (e.g., active ingredients in finished pharmaceutical products) this will be a known number. For other potential residues (e.g., precursors, chemical intermediates, and cleaning agents) this will not be known since these materials are not used medically and therefore have no established medical dosage. As a side note, it should be pointed out that obviously many chemical substances have no known medical dosage but can cause harmful medical effects to the body. We must therefore establish acceptable limits for these materials. In order to be more conservative, some companies use the smallest medical dose or the pediatric dose for calculation purposes for those materials that have known medical doses.

It should also be noted that the limits calculated (to be discussed in a later section) are directly related to the medical potency of the contaminating product. For example, the higher the medical dosage the greater the absolute amount (total weight) of material that could safely be allowed to carry over to another product if all the other variables were equivalent.

*The toxicity of the primary contaminating product*—In the cases mentioned earlier, in which no known medical dosage exists (e.g., precursor

sors, intermediates, cleaning agents), we must resort to some other parameter for calculating acceptable limits. The most common method is to base the calculation on the toxicity of the potential contaminant. The absolute limit is some fraction of the toxic dose with a considerable safety margin built into the equations. It is thus often essential to know certain animal toxicity parameters, such as the lowest lethal dose or the lethal dose for 50% of the animal population ( $LD_{50}$ ). The actual calculations using this method are demonstrated in a later section of this chapter.

*The solubility of the primary contaminating product in the cleaning media*—The actual solubility of the potential contaminant (i.e., the product to be cleaned) is often very useful in predicting the most difficult to clean product. It is very simple to predict that the more water-soluble the contaminant, the more easily or quickly it can be cleaned and the less amount of water or contact time with the rinse water will be needed to effectively clean the residue. In some cases, materials that are poorly soluble in water must be cleaned with other solvents, such as alcohol or acetone. In biotechnology facilities, it may be necessary to clean with both acidic solutions and basic solutions since multiple types of protein residues may be present, some of which are more soluble in acidic solutions and others more soluble in basic solutions. Cleaning in facilities that manufacture API, often requires the use of organic solvents (alcohol, acetone, etc.) because of the insoluble nature of the chemical residues. Aqueous cleaning with added cleaning agents such as surfactants, soaps, or detergents is also common, and often the cleaning agents are specifically selected based on the science of what materials are most effective in removing the anticipated residues. Today's cleaning agents are complex mixtures of surfactants, antifoaming agents, chelating agents, builders, enhancers, alkali, acids, soaking agents, and several other materials. The actual mechanism of removal of residues may involve dissolution, mechanical removal, emulsion formation, chemical reaction, and other physical and chemical interactions and is beyond the scope of this presentation. The suppliers of cleaning agents to the scientific community, however, are willing and able to supply recommendations and information that is valuable in the cleaning process and the validation of the cleaning process.

*The inherent difficulty of cleaning the equipment*—Regardless of the solubility of the potentially contaminating residues, there are other factors that may contribute to the difficulty of cleaning equipment. The geometry and physical configuration of the equipment may sometimes lead to situations in which it is difficult to clean equipment. For example, the equipment may be intricate (e.g., microfluidizer, biomembranes). The

equipment may also be very difficult to disassemble and difficult to view physically (i.e., closed system). Modern equipment is typically equipped with many internal components, such as mixers, probes, dip tubes, valves, and pipes, that contribute to the difficulty of cleaning. In some cases, the excipients in a pharmaceutical formulation may contribute to cleaning difficulties. For example, even water-soluble actives are difficult to clean if present in an ointment or cream. In these cases, product residue must often be removed physically by scraping to speed up the cleaning process.

*The nature of the cleaning process (i.e., automated versus manual)*—The type of cleaning process (i.e., manual, semiautomated, or automated) is usually determined by the nature of the equipment. For example, large closed systems often are cleaned by automated CIP techniques. For other equipment that is relatively small and easily disassembled, it is more practical to disassemble the equipment and place it in centralized washing machines. For still other equipment (e.g., packaging equipment), manual cleaning is more appropriate. Although it is true that automated procedures tend to be more consistent than manual procedures, the author has observed several situations in which good manual cleaning is superior to poor automated cleaning. Automated cleaning procedures will require greater resources to validate initially (software validation), but will probably provide greater consistency than manual cleaning procedures over the long term. The limits selected for manual cleaning may need to allow for a greater variation in the results due to the human factor. Without a doubt, however, manual cleaning requires detailed cleaning procedures and serious attention to training.

*How the product will be used by the patient or the customer*—Here again our industry is so diverse that we must indicate that the limits calculated should take into account the nature of the customer. Is the customer another company that uses the product, which may be a chemical, to make another intermediate, or is the customer the patient who actually takes the product in the form of a finished pharmaceutical dosage form? Is the product a sterile product and do we need to consider bacteria as a potential contaminant or is the product a nonsterile product in which bacterial contamination may be a lesser issue? If the product is a finished pharmaceutical dosage form, will it be used intravenously, orally, ophthalmically, topically, rectally, vaginally, or by other means?

*The nature of other products made in the same equipment*—It is also necessary to consider the products that are going to be contaminated; that is, those that are “downstream” in the manufacturing sequence. How many are there and how diverse are they? Imagine the situation that occurs if the first product in a manufacturing sequence is adminis-

tered topically but the next product to be manufactured in the same equipment could be given orally. This difference in the route of administration can lead to different approaches in the determination of limits.

Another situation occurs in an API facility when actives are often made without the knowledge of what the ultimate route of administration to the patient might be. For example, it might be that an active made first in the equipment would be intended for oral administration only, but the next scheduled synthesis is for the active for a product to be administered intravenously. The amount of material that can give a medical or toxic effect intravenously may be much less than that given orally, and the limits would need to be appropriately modified. This information should be factored into the limits calculation.

The author is again trying to convey how important it may be to consider the next product or other products made in the same equipment.

*The medical dosage of the contaminated product*—The typical (some companies use maximum) daily dosage of a potentially contaminated product should be considered in the determination of limits. The idea here is simply that whatever the level of cross-contamination, the more of the contaminated product the patient consumes the greater the amount of contamination taken by the patient. Consider a tableted product. If the daily dose of the tablet is 24 tablets per day, the patient will receive 24 times as much contaminant than if the daily dose of the product was one tablet per day.

Another example would be for the case of products administered by injection. Compare the difference in the total amount of contaminant a patient would absorb for an injectable given as a single 2-cc injection daily in contrast to the amount received if the contaminated product is a large-volume parenteral (e.g., dextrose solution) that could be administered in amounts as large as 12 L (12,000 cc) per day.

Again the point to be made is that it is important to know what the next product (i.e., the potentially contaminated product) is and how it will be administered to the patient.

In cases in which we don't always know what the next product is going to be, the standard approach is to calculate limits based on the worst-case next product. The worst-case product will simply be the product made in the same equipment, administered by the same route of administration, and having the highest daily amount administered to the patient.

*The batch size of other products made in the same equipment*—Another factor that should be considered in determining limits for cross-contamination of products is the batch size of other products made in the same

equipment. This is a simple concept that basically states that if a given amount of contaminant is carried over to the next product, the contaminant will be more concentrated in the next product having the smallest batch size (where subsequent potential products may have different batch sizes). A corollary would be to state that the larger the batch size of the subsequent product, the more the contaminant would be “diluted.” This is an important distinction in trying to select the worst-case batch size of subsequently manufactured products to choose in calculating the absolute amounts of allowable carryover. Consider the data in Table 4.

For this simplified set of data, Table 4 indicates that for the batch sizes of the five products product B should be chosen as the worst-case batch size and this value should be used for calculation of the allowable carryover limit. This is because product B is the product of smallest batch size.

## **XVII. NUMERICAL CALCULATION OF LIMITS**

Before beginning the actual calculation of limits, it is necessary to consider the nature of the residues. There are basically four types of potential contaminants that lend themselves to establishing formal quantitative limits based on numerical calculations, namely

- Residues of active ingredients
- Residues of chemical precursors and intermediates
- Residues of cleaning agents
- Microbial residues and endotoxin

Each company must establish the limits for its products and processes based on its knowledge and expertise regarding the products and their associated manufacturing and packaging processes.

**Table 4** Table of Batch Sizes of Subsequently Manufactured Products

Product	Batch size
B	10 kg
C	15 kg
D	100 kg
E	120 kg
F	150 kg

## A. Risk Assessment

Before beginning the actual calculation process, it may be desirable to consider the risk associated with possible cross-contamination. For the chemical residues (i.e., excluding microbial and endotoxin residues) it is feasible to ask the question, "What level of cross-contamination could cause a medical or toxic effect in another product?" Again the answer to this question is often "It depends on how the product is administered to the patient." Several authors [5,6] have referred to the use of "safety factors" for the purpose of dealing with the risk associated with potential cross-contamination. The safety factor could also be considered to be a risk assessment factor. Many companies have chosen to use a standard safety factor of 1/1000 for all limits calculations. This means that any product when administered at 1/1000 of its daily (or some companies use lowest) therapeutic dose will not cause a medical or a toxic effect to the patient if administered by the same route of administration. It is important to note that this assumption is not true if the cross-contamination could carry over into a more effectively absorbed dosage form. For example, it should not be applied to cases in which the cross-contaminant could carry over from a topical dosage form to an oral dosage form or from an oral dosage form to a parenteral dosage form.

Another approach to safety factor determination is to use different safety factors based on the risk associated with the potential cross-contamination. This would mean that in certain cases 1/1000 might be insufficient to guarantee the safety of the patient, while in other cases it might be overly safe. For example, if the equipment was used to manufacture highly toxic or allergenic materials, certainly a safety factor of 1/1000 might be inadequate. On the other hand, if the company manufactures only topical ointments applied to nonabraded skin, then a safety factor of 1/1000 might be too conservative and would add to the cost of the products without adding any significant benefits. For this approach, a scale of variable safety factors might be used, as illustrated in Table 5. Using this approach ensures that the risk of potential cross-contamination for different dosage forms is evaluated before the actual limits are calculated.

**Table 5** Safety Factor Continuum

Dosage form	Safety factor
Research compounds, allergenics, toxics	1/100,000 to 1/10,000
Intravenous products	1/10,000 to 1/5,000
Ophthalmic products	1/5,000 to 1/1,000
Oral dosage forms (tablets, capsules, caplets)	1/1,000 to 1/5,000
Topical products (ointments, creams)	1/100 to 1/1,000



Again it should be emphasized that the above safety factors apply when the products are of the same dosage form. Switching from one dosage form to a different route of administration invalidates this approach, so the rule is “Be cautious.”

## **XVIII. CALCULATION OF TOTAL CARRYOVER LIMITS BASED ON THERAPEUTIC OR MEDICAL DOSAGE**

As an example of a simple limit calculation, assume product A is manufactured and the equipment is subsequently cleaned before manufacturing other products. Assuming that product A will ultimately be used as an oral tablet and that the smallest therapeutic dose is 100 mg, a safety factor of 1/1000 is applied. This means that the next product could safely contain not more than

$$100 \text{ mg} \times 1/1000 = 0.1 \text{ mg of the active ingredient in product A per daily dose of next product B}$$

If it is known, for example, that the following product, product B, will have a maximum daily dose of 500 mg (e.g., 10 tablets, each containing 50 mg of active) and a batch size of 300 kg of active ingredient, then it is possible to calculate a total carryover limit as follows. Converting the 300-kg batch to mg yields

$$300 \text{ kg} = 300,000,000 \text{ mg (total amount of active in product B)}$$

The number of daily doses in the entire batch of product B would be

$$\frac{300,000,000}{500} = 600,000 \text{ daily doses}$$

Since 10 individual doses are taken per day by the patient, this represents 600,000 daily doses.

If each daily dose is safely allowed to have 0.1 mg of previous product (A), then the total allowable carryover of product A into product B would be

$$600,000 \times 0.1 \text{ or } 60,000 \text{ mg or } 60 \text{ g A}$$

It is important to note that the 60-g limit appears to be quite large; however, this is the total residue allowed for all manufacturing and packaging equipment. For more potent products, the total allowable carryover would be greatly reduced.

It should be noted that this is only one simple example of a method to calculate a limit based on smallest therapeutic dose.

Some companies use a worst-case approach for this calculation. In the above example, the calculation would be modified by using the smallest batch size of any product made in the same equipment and the largest daily dose of

any product made in the same equipment. This allows a single limit to be set instead of having different limits depending on the parameters of the following product. For the above example, if the smallest batch size for any other product made in the equipment is 100 kg of active ingredient and the largest daily dosage of any other product made in the same equipment is 1500 mg of active ingredient, then the limit calculation would be

$$\begin{aligned} 100 \text{ kg} &= 100,000,000 \text{ mg} \\ \frac{0.1 \text{ mg}}{1500 \text{ mg}} &= \frac{x \text{ mg}}{100,000,000 \text{ mg}} \\ x &= 6,667 \text{ mg} \end{aligned}$$

In this case the limit is calculated to be 6.667 g.

It is important to understand that it is not a case in which one of the above methods of calculation is correct and the other incorrect. By the first method, a different calculation would be required for each and every product that followed product A. There would thus be a different limit if product B followed product A, if product C followed A, if product D followed product A, if product A followed B, and so forth, for every possible combination and sequence of manufacturing events. This would become very unwieldy to manage, and thus many companies choose the second approach (i.e., of using smallest batch size and largest daily dose for all products made in the same equipment) for that very reason.

One obvious requirement for this method of calculation is that in order to use it, there must be an established therapeutic dose. Not all potential contaminants have therapeutic doses. For example, there are no therapeutic or medical doses available for precursors, by-products of chemical synthesis, and cleaning agents (detergents), therefore a method of calculating limits is needed that is based on some parameter other than therapeutic dose. One method that can be used in these instances is based on the toxicity of the material.

## **XIX. CALCULATION OF LIMIT BASED ON TOXICITY**

This method of calculation is based on the use of animal toxicity data to determine limits. As mentioned earlier, this method is particularly suited for determining limits for materials that are not used medically. This method is based upon the concepts of acceptable daily intake (ADI) and no observed effect level (NOEL) developed by scientists in the Environmental Protection Agency [7], the U.S. Army Medical Bioengineering Research and Development Laboratory [8], and the toxicology department at Abbott Laboratories [9]. This method has also been recently used to calculate the limits of organic solvent residues allowed in APIs [10].

Basically, these workers were attempting to determine the amounts of chemicals that the human body could ingest on a daily basis without undue risk and toxicity. In the process, they found that a level of “acceptable daily intake” could be calculated from the toxicity of the materials expressed as an LD<sub>50</sub>. These data are widely available on material safety data sheets and other references on which toxicity data can be found.

The NOEL is calculated from the LD<sub>50</sub> by the mathematical relationship as follows:

$$\text{NOEL} = \text{LD}_{50} \times 0.0005$$

where the 0.0005 is a constant derived from a large toxicology database. Once the NOEL is known, then the ADI can be calculated by the relationship

$$\text{ADI} = \text{NOEL}/\text{SF}$$

where SF is an appropriate safety factor

Finally, the maximum allowable carryover (MACO) can be calculated from the relationship

$$\text{MACO} = \text{ADI} \times \text{B}/(\text{LDD})$$

where B is defined as the smallest batch size of any other product made in the same equipment

and LDD is the largest normal daily dosage of any product made in the same equipment.

As an example, consider a fictitious chemical substance, chemical X. If it is assumed that the following toxicity, batch size, and dosage information is known, then the MACO can be calculated as follows:

$$\begin{aligned} \text{LD}_{50} &= 419 \text{ mg/kg (oral)} \\ &\text{and } 85 \text{ mg/kg (IV)} \end{aligned}$$

Smallest batch size made in same equipment (B) = 40 kg

Largest normal daily dosage, LDD = 300 mg

$$\begin{aligned} \text{NOEL} &= 419 \text{ mg/kg} \times 0.0005 \\ &= 0.2095 \text{ mg/kg/day} \end{aligned}$$

For a normal adult of 70 kg

$$\text{NOEL} = 0.2095 \text{ mg/kg} \times 70 \text{ kg} = 14.665 \text{ mg}$$

$$\text{ADI} = \text{NOEL}/\text{SF}$$

Using a safety factor of 100 (for the oral route) gives

$$\text{ADI} = 14.665/100 = 0.147 \text{ mg}$$

$$\text{MACO} = \text{ADI} \times \text{B}/(\text{LDD}) = \frac{0.147 \times 40,000,000 \text{ mg}}{300 \text{ mg}}$$

or MACO = 19,600 mg or 19.6 g

Similar calculations for the intravenous (IV) route of administration are as follows:

$$\text{NOEL} = \text{LD}_{50} \times 0.0005 = 85 \text{ mg/kg} \times 0.0005 \times 0.0425 \text{ mg/kg/day}$$

Again, converting for a 70-kg adult weight gives the following:

$$\text{NOEL} = 0.0425 \text{ mg/kg/day} \times 70 \text{ kg} = 2.975 \text{ mg/day}$$

$$\text{ADI} = \text{NOEL}/\text{SF} = 2.975/5000 = 0.000595 \text{ mg/day}$$

(Note: the 5,000 represents a safety factor for the IV route of administration.)

$$\text{MACO} = \text{ADI} \times \text{B}/(\text{LDD}) = 0.000595 \times 40,000,000/200 = 119 \text{ mg}$$

This calculation illustrates a couple of additional points. First, the MACO calculation will utilize different  $\text{LD}_{50}$  values, depending on the route of administration of the other products manufactured in the same equipment. If all of the products manufactured in the equipment were used by the oral route of administration, then the limit used would be 19.6 g. If any of the products made in the same equipment were to be eventually incorporated into an IV dosage form, however, then the limit would be 119 mg (i.e., the more conservative of the two calculations).

Another important aspect of limits calculations is that the values calculated represent the total amount of allowable residue on all pieces of equipment in the manufacturing "train." Often, for practical and logistics purposes, it is necessary to divide or prorate the limit among the various pieces of equipment.

Table 6 illustrates how the limit is prorated for a specific manufacturing setup. In Table 6 it is apparent that the total limit is divided or proportioned based on its percentage of the total surface area.

**Table 6** Dividing a Total Residue Limit Among Various Pieces of Equipment

Name of equipment	Surface area (sq. ft.)	Percentage of total	Oral limit (grams)	IV limit (grams)
Manufacturing tank	23	6.34	1.24007	0.0075
Transfer tank	23	6.34	1.24007	0.0075
Holding tank	98	27.03	5.28378	0.0322
Centrifuge	45	12.41	2.42623	0.0148
Predryer	116	31.99	6.25428	0.0381
Dryer	28	7.72	1.50965	0.0092
Prefilter	27	7.45	1.45574	0.0089
Line filters	2.6	0.72	0.14018	0.0009
Totals	362.6	100%	19.5500	0.1190

If rinse sampling is used and the entire equipment is rinsed, then the limit can be used for the individual piece of equipment. If the equipment will be sampled by swab sampling, however, it is necessary to factor the limit even further. For example, if six areas of the manufacturing tank will be sampled by swab sampling and each swab will represent an area swabbed of 12 in. by 12 in., then the total area swabbed is 6 sq. ft. (Note: the total area of the equipment was 23 sq. ft.) The total allowable residue for all six swabs (summed together) would be:

$$\text{Limit for total area swabbed (oral)} = 6/23 \times 1.24007 = 0.3235 \text{ g}$$

$$\text{Limit for total area swabbed (IV)} = 6/23 \times 0.0075 = 0.002 \text{ g or 2 mg}$$

To determine the residue allowed per swab, it is necessary to divide these results by 6; therefore

$$\text{Limit for single swab (oral)} = 0.3235/6 = 0.0539 \text{ g or 54 mg}$$

$$\text{Limit for single swab (IV)} = 0.002/6 = 0.0003 \text{ g or 0.3 mg or 300 } \mu\text{g}$$

## **XX. CALCULATIONS FROM SWAB SAMPLING— A POTENTIAL PITFALL**

The manner in which the sampling data will be processed or calculated is normally specified in the protocol, either in the sampling section or in the acceptance criteria section. For rinse samples, the calculation of the data is quite straightforward since the amount of residue, after correction for recovery, is indicative of the amount of residue dispersed over the entire equipment. When the data are obtained by swabbing, however, there are several options that can be used for calculation purposes. As was emphasized previously, it is important to include swab samples from the most difficult to clean, worst-case locations in the equipment. It is equally important, in the author's experience, to include swab samples that are representative of all areas of the equipment, including the easy to clean locations. After all, a given piece of equipment may have 99% of its surface area in the readily accessible, easy to clean, visually friendly category. Often only 1% or less of the equipment surface area falls in the category of difficult to clean, yet when it comes to the calculations, we often are so conservative that we assume that the equipment is uniformly as "dirty" as the worst sample obtained. This does not seem reasonable or practical in terms of common sense. We are in essence saying that the small area of, for example, a gasket is less clean and therefore the entire equipment is as unclean as the gasket even though we can't clearly view the gasket contact area whereas we can

readily see the sides, top, bottom, and the rest of the equipment surface quite clearly.

The key to resolving this situation and not falling into the trap of being unrealistic is perhaps best illustrated by an example. We will calculate the overall residue remaining on a tank using only the data from the worst-case location. We will then repeat the same calculations using all of the data for the tank.

For purposes of the calculations, let's assume that we have a large tank equipped with a mixer, a valve, and a dip tube. Let's further assume that we have carried out the calculations and we know that our acceptance criteria allow us a total residue of 100 mg. The tank has a manway gasket that we have identified as a worst-case location, and in the first example we are going to base the entire test on the single worst-case location. Suppose we swab an area of 2 in. by 2 in. (total of 4 sq. in.) and on analysis we find there is 0.1 mg on the swab. If the tank has a total surface area of 100,000 sq. in. we could calculate the total residue on the tank using the data from the single swab as follows:

$$\text{Total residue} = \text{residue/square inch} \times 100,000 \text{ sq. in.}$$

$$\text{Residue/sq. in.} = 0.1 \text{ mg}/4 \text{ sq. in.} = 0.025 \text{ mg/sq. in.}$$

$$\text{Total residue} = 0.025 \text{ mg/sq. in.} \times 100,000 \text{ sq. in.} = 2500 \text{ mg}$$

The total residue of 2500 mg greatly exceeds our total allowable limit of 100 mg residue and we clearly fail the acceptance criteria.

We should ask ourselves, however, "Was the entire equipment really as soiled as the single worst-case location?" If so, then we clearly deserved to fail this test. Remember, however, that the gasket was "sandwiched" in between two stainless steel surfaces and was very difficult to access for cleaning purposes. Also, the gasket was not made of stainless steel but another more porous material, which could hold residue, and thus was more difficult to clean.

Let's revisit the cleaning of the tank and obtain samples from many different locations and choose sampling locations that fairly represent the entire equipment rather than just the single worst-case location. Let's assume that we still have the same total limit of 100 mg and that we still have the same tank having a total surface area of 100,000 sq. in. We still have the 0.1-mg swab for the manway gasket, but we now will take additional representative samples from each of several locations. Again we will swab areas of 2 in.  $\times$  2 in., just as we did previously. The data obtained are presented in [Table 7](#).

We have used the actual area of each section of the equipment and we have considered that each swab fairly represents the amount of residue in each individual section of the equipment. As noted in [Table 7](#), the total residue in this case is 49.25 mg, and this is quite a different result from the previous example, even though the same swab data (i.e., 0.1 mg) were used for the manway gasket. The significant point is that we obtained representative data for

**Table 7** Calculating Residues Using All Representative Samples

Location	Area of location	Amount per swab	Total residue at location
Manway gasket	200 sq. in.	0.1 mg	5 mg
Mixer blade	400 sq. in.	0.05 mg	5 mg
Dome of tank	20,000 sq. in.	0.002 mg	10 mg
Dip tube	200 sq. in.	0.03 mg	1.5 mg
Valve	200 sq. in.	0.01 mg	0.5 mg
Tank sides	59,000 sq. in.	0.001 mg	14.75 mg
Bottom of tank	20,000 sq. in.	0.0025 mg	12.5 mg
Totals	100,000 sq. in.		49.25 mg

each individual section of the equipment and processed the data separately, adding the results in the last step. It should also be noted that we are not “averaging” swab data, but instead are obtaining real representative data for each individual section of the equipment and adding the individual data to determine the total residue present in the entire equipment.

## **XXI. ADDITIONAL SPECIAL CLEANING ISSUES FOR ACTIVE PHARMACEUTICAL INGREDIENT (API) FACILITIES**

The manufacturers of APIs, also known as bulk pharmaceutical chemicals (BPCs), have several additional cleaning issues. Their processes are significantly different from those used for the manufacture of finished dosage forms. The manufacture of active ingredients is accomplished by chemical or biochemical synthesis. As such, these chemical or biochemical reactions involve precursors and intermediates in addition to the final chemical entity. These precursors and intermediates often have medical and/or toxic effects in humans and animals. It is thus often necessary to place limits on these materials for cleaning purposes. Further complicating the situation is that it is not possible to calculate limits for many of these chemical precursors and intermediates in the same way we calculate limits for cleaning in dosage form manufacturing facilities. As we saw in the previous section for calculating limits for dosage form facilities, a common approach is to base the limit on a fraction of the medical dose. This is not possible for API/BPC cleaning, however, since many of the chemical precursors and intermediates are not used medically and thus do not have medical doses. Since the chemical precursors and intermediates do not have medical doses, we must choose

a different approach to calculating limits, and we often choose to base the limits on the toxicity of the material. Various methods have been used for this purpose, such as basing the limit on a fraction of the smallest lethal dose or basing the limit on the NOEL approach that was discussed in the previous section.

Another cleaning issue unique to API/BPC manufacturers concerns the use of organic solvents. These solvents are often used as the solvent media for many of the chemical reactions. Because of the toxicity of many organic solvents it is necessary to address cleaning limits for these materials. Many API/BPC facilities have complex permanent piping configurations that do not allow visual or physical evaluation of product contact surfaces. Stated simply, it is not possible to see inside transfer pipe systems that may exceed 100 ft. in length and may or may not have low spots (traps). One approach that has been used to address this situation is to fill the reactor with a cleaning solvent and heat to the boiling point, thus allowing vapors of the solvent to rise in the pipes, condense, and flow back into the reactor. The theory is that the solvent would clean the pipes and “rinse” any residues back into the reactor where they could be removed by conventional cleaning methods.

One clever means of not having to consider the solvent as a cleaning agent (and thus having to prove its removal) is to look ahead in the schedule to determine the solvent to be used in the reactor for the next manufacturing event. A final rinse of the equipment with that “next-used” solvent means that the solvent is now considered as “process-related,” and it is not necessary to treat it as a cleaning agent or to prove its removal. This can mean a substantial savings in validation resources.

## **XXII. SPECIAL CLEANING ISSUES FOR STERILE PHARMACEUTICAL DOSAGE FORM FACILITIES**

In addition to the residues associated with active ingredients, excipients, and cleaning agents, a manufacturer of sterile pharmaceutical dosage forms must be concerned with additional possible residues, namely microbial residues, endotoxins, disinfectants, and sanitizing agents. Microbial and endotoxin residues are usually controlled and associated with the sterilization and manufacturing processes and only incidentally with the cleaning process. The one exception appears to be if water is allowed to remain on equipment for an inappropriately long time after cleaning and disinfecting. Stagnant water is usually the most prominent source of high counts for gram-negative bacteria. Water may pool and become stagnant, thus providing a growth medium for bacteria. The pooling may occur in obvious areas, such as the bottom of manufacturing vessels, or it may occur in less obvious areas, such as hoses that are stored improperly and have low points where water can remain in pools. Some bacterial will undoubtedly



remain on equipment after cleaning and prior to sterilization. The microbial “validation” effort should perhaps be directed toward the disinfection, sanitization, and sterilization processes. Also, since validation is only a “snapshot in time” of a process, it is possible for equipment to be within microbial limits at one point and subsequently fall out of limits as bacteria grow and counts increase. The real control of microbial levels on equipment will thus come mainly from the validation of the sterilization process coupled with the environmental monitoring program, which is a continuous long-term program.

### **XXIII. CLEANING ISSUES FOR OTHER PHARMACEUTICAL FACILITIES**

Cleaning and cleaning validation are also important for many other segments of the pharmaceutical industry. Manufacturers of excipients, medical devices, and diagnostics are examples of closely allied industries that must also consider how such GMP issues as cleaning apply to their business. Any cross-contaminant present in an excipient, for example, would likely lead to contamination of many pharmaceutical dosage forms utilizing that excipient since the contaminant might not be detected and removed during the manufacture of the dosage form. In a similar fashion, cleaning could be equally important for the manufacture of in vitro diagnostic products. Many of the diagnostic kits contain a control sample of drugs that were manufactured in the same facility and equipment as the test kit. Any cross-contamination could result in “false positive” test results, which would be a major problem and lead to misdiagnosis and unfortunate consequences.

### **XXIV. POSTVALIDATION ACTIVITIES REGARDING CLEANING**

*Monitoring*—Once a cleaning process has been validated, there is an inclination to feel that the cleaning process is adequate and has been proven, and that therefore there is no need to ever gather any additional cleaning data. It may be well to note that a process can fail even after validation. There can be changes in raw materials (e.g., cleaning agents) or in water systems or heat exchangers may become ineffective, and a host of other indirect causes may cause a previously good cleaning procedure to suddenly become inadequate or fail. It is always a good idea to periodically gather additional data to substantiate that a process continues to be effective. Since cleaning is considered a critical process, it is well to monitor the results with a certain frequency. The monitoring schedule

may be addressed in the CVMP or it may be a separate document, such as a quality assurance department policy. In some cases in which very potent or toxic materials are involved as starting materials, intermediates, or finished products, some companies choose to monitor the effectiveness of the cleaning process for each and every batch. While that degree of monitoring may not be necessary for every pharmaceutical product, it is a good idea to periodically monitor cleaning or every nth batch of product or after every Nth cleaning.

During the monitoring phase, it may be a very good idea to switch to a nonspecific analytical method such as TOC. This would allow the company to screen samples very quickly by a very sensitive analytical method. Even though TOC is nonspecific in nature, if higher than anticipated results were achieved, the company could do additional testing by a product-specific method. The TOC or other nonspecific method would thus be used as a “filter” to determine if there were cleaning problems, and if so, a more product-specific assay could be used to identify and confirm whether the residue was active ingredient, cleaning agent, excipient, or another material.

It should also be mentioned that during monitoring it is not necessary to sample all the locations that were sampled during the original validation. One common approach to sampling during monitoring is to sample only the worst-case, most difficult to clean locations. Another sampling philosophy is to switch from swab sampling to rinse sampling during the monitoring phase so that the “overall cleaning” is evaluated and no areas are missed, such as could occur with swab sampling. The feeling is that the most difficult to clean locations can be quickly evaluated by visual examination. This combination of rinse sampling and visual examination of equipment is quite effective as a monitoring program.

*Revalidation*—At some point it may be necessary to revalidate all processes, equipment, and people. Life in the pharmaceutical world is a constantly changing situation. Some changes may be planned while others are not. For example, we may plan to change a mixer in a tank and we may implement the appropriate change control documentation that ensures that the change will be carefully evaluated and tested as to impact upon validated processes.

There is also the slow and insidious type of change that occurs over long time periods, however. An example is the wearing of parts and equipment that occurs with normal use. At this point, someone usually points out that we have a preventive maintenance and calibration program that should take care of those changes that occur as a result of normal use. While it is true that the PM program is effective in dealing with many, if not most, of the changes, there may be some that slip

through the cracks. For example, consider that a process manufacturing tank begins life in the facility as very bright and shiny stainless steel. As time goes by, however, the normal use of the equipment results in many small scratches, dents, and imperfections in the surface of the tank. The author suggests that the scratched and dented surfaces will probably be more difficult to clean than the original shiny, smooth surfaces. As to the PM program, it is doubtful that the management would choose to remove and replace the tank just because of a few scratches.

Most processes and equipment speak to us in many ways, just as if they have voices. The early warning signs may come to us as a result of the monitoring program described in the previous section. For example, there may be atypical results that, although still in the acceptable range, are higher than we've seen previously. There may be control charts on the monitoring results that show that a trend is developing toward higher and higher amounts of residues. There may be problems appearing in the form of large numbers of deviations, holds, and rejections of products that appear during the annual product review process. These are all signals that something has changed, and it may be time to consider various remedies, among them revalidation.

On the other hand, some companies have a policy of revalidation tied to a calendar. For example, it may be the policy of a company to revalidate all processes, including cleaning, every certain number of years. In the author's opinion, this leads to the premature revalidation of many processes. It would be much better to review processes every 2 years, for example, and revalidate only those that need to be revalidated. In other words, "If it ain't broke, don't fix it."

*Cleaning issues for the laboratory*—An emerging cleaning issue that will be more prominent in future years is the cleaning of glassware and other laboratory equipment. If one imagines the possible influence, both positive and negative, on subsequent testing carried out with improperly or inadequately cleaned labware, it is obvious that any residues that carry over to the next use of the labware could undermine the validity of the results. In the author's opinion, we should thus give greater attention to the cleaning of such glassware as flasks, beakers, and pipettes, and to glass and quartz cells placed in instruments such as spectrophotometers. Fortunately, we usually carry out a "blank" determination to blank out these small sources of variation. In the case in which the blank is in a separate cell, however, this would not prevent interference from residues present in the primary cuvette. One can imagine other areas in which lack of validated cleaning could also be a problem. Another example is the dissolution flasks used to test solid oral dosage forms. What happens when these dissolution flasks are inadequately

cleaned? Again, the point that the author is trying to make is not that the labware is necessarily unclean, but rather to pose the question “Do we have the data to prove that the labware is clean?” A related question might be “Do we have the same detailed, written cleaning procedures for cleaning labware and instruments that we do for cleaning manufacturing equipment in the production areas of the facility?” These thoughts are meant to be food for thought only; however, the author fully expects the various regulatory agencies to eventually address this source of potential variation, especially with the current and future emphasis on the importance of the laboratory.

*Use of disposable equipment*—One very clever alternative to classic cleaning validation is to use disposable equipment. This can be cost-effective in both the manufacturing operations and the laboratory. For small, bench-scale manufacturing situations, it may be possible to utilize relatively inexpensive disposable glass equipment (e.g., glass round-bottom flasks) as the actual manufacturing vessels. This practice is actually fairly standard for chemical development, pharmaceutical development, and some small-scale biotech operations. It may often be easier to use disposable Tygon® tubing instead of trying to clean the tubing between products for a liquid product. Similarly, for packaging equipment it may be more economically feasible to use disposable filling needles than to attempt to effectively clean very narrow orifices. In the laboratory, there is certainly a trend toward using pipettes with disposable plastic tips rather than the original glass pipets. Also, it has been common practice for many years to use small, disposable plastic weighing “boats” to weigh out ingredients on an analytical balance.

## **XXV. SUMMARY AND CONCLUSIONS**

It is my hope that this chapter will be beneficial to the reader and that it will help you prepare or enhance a cleaning program that will meet current and future regulatory expectations. Without any doubt, cleaning has arrived as an important segment of your overall validation program. Without validation or other documented evidence we will not be able to convince others of the integrity and quality of our products and processes. Good luck and best wishes.

## **REFERENCES**

1. *United States v. Barr Laboratories*. Civil Action no. 92-1744. U.S. District Court for the District of New Jersey.
2. U.S. Department of Health and Human Services, Public Health Service, Food and

- Drug Administration. *Biotechnology Inspection Guide*. Washington, DC: U.S. Government Printing Office (Nov. 1991).
3. U.S. Department of Health and Human Services, Public Health Service, Food and Drug Administration. *Guide to Inspections of Cleaning*.
  4. U.S. Department of Health and Human Services, Public Health Service, Food and Drug Administration. *Guide to Inspection of Bulk Pharmaceutical Chemicals*. Washington, DC: U.S. Government Printing Office (Sept. 1991).
  5. Foreman, G. L., Mullen, M. V. *Pharm Tech* 17(4), (1993).
  6. LeBlanc, D. A. *Pharm Tech* (Oct. 1998).
  7. Dourson, M. L., Stara, J. F. *Reg Toxicol Pharm* 3(224), (1983).
  8. Layton, D. W., Mallon, B. J., Rosenblatt, D. H., Small, M. J. *Reg Toxicol Pharm* 7(96), (1987).
  9. Conine, D. L., Naumann, B. D., Hecker, L. H. *QA Gd Prac Reg Law*, 1(171), (1992).
  10. International Council on Harmonisation of Technical Requirements for Registration of Pharmaceuticals for Human Use. *Impurities: Guideline for Residual Solvents*. (July 1997).

# 15

## Validation of Analytical Methods and Processes

**Ludwig Huber**

*Agilent Technologies GmbH, Waldbronn, Germany*

### I. INTRODUCTION

Method validation is the process to confirm that the analytical procedure employed for a specific test is suitable for its intended use. Methods need to be validated or revalidated as follows:

- Before their introduction into routine use

- Whenever the conditions change for which the method has been validated (e.g., instrument with different characteristics)

- Whenever the method is changed, and the change is outside the original scope of the method

- When quality control indicates an established method is changing with time

- In order to demonstrate the equivalence between two methods (e.g., a new method and a standard)

Method validation has received considerable attention in the literature and from industrial committees and regulatory agencies. The international standard ISO/IEC [1] requires validation of nonstandard methods, laboratory designed/developed methods, standard methods used outside their intended scope, and amplifications and modifications of standard methods to confirm that the methods are suitable for their intended use. The *Guidance on the Interpretation of the EN 45000 Series of Standards and ISO/IEC Guide 25* includes a chapter on the validation of methods [2] with a list of nine validation parameters. The International Conference on Harmonization (ICH) of Technical Requirements for the

Registration of Pharmaceuticals for Human Use [3] has developed a consensus text on the validation of analytical procedures. The document includes definitions for eight validation characteristics. An extension with more detailed methodology is in preparation and nearly completed [4]. The U.S. Environmental Protection Agency (U.S. EPA) prepared a guidance for methods development and validation for the Resource Conservation and Recovery Act (RCRA) [5]. The American Association of Official Analytical Chemists (AOAC), the U.S. Environmental Protection Agency (EPA), and other scientific organizations provide methods that are validated through multilaboratory studies.

The U.S. Food and Drug Administration (U.S. FDA) has proposed guidelines on submitting samples and analytical data for methods validation [6–9]. The U.S. FDA has also published an industry guidance on bioanalytical methods validation [10]. The information in this guidance is generally applicable to the gas chromatography or high-pressure liquid chromatography analytical methods performed on drugs and metabolites obtained from such biological matrices as blood, serum, plasma, or urine. This guidance should also apply to other analytical techniques, such as immunological and microbiological methods or other biological matrices, such as tissue samples (including skin samples), although in these cases a higher degree of variability may be observed. The guidance is based primarily on the conference Analytical Methods Validation: Bioavailability, Bioequivalence, and Pharmacokinetic Studies, which was held for December 3 to December 5, 1990, and sponsored by the American Association of Pharmaceutical Scientists, FDA, Federation Internationale Pharmaceutique, the Canadian Health Protection Branch, and the AOAC [11].

The U.S. Pharmacopoeia (USP) has published specific guidelines for method validation for compound evaluation [12]. Eurachem has published an 82-page laboratory guide, *The Fitness for Purpose of Analytical Methods* [13].

Representatives of the pharmaceutical and chemical industry have published papers on the validation of analytical methods. Hokanson [14,15] applied the life-cycle approach developed for computerized systems to the validation and revalidation of methods. Green [16] gave a practical guide for analytical method validation with a description of a set of minimum requirements for a method. Renger and his colleagues [17] described the validation of a specific analytical procedure for the analysis of theophylline in a tablet using high-performance thin-layer chromatography (HPTLC). The validation procedure in that article is based on requirements for European Union multistate registration. Wegscheider [18] has published procedures for method validation with special focus on calibration, recovery experiments, method comparison, and investigation of ruggedness. The AOAC [19] has developed a peer-verified methods validation program with detailed guidelines on what parameters should be validated. Huber has published papers on the validation of HPLC methods [20] and on the evaluation and validation of standard methods [21].

Up-to-date information on the validation of analytical methods can also be found on the Internet. The most comprehensive information on new literature, regulations, and guidelines for method validation is available on [www.labcompliance.com](http://www.labcompliance.com). This site also has a tutorial on the basics of method validation.

This article gives a review and a strategy for the validation of analytical methods for both in-house-developed as well as standard methods and a recommendation on the documentation that should be produced during and at the end of method validation.

## II. STRATEGY FOR VALIDATION OF METHODS

The validity of a specific method should be demonstrated in laboratory experiments using samples or standards that are similar to the unknown samples analyzed in the routine. The preparation and execution should follow a validation protocol, preferably written in a step-by-step instruction format. Possible steps for a complete method validation are listed in Table 1.

First, the scope of the method and its validation criteria should be defined. These include

- Compounds
- Matrices
- Type of information (qualitative or quantitative)
- Detection and quantitation limits

**Table 1** Steps in Method Validation

- 
1. Develop a validation protocol or operating procedure for the validation.
  2. Define the application, purpose, and scope of the method.
  3. Define the performance parameters and acceptance criteria.
  4. Define validation experiments.
  5. Verify relevant performance characteristics of equipment.
  6. Qualify materials (e.g., standards and reagents).
  7. Perform prevalidation experiments.
  8. Adjust method parameters or/and acceptance criteria if necessary.
  9. Perform full internal (and external) validation experiments.
  10. Develop SOPs for executing the method in the routine.
  11. Define criteria for revalidation.
  12. Define type and frequency of system suitability tests and/or analytical quality control (AQC) checks for the routine.
  13. Document validation experiments and results in the validation report.
-



Linear range  
Precision and accuracy  
Type of equipment and location

The method's performance characteristics should be based on the intended use of the method. For example, if the method will be used for qualitative trace-level analysis, there is no need to test and validate the method's linearity over the full dynamic range of the equipment. Initial parameters should be chosen according to the analyst's best judgment. Finally, parameters should be agreed upon between the lab generating the data and the client using the data.

The scope of the method and its validation parameters and acceptance criteria should be defined early in the process. These include

- What analytes should be detected?
- What are the expected concentration levels?
- What are the sample matrices?
- Are there interfering substances expected and if so, should they be detected and quantified?
- Are there any specific legislative or regulatory requirements?
- Should information be qualitative or quantitative?
- What are the required detection and quantitation limits?
- What is the expected concentration range?
- What precision and accuracy is expected?
- How robust should the method be? For example, should the method work at a specific room temperature or should it run independently from room temperatures?
- Which type of instrument should be used? Is the method for one specific model from a specific vendor or should it be used by all models from all vendors? This is especially important for HPLC gradient methods, because different instruments may have different delay volumes, ranging from 0.5 up to 8 ml. This can have a tremendous impact on the separation and elution order of the compounds.
- Will the method be used in one specific laboratory or should it be applicable in all laboratories in your organization?
- What skills should the anticipated users of the method have?

The scope of the method should include the different types of equipment and the locations where the method will be run. For example, if the method is to be run on one specific instrument in one specific laboratory, there is no need to use instruments from other vendors or to include other laboratories in the validation experiments. In this way the experiments can be limited to what is really necessary.

Before an instrument is used to validate a method, its performance should be verified using generic standards [22,23]. Satisfactory results for a method can only be obtained with well-performing equipment. Special attention should be paid to the equipment characteristics that are critical for the method. For example, if detection limit is critical for a specific method, the instrument's specification for baseline noise and for certain detectors also the response to specified compounds should be verified. Any material used to determine critical validation parameters, such as reagents and reference standards, should be checked for accurate composition and purity.

If there is no or little information on the method's performance characteristics, it is recommended that the method's suitability for its intended use in initial experiments be proven. These studies should include the approximate precision, working range, and detection limits. If the preliminary validation data appear to be inappropriate, the method itself, the equipment, the analysis technique, or the acceptance limits should be changed. In this way method development and validation is an iterative process. For example, in liquid chromatography selectivity is achieved through selection of mobile-phase composition. For quantitative measurements the resolution factor between two peaks should be 2.5 or higher. If this value is not achieved, the mobile phase composition needs further optimization.

There are no official guidelines on the sequence of validation experiments, and the optimal sequence can depend on the method itself. For a liquid chromatographic method the sequence from [Table 2](#) has been proven to be useful.

The more time-consuming experiments such as accuracy and ruggedness are put toward the end. Some of the parameters listed under items 2 through 5 can be measured in combined experiments. For example, when the precision of peak areas is measured over the full concentration range, the data can be used to validate the linearity.

During method validation the parameters, acceptance limits, and frequency of ongoing system suitability tests or quality control checks should be defined. Criteria should be defined to indicate when the method and system are out of statistical control. The goal is to optimize these experiments in such a way that with a minimum number of control analyses the method and the complete analytical system will provide long-term results that will meet the objectives defined in the scope of the method.

A validation report should be prepared that includes

Description of the method.

Objective and scope of the method (applicability, type).

Summary of methodology, including sampling procedures.

Type of compounds and matrix.

**Table 2** Proposed Sequence of Validation Experiments, Example High Performance Liquid Chromatography

Validation parameters	Measurement methods
1. Specificity with standards	Sufficient separation of all compounds (resolution factor >2.5)
2. Linearity	Inject five standards containing the full working concentrations. Inject each standard three times. Average the peak area. Plot the averaged peak area vs. concentration. Calculate the linear regression.
3. Precision of the amounts	Inject a standard at three different concentrations five times. Calculate relative standard deviation of peak areas.
4. Accuracy	Spike a blank sample with the analyte at three different concentrations. Calculate the deviation of the results obtained with the method to be validated with the true value.
5. Intermediate precision	Inject three standards at different concentrations over 15 working days. The analysis should be conducted by three different operators using columns from three different batches. Measure the precision of amounts.
6. Limit of detection (LOD)	Inject a standard with a concentration close to the detection limit three times. Average signal height and baseline noise. $LOD = 3 \times \text{signal height} \times \text{standard amount/baseline noise}$
7. Limit of quantitation (LOQ)	Specify a precision limit for the amount at the limit of quantitation. Prepare six standard solutions with the amounts in the range from the expected limit of quantitation to 20 times this amount. Inject all samples six times and calculate the standard deviations of the amounts. Plot the standard deviations versus the amounts. Take the specified standard deviation at the corresponding LOQ amount from the plot.

**Table 2** *Continued*

Validation parameters	Measurement methods
8. Specificity with real samples	Use samples with analytes. Check peak purity with a diode-array detector and/or a mass selective detector. Run the sample under different chromatographic columns and/or with different columns.
9. Ruggedness	Check precision and accuracy in different laboratories
10. Robustness	Systematically change chromatographic conditions (examples: column temperature, flow rate, gradient composition, pH of mobile phase, detector wavelength). Check influence of parameters on separation and/or peak areas.

*Note:* For details see Ref. 20.

All chemicals, reagents, mobile phases, reference standards, quality control samples with purity, grade, their source, or detailed instructions on their preparation.

Procedures for quality checks of standards and chemicals used

Safety precautions.

A plan and procedure for method implementation from method development lab to routine.

Method parameters.

Critical parameters taken from robustness testing.

Listing of equipment and its functional and performance requirements (e.g., cell dimensions, baseline noise, column temperature range). For a complex equipment a picture or schematic diagrams may be useful.

Detailed conditions on how the experiments were conducted, including sample preparation. The report must be detailed enough to ensure that it can be reproduced by a competent technician with comparable equipment.

Statistical procedures and representative calculations.

Procedures for quality control in the routine (e.g., system suitability tests) with acceptance criteria.

Representative plots (e.g., chromatograms, spectra, and calibration curves).

Method-acceptance limit performance data.

The expected uncertainty of measurement results.

Criteria for revalidation.

The person who developed and initially validated the method.

References (if any).

Approval with names, titles, date, and signature of those responsible for the review and approval of the analytical test procedure.

### **III. VALIDATION OF STANDARD METHODS**

A laboratory applying a specific method should have documentary evidence that the method has been appropriately validated: “The responsibility remains firmly with the user to ensure that the validation documented in the method is sufficiently complete to meet his or her needs” [2]. This holds for standard methods (e.g., from EPA, ASTM, ISO, or USP), as well as for methods developed in-house. If standard methods are used, it should be verified that the scope of the method and validation data (e.g., sample matrix, linearity, range, and detection limits) comply with the laboratory’s analyses requirements; otherwise, the validation of the standard method should be repeated using the laboratory’s own criteria. The laboratory should demonstrate the validity of the method in the laboratory’s environment.

Full validation of a standard method is recommended where no information on type and results of validation can be found in the standard method documentation.

### **IV. REVALIDATION**

Operating ranges should be defined for each method based on experience with similar methods, or they should be investigated during method developments. These ranges should be verified during method validation in robustness studies and should be part of the method characteristics. The availability of such operating ranges makes it easier to decide when a method should be revalidated. A revalidation is necessary whenever a method is changed and the new parameter is outside the operating range. If, for example, the operating range of the column temperature has been specified to be between 30–40°C, the method should be revalidated if, for whatever reason, the new operating parameter has been selected as 41°C. Revalidation is also required if the sample matrix changes and if the instrument type changes; for example, if a brand with significantly different instrument characteristics is used. For example, a revalidation is necessary if a high-performance liquid chromatographic method has been developed and

validated on a pump with a delay volume of 5 ml and the new pump only has 0.5 ml.

Part or full revalidation may also be considered if system suitability tests or the results of quality control sample analysis are out of preset acceptance criteria and the source of the error cannot be tracked back to instruments or anything else.

## V. PARAMETERS FOR METHOD VALIDATION

The parameters for method validation have been defined in different working groups of national and international committees and are described in the literature. Unfortunately some of the definitions are different between different organizations. An attempt for harmonization was made for pharmaceutical applications through the ICH [3,4], at which representatives from industry and regulatory agencies from the United States, Europe, and Japan defined parameters, requirements, and to some extent methodology for analytical methods validation. The parameters as defined by the ICH and other organizations and authors are summarized in Table 3 and are described in brief in the following paragraphs.

**Table 3** Possible Parameters for Method Validation

---

Specificity <sup>a</sup>
Selectivity
Precision <sup>a</sup>
Repeatability <sup>a</sup>
Intermediate precision <sup>a</sup>
Reproducibility <sup>b</sup>
Accuracy <sup>a</sup>
Trueness
Bias
Linearity <sup>a</sup>
Range <sup>a</sup>
Limit of detection <sup>a</sup>
Limit of quantitation <sup>a</sup>
Robustness <sup>b</sup>
Ruggedness

---

<sup>a</sup>Included in ICH publications.

<sup>b</sup>Terminology included in ICH publications but are not part of required parameters.

## VI. SELECTIVITY AND SPECIFICITY

The terms *selectivity* and *specificity* are often used interchangeably. A detailed discussion of these terms as defined by different organizations has been made by Vessmann [24]. He particularly pointed out the difference between specificity as defined by the International Union of Pure and Applied Chemistry, the Western European Laboratory Accreditation Conference (IUPAC/WELAC), and ICH.

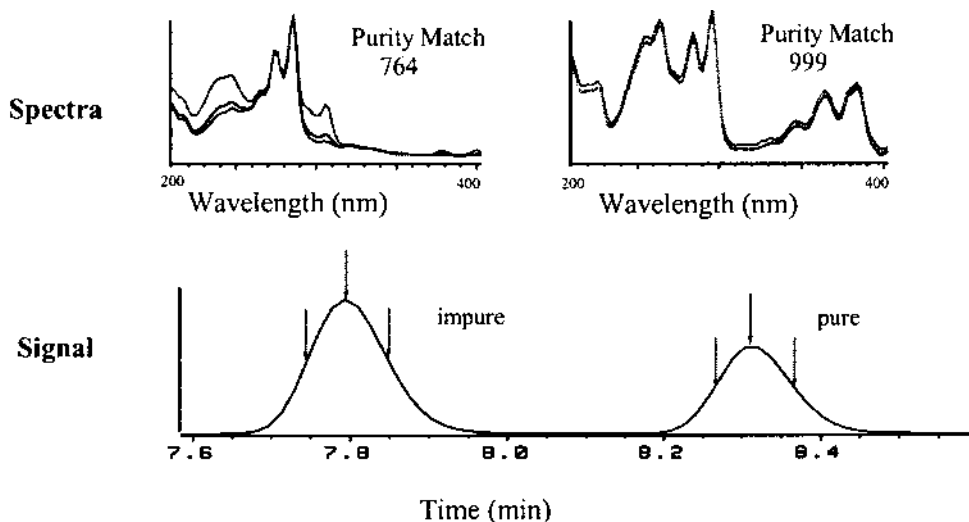
Even inconsistent with ICH, the term *specific* generally refers to a method that produces a response for a single analyte only while the term *selective* refers to a method that provides responses for a number of chemical entities that may or may not be distinguished from each other. If the response is distinguished from all other responses, the method is said to be selective. Since there are very few methods that respond to only one analyte, the term *selectivity* is usually more appropriate. The USP monograph [8] defines selectivity of an analytical method as its ability to measure accurately an analyte in the presence of interference, such as synthetic precursors, excipients, enantiomers, and known (or likely) degradation products that may be expected to be present in the sample matrix. Selectivity in liquid chromatography is obtained by choosing optimal columns and setting chromatographic conditions, such as mobile phase composition, column temperature, and detector wavelength.

It is a difficult task in chromatography to ascertain whether the peaks within a sample chromatogram are pure or consist of more than one compound. While in the past chromatographic parameters such as mobile phase composition or the column have been modified, nowadays the application of spectroscopic detectors coupled online to the chromatograph are used. Ultraviolet (UV)-visible diode-array detectors and mass spectrometers acquire spectra online throughout the entire chromatogram. The spectra acquired during the elution of a peak are normalized and overlaid for graphical presentation. If the normalized spectra are different, the peak consists of at least two compounds.

The principles of diode-array detection in HPLC and their application and limitations to peak purity are described in the literature [25–27]. Examples of pure and impure HPLC peaks are shown in Figure 1. While the chromatographic signal indicates no impurities in either peak, the spectral evaluation identifies the peak on the left as impure. The level of impurities that can be detected with this method depends on the spectral difference, on the detector's performance, and on the software algorithm. Under ideal conditions, peak impurities of 0.05–0.1% can be detected.

## VII. PRECISION AND REPRODUCIBILITY

The precision of a method is the extent to which the individual test results of multiple injections of a series of standards agree. The measured standard deviation can be subdivided into three categories: repeatability, intermediate preci-



**Figure 1** Examples of pure and impure HPLC peaks. The chromatographic signal does not indicate any impurity in either peak. Spectral evaluation, however, identifies the peak on the left as impure.

sion, and reproducibility [2,3]. Repeatability is obtained when the analysis is carried out in one laboratory by one operator using one piece of equipment over a relatively short timespan. At least

- Five or six determinations of
- Three different matrices at
- Two or three different concentrations

should be done and the relative standard deviation calculated. The acceptance criteria for precision depend very much on the type of analysis. While for compound analysis in pharmaceutical quality a control precision of better than 1% RSD is easily achieved, for biological samples the precision is more like 15% at the concentration limits and 10% at other concentration levels. For environmental and food samples, the precision is very much dependent on the sample matrix, the concentration of the analyte, and the analysis technique. It can vary between 2% and more than 20%.

The AOAC manual for the peer-verified methods program [16] includes a table (see Table 4) with estimated precision data as a function of analyte concentration.

Intermediate precision is a term that has been defined by ICH [3] as the long-term variability of the measurement process and is determined by compar-



**Table 4** Analyte Concentration Versus Precision Within or Between Days

Analyte (%)	Analyte ratio	Unit	RSD (%)
100	1	100%	1.3
10	10 <sup>-1</sup>	10%	1.8
1	10 <sup>-2</sup>	1%	2.7
0.1	10 <sup>-3</sup>	0.1%	3.7
0.01	10 <sup>-4</sup>	100 ppm	5.3
0.001	10 <sup>-5</sup>	10 ppm	7.3
0.0001	10 <sup>-6</sup>	1 ppm	11
0.00001	10 <sup>-7</sup>	100 ppb	15
0.000001	10 <sup>-8</sup>	10 ppb	21
0.0000001	10 <sup>-9</sup>	1 ppb	30

Source: Ref. 19.

ing the results of a method run within a single laboratory over a number of weeks. A method's intermediate precision may reflect discrepancies in results obtained by different operators, from different instruments, with standards and reagents from different suppliers, with columns from different batches, or by a combination of these. The objective of intermediate precision validation is to verify that in the same laboratory the method will provide the same results once the development phase is over.

Reproducibility as defined by ICH [2,3] represents the precision obtained between laboratories (Table 5). The objective is to verify that the method will provide the same results in different laboratories. The reproducibility of an analytical method is determined by analyzing aliquots from homogeneous lots in

**Table 5** Typical Variations Affecting a Method's Reproducibility

Differences in room temperature and humidity
Operators with different experience and thoroughness
Equipment with different characteristics (e.g., delay volume of an HPLC system)
Variations in material and instrument conditions (e.g., in HPLC, mobile phases composition, pH, flow rate of mobile phase)
Equipment and consumables of different ages
Columns from different suppliers or different batches
Solvents, reagents, and other materials with different quality

different laboratories with different analysts and by using operational and environmental conditions that may differ from but are still within the specified parameters of the method (interlaboratory tests). Validation of reproducibility is important if the method will be used in different laboratories.

## VIII. ACCURACY AND RECOVERY

The accuracy of an analytical method is the extent to which test results generated by the method and the true value agree. The true value for accuracy assessment can be obtained in several ways.

One alternative is to compare the results of the method with results from an established reference method. This approach assumes that the uncertainty of the reference method is known. Second, accuracy can be assessed by analyzing a sample with known concentrations (e.g., a certified reference material) and comparing the measured value with the true value as supplied with the material. If such certified reference material is not available, a blank sample matrix of interest can be spiked with a known concentration by weight or volume. After extraction of the analyte from the matrix and injection into the analytical instrument, its recovery can be determined by comparing the response of the extract with the response of the reference material dissolved in a pure solvent. Because this accuracy assessment measures the effectiveness of sample preparation, care should be taken to mimic the actual sample preparation as closely as possible.

The concentration should cover the range of concern and should particularly include one concentration close to the quantitation limit. The expected recovery depends on the sample matrix, the sample processing procedure, and the analyte concentration. The AOAC manual for the peer-verified methods program [16] includes a table (see [Table 6](#)) with estimated recovery data as a function of analyte concentration.

## IX. LINEARITY AND CALIBRATION CURVE

The linearity of an analytical method is its ability to elicit test results that are directly, or by means of well-defined mathematical transformation, proportional to the concentration of analytes in samples within a given range. Linearity is determined by a series of three to six injections of five or more standards whose concentrations span 80–120% of the expected concentration range. The response should be—directly or by means of a well-defined mathematical calculation—proportional to the concentrations of the analytes. A linear regression equation applied to the results should have an intercept not significantly differ-

**Table 6** Analyte Recovery at Different Concentrations

Active ingredient (%)	Analyte ratio	Unit	Mean recovery (%)
100	1	100%	98–102
>=10	10 <sup>-1</sup>	10%	98–102
>=1	10 <sup>-2</sup>	1%	97–103
>=0.1	10 <sup>-3</sup>	0.1%	95–105
0.01	10 <sup>-4</sup>	100 ppm	90–107
0.001	10 <sup>-5</sup>	10 ppm	80–110
0.0001	10 <sup>-6</sup>	1 ppm	80–110
0.00001	10 <sup>-7</sup>	100 ppb	80–110
0.000001	10 <sup>-8</sup>	10 ppb	60–115
0.0000001	10 <sup>-9</sup>	1 ppb	40–120

Source: Ref. 19.

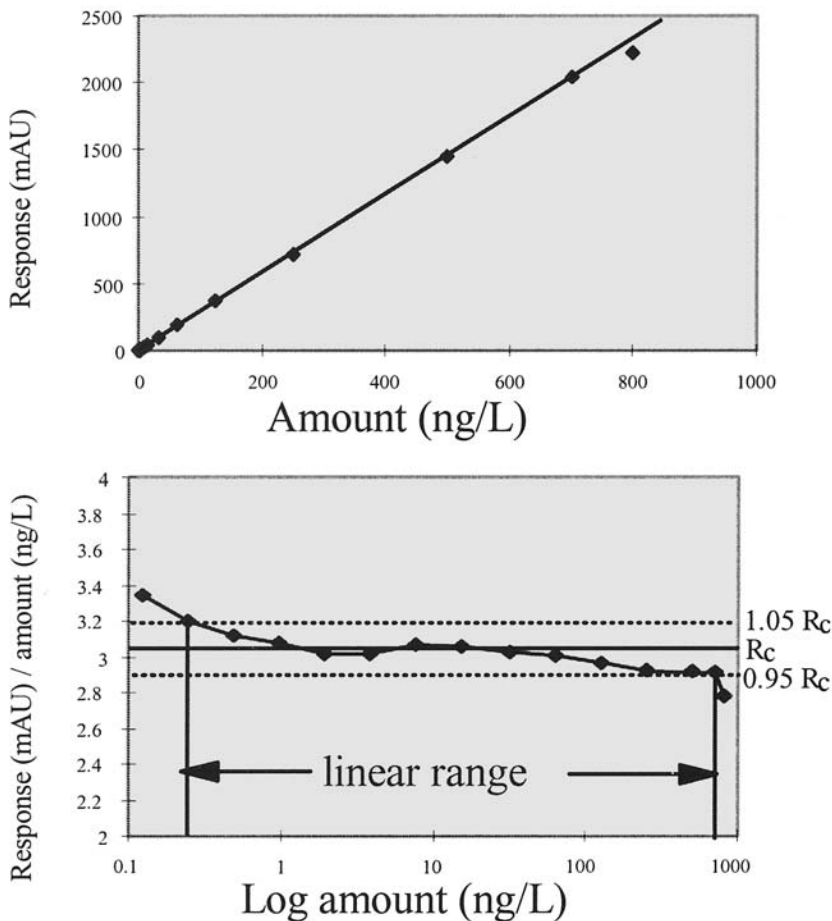
ent from zero. If a significant nonzero intercept is obtained, it should be demonstrated that there is no effect on the accuracy of the method.

Frequently the linearity is evaluated graphically in addition or alternatively to mathematical evaluation. The evaluation is made by visual inspection of a plot of signal height or a peak area as a function of analyte concentration. Because deviations from linearity are sometimes difficult to detect two additional graphical procedures can be used. The first one is to plot the deviations from the regression line versus the concentration or versus the logarithm of the concentration if the concentration range covers several decades. For linear ranges the deviations should be equally distributed between positive and negative values.

Another approach is to divide signal data by their respective concentrations yielding the relative responses. A graph is plotted with the relative responses on the Y axis and the corresponding concentrations on the X axis on a log scale. The obtained line should be horizontal over the full linear range. At higher concentrations there will typically be a negative deviation from linearity. Parallel horizontal lines are drawn in the graph corresponding to, for example, 95% and 105% of the horizontal line. The method is linear up to the point at which the plotted relative response line intersects the 95% line. [Figure 2](#) shows a comparison of the two graphical evaluations on the example of caffeine using HPLC.

## X. RANGE

The range of an analytical method is the interval between the upper and lower levels (including these levels) that have been demonstrated to be determined with precision, accuracy, and linearity using the method as written. The range



**Figure 2** Graphical presentations of linearity plot of a caffeine sample using HPLC. Plotting the sensitivity (response/amount) gives a clear indication of the linear range. Plotting the amount on a logarithmic scale has a significant advantage for wide linear ranges.  $R_c$  = line of constant response.

is normally expressed in the same units as the test results (e.g., percentage, ppm) obtained by the analytical method.

## XI. LIMIT OF DETECTION AND QUANTITATION

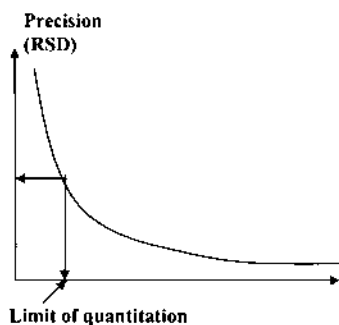
The limit of detection is the point at which a measured value is larger than the uncertainty associated with it. It is the lowest concentration of analyte in a sample that can be detected but not necessarily quantified. In chromatography

the detection limit is the injected amount that results in a peak with a height at least twice or three times as high as the baseline noise level.

The limit of quantitation is the minimum injected amount that gives precise measurements, in chromatography typically requiring peak heights 10 to 20 times higher than baseline noise (Fig. 3). If the required precision of the method at the limit of quantitation has been specified, the Eurachem [2] approach can be used. A number of samples with decreasing amounts of the analyte are injected six times. The calculated RSD of the precision is plotted against the analyte amount. The amount that corresponds to the previously defined required precision is equal to the limit of quantitation.

## XII. ROBUSTNESS

Robustness tests examine the effect operational parameters have on the analysis results. For the determination of a method's robustness a number of chromatographic parameters (e.g., flow rate, column temperature, injection volume, detection wavelength, or mobile phase composition) are varied within a realistic range and the quantitative influence of the variables is determined. If the influence of the parameter is within a previously specified tolerance the parameter is said to be within the method's robustness range. Obtaining data on these effects will allow us to judge whether or not a method needs to be revalidated when one or more of its parameters are changed; for example, to compensate for column performance over time. The ICH document [3] recommends considering the evaluation of a method's robustness during the development phase, but it is not required to be included as part of a registration application.



- Define expected precision for limit of quantitation.
- Prepare spiked matrix samples.
- Dilute and inject six times.
- Calculate RSD for each concentration.
- Plot precision vs. concentration.
- Concentration at expected precision = limit of quantitation.

**Figure 3** Limit of quantitation with the Eurachem method.

## REFERENCES

1. ISO/IEC 17025. International standard: General requirements for the competence of testing and calibration laboratories. Geneva, Switzerland (1999).
2. Eurachem. Guidance document no. 1/WELAC guidance document no. WGD 2: *Accreditation for Chemical Laboratories: Guidance on the Interpretation of the EN 45000 Series of Standards and ISO/IEC Guide 25* (1993); available from the Eurachem Secretariat, PO Box 46, Teddington, Middlesex, TW11 ONH, UK.
3. International Conference on Harmonization (ICH) of Technical Requirements for the Registration of Pharmaceuticals for Human Use. *Validation of Analytical Procedures: Definitions and Terminology*. ICH-Q2A, Geneva (1995); (CPMP/ICH/381/95), Internet: <http://www.fda.gov/cder/guidance/ichq2a.pdf>.
4. International Conference on Harmonization (ICH) of Technical Requirements for the Registration of Pharmaceuticals for Human Use. *Validation of Analytical Procedures: Methodology*. ICH-Q2B, Geneva (1996); (CPMP/ICH/281/95), Internet: <http://www.nihs.gov/drug/validation/q2bwww.html>.
5. U.S. Environmental Protection Agency. *Guidance for Methods Development and Methods Validation for the Resource Conservation and Recovery Act (RCRA) Program*. Washington, DC (1995).
6. U.S. Food and Drug Administration. *Technical Review Guide: Validation of Chromatographic Methods*. Rockville, MD: Center for Drug Evaluation and Research (CDER) (1993).
7. U.S. Food and Drug Administration. *General Principles of Validation*. Rockville, MD: Center for Drug Evaluation and Research (CDER), (May 1987).
8. U.S. Food and Drug Administration. *Guidelines for Submitting Samples and Analytical Data for Method Validation*. Rockville, MD: Center for Drugs and Biologics Department of Health and Human Services (Feb. 1987).
9. U.S. Food and Drug Administration. *Industry Draft Guidance Analytical Procedures and Methods Validation Chemistry, Manufacturing, and Controls Documentation* (Aug. 2000).
10. U.S. Food and Drug Administration. *Guidance: Bioanalytical Methods Validation for Human Studies* (2001); Internet: <http://www.fda.gov/cder/guidance/4252fn1.pdf>.
11. Shah, P. et al. Analytical methods validation: Bioavailability, bioequivalence and pharmacokinetic studies. *Eur J Drug Metab Pharmacol* 16(4): 249–255 (1989) (1991) and *Pharm Res* 9:588–592 (1992).
12. General Chapter <1225>: Validation of compendial methods. *United States Pharmacopeia XXIII*, National Formulary, XVIII. Rockville, MD: U.S. Pharmacopeial Convention, pp. 1710–1612 (1995).
13. Eurachem. *The fitness for Purpose of Analytical Methods* (Feb. 1998): available from the Eurachem Secretariat, PO Box 46, Teddington, Middlesex, TW11 ONH, UK.
14. Hokanson, G. C. A life cycle approach to the validation of analytical methods during pharmaceutical product development, part I: The initial validation process. *Pharm Tech* 118–130 (Sept. 1994).
15. Hokanson, G. C. A life cycle approach to the validation of analytical methods during pharmaceutical product development, part II: Changes and the need for additional validation. *Pharm Tech* 92–100 (Oct. 1994).

16. Green, J. M. A practical guide to analytical method validation. *Anal Chem News Feat 305A/309A* (May 1, 1996).
17. Renger, B., Jehle, H., Fischer, M., and Funk, W. Validation of analytical procedures in pharmaceutical analytical chemistry: HPTLC assay of theophylline in an effervescent tablet. *J Planar Chrom 8*: 269–278 (July/Aug. 1995).
18. Wegscheider, Validation of analytical methods. In: H. Guenzler, ed. *Accreditation and Quality Assurance in Analytical Chemistry*. Berlin: Springer Verlag (1996).
19. Association of Official Analytical Chemists. *Peer Verified Methods Program: Manual on Policies and Procedures*. Arlington, VA (Nov. 1993).
20. Huber, L. Validation of HPLC methods. *BioPharm 12*:64/66 (March 1999).
21. Huber, L. Evaluation and Validation of Standard Methods, Pharmaceutical Technology Analytical Validation Supplement to Pharmaceutical Technology. 6–8 (Feb. 1998).
22. Huber, L. *Validation and Qualification in the Analytical Laboratory*. Buffalo Grove, IL: Interpharm (1998).
23. Huber, L. *Validation of Computerized Analytical Systems*. Buffalo Grove, IL: Interpharm (1995).
24. Vessman, J. L. Selectivity or specificity? Validation of analytical methods from the perspective of an analytical chemist in the pharmaceutical industry. *J Pharm Biomed Anal 14*:867/869 (1996).
25. Huber, L. *Applications of Diode-Array Detection in HPLC*. Waldbronn, Germany: Agilent Technologies (1989), publ. number 12-5953-2330.
26. Marr, D., Horvath, P., Clark, B. J., Fell, A. F. Assessment of peak homogeneity in HPLC by computer-aided photodiode-array detection, *Anal Proceed 23*:254–257 (1986).
27. Huber, L., George, S. *Diode-Array Detection in High-Performance Liquid Chromatography*. New York: Marcel Dekker (1993).

# 16

## Computer System Validation: Controlling the Manufacturing Process

**Tony de Claire**

*APDC Consulting, West Sussex, England*

### I. INTRODUCTION

Pharmaceutical product research, development, manufacturing, and distribution require considerable investment in both time and money, and computerization has become key to improving operational efficiency. Computer system application is expected to support the fundamental requirement of minimizing risk to product identity, purity, strength, and efficacy by providing consistent and secure operation and reducing the potential of human error. From the regulatory and business viewpoint, the advantages of utilizing computer systems can only be realized by ensuring that each system does what it purports to do in a reliable and repeatable manner.

The objective of this chapter is to examine computer system qualification as required for validation programs in the regulated pharmaceutical industry, providing guidance and reference on regulatory requirements, validation methodologies, and documentation.

The good manufacturing practice (GMP) regulations in focus are from the U.S. Code of Federal Regulations (CFRs) [1,13], as inspected and enforced by the Food and Drug Administration (FDA), and Annex 11 of the European Community (EC) *Guide to Good Manufacturing Practice for Medicinal Products* [2].

The validation methodology presented is consistent with that presented in the *Supplier Guide for Validation of Automated Systems in Pharmaceutical*



*Manufacture*, GAMP Forum/ISPE [3], the Parenteral Drug Association (PDA) technical report *Validation of Computer-Related Systems* [4], and the ISPE *Baseline Guide for Commissioning and Qualification* [5]. A number of issues that are fundamental to application engineering a computer system for controlling a manufacturing process are also addressed, and the required relationship to the validation life cycle is examined.

To consider the close links with the manufacturing process this chapter will focus throughout on computer systems and the associated field input/output instrumentation required for the direct control and monitoring of the manufacturing process. Here the traditional demarcation between “real-time” and “information” systems is fast disappearing with process control and automation systems now capable of providing significant levels of data processing and management for pharmaceutical manufacturing.

### **A. Validation Policy Considerations**

Over the years regulatory authorities have identified three major concerns regarding computer system application.

Does the system perform accurately and reliably?

Is the system secure from unauthorized or inadvertent changes?

Does the system provide adequate documentation of the application?

With this in mind and to achieve and maintain validated computer systems, pharmaceutical manufacturers need to include the following as part of their compliance policy:

The master validation plan for each site must identify all computer systems operating in a GMP environment.

Computer system validation activities must ensure that all computer systems operating on the GMP environment perform consistently to the required standards.

All validation document preparation and activities must be performed in accordance with predefined and approved procedures.

The integrity of quality-related critical parameters and data must be maintained throughout each phase of the validation life cycle, including the supplier design and development phases.

Sites must operate a validation maintenance regime incorporating change control and revalidation programs.

## **II. REGULATORY BACKGROUND**

### **A. Good Manufacturing Practice**

The World Health Organization GMP [6] concept requires that critical processes should be validated, with validation defined as the documented act of proving

that any procedure, process, equipment, material, activity, or system actually leads to the expected results. The pharmaceutical manufacturer is expected to adopt current good practices to support evolving process and technology developments.

## **B. Regulations**

Examples of the U.S. regulations applicable to computer system application in a GMP environment are shown in [Table 1](#). The FDA also publishes compliance policy guides [7] related to pharmaceutical drug products and views the guidance provided on related products (e.g., medical devices [8]) to be “current” good manufacturing practice that should be considered for comparative GMP applications.

For the EC *Guide to Good Manufacturing Practice for Medicinal Products*, Annex 11 [2] identifies the following requirements that need to be addressed for computerized system application:

- GMP risk assessment
- Qualified/trained resource
- System life-cycle validation
- System environment
- Current specifications
- Software quality assurance
- Formal testing/acceptance
- Data entry authorization
- Data plausibility checks
- Communication diagnostics
- Access security
- Batch release authority
- Formal procedures/contracts
- Change control
- Electronic data hardcopy
- Secure data storage
- Contingency/recovery plans
- Maintenance plans/records

## **C. Validation**

Good manufacturing practice regulations identify what controls must be in place and adhered to in order to be in compliance, but do not provide instruction on how to implement these controls. The methods used to ensure the product meets its defined requirements are the responsibility of the pharmaceutical manufacturer, who must be prepared to demonstrate GMP compliance with validated systems and formal records.

**Table 1** Examples of U.S. Regulations Applicable to Computer Systems

CFR	Title	System Impact
People		
21 CFR 211. 25	Personnel qualifications	Qualifications, training, and experience for assigned functions
21 CFR 211. 34	Consultants	Qualifications, training, and experience to provide the service Record qualifications and work undertaken.
Hardware		
21 CFR 211. 63	Equipment design, size, and location	System design, capacity, and operating environment
21 CFR 211. 67	Equipment cleaning and maintenance	Preventative maintenance program at appropriate intervals, to formal procedures identifying responsibilities, schedule, tasks
21 CFR 211. 68 (a)	Automatic, mechanical, and electronic equipment	System reliability, with routine calibration, inspection or checks to formal maintenance procedures; results to be documented.

## Software

21 CFR 211. 68 (a), (b)	Automatic, mechanical, and electronic equipment	Accuracy, repeatability, and diagnostics Application software documentation Configuration management Access security Input/output signal accuracy and device calibration Data storage Software backup, archiving, and retrieval
21 CFR 211. 100	Written procedures: deviations	Formal approved and documented procedures (software) Deviation reporting
21 CFR 211. 101 (d)	Charge-in of components	Automated component addition verification
21 CFR 211. 180 (a), (c), (d), (e)	General requirements (records and reports)	Data record availability, retention, storage medium, and reviews
21 CFR 211. 182	Equipment cleaning and use log	Maintenance records
21 CFR 211. 186 (a), (b)	Master production and control records	Application software documentation
21 CFR 211. 188 (a), (b)	Batch production and control records	Data reproduction accuracy Documented verification of process steps Operator identification
21 CFR 211. 192	Production record review	Data record review by quality control
21 CFR 11	Electronic records; electronic signatures	Electronic record/signature type, use, control, and audit trail
FD&C Act, Section 704 (a)	Inspection	Access to computer programs

---

Source: Refs. 1, 13.

Validation is a process that involves planned activities throughout the life cycle of the computerized operation.

The recognized methods of conducting validation are outlined below.

Prospective validation, which includes all main validation phase approvals by means of design qualification (DQ), including specification reviews, installation qualification (IQ), operational qualification (OQ), performance qualification (PQ), and ongoing evaluation.

Retrospective validation, which may be conducted when sufficient historical records are available to demonstrate controlled and consistent operation (e.g., historical process data, problem logs, change control records, and test and calibration documentation).

Concurrent validation, in which documented evidence is generated during the actual operation of the process, is sometimes adopted in clinical supply situations in which only limited material is available for the trials.

Whatever the validation approach, the fundamental requirement for computer system validation is to establish documented evidence that provides a high degree of assurance that the system consistently operates in accordance with predetermined specifications. The EC guide to GMP also requires periodic critical revalidation to be considered to ensure processes and procedures remain capable of achieving the intended results.

For new applications or projects a prospective validation based on a recognized life cycle is the most effective and efficient approach. The life-cycle methodology can also be adapted for existing systems that do not have adequate documented records to support a retrospective validation.

Industry groups and regulatory authorities have debated and addressed the issues surrounding computer system validation, with the PDA [4] and GAMP Forum [3] providing industry guidance on validation life-cycle methodology and documentation.

Furthermore, the ISPE *Baseline Guide, Commissioning and Qualification* [5] emphasises the need to undertake qualification practices only for equipment and system component parts and functions that could directly impact quality attributes of a product or process. Other components and functions are to be dealt with under good engineering practice (GEP) [3,5] throughout the system life cycle, undergoing an appropriate level of documented commissioning.

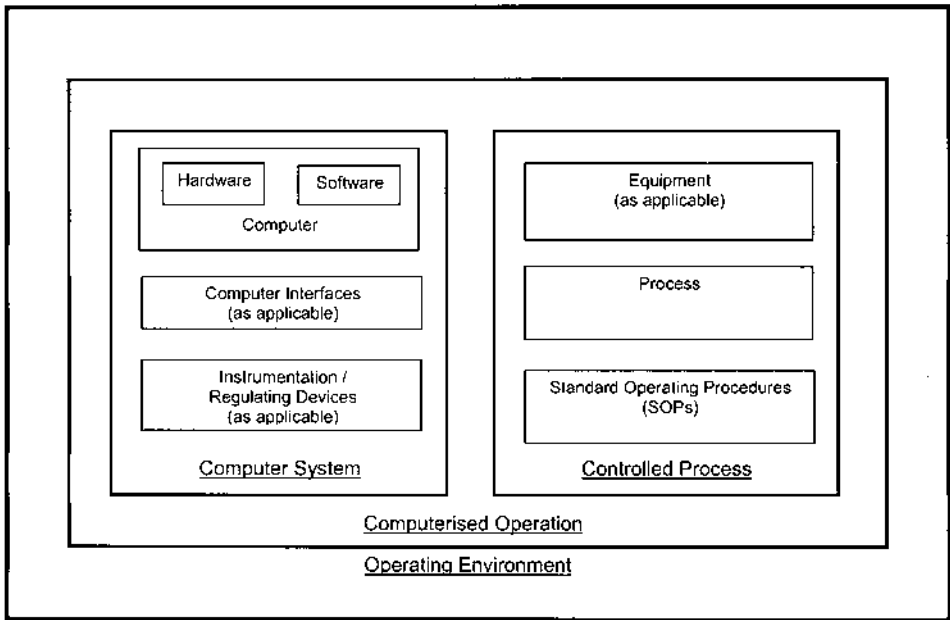
## **D. Computerized Operation**

The computer systems that can directly impact the quality attributes of pharmaceutical drug products and associated production records include a wide range of applications. Typically candidate systems can include real-time process control/

manufacturing automation systems (as examined herein), analytical systems, laboratory information systems, environmental management systems, process management information systems, material management, warehousing and distribution systems, document management systems, and maintenance systems.

Within the scope of validation for an automated facility or plant, the computer system is a component part of the facility GMP operation. The components of this computerized operation are illustrated in Figure 1, which depicts the composition of the computer system and the operation that it controls and monitors. In the case of real-time applications for primary (bulk) production process control systems and automated secondary manufacturing systems this will normally encompass the associated field instrumentation and electrical and pneumatic regulating devices (actuated valves, motor controls) and interconnecting cabling/wiring/piping. Together with the production/manufacturing equipment, the process and approved standard operating procedures (SOPs) are elements of a computerized operation.

The operating environment within which the computerized operation must function represents the defined work flow and support procedures between peo-



**Figure 1** Computerized operation model.

ple and the computerized operation and typically encompasses the following controls and procedures:

- System incident log
- System maintenance program
- Instrument calibration schedule
- Environmental conditions
- Support utilities and services
- Security management
- Change control
- Configuration management
- Inventory control
- Document control
- Internal audit
- Training program
- Contingency/recovery plans
- Validation documentation file

To maintain control of the computer system throughout its conception, implementation, and operational use in a GMP environment, it is required that the computer system application must be validated in a way that will establish auditable documented evidence that the computer system does what it is expected to do. As applicable, this needs to be carried out in conjunction with plant equipment to provide a high degree of assurance that a specific process will consistently produce a product meeting its predetermined specifications and quality attributes. The methodology to achieve this is based on a recognized life-cycle mode.

### **III. VALIDATION LIFE CYCLE**

Providing documented evidence to achieve and maintain the validated status and uphold GMP compliance requires a systematic approach and rigorous controls throughout all phases of the computer system validation life cycle. Formal testing at key stages in the life cycle will provide records to demonstrate that predefined requirements have been met and that the computer system is fully documented.

#### **A. Validation Process**

The validation of a computer system involves four fundamental tasks.

- Defining and adhering to a validation plan to control the application and system operation, including GMP risk and validation rationale
- Documenting the validation life-cycle steps to provide evidence of system accuracy, reliability, repeatability, and data integrity

Conducting and reporting the qualification testing required to achieve validation status

Undertaking periodic reviews throughout the operational life of the system to demonstrate that validation status is maintained

Other key considerations include the following:

Traceability and accountability of information to be maintained throughout validation life-cycle documents (particularly important in relating qualification tests to defined requirements). The mechanism (e.g., matrix) for establishing and maintaining requirements traceability should document where a user-specified requirement is met by more than one system function or covered by multiple tests

All qualification activities must be performed in accordance with predefined protocols/test procedures that must generate sufficient approved documentation to meet the stated acceptance criteria.

Provision of an incident log to record any test deviations during qualification and any system discrepancies, errors, or failures during operational use, and to manage the resolution of such issues

## **B. Support Procedures**

To control activities associated with the validation program the following “cornerstone” procedures need to be in place and in use:

GMP compliance and validation training—to an appropriate level commensurate with the individual’s job function

Inventory management—to ensure all computer systems are assessed and designated as GMP or non-GMP systems

Document management and control—to ensure the availability of current approved documentation and an audit trail of all records related to the validation program

Configuration management—to ensure system software and hardware configuration and versions are controlled by authorized personnel

Change control—to ensure any change to the system—or to other equipment that may affect system use—is properly assessed, documented, and progressed with regard to GMP compliance and system validation

It is also recognized that satisfactory implementation, operation, and maintenance of a computer system in the manufacturing operating environment is dependent on the following:

Quality management system—to control and document all aspects of the pharmaceutical GMP environment, including provision of a comprehensive set of SOPs to provide written and approved procedures that enable activities to be conducted and reported in a consistent manner



Good engineering practice—to establish engineering methods and standards that must be applied throughout the system life cycle to deliver appropriate, cost-effective solutions that underpin the validation program

### **C. Validation Life Cycle**

The established methodology for computer system validation enables identification and control of each life-cycle phase and its associated document deliverables. It is also recognized that throughout the validation life cycle there is a level of dependency on the methods, services, and resources of the computer system supplier.

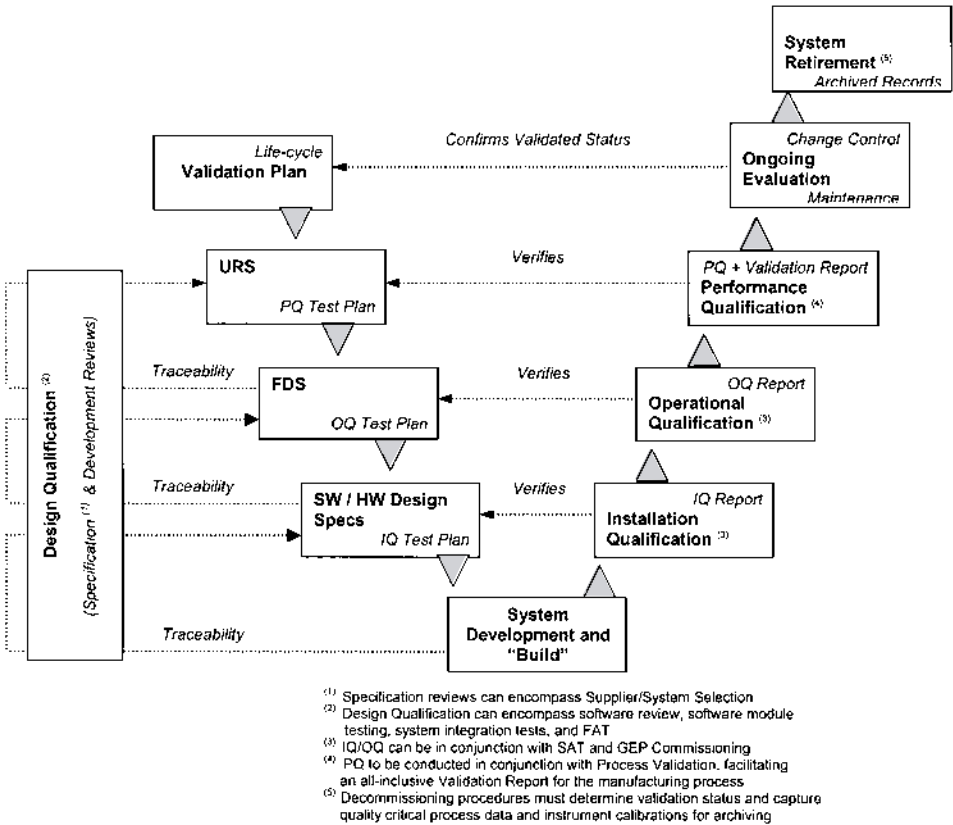
The V model in [Figure 2](#) illustrates the key life-cycle activities for prospective validation, ranging from validation planning to system retirement. It is a recognized methodology for computer system applications and illustrates the links between system planning, requirements and design specifications, and the corresponding reviews and qualifications. It includes the supplier design, development and testing of software modules, and the integration and testing of the combined software and hardware [10]. When successfully executed, each task on the life cycle will result in documented evidence, including a formal report, to support the validation program and ensure a controlled step to the next phase. Formal qualifications must be conducted for system design, installation, operation, and performance. The relationship to the manufacturing process is introduced through the link with PQ to the process validation report. Ongoing evaluation of the system provides confirmation of the validation status of the system throughout its operational life in the GMP environment. Formal decommissioning will ensure accurate data are archived to support released product.

The validation life-cycle phases align closely with the project stages for new computer system applications. With this in mind, it is recognized that a significant proportion of the documentation required for validation may be generated by a well-controlled and -documented project.

The process for implementation and prospective validation of computer systems outlined in [Figure 3](#) depicts the system application activities within each life-cycle phase and identifies key issues and considerations for each step. The process includes for evaluation of both the computer system product and the system supplier's working methods. The same life-cycle approach may be applied to validate the associated control and monitoring instrumentation [9].

### **D. Existing System Validation**

For retrospective validation, emphasis is put on the assembly of appropriate historical records for system definition, controls, and testing. Existing systems that are not well documented and do not demonstrate change control and/or do



**Figure 2** Framework for system validation.

not have approved test records cannot be considered as candidates for retrospective validation as defined by the regulatory authorities.

Consequently, for a system that is in operational use and does not meet the criteria for retrospective validation, the approach should be to establish documented evidence that the system does what it purports to do. To do this, an initial assessment is required to determine the extent of documented records that exist. Existing documents should be collected, formally reviewed, and kept in a system “history file” for reference and to establish the baseline for the validation exercise. From the document gap analysis the level of redocumenting and retesting that is necessary can be identified and planned.

## LIFE CYCLE ISSUES

### Planning

- Key planning documents, control procedures and training in -place
- System boundaries defined
- Decision to validate and rationale

### Definition

- PQ Protocol test criteria derived from and traceable to Requirement Specification
- The Requirement Specification should be formally reviewed and approved. In particular, the requirements for quality-related critical parameters, data and system functions should be verified.

### Supplier Selection

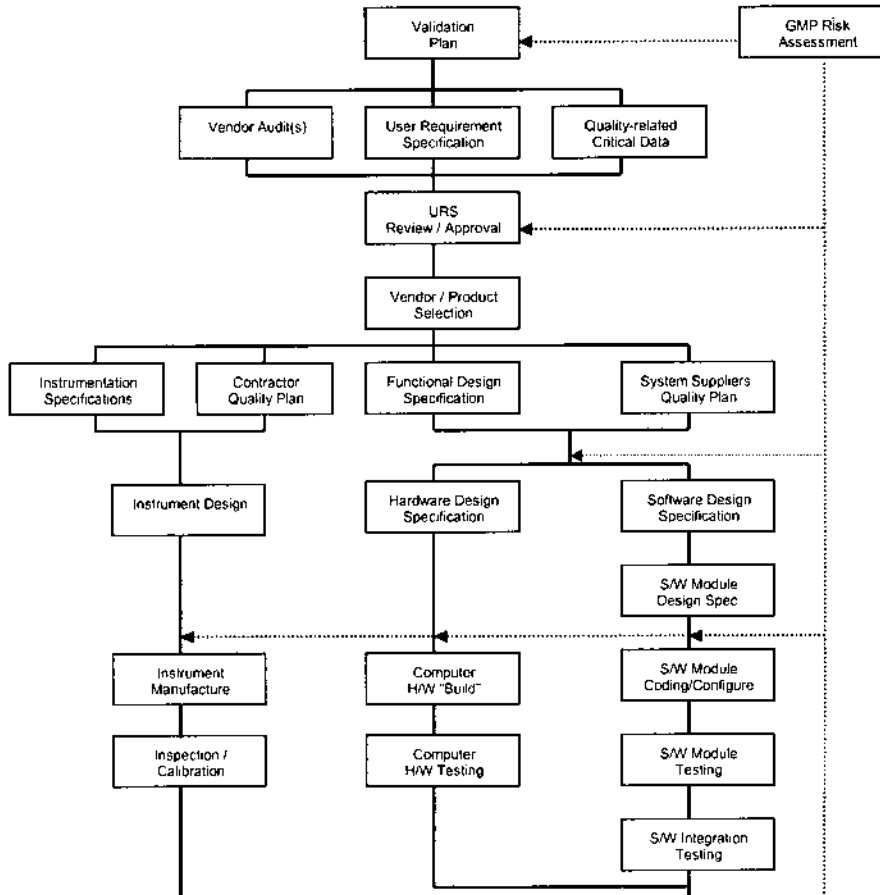
- Supplier selection criteria and audit should cover working methods, system functionality, and GMP knowledge

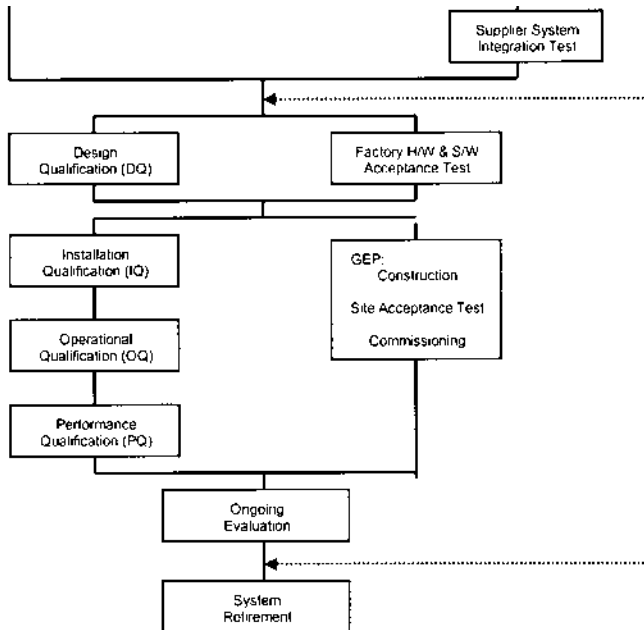
### Design / Development & "Build"

- OQ Protocol test criteria derived from and traceable to Functional Specification
- IQ Protocol verification/test criteria derived from and traceable to Design Specifications
- Conduct Software Review\* to check the code or configuration is to specification, programming standards and provides maintainable software
- System design and development testing under Supplier's Software Quality Assurance Program
- Review against Quality & Project Plan

### Design Qualification (Review)

- DQ ensures system development activities are undertaken in a controlled manner, with reviews of system specifications, development procedures and testing documentation in support of the validation programme





- For more complex systems the design qualification can be accomplished by reviewing key activities throughout system development
- Pre-delivery (FAT) and post-delivery (SAT) acceptance tests to align with the Qualification test procedures as far as possible.

#### Qualification & Commissioning

- Qualification testing for system elements and functions that *directly* impact product / process quality and associated data
- Good Engineering Practice (GEP) and documentation for commissioning of system elements and functions that *do not* directly impact product / process quality
- Tests to be traceable to requirements
- IQ/OQ can be in conjunction with SAT
- OQ/PQ testing to include SOP's
- Each Qualification phase to be formally reported
- A Validation Report and Validation File are the main deliverable

#### On-going Evaluation

- Periodic Review(s)
- Internal Audit Report(s)
- Critical Data Records
- Software Records
- Life-cycle Documents Update
- Maintenance Procedures
- Calibration Records
- Configuration Control Records
- Change Control Records
- Risk Assessment Records
- Disaster Recovery and Contingency Plan
- Re-validation
- De-commissioning Plan
- Document Control

**Figure 3** Computer system development and validation process.

Existing system applications will need to be evaluated and applicable GMP issues and risks identified. Whether it be legacy systems, systems to be revalidated, or systems yet to be validated, the critical parameters, data, and functions that directly impact GMP should be clearly identified and formally documented. Each system should be assessed under a formal procedure to determine compliance with the regulations for electronic records and electronic signatures. Any resulting action plan should include system prioritization and implementation timings.

The methodology for validating existing computer systems will need to adopt life-cycle activities in order to facilitate the process of generating acceptable documented evidence (see Fig. 4). When coupled with an appropriate level of extended system performance monitoring and analysis during system operational use and maintenance, this can provide an effective method for validating existing systems.

For new or existing computer system applications, adherence to a life-cycle approach for validation will provide:

- A framework for addressing the validation plan

- Points at which the validation program can be controlled and challenged

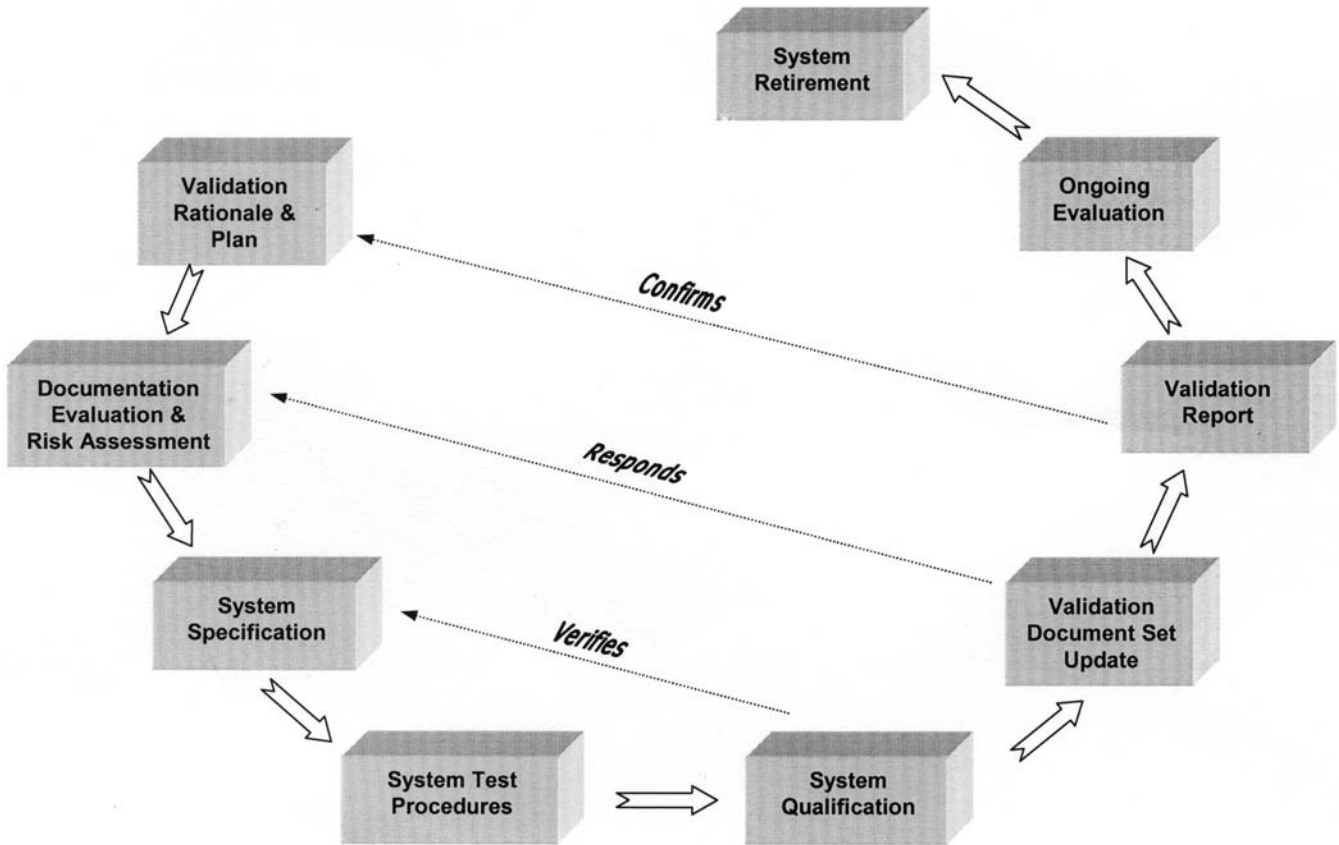
- Auditable documented records of system application and operational use

## **IV. PLANNING**

The pharmaceutical manufacturer must establish effective policies and plans for regulatory compliance and validation to enable individuals to clearly understand the company commitment and requirements. Computer validation planning should ensure an appropriate training program, preparation of validation guidelines and procedures, system GMP compliance risk and criticality assessment, a documented validation strategy and rationale, clearly defined quality-related critical parameters and data for the manufacturing process.

### **A. Training**

The pharmaceutical manufacturer must ensure that personnel are trained to an appropriate level in GMP and validation planning and requirements to enable them to adequately perform their function. This applies to any resource used in connection with GMP compliance and validation life-cycle activities and documentation. A training program should be in place and individual training records maintained. The records and suitability of external resources used by suppliers or contractors should also be examined.



**Figure 4** A validation cycle for existing systems.

## **B. Validation Organization**

An organizational structure should be established to facilitate the qualification of computer systems operating in the GMP environment. The organization should be representative of the departments involved, and would typically include quality management, owner/user department, information technology, and engineering.

## **C. Validation Guidelines and Procedures**

The regulatory authorities require the pharmaceutical manufacturer to maintain guidelines and procedures for all activities that could impact the quality, safety, identity, and purity of a pharmaceutical product. This includes procedures for implementing and supporting the validation life cycle and for process operation.

The pharmaceutical manufacturer will need to prepare written procedures that clearly establish which activities need to be documented, what information the documents will contain, how critical information will be verified, who is responsible for generating the documentation, and what review and approvals are required for each document. Each procedure must give detailed instruction for executing specific tasks or assignments, and should be written in accordance with the pharmaceutical manufacturer's procedure for writing and approving standard procedures and guidelines. For each document the meaning and significance of each signatory must be defined.

Standard operating procedures will be required as written instruction to operating personnel on how to operate the manufacturing process. These will cover operation in conjunction with the computer system and also any tasks that are independent of the computer system. Where there is a requirement for quality-critical data to be manually entered on the computer system, there should be an additional check on the accuracy of the entry. If the computer system is not designed to carry out and record this check, then the relevant SOP must include this check by a second operative.

Key validation and system procedures include the following:

- Preparation of standard procedures
- Document review
- Validation glossary
- Critical parameter assessment
- GMP criticality and risk analysis
- Process validation methodology
- Computerized system validation
- Preparation of validation plans
- Preparation of project and quality plans
- Manufacturing data specification

- URS preparation
- Supplier audit and evaluation
- Qualification protocol preparation
- Qualification review and reporting
- System access security
- Backup, archiving, and retrieval
- System operation and management
- Contingency/recovery planning
- System maintenance
- Calibration
- Periodic review and reporting
- Decommissioning

Incorporating these procedures and the resulting documents into the quality management system will afford a single point of control and archive for all validation procedures.

#### **D. GMP Risk and Criticality Assessment**

Accepting that adherence to the validation life cycle for computer system applications is in itself a method for minimizing risk, the use of formal GMP risk assessments on new and existing applications enables the risk of noncompliance with regulatory requirements to be monitored and controlled throughout the life cycle. Risk priorities are likely to change throughout the validation life cycle, and consideration should be given during validation planning to undertaking/ updating risk assessments at key points throughout the life cycle as application and system detail becomes available.

The assessment should focus on identifying risks to the GMP environment and evaluating the risk likelihood and the severity of impact on the manufacturing process. This will allow risk criticality to be categorized, and together with an evaluation of the probability of detection will enable definition of the action(s) considered necessary to mitigate and monitor each risk. The GMP risk and criticality assessment will assist in identifying the systems and functionality that require validation effort, and will also highlight areas of concern that may attract the attention of the regulatory inspectors. Assessment records complete with the respective system validation rationale should be kept in the validation file.

The initial assessment should be undertaken early in the planning phase and include definition of system boundaries in order to determine and document what systems are to be in the validation program and why. A sitewide inventory should assign each computer system a unique number, descriptive title, and location reference. The main software and hardware components of each system



should be recorded and reference made to the source of quality-related process parameter information.

Each computer system must be evaluated with respect to the functions it performs and the impact on the GMP regulatory environment, thus new systems that need to be validated are identified and existing GMP systems can be confirmed as candidates for a validation status check.

The next risk assessment should be undertaken just prior to issuing the URS, when the process and the user requirements for the system are defined, enabling the affect of system failure, malfunction, or misuse on product quality attributes and the safe operation of the system to be evaluated. This assessment can be reported as part of the URS review and should identify system requirements that need to be reconsidered.

Further risk assessment in the design phase will allow the detailed operation of the computer system as described in the supplier design specifications to be addressed, and enables criticality ratings to be reviewed against the detailed functions of the system and the SOPs. The assessment will provide documented records to support any update to the risk appraisal.

Such analysis can be complimented during definition and design by consideration and identification of safety, health, and environmental matters and application hazard and operability studies generally undertaken as part of GEP.

System GMP risk assessment reviews can be addressed in the qualification summary reports and the validation report, and updated as part of the periodic review of the system validation status.

## **E. Software and Hardware Categories**

Software and hardware types can influence the system validation rationale, and a strategy for the software and hardware types that may be used should be addressed during validation planning.

The type of software used in a GMP manufacturing computer system can be categorized to provide an indicator of the validation effort required for the computer system. This should be addressed in validation planning, and can be examined and recorded during the supplier audit. Software categories should also be reviewed at the DQ stage, before finalizing the levels and priorities of qualification testing.

It should be noted that complex systems often have layers of software, and one system could exhibit one or more of the software categories identified below:

*Operating system* software—document version and data communication protocols, and establish extent of use.

*Standard firmware* (non-user-programmable)—document version, document user configuration and parameters, calibrate, verify operation

*Standard off-the-shelf* software packages—document version, verify operation

*Configurable* software packages—validation life cycle with qualification of the hardware and application software

*Custom-built* software and firmware—validation life cycle with qualification of the hardware and all custom software

The hardware strategy should consider the preferred use of standard hardware components and the potential need for custom-made hardware. The category of hardware components required to meet user and design requirements will provide a guide to the level of hardware specification, design documentation, and development and testing records and will influence qualification activities.

## **F. Quality-Related Critical Parameters**

A fundamental objective of a computer system applied to automate a pharmaceutical GMP operation is to ensure the quality attributes of the drug product are upheld throughout the manufacturing process. It is therefore important that quality-critical parameters are determined and approved early in the validation life cycle. The exercise should be undertaken to a written procedure with base information from the master product/production record file examined and quality-critical parameter values and limits documented and approved for the process and its operation. In addition, the process and instrument diagrams (P&IDs) should be reviewed to confirm the measurement and control components that have a direct impact on the quality-critical parameters and data. This exercise should be carried out by an assessment team made up of user representatives with detailed knowledge of both the computer system application and process, and with responsibility for product quality, system operational use, maintenance, and project implementation. This exercise may be conducted as part of an initial hazard and operability study (HAZOP) and needs to confirm the quality-related critical parameters for use in (or referenced by) the computer control system URS.

The parameters should be reviewed to determine their function (e.g., GMP, safety, environmental, or process control). Applicability of any of the following conditions to a parameter (or data or function) will provide an indication of its GMP impact:

The parameter is used to demonstrate compliance with the process.

The normal operation or control of the parameter has a direct impact on product quality attributes.

Failure or alarm of the parameter will have a direct impact on product quality attributes.

The parameter is recorded as part of the batch record, lot release record, or any other GMP regulatory documentation.

The parameter controls critical process equipment or elements that may impact product quality attributes independent of the computer system.

The parameter is used to provide or maintain a critical operation of the computer system.

As applicable, quality-related critical data should be identified in the loop/instrument schedule and system input/output (I/O) listings.

It is opportune at this point to document the GMP electronic raw data that need to be collected by or through the computer system. This will be used to support the validation rationale and influence the extent of qualification testing. It will also identify candidate data for electronic records and electronic signature compliance and help distinguish between electronic raw data and transient electronic data.

Approved critical parameters and data are not open to interpretation at any time throughout the system validation life cycle. This is particularly important where design and development activities are not directly controlled by the pharmaceutical manufacturer.

## **G. Validation Master Plan**

As with all validation life-cycle documents, a validation plan is a formal document produced by the pharmaceutical manufacturer. The plan should require that all validation documentation is under a strict document control procedure, with issue and revision of documents controlled by means of an approval table, identifying the name, signature, date, and level of authority of the signatory.

A validation plan should describe the purpose and level of the plan and must be consistent with established policies and the GMP risk and criticality analysis. The document must be approved and state the period after which the plan is to be reviewed.

Computer systems that are identified as requiring validation must be included in the site validation master plan. A validation master plan is typically used as a high-level plan for the site or processes and systems that make up the facility GMP operations. The plan should outline the scope of the validation program, controls to be adopted, and how activities are to be conducted, documented, reviewed, approved, and reported. Target completion dates should be included for validation work in each area.

It should address and identify procedures for:

- Validation strategy (including reference to the respective regulations)

- Structure, reference/naming conventions

- Location of validation documentation

- Description of the facility, products, operations, process equipment

- Computer system register
- Validation evaluation and rationale
- Validation program priorities
- Justification for nonvalidated systems
- Validation organization/responsibilities
- Validation training
- Ongoing evaluation: periodic review intervals
- Use of project validation plans
- Support programs and procedures
- Reference documents and definitions

The plan should be reviewed annually (as a minimum) to ensure and record that it is current and that progress is being made against the plan.

## **H. Project Validation Plan**

The project validation plan is for individual projects (including equipment) or systems and is derived from the validation master plan. The project validation plan should be closely linked to the overall project and quality plan.

The validation plan should put forward a reasoned, logical case that completion of the defined activities will be sufficient to deliver the documented evidence that will provide a high degree of assurance that a computer system will consistently meet its predetermined specifications.

A project- or system-specific validation plan should address the following in sufficient detail to form the basis for reporting the validation program:

- Description of process/environment
- Quality-related critical parameters
- Purpose and objectives of the system
- Major benefits of the system
- Special requirements
- Specific training needs
- System operating strategy
- Related GMP compliance/regulations
- Physical and logical boundaries
- System GMP risk assessment
- System validation rationale
- Life-cycle documentation
- Assumptions and prerequisites
- Limitations and exclusions
- Quality-related critical parameters/data
- Standard operating procedures
- System requirement specification
- Supplier and system history

- Vendor evaluations and audits
- System design, development, build
- Software review
- Qualifications (DQ, IQ, OQ, and PQ)
- Qualification and validation reports
- Ongoing evaluation
- Problem reporting/resolution
- Operational plans
- Validation file
- Internal audits
- Support programs/procedures
- Reference documents
- Authorities/responsibilities
- Resource plans and target end dates

The project validation plan is a live document that should be reviewed against each life-cycle step and any other validation milestones (as a minimum). Any changes to the plan should be identified on a revision history section within the document. The plan should be retained in the validation file and should be easily accessible.

For each system validation project the validation team must be identified and would typically consist of designated personnel (normally identified by job function at this stage) that will be responsible for the provision, review, and approval of all validation documents and implementation of the qualification testing.

As applicable, the project engineering contractor and the system supplier/integrator can expect to participate on the project validation team at the appropriate time. The purchasing/contracts groups may also be involved and play a key role in administering contractual validation activities and documentation.

In the case of a computer system applied to a live manufacturing process and integral with plant equipment and the process itself, the project validation plan should specify the relationship of the computer system qualification activities and documentation with that of the corresponding plant equipment qualification and process validation. Indeed, the qualification activities and documentation of these elements of a computerized operation are sometimes combined.

Execution of the project validation plan will provide control and full documentation of the validation.

## **I. Project and Quality Planning**

In the majority of cases, the application of a computer system to pharmaceutical manufacturing is part of a capital investment involving other items of production plant equipment and a wide range of contracted design, installation, and commissioning activities carried out by appropriate engineering disciplines.

The overall project itself requires formally structured planning and control in addition to the validation plans for the computerized operation. To provide this, a project and quality plan from the pharmaceutical manufacturer (or its nominated main contractor) is normally developed as a separate and complimentary document and needs to overview all activities, resources, standards, and procedures required for the project. The plan should define project-execution procedures, quality management procedures, engineering standards, project program, and project organization (with authorities and reporting responsibilities), and reference the project validation plan. There are instances in which the project and quality plan and the project validation plan can be combined into one document.

## **J. Supplier Project and Quality Plan**

As part of the supply contract each supplier or subcontractor needs to provide a corresponding project and quality plan to identify and outline the procedures, standards, organization, and resources to be used to align with the requirements of the pharmaceutical manufacturer's project. The contractors and suppliers involved with GMP work should reference the project validation plan and identify the specific requirements that are to be addressed to ensure the appropriate level of documentation in support of the pharmaceutical manufacturer's validation program.

Project and quality planning by each company is important for multigroup projects, as it enables all those involved in the project—pharmaceutical manufacturer, vendor, or third party—to access a formal definition of project standards, schedule, organization, and contracted responsibilities and monitor interaction at all levels. If elements of the contracted work and supply are to be subcontracted the plan must detail how this work is to be controlled and reported. The supplier project and quality plan must be a contractual document agreed upon by the purchaser and supplier and needs to ensure that:

The pharmaceutical manufacturer's quality management system requirements are met at all stages of the project.

The finished product and documentation will meet quality requirements.

Appropriate resource is made available.

Project time scales and budgets will be met.

Measures or criteria for assessing the attainment of quality objectives should be defined as far as possible, together with an overview of the methods to be used for meeting these objectives.

To support the validation program the computer system supplier's plan should identify which supplier procedures are to be followed for:

- Document standards and controls
- GMP/validation training
- System and data security
- Development methodology
- Software quality assurance
- Design specifications
- Software development
- Software testing
- Hardware testing
- Software tools
- Configuration management
- Change control
- Subcontractor control
- Purchasing
- Information requests/project holds
- Deviation reporting
- Corrective action
- Audits (internal and external)
- Activity schedule
- Allocated resource

Both supplier and customer signatures on the activity schedule can provide a record, for control of the design and development phase of the validation life cycle in support of DQ. The activity schedule can also be used to identify tasks that require input from the pharmaceutical manufacturer.

Task verification should be to the supplier's standard specifications or procedures.

The supplier needs to ensure that:

The phase objectives are defined and documented.

Applicable regulatory requirements are identified and documented.

Risks associated with the phase are analyzed and documented.

All phase inputs are defined and documented.

All phase outputs meet acceptance criteria for forwarding to the subsequent phase.

Critical characteristics are identified and documented.

Activities conform to the appropriate development practices and conventions.

In summary, the planning phase of the validation life cycle encompasses all the up-front preparation activities and documentation, including:

- Validation policy and plans

- GMP/validation training

- Validation procedures

- GMP criticality and risk assessment
- Validation rationales
- Quality-related critical parameters and data
- Project and quality plans

It is imperative that these are in place to support the validation life-cycle activities that follow.

## **V. REQUIREMENTS DEFINITION**

### **A. User Requirement Specification**

The success of a validation program depends initially on the provision and understanding of a formal written definition of the system requirements. The purpose of this URS is to:

- Provide sufficient detail to the supplier to produce a cost, resource, and time estimate to engineer and document the computer system within a validation life cycle
- Provide information for the system supplier's functional design specification (FDS)
- Provide an unambiguous and commonly understood operational and interface listing of functional and system requirements, which can be tested during PQ
- Identify all manufacturing design data, including quality-related critical parameters and data for system design and testing
- Identify the project documentation (and task responsibilities) to support the validation program

It should be recognized that the URS is the base document for developing and testing the computer system and needs to provide clearly defined and measurable requirements. Authorities and responsibilities for provision of information for the URS must be stated in the project validation plan.

The computer system URS needs to describe the levels of functionality and operability required from the computer system, its application, and the location with regard to the process. Definition of approved and accurate manufacturing and process data is a key objective of the URS and is essential in order for the computer system supplier or integrator to fully understand and develop the computer application and to engineer the field instrumentation and electrical controls. This must include the quality-related critical parameters that are fundamental in determining and ensuring the satisfactory quality of a drug product. Parameters, data, and functions that are necessary to uphold GMP must always be considered as firm requirements and candidates for validation.



It may not be possible or necessary to define all engineering parameters and data on issue of the URS. In such cases the URS should document when the information will be available and provide anticipated ranges for preliminary costing and design purposes. Any such interim action must be strictly controlled and reviewed before detailed design commences.

Quality-related critical parameters, data, and functions are essential for specification and contract considerations, system design and development, qualification testing of the computer system, and PQ for the validation of the process. GMP-related system requirements need to be traceable throughout the specification, design, development, testing, and operation of a system. This can readily be achieved by having a “traceability matrix” that will identify corresponding sections and data in the key life-cycle documents.

For the process measurement and control instrumentation the loop schedule enables allocation of a unique identifier (tag number) to each instrument used in the operation of the plant. This will allow application details to be added to the schedule (e.g., range, accuracy, set-point tolerance, signal type, description, location and any other information thought necessary to provide a clear understanding of the requirements for each instrument).

It should be noted that not all parameters that are critical to the manufacturing process are critical with regard to product quality; some parameters may be designated critical for process performance, safety, health, or environmental reasons. Because of the nature and importance of these other critical parameters, it is usual for pharmaceutical manufacturers to consider them under the validation program.

For purposes of documenting criticality of all instruments and loops the following categories may be used:

*Product critical instrument*—where failure may have a direct effect on product quality (normally aligning with the defined quality-related critical parameters)

*Process/system critical instrument*—where failure may have a direct effect on process or system performance without affecting final product quality or safety.

*Safety/environmental critical instrument*—where failure may have direct effect on safety/environment

*Noncritical instrument*—where failure is determined to have no effect on product quality, process/system performance, safety, or the environment.

(The criticality designated to each instrument will form the basis for the calibration rationale and calibration frequency for the system instrumentation and regulating devices. For quality-related critical parameters the range and limits must be accommodated by the instrument calibration accuracy and failure limits.)

It must be made clear that the GMP quality-critical parameters and data are not open to interpretation and must be controlled throughout all life-cycle activities and clearly identified throughout the validation documentation. This is particularly important for parameters and data that need to be controlled by restricted access during the design and development phases and also during operation of the computer system.

Another key objective of the URS is to identify the document deliverables to support the validation program and the responsibilities for provision and management of this documentation during the project.

## **B. Structure and Content of the User Equipment Specification**

The URS can contain a large number of requirements and should therefore be structured in a way that will permit easy access to information. The requirement specification must be formally reviewed and approved by the pharmaceutical manufacturer. A number of general guidelines apply to this specification (and all validation life-cycle documents).

Requirements should be defined precisely; vague statements, ambiguity, and jargon should therefore be avoided. The use of diagrams is often useful. The scope for readers to make assumptions or misinterpret should be minimized.

Each requirement statement should have a unique reference.

Requirement statements should not be duplicated.

Requirement statements should be expressed in terms of functionality and not in terms of design solutions or ways of implementing the functionality.

Each requirement statement should be testable, as PQ test procedures are to be derived from the user requirements.

Where applicable, mandatory requirements should be distinguished from desirable features.

Considering the availability and content of the manufacturing design data and the potential document revisions and change control for large or complex applications, it is sometimes advantageous to compile and issue the operation-specific manufacturing design data as a separate specification document appended to or referenced by the URS.

Whatever the format, the URS for a GMP computer control system application will typically address the following:

- Scope of system supply
- Project objectives
- Regulatory requirements

- Process overview
- System boundaries
- Operational considerations
- Manufacturing design data
- Instrument application data
- Data records
- System functions
- System software
- System hardware and peripherals
- System interfaces
- Environmental conditions
- Access security
- Diagnostics
- System availability
- Safety
- Test and calibration
- Quality procedures
- Software development life cycle
- Documentation requirements
- Training
- O & M manuals
- Engineering/installation standards
- Ongoing support
- Warranty
- Delivery/commercial requirements

Newly sanctioned systems will require compliance with regulations for GMP electronic records and electronic signatures, and definition of the functionality required will need to be included.

It is recommended that wherever possible the structure of the URS be used as the basis for the presentation format of the FDS and hardware and software design specifications; this helps ensure design decisions are auditable back to the source requirement. Traceability should also be carried forward to the qualification test procedures, where it can link each test and qualification acceptance criterion directly to a specific requirement.

Using a “cross-reference matrix” for traceability of parameters, data, and functions throughout the life-cycle documents provides a valuable control and revision mechanism, and will assist document review and change control by providing a document audit trail for the validation program.

It is advisable to start compiling the matrix on approval of the URS. The exercise can also be used as a check on the key requirements itemized during the initial GMP risk assessment and to provide focus for developing initial quali-

fication test plans. The status of the traceability matrix should be recorded as part of each qualification summary report and kept in the validation file.

The URS is a “live” document (or set of documents) and may require revising at various points in the project. It should be retained in the validation file and should be easily accessible. Any revisions must be carried out under a strict change control procedure.

Once reviewed and approved internally, the URS is issued to prospective suppliers as part of the tender document set so that detailed quotations for the system application can be obtained. The contractual status of the URS and its importance to the validation program should be made clear to the supplier.

In summary, producing a computer system requirements specification in the form of the URS provides the following key benefits for the validation program:

- Clarifies technical, quality, and documentation requirements to the vendor(s)
- Enables the pharmaceutical manufacturer to assess the technical, regulatory, and commercial compliance (or otherwise) of submitted bids against a formal specification
- Ensures the basis of a structured approach to the presentation of information that can be carried forward into the specifications produced during the system development phase
- Provides a basis for testing and test acceptance criteria

It is recognized that the URS may be superseded by the FDS as the definitive specification for system design. The URS, however, remains the technical and operations statement of user requirements and must be maintained under change control as an up-to-date document throughout the life of the system. The URS also remains the base document against which PQ is verified, and once the URS is approved a PQ test plan can be generated.

## **VI. SUPPLIER SELECTION**

Manufacturing process control and automation systems can be divided into two main categories [3].

*Stand-alone systems.* Multiloop controller(s) or programmable logic controllers (PLC) typically used to control part of a process, and larger supervisory control and data acquisition (SCADA) systems/distributed control systems (DCS) used to control the process or service as a whole (e.g., bulk primary production plant, building management systems). These self-contained systems are a component of an automated manu-

facturing process application and are usually developed and delivered as free-standing computer systems by the system supplier separate to the process equipment for connection to the associated “field” instrumentation/regulating devices and, as applicable, to each other.

*Embedded systems.* Smaller microprocessor-based systems, such as a PLC or PC, with the sole purpose of controlling and/or monitoring particular manufacturing equipment. They are usually developed and delivered by the equipment supplier as an integral component of the process equipment or package plant, (e.g., filling machine, packaging machine).

For both embedded and stand-alone systems the supplier must adopt a life-cycle approach to system design and development to provide a level of documentation that can be used to support the qualification phases and requirements traceability from specification through to testing. This will also to support effective validation at minimum cost.

## **A. Selection Criteria**

Pharmaceutical manufacturers expect the computer system supplier or integrator to understand the needs and constraints of the GMP environment. The fundamental requirement is for the system supplier to ensure that no assumptions are made with respect to the accuracy and dependability of the system. For this, the following need to be addressed:

- Design for consistently accurate and reliable operation

- Reduce exposure to loss of expertise and knowledge by documenting system application, design, development testing, problem resolution, and enhancements

- Minimize risk to system design, development, operation, and maintenance by conducting and recording these activities to approved written procedures

Selection of the computer system and system supplier involves evaluation of a supplier’s development and project working methods, and also initial evaluation of the basic system software and hardware functionality with regard to GMP application.

A supplier will need to demonstrate structured working methods with full and auditable system documentation. The chosen supplier will also be expected to provide qualified and trained resource with appropriate knowledge of validation methodology and experience in providing solutions for GMP-regulated applications.

Suppliers with system development and project execution procedures in line with validation life-cycle requirements are well placed to deliver the appropriate level of validation support documentation. The existence of supplier test

procedures that cover system acceptance testing and support qualification testing will streamline the validation. Suppliers that can analyze how their system functionality aligns with GMP are in a good position to directly assist with key activities within the validation program (e.g., GMP risk and criticality assessment and maintenance).

It is recognized that an in-place and in-use quality management system certified to (or in line with) the ISO series of quality standards is key to supporting system validation goals. In particular, certification to the TickIT Software Quality Management System [11], with its emphasis on software development to ISO guidelines, can be a distinct advantage. The supplier will need to demonstrate a documented process for planning, implementing, controlling, tracking, reviewing, and reporting all project activities in a structured and consistent manner.

Evaluation and selection criteria for the system software will depend upon the type of software being considered. For standard software, such as the operating system or a canned or commercial off-the-shelf configurable package, a history of satisfactory use is a major consideration. The number of installations and the length of time the current version of the program has been in use, in conjunction with a review of relevant software problem reports and the history of changes to the program, may provide adequate evidence that a program is structurally sound.

If software is to be developed or custom-configured for the application, the supplier's software quality assurance program would be a key factor in indicating the ability of the supplier to provide an acceptable system. For a newly developed system consideration should be given to examining the design, development, and testing methods and records of the operating system software to the same level as for application-specific software. The computer system supplier should be able to demonstrate data integrity within the system and associated interfaces and networks, using proven data communication protocols and onboard diagnostics that monitor and record accurate data transfer.

Hardware evaluation tends to be less complex than software evaluation, and unless hardware is being designed and built specifically for the application it will generally comprise standard components with defined performance detail that can be evaluated relative to the functional requirements and operational specifications. This also applies to the measurement and control instrumentation.

The evaluation should also examine the ease of calibration and self-documentation of both the computer system and associated measurement and control instrumentation, along with the availability of replacement parts and service support for the expected lifetime of the system application.

The history of the computer system in similar applications should also be explored to determine evidence of system durability, reliability, repeatability, and accuracy.

## **B. Vendor Evaluation**

Initially potential suppliers can be sent a postal questionnaire that requests information on the company, the services provided, resources, system development expertise and range of experience, customers they have supplied, and maintenance support.

Two main areas should be addressed, and the vendor records may need to be examined during the supplier audit.

The methodology and records for design and development of system source code (operating system level), including version control and management and access availability.

The procedures used to design and develop project-specific application software, including version control and management, the documentation provided, and backup copy availability.

Responses to the questionnaire should be formally reviewed and a report produced that highlights any perceived areas of weakness or points for further investigation. From a formal review of the responses, those suppliers who are considered most suitable can progress to the next stage of evaluation.

## **C. Inquiry and Quotation**

The tendering process is primarily associated with the overall engineering and commercial considerations but is important to the validation program in that it provides the means to:

Clearly define what is required from the computer system supplier

Identify initial and collective interpretation issues that need to be clarified

Capture the initial supplier documentation describing how they intend to meet the user requirements

Introduce into the selection process the supplier evaluation and audit findings regarding GMP and validation requirements for personnel qualifications, working methods, level of documentation, and in-built system functionality

Depending on the contractual approach, the responsibility for the provision, design, and testing of the computer system may be separate from that for the application engineering, provision, design, and testing of measurement and control instrumentation (and associated “field” equipment; e.g., cabinets and cabling).

The tender package documentation needs to provide all the elements necessary to define the project, and typically includes the project validation plan, a detailed scope of work, the URS, the documentation deliverables, and the associated commercial documentation.

The pharmaceutical manufacturer should request all technical information relevant to the tender in a standard form, and the vendor should be asked to detail its solution by referencing specific inquiry document sections, clearly identifying any requirement that cannot be met.

The main tender document submitted by a vendor will be the FDS, and this needs to include traceability to all specified user requirements. Vendors should also be requested to outline a project and quality plan to identify how they would carry out the project.

The quotations are to be formally evaluated by the pharmaceutical manufacturer with the purpose of selecting the proposal that best meets requirements and fully supports the pharmaceutical manufacturer's validation program. Quotation evaluation should involve the user representation necessary to ensure that quality, validation, GMP risk, production, technical, maintenance, commercial, and safety and environmental requirements are properly addressed.

The quotation should be evaluated methodically against the following criteria and each evaluation meeting recorded:

- Capability of a supplier to meet all defined project and support requirements

- Alignment of proposed system FDS with the URS

- System life-cycle development methodology and documentation

- Costs of proposed system

- Delivery dates and program

#### **D. Supplier Audit**

Unless a recent and similarly focused formal audit has already been undertaken, the pharmaceutical manufacturer should conduct a detailed audit at the premises of the potential supplier(s) to examine the in-place methods and records reported by the vendor prequalification and any submitted quotation. Audits may be undertaken before and/or after the quotation stage.

A supplier needs to recognize the importance of this examination in providing a documented record for the pharmaceutical manufacturer's validation program and be prepared to fully support the audit (and any follow-up activities) in a timely manner. Guidance on computer system supplier audit issues is available in the GAMP guide [3] and from the PDA Technical Report 32 [12]. With most system suppliers operating under ISO-certified or similar quality systems, training afforded by appropriate courses on the TickIT Guide [11] will also benefit software audits. At a minimum, the following considerations of a supplier's operation would need to be examined:

- Company finances and stability

- Management commitment

- Organization



- Quality management system
- Professional affiliations
- Confidentiality
- Resource availability/qualifications
- GMP application knowledge
- Training program
- System(s) availability
- System life planning/migration
- System engineering procedures
- Project procedures
- Procurement procedures
- Subcontractor control
- Production procedures
- System “build” security
- Site installation/testing procedures
- Handover and final documentation
- System operating procedures
- Calibration/maintenance procedures
- Maintenance support and equipment
- Document control
- Change control
- Internal audits
- Review and approval process
- Configuration management
- Contingency/recovery procedure

As appropriate, the following quality assurance practices and records applicable to the operating system software, application-specific software, and hardware should be reviewed by the pharmaceutical manufacturer (or its nominated representative):

- Operating system code availability
- Software/hardware specifications
- Software/hardware design practices
- Product design records
- Program coding standards
- System development records
- System test records
- Programming tools
- Control of nonoperational software
- Removal of “dead code”
- Deviation analysis/corrective action
- Virus detection and protection

- Software release
- Master copy and backup
- Version control
- Software replication
- Problem reporting/resolution
- Fault notification to customers

To automate operation of pharmaceutical manufacturing processes, the computer software in many instances becomes the “operating procedure,” and thus the following in-built functionality and performance of the computer system itself should also be examined to ensure alignment with GMP application:

- System controls
- Access security (SW and HW)
- Data integrity (data transfer)
- Electronic record/signature
- Accuracy
- Repeatability
- Self-documentation
- In-built diagnostics

An audit report will serve as the formal record of the audit and its findings, and is a major input into selecting the supplier and determining any necessary corrective action. To complete the quotation review exercise the pharmaceutical manufacturer (or its main contractor) should produce a formal report that summarizes the quotation compliance, the key points of the audit report, and the main benefits of each system. The chosen supplier and reasons for the supplier selection should be clearly stated.

A review of the GMP risk implications should be undertaken at this time and may be included as a section of the report.

## **E. Award of Contract**

Any revisions that have been agreed upon by the pharmaceutical manufacturer and the selected supplier must be included in the tender package documents and quotation. Any revisions to the URS must be implemented under the pharmaceutical manufacturer’s change control procedure.

A formal agreement that references all relevant tender documents and clearly identifies responsibilities and document deliverables should be prepared by the pharmaceutical manufacturer. The purchase order should include the final agreement and identify any associated contractual documentation. A copy of the signed final agreement and purchase order should be retained in the pharmaceutical manufacturer’s validation file, together with evaluation records applicable

to the selection of the chosen supplier. The latter should include the initial list of prospective system suppliers, and the prequalification, audit, and quotation related to the selected supplier.

The computer system supplier's detailed project and quality plan incorporating the procedures for software quality assurance should be one of the first contracted deliverables, if not already submitted as part of the quotation or requested during precontract discussions.

At this point for both the project schedule and the validation program the emphasis is on work activities that are contracted to the supplier(s) for system design and development and aimed at fulfilling the agreed-upon FDS. The majority of this work is normally conducted at the supplier's (or engineering contractor's) premises.

## **VII. DESIGN AND DEVELOPMENT**

The design, development, and "system build" phases need to deliver computer systems and services in a manner that facilitates effective and efficient system validation, operation, maintenance, modification, and upgrade. This applies to both stand-alone and embedded process control computer systems (see Sec. VI).

Design, development, and system build is normally a period of intense activity, in which a supplier will be involved in life-cycle activities and will need to provide a set of auditable design and development documentation to support the validation program. For this, the entire design and development process should be carried out to written and approved procedures, and all design, development, testing, and verification activities should be documented and approved in order to provide a level of computer system documentation that can be used to support the pharmaceutical manufacturer's life-cycle qualification activities.

The supplier's design, development, and system-build activities should be based on a set of top-down design specifications and a corresponding set of development test procedures and records, with all work undertaken to the supplier project and quality plan and in line with the pharmaceutical manufacturer's project validation plan. The documentation for design, development (including development testing), and system build must be progressed through an agreed-upon document control system, with approved documents under strict revision and change control.

### **A. Functional Design Specification**

The overall design intentions for the computer system should be defined in an FDS which is normally written by the supplier and must describe how the intended system will meet the customer's application requirements. Once the FDS

is produced there should be a formal verification that it addresses the functions set out in the URS. (See Sec. V.)

The FDS needs to clearly identify any nonconformance with the URS, giving the reasons for any divergence. Similarly, any system function or software that is an integral part of the system on offer and would exist within the system but not be utilized for the application must be identified, complete with proposals of how the function or software can be made inoperative or protected from misuse. The pharmaceutical manufacturer must examine all such issues for operational and GMP impact and if applicable the URS must be formally updated under change control. If not detected at this stage, omissions and misinterpretations will inevitably mean modification at a later date, with the risk of delays and budgetary overruns.

When the FDS is approved it must be subject to formal change control by the supplier for any subsequent amendments. Change control should also be applied to any dependent documents.

The FDS must include all measurable or determinable parameters that may affect system performance and identify the source of supply of both hardware and software. The FDS needs to address each user requirement, defining the following:

- The system hardware and software architecture
- Data flows and records
- The functions to be performed by the system and all normal operating modes
- The manufacturing data on which the system will operate, and connections to the manufacturing process through the measurement and control instrumentation
- How the integrity of quality-related critical process parameters and data will be maintained throughout design, development, and acceptance testing and within the system in its operational use
- The system interfaces; i.e., the operator interface and interfaces to other systems and equipment
- Testing and diagnostic provisions
- All nonfunctional considerations related to the system use

For each function of the system the following needs to be addressed:

- Objective of the function
- Use of the function
- Interface to other functions
- Performance and limitations of the function in terms of accuracy, resolution, and response time
- Safety and security, including access restrictions, time-outs, data recovery, and loss of services

By defining each function in this manner the framework of the respective test procedure exists as each function has to be tested against these criteria.

To support requirements and critical parameter traceability the FDS should, where possible, adopt the format of the URS. (See Secs. V and VI.) It is important that these primary corresponding specifications are fully understood by both the user and the supplier and are formally reviewed and approved before the supplier prepares the design specifications for hardware, software, and the control and monitoring instrumentation and regulating devices.

In summary, the life-cycle objectives of the FDS are as follows:

To define how the supplier's system will meet the needs of the pharmaceutical manufacturer as detailed in the URS (i.e., the FDS is the physical mapping of the supplier's system onto the URS)

To enable the pharmaceutical manufacturer to examine the feasibility of the manner in which the supplier will meet the requirements stated in the URS

To allow the pharmaceutical manufacturer to understand the extent to which the system as defined meets the requirements of the URS

To ensure a structured approach to the presentation of information that can be referenced to the URS and carried forward into the software and hardware design specifications

To define functional design requirements on which to base the detailed software and hardware design specifications

To provide the base document for OQ testing

The FDS will also form the basis for contractual acceptance testing, both at the supplier's premises (factory acceptance test, FAT) and on delivery to the site (site acceptance test, SAT). With suitably compiled test procedures these "traditional" contractual acceptance tests may be incorporated with the qualification testing required by the validation life cycle.

To address this level of testing the FDS should outline the calibration, testing, and verification needs of the computer system to ensure conformance with the manufacturing design data, and in particular the critical process parameters. For this the FDS needs to consider:

- Review of calculations
- Testing across full operating ranges
- Testing at the range boundaries
- Calibration of connected instruments
- Testing of alarms/interlocks/sequences
- Electronic data records
- Conditions and equipment
- Record of test results

## **B. System Design Specifications**

System design uses a top-down approach with an appropriate level of design specifications to detail how the system hardware and software will be built to meet the application design requirements defined by the FDS.

System design specifications will be used by the supplier as working documents during the design, development, integration, and “build” of the system, and after qualification of the system as support documentation by those responsible for the maintenance and future enhancement of the system.

The system design activities include:

The detailed design and provision of computer system hardware and software to meet the requirements of the FDS

The detailed application engineering and design for measurement and control instrumentation, interconnecting cabling/tubing, and the associated installation, to meet the manufacturing process specifications

Any divergence between the system design specifications and the FDS should be clearly identified by the supplier. The pharmaceutical manufacturer should review any nonconformance with the supplier, and to ensure consistency the outcome should be reflected in controlled changes to the preceding requirement specifications and/or system design specification.

The pharmaceutical manufacturer should consider its role with regard to system design documents in light of the experience available to it. It may not be appropriate to approve system design specifications, but may be appropriate to provide comment on the level of information. It should be noted that some form of diagrammatic representation can improve understanding of system design specifics.

## **C. Hardware Design Specification**

The hardware design specification must describe the hardware that will make up the computer system and the hardware interfaces. The defined hardware should be traceable back to statements in the FDS. Once the hardware design specification is produced and approved it is possible to generate a hardware test specification.

The objectives of the hardware design specification are as follows:

To define the constituent hardware components of the system, how they intercommunicate and what constraints are applied to them

To define any communication to external systems and measurement and control instrumentation, and the associated hardware requirements

To enable the pharmaceutical manufacturer to determine the implementation strategy of the supplier

- To enable the supplier to demonstrate the correctness and completeness of the hardware design with the FDS
- To allow the pharmaceutical manufacturer to understand and compare the hardware design and traceability to the FDS
- To provide input to the hardware test specifications
- To ensure a structured approach to the presentation of information that can be carried forward into the hardware test specification

The structure of the hardware design specification should be such as to facilitate comparison with the FDS.

#### **D. Software Design Specification**

For GMP applications the software development must be based on a fully documented and structured design and formally reviewed to ensure that it is reliable, safe, testable, and maintainable. A modular approach to software design with annotated documentation will provide a better understanding of the system software throughout the relevant life-cycle activities and also during regulatory inspection. Use of standard software should be considered whenever possible.

The software design specification is written by the system supplier and must identify how the supplier intends to provide system software under a software quality assurance plan. The design specification must describe the subsystem software that will make up the computer system software and subsystem interfaces to implement the aims set out in the FDS. Each subsystem should be traceable back to statements in the FDS.

Once the software design specification is produced and approved it is possible to generate a software module integration test specification. It is advantageous to produce these documents in parallel so that software definition and testing correspond.

The software design specification has the following objectives:

- To define the constituent software components of the system, how they intercommunicate and what constraints are applied to them
- To enable the pharmaceutical manufacturer to determine the implementation strategy of the supplier
- To allow the pharmaceutical manufacturer to ensure the correctness and completeness of the software design through traceability to the FDS
- To provide input to the system integration test specification
- To ensure a structured approach to the presentation of information that can be carried forward into the software test specifications
- To ensure a structured approach to the presentation of information that can be carried forward, as applicable, into the software module design specifications produced later in the system design

The structure of the software design specification should be similar to that of the FDS to facilitate checking between the two documents.

## **E. Software Module Design Specification**

A software module design specification shall be produced for each software subsystem identified in the software design specification. The software module design specification must document how module design will be implemented and must contain enough information to enable coding of the modules to proceed.

The software module design specification has the following objectives:

To define the implementation of individual modules—how they communicate within the subsystem software and what constraints are applied to them

To enable the pharmaceutical manufacturer to determine the implementation strategy of the supplier

To allow the pharmaceutical manufacturer to ensure the correctness and completeness of the software implementation through traceability to the software design specification

To provide input to the software module test specifications

To ensure a structured approach to the presentation of information that can be carried forward into the software module test specifications

The structure of the software module design specification should be similar to that of the software design specification to facilitate checking between the two documents. Once the software module design specification is produced and approved it is possible to generate a software module test specification.

## **F. Instrumentation Application Engineering**

The design of control and monitoring instrumentation and regulating devices should be based on an established document management system that enables preparation to be formally approved, implemented, recorded, and audited. Typical contents and document deliverables of an integrated engineering documentation system are as follows:

Drawing register

Loop schedule

Instrument data sheets

Instrument loop schematics

Logic and interlock diagrams

Wiring diagrams



- Pneumatic hookups
- Process connection drawings
- Instrument/electrical interface
- Earthing schedule and drawings
- Cable/tubing routing drawings
- Cable and termination schedules
- Cabinet/rack layout
- Control room layout
- Operator console/station(s)
- Field panel and junction box layouts
- Label schedule
- Instrument installation specification

Application engineering and design for measurement and control instrumentation is an interactive process that is centered on a loop schedule normally generated from an approved set of P&IDs and approved manufacturing process data. Because of the interrelationship between the various types of instrument design documentation and the sharing of design information, many of the documents are produced in parallel.

All manufacturing process data should be approved by the pharmaceutical manufacturer end-user and quality assurance groups and be specified as manufacturing design data, including critical process parameters and data, as part of the URS.

The loop schedule and instrument data sheets [9] are key documents that enable process data to be recorded in a manner that brings together the computer system and the process to be controlled and monitored.

## **G. Loop Schedule**

The loop schedule should list all in-line and associated instrumentation for the process application. For each instrument, a typical loop schedule will be developed to provide the following information:

- Unique tag number
- Service/duty description
- Equipment description/type
- Alarm action
- Interlock action
- Location
- Manufacturer
- Purchase/requisition number
- P&ID reference
- Specification or data sheet number
- Electrical hook-up drawing number

- Pneumatic hook-up drawing number
- Process hookup drawing number
- Control system I/O signal and address

## **H. Instrument Data Specification Sheets**

These are generally standard preformatted documents that provide the technical specification and design data for each instrument on the loop schedule, and are primarily used for purchasing the equipment and the basis for calibration.

Each instrument specification would include instrument, process, and environmental information to enable correct application of each instrument to the manufacturing process. For each instrument and under a unique tag number all the physical, technical, installation, operating conditions, and service requirements are to be documented and must include:

- Range of instrument and manufacturer's accuracy
- Materials of construction, especially of process contact (wetted) parts
- Process connection details (e.g., chemical seals, capillary lengths, flange rating)
- Control characteristics (as applicable)
- Process media reference
- Working range (of the measured process variable)
- Control set points, alarm, and interlock switch points (as applicable)
- Engineering range and signal type/level
- Operating/calibration tolerances
- Fail-safe mode

Each data sheet should also identify the expected support documentation and the number required, for example:

- Factory calibration certificates
- Testing/calibration equipment identification (e.g., traceable to national standards)
- Manufacturers' operation and maintenance manuals
- Approval certificates for EMC/RFI/hazardous areas
- Layout drawings showing overall dimensions
- Electrical schematic wiring and/or pneumatic connection diagrams
- Nonlinear range/calibration charts
- Valve sizing calculations

## **I. Software and Hardware Development**

The development for the computer system is based on the design specifications and once the system design specifications for the application have been agreed upon the computer system development and build can commence.

This phase of the supplier's work will be conducted according to the agreed-upon project and quality plan using the supplier's approved procedures, and will involve:

- Provision of system hardware, software, and associated instrumentation that are part of the contracted supply
- Application software development, including development testing
- System assembly
- Hardwiring of components
- Documentation preparation

## **J. Software Code and Configuration Review**

The development phase needs to accommodate a software code/configuration review process to:

- Provide a high level of confidence that the software code or configuration meets the defined operational and technical requirements of the system design specifications and the URS
- Ensure that the software code or configuration is to a standard that will ensure clear understanding and support maintenance and modification of the software throughout the system validation life cycle

The pharmaceutical manufacturer, or its designated representative, would normally conduct software review(s) prior to the supplier's software development testing in order to reduce the potential of retesting.

For the review(s) to be effective the reviewer must have knowledge of the software techniques and the system application. The review should be carried out in accordance with a written procedure and the findings should be documented. The scope and degree of software examination will need to be decided and justified, with consideration as to whether a single review conducted on completion of the software development or a series of reviews throughout the software development is the most appropriate approach for the software being developed.

A decision not to perform the review (e.g., evidence that code is developed under a quality system and formal reviews have already been conducted and reported) should be documented in the project validation plan, complete with the rationale. It is recognized that under its software quality assurance program the supplier may conduct similar examination of the software using only internal resource. Considering GMP implications, the pharmaceutical manufacturer would normally require that the software designer or programmer does not carry out any software review in isolation.

A variety of methods have been developed to review software (e.g., inspections, walkthrough, and audit). Flow charts graphically representing data flow and software module architecture will clearly aid the review, particularly when verifying design requirements.

The review needs to determine:

- Adherence to specified software standards and practices
- Adequate annotation that identifies the software, clarifies data and variables, and clearly describes operations to be performed
- Adherence to software design specifications for the application
- Possible coding errors
- Presence of any “dead” or “unused” software (with the agreed resulting action)

A software review will typically cover software record availability and content, any previous review findings, support documentation, configuration, and change control records. First, the review should investigate adherence to suitable documented software practices for consistency in approach, complexity control, terminology, readability, maintainability, version control, and change control. Second, key areas of software should be identified with due consideration of the system complexity and size, programming competence, system history, operating environment issues, and GMP criticality. For this key software the reviewer needs to examine the following in relation to the design specifications and the predefined quality-related critical parameters, data, and functions:

- The logic flow of data
- Definition and handling of variables and I/O
- Control algorithms and formulae
- Coded/configured calculations
- Allocation and handling of alarms, events, and messages
- Process sequencing
- Process and safety interlocks
- Content of electronic data records, logs, and reports
- Information transfer
- Error handling
- Interfaces with other systems
- Start-up and failure recovery

The operability of the system must also be examined so that there is confidence that the configuration ensures unused system functionality is deselected and cannot be used.

A report should overview the software review findings and append or reference complete sets of annotated software listings resulting from the review.

Where the supplier withholds software listings an access agreement should be established.

The report should document any corrective action or change that is required to make the software acceptable. Corrective action plans should document responsibilities and the rectification date, and where applicable record the change control reference number. Resolution of any problems should be reported under the DQ.

## **K. Software and Hardware Development Testing**

During system development and build the supplier will normally be responsible for all software and hardware development tests and reports, with the pharmaceutical manufacturer involved as agreed upon under the contract. Development test specifications are to be used to demonstrate that the developed software and hardware provides the functionality and operation as defined in the system design specifications.

In many instances operating system software has already been developed and is offered as a fundamental part of the computer system ready for application software to be developed or configured. In such cases it is prudent to establish the existence of the respective software quality assurance plans and procedures and the design, development, and testing records. Identification and examination of this documentation can be conducted and recorded as part of the supplier audit. (See Sec. VI.)

Development tests must be derived from and traceable to statements in the respective design specification, and hence will be traceable to the FDS and URS. Tests for each requirement should be prepared on completion of each design specification to help ensure all matters are addressed.

Testing of application software should include both structural verification and functional testing. Structural verification of software takes into account the internal mechanism of a system or component, and is to ensure that each program statement is made to execute and perform its intended function. Functional testing focuses on outputs generated in response to selected inputs and execution conditions, and is conducted to evaluate the compliance of a system or component with specified functional requirements and corresponding predicted results. For both forms of testing it is important to have program documentation, such as logic diagrams, descriptions of modules, definitions of all variables, and specifications of all inputs and outputs.

All levels of development testing for the computer system must be fully documented and provide test records in the form of approved test procedures, signed-off test result sheets, and reports. For system parameters, data, and functions that are critical to product quality and GMP compliance it is beneficial that the test procedures align with qualification test requirements, and record

tests and calibrations against predefined expected results and acceptance criteria. This will allow supplier development testing records to be considered for use during the life-cycle qualifications.

Software and hardware testing starts during the development phase with a bottom-up approach, software module, and hardware tests need to verify that the implementation of the design for each software or hardware element is complete and correct. Integration testing in which software elements are combined and tested as a complete application program should where possible be conducted using the actual computer hardware. These tests will include all system interfacing, networking, and field connection requirements, and are part of the supplier's in-house test activities to ensure computer system readiness for acceptance testing.

Development test specifications include the following:

*Software module test specification*—for testing individual software components against the software module specification

*Hardware test specification*—for testing the hardware components against the hardware design specification

*Integration test specification*—for testing the software module integration against the software design specification on suitable hardware.

A development test specification should define:

Software and hardware to be tested

Tests to be performed

Data or inputs to be tested

Test method

Expected results

Acceptance criteria

Test and witness personnel

Test location and environment

Test equipment/software required

Test documentation required

A development test specification needs to be prepared by someone with knowledge of the respective design specification but who has not been involved in its implementation. This is to ensure that the testing is not influenced by knowledge of the development.

Each test procedure and resulting test result sheet(s) should be linked by a unique test reference number and be in a logical order, particularly if a series of tests are required for similar items. This ordering method should be clearly explained.

Each test run should be recorded on a separate test result sheet and signed and dated as a minimum by the tester and a test reviewer. All test information should be recorded on the test result sheet, or as necessary on clearly identified

separate sheets attached to the test sheet. The information collected may then be used for summarizing and reviewing the results of the tests.

A development test result sheet should include the following information at a minimum:

- Name of software or hardware
- Reference number of software or hardware
- Version or model number
- Type of testing being undertaken
- Test equipment/software used
- Test reference number
- Test-run number
- Number of attached sheets
- Data or inputs tested
- Expected result(s)
- Test result(s)
- Comments/observations
- Time taken for test
- Overall test status (pass/fail)

A test is deemed to be successful only if all the acceptance criteria defined in the test procedure have been met. A test review team should be formed that will assess and report on all tests, and any involvement by the pharmaceutical manufacturer should be documented. This team should have final authority on test findings. As required, the test review team should decide where controlled changes are required to specifications and whether or not tests should be rerun. Tests are to be conducted in a logical order, and adverse test results must be resolved before progression to any linked test or the next development phase.

## **L. Software Release**

Supplier software release and replication procedures must ensure that only approved products are available for use by the pharmaceutical manufacturer. It is advisable to have release authority with review groups who are independent of the development team.

Only upon the successful completion of the integration testing and documentation review should product release be authorized. Once an application software program is released, it should be placed under formal configuration/version control, and any revisions must follow the requirements of a change control procedure.

## **M. System Build**

For an embedded system the final assembly of the control system and associated electrical and mechanical components into the manufacturing equipment will

normally precede factory acceptance testing of the automated equipment at the supplier's premises, or may take place in a controlled area of the user's site.

For a stand-alone system the computer system normally undergoes factory acceptance testing at the supplier's premises, and as with associated instrumentation and regulating devices is shipped to the site, inspected, and where applicable is stored and then installed with the manufacturing process/plant equipment.

In both cases, the system build phase is to be performed according to the specifications and assembly drawings of the component manufacturer. Assembled systems using hardware from different sources require verification confirming the compatibility of interconnected hardware components.

## **N. Acceptance Test Specification**

Formal acceptance testing to an agreed-upon specification is to be carried out on the developed software and hardware and for the engineered measurement and control instrumentation. This is intended to prove to the pharmaceutical manufacturer that all components and documentation are available and the system functions as defined in the system specifications. The acceptance test specification should include verifications and tests covering the following:

- All hardware and software documented
- All operational and control functions of the FDS
- All data storage and reporting requisites
- All alarm and error reporting functions
- All measurement and control instrumentation inspected, calibrated, and installed

The acceptance test specification may contain a large number of tests. It should therefore be structured in a way that will permit simple cross-reference to the functions specified in the FDS, and hence the URS.

The supplier will normally apply GEP in covering the two parts of this contractual acceptance test, namely FAT and SAT. However, and if required by the pharmaceutical manufacturer, it should be possible to structure acceptance testing to include the enhanced level of verification, testing, and documentation that are necessary for the in situ qualification under the validation life cycle.

## **O. Factory Acceptance Test**

This is normally the first stage of system acceptance testing and should be witnessed by the pharmaceutical manufacturer prior to agreement for the system to be delivered to the site. The supplier should ensure that the system can pass the predefined tests prior to the witnessed acceptance testing so as to minimize the risk of any retesting. The supplier may be requested to produce records of



any preparatory testing that was not witnessed by the pharmaceutical manufacturer.

The FAT is normally a contractual acceptance test that serves to ensure that within the limitations of testing available at the supplier's premises the system operates satisfactorily, and for any problems identified during testing has the advantage of being directly resourced and resolved in the development environment. Problems (particularly software-related) carried over or detected on site are invariably more difficult and time-consuming to rectify.

It is also important that the extent of the FAT is maximized. This will reduce the risk of problems arising during the final acceptance tests carried out on site and during system qualification. At this stage any dynamic testing considered for real-time computer process control systems will need to be undertaken utilizing simulation software, which in itself may need to be validated.

A satisfactory FAT report for the computer system also supports DQ by finalizing predelivery testing for the design and development phases of the validation life cycle.

## **P. Instrument Inspection and Calibration**

For the control/monitoring instrumentation, regulating devices, and any associated electrical equipment, predelivery testing and calibration is normally the responsibility of the instrument/equipment manufacturer and should be carried out to approved written procedures using calibration test equipment that is traceable back to agreed-upon national standards. The test equipment must have precision, accuracy, and repeatability that are higher than that of the instrument being calibrated.

The pharmaceutical manufacturer is not normally represented at supplier factory calibrations but for critical items should consider an option to inspect instrumentation and witness tests. Calibration certificates referencing the test procedure and test equipment should be sought, particularly for the instruments and regulating devices directly associated with quality-related critical parameter measurements and control.

Instrument factory inspection and calibration must define what is required to verify compliance with the instrument data sheet. It should cover:

- Operational requirements, such as working ranges and switch points
- Physical requirements, such as materials of construction
- Control characteristics and/or control logic requirements
- Process connection requirements
- Requirements such as supply voltage, signal type/levels, mounting, type of housing, cabling standards, and labeling

The procedure would typically include an inspection checklist, calibration procedure, test equipment stipulations, and documentation requirements (e.g., inspection certificates, calibration certificates, hazardous area certification, EMC/RFI certification, material certificates).

Instruments should not be released for installation on site until they have been inspected and calibrated in accordance with the approved procedure.

## **Q. Site Acceptance Test**

Once the computer system has been delivered to the pharmaceutical manufacturer's site and is installed and connected through field cabling and tubing to instrumentation (and possibly other systems) it is ready for site acceptance testing—this for both critical and noncritical parameters and functions. The in situ acceptance testing of the system under the SAT is a key element of engineering commissioning. For continuity, SAT test results should be analyzed and compared to the FAT results.

In addition to proving the system to a level required by GEP, the site acceptance responsibilities should also incorporate:

- Component unpacking, inspection, and storage
- Computer installation and power-up
- Instrument installation
- Instrument recalibration
- Loop testing
- As-built engineering drawings
- Installation report
- System operating and maintenance manuals
- Hand over to the pharmaceutical manufacturer

At this stage of a new installation it is possible that as-built drawings of the installation are still in a marked-up state. Marked-up drawings record the actual installation and should be submitted to the pharmaceutical manufacturer for review and approval before drawings are amended. The decision as to when to revise and reissue installation drawings can vary and will depend on the number of revisions, extent of revisions, and so on. A formal procedure is required to mark up drawings and control their use until drawings are updated and reissued.

Calibration of the instrumentation will be performed over the complete instrument loop. During each loop calibration, all data must be documented on appropriate instrument and loop calibration sheets and submitted to the pharmaceutical manufacturer for review, approval, and record. Calibration test equipment must be traceable back to agreed-upon national standards and documented on each calibration result sheet.

The calibration status and need for recalibration of instrumentation and associated regulating devices (see also Sec. VIII) during the implementation phases should consider the duration of the factory testing/delivery/installation period, manufacturer recommended frequency of calibration, and robustness and sensitivity of each instrument. The correct calibration of the in-line instruments, particularly those on critical parameter duty, is vital in achieving meaningful operational testing. For intelligent instruments (e.g., instruments that provide self-diagnostics and on-line calibration checking) the computer needs to provide appropriate records.

The site acceptance testing also provides an opportunity to identify and correct any problems due to shipping, utility hookup, hardware assembly, and field installation. The extent of SAT required can be determined by the completeness of the FAT, and as such is a full or partial repeat of the acceptance test specification with connections to the field instrumentation and regulating devices. Where it is not considered necessary to conduct a full repeat of the FAT, the rationale for this decision should be recorded in the qualification report.

The level of site acceptance testing should be such as to demonstrate satisfactory operation of the system functions in conjunction with the manufacturing process equipment and may involve control loop tuning. Site acceptance testing in its basic form should include installation checks, power-up, diagnostic checks, and commissioning of process and safety-related operational I/O, controls, sequencing, interlocks, alarms, and reports.

On satisfactory completion of SAT the system can be considered as available for plant operational commissioning. The computer system SAT report should document a high level of confidence in the computer system (i.e., the computer integrated with the field instrumentation and controlled function) in readiness for in situ site qualification testing activities.

Supplier acceptance test records and reports for both FAT and SAT should be approved and kept in the validation file.

Although supplier engineering contracts are usually fulfilled on satisfactory completion of the SAT, the performance of a computer system over a spread of data-handling conditions in the real-time environment of a manufacturing process is difficult to fully test at any one time. Consequently, consideration should be given to extending contractual conditions related to system performance into the system operational period, where the broader system performance issues can be better evaluated and reported.

In addition to demonstrating the state of readiness of the system, it is recognized that supplier acceptance testing as described above enables engineering commissioning activities and elements of in situ qualification testing to be combined. The pharmaceutical manufacturer may elect to do this when there is sufficient confidence in the system and process operation. Acceptance testing can also be considered as part of the training program for production operatives.

## VIII. SYSTEM QUALIFICATION

Qualification is the process of establishing appropriately documented verifications and tests that provide a high level of assurance that a computer system will operate in accordance with predefined specifications. The specific approach to be used for each level of qualification should be outlined in the project validation plan and needs to focus on the critical parameters, data, and functionality of the computer system. While there are no absolute lines to be drawn between qualification testing of a computer system, it is recognized that the qualifications listed below provide the necessary control and continuity throughout the validation life cycle and must be approved for the system to be released for use in the GMP environment.

- Design qualification
- Installation qualification
- Operational qualification
- Performance qualification

For DQ (also referred to as enhanced design review) this means review of documented activities throughout the supplier's design, development, and build phases and can include FAT. This is followed by verification and testing of the computer system in its operating environment, under IQ, OQ, and PQ (see Fig. 2).

In some instances elements of IQ and OQ may be executed in conjunction with, or as part of, SAT and the associated project inspection and commissioning activities (see Fig. 3). Alternatively, IQ and OQ will commence after SAT and engineering commissioning is complete.

It should be recognized that qualification activities need to be undertaken to detailed test procedures that provide comprehensive test records, with all documentation formally reviewed and approved by a designated level of management from the pharmaceutical manufacturer. With this in mind, suitably trained qualification test personnel will be required.

Whatever the approach, consideration should be given to avoiding duplication of effort, and where possible qualification verification and test procedures should use or reference system acceptance and engineering inspection and commissioning documentation.

### A. Qualification Protocols

The qualification protocol serves as a test plan to verify and document that a specific qualification has been satisfactorily completed. The qualification protocol and acceptance criteria are based upon the respective life-cycle specifica-

tions. The pharmaceutical manufacturer should have a documented procedure for the preparation of each qualification protocol.

The qualification protocol must be written and approved prior to execution of the protocol. Results of the executed protocol must be recorded and a summary report prepared.

To provide the recognized level of documented evidence qualification protocols should describe:

- Test objectives and prerequisites
- Responsibilities and signatories
- Test or verification method
- Traceability to specified requirements
- Test data collection and record
- Deviation procedure
- Test procedure
- Test data sheets
- Qualification review and report
- Supplementary data sheets

The tests should be designed to verify the existence of current and approved life-cycle and support documentation, verify system parameters, and test the technical functionality and quality-related attributes of the system, including safety, usability, and maintainability.

In detailing the test method, it can be beneficial to clarify the category of tests to be undertaken; for example:

- Positive tests: Those that prove a certain condition exists (e.g., conformity testing)
- Negative tests: Those that prove something cannot happen (e.g., challenge/boundary tests)
- Proof tests: Those that prove an event can only occur under specified conditions (e.g., shutdown tests)

Test techniques that are to be used can also be identified; for example:

- Valid case testing: A testing technique using valid (normal or expected) input values or conditions to prove the system performs as intended.
- Invalid cast testing: A testing technique using erroneous (invalid, abnormal, or unexpected) input values or conditions to verify that the system prevents nonspecified operations that may cause dangerous situations or adversely affect product quality.
- Stress testing: Testing conducted to evaluate a system or component at or beyond the limits of its specified requirements.
- Volume testing: Testing designed to challenge a system's ability to man-

age the maximum amount of data over a period of time. This type of testing also evaluates a system's ability to handle overload situations in an orderly fashion.

**Boundary testing:** A testing technique using input values at, just below, and just above the defined limits of an input domain; and with input values causing outputs to be at, just below, and just above, the defined limits of an output domain.

**Worst-case testing:** This encompasses upper and lower limits, and circumstances that pose the greatest chance of finding errors.

**Performance testing:** Functional testing conducted to evaluate the compliance of a system or component with specified performance requirements.

**Interface testing:** Testing conducted to evaluate whether or not systems or components pass data and control correctly to one another.

## **B. Qualification Test Procedures and Results**

To undertake each qualification, detailed verification and test procedures must ensure that the computer system is in accordance with the documented requirements and is traceable to specific specifications. These procedures may be included in the respective qualification protocol, along with clearly defined test acceptance criteria.

The computer system URS and FDS, the subsequent software and hardware design specifications, and instrument data sheets are the reference documents for qualification protocol development. The basis and acceptance criteria for each test should be derived from the system parameters, data, and function requirements that have been specified. It is advantageous to commence development of the test procedures at the same time as the respective specifications—this to best ensure that requirements and tests correspond, are traceable, and can be better understood.

Testing is to be conducted by designated test personnel. Each test result must be recorded (normally handwritten and initialed) by the person who conducted the test and similarly verified by a second person designated to check that the procedure has been carried out and the results are complete. Test results must be formally evaluated against the predefined acceptance criteria and the conclusions (e.g., unconditional pass or fail) recorded complete with an explanatory comment by a designated validation team member (normally the second test person). In instances in which a conditional pass conclusion is justified, this must be formally reviewed and rigorous controls imposed on the pass conditions. Approval and sign-off of the completed test records is normally the responsibility of the quality department representative on the validation team.

Any additional test data must be identified and appended to the test results. As appropriate, design reviews and the development and acceptance testing undertaken and documented by the supplier may be utilized to support the qualification effort and to optimize the resources required to achieve validation.

During qualification testing there may be instances in which the acceptance criteria for a particular qualification verification or test is not met. This must be identified (usually as a deviation) and the corrective action recorded, complete with plans for any retesting that may be required. The implementation of any resulting corrective action must be formally documented and test reruns approved and allocated a new test run number.

Test records should be kept in the validation file and used in preparing each qualification summary report.

### **C. Qualification Summary Reports**

Each qualification must be formally reported to ensure an approved and auditable transition to subsequent life-cycle phases. Qualification summary reports for the system must be prepared by the pharmaceutical manufacturer and should be kept in the validation file. Each qualification report should confirm the qualification test acceptance and review associated change control records. The report must present a documented record that clearly states the basis for concluding that the qualification is acceptable, particularly *if* there are any minor conditions or actions outstanding.

The report must review the test results, draw conclusions, and make recommendations for future action (as applicable). This may take the form of corrective actions in the event of deviations or a test failure, or additional procedures if use of this part of the system is conditional. The qualification report and conclusions should be approved by the same signatories that approved the qualification protocol.

A qualification report should include as a minimum:

- Report reference number
- Protocol reference number
- Signatories
- Start/finish dates
- Qualification team
- System and components identification
- Methodology
- Qualification results review
- Deviations status
- Change record review
- Qualification status statement
- Reference documents

Satisfactory completion, review, and reporting of each qualification, including those associated with field instrumentation and regulating devices, will release the computer system for the subsequent life-cycle phase.

#### **D. Design Qualification**

Design qualification is a formal and systematic verification that the computer system requirements specification is met by succeeding system design specifications and their implementation throughout the development and build (including development testing) activities.

Design qualification is normally a series of reviews of the software and hardware activities and documentation undertaken at appropriate stages throughout the design and development phase. The reviews need to consider all life-cycle design and development documentation and establish that software design, development, and testing is being conducted to written and approved procedures under a software quality assurance plan to meet operational and regulatory expectations. This ongoing DQ needs to address interpretation of user requirements by the FDS, system design specifications, system development practices, software review(s), all levels of software and hardware testing, and system release; identifying and reporting on the adequacy of the design and development, and provision of support documentation. A structured approach by the supplier to provide assurance that the system will perform as intended and is adequately documented for the GMP application will allow the pharmaceutical manufacturer to streamline its involvement in this phase.

The documentation for system design and development activities complete with development test results is normally prepared by the supplier. At a minimum, copies of the document reviews and a listing of the application development records should be provided for appending to the pharmaceutical manufacturer's DQ report. The pharmaceutical manufacturer may request copies of the supplier's application development and test records for inclusion in the validation file or arrange for the supplier to maintain and store all system application development records.

The DQ may also embrace the technical, quality, and commercial review of the inquiry/tender package conducted and documented by the pharmaceutical manufacturer. This is beneficial not only in checking that the computer system requirements have been adequately defined and are complete, but also in providing formal approval before the inquiry/tender package is issued and significant resources have been committed to implementing and validating the system. Any problems identified with the requirement definition at this stage can be more effectively resolved and the likelihood of omissions reduced.

A documented review undertaken with the vendor(s) to compare their FDS with the user requirements is necessary to record correct interpretation and un-



derstanding by both the vendor(s) and the user, and to verify traceability of requirements between the specifications. A key objective in comparing the URS and FDS is to confirm that an auditable system of documentation has been established that can be easily maintained throughout the validation life cycle. This will ensure controlled transition, with fully documented records, into the design and development phase that is normally carried out at the supplier's premises. Another important task is to identify system functions that are directly related to GMP and ensure implementation requirements for these functions are examined and reported in the GMP risk assessment for this step of the validation life cycle. (See [Fig. 3](#) and [Sec. IV.](#))

The use of a predefined checklist based on the URS to review the vendor documentation will assist the exercise and record that the key issues have been addressed in each one of the documents. The review team can also use the checklist to ensure that requirements are not duplicated and causing ambiguity.

In addition to the URS and FDS, other documents that are candidates for a requirement review include:

- Project validation plan
- GMP risk assessment(s)
- Supplier prequalification response
- Supplier audit report
- Project and quality plans
- Software quality assurance plan
- Commercial and purchasing specs.
- Supplier contract

The contract with the supplier may also be reviewed to verify the document deliverables and responsibilities.

On satisfactory completion of the requirement review and issue of an agreed-upon FDS by the chosen supplier, the design activities can proceed. Throughout design, development, and system build, the supplier, under its project and quality plan, must allow for review of life-cycle activities and documentation in support of the pharmaceutical manufacturer's DQ.

From this point in the design and development it is normally the supplier's contracted responsibility to lead the review activities and to provide all documentation and information necessary to undertake each review. To best ensure that the requirements detailed during the definition phase are fully covered by system design and development, the key review sessions should have appropriate representation from the groups primarily involved with the system application and operation and should verify adherence to the supplier's project and quality plan. This involvement will afford the pharmaceutical manufacturer a better understanding of the documentation that details how the supplier is meet-

ing the functional design stipulations, and this in turn will assist the software review(s).

Considering the activities required to systematically develop and test software and hardware, it is not unusual to have a series of reviews throughout the development and testing of software modules and hardware components, culminating with system assembly and integration. Review of the preparation of the instrument application engineering documentation and drawings should also be carried out, especially in relation to critical parameters. This approach will ensure that any problems or misunderstandings are identified early and enable effective resolution before software development and system build recommences, and will also provide a set of review documents that can be referenced in the DQ report.

At the end of system development testing and build activities the supplier will demonstrate how the computer system meets each requirement as defined by the FDS. This is normally contractual acceptance testing in the form of FAT and the SAT, and is witnessed by the pharmaceutical manufacturer with the intention of formally documenting that the system meets its design requirements and is ready for on-site qualification testing. Depending on the application and the project approach the DQ may be completed before or after the engineering SAT. If the approach is to finalize and report DQ before the SAT, then the SAT will need to be satisfactorily completed as part of or prior to commencing IQ.

The DQ report will address the actions and findings of the design and development review(s) and an agreed-upon level of formal acceptance testing. Satisfactory completion and documentation of the system design and development will allow the DQ to record that individual elements of the computer system have been adequately designed, developed, tested, and documented to meet the predefined specifications.

A review of the GMP risk assessment regarding previously identified critical system parameters, data, and functionality should also be undertaken at this time and reported as a section in the DQ report (see [Fig. 3](#) and [Sec. IV](#)).

Documents generated for consideration in the DQ include:

- Requirements review documentation
- System design specifications
- Software design methods
- Software review(s)
- System flow diagrams
- Test procedures and records
- Software release/replication procedure
- Instrument data sheets
- System and installation drawings
- Deviation status list

- Requirements traceability matrix
- Configuration management records
- Change control records
- User operating manual
- System manager manual
- FAT report
- Instrument calibration certificates
- SAT report

On completion of the DQ process the pharmaceutical manufacturer's qualification summary report must record the completion of the DQ and acceptance of the system at site for the in situ qualifications required by the validation life cycle.

Installation qualification should not commence until the DQ summary report has been approved.

## **E. Site Instrument Calibration**

As life-cycle qualification activities move to the in situ operating environment a methodical approach for the site calibration of control and monitoring instrumentation is needed to provide suitable calibration and any associated records for the loop instrumentation and regulating devices on critical parameter duty.

In addition to inspection and calibration of instrumentation carried out as part of an SAT, the need for recalibration of critical instruments prior to IQ, OQ, and PQ should be reviewed and the decision documented in the respective qualification report. All site calibration activity should be conducted in accordance with quality standards and the respective engineering procedures. Any remedial work should be undertaken under document control, and where necessary, evaluated under change control.

A written procedure must be in place to ensure:

- Identification and labeling of instruments critical to the process.
- Calibration to traceable standards.
- Calibration at a predefined frequency.
- Auditable calibration records are maintained.
- Out-of-tolerance results are formally investigated.
- Review of the satisfactory completion of the calibration procedure.

Calibration of critical instruments and system components must be controlled by a calibration schedule in order for call-off dates to be determined. The calibration periodicity should be determined by the process owner, its quality representative, and the maintenance engineer, taking into account the manufac-

turer recommendations and the robustness and duty of the instrument. In general, critical duty instruments are initially calibrated on a biannual basis (at a minimum) until there is sufficient historical data to determine reliability. The calibration status of critical instruments must be available and verifiable at all times.

Instruments must be calibrated to the appropriate site instrument calibration procedure using calibration and test equipment traceable to accepted national or international standards. Calibration procedures should be produced for each unique “type” of instrument. An instrument calibration procedure should:

- Identify instruments to which the procedure applies and any instruments of the same type that are specifically excluded.

- Identify precautions to be taken when carrying out the calibration and the source of any hazard.

- Describe the type(s) of instrument covered by the procedure.

- List the documentation that should be available before calibration commences.

- Describe the test equipment required to carry out the calibration test, including its name, model number, asset number (as applicable), range and accuracy, and any other applicable information.

- Describe the conditions under which the calibration must take place and identify the services required.

- Describe the detailed procedure to be followed to check the calibration of the instrument over its certified operating range and process failure limits (to ensure that it is within the tolerances specified in the manufacturer instruction manual and aligns with the requirements specified in the respective instrument specification/data sheet).

- Describe in detail the procedure to be followed for recalibrating an instrument that is found to be out of calibration when tested.

- Provide the calibration test sheet(s), applicable to the instrument under test, that should be used to record all test data necessary to satisfy the specified calibration requirements.

The results of calibration tests must be properly documented in accordance with the requirements of the manufacturer and/or the applicable national or international standard for the instrument before it can be considered calibrated.

The calibration test sheets form the evidence necessary to demonstrate the accuracy of data gathered during product manufacture and as such are key inspection documents. Critical instruments must be provided with a calibration test sheet/certificate that details both the test results and their limits of uncertainty. Calibration test sheets must be checked and approved by an authorized person.

Deviations from approved calibration standards on critical instruments must be reported immediately and investigated to determine if this could have adversely affected earlier testing or product quality since the last calibration.

If an external calibration laboratory is used it is important to review the scope of its certification with regard to any instruments that may be excluded.

Calibration records are normally stored in a dedicated calibration file along with the calibration procedures and calibration schedule. The location of calibration records (e.g., the engineering maintenance filing system) should be recorded in the validation file.

## **F. Installation Qualification**

Conditional on satisfactory on-site inspection, assembly, installation, SAT, critical instrument calibration, and design qualification, the computer system is available for the in situ qualification phases.

Installation qualification is documented verification that the computer system (including all required software) is installed satisfactorily and is compliant with appropriate engineering codes, manufacturer recommendations, and approved specifications, and that the instrumentation is calibrated and all services are available and of adequate quality.

The IQ may require powering up the system and conducting a level of safety, environmental, and operation checks, and can be performed in conjunction with plant/equipment start-up commissioning.

The IQ testing will require a number of test and verification procedures to be satisfactorily carried out and documented to ensure all components of the computer system are correctly installed and recorded, demonstrating that the computer system is in a state of readiness to proceed to OQ. To accomplish this the following verification/test procedures must be covered by IQ protocol:

- Validation file
- Security access (area and system user)
- Environmental
- System diagnostics
- Hardware component
- Instrument installation and calibration
- Electrical power and circuit protection
- Instrument air supply
- Loop wiring/tubing and cabling
- Hardware configuration
- Software installation
- Software configuration
- Software backup and restoration
- General system inspection

The order of testing should be considered to ensure any instance of retesting is minimized, (e.g., document records need to be verified before documents can be used in other verifications/tests, and access security should be satisfactorily tested before system access is required for other qualification activities).

The IQ will include examination of all applicable documentation information, and for the verification of computer system records documents may be categorized as follows:

Qualification documentation: Documentation that must be present and on file before executing the remaining sections of the IQ protocol

System documentation: Documentation that must be present and on file in order to adequately record the computer system

Support documentation: Documentation that provides background information about the computer system application, but that is not essential to the execution of the IQ protocol or required to adequately document the system

Documentation will typically comprise validation life-cycle documents and procedures, SOPs, training records, quality records and procedures, process and engineering data, drawings, manuals, and spares list(s), and includes copies of the software. These originate from both the pharmaceutical manufacturer and the supplier. The documents must be verified as approved and on file under a document control system. The documentation must be located or stored in a controlled environment.

For hardware components, documentation detailing the performance capability, compatibility, and assembly must also be available, along with manufacturer model and version numbers and the serial numbers where available. Pre-assembled hardware that is sealed does not have to be disassembled if this breaks the warranty. In such cases the details may be taken from the hardware specification/data sheet and the source recorded.

On issue of a satisfactory and approved IQ summary report the computer system can proceed to OQ.

## **G. Operational Qualification**

Operational qualification is documented verification that the installed computer system operates within established limits and tolerances as specified in the FDS.

The computer system must be powered up and checked to ensure it is functioning correctly. This may involve observing and recording system status lamps and/or rerunning diagnostic checks.

It is advisable to recheck the environmental conditions in which the system operates to ensure these are still within the manufacturer's recommended tolerances. Typical parameters that should be checked include

Air quality: temperature, relative humidity, airborne contaminants  
Ventilation filters and flow rates  
Radio frequency and electromagnetic interference (EMI)

Any abnormal conditions should be documented or reported and corrected prior to OQ testing.

Operation qualification involves a high degree of dynamic testing of the computer system in conjunction with the controlled process. It normally uses an alternative medium to represent process conditions, and can be performed in conjunction with plant and equipment engineering commissioning. Operation qualification testing may include both normal and abnormal operating conditions.

The OQ testing will require a number of test procedures to be satisfactorily carried out and documented to ensure all functions of the computer system are operating correctly and that the computer system is in a state of readiness to proceed to PQ. To accomplish this the following verifications/test procedures that focus on critical parameters, data, and functions must be covered by the OQ protocol:

- Operator interface and screen displays
- Input/output signals (including interfaces)
- Data storage, backup, and restore
- Electronic records and signatures, archive and retrieval
- System report printout
- Trend displays
- Alarms, events, and messages
- Process and safety interlocks
- Control and monitoring loop operation
- Software process logic and sequence operation
- SOPs
- Power loss and recovery

The order of testing should be considered to ensure retesting is minimized. Operator interface and screen displays are best tested before the system is used for other tests. Input/outputs need to be satisfactorily tested before other tests that are dependent on proven I/O signals, and trend display testing may be needed to support loop testing. For interfaces to other computer systems the main consideration is which system controls the access, selection, transfer, and use of validated data.

In considering electronic records and electronic signatures (ERES) the pharmaceutical manufacturer must address the system quality-related critical data collection and processing functions that come under ERES regulations (see Secs. IV and V).

Interpretation and intentions for ERES must be detailed in the validation plan, identifying the procedures to be used to verify and test compliance. These procedures must address both procedural and technological controls so that qualification testing demonstrates compliance with the clauses of the regulations that are applicable to the specific system GMP application.

Policies, training, and internal audits that support ERES should be verified, along with change control and configuration management records. To meet ERES regulations process control computer systems are now being developed with in-built configuration audit trail and software version management capability integrated with the system access security to provide automated revision history, version-to-version comparison, and version rollback, with configuration and runtime version linkage to enhance system integrity. Where applicable this functionality must also be tested.

Qualification testing of electronic records will need to:

- Verify GMP electronic raw data in the system
- Verify GMP electronic records within scope
- Justify electronic records not within scope
- Verify use of hybrid records
- Verify ability to generate paper-copy of electronic records
- Verify controls for system (“closed” or “open”)
- Verify electronic record-responsible persons
- Verify access and physical security
- Verify operational checks
- Verify secure and nonmodifiable audit trail (system to document change, who made the change, what was changed, reason for the change, entry date and time)
- Test data integrity (backup/restoration, archive/retrieval/retention, discern invalid record, electronic records cannot be deleted)
- Verify accuracy of generated hardcopy
- Verify management, record, periodic revision, renewal, and misuse detection controls for password authority to electronic records
- Verify (for “open” systems) the use of document encryption and appropriate digital signature standards to ensure record authenticity, integrity, and confidentiality

Qualification testing of electronic signatures will need to:

- Verify electronic signatures applied to GMP electronic records
- Justify electronic signatures not within scope
- Verify within-scope electronic signatures as communicated to regulatory authority
- Verify individual responsibility/accountability for electronic signature



- Test identification code/password or biometric electronic signature/devices (as applicable)
- Test immutable linking of electronic signatures to electronic records (including signatories' printed names, execution time and date, and meaning of signature; e.g., review, approval, responsibility, or authorship)
- Verify management, record (unique signatures), periodic revision, renewal, and misuse detection controls for electronic signatures

Approved SOPs must be in place before OQ commences. This will ensure operating instructions are performed in the same way each time and enable defined manual operations to be verified. Any revisions to an operational SOP (and associated documents) found necessary during OQ must be implemented under change control, and all affected documentation revised and reissued ready for retesting and use during PQ.

Operation qualification generally represents the first opportunity for plant operatives to use the computerized system in an operational condition and can be used as part of production personnel's training program on the system, plant equipment, and manufacturing process.

On issue of a satisfactory and approved OQ summary report the computer system can proceed to PQ.

## **H. Performance Qualification**

Performance qualification is documented verification that the computerized operation (comprising the controlled process and the computer system) consistently performs as intended in the URS throughout all anticipated operating ranges.

For computer systems that are an integral part of the operation of a manufacturing plant or process, the system PQ may be conducted in conjunction with process validation. The combined activities are generally led by the pharmaceutical manufacturer's quality assurance function and can be in the form of an extended process trial.

This life-cycle phase will normally involve all parts of the computerized operation, not just the computer system. It is therefore essential that other equipment such as operating plant, utilities, and services that are part of or related to the manufacturing process have also been qualified or commissioned to the appropriate level prior to commencing PQ.

Performance qualification involves performing a number of production runs (traditionally, at least three) that are considered to be representative batch sizes for the operation. These are to be conducted using pharmaceutical product and utilizing the computer system and services of production operatives as stipulated in the URS and plant SOPs.

Before PQ can commence both IQ and OQ must be complete, with any actions related to critical parameters, data, and functionality satisfactorily resolved and documented. The computer system should be powered up and checked to ensure it is functioning correctly. The environmental conditions in which the system operates should be checked. Any out-of-specification conditions should be corrected and observations recorded.

There may be a significant time lapse between the OQ and PQ phases, and as a result, consideration must be given to whether any control and monitoring instrumentation needs to be recalibrated. It is advisable to recalibrate critical instrumentation under the site calibration procedures and so guarantee correct calibration prior to commencing PQ.

Performance qualification testing for the computer system will include a subset of the tests performed during the IQ and OQ phases in order to demonstrate in conjunction with the plant equipment and operating procedures that the system can perform correctly and reliably to specification. Focus will be on documenting how the computer system performs in controlling, monitoring, and recording critical parameters, data, and functions, and how effective and reproducible the system is under varying process conditions and data loading.

As relevant, OQ test procedures can therefore be used for PQ testing. In particular, consideration should be given to tests directly related to data integrity and system repeatability with focus on critical parameters; for example:

- System access security
- Diagnostic checks
- Operator interfaces
- Software installation verification
- Software backup and restoration
- Control and monitoring loop operation
- Alarm, event, and message handling
- Safety and operational interlocks
- Software logic functions and automatic process sequence operation
- Standard operating procedures verification
- Data records and reports
- Power loss and recovery

The documentation gathered for the PQ review must provide evidence to ensure that as a minimum:

The computerized operation consistently fulfills the operational and functional requirements of the URS and produces quality pharmaceutical product to specification.

There is sufficient information available to enable the computer system (hardware and software) and associated instrumentation to be operated and maintained safely and effectively.

All instruments deemed critical for product quality and safety are calibrated according to approved site procedures.

Batch production records are correct and suitably signed off.

Operations and maintenance personnel are trained to use the computer system to operate the manufacturing process under an approved training program.

Operational SOPs related to the computer system are in place and in use.

Operational plans are in place and viable, and include data record archives, maintenance procedures, and contingency plans.

On issue of a satisfactory and approved PQ summary report, it is demonstrated that the computer system supports the computerized operation, and conditional on satisfactory process validation is available for use in the GMP operating environment.

## **I. Validation Report**

On satisfactory completion of the computer system qualifications, with PQ conducted in conjunction with a successful process validation, a final report must be prepared by the pharmaceutical manufacturer's validation team. This is normally referred to as the validation report. The objective of the report is to give an overview of the results of the execution of the validation program for the computerized operation and to draw a conclusion as to the suitability of the computerized operation for pharmaceutical manufacturing. This may be unconditional use or there may be restrictions. In the latter case the proposed remedial action(s) must be approved and, as applicable, considered under change control. A schedule to complete any outstanding actions must be documented and progress formally reported.

The validation report is a comprehensive summary that documents how the project validation plan has been satisfied. With reference to the qualification summary reports, the validation report serves as the approval document for all life-cycle activities and is the mechanism for releasing the computerized operation for pharmaceutical manufacturing use. Recommendations may be made for any follow-up audit or additional testing.

The report may follow the same format as the validation plan to aid cross-reference and must review all the key validation life-cycle documents. Any deviations and associated corrective actions should be reviewed, and any concessions on the acceptability of qualification test results examined.

The report should also preview the validation file documentation, control procedures, and support programs that are vital to the ongoing validation program and must be used as the basis for maintaining the validation status of the computer system. At this time a review of the GMP risk assessment should be undertaken and included as a section in the validation report.

The validation report should not be approved and issued until all control procedures and support programs are in place (i.e., system incident log, performance monitoring, calibration, preventative maintenance, document control, configuration control, security, training, contingency planning, internal audit, periodic review, requalification/revalidation, decommissioning/retirement). It is vital that the validation status of the computerized operation is not compromised.

The validation report must record all conclusions regarding the execution of the project validation plan, and for the satisfactory operation of the computerized operation in its operating environment it should be clearly stated as approved or not approved.

The pharmaceutical manufacturer must also set a regular review (e.g., annually) for ongoing evaluation of the computerized operation validation status.

## **IX. ONGOING EVALUATION**

The purpose of ongoing evaluation (also referred to as the operation and maintenance phase) is to ensure that the computerized operation maintains its validated status throughout its operational life and that GMP-specific records are readily available for a stipulated period after the system has been decommissioned or retired.

This phase of the computerized operation is usually the longest phase of the validation life-cycle, covering the operational period of the computer system in pharmaceutical manufacturing.

During this period, and as relevant, the validation file must be updated with current and approved validation documentation that continues to provide evidence of a controlled and satisfactory validation life cycle and that will enable inspection readiness.

### **A. Validation File**

The pharmaceutical manufacturer is responsible for maintaining the validation file and must ensure the computer system supplier(s) documentation is also up to date. The validation file document set must be under document control at all times, and is normally located in the pharmaceutical manufacturer's quality system to ensure controlled and expedient access at all times.

The validation file should have a file reference name and number and contain a document schedule or index with individual document titles, reference numbers, and version numbers. The file may also include electronic copies of documents (e.g., floppy discs, CD-ROM). Consideration should be given to

structuring the computer system validation file to reflect the validation life-cycle activities and include an introduction to the site, plant, process(es), product(s), responsibilities, and authorities. Typical document sets for the validation file are illustrated in [Figure 5](#).

Documents that cannot easily fit into the validation file or may be required on a day-to-day basis (e.g., supplier system manuals, calibration schedule, and records) may be filed elsewhere, and these should be identified on the document schedule stating where they are located and identifying who is responsible for them. All documentation provided by the supplier must be suitably marked to easily identify its location in the validation file. It is acceptable to have the system development records archived by the supplier. If the pharmaceutical manufacturer requires the supplier to store and maintain the documents there needs to be a formal agreement on the retention period.

## **B. Periodic Review**

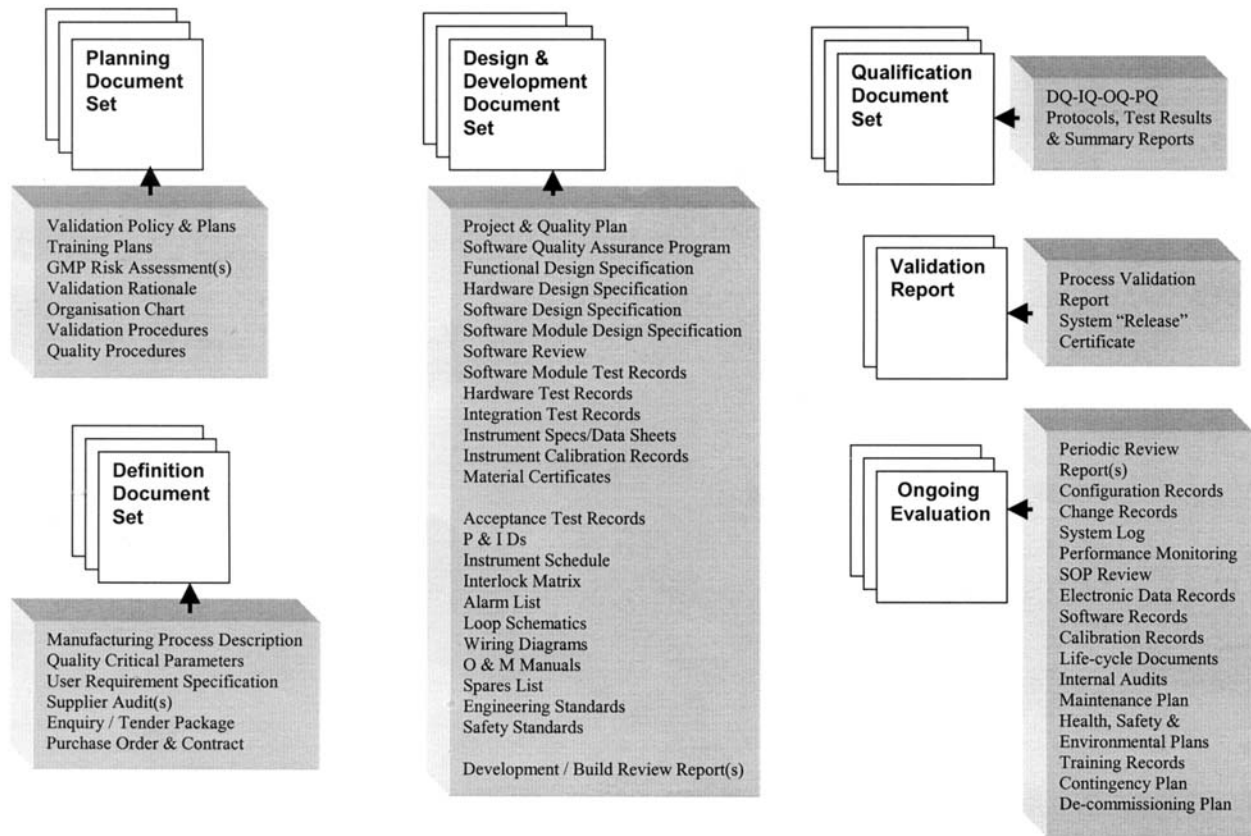
An important objective of ongoing evaluation is to uphold an auditable system of validation documentation and ensure a controlled, fully documented record of any activity that may affect the validation status of the computer system and the computerized operation it is part of.

Written procedures shall define how the system will be used and controlled, and periodic review of these procedures and the validation documentation status must be carried out. The periodic review procedure should define responsibilities and should include predetermined criteria for reporting that computer system validation is being satisfactorily maintained in alignment with the project validation plan. A GMP risk assessment should form part of each periodic review to reconfirm (or not) the findings of the previous risk analysis and provide information for any revalidation that is considered necessary.

The periodic reviews will be event-based or time-based exercises. Event-based reviews will normally be carried out if there is a controlled change made to the computerized operation that is outside the scope of the original validation and could impact on process or product quality attributes. This will normally be conducted in conjunction with the change control procedure (see Sec. IX.C), and should include a review of all relevant validation documentation to determine the extent of revalidation that may be required.

Periodic reviews may also be prompted by reported or suspected problems with GMP compliance. When a periodic review determines a deviation from approved conditions or practices this must be investigated and corrective action approved. If there is a need to redocument or retest the computer system, then the need for revalidation must be assessed and the resulting rationale documented.

Time-based reviews should be planned for at defined intervals to check adherence to procedures and the currency of validation records. The frequency



**Figure 5** Validation file documentation.

of reviews can vary, depending on the application, and at a minimum are generally undertaken annually. Such reviews can be supplemented by internal audits to spot-check correct use of procedures and control of validation support documentation.

Consideration should be given to periodic revalidation to ensure the computerized operation remains capable of achieving the intended results. The extent of revalidation will depend upon the nature of the changes and how they affect the different aspects of the previously validated computerized operation. Unless circumstances demand, revalidation does not necessarily mean a full repeat of the validation life cycle. As appropriate, partial requalification may be acceptable. For instances in which new qualification testing is undertaken it is advisable to retain the original qualification summary reports in the validation file or quality system archives, marked “superseded” with cross-reference to the new documents.

Periodic evaluation should take into account all relevant sources of information and data that demonstrate the suitability of the computer system performance, including but not necessarily limited to:

- Software/hardware changes
- Trend analysis
- Error and discrepancy reporting
- Incident logs
- Rework/reprocessing
- Process failures
- Product failures
- Customer complaints

In addition, ongoing evaluation should address the following through the periodic review procedure:

- Auditable validation life-cycle documents and software
- Procedures/records
  - Change control
  - Configuration control
  - Document control
  - On-site work procedures
  - System security (closed and open systems)
  - Data backup integrity
  - Data records archive/retention/retrieval (electronic records and paper copy)
  - Contingency planning
  - Revalidation
  - Decommissioning/retirement

- Training plans and records
- Operational/maintenance plans and records
  - Process SOPs
  - System incident log and problem reporting
  - Performance monitoring
  - Calibration
  - Preventative maintenance
- Health, safety, and environmental plans and records
- Operational environment issues
- Periodic review summary report

For electronic records the following should be addressed:

- Alarm logging, events, errors, real-time and historical trend data where used for regulatory purposes.
- Electronic data associated with configuration parameters.
- Electronic records that are printed to paper are linked to electronic form.
- Archived electronic records stored on maintainable media and in a format that can be read at a later date.
- Version control of software source and application code.

For the life-cycle validation documents and any associated support documents that make up the validation file the periodic review must verify that these are approved and auditable, and maintain traceability between related documents.

Operational and maintenance plans should be prepared for the computer system and its associated measurement and control instrumentation. Operational plan review will focus on system reliability, performance, diagnostic records, instrument and system I/O calibration, and the provision of critical data to support the batch record. Procedures for controlling the system (e.g., system management, security, and process operations) should be reviewed to verify that they are current, in place, and being followed. For each procedure required for the system there should be documented evidence that the relevant operatives have been trained in its use. All procedures must be written and approved according to the site procedures for writing and approving SOPs.

The maintenance plan will normally form part of the preventative maintenance system for the site and must be used to track all maintenance activities on the computer system and associated measurement and control instrumentation. For computer systems the supplier may be contracted for different levels of ongoing maintenance support, and it is acceptable to use the supplier procedures for maintenance of the specialist areas of the system. A supplier maintenance contract needs to define the scope of maintenance (e.g., the items to be maintained, type of activities, period of the contract, access requirements,



procedures to be followed in conducting, recording, and reporting maintenance, trained resource, and response times). Maintenance activities will cover three main areas.

**Normal operation**—The computer system is maintained in accordance with the planned preventative maintenance schedule. Typical activities include recalibrating field instrumentation and computer I/O cards in accordance with site calibration procedures, running system diagnostics, checking operator logs for any abnormalities, and planning service visits by the system supplier.

**Abnormal operation**—A failure occurs with the computer system or with the measurement and control instrumentation and an emergency repair is carried out either by site engineering or by the system supplier under the terms of the support agreement. In emergencies, immediate action may be authorized by the production department in conjunction with quality assurance, the problem, the action taken, and the updating of all affected documentation recorded retrospectively for change control assessment.

**Modifications and changes**—Planned modifications and changes during the life of the computer system and measurement and control instrumentation should be carried out in accordance with the site change control procedure.

### **C. Change Evaluation**

For any changes an impact assessment must be performed as defined in the change control procedure. This assessment will consider:

- Scope and rationale for the change
- Impact on product quality
- Impact on system validation status
- Requalification/revalidation actions
- Documentation to be generated
- Authorization level required

The assessment will then decide on the disposition of the change (accept, amend and resubmit, or reject). All approved changes should then be passed to a designated “implementation group” that will be responsible for ensuring that the change control procedure is followed.

The implementation group must align its activities to the validation life-cycle documentation to ensure the design and application engineering necessary to implement the change is conducted in a structured manner and to ensure any retesting of the system is conducted at a level necessary to embrace all change issues.

For changes to the computer system, appropriate representation from both the pharmaceutical manufacturer and the computer system supplier should be considered. The pharmaceutical manufacturer remains responsible for ensuring that the validation status of the system is maintained.

As the first step in implementing any controlled change on a computer system, the scope of work should be determined and documented. This will provide a comprehensive list of all controlled items, as well as any uncontrolled items that require modification as part of the change. This should include:

- Definition documentation
- Design/development documentation
- Qualification documentation
- Ongoing evaluation documentation
- System software
- System hardware
- Measurement and control instruments
- System security and data integrity

In most instances and due to the system validation life cycle, a modification to a high-level document will invariably affect lower-level documents. These lower-level documents are called “dependant documents,” and it is important to identify and update all affected documents.

When all the directly (and indirectly) affected items that require modification have been determined the components and functions of the system directly and indirectly affected by the change can be identified. At this point a review of the system GMP risk assessment(s) should be undertaken and the potential for revalidation addressed. Reference to the life-cycle model will identify the specification for each item and point to the qualification test procedure(s) that need to be considered.

The respective qualification or testing document should be examined to assess whether existing test procedures are suitable or whether enhanced or additional test actions and acceptance criteria need to be prepared. The rationale and required level of qualification testing for any revalidation should be documented in the change records and the validation plan suitably updated.

Following the requirement for identification of indirectly affected items it is logical to ensure that these are also tested to an appropriate level. In most instances the indirectly affected areas can be tested using a technique called “regression testing.” Regression testing is where the results of previous tests are compared with the results of postmodification tests. If the results are exactly the same then the indirectly affected item can be considered as operating correctly.

All revised documentation must be checked and approved by designated personnel and placed in the validation file. All superseded documentation must be marked as such and dealt with in accordance with site quality procedures.

## **D. Decommissioning**

The ongoing evaluation process should also consider system decommissioning in readiness for eventual system retirement. Initially a plan should be prepared to identify GMP requirements and the validation considerations for system retirement. Then, in readiness for the actual decommissioning, a detailed procedure is required specific to the current operation of the computer system and its GMP-related quality-critical data. Any retesting required in support of decommissioning is to be included in this procedure.

The decommissioning procedure must address both operational and safety aspects of the computer system application and establish integrity and accuracy of system data until use of the system and/or process is terminated. For quality-related critical instrumentation, proof of calibration prior to disconnection is needed.

The procedure should include review of all the collective information in the validation file to confirm the validated status of the system and ensure data records that are to be retained in support of released product are available. The requirements necessary to conduct and report the archiving of GMP records need to be defined, and should identify all life-cycle documents, electronic raw data, electronic records (including associated audit trail information), and system application/operating software that are to be archived.

It must be possible to reproduce the archived data in human-readable form throughout the retention period. Where applicable, the method of data transfer to any other system must also be formally documented and controlled.

Computer system decommissioning can also encompass disconnection, disassembly, and storage (or mothballing) for future use. Accurate specification, design, development, qualification testing, and operational documentation is essential to enable controlled redeployment of the system in a GMP environment.

## **E. Periodic Review Report**

A periodic review meeting should document the review process, documents reviewed, comments from attendees, and the collectively agreed-upon course of action. The periodic review summary report should record the findings of the review meeting and include an action schedule itemizing any documentation that requires updating and those responsible for completing the work. The progress of updates should be monitored through the documentation management system against agreed-upon completion dates.

Following a successful periodic review, acceptance of the evaluation should be clearly stated in the periodic review report and approved by the system owner and signed by designated members of the validation team.

The periodic review report(s) should be retained in the validation file as a record of the computer system validation of the validation status and the validation plan should be updated with a date for the next review.

## REFERENCES

1. CFR Title 21 Part 210–211. Current Good Manufacturing Practice for Finished Pharmaceuticals. *Code of Federal Regulations, The Office of the Federal Register National Archives and Records Administration, Printing Office, Washington* (1995).
2. Medicines Control Agency (MCA). Rules and Guidance for Pharmaceutical Manufacturers and Distributors 1997, Part Four—Good Manufacturing Practice for Medicinal Products. The Stationary Office, London.
3. GAMP 4. Guide for Validation of Automated Systems. *ISPE* (December 2001).
4. PDA Technical Report No. 18—Validation of Computer-Related Systems. *PDA Journal of Pharmaceutical Science and Technology* 49: S1 (1995).
5. ISPE Baseline Pharmaceutical Engineering Guide for New and Renovated Facilities: Volume 5 Commissioning and Qualification, First Edition. *ISPE* (2001).
6. World Health Organization (WHO). Good Manufacturing Practices for active pharmaceutical ingredients (bulk drug substances). In: *WHO Expert Committee on Specifications for Pharmaceutical Preparations* (1992).
7. FDA Compliance Policy Guides for Computerized Drug Processing: CPG 7132a.07, Input/Output Checking (1982); CPG 7132a.08 “Identification of Persons” on Batch Production and Control Records (1982); CPG 7132a.11, CGMP Applicability to Hardware and Software (1984); CPG 7132a.12, Vendor Responsibility (1985); CPG 7132a.15, Source Code for Process Control Application Programs (1987); *Software Development Activities—Reference Material and Training Aids for Investigators*, National Technical Information Services, Springfield (1988).
8. General Principles of Software Validation; Final Guidance for Industry and FDA Staff. *U.S. Department of Health and Human Services, Food and Drug Administration, Center for Devices and Radiological Health, Center for Biologics Evaluation and Research* (2002).
9. Case Study A—Instrument Application Design and Validation. T. de Claire and P. Coady. *Validating Automated Manufacturing and Laboratory Applications—Putting Principles into Practice, Part 2 Case Studies*, Guy Wingate. Interpharm Press (1997).
10. STARTS Guide (Software Tools for Application to large Real-Time Systems). Volumes 1 and 2, *Department of Trade and Industry, and UK National Computing Centre, NCC Publications* (1987).
11. The TickIT Guide—Using ISO 9001:2000 for Software Quality Management System Construction Certification and Continual Improvement. *British Standards Institution* (January 2001, issue 5.0).
12. PDA Technical Report 32. Auditing of Suppliers Providing Products and Services for Regulated Pharmaceutical Operations. *International Association for Pharmaceutical Science and Technology* (1999).
13. Complying with 21 Part 11. Electronic Records and Electronic Signatures Version 1. *Good Practice and Compliance for Electronic Records and Signatures, Part 2, ISPE and PDA* (2001).

# 17

## Integrated Packaging Validation

**Mervyn J. Frederick**

*NV Organon–Akzo Nobel, Oss, The Netherlands*

### I. PACKAGING VALIDATION: INTRODUCTION

#### A. Introduction

The traditional way of operating a pharmaceutical packaging system has been to sample and test everything and to “inspect out” the defects. This usually left out important influencing features, such as the interface between the packaging materials and the equipment or environment in which the packaging takes place (e.g., effects of relative humidity in the storage room and the packaging environment).

Nowadays the target is invariably the achievement of a quality packed product (i.e., one that meets the specifications in the widest possible sense), and validation is a major tool in accomplishing this.

The aim of validation is not to correct or detect deviations in the packed product but to *prevent* deviations in the final packed products as far as is practicable and economic. The whole package in all its aspects must be considered from its manufacture throughout packaging of the drug substance to delivery to the patient and beyond (for environmental reasons). Some of the areas associated with packaging are listed in [Table 1](#).

With so many factors involved—some of which are conflicting—a good system of operation to ensure optimal, consistent performance is needed.

The review of validation studies on various drug products has a high priority for the regulatory authorities during preapproval inspection and routine biannual inspection.

The FDA has stated that it expects process, packaging, cleaning, and analytical and related computer validation studies to have been conducted, reviewed, and approved for both drug dosage forms and the bulk pharmaceutical

**Table 1** Areas Associated with Packaging

---

Design of primary container and the incoming packaging
Design of incoming primary container packaging
Design of secondary container(s) and the incoming packaging
Design of tertiary container(s) and the incoming packaging
Design of closures and the incoming packaging
Other incidental materials and components used in packaging (e.g., printing tapes)
Specifications (quality and information)
Tolerances
Process parameters and instrument control
Quality control and quality assurance
Analytical control, testing, and equipment
Vendor's contribution, the packaging line environment
Packaging line equipment settings
Cleaning
Compliance and safety
Stability testing and compatibility with contents
Laws (legal, pharmaceutical, environmental)
Standard operating procedures (SOPs)
Computers
GMP

---

products. Validation must provide assurance that all critical steps in each process (manufacturing, *packaging*, testing, etc.) are consistent and reproducible by putting in place controls to ensure that the process parameters are met.

Implementing integrated packaging validation that optimizes safety, integrity, strength, and purity will have more advantages than enhancing product quality. The economic benefit will usually provide good incentives.

The relationship of validation to GMP and quality needs to be reinforced, along with the interface with inspectors, regulatory authorities, and audit of finished product in the field. Auditing of suppliers is thus also needed to emphasize that validation is not an isolated exercise but part of an ongoing philosophy of continuously aiming for the highest achievable standards for all facets of pharmaceutical production and evaluating and controlling the changes to the system. The suppliers to the pharmaceutical company must be on the same wavelength as the validators.

Functional responsibilities of the various participants in the exercise of validation are issues that must be addressed. This must define the roles of the many participants in validation who need to be aware of and participate fully in order to ensure the successful conclusion of a validation to the benefit of the

company. Training schedules for both the process validation and the line/laboratory/office operators as well as for the writer of validation protocols are points that need to be covered.

## **B. Validation as a Communicator of Quality Requirements**

The responsibility of the validation function is greater than simply executing protocols and preparing reports. Validation is a technical communicating activity that understands the needs, collects information, and relays results. Good use of the expert skills of the members of a validation team contributes to meeting industry standards and regulatory requirements, thereby enhancing compliance and business resources in order to achieve efficient manufacturing systems.

## **II. SUCCESSFUL PACKAGING VALIDATION: INTEGRATED “SYSTEM” APPROACH**

### **A. Introduction**

Confidence is gained in validation and confusion is avoided when a systematic approach is used and the accent is placed firmly on “keeping it simple.” This is particularly true in small and medium-size facilities that do not have separate validation units, validation specialists, or long-term validation experience. Elements common to successful validation programs are presented below.

### **B. The Validation Team**

To be successful, validation is of necessity a team effort. The complexity and degree of detail required in validations that will meet compliance needs, require the involvement of individuals from numerous specialized fields. The systematic analysis of a process requires the participation and insight of these individuals united in a common target through the validation team effort. The first step is the formation of a validation team, which may consist of members of the following disciplines:

- Engineering/maintenance/technology (knowledge of the equipment and facilities)
- Production/operations (knowledge of the process requirements)
- Quality assurance/quality control (knowledge of what is acceptable)
- Regulatory affairs/compliance (knowledge of the rules)
- Research/development (knowledge of the drug product itself)
- Other specialists (e.g., packaging operations, appropriate for specific processes, systems, or equipment undergoing validation)

### C. Defining the Packaging Process

The process has to be defined clearly in order to be able to validate it. Proper definition will automatically include all operations contained in the process. Regulations require that the critical operations in a process must be validated, therefore all the processes and operations must be identified and defined. Using as a simple example the process of packaging aspirin tablets in a plastic bottle, the following operations occur:

- Tablet filling
- Capping
- Labeling
- Cartoning
- Bundling/handling
- Casing (shipper)

The following tasks form an essential step in validation:

- Identify all operations within the process.
- Define those operations that are critical.
- Define those operations that are noncritical.

### D. Critical Operations

In order to determine whether or not an operation is critical or noncritical, a set of consistent criteria must be used as a reference. The Food, Drug and Cosmetic Act makes this clear.

- Critical criteria—any operation that is determined to have a direct impact on the purity, quality, safety, or effectiveness of the product.
- Validation of critical operations is mandatory, whereas validation of non-critical operations is optional.

#### 1. Validation of Critical Operations

The basis of this “system” approach is presented as follows:

1. *Describe and define* the operations, system, or equipment to be validated. The operation or equipment should be analyzed carefully and then defined as precisely as possible. Since this definition will determine the requirements of each of the following steps in the process, no key item should be missing or forgotten.
2. *Identify* all major pieces of equipment or components involved in the operation or system. The operation is composed of equipment that is used for its execution. The validation document must identify the



equipment as well as demonstrate the output that may be evaluated as evidence that the system is under control. The equipment should also have the instrumentation needed to measure and monitor operational parameters that are used to support control of the process.

3. *Identify* the materials and components used in the operation. The validation document must identify the components with sufficient data to assess their condition after being subjected to the operation, as this usually serves as a demonstration that the process is in control.
4. *Identify* parameters and variables in the operation as critical and non-critical. The output of the operation is a function of the parameters that are used to control the process (e.g., speed, temperature, pressure, time).
5. *Identify* the typical operating ranges. The ranges at which an operation can perform are the boundaries of performance (e.g., maximum and minimum speed, maximum and minimum length, maximum and minimum temperature, or maximum and minimum quantity). Testing the output at these ranges is used to yield “normal” operating conditions, sometimes called a performance envelope.
6. *Identify and determine* performance/evaluation criteria. A key element in validation is the determination of what constitutes acceptable output, along with the determination that the quality of output is consistent with a process that is in control. Under “normal” operating conditions, there should thus be little variability in the quality of the output. Examples of easily measured performance criteria for the validation of the capping operation are cap torque and misaligned caps.
7. *Establish* test methods, test intervals, sampling, and accept/reject criteria. This point is critical for the success of the validation. The team must be careful to ascertain that
  - a. The test methods are appropriate and valid.
  - b. The test intervals are of a duration that will adequately demonstrate that the process is under normal production conditions.
  - c. Sampling is on a sound statistical basis and is consistent with established probability. There is no added value in drawing too many samples.

## **E. Writing a Validation Protocol**

The protocol is the experimental design by which the validation is executed and is the single most important document that a validation team can produce. The quality of the validation and its subsequent report is directly related to the quality of the protocol. Ideally it should be kept as simple as possible.

1. The format should be simple and clear and should provide for the incorporation of supportive documentation.
2. The protocol should include the critical specifications and operating parameters that were identified, such as the following:
  - a. Purpose of validation
  - b. Operation being validated
  - c. Major equipment involved
  - d. Components used
  - e. Parameters and ranges
  - f. Sampling and testing
  - g. Acceptance/rejection criteria
  - h. Deviations and corrections
  - i. Review and approval
  - j. Actions to be taken by failure
  - k. Responsible personnel and their function

It is important that the protocol has provisions for deviations and corrections, as well as cases in which an alternative test method would have to be used because of test equipment problems. This could prevent having to repeat the entire validation.

## **F. Assembling the Validation Report**

When the validation report is being assembled, most of the work of the team will in fact be completed, and the task only consists of adding supportive documents to the executed protocol. Basically a standard format can be developed for packaging validation at a given facility. The following suggestions could be included in the report, but this is subject to individual variations:

1. The protocol is the foundation of the report.
2. Supportive documentation should be added to the report, such as: equipment and facility drawings, technical and other specifications, test methods, suppliers' certificates, health authorities' approvals, approvals of components, and raw data results.
3. A summary and conclusion(s) section must be included.
4. The report should be reviewed and signed by authorized individuals.

## **G. Developing a Validation Master Plan: Documentation**

This master plan is used, managed, and enforced throughout the life of a process to help ensure quality. The document defines the validation approach, specifies the responsibilities of each of the validation team members, and is an important part of the overall validation effort at the beginning of a project.

The description of the following systems are necessary to control validation activities as well as the ongoing operation of the system, process, or equipment:

- Protocol and documentation preparation
- Protocol execution
- Documentation control
- Change control

## 1. Protocol

The “system” approach to validation includes the incorporation of information into formal written protocols, which serve as guides for executing the appropriate validation activities.

To ensure that specific criteria are set for all critical parameters, protocols should be developed for installation qualification (IQ), operational qualification (OQ), and performance qualifications (PQ). Again, they are generally only prepared for any systems, processes, or equipment that are defined as critical. More important than how these concepts are prepared is that the application must be based on a sound scientific approach.

The following general information should be present, although the contents of specific protocols will vary according to the application:

- Description of the system
- Qualification objective
- Scope
- Responsibilities and data collection procedures
- Test procedures, specific acceptance criteria
- Documentation procedures
- Summary and deviation report

## 2. Installation Qualification

This is the activity of collecting information to verify that the installed components are the ones specified, that they are properly identified, and so on, as stated in the construction documents in accordance with the specific requirements of the user.

An IQ protocol for a critical system generally should include the following information:

- Specification references, including purchase orders and contract numbers
- Verification of calibration of critical installed components
- Verification of procedures (e.g., operation, maintenance, cleaning, change control)

- Verification of major components
- Verification of control and monitoring devices
- Verification of utilities connections
- Change/replacement spare parts
- Lubricants
- Final drawings
- Reference drawings
- Reference manuals

### 3. Operational Qualification

This involves the testing of various components of the system, process, or equipment to document proper performance of these components. This phase may include verification of acceptable operating ranges for various components or equipment, such as critical utilities.

An OQ protocol for such a system should include the following:

- Verification of test equipment calibration
- Verification of controls and indicators
- Computer control system testing
- Verification of sequence of operations
- Verification of major components operation
- Verification of alarms
- Power failure/recovery testing
- Functionality testing of distribution system, valves, etc.
- System initial sampling

### 4. Performance Qualification

This involves challenging the system, process, or equipment to provide evidence of appropriate and viable operation. It should be performed over a long enough period to demonstrate that the system, process, or equipment is under control and will consistently produce a product with the desired quality attributes.

A PQ protocol should be designed to test and challenge the entire system, process, or equipment based upon its expected use.

It should include such tests as:

- System sampling
- Equipment cold-start tests
- System-invasive tests

### 5. Operating Procedures

Procedures must be prepared for all operations to be performed during the execution of a protocol. These procedures may be called validation operating procedures, SOPs, or operating manuals; the name is not important. These procedures

(documents) help to ensure that the system, process, or equipment is operated consistently during validation and exactly as it should during normal operating conditions. They must define exactly how verifications and tests are to be conducted.

Each document that is prepared for a validation program must be approved by all responsible parties. Documents that require data collection must also be approved after the completion of all required tests and verifications.

If alterations must be made to an approved protocol, a protocol addendum can be made, and after approval it can be integrated into the original protocol.

## 6. Change Control Procedure

This procedure is essential for the continual operation of the system, process, or equipment and provides a formal mechanism for monitoring changes during the continued operation of the system. Proposed changes that could affect the validated status of a system are reviewed by the validation team or responsible personnel and the proposed corrective action is approved.

## H. Final Report or Summary

The final validation report or summary is prepared after careful review of the data gathered during execution of the protocols. These data should be compared with approved acceptance criteria. The appropriate representatives of the validation team are usually those who approved the protocol and review and sign the final report and associated accompanying documents.

## I. Conclusion

Validation will make it more likely that an activity or process will be executed correctly the first time.

Since quality is the ultimate target, the most critical part of the validation is determining what must be tested or verified to ensure the appropriate level of control that results in a quality product. Avoid too much bureaucracy. Concentrate on the technical, science-based approach, enhance good communications, and keep it simple.

## III. VALIDATION IN PRACTICE: ESSENTIALS FOR VALIDATING PACKAGING EQUIPMENT AND LINE PRODUCTION

### A. Introduction

Today's current good manufacturing practices (CGMPs) for regulating manufacturing in the food and pharmaceutical industries have been updated in the Code of Federal Regulations (CFR) under Title 21 and have been extended to include

medical devices and biologicals. The CFR covers equipment and process, and is an essential tool for proper validation of packaging line equipment.

A reminder of the FDA's definition of validation is useful here as it emphasizes the need for producing "documented evidence which provides a high degree of assurance that a specific process will consistently produce products meeting its predetermined specifications and quality attributes."

In this definition, the key words are documentation, specific process, product specifications, and quality. This automatically means that validation will play a vital role in guaranteeing the safety, identity, quality, and stability of all pharmaceutical, biological, and medical device products. We will now present an outline of the most important requirements for ensuring that packaging line equipment complies with the guidelines of the authorities.

## **B. Equipment: Overview**

A list of all the line equipment that can influence the quality of the final packed product must be made. Some of the equipment commonly used in the pharmaceutical and medical device industries is given below with a short description. The list is an example of a simple line and is not complete for other products, but the same basic approach can be used.

*Check weigher.* May be commercial or specially designed for very unstable packages. The packages or containers are gripped or supported on the sides by suspended belts on the check weigher, lifted from the conveyor belt, then returned to the conveyor belt after being weighed.

*Bottom coder.* A single print head, ink-jet printer for noncontact printing (marking, coding, and overprinting) on the bottom of filled containers.

*Security sealer.* For automatic application of preperforated polyvinyl chloride tubing. The security seal is fully and evenly shrunk around the cap by the heat tunnel. The shrink seal covers the shoulder of the cap to the neck flange of the container.

*Labeler.* Applies and imprints (pressure-sensitive) labels to moving containers, generally at the same speed and in the same direction of the flow of the product.

*Cartoner.* This may be automated and continuous-motion equipment that receives containers that are standing upright in single file on a feed conveyor. The patient leaflet is positioned by the rotary leaflet placer at the bottom of the infeed bucket followed by a container on the side. The presence of the container and leaflet is verified automatically, and a folding carton is checked in a corresponding bucket. This triggers a push arm to transfer the container and leaflet from the bucket into the erected carton.

*Shrink bundler.* This automatically overwraps bundles of cartoned con-

tainers with a shrink film, after which the combination is passed through a heating chamber in which final shrinking takes place.

*Case packer.* This collects and arranges the bundles in the required patterns, then pulls down a shipping carton from the magazine and loads the pattern into the erected case.

*Case sealer.* This applies tapes to the top and bottom of the case as required.

### **C. Installation Qualification**

Each piece of packaging line equipment must be examined for conformance to the specifications, materials of construction, and drawings. For each piece a utility survey must be performed to determine if all the requirements for the equipment have been met and whether or not each is properly installed. There should be documentation of the equipment characteristics, maintenance procedures, repair, parts list, and calibration.

An IQ protocol must be straightforward without omitting anything that is important but also without an overflow of details that make the document unworkable. An overview of essential items is given in [Table 2](#).

At the completion of the documentation, a final report should be drafted to indicate the conclusion and acceptability of the installation. The final report must be approved by the departments that approved the protocol. These are likely to be engineering/technology, production quality assurance/quality control and operations, and the validation manager. Approval of the final report by the relevant departments makes the way clear for proceeding with operational testing.

### **D. Operation Qualification**

Operational qualification is the step in a validation process that will ensure the reproducibility and acceptability of the packaging process. Formally, it is an investigation of the control of variables in any given individual piece of equipment or in a given subprocess. In this way it is possible to verify that the sequencing of events is in the proper order and that the process equipment is operating consistently within the design limits.

It is essential to have a draft of an OQ protocol in which the objective of the validation, acceptance criteria, and test procedure(s) are documented, however. Testing simply cannot begin before this document has been produced, at least in draft form. An overview of essential items is given in [Table 3](#).

### **E. Operational Testing (OT)**

Packaging equipment used for pharmaceuticals and medical devices may be subjected to a wide variety of test procedures by the manufacturers of the packed products. Although all these tests have their value, it is essential to remember

**Table 2** Installation Qualification Protocol: List of Essential Items

---

Equipment information sheets summary
Name and location of equipment
Model and serial number of equipment
Purchase order for equipment/contract numbers
Number and location of SOPs
Number and location of calibration procedure
Number and location of maintenance procedure(s) <sup>a</sup>
Materials that come in contact with the product
Lubricants
General comments
Safety comments
Identification of supporting systems
Alarms, interlocks, and controls
Drawings on file and referenced drawings
Critical process instrumentation
Reference instrumentation
Equipment manual
Critical spare parts list and change parts
Utilities connections verification

---

<sup>a</sup>Including cleaning, change control, and so on.

that all the requirements should follow the required guidelines and the proper documentation of results. [Table 4](#), presents an overview of some of the components that may be included.

*Controls, alarms, and interlocks.* The performance of the controls, alarms, and interlocks that were developed in the IQ must be observed and assessed, and the results must be documented during a simulated production run. For controls that do not function during routine operation, a manual intervention may be used.

*Compressed air.* The pressure of the compressed air supply should be measured during a complete operational cycle of the equipment. Record the pressure at the beginning, middle, and end of the cycle.

*Operational verification.* The equipment must be operated through a complete cycle and its performance compared to the SOP. Any discrepancies found between the intended/planned and the actual operation performance are documented.

*Lot number and expiration date verification.* The proper operation of the equipment is verified following the SOPs. The resulting imprinted lot number and expiration date must be clearly legible.



**Table 3** Operational Qualification Protocol: List of Essential Items

---

1. Title
    - a. Name of the item of equipment, model number, physical location.
  2. Study site
    - a. Location of the operational testing. Validation testing may occur at the vendor's facility followed by a confirmation run performed at the company's location.
  3. Study director name and job title
    - a. Individual responsible for the validation.
  4. Purpose
    - a. Objective of the validation testing.
  5. Exceptional conditions and deviations<sup>a</sup>
  6. Test functions
    - a. Objective
    - b. Acceptance criteria
    - c. Procedure
    - d. Evaluation of the conclusion for the test function
- 

<sup>a</sup>Exceptional conditions must be documented and evaluated for their effect on the validity of the test data. Deviations must be approved in writing by all persons responsible for initial approval of the protocol, and this must be documented in an addendum.

*Deboss coding and leaflet inserter operation.* A simulated production run is used to observe, assess, and document the performance of the debossing and the leaflet inspection mechanisms. The performance should follow the SOPS.

*Operational verification of packaging components.* A simulated production run is used to observe, assess, and document the performance of the equipment with packaging components. The behavior of the components on the equipment should be in accordance with the SOPs. Any discrepancies between the intended/planned and actual operation are corrected. After the corrections have been made, a simulated production run and the tests procedures are repeated and the results are documented.

Other tests that may be considered include the following:

*Line speed.* Validation must be performed at least at normal production line speed. If testing is limited to any one speed, however, validation of the equipment will have to be first repeated before production operation with equipment operating at higher or lower speeds. It is therefore advised to perform testing at both extremes of production speeds (high and low).

*Container sizes.* All container sizes used for production should be validated. Where time may be a limiting factor, the validation of the maximum and minimum container sizes is recommended.

**Table 4** Operational Testing of Packaging Equipment (from Example)

Operational tests	Check weigher	Bottom coder	Security sealer	Labeller	Cartoner	Shrink bundler	Case packer	Case sealer
Alarms, interlocks, and controls	*	*	*	*	*	*	*	*
Compressed air	*	*		*	*	*	*	
Operational verification	*	*						
Lot numbers and expiration date verification		*		*				
Deboss coding and leaflet inserter operation					*			
Operational verification of packag- ing components			*	*	*	*	*	*

*Container shapes.* To ensure proper performance of the containers on the packaging equipment, all shapes of containers should be validated. Again, when pressed for time the two extremes must be taken.

*Container quantity test.* Two methods for validating the test quantity can be proposed; the required method must be in the protocol. (1) Fixed time duration. An approved duration of time during which the packaging line operates is used. The equipment is run for the period specified in the protocol (e.g., 15-min cycle), then all the containers or packages produced are collected. These are inspected to ensure that (together with all packaging components) they meet the acceptance criteria of the test function. (2) Fixed number of containers. The equipment is run until an approved number of containers or packages as specified in the protocol is produced (e.g., 200). These are all collected and inspected (together with all the packaging components) to ensure that they meet the acceptable criteria of the test function.

## F. Final Report

The OQ final report is intended to summarize all relevant data that are collected during the validation run. The report gives a short description of all test functions and a discussion of the overall validation. This compilation is adequate documentation of assurance of the acceptability and validity of the packaging equipment. The basis for this assurance is the result of the data, test functions, and supporting documentation. A dossier in sections is provided in Table 5.

It is recommended that a binder containing the data be divided into the following sections (Table 5). A very brief guidance of the contents is as follows:

1. Index. Position at the beginning of the final report (dossier)
2. Approval sheet. This sheet is signed by the authorized personnel of the departments responsible for the protocol, and the completed sheet

**Table 5** Operational Qualification Dossier: List of Contents

---

1. Index
  2. Approval sheet
  3. Final report
  4. Approval protocol
  5. Test functions
  6. Raw data
  7. SOPs
-

indicates acceptance of the final report dossiers. The sheet is also positioned before the final report.

3. Final report. Personnel who are responsible for the preparation and review of the final report must sign and date it after the conclusion.
4. Approval protocol. This is included in its totality.
5. Test functions. The test functions are divided into the individual sections. A summary of each test is given, detailing the procedure, results, and conclusions. The personnel responsible for the preparation and review of each specific test must sign and date the appropriate section after the conclusion.
6. Raw data. The data that are generated can vary extensively, and depending on the type of final report, additional sections may be required. The kinds of subjects or data in these sections may include
  - a. Validation summary sheet
  - b. Test printouts from equipment
  - c. Report program summaries
  - d. Batch record data
  - e. Validation test data collection sheets
  - f. Calibration data
  - g. Validation logbook entries
7. SOPs. The procedures that were used to perform the validation, including the modified versions based on the results of the validation.

## **G. Conclusion**

All companies must recognize that validation of packaging line equipment is required by the authorities in order to provide documented evidence that their specific packaging processes will consistently meet specifications.

Organizing and performing IQ and OQ testing and presenting the data from the validation runs systematically into the final report (dossier) will ensure that the packaging equipment and process will comply with the requirements of the authorities (e.g., CGMP). This is an important part of demonstrating that the packaging of the product is safe and secure and that the product meets the claimed quality.

## **IV. VALIDATION OF STERILE PACKAGE INTEGRITY: OVERVIEW FOR MEDICAL DEVICES**

### **A. Introduction**

Packaging is vital in maintaining the state of a sterile product up to the moment that the packaging is opened for withdrawal or use of the product. The regulators expect manufacturers to test finished packages to confirm package strength,

seal integrity, sterility maintenance, and stability of the barrier properties in simulated use and during storage.

The manufacturer's test is to ensure beyond a reasonable doubt that the product remains in a sterile condition at the point of use. The validation of sterilization processes guarantees initial sterility, and package integrity testing verifies the continued sterility of the product device after processing, storage, and handling.

The validation of sterile package integrity begins with the development of a validation master plan. The plan should include the following:

- Procedures and documentation requirements for IQ, OQ, and PQ
- Calibration of equipment
- Number of samples
- Trial run procedures
- Materials
- Operators
- Manufacturing and environmental factors
- Recording and statistical analysis of data

## **B. Methods of Verification**

All the techniques that are used to verify package integrity have advantages and shortcomings. Material tests that demonstrate microbial barrier properties (while allowing gases to pass through the wall for sterilization purposes) do not necessarily relate to the final product packages that have to withstand the hazards of handling, distribution, and storage. There are no standardized methods for performing whole package tests, and the great variety of package sizes, shapes, and material types used make this also unlikely.

If parameters for the package design under consideration are established through PO, however, and adequate care is taken to ensure aseptic procedures for sterility testing, package microbial challenge testing can be effective.

The trend of packaging medical devices delivery systems as kits containing multiple components for use in a single (surgical) procedure will make whole-package microbial barrier testing more difficult, as sterility testing will be required on all components in the packages. When increased handling of the product is required, the risk of more false-positive test results will increase.

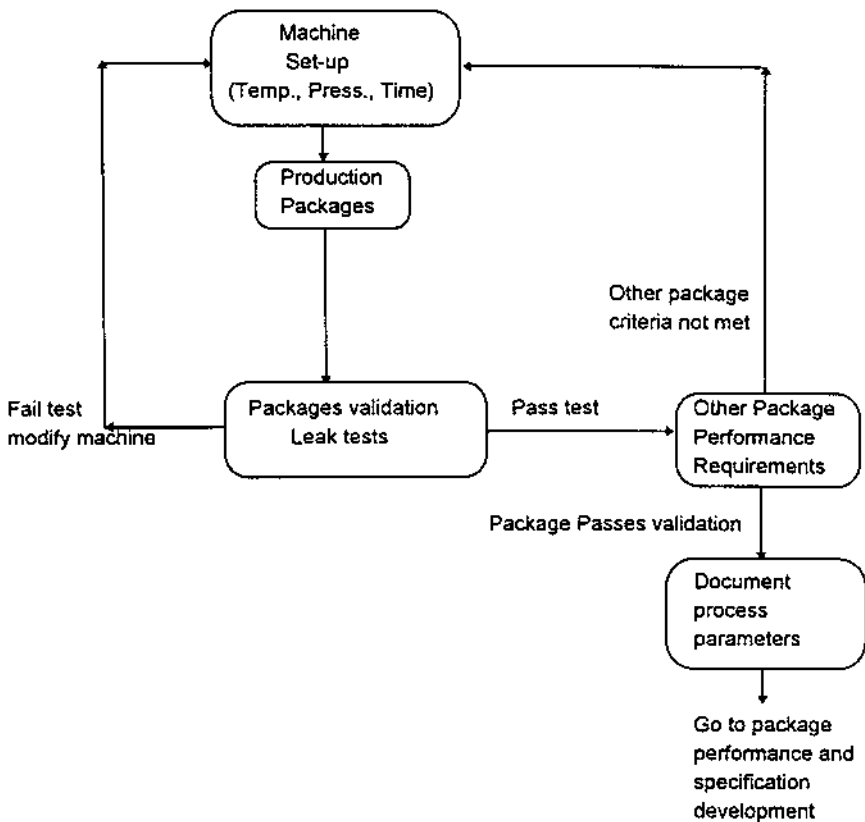
The authorities are increasing their demands for microbial challenge test data, and the FDA has a policy of direct techniques for evaluating the efficacy of packages.

## **C. Package Process Validation**

The initial validation of the packaging production process forms the basis for physical testing as a means of ensuring the sterility of the products. These test methods must determine the integrity of packages that have experienced “dy-

namic” events that are similar to normal handling and distribution (as compared to the established, known performance characteristics of the package) immediately after production. A scheme showing a typical approach to package process validations is given in Figure 1.

In the case of a heat-sealable pack, the manufacturer must first determine the contact ranges that result in an acceptable seal on the packaging machine. The principal machine factors for obtaining an acceptable seal are temperature, pressure, and time settings. They must then certify that during production of the seals, the operating parameters of the machine remain consistently within these ranges. Validation testing of packages should be performed at the upper and lower process limits of the machine or under worst-case conditions.



**Figure 1** Package production process validation.

Validation of the seal and material integrity may be performed through leak testing based on standardized methods, including the following:

- Positive pressure/submersion
- Vacuum/submersion
- Dye penetration
- Vapor/particle leak testing
- Visual inspection methods
- Light transmission tests

If package failure occurs during the initial validation, the machine settings and production conditions must be modified until packages that meet all performance, design, and application requirements are produced.

When acceptable packages or seals are produced under processing conditions, the settings and parameters of the machine and the physical characteristics of the packages are documented. Samples are taken randomly from the packaging line and tested to establish performance specifications for seal strength, seal quality, and burst strength. The specifications resulting from production/packaging process validation are documented and serve as the basis for maintaining control of the process through statistical quality control procedures.

The specifications are also the point of reference for comparing the integrity of the package after dynamic exposure, such as handling, shipping, distribution, and storage.

#### **D. Package Integrity and Performance Test Methods**

The seal and burst test values of identical packages produced on a specified validated production packaging line are useful data for performance specifications. The standardized methods of the American Society for Testing of Materials (ASTM) may be used.

1. Seal strength test: ASTM F88—Seal Strength of Flexible Barrier Materials. A specified width (1 in.; 2.54 cm) strip is cut from the seal of the package. Each side is clamped on a tensile tester and the peak force is recorded during complete separation of the material at the seal. Samples from several points on the package (as well as the material supplier's seal, when present) should be determined. The standard gives typical values for seal strength, but an optimum seal strength will depend on the type of package being tested and the specific application. This test does not measure the continuity of the effectiveness of the seal.
2. Burst test: ASTM D-1140—Failure Resistance of Unrestrained and Nonrigid Packages for Medical Applications. The standard provides

two methods for determining the ability of the packaging material or seals to withstand internal pressure. The burst test forms a basis for determining overall package integrity after dynamic events.

- a. Open package test. The open end of the pack is clamped in such a way that pressure can be increased into the package at a greater rate than the permeability (of porous components) until failure occurs. The type and location of failure and the pressure at which it occurred are recorded. This test is useful for incoming material inspection as part of the quality assurance procedures.
- b. Closed package test. This test is performed on production samples as an in-process quality assurance procedure. The sealed package is used. Pressure is inserted through a component and increased until failure occurs. The location and type of failure and the pressure at which it occurred is recorded. The standard gives typical burst test values. There is as yet no correlation between burst test and seal strength values. It has been shown, however, that the variation in expansion of packages produced from flexible materials can lead to inconsistent test results, and more consistent results are obtained by restraining the expansion of the packages; for example, by fixing them between parallel plates.

## **E. Sterility Testing**

Package integrity is validated by sterility testing. At present there are no recognized methods for performing a whole package microbial challenge; therefore the package may be validated indirectly (e.g., using methods for detecting physical leaks).

Several methods are commonly used to test sterility.

**Nondestructive method.** This involves determining packaging integrity by visual inspection of package seals, and is only suitable for packages with at least one transparent material component. It uses high-intensity light to observe the continuity and uniformity of the seal.

For packages incorporating heat seal adhesives, the attributes of integrity have a direct relationship with the process parameters, process equipment, and packaging materials. Visual inspections are very suitable for production in-process controls of quality assurance.

**Destructive methods.** For use in validating packaging for their integrity these include:

Positive pressure/submersion



Vacuum/submersion  
Dye penetration  
Vapor/particle leak testing

### 1. Vacuum Leak Testing: ASTM D-3078—Leaks in Heat Sealed Flexible Packages

The standard procedure is applicable to some medical device packages. The method is useful for detecting gross leaks in packages and may miss very small leaks. For porous packages that do not produce an internal pressure under vacuum due to escaping air the method may not work well. In addition, on releasing the vacuum, water may permeate the package. A nonporous pressure-sensitive label can be used to cover porous surfaces and make them impermeable, whereby the vacuum test may be effective.

### 2. Positive Pressure Testing

By applying positive pressure to a package submerged under water, gross leaks can also be detected by the issuing bubbles at damaged seals or pinholes in the nonporous component of the package. A degree of air permeation through the porous component is allowed on condition that it does not affect observation of leakage in other components of the package.

### 3. Dye Penetration Testing

This test is intended to detect channels, open pathways, or discontinuity in a sealed area specified as a critical primary barrier. Pinholes in nonporous materials are also detected. This method is suitable for both flexible and rigid packages and with porous and nonporous materials.

When a penetrating colored dye solution is injected into a package it detects channels or voids in the sealed area via capillary action and pinholes in nonporous materials via blotting on a paper tissue. Packs with at least one transparent component are more suitable for viewing the results. Dye penetration is more difficult to use on packages of porous materials, such as paper.

### 4. Injection of Particle Vapor Testing

Theoretically smoke or vapor injected under slight pressure from a smoke chamber into a package will find imperfections and channels in the seal and deposit particles at the locations of leakage. This method is difficult to perform, as the

results are subject to misinterpretation, and are of questionable value for general use.

## **F. Package Performance and Specification Development**

When the development and validation of the packaging manufacturing process are completed, the standard testing procedures (e.g., ASTM) should be used to ensure sterile medical device package integrity and the sterility of the product after additional production processes.

A guide for developing packaging performance characteristics and specifications is given in [Figure 2](#). In order to establish if any element or step in the development process causes a loss of package integrity, each step must be validated.

After the package performance specifications have been established, the effect of sterilization on package integrity must be evaluated. Some packaging materials or seals can be significantly affected by some sterilization processes. If packaging integrity is lost or changes occur during sterilization, the production process or packaging design will have to be modified. Again, before the final production of the packaging design can begin, it is wise to know what the effect of handling and distribution will be on the package. The packaged product's sensitivity to such hazards of transport as shock vibration should be assessed in separate tests. Then in the design phase, the accumulated effects of production, sterilization, and shipping can be determined by testing all stages in sequential order.

## **G. Final Package Validation**

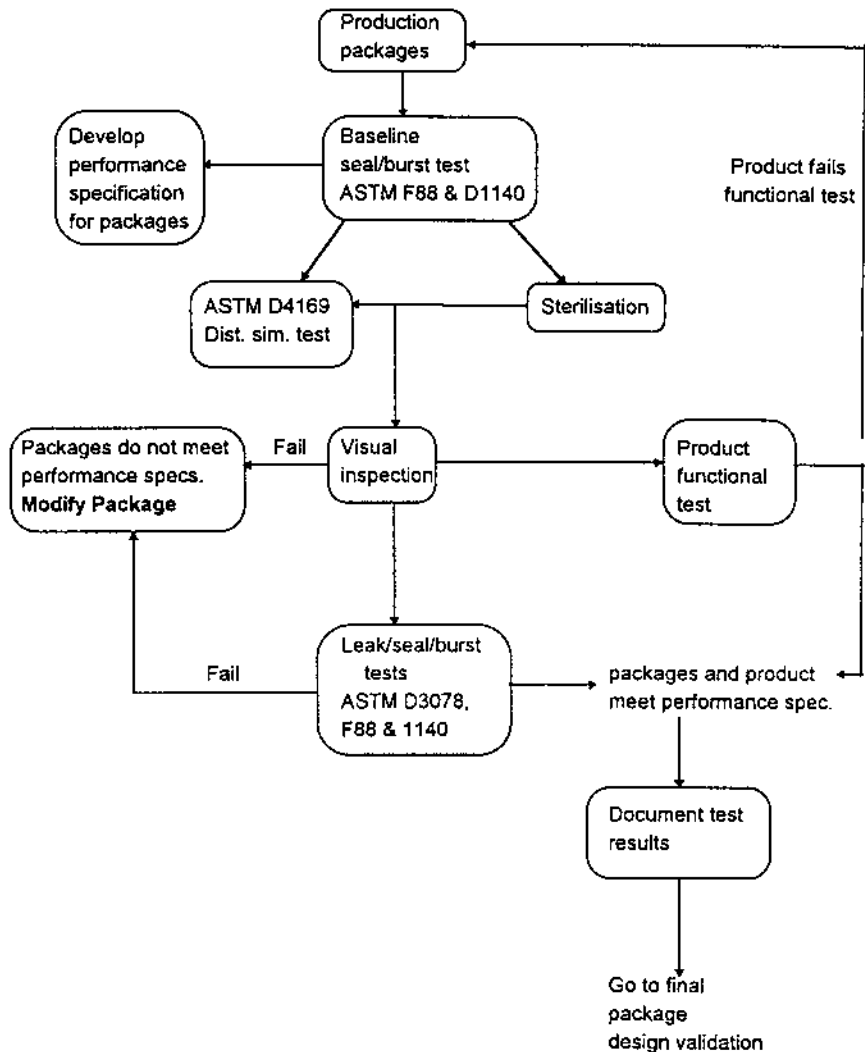
After the design and manufacturing phases of the package, the final validation may be performed on actual-production scale batches.

A protocol for assessing the integrity of a package after exposure to simulated hazards that the package will encounter during its normal life is given in [Figure 3](#). The exposure includes:

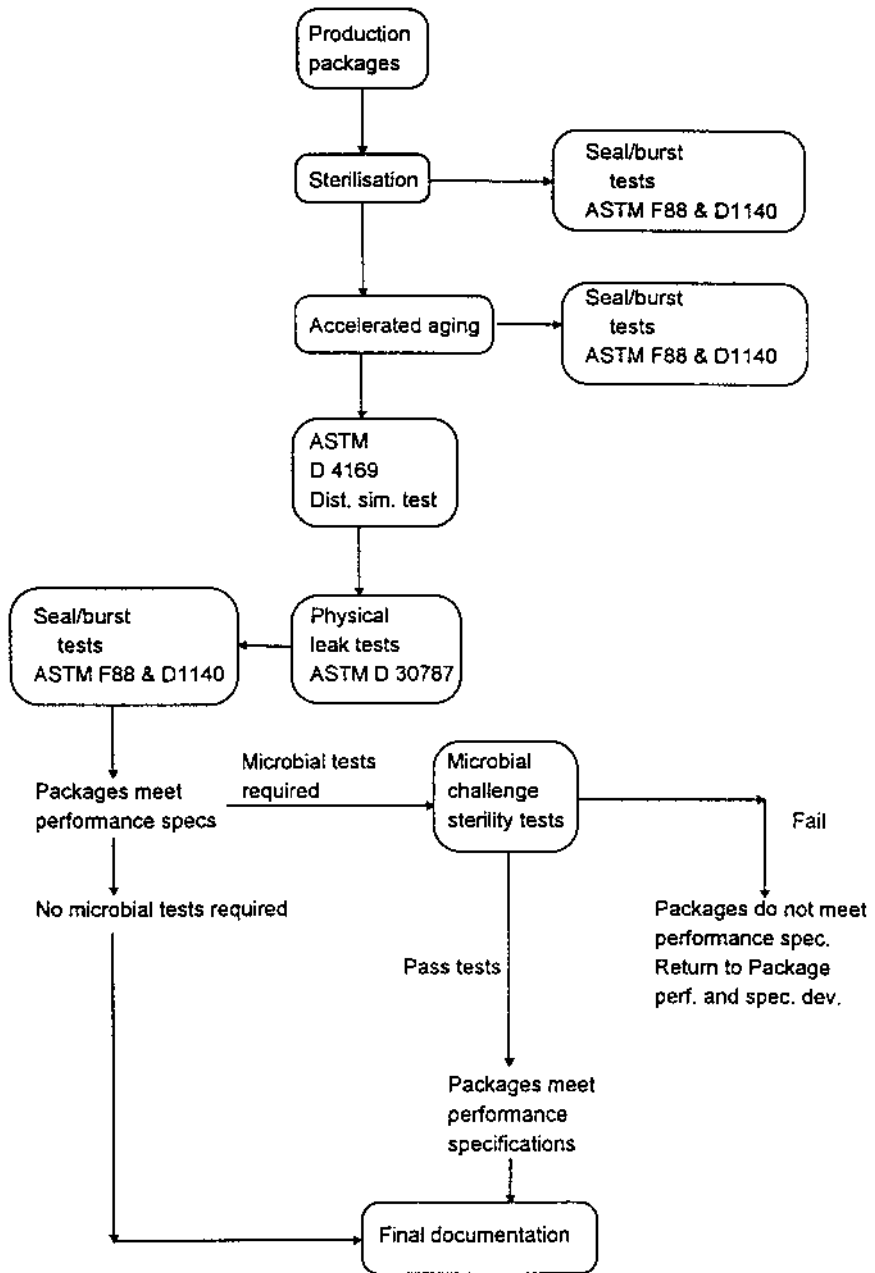
- Sterilization
- Aging
- Handling and shipping

## **H. Aging and Shelf-Life Testing**

Again, processes could affect the performance of the package by degrading its components or seal properties (e.g., brittleness, loss of adhesion), and thus lead to a loss of package integrity. The effects of aging can be determined after



**Figure 2** Performance and specification development.



**Figure 3** Package design validation protocol.

storage by repeating seal and burst testing and comparing the results to initial performance specifications.

The relationship between accelerated aging and real-time aging for packages has not been determined, and although the theory states that “for every 10°C rise in temperature the reaction rate of material doubles,” this should be applied with some caution for such materials as medical devices packaging.

The European directives indicate that labels must show “where appropriate, an indication of the date by which the device should be used, in safety, expressed as the year and month.” If expiration dates are given on the table, the data should be available to support the manufacturer’s shelf-life claim.

The authorities would probably require that investigations are set up to determine real-time long-term integrity of the package. Companies can develop their own packaging test protocols based on the regulations for a given device.

## **I. Shipping Tests**

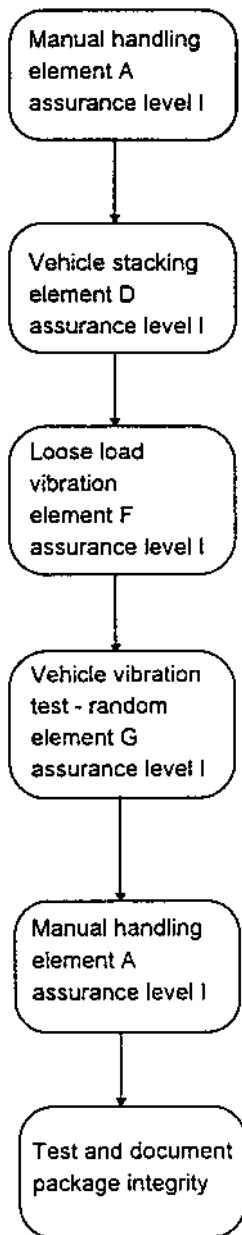
The most serious threats to package integrity are the potentially damaging hazards on the journey from the manufacturer to the end user and the extensive handling to which the package is subjected. Actual shipping tests (field trials) or simulated laboratory shipping tests may be used to subject the packages to the dynamic events inherent in shipping and handling (the ASTM D-4169’ performance).

Testing of shipping containers and systems is an accepted laboratory test that includes a testing plan covering hazards that may be encountered during distribution. An example of a test plan for subjecting a small parcel to shock, vibration, and compression at realistic levels of intensity during shipping is given in [Figure 4](#). After testing the shipping package containing a representative loading (configuration), the unit presentation or primary packages are assessed for integrity by the seal and burst tests given earlier. Attention should be given during seal and burst testing to evidence of weakening, fatigue, or degradation, and during leak testing to any obvious loss in package integrity and possible nonsterile conditions. At this stage the regulatory authorities may also require performing microbial challenge testing.

## **J. Conclusion**

The overall protocol for packaging validation remains the same whether microbial challenge test methods or physical test methods are used. At each stage in the development and production process of a package for a medical device package integrity must be verified.

When correctly selected and used, the methods for seal, leak, and burst testing are the essential tools available to the manufacturer to assist in providing



**Figure 4** ASTM D-4169 test plan.

a sterile medical device package that will ensure that the product reaches the user in optimum condition and therefore performs safely and efficiently.

## **V. INTEGRATED PACKAGING VALIDATION: THE PACKAGING MATERIALS**

### **A. Introduction**

#### **1. Definition of Packaging**

When considering easily damaged or perishable goods, packaging may be defined simply as the means of protecting the product so that it arrives at the point of sale or use in a satisfactory state.

The fact that many products (e.g., liquids, sprays, powders, gels, some drug products, and cosmetics) cannot exist or be transported without a pack, however, means that for these types of products a broader definition is needed to cover the functions of the pack and the packaging operation.

##### Packaging definition

Packaging is the means of providing

Protection

Containment

Presentation

Identification information

Convenience/compliance

For the full life of a product during

Storage

Transport

Display and use

Whereby the end results are achieved

Economically

With compromise

The pack is usually present in up to three layers.

*Primary pack*, or immediate container

*Secondary pack*, for information and additional protection

*Tertiary pack*, added for storage and distribution

The design of a package depends upon many criteria, such as:

The type of product

Route of administration of the product

Available materials and their compatibility with the product

Available equipment to achieve the final pack

How the pack is assembled

How the proof of consistency of production is achieved

## **B. Product Types**

The packaging will depend upon the physical state of the product.

*Solids.* Include tablets, capsules, powders, granules, lozenges, pastilles, suppositories, pessaries, pills, dressings, and dermal patches. May also include such devices as actuators.

*Liquids and semisolids.* Include oral liquids, injectable, aqueous, and oil-based liquids, emulsions, suspensions, dispersions, solutions, drops, lotions, creams, ointments, pastes, gels, liniments, aerosols and foams, suppositories, and pessaries.

*Gases.* Vapors, inhalations, vaporizers, propellants, aerosols, such gases as O<sub>2</sub> and CO<sub>2</sub>, and anesthetic gaseous products.

## **C. Routes of Administration**

*Oral.* Taken by mouth—include liquids, emulsions, suspensions, dispersion solutions, tablets, capsules, powders, granules, lozenges, pastilles, and pills.

*Local topical.* Applied to the skin—include creams, lotions, ointments, liniments, solutions, pastes, gels, dressings, dermal patches, and aerosols.

*Parenteral.* Given by injection—include liquids, large-volume parenterals, and small-volume parenterals (powders).

*Orifices.* Include eye, ear, nose, throat, rectal, vaginal, and the mouth as a route to the throat and lungs, orifices using suppositories, pessaries, drops, solutions, ointments, gases, vapors, aerosols, and inhalations.

## **D. Packaging Materials and Systems Used**

In order to achieve the objectives stated above, the properties, advantages, and disadvantages of the basic packaging materials *must* be fully understood so that when assessing a specification (or writing one) the limitations of the materials themselves are well recognized. The properties of packaging materials must be understood in order to achieve a successful validation.

### **1. Glass**

Glass packaging includes bottles, jars, vials, ampules, vitellae, cartridges, and syringes.



Glass is described by the following types:

Type I: Borosilicate (borosilicate that is sulphated)

Type II: Flint or soda glass that is sulphated

Type III: Flint or soda glass

Type IV: Lower-quality flint or soda glass (U.S.)

Most glass packaging can be supplied colorless or in a range of colors for pharmaceuticals, usually clear, amber, blue, or green. These are absolute barriers to all gases and liquid and biological contaminants, but their weak point is the closure (except, of course, in the case of ampules).

## 2. Metal

Metal packaging includes rigid cylindrical tins, collapsible tubes, cans for aerosols, valves, closures, and foils, most in various forms of aluminum, but some tinplate is still used. These have good barrier properties to all gases and liquid and biological contaminants, and are usually coated to prevent direct contact with the contents. As is the case with glass, the closure is the weakest part of the pack, and metals are also somewhat susceptible to corrosion in the long term in the presence of both moisture and oxygen.

## 3. Paper and Board

Paper and board packaging is used mainly for secondary and tertiary packaging (e.g., labels, leaflets, cartons, and cases). Various dressings, pouches, and medical devices have paper as a contact material.

## 4. Plastic and Elastomer

Plastic and elastomer packaging is used for bottles, jars, ampules, closures, plugs, films, sheets, labels, shrink sleeves, wads, cartons, and tubings. The barrier properties of plastics vary widely. Some detailed knowledge is required on the barrier of plastics to moisture, and to vapors and gases in order to make an optimum choice for a given product and application.

## **E. Equipment Available to Achieve the Final Pack**

The objectives of a pharmaceutical packaging line can be simply described as filling, closing, identifying, and providing protection to the product safely to a predetermined specification at an economic cost.

Other features associated with the packaging line:

- High, consistent output
- No rejects or wastage
- Low services, labor, and maintenance costs
- High integrity (e.g., no risk of mix-ups)
- High level of hygiene
- Minimum wear and tear
- Provision of safety for staff
- Effective operator and maintenance staff training
- Zero downtime due to stoppages
- Consistent quality
- Minimum depreciation
- Regular and effective maintenance

The three main factors needed for the typical pharmaceutical packaging line to function are:

- Materials—product and packaging materials supplied to agreed-upon specifications
- Services—electricity, compressed air, and so on to agreed-upon standards
- Personnel—effectively trained operators, engineering, QC, and other support staff

The activities of a typical packaging line may be divided into the following broad steps:

- Bringing the correct materials (both product and packaging) to the packaging line and delivery onto the line
- Packaging line services required to make the line operate
- Filling the product into the primary container
- Closing the package (i.e., the primary container)
- Labeling or identifying the contents of the primary container
- Adding leaflet(s) as required for all pharmaceuticals
- Using carton/display outer application (i.e., secondary packaging) if necessary
- Using collation casing and palletization for warehousing and distribution (i.e., tertiary packaging)
- Testing critical parameters online
- Documenting the performance
- Providing trained, motivated production and support staff

Considering the packaging line with many machines (or stations), the *most critical operation* usually operates at about the required output speed. In many cases this is the filling operation. The other machines upstream and downstream of this critical machine should be designed to operate faster than the critical machine to minimize queuing as far as is practicable.

## An Example of a Multimachine Line

---

Running speed (cpm)	Machine function
113	Unload packaging materials
110	Unscramble containers
105	Clean containers
100	Filling the product into the primary container
105	Closing the primary container
108	Labeling the primary container
110	Cartoning/leaflet addition (usually the same machine)
115	Collation of a standard quantity of primary containers
117	Casing of a standard number of collations
120	Palletization to a preset stack pattern of cases

---

*Note:* cpm = containers per min.

There also may be a requirement to have *accumulator* tables up- and downstream of the critical machine(s), each holding about 1 min worth of product (about 100 containers in the example above). It should also be noted here that the faster a packaging line goes, the greater the influences on the specifications of the packaging materials; that is, the higher the quality of packaging material that will be required and the higher the tolerances have to be.

## F. Combining Materials on the Line

### 1. Bringing the Materials to the Packaging Line

Is it necessary to bring together the product and packaging materials at the head of the packaging line in order to pack them?

Is the product particularly susceptible (e.g., sterile, moisture-sensitive, oxygen-sensitive)?

Are special environmental conditions required?

What level of cleanliness is required for the particular product (e.g., Is the product dusty or smelly)?

Are there factors that would indicate special extraction or other requirements on the packaging line?

There may be need only to fill, close, and identify the primary container (as used for many sterile filling operations) and then store the filled primary containers for later packaging. This can create many problems; for example

1. Type of identification to be used to ensure security
2. Storage of part finished packs [costs and specialist work in progress (WIP) stores]
3. Requirement for sealed containers for the WIP

All the above procedures have to be considered for validation.

## 2. Storage of Packaging Materials

All packaging materials should be stored before use for production under prescribed controlled temperatures and relative humidity (e.g.,  $20^{\circ}\text{C} \pm 5^{\circ}\text{C}$  and  $50\%$ ;  $\text{RH} \pm 10\%$ ).

**Temperature.** When moved into a warm atmosphere, cold containers, wads, closures, and so on will require time to adjust to the new temperature.

**Humidity.** If the humidity of the packaging area is higher than that of the storage area, condensation may form on the containers, wads, or closures, and any cellulose-based materials will begin to absorb moisture. It may take days (even weeks in the case of roll materials) to reach equilibrium with the filling area.

Factors that will need consideration in the storage and handling of packaging materials and components include the following:

1. The type of item; what physical and chemical changes might take place.
2. The way by which the items are packed.
3. The way by which the items are palletized and/or stacked.
4. The warehouse environment.
5. Whether or not the item is likely to deteriorate during storage. Does it need a limited shelf life backed up by a retest at given intervals?
6. Facility for QC sampling, how the sample taken and the pack resealed, inventory changes. Is random statistical sampling really possible?
7. The importance and level of cleanliness, hygiene, particulate contamination, bioburden, and so on.
8. Area segregation for quarantined goods.
9. Write-off procedures for out-of-date items. [Note: Goods should be destroyed or defaced if they are company-specific to prevent "pass-offs" (being used again).]
10. Environmental climatic changes between storage and production.
11. Lack of control on pallets. *All pallets should consist of the same batch.*
12. Contamination (e.g., due to spillage, roof leaking).

13. Physical/chemical changes due to exchange with other surrounding packaging materials (e.g., metal corrosion due to sulfur-based paper).
14. Awareness of the obvious: overhead heaters, radiators, drafts, leaking roofs, light/heat/cold from windows, metal buildings, black bodies (absorb heat).
15. Improper or inadequate packaging: overtensioned strapping, shrink wraps weeping, too tight stretch wraps, overstacking.
16. Components, containers, and materials of poor design.
17. Care needed when using recycled materials, since paper and board in particular lose strength.

### 3. Bringing Materials to the Line

All the materials for a particular filling and packaging order should be brought together in a secure area (sometimes called a collation area) away from the filling and packaging line and fully checked against an authorized specification for identity and quantity by a competent, appointed person. The auditor should also form a judgment on the cleanliness of the materials and be authorized to rectify any deviations and to report them. It is essential that the cooperation of the planning, purchasing, and stores departments is obtained in order to complete this detailed operation in compliance with the scheduled packaging time.

The general cleanliness of packaging materials is governed by the specification on the quality of the packaging used on the incoming transport of the packaging materials. Those packaging materials that are to be in direct contact with the product (e.g., containers, materials on rolls, wadding materials, and closures) should be supplied in packaging that prevents contamination, is easy to clean, is easy to unload onto the packaging line, and releases as little contamination as possible. All packaging should be designed to be easy to store and recycle.

### 4. Packaging Line Services

The packaging line cannot operate in isolation. It needs such essential services as clean, dry, oil-free air, electricity, gases (nitrogen, oxygen, fuel gas, steam, argon, laser gases), cooling water, sterilized water, vacuum, environmentally friendly extraction of waste gases, removal of used (unnecessary) material(s), removal of finished packs, drains, QC services, and engineering services.

Planning and inventory control have the task of ensuring that for any given order:

The services in the production building will all be available for the time needed for completion of the order (e.g., heat, light, extraction).

The requisite quantity of passed (released) materials are available for the job.

The requisite quality and quantity of labor is available, including the scheduling of line changeover. The presence of engineering, QC, and so on is available.

There is internal transport, warehouse space, and so on available for the finished goods.

## 5. Filling the Product

A product should be closed as soon as practicable after filling. The only major exception to this is the freeze drying procedure, whereby the container is filled with liquid, partially closed, and freeze dried. Then the closure operation is completed.

## G. Product Filling Systems

### 1. General Observations on Product Filling

1. Unloading the store's delivery of materials. How are they delivered, and is there easy access to loading points on the line? All loading points, safety off switches, running controls, and warning panels should be on the operator's side of the line. Operators should not be expected to crawl under, jump over, or run around the line for routine topping up of materials.
2. The physical state of the product will of itself lead toward the design of the filling technique.
  - a. Gas (liquefied and/or pressurized gas)
  - b. Liquid (sterile, viscosity, volatility, frothing)
  - c. Semiliquid (viscosity, separation, phasing into layers)
  - d. Solid (powder, granule, tablet, capsule, whose shapes might be regular or irregular, free flowing or sticky or fragile)
3. The mechanism of filling may be achieved in one of several ways.
  - a. Volume (cups, pockets, auger filling, pump, piston)
  - b. Weight (one shot, dump and trickle)
  - c. Level (vacuum, pressure, gravity)
  - d. Arrangement (blisters or column)
  - e. Count (recessed cylinders, slats, regular objects queued then breaking a photoelectric cell beam)

The cleanliness of the chosen filling techniques should be considered with the aim of avoiding those that produce potential contamination (e.g., drips, product seepage, powder agglomeration). There needs to be control of the following problems frequently encountered in filling:

*Aerating* liquids, semiliquids, and powders, usually caused by excessive high-speed stirring  
Compacting or dusting; powder explosion risk of solids needs to be noted  
*Separating* liquids, semiliquids, and powders into phases  
*Dusting and breaking up* tablets and capsules from being moved around for too long in hoppers and so forth

## 2. Container Based Filling

The containers must first be unscrambled. Watch out for induced dirt from friction, fracture of fragile containers, and static electricity from dry conditions and movement of plastics, which can attract small dust particles from the surrounding air. Most containers used for sterile filling (ampules, vials, bottles, and collapsible tubes) will be brought to the filling line in precleaned and sterilized trays, so unscrambling might not be necessary. There are also certain types of outer cleaned bottles that are supplied in clean layers, with the outer plastic protection removed online.

In most cases, the *nonsterile* containers *must* be cleaned in line (e.g., inverted, blown with clean, dry, oil-free, compressed air from a probe in the bottom of the container, then sucked out, with vacuum sited at the neck). The resulting dislodged particles are then sucked away from the container while the air probe is being withdrawn.

The containers will next require queuing and orientation. Here the tolerances of the container are critical to the control required for high-speed filling.

*Blister Packs.* Two basic types can be found in use for pharmaceuticals today—hot formed and cold formed.

**Hot Formed.** Thermoforming is the name given to this process in that often a thick sheet of plastic is shaped under heat and pressure, then cooled. This may be carried out by the use of negative pressure (vacuum forming) or positive pressure (pressure forming) with or without the assistance of mechanical (plug-assisted) forming. Since these processes start with a reel-fed or sheet-fed material of uniform thickness, any subsequent change in thickness can only be downward (i.e., thinner than the starting material).

The addition of plug assistance usually improves the control on wall thickness, hence in terms of control the general list below applies.

**Cold Formed.** Cold-formed materials (combinations of plastic layers special 40 to 45  $\mu\text{m}$  aluminum foil) are also used for pharmaceutical products [e.g., 25  $\mu\text{m}$  OPA, 45  $\mu\text{m}$  soft temper aluminum, 60  $\mu\text{m}$  PVC (product side)]. In their use the laminate is cold formed by mechanical pressure between the male and female dies.

**Lidding.** Whatever the forming process, the end result, partway down the machine, is that of a pocket containing product that needs sealing. In both cases the lidding material is roll fed and sealed by heat and pressure to the filled formed pocket in the substrate. The printed sealing layer may need to be very accurately placed (e.g., calendar packs).

There are two types of lidding; push through and “peel and push.” Lidding material may be of aluminum foil, paper, or plastic that is coated or laminated to enable sealing to the material of the blister pack.

**Strip Packs.** Usually two laminates of paper and/or soft temper aluminum and various plastics have been used as clear cellophane (i.e., coated rather than a laminate). This process uses two rolls of either laminate or film which at the point of coming together have the product (usually tablet or capsule) placed between the rolls and heat sealed inside the rolls by means of a hot knurled roller, thereby welding the inside layers of the laminate together. The essential point of this method is that the product itself helps to form the pocket. The number of packed tablets or capsules required is then cut off the strip.

**Sachets.** These are usually a laminate with aluminum as the center core. First the carrying pouch is formed, then dosed with product, then sealed so that contamination is reduced to a minimum.

There are two basic ways of using this form, fill seal process with laminates, films, or sheets in reel form.

1. Using two stock reels to form the two sides of the pouch (usually used in vertical form, fill, seal process).
2. Using only one stock reel of double the width but “centerfolding” it—the fold forming the base of the pouch (usually used in horizontal form, fill, seal process).

Both methods can be used for powders, granules, suppositories, liquids, pastes, creams, and loose items.

**Pillow Pack.** Today these are usually used for added protection as a secondary pack. In many respects they are similar to single-roll sachet packs, but the product forms the outline of the pillow pack, which is usually a heat fin—sealed up one edge and heat sealed/guillotined on each end.

**Ampules.** These are in many shapes and sizes, but have the common feature that they are always closed as soon as possible after filling by the use of gas/oxygen flames.

Glass (of whatever type) ampules may be designed in different ways.

1. Single ended
2. Double ended
3. Supplied with the end(s) open
4. Supplied with the end(s) closed



There are two ways of filling ampules.

1. Using a dip needle dispensing the correct amount of fluid
2. Using a tray and vacuum system, whereby the liquid is drawn into the open ampule by vacuum

The major problem with glass ampules is that when the glass is heated to its melting point for sealing there is some shedding of glass particles. This is in addition to the more frequently quoted source of glass spicules from the mechanical opening of the ampule. It is also difficult to fill any heat-sensitive product when the temperatures might be  $>1000^{\circ}\text{C}$  locally in the neck area.

## H. Closing the Package

All that needs to be said here is that the various methods of sealing listed below are critical to the whole of the integrity of the pack for three major reasons.

1. The closure is the weakest point in the pack design.
2. The pack will have to be opened and may need to be reclosed.
3. The closure may also have to act as a dispensing device in some designs.

There are two basic methods of closing the pack.

1. Integral sealing of the prime container needs the following conditions:
  - a. The seal area must be clean
  - b. Ampule closing with gas and oxygen
  - c. Heat sealing, noting the many factors involved
  - d. Impulse sealing
  - e. Cold sealing
2. Addition of individual closures
  - a. The mating surfaces should be clean
  - b. Roll on closures and ROPP
  - c. Screw closures of various types, noting the importance of the correct torque and thread compatibility
  - d. Snap-on closures, both snap-over and push-in types
  - e. Clinch closures
  - f. Spun closures
  - g. Swaged closures
  - h. Child-resistant closures
  - i. Tamper-evident/resistant systems

Where vibratory bowl feeds are used for the separation and feeding of closures it should be noted that the closures pick up dirt and static electricity unless the feeding system is properly controlled.

## I. Labeling or Identifying the Contents

### 1. Introduction

There are several different types of labeling to be considered. Broadly speaking the application can be divided into precoated, added adhesive, and shrink/stretch. There are many types of adhesives used, and the importance of adhesion to the security of decoration (identification) of the product cannot be overemphasized.

1. *Added adhesive.* Label with added wet glue or heat-sensitive glue.
2. *Preadhesed.* Gummed (activate with water), heat sensitive (includes such techniques as therimage and the sealing of preprinted foils and laminates), and pressure sensitive (probably the most popular system of all).
3. *Shrink or stretch sleeve* labels.

### 2. Plain Paper Plus Suitable Adhesive

*Moisture-Based Adhesives.* The thin film of moisture-diluted adhesive applied costs very little per 1000 labels, plus labor costs. Plain paper is most widely applied to glass, but can be applied to metal, particularly in the form of a complete wraparound label. Application can be by hand, semiautomatic, or fully automatic methods. Speeds of 1000 or more per min can be achieved.

Hand Application.

1. Brush and adhesive
2. Pasting out board
3. Craddy tray
4. Gluing machine

*Semiautomatic Labeling.* In this operation the machine selects, glues, and applies the label, but the item to which it is applied is placed into position by hand. Labels may be picked up by vacuum or the adhesive. The machine must be set up correctly, labels must be produced to certain critical limits, and the adhesive must be specially selected. A higher tack is necessary than that used for hand labeling. Speeds range from 25 to 60 per min (i.e., 3,600 per hr maximum).

*Fully Automatic.* The item is positioned and labeled automatically. This requires even more critical limits in terms of setting up, material, and adhesive tolerances. Change over time or adjustments also take longer. Speeds from 3,500 to 60,000 per hr are achieved.

### 3. Adhesives

The type of adhesive used depends *on the surface of the item to be labeled*. The adhesive must provide an adequate bond between the label and the container. Labeling of paper-based materials (unless specially treated) and glass usually

presents little difficulty. Labeling to plastic surfaces requires the use of specialized adhesives, which may be based on latex or synthetic resins (e.g., polyvinylacetate; PVA). In certain instances pretreatment of the plastic (in common with printing) with flaming or corona discharge or precoating will improve adhesion.

Dextrine is the most widely used adhesive, involving different levels of solid content. For instance, a low solid content is used for hand labeling since low tack (after initial placement it may be slid into position) and a slow setting time is necessary. For mechanical labeling, a high tack plus quick set is important. In addition, the adhesive must be nonthreading and nonfoaming. The addition of borax increases tack and setting speeds.

*Heat-Sensitive or Thermoplastic Adhesive-Based Labels Activated by Heat.* Two types are in use, instant tack and delayed tack. Both are based on synthetic resins. The former has to have heat and pressure applied to effect the transfer, but sets immediately after the source heat is removed.

1. *Instant tack adhesives.* These are usually used on high-speed automatic labeling machines, as the consistency of heat required to achieve adherence of the label effectively to the substrate (along with its cooling rate) is vital to the success of this method.

In many ways it resembles the wet glue applicator, but may have one of two different mechanisms of metering the adhesive.

- a. Roller wheels
- b. Hot melt glue gun

They may be applied by hand (hot plate), semiautomatically, or automatically. The machines involve far less cleaning time and generally get less "gummed up."

Instant tack labels find special usage on seals, pleated overwraps, and various header labels. They are not used for bottle or can labeling. Blister and strip packs are classified as part of this category, as we require the temperature of the lacquer to be raised high enough to obtain a permanent bond with the inner surface of the base material. Pressure needs to be applied as well, and usually there will be a knurling implanted onto the mating surfaces.

2. *Delayed tack adhesives.* These are usually heat activated to achieve the tacky state, after which they can be affixed to any item without a heat source. Most frequently the heating operation plus pressure of application are applied simultaneously, however. The tacky state remains for some time after the source of heat is removed. These are more versatile than the instant tack type, particularly in their application to bottles, tinplate, and plastics, either coated or laminated. Speeds of around 600 per min can be achieved.

Both of the heat-activated types are more costly than conventional paper-adhesive labeling. Selected advantages may offset the cost increase; for example

1. Virtually no cleaning down, no wastage of adhesive
2. Quicker setting-up time
3. Adhesion to a wider range of surfaces
4. Less affected by powder contamination or varying ambient atmospheric conditions (temperature and humidity)
5. A high standard of cleanliness, no labor for wiping down

*Self-Adhesive or Pressure-Sensitive Labels.* It is preferable to call these *pressure-sensitive* labels, as both the pregummed and heat-sensitive labels are self-adhesive (i.e., the adhesive is already there). They consist of a suitable label facing material (usually paper or polymer), the reverse side of which is coated with a permanently tacky adhesive that is in contact with a backing paper (occasionally plastic) that protects it prior to use. The backing paper is coated with a special release coating that permits the label to be removed easily. Labels may be provided on roll or sheet form; both can have the label “laid on”; that is, the unprinted area has been cut and removed.

Pressure-sensitive labels can be applied to most materials (wood, plastic, metal, glass, paper, and board). As the adhesives are resin-based (plasticized thermoplastics), migration problems can occur when they are applied to certain plastics (e.g., PVC, LDPE).

Labeling can be carried out by hand, semiautomatically, or fully automatically. In all instances accurate positioning is essential, as the label cannot be slid into position. Machine speeds of 800 per min are attainable.

Roll-fed labels offer one massive advantage in *security*—they dramatically reduce the risk of admixture.

#### 4. Stretch and Shrink Plastic Labels

Most stretch and shrink labels are added to containers in a tubular form, generally relying on the stretch/shrink tightness of the material to retain label position for the life of the product. An additional feature is that the label may be extended over the closure to form a tamper-evident seal on suitable packs.

*Stretch labels* are unusual in pharmaceutical packaging, but have the advantage of *not* requiring heat or specialized artwork to achieve a professional finish. They are difficult to use successfully on anything but regular shapes, however.

*Shrink labels.* As indicated above, a heat shrink tunnel is needed (check the temperature stability of the formulation), and as the tube is fed loosely over the container and tightened there is the potential for distortion of the print. This is compensated for by distorting the artwork so that the finished shrunk sleeve copy is visually correct.

The materials used are generally LDPE, LLDPE, PP, OPP, or PVC in thicknesses ranging from about 30  $\mu\text{m}$  to about 100  $\mu\text{m}$ .

## **J. Leaflet-Insertion Techniques**

### **1. Added Loose**

The leaflet is placed in its container, usually the secondary packaging or folding carton, in such a way that there is the greatest chance of the patient having to remove the leaflet to get at the product in the hope that he or she will read the carefully compiled information contained therein.

*Manual.* Here a prefolded leaflet is taken and placed in a manually erected carton with the product being added at the same time.

*Semiautomatic.* Again usually a prefolded leaflet is placed manually in an automatically erected carton already containing the product.

*Automatic.* This can take prefolded, sheet-fed, or roll-fed leaflets and present them to be pushed into the carton by the product. In comparison to manual and semiautomatic operation, automatic equipment is very sensitive to paper porosity, physical size, paper calliper, fold design and accuracy, flying leaves, and so on, and has difficulty with two different size leaflets.

### **2. Attached to the Container or Product**

There are two basic types that can be attached to the container or product itself.

1. The integral label/leaflet, which is a prefolded leaflet attached to the front of a pressure-sensitive label, and for all practical purposes can be treated as a label.
2. The “outsert.” This is an American idea in which the leaflet is folded down to the height of the container and is held against the side of the container by either a stretch or shrink band or has its flying leaf sealed together and stuck with a heat-fix adhesive or is cellotaped to the container. None of these fixings is allowed to obscure the prime label.

## **K. Folding or Collapsible Cartons**

### **1. Introduction**

Cartons contain, protect, and distinguish the product from all others in an economical manner. They are commonly used as “secondary” packaging. There is a general order of quality of the boards used.

- Paperboard
- Brown lined paperboard
- Kraft lined paperboard
- Cream or white lined paperboard

White lined manilla (triplex); white lined folding boxboard—unbleached body with bleached liner(s)  
Coated boards and boards based on pure pulps (e.g., cast coated and foil lined)

## 2. Stages in Carton Manufacture

The manufacture of a folding carton requires a number of stages, as described below.

*Choice of Design.* This must take into account:

Style  
Type of board  
Layout  
Size  
Graphics  
Quantity to be produced  
Method of printing

Some knowledge is required on how these can influence the material performance during packaging on the line and thus the specification of the cartoning machines.

*Prefolding and Gluing.* Cartons are usually supplied in a collapsed state, with a glued side seam and two of the folds already made. Following gluing, the carton is usually compressed toward a flat state, where it already exhibits a form of “crease set.” To minimize this it is frequently advisable to open the carton through 90–180°C momentarily to literally break the crease set and generally assist final erection on the cartoning machine. This process is known as “prefolding.”

*Hand Cartoning.* Basically any carton style, with any form of good, any calliper board, any of the closure flap design (lock slit, friction fit, claw lock, crash lock, envelope lock), any number of leaflets, measures, or droppers, and so forth can be used in hand cartoning.

*Semiautomatic.* This is usually a machine in which the carton is erected, the bottom is closed, and the gaping top is presented to the operator who drops in the required goods and accessories. It would be expected that this type of machine would have a form of overprinting unit of some type built into the cartoning machine.

*Automatic.* There are two basic types of machines—intermittent motion and continuous motion. The intermittent is smaller, slower, and cheaper, usually with a blade-opening action for the carton prebreak so that it is likely to accept

a lower quality of carton than the high-speed machines. The continuous-motion machines tend to be much larger, faster, and more expensive, and with a vacuum pickup of the carton for a “knock” prebreak are much more sensitive to the quality of the cartons presented to it.

Automatic cartoning should only be used when the quantity per batch, lot, or order is large enough to keep the machine running for more than it is down on changeover. Speeds range from 60 to 650 per min, with machine prices rising to match the speed. The design of closure flaps is probably practically limited to lock slit, friction fit, and glued flaps. This again is in the interest of speed.

### 3. Collation

Overwrapping, stretch-wrapping, or shrink-wrapping materials may be used on single items or bundles of 5, 6, 10, 12, 20, 24, or 25, depending upon the marketing preference.

## L. Online Testing

What is it sensible to test on a packaging line? Present-day technology may be able to test many parameters, so how do companies choose which parameters they are going to test? It is assumed that the incoming packaging materials have been supplied to an adequate authorized specification and quality controlled in an approved manner so that the materials arriving at the packaging line are known to be within the parameters of the specification. It therefore follows that the testing that follows is that associated with putting the elements of the pack together. There are some testing procedures that are essential to the correct functioning of the line, such as those that detect that the pack is incomplete.

- No container (or film), no fill
- No container, no ullage filler, no closure
- No container, no label
- No container, no carton
- No leaflet, no carton

All this means is that if any part of the total pack structure does not feed to the line, the feeding mechanisms for the subsequent operations will not be activated. It is also essential to ensure that the *correct* fill of product has gone into the primary pack by whatever method is used.

- Check weigh of either gross weight, or better tare each primary pack and check weigh with a shift register tracking each individual primary pack
- Level detection by means of light, x-ray, alpha radiation, etc.
- Fill of blisters by some means of optical/electronic scanning or feeler microswitch

Fill of roll wraps by length  
Fill of strip packs by feeler microswitch

Another essential area is the testing of the seal integrity of the closure.

Level/tilt/position of applied closure  
Inert gas “sniffing” of form, fill and seal packs

A fourth area considered essential for checking is that of ensuring that the correct identification is on the primary pack.

Bar code reading or optical character verification (OCV) of the label/  
prime identification source material  
Bar code or OCV reading of leaflet  
Bar code or OCV reading of carton  
Bar code or OCV reading of outer casing/outer label

The techniques of optical character manipulation have been used for over 15 years, but have only become economically compatible with bar code reading in the last 5 years.

## **M. Operators and Training**

There must be planned routine maintenance, changeovers planning with the engineers, planners, and marketing, in particular in order to maximize the economic order quantity (EOQ). The EOQ is defined as the point at which the cost of changeover equals the cost of holding the extra inventory by increasing production order quantities.

They should also have been trained on the particular machines that are on the packaging line, particularly in safety and observation, and have a thorough knowledge of how the marketable pack should look at all stages of its packaging. There should be codes of dress, discipline, line cleandown procedures, and other operating procedures in which the operators have been trained. These should also be readily available nearby so that they may be referred to at any time.



# 18

## Analysis of Retrospective Production Data Using Quality Control Charts

**Peter H. Cheng**

*New York State Research Foundation for Mental Hygiene, New York,  
New York, U.S.A.*

**John E. Dutt**

*EM Industries, Inc., Hawthorne, New York, U.S.A.*

### I. INTRODUCTION

In industry, because of in-house demands and GMP requirements, the acquisition and subsequent retention of in-process and final-product data are necessary. For example, before releasing a product, many pertinent tests are performed on product batches to ensure that active ingredients and essential product attributes meet desired specifications. Data from such pertinent tests, accumulated over time, are often called historical, or retrospective, data.

In this chapter, several types of control charts for the analysis of historical data are discussed. Explanations of the use of  $\bar{x}$  and  $\bar{R}$  charts, for both two or more measurements per batch and only one measurement per batch, are given, along with explanations of modified control charts and cusum charts. Starting with a brief exposition on the calculation of simple statistics, the construction and graphic analysis of  $\bar{x}$  and  $\bar{R}$  charts are demonstrated. The concepts of “under control” and “out of control,” as well as their relationship to test specifications, are included. The chapter concludes with consideration of the question of robustness of  $\bar{x}$  and  $\bar{R}$  charts.

Much of the discussion here stems from experience with quality control charts in the pharmaceutical industry. For the use of quality control charts in other industries, the following requirement established by the Nuclear Regulatory Commission [1] may be useful.

The licensee shall establish and maintain a statistical control system including control charts and formal statistical procedures, designed to monitor the quality of each type of program measurement. Control chart limits shall be established to be equivalent to levels of (statistical) significance of 0.05 and 0.001. Whenever control data exceed the 0.05 control limits, the licensee shall investigate the condition and take corrective action in a timely manner. The results of these investigations and actions shall be recorded. Whenever the control data exceed the 0.001 control limits, the measurement system which generated the data shall not be used for control purposes until the deficiency has been brought into control at the 0.05 level.

## II. SIMPLE STATISTICS

Consider the following example in which a batch of drug D has been assayed four times, with the following potencies reported: 46.2, 44.4, 44.9, and 43.8. An *estimate of the overall potency* is obtained by calculating the *mean*, or *average*, of these four values. Using the notation  $\bar{x}$  for the mean,  $\bar{x} = 44.825$ . The value  $\bar{x}$  is an estimate of the batch's true potency, which is symbolized by  $\mu$ .

The *range* and *standard deviation* are two simple statistics for expressing the amount of variability or "scatter" of the four potencies. The range is easier to compute because it is the difference between the maximum and minimum values. Using  $\bar{R}$  for the range,  $\bar{R} = 46.2 - 43.8 = 2.4$ . The standard deviation, symbolized by  $s$ , is not as easy to compute, and its formula is presented later. For the four potency values,  $s = 1.021$ . The value  $s$  is an *estimate of variability*, of the assay-measuring process. The *true standard deviation* is noted by  $\sigma$ .

These computations give an estimate of the batch's potency and indicate the variability of data within a batch. A complete analysis consists of computing the estimated potencies of all batches, as well as the variability of the batches' data values.

Because there are not always four measurements per batch, the following notation is presented to facilitate the generalization to any number of assays per batch:

$n$  = total number of data (assay) values per batch

$x_i$  =  $i$ th data value, where  $i$  ranges from 1 to  $n$

$\Sigma x_i = (x_1 + \dots + x_n)$  = sum of all data values

$x_{\max}$  = largest data value

$x_{\min}$  = smallest data value

With this notation, the simple statistics take the form

$$\text{Mean } \bar{x} = \frac{\sum x_i}{n}$$

$$\text{Range } R = x_{\max} - x_{\min}$$

$$\begin{aligned} \text{Standard deviation } s &= \sqrt{\frac{\sum (x_i - \bar{x})^2}{(n - 1)}} \\ &= \sqrt{\frac{\{(\sum x_i^2) - n(\bar{x})^2\}}{(n - 1)}} \end{aligned}$$

The second expression for the standard deviation is usually computationally easier. The term  $\sum x_i^2$  is calculated by squaring each data value and then summing all the values up to  $n$ .

Initially it will be assumed that the *variation of the measurement* around the true batch potency follows a normal distribution. This assumption means that if the same batch were repeatedly assayed, the data values would be distributed in a symmetric bell-shaped curve as in Fig. 5A. Most values would be clustered near the center (true potency), with some extreme values lying farther away. In theory, 68.2% of the data values would be found between  $\mu - \sigma$  and  $\mu + \sigma$ , 95.4% of the values would be between  $\mu - 2\sigma$  and  $\mu + 2\sigma$ , and 99.7% of the values would be within the range  $\mu - 3\sigma$  to  $\mu + 3\sigma$ .

For example, suppose a batch was known to have a true potency  $\mu = 101$  and that the assay has a variability expressed as  $\sigma = 2$ . Then 68.2% of the future assay values would be expected between  $101 - 2 = 99$  and  $101 + 2 = 103$ , 95.4% of the values would be between 97 and 105, and 99.7% of the values would be between 95 and 107.

Figure 1 taken from the petroleum industry shows a quality control chart where the data in the frequency histogram is normally distributed. In this particular control chart, the grand average is 7.08 and is surrounded by  $\pm 1, 2, 3$  standard deviations rather than range values.

### III. QUALITY CONTROL (QC) CHARTS

#### A. $\bar{x}$ and $R$ Charts (For at Least Two Measurements Per Batch)

##### 1. Construction (For at Least Two Measurements Per Batch) [2–4]

It is reasonable to assume that at least 20 batches are available in a retrospective study. Suppose at least two measurements were obtained from each batch. In terms of the previous notation, assume  $n$  is greater than or equal to 2.

# CONTROL - PERFORMANCE CHART

LUBRICANT ADDITIVE

PERIOD COVERED

4/4/90 - 8/30/90

$\bar{x} = 7.08$

$\sigma = 0.114$

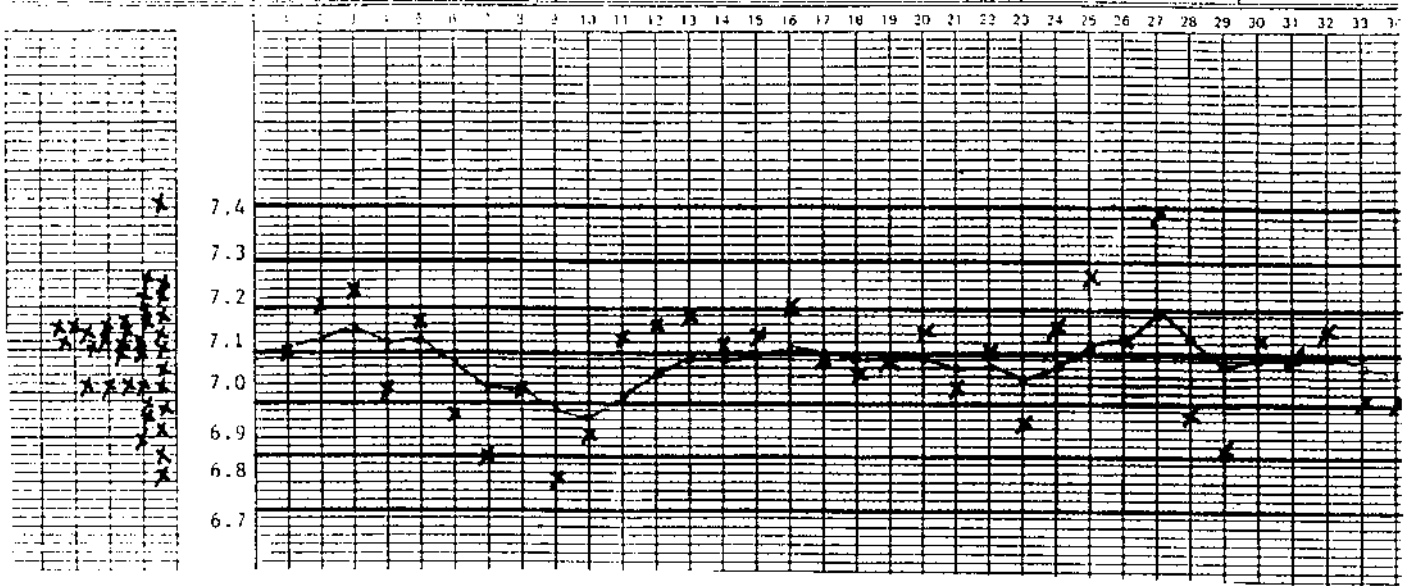


Figure 1 Control/performance chart for the sulfated ash test on a gasoline additive.

1. For each batch, calculate the mean  $\bar{x}$  and range  $\bar{R}$ . Sometimes for historical data, only the mean, high, and low values are recorded.
2. Construct two graphs. In the first graph, plot the batch means versus batch number or any other similar ordering variable denoting time, such as week or month. In the second graph, plot the batch ranges versus the same batch number of other similar variable used for the first graph.
3. Calculate  $\bar{\bar{x}}$ , which is the average of all the batch means, and  $\bar{\bar{R}}$ , which is the average of all the ranges. Draw a solid horizontal line for  $\bar{\bar{x}}$  on the  $\bar{x}$  graph, and do the same for  $\bar{\bar{R}}$  on the  $R$  graph.
4. Calculate the control limits as follows:

	$\bar{x}$ chart	$R$ chart
UCL (upper control limit)	$\bar{\bar{x}} + A_2\bar{\bar{R}}$	$D_4\bar{\bar{R}}$
LCL (lower control limit)	$\bar{\bar{x}} - A_2\bar{\bar{R}}$	$D_3\bar{\bar{R}}$

Values of  $A_2$ ,  $D_3$ , and  $D_4$  for different values of  $n$ , the number of measurements per batch, are given below:

$n$	$A_2$	$D_3$	$D_4$	$n$	$A_2$	$D_3$	$D_4$
2	1.880	0	3.267	7	0.419	0.076	1.924
3	1.023	0	2.575	8	0.373	0.136	1.864
4	0.729	0	2.282	9	0.337	0.184	1.816
5	0.577	0	2.115	10	0.308	0.228	1.777
6	0.483	0	2.004				

For  $n > 10$ ,  $A_2$ ,  $D_3$ , and  $D_4$  can be found in standard texts, for example, Ref. [2].

5. Draw dotted horizontal lines for the UCL and LCL on  $\bar{x}$  and  $R$  charts, respectively.

Example: Suppose there are 50 batches of retrospective data, with two potency values recorded for each batch. How would the  $\bar{x}$  and  $R$  charts be constructed?

First, calculate mean  $\bar{x}$  and range  $R$  for each batch. Because there are two values per batch, the range is the difference between each pair of values, with a positive sign in front of each difference.

These calculations give 50  $\bar{x}$  values and 50  $R$  values. The averages of each set of these values form  $\bar{\bar{x}}$  and  $\bar{\bar{R}}$ , respectively. Suppose  $\bar{\bar{x}} = 105$  and  $\bar{\bar{R}} = 2$ . Plot the 50 calculated  $\bar{x}$ 's and  $R$ 's on two different graphs, and draw the horizontal lines for  $\bar{\bar{x}} = 105$  and  $\bar{\bar{R}} = 2$ . With  $n = 2$ ,  $A_2 = 1.88$ ,  $D_3 = 0$ , and  $D_4 = 3.267$ , the control limits for the  $\bar{x}$  chart are:

$$\text{UCL} = 105 + (1.880)2 = 108.76$$

$$\text{LCL} = 105 - (1.880)2 = 101.24$$

Similarly, limits for the  $R$  chart are:

$$\text{UCL} - (3.267)2 = 6.334$$

$$\text{LCL} = (0)2 = 0$$

These control limits are particularly useful to identify any points that exceed the limits.

## 2. Discussion

When control charts are employed for process control, two sets of control limits are frequently used:  $\bar{\bar{x}} \pm A_2\bar{\bar{R}}$  (action limits) and  $\bar{\bar{x}}T \pm 2/3 A_2\bar{\bar{R}}$  (warning limits). When the process exceeds the action limits, corrective steps are necessary. When the process exceeds only the warning limits, the user is alerted that the process may be malfunctioning.

The results of the construction of the  $\bar{x}$  and  $R$  charts may resemble the top two graphs in Figs. 2–6. The points in Fig. 2 show little evidence of trends (i.e., a rising, falling, and rising distribution of points). In such a situation, the process is said to be *in control*.

Some indicators that a process has not been in control in the past are:

1. Two or more consecutive points on the  $\bar{x}$  or  $R$  charts fall outside control limits.
2. Eight or more consecutive points on the  $\bar{x}$  or  $R$  charts fall on the same side of the central line, even if none of the points exceed the control limits.
3. When the batch mean exceeds its control limits, but its corresponding range does not exceed its limits, this suggests the process may be operating on a new mean level or the level of the process has shifted.

In contrast, when the batch mean is within its control limits, sometimes operator carelessness or local disturbances not related to the machine setting or process may be the cause. A cluster of  $\bar{x}$  or  $R$  values outside the control limits has real significance, because it indicates a pervasive influence.

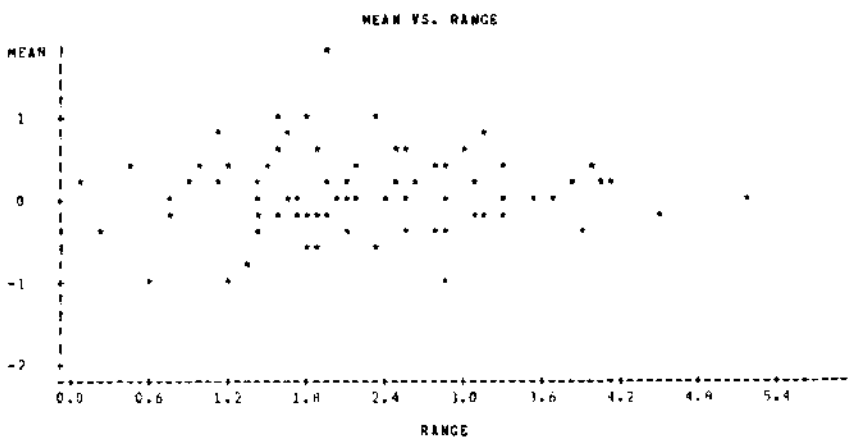
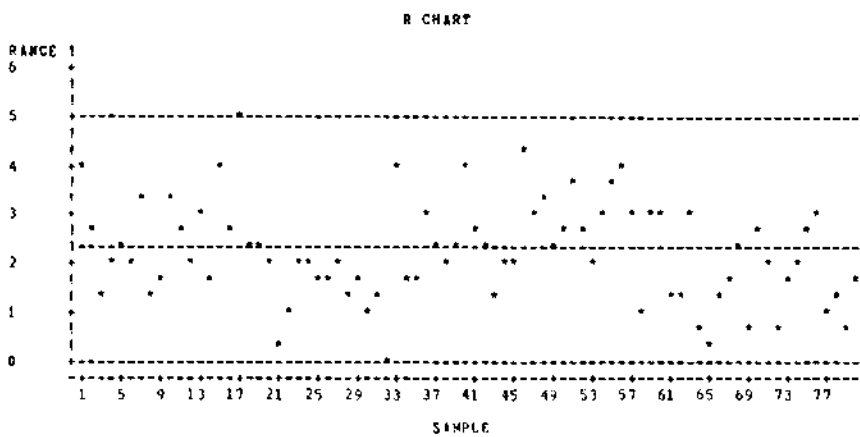
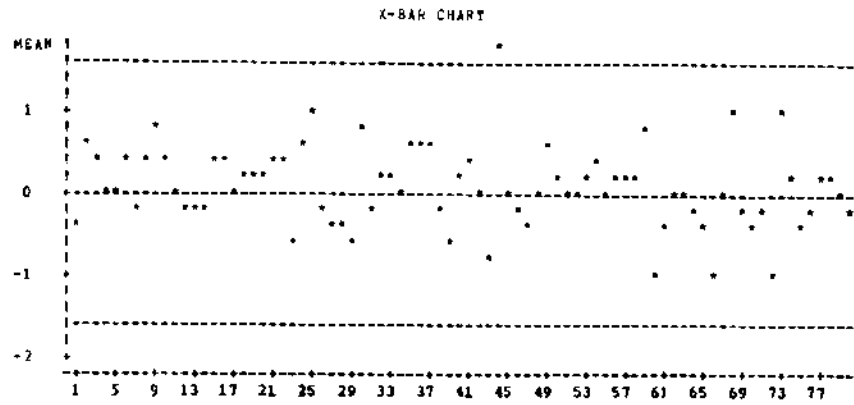
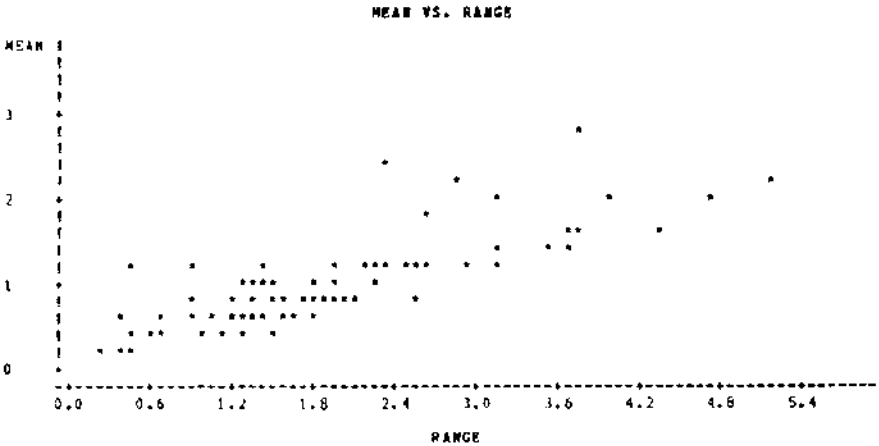
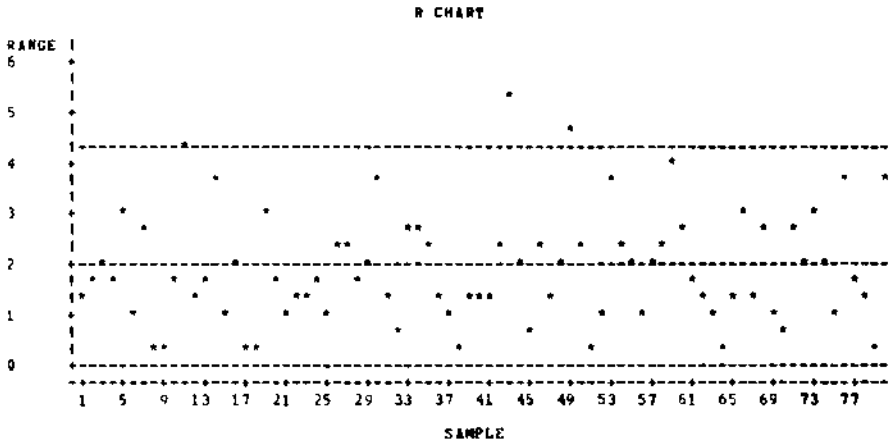
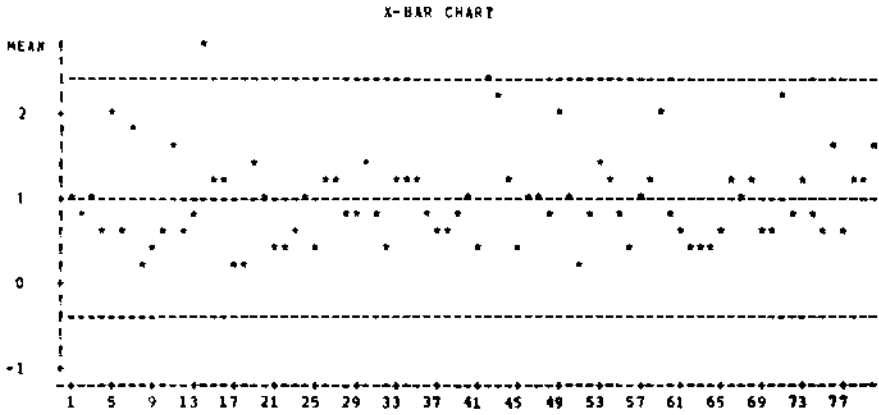
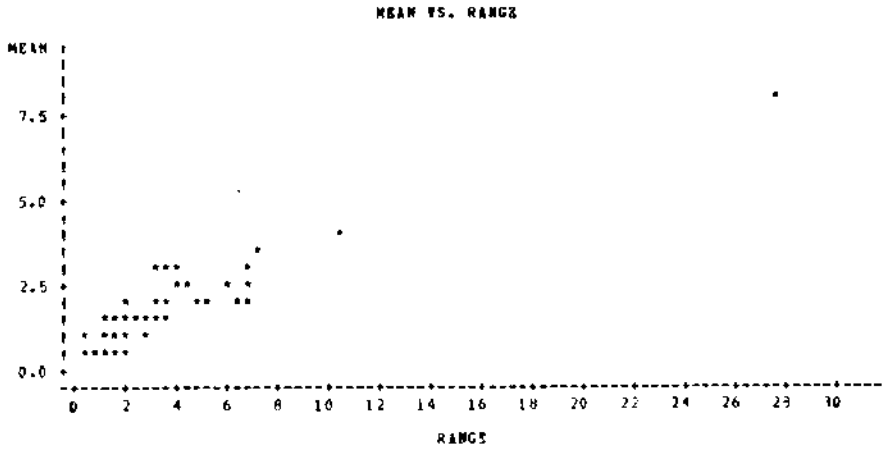
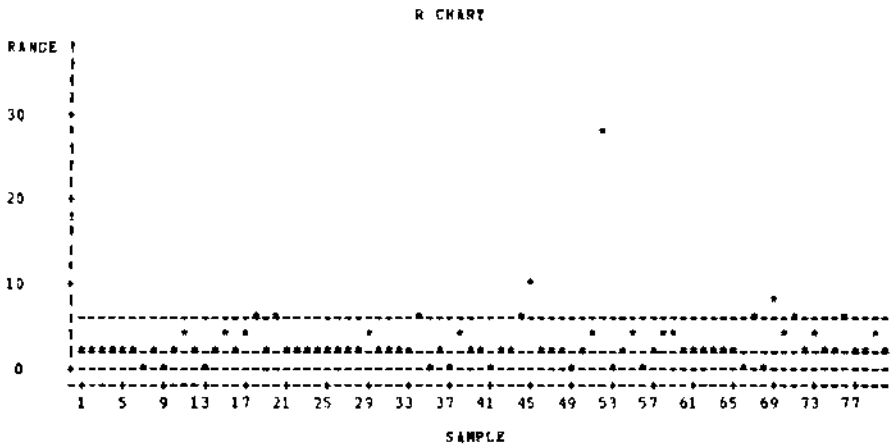
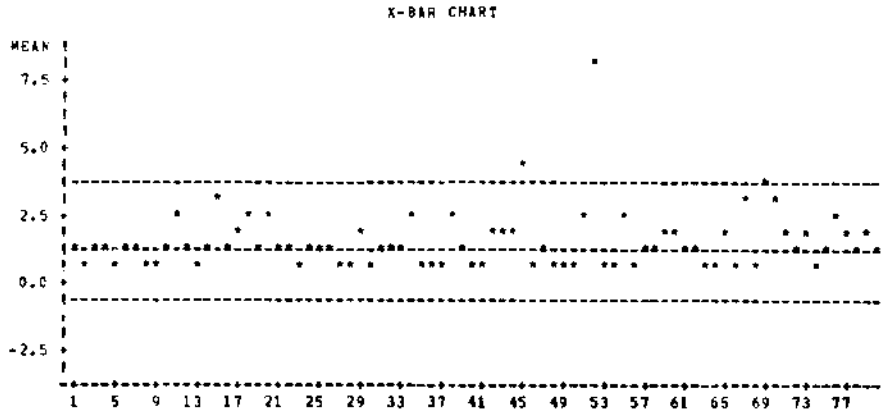


Figure 2 Normal distribution.

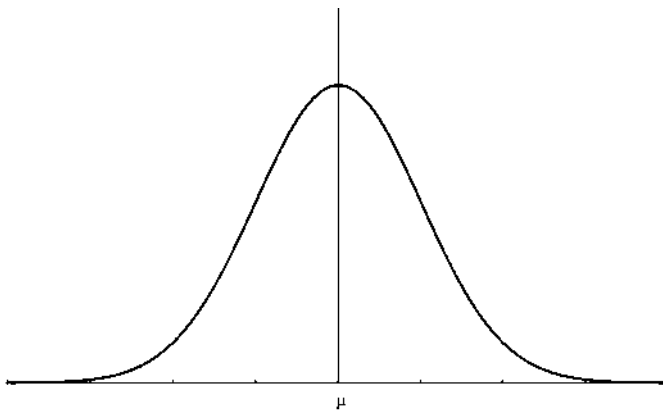


**Figure 3** Exponential distribution.

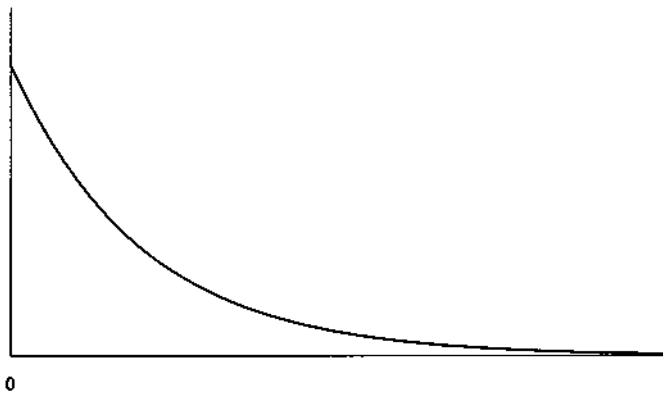




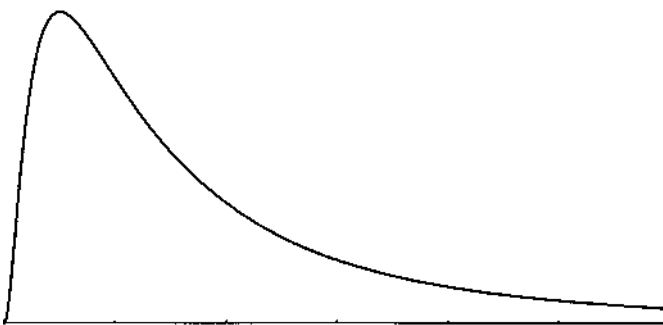
**Figure 4** Lognormal distribution.



(A) Normal Distribution

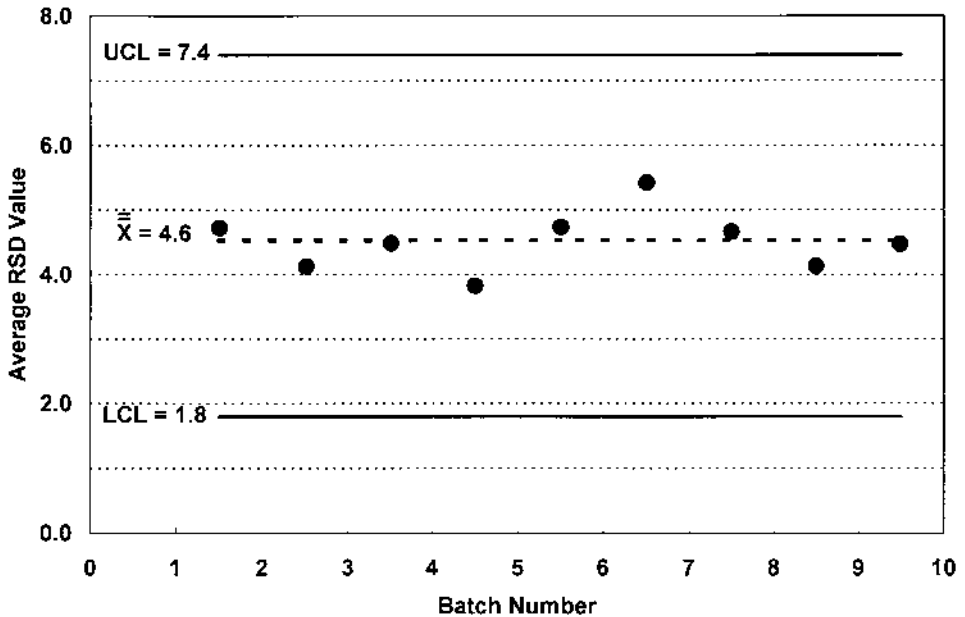


(B) Exponential Distribution



(C) Lognormal Distribution

**Figure 5** (A) Normal distribution (mean =  $\mu$ , std. dev. =  $\sigma$ ). (B) Exponential distribution. (C) Lognormal distribution.



**Figure 6** Residual standard deviation (RSD) quality control chart.

It is not uncommon for a product batch to be assayed at several stages in processing (e.g., as raw material after mixing, after drying, and as finished product). If the retrospective data exist, then control charts should be set up for each stage, using batch number as the horizontal variable on the  $\bar{x}$  and  $R$  charts. Matching the different stage charts with the common batch numbers affords the opportunity to examine how well the process is in control at each stage. If each stage is judged to be in control, it is reasonable to conclude that the entire process is in control. If, however, some stages are not in control while others are, questions about the validity of the process are raised.

When specifications are set for individual testing results, it is misleading and meaningless to plot them on  $\bar{x}$  charts. However, when specifications are set for the sample average  $\bar{x}$ , or when individual specifications and control charts for one measurement per batch are used, it is advantageous to include them on the  $\bar{x}$  chart. In fact, whether under control or not, a process can either meet the specifications or not. Below are the four possible actions to be taken in each of the four situations.

- a. Process in control and specifications met.
  - i. No change is required.
  - ii. Skip-lot (batch) test can be instituted.
- b. Process in control but specifications failed.
  - i. 100% inspection.
  - ii. Fundamental change in the production process.
  - iii. Change specifications.
- c. Process out of control but specifications met. Investigate the process to identify and remove assignable causes for out-of-control occasions.
- d. Process out of control and specifications failed. Similar to item c, but prompt investigation is mandatory.

In the analysis of retrospective data, the use of  $\bar{x}$  and  $R$  charts has advantages and disadvantages. If no data points exceed the  $\bar{x}$  or  $R$  control limits, then it is reasonable to say the process has been in control and that the standard operating procedures are fulfilling their functions. While not explicitly discussed here, data obtained from new batches can be plotted on new  $\bar{x}$  and  $R$  charts using the same control limits. This new plotted data can help to warn the operator when the process is close to being or is out of control.

If control limits were exceeded in the past, however, corrective action now can hardly be taken. If control limits were frequently exceeded, it may be worthwhile to institute a search for an assignable cause, or causes. The necessary data may not exist, or no reasonable cause may be found. In such cases, maintaining control charts for new batches will probably be more effective in identifying perturbing influences on the process.

## B. $\bar{x}$ and $R$ Charts (For One Measurement Per Batch)

### 1. Frequently Only One Record Per Batch is Available

While a range for any batch cannot be computed, the control limits for the  $\bar{x}$  chart depend on finding  $\bar{R}$ . The procedure for constructing  $\bar{x}$  and  $R$  charts needs to be modified and is described below in stepwise fashion, using an example.

1. Suppose 30 batch values are recorded, one potency result per batch. Let these values be written as  $x_1, x_2, \dots, x_{30}$ . The mean for each batch is simply  $\bar{x} = (\sum x_i)/30$ .
2. Form the values  $x_2 - x_1, x_3 - x_2, \dots, x_{30} - x_{29}$ , and take the absolute value of each difference.
3. Calculate the mean of these 29 values and call the result  $\overline{MR}$  (for moving range).
4. Calculate the control limits as follows:

	$\bar{x}$ chart	$R$ chart
UCL	$\bar{\bar{x}} + 1.88\overline{MR}$	$3.267\overline{MR}$
LCL	$\bar{\bar{x}} - 1.88\overline{MR}$	0

Using  $n = 2$ , the values of  $A_2 = 1.88$ ,  $D_3 = 0$ , and  $D_4 = 3.267$ , are taken from the table under item d in Section I.

### C. Modified Charts

Here is discussed the situation in which the  $R$  chart shows that the within batch variation is under control, but the  $\bar{x}$  chart suggests the between-batch variation is out of control. When the specifications are wide, a modified control chart can be employed. Example: In the following, each batch has two determinations. The upper specification for an individual determination is 15 mg/g. (Lower specification can be considered similarly.)

Batch	Determinations		Mean	Range
	1	2		
1	7.3	7.3	7.2	0.2
2	9.7	9.5	9.6	0.2
3	3.2	3.0	3.1	0.2
4	10.2	10.4	10.3	0.2
5	5.3	5.1	5.2	0.2
Average			7.08	0.2

The upper control limits would be  $7.08 \pm A_2(0.2) = 7.08 + (1.88)(0.2) = 7.46$ . Concerns over batches 2 and 4 arise naturally. The modified control chart calls for the use of  $15 - (\sqrt{2} - 1)(1.88)(0.2) = 14.2$  as the UCL and thus eliminates the questions over batches 2 and 4. In the application of process validations, these situations are frequently encountered, and modified control charts enable us to claim the validation of the process.

### D. Cusum Charts

A cumulative sum (or cusum) chart is a type of control chart that can detect changes in process average more powerfully than an  $\bar{x}$  chart. A reference value  $K$  is chosen.  $K$  can be the process target value, historical average, or any convenient value. As new values  $x_1, \dots, x_n$  are observed, the cumulative sums

$$S_\tau = \sum_{i=1}^{\tau} (x_i - K)$$

are calculated and plotted sequentially. Note  $S_1 = x_1 - K$ ,  $S_2 = x_1 + x_2 - 2K$ ,  $S_3 = x_1 + x_2 + x_3 - 3K$ , etc. The important characteristic of cusum charts is the slope of the cumulative sums  $S_\tau$ . If the process is at some level  $\mu$  which is larger than  $K$ , each new cumulative sum will be  $\mu - K$  units larger than the previous sum (except for random variation). The cusum chart will show a steadily increasing sequence of sums.

If the process shifts to a new mean  $\mu^*$  which is less than  $\mu$ , and sums will tend to decrease promptly. The slope will change, and this change in slope informs the user that the process level has changed.

Example: [Table 1](#) gives an example of using a cusum chart for manufacturing data. The slope of cumulative sums changes for the sums formed from batch 103, suggesting that the process operated at a lower mean level.

#### IV. ROBUSTNESS OF $\bar{x}$ AND $R$ CHARTS

The factors  $A_2$ ,  $D_3$ , and  $D_4$  used in the construction of  $\bar{x}$  and  $R$  charts were derived from the assumption that all the retrospective data follow a normal distribution. However, random variation occurs in other nonsymmetrical forms. The term *robustness* refers to the extent to which the charts are still useful when the random variation of retrospective data is not normal.

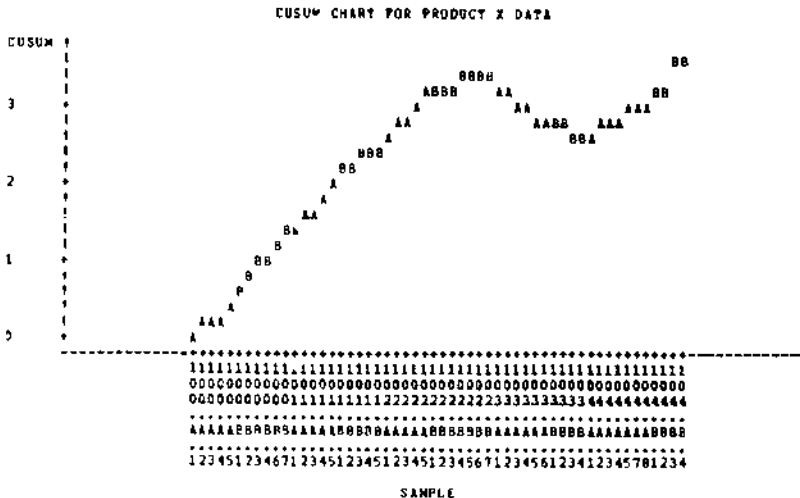
For comparison, three types of random variations, following distribution forms of normal, exponential and log-normal, are presented in [Figs. 5A–C](#), respectively. It is not as important to know the algebraic forms of these curves as it is to appreciate the distinct differences among them in appearance.

So, what happens if the random variation of the retrospective data is not normal, but has some other distributional form? Are  $\bar{x}$  and  $R$  charts useful in such a situation? The  $\bar{x}$  chart is probably useful, but the  $R$  chart is not.

1.  $\bar{x}$  charts. Even if the number of measurements per batch is as small as four and the random variation is not normally distributed, the distribution of the mean of the four will be reasonably normal, so  $\bar{x}$  charts would still be meaningful. Shewhart demonstrated this with distribution of means of 1000 simulated “batches” of four observations each. The true random densities were uniform (rectangular) and triangular, but the distribution of the average of four nearly follow the normal curve.
2.  $R$  charts. Many published studies [5–7] show that for small sample sizes per batch the factors  $D_3$  and  $D_4$  used in setting control limits are

**Table 1** Product X Data (Target K = 11.971)

PRODUCT X DATA -- TARGET K = 11.971					
BATCH	PART	SAMPLE	MEAN	MEAN_K	CUSUM
100	A	1	11.9915	0.02050	0.02050
		2	12.1317	0.16075	0.18125
		3	11.9759	0.00487	0.18612
		4	12.0368	0.06580	0.25192
		5	12.1227	0.15175	0.40167
	B	1	12.1320	0.16100	0.56467
		2	12.1742	0.20325	0.76792
101	A	3	12.1537	0.18270	0.95062
		4	12.1114	0.14037	1.09100
		6	12.0647	0.09375	1.18475
		7	12.1345	0.16350	1.34825
		1	12.1029	0.13187	1.48012
	B	2	12.0712	0.10025	1.58037
		3	12.0901	0.11912	1.69950
102	A	4	12.1441	0.17312	1.87262
		5	12.1087	0.13775	2.01037
		7	12.0970	0.12600	2.13637
		2	12.0891	0.11812	2.25450
		3	12.0694	0.09837	2.35287
	B	4	11.9731	0.00212	2.35500
		5	12.1049	0.13387	2.48887
103	A	1	12.0490	0.07800	2.56687
		2	12.1279	0.15687	2.72375
		3	12.0687	0.09770	2.82145
		4	12.1486	0.16962	2.99187
		5	12.1351	0.16412	3.15520
	B	1	11.9925	0.02150	3.17670
		2	12.0614	0.09037	3.26747
104	A	3	11.9881	0.01712	3.28420
		4	12.0017	0.03075	3.31495
		5	12.0285	0.05750	3.37245
		6	12.0214	0.05037	3.42282
		7	12.0025	0.03150	3.45432
	B	1	11.6545	-0.31650	3.13782
		2	11.9680	-0.09300	3.13482
105	A	3	11.7564	-0.21463	2.92020
		4	11.9781	0.00712	2.92732
		5	11.9026	-0.06838	2.85895
		6	11.9307	-0.04025	2.81870
		1	11.9219	-0.04913	2.76957
	B	2	11.9401	-0.02280	2.74657
		3	11.9085	-0.06250	2.68420
106	A	4	11.9047	-0.06625	2.61795
		1	12.0265	0.05550	2.67345
		2	12.0207	0.04975	2.72320
		3	12.0357	0.06475	2.78795
		4	12.0337	0.06275	2.85070
	B	5	12.0397	0.06875	2.91445
		7	12.0146	0.04362	2.96307
107	B	8	12.0762	0.10525	3.06832
		1	12.0726	0.10162	3.16995
		2	12.0781	0.10712	3.27707
		3	12.2047	0.23375	3.51882
4	12.0022	0.03125	3.54207		



not much changed for nonnormal random variation. For large sample sizes, the calculated control limits are no longer reliable for nonnormal random variation, therefore, one should be cautious about  $R$  charts based on large sample sizes, unless it is known that the random variation is normally distributed. Unfortunately, one seldom knows that the true distribution is normal.

As an example, 80 “batches” with four observations per “batch” were each simulated for the following random variation forms: normal, exponential, and lognormal, (see Fig. 5 A–C).  $\bar{x}$  and  $R$  charts were constructed for each set as if the true random variation were normal. The charts appear in Figs. 2–4. The results appear in Table 2. This table shows that roughly the same number of points falls outside the  $\bar{x}$  control limits, regardless of the form of the random variation. However, the lognormal distribution has many more  $R$  values outside the control limits than the other four distributions. The operator of the process would mistakenly think this process was frequently out of control. The  $R$  chart shows greater susceptibility to nonnormality in the random error structure.

Figures 2–4 also illustrate a method for checking the assumption of random errors forming a normal distribution.  $\bar{x}$  is plotted versus  $R$  at the bottom of each figure. These graphs show different forms for the different distributions. Most of the points from the normal, uniform, and double exponential distributions form an essentially horizontal elliptical shape. For the exponential and lognormal distributions, the points form tilted elongated ellipses because of the heavy “tails” in these distributions. If a plot of  $\bar{x}$  versus  $R$  shows a tilted elliptical shape, then the assumption of normality is not reasonable. Horizontal elliptical shapes do not prove normality, but they do suggest the random errors are equally likely to be positive or negative. In such cases, probably little harm will be done in using the assumption of normality. More details are in Appendix I. These figures need a large number of historical batch records but can be very useful when the records contain mean, high, or low only.

**Table 2** Number of Points Outside Control Limits

	Normal	Uniform	Exponential	Lognormal	Double exponential
$\bar{x}$ chart	1	1	2	3	0
$R$ chart	1	0	3	10	3



## APPENDIX I. DISCUSSIONS RELATED TO TABLE 1 AND THE $\bar{x}$ VS. $R$ PLOT IN FIGS. 2–4

1. Normal distribution,  $N(0, 1)$ , with density function  $\phi(x) = \exp(-x^2/2)/\sqrt{2\pi}$ .
  - a. Sample mean  $\bar{x}$  and range  $R$  are independently distributed, statistically (see Fig. 3).
  - b.  $E(R) = d_2 = 2.059$  as in [6].
2. Exponential distribution with density  $e^{-x}$  for  $x \geq 0$ .
  - a.  $ER = \sum_{k=1}^{n-1} 1/k$ .
  - b. The simple inequality  $\bar{x} \geq R/n$  gives the lower boundary in Fig. 4.
3. Lognormal distribution with density  $\phi(\log t)/t$  for  $t > 0$  with  $\phi(t)$  as defined in item 1.
  - a. Variance =  $e^2 - e = 4.671 = (2.161)^2$ .
  - b. The same boundary as in item 3b holds.
  - c.  $ER = n \int_0^\infty \phi(t)(e^t - e^{-t})(\phi^m(t - \phi^m(-t))) dt$ , where  $m = n - 1$  and  $\phi(x) = \int_{-\infty}^x \Phi(t) dt$ . for  $n = 4$  utilizing subroutine for  $\Phi(x)$  in IMSL (International Mathematical and Statistical Library), 16-point Gaussian quadrature gives  $ER = 3.189977$  and 20-point gives 3.189989.

### A. A Method for Handling Single Data Plots

Another approach suggested by Bolton (11) in constructing a quality control chart, based upon a single numerical value for each lot or batch, is to use the relative standard deviation (RSD) of the data set:

$$\text{RSD (in \%)} = (s/\bar{x}) \cdot 100$$

Where RSD, formerly called the coefficient of variance, brings together in a single numerical value the central tendency ( $\bar{x}$ ) and the dispersion ( $s$ ) of the lot or batch data set. The quality control chart is then constructed by determining the mean and range of RSD values of adjacent paired lots or batches. The resulting plotted values now lie half way between the formal paired sequential batch numbers. The grand average ( $\bar{\bar{x}}$ ) and the average range ( $\bar{R}$ ) are then used to construct the Quality Control Chart in the usual manner.

Such data are shown in Table 3 and Fig. 6. Upper and lower control limits are calculated based upon  $n = 2$  and  $A_2 = 1.880$ . Thus, for 10 lots there will be 9 data points to plot, which results in a robust analysis of the quality control data for the product. Unlike a normal control chart, when you decide to use RSD values to create the quality control chart, the lower control limit (LCL) is more desirable than the upper control limit (UCL) simply because lower RSD values reflex a tighter dispersion around the mean.

**Table 3** Blend Uniformity Analysis

Batch number	Mean value ( $\bar{x}$ )	Std. dev. (s)	RSD value (%)
1	96.2	5.19	5.4
2	97.3	4.02	4.1
3	96.8	4.06	4.2
4	95.8	4.57	4.8
5	101.0	2.93	2.9
6	98.6	6.46	6.6*
7	97.5	4.19	4.3
8	98.3	5.01	5.1
9	102.6	3.25	3.2
10	97.1	5.53	5.7
Averages	98.1	4.52	4.6

Construction of the Relative Standard Deviation Control Chart for Blend Uniformity

Average RSD values	R (range) values	N = 2
4.8	1.3	
4.2	0.1	Upper Control Limit
4.5	0.6	UCL = 4.6 + 1.88 (1.5)
3.9	1.9	UCL = 7.4
4.8	3.7	
5.5	2.3	Lower Control Limit
4.7	0.8	LCL = 4.6 - 1.88 (1.5)
4.2	1.9	LCL = 1.8
4.5	2.5	
$\bar{\bar{x}} = 4.6$	$\bar{R} = 1.5$	

The specification is based upon USP 24. An RSD of not more than 6% for ten samples and not more than 7.8% for 30 samples.

\*RSD values was 6.6 after testing 30 samples.

$\bar{\bar{x}} = 4.6$ .

## REFERENCES

1. *Federal Register* 33653:40-155 (1975).
2. Grant, E. L. and Leavenworth, R. S. *Statistical Quality Control*, 6th ed., McGraw-Hill, New York (1980).
3. Ott, E. R., *Process Quality Control*, McGraw-Hill, New York (1975).
4. Schrock, *Quality Control and Statistical Methods*, Reinhold, New York (1957).
5. Cox, D. R. *Biometrika* 41:469 (1954).
6. Tippet, L. H. C., *Biometrika* 17:364 (1925).
7. David, H. A., *Biometrika* 41:463 (1954).

8. Duncan, A. J. In *Quality Control and Industrial Statistics*, Richard D. Irwin, p. 451 (1974).
9. Keen, J. and Page, D. J., *Appl. Statistics* 2:13 (1953).
10. Woodward, R. H. and Goldsmith, P. L., *Cumulative Sum Techniques*, Oliver & Boyd (1964).
11. Bolton, S. *Pharmaceutical Statistics Practical & Clinical Applications*, third edition Marcel Dekker (1998).

# 19

## Statistical Methods for Uniformity and Dissolution Testing

**James S. Bergum**

*Bristol-Myers Squibb Company, New Brunswick, New Jersey, U.S.A.*

**Merlin L. Utter**

*Wyeth Pharmaceuticals, Pearl River, New York, U.S.A.*

### I. SAMPLING

A manufacturing process may involve drying and granulation steps as well as intermediate and final mixing steps. Once a blend has been mixed, it may be transported to another location for screening or tableting (or encapsulation). Sampling can be performed at any of these steps in the manufacturing process. Samples can be taken when the blend is in a mixer, while being discharged from the mixer, when it is in a transport container (e.g., drum), throughout tablet compression or encapsulation, and after film coating (if appropriate). Sampling plans need to be developed at each of these stages.

There are two sampling plans that are generally used when testing blends or final product. In the first plan (sampling plan 1), a single test result is obtained from each location sampled. For example, in a blending step, a single test result would be obtained from each of a number of different locations within the blender. In a drum, a single test result might be obtained from the different locations within the drum or from each of a number of different drums. For final tablets, a single tablet may be tested from various time points throughout the tableting run. In the second plan (sampling plan 2), more than one test result is obtained from each of the sampled locations. For example, during the tableting operation, if a cup is placed under the tablet press at specific time points during the tableting run, several of the tablets from each cup sample would be

tested for content uniformity. Sampling plan 2 allows for estimation of between location and within location variability.

It is assumed for the remainder of this entry that the same number of units is tested from each of the sampled locations (i.e., it is a balanced sampling plan). Regardless of what sampling plan is used to determine testing, multiple units are normally collected at each of the sample locations during validation to serve as contingency samples for possible later testing.

## **A. Power Blend Sampling**

Based on the interpretation of the Wolin court decision (*U.S. v. Barr Laboratories*), the allowable size of sample taken from powder blends has been set at no more than three times the dosage unit weight. A perplexing problem facing oral solid dosage form manufacturers today is the difficulty in applying this unit dose sampling to blend uniformity validation because of the current limitations in sampling technologies. An excellent discussion of blend sampling is given in the Parenteral Drug Association (PDA) technical report on blend uniformity [1]. Much of the following discussion is taken from that paper.

There is a great deal of frustration among oral solid dosage form manufacturers caused by unit dose sampling of blends. Companies have obtained very uniform results when testing the finished dosage form (i.e., tablets or capsules) while obtaining highly variable results when attempting to comply with the current FDA position on blend uniformity sampling.

It is generally recognized that a thief is far from an ideal sampling device due to a propensity to provide nonrepresentative samples (i.e., the sample has significantly different physical and chemical properties from the powder blend from which it was withdrawn). Although simple in concept, demonstrating blend uniformity is complicated by this potential for sampling error. The current technology does not yet provide a method for consistently obtaining small representative samples from large static powder beds. It is hoped that these problems may soon be overcome by using X-ray fluorescence and near-infrared spectroscopy methods to measure blend uniformity.

As stated in the PDA technical report [1], sampling error can be influenced by: (1) the design of the thief, (2) the sampling technique, and/or (3) the physical and chemical properties of the formulation. The physical design of the thief can affect sampling error, since the overall geometry of the thief can influence the sample that is collected. Surface material can fall down the side slit of a longitudinal thief as it is inserted into a powder bed. The sampling technique can also have an impact on sampling error. As the thief is inserted into a static powder, it will distort the bed by carrying material from the upper layers of the mixture downward toward the lower layers. The angle at which the thief is inserted into the powder bed can also influence sampling error. The physical

and chemical properties of the formulation can also affect sampling error. The force necessary to insert a long thief into a deep powder bed can be appreciable. This force, depending on the physical properties of the formulation, can lead to compaction, particle attrition, and further distortion of the bed. Ideally, the thief should be constructed from materials that do not preferentially attract the individual components of the formulation. In general, the potential for sampling error increases as the size of the sample and/or the concentration of drug in the formulation decreases. Samples obtained using thief probes can be subject to significant errors.

## B. Finished Product Sampling

Two of the most common tests for finished product that have acceptance criteria are content uniformity and dissolution. The *United States Pharmacopeia* (USP 25) requirements for content uniformity for both tablets and capsules as well as for dissolution are summarized in Tables 1–3.

When collecting samples to evaluate these tests, it is important to maintain the location identity of all samples taken and to maintain this identity throughout the testing regimen. Validation is the one time when the exact location in the batch is known for each of the individual dosage units tested. By showing that each of the sample locations tested provides acceptable results, a justification is developed for later combining the tablets or capsules into a quality control (QC) composite sample for the release testing of future batches. If a two-sided press is used for tableting, the identity of the side of the press from which the samples were taken should also be maintained.

It is recommended that individual dosage units be tested from as many different sample locations as possible. The number of units tested could even

**Table 1** USP 25 Content Uniformity Test Requirements for Tablets

Stage	Number tested	Pass stage if
S <sub>1</sub>	10	Each of the 10 units lies within the range of 85.0–115.0% of label claim, and the relative standard deviation (or RSD) is less than or equal to 6.0%.
S <sub>2</sub>	20	No more than one unit of the 30 units (S <sub>1</sub> + S <sub>2</sub> ) is outside the range of 85.0–115.0% of label claim, no unit is outside the range of 75.0–125.0% of label claim, and the RSD of the 30 units (S <sub>1</sub> + S <sub>2</sub> ) does not exceed 7.8%.

*Note:* For tablets where average of potency limits is 100.0% or less.

**Table 2** USP 25 Content Uniformity Test Requirements for Capsules

Stage	Number tested	Pass stage if
S <sub>1</sub>	10	Not more than one of the 10 units lies outside the range of 85.0–115.0% of label claim, no unit is outside the range of 75.0–125.0% of label claim, and the RSD is less than or equal to 6.0%.
S <sub>2</sub>	20	No more than three of the 30 units (S <sub>1</sub> + S <sub>2</sub> ) are outside the range of 85.0–115.0% of label claim, no unit is outside the range of 75.0–125.0% of label claim, and the RSD of the 30 units (S <sub>1</sub> + S <sub>2</sub> ) does not exceed 7.8%.

*Note:* For tablets where average of potency limits is 100.0% or less.

be tied to run length, with more units tested when the run length goes across multiple shifts. A discussion of the effect of sample size on one of the methods discussed, the CuDAL approach, is provided in Sec. II.F. Because sampling plan 2 allows for the estimation of both between-location and within-location variability, this plan is generally recommended when testing individual dosage units for content uniformity. For dissolution, one might choose either sampling plan 1 or sampling plan 2, depending upon how many total units are tested.

## II. STATISTICAL TECHNIQUES AND APPROACHES

Since the start of validation in the late 1970s, there has been little published on the statistical aspects of conducting a successful process validation. What follows are some of the statistical techniques that have been either suggested in

**Table 3** USP 25 Dissolution Test Requirements

Stage	Number tested	Pass stage if
S <sub>1</sub>	6	Each unit is not less than $Q + 5\%$ .
S <sub>2</sub>	6	Average of 12 units (S <sub>1</sub> + S <sub>2</sub> ) is equal to or greater than $Q$ and no unit is less than $Q - 15\%$ .
S <sub>3</sub>	12	Average of 24 units (S <sub>1</sub> + S <sub>2</sub> + S <sub>3</sub> ) is equal to or greater than $Q$ , not more than two units are less than $Q - 15\%$ , and no unit is less than $Q - 25\%$ .

the literature or used in practice when conducting validation studies. Their use in the development of validation criteria will be discussed in Sec. III. One method was proposed by Bergum [2] to calculate content uniformity and dissolution acceptance limits (called CuDAL). A discussion of many of the other techniques can be found in Hahn and Meeker [3]. Other techniques that have been applied to validation data but are not discussed in detail in this chapter are analysis of variance (ANOVA) and process capability analysis. In the following subsections, let  $\bar{X}$  and  $s$  denote the mean and standard deviation of a sample of size  $n$  and let  $t$  and  $F$  be the critical values for the  $t$ - and  $F$ -distributions with their associated degrees of freedom and confidence levels. Let  $MSB$  be the between-location mean square from the one-way ANOVA.

### A. Tolerance Interval

A *tolerance interval* is an interval that contains at least a specified proportion  $P$  of the population with a specified degree of confidence,  $100(1 - \alpha)\%$ . This allows a manufacturer to specify that at a certain confidence level at least a fraction of size  $P$  of the total items manufactured will lie within a given interval. The form of the equation is

$$\bar{X} \pm k s$$

where  $k$  = tabled tolerance factor and is a function of  $1 - \alpha$ ,  $P$ ,  $n$  and whether it is a one- or two-sided interval.

### B. Prediction Interval

A number of prediction intervals can also be generated. A *two-sided prediction interval for a single future observation* may be of interest. This is an interval that will contain a future observation from a population with a specified degree of confidence,  $100(1 - \alpha)\%$ . The form of this equation is

$$\bar{X} \pm k s$$

where

$$k = t_{1-\alpha/2, n-1} \sqrt{1 + 1/n}$$

Another type of prediction interval that might be of interest is a one-sided upper prediction interval to contain the standard deviation of a future sample of  $m$  observations, again with a specified degree of confidence,  $100(1 - \alpha)\%$ . This is called the *standard deviation prediction interval* (SDPI). The form of this equation is



$$s\sqrt{F_{1-\alpha, m-1, n-1}}$$

### C. Confidence Interval

Confidence intervals can be generated for any population parameter. Specifically, a two-sided confidence interval about the mean is an interval that contains the true unknown mean with a specified degree of confidence,  $100(1 - \alpha)\%$ . The form of this equation, which depends on the sampling plan, is as follows. For sampling plan 1

$$\bar{X} \pm ks$$

where

$$k = t_{1-\alpha/2, n-1} / \sqrt{n}$$

For sampling plan 2

$$\bar{X} \pm k\sqrt{MSB}$$

where

$$k = t_{1-\alpha/2, \# \text{ locations}-1} / \sqrt{(\# \text{ locations}) (\# \text{ per location})}$$

[Note: for any stated confidence level, the confidence interval about the mean is the narrowest interval, the prediction interval for a single future observation is wider, and the tolerance interval (to contain 95% of the population) is the widest.]

### D. Variance Components

Variance components analysis has been used in a number of applications within the pharmaceutical industry. The power of this statistical tool is the separation or partitioning of variability into nested components. The approach requires using sampling plan 2 so that the between-location and within-location variance components can be estimated. These estimates can be calculated using one-way analysis of variance (ANOVA). The within-location variance is estimated by the mean square error, whereas the between-location variance is estimated by subtracting the mean square error from the mean square between locations and then dividing by the number of observations within each location. When applied to the blending operation, the method allows us to determine the between-location variance, which quantifies the distribution of active throughout the blend, and the within-location variance, which in turn is composed of sampling error, assay variance, and a component related to the degree of mixing on the “micro” scale. The total variance in the container or mixer is the sum of the two variance

components. Similarly, one may also determine these components in the product. Here, the within-location variance will again consist of the assay variance, the sampling error, and the micro mixing component in addition to the weight variation. The between-location component is that variance associated with macro changes in the blend environment. It is this component that reflects the overall uniformity of the blend and is minimized when optimum blender operation is achieved.

## E. Simulation

Monte Carlo simulation can be used to estimate the probability of passing multiple-stage tests such as content uniformity and dissolution. This technique is performed by generating computer-simulated data from a specific probability distribution (e.g., normal) and then using these generated sample data as if they were actual observations. The multiple-stage test is then applied to the data. This process can be repeated many times to evaluate various test properties (e.g., determining the probability of passing the multiple stage test for specific values of the population mean and standard deviation of a normal distribution).

## F. CuDAL Approach

Bergum [2] published a method for constructing acceptance limits that relates the acceptance criteria directly to multiple stage tests, such as the USP 25 content uniformity and dissolution tests. These acceptance limits are defined to provide, with a stated confidence level  $(1 - \alpha)100\%$ , a stated probability  $P$  of passing the test. For example, one can make the statement that with 95% confidence there is at least a 95% probability of passing the USP 25 test. Both the USP 25 content uniformity and the USP 25 dissolution tests have been evaluated. In each case, the required limits are provided in "acceptance tables," which are computer-generated. These tables change with the confidence level  $(1 - \alpha)$ , the probability bound  $P$ , the sample size  $n$ , and whether tablets or capsules are being evaluated (for content uniformity) or the  $Q$  value (for dissolution). Confidence levels as well as values for  $P$  are typically 50%, 90%, or 95%. The PDA technical report [1] suggests the use of a 90% confidence level to provide 95% coverage. The FDA prefers a 95% confidence level. A 50% confidence level can be considered a "best estimate" of the coverage. An SAS program has been written and validated to construct acceptance limit tables for the USP 25 content uniformity and dissolution tests for both sampling plans 1 and 2. A compact disc containing the SAS programs, user guide, and validation report can be obtained free of charge by contacting James Bergum at Bristol-Myers Squibb.

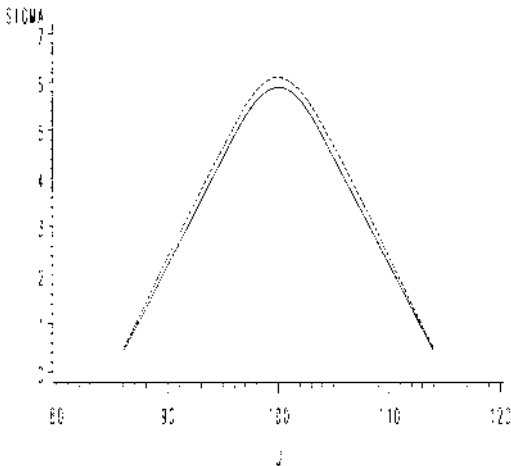
## 1. Statistical Basis

The CuDAL approach uses the fact that these are multiple-stage tests. A multiple-stage test is one in which each stage has requirements for passing the test. As can be seen in Tables 1–3, the USP 25 content uniformity and dissolution tests are multiple-stage tests with multiple criteria at each stage. The lower bound, LBOUND (also called  $P$ ), for the probability of passing the USP 25 content uniformity and dissolution tests, uses the following relationship:

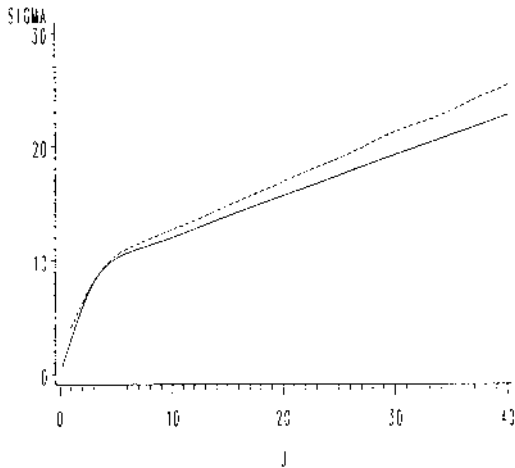
$$\text{Prob}(\text{passing USP 25 test}) \geq \max \{ \text{Prob}(\text{passing } i\text{th stage}) \}$$

where  $i = 1$  to  $S$  ( $S$  = number of stages in USP 25 test). One requirement for this inequality to hold for a multiple-stage test is that failure of the overall test at any stage also results in failure of the overall test at any subsequent stage.

Assume that the test results follow a normal distribution with mean  $\mu$  and standard deviation  $\sigma$ . Sigma ( $\sigma$ ) is the standard deviation of a single observation. For a given value of  $\mu$  and a given value of  $\sigma$ , LBOUND can be determined by calculating the probability of passing all of the requirements at each stage. Figures 1 and 2 compare the 95% contours for the calculated bound LBOUND and for the true probability of passing the USP 25 test, calculated by simulation. If  $\mu$  and  $\sigma$  are on the 95% LBOUND contour, then at least 95% of the samples tested using the USP 25 test would pass the test. These figures show how close



**Figure 1** 95% contour plots for probability of passing USP 25 content uniformity test for tablets. Solid line indicates computed LBOUND; dashed line indicates simulation result.



**Figure 2** 95% contour plots for probability of passing USP 25 dissolution test. Solid line indicates computed LBOUND; dashed line indicates simulation result.

the calculated bounds are to the simulated results for both the USP 25 content uniformity and dissolution tests.

The LBOUND can be used to develop acceptance criteria by constructing a simultaneous confidence interval for  $\mu$  and  $\sigma$  from the data. If a 90% confidence interval was constructed for  $\mu$  and  $\sigma$  and the entire interval was below the 95% LBOUND, then with 90% confidence at least 95% of the samples tested would pass the USP 25 test. For sampling plan 1, the sample mean and sample standard deviation estimate the population parameters  $\mu$  and  $\sigma$ . A simultaneous confidence interval for  $\mu$  and  $\sigma$  is given in Lindgren [4]. Since the variance of a single observation using sampling plan 2 is the sum of the between-location and within-location variances,  $\sigma$  (i.e., the standard deviation of a single observation) is estimated by calculating the square root of the sum of the between- and within-location variance components. A confidence interval for  $\sigma$  is given by Graybill and Wang [5]. The simultaneous confidence interval for  $\mu$  and  $\sigma$  is constructed by using a Bonferroni adjustment on the two individual confidence intervals for  $\mu$  and  $\sigma$ . Once the confidence interval is constructed, it must fall completely below the LBOUND specified. An acceptance limit table can be generated by finding the largest sample standard deviation for a fixed sample mean such that the resulting confidence interval remains below the pre-specified LBOUND.

## 2. Effect of Sample Size

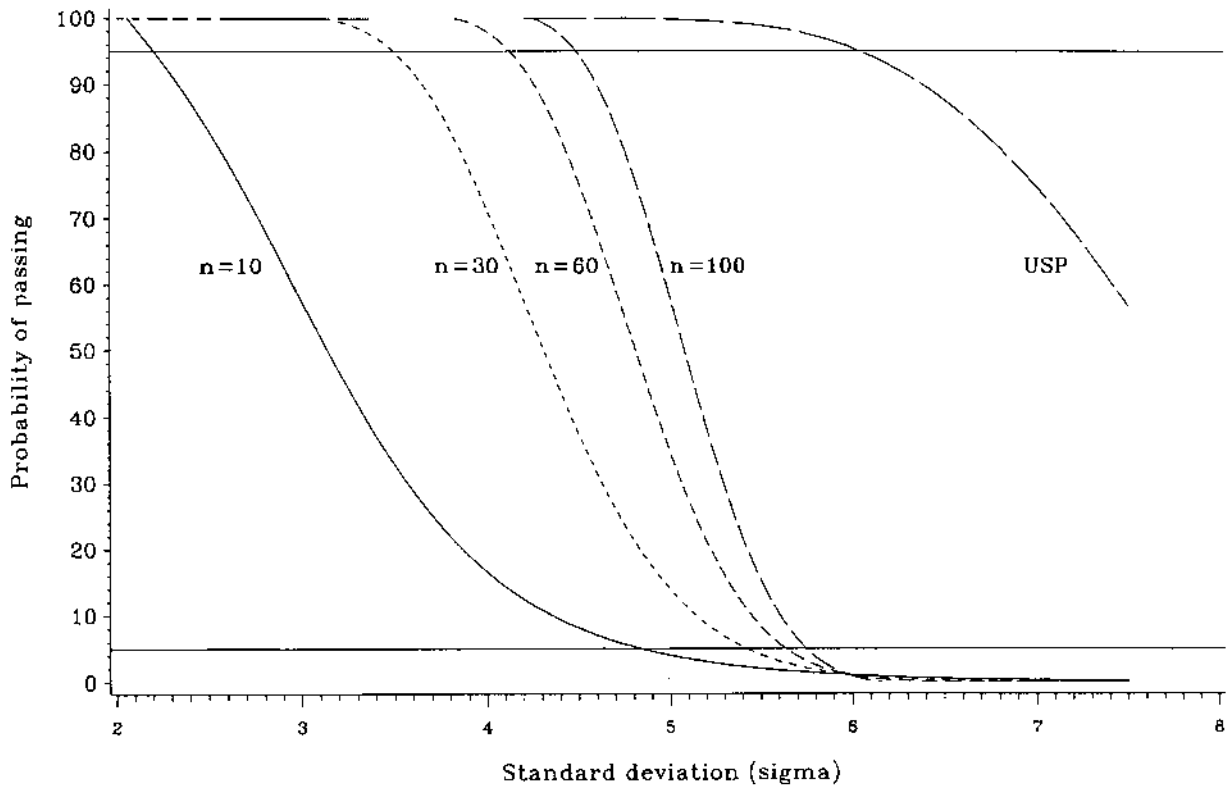
Through the use of operating characteristic (OC) curves, the effect of sample size on the ability to pass the CuDAL approach can be evaluated. The OC curves provide estimates of the probability of passing the CuDAL approach over a number of different population mean and standard deviation values. Figures 3 and 4 provide OC curves for specific sample sizes using sampling plans 1 and 2, respectively. For these plots a mean of 100% was assumed with the tablet dosage form. A confidence level of 90% to obtain 95% coverage was also used. The estimated probability of passing the USP 25 content uniformity test was included for comparison.

Figure 3 provides the OC curves using sampling plan 1 for sample sizes of 10, 30, 60, and 100. As expected, the probability of passing the acceptance limit table increases as the sample size increases. For example, if  $n$  is 30, the probability of passing the acceptance limit table for tablets when  $\sigma$  is 4.0% is approximately 75%. To increase the probability of passing the CuDAL approach with this type of true quality, a larger sample size would be needed.

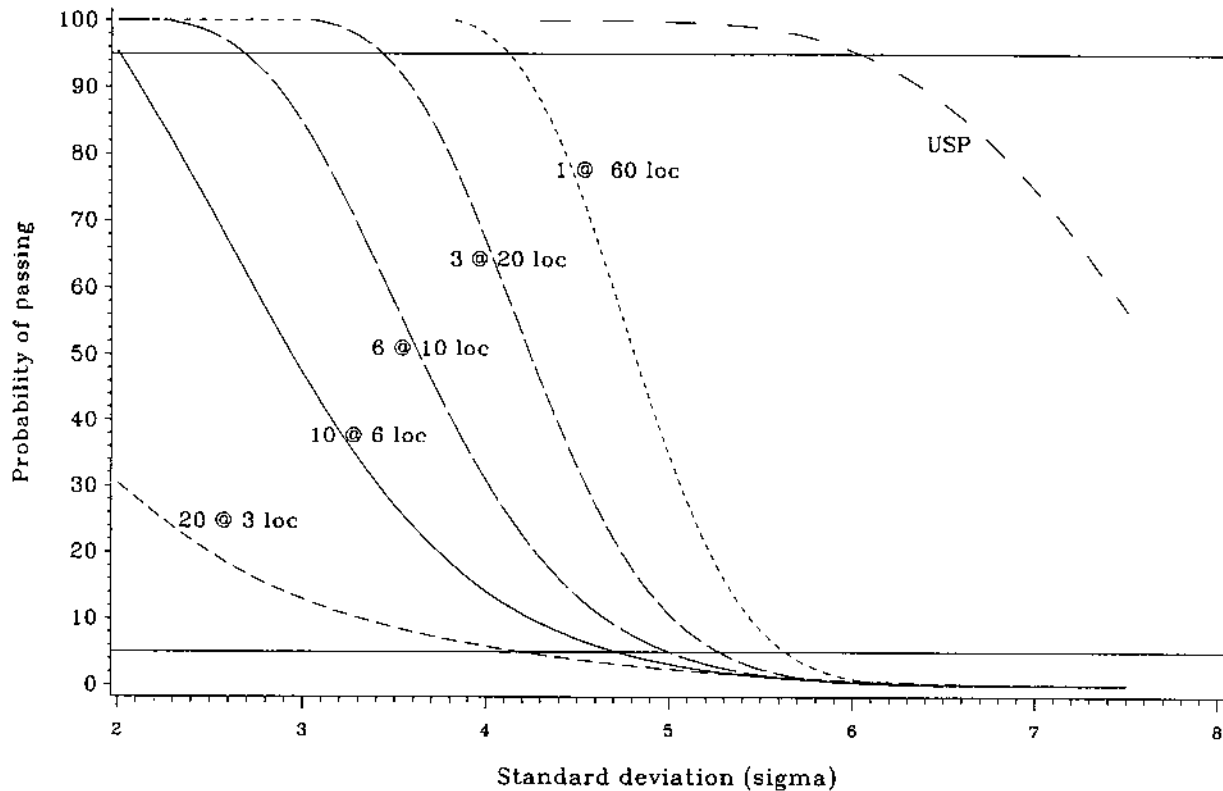
Figure 4 provides the OC curves using sampling plan 2 for a sample size of 60 but with different numbers of locations sampled. The results are compared to the use of sampling plan 1 without any replication. It is assumed for this plot that half of the total variation is due to between-location variance and half is due to within-location variance (i.e., factor = 0.5). Note that the number of locations has a significant effect on the probability of passing the acceptance limit table. This effect would have been even larger if the percentage of variation due to locations was assumed to have been something greater than one-half. It is recommended that when using sampling plan 2, the number of locations used be as large as possible. For example, if a total of 60 tablets are sampled across the batch, it is better to sample three from each of 20 locations than 20 from each of three locations.

## III. COMPARISON OF ACCEPTANCE CRITERIA

There are a number of tests that are performed during validation. In the blends, the primary interest is in showing that the blend is uniform in drug content. Uniformity can also be evaluated in the drums to ensure that segregation or demixing did not occur during transfer. The overall potency is generally not considered a critical variable in the blends, since it is neither enhanced nor diminished by additional mixing. There may be a concern with potency loss during processing or storage between processing steps, however; for example, after emptying the blended powder into transports or as a result of tablet compression. In the final product, content uniformity and dissolution (and to a lesser



**Figure 3** Probability of meeting CuDAL acceptance table for sampling plan 1. Mean = 100.0%, 90% assurance/95% coverage, tablets.



**Figure 4** Probability of meeting CuDAL acceptance table for sampling plan 2. Mean = 100.0%, 90% assurance/95% coverage, factor = 0.5, tablets.

extent, potency) are of primary interest. Acceptance limits are generally developed for these tests. Other tests that are performed, such as particle size, bulk/tap density and flow, hardness, friability, and weight variation, may or may not have formal, statistically derived acceptance limits.

There are almost as many approaches to validation as there are companies performing validation. What follows is a discussion of some of the methods of statistical analysis, along with their advantages and disadvantages. Two proposals, one from the FDA for blends and another by the PDA, called a “holistic” approach to validation, are also discussed. The advantages and disadvantages of these methods are listed in Tables 4 and 5 for powder blends and finished product (tablets/capsules), respectively. Note that what might be an advantage to one person can be a disadvantage to the next.

**Table 4** Advantages and Disadvantages of Various Statistical Techniques for Powder Blends

Test	Advantages	Disadvantages
<i>Blend uniformity</i>		
1. FDA approach	Accepted by the FDA	Not statistically based; penalized for large n; adversely affected by constant loss of potency
2. SDPI	Rewarded for larger n Not affected by constant loss of potency; tied to part of stage 1 USP 25 CU test	Difficult to apply with sampling plan 2; not tied directly to full USP 25 CU test
3. Tolerance interval	Easy to calculate; rewarded for larger n	Not tied directly to full USP 25 CU test; difficult to apply for sampling plan 2; factors can be hard to find for nonstandard coverage probabilities
4. CuDAL approach	Rewarded for larger n; tied directly to USP 25 overall test; easy table lookup; provides high assurance of passing USP 25 test	Computer program required (but can be provided); difficult to pass using sampling plan 2 with few locations
5. Holistic approach	Provides chance to recover from variable blender results	Substitution of variance components concept may be a hard sell; degrees of freedom can be significantly reduced



**Table 5** Advantages and Disadvantages of Various Statistical Techniques for Finished Product (Tablets/Capsules)

Test	Advantages	Disadvantages
<i>CU/dissolution</i>		
1. Simulation	Tied directly to USP 25; can be tied to either stage 1 or full test Can handle asymmetric potency limits	Not a function of n; does not provide high assurance level of passing USP 25 test (only point estimate)
2. Tolerance interval	Easy to calculate; rewarded for larger n	Not tied directly to USP 25 overall test; difficult to apply for sampling plan 2; factors can be hard to find for nonstandard coverage probabilities
3. CuDAL approach	Rewarded for larger n; tied directly to USP 25 overall test; easy table lookup; provides high assurance of passing USP 25 test	Does not directly address asymmetric potency limits; computer program required (but can be provided); difficult to pass using sampling plan 2 with few locations
<i>Potency (composite assay)</i>		
1. Confidence interval	Provides strong statement that overall batch average potency is acceptable	Does not provide assurance that a given assay result will meet requirements
2. Tolerance/prediction interval	Provides strong statement that an individual assay result will meet assay requirements	Requires a large number of composite assays

## A. Powder Blends

### 1. Blend Uniformity

*Food and Drug Administration Approach.* The FDA has proposed the following acceptance criteria for blend uniformity testing [6]:

Each individual sample should meet compendial assay limits (e.g., 90.0–110.0%).

The relative standard deviation (RSD) should be no greater than 5%.  
A minimum of 10 samples should be tested.

The samples should include potential “dead spots.” The tighter RSD requirement is to allow for additional variation from possible demixing and weight or fill variation. It is stated [6] that just meeting the USP 25 content uniformity criteria is not appropriate for blends. The blend criteria also should not be relaxed because of sampling difficulties. It is more appropriate to change the sampling procedure to ensure accurate results.

The advantages of these criteria are that they are easily understood and implemented and any firm that meets them would be highly confident of satisfactorily passing a Good Manufacturing Practices (GMP) or preapproval inspection. These criteria have a number of disadvantages, however. A firm is penalized for taking more samples, since the probability of finding an out-of-range sample increases accordingly. These criteria also assume that current sampling practices can always provide a consistent collection of unit dose samples representative of the powder blend.

*Standard Deviation Prediction Interval (SDPI).* Since uniformity is of primary interest in powder blend validation and because of a concern that a constant sampling error can occur, one approach is to base the criteria only on variability. The SDPI allows one to predict, from a sample of size  $n$  and with a specified level of assurance, an upper bound on the standard deviation of a future sample of size  $m$  from the same population. This approach is recommended in the PDA paper on blend uniformity [1].

By setting the future sample size  $m$  to 10, which is the stage-1 sample size for the USP 25 content uniformity test, and by requiring that the upper bound on the standard deviation of a future sample of size 10 be less than 6.0%, which is the USP 25 stage-1 RSD requirement, the SDPI approach can be tied to the USP 25 content uniformity test. The SDPI equation in Sec. II can be rearranged to obtain the following equation:

$$s_{cr} = s_m / [F_{1-\alpha, m-1, n-1}]^{1/2}$$

where

$n$  = size of current sample

$s_{cr}$  = critical standard deviation

$s_m$  = upper bound of a future sample of size  $m$

$1 - \alpha$  = confidence level (e.g., 0.90)

$F$  = critical  $F$  value

$S_{cr}$  becomes the maximum acceptable sample standard deviation to meet the acceptance criteria. If the sample standard deviation  $s_n$  is less than  $s_{cr}$ , then we are guaranteed, with a minimum assurance of  $100(1 - \alpha)\%$ , that the upper prediction bound for a future sample of size 10 will not be greater than 6.0% of the target concentration.

*Tolerance Interval Approach.* To use the tolerance interval as an acceptance criterion, the confidence level  $100(1 - \alpha)\%$  and coverage level  $P$  need to be chosen. One approach is to assume that the blend samples are the same as the resulting final product from that blend. To tie the tolerance interval to the USP 25 content uniformity test, one choice for capsules might be to use a coverage of 90%, since the USP 25 allows three capsules out of 30 to be outside 85–115% of label claim. If the tolerance interval is completely contained within the 85–115% interval, this acceptance criterion would be met. For tablets, the coverage level would be approximately 96.7% (29/30), since only one tablet out of 30 is allowed out of 85–115% of claim. This approach is not as appealing for application to blends, since without the weight variation of the finished dosage form there is no reason that blends that go into the capsules should be any looser than the blends that go into the tablets. Use of the interval associated with tablets may be preferred. Another choice of how to define the coverage  $P$  is discussed in Ref. 1. Although it is difficult to find tolerance factors for non-standard coverage levels in published tables, they can be generated using the interval statement in the SAS/QC procedure CAPABILITY [7].

Tolerance intervals assume that sampling is done using sampling plan 1. There is only one variance component used to estimate the variance of a single observation (i.e., the sample variance). The degrees of freedom used to determine the tolerance factor  $k$  are the degrees of freedom associated with the sample variance. If sample plan 2 is used, however, there are two variance components used to estimate the variance of a single observation. The degrees of freedom must therefore be approximated. This can be done using Satterthwaite's approximation [8].

*CuDAL Approach.* Since the USP 25 content uniformity test is applied only to the finished product, application of the CuDAL approach requires that the acceptance limits for the blend be tied to either the capsule or tablet USP 25 test. The same points mentioned earlier in Sec. III, *Tolerance Interval Approach* are appropriate when deciding whether to apply the tablet to capsule test criteria to the blend data. In addition, for any of the approaches, each result is generally expressed in percentage of label claim as a percentage of active in a theoretical tablet weight. An alternative to the SDPI approach (which is not dependent upon the mean) is to express each result as a percentage of the sample mean and to then apply the CuDAL approach. This has the effect of removing the mean effect and just evaluating the variability. If this were done, then the acceptance limit would be the RSD associated with a sample mean of 100%.

*Holistic Approach.* The PDA report [1] proposes a holistic approach to the validation in which means and variances of the blend are compared to the means and variances of the final product. The validation is considered successful if all criteria are met for both the blend and the final dosage form. If the final

product fails, the validation is unsuccessful regardless of the blend results. There are, however, situations in which the final product is acceptable and the blend is unsuccessful but the true blend uniformity can be deemed acceptable. This is because the inconsistent results might be due to sampling error when sampling the blend. The blend may have good location-to-location variability, but because of sampling errors, the within-location error causes the blend results to fail. One approach given by the PDA paper [1] is to use “analysis by synthesis.” To employ this technique, sampling plan 2 must be used for both the blend and the final dosage form so that the between- and within-location variance components can be estimated. These variance components, as well as the total variance, can be tested statistically using an  $F$  test to determine if there is a significant difference between the variances at the two stages. If the within-location variance component in the blend is significantly higher than that in the final product, then the within-location variance component for the final product is substituted for the within-location variance component of the blend in an attempt to remove the effect of sampling error in the blend sample results. This reduced overall variance for the blend is compared to the acceptance criteria.

## 2. Average Potency

There may be a desire to assess possible potency loss between the different sample stages. There also may be an interest in assessing whether or not the average potency results are at the target potency. At the blender stage, the average potency can be determined either from taking the average of several potency assays or by using the average of the uniformity values if it is felt that there are no sampling issues associated with the smaller sample quantity and if the assay and content uniformity methods are the same. If it is not clear if there will be sampling issues during validation, it is suggested that when possible a formulation study be conducted prior to the validation to determine if the smaller sample quantity will provide consistent uniformity results and if not, what sample quantity will produce consistent results. With this support in hand, the smallest sample quantity that will provide consistent results should be used for the validation. It is understood, however, that it may not always be possible to conduct such prevalidation studies.

If a comparison across stages is to be performed, it is recommended that all powder results be reported as percentage of label claim and not as a percentage of theoretical, in order to provide a direct comparison of the average results to finished product. One must remember that the potency results obtained prior to any adding of lubricant must be adjusted down to account for the fact that the lubricant was not included at the time of sampling. To compare the average uniformity or potency results across stages, one can require that the averages at each stage be within some stated amount of each other or of target. Statistically

based techniques such as ANOVA or confidence intervals using the variation of the data and a stated assurance level can also be used.

## B. Finished Product

### 1. Content Uniformity and Dissolution

*CuDAL Approach.* The CuDAL approach is specifically written for tablets or capsules. This approach is recommended in the PDA paper [1] for final product testing. For content uniformity, when the potency limits are not symmetrical about 100% of label claim, the USP 25 content uniformity test allows the individual results to be expressed as either a percentage of the label claim, the found mean, or the average of the upper and lower potency specifications, depending on the value of the sample mean. Acceptance limits have not been constructed for the more complicated situation in which the potency shelf life limits are not symmetric about 100%. One approach to this problem is to evaluate the content uniformity results twice. First express the sample mean as a percentage of label claim and then express the mean as a percentage of the average of the potency specifications. To pass the acceptance limits, both means must meet the acceptance criteria. To use the dissolution acceptance limit tables, the value of  $Q$  is required.

*Simulation.* One approach is to assume the sample mean and standard deviation are the true population mean and standard deviation, to provide a “best estimate” of the true probability of passing. This has the advantage that it can provide estimates of the probability of passing at any stage and can handle the nonsymmetric potency shelf life limits in the content uniformity test. The disadvantage is that it does not provide a bound on the probability with high assurance and is not a function of sample size. It can provide a good summary statistic of the content uniformity data, however.

*Tolerance Interval.* Section III.A discusses the use of tolerance intervals as acceptance limits for content uniformity data. Tolerance intervals can also be used as acceptance limits for dissolution. Since the USP 25 dissolution test for stage 1 is that all six capsules be greater than  $Q + 5$ , the tolerance interval could be tied to the USP 25 test by requiring that the lower bound on the tolerance interval be greater than  $Q + 5$ . To obtain a 95% probability of passing at stage 1, the coverage  $P$  of the tolerance interval would need to be  $(0.95)^{1/6}$ , or 0.991. Using a tolerance interval based on stage 1 of the USP 25 test can be very restrictive.

*Confidence Interval.* Confidence intervals are not recommended for evaluating content uniformity data. An approach that is less restrictive than tolerance intervals for evaluating dissolution data, however, is to base the acceptance limits on meeting the second and third stage of the USP 25 dissolution test. Both the second and third stages require that the sample mean be less than

$Q$ , therefore a lower one-sided confidence interval for the population mean could be used as an acceptance limit. The criterion is that the lower bound on the confidence interval must be greater than  $Q$ .

## 2. Potency

Potency can also be evaluated during validation. It is assumed that some number of composite assays are tested during validation. One criterion might be to generate a  $100(1 - \alpha)\%$  confidence interval about the mean using all the potencies collected. This interval will contain the true batch potency with  $100(1 - \alpha)\%$  confidence. This interval should be contained within the potency “in-house” or release limits. Enough potencies should be looked at to have sufficient power that this interval will be contained within the desired limits.

Meeting the foregoing criterion should not be interpreted to mean that an individual composite potency assay will meet the in-house limits with high assurance. If this is desired, a prediction interval for a single future observation, or better yet, a tolerance interval, should be used. The validation specialist should be cautioned that additional composite assays might need to be tested to meet either one of these criteria with high confidence.

At a minimum, each of the composite assay results obtained should fall within the desired limits, either the potency shelf specifications or the potency in-house (or release) limits. The in-house limits are felt to be the more appropriate, since these are the limits that ensure that the product will meet the shelf limits throughout expiry.

The content uniformity results may also be used to help assess whether or not the process has acceptable potency at each point in the batch. If multiple dosage units are tested for content uniformity at each sample location (sampling plan 2) and content uniformity and potency are both tested by the same analytical method, then the average of the content uniformity values at each sample location should provide an estimate of the potency at that location. Each of these content uniformity averages can then be compared to the potency shelf specifications of 90.0–110.0% as another measure of whether each of the sample locations are indeed acceptable. It is recommended that the protocol allow for enough tablets to be tested to obtain a reliable estimate of the average. This idea of averaging the individual dosage units at each of the sample locations is employed in the PQRI proposal to the FDA for the evaluation of blend uniformity results. (See Sec. V.)

## 3. Other Validation Issues

Validation data should be plotted whenever possible. For example, content uniformity and dissolution can be plotted versus the sample locations. This allows for a visual check for trends. A criterion requiring either “no trends of note” or that some specific trend rule be met (such as Nelson’s mean square successive

difference trend test [9]) might be included as part of the acceptance criteria. Some companies use more of a process-capability approach to determine consistency of test results across sample locations.

It is desirable that samples be sent to the laboratory for testing in a designed and ordered way to be able to separate laboratory effects from process effects if it becomes necessary. For example, if four units were to be tested from each sample location, send one-half of the units from each location to the laboratory on each of 2 days. In practice, the laboratory may resist doing this.

Weights of individual dosage units should be obtained for every unit tested for both content uniformity and dissolution at the time the units are tested. This may be useful information for later investigation if unacceptable test results are obtained.

For coated products, since this is the finished form, sampling and testing should also be conducted. The emphasis is usually on the cores, however, where the sample identity across the batch is known and can be evaluated. At the coated stage, the effect of the coating solution on dissolution is probably of most interest. Individual coating pans, either all of them or some portion of them, should be sampled and tested, with pan number identity maintained.

#### **IV. EXAMPLES**

The two examples given in this section demonstrate the application of some of the statistical techniques described in previous sections using both sampling plans 1 and 2. Example 1 uses sampling plan 1 and example 2 uses sampling plan 2. In each example, samples are taken from the blend and from the final product (capsules were chosen). Samples from both the blend and final capsules are tested for content uniformity. The final capsules are also tested for dissolution. We assume that the USP 25 dissolution specification for this immediate release product has a  $Q$  of 85% at 30 min. Suppose the blend samples are taken from a V blender. This type of blender looks like a “V” with a left and right side of the “V.” Samples are taken from the front and back of each side of the blender from the top, middle, and bottom of the granulation, for a total of 12 locations. Assume that the data are in percentage of label claim units. Although a 90% confidence level is used throughout the example, 95% is also a typical confidence level. For the CuDAL approach, a 95% probability of passing is used throughout. All tolerance factors were calculated using the interval statement in the SAS/QC procedure CAPABILITY [7].

##### **A. Example 1 (Sampling Plan 1)**

###### **1. Blend**

Using sampling plan 1, a single content uniformity result is obtained from each location in the V blender, with the following results.

## Blend Data Display

Location	Side	
	Left	Right
Front		
Top	100.76	92.53
Middle	97.17	98.22
Bottom	95.64	101.91
Back		
Top	100.88	98.97
Middle	97.93	96.30
Bottom	95.63	97.13

*Note:* Mean = 97.76; standard deviation = 2.64; RSD (%) = 2.70.

For the tolerance interval approach, a 90% coverage is used, since capsules are being evaluated. (See Sec. III.A.) The 90% two-sided tolerance interval to capture 90% of the individual content uniformity results is  $97.76 \pm 2.406 = (91.41, 104.11)$ . Since the interval is completely contained within the 85–115% range, the criterion is met.

[*Note:* as mentioned in Sec. III.A., if the coverage level associated with tablets (96.7%) was used instead of the coverage level associated with capsules (90.0%), the tolerance factor would be 3.112 and the tolerance interval would be (89.54, 105.98). This, too, would meet the criterion.]

The  $s_{cr}$  based on the SDPI is  $6.0/\sqrt{2.27} = 3.98\%$ . Since the standard deviation for the example is 2.64%, which is less than  $s_{cr}$ , this sample meets the acceptance criterion.

To use the acceptance limits proposed by CuDAL, an acceptance limit table is generated to give the upper bound on the sample RSD for various values of the sample mean. For this example, the table was constructed for capsule content uniformity using a 90% confidence level with a lower bound (LBOUND) of 95%. A portion of the acceptance limit table is as follows:

Mean (percentage claim)	RSD (%)
97.5	3.64
97.6	3.66
97.7	3.68*
97.8	3.70

*Note:* \*denotes table entry of interest.



The sample mean for this example is 97.76%, so the upper limit for the sample RSD is 3.68%. It is recommended that the means always be rounded to the more restrictive RSD limit so that the assurance level and lower bound specifications are still met, so in this case 97.76% is rounded to 97.7%. Therefore, since the sample RSD of 2.70% is less than the critical RSD of 3.68, the acceptance criterion is met. This means that with 90% assurance, at least 95% of samples taken from the blender would pass the USP 25 content uniformity test for capsules. As mentioned in Sec. III.A., if the USP 25 tablet criterion were evaluated instead of the capsule criterion, the upper limit for the sample RSD would be 2.98% and would also pass.

## 2. Capsules

Assume that during encapsulation a sample was taken at each of 30 locations throughout the batch. One capsule from each location was tested for content uniformity and one for dissolution, with the following results.

---

Data Display: CU

---

99.19	96.38	98.82	98.53	94.37
97.33	95.97	101.32	97.78	97.03
97.05	94.39	100.85	97.77	95.42
95.42	96.73	101.29	96.80	103.03
99.23	97.28	97.52	100.26	95.27
97.36	91.77	98.23	98.07	98.35

---

Note: Mean = 97.63; standard deviation = 2.34; RSD (%) = 2.40.

---

Data Display: Dissolution

---

93.78	94.65	87.83	96.81	92.57	87.68
92.17	88.01	96.59	101.46	93.75	99.44
95.27	92.47	98.46	96.34	93.52	90.73
92.75	94.53	88.72	89.58	97.37	96.41
90.93	96.11	93.41	96.60	94.45	92.82

---

Note: mean = 93.84; standard deviation = 3.47; RSD (%) = 3.69.

A 90% tolerance interval to capture 90% of the individual content uniformity test results is  $97.63 \pm 2.025(2.34) = (92.89, 102.37)$ . Since this interval is contained within the 85–115% interval, the criterion is met.

Using a criterion based on passing stage 1 of the USP 25 dissolution test, a lower one-sided 90% tolerance interval to capture 99.1% of the individual dissolution values is  $93.84 - 2.930(3.47) = 83.67$ . Using this criterion, dissolution would fail, since the lower bound is less than  $\bar{Q} + 5$ , which is 90.

Using a criterion based on stages 2 and 3 of the USP 25 dissolution test, a lower one-sided 90% confidence interval for the population mean is  $93.84 - 1.311(3.47)/\sqrt{30} = 93.01$ . Since the lower bound on the confidence interval for the mean is greater than  $\bar{Q}$ , these results would pass the criterion.

The CuDAL acceptance limit table for capsule content uniformity and dissolution are as follows.

Content Uniformity ( $n = 30$ )

Mean (percentage claim)	RSD (%)
97.5	4.69
97.6	4.70*
97.7	4.72
97.8	4.73

Dissolution ( $n = 30$ )

Mean (percentage claim)	RSD (%)
93.6	8.56
93.8	8.61*
94.0	8.66
94.2	8.70

Since the sample RSD values of 2.40% for content uniformity and 3.69% for dissolution are less than the corresponding acceptance limits from the tables of 4.70% and 8.61%, both tests pass the acceptance criterion.

## B. Example 2 (Sampling Plan 2)

### 1. Blend

Two samples are taken from each location in the V blender, with the following results.

Location	Data (percentage label)		Summary statistics		
	1	2	Mean	Variance	Standard deviation
1	90.45	99.19	94.82	38.12	6.17
2	95.90	99.33	97.62	5.88	2.42
3	89.86	99.18	94.52	43.43	6.59
4	96.88	92.55	94.71	9.37	3.06
5	98.40	94.23	96.32	8.69	2.95
6	100.03	106.50	103.27	20.93	4.57
7	93.74	96.36	95.05	3.43	1.85
8	106.43	100.24	103.34	19.16	4.38
9	101.72	97.18	99.45	10.31	3.21
10	97.32	99.64	98.48	2.69	1.64
11	100.58	98.39	99.48	2.40	1.55
12	90.49	95.48	92.99	12.45	3.53

To apply the tolerance interval, SDPI, and CuDAL approaches, it is necessary to compute the following variance components.

Variance components		
Source	Mean square	Estimate (standard deviation)
Between	23.20	2.056
Within	14.74	3.840
Total		4.356

The estimated standard deviation of a single observation is 4.356.

To use the tolerance interval approach, the Satterthwaite approximate degrees of freedom (d.f.) is 21.48. The 90% tolerance interval to capture 90% of the individual capsule content uniformity results is  $97.50 \pm 2.112(4.356) = (88.30, 106.70)$ . The tolerance factor was determined using linear interpolation. This would meet the criterion, since the interval is completely contained within the interval 85–115%. As mentioned in Sec. III.A, if the coverage level associated with tablets (96.7%) was used instead of the coverage level associated with capsules (90.0%), the tolerance factor would be 2.731 and the tolerance interval would be (85.60, 109.40). This would just barely meet the acceptance criterion.

The  $s_{cr}$  using the SDPI is  $6.0/\sqrt{1.94} = 4.31$  using the d.f. from the Satterthwaite approximation. The sample standard deviation (4.356) does not pass this criterion.

The CuDAL approach requires calculating the standard deviation of the location means, the within-location standard deviation, and the overall mean.

$$\begin{aligned} \text{Mean} &= 97.50 \\ \text{SE (within location standard deviation)} &= 3.84 \\ \text{Standard deviation of location means} &= 3.41 \end{aligned}$$

The standard deviation of location means is computed by taking the standard deviation of the location means. It is *not* the between-location variance component.

A portion of the acceptance limit table generated to meet the capsule criterion is as follows.

Standard Deviation of Location Means

SE	3.3		3.4		3.5	
	LL	UL	LL	UL	LL	UL
3.7	98.7	101.9	99.5	101.5	100.5	101.0
3.8	99.0	101.8	99.8	101.3	100.9	100.9
3.9	99.3	101.6	100.2	101.2	•	•

The lower (LL) and upper (UL) acceptance limits for the sample mean are given for various values of the standard deviation of location means and the within-location standard deviation (SE). For our example, after rounding the standard deviation estimates up to the more restrictive values, the combination of 3.5 for the standard deviation of location means and SE of 3.9 is off the table, so this combination has too large a combination of standard deviations to pass the criterion. Therefore, the criterion fails. If the USP 25 tablet criterion were evaluated instead of the capsule criterion, this would be even more restrictive and would also fail the criterion.

## 2. Capsules

Suppose that four capsules are tested at each of 15 locations throughout the batch for content uniformity and dissolution, with the following results.

CU

Location	Data (percentage label)				Summary statistics		
	1	2	3	4	Mean	Variance	Standard deviation
1	97.08	99.72	98.37	93.50	97.17	7.13	2.67
2	99.72	100.32	101.01	100.29	100.33	0.28	0.53
3	99.90	98.27	98.88	97.96	98.75	0.73	0.85
4	92.78	92.17	93.44	91.22	92.40	0.89	0.94
5	96.32	96.61	95.66	97.20	96.45	0.42	0.64
6	100.97	102.17	99.06	98.80	100.25	2.57	1.60
7	97.02	95.35	98.65	95.98	96.75	2.08	1.44
8	99.39	98.81	98.63	98.06	98.72	0.30	0.55
9	99.59	97.80	97.67	95.95	97.75	2.21	1.49
10	97.97	98.54	100.26	98.74	98.88	0.96	0.98
11	96.09	97.61	95.49	97.50	96.67	1.10	1.05
12	98.87	97.81	97.28	98.80	98.19	0.60	0.78
13	101.10	102.60	100.48	98.62	100.70	2.71	1.65
14	100.80	100.34	98.49	100.93	100.14	1.27	1.13
15	99.70	100.09	100.14	99.20	99.78	0.19	0.43

Variance Components

Source	Mean square	Estimate (standard deviation)
Between	18.486	2.057
Within	1.563	1.250
Total		2.407

A 90% tolerance interval to capture 90% of the individual content uniformity results using the Satterthwaite approximation of 21.56 d.f. is  $98.20 \pm 2.111(2.407) = (93.12, 103.28)$ . The tolerance interval indicates that the capsules have good content uniformity.

The descriptive statistics to use the CuDAL approach are

$$\begin{aligned} \text{Mean} &= 98.20 \\ \text{SE (within-location standard deviation)} &= 1.25 \\ \text{Standard deviation of location means} &= 2.15 \end{aligned}$$

The portion of the table for this combination of results is

### Standard Deviation of Location Means

SE	2.0		2.1		2.2	
	LL	UL	LL	UL	LL	UL
1.2	91.7	108.3	92.0	108.0	92.3	107.7
1.3	91.8	108.2	92.1	107.9	92.4	107.6*
1.4	91.8	108.2	92.1	107.9	92.4	107.6

The lower and upper acceptance limits for the mean are 92.4 to 107.6. Since 98.2 falls within the interval, the capsules pass the acceptance criterion.

### Dissolution

Location	Data (percentage released)				Summary statistics		
	1	2	3	4	Mean	Variance	Standard deviation
1	101.4	99.5	92.9	94.9	97.16	15.55	3.94
2	106.6	101.4	98.0	100.0	101.51	13.53	3.68
3	103.9	100.6	95.3	100.5	100.07	12.64	3.56
4	96.6	93.5	92.6	94.5	94.28	2.89	1.70
5	89.4	93.1	84.6	92.4	89.89	14.97	3.87
6	90.9	90.7	93.2	91.9	91.67	1.39	1.18
7	93.8	92.6	94.8	99.8	95.27	10.08	3.17
8	99.8	98.6	98.1	92.4	97.23	11.03	3.32
9	92.4	96.0	98.4	88.8	93.90	17.86	4.22
10	100.8	99.5	90.6	99.0	97.50	21.50	4.64
11	95.9	98.2	95.9	95.9	96.47	1.39	1.18
12	103.8	103.4	100.8	104.0	102.99	2.28	1.51
13	95.2	92.2	96.1	94.2	94.43	2.88	1.70
14	96.4	98.7	95.4	101.7	98.03	7.69	2.77
15	95.7	96.7	96.2	95.9	96.13	0.17	0.41

### Variance Components

Source	Mean square	Estimate (standard deviation)
Between	48.253	3.130
Within	9.056	3.009
Total		4.342

A 90% one-sided tolerance interval to capture 99.1% of the individual dissolution values using the Satterthwaite approximation of 31.13 d.f. is  $96.44 - 2.907(4.342) = 83.82$ . The tolerance interval indicates that the capsules are not assured of passing stage 1 of the USP 25 dissolution test. The confidence interval approach based on stage 2 and 3 of the USP 25 dissolution test has a lower bound for the population mean of  $96.44 - 1.345 * \sqrt{48.25/\sqrt{60}} = 95.23$ . Since the lower bound of 95.23 is greater than  $Q$ , the criterion is met.

Using the CuDAL approach, the descriptive statistics are

Mean = 96.44  
 SE (within-location standard deviation) = 3.01  
 Standard deviation of location means = 3.47

The portion of the acceptance limit table for this combination of results is

Standard Deviation of Location Means			
SE	3.25	3.50	3.75
2.75	88.80	89.10	89.40
3.00	88.90	89.10	89.40
3.25	88.90	89.20*	89.40

The lower acceptance limit for the mean is 89.20%. Since 96.44 is greater than 89.20, the capsules pass the acceptance criterion for dissolution.

### C. Analysis by Synthesis

Notice that in example 2, the blend failed content uniformity but the capsules passed. The approach given in the PDA paper [1] applies an analysis by synthesis as follows:

1. Calculate the variance components for the blend and final capsules.

Variance components	Standard deviation	
	Blend	Capsules
Between location	2.056	2.057
Within location	3.840	1.250
Total	4.356	2.407

2. Compare variance components.
  - a. *Within-location standard deviations*: Compare 3.84 in the blend to 1.25 in the capsules. The  $F$  test two-sided  $p$  value is less than

0.001, indicating a significant reduction in within-location standard deviation.

- b. *Total variance*: Compare 4.356 in the blend to 2.407 in the capsules. The  $F$  test two-sided  $p$  value is less than 0.01, indicating a reduced overall variation in the capsules.
3. Substitute the capsule within location for blend within location.

Variance components

Blend between-location standard deviation = 2.056

Capsule within-location standard deviation = 1.250

Total = 2.406

In this example, this reduces the total standard deviation for the blend from 4.356 to 2.406. The Satterthwaite d.f. is 2.00. It is noted in the PDA technical report (1) that “sometimes this [i.e., using Satterthwaite’s approximation] will result in a number less than any of the d.f. associated with the individual mean-square terms used in the computation. It is suggested that in such cases the d.f. be selected to be no less than the lesser of these mean-square d.f.’s.” This occurred in the preceding example, and so 11 was selected as the appropriate d.f. for the total synthesized variance. With this, a  $s_{cr}$  of 3.98 is obtained and the blend passes.

## V. FUTURE DEVELOPMENTS

A draft FDA guidance document on blend uniformity for abbreviated new drug application (ANDA) products [10] was issued in 1999 to suggest in-process acceptance criteria for routine blend uniformity analysis (BUA) of postvalidation ANDA production lots. The Product Quality Research Institute (PQRI) has since formed a blend uniformity working group (BUWG) to address how best to conduct postvalidation testing to satisfy the current Good Manufacturing Practices (cGMP) requirements for routine in-process monitoring of blend uniformity, as well as how to overcome some of the sampling problems associated with blend uniformity testing during validation. Their proposal [11] centers on the testing of in-process dosage units in lieu of the required blend testing, when combined with a stratified sampling strategy and appropriate acceptance criteria to assess whether each sampled location is acceptable. The PQRI, founded to conduct research to support science-based regulatory policy, consists of members from the FDA, industry, and academia. A recommendation has been submitted to the FDA recommending that the draft ANDA guidance on BUA include stratified in-process sampling and analysis of dosage units as an alternative to direct blend sampling to demonstrate uniformity and homogeneity. It is possible



that this proposal, if accepted by the FDA, will eventually find its way to new drug application (NDA) products.

As part of the international harmonization of test methods, a proposed change to the USP <905> content uniformity test has been made [12]. This test is more restrictive than the current USP test, especially as the batch mean deviates from target. It is also more restrictive for capsules, since both the tablets and capsules are required to meet the same requirements. A number of USP Pharmacopeial Forum articles have been written by the Pharmaceutical Manufacturers Association (PhRMA) statistics expert team discussing the proposal and their characteristics. An approved version of the proposal is eventually expected. In anticipation of this happening, appropriate modifications to the CuDAL approach have been determined to evaluate the newly proposed test.

## VI. CONCLUSIONS

A number of statistical techniques are described for possible use in the analysis of prospective process validation data of tablets and capsules, and some of their advantages and disadvantages are discussed. Detailed examples are provided to aid in the understanding of many of the techniques discussed. The authors hope that this entry will stimulate the use of the outlined statistical approaches for the analysis of validation data by industry and their acceptance by the FDA. For powder blends, industry feels compelled to use the FDA approach, as it is most likely to be accepted by the FDA. A number of other approaches, however, such as the SDPI and the CuDAL approaches, are also more constraining than the USP 25 test while providing a sound statistical basis for the development of acceptance criteria. For finished product testing of content uniformity and dissolution, the CuDAL approach offers a number of advantages that the authors believe should be considered. It is hoped that this entry will not only encourage an increase in the use of statistical techniques for the analysis of validation data but also spur discussion of the relative merits of the various techniques.

## REFERENCES

1. Blend uniformity analysis: Validation and in-process testing. technical report no. 25. *PDA J Pharm Sci Tech* (suppl.) 51 (1997).
2. Bergum, J. S. Constructing acceptance limits for multiple stage tests. *Drug Dev Ind Pharm* 16:2153–2166 (1990).
3. Hahn, G. J., Meeker, W. Q. *Statistical Intervals: A Guide for Practitioners*. New York: Wiley (1991).
4. Lindgren, B. W. *Statistical Theory*. New York: Macmillan (1968).

5. Graybill, F. A., Wang, C. M. Confidence intervals on nonnegative linear combination of variances. *J Amer Statis Assoc* 75:869–873 (1980).
6. Dietrick, J. Special forum on blend analysis. Presentation sponsored by PDA, Rockville, MD, Jan. 1996.
7. *SAS/QC Software®: Usage and Reference*. version 6, 1st ed., vol. 1. Cary, NC: SAS Institute, pp. 175–186 (1995).
8. Satterthwaite, F. E. An approximate distribution of estimates of variance components. *Biometrics* 6:110–114 (1946).
9. Nelson, L. S. The mean successive difference test. *J Qual Tech* 12:174–175 (1980).
10. FDA. *Draft Guidance for Industry ANDAs: Blend Uniformity Analysis*. Rockville, MD (Aug. 1999).
11. The Use of Stratified Sampling of Blend and Dosage Units to Demonstrate Adequacy of Mix for Powder Blends, Blend Uniformity Working Group of Product Quality Research Institute (PQRI); available at PQRI Website (<http://www.pqri.org>).
12. Pharmacopeial Forum, Harmonization, General Chapter <905> Uniformity of Dosage Units. *Pharm Forum* 2001, May–June, 27(3):2615–2619.

# 20

## Change Control and SUPAC

**Nellie Helen Waterland and Christopher C. Kowtna**

*DuPont Pharmaceuticals Co., Wilmington, Delaware, U.S.A.*

### I. INTRODUCTION

Change is inevitable in a pharmaceutical manufacturing operation. Vendors change processes, sources, and specifications for raw materials, equipment requires repair, service, or replacement, manufacturing locations are changed, batch sizes are increased or decreased, and advancements in technology are made that dictate changes to the operations. Changes made in a pharmaceutical manufacturing plant that have any potential to impact the safety, quality, purity, efficacy, or potency of a pharmaceutical preparation must be made in a way that assures these characteristics are not adversely impacted. Supporting data must be generated and appropriately reviewed; regulatory filing requirements must be considered and met; and any associated data need to be retained for the length of time the product being manufactured using the change is on the market. A written change control program in your company must account for all these aspects. Good manufacturing practice (GMP) regulations in Title 21 Code of Federal Regulations (CFR) 210 and 211 do not specifically state requirements for written change control procedures [1]. Such procedures are required by current good manufacturing practices (CGMP), however, and are included in the proposed CFR 210 and 211. This chapter will review many common industry change control practices. Readers are asked to review the practices listed and select those that best fit the needs and corporate culture of their company.

As mentioned above, the FDA also has issued SUPAC (scale up and post approval changes) guidelines that list filling and data requirements for many of the most common types of changes. In this chapter, these finalized guidelines will be reviewed to ensure a thorough understanding.

## II. CHANGE CONTROL

### A. Current Regulations

Although a written change control procedure is not currently *specifically* required in the CGMPs, having such a procedure and ensuring your company is following this procedure ensures you are prepared to deal with any changes that do occur. In addition, several 483 observations have been noted that list the lack of a written change control procedure as a deviation. As D. M. Stephon noted, if you “get it wrong” from the start, the consequences could put your company in a state of crisis management for a long time to come [2].

While CGMPs do not specify a change control program per se, there are several requirements currently included in the regulations that would lead one to develop a written control system.

#### Subpart B—Organization and Personnel

21CFR211.22(c): “The Quality Control Unit shall have the responsibility for approving or rejecting all procedures or specifications impacting on the identity, strength, quality and purity” [1].

#### Subpart F—Production and Process Controls

21CFR211.100: “written procedures for production and process control . . . These written procedures, including any changes, shall be drafted, reviewed, and approved by the appropriate organizational units” [1].

#### Subpart I—Laboratory Controls

21CFR211.160(a): “The establishment of any specifications, standards, sampling plans, test procedures, or other laboratory control mechanisms required by this subpart, including any change in such specification, standards, sampling plans, test procedures, or other laboratory control mechanisms shall be drafted by the appropriate organizational unit and reviewed and approved by the quality control unit” [1].

21CFR211.22(c) specifies the quality control units (QCU) responsibility. This section also implies a requirement for orderly control of change documentation and review and approval by the QCU at a minimum, along with any other interested functional groups. How could the processing of a change occur without designated responsibilities for the “other functional units?”

One might say that practically any procedure could impact identity, strength, quality, or purity, yet these procedures are the responsibility of one or more functional groups in addition to the QCU. For example, the manufacturing formula is the prime responsibility of technical services or manufacturing (or both), but changes to a manufacturing formula may require review and approval of other “interested functional groups” as follows:

Packaging for input on the volume in the container

Stability for impact on product specifications profile over time

Other plants making the “same” product

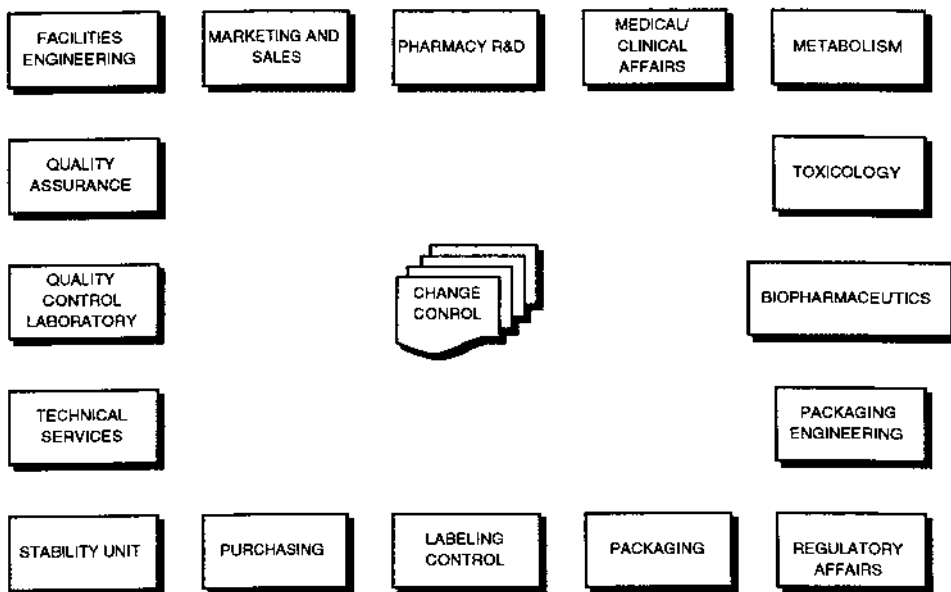
QC laboratory to assess the impact on testing methodology, etc.  
 Purchasing for impact on vendor sources (e.g., new dye)  
 Marketing for impact on the market image  
 Regulatory affairs for impact on filings worldwide

21CFR211.100 specifically requires review and approval by appropriate organizational units. This is clear, and surely fits in with the practicalities previously mentioned. Another example, 21CFR211.160, is also very clear. Here too, organizational units or functional groups are required to review and approve changes.

Figure 1 outlines some of the functional groups that have input on the necessity and reasonableness of changes in manufacturing drug products. This list should be expanded as appropriate and made specific for your company. The point is that most often many groups are impacted and should have the option of being heard regarding that impact.

## B. Proposed Regulations

The FDA's May 3, 1996, proposal for revision of the CGMPs clearly recognizes the importance of change control. The proposed revision [21 CFR211.22(a)] would make the quality unit "responsible for the review and approval of valida-



**Figure 1** Functional groups involved in change control.

tion protocols and for the review of changes in product, process, equipment, or other changes to determine if and when revalidation is warranted” [3].

Of course this is not a retrospective review. Ideally, changes are initially proposed for consideration. This makes sense from a business perspective, as the proposal could impact time, effort, and money, not to mention the fact that the proposed change needs to maintain or increase quality, safety, purity, and so on. Control of changes, prospective review of rationale, planned regulatory assessment, validation, and so forth is extremely important from both a business and a government standpoint. Once a facility, process, product, equipment, lab procedure, and so on is established, any changes should be evaluated prior to being implemented. Current CGMPs require such an evaluation, and change control is the term for that activity.

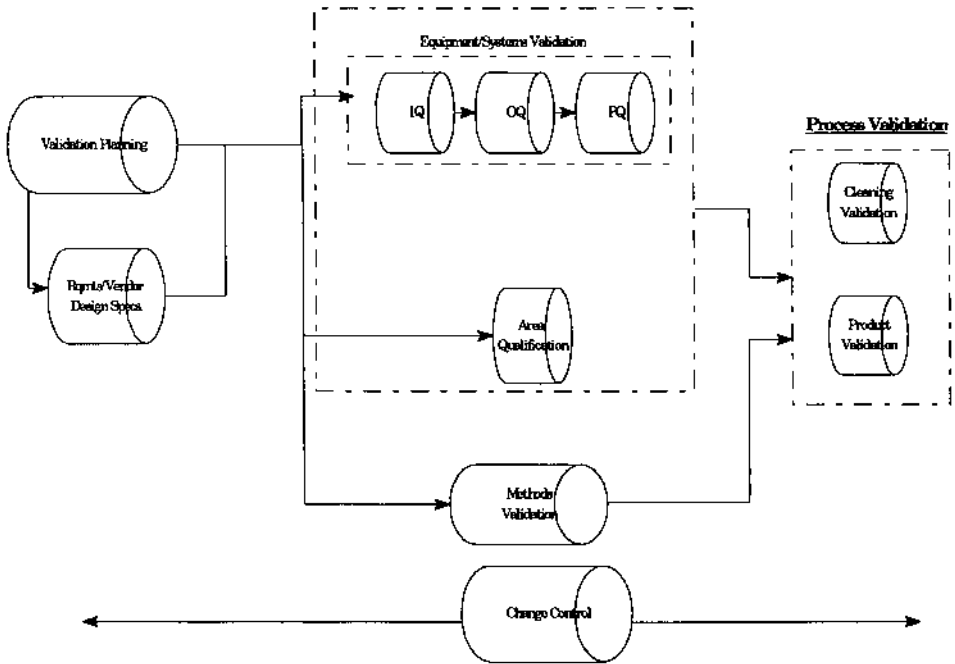
### **C. Goal**

So far we have discussed change control in general terms. We will now consider the specific goal of change control.

An up and running manufacturing operation has been commissioned, qualified, validated, and certified to produce satisfactory product in accordance with internal requirements and external CGMP regulations. Change is inevitable, and when changes are proposed they must be assessed as to the impact on the steady state system, as noted in [Figure 2](#). It is the change control process that assures continuous quality. It identifies the concerns or nonobjections of all responsible functional groups, assuring the proper evaluation, once the testing and continuity of the change across all systems, procedures, and documents for that product or dosage everywhere it is made. This orderly control of change assures consistent conformance to identified requirements by assuring everyone’s input.

This is a commonsense argument for change control, not only because the product we produce is pharmaceutical, but also because change control applies to other industries as well, including airlines, automotive, and electronics. As a matter of fact, many industries have this requirement, and where they do not, they are looking for ways to implement it. The ISO series and Six Sigma are two examples of current quality and business improvement initiatives, which both improve the processes involved and implement change control to keep the process consistent.

You might remember the catastrophe that occurred in the late 1970s when an engine on a large commercial aircraft fell to the ground upon takeoff at Chicago’s O’Hare Airport. All passengers and crew were killed, as were two persons on the ground. Ensuing investigation indicated the cause was “maintenance induced damage leading to the separation of the number one engine and pylon assembly at a critical point during takeoff . . . The separation resulted from damage from an improper maintenance procedure which led to failure of



**Figure 2** Change control continuum.

the pylon structure . . . the probable cause was a fatigued engine mounting bolt. Contributing to the cause of the accident” included “deficiencies in the practices and communications among the operators, the manufacturer . . . and the intolerance of prescribed operational procedures to this unique emergency” [4].

The change in maintenance procedure was developed and implemented without the review and approval of the aircraft manufacturer responsible for the original maintenance procedure. One wonders if the accident could have been avoided if the developers of the change obtained the manufacturer’s approval before implementing it. Had they done so, the problems with the change may have been identified and the change may have been rejected or refined.

A change control system should require input where appropriate from the original research and design groups to assure that all possible aspects and potential impact are fully reviewed.

The goal of change control is a systematic process by which every change is evaluated by appropriate personnel from appropriate functional groups for impact from a quality, safety, and regulatory standpoint before it is imple-

mented. Change control identifies all documents and procedures impacted by the change, as well as all testing necessary to assess the suitability of the proposed change before implementation. Evaluation is conducted by the quality unit and all other functional groups impacted or having the knowledge needed to perform an adequate assessment.

## **D. What a Change Control Procedure Should Contain**

### **1. Objective or Purpose**

The objective or purpose of change control should be stated in clear terms. An example of this statement is

A process that provides a mechanism for evaluation of a change against approved and/or validated conditions. This evaluation must be satisfied prior to implementation of the change in the GMP-related aspects of our business.

### **2. Scope**

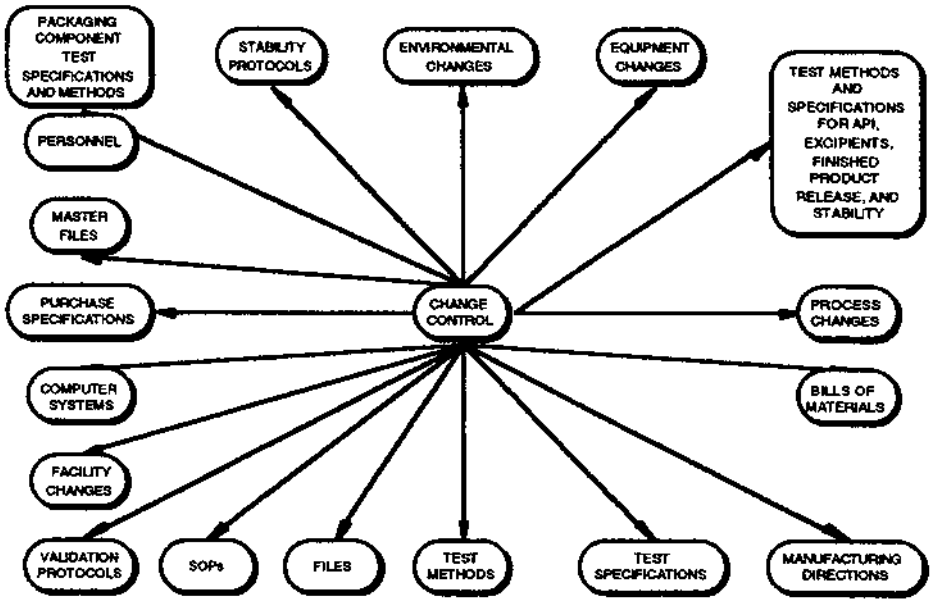
The scope should define the applicability of change control from a national or international (global) standpoint. Applicability of the change control procedure internally and where appropriate externally should be completely defined.

[Figure 3](#) gives some examples of items that should fall under the change control umbrella.

### **3. Process Flow**

The change control process is a simple process, as shown in [Figure 4](#). Although all employees should be encouraged to propose a change, only those individuals who can formally initiate a change (i.e., take the initial proposal and formally initiate the change control process) should be identified as having that responsibility. The informal review by the functional group responsible (the “owner”) for the document, system, or procedure(s) being changed should review the proposal informally and assign an initiator to the change before all the other functional groups are asked to review it. The initiator then generates the formal proposal. This proposal should list the change completely and accurately, including the planned or completed work to validate and/or qualify the change, along with a time line to complete the work and the proposed implementation date. The process is changed, validated, or qualified, and a final assessment report drafted, reviewed, and approved by all appropriate functional units and the quality unit. Once the change is approved in this manner, the change control process is completed, and if no impact on existing regulatory filings has been determined by the regulatory affairs unit, the change may be implemented. If





**Figure 3** Change control is an interactive process involved with all functions.

the change is determined to impact filings, the company may have to wait until the necessary filings are made, and where required, approved by the regulatory agencies.

Functional groups involved in change control should understand their scope of responsibility. Where necessary, a responsibility matrix, as shown in [Figure 5](#), should be developed for your company. This responsibility matrix can be included in your change control procedure.

### III. SUPAC

#### A. History and Philosophy of SUPAC

The question “How can we update or change the information in an approved application?” is often asked. The answer varies (the batch sizes needs to change, there are new methodologies and specifications developed, we want to manufacture and test at a different site, etc.). These changes are called “postapproval changes” (PACs) because they effect applications that have already been approved.

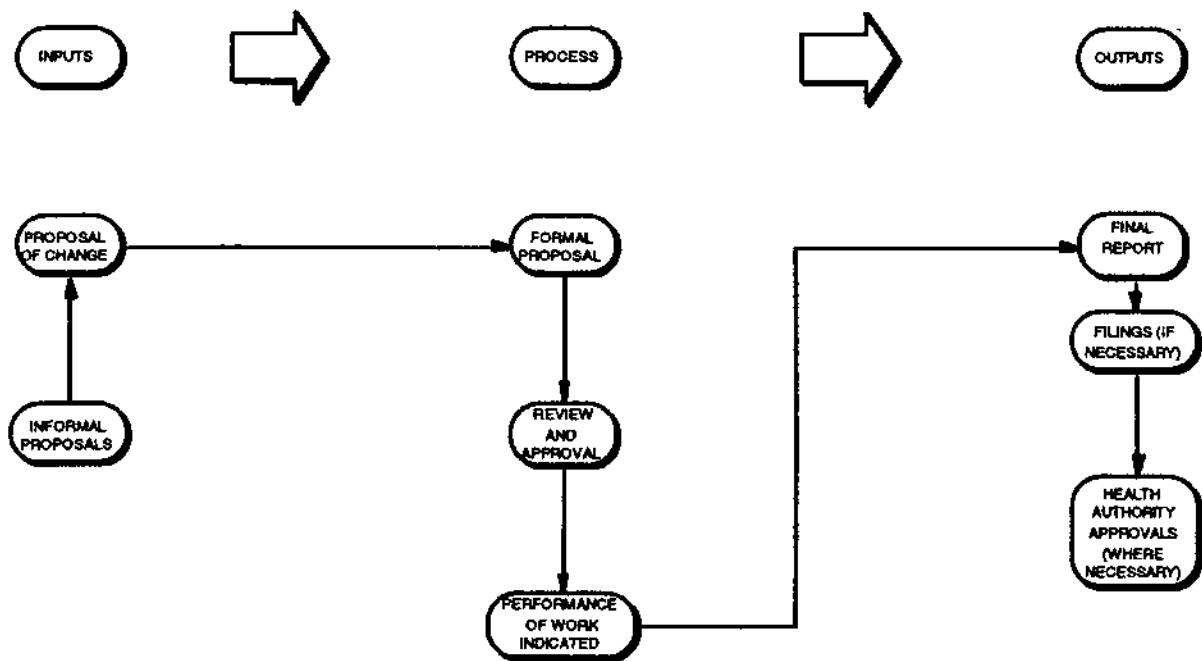


Figure 4 Process for change control.

	Initiation of Change Control	Proofreading	Conformance to CGMP and Applicability to Other Systems	Review and Approval	Regulatory Impact and Worldwide Filing Strategy	Validation
Quality Assurance						
Quality Control						
Manufacturing						
Process Engineering						
Technical Services						
Regulatory Affairs						
Owner of System or Procedure Being Changed						

**Figure 5** Functional group responsibilities.

These changes were addressed in the regulations and have evolved over time (1962–1974, 1974–1985, 1985–1999). These three sets of regulations defined and handled PACs in different ways. Even with these regulations, historically the FDA has had difficulty developing a regulatory policy for many PACs that both FDA reviewers and the regulated industry could easily interpret. A new policy was needed and it needed to be based on sound scientific principles. As a result, several initiatives were begun to develop the necessary scientific foundation. The American Association of Pharmaceutical Scientists (AAPA) offered to assist the FDA in compiling the information necessary to support scale-up/scale-down of solid oral dosage forms [5]. In April 1990 the FDA accepted, resulting in a workshop sponsored by the FDA, the U.S. Pharmacopeial Conven-

tion, and AAPS. Under the FDA/University of Maryland manufacturing research contract the University of Maryland in Baltimore conducted research on the chemistry, manufacture, and controls of immediate release drug products. Research on drug categorization was conducted at the University of Michigan, and the University of Uppsala conducted research on the permeability of drug substances.

In April of 1995, the president made a commitment in the National Performance Report, "Reinventing Drug and Medical Device Regulations," that the number of manufacturing changes requiring preapproval by the FDA would be reduced. The FDA, with the results of this workshop and research, was well prepared for this commitment. Consequently, the SUPAC task force, established by the Center for Drug Evaluation and Research Chemistry manufacturing and controls coordinating committee, was able to develop the SUPAC-IR (immediate release oral solid dosage forms) guidance, which was issued in November of 1995 [6]. It should be noted that the SUPAC documents were not the FDA's first attempt to provide guidance on scale-up of batch sizes. The FDA has historically had difficulty developing a policy on scaling up to commercial batch sizes from submission batch sizes in the application for oral solid dosage forms. This need resulted in FDA guideline 22-90 and the provision for 10× increase implementation based on obtaining "similar" dissolution profiles and allowance for submission of biobatch sizes of 10% of the proposed commercial batch size. This guideline did not address, however, the possibility of necessary composition or equipment changes that may be required to scale up. SUPAC-IR provides guidance on the necessary data and filing requirements for these changes.

The SUPAC-IR guidance and the PAC guidances that followed describe three classifications of PACs requiring different levels of chemistry manufacturing and control changes that may be made, the *in vitro* dissolution tests and/or *in vivo* bioequivalence tests for each level of change, and the filing documentation necessary. This information was given for changes in the components and composition of the drug, site of manufacture, scale-up or scale-down of a process, and manufacturing process and equipment changes. It should be noted that when first issued, the SUPAC guidances stated that only one change was to be made at a time via SUPAC. Since its first issue, however, the FDA has realized that many individual changes involve other more "minor" changes. Consequently, more than one change may be made at the same time under SUPAC, as long as the following conditions are met: (1) the changes to be made are discussed with the FDA reviewing division before they are made, and (2) the most onerous filing route is chosen. (If one change requires an annual report filing and another change requires a prior approval filing, both may be filed as prior approval changes.) All documentation noted for all changes being made should be included in the filing.

In November of 1996, the president signed into law the Food and Drug

Association Modernization Act (FDAMA). Among other provisions it was mandated that within 3 years the regulations that included 21CFR314.70 (changes to an approved application) would cease to exist. In June of 1999, the FDA issued a draft regulation and accompanying draft guidance to address this impending deletion. Although the regulation was not made effective before the November 20 deadline, the FDA finalized the guidance in November 1999 (published in the *Federal Register* of November 23, 1999). This guidance addressed changes in components and composition, manufacturing sites, manufacturing process, specifications, packaging, labeling, miscellaneous changes, and multiple related changes. Although the November 1999 guidance discusses changes covered in the SUPAC guidances, it does not provide extensive recommendations on reporting categories and filing requirements for component and composition changes. As a result, the November 1999 guidance clearly states that “recommended reporting categories for component and composition changes provided in previously published guidances, such as the SUPAC guidances, still apply” [7].

Many times when reviewing the content of the SUPAC guidances the question arises regarding the use of the guidance for prior approval supplements. Since the change was a prior approval change before the SUPAC guidances, what does this guidance do for us? Before the SUPAC guidances, different FDA chemistry reviewers could look at the same change and request vastly different information, depending upon their individual area of specialty. It was frequently difficult to predict what filing documentation would be necessary for any individual reviewer. To compound this problem, if reviewers changed during the review of a supplement, the new reviewer frequently requested additional information to support the change, resulting in additional review time. With the SUPAC guidances, it is now clear what data are required to be submitted for each type of listed change, alleviating this problem.

## **B. Current Finalized SUPACs**

### **1. SUPAC-IR (November 1995)**

As mentioned above, in November of 1995, the FDA issued the first of its SUPAC guidances. This guidance addressed scale-up and PACs for immediate release oral solid dosage forms, the most common dosage form. This guidance should be reviewed prior to determining the regulatory filing requirements for any changes in manufacturing immediate release oral solid dosage forms that have any possibility of impacting the U.S. new drug application or abbreviated new drug application.

When making equipment changes, the FDA’s SUPAC-IR/MR Immediate Release and Modified Release Solid Oral Dosage Forms Manufacturing Equip-

ment Addendum, released in January of 1999 should be consulted to determine what is considered equipment of the “same design and operating principal” and what is considered equipment of “different design and different operating principal” [8]. This addendum lists various types and pieces of equipment and categorizes them into operating classes and subclasses.

In general, level 1 changes may be filed in an annual report and are deemed unlikely to have any detectable impact on formulation quality or performance. Level 2 changes could have a significant impact on formulation quality and performance, and are thus either filed in a changes being effected (CBE) supplement or a prior approval (PA) supplement. Level 2 tests and filing depend on therapeutic range (narrow or not narrow [8]), Solubility [8] (high or low), and permeability [8] (high or low). Level 3 changes are likely to have a significant impact on Rx quality and performance, and are thus always filed in PA supplements. Level 3 tests and filing documentation vary, depending on the therapeutic range, solubility, and permeability of the pharmaceutical product.

All of the SUPAC documents provide for changes in levels of excipients. The regulatory impact of these excipient changes (annual report, CBE, or PA submission) is dependent upon the quantity of the change in excipients in the approved formulation. For example, your approved formulation consists of 15% lactose and 20% methylcellulose. If you want to change this to 10% lactose and 25% methylcellulose, the total excipient change is 10% (5% decrease in lactose plus a 5% increase in methylcellulose). If the finished product were an IR formulation, this would be a level 2 change requiring a prior approval supplement. Details of this guidance may be found in [Table 1](#).

## 2. SUPAC-IR Questions and Answers (February 1997)

In February 1997, the FDA issued a letter containing the most frequently asked questions regarding SUPAC. The first clarification contained a response to questions from industry regarding a stand-alone packaging site change. (See [Table 2](#) for details regarding this response.)

The second change referred to postapproval analytical testing site changes. In February of 1997, “SUPAC-IR Questions and Answers” responded to this concern. This response only addresses SUPAC-IR, however. In April 1998, the FDA issued a guidance entitled “PAC-ATLS: Post Approval Changes—Analytical Testing Laboratory Sites.” This guidance covered analytical testing site changes for all dosage forms.

## 3. PAC-ATLS (April 1998)

In April 1998 the FDA issued the PAC-ATLS (postapproval changes—analytical testing laboratory site) guidance document allowing analytical testing laboratory site changes for all regulated dosage forms [9]. Prior to this date, only dosage

**Table 1** SUPAC-IR

	Level 1	Level 2	Level 3
Components and composition			
Example	Deletion or partial deletion of ingredient → color, flavor, or ink. Changes in excipients as % (w/w) of total ≤ specified ranges <sup>a</sup> Filler ±5 Disintegrant Starch ±3 Other ±1 Binder ±0.5 Lubricant Ca or Mg stearate ±0.25 Other ±1 Glidant Talc ±1 Other ±0.1 Film coat ±1 Note: total NGT 5%	Change in technical grade of excipient (Avicel 102 vs. 200) Change in excipients as % w/w total formulation <sup>b</sup> GT level 1 but LT 2× level 1 Filler ±10 Disintegrant Starch ±6 Other ± Binder ±1 Lubricant Ca or Mg stearate ±0.5 Other ±2 Glidant Talc ±2 Other ±0.2 Film coat ±2	Any quality/quantity excipient changes to NTD and beyond ranges in level 1 All other drugs not meeting the dissolution cases under level 2 Changes in the excipient ranges of LS/LP drugs beyond Changes in excipient ranges of all drugs beyond 2× level 1

*(continued)*

**Table 1** *Continued*

	Level 1	Level 2	Level 3
Test documenta- tion chemistry documentation	Application/compendial release requirements and stability testing Stability 1 batch long-term data in annual report	Application/compendial release requirements and batch records Stability testing—one batch, 3-mo. acc. in supplement & one batch on long-term stability	Application/compendial release requirements and batch records Significant body of info <sup>a</sup> available: One batch 3 mo. are in supplement One batch long-term stability in AR Significant body of info <sup>c</sup> not available Up to three batches with 3-mo. acc in supplement Up to three batches long-term stability in AR
Dissolution document	None beyond app./compendial requirements	Case A: HP/HS. 85% in 15 min in 900 ml 0.1 N HCl <sup>d</sup> Case B: LP/HS. Multipoint dissolution profile in app./compendial medium at 15, 30, 45, 60, 120 min or to asymptote profile of proposed and current Rx should be similar. Case C: HP/LS. Multipoint in H <sub>2</sub> O, 0.1 N HCl and USP buffer media at 4.5, 6.5, and 7.5 (five separate profiles) for proposed and current Rx; 15, 30, 45, 60, 120 until either 90% or asymptote. Both should be similar. <sup>e</sup>	Case B profile under level 2



In vivo bioequivalence	None	None. If do not meet case A, B, or C, go to level 3.	Full bio study <sup>f</sup>
Filing	AR includes all documents and stability data	Prior approval supplement. All info includes accelerated data. Annual report to include long-term data.	Prior approval supplement documents and acc data AR-LT data
Manufacturing changes process			
Example	Includes such process changes as mixing times and operating speeds within application/validation ranges	Includes such process changes as mixing times and operating speeds outside application/validation ranges	Includes change in the type of process used in the manufacture of the drug product, such as a change from wet granulation to direct compression of dry powder
Test documentation chemistry documentation	None beyond application/compendial release requirements	Application/compendial release requirements Notification of change and submission of updated batch records One batch LT stability	Appl/compd. release requirements Notification of change and submission of updated batch records Stability/significant body of info A One batch 3 mo. acc in supplement One batch LT stability in AR Significant body of info N/A Up to three batches acc in suppl. Up to three batches LT stability in AR
Dissolution documents	None beyond application/compendial release requirements	Class B profile <sup>g</sup>	Case B profile
In vivo bioequivalence	None	None	In vivo bioeq required <sup>h</sup>
Filing	AR	CBE supplement AR-LT Stability	PA Suppl with justification AR-LT stability

(continued)

**Table 1** *Continued*

	Level 1	Level 2	Level 3
Manufacturing changes <sup>i</sup> equipment			
Example	Change from nonauto/nonmech. to auto or mech. equipment to move ingredients Change to alternative equipment of same design and operating principles <sup>j</sup> of the same or different capacity <sup>k</sup>	Change in equipment to a different design and different operating conditions	None defined
Test documentation chemistry documentation	Application/compendial release requirements Notification of change and submission of updated batch records Stability one batch LT	Application/compendial release requirements Notification of change and submission of updated batch records Stability test Significant body of info <sup>l</sup> One batch 3 mo. acc report in suppl. One batch LT stability in AR Significant body of info N/A <sup>l</sup> Up to three batches acc in suppl Up to three batches LT in AR	

Dissolution documents	None beyond application/com-pendial release requirements	Case C dissolution Multipoint dissolution profiles in water, 0.1N HCl, and USP buffer media at pH 4.5, 6.5, and 7.5 (five separate pro-files) for the proposed and currently accepted formula-tions. Adequate sampling should be performed at 15, 30, 45, 60, and 120 min until either 90% dissolved or as-ymptote is reached. A surfac-tant may be used with appro-priate justification.	
In vivo bioequi-valence	None	None	
Filing	AR LT stability data	PA suppl. with justification for change LT stability in AR	
Site changes <sup>m</sup> Example	Site changes within a single fa-cility where same equipment, SOPs, environmental condi-tions and controls, and person-nel common to both manufac-turing sites are used; no changes are made to manufac-turing batch records, except administrative info, and loca-tion of the facility. Common is defined as employees al-ready working on the campus who have suitable experience in the manufacturing process.	Site changes within a contigu-ous campus, or between facili-ties in adjacent city blocks, where same equipment, SOPs, environmental condi-tions and controls, and person-nel common to batch manu-facturing sites are used and where no changes are made to the manufacturing batch re-cords except for administra-tive information and location of the facility.	Consist of a change in manufacturing sites to different campus <sup>n</sup> To qualify: same equipment, SOPs, envi-ronmental conditions and controls should be used in the manufacturing process at the new site, and no changes may be made to the manufacturing batch records except for administrative info, location, and language translation, where needed.

(continued)  
747

**Table 1** *Continued*

	Level 1	Level 2	Level 3
Test documentation chemistry documentation	None beyond application/compendial release requirements	Location of new site and updated batch records; none beyond application/compendial release requirements One LT batch on stability report in AR	Location of new site and updated batch records Stability: <i>Significant body of info available</i> <sup>o</sup> One batch 3-mo. acc in suppl. One batch on LT stability in AR Stability: <i>Significant body of info not available</i> <sup>o</sup> Up to three batches with 3-mo. acc in Suppl. Up to three batches on LT stability in AR
Dissolution documents	None beyond application/compendial release requirements	None beyond application/compendial release requirements	Case B multipoint dissolution profile in appl./compd. medium at 15, 30, 45, 60, and 120 min or until asymptote reached. Dissolution profile of drug product at current and proposed site should be similar.
In vivo bioequivalence	None	None	None
Filing	Annual report	CBE suppl. AR LT stability data.	CBE suppl. AR LT stability data

Changes in batch size<sup>p</sup>

Example

Change in batch size, up to and including a factor of 10× the size of the pilot/biobatch where  
 Equipment used to produce the test batch(es) is of the same design and operating principles.  
 The batch(es) is (are) manufactured in full compliance with CGMPs.  
 The same SOPs and controls as well as the same formulation and manufacturing procedures are used on the test batch(es) and on the full-scale production batch(es).

Change in batch size, beyond 10× size of the pilot/biobatch where  
 Equipment used to produce test batches is of the same design and operating principles.  
 The batch(es) is (are) manufactured in full compliance with CGMPs.  
 The same SOPs and controls as well as the same Rx and manufacturing procedures are used on the test batch(es) and on the full-scale production batch(es).

None defined

Test documentation chemistry documentation

Application/compendial release requirements  
 Notification of change and submission of updated batch records in AR  
 One batch LT stability in AR

Application/compendial release requirements  
 Notification of change and submission of updated batch records  
 One batch with 3 mo. acc.; one batch LT stability

*(continued)*

**Table 1** *Continued*

	Level 1	Level 2	Level 3
Dissolution documents	None beyond application/compendial release requirements	Case B testing Multipoint dissolution profile in application/compendial medium at 15, 30, 45, 60, and 120 min or until an asymptote is reached for the proposed and currently accepted formulations	
In vivo bioequivalence	None	None	
Filing	AR LT stability	CBE suppl ARLT stability data	

<sup>a</sup> Based on assumption that the drug substance in the drug product is formulated to 100% of label/potency. The total additive effect of all excipient changes should not be more than 5%. Allowable changes in the composition should be based on the approved target composition and not on previous level 1 changes in the composition.

<sup>b</sup> Based on assumption that the drug substance in the drug product is formulated to 100% of label/potency. Total additive effect of all changes NGT 10%. Allowable changes in composition should be based on the approved target composition and not on the composition based on previous level 1 or level 2 changes.

<sup>c</sup> Significant body of information on the stability of the drug product is likely to exist after 5 years of commercial experience for NME's or 3 years of commercial experience for new dosage forms.

- <sup>d</sup> Using USP <711> apparatus 1 at 100 rpm or apparatus 2 at 50 rpm.
- <sup>e</sup> A surfactant may be used with appropriate justification.
- <sup>f</sup> The bioequivalence study may be waived when an acceptable in vivo/in vitro correlation has been verified.
- <sup>g</sup> Multipoint dissolution profile in application/compendium medium at 15, 30, 45, 60, 120 min or to asymptote. Profile of proposed and current Rx should be similar.
- <sup>h</sup> May be waived if a suitable in vivo/in vitro correlation has been verified.
- <sup>i</sup> Changes may affect both equipment used in the manufacturing process and the process itself.
- <sup>j</sup> Agreeing in kind, amount; unchanged in character or condition. See SUPAC-IR/MR Immediate Release and Modified Release Solid Oral Dosage Forms Manufacturing Equipment Addendum (Jan. 1999).
- <sup>k</sup> Rules or concepts governing the operation of the system.
- <sup>l</sup> Significant body of information on the stability of the drug product is likely to exist after 5 years of commercial experience for NMEs or 3 years of commercial experience for new dosage form.
- <sup>m</sup> Consist of changes in location of the site of manufacture for both company-owned and contract manufacturing facilities and not include scale-up changes, changes in manufacturing (including process and/or equipment), or changes in components or composition. New manufacturing location should have a satisfactory CGMP inspection.
- <sup>n</sup> Different campus—one that is not on the same original contiguous site or where the facilities are not on adjacent city blocks.
- <sup>o</sup> Significant body of information on the stability of the drug product is likely to exist after 5 years of commercial experience for NMEs or 3 years of commercial experience for new dosage form.
- <sup>p</sup> Postapproval changes in the size of a batch from the pivotal/pilot scale biobatch materials to larger or smaller production batches call for submission of additional information in the application. Scale down below 100,000 dosage units is not covered by this guideline. All scale-up changes should be properly validated and where needed, inspected by appropriate agency personnel.

**Table 2** SUPAC-IR Questions and Answers: Stand-Alone Packaging Site Changes

---

Example	Stand-alone site change utilizing container(s)/closure(s) in approved application. Facility has a current CGMP compliance profile with FDA for the type of packaging operation before submitting the supplement.
Test documentation chemistry documentation	Written certification from packaging facility stating that it is in conformance with CGMPs. Commitment to place first production batch of production LT/RT studies using the approved protocol <sup>a</sup> in the application. Submit data in annual reports. More than one strength, size, or C/C system. One batch of each combination on LT/R in accord with approved protocol. <sup>a</sup>
Dissolution documents	None beyond NDA/compendial requirements.
In vivo bioequivalence	None
Filing	CBE supplement (CBE), annual report, long-term/room temperature stability

---

*Note:* FDA letter 2/18/97 revises SUPAC-IR to allow stand-alone packaging site changes for IR solid oral dosage forms as a CBE. Previously packaging site changes had to be part of a CBE manufacturing site change or be a prior approval supplement.

<sup>a</sup>Any changes to an approved stability protocol should have a supplemental approval prior to initiation of the stability study.

forms covered in SUPAC-IR, MR, and SS were allowed to make analytical testing laboratory site changes under SUPAC. This was allowed for SUPAC-IR through an FDA letter to industry containing frequently asked SUPAC questions and answers. Details regarding this guidance may be located in [Table 3](#).

#### 4. SUPAC MR (September 1997)

In September of 1997, the FDA issued another SUPAC guidance for solid oral dosage forms. This new guidance addressed changes to modified release dosage forms, such as extended release and delayed release forms. As with the SUPAC-IR guidance, this new guidance addressed common changes in components and composition. The MR guidance broke these changes down into nonrelease controlling excipients and release controlling excipients, however. The SUPAC-MR guidance also addresses site changes, changes in batch size, manufacturing equipment changes, and manufacturing process changes.

As with the SUPAC-IR guidance, when making equipment changes, the FDA's SUPAC-IR/MR Immediate Release and Modified Release Solid Oral Dosage Forms Manufacturing Equipment Addendum, released in January of



**Table 3** PAC-ATLS: Stand-Alone Analytical Testing Laboratory Site Changes

---

Example	A stand-alone analytical laboratory site change if new facility has a current and satisfactory CGMP compliance profile for the type of testing operation in question A change from a contract analytical laboratory to your company analytical laboratory A change from one contract laboratory to another A change from your company analytical laboratory to a contract laboratory
Test and chemistry documentation	Commitment to use the same SOPs and test methods employed in the approved application; written certification from the testing laboratory stating that it is in conformance to CGMPs and a full description of the testing to be performed by the testing laboratory
Filing	CBE with full description and certification

---

*Note:* April 1998, the FDA issued the guidance PAC-ATLS. Prior to that time, an 2/18/97 FDA letter revises SUPAC IR to allow Stand-Alone Analytical Testing Lab. Site Changes for IR. Solid Oral Dosage forms as a CBE. Previously analytical testing lab. site changes had to be part of a CBE manufacturing site change or be a prior approval supplement.

1999, should be consulted to determine what is considered equipment of the “same design and operating principle” and what is considered equipment of “different design and different operating principle” [8]. This addendum lists various types and pieces of equipment and categorizes them into operating classes and subclasses.

Similar to SUPAC-IR, level 1 changes are unlikely to have any detectable impact on formulation quality or performance, and are consequently annual reportable changes. Level 2 changes could have a significant impact on formulation quality and performance, and are thus either CBE supplements or PA supplements. For a nonrelease controlling excipient, level 2 tests and filing depend on whether the product is extended release or delayed release. For a release controlling excipient, tests and filing are dependent upon the therapeutic range of the product (narrow or not narrow). Level 3 changes are likely to have a significant impact on Rx quality and performance and are therefore “prior approval” changes. Tests and filing documentation vary, depending on whether the finished product is extended release or delayed release. Details of this guidance may be found in [Table 4](#).

## 5. SUPAC SS (May 1997)

Changes in nonsterile semisolid dosage forms should be reviewed against the November 1999 FDA guidance for industry “Changes to an Approved NDA or ANDA” and the SUPAC Guidance for Industry “Nonsterile Semisolid Dosage

**Table 4** SUPAC MR (Modified Release Oral Solid Dosage Forms)

	Level 1	Level 2	Level 3
Components and composition— nonrelease controlling excipient <sup>a</sup>			
Example	<p>Deletion or partial deletion of ingredient → color, flavor, or ink</p> <p>Changes in excipients as % (w/w) of total ≤ specified ranges<sup>b</sup></p> <p>Filler ±5</p> <p>Disintegrant</p> <p>    Starch ±3</p> <p>    Other ±1</p> <p>Binder ±0.5</p> <p>Lubricant</p> <p>    Ca or Mg stearate ±0.25</p> <p>    Other</p> <p>Glidant</p> <p>    Talc ±1</p> <p>    Other ±0.1</p> <p>Film coat ±1</p> <p>Note: total NGT ±5</p>	<p>Change in technical grade of excipient (Avicel 102 vs. 200)</p> <p>Change in excipients as % w/w total formulation<sup>c</sup> (&gt;level 1 and &lt;2 times level 1)</p> <p>Filler ±10</p> <p>Disintegrant</p> <p>    Starch ±6</p> <p>    Other ±2</p> <p>Binder ±1</p> <p>Lubricant</p> <p>    Ca or Mg stearate ±0.5</p> <p>    Other ±2</p> <p>Glidant</p> <p>    Talc ±2</p> <p>    Other ±0.2</p> <p>Film coat ±2</p>	<p>Changes in excipient ranges of all drugs beyond 2× level. Total weight of dosage form within or outside approved original application range.</p>
Test documentation chemistry documentation	<p>Application/compendial release requirements and stability testing</p> <p>Stability one batch long-term data in annual report</p>	<p>Application/compendial release requirements and batch records</p> <p>Stability testing—one batch, 3 mo. accelerated in supplement and one batch on long-term stability. (Data submitted in annual reports.)</p>	<p>Application/compendial release requirements and executed batch records</p> <p><i>Significant body of information<sup>d</sup> available:</i></p> <p>One batch 3 mo. in supplement</p> <p>First three production batches long-term stability in AR.</p>

Dissolution documents	None beyond application/compendial requirements	<p><i>Extended release product:</i> Application/compendial release requirements plus multipoint dissolution profile in three other media (e.g., water, 0.1N HCl, and USP buffer media at pH 4.5 and 6.8)</p> <p><i>Delayed release drug product:</i> In application/compendial release requirements plus dissolution tests in 0.1N HCl for 2 hr (acid stage) followed by testing in USP buffer media (pH 4.5–7.5) under application/compendia test conditions and two additional agitation speeds. Application/compendial method may be either apparatus 1 or apparatus 2.<sup>c</sup> Adequate sampling should be performed (15, 30, 45, 60, and 120 min until either 80% of drug is released or asymptote is reached). Testing should be performed on changed product and biobatch or marketed product.</p> <p><i>In vitro/in vivo correlation established:</i> Only application/compendial dissolution testing is necessary.</p>	<p>Significant body of info<sup>b</sup> not available.</p> <p>Three batches with 3 mo. accelerated data in supplement</p> <p><i>Extended release product:</i> Application/compendial release requirements plus multipoint dissolution profile in application/compendial medium for the changed drug product and the biobatch or marketed batch (unchanged drug product). Adequate sampling should be performed (1, 2, and 4 hr and every 2 hr thereafter until either 80% of drug is released or asymptote is reached).</p> <p><i>Delayed release product:</i> Application/compendial release requirements plus multipoint dissolution profile should be obtained during the buffer stage of testing using the application/compendial medium for the changed drug and the biobatch or marketed product. Adequate sampling should be performed (15, 30, 45, 60, and 120 min until either 80% of the drug is released or asymptote is reached).</p>
-----------------------	---	---	---

(continued)

**Table 4** *Continued*

	Level 1	Level 2	Level 3
In vivo bioequivalence	None	None	Single-dose bioequivalence study <sup>f</sup>
Filing	AR includes all documentation and long-term stability data	Prior approval supplement. All information, including accelerated stability data. Annual report to include long-term data.	<i>Prior approval supplement</i> all documentation and accelerated stability data <i>Annual Report</i> —long-term stability data
Components and composition—release controlling excipient			
Example	Changes in release controlling excipient(s), expressed as percentage (w/w) or total release controlling excipient(s) in the formulation $\leq 5\%$ w/w of total release controlling excipient content in the original application range	Change in technical grade of release controlling Change in release controlling excipients as % w/w total formulation <sup>g</sup> ( $>$ level 1 and $<$ 2 times level 1). The total weight of the dosage form could still be within or outside the approved original application range.	Addition or deletion of release controlling excipient(s) Changes in excipient ranges of all drugs greater than 10% (greater than those listed for level 2 changes); total weight of dosage form within or outside approved original application range
Test documentation chemistry documentation	Application/compendial release requirements and stability testing Stability one batch long-term data annual report	Application/compendial release requirements and updated executed batch records Stability testing Nonnarrow therapeutic range drugs: one batch, 3 mo. accelerated in supplement and one batch on long-term stability (data submitted in annual reports).	Application/compendial release requirements and executed batch records Stability Three batches with 3 mo. accelerated data in supplement First three production batch long-term stability in AR

Dissolution documents	None beyond application/compendial requirements	<p>Narrow therapeutic range drugs: three batches with 3 mo. accelerated stability data reported in prior approval supplement and long-term stability data of first three production batches in annual report.</p> <p><i>Nonnarrow therapeutic range drugs:</i> See level 2 dissolution requirements for nonrelease controlling excipients.</p> <p><i>Narrow therapeutic range drugs</i></p> <p><i>Extended release product:</i> Application/compendial release requirements plus multipoint dissolution profile in application/compendial medium for the changed drug product and the biobatch or marketed batch (unchanged drug product). Adequate sampling should be performed (1, 2, and 4 hr and every 2 hr thereafter until either 80% of drug is released or asymptote is reached).</p> <p><i>Delayed release product:</i> Application/compendial release requirements plus multipoint dissolution profile should be</p>	<p><i>Extended release product:</i> Application/compendial release requirements plus multipoint dissolution profile in application/compendial medium for the changed drug product and the biobatch or marketed batch (unchanged drug product). Adequate sampling should be performed (1, 2, and 4 hr and every 2 hr thereafter until either 80% of drug is released or asymptote is reached).</p> <p><i>Delayed release product:</i> Application/compendial release requirements plus multipoint dissolution profile should be obtained during the buffer stage of testing using the application/compendial medium for the changed drug and the biobatch or marketed product. Adequate sampling should be performed (15, 30, 45, 60,</p>
-----------------------	---	--	--

(continued)

**Table 4** *Continued*

	Level 1	Level 2	Level 3
		obtained during the buffer stage of testing using the application/compendial medium for the changed drug and the bio-batch or marketed product. Adequate sampling should be performed (15, 30, 45, 60, and 120, min until either 80% of the drug is released or asymptote is reached).	and 120 min until either 80% of the drug is released or asymptote is reached).
In vivo bioequivalence	None	<p><i>In vitro/in vivo correlation established:</i> Only application/compendial dissolution testing is necessary.</p> <p><i>Nonnarrow therapeutic range drugs:</i> None</p> <p><i>Narrow therapeutic range drugs:</i> Single-dose bioequivalence study. This study may be waived if in vitro/in vivo correlation is established. Changes in release controlling excipients in formulation should be within the range of release controlling excipients in the established correlation.</p>	Single-dose bioequivalence study <sup>h</sup>
Filing	AR includes all documentation and LT stability data	Prior approval supplement; all information including accelerated stability data. Annual report to include long-term data.	<p><i>Prior approval supplement</i> all documentation and accelerated stability data</p> <p><i>Annual report</i>—long-term stability data</p>

Site changes<sup>i</sup>

Example

Site changes within a single facility where same equipment, SOPs, environmental conditions and controls, and personnel common to both manufacturing sites are used; no changes are made to manufacturing batch records, except administration info and location of facility. Common is defined as employees already working on the campus who have suitable experience in the manufacturing process.

Site changes within a contiguous campus or between facilities on adjacent city blocks, where same equipment, SOPs, environmental conditions and controls, and personnel common to batch manufacturing sites are used and where no changes are made to the manufacturing batch records except for administrative information and location of the facility.

Consist of change in manufacturing sites to different campus<sup>j</sup>  
To qualify: Same equipment, SOPs, and environmental conditions and controls should be used in the manufacturing process at the new site, and no changes may be made to the manufacturing batch records except for administrative info, location, and language translation, where needed.

Test and chemistry documents

None beyond application/compendial release requirements.

Location of new site and updated batch records. None beyond application/compendial release requirements.

One batch with accelerated stability reported in CBE. LT stability of first production batch in AR.

Location of new site and updated executed batch records.

Stability

*Sig. body of info available<sup>k</sup>*

One batch 3-mo. acc in suppl.  
First three production batches on stability in AR

*Sig. body of info not available<sup>k</sup>*

Three batches with 3 mo. acc in suppl.  
First three production batches on LT stability in AR

*(continued)*

**Table 4** *Continued*

	Level 1	Level 2	Level 3
Dissolution documents	None beyond application/compendial release requirements	<p><i>Extended release product:</i> Application/compendial release requirements plus multipoint dissolution profile in three other media (e.g., water, 0.1N HCl, and USP buffer media at pH 4.5 and 6.8).</p> <p><i>Delayed release product:</i> In application/compendial release requirements plus dissolution tests in 0.1N HCl for 2 hr (acid stage) followed by testing in USP buffer media (pH 4.5–7.5) under application/compendia test conditions and two additional agitation speeds. Application/compendial method may be either apparatus 1 or apparatus 2.<sup>1</sup> Adequate sampling should be performed (15, 30, 45, 60, and 120 min until either 80% of drug is released or asymptote is reached). Testing should be performed on changed product and biobatch or marketed product.</p> <p><i>In vitro/in vivo correlation established:</i> Only application/compendial dissolution testing is necessary.</p>	<p><i>Extended release product:</i> Application/compendial release requirements plus multipoint dissolution profile in application/compendial medium for the changed drug product and the biobatch or marketed batch (unchanged drug product). Adequate sampling should be performed (1, 2, and 4 hr and every 2 hr thereafter until either 80% of drug is released or asymptote is reached).</p> <p><i>Delayed release product:</i> Application/compendial release requirements plus multipoint dissolution profile should be obtained during the buffer stage of testing using the application/compendial medium for the changed drug and the biobatch or marketed product. Adequate sampling should be performed (15, 30, 45, 60, and 120 min until either 80% of the drug is released or asymptote is reached).</p>



In vivo bioequivalence	None	None	Single-dose bioequivalence study <sup>m</sup>
Filing	Annual report	CBE suppl. AR LT stability data	Prior approval supplement AR LT stability
Changes in batch size <sup>n</sup> (no level 3 changes defined)			
Example	Change in batch size up to and including a factor of 10× the size of the pilot/biobatch where Equipment used to produce the test batch(es) is of the same design and operating principles. The batch(es) is (are) manufactured in full compliance with CGMPs. The same SOPs and controls as well as the same formulation and manufacturing procedures are used on the test batch(es) and on the full-scale production batch(es).	Change in batch size, beyond 10× size of the pilot/biobatch where Equipment used to produce test batches is of the same design and operating principles The batch(es) is (are) manufactured in full compliance with CGMPs The same SOPs and controls as well as the same Rx and manufacturing procedures are used on the test batch(es) and on the full-scale production batch(es).	
Test and chemistry documents	Application/compendial release requirements Notification of change and submission of updated batch records in AR First production batch LT stability in AR	Application/compendial release requirements Notification of change and submission of updated batch records One batch with 3 mo. acc. in CBE. First production batch LT stability in AR	

(continued)

**Table 4** *Continued*

	Level 1	Level 2	Level 3
Dissolution documents	None beyond application/compendial release requirements	<p><i>Extended release product:</i> Application/compendial release requirements plus multipoint dissolution profile in three other media (e.g., water, 0.1N HCl, and USP buffer media at pH 4.5 and 6.8)</p> <p><i>Delayed release product:</i> In application/compendial release requirements plus dissolution tests in 0.1N HCl for 2 hr (acid stage) followed by testing in USP buffer media (pH 4.5–7.5) under application/compendia test conditions and two additional agitation speeds. Application/compendial method may be either apparatus 1 or apparatus 2.<sup>o</sup> Adequate sampling should be performed (15, 30, 45, 60, and 120 min until either 80% of drug is released or asymptote is reached). Testing should be performed on changed product and biobatch or marketed product.</p> <p><i>In vitro/in vivo correlation established:</i> Only application/compendial dissolution testing is necessary.</p>	

In vivo bioequivalence	None	None
Filing	AR, including all information plus LT stability data.	CBE supplement; all information including accelerated stability data AR LT stability data
Manufacturing changes <sup>p</sup> equipment (no level 3 changes defined)		
Example	Change from nonauto/nonmech. to auto or mech. equipment to move ingredients Change to alternative equipment of same design and operating principles <sup>q</sup> of the same or different capacity <sup>r</sup>	Change in equipment to a different design and different operating principles
Test and chemistry documents	Application/compendial release requirements Notification of change and submission of updated batch records Stability first production batch LT; data reported in AR	Application/compendial release requirements Notification of change and submission of updated batch records Stability test <i>Significant body of info</i> <sup>s</sup> : One batch 3 mo. acc data in suppl; first production batch LT stability in AR <i>Significant body of info N/A</i> <sup>t</sup> : Three batches acc in suppl; first 3 production batches LT in AR

**Table 4** *Continued*

	Level 1	Level 2	Level 3
Dissolution documents	None beyond application/compendial release requirements	<p><i>Extended release product:</i> Application/compendial release requirements plus multipoint dissolution profile in three other media (e.g., water, 0.1N HCl, and USP buffer media at pH 4.5 and 6.8)</p> <p><i>Delayed release product:</i> In application/compendial release requirements plus dissolution tests in 0.1N HCl for 2 hr (acid stage) followed by testing in USP buffer media (pH 4.5–7.5) under application/compendia test conditions and two additional agitation speeds. Application/compendial method may be either apparatus 1 or apparatus 2.<sup>1</sup> Adequate sampling should be performed (15, 30, 45, 60, and 120 min until either 80% of drug is released or asymptote is reached). Testing should be performed on changed product and biobatch or marketed product.</p> <p><i>In vitro/in vivo correlation established:</i> Only application/compendial dissolution testing is necessary.</p>	

In vivo bioequivalence	None	None	
Filing	AR LT stability data	PA suppl with justification for change—all information including accelerated stability data LT stability in AR	
Manufacturing process changes			
Example	Includes such process changes as mixing times and operating speeds within approved application ranges	Includes such process changes as mixing times and operating speeds outside approved application ranges	Includes change in the type of process used in the manufacture of the drug product, such as a change from wet granulation to direct compression of dry powder
Test and chemistry documentation	None beyond application/compendial release requirements Notification of change and submission of updated executed batch records	Application/compendial release requirements Notification of change and submission of updated batch records One batch 3 mo. accelerated stability in CBE. First production batch LT. Stability in AR.	Application/compendial release requirements Notification of change and submission of updated batch records <i>Stability:</i> Three batches accelerated data in suppl.; first three production batches LT stability in AR
Dissolution documents	None beyond application/compendial release requirements	<i>Extended release product:</i> Application/compendial release requirements plus multipoint dissolution profile in three other media (e.g., water, 0.1N HCl, and USP buffer media at pH 4.5 and 6.8) <i>Delayed release product:</i> In application/compendial release requirements plus dissolution tests in 0.1N HCl for 2 hr (acid stage)	<i>Extended release product:</i> Application/compendial release requirements plus multipoint dissolution profile in application/compendial medium for the changed drug product and the biobatch or marketed batch (unchanged drug product). Adequate sampling should be performed (1, 2, and 4 hr and every 2 hr thereafter until

(continued)

**Table 4** *Continued*

Level 1		Level 2	Level 3
		<p>followed by testing in USP buffer media (pH 4.5–7.5) under application/compendial test conditions and two additional agitation speeds. Application/compendial method may be either apparatus 1 or apparatus 2.<sup>u</sup> Adequate sampling should be performed (15, 30, 45, 60, and 120 min until either 80% of drug is released or asymptote is reached). Testing should be performed on changed product and biobatch or marketed product.</p> <p><i>In vitro/in vivo correlation established:</i> Only application/compendial dissolution testing is necessary</p>	<p>either 80% of drug is released or asymptote is reached).</p> <p><i>Delayed release product:</i> Application/compendial release requirements plus multipoint dissolution profile should be obtained during the buffer stage of testing using the application/compendial medium for the changed drug and the biobatch or marketed product. Adequate sampling should be performed (15, 30, 45, 60, and 120 min until either 80% of the drug is released or asymptote is reached).</p>
In vivo bioequivalence	None	None	In vivo bioeq required <sup>v</sup>
Filing	AR	CBE supplement AR-LT stability	PA supplement with justification AR-LT stability

<sup>a</sup> For modified-release solid oral dosage forms, consideration should be given as to whether or not the excipient is critical to drug release.

<sup>b</sup> Based on assumption that the drug substance in the drug product is formulated to 100% of label/potency. The total additive effect of all excipient changes should not be more than 5%. Allowable changes in the composition should be based on the approved target composition and not on previous level 1 changes in the composition.

- <sup>c</sup> Based on assumption that the drug substance in the drug product is formulated to 100% of label/potency. Total additive effect of all changes NGT 10%. Allowable changes in composition should be based on the approved target composition and not on the composition based on previous level 1 or level 2 changes.
- <sup>d</sup> Significant body of information on the stability of the drug product is likely to exist after 5 years of commercial experience for NMEs or 3 years of commercial experience for new dosage forms.
- <sup>e</sup> Using USP <711> apparatus 1 at 50, 100, and 150 rpm or apparatus 2 at 50, 75, and 100 rpm.
- <sup>f</sup> The bioequivalence study may be waived when an acceptable in vivo/in vitro correlation has been verified.
- <sup>g</sup> Based on assumption that the drug substance in the drug product is formulated to 100% of label/potency. Total additive effect of all changes NGT 10%. Allowable changes in composition should be based on the approved target composition and not on the composition based on previous level 1 or level 2 changes.
- <sup>h</sup> The bioequivalence study may be waived when an acceptable in vivo/in vitro correlation has been verified. Changes in release controlling excipients should be within the range of release controlling excipients of the established correlation.
- <sup>i</sup> Consist of changes in location of the site of manufacture for both company-owned and contract manufacturing facilities and do not include scale-up changes, changes in manufacturing (including process and/or equipment), or changes in components or composition. New manufacturing location should have satisfactory CGMPs inspection.
- <sup>j</sup> Different campus—one that is not on the same original contiguous site or where the facilities are not on adjacent city blocks.
- <sup>k</sup> Significant body of information on the stability of the drug product is likely to exist after 5 years of commercial experience for NMEs or 3 years of commercial experience for new dosage form.
- <sup>l</sup> Using USP <711> apparatus 1 at 50, 100, and 150 rpm or apparatus 2 at 50, 75, and 100 rpm.
- <sup>m</sup> The bioequivalence study may be waived when an acceptable in vivo/in vitro correlation has been verified.
- <sup>n</sup> Postapproval changes in the size of a batch from the pivotal/pilot scale biobatch materials to larger or smaller production batches call for submission of additional information in the application. Scale down below 100,000 dosage units is not covered by this guideline. All scale-up changes should be properly validated and where needed, inspected by appropriate agency personnel.
- <sup>o</sup> Using USP <711> apparatus 1 at 50, 100, and 150 rpm or apparatus 2 at 50, 75, and 100 rpm.
- <sup>p</sup> Changes may affect both equipment used in the manufacturing process and the process itself.
- <sup>q</sup> Agreeing in kind, amount; unchanged in character or condition. See SUPAC IR/MR Immediate Release and Modified Release Solid Oral Dosage Forms Manufacturing Equipment Addendum (January 1999).
- <sup>r</sup> Rules or concepts governing the operation of the system.
- <sup>s</sup> Significant body of information on the stability of the drug product is likely to exist after 5 years of commercial experience for NMEs or 3 years of commercial experience for new dosage form.
- <sup>t</sup> Using USP <711> apparatus 1 at 50, 100, and 150 rpm or apparatus 2 at 50, 75, and 100 rpm.
- <sup>u</sup> Using USP <711> apparatus 1 at 50, 100, and 150 rpm or apparatus 2 at 50, 75, and 100 rpm.
- <sup>v</sup> May be waived if a suitable in vivo/in vitro correlation has been verified.

Forms.” In the SUPAC guidance, it is noted that the order of addition of the solutes to the solvent is usually not important. The critical point of a semisolid manufacturing process is the initial separation of a one-phase system into two phases and the point at which the active ingredient is added. Solubility of each added ingredient is important for determining whether or not a mixture is visually a single homogeneous phase. Consequently, supporting data such as optical microscopy should be available for review, especially for solutes added to the formulation at a concentration near or in excess to their solubility at any temperature to which the product may be exposed [10].

This guidance covers the following changes: components and composition, manufacturing equipment and process, batch size, and manufacturing site. These changes are generally broken down into three different levels of changes, with a definition of the level, required test documentation (chemistry, in vitro release, and in vivo release documentation), and filing requirements for each level listed. The components and composition section adds a section containing three levels of changes made to the preservative (no in vitro release and in vivo release documentation required for preservative changes).

As first printed in SUPAC-IR and later in SUPAC-MR, level 1 changes are unlikely to have any detectable impact on formulation quality or performance, and are consequently annual reportable changes. Level 2 changes could have a significant impact on formulation quality and performance, and are thus CBE supplements. Level 3 changes are likely to have a significant impact on formulation quality and performance and are either CBE supplements or prior approval supplements. Details regarding this guidance may be located in [Table 5](#).

### C. Proposed SUPAC Documents

To date there are only six published SUPAC [11] documents. All of these documents are listed in items 1 through 5 above except the *SUPAC IR/MR Immediate Release and Modified Release Solid Oral Dosage Forms Manufacturing Equipment Addendum*, issued in January of 1999. This guidance document is referenced in both the SUPAC-IR and SUPAC-MR tables. In addition to these six documents, there are two *draft* documents released by the FDA: *BACPAC I: Intermediates in Drug Substance Synthesis/Bulk Actives Post Approval Changes: Chemistry, Manufacturing and Controls Documentation*, which gives guidance for PACs in drug substances up to but not including the final intermediate (issued November 1998), and *SUPAC SS: Nonsterile Semisolid Dosage Forms Manufacturing Equipment Addendum* issued in December of 1998. Since these documents are draft documents, they will not be discussed in depth in this chapter. Proposed (but not issued in draft form) documents include BACPAC II, which is anticipated to give guidance on PACs in bulk actives from the final



**Table 5** SUPAC-SS (Semi-Solid Dosage Forms)

	Level 1	Level 2	Level 3
Components and composition—excipients			
Example	Any change in excipient up to 5% in the total formulation <sup>a</sup> Changes in the supplier of a structure forming excipient that is primarily a single chemical entity (purity $\geq 95\%$ ) Change in supplier or technical grade of any excipient other than a structure forming excipient	Changes of $>5\%$ and $\leq 10\%$ of an individual excipient in the total formulation <sup>b</sup> Change in supplier of structure forming excipient not covered in level 1 Change in technical grade of a structure forming excipient Change particle size distribution of the drug substance if the drug is in suspension.	Any quality/quantity changes to an excipient beyond ranges in level 2 Changes in crystalline form of the drug substance if the drug is in suspension.
Test and chemistry documentation	Application/compendial release requirements and stability testing Stability first production batch long-term data in annual report	Application/compendial release requirements and executed batch records Stability testing—one batch, 3 mo.; accelerated stability data in CBE and first production batch on long-term stability; data reported in annual report	Application/compendial release requirements and executed batch records <i>Significant body of info<sup>c</sup> available</i> One batch 3 mo. in supplement First three production batches long-term stability in AR <i>Significant body of info<sup>a</sup> not available</i> Three batches with 3 mo. accelerated stability in supplement First three production batches long-term stability in AR

*(continued)*

**Table 5** *Continued*

	Level 1	Level 2	Level 3
In vitro release documentation	None	In vitro release rate compared to recent lot of comparable age pre-change product. Median in vitro release rates <sup>d</sup> of the two formulations should be within acceptable limits. <sup>c</sup>	In vitro release rate of new/modified formulation established as point of reference. In vitro release documentation not required, but this information should be developed for use in subsequent changes.
In vivo bioequivalence	None	None	Full bioequivalence study on highest strength, with in vitro release/other approach on lower strength(s).
Filing	AR includes all documents and stability data	CBE supplement all information, including accelerated stability data; annual report long-term stability data	Prior approval supplement documents and accelerated stability data; annual report-long-term stability data
Components and composition—preservative			
Example	10% or less change in approved amount of preservative	>10% and ≤20% change in approved amount of preservative	>20% change in approved amount of preservative Use of new preservative
Test documentation chemistry documentation	Application/compendial product release requirements Preservative effectiveness test carried out at lowest preservative level	Application/compendial product release requirements Preservative effectiveness test carried out at lowest preservative level	Application/compendial product release requirements Preservative effectiveness test carried out at lowest preservative level Analytical method for identification and assay for new preservative

			Validation studies to show that the new preservative does not interfere with application/compendial tests
			Executed batch records
			Stability: One-batch 3 mo. accelerated stability data in PA supplement; first production batch long-term stability in annual report
Filing	Annual report	CBE supplement	Prior approval supplement—all information including accelerated stability data; annual report—long-term stability.
Manufacturing changes <sup>f</sup> —equipment			
Example	Change from nonauto/nonmech. to auto or mech. equip to transfer ingredients	Change in equipment to a different design and different operating conditions	None defined
	Change to alternative equipment of same design and operating principles <sup>g</sup>	Change in type of mixing equipment, such as high shear to low shear	
Test documentation chemistry documentation	Application/compendial release requirements Notification of change and submission of updated batch records.	Application/compendial release requirements Notification of change and submission of updated batch records.	

(continued)

**Table 5** *Continued*

	Level 1	Level 2	Level 3
	Stability first production batch long-term, data reported in annual report	Stability Test <i>Significant body of info<sup>h</sup> available:</i> one batch 3-mo. acc report in CBE; first production batch long-term stability in annual report. <i>Significant body of info not available:<sup>h</sup></i> three batches acc in CBE; first three production batches long-term data in annual report	
In vitro release documentation	None	In vitro release rate compared to recent lot of comparable age pre-change product. Median in vitro release rates <sup>i</sup> of the two formulations should be within acceptable limits. <sup>j</sup> In vitro release rates. <sup>k</sup>	
In vivo bioequivalence	None	None	
Filing	Annual report, including information and long-term stability data	CBE supplement—all information, including accelerated stability data Long-term stability data in annual report	

Manufacturing changes<sup>1</sup>—process

Example	Includes such process changes as mixing rates, times, operating speeds, and holding times within application ranges Order of addition of components (except actives) to either oil or water phases	Includes such process changes as mixing rates, times cooling rate, operating speeds, and holding times outside application ranges Any change in process of combining the phrases	None defined
Test documentation chemistry documentation	None beyond application/compendial release requirements	Application/compendial release requirements Notification of change and submission of updated batch records Stability Test <i>Significant body of info<sup>m</sup> available:</i> One batch 3-mo. acc report in CBE; first production batch long-term stability data in annual report <i>Significant body of info<sup>m</sup> not available:</i> Three batches accelerated data in CBE First three production batches long-term data in annual report	
In vitro release documentation	None	In vitro release rate compared to recent lot of comparable age pre-change product. Median in vitro release rates <sup>n</sup> of the two formulations should be within acceptable limits <sup>o</sup> . in vitro release rates	

(continued)

**Table 5** *Continued*

	Level 1	Level 2	Level 3
In vivo bioequivalence	None	None	
Filing	Annual report	CBE supplement—all information, including accelerated stability data Long-term stability data in annual report	
Changes in batch size <sup>p</sup>			
Example	Change in batch size, up to and including a factor of 10× the size of the pilot/biobatch where Equipment used to produce the test batch(es) is of the same design and operating principles. The batch(es) is (are) manufactured in full compliance with CGMPs. The same SOPs and controls as well as the same formulation and manufacturing procedures are used on the test batch(es) and on the full-scale production batch(es).	Change in batch size, beyond 10× size of the pilot/biobatch where Equipment used to produce test batches is of the same design and operating principles. The batch(es) is (are) manufactured in full compliance with CGMPs. The same SOPs and controls as well as the same Rx and manufacturing procedures are used on the test batch(es) and on the full-scale production batch(es).	None defined

Test and chemistry documentation	Application/compendial release requirements Notification of change and submission of updated batch records in AR First production batch long-term stability in AR	Application/compendial release requirements Notification of change and submission of updated batch records One batch with 3 mo. accelerated stability data in CBE supplement First production batch long-term stability	
In vitro release documentation	None	In vitro release rate compared to recent lot of comparable age pre-change scale of product. Median in vitro release rates <sup>q</sup> of the two formulations should be within acceptable limits. <sup>r</sup> In vitro release rates	
In vivo bioequivalence	None	None	
Filing	Annual report all information, including long-term stability	CBE supplement, including all info plus accelerated stability data Annual report long-term stability data	
Site changes <sup>s</sup> Example	Site changes within a single facility where same equipment, SOPs, environmental conditions and controls, and personnel common to both manufacturing sites are used; no changes are made to manufacturing batch records, except administrative info and location of the facility. Common is defined as employees already working on the campus who have suitable experience in the manufacturing process.	Site changes within a contiguous campus, or between facilities on adjacent city blocks, where same equipment, SOPs, environmental conditions and controls, and personnel common to batch manufacturing sites are used and where no changes are made to the manufacturing batch records except for administrative information and location of the facility.	Change in manufacturing sites to different campus. <sup>t</sup> To qualify: Same equipment, SOPs, and environmental conditions and controls should be used in the manufacturing process at the new site, and no changes may be made to the manufacturing batch records except for administrative info, location, and language translation, where needed. Change to new contract manufacturer.

(continued)

**Table 5** *Continued*

	Level 1	Level 2	Level 3
Test and chemistry documentation	None beyond application/compensial release requirements	Location of new site and updated executive batch records. None beyond application/compensial release requirements First production batch on long-term stability; data reported in AR	Location of new site and updated batch records. Application/compensial release requirements Stability: <i>Sig. body of info available<sup>u</sup></i> : One batch 3-mo. acc. cond. in suppl. One batch on LT stability in AR <i>Sig. body of info<sup>u</sup> not available</i> : Up to three batches with 3-mo. acc. cond. in Suppl. Up to three batches on LT stability in AR
In vitro release documentation	None	None	In vitro release rate compared to recent lot of comparable age pre-change scale of product. Median in vitro release rates <sup>v</sup> of the two formulations should be within acceptable limits. <sup>w</sup> in vitro release rates
In vivo bioequivalence	None	None	None
Filing	Annual report	CBE supplement Annual report: long-term stability data	CBE supplement—all info, including accelerated stability data Annual report: long-term stability data

<sup>a</sup>The total additive effect of all excipient changes should not be more than 5%. Allowable changes in the composition should be based on the approved target composition and not on previous level 1 changes in the composition.



- <sup>b</sup> Total additive effect of all changes NGT 10%. Allowable changes in composition should be based on the approved target composition and not on the composition based on previous level 1 or level 2 changes. Changes in diluent (q.s. excipient) due to component and composition changes in excipients are acceptable and are excluded from the 10% change limit.
- <sup>c</sup> Significant body of information on the stability of the drug product is likely to exist after 5 years of commercial experience for NMEs or 3 years of commercial experience for new dosage forms.
- <sup>d</sup> Estimated by estimated slope from each slope. See guidance, Sect. VII for details.
- <sup>e</sup> See guidance Sect. VII for testing procedure.
- <sup>f</sup> Changes may affect both equipment used in the manufacturing process and the process itself.
- <sup>g</sup> Agreeing in kind, amount; unchanged in character or condition.
- <sup>h</sup> Significant body of information on the stability of the drug product is likely to exist after 5 years of commercial experience for NMEs or 3 years of commercial experience for new dosage form.
- <sup>i</sup> Estimated by estimated slope from each slope. See guidance, Sect. VII, for details.
- <sup>j</sup> See guidance Sect. VII for testing procedure.
- <sup>k</sup> Estimated by estimated slope from each slope. See guidance, Sect. VII, for details.
- <sup>l</sup> Changes may affect both equipment used in manufacturing process and the process itself.
- <sup>m</sup> Significant body of information on the stability of the drug product is likely to exist after 5 years of commercial experience for NMEs or 3 years of commercial experience for new dosage form.
- <sup>n</sup> Estimated by estimated slope from each slope. See guidance, Sect. VII for details.
- <sup>o</sup> See guidance Sect. VII for testing procedure.
- <sup>p</sup> Postapproval changes in the size of a batch from the pivotal/pilot scale biobatch materials to larger or smaller production batches call for submission of additional information in the application. Scale down below 100,000 dosage units is not covered by this guideline. All scale-up changes should be properly validated and where needed, inspected by appropriate agency personnel.
- <sup>q</sup> Estimated by estimated slope from each slope. See guidance, Sect. VII for details.
- <sup>r</sup> See guidance, Sect. VII for testing procedure.
- <sup>s</sup> Consist of changes in location of the site of manufacture for both company-owned and contract manufacturing facilities and do not include scale-up changes, changes in manufacturing (including process and/or equipment) or changes in components or composition. New manufacturing location should have a satisfactory CGMP inspection.
- <sup>t</sup> Different campus—one that is not on the same original contiguous site or where the facilities are not on adjacent city blocks.
- <sup>u</sup> Significant body of information on the stability of the drug product is likely to exist after 5 years of commercial experience for NMEs or 3 years of commercial experience for new dosage form.
- <sup>v</sup> Estimated by estimated slope from each slope. See guidance, Sect. VII for details.
- <sup>w</sup> See guidance, Sect. VII for testing procedure.

intermediate to the final dosage form, and PAC-SAS, covering PACs for sterile aqueous solutions.

#### **IV. CHANGE CONTROL AND SUPAC**

Although the finalization of the SUPAC guidance documents has been very helpful in defining the documentation necessary for a submission to the FDA, there may still be data requirements that exceed those listed in the guidances that are necessary to satisfy quality concerns. It should be further noted that GMP requirements, located in 21 CFR parts 210 and 211, also need to be met; SUPAC does not replace GMPs. Requirements listed in the SUPAC guidances are not all-inclusive, as other testing and data requirements may need to be completed to satisfy all safety, quality, and purity concerns raised by all interested and appropriate functional groups and the quality unit.

#### **V. CONCLUSION**

There are many nuances regarding change control that must be investigated thoroughly before the change is made. Changes proposed far in advance of their need are those that are implemented most seamlessly. These changes are thoroughly discussed, documented, tested, and if necessary filed and approved by appropriate regulatory agencies prior to being implemented. Developing, implementing, and following a written corporate change control procedure is the only viable method for ensuring the changes made in your company that may impact your products will have no deleterious impact on any of your products. According to existing CGMPs, the quality unit should be the owner of this change control process, and should review and approve any changes made, along with other functional groups as appropriate. To ensure there is no impact to regulatory filings, or where there is impact to ensure it is appropriately documented, the regulatory affairs group in your company should be contacted. Where a filing is necessary, the appropriate SUPAC guidance should be consulted to ensure the proper filing is made, along with the appropriate documentation.

Following these procedures, changes made in your company should be seamless, without any interruption in the quality and purity of your products.

#### **VI. CLOSING SUMMARY**

In this chapter, we affirmed that in the pharmaceutical industry change control does not mean the elimination of any change; it means the systematic control of changes to ensure the changes made do not have any adverse impact on the

safety, quality, purity, or potency of the pharmaceutical product. Recognizing the need for changes, the FDA finalized several guidelines that delineate the data and filing requirements for many PACs. These guidelines, known as scale-up and postapproval changes (SUPAC) guidances list many of the most common changes made in oral solids (both immediate release and modified release forms), semisolids, and analytical testing, packaging, and manufacturing locations. In addition, the FDA has planned to issue several additional SUPAC guidelines to cover bulk active pharmaceutical ingredients (APIs) and sterile products.

## REFERENCES

1. 21CFR 210 and 211: Current Good Manufacturing Practice in Manufacturing, Processing, Packaging, or Holding of Drugs; General. Washington, DC: U.S. Government Printing Office, (1999).
2. Stephon, D. M. Considerations in effectively managing change control issues. *J cGMP Comp* 2 (4), (July 1998).
3. *Fed Reg* 61 (87) 20113 (May 3, 1996).
4. National Transportation and Safety Board. report number NTSB-AAR-79-17 (Dec. 21, 1979).
5. Skelly, J. P., Van Buskirk, G. A., Savello, D. R., Amidon, G. L., Arbit, H. M., Dighe, S., Fawzi, M. B., Gonzalez, M. A., Malick, A. W., Malinowski, H., Nedich, R., Peck, G. E., Pearce, D. M., Shah, V., Shangraw, R. F., Schwartz, J. B., True-love, J. Scaleup of immediate release oral solid dosage forms. *Pharm Res* 10 (3), (1993).
6. *Fed Reg* 60 (230) 61637–61643 (Nov. 30, 1995).
7. CMCCC, CDER, FDA. Guidance for Industry—Changes to an Approved NDA or ANDA. Drug Information Branch, CDER, FDA (November 1999).
8. CDER, FDA. SUPAC IR/MR Equipment Addendum. U.S. Department of Health and Human Services (Jan. 1999).
9. CDER FDA. Guidance for Industry, PAC-ATLS: Postapproval Changes—Analytical Testing Laboratory Sites. U.S. Department of Health and Human Services (April 1998).
10. CDER, FDA. Guidance for Industry, Nonsterile Semisolid Dosage Forms. U.S. Department of Health and Human Services (May 1997).
11. IR, MR, SS, Questions and Answers Letter on Stand-Alone Packaging Site Changes, PAC-ATLS, and the Equipment Addendum.

# 21

## Process Validation and Quality Assurance

**Carl B. Rifino**

*AstraZeneca Pharmaceuticals LP, Newark, Delaware, U.S.A.*

In the first edition of this book, Loftus [1] focused on the factors that justify the need for the documentation of process validation (PV). These factors included needs associated with current good manufacturing practice (CGMP), the concept of efficient manufacturing processes, the team approach to development and plant introductions, and the planning of activities involving the validation effort itself. The second edition [2] expanded this focus by looking at the ways in which process validation should be viewed as part of the continuum of technology transfer activity. This would include looking at the factors that will constitute the validation effort, carrying out the testing that will demonstrate the fact that the process is reproducible, and making PV an integral part of a total quality management (TQM) effort.

It is interesting to note how PV and quality assurance (QA) have expanded to include not only technology transfer but also some of the development activity; namely, PV associated with clinical supplies production. Another factor that has influenced the need to validate the manufacturing process is the involvement of the contractor, whose site has become the primary or alternate location for the sponsor to manufacture the clinical or commercial product. With this expansion it was inevitable that organizations would formalize the master validation plan as a building block of TQM. Furthermore, it is appropriate to include the validation plan for each clinical production process in the master validation plan.

This evolution should probably be credited to the efforts of both industry and government. The Food and Drug Administration's (FDA's) *Guideline on the Preparation of Investigational New Drug Products* stated that clinical prod-

ucts must be manufactured using a validated process [3]. More will be discussed on this subject later in the chapter. Industry has approached the challenge by instituting QA units in their pharmaceutical research departments, whose remit has covered either the traditional QA activity or the compliance issues. In some cases, however, the scope of the QA unit has included both QA and compliance responsibilities.

Juran [4] defined QA as the activity of providing to all concerned the evidence needed to establish confidence that the quality function is being performed adequately. The definition of PV is that it is the total activity, showing that the process will do what it is purported to do. The relationship of QA and PV goes well beyond the responsibility of any QA function; nevertheless, it is fair to say that PV is a QA tool because it establishes a quality standard for a specific process.

It should be recognized that most pharmaceutical companies develop quality statements as part of their business rationale. This declaration often includes much, if not all, of the following precept [5]: It is the policy of the company to provide products and services of a quality that meets the initial and continuing needs as well as the expectations of the customer in relation to the price paid and to the nature of competitive offerings, and in so doing, to be the leader in product quality reputation.

Quality assurance in pharmaceutical companies embodies the effort to ensure that products have the strength, purity, safety, and efficacy represented in the company's new drug application (NDA). For new drug products, QA has also become the effort that is needed to satisfy the consumer or to achieve an established standard of excellence. The total effort requires that sound working relationships be developed among the QA, development, and production departments. Other groups such as engineering may be included in this effort.

In recent years, quality awareness has been stressed as companies seek world-class status for their operations. Such QA programs that have been adopted are outside the scope of this chapter, but they include some of the following factors: certifying suppliers, setting standards for customer satisfaction both within and outside the organization, and incorporating statistical process control (SPC) in manufacturing operations. In addition, the need for quality standards for personnel involved in production, development, and QA work is well recognized. This discussion will be limited to how PV might be used to develop quality standards.

Although QA is usually designated as a departmental function, it must also be an integral part of an organization's activities. When PV becomes a general objective of the technical and operational groups within an organization, it becomes the driving force for quality standards in development work, engineering activities, QA, and production. Process validation is valuable to an organization when it consists of good and pragmatic science. To appreciate this

concept, one must go beyond Juran's definition of QA; thus instead of QA just being an activity that provides evidence to establish confidence that the quality function is being performed adequately, it must become a measure of the technical group's ability to add value to its work for the sake of its company and its company's customers.

Nash [6] stated that QA was originally "organized as a logical response to the need to assure that cGMPs were being complied with." He concluded that "it is not surprising that process validation became the vehicle through which Quality Assurance now carries out its commitment to cGMPs" [7]. In addition, PV has become the vehicle through which QA shares this commitment with the pharmaceutical development, production, and engineering departments.

## **I. QUALITY ASSURANCE AND THE ORGANIZATION**

The QA that exists within an organization rests not only on the management of the quality function but also on the activities that occur on a daily basis in the company's technical and operational functions. These groups are responsible for the training of the personnel to achieve a company culture based on quality. They develop and carry out the procedures that govern the product composition, the manufacturing process, the test criteria, or the operating system, which ensures that the quality function is performed adequately.

Jeater et al. [8] outlined the many facets of validation work within a pharmaceutical company. No matter which subject of validation work is undergoing testing, the method of testing (challenge) provides a measure of QA to a company's operations. Furthermore, there is a clear implication that if any tested function is found wanting, corrective action will be taken to assure compliance in the affected area. For example, when personnel are tested for their qualifications and found wanting, training or some other management response is undertaken. Similarly, when the design of a process or facility is inadequate, process improvement, replacement, or preventive maintenance activity usually follows. The other subject areas, such as raw materials and components, procedures, packaging and manufacturing functions, and equipment, would likewise receive appropriate attention.

### **A. Pharmaceutical Development**

This function is responsible for the design of the finished dosage form as well as the qualification of the manufacturing process. Its effort will also become the basis of the documentation required for the preapproval clearance of NDAs, which will be carried out by the FDA. The level of quality associated with its

scientific performance will thus greatly affect the product's commercial availability.

Rudolph [9] presented a checklist that might be used to develop an in-depth program for the validation of all solid dosage forms. This type of checklist enables the scientist to determine what data must be collected and which data demonstrate that the process is under control. Table 1 lists a portion of the checklist.

The basis of these checklist points is as follows: to develop knowledge about the formula composition, to develop knowledge about the process and equipment used (Table 2), and to understand the mutual influences of the formula composition and process (or equipment) on each other. They focus on

**Table 1** Checklist Leading to the Optimization/Validation of a Solid Dosage Form

---

- I. Tablet composition: provide the reason for the presence of each ingredient in the formula.
    - A. What are the "normal" properties of each ingredient?
    - B. Do these properties change in the formula under study?
    - C. What are the characteristics of the initial powder blends, the wet/dry granulations, and the final blends?
    - D. Density: "loose" vs. "tap" of blend.
    - E. Particle size distribution of blend.
    - F. Surface area of the final blend.
    - G. Flow properties, such as contact angle.
    - H. Moisture content, if applicable.
  - II. Process evaluation and selection: Determine the processing steps needed for the initial scale-up.
    - A. Blending operations (as applicable). Determination of the optimal blending time based on:
      1. Does extensive blending cause demixing and segregation of components? This is important, especially if particle size/density of the powder/granulation vary widely.
      2. What tests are used to assess the uniformity of the final product? Content uniformity, weight variation testing?
    - B. Is the granulation adequately blended to achieve the desired distribution of the active ingredient in the mix?
    - C. Check for a possible interaction between the process and its effect on tablet core compression.
    - D. Check the characteristics of the blend: bulk density, particle size distribution, moisture (if applicable).
    - E. Does any ingredient affect the density of the final blend?
    - F. What is the blending performance at 30, 50, and 100% of working capacity?
-

**Table 2** Checklist Concerned with Blending Equipment for the Optimization and Validation of Solid Dosage Forms

---

1. What is the working capacity of the equipment?
  2. Is the efficiency of the equipment affected by the density of the material?
  3. What is the appropriate working load range to ensure good uniformity and homogeneity of the blend?
  4. What material-handling features does the equipment have?
  5. Is the equipment capable of wet granulating the powder?
  6. Can the equipment heat the powder blend, if it is needed as a granulator-dryer?
  7. May vacuum drying be used to assist in the drying?
- 

solid dosage forms, but these same activities may also be undertaken for other dosage forms. (See [Table 3](#).) These checklists are useful to both the formulator and the process technologist for a developmental strategy. They also form the basis for adding value to the work they perform. It is suggested that these checklists be modified to suit the scope of the development program, making them equally applicable for small or large projects. Furthermore, they are a planning activity, which would also be useful as the basis for the validation protocol.

The QA associated with the pharmaceutical development effort includes the following general functions:

1. To ensure that a valid formulation is designed
2. To qualify the process that will be scaled up to production-sized batches
3. To assist the design of the validation protocol program, which will become the object of the FDA's preapproval clearance
4. To manufacture the biobatches for the clinical program
5. To work with production and engineering to develop and carry out the qualification program for production equipment and facilities/process systems
6. To develop validated analytical methods to allow
  - a. The stability program to be carried out
  - b. The testing of raw materials and finished product
  - c. The development of release specifications for the raw materials and finished product
  - d. The testing of processed material at certain specified stages

In the last revision, PV was called [10] the QA of pharmaceutical technology. The point was made to emphasize the fact that PV involved the validation of the manufacturing process, not the product per se. The distinction was made because the product results from the way in which the process is carried out.



**Table 3** Checklist on Process Evaluation Leading to Optimization and Validation of a Liquid Sterile Dosage Form

---

1. Mixing tank
    - What kind of agitator system is needed to dissolve all the ingredients efficiently?
    - What composition must the tank's product contact points be (e.g., stainless 316L, glass)?
  2. Process services
    - Does the process require a jacketed tank to heat the product?
    - What source of heat is required (e.g., hot water, steam)?
    - Does the product require protection from oxygen?
    - What other protection does the product require during processing?
  3. Sterilizing conditions
    - Will the product require sterilization of the bulk liquid?
    - Is it possible to sterilize the product terminally or must the product be aseptically processed?
    - How long does it take to reach the sterilizing conditions? How long is the cool-down period? Must the batch size be controlled to achieve the needed sterilizing conditions?
  4. Container
    - What composition is the container?
    - Will the container affect or be affected by the product?
    - Does the stopper interact with the product during any part of the product's lifetime?
    - Will the properties of the stopper or container be affected by heat sterilization?
- 

Process validation verifies that the process will consistently produce the desired product each time it is run. It must be remembered that PV for the development process may not contain as much supporting data as is collected for the process when the product's NDA is being reviewed. The development group must still view the validation effort in a way that adds value to its work, however. The steps are as follows:

1. Define the process and determine which process steps are the critical ones. If the technologist has progressed adequately from the checklist stage to the stage at which the process is known and understood, these steps should be readily identified.

When the development function looks at the PV activity as a QA tool, it must view each process step very closely. The development plan must ensure that the ability and limitations of the process design are known. This can come about only if sound planning occurs at the beginning, which should include dissection of the process into discrete parts and the ability to evaluate them. This has been a very

complex task for solid dosage form processes, and herein lies the opportunity for using good pragmatic approaches [11] for the task. It must be understood, however, that perfection should not be the target of the validation effort. The scientist should thus evaluate only what can be measured with confidence and each process activity that can be controlled.

2. Define which process variable will be used as the monitoring device of each process step.

Let's look at the wet granulation step, for example. We will want to learn whether or not it affects the dissolution of the drug, the final blend performance, the drying and milling procedures, and the final tablet compression performance. If QA is to result from the development effort, answers must be had. The task cannot be left only to the process development scientist to solve, however. Thus, the pragmatic approach to the scientific effort would be that the answer be developed through the partnership of the physical pharmacist, the formulator, and the process development engineer (or scientist).

The formulator and the pharmaceutical scientist should determine how drug dissolution can be affected (i.e., Would it be affected by the formula composition or by the physical characteristics of the drug or granule?). The process engineer must also determine whether the granulation quality will be affected by the choice of equipment or whether it will affect the milling characteristics or tablet quality. After the preliminary work is satisfactorily completed, the scope of the process engineer's work may become clearer, thus if the physicochemical properties of the drug or the formulation are not a factor, the process step alone will become the focus of the scale-up work, which markedly reduces the number of process experiments required.

On the other hand, if the drug or formulation is a factor, it may become necessary to control tightly and measure each facet of the granulation step. This may result in a program that requires close monitoring of the way the granulating fluid is mixed into the batch, the blending of the dry powders prior to granulation, a specific volume of granulating fluid, and the instrumentation needed to control the process itself. If the technical plan includes this kind of evaluation, it will become pragmatic enough to allow either approach, therefore the technical plan must first determine whether or not the formula or process significantly affects the granulation's quality. If the process step is significant, the plan objective must be to fully understand the process step's capabilities and limitations.

3. Generate the data. During the development effort, the data generated while the process is being qualified will determine what the specifica-

tion limits will be for each test. The development/statistical team will choose the “three-sigma” rule of thumb or some other standard criterion to set the specification limits around the target. If there are specific cautions needed to ensure against a deviation in product performance, however, these cautionary limits may have to be customized accordingly.

For example, the drug’s content uniformity in the final tablet may yield a relative standard deviation greater than 6%, even though the uniformity of the powder blend is much tighter. It may become necessary to control not only the powder blend’s uniformity but also its particle size distribution, thus in order to meet the necessary criteria for the latter test, it may be necessary to control the blend process by setting tighter specification limits for the former test.

4. Statistically evaluate the data from the validation effort. Compare the data with the specification limits listed in the protocol. Conformance to these limits is essential, because this effort must also include the determination of whether failure signifies a missing link in the scientists’s understanding of the process. This exercise is especially important when the size of the validation batch is significantly larger than the largest development batch made to date.
5. The validation function reviews the results of all the validation batches using the protocol as a basis of comparison. In addition, the group will review the equipment qualification work and/or its calibration program. This total effort will help to ensure the quality of the finished product. This provides a formal turnover mechanism from process development to production, and the actual work forms a database for any future technical activity. It follows that it would also be useful as the basis for any future work that may be required on the process, including process improvement, change control, or troubleshooting. Furthermore, documentation of the effort enhances its scientific stature both within the company and, as needed, outside it (e.g., FDA inspections). The main benefit of the validation effort being realized within the organization, is that both the production unit and the quality control group have acceptable reference points to assist them in carrying out their responsibilities.

The example of the wet granulation step demonstrates that good planning of the development effort provides a solid basis for the best understanding of a process. It also demonstrates how the quest to achieve PV for a process will promote QA. Another major benefit of PV, however, is that it requires the personal commitment of the involved individuals to QA by setting validation objec-

tives for them. This extra step makes it necessary for them to accept the quality functions of the organization as their own and to bring good science to PV. Herein lies the opportunity to evaluate development personnel and the quality of their work, an idea suggested earlier [12].

Process validation affects a number of job activities that an R&D manager can control or utilize. It offers the manager a job enrichment opportunity for subordinates. By encouraging personnel to evaluate process design and process capability, the manager will seek good science from subordinates. In addition, the organizational goals to prepare for preapproval inspections by FDA personnel would be enhanced by this work. It provides a tool for the manager to evaluate the quality of work coming from each subordinate (e.g., planning work activity, program organization, data development, and overall job performance).

The ultimate benefit of PV to pharmaceutical development is that it is an approach to demonstrate a quality standard for a given process, whether the batching occurs during development or during the commercial stages of a product's life. This activity has become associated with CGMP, and FDA representatives have stated that batching activity, which yields a product intended for ingestion by humans, needs validation data [3]. In the cited guideline, FDA stated that "limited validation . . . should be derived . . . from product and process analogs." Although this recognizes that only limited data would be available in the early development stages, it leaves open the possibility that the database will be increased as additional batches are manufactured.

This approach would seem to be an example of concurrent PV [14], which fits well when the development function continues its effort to validate clinical manufacturing processes. It is also an opportunity to validate a process when it is used to produce different batch sizes with a given piece of equipment. It may even be possible to employ differently sized equipment (to make different batch sizes) as part of the validation effort. It remains to be determined whether this kind of approach ought to be extended to the commercial validation effort. Later in this chapter I will discuss the possibility, which should be attractive for the company that is totally involved in TQM.

## **B. Production**

This department needs PV for a number of reasons. First, the completed validation program serves as the formal transfer of the process to the production function. Through validation, it would be demonstrated that a controlled process was established. It doesn't guarantee that nothing will go wrong, but it will say what process was validated and it will require that any change must be examined beforehand. In this way, it will require that the organization formally evaluate whether or not a proposed change warrants a new development and/or validation

effort. This will also avoid the comment that the previous validated process is no longer validated.

Process validation is also useful for the production function, because the data generated may be used as a basis for SPC. Statistical process control is useful for collecting data, but there must be useful limits to control the process variables by allowing standard equipment adjustments to obtain quality product continuously. Validation data enable a company to develop a database to do just that. Furthermore, when normal adjustments no longer control the process variables, the validation data become the basis to judge whether there has been a statistical change in the process. The rational process to such a finding would be a demonstrated need for process improvement or a troubleshooting effort.

Quality assurance in production is the result of careful planning. In their discussion on quality in manufacturing, Ekvall and Juran [15] refer to setup dominance and machine dominance. The former approach seeks to create a highly reproducible process, which would include a means of self-control. The latter is concerned with the variability that is caused by the equipment's performance. Many older production processes appeared to rely on the machine-dominance strategy because they relied on in-process checks and adjustments as needed. Process validation, however, leans toward setup dominance because this activity seeks to document the fact that the variable process parameters are under control, which means that the in-process test results will be within their specification limits.

In a setup-dominant process, it is important that the development function understand where the setup must be centered (targeted). This information is most useful when instruments can effectively and accurately measure the property of the intermediate material (e.g., powder blend) or dosage unit. This capability is reinforced whenever an instrument reading outside the given specifications causes an equipment response (e.g., activation of a servo motor on a tablet press). Caution limits within the normal product limits are established purposefully to effect this kind of control.

Another level of control may be achieved with a tablet press by the proper positioning of each tablet tool with respect to its neighboring tablet tools. For example, the total tool length may become the basis for determining the relationship of each tool. The first step [16] is to grade each tool by measuring the total tool length (upper and lower) and putting the tools in order from the longest to the shortest. In the second step, the tools must be rearranged so that one revolution of the tablet press will yield a complete "sine curve." [Note: The sine curve designation is the result of a graphical representation of the tool station number on the x axis and the tool length on the y axis. The graph shows a maximum (longest tool length) and a minimum (shortest tool length), which are connected by an ever-changing tool length (minimum to maximum) from one compression

station to the next. This kind of special setup is especially needed when the output of the monitoring instrument does not develop an independent electrical signal for the compression force of a single station of the tablet press.]

Whenever this kind of activity becomes part of the manufacturing plan, the benefits of the setup-dominant process will be realized. This results because the quality standard, formed by the development function in the performance qualification, is carried over to the production setting. When production then incorporates this standard into its own operating procedures, the quality standard becomes a measurable criterion for performance. This example thus clearly shows how this phase of PV would be a QA tool for auditing.

When production develops an operation plan, it will include quality standards that complement the validation effort. These are as follows:

1. Equipment calibration. This quality function for production consists of a viable calibration program for equipment that provides in-process test data or a measurable indication of the controlled process used. This activity is needed so that the manufacturing unit will know whether the equipment is operating consistently during the time period covered by the calibration activity. This effort is also a continuing commitment of production to maintain its equipment as it was documented to perform during its installation qualification (IQ) and operational qualification (OQ) activities.
2. In-process testing and monitoring. Quality assurance of the production effort also occurs within its inspection plan, which it carries out through in-process testing. The generated data are often collected through the SPC system, but other activities come from in-process testing. The purpose of testing is to provide assurance that the ongoing process is yielding a uniform product and a consistently reproducible process. This effort is also useful when it becomes necessary to investigate the causes of defects or potentially out-of-control conditions.
3. Training of personnel. This quality function enables management to determine the real productivity level of its personnel, because productivity is no longer just measured in terms of units made; rather, it concentrates on the number of units made correctly. Training has been viewed as an element of PV, but the activity probably is more correctly interpreted as being a measure of the validation of an organization's personnel. Training thus really depends on the production environment of the company; that is, the company evaluates the personnel qualifications and responsibilities needed to carry out its operation and then works out a system to carry it out.

4. Development of standard operating procedures (SOPs). Training is achieved through the use of SOPs or operating manuals. The SOP is mainly written to provide a “how-to” approach for the activity it covers and to document that approach so that the audit activity will have a basis. Standard operating procedures complement the PV effort by ensuring that personnel will perform their work in a manner consistent with the objectives of the validation. These SOPs will normally cover the operation, cleaning, and calibration of the operating equipment as well as similar activities with test equipment and other control equipment. It should be noted that certain organizations prefer to have training guidelines perform what I’ve discussed as the SOP functions. In this case, the SOP will provide a high-level view of a function (or functions) with the training guidelines documenting the details.
5. Development of a logbook system. Logbooks are another QA vehicle that complements the PV effort. They are used to document any activity that involves the equipment they cover (e.g., cleaning or maintenance).
6. Use of clear, precise operating instructions, including the documentation of process performance and verification. A company’s system includes the issuance of a master production and control record and the batch production and control record (for each batch). These records document the fact that the company continues to manufacture each batch of product with the validated process of record.

These examples show how quality standards are established in production and how quality improvements may be sought. When PV is used as a QA tool, these quality standards enhance the potential for maintaining a validated process during routine production. They then will be the basis for QA confidence [4] that the quality function is being adequately performed in production.

### **C. Quality Assurance**

Quality assurance functions primarily to monitor the fact that the quality function is being performed. Its role in PV is readily associated with its main functions. For example, it performs the tests that demonstrate the product’s content uniformity. It may also perform the statistical evaluation of the test results to show that the process is reproducible. Quality assurance initiates the action to dispose of nonconforming product. It implements the inspection criteria and sets the specifications for product approval or rejection. It analyzes the product complaints to learn how effective its test program has been in preventing rejectable product from reaching the marketplace.

Quality assurance carries out the ongoing stability programs for each product at least once a year. It performs the physical and chemical tests that are used as the basis for approval or rejection of individual batches. In conjunction with setting specification limits as a basis for releasing or rejecting product, it will carry out programs to determine whether or not the new information indicates that a change in product or process has occurred. Finally, it performs the analytical tests that are used to generate the validation data required by the protocol.

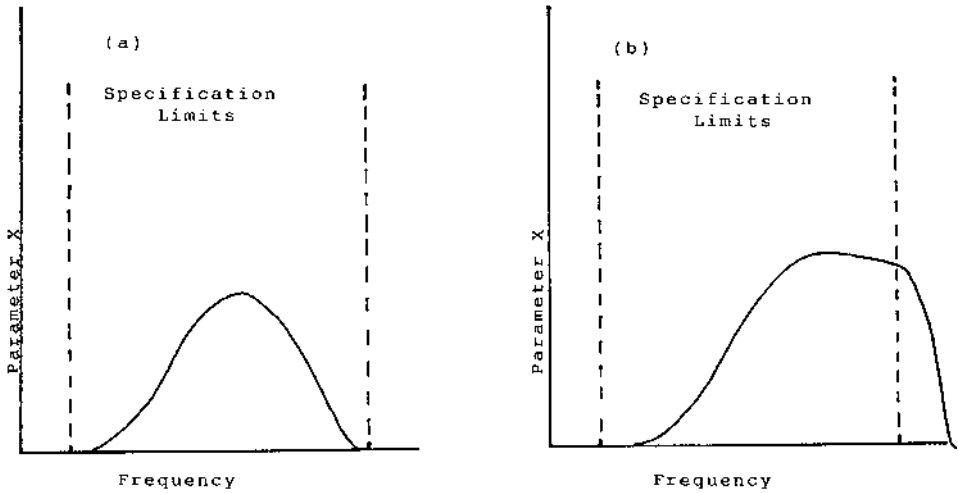
One approach that QA would use to assure itself that a given process (step) is under control is the effort associated with the concept of process capability. Ekvall and Juran [15] defined the concept as the measured inherent reproducibility of the product turned out by the process. The statistical definition of process capability is that all the measured values fall within a 6-sigma range (i.e., range of the minimum to maximum limits). The information is used to show that the process is under control over a period of time as well as determine whether there is any drifting or abnormal behavior from time to time. Process validation is a QA tool in this case because its data will be used as the origin for the data curve developed for the “process capability” concept.

This approach is made possible if the process (step) is demonstrated to be “under a state of statistical control.” A number of tests were listed by Ekvall and Juran to learn whether or not this condition exists. One approach to validating the technique involves the comparison of the process capability curve with the tolerance limits for the product. The intent of the validation is to determine whether or not the data from the process conform to the state of statistical control. It may also be used to determine whether or not quality costs can be reduced without changing the process’s status.

The technique involves superimposing the tolerance limits on the graphical representation (i.e., distribution curve) of the process capability curve. (See Fig. 1.) If the curve fits well within the tolerance limits, the inherent reproducibility of the process is considered adequate. If the width of the curve straddles the tolerance limits, however, the inherent reproducibility is considered inadequate. Finally, if the curve is skewed near the right or left limit, the model will predict that defects should occur.

In some respects, this technique is similar to retrospective validation [17–19]. Its value, however, is not as a type of retrospective validation but as a basis to require revalidation or suggest other options. The options would include the following: slightly modify the process, revise the tolerances, or sort the product to cull out the defects. Modification of the process may include any change in the process short of substituting a new one. Likely activities would include tooling changes (tablet presses), reordering of the sequence of the process steps, or replacement of certain equipment with a similar class type. It should be noted that while QA principles may allow such small changes, NDA filings might not, which means that such an activity would automatically result in revalidation work.





**Figure 1** Determination of process capability by graphical approaches. (a) Adequate process; (b) inadequate process control.

Revision of the tolerances is an option that may be limited, but it is possible, especially if the basis for setting them has changed. For example, tight tolerance limits for tablet hardness or friability may be set because the available data may require a conservative approach to set them that way. After data have been collected over a period of a year, however, the product experience may suggest that the tolerance range actually should be higher (or lower). The sorting of a product to cull out the defective units is another example of when a small change in process is needed. The approach has limited value, but whenever a validated technique to perform the sorting exists, culling out minor defects would be acceptable.

It should be pointed out that some organizations have a different role for QA, especially when the group is part of a quality control (QC) department. In such a situation, the regular QC group will handle the testing responsibilities, and a technical services group in QC will handle the data interpretation and other duties. Quality assurance then would be involved in audit activities of production, contractor operations, and so on. The main concern of a QA audit is that the written SOPs follow CGMP. The second concern is that the actual activities of production and contractor personnel directly follow the written SOPs. Any deviations from CGMP or SOP are recorded and reported to the audit unit. Corrective action is requested, and the completion must be deemed satisfactory by the QA audit team.

Finally, QA is the effort taken to ensure compliance with government regulations for the systems, facilities, and personnel involved with manufacturing products. Quality assurance audits will be quite varied in scope to achieve this assurance. These responsibilities include batch record reviews, critiques of product design, process validation activity, and, possibly audits of other departments' operations.

## **II. PROCESS VALIDATION AS A QUALITY ASSURANCE TOOL**

### **A. General QA Tools**

Up to this point it has been suggested how certain organizational activities might become QA tools, but PV should be considered the main QA tool because it not only involves the activities of many organizational units but also centers on proving that the process is under control. It provides documented evidence that the quality function exists for the manufacturing process. It is part of a series of QA activities [10] that pharmaceutical scientists have undertaken to determine objectively what grade of raw materials should be used, how well the materials should be formulated and processed, how well the products stand up during their shelf life, and how well the dosage form behaves in vivo. A brief description of these activities is given in the following:

1. *Raw material specifications and their acceptable limits.* All raw materials are tested before they are used in a pharmaceutical product. These materials must meet quality standards or meaningful specifications, and their limits must be set so that the use of unsafe, impure, and inefficacious materials will not be allowed in the product. The control labs will run the tests or have a contractor perform them, but QA will ensure that the lab procedures are properly followed and documented. Furthermore, QA will ensure that no raw materials were released improperly.
2. *Product specifications and their acceptable limits.* Quality assurance responsibilities are essentially the same for raw materials and final products. All finished drug products are tested to determine if they meet the required quality standards. These tests help to characterize the product so that the QA/QC function can determine whether or not the product has the proper strength and is safe, pure, and efficacious, yet these tests do not build quality into the product; rather, they are a measure of the product's quality.

An analogous situation exists for intermediate mixtures, such as blends or granulations. When these mixtures must meet preset specifi-

cation limits, pharmaceutical technologists have set them to make sure that the intermediates would meet the same standards that were established for raw materials and products.

3. *Product stability.* A stability program is undertaken to determine whether or not the product will maintain its quality characteristics throughout its shelf life. This effort includes studying the physical and chemical stability of the product under specific environmental conditions, such as ambient room temperature storage, as well as humidity, light, and heat challenges. In addition, its sterility (or microbial character) may be determined under certain conditions. Quality assurance will ensure that the stability profile for a raw material, bulk product, or packaged product is properly documented. In addition, it will ensure that final package labeling includes a statement of the expiration date, which is determined from the stability program. In this latter case, it may only be concerned that the test method used to show that the end is adequate.
4. *Bioavailability.* Bioavailability has become an important part of the QA effort to “prove” that the product maintains its strength, safety, purity, and efficacy during its shelf life. Since bioavailability was introduced, the scientist has not been satisfied with chemical equivalence between batches of product, and this expanded the QA effort. The study of bioavailability makes it necessary to know how the body’s physiology and biochemistry are affected by the drug molecule’s availability within it. The drug’s concentration in the body fluids, its ability to bind protein, its metabolic rate, its ability to present the active metabolite at the needed site of action, and the body’s excretion rate are the tools used to measure the drug’s bioavailability.

Knowledge about a product’s bioavailability thus enables the technologist to develop certain quality standards for that product. The concept of using the biobatch (i.e., a product batch used for clinical studies) as a reference enables the sponsor company to seek analytical methods that will show that later batches are similar to the reference batches.

5. *Training and documentation.* Responsibilities associated with PV and QA depend on the training of manufacturing personnel and the documentation of their activities. Such activities help to form the recognized quality standard that a pharmaceutical company builds for its products. These personnel are trained to carry out the standard procedures required by GMP documentation includes the write-up/revision of these procedures. Other records document how a batch of product is manufactured, whether unusual incidents or deviations occurred, the existence of reject notices, product complaints, and the investigation and analysis (as needed) of the above abnormalities.

6. *Process validation.* This activity is concerned with evaluating the manufacturing process. The undertaking adds an element of quality to the product, because it demonstrates what procedure must be performed and under what conditions the procedure must be carried out. It is often recognized that the equipment used and/or the process step itself may affect the product's bioavailability or its release specifications. Since the purpose of PV is to provide documented evidence that a process is reproducible and that it will consistently produce a safe, pure, and efficacious product, control of the manufacturing process makes it possible for the QA to be built into the product.

## **B. Purpose of Process Validation**

The kind of effort expended for PV is largely determined by organizational structure. Whether PV is managed by a department, a consultant, or a committee, the criteria for the program are still the same. These criteria will be examined by the responsible individuals so that the program will be tailored to the character of the process under study. The following questions are recommended in developing a suitable validation protocol or plan.

### **1. What is Being Validated?**

The answer to this question is important, because it is essential that the objectives of the validation activity be clearly stated. This understanding will enable the responsible group to plan the protocol and the test program needed to carry out the validation program. Quality assurance requires that the total PV document include the following [20]:

- Data on the IQ for the facility and equipment
- Data on the OQ for the facility and equipment
- An account of the understanding on each process step's capability
- Data generated during the processing activity and after its completion
- Documentation approval of the validation activity

Documentation of the IQ is important for QA so that the information will be available for future reviews by QA or the FDA inspector. There are three possible approaches that may be followed. First, the IQ information may be compiled as a stand-alone document to which other parts of the validation document would refer. The advantage of this approach is that the IQ doesn't get tied into a specific process or product validation. The second approach would have each validation document stand alone, which would mean that the IQ information on the equipment and facility would be repeated for every validation report. The third approach would combine the other two approaches; namely, that the facility IQ would remain generic and the equipment IQ would be a part of the

process/product validation document. Whatever approach is followed, the overall validation report must provide an effective QA tool. Quality assurance will thus strive to get the entire validation program documented in order to achieve its short- and long-term needs.

The PV of a new facility [21] must be documented in such a way to ensure that the facility's design and the operations within it are fully covered. An outline of such activities is listed in Table 4. For example, the validation of a new facility makes it necessary to document the equipment performance under relevant conditions. All process (or facility) equipment will undergo IQ testing to make sure that each piece of equipment operates as it was designed to do. The technologist will determine how the equipment's performance will vary without the influence of the process material (OQ). This information will form the basis for the remainder of the validation report. From a QA viewpoint, it should also be noted that this information might be useful if it is compared against the parameter measurements under load conditions. Since this information is more properly included in the performance qualification (as process optimization), however, it should not become a part of the validation protocol

On the other hand, if the process must be validated in an existing facility, existing IQ and OQ information may be adequate. In this case, the validation protocol might merely refer to the data rather than require its regeneration, especially when a credible calibration/audit program had been performed for the facility and equipment after the initial IQ and OQ were performed. This part of the validation work thus might merely be referenced in the validation document.

**Table 4** A Typical Validation Plan

---

1. Introduction
  2. Installation qualification
    - a. Facilities
    - b. Utilities
    - c. Equipment
  3. Operation qualification  
Testing protocols for utilities and equipment
  4. Validation  
Testing protocols for products and cleaning systems
  5. Documentation
  6. Validation of the QA testing laboratory
  7. SOPs
  8. Training of personnel
  9. Organization charts
  10. Schedule of events
-

The next concern raised by the question is the determination of whether prospective or concurrent validation is appropriate. This decision should be based on the nature of the PV activity. For a new facility, there is only one possible decision; namely, prospective validation. When certain process changes are made, however, it may be appropriate to choose the concurrent validation approach.

In December 1991, personnel from the pharmaceutical industry and academia (under the auspices of the professional organizations the American Association of Pharmaceutical Scientists and the U.S. Pharmacopeia Convention) collaborated with FDA scientists to hold a workshop on issues relating to scale-up activities and post (NDA)-approval changes. In particular, the workshop focused on oral solid dosage forms and the type of additional information that would be needed to document how the changes might affect the identity, strength, quality, purity and potency of product. The FDA also collaborated with its contractors (the University of Maryland Manufacturing Research, the University of Michigan and the University of Uppsala) before it issued the final guidance in November 1995, called "Guidance for Industry: Immediate Release Solid Oral Products, Scale-up and Post Approval Changes (SUPAC-IR)" [22]. A second document, called "SUPAC-MR: Modified Release Solid Oral Dosage Forms" [23], was issued by FDA in September 1997. A third document [24] was developed with the assistance of the International Society for Pharmaceutical Engineering (ISPE) and was issued as an addendum to the first two in January 1999.

These guidelines provide the industry with a tiered approach to generating PV data. The so-called levels of change are defined by the complexity of the process/facility/equipment changes that might occur in a plant or between plants. Generally speaking, these levels of change are defined as follows:

1. Level 1: changes that are unlikely to have any detectable impact on the formulation quality and performance
2. Level 2: changes that could have a significant impact on the formulation quality and performance
3. Level 3: changes that will likely have a significant impact on the formulation quality and performance

The FDA has indicated what test documentation it believes is needed to support a given change. It is interesting to note that certain sections of the guidelines might be considered a form of concurrent PV, especially in those instances in which the pharmaceutical company elects to inform the FDA of changes in its annual report format. Although the guidelines don't suggest the need for validation activity in certain cases, nothing prevents a firm from generating the data over a period of time (e.g., for a year) in accordance with its procedures.

For another example, when the initial data indicate that a process improvement does not adversely affect the statistics associated with process capability

but does warrant a change in the tolerance range, it is important for QA to ensure that the change in tolerance range does not adversely affect the overall product quality. It must also know that the newly proposed range will not float as new data are gathered. Concurrent validation would thus be an appropriate choice, and this would indicate how PV should be used as a QA tool. I refer the reader to the definition [26] of concurrent validation, which establishes “documented evidence . . . generated during actual implementation of the process.”

## 2. Why Should the Process Be Validated?

Personnel involved in the validation function will determine not only what will be in the validation protocol but also why the process will be validated. If a validation committee is responsible for the function, it will include personnel having varied backgrounds, such as production, engineering, process development, QA, and regulatory affairs. Likewise, the PV function would include personnel with these backgrounds or those who interact well with such individuals. When the technical details of the protocol require certain technical specialists (e.g., computer programmer), such an individual should be added to the group to fit the need. This multidisciplinary approach will help to develop a sound rationale for undertaking the validation program in the first place. In other words, the function is strongest when no one discipline dominates the effort; rather, it is the melding of each discipline’s input that gives the program strength.

It is important to avoid using a routine, predetermined menu when planning a validation protocol. The aforementioned SUPAC documents would be a helpful starting point when considering the “why,” however. In the ideal situation, the process development activities would dictate what tests would be included in the protocol and what ought to be the specification limits of the test results. Such activities form the basis for the data gathering because the large number of development batches, including the qualification and optimization trials, would clearly indicate why the specific parameters are being measured and why they indicate that the process is under control. When the validation protocol is the product of a multidisciplined team, it should thus not become a self-serving exercise of any single function.

For example, the QA function might accept the principles of testing for content uniformity, but then it might also introduce the concept that it wants all the test data to be within the product’s release limits so that the product’s shelf life stability would be ensured. This would thus give the group a broader reason for proceeding with this validation test, rather than merely looking for conformance to the USP content uniformity testing [20].

### 3. How Will the Process Be Validated?

The answer to this question determines the detailed activities of the validation protocol. It will state what tests will be used to determine if the process is under control. Furthermore, it will answer other questions, such as: How precise must the test results be before the specification limits will indicate when the process is reliable?

Should the worse-case scenario (e.g., a deliberate failure such as being at a level of 20% over the equipment's working capacity) be included to ensure the validation of the process? How many batches must be manufactured before the committee will consider the process validated? Will the initial production batch be considered the final optimization or the initial validation batch?

In addition to data gathering, QA will want the validation batches made entirely by the production department. When this stipulation is satisfied, it will be demonstrated that the process control is independent of the technical background of the operating personnel. This kind of approach demonstrates that the manufacturing process will support the soon-to-be-marketed product's volume demands. This approach also allows QA to have a baseline activity with which it can compare future audit activities.

### C. Qualification/Calibration Activities

Qualification activities are usually undertaken in order to characterize a facility's services and utilities as well as the equipment that would be used as part of a manufacturing process. As indicated earlier, these activities will include installation and operational activities as part of the validation function. Most companies will issue a report that documents the features of the facility's processing rooms, such as the electrical, water, gas, and HVAC services, for the installation qualification. [Table 5](#) is a generic outline of the items that would be found in the IQ report. Whenever the process equipment is permanently fixed in these rooms, the report will also list the equipment as well as its operating requirements and features. See [Table 6](#) for an outline of questions that would be used to complete a report, which includes equipment qualification. It is preferred that qualification occur as soon as the equipment or facility is ready for routine operation so that any unexpected results will be corrected by the equipment vendor and/or construction contractor.

The OQ report may also contain quantitative data generated from the testing of the facility and equipment. These activities are normally performed before the facilities or equipment are put into service.

The qualification reports are normally stand-alone documents and become a reference for many manufacturing process and PV reports. They also serve as



**Table 5** Generic Outline for a Qualification Protocol

---

- I. Room or facility
  - A. Description: Includes a statement of the wall, ceiling, and floor finishes, as they complement the process to be validated; e.g., listing of a nonporous wall finish (if wall must be chemically sanitized or sterilized) for sterile dosage form area.
  - B. Utility services
    - 1. Electricity: general description, including available amperage/volts services
    - 2. Gas supplies
      - a. Compressed air: description of supply equipment and pretreatment of air (e.g., filtration), range of pressure, standard of air quality to be routinely supplied
      - b. Other gases (e.g., nitrogen): description of its source, level of purity required, method of using it to achieve the desired performance, etc.
    - 3. Water supplies
      - a. Potable water supply, including a statement of its quality as supplied, and its treatment, if applicable, in house before use
      - b. Purified water, USP: list the method of generation and include the equipment used to prepare and supply it; description of the system, including the piping composition and finish; filtration equipment, storage containers; circulation standards; action limits for standards deviations (chemical and microbiological)
- II. Equipment
  - A. Description: name and appropriate identifier numbers
    - 1. Complementary equipment (e.g., process controllers or process monitoring equipment)
    - 2. Working capacity
  - B. Service utility requirements
    - 1. Electricity
      - a. Supply
      - b. Code status (e.g., explosion-proof requirements)
    - 2. Steam/hot water
      - a. Required heat range
      - b. Heating/cooling efficiency rate
      - c. Pressure requirements
    - 3. Compressed air/nitrogen requirements
      - a. Pressure range
      - b. Pretreatment needs, if any
      - c. Delivery needs, such as flow rate and volume for peak equipment efficiency.

---

**Table 6** Critical Items for Inclusion in a Qualification Protocol

---

1. Mixing/blending equipment  
The equipment's capability to blend material would be determined by asking the following questions:
    - a. What is the rotating speed, expressed in revolutions per minute?
    - b. What is the maximum weight that the equipment will be able to hold and process? How much volume will that load occupy?
    - c. What is the required tip speed of the equipment to effect the optimal blending conditions?
  2. The parameters for measurement of wet granulation equipment would include the following. Some would occur when the equipment is loaded, whereas other tests might occur when it is unloaded.
    - a. What is the tip speed of the main impeller blade?
    - b. What is the tip speed of the chopper blade?
    - c. How much "work" do both blades perform? For example, whether the driving force is measured by wattmeter, an ammeter, or a motor slip analyzer, it is important to determine how much work is expended in the process.
    - d. What is the shape of the equipment's process curve on a graph of work vs. time? Does it indicate the work end point when the electrical force (work) required for effecting the granulation reaches a plateau after a given time, or does the electrical force suddenly increase logarithmically in a short period of time to signal the end point?
    - e. Does the shape of the work curve vary with the load? Is it dependent on the volume of granulating fluid, or is it dependent on the rate of addition of the fluid? These parameters must be stabilized before the equipment's performance can be satisfactorily measured.
  3. The following questions should be posed to develop a protocol for qualifying milling equipment:
    - a. What type of mill is being evaluated? Does it have a fixed wheel, belt-driven operation? Does it have a varidrive gear operation?
    - b. How many operating speeds must be evaluated to determine the mill's process capability? Does the mill operate linearly, on the basis of mill speed vs. electrical input?
    - c. Through what kind of mechanism does the mill control the granulation's feed rate? Does the equipment have a process controller to coordinate the feed (input) rate with the mill speed? How does it work? How can the operation be monitored?
    - d. What test method will be employed to evaluate the equipment performance during the loaded and unloaded stages? Should a second method be employed to confirm the test data from the first method?
-

the basis for predetermined periodic calibration activities on the equipment. The existence of qualification reports and ongoing calibration logs enables QA to audit the upkeep of the facilities and equipment in a manner similar to the way it audits the validated process. Both documents thus not only support the PV effort but also help PV serve as a tool. The general sections of the qualification report include [21] an equipment description, a checklist of all critical items that need to be reviewed at the outset, vendor-supplied installation and operating manuals, as-built drawings of the facility and its design features, requalification guide, required preventive maintenance program, and specific instructions (optional) for operators within production.

With the emphasis I've given to planning throughout this chapter, the qualification protocol should be written in the same way. [Table 5](#) lists certain information that would be included, and it shows the same kind of checklist approach that was listed for the validation protocol.

The approach to the qualification work of drying equipment indicates an alternative approach to that described in [Table 5](#). Although the type of equipment would determine the exact program, the discussion below generally indicates the qualification needs for most drying equipment. The first step is to determine the heat distribution of an unloaded hot-air drying oven. For situations in which the granulation's residual moisture must be closely controlled, this information will become the basis for determining whether or not the oven can uniformly dry the material by applying a uniform heating environment over all the beds. If the oven cannot provide that uniform heating environment, it is improbable that the powder will be uniformly dried.

This information would be determined by measuring the heat and airflow at various points of the chamber and then calculating the variability of these conditions in it. Since this kind of information on heat distribution provides assurance that the process equipment is properly designed for the required process, it will be the focus of future QA audits. Furthermore, this knowledge is also essential when a very specific drying temperature is needed for thermally labile materials. The qualification thus not only becomes an integral part of the validation program, but also demonstrates how the information may be used.

Once the baseline data for heat distribution are established, the combination of in-process moisture analysis (of the load being dried) and heat or airflow distribution (for a loaded oven) will help the technologist understand the drying process for a product. In addition, other information learned will include the moisture level in the dried granulation can be reached without exposing the material to excess heat. This relationship will help QA evaluate the process during validation as well as audit the process if process deviations should be encountered.

The qualification of the sterilizing (aseptic processing) filter is another example of the requirements that are applicable for process equipment used in

the production of sterile dosage forms. This kind of qualification requires frequent repetition, however. It may thus prompt the reaction that the sample questions are not indicative of a qualification activity. Herein lies the element of QA in the qualification activity. While QA is part of every qualification, the nature of the process performed may require that the equipment be requalified wholly or in part each time it is carried out. The qualification questions that must be asked for these kinds of filters are listed in Table 7, but I leave to the technologist's judgment how frequently each must be answered. The literature has ample guidance for the validation of aseptic processing (i.e., sterile filtration), and a few examples are given in Refs. 25–27.

The value of qualification data—that is, as validation data and QA tool—shouldn't be underestimated. In an issue of the *Federal Register* [28], the FDA proposed “to require manufacturers to use a terminal sterilization process . . . unless such a process adversely affects the drug product.” The monograph clearly indicates what evidence is needed to support the manufacturer's position that it cannot use terminal sterilization, and it implies that the rationalization for using aseptic processing must be clearly stated and supported. It should thus be recognized that the QA utility of the qualification data might also be extended to FDA review and agreement.

#### **D. Process Validation Activities**

Originally there were three basic types of PV. They were generally called prospective, concurrent, and retrospective validation [29]. Each type represents a different pathway to concluding that a manufacturing process is in a state of control, yet it would be shortsighted to think that each type might be used only in a prescribed way. For example, if the protocol established for a prospective

**Table 7** Questions for the Qualification of Sterilizing Filters

- 
1. What composition and porosity must the filter medium have to effect aseptic processing?
  2. How must the filtering apparatus be sterilized to carry out the aseptic processing effectively?
  3. What kind of microbial challenge must be used to demonstrate that the equipment will work properly? Must the anticipated bioburden of the surrounding environment be considered?
  4. What kind(s) of product(s) will be processed by the equipment? What kind of retention testing is needed to prevent compromising the process?
  5. How will the bubble point test be run? What will be the conditions of the pressure hold test?
-

validation program states that three batches will be manufactured and tested, the data generated may not “provide evidence needed to establish confidence that the quality function was performed adequately” (Juran’s definition [4]). Indeed, the resulting product may meet its release specifications, but the validation data may not be tight enough for good statistical treatment. The validation committee will then withhold its approval until additional validation testing (i.e., concurrent testing for a given number of batches) is completed to establish the needed confidence. The final validation report will thus include data from the prospective and concurrent phases of the program in order to demonstrate that the process will do what it purports to do. In the previous edition of this book, a case was made for concurrent validation, but it may now be difficult to gain FDA approval of a new product by using this approach by itself. Food and Drug Administration speakers have encouraged sponsors to make multiple batches of an appropriate size to allow the completion of the PV effort for a product.

Using the concurrent validation technique to back up prospective validation data would be a proactive QA tool. Herein lies the challenge for the validation function in general and QA in particular. Do you use the tool? When an organization follows the precepts of TQM, the concept of continuous improvement would routinely be used. The validation function would ask: What is the expense of producing more than the originally planned number of batches? What validation effort is required to support the commitment to FDA that only a validated process will be used to supply product to the marketplace? Should TQM become the basis for concurrent validation? It would appear that concurrent validation is the logical answer. The counterpoint to this position, however, is that the batch size should be determined by the sponsor’s perceived need, and if smaller batch sizes are warranted, they ought to be sized accordingly to allow the production of multiple batches. Such an approach fits well with SUPAC concepts for validation and production. It probably also fits in with just-in-time production.

The main point of this example is that when PV is used as a QA tool instead of a final examination, an organization’s operations will improve or stay at the highest-quality level possible. The benefits from the effort will be sound documentation, and it might lead to an overall positive attitude among the affected personnel. Finally, a more logical approach to preapproval inspections and other FDA technical interactions will be effected. How then can the QA approach become part of PV?

## 1. Prospective Validation

This approach to validation is normally undertaken whenever the process for a new formula (or within a new facility) must be validated before routine pharmaceutical production commences. In fact, validation of a process by this approach

often leads to transfer of the manufacturing process from the development function to production. This approach thus allows PV to become the climax of a carefully planned developmental program. Recently, the FDA guidelines on pre-approval inspections, associated with NDA/ANDA submissions, added a new dimension to this type of validation. The FDA is seeking evidence that the manufacturing process is validated before it will allow a product to enter the marketplace [30]. I refer the reader to the article on prospective validation [11] for a more in-depth understanding of the technique.

The effort required for prospective validation makes it necessary that QA principles are satisfied. The effort should bring together all the technical functions: engineering, which documents and qualifies the process equipment, the facility, and the systems; production, which checks that its operating systems are working properly; QA, which builds on the database that had been accumulated during the development phase; and development, which certifies that its process performed as designed. In short, the objective of the work is to show that the product may be routinely produced with confidence.

It is necessary for QA to know what process conditions must be controlled and what variables must be monitored to show that the manufacturing process is controlled. These variables may be caused by the facility, the equipment, the process, the product's characteristics, or a combination of them. For example, in a case history [31] it was reported that a validated process had to be relocated in a production facility. The equipment used was rearranged so that the process would be more efficiently performed. Instead of operating the entire process on one floor, the tablet compression was performed on a lower level from the rest of the operation. The material's flow pattern required that totebins of the blended powder be located on the floor directly above the tablet press. This occurred by directing a tube from the totebins through the floor to the hoppers of the tablet press. The content uniformity data for the finished tablets indicated a greater variability than that experienced in the original facility. (See [Table 8](#).) Furthermore, the potency of tablets ejected from one side of the tablet press was routinely lower ([Table 9](#)) than that of tablets ejected from the other side. It is noteworthy that if this activity occurred today, such a change might be called a "level-3 change" for a manufacturing process.

Quality assurance wasn't satisfied with just having the data meet all the specifications or have a relative standard deviation below 6%. It was not confident that tablets in the batch with lower potency would be adequate to allow the normal expiration date for the product. Quality assurance thus did not agree that the process in the new area should be approved (i.e., validate, especially when data from the earlier blending process indicated a more uniform product.

Process development diagnosed the problem through a series of tests. It was determined that because the granulation was so potent when compared with the materials introduced during blending (approximately 90% vs. 23%, respec-

**Table 8** Content Uniformity Data from Old Facility

Drug content (mg/tab)		
Box	Left	Right
1	49.5	
2		49.9
3	49.2	
4		48.9
5	49.5	
6		48.4
7	50.0	
8		48.9
9	49.4	
10		49.1
11	49.1	
12		49.9
13	49.5	
14		48.9
15	48.7	
16		48.8
17	49.9	
18		49.5
19	49.7	
20		49.3
21	48.6	
22		48.8
23	49.3	
24		49.5
25	49.2	
26		50.2
27	48.7	
28		49.6
29	49.5	
30		49.6
31	49.4	
32		49.7
33	49.5	
34		49.4

Average: Left, 49.3 mg; right, 49.3 mg  
Total average: 49.3 mg  
Standard deviation (total): 0.43; relative SD: 0.87%

**Table 9** Content Uniformity Data from New Facility

Box	Drug content (mg/tab)	
	Left	Right
1	50.8	
2		49.8
3	51.4	
4		49.6
5	51.5	
6		48.9
7	50.9	
8		49.1
9	51.8	
10		48.7
11	51.9	
12		47.8
13	52.9	
14		49.9
15	50.5	
16		48.6
17	50.9	
18		49.1
19	51.8	
20		49.5
21	51.7	
22		48.4
23	50.2	
24		48.5
25	49.6	
26		48.6
27	49.8	
28		49.1
29	51.0	
30		48.7
31	50.4	
32		49.8

Average: left, 51.0 mg; right, 49.0 mg  
Total average: 50.0 mg  
Standard deviation (total): 1.46; relative SD: 2.92%



tively), the drug distribution in the coarse particles was much higher than in the fines. The drug distribution was no longer considered optimal in the new setting. The solution was that the milling should be slightly modified, and this yielded a more uniform drug distribution in the final powder blend (Table 9). This improved uniformity then yielded tablets that were equally good physically, yet more uniform than the product made in the original facility, and the process was validated. It was validated because using the modified process multiple batches yielded the same data and because it was also a clear case in which the science (i.e., technology) was used to support the position.

As I indicated earlier, prospective validation is used when a new chapter in manufacturing is about to be established. As such, it requires a sound game plan to document the transition from one stage to another (e.g., process development to full-scale production, the inclusion of new equipment, or the inclusion of a modified or new facility). The generated data must support the fact that the new process or facility ought to be used routinely in production. The successful validation provides the documentation that the developmental quality standards for the procedures and operations are adequate to manufacture a quality product in production. Finally, it becomes the basis for the quality standards, which must be maintained throughout the product's lifetime.

These benefits make prospective validation a QA tool, but QA is not a stagnant activity. It consists of snapshots of distinct activities, yet when all the snapshots are put together, a kaleidoscope of the life of a process and/or of a series of changes results. It may also include the investigative process, when a deviation occurs, and the corrections implemented to re-establish the validated state. To support such an effort, the trends shown by the data for each batch are documented. Prospective validation should thus be viewed as the anchor for the QA effort.

## 2. Concurrent Validation

This approach was first proposed in a public forum by Reisch and Chapman [14]. It was defined as “establishing documented evidence that a process does what it purports to do based on information generated during actual implementation of the process.” Potential applications of the approach are discussed later, and they are included because they demonstrate the need to use good pragmatic science and creativity when designing a validation protocol. They show that the protocol will very frequently consist of a series of validated in-process tests to monitor the process and product release testing to assure compliance with the product's specifications. The examples also indicate, however, that the protocol will require the kind of intensive testing that is normally associated with optimization and development. This approach should thus also be considered a QA tool if the activities are carried out in this fashion.

As indicated earlier, a case might be made to use concurrent validation if a firm wanted to validate a process, which under SUPAC guidelines would be reported to FDA as part of the firm's annual report. In fact, it should be noted that the definition of validation in the initial SUPAC document includes the statement, "The proof of validation is obtained through the collection and evaluation of data, preferably beginning from the process development phase and continuing through the production phase." If a firm wishes to follow this course of action, it is recommended that the strategy be discussed with FDA before it is attempted.

In a number of meetings, FDA representatives have discussed [30] the issues behind preapproval inspections and its *Guideline on the Preparation of Investigational New Drug Products* [3]. It is unclear, however, how extensively concurrent validation will be used in the future. On the one hand, it has been stated that NDA and ANDA products must be validated before their shipment into commercial channels will be allowed by FDA. Furthermore, in previous years FDA personnel had expressed their opposition to the concept of concurrent validation, saying that it was not a true validation activity. The guideline for IND products, however, does allow the collection of "data obtained from extensive in-process controls and intensive product testing [which] may be used to demonstrate that the instant [i.e., particular] run yielded a finished product meeting all of its specifications and quality characteristics." It thus appears that FDA does recognize that since the development stages do occur concurrently with clinical production, each stage must be validated either as a single batch or a combination of batches. This position seems to have resulted because many clinical programs do not consist of three batches of the same size, yet it is still necessary to demonstrate that the process, which yields a product for human consumption, is under control.

It should be evident that concurrent validation is especially useful as a QA tool. This approach to validation is useful to QA because it enables QA to set its own objectives as criteria for PV. For example, QA seeks to have every process validated. Most pharmaceutical products contain one or two active ingredients. Process validation is very straightforward for them; however, a whole new situation exists for a multivitamin/multimineral product. Innovative techniques are thus needed to achieve adequate validation.

It is intuitively recognized that with a multicomponent product the various active ingredients have to be mixed by a variety of techniques. There are no optimal blending conditions for each of the ingredients that can be tested to show unequivocally that the process step is under control. It is possible, however, to state that the process is under control if the various mixing steps preceding the final blend are shown to yield uniform premixes. The validation activity would then have to demonstrate that uniform premixes exist to yield a uniform final blend.

In our example, QA's objective is to feel confident that the manufacturing process will do what it is purported to do. It follows that the validation protocol should reflect the rationale for the chosen process. The recommended technique would be first to show how uniform the content of each active ingredient is after its incorporation in its own initial premix. The process of a typical vitamin–mineral product would include the separate wet granulation of the minerals, water-soluble vitamins, and fat-soluble vitamins. Alternatively, if granular forms of the water-soluble vitamins were available, they would be mixed as a premix. Inert carriers are often used to disperse the fat-soluble vitamins. The uniformity of the mixes would be demonstrated by testing (with content-uniformity tests) for the ingredients, which have the lowest potencies in the respective premixes. The same ingredients would be the objectives for the content-uniformity testing of the final blend. From the QA perspective, this approach utilizes markers to demonstrate not only that the premixes are uniform but also that they are blended together uniformly before tablet compression.

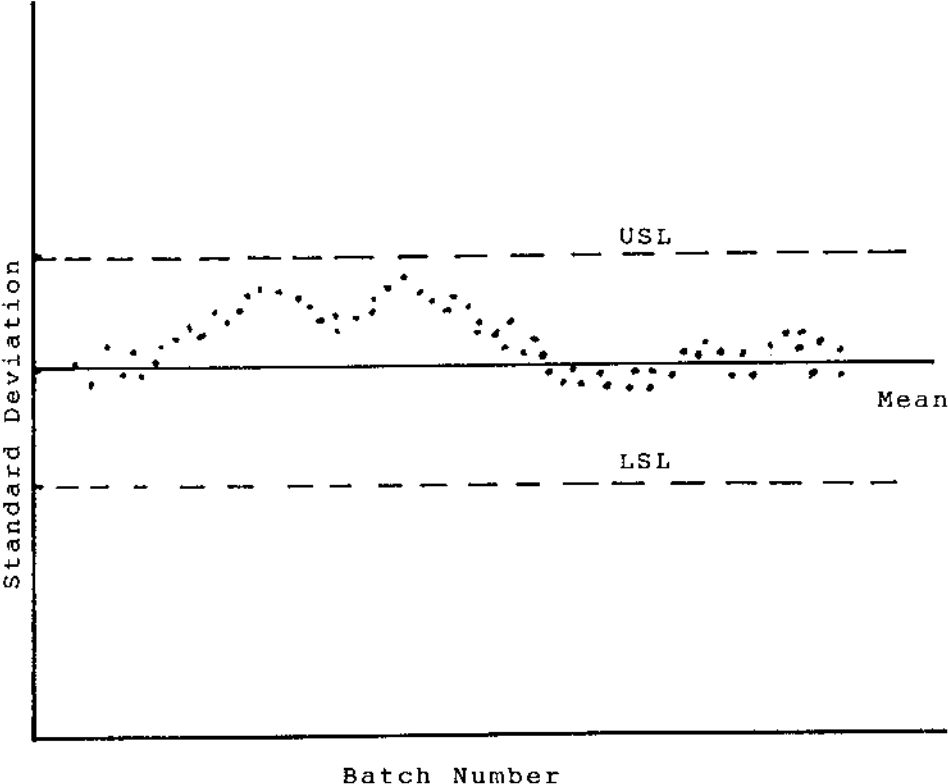
After tablet compression, content uniformity testing is recommended for each active ingredient, taken from at least three samples of the batch. If coating is included as a process step, the coated tablet would then be tested according to the normal product release testing. In effect, uniformity would not be an issue for the coated core, but it would be important to know that the final product meets its specifications.

This kind of test program admittedly is very intensive, but the nature of the testing makes it appropriate for validation testing. Furthermore, if the analytical tests themselves and the testing of so many ingredients don't give a clear analytical understanding of the validation status with three batches, the program can always be expanded to six or more batches. The point is that concurrent validation would be appropriate for this kind of situation because it would provide assurances that each batch meets not only its release criteria but also its validation criteria. Such a program would thus allow QA to release each batch on its own merits rather than wait for a group of batches to demonstrate the validated state.

Another case for concurrent validation is that effort that requires statistical (and possibly trend) analysis. It is appropriate to digress and explain what is meant by trend analysis. This activity really consists of product auditing, which is described in more detail elsewhere [32]. Product auditing is a QA (management) technique in which each batch's analytical data provide "a running scoreboard of product performance." The quality standards would be measured periodically (monthly, quarterly, or semiannually), which would depend entirely on the number of batches made per time interval. At least six batches would be made in the same manner per chosen time interval. The data would be measured, and then it would be determined (through charting the data) if the data fell between predetermined specification limits. Each new period's data would be

compared with the data trend that developed before it. Deviations, which led to a change in the trend, would be investigated. If the deviation was not caused by a change in process, further investigation and troubleshooting activity would be required.

Figure 2 demonstrates how trend analysis would be used. The standard deviation of data for a series of batches is plotted against their control (or batch) number. The graph resulting from the dotted points indicates a trend toward the upper specification limit for the test parameter, but the trend later returns to the mean level. If one merely looked at the tabular form of the data, one would not necessarily conclude that there is a problem. It is only when the data are graphically represented that the trend is seen. This would lead to an investigation into the possible causes of the trend. There is another very helpful application to



**Figure 2** Simulated data representing the trend analysis technique.

trend analysis. The approach may be useful when a series of minor process changes are implemented while gathering the validation data for approval of the final process. In this program, it is necessary to identify all the changes in process characteristics with the data generated. This effort may demonstrate that a change in process step controls the overall process, but if it doesn't, the ability to produce data to show statistically that the process is under control makes the approach worthwhile. It should be noted that this technique again enables QA to release each batch after its data are analyzed, yet it is flexible enough to allow the evaluation of data from more than one batch whenever necessary.

These examples demonstrate that when PV is treated as a QA tool, good management is a necessity and a reality. In each of the situations described, data generation is the key. Other requirements include the need for routine data analysis and sound project management and the need for immediate decisions on change control procedures, supplemental NDAs/ANDAs, and preparations associated with preapproval inspections. Other examples, which show that concurrent validation is a viable option, include validating a process in which a step is modified or the vendor of an inactive ingredient is changed, or instituting changes for a product that is made infrequently. The last example may be too difficult to support, however, unless it is demonstrated that the change had no impact on the product quality and performance (e.g., a level-1 change for components or composition).

An example of the modification of a process step is the effort to validate a process when a coating process or coating solution formula undergoes major changes. A second example is the introduction of new tooling for a tablet product. In this program, tablet appearance or weight variation might be affected, and this testing would be all that is needed to demonstrate that the process is under control.

An example of component change is the effort needed when a new raw material (active ingredient) must be introduced. First, this raw material would have to meet all the existing specifications for its established counterpart. If earlier experiences with the original material had shown a cause-effect relationship between the process and the material, it would be appropriate to do concurrent testing to show that the use of the new material is validated. In this type of validation, QA would require that the product undergo a limited stability program before it is released for marketing. For example, this objective of the program may be achieved by a "3-month accelerated stability" program or a "6-month ambient room temperature" program. After the data are reviewed, the decision to release the product would be made and the normal stability program would continue until the product's expiration data is reached.

An example for a change in the product involves the use of a normal validation test program on a limited number of batches. Certain products may have limited batching requirements over a 6- to 12-month period. In this case,

the original batch would be kept from the marketplace for an inordinate period of time. The important thing to remember is that the batch should be tested using a preplanned written protocol and that the test data be reviewed and approved immediately after each of the batches is made.

When the concept of concurrent validation is embraced by an organization, it is important for everyone to support QA's use of it as a QA tool. The quality standards of each discipline are normally stressed because of the normal commercial pressures, but it is essential that overall QA not be relaxed. The validation format in general and concurrent validation in particular will allow the flexibility needed for the situation, yet, it also provides the vehicle for a disciplined approach to ensure that no unacceptable product will be released.

### 3. Retrospective Validation

Retrospective validation has become synonymous with achieving validation by documenting all the historical information (e.g., release data) for existing products and using that data to support the position that the process is under control. It was originally discussed in a public forum by Meyer [16] and Simms [17]. I also refer the reader to articles in the first edition of *Pharmaceutical Process Validation* [18].

This approach to validation is the clearest example of validation being a QA tool. It appears that this approach will rarely be used for validation today, however, because it's very unlikely that any existing product hasn't been subjected to the PV process. The technique may only be justifiable if it is used for the audit of a validated process. With retrospective validation, the generated data already exist, but must be documented in a manner that clearly demonstrates that the existing process is under control. Quality assurance must first outline a plan for the validation effort, however, which would include the following items:

1. A quality audit of the process as it relates to the resulting product. It is necessary to categorize the process history chronologically. Then the change control history must be superimposed on the historical information.
2. A collation of the in-process control and product-release data according to batch number.
3. Pairing of these data with the change control history. It has been pointed out by many individuals that it is not sufficient merely to collect the data. First, one should identify and document the major changes in the product and/or process over the lifetime of the product. Once the data of each process phase are identified, the data may be used to show the overall integrity of the specific process.

4. Determining which changes are significant. Many types of changes would qualify, including a change in specification limits for the process change, a formula change involving the active ingredient or a critical excipient, a facility or equipment change, and a change in the limits of criteria for process control. The data associated with each process change must support the fact that the process is under control.
5. Grouping the data and statistically analyzing them. For example, trend analysis or some other acceptable statistical approach may be used to evaluate whether or not process control has been demonstrated.
6. Determining whether or not data associated with earlier significant changes also demonstrate a controlled process. This effort assumes that enough data are available for each stage. In effect, the effort establishes the documentation to declare a continued validated state for the various processes used during the product's lifetime. The approach may be similar to the one taken for concurrent validation, except that the analysis occurs with data that are on hand. It is preferred that a large number of batches (10 to 20) are included, but the historical data may not be adequate to do this. I have since learned that as few as six batches may be used to represent each process change.

A second application of retrospective validation would be the effort to validate a process having a minor change; for example, purchasing requests that a second vendor be established for a given raw material. This material is an excipient, it meets all of the existing specifications for the established raw material, and there is nothing that singles out the new material as being different. In this situation, it would be prudent to plan to qualify the material through a monitoring system. Classifying this effort as retrospective validation is not clear-cut. It is amenable to trend analysis treatment, however, which is effective as a proactive or passive technique.

#### 4. Revalidation

It may appear that some of the aforementioned approaches to validation be viewed as revalidation activities. Allow me to digress so that I can share my views and those of others [33] on revalidation. Revalidation indicates that the process must be validated once again. It may not necessarily mean that the original program must be repeated, however. In fact, if PV is viewed as a QA tool, the requirements for QA will dictate how revalidation is carried out.

First, revalidation may mean that the original validation program (e.g., a prospective program) should be repeated at a predetermined frequency. Second, the retrospective validation approach may be used for a manufacturing process even though it was originally validated in a prospective manner. For this to

happen, sufficient data would have been generated for the mature process to allow treatment in the retrospective manner. In a third situation, there may merely be movement of equipment to improve materials handling, which might require that the concurrent approach to validation be undertaken. I believe that the concept of QA is satisfied in every one of these situations, especially when it is integrated into a TQM program.

Process validation will be seen as a QA tool because it fits into the functions that QA performs. Process validation also benefits from the QA efforts of the other technical units in the company, however. Gershon [34] discussed Deming's concept of TQM and indicated that it consists of three phases. First, a cultural environment must be developed within an organization. Second, SPC fundamentals must be put into place. Third, statistics must be used to develop process controls and to assist management in running complex processes in an optimal manner. Revalidation thus fits very well in the company's TQM program.

In other words, the QA benefits of a sound PV program include the following:

1. Sound data are developed by process development to determine the process capability and optimize the overall process.
2. This becomes the basis for ongoing data development from routine batching activity and process controls.
3. It serves as the reference for comparison when investigations of process deviations are needed and corrective action must be justified.
4. It will also serve as the basis of audit activities, such as trend analysis and change control procedures.

Many statistical tools are available to QA to analyze the process data. The quality of analysis is improved when the database adequately represents the controlled process. For example, trend analysis is useful in determining whether a process change or deviation has occurred. If a good data history exists for the developmental, clinical, and early production stages, QA will have some basis for evaluating changes that might occur subsequent to scale-up activities. When the data from these stages do not show a perceivable change, it may be possible to discount batch size as a cause of the perceived problem in production. A sound database will thus be useful for problem solving as long as enough data are collected on a routine basis.

Data collected for each process phase may also be evaluated statistically to evaluate objectively whether a process change was better or worse than the preceding one. For example, through analysis of variance, it would be possible to determine whether each process phase had demonstrated continued process control or clear improvement. The revalidation approach would thus allow the QA (or production technical services) group to proactively manage its responsi-



bilities for production support, troubleshoot a process, and/or set up a plan for more revalidation activities.

In my earlier comments on revalidation, I gave examples that might occur because of QA concerns. The following situations might also affirm that QA must be supported by a revalidation activity. In one case, an investigation would be requested if product release data showed a significant shift from the population's mean. The use of a second QA tool might also be recommended; namely a short-term stability study to check for any changes in the stability profile. In another case, a QA audit might indicate that confidence in a process should be questioned because newly acquired data suggest that the process is out of control. Again, the recommended corrective action might be that revalidation of the process will occur because of any one of a number of circumstances. Quality control thus results from the QA effort. In other words, QC rests on the effort to implement action procedures when "trigger events" occur.

## **E. Miscellaneous Issues**

Earlier I discussed a method of planning for PV, in particular the overall development function leading up to it. It appears that the development group has a number of avenues that will lead to the appropriate validation approach it takes. In one approach, the critical process parameters would be measured to monitor the process and document the fact that the process is validated. Many validation programs use this approach, but they are usually undertaken right after or as part of the "technology transfer" effort.

Kieffer and Torbeck [35] published a paper that asserted that test results from three validation batches are insufficient to provide the high degree of assurance that is required by the FDA's definition of validation. They indicated that process consistency, which yields a product having predetermined quality attributes and having its specifications met, is more appropriate. Nally and Kieffer [36] had earlier maintained that the well-established statistical measurements for process capability are excellent for quantifying the (required) degree of assurance. Kieffer [37] also stated that the acceptability of the degree of assurance should be relative to the risk versus benefit for the measured quality characteristic. This series of papers indicate that the development effort would be greatly enhanced if data collection centers on process tests that show the process to be within the limits of process capability. The second benefit for such an approach may lead to another application of parametric release testing.

Parametric release testing was defined by the European Organization for Quality [38] as "an operational alternative to routine release testing where samples are taken from every finished batch for testing in accordance with the release specifications." This approach has been used successfully in Europe and the United States for a validated terminal sterilization. The European Pharmaco-

poesia was quoted in this reference as stating “When a fully validated terminal sterilization method by steam, dry heat or ionizing radiation is used, parametric release, that is the release of a batch of sterilized items based on process data rather than on the basis of submitting a sample of the items for sterility testing, may be carried out, subject to the approval of the competent authority.”

It remains to be seen how long it will be before this principle is applied for the tablet manufacturing process. The guideline suggested that parametric release may be introduced after a variation of an existing approved product is introduced and more experience is gained with it. It would be wise, however, to make such an approach a collaborative effort with the regulatory agency that has jurisdiction over the product’s certification. In other words, if the approach seems to be the way your validation program ought to go, consult the local regulatory group and/or work with other pharmaceutical scientists.

Another approach would be to look at the worst-case challenge. An example of this approach is the challenge involving the termination sterilization of products. The widely accepted technique [39], commonly called the “overkill approach,” is used for products that can tolerate heat. Such a technique minimizes the need to test the product for bioburden and for the minimum lethal conditions for that microbial load. The rationale for the approach is that when a process can be demonstrated as effective even for the most challenging conditions that will be encountered during normal processing, the process will be considered validated for routine use. The technique thus enables the technologist to know how effective the process is (for each batch of product processed) just by knowing how much heat was applied to the product and how long the heat exposure was.

It should be noted that bioburden testing (or viable counts) is an integral part of environmental testing, and it is very useful information to complement the effort to validate heat sterilization. The FDA position on terminal sterilization [27] supports the correctness of this statement.

On the other hand, the worst-case challenge for solid dosage forms is more difficult to define, especially if the process in question is very robust. An example of applying the worst-case challenge to the validation of a blending operation is studying the effect of increasing the batch volume by 20%. In one case, the increase might exceed the total working capacity of the equipment; in another case, both batch sizes would fit within the equipment’s working capacity. In the former instance, it would be very likely that a rejected batch would be produced, but in the latter it would be likely that two acceptable batches would be made when the same process conditions are employed.

The quality of the development effort would be enhanced if the routine scientific activity looked at the worst-case situation. First, the process characteristics would be better understood. Second, the specification limits for the in-process tests would be based on hard data. Third, it would be easier to evaluate

the process capability of two different-sized pieces of equipment performing the process activity under the same conditions. Finally, it might be possible to validate the same production-sized process of multiple batch sizes with one program in the plant.

The inherent value of PV to the production department is based on QA. From the time when the validation protocol is accepted to the time when the process is judged to be validated, the increasing value is due entirely to QA. With the availability of validation data, production has a basis of comparison whenever the quality standard of the process must be checked. First, it represents an opportunity to utilize the principles [40] of TQM, which seek to prevent crises rather than react to them. Second, it allows production to become totally involved rather than consider quality someone else's concern. Third, it emphasizes an attitude for continuous improvement throughout the department by focusing on the process rather than the end product. Fourth, an environment is cultivated for managing with facts, not intuition. Finally, it assists personnel in seeking excellence rather than settling for something that is just good enough. When these benefits are incorporated into the way production operates, there will be an incentive to incorporate parametric release concepts and other QA tools in their daily activity, because costs may be reduced.

Quality assurance prevails when the data generated in the validation program provide a good basis for SPC in production. If the concept of SPC becomes a part of personnel training, personnel will not only learn what in-process tests are run but why they are being run and why the desired corrective action must take place. It also encourages the personnel to report suspected problems early and seek assistance to correct the unusual problems when they are occurring. It is frustrating to investigate data from a number of batches and then learn that the same problem was occurring in every one of them. What is done cannot be undone; that is, why try to build quality into a batch after all the production effort is completed? Statistical process control has proven itself to be an effective cost-control mechanism for the organizations that have implemented the program. There is no reason to believe that the other aforementioned tools won't have the same effect.

Another aspect of QA is seen whenever PV data may also be used as the basis for problem solving. It may be necessary to design a series of experiments to learn which control parameters are contributing to the problem. If the study enables the validation group to understand the causes better, then the decision to requalify and/or revalidate the process will be based on sound statistical principles. Effective problem solving will thus require effective validation and a good investigative follow-up.

The final benefit of validation activity (or QA) requires that production's facilities and equipment be qualified to certify their ability to perform as expected for the validation batches and routine production. Qualification proce-

dures form the basis of production's ongoing calibration program. Documentation of the periodic calibration activities will provide an adequate record if the information must be used to explain any changes in process. When this information is coupled with other equipment logbooks, a proper history is available for QA audits.

### III. SUMMARY

This chapter has shown how PV and QA are related. Process validation is a QA tool, because it is used by QA to document validation activities, but it is also a part of the entire organization's effort to maintain QA. When the validation activity becomes the focal point of an organizational unit's effort to carry out its own technical responsibilities, quality standards will be maintained for the product and manufacturing process from the design and development stages and throughout the commercial life of the product. For example, the need for QA in development work makes it possible to make PV a goal of that work. It assures that PV will be the basis for the periodic quality auditing of the manufacturing process throughout its existence. It requires that formal change control procedures must be closely followed by every organizational unit. It allows PV to be used as the basis for the investigation of abnormal occurrences and for the corrective action taken. Finally, it assures that all the organizational functions will undertake revalidation activities for prescribed situations rather than react to crisis situations. This chapter has demonstrated how such benefits may be realized.

An attempt was made to show how PV is a QA tool in the sense that it enables the technical departments to manage the quality function in their disciplines. For example, the development group may use it to challenge its understanding of the development process. It may also use it to gauge the quality of the individual contributor's work. The production unit may use it as a basis for accepting the process as well as continually evaluating the existing process over time, which makes it a part of production's quality plan, which may also lead to the improvement of its quality systems.

### REFERENCES

1. Loftus, B. T. The regulatory basis for process validation. In: B. T. Loftus, R. A. Nash, eds. *Pharmaceutical Process Validation*. vol. 23. New York: Marcel Dekker, pp. 1-7 (1984).
2. Nash, R. A. Introduction. In: I. R. Berry, R. A. Nash, eds. *Pharmaceutical Process Validation*. vol. 57. New York: Marcel Dekker, pp. xiii-xli (1993).

3. U.S. Food and Drug Administration. *Guidelines on the Preparation of Investigational New Drug Products (Human and Animal)*, Washington, DC: U.S. Dept. of Health & Human Services (March 1991).
4. Juran, J. M. Section 2: Basic concepts. In: J. M. Juran, F. M. Gryna, Jr., R. S. Bingham, Jr., eds. *Quality Control Handbook*. 3rd ed. New York: McGraw-Hill (1974).
5. Juran, J. M. Section 3: Quality policies and objectives. In: J. M. Juran, F. M. Gryna, Jr., R. S. Bingham, Jr., eds. *Quality Control Handbook*. 3rd ed. New York: McGraw-Hill (1974).
6. Nash, R. A. The essentials of process validation. In: M. A. Lieberman, L. Lachman, J. B. Schwartz, eds. *Pharmaceutical Dosage Forms*. 2nd ed., vol. 3. New York: Marcel Dekker, pp. 417–453 (1990).
7. Bader, M. E. Quality assurance and quality control (in four parts). *Chem Egr* (1980); see Ref. 4.
8. Jeater, J. P., Cullen, L. F., Papariello, G. J. Organizing for validation. In: I. Berry, R. A. Nash, eds. *Pharmaceutical Process Validation*. vol. 57. New York: Marcel Dekker, pp. 9–24 (1993).
9. Rudolph, J. S. Validation of solid dosage forms. In: I. Berry, R. A. Nash, eds. *Pharmaceutical Process Validation*. vol. 57. New York: Marcel Dekker, pp. 167–188 (1993).
10. Rifino, C. B. Validation of new products and new processes: A view from process development. PMA Seminar on Validation of Solid Dosage Form Processes, Atlanta, 1980.
11. Chao, A. Y., St. John Forbes, E., Johnson, R. F., von Doehren, P. Prospective process validation. In: I. Berry, R. A. Nash, eds. *Pharmaceutical Processing Validation*. vol. 23. New York: Marcel Dekker, pp. 227–248 (1993).
12. Rifino, C. B. A philosophical view of certain personnel considerations in validation. Purdue University Management Conference for the Pharmaceutical Industry: Regulation, Legislation, Economics and the Drug Industry, part II, 1979.
13. Reisch, R. G., Chapman, K. G. Process validation—industry's viewpoint. In: *Pharmaceutical Technology Conference '84 Proceedings*. Springfield, OH: Aster, pp. 92–101 (1984).
14. Ekvall, D. N., Juran, J. M. Section 9: Manufacturing planning. In: J. M. Juran, E. M., Gryna, Jr., R. S. Bingham, Jr., eds. *Quality Control Handbook*. 3rd ed. New York: McGraw-Hill (1974).
15. Howe, D. in-house communication.
16. Meyer, R. J. Validation of products and processes from a production, quality control viewpoint. PMA Seminar on Validation of Solid Dosage Form Process, Atlanta, May 1980.
17. Simms, L. Validation of existing products by statistical evaluation. PMA Seminar on Validation of Solid Dosage Form Process, Atlanta, May 1980.
18. Trubinski, C. J. Retrospective process validation. In: I. Berry, R. A. Nash, eds. *Pharmaceutical Process Validation*. vol. 57. New York: Marcel Dekker, pp. 249–297 (1993).
19. Steinborn, L. *GMP Quality Audit Manual*. Buffalo Grove, IL: Interpharm, Chap. 2 (1991).

20. Falkow, M. Overview of a new facility validation effort. Eighth Annual ISPE/FDA Joint Conference, Case Studies in Validation. March 14–16, 1989.
21. U.S. *Pharmacopoeia*. XXII/NFXVII. Rockville, MD: USP Convention, p. 1618 (1990).
22. U.S. FDA. Guidance for Industry, Immediate Release Solid Oral Dosage Forms (Scale-up and Post Approval Changes: Chemistry, Manufacturing and Controls, In Vitro Dissolution Testing, and In Vivo Bio-equivalence Documentation (Nov. 1995).
23. U.S. FDA. SUPAC-MR: Modified Release Solid Oral Dosage Forms. Center for Drug Evaluation Research (CDER), (Sept. 1997).
24. U.S. FDA. Guidance for Industry, SUPAC-IR/MR: Immediate Release and Modified Release Solid Oral Dosage Forms. Manufacturing Equipment Addendum (Jan. 1999).
25. Levy, R. V., Souza, K. S., Neville, C. B. The matrix approach: Microbial retention testing of sterilizing-grade filters with final parenteral products. part 1. *Pharm Tech* 14:161–173 (1990).
26. Levy, R. V., Souza, K. S., Hyde, D. L., Gambale, S. M., Neville, C. B. Part 11. *Pharm Tech* 15:58–68 (1991).
27. Hardwidge, E. A., Chrai, S. S., Dawson, E. W., Radowitz, C., Meltzer, T. H., Zeronsa, W. P. Validation of filtration processes for sterilization of liquids. *J Parenter Sci Tech* 38(1), 37–43 (1984).
28. *Fed Reg* 56(198), 51354 (Oct. 11, 1991). See 21CFR Part 211 et al.
29. Chapman, K. G. Validation terminology. In: I. Berry, R. A. Nash, eds. *Pharmaceutical Process Validation*. vol. 23. New York: Marcel Dekker, pp. 587–597 (1993).
30. Phillips, J. Headquarters perspective of the new inspection program. Proceedings, Fifteenth International GMP Conference, University of Georgia, March 18–21, 1991.
31. Rifino, C. B. Process validation of solid dosage forms. Interphex '86, session 7 (Validation of Production Methods for Solid Dosage Forms), New York, 1986.
32. Juran, J. M. Section 21: Upper management and quality. In: J. M. Juran, E. M. Gryna, Jr., R. S. Bingham, Jr., eds. *Quality Control Handbook*. 3rd ed. New York: McGraw-Hill, (1974).
33. Jeater, J. R., Cullen, L. F. Revalidation: How, when and why. Pharmaceutical Technology Conference '82, New York, Sept. 21–23, pp. 126–138.
34. Gershon, M. Statistical process control, *J Parenter Sci Tech* 45:41–50 (1991).
35. Kieffer, R., Torbeck, L. Validation and process capability. *Pharm Tech* 22(6): 66–76 (1998).
36. Nally, J., Kieffer, R. The future of validation: From QC/QA to TQ. *Pharm Tech* 17(10):106–116 (1993).
37. Kieffer, R. Validation, risk–benefit analysis. *PDA J Pharm Sci Tech* 49(5):249–252 (1995).
38. Committee for Proprietary Medicinal Products. EMEA Draft Guidance on Parametric Release—C. Int. Pharm. Regulatory Monitor, Lanham, MD (May 2000).
39. Parenteral Drug Association. Validation of Steam Sterilization Cycles. technical monograph no. 1.
40. Benson, T. E. The gestalt of total quality management. *Indus Week*: 30–32 (July 1, 1991).

# 22

## Validation in Contract Manufacturing

**Dilip M. Parikh**

*APACE PHARMA Inc., Westminster, Maryland, U.S.A.*

### **I. INTRODUCTION**

#### **A. Outsourcing**

Within the last 10 years the pharmaceutical industry has faced a tremendous amount of pressure on dual fronts. The inventory of the new drug molecule is running low, and the health care marketplace is exerting pressure on the industry to contain the costs of medicine. The industry is struggling to replenish the dwindling drug molecule pipeline. The impact of these pressures on the pharmaceutical industry is evident in the mergers and acquisitions that have taken place in the last 10 years. Governments and managed care organizations in major pharmaceutical markets have imposed price restrictions on prescription drugs. In the United States, the use of managed health care not only has affected the way pharmaceutical companies approach the sales of products and pricing factors, but also has forced many of them to adopt a very different long-term strategy. As of the year 2000, 18 blockbuster drugs were scheduled to lose their patent protection within 5 years. This will affect \$37 billion worth of the current \$300 billion ethical pharmaceutical market. The increase in competition from generic products has been significant in many national markets. The effect of patent expiry for a particular product has become much more marked, with many products losing more than 65% of sales revenue with the onset of generic competition. As a result, pharmaceutical companies are under escalating pressure to significantly increase the number of new drugs that reach the market and to do so in a shorter period of time. For a projected \$100 million product,

a 1-month delay in commercializing or launching can result in a sales loss of more than \$8 million.

These changes have forced internal restructuring in the industry. In many pharmaceutical companies, executives have scrutinized the areas that have traditionally absorbed a high proportion of their budgets, and rationalization is becoming more common. Many companies recognize that they can no longer master the entire spectrum of skills and have focused on core competencies within the organization. Many areas of expertise are not required on a permanent basis, and instead may be contracted out by the company at a certain point in the long process of bringing a product to market. This has driven the growth in the outsourcing of nearly every service within the industry. Lately, there has also been movement within some major pharmaceutical companies to sell the manufacturing plants to an outsourcing organization and only concentrate on basic molecular research, development, and marketing.

The other driving force that has propelled the outsourcing concept to the forefront is the formation of “virtual” companies. The concept of the virtual corporation is based on the assumption that pharmaceutical companies can outsource almost every aspect of their operations to form a business that has very close links with its external suppliers but is nonetheless a separate entity. Taken to its logical conclusion, the pharmaceutical company could consist simply of a head office containing the core departments and the key decision makers.

Outsourcing has been used the longest in those areas of the pharmaceutical business traditionally held to be the less important parts of the value chain (Fig. 1).

At the simplest level, outsourcing is the contracting of services or tasks to an external company. Increasingly these outsource companies possess better-developed skills in the particular area and a reduced cost structure in comparison to the client companies. Outsourcing fits well with the just-in-time (JIT) concept of minimizing waste in a company’s operations. In theory, outsourcing much of the company’s activities should allow it to minimize the effects of fluctuating revenues in what has become a more dynamic business environment. Generally, development and marketing activity tends to be cyclical in most pharmaceutical companies. Outsourcing therefore allows the company to maintain a basic level of operations in core departments but expand or contract out in areas in which additional resources are required. This can be done on a project by project basis. The range of activities for which pharmaceutical companies have outsourced

**Research ⇒ Development ⇒ Production ⇒ Marketing ⇒ Sales ⇒ Distribution**

**Figure 1** Pharmaceutical industry value chain.



has expanded substantially. All indications are that this trend will continue. The list below shows the types of activities currently outsourced, as well as future possibilities.

## **B. Activities Currently Outsourced**

- Synthesis of active ingredients
- Preclinical testing
- Formulations development
- Phase I, II, III, and IV clinical trials
- Clinical trials supplies manufacturing
- Clinical packaging
- Clinical trials data management (data mining)
- Finished product manufacturing
- Commercial packaging
- Adverse event data management
- Validation services
- Auditing services
- CMC preparation and global registration
- Marketing, sales, and distribution

## **C. Future Activities That May Be Outsourced**

- Screening of candidate molecules
- Modeling of preclinical studies
- Modeling of clinical trials and similar activities

## **II. OUTSOURCING ORGANIZATION IDENTIFICATION AND SELECTION**

### **A. Internal Resource Evaluation and Defining the Scope**

It is imperative that a thorough evaluation of the internal capability of an organization is performed before any decision to outsource is made. Once the decision is made, a clear definition of the project scope is listed on a form. At a minimum, the form should identify the following items:

1. Product information. Name, dosage form (tablet or liquid, vial, etc.), process, active ingredients, material safety data sheets (MSDS), analytical methods, cleaning validation/verification methods, special handling requirements, etc.

2. Outsourcing service needs. The specific stage at which the outsourcing service is needed (e.g., proof of concept, formulation development, phase I, II, or III stage or commercial manufacturing).
3. Relevant information, such as market forecast for a commercial product, bulk, or final packaged product, with or without complete analytical service requirements.

## B. Selection Resources

Once the specifics about the product are known the next step is the selection of an outsource organization. There are various resources in the industry from which one can obtain the information. Some of the resources are as follows:

1. Internet sources
  - a. [www.pharmtech.com](http://www.pharmtech.com)
  - b. [www.pharmsource.com](http://www.pharmsource.com)
  - c. [www.pharmaportal.com](http://www.pharmaportal.com)
  - d. [www.pharmaceuticalonline.com](http://www.pharmaceuticalonline.com)
  - e. [www.pharmpro.com](http://www.pharmpro.com)
  - f. [www.pharmaquality.com](http://www.pharmaquality.com)
2. Published directories
  - a. PharmSource Information Services
  - b. Technomark
  - c. Magazines and journals (*Contract Pharma*, *Pharmaceutical Technology*, *Bio Pharm*, *Formulation and Quality*, *European Pharmaceutical Contractor*, *Pharmaceutical Processing*, *American Pharmaceutical Outsourcing*)
3. Professional societies. Websites of
  - a. Parenteral Drug Association (PDA)
  - b. American Association of Pharmaceutical Scientists (AAPS)
  - c. International Society of Pharmaceutical Engineering (ISPE)
  - d. Pharmaceutical Outsource Manufacturing Association (POMA)
4. Industry associates and colleagues. Recommendations from industry colleagues are the best resources one can have.
5. Trade shows. Trade shows are an excellent place to collect information on contract manufacturing companies. You get to meet the people and discuss issues related to your project face to face. This is far more valuable than looking at fancy brochures.
6. Consultants and consulting firms.

## C. Preliminary Screening

Once the short list of potential outsource organizations is identified, a phone call requesting the specific information about the capabilities of the organization

should be made. The quality of the brochures should not decide which organization to select. A confidentiality agreement is initialed and signed at this time between the two parties. There is no substitute for visiting the site at which you intend to carry out your work. The first visit should not be an audit, but more of an exploratory visit. This visit should reveal if the organization has the equipment, personnel, and proper CGMP environment. This should set the stage for the due diligence process, including a quality audit of the organization. In some cases this quality audit is specific to the project at hand. A number of organizations prequalify the outsource organizations in anticipation of future needs.

## 1. Detailed Questionnaire

From the short list prepared above, a detailed questionnaire or a request for proposal (RFP) is prepared and sent to the companies for further evaluation.

The response to this RFP is evaluated. This can help narrow down the candidate list even further before investing the time and expense that both parties will incur during an audit or plant visit.

## 2. Due Diligence

The selection process focuses on various aspects of the outsource organization.

*Quality Audit.* Quality audit is only one aspect of the due diligence process; overall quality is the primary qualifier. Suppliers must be able to deliver quality products. They can demonstrate quality through ISO certification, CGMP compliance, and FDA inspection history, as well as their commitment to quality systems and vendor certification processes.

A quality audit should review following items:

1. Management and the history of the company
2. Capacities available
3. Capabilities—solid dosage, sterile products, liquids/semisolids, potent compound, different licensure (DEA, etc.)
4. Organization and personnel and their qualifications
5. What types of products are currently manufactured
6. Physical facility—layout, condition of the walls, floors, equipment, locker rooms, restrooms, cafeteria, etc.
7. Safety and industrial hygiene records and controls
8. Equipment—proper design and sizes for the project, use and cleaning records, documentation to show proper installation and operational qualification (equipment qualification; EQ), and in some cases performance qualification documents, validated computer systems, preventive maintenance program, records of equipment repairs and upgrades and subsequent requalification documentation, etc.

9. Procedures for purchasing, receiving, quarantining, sampling, storing, analyzing, and shipping are being followed
10. Manufacturing controls—sample batch records, list of SOPs packaging component control, raw material control, packaging and labeling control, yield accountability and reconciliation, warehousing and distribution
11. Laboratory controls—laboratory layout, staffing, instruments, procedures for handing out specification results, electronic records compliance, installation and operational qualification records (EQ, etc.)
12. Quality assurance—organizational independence, staff qualifications, self-inspection program, AQL, change control procedures, documentation and reports, complaint files, awareness of current regulations, statistical concept employed, batch record turnaround time, etc.

#### **D. Technical Support Capability**

The outsourcing organization receives the technology from the sponsor to manufacture the product. Any time such technology-transfer takes place at any given stage of the life cycle of the product, it is critical that the outsource organization has adequate resources to transfer the product from the parent organization. This includes the process know-how, analytical methods transfer, and so on. It is also imperative that the routine production problems can be solved by the outsource organization without requiring the sponsor organization's representative to fly to the plant or have a person stationed in the plant to solve the minor technical issues.

#### **E. Business Considerations**

An outsourcing relationship for commercial manufacturing requires that when a sponsor decides to bring the product to an outsource organization, a long-term relationship is anticipated. The fate of the product is literally in the hands of the outsource organization. Once the outsource plant site is registered with the FDA in an NDA or ANDA, it is very difficult, disruptive, and costly to relocate the product. Because of this, both parties should anticipate a long-term business relationship. The financial strength of a contract manufacturer is crucial. A review of the company's annual report will reveal the financial strength of the company. If the company is not publicly traded but is owned by a parent company, then the parent's financial strength should be reviewed. If the parent company is also not publicly traded a report on the company from a financial institution such as Dunn and Bradstreet (D&B) can be obtained. Other sources of financial viability are the company's bank and business references. If the project is short-term, in which phase I, II, or III supplies need manufacturing, the evalu-

ation can be less critical. Typically these are not long-term activities. The long-term manufacturing or supply agreement should be discussed at an early stage of the relationship between the parties. There may be philosophical differences between the upper management of both companies on crafting the agreement, hence it is necessary to reach an understanding on this subject at an early stage. A long-term commercial contract requires an in-depth understanding of the contract manufacturing company's business philosophy and the sponsor organization's current needs and the future plans. There are a number of companies that require contracts that are structured as "take or pay" types. This then requires both parties to commit to each other. The sponsor is required to guarantee the yearly quantity of product that he will have to purchase, and the outsource organization is required to reserve the capacity for that production. The discussion about intellectual property (IP) ownership should also come up during this early stage.

The contract normally spells out who owns what as far as IP goes, but at times it is possible that a new method or a new analytical technique may be developed by the contract manufacturing organization, and its ownership should then be clearly understood in the preliminary contract talks. The legal contract takes longer than either party anticipates, so it is prudent that once the decision to go with a specific outsource organization is taken the lawyers start discussing the supply agreement. Input from the business group of both parties is required during this stage. The pricing structure for the work and deliverables should be clearly understood between the parties well before this stage.

### **III. VALIDATION AND CONTRACT MANUFACTURING**

The relationship between the contract manufacturing company and the sponsor company is in some ways no different from that between the development/technology transfer departments and the manufacturing department in a pharmaceutical company. With the contract manufacturer as an outside entity, validation becomes a critical issue and needs to be viewed differently. The due diligence at the beginning of the relationship and the constant interaction between the sponsor and the contract manufacturing organization during the technology transfer stage offer the sponsor company a better understanding of the outsource organization's CGMP commitment. The validation issues become much more front and center during a quality audit and the subsequent interactions. The validation issues in contract manufacturing are the same as at any pharmaceutical company, except for the understanding of responsibilities between the parties.

Validation in the pharmaceutical industry was the result of the septicemia outbreak traced back to large-volume parenteral (LVP) manufacturing practices

prior to the 1970s. At that time the industry relied on final product testing to assure quality. The death of a patient was attributed to contaminated intravenous solution. We know now that quality cannot be tested into the product; it has to be built into the system. The purpose of validation is to provide documented evidence that the manufacturing process or method will yield the same product with the same ingredients and the same strength, as well as uniformity, thereby eliciting the same result each and every time it is used. This is accomplished through scientific testing and study, which is recorded and reviewed by responsible personnel. The “validation protocol” is a legally binding document that could be admissible evidence in a court of law. The document is approved and signed and becomes part of the official record as proof of a validated state of operation.

### **A. Commissioning and Validation**

The contract manufacturer’s responsibility is thus to be able to carry out these validation protocols for the facility, equipment, and systems. With a new plant start-up or an installation of new equipment there is sometimes a confusion about the terms commissioning and validation. The commissioning efforts are valuable where the extent of paperwork could be less than following the validation protocol. Some companies use “commissioning” for “noncritical” and “non-product contact” systems to minimize the extensive paperwork required. Commissioning involves the proper documentation of facility construction and installation. Every activity performed by a contractor must be documented as having been performed correctly. The validation process is designed to expose nonconformance to design and deficiencies in plant design, construction, and operation. With a validation exercise, a “facility qualification” is carried out. While evaluating any contract manufacturer’s facility, equipment, and system validation, one must make sure the interpretation of the commissioning and validation terminology matches the sponsor company’s understanding. The commissioning document should be available and structured to be equivalent to validation documents and should be subject to the same requirements, inspection, and functions as the validation document. In conjunction with the validation protocol, commissioning becomes powerful evidence that the contract manufacturer is in compliance with the CGMPs. For a contract manufacturer with an old facility and equipment dating from before the validation concepts as we know them now it is possible that a number of the original commissioning documents may not be available. Attempts have been made by these companies to perform “retrospective validation,” however. These documents may not meet today’s standards for EQ and should be evaluated with that understanding.

## B. Validation Responsibilities

Working with the contract manufacturer, the validation responsibilities must be clearly delineated. A clear understanding of these responsibilities will minimize the confusion, save precious time, and help assure that the preapproval inspection will be successful.

### 1. Define Responsibilities

Responsibilities toward the validation should be clearly defined and understood by the sponsor and the contract manufacturer. The responsibilities should be divided as follows:

Responsibility for	Contract manufacturing organization	Sponsor
Validation master plan	✓	
Facility commissioning and validation protocols, including all changes, repairs, etc.	✓	
Equipment and system commissioning and validation protocols including changes, repairs, etc.	✓	
Process validation and qualification of the product		✓
Ongoing compliance to validation documents	✓	✓

As can be seen from the table above, clearly defined responsibilities and expectations will eliminate confusion in a contract manufacturing relationship, along with any regulatory compliance concerns. As can be seen, the validation is the assimilation of the knowledge, which if managed appropriately, can be used to improve the performance of the contract manufacturing organization. The key regarding the validation is to be able to establish an ongoing quality manual between the two parties that will keep the sponsor organization aware of any changes that may affect the validation documents in the contract manufacturing facility.

## IV. PROCESS VALIDATION AND CONTRACT MANUFACTURING

The responsibility of process validation must reside with the sponsor in cases in which the sponsor has contracted with the contract manufacturer to manufacture

product with a supposedly “robust” process. If the process is not properly developed by the sponsor, the process validation efforts for the first three batches may or may not survive the “protocol” requirements. If the process is not optimized and somehow it survives the first three validation batches, the lack of robustness will show up during routine manufacturing. From a regulatory standpoint as well as from an economic standpoint, it is imperative that the process is well understood by both parties. The understanding gained of the manufacturing process means that initial start-up efficiencies will be higher. The generation of information from the validation allows the contract manufacturer to build into the manufacturing documents necessary conditions, ranges, and constraints to prevent the limits of failure from being approached. This activity manifests itself as a reduction in the rejection of batches. There are a number of instances in the industry in which the process was brought to a contract manufacturer that was less than robust. The validation batches were manufactured with a clear understanding that more process optimization work was needed. If there is immense economic pressure on the sponsor to file for approval, however, it could encourage ignoring the optimization of the process. On the other hand, the contract manufacturer does not have enough knowledge about the product if the product was not developed by his organization. Once the approval of the product is received and the process flaws remain, the contract manufacturer is left with writing the unacceptable number of process deviations. This could then result in challenges to the initial validation batch parameters by the authorities and create strained relationships between the contract manufacturer and the sponsor. This scenario is more prevalent if an already developed process is brought to the contract manufacturer by a sponsor company. If, on the other hand, the product is developed on a turnkey basis at the contract manufacturing location (i.e., from formulation development to phase III and commercial manufacturing), the process validation responsibility could rest with the contract manufacturer. Most of the virtual companies would rely on the contract manufacturer for all their validation issues. Process validation is critical in providing the required adherence to the regulatory compliance. It also provides real business advantages. The overriding benefits are in the efficiency and effectiveness of the process.

## **V. SUMMARY**

Validation of pharmaceutical facilities and processes has evolved into a regulatory requirement and an aid to the business as the risk management tool. Worldwide, pharmaceutical companies are struggling with the competing priorities of lowering costs, rising customer expectations, dwindling pipeline for the new blockbusters, ever-increasing regulatory burden, reducing the cycle times, and



minimizing the time to market. The need for contracting with an outside organization has become necessary business strategy for the pharmaceutical industry. Contracting with an outsource organization requires different types of assessments by the sponsor company, however. Starting with selecting a partner, evaluating the technical capabilities and financial strength is just the beginning. The ongoing relationship between the two depends upon the successful optimization of the process being transferred.

After the initial evaluation of the contract manufacturer, the successful process validation will enable both parties to achieve the economic benefits desired.

# 23

## Terminology of Nonaseptic Process Validation

**Kenneth G. Chapman**

*Drumbeat Dimensions, Inc., Mystic, Connecticut, U.S.A.*

### I. INTRODUCTION

The pharmaceutical industry's understanding of how to validate nonaseptic manufacturing processes for drug products and for drug substances matured considerably between 1983 and 1987. The steepest part of the learning curve occurred during the time in which everyone involved was learning to speak the same validation language. Basic concepts came into focus when terminology describing those concepts crystallized and was assigned unambiguous definitions. Most controversies surrounding the basic concepts had dissolved by 1988. The few that lingered beyond that time, however, are worth addressing because they may help explain why compliance failures by some firms with regard to process validation continue to be of concern to FDA.

A good way to get started is by defining a few terms. The term *validation*, (i.e., *establishing documented evidence that a system does what it purports to do*) attained its popularity after 1976 as a direct result of new current good manufacturing practice (CGMP) regulations [1]. Since these regulations emphasize the need for documentation, it is understandable that documentation became integrally associated with all forms of validation.

The terms *quality assurance* and *validation* are often used interchangeably—for good reason. Quality assurance is validation of the *quality function*. Dr. Juran defines such key terms these as follows [2]:

*Quality function* is the entire collection of activities from which we achieve fitness for use, no matter where these activities are performed.

*Quality control* is the regulatory process through which we measure actual

quality performance, compare it with standards, and act on the difference.

*Quality assurance* is the activity of providing to all concerned the evidence needed to establish confidence that the quality function is being performed adequately.

A quality assurance system usually involves a matrix of written procedures. Good manufacturing practices (GMPs) are thus frequently equated with quality assurance systems. By similar lines of reasoning, validation, quality assurance, and GMPs are often associated with each other and even occasionally treated synonymously.

*Process validation* means establishing documented evidence that provides a high degree of assurance that a specific process will consistently produce a product meeting its predetermined specifications and quality characteristics.

Validation of a sterilization process differs from validation of a nonaseptic process in several significant ways. A *sterilization process* is a treatment process from which the probability of any micro-organism survival is less than  $10^{-6}$ , or one in a million. *Sterility* means the absence of all life. *Aseptic* means the absence of pathogenic organisms. The difference between nonaseptic and aseptic process validation is that the aseptic process includes at least one measure that is intended to remove pathogens.

Validation of a sterilization process is always performed prospectively, and is essentially independent of in-process testing. Validation of nonaseptic processes is usually performed prospectively, but under certain circumstances can also be performed concurrently and/or retrospectively with adequate in-process testing and batchwise control. *Batchwise control* means the use of validated in-process sampling and testing methods in such a way that the results establish evidence that the process has done what it purports to do for a specific batch concerned, assuming control parameters have been appropriately respected. *Control parameters* are those operating variables that can be assigned values to be used as control levels. *Operating variables* are all factors, including control parameters, that may potentially affect process state of control and/or fitness for use of the end product. *State-of-control* is a condition in which all operating variables that can affect performance remain within such ranges that the system or process performs consistently and as intended.

Sterilization validation involves establishing that a system sterilizes, whether or not testing is performed on the end product. The need for such evidence stems from the fact that sterility is not an absolute product attribute that can be determined by end-product testing alone.

Validation of a nonaseptic system is also occasionally referred to as process validation or solid dosage validation. While both terms are descriptive,

neither is comprehensive. Validation of a new nonaseptic process is synonymous with but not identical to the term process development. The key difference is that process development includes optimization of control parameters while validation does not.

*Process development* means establishing evidence that all process control parameters and all control parameter ranges are validated and optimized. *Control parameter range* is a range of values for a given control parameter that lies between its two outer limits, or control levels.

While there was nothing new in the early 1980s about the need for process development to prove meaningfulness of its control parameter ranges, it is obvious that FDA's emphasis on validation brought with it an increased tendency by industry to document such proof.

Two terms initially misunderstood by many regulators and practitioners were

Edge of failure

Worst case

*Edge of failure* is a control parameter value that, if exceeded, means adverse effect on state of control of the process and/or fitness for use of the product. Although it can be useful to know where the edges of failure occur, it is not essential [3].

Worst case underwent several controversial definitions before debates in meetings and in publications finally resolved the issue. At one point, several regulators asserted that worst case and edge of failure were equivalent and both were essential to process validation. As seen later, [Figure 2](#) puts the issue in perspective and underscores the importance of “pyramiding” operating ranges, control ranges, and regulatory ranges. An accepted definition of worst case today is *the highest or lowest value of a given control parameter actually evaluated in a validation exercise*.

Another useful concept is the *proven acceptable range* (PAR) [4], which includes all values of a given control parameter that fall between established high and low worst-case conditions.

Process validation fundamentals are the same for processes that produce drug substances (active pharmaceutical ingredients) and those that produce drug products.

## II. LIFE CYCLE AND TIME LINE

[Table 1](#) lists 12 steps in the process validation life cycle for a new process, starting with definitions of the product and the process [5]. Each step needs to be documented, using approved validation plans and/or protocols.

**Table 1** Twelve Key Steps in the Validation Life Cycle of a New Process

1. Define each module (step, unit operation) of the process.
2. Define *critical product specifications*.<sup>a</sup>
3. Define the *critical process operating parameters*.<sup>a</sup>
4. Develop the *critical process operating parameter ranges*<sup>a</sup> based initially on laboratory studies of manufacturing material behavior under normal and stress conditions, and later on results of producing products under varied conditions.
5. Define the *probable adverse consequences*<sup>a</sup> of exceeding the critical process operating parameter ranges in each direction (end values).
6. Implement comprehensive *change control*<sup>a</sup> and *revalidation*<sup>a</sup> procedures.
7. Qualify equipment (*installation qualification*<sup>a</sup> and *operational qualification*<sup>a</sup>).
8. Train and qualify operational and supervisory laboratory and plant personnel in product-specific validation principles.
9. Ensure that interrelated systems (e.g., LIMS, environmental controls, utilities) are all validated.
10. Conduct *performance qualification*.<sup>a</sup>
11. Assemble and document evidence of *process robustness*<sup>a</sup> and reproducibility.
12. Provide for retention of archived validation files for required periods following last commercial lot expiration date.

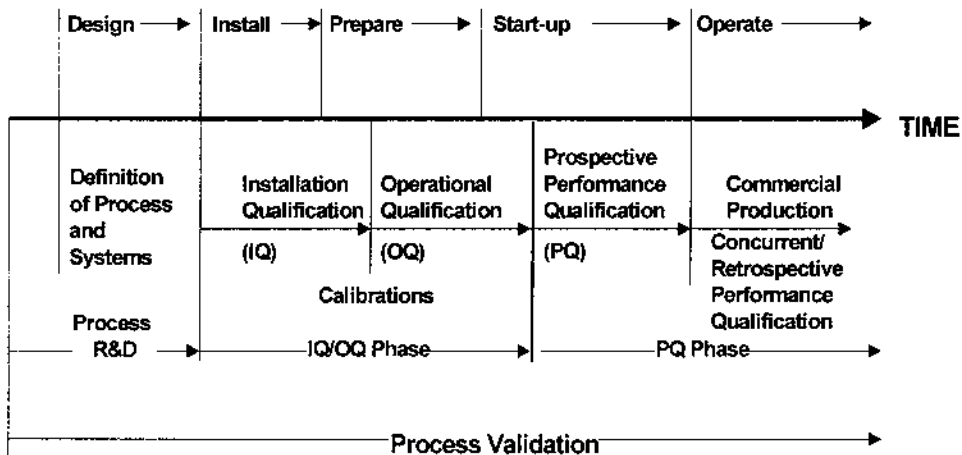
<sup>a</sup>Italicized terms are defined in this chapter.

Figure 1 provides a validation time line that embraces this life cycle. Critical product specifications are determined chiefly by safety and efficacy (animal and human) studies. Critical process operating parameters are a function of process capability and are determined by process development, which includes process validation. Experienced process validation practitioners and regulators have learned repeatedly that just as “quality must be built into a product” (i.e., “it cannot be tested in”) robustness also has to be built into a process. A *robust process* is a process that behaves in a stable manner even when minor changes occur to its critical process parameters.

Process validation embraces an entire life cycle beginning in R&D, including IQ, OQ, and PQ (installation, operational, and performance qualifications), and ending only when the related product is no longer commercial [6]. (An older, now outdated, perception is that process validation starts after IQ and OQ.)

### III. QUALIFICATION: IQ, OQ, AND PQ [7,8,13]

Widespread confusion accompanied a variety of definitions that originally appeared for the three qualification terms. A few fundamentals about each may be helpful.



**Figure 1** Process validation time line for a new process.

Systems and processes are validated, equipment and materials are qualified, and persons are trained and qualified.

IQ is intended to ensure that all critical equipment has been purchased and correctly installed.

OQ is intended to ensure that all critical equipment works as intended for the process in which it is to be used.

It is not unusual for some IQ and OQ activities to overlap, an occurrence that presents no problem as long as it is recognized and addressed systematically.

IQ and OQ data records must be adequate to support ongoing and future change control and revalidation requirements.

PQ is intended to demonstrate that the process will function correctly in its normal operating environment. The demonstration may involve pilot lots, commercial-scale lots, or carefully designed simulations of either. In the case of drug substances, PQ protocols often involve individual modules (e.g., steps, unit operations) of a new process prior to pilot or commercial scale-up of the full process. When a given critical process parameter cannot be simulated at less than commercial scale, all other process parameters are often established first, to avoid potential interference with the first commercial batch that must involve the sensitive parameter. The three full-size lots required to authorize commercial distribution can, if desired, represent key PQ experiments; however, there is no limit to the number of subsequent commercial lots that can also continue to be considered part of the PQ step in a validation life cycle.

Instrument calibration is an example of an activity that often overlaps IQ and OQ, as well as other steps in the life cycle. In validation work, instruments frequently need more extensive calibration (e.g., concerning linearity) than is required for subsequent process control applications. The step or steps in which the records are included is unimportant as long as the records are available and consistently documented. Some firms even find it convenient to treat calibration as a separate, overlapping qualification measure.

Performance qualification steps in a sterilization validation project usually require a prospective approach. The most common steps in prospective validation are the following:

1. Preparation and approval of a master plan and qualification protocols
2. Qualification of systems and subsystems
  - a. Installation qualification
  - b. Operational qualification
  - c. Performance qualification
3. Execution of all remaining protocols
4. Analysis of results in a task report
5. Approval of task report conclusions

Most firms today start by qualifying each subsystem. To qualify, of course, means to establish convincing evidence that something happens as intended, which matches the validation definition (in more explicit terms, however). *Installation qualification* may be defined as documented verification that all key aspects of the installation adhere to manufacturer's recommendations, appropriate codes, and approved design intentions. *Operational qualification* is documented verification that a system or subsystem performs as intended throughout all specified operating ranges.

Performance qualification became popular as a much-needed term in the late 1980s, prior to which it possessed several conflicting definitions. The primary need for the PQ term emerged as the result of a parallel semantics issue concerning the overall meaning of process validation itself. By the late 1980s, confusion existed as to whether process validation was something that followed the IQ and OQ steps or something that embraced an entire life cycle, beginning in R&D and ending when the new product was no longer commercial. Today, the life cycle version dominates, making it much easier for firms and regulators to recognize the importance of R&D roles and validation maintenance. Performance qualification became more universally accepted as the step that follows IQ and OQ and means documented evidence that all steps in the defined process actually function as intended and produce expected and predetermined results under normal operating conditions.

Once all IQ and OQ steps are completed, including calibrations, the PQ protocol can be executed. The *PQ protocol* is a prospective experimental plan

that, when executed, produces documented evidence that the total system works as intended. The PQ protocol includes an explicit definition of the total process to be validated, including operating variables and expected process control parameters, and specifications of the end product(s). It may also address the degree of replication considered appropriate to provide statistical significance.

In the course of executing any experimental protocol, results occasionally differ from expectations. When this occurs, it is useful to prepare and approve a protocol supplement rather than, for example, rewriting the protocol. Such practice provides a clear chronological record and avoids creating an impression that the experiment was designed after its execution. A *Protocol supplement* is a document that explains one or more changes to the original protocol, including rationale for making the revision.

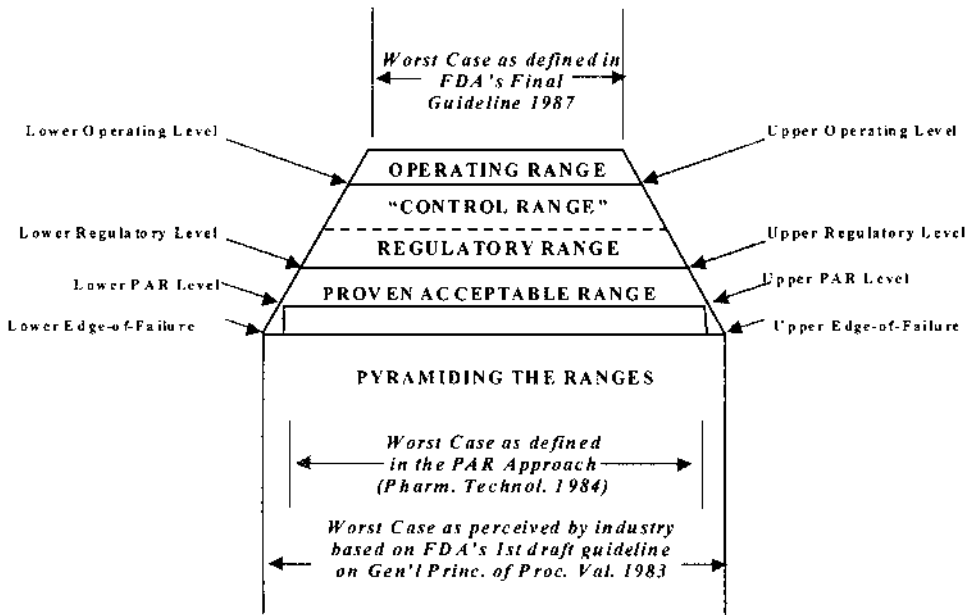
#### **IV. R&D ROLES, PROCESS ROBUSTNESS, AND THE PYRAMID**

Research-based pharmaceutical firms worldwide have become highly conscious of all factors that can affect time to market of their new products. Every day on the critical path toward regulatory approval is important, economically and competitively. Early development of a robust process, both for drug substance and for drug product, significantly enhances time to market of a new product [9,12,14,15].

Examination of [Figure 2](#), which illustrates pyramiding of parameter ranges, provides insight regarding the important relationships between process robustness and process validation.

It is important to understand the proven acceptable, regulatory, and operating ranges when writing performance qualification protocols. Many firms also use control ranges that lie between operating and regulatory ranges for added insurance against—and control over—minor plant deviations. Regulatory range limits represent those limits that a firm includes in its registration, such as a new drug application (NDA). The firm's basic commitment is that product safety and efficacy will be ensured when all regulatory limits are met. Regulatory range limits must fall within the upper and lower edges of failure. In order to define edges of failure, it is essential to identify what the probable adverse consequences are of exceeding the edges of failure in each direction. For example, exceeding the upper edge of failure for tablet hardness might cause an unacceptable dissolution rate, while exceeding the lower edge of failure could lead to friability problems. Overheating an API (drug substance, or active pharmaceutical ingredient) solution may cause predictable degradation reactions, while underheating might cause premature crystallization or failure to complete a desired reaction [16].





**Figure 2** Parameter ranges.

Many firms employ more than one range of internal limits, such as control ranges for quality monitoring and approvals, as well as the usual and somewhat tighter operating ranges for shop-floor directions. As seen in Figure 2, each internal range must lie within the corresponding regulatory range for compliance. Control ranges are often found to be convenient, especially for in-process control test limits, but need not be regarded as essential.

In its initial 1983 draft guideline, FDA proposed that process validation should be based on FDA's definition of "worst case," which at that time extended from one edge of failure value to the other (Fig. 2). The industry objected to the proposal, and pointed out in a 1984 article [4] that it is unnecessary to have either edge of failure value available, as long as one can establish a PAR that embraces the regulatory range. In its final 1987 guideline [7], FDA redefined worst case (Fig. 2) to equate with the operating range, a move that facilitated future process validation planning.

As illustrated in Figure 2, a validation effort that establishes the PAR ensures not only that regulatory commitments will be met, but also that all internal control and operating ranges are validated as well.

Although not absolutely essential, it can be worthwhile to identify edges of failure, since the difference between edge-of-failure ranges and regulatory ranges help determine the sensitivity of the process to cause product rejections. Edge-of-failure data, as well as all other limit values, can frequently be determined in the laboratory or pilot plant (e.g., using aliquot samples from the pilot plant) long before the process is fully scaled up.

For APIs (drug substances), reaction kinetics are often used to predict thermal and pH end values. Other studies that help ensure robustness can be created in the early stages of API process development. For example

1. Determination of conditions under which API polymorphs, isomers, hydrates, solvates, and degradation products might form (also important for process patent reasons)
2. Isotherms of pH and temperature versus API solubilities, degradation rates, and other variables
3. Similar studies involving major impurities specific to the API process

In the case of drug products, developmental pharmaceuticals (which include physicochemical profiles and excipient interaction studies) provide similar information that is needed to determine edges of failure and reliable end values. Stability studies and behavior of various lots of clinical supplies also contribute insight to drug product end value design.

Final confirmation of operating ranges for some unit operations, such as blending, will require exploratory studies in larger equipment. In the case of blending, such studies should be preceded by particle size measurements and crystal morphology studies in the laboratory, since tendency to blend or deblend is often predictable. Blending also represents a case in which commercial-scale experiments can usually be run at low risk; for example, to optimize rotational speed and time periods by testing aliquot samples taken at various time intervals.

## **A. Use of Statistics in Process Validation**

Some current publications address process validation from an almost exclusively statistical approach. The effect of such articles on nonstatisticians usually ranges from dismay to panic and, unfortunately drives them away, instead of toward use of statistics. Statistical process control (SPC) can be especially valuable when applied to process validation, both before and after the validated process enters commercial use. By statistically analyzing critical process parameter data throughout a batch or continuous process, SPC provides the opportunity to predict problems (trend analysis) and even take corrective action (trend control), before the problems occur, yet relatively few firms appear to be actually implementing SPC universally across all processing today, probably because SPC

appears complicated to many individuals and in many cases is not truly essential.

Statistical analysis is routine and taken for granted in most laboratory work, including the validation and implementation of analytical test methodology and in the design of most sampling plans. A question that frequently arises is when statistical tools need to be applied to determine the adequacy of operating and regulatory ranges (i.e., process capability). A glance at [Figure 2](#) might help answer this question. If a PAR exists for a given parameter that is 20% wider than the regulatory range, and if the regulatory range is 20% wider than the operating range, the process is likely to be robust enough to obviate the need for statistical analysis for the given parameter. Conversely, if the same ranges appear to be within 2% of each other, the process may or may not require more development, but statistical analyses should certainly be considered. Between those two extremes, judgment is needed of the kind that can often be provided only by statistical experts.

Another common situation in which statistical analyses may be essential occurs when multiple critical process operating parameters display interactive effects and none of the parameters can be analyzed in isolation. Factorial design experiments may be required, the design and interpretation of which often demand statistical analyses.

The bottom line is that most process validation teams should include or have access to a statistics expert. Because SPC offers many opportunities to improve costs and quality through trend analyses and control, SPC is recommended as a measure to be considered in any process validation program.

Once validation execution is complete, the data are analyzed and a task report is written. Worst-case conditions actually validated may have different values from those predicted. Such observations do not mean the work needs to be repeated, but simply that the PAR should be appropriately recognized.

Many firms find a task report conclusion form useful for formal approval. This obviates the need for formally approving the entire task report. A *validation (or qualification) task report* is a scientific report of the results derived from executing a validation or qualification protocol. *Validation task report conclusions* are a brief summary of conclusions from a specific task report, usually indicating validation success and identifying acceptable mean ranges that have resulted. Such conclusions are formally approved.

An efficient document management and control system is essential for minimizing the costs of a process validation effort. Detailed discussion of document management is beyond the scope of this chapter; however, one suggestion is offered that has proven particularly successful. Efficiency of the document review and approval process can be greatly enhanced by a policy that defines the purpose of each signature required (e.g., technical correctness, regulatory compliance, compliance with other corporate documents, and authority to pro-

ceed). Such a measure helps minimize the number of signatures required by informing all parties involved of their expected roles.

## V. THE THREE-LOT CONTROVERSY

During 1983 and 1984, representatives of FDA and industry debated at length over the value of positioning three consecutive commercial-sized lots as pivotal evidence of process validation. Industry agreed that FDA's argument for three lots might be suitable for medical devices, but argued successfully that it was not appropriate for pharmaceutical processes, for several reasons.

1. It was unnecessarily costly and risky to perform prior to regulatory submission.
2. There was limited statistical benefit from three lots.
3. Establishing critical process parameter ranges and probable adverse consequences of exceeding range limits represents a better investment of resources and contributes more to process robustness and reliability.

In 1990, when FDA launched its preapproval inspections (PAI) program, the three-lot issue again arose. The PAI's chief architects (Richard Davis and Joseph Phillips, FDA Newark district directors) announced they would require evidence of three consecutive successful lots of commercial size prior to shipment of a new product across state lines as "final" evidence of process validation, even when the firm had already received its NDA approvable letter.

This time, the industry did *not* protest the requirement. Several reasons made the requirement logical, including the following:

Three commercial lots add some degree of assurance that the process works, and offers at least a limited indication of reproducibility.

Three lots can usually be made in a practical period of time, compared with the number of lots that would be required to gather statistical evidence of reproducibility.

The overall approach forces focus of validation emphasis on process development measures that occur earlier in the life cycle, and thus enhance rather than jeopardize time-to-market goals.

Since 1990, most firms have found the predistribution three-lot requirement practical and useful. Some have made the mistake of believing that critical parameters should be varied during the three runs in order to develop new validation evidence, usually of the kind that can be developed in the laboratory or pilot plant more economically and with less risk of failure.

## VI. PROSPECTIVE, CONCURRENT, AND RETROSPECTIVE APPROACHES

In the early 1980s some regulators treated consideration of retrospective or concurrent validation as almost sacrilegious, asserting that everything must be done prospectively. The issue became controversial. Fortunately, speakers on both sides of the controversy listened to each other, and by the twenty-first century, agreement on the subject had been achieved.

*Prospective validation* is establishing documented evidence that a system does what it purports to do based on a preplanned protocol.

*Concurrent process validation* is establishing documented evidence that a process does what it purports to do based on information generated during actual implementation of the process.

Retrospective process validation was doubly controversial in the early 1980s because FDA and the industry even disagreed on the meaning of the term. The FDA's definition indicated that retrospective meant performing the validation after the product was already in the marketplace, a practice that nobody would endorse, and would more fittingly be referred to as retroactive. Industry argued (with ultimate success) that a more useful definition of *retrospective process validation* is establishing documented evidence that a system does what it purports to do based on review and analysis of historic information. The term historic could mean the information was an hour old or years old.

For better understanding of the issues, the following three cases in which retrospective and/or concurrent approaches make sense are discussed:

1. Established commercial processes for which original development data that support control parameter ranges are no longer available or deemed sufficient
2. New processes, usually in an R&D setting for which limited history exists, such as early clinical supplies
3. Certain unit operations, performance qualification of which can only be confirmed at full commercial scale (e.g., blending, discussed below).

In the first case, as discussed in Sec. VII below, a retrospective review of multiple batch records can provide considerable insight to support a defined PAR. A similar approach might involve a spreadsheet that summarizes critical parameter values for a series of R&D lots when preparing to transfer the technology to R&D's production colleagues. Often such retrospective data can be reinforced where gaps occur by some prospective laboratory or pilot plant experiments.

In the second case—development of processes for producing formulations of new drug entities—prospective, concurrent, and retrospective validation approaches are all useful. Initial lots, usually involving small quantities, are each tested in a far more extensive manner than would be appropriate or economically feasible for a commercial process. Each lot is proven to be exactly what was intended. It is not unusual, for example, for every capsule prepared in a small lot to be individually weighed when the ensuing clinical experiment is of sufficient importance. As the new product and its processes are developed, the history of such lots accumulates. Prior to preparing some lots, experimental protocols are designed to obtain certain development (or validation) data prospectively. The history of all lots is reviewed retrospectively, however, to learn more about control parameters and where acceptable mean ranges lie, thus as the new process approaches commercial status, its validation also approaches completion from both prospective and retrospective efforts.

The third case can be illustrated by discussing the unit operation known as blending, which occurs in both drug product and drug substance processes. Blending can be a complicated process involving critical parameters other than such obvious examples as blender capacity, rotational speed, and blending time. For each component, it might be necessary to consider and control particle size, crystal morphology, specific volume, angle of repose, hygroscopicity, residual solvent, residual moisture, and even electrostatic charge. The tendency of some blends to deblend can often be associated and even cured by determining correlations with both particle size and the specific volume of the components. Despite the predictive value of studying the components, it is usually prudent to complete the PQ of an expensive pharmaceutical blending step cautiously and at full scale. If any likelihood of deblending is suspected, assaying a series of timed aliquot samples over a time span greater than intended for the ultimate blending step can provide further assurance. Finally, a firm has the option of checking every batch of a blend for uniformity by assay, using validated sampling and testing procedures until sufficient evidence has accumulated to declare the PQ successful and complete.

As in the above blending illustration, there are numerous opportunities to combine prospective, concurrent, and retrospective qualification measures in most validation programs.

## **VII. CHANGE CONTROL AND REVALIDATION**

Once a system has been validated, it is considered to be in a state of control. As long as all conditions and control parameters remain unchanged, the system continues in its validated state. It is important for any significant change be recognized before or at the time it occurs, whether the change is to the process,

equipment, or other related systems that can affect the process, so that appropriate action can be taken promptly to preserve validation status.

Most firms today use a validation change control system, by which such documents as engineering work orders, revisions to standard operating procedures (SOPs), and proposed formulation order changes are reviewed by a committee of the same disciplines as those responsible for validation approvals. The objectives are to determine the potential impact on validation status before formally approving the change. This mechanism enables a firm to take immediate prospective action, obviating the need to revalidate the entire system.

With the industry's trend toward automation, including the increasing use of electronic signatures and records, many processes that have been manually controlled for years are becoming increasingly fully automated. Equipment-cleaning validation has also become a regulatory requirement, occasionally leading to the need for process modification. Many pre-existing processes are thus becoming part of larger systems, validation of which entails more than just process validation. Also, some processes will be relocated to a new plant or to the plant of a contract vendor, necessitating some level of revalidation.

The validation life cycle for a relocated or altered process (revalidation) resembles that required for a new process except for those completed qualification measures that can be shown to be independent of the change. Where existing equipment is used, much of the original IQ and OQ work will still apply. Processes that have been run for years (legacy) will have created many batch records that, with appropriate retrospective statistical review, can offer revalidation data relevant to the modified process or system, provided that the original process is well defined and adequate change control measures have been in effect. Revalidation thus does not necessarily involve repeating all of the original validation work.

*Revalidation* means repeating the original validation effort or any part of it, and includes investigative review of existing performance data. It is good practice to review all such decisions at least annually to determine if collectively they add up to a need for further study or validation work. It is efficient to make this annual revalidation review part of the required annual records review effort, in which case existing data, such as those from manufacturing batch records, in-process control testing, and stability testing are reviewed and analyzed to reconfirm formally that control parameter ranges are appropriate (i.e., validated). A review of process waivers (or process change notifications), quality assurance investigation results, and even product or in-process rejection data can also be helpful here in revealing worst-case conditions and sometimes where edges of failure occur. Validation protocols are not generally needed for such retrospective validation, but formal approval of final results is often deemed appropriate. The same database mentioned above, as derived from numerous commercial batches run by a given process, can also be used to generate trend

analysis profiles. Such analysis represents a long-standing quality assurance technique for predicting when processes, although still within their validated control ranges, may be heading toward trouble.

It is important to recognize that the validation life cycle and validation change control continue as long as the related product remains in the marketplace. *Validation change control* is a formal monitoring system by which qualified representatives of appropriate disciplines review proposed or actual changes that might affect validated status and cause corrective action to be taken that will assure that the system retains its validated state of control.

Many long-established practices that deal with change control are already covered by quality assurance programs and by the CGMPs. For example, requirements for receiving, inspecting, sampling, testing, and storing raw materials, packaging materials, and labeling, as well as for approving new suppliers, all require formalized systems that include substantial documentation. Unless such systems fall below normally accepted standards, it should not be necessary to modify or repeat them in order to maintain a new validation program in a suitable state of control.

Finally, it should be recognized that different manufacturing and consulting firms use the term *certification* in many different ways. Task report conclusions forms represent a type of certification. Some find it useful to issue certifications for IQ, OQ, calibration results, and various stages of validation.

Certification of revalidation can be useful; however, the manner in which formal approvals are documented is best left up to each individual firm, and use of formalized certifications should be considered entirely optional. *Certification* is documented testimony by qualified authorities that a system's qualification, calibration, validation, or revalidation has been performed properly and the results are acceptable.

## **VIII. MASTER PLANS AND PROJECT PLANS [10,11]**

The validation master plan (VMP) is a master document that begins with the initiation of any validation project and is regularly updated as needed, at least until the product becomes commercial. Although the VMP is specifically called for by most contemporary draft regulatory validation guidelines, it has become a confusing term because two basic definitions exist. Both are used by different (and sometimes even the same) regulatory officials. One definition calls for the VMP to be project-oriented; the other definition describes a more global document embracing a firm's overall validation philosophy.

Most pharmaceutical firms use policies and/or SOPs to address such global matters individually. Although the global VMP definition can be made to work, it is cumbersome and inefficient. To minimize confusion, a firm should



clearly define its use of the term VMP (e.g., by written policy), while ensuring that global and project-related matters are both adequately covered in some way. For firms preferring the global VMP, a term such as *validation project plan* might be used for the shorter version.

## IX. SUMMARY

Nonaseptic process validation has become a major factor in improving quality assurance of pharmaceutical processes since 1983, when FDA introduced its first draft guidance document on the subject. Understanding process validation, both by industry representatives and regulators, has matured during that time, as all parties involved have gradually arrived at agreement on the terminology and basic principles involved. With that understanding has also come recognition that the process validation life cycle necessarily begins at an early process development stage, usually in R&D, and continues until the products involved are no longer commercial.

Global importance of process validation has steadily expanded, commensurate with dramatic evolution of new automation technology, use of electronic signatures and records, and increased emphasis on the need for equipment-cleaning validation. Interrelationships of the several kinds of validation that are now involved are driving major firms to recognize the need for multidisciplinary validation teams in achieving efficient technology transfer. In particular, the firms are discovering how important R&D's roles in the process validation effort can be to enhancing their new product time to market.

The validation era brought with it the need for humans involved to communicate with new terminology. The purpose of this chapter has been to identify and explain the key terminology needed to understand nonaseptic process validation. A currently popular, lucid, and accurate definition of process validation itself is *well-organised, well-documented common sense*.

## REFERENCES

1. U.S. Food and Drug Administration. FDA's proposed revisions in drug GMP's. *Fed Reg* **41**(31): 6878–6894 (Feb. 13, 1976); reprinted in The gold sheet. **10**(2) (Feb. 1976) (FDA Reports, Inc.).
2. Juran, J. M. *Quality Control Handbook*. 3rd ed. New York: McGraw-Hill (1974).
3. Chapman, K. G. A Suggested validation lexicon. *Pharm Techn* **7**(8):51–57. (1983).
4. Chapman, K. G. The PAR approach to process validation. *Pharm Tech* **8**(12): 22–36 (1984).
5. PMA Validation Advisory Committee. Process validation concepts for drug products. *Pharm Tech* **9**(9):50–56 (1985).

6. PMA Deionized Water Committee. Validation and control concepts for water treatment systems. *Pharm Tech* **9**(11):50–56 (1985).
7. National Center for Drugs and Biologics and National Center for Devices and Radiological Health. *Guideline on General Principles of Process Validation*. Rockville, MD (May 15, 1987).
8. FDA CDER, CBER, CVM. Guidance for Industry—Manufacturing, Processing, or Holding Active Pharmaceutical Ingredients (March 1998).
9. European Agency for the Evaluation of Medicinal Products, CPMP, CVMP. Note for Guidance on Process Validation. Draft (Sept. 30, 1999).
10. Pharmaceutical Inspection Convention. *Recommendations on Validation Master Plan, Installation and Operational Qualification, Non-Sterile Process Validation, Cleaning Validation*. PR 1/99-1 (March 1, 1999).
11. European Commission. Validation Master Plan Design Qualification, Installation, and Operational Qualification, Non-Sterile Process Validation, Cleaning Validation. E-3 D(99) (Oct. 30, 1999).
12. PhARMA QC Section, Bulk Pharmaceuticals Committee. Concepts for the process validation of bulk pharmaceutical chemicals. *Pharm Tech Eur* **6**(1):37–42 (Jan. 1994).
13. U.S. Food and Drug Administration. Current Good Manufacturing Practice: Amendment of Certain Requirements for Finished Pharmaceuticals, –21 CFR Parts 210 and 211 pages 20103 to 20115. *Federal Regulation* (May 1997).
14. ABPI. Draft PIC GMP Guide for Active Pharmaceutical Ingredients. (Oct. 7, 1997).
15. U.S. Food and Drug Administration. Guidance for Industry; BACPAC I: Intermediates in Drug Substance Synthesis; Bulk Actives Post-approval Changes: Chemistry, Manufacturing, and Controls Documentation. Draft Guidance, whole document 1–24 (Nov. 17, 1998).
16. Institute of Validation Technology Standards Committee. Proposed validation standard VS-1-nonaseptic pharmaceutical processes. *J Val Tech* **6**(2) (Feb. 2000).

# 24

## Harmonization, GMPs, and Validation

**Alfred H. Wachter**

*Wachter Pharma Projects, Therwil, Switzerland*

### I. INTRODUCTION

The origin and early years of validation in the context of the U.S. FDA's GMPs are discussed in the chapter "[Regulatory Basis for Process Validation](#)" by J. M. Dietrick. The following summarizes the corresponding developments in other parts of the world and assesses the chances of arriving at consolidated global concepts of GMPs and validation.

### II. DEFINITION OF THE CONCEPT OF VALIDATION IN THE 1980s

#### A. U.S. FDA

The words *validate* and *validation* turned up in the 1978 revision of the *Good Manufacturing Practices* regulations as Parts 210 and 211 of Title 21 of the *Code of Federal Regulations* (CFR) [1], but at that time there was no obvious indication that these words were used in a sense other than was customary. There was no mention of *process validation*; only *analytical method validation* was discussed as an element of GMP. It was another guidance document, the proposed GMPs for large-volume parenterals [2], that gave it a more specific ring. Although this proposal was withdrawn some 10 years later, it had been around long enough to make the concept of validation sink in; in particular the special meaning familiar to anyone dealing with the manufacture of sterile products in the United States and abroad.

When the concept of validating processes was about to switch over to nonsterile processes, the soon-to-be-regulated pharmaceutical industry wanted to be at the table where the idea was being shaped.

International bodies such as FIP and EOQC were the first outside the United States to show interest in the process of defining the main contents of this new extension of GMPs for nonsteriles. Their idea was to bring in the experience of the practitioners at an early stage before the matter had solidified into a set of regulatory requirements with an overly theoretical and dogmatic content.

The early involvement of industry was useful in that it paved the way for the official documents to be issued by the regulators. The first of them was the well-known process validation guideline of the U.S. FDA [3] in 1987.

## **B. Fédération Internationale Pharmaceutique**

The FIP conference of 1980 chose validation as one of the main themes and agreed on a paper [4] that interpreted validation and the connected activities. The “Guidelines for Good Validation Practice” had been prepared by a working group composed of members from health authorities and industrial pharmacists. A synopsis of the main elements is shown in [Table 1](#). The accepted final paper was successful in avoiding a bureaucratic tone and defining validation in terms of elements that can be considered to be truly adding value.

## **C. EOQC**

In 1980, the *European Organization for Quality Control* (EOQC as it was called then, now only EOQ) devoted its seminar in Geneva to *validation of manufacturing processes*. The discussions were conducted by three working groups: *general considerations, administration, and control; equipment and support systems; and standard operations*. The results of these discussions were summarized in the following commonly accepted conclusions [5]:

1. The organizational approach in validation studies depends on the individual company.
2. Retrospective validation is acceptable for nonsterile products if sufficient and representative data support the case.
3. The cost increase should be offset by cost reduction for quality control and failure investigation and correction.
4. There should be a reasonable balance between validation and quality control.
5. The approach of regulatory guidance to define the *what* and the company to come up with the *how* was seen as sound.

**Table 1** Early Validation Concepts (Before 1990)

Source	Events, documents	Validation topics
FIP (1980)	Federation International Pharmaceutique, Commission of Official Control Laboratories and Industrial Pharmacists, Conference 1980: "Guidelines for Good Validation Practices" [4]	Definition, development phase, production phase, validation of existing processes, revalidation, responsibilities
EQQC (1980)	European Organization for Quality Control, 4th European Seminar (1980): <i>Validation of Manufacturing Processes</i> (Geneva) [5]	Definitions, installation and operational qualification, development and manufacturing phase, responsibilities and organization, use of historical data, change control and revalidation
APV (1981)	International Association for Pharmaceutical Technology: <i>Praxis der Validierung (Validation in Practice)</i> , Symposium (1981–1982, Gelsenkirchen) [6]	Terminology, sterile, semisolid, and solid dosage forms in development and production, analytical methods and stability evaluation, packaging development and packaging validation transfer, cost-effectiveness
U.S. FDA (1987)	<i>Guideline on General Principles of Process Validation</i> [3]	Process validation (see <a href="#">Table 5</a> )
PIC (1989)	<i>Guide to Good Manufacturing Practices of Pharmaceutical Products</i> , PIC-Doc PH 5/89 (now PH 1/97 (rev. 2) [7])	Validation of critical processes, significant amendments to manufacturing processes, significant amendments to manufacturing processes, and of all sterilization processes and test methods stipulated.

6. The cases studies presented should only be seen as useful examples and not as rigid positions to be followed in each case.
7. The need for validation for new products by challenging the process to identify critical variables was commonly accepted.
8. Revalidation was considered to have its merits; however, no agreement was reached with regard to the triggering mechanism.

It is noteworthy that the principles and concerns have not changed very much in the last 22 years. To my knowledge, this is also the first general treatise discussing qualification of process equipment and support systems.

## D. APV

Another professional organization headquartered in central Europe, APV (*International Association for Pharmaceutical Technology, Mainz, Germany*), developed the topic further in two seminars in Gelsenkirchen in late 1981 and early 1982 [6]. Speakers from industry demonstrated how validation could be applied to industrial activities and how a balance between resources allocation and results could be achieved. Oral dosage forms, topicals, and sterile products, as well as analytical methods during development, transfer, and production phases were discussed.

The following positions were supported by the attendees:

1. Validation is just one tool in quality management. Others include acceptance testing, in-process and final control, and the totality of the GMPs.
2. Validation should be tailored to the needs of the study objective and the company structure. The responsibility for extent, depth, and approach chosen lies with the company.
3. Validation means doing what is necessary to demonstrate that a process is mastered and avoiding excessive formal exercises by setting priorities based upon risk assessment.
4. Validation should not be done by ticking off generic checklists.
5. Validation should allow a trade-off in the type and frequency of checks to be done routinely.

## E. PIC

Contrary to the organizations mentioned so far, the *Pharmaceutical Inspection Convention* (PIC) was conceived by the health authorities of 10 member countries of the *European Free Trade Association* (EFTA) in 1970. The main goals of this legal treaty were to harmonize GMP requirements across the member countries and to recognize GMP inspections mutually. The PIC issued *Basic Standards for GMP for Pharmaceutical Products* in 1973. It was partly based on the WHO standard, partly on national guidelines. In its 1989 revision some basic requirements regarding validation (including definitions of *validation* and *qualification*) were spelled out.

*Qualification*: Action of proving that any equipment works correctly and actually leads to the expected results. The word *validation* is sometimes widened to incorporate the concept of qualification.

*Validation*: Action of proving, in accordance with the principles of *GMP*, that any procedure, process, equipment, material, activity, or system actually leads to the expected results.

The section on *validation* contains the following four paragraphs:

- 5.21 Validation studies should reinforce GMP and be conducted in accordance with defined procedures. Results and conclusion should be recorded.
- 5.22 When any new manufacturing formula or method of preparation is adopted, steps should be taken to demonstrate its suitability for routine processing. The defined process, using the materials and equipment specified, should be shown to yield a product consistently of the required quality.
- 5.23 Significant amendments to the manufacturing process, including any change in equipment or materials, which may affect product quality and/or the reproducibility of the process should be validated.
- 5.24 Processes and procedures should undergo periodic critical revalidation to ensure that they remain capable of achieving the intended results.

These principles are quoted here because they have survived, completely unchanged, in the most recent version of the PIC's *Guide to Good Manufacturing Practice of Medicinal Products* [7] and because the geographic range of influence of this particular guide is growing.

In the series of yearly PIC seminars aimed at fostering uniform inspection systems and mutual confidence, the seminar held in Dublin in 1982 was devoted to the theme of *theory and concepts in validation* [8]. It seems that at that time, other items on the agenda were more urgent than developing a PIC guidance document for validation.

An overview of regulatory and industry GMP documents issued before 1990 and their inclusion of validation elements is shown in [Table 1](#).

### III. REGULATORY GUIDANCE FROM THE 1990s ONWARD

#### A. U.S. FDA

As one of its *Guides to Inspections*, the FDA introduced *Guide to Inspections: Validation of Cleaning Processes* in 1993 [9]. This broadened the area of validation considerably by focusing on fields other than the manufacturing process itself. As time showed, further additions, such as *Test Method Validation* and *Computerized Systems Validation*, developed as validation topics on their own. The regulations and literature for these specialized fields will not be discussed here. The reader is invited to consult the relevant chapters of this book where the information is available.

In the 1990s, validation topics became a focus of FDA inspectors in the United States and abroad. Thanks to the *Freedom of Information Act*, interested industry members were able to follow the impact it made on the observations

written down in the forms 483, the official compilation of findings in an FDA inspection. An even stronger tool to enforce CGMP was the *warning letter*. A breakdown of the main deficiencies mentioned in 101 warning letters sent out in 1997 is a typical example of the importance attributed to all aspects of validation. (See Table 2.)

The FDA was aware of the discrepancy between the attention validation got in the enforcement through inspection and the role it played in the CGMP regulations written down in the CFR. In 1996, the FDA proposed a revision to update the requirements on process and methods validation and to reflect current practice by incorporating guidance previously issued to industry [11]. The revision, however, drew heavy criticism from industry for several reasons. The most prominent weaknesses with regard to validation were

1. The invention of new terminology that was at odds with commonly accepted practice; e.g., *demonstration of suitability* for equipment and processes instead of qualification and validation
2. The “overkill” policy of including sampling, weighing, labeling, etc. in the processes to be validated
3. The requirement for a batchwise routine testing of blend uniformity
4. Too much detail in certain parts; e.g., on the procedures to deal with *out-of-specification* (OOS) results.

**Table 2** Validation Deficiencies Mentioned in 101 Warning Letters Issued by U.S. FDA in 1997

Areas with serious deficiencies	In number of letters
Process validation	35
Cleaning validation	15
Analytical/test method validation	9
Water systems validation	6
Equipment installation/operational qualification	5
Sterilization process validation	4
Reworking/reprocessing validation	3
Validation protocol/documentation	3
Computer system validation	2
Aseptic filling validation	2
Container/closure system validation	2
Environmental monitoring validation	1

Source: Ref 10.



It was also apparent that the FDA's concept of validation at that time was out of tune with general pharmaceutical in practice. In the pharmaceutical community, *process validation* had become the term for the activity focusing on the manufacturing process as such. Other areas with a defined meaning are *cleaning validation*, *computerized systems validation*, *sterilization validation*, *equipment and support systems qualification*, and *analytical method validation*. The FDA continued to distinguish only between process and analytical method validation. Five years after the proposal, a final version of the amendments to CGMP has still not been published.

## B. PIC/S

After 1993, PIC in the original form of a treaty was no longer feasible for EU members because only the European Commission (EC) was authorized to sign agreements with other countries outside the EU. Since it was felt that the cooperation had proven to be useful, a new construct was found in the PIC scheme, abbreviated as PIC/S. This scheme started operating in 1995 as an informal arrangement between the national agencies with the focus on harmonization of GMP, training of inspectors, and development of guidelines. At the present time, PIC and PIC/S exist side by side.

The membership of participating countries in PIC/S and the EU is shown in [Table 3](#).

Table 3 shows that PIC/S is not only growing in Europe, but now includes Australia, Canada, Malaysia, and Singapore, while additional European and non-European health authorities are also interested in joining.

Countries presently preparing for membership in the EU are also aligning their drug registration procedures with those of the EU. The medicines agencies of the eastern-European countries have associated under the umbrella of CADREAC, the *Collaboration Agreement of Drug Regulatory Authorities in European-Union-Associated Countries*, to establish a counterpart to EMEA, the *European Medicines Evaluation Agency*.

The *Pan-European Regulatory Forum* (PERF) was created by the EU to bridge the cultural gap between the East and the West and to promote good scientific practice. Matters concerning GMP are an integral part of the topics discussed, besides pharmacovigilance and the accession countries' progress in adopting the body of EU legislation.

Since it could take up to 18 months for each of the EU countries' governments to ratify participation, the first candidates may not actually join the EU until 2004–2005. This means the harmonization of pharmaceutical markets in Eastern Europe with those in the EU will continue to be a gradual process. The first wave of candidates are Hungary, Poland, the Czech Republic, Estonia,

**Table 3** Membership Situation with PIC/S and EU from 1.01.2002

PIC/S members only	EU and PIC/S members	Future PIC/S members, accession in process	Interest in PIC/S membership declared
Australia	Austria	Chinese Taipei	Bulgaria
Canada	Belgium	Estonia	Lithuania
Czech Republic	Denmark	Latvia	Oman
Hungary	Finland	Poland	Thailand
Iceland	France		United Arab Emirates
Liechtenstein	Germany		
Malaysia	Greece		
Norway	Ireland		
Romania	Italy		
Singapore	Netherlands		
Slovak Republic	Portugal		
Switzerland	Spain		
	Sweden		
	United Kingdom		

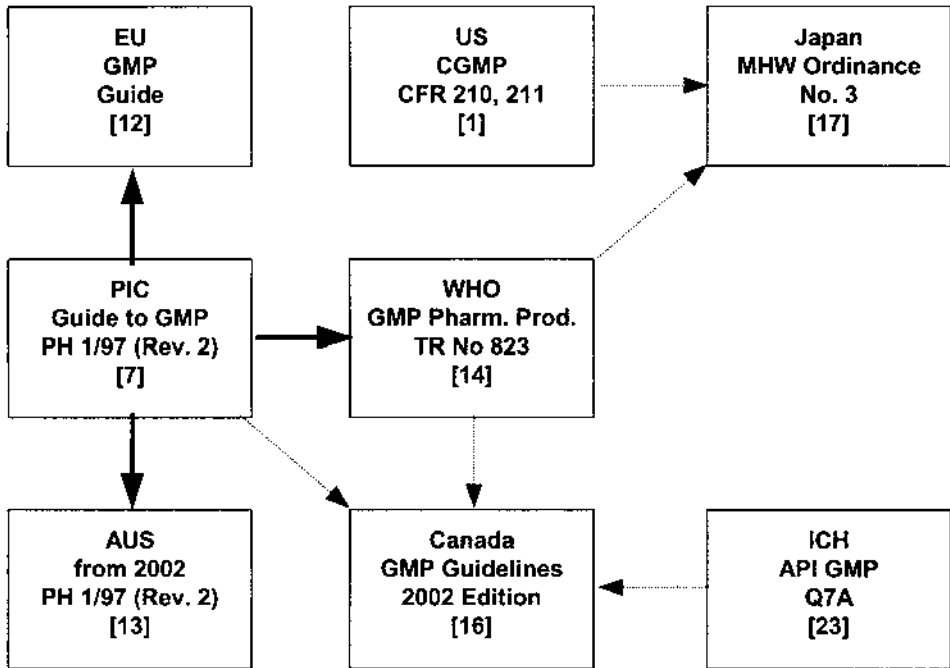
Slovenia, and Cyprus. Six other countries are expected to join later in the decade—Bulgaria, Lithuania, Latvia, Romania, Slovakia, and Malta.

### C. The World Health Organization

The WHO is an intergovernmental organization with some 190 member states. Since its inception in 1948, it has been involved in several long-standing activities concerning the development, production, quality assurance, safety, and efficacy of medicinal products with direct relevance to regulators, industry, and academia. It has an explicit responsibility to promote initiatives directed toward international harmonization of standards wherever and whenever this is appropriate within the health sector. It issued GMP guidelines in 1969 and revised them in 1975 and 1992. The WHO should have been the ideal candidate for an impartial body to serve as the flagship of harmonized GMP rules. National pride and juridical peculiarities, however, prevented major players from giving up their domestic model and moving toward such a common GMP framework.

### D. GMP Guidance in Comparison

Looking at the GMP requirements today, the diversity of the guides is not as pronounced as it seems. Fortunately, some of them are very similar. [Figure 1](#) attempts to characterize the similarity by the weight of the connecting arrows; the EU GMP guide 2001 [12] and the Australian guide [13] from 2002 onward



**Figure 1** Relationships among major national and regional guidelines on GMP.

are identical triplets of the PIC guide to GMP [7]. The WHO's technical report no. 823, *WHO Guidelines on Good Manufacturing Practices for Pharmaceutical Products* [14], is basically the PIC guide with some sections expanded to give more detailed explanations rather than bringing in new elements [15].

Relationships are looser in some countries. The health authority of Canada claims that the Canadian GMP guidelines of 2002 [16] have been revised in line with the PIC and the WHO guides as well as the GMP guide on APIs produced by ICH. (See below.) The *Japanese Ministry of Health, Labor, and Welfare* (MHLW) explains that ordinance no. 3 as the legal base for GMP requirements in Japan [17] has been drawn up taking into account both the relevant paragraphs of the U.S. CFR, parts 210 and 211, as well as the WHO guide.

### **E. Guidance on Process Validation**

An overview of the elements of validation mentioned or being dealt within some major official guidance validation documents is shown in [Table 4](#). Empty circles are used for topics that have been mentioned without further explanation, while filled circles indicate topics that give more room.

**Table 4** Official Guidance on Process Validation

Items mentioned or discussed	Document					
	U.S. FDA, guidelines on process validation	Annex 5 to WHO GMP guide [18]	Japanese MHW PAB notification 158 [19] and 660 [19a]	Recommendation on validation PIC/S 1/99-2 [21]	Annex 15 to EU GMP guide [22]	<i>Validation Guidelines</i> , Canada [20]
<i>Scope</i>						
Finished pharmaceuticals	●	●	●	●	●	●
Medical devices	●	—	—	—	—	—
Nonsterile processes	●	●	●	●	●	●
Active pharmaceutical ingredients API	—	(●)	●	—	—	—
<i>Topics</i>						
Design qualification	—	—	—	—	○	—
Installation qualification	●	○	○	●	○	●
Calibration	○	○	○	○	○	—
Operational qualification	—	○	●	●	○	●
Performance qualification	—	—	○	—	○	—
Qualification of established equipment	—	—	—	○	○	○
Requalification	—	—	—	○	—	—
Process validation	●	●	●	●	●	●

Prospective validation	●	●	●	●	●	●
Retrospective validation	●	●	●	●	●	●
Concurrent validation	—	●	●	●	●	●
Revalidation	○	●	●	●	○	●
Periodic review of validated systems	●	●	○	—	—	—
Change control	—	○	—	●	●	○
<b>Documents</b>						
Validation master plan	—	—	—	●	●	○
Validation protocol	○	●	●	●	●	○
Validation report	—	●	○	●	—	○
Formal release after qualification	—	—	—	○	○	○
<b>Management</b>						
Terminology	●	○	○	●	●	●
Responsibility	—	—	●	●	—	—
Timing	—	—	—	●	—	—
Organization	—	●	—	—	—	—

Note: ● item dealt with; ○ item mentioned; — item not contained.

In 1993 the WHO issued Annex 5 to its GMP guide, entitled *Guidelines on the Validation of Manufacturing Processes* [18]. The text explains and promotes the concept of validation and assists in establishing priorities and selecting approaches for developing a validation program. It starts from the experience that few manufacturing processes contain steps that are not critical; that is, may not cause variations in the final product quality. A prudent manufacturer is therefore advised to validate all production processes and supporting activities, including cleaning operations.

The *Japanese PAB notification no. 158* [19] and No. 660 [19a] detail the obligation of pharmaceutical manufacturers by defining the validation standards enforced from 1996 onward. The purpose of validation is presented as follows: “to validate that buildings and facilities of a manufacturing plant and manufacturing procedures, processes and other methods of manufacturing control and quality control yield anticipated results, and to ensure the constant manufacture of products of intended quality by documenting such procedures.”

The notifications list the duties of the validation manager as requested by article 10 of the control regulations. A concrete comparison of the notification with other countries’ requirements is difficult due to the nature of the translation process; for example, the interpretation of *synchronous* validation as being equivalent to *concurrent* may be misleading.

The latest addition to the guidance documents are the Canadian *Validation Guidelines for Pharmaceutical Dosage Forms* issued in 2000 [20]. They are unique with regard to the description of three phases of validation. This addresses the confusion that has been caused by the double meaning of process validation as used by FDA. It covers, on the one hand, the all-encompassing activities starting with the identification of critical variables in worst-case studies through equivalence of final formulation with biobatches to change control for the marketed product. On the other hand, it is restricted to the formal exercise of examining three batches at production scale.

Finally, [Table 5](#) shows a difference between document PIC/S 1/99-2 [21], *Recommendations on Validation Master Plan, Installation and Operational Qualification, Non-Sterile Process Validation and Cleaning Validation*, and Annex 15 to the EU GMP guide on the same topics [22]. Other than this pair of documents, the PIC/S and EU guides and their annexes are almost identical.

The PIC/S recommendations were issued as a draft in 1996. They were finalized in 1999, and are now in force as PIC/S 1/99-2. They were written as instructions for the inspectors with the aim of establishing a common philosophy of the validation topics. When they were proposed to be annexed to the EU GMP guide the discussion and ensuing revision led to a considerable reduction of the content since it was felt that the tutorial tone was not adequate for a regulation.

In Annex 15, the scope was limited to drug products only (omitting APIs), and references to process capability studies (that had not really been given

enough attention) were deleted. Interestingly, the following two elements were added that were not present in the PIC/S document:

1. Risk assessment was identified as an important tool in defining the elements and the extent of validation and qualification.
2. The use of the term *design qualification* (from medical services) was added, albeit with the semantically important softer term, *could* instead of the usual *should*.

#### **IV. HARMONIZATION: FROM WISHFUL THINKING TO REALITY**

##### **A. ICH**

In the 1990s, harmonization around the world got going when the ICH proved to be effective in bridging many of the gaps that existed in almost all parts of the documentation required for new drug applications. The optimism fueled by successful introduction of the first round of harmonized documentation helped overcome the inertia that had so far beset the international scene.

The *International Conference on Harmonization of Technical Requirements for the Registration for Pharmaceuticals for Human Use* is a tripartite initiative by the EU, Japan, and the United States to harmonize the regulatory guidelines in these three regions in order to reduce duplication and redundancy in the development and registration of new drugs.

One of the key elements for its success is most probably the composition of the organization. It was founded in 1990 as a joint regulatory/industry initiative. The six cosponsors are the EC and the EFPIA (*European Federation of Pharmaceutical Industries' Association*) for the EU, the MHLW and JPMA (*Japan Pharmaceutical Manufacturers Association*) for Japan, and the U.S. FDA and PhRMA (*Pharmaceutical Research and Manufacturers of America*) for the United States.

In addition to the active sponsors, WHO, EFTA, and Canada are taking part as observers. The IFPMA (*International Federation of Pharmaceutical Manufacturers Association*) runs the ICH secretariat and sits on the steering committee.

The objectives of ICH as laid down in their terms of reference in their early years were

To provide a forum for constructive dialog between and among regulatory authorities and the pharmaceutical industry on the real and perceived differences in the technical requirements for product registration in the EU, the United States, and Japan

To identify areas in which modifications in technical requirements or greater mutual acceptance of research and development procedures

could lead to a more economical use of human, animal, and material resources without compromising safety

To make recommendations on practical ways to achieve greater harmonization in the interpretation and application of technical guidelines and requirements for registration.

Progress is monitored by the committee and at biannual conferences. The ICH has been highly successful in delivering on these promises, going through the stages of ICH1 (Brussels, 1991) to ICH5 (San Diego, 2000). The objectives have been slightly amended for the second phase started after ICH4, but their main content remains the same. The next milestone, ICH6, is planned in Osaka in November 2003.

The topics being addressed in the context of registration of drugs for human use come from the three main themes safety (S), efficacy, (E), and quality (Q). Other topics have been subsumed under multidisciplinary (M). The main focus of ICH is on the studies and documentation needed for submissions for marketing approval to the health authorities.

Recently the CTD (the *Common Technical Dossier*) and its electronic format (the eCTD) have caught most of the attention. The ICH has also moved into the GMP arena as well, with the development of the global *Good Manufacturing Practice Guide for Active Pharmaceutical Ingredients* [23].

The development of GMP guidance for API manufacturers was anything but straightforward. Altogether at least five major attempts in 7 years were made by national and supranational bodies to arrive at a harmonized document. In the end, none of them was found good enough to be accepted by all the other parties. An ICH expert working group Q7 was established, consisting of 20 members: two from each of the six members of ICH, the generics industry (IGPA), and the OTC industry (WMSI); one representative from Australia, China, and India; and three observers (WHO, Canada, and Switzerland).

This GMP guide is probably the first that will be enforced in three regions and beyond (see composition of working group) without local variations and thus bring with it full harmonization. It reached step 4 at ICH5 in 2000, and has since been transferred into the local legal and regulatory framework by the three regions.

One of the key issues in this guide is the question "When does GMP start?" Although there is no simple answer that fits all cases perfectly, the guide has helped to decrease the uncertainty around this central problem. Another timely bit of progress is the inclusion of validation concepts that have been missing in the other GMP guides.

All the major objectives with regard to Quality Guidelines have been finalized. Some of the harmonized rules have already successfully gone through a first revision process. An overview is given in [Table 5](#).



**Table 5** Quality Guidelines Harmonized by ICH

Quality topic	Guidelines
Q1: Stability	Q1A(R): Stability testing of new drugs and products (revised guideline)
	Q1B: Photostability testing
	Q1C: Stability testing of new dosage forms
	Q1D: Bracketing and matrixing designs for stability testing of drug substances and drug products
	Q1E: Evaluation of stability data (in consultation)
	Q1F: Stability data package for registration in climatic zones III and IV (in consultation)
Q2: Validation of analytical procedures	Q2A: Text on validation of analytical procedures: definitions and terminology
	Q2B: Methodology
Q3: Impurity testing	Q3A(R): Impurities in new drug substances (revised guideline)
	Q3B(R): Impurities in new drug products (revised guideline, in consultation)
	Q3C: Impurities: guideline for residual solvents
	Q3C(M): Impurities: guideline for residual solvents (maintenance, in consultation)
Q4: Pharmacopoeias	Q4: Pharmacopoeial harmonisation (work ongoing)
Q5: Quality of biotechnological products	Q5A: Viral safety evaluation of biotechnology products derived from cell lines of human or animal origin
	Q5B: Analysis of the expression construct or cells used for production of r-DNA derived protein products
	Q5C: Stability testing of biotechnological/biological products (annex to Q1A)
	Q5D: Derivation and characterisation of cell substrates used for production of biotechnological/biological products
	Q5E: Derivation and characterisation of cell substrates used for production of biotechnological/biological products
Q6: Specifications for new drug substances and products	Q6A: Test procedures and acceptance criteria for new drug substances and products: chemical substances
	Q6B: Test procedures and acceptance criteria for biotechnological/biological products
Q7: GMP for pharmaceutical ingredients	Q7A: Good manufacturing practices for active pharmaceutical ingredients

The success of the GMP guidance for APIs has led some enthusiasts to request a similar exercise (Q7B) for excipients. The reason why this could become an unnecessary duplication follows from the achievements made by the *International Pharmaceutical Excipients Council (IPEC)*.

## **B. IPEC**

The IPEC started as an informal discussion session, during the *Joint Pharmacopeial Open Conference on International Harmonization of Excipients Standards* in Orlando (1991). It has evolved into an organization with approximately 100 full member companies, excipient manufacturers, and pharmaceutical users. It is structured in three partner organizations: IPEC-Americas, IPEC-Europe, and IPEC-Japan.

One of IPEC's greatest accomplishments has been the development of *new excipient safety evaluation guidelines*. Previously, there were no generally accepted safety evaluation processes for excipients anywhere in the world. The IPEC guidelines fill this void.

The second product of IPEC, the one relevant to this context, is the comprehensive, harmonized *Good Manufacturing Practice Guide for Bulk Pharmaceutical Excipients (BPE)* [24], which was intended for global use and was presented in 1995 after a sustained 4-year effort. The factors that motivated IPEC to develop this guide were that no national body had adopted GMP regulations specifically applicable to pharmaceutical excipients. Since European and many Asian excipient manufacturers and regulatory bodies have embraced the ISO concept (see below), it made sense to merge the requirements of the ISO 9000 series with drug GMP. The IPEC used FDA's drug CGMPs as a base. The IPEC GMP guide for BPEs is applicable to the manufacture of all excipients intended for human and veterinary drugs and biologics. It covers the quality systems and the extent of GMP that are necessary throughout the production chain to customer delivery. It has been integrated into the U.S. Pharmacopeia (USP) as well [25].

It is the responsibility of the manufacturer of drug products to ascertain and certify that each component in the finished drug was produced, delivered, and handled in accordance with GMPs. To meet this obligation, pharmaceutical companies perform regular audits at each of its suppliers' facilities, an expensive exercise for both.

Based on the GMP BPE guide, IPEC developed an audit guide and checklist [26], which is used to train and direct a selected auditing group similar to the approach taken by the ISO. This third party program was presented by IPEC in 2000. It provides for either an excipient manufacturer or a pharmaceutical company purchaser to request the third party assessment. The requesting firms pays for the audit. After performing the audit the findings are documented in

accord with the IPEC checklist. The audit report is available to other firms who may want to purchase a copy of it (if the audited supplier has not vetoed further dissemination). The advantage for the excipient supplier will be that the number of inspections on his premises may be drastically decreased and that the extent and depth of inspections will get more standardized. For the excipient purchaser the costs for supplier auditing is substantially reduced.

Looking at the relative amounts of excipients and actives generally present in a drug product one wonders why GMP should be so much more important for the minor or, quite often, most minute part of the medicine taken by the patient. Only recently, the concern about transmission of *bovine spongiform encephalopathy* (BSE) has brought excipients such as gelatin and tallow to the same level of attention as APIs, so it is only natural to have the GMP concept apply equally to all ingredients. The EU authorities had indicated that they wanted to come up with a new guide for starting materials applicable to all ingredients of a dosage form, actives and inactives, in 1999. It seems that they have now settled on going with the ICH API GMP guide. This is welcomed, as it avoids disruption in a major harmonization process.

### C. Pharmacopeias

The activities of ICH and IPEC have also brought to the attention of both industry and regulators worldwide the realization that international harmonization of pharmaceutical registrations cannot take place without international harmonization of compendial standards for APIs and excipients. The *Pharmacopeial Discussion Group* (PDG) was formed in 1989 as a voluntary alliance of the three Pharmacopeias: the USP, *European Pharmacopeia* (EP), and *Japanese Pharmacopeia* (JP). The work was split between the three pharmacopeias. The work is done by international technical working groups. A time-intensive seven-step procedure is followed. When finished, draft monographs appear in the publication organs *Pharmacopoeial Forum* (USP), *Japanese Pharmacopoeial Forum* (JP), or *Pharmeuropa* (EP).

The PDG has published the following policy statement on harmonization:

The goal of harmonization is to bring the policies, standards, monograph specifications, analytical methods and acceptance criteria of these pharmacopeias into agreement. The policy recognizes the value of unity, i.e. a single, common set of tests and specifications, policies, and general methods, but recognizes that unity may not always be achievable. Where unity cannot be achieved, harmonization means agreement based upon objective comparability and a clear statement of any differences. The goal, therefore, is harmony, not unison.

The harmonization effort encompasses not only monographs for individual excipients but also general tests. An overlap with notorious GMP and validation

topics exists, for example, in the field of content uniformity and its companion, blend uniformity.

#### **D. The International Organization for Standardization**

The ISO is a multinational agency embracing a segment much larger than the pharmaceutical industry. It was established in 1947 as a worldwide federation of national standards bodies and today comprises more than 140 member countries. The purpose of ISO is to promote harmonization of processing, manufacturing, and quality assurance standards among industrial nations. More than 30,000 experts from all over the world participate in the technical work in 222 technical committees. The output is the impressive figure of over 13,000 ISO standards.

Only two groups of documents from the very broad scope of this organization are mentioned here. The first one is the ISO 9000, *Quality Systems and Management*, and the other series is the output of the technical committee 209, *Cleanroom Technology*.

##### **1. The ISO 9000 Series**

The ISO 9000 series was developed in 1987, finalized in 1990, and reissued in 1994 as a comprehensive set of standards governing the management of quality for all industries. It has rapidly become very popular with many types of industrial operations since the certification according to ISO 9000 was a seal of excellence proudly displayed by those who had obtained it.

Because of this, the discussion became quite heated some years ago about the relationship between ISO 9000 quality requirements and GMP requirements. A lot of the confusion and controversies originated from a poorly structured question such as: Should a pharmaceutical manufacturer or supplier already in tune with GMP be ISO 9000 certified?

Put into the right framework, the following questions should have been studied and answered separately:

1. Is there a major difference between the ISO quality system requirements and GMP requirements?
2. If the answer to question 1 is “yes,” is there a need for a pharmaceutical company engaged in the R&D, manufacture, or supply of drug products to add the elements of an ISO quality system that are not covered by GMP?
3. Is there a reason for company X to get an ISO certification of the quality system because it might represent a competitive advantage?

Question 1 has been studied by several authors [27–29], and corresponding comparison tables have abounded. A general conclusion in a nutshell is the

following. The ISO 9000 standard is more systematic in approach and structure. It is broader since it also encompasses the design stage. Apart from these differences, reasonable correspondence between the remaining items and GMP standards can be demonstrated. The more comprehensive ISO 9000 approach was taken into account during recent revisions of GMPs, such as those of excipients by IPEC as well as for the *Medical Devices Quality Systems Regulations* of U.S. FDA [30].

As it turned out, in general, pharmaceutical drug manufacturers already operating under GMP did not expect a marked benefit from being officially ISO 9000 certified. As a commonsense approach to take and combine the best of ISO and GMP, however, the use of a quality management system along the structure proposed by ISO 9000 became accepted practice in the industry. Manufacturers of API, on the other hand, and producers and suppliers of bulk chemicals, found the idea of getting the ISO 9000 certification quite attractive.

## 2. ISO 9001:2000

The series 9000 has undergone significant revision and has been streamlined. Instead of the different depths of business activities of the former standards 9001–9004, there is just one: ISO 9001:2000. It covers the full range from design through development, manufacturing, and production to supply and service. The three series 9000 documents now are

1. 9000:2000 Quality management systems—fundamentals and vocabulary
2. 9001:2000 Quality management systems—requirements
3. 9004:2000 Quality management systems—guidelines for performance improvement

In the new 9001:200 standard there are several new requirements designed to ensure a higher focus on the end user. In addition, the revised standards series places greater emphasis on the role of top management to develop and improve its operational systems and establish measurable objectives at appropriate levels throughout the organization.

To maintain the voluntary accreditation, all organizations eventually will have to be certified within the ISO 9001:2000 standard. Organizations have 3 years (until the end of 2003) to become compliant. The transition from the former to the current version of ISO 9000 is not only a matter of deploying sufficient resources to get it done. The U.S. FDA does not plan to modify its 6-year-old *quality systems regulations* (QSR) for medical devices. The existing QSR, modeled after the 1994 versions of ISO 9001, had adopted preproduction controls to ensure a safe, effective product. It had the further advantage of aligning the United States with worldwide regulatory requirements. ISO 9001:2000

deleted or relaxed some requirements for documentation that the FDA considers important, however, while adding others, such as customer satisfaction, that the agency considers too subjective to be regulated. As a result, there is no indication that FDA will be changing its QSR to align it with ISO 9001:2000. As a matter of fact, the medical device sector has drawn up its own standard, ISO 13485. It will be ready to be published in 2002 [31].

### 3. The ISO 14644 and 14698 Series

GMP codes have to remain generic and cannot (and should not) go into all the technical details of operating and maintaining manufacturing facilities. More technical guidance is needed to guarantee sterility of the final products, however. Unfortunately, there is much diversity in the national standards providing this degree of detail.

In 1990, the technical committee *CEN/TC 243 Cleanroom Technology* was established under the umbrella of CEN, the *European Committee for Standardization* (founded by EU and EFTA). In 1991, the ISO/TC 209 was inaugurated at the request of the *American National Institute for Standardization* (ANSI).

Through an agreement in Vienna in 1991, CEN and ISO have cooperated in the following way. Since both technical committees targeted standardization of cleanroom specifications they were merged to form the committee *ISO/TC 209, Cleanrooms and Associated Controlled Environments*. Draft standards are submitted to ISO and CEN bodies at the same time. If approved by CEN, the standard will become a mandatory national standard of all the European states and existing conflicting requirements have to be withdrawn. If approved by ISO, the member states (outside Europe) can adopt the standard if they want to do so.

The standardization effort of ISO/TC 209 is split into two families of standards.

1. The ISO 14644 series covering general contamination control topics
2. The ISO 14698 series on biocontamination control issues.

Of the seven 14644 documents, three were issued by the end of 2001. The other four are in different stages of being drafted. In November of 2001, the United States decided to replace *Federal Standard 209E* with ISO 14644: *Cleanrooms and Associated Controlled Environments: Part 1: Classification of Air Cleanliness* (ISO 14644-1) and *Part 2: Specifications for Testing and Monitoring to Prove Continued Compliance with ISO 14644-1* (ISO 14644-2). (See [Table 6.](#))

The third 14644 core document, *Metrology and Test Methods* (ISO 14644-3, comprising more than 100 pages), is expected to be finalized in 2002.

**Table 6** ISO Cleanroom Standards

Title of the ISO cleanroom standard	Number and status
Cleanroom and Associated Controlled Environments	
Part 1: Classification of Airborne Cleanliness	EN/ISO 14644-1:1999 Published Standard
Part 2: Specifications for Testing Cleanrooms to Prove Continued Compliance with EN/ISO 14644-1	EN/ISO 14644-2:2000 Published Standard
Part 3: Metrology and Test Methods	EN/ISO 14644-3 Comm. Draft 1998
Part 4: Design, Construction and Start-up	EN/ISO 14644-4:2001 Published Standard
Part 5: Cleanroom Operation	EN/ISO 14644-5 Draft Int. Std. 2001
Part 6: Terms, Definitions and Units	EN/ISO 14644-6 Comm. Draft 2001
Part 7: Separative Devices, Glove Boxes, Isolators and Mini Environments	EN/ISO 14644-7 Draft Int. Std. 2001
Cleanroom Technology; Bio-Contamination Control	
Part 1: General Principles and Measurement of Bio-contamination of Air Surfaces, Liquids and Textiles	ISO 146698-1 Draft Int. Std. 2:2002
Part 2: Evaluation and Interpretation of Bio-contamination Data	ISO 146698-2 Draft Int. Std. 1999
Part 3: Methodology for Measuring the Efficiency of Cleaning and/or Disinfection Processes of Inert Surfaces Bearing Bio-contaminated Wet Soiling or Bio-films	ISO 146698-3 Draft Int. Std. 1999

In general, the IS series of cleanroom standards support the GMP guidance of the regulatory authorities, but with one important exception: air cleanliness classification for airborne particles. The air cleanliness classification scheme according to ISO 14644-1 is based on a coherent approach described by a mathematical formula (shown in the chapter “[Qualification of Water and Air Handling Systems](#),” by K. Kawamura).

Unfortunately, the requirements listed in the EU GMP guide (Annex 1) for particles of 5  $\mu\text{m}$  and above deviate from scientific logic quite fundamentally. For the room grades A and B (i.e., for the aseptic core and its environment) the European GMP guide sets a concentration limit of zero particles per  $\text{m}^3$ . Interpreting zero as  $<1$  per  $\text{m}^3$ , a total of 135 consecutive samples with zero count would have to be taken in order to meet this limit with 95% confidence—an impractical proposition, considering that this determination has to be repeated at each sampling location [32].

It is to be hoped that this and some other remaining discrepancies will be addressed in the next revision of the Annex 1 to the EU GMP guide. This example illustrates how one round of harmonization or standardization triggers a new round of changes in other sets of standards.

## E. PDA

The *Parenteral Drug Association* (PDA) is an international association promoting the art and science of pharmaceutical technology and high standards for products, the dissemination of information, and the support of education and training. Among its well-appreciated merits is engaging in the dialogue between industry and regulators by specific comments to proposed legislation on the one hand and arranging for meetings with participation of all those involved in establishing and applying standards on the other hand.

Among its outputs, the technical reports are of special interest in this context. They contain recommendations for solutions in different areas of developing and manufacturing pharmaceutical products representing the state of the art and complying with the CGMPs. Due to the international character of the association and the involvement of all parties, these guidance documents reflect a globally harmonized interpretation of regulations. (See [Table 7](#).)

Based on technical report 32, PDA has established a third party inspection program in the field of software suppliers. It works like the one described for IPEC's BPE GMP audits. By March 2002, 117 auditors had been certified, and the audit repository center, as the service provider licensed by PDA, lists 22 audit reports [33].

The PDA also has a GMP harmonization task force. Its job is to assess the differences in GMP definition and implementation. After scanning several hundred documents prepared in the United States or Europe, two preliminary observations have been made public [34].

1. There was not as much overlap as the group had expected. Regulators in the United States and Europe have found it necessary to concentrate on different areas of GMP compliance.
2. Much of the U.S. guidance is more dated, in some cases 10 to 15 years old. EU guidance is more recent.

## F. ISPE

The *International Society for Pharmaceutical Engineering* (ISPE) is a worldwide nonprofit society of technical professionals who apply their technical knowledge in the regulated health care technology manufacturing industries. The ISPE is committed to advancing the educational and technical proficiency



**Table 7** Selected PDA Guidance Documents on Validation and Qualification

PDA technical reports title	Number	Year published
Validation of Steam Sterilization Cycles	1	1978 Under revision
Validation of Dry Heat Processes Used for Sterilization and Depyrogenation	3	1981
Design Concepts for the Validation of a Water-for-Injection System	4	1983
Sterilization of Parenterals by Gamma Radiation	11	1988
Fundamentals of a Microbiological Environmental Monitoring Program	13	2001 Revised
Industry Perspective on the Validation of Column-Based Separation Processes for the Purification of Proteins	14	1992
Industrial Perspective on Validation of Tangential Flow Filtration in Bio-pharmaceutical Application (01015)	15	1992
PDA Report on the Validation of Computer-Related Systems	18	1995
Bioburden Recovery Validation	21	1990
Process Simulation Testing for Aseptically Filled Products	22	1996
Industry Survey on Current Sterile Filtration Practices	23	1996
Blend Uniformity Analysis: Validation and In-Process Testing	25	1997
Sterilizing Filtration of Liquids	26	1998
Pharmaceutical Package Integrity	27	1998
Process Simulation Testing for Sterile Bulk Pharmaceutical Chemicals	28	1998 Under revision
Points to Consider for Cleaning Validation	29	1998
Parametric Release of Pharmaceuticals Terminally Sterilized by Moist Heat	30	1999
Validation and Qualification of Computerized Laboratory Data Acquisition Systems	31	1999
Auditing of Suppliers Providing Computer Products and Services for Regulated Pharmaceutical Operations	32	1999
Evaluation, Validation and Implementation of New Microbiological Testing Methods	33	2000
Design and Validation of Isolator Systems for the Manufacturing and Testing of Health Care Products	34	2001
Current Practices in the Validation of Aseptic Processing	36	In process
Validation of Biologic Manufacturing Processes	tbd	In process
Validation of Plasma Fractionation Processes	tbd	In process
Validation of Lyophilization Processes	tbd	In process

of its members through information, educational service, and forums for the exchange of ideas and practical experience.

The ISPE has developed guidance documents regarding planning, constructing, commissioning, qualifying, and operating facilities and systems for pharmaceutical manufacturing. It also established a baseline (i.e., commonsense minimum standards that reflect current laws or regulations).

There are six vertical guides that address specific types of facilities and three horizontal guides that apply to all types of facilities. (See Table 8.)

The ISPE is distributor of the *GAMP Guide for Validation of Automated Systems*, currently in its fourth edition [35]. GAMP 4 (GAMP = *good automated manufacturing practice*) gives guidance to the suppliers of automated systems to the health care industries on the development and maintenance of all types of automated systems following good practice. The exchange of experiences and ideas in preparing the material and keeping it up to date has helped to standardize evolving validation concepts and approaches. It has facilitated building a knowledge base for consistent practices on a pragmatic level, thereby reducing variability.

Furthermore, ISPE is in the process of establishing guidance on process transfer. This is the result of a collaboration with the U.S. FDA and the *American Association of Pharmaceutical Scientists* (AAPS), with input from European regulatory authorities and the Japanese MHLW. This *technology transfer guide* is designed to present a standardized process and recommends a minimum base of documentation in support of the transfer request.

## G. MRAs

Pressure for harmonization also comes from the political front, fueled by interests to remove existing barriers to free trade. Whereas the European countries

**Table 8** ISPE Guidance on Topics Related to Validation and Qualification

Title of the ISPE Baseline pharmaceutical engineering guide	Type	Year published
Bulk Pharmaceuticals Chemicals	Vertical	1996
Oral Solid Dosage Forms	Vertical	1998
Sterile Manufacturing Facilities	Vertical	1999
Biotechnology	Vertical	Under development
Oral Liquids and Aerosols	Vertical	—
R&D Facilities	Vertical	—
Water and Steam Systems	Horizontal	2001
Commission and Qualification	Horizontal	2001
Packaging and Warehousing	Horizontal	Under development

and the non-European members have used PIC/S as the vehicle for mutual acceptance of GMP standards and inspections, other countries have yet to come to such agreements.

Previously, there were *memoranda of understanding* (MoU) on GMP inspections concerning the U.S. FDA and Sweden, Switzerland, and Canada. These are on hold after FDA decided that most foreign audit programs did not meet U.S. regulatory standards.

During the last 3 years, bilateral *mutual recognition agreements* (MRAs) have been enacted among many nations. Pharmaceuticals are often only a small part of the deal to facilitate trade between partners. For drug substances or drug products the importing country wants to be assured that the same GMP rules have been applied as if the substance or product were manufactured in its own country. As a prerequisite, the system of controlling the industry's compliance with all regulatory requirements has to be equivalent between the countries. Since many aspects have to be covered when establishing equivalence, this is no trivial task.

This is painfully illustrated by the fate of the MRA between the United States and the EU. It proved to be a difficult undertaking right from the start. The parties tried to come to a common definition for GMPs, but finally had to agree to disagree. Furthermore, the confidentiality of inspection reports in the European understanding clashed with the public availability of FDA inspection observations in the form 483 under the *Freedom of Information Act*. The FDA wanted to obtain inspection reports in every case, preferably in one of the more popular languages. The format and extent of *essential information* in establishment reports will have to be decided in addition to the systems to be used for exchanging these reports.

Fortunately, some MRAs are progressing at a faster pace. [Table 9](#) shows the situation of some of the more important MRAs at the end of 2001.

A similar agreement to the MRAs is the *Protocol to the European Agreement on Conformity Assessment and Acceptance of Industrial Products* (PECA) made public by the EC in March 2002. It was prepared in order to facilitate the operation of the annex on GMP for medicinal products: inspections and batch certification to such PECAS. The type of information that should be exchanged between the EU and associated countries and the obligations with respect to joint inspections and inspector training are also delineated.

## **H. Validation Requirements for Submissions**

Adherence to GMP in general and, as part of it, proof of validation of critical processes and its documentation are generally seen as topics under scrutiny during inspections. The documentation of qualification and validation exercises during product and process development inevitably encompasses hundreds if not thousands of pages. It would seem obvious that it is not in the interest of

**Table 9** State of the MRAs Among Countries or Unions at the End of 2001

MRA partners	Entry into force	Equivalence evaluation	Start operation	GMP certification	Inspection report	Alert system	APIs
Australia–EU	Jan. 1999	None	Jan. 1999	Yes	Upon request	In operation	Yes
Canada–EU	Nov. 1998	Some issues outstanding	Sept. 2002 (?)	Yes	Upon request	In operation	No
EU–Japan	Feb. 2002	18-month period	Aug. 2003	No	Upon request	Under investigation	Under discussion
EU–New Zealand	Jan. 1999		Jan. 1999	Yes	Upon request	In operation	Yes
EU–Switzerland	June 2002	None	June 2002	Yes	Upon request	In operation	Yes
EU–United States	Dec. 1998	Ongoing; FDA lagging behind schedule	Overdue; new date not yet fixed	No	FDA wants it for all cases	In operation	Yes
PIC-PIC/S–members	May 1971 Nov. 1995	Training programs ongoing	May 1971 Nov. 1995	Yes	Upon request	In operation	Yes

the reviewer of a marketing application (NDA/ANDA) to be swamped by an excessively voluminous submission package.

From 1975 onward, however, the EU has requested experimental validation studies for a manufacturing process to be included in the application dossier where a nonstandard method is being used or where it is critical for the product (Council Directive 75/319/EEC [36] as amended by 91/356/EEC [37]). This requirement is amplified in the *Notice to Applicants* [38].

For some time, the opinion has been divided in the EU regarding the assessment of such validation steps. In many cases it was held to be the remit of the GMP inspectorate while member states would expect to see varying degrees of validation studies presented in support of application for marketing authorization. The guideline *Development Pharmaceuticals and Process Validation* [39] defined more clearly what the agency wants to see in the application dossier.

Since it is essential that only valid manufacturing processes be used, it is increasingly expected that data should be submitted in the application for marketing authorization demonstrating the validity of a given process. . . . This note for guidance is intended to demonstrate and standardize the data that should be routinely included in the marketing authorization dossier describing the evaluation or validation of the manufacturing process and distinguish them from those validation data which more properly fall under the remit of GMP inspection.

As if there needed to be more affirmation regarding the inclusion of data on validation in the application, the EMEA issued the *Note for Guidance on Process Validation* [40] prepared by the *Committee for Proprietary Medicinal Products* (CPMP). This came into operation in 2001.

It clearly expects to see a process validation protocol included in the submission. Validation data should be generated for all products. It is accepted, however, that the amount of data presented in the application dossier will to a certain extent depend on the nature and complexity of the drug substance, drug product, and manufacturing process.

Whereas it is accepted that validation data on the first production scale batches may not be available at the time of submission, it is considered essential that valid manufacturing processes are used and the data submitted in the application verify the validity of the process. Where production scale data are not available at time of submission, validation can be conducted in two steps: a thorough characterization of the critical process parameters at pilot scale (presented in the dossier), followed by a formal validation program on production scale for which a protocol is included in the dossier. An annex details the contents of such a protocol.

Such precedents are major setbacks for harmonization.

## V. MEDICAL DEVICES

This section is mainly based on a review article written by S. Hoff [41].

### A. National and Regional

In Europe, prior to the CE mark, medical devices were registered in individual countries, each having a set of specific registration requirements. In June 1993, the *Council of European Communities* issued the *medical device directive* (MDD), which has been transposed into national laws throughout the EC. The purpose of adoption of the MDD was to allow the health care industry to benefit from the advantages of a single European market and allow products to circulate freely in the EC without additional technical constraints issued by the various member states.

Since 1998, all medical devices marketed in Europe (EEA) must bear the CE mark, which signifies conformity to the essential requirements of the MDD. The MDD harmonized the European requirements along with device certification and the inspection procedures for manufacturers to ensure the highest degree of safety and product quality of the medical devices throughout the EC. Most important was the requirement for a full quality assurance system (Annex II of the MDD, 93/42/EEC), which included design controls for new medical device products. This was in line with the ISO 9000 series of standards established for quality systems by the International Organization for Standardization.

The guarantee of conformity to the essential requirements of the MDD is provided by the interaction between the manufacturer and a third party, the notified body. The notified bodies are organizations that are recognized by the member states to conduct device evaluations and inspections of the quality systems of the various manufacturers. The manufacturers are held responsible for the quality, safety, and effectiveness of their medical devices. This is enforced through the manufacturer's written declaration of conformity and commitment to keep all technical information available for inspection by the notified bodies and national authorities.

Revision of medical device regulations has occurred in other countries, including Canada and the United States, because of the European experience. In 1998, Canada changed its device regulations to include a risk-based classification system and 11 principles of safety and effectiveness, which were patterned after the essential requirements of the European MDD (22).

In the United States, revisions of the *GMP* regulations became effective in June 1997 under the *Code of Federal Regulations, Quality System Regulation* (21 CFR 820). This was the first GMP revision since 1978, and included changes to ensure that the new regulation was compatible with ISO 9000, such as preproduction design control and validation. It was felt that if quality-associ-

ated defects could be identified early in the development process, then large savings in resource and monetary expenditures could be expected. As written, the design control section of the regulation (21 CFR 820.30) describes requirements that are both broad and flexible. They do not tell a manufacturer how to design a product, but how to document the design phase. The new regulations thus open the door to FDA inspection of the product development process.

The *Food and Drug Administration Modernization and Accountability Act* of 1997 is also having some impact on the medical device industry. An *MRA* was finalized between the FDA and EU in June 1997 after 5 years of negotiations regarding inspections and product assessments for drugs and medical devices. Under this agreement, the FDA would recognize EU third parties or *conformance assessment bodies* (CABs), which would conduct quality system audits and premarket reviews to FDA standards. Also, the EU would accept FDA inspections and premarket reviews that used EU standards. A 3-year transition period is being used, during which joint confidence-building programs among FDA, EU authorities, and CABs will be conducted to educate all parties. The FDA and EU will conduct an equivalence assessment at the end of the transition period and determine what steps should be taken next under the *MRA*.

## **B. International**

Global harmonization of medical device requirements is growing in importance, as there is an ever-increasing number of medical device regulatory systems worldwide and more complex regulatory challenges resulting from advancing medical technology and the globalization of commercial markets. To address these challenges, the *Global Harmonization Task Force* (GHTF) was formed in 1992 with the goal of developing equivalent systems on a global basis for the regulation of medical devices. This group has representatives from more than 30 nations, including Australia, Canada, the EU, Japan, the United States, and non-EU countries (Croatia, Czech Republic, Estonia, Georgia, Lithuania, Malta, Norway, Poland, Russian Federation, Slovak Republic, and Turkey). The most recent efforts of this organization have been to

1. Increase communications by opening its Web site
2. Form a strong relationship with the ISO/TC210 committee, which is working to standardize the quality of medical devices
3. Reach closure on important harmonization documents, which are being produced by the various study groups
  - a. SG1-Regulatory Requirements/Premarket review
  - b. SG2-Medical Device Vigilance/Postmarket Surveillance
  - c. SG3-Quality System Requirements and Guidance
  - d. SG4-Auditing

The best demonstration of success for the GHTF will be the incorporation of the GHTF-endorsed harmonized requirements into existing regulatory systems by the various national competent authorities.

## VI. CONCLUSION AND OUTLOOK

After a period of mushrooming with many national varieties, GMP and validation have entered a phase of global consolidation. The concept of GMPs has converged on the *quality systems* approach rather than having quality assurance as the unique custodian of quality in addition to being an internal police force. Validation has become accepted as a tool to be used with common sense instead of a cover-it-all paper exercise. Risk assessment has been identified as the important core activity controlling the extent and depth of validation.

The movement in the global regulatory environment toward harmonization of the regulatory requirements for pharmaceuticals and medical devices during the 1990s was impressive. Health authorities have embraced the idea of facilitating the delivery of safe, effective, and high-quality drugs to the patient by finding common ground. The implementation of the ICH guidelines and the increased use of MRAs, as well as the activities of many international organizations, helps the pharmaceutical and medical device industries in developing new products under harmonized rules and supply them to a global market.

It would be premature, however, to state that the battle has been won, for several reasons. First, harmonized regulations on paper are only a first step. A second and more important one is the interpretation by those who enforce them. All those who have witnessed inspections know how much they depend on the individual doing the assessment. There are differences within one country, but even more between countries. Even when the rules on paper have been modified, the mindset is much slower to adapt to the changes. Reaping the benefits of harmonization in practice will lag behind the formal achievements.

Second, harmonization is a continuous process. Regulations keep changing, technologies develop, the targets are constantly moving. With an increasing density of laws and guidance documents and with new players entering the field, harmonization will become more and more complex and the revision processes more tedious.

Third, more sophisticated products and the public expectations of zero risk are driving up the cost of state-of-the-art medicines. At the same time, health care cost containment and demands for better access to pharmaceutical products from an aging population and from third world countries are forcing prices downward.

In the last 12 years, we have seen an exceptional job being done in the area of harmonization to the benefit of all. We definitely need more of this to



**Table 10** Internet Home Pages of the Organizations Mentioned

Organization	Web site (http:// . . .)
APV	<a href="http://www.apv-mainz.de">www.apv-mainz.de</a>
EC News	<a href="http://dg3.eudra.org/pharmacos/index.html">dg3.eudra.org/pharmacos/index.html</a>
EU GMP documents for download	<a href="http://dg3.eudra.org/F2/eudralex/vol-4/home.htm">dg3.eudra.org/F2/eudralex/vol-4/home.htm</a>
European Pharmacopoeia (EP)	<a href="http://www.pheur.org">www.pheur.org</a>
GHTF	<a href="http://www.ghtf.org">www.ghtf.org</a>
ICH	<a href="http://www.ifpma.org/ich1.html">www.ifpma.org/ich1.html</a>
IPEC	<a href="http://www.ipec.org">www.ipec.org</a>
ISO	<a href="http://www.iso.ch">www.iso.ch</a>
ISPE	<a href="http://www.ispe.org">www.ispe.org</a>
Japanese ministry (MHLW)	<a href="http://www.mhlw.go.jp/english/index.html">www.mhlw.go.jp/english/index.html</a>
PDA	<a href="http://www.pda.org">www.pda.org</a>
PIC/S	<a href="http://www.picscheme.org">www.picscheme.org</a>
US FDA	<a href="http://www.fda.gov">www.fda.gov</a>
US FDA, CDER Guidance Documents	<a href="http://www.fda.gov/cder/guidance/index.htm">www.fda.gov/cder/guidance/index.htm</a>
US FDA, CBER Guidelines	<a href="http://www.fda.gov/cber/guidelines.htm">www.fda.gov/cber/guidelines.htm</a>
US FDA Warning Letters	<a href="http://www.fda.gov/foi/warning.htm">www.fda.gov/foi/warning.htm</a>
United States Pharmacopoeia	<a href="http://www.usp.org">www.usp.org</a>
WHO	<a href="http://www.who.int">www.who.int</a>

cope with the challenges ahead of us and to make safe drugs available to all (Table 10).

## REFERENCES

1. U.S. Food and Drug Administration. GMPs, CFR 21, Parts 210 and 211 (1978).
2. U.S. Food and Drug Administration. *Proposed GMPs for Large Volume Parenterals*. CFR 21, Part 212 (1976).
3. U.S. Food and Drug Administration. *Guidelines on General Principles of Process Validation*. Rockville, MD: Division of Manufacturing and Product Quality, Center for Drugs and Biologics, (1987).
4. Diding, N. et al. Guidelines for good validation practice (FIP). *Pharm Ind* 42: 982 (1980); also *Drugs Made in Germany*, 26:80–85 (1983).
5. EOQC, Section for Pharm. and Cosmetic Ind. 4th European Seminar: *Validation of Manufacturing Processes*, Geneva (1980).
6. Sucker, H., ed. *Praxis der Validierung*. Stuttgart: Wissenschaftliche Verlagsgesellschaft GmbH (1983).
7. *Guide to Good Manufacturing Practice of Medicinal Products*. PH 1/97 (Rev. 2). Geneva: PIC/S Secretariat (2001).

8. *Theory and Concepts in Validation*. Dublin: PIC-Seminar (1982).
9. U.S. Food and Drug Administration. *Guide to Inspections: Validation of Cleaning Processes*. Rockville, MD: Division of Manufacturing and Product Quality, Office of Compliance (1993).
10. *The Gold Sheet* 32(2), (Feb. 1998).
11. U.S. Food and Drug Administration. *CGMP: Proposed Amendment of Certain Requirements for Finished Pharmaceuticals*, 21 CFR Parts 210 and 211, Rockville, MD (1996).
12. European Commission. *The Rules Governing the Medical Products in the European Union, Volume 4, Good Manufacturing Practices*. Brussels: Directorate General III—Industry, Pharmaceuticals and Cosmetics (1998).
13. *Therapeutic Goods Agency*. Woden/Canberra (2001); <http://www.health.gov.au/tga>.
14. World Health Organization. *WHO Guidelines on the Good Manufacturing Practices for Pharmaceutical Products*. Technical Report Series. no. 823, thirty-second report, Geneva (1992).
15. Marrer, S. *Pharm Ind* 55: 808–820 (1993).
16. Health Canada. *Good Manufacturing Practices Guidelines*. 2002 ed. Health Products and Food Branch Inspectorate (Dec. 2001).
17. Ministry of Health and Welfare (MHW). *Regulations for Manufacturing and Quality Control of Drugs*. MHW ordinance no. 3. Japan (1994).
18. World Health Organization. *Guidelines on the Validation of Manufacturing Processes*. Annex 5 to *Good Manufacturing Practices for Pharmaceutical Products* (Ref. 14). Geneva (1993).
19. Ministry of Health, Labor, and Welfare. *Validation Standards*. PAB notification no. 158. Tokyo (March 1, 1995).  
Ministry of Health, Labor, and Welfare. *Validation Standards*. PAB notification no. 660. Tokyo (June 30, 2000).
20. Health Canada. *Validation Guidelines for Pharmaceutical Dosage Forms*. Ottawa: Therapeutics Products Programme (2000); [www.hc-sc.gc.ca/hpb-dgps/therapeut](http://www.hc-sc.gc.ca/hpb-dgps/therapeut).
21. *Recommendations on Validation Master Plan, Installation and Operational Qualification, Non-Sterile Process Validation and Cleaning Validation*. Geneva: PIC/S 1/99-2, PIC/S secretariat (1999).
22. European Commission. *Qualification and Validation*. Annex 15 to the EU guide to GMP. Brussels (2001).
23. *Good Manufacturing Practice Guide for Active Pharmaceutical Ingredients*. ICH Harmonized Tripartite Guideline, step 4 (Nov. 10, 2000); issued as CPMP/ICH/1935/00 (EU; Nov. 2000); PMSB notification 1200 (J; Nov. 2001); CFR vol. 66, no. 186, 49028–49029 (U.S.; Sept. 2001).
24. International Pharmaceutical Excipients Council. *Good Manufacturing Practices for Bulk Pharmaceutical Excipients*: [www.ipec.org](http://www.ipec.org) (rev. 2001).
25. *Good Manufacturing Practices for Bulk Pharmaceutical Excipients*. United States Pharmacopeia 24, General Chapter <1078>, 2040–2049 (2000).
26. International Pharmaceutical Excipients Council. *Good Manufacturing Practices Audit Guideline for Bulk Pharmaceutical Excipients*. (1997).
27. Nash, R. A. Validation of pharmaceuticals processes. In: J. Swarbrick, J. C. Boylan,

- eds. *Encyclopedia of Pharmaceutical Technology*. vol. 16. New York: Marcel Dekker, p. 206 (1997).
28. Auterhoff, G. *Pharm Ind* 53: 798–803 (1991).
  29. Walter, E. *Pharm Ind* 56: 425–437 (1994).
  30. U.S. Food and Drug Administration. Medical devices current good manufacturing practice (CGMP). *Fed Reg* Part 820, Quality System Regulation. Rockville, MD (1996).
  31. SCRIP Daily (Nov. 12, 2001).
  32. Schicht, H. H. *International Standards on Cleanroom Technology and Their Impact on the Pharmaceutical Industry—An Update*. Parenteral Drug Association, Basel Congress (2002).
  33. Audit Repository Center (ARC), Pottstown, PA; [www.auditcenter.com](http://www.auditcenter.com).
  34. PDA Letter, 27 (Nov. 2000).
  35. International Society for Pharmaceutical Engineering. *GAMP Guide for Validation of Automated Systems*. 4th ed. Brussels: European Office (2001).
  36. European Economic Community. *Council Directive 75/319/EEC* (1975).
  37. European Economic Community. *Council Directive 91/356/EEC* (1991).
  38. European Economic Community. *Notice to Applicants*. Medicinal Products for Human Use, vol. 2B (1998).
  39. EudraLex. *Quality Guideline 3AQIA Development Pharmaceuticals and Process Validation*. Medicinal Products for Human Use: Guidelines, vol. 3 (1988).
  40. European Agency for the Evaluation of Medicinal Products. *Note for Guidance on Process Validation*. Committee for Proprietary Medicinal Products, CPMP/QWP/848/96, London (2001).
  41. Hoff, S. F. *Drug Info J*, 34: 659–676 (2000).